



Text-Book Series in Education

EDITED BY PAUL MONROE, PH.D.

PRINCIPLES
OF
SECONDARY EDUCATION

TEXT-BOOK SERIES IN EDUCATION

THE HISTORY OF EDUCATION

By PAUL MONROE, Ph.D., Teachers College, Columbia University.

THE PRINCIPLES OF EDUCATION

By ERNEST N. HENDERSON, Ph.D., Adelphi College.

STATE AND COUNTY EDUCATIONAL REORGANIZATION

By ELLWOOD P. CUBBERLEY, Ph.D., Leland Stanford Junior University.

PRINCIPLES OF SECONDARY EDUCATION

By a number of Specialists.

TO BE ISSUED

PRINCIPLES OF STATE AND COUNTY SCHOOL ADMINISTRATION

By ELLWOOD P. CUBBERLEY, Ph.D., Leland Stanford Junior University, and EDWARD C. ELLIOTT, Ph.D., University of Wisconsin.

PRINCIPLES OF CITY SCHOOL ADMINISTRATION

By ELLWOOD P. CUBBERLEY, Ph.D., and EDWARD C. ELLIOTT, Ph.D.

HISTORY OF EDUCATION IN THE UNITED STATES

By PAUL MONROE, Ph.D.

SOURCE BOOK SERIES IN EDUCATION

A SOURCE BOOK IN THE HISTORY OF EDUCATION FOR THE GREEK AND ROMAN PERIODS

By PAUL MONROE, Ph.D., Teachers College, Columbia University.

TO BE ISSUED

A SOURCE BOOK IN STATE AND COUNTY SCHOOL ADMINISTRATION

By ELLWOOD P. CUBBERLEY, Ph.D., and EDWARD C. ELLIOTT, Ph.D.

A SOURCE BOOK IN CITY SCHOOL ADMINISTRATION

By ELLWOOD P. CUBBERLEY, Ph.D., and EDWARD C. ELLIOTT, Ph.D.

A SOURCE BOOK IN THE HISTORY OF EDUCATION IN THE UNITED STATES

By PAUL MONROE, Ph.D.

duca
M

PRINCIPLES OF SECONDARY EDUCATION

Written by a Number of Specialists

EDITED BY

PAUL MONROE, PH.D.

PROFESSOR OF THE HISTORY OF EDUCATION, TEACHERS COLLEGE
COLUMBIA UNIVERSITY

135-714
3/2/15-

New York
THE MACMILLAN COMPANY
1914

All rights reserved

COPYRIGHT, 1914,
BY THE MACMILLAN COMPANY.

Set up and electrotyped. Published October, 1914.

Norwood Press
J. S. Cushing Co. — Berwick & Smith Co.
Norwood, Mass., U.S.A.

PREFACE

THE scope of secondary education is now so broad, its purpose and aim are so diversified, that no one specialist can aspire to be accepted as an authority in the entire field. The content of secondary education is so diverse, methods of instruction and of administration are so varied, that no one practitioner can hope to present views acceptable to all engaged in the field. When unity of views or of practice does not exist, it is impossible to express a unified philosophy or to formulate a procedure universally valid. Under such circumstances, it seems best to prepare the prospective teacher or administrator for his work by giving him the conclusions representing the best thought and practice in this entire field. Especially is this procedure advantageous if, as in the case of this volume, the specialists writing have a broad acquaintance with present practices, intelligent views and wide sympathies in the whole field of education, and also a tolerance of innovation justified by experience.

The insight which results from the consideration of views of many specialists, thus animated by a common purpose and possessing a wide experience in our secondary schools, is superior to the unity which may come from the views of one man no matter what his qualifications. Moreover, the principles thus derived will be much more representative of actual conditions, and hence will offer a more adequate preparation for the novice.

Several of the chapters of this volume are taken wholly or in part from the *Cyclopedia of Education*. The remaining chapters are prepared for this volume alone. The author of any chapter has no responsibility for the views expressed in

any other ; nor is the editor necessarily in sympathy with the views expressed. At various points there may be conflict between the views advanced by the various writers. The unity of the volume is to be found in a common purpose, a sympathetic and tolerant attitude, and the experience upon which the views of each specialist are based.

The purpose of this volume is to furnish the student a body of fact and opinion that through study and discussion he may acquire some knowledge of the entire field of secondary education, its purposes and its problems.

THE EDITOR.

CONTRIBUTORS

CHAPTER I. MEANING AND SCOPE OF SECONDARY EDUCATION.
The Editor.

CHAPTER II. HISTORIC SKETCH OF SECONDARY EDUCATION.
The Editor.

CHAPTER III. EUROPEAN SYSTEMS OF SECONDARY SCHOOLS.
Frederic E. Farrington, Ph.D., Associate Professor of Education, Teachers College, Columbia University.

CHAPTER IV. THE HIGH SCHOOL SYSTEMS OF THE UNITED STATES.

State Systems of High Schools:

Ellwood P. Cubberley, Ph.D., Professor of Educational Administration, Leland Stanford Junior University, Stanford University, Cal.

Rural High Schools:

Edwin R. Snyder, Ph.D., State Normal School, San Jose, Cal.

Maintenance and Support:

Ellwood P. Cubberley, Ph.D.

Inspection and Accrediting of School:

W. Scott Thomas, University of California, Berkeley, Cal.

CHAPTER V. ORGANIZATION OF THE HIGH SCHOOL.

High School Administration:

W. D. Lewis, Principal, William Penn High School for Girls, Philadelphia, Pa.

The Curriculum :

David Snedden, Ph.D., Commissioner of Education, State of Massachusetts.

The Elective System :

David Snedden, Ph.D.

The Six-Year Course of Study :

David Snedden, Ph.D.

CHAPTER VI. THE PRIVATE SECONDARY SCHOOL.

James G. Crosswell, Head Master, The Brearley School, New York City.

CHAPTER VII. PSYCHOLOGY AND HYGIENE OF ADOLESCENCE.

Guy Montrose Whipple, Ph.D., Assistant Professor of Educational Psychology, Cornell University, Ithaca, N. Y.

CHAPTER VIII. MORAL EDUCATION IN THE HIGH SCHOOL.

Edward O. Sisson, Ph.D., Commissioner of Education, Boise, Idaho.

CHAPTER IX. THE VERNACULAR.

English Literature :

Franklin T. Baker, Ph.D., Professor of English Language and Literature, Teachers College, Columbia University.

George P. Krapp, Ph.D., Professor of English, Columbia University.

Composition :

Franklin T. Baker, Ph.D.

Oral Speech :

Erastus Palmer, A.M., Professor of Public Speaking, College of the City of New York.

CHAPTER X. THE CLASSICAL LANGUAGES AND LITERATURES.

Latin :

Gonzalez Lodge, Ph.D., Professor of Latin and Greek, Teachers College, Columbia University.

Greek :

Thomas D. Goodell, Ph.D., Professor of Greek, Yale University, New Haven, Conn.

CHAPTER XI. MODERN LANGUAGES.

Elijah William Bagster-Collins, A.M., Associate Professor of German, Teachers College, Columbia University.

CHAPTER XII. THE NATURAL SCIENCES.

George R. Twiss, B.Sc., State High School Inspector, and Professor of the Principles and Practice of Secondary Education, Ohio State University.

CHAPTER XIII. MATHEMATICS.

David Eugene Smith, Ph.D., Professor of Mathematics, Teachers College, Columbia University.

CHAPTER XIV. THE SOCIAL SCIENCES.

History :

Henry E. Bourne, Ph.D., Professor of History, Western Reserve University.

Civics :

James Sullivan, Ph.D., Principal of Boys' High School, Brooklyn, N. Y.

Economics :

Edwin R. A. Seligman, Ph.D., Professor of Political Economy, Columbia University.

CHAPTER XV. THE FINE ARTS AND MUSIC.

Art in Education :

John Dewey, Ph.D., Professor of Philosophy, Columbia University.

Methods of Teaching Art; Design :

Arthur Wesley Dow, Professor of Fine Arts, Teachers College, Columbia University.

Music :

Charles H. Farnsworth, Associate Professor of Music, Teachers College, Columbia University.

CHAPTER XVI. THE HOUSEHOLD ARTS.

Ann Gilchrist Strong, Professor of Household Economics,
University of Cincinnati.

CHAPTER XVII. VOCATIONAL EDUCATION.

Industrial Education:

Charles R. Richards, S.B., Director Cooper Union for the
Advancement of Science and Art.

Commercial Education:

Joseph H. Johnson, D.C.S., Dean of School of Commerce,
New York City.

Agricultural Education:

Clarence H. Robison, Ph.D., Professor of Education, Nor-
mal School, Montclair, N. J.

CHAPTER XVIII. HYGIENE AND PHYSICAL EDUCATION.

Thomas A. Storey, M.D., Professor of Physical Education,
College of the City of New York.

George R. Meylan, M.D., Assistant Professor of Physical
Education, Columbia University.

CHAPTER XIX. ATHLETICS.

Clark W. Hetherington, A.B., Professor of Physical Educa-
tion, and Director of Athletics, University of Missouri.

CHAPTER XX. SOCIAL ASPECTS OF HIGH SCHOOL EDUCATION.

Clarence A. Perry, Ph.D., Division of Recreation, Russell
Sage Foundation.

CHAPTER XXI. REORGANIZATION OF SECONDARY EDUCATION.

David Snedden, Ph.D.

CONTENTS

CHAPTER I

INTRODUCTION: MEANING AND SCOPE OF SECONDARY EDUCATION

	PAGE
FUNDAMENTAL IMPORTANCE OF THE SECONDARY SCHOOL	I
NO AGREEMENT AS TO SCOPE OR MEANING OF SECONDARY EDUCATION	I
Reasons for this Diversity	2
SECONDARY EDUCATION DETERMINED BY THE NATURE OF THE PROCESS: TRAINING <i>vs.</i> INSTRUCTION	3
SECONDARY EDUCATION BASED UPON SUBJECT MATTER DISTINCTION BASED UPON PROFESSIONAL PREPARATION	4
SECONDARY EDUCATION AS A CLASS DISTINCTION	5
SECONDARY EDUCATION AS A MEANS OF SOCIAL SELECTION	6
SECONDARY EDUCATION BASED ON PHYSIOLOGICAL AND PSYCHOLOGICAL AGE	7
SECONDARY EDUCATION DETERMINED BY THE STUDENT'S INTERESTS AND ABILITIES	9
THE PRESENT IS A COMBINATION OF ALL THESE FACTORS	10
SECONDARY EDUCATION AS A PREPARATION FOR SOCIAL SERVICE AND A TRAINING IN EFFICIENCY	11
SECONDARY EDUCATION AS A PREPARATION FOR SOCIAL SERVICE AND A TRAINING IN EFFICIENCY	14

CHAPTER II

HISTORIC SKETCH OF SECONDARY EDUCATION

ORIGIN OF THE DISTINCTION BETWEEN ELEMENTARY AND SECONDARY EDUCATION	16
Origin of the Practical Distinction	16
Origin of the Theoretical Distinction	19

	PAGE
THE SECONDARY SCHOOLS OF GREECE	22
The Philosophical Schools	22
The Rhetorical Schools	22
THE ROMAN SECONDARY SCHOOL	24
The Grammar School	25
The Curriculum	25
The Roman Contribution to Method	27
THE MIDDLE AGES AND THE SECONDARY SCHOOL	29
Types and Extent of these Schools	30
Free Schools and Endowments	31
The Curriculum	33
Method	34
THE SECONDARY SCHOOL IN THE RENAISSANCE-REFORMATION PERIOD. THE LATIN GRAMMAR SCHOOL	36
The Establishment of Schools	37
Number and Type of Schools	38
Curriculum of the Latin Grammar Schools	40
Method of the Grammar Schools	42
THE VARIANT TYPE. THE REALISTIC SCHOOL	44
Organization of the New Type of Education	45
<i>The English Academies</i>	46
<i>The German Realschulen</i>	47
Influence on the Curriculum	49
Influence on Method	50
THE LATIN GRAMMAR SCHOOL IN AMERICA	51
Curriculum	53
THE ACADEMY IN AMERICA	54
Curriculum and Method	57
THE AMERICAN HIGH SCHOOL	60
Origin	61
Development of the High School System	64

CHAPTER III

SECONDARY EDUCATION IN EUROPE

FRANCE

POSITION OF SECONDARY EDUCATION ABROAD	71
DEVELOPMENT OF THE SYSTEM OF SECONDARY SCHOOLS	72
THE SYSTEM	74
Centralization of Control	74
Secondary Education is nowhere compulsory in France	74
Types of Schools	75

	PAGE
Unrest in Secondary Education	75
Primary and Secondary Schools Defined	76
Characteristics of the Course	78
Baccalaureate Degree	85
School Population	87
Boarding Schools	87
Teaching Force	88
Salaries	91
School Fees	93
Budget	93
EDUCATION OF GIRLS	94
Organization	95
Program of Studies	96
School Population	98
Academic Distinctions	99
Standards of Teachers	99
General Characteristics	100

GERMANY

SOCIAL BACKGROUND	101
EDUCATIONAL CONTROL	102
PRIMARY AND SECONDARY SCHOOLS	105
BOYS' HIGHER SCHOOLS	108
Gymnasium	108
Realgymnasium	109
Oberrealschule	110
Number of Schools	111
Fees	112
EARLY SPECIALIZATION DEFERRED	112
Reform Plan Schools	113
EDUCATION OF GIRLS. TYPES OF SCHOOLS	115
Reorganization of Girls' Schools	116
Program of Studies	118
TRAINING OF TEACHERS	120
Salaries	121

ENGLAND

ENGLISH AND CONTINENTAL CONDITIONS CONTRASTED	122
"PUBLIC" SCHOOLS AND PUBLIC LIFE	123
Classical Influence	125
Organization	126
Programs of Studies	127

	PAGE
Training for Leadership	128
School Life	129
Characteristics of the Public Schools	130
PREPARATORY SCHOOLS	130
OTHER TYPES OF SECONDARY SCHOOLS	131
EFFECTS OF THE EDUCATION ACT OF 1899	132
SECONDARY SCHOOL DEFINED	134
REGULATIONS OF THE BOARD OF EDUCATION	135
OPPORTUNITIES FOR FREE EDUCATION	136
Present Conditions	137
PROGRAM OF STUDIES	138
COMPARATIVE FIGURES FOR SECONDARY SCHOOL POPU- LATION	140

CHAPTER IV

THE HIGH SCHOOL SYSTEMS OF THE UNITED STATES

STATE SYSTEMS	146
Legal Provisions	146
The General Type	146
Organization of Control	148
Rural High Schools	149
<i>Curriculum</i>	150
<i>Statistical Summary</i>	151
MAINTENANCE AND SUPPORT	154
Stages in Development	155
Types of Highest Development	158
Basis of Apportionment	160
INSPECTION AND ACCREDITING OF SCHOOLS	161

CHAPTER V

THE ORGANIZATION OF THE HIGH SCHOOL

THE ADMINISTRATION OF THE HIGH SCHOOL DETER- MINES ITS EFFICIENCY	174
The Principal is the Chief Factor in the Administration	174
Full Support of the Faculty Necessary for the Best Results	175
THE PROBLEM OF ADMINISTRATION	175
The Course of Study	175
THE DAILY ROSTER FOR PROMOTION BY SUBJECT	177
Data Necessary as a Working Basis	178
Non-conflicting Term Units are Necessary	180

	PAGE
Regular and Irregular Students	180
Double Periods	180
Advantages of a Regular Roster Maker	182
ASSIGNMENT OF WORK TO TEACHERS	182
The Number of Periods required a Week from each Teacher	183
Special Duties	184
THE PRINCIPAL'S RELATION TO THE VARIOUS ACTIVITIES OF THE SCHOOL	184
RELATION BETWEEN THE GRAMMAR SCHOOL AND THE HIGH SCHOOL	186
Coöperation between the High School Principal and the Grammar School Principal	186
Visits and Reports between the Schools	187
RELATION BETWEEN THE HIGH SCHOOLS AND THE COLLEGES	188
DISCIPLINE	188
Successful Discipline depends on Understanding the Adolescent	188
Public Sentiment of the School the most Important Factor	189
Gradual Introduction of Student Participation in School Government	189
Social and Political Reasons for Student Participation in School Government	191
HUMANIZING THE SCHOOL	193
Student Advisor System	193
ADAPTING THE SCHOOL TO COMMUNITY NEEDS	194
The Changed Problem	194
Study of Conditions Essential as a Basis for Change in Procedure	195
The Community Element	195
The Coöperation of Industry Necessary to the Fullest Service of the Secondary School	199
This Broader Service demands Open-mindedness of the Principal	200
THE PRINCIPAL AND THE TEACHER	201
Who shall Pass ?	202
Limitation of the Teacher whose Chief Interest is in his Subject	202
The Purpose of Teaching a Given Subject should determine Content and Method	203
An Illustration from History	204
The Principal must visit Classes	206
The Teachers' Meeting. It should be Democratic	207

	PAGE
SCIENTIFIC MEASUREMENT ESSENTIAL	208
Graph showing an Uneven Department	209
Typical Statement of Pupil-hours per Teacher	210
THE PRINCIPAL AND THE BOARD OF EDUCATION	211
HOW THE DIRECTION OF OUR HIGH SCHOOLS CAN BE MADE MORE ATTRACTIVE TO FIRST-CLASS MEN	213
THE CURRICULUM	214
Types of High School Curricula	216
THE ELECTIVE SYSTEM OF SECONDARY SCHOOLS	220
SIX-YEAR COURSE OF STUDY	226

CHAPTER VI

THE PRIVATE SECONDARY SCHOOL

CHARACTERISTICS OF PRIVATE SCHOOLS	233
VALUE OF PRIVATE SCHOOLS	235
PRIVATE SECONDARY SCHOOLS	235
Vocational Schools	237
Preparatory Schools	239
Military Schools	240
Denominational Schools	241
SOCIAL SELECTION	241

CHAPTER VII

PSYCHOLOGY AND HYGIENE OF ADOLESCENCE

PHYSIOLOGICAL SIGNIFICANCE OF THE ADOLESCENT PERIOD	246
Variability is Itself Characteristic of the Period	248
Physiological Age	248
<i>The Concept of Retardation and Acceleration</i>	248
<i>Relation of Physiological Age to Success in High School</i>	249
Growth in Height and Weight	250
Growth and Health	252
Growth by Parts	252
Growth of the Bones	253
<i>Hygiene of Bone Growth</i>	253
Growth of the Muscles	254
Growth of Heart and Arteries	254
<i>Circulatory Disturbances</i>	255
Growth of the Lungs	255
<i>Training for Vital Capacity</i>	255

	PAGE
Changes in the Voice	256
<i>Period of Mutation</i>	256
<i>Hygiene and Training of the Voice</i>	256
Growth of the Brain	257
THE PSYCHOLOGICAL PHENOMENA OF ADOLESCENCE	257
Primary and Secondary Sex Characters	258
Ramifications of the Sex Instinct in Mental Life	259
Sensory Development	259
<i>New Dermal Consciousness</i>	260
<i>New Smell and Taste Interests</i>	261
<i>New Aural Interests</i>	261
The Sex Instinct	262
<i>Sex Charms and Fetishes</i>	263
<i>The Development of Love</i>	264
<i>Instruction in Sex Hygiene</i>	266
The Migratory Instinct	270
THE SOCIAL ASPECTS OF ADOLESCENCE	272
The Social Instincts	272
<i>Gregariousness</i>	273
<i>Sympathy</i>	273
<i>Approbation</i>	274
<i>Altruism</i>	275
Self-organized Groups	275
Maxims for organizing Societies	276
Variety of Adult-made Societies	277
School Organizations	278
High School Secret Societies	279
<i>Alleged Merits</i>	279
<i>Alleged Faults</i>	280
<i>Solutions of the Fraternity Problem</i>	281
Self-government Plans	282
<i>The "School City"</i>	282
<i>Simpler Self-government Plans</i>	283
Group Work in the Classroom	284
RELIGIOUS AND MORAL ASPECTS OF ADOLESCENCE	285
Religious Conversion in Adolescence	285
<i>The Explanation</i>	286
<i>Tendencies toward Conventionalizing Conversion</i>	286
Periods of Intellectual Reconstruction	287
Studies of Ideals	289
<i>Ideals depend on Age</i>	289
<i>Ideals depend on Sex</i>	290
<i>Ideals depend on Home Life and Social Station</i>	290

	PAGE
<i>Ideals depend on Type of School Instruction</i>	290
<i>The Variety of Occupational Ideals</i>	291
<i>Their Alterations</i>	291
<i>Ovcrambitious Ideals</i>	291
MENTAL PATHOLOGY OF ADOLESCENCE	292
Developmental Retardation	292
<i>Higher Retardations as a School Problem</i>	294
Adolescent Criminality	294
<i>Causes</i>	294
<i>Remedies</i>	296
INTELLECTUAL GROWTH IN ADOLESCENCE	297
The Problem of Formal Discipline	298
<i>The Older View</i>	300
<i>Arguments against It</i>	301
<i>Experimental Studies of Transfer</i>	302
<i>Conclusions based upon Adults may not apply to Children</i>	304
<i>Negative Transfer</i>	304
<i>The Teacher as a Factor</i>	305
Alleged Inadequacies of High School Science	306
Linguistic Interests	307
Literary Interests	307
Art Interests	308
COEDUCATION	308

CHAPTER VIII

MORAL AND RELIGIOUS EDUCATION

HOW THE WILL GROWS	313
Will Development through Will Action	313
Intellectual Aspect	315
The Moral Element pervades All	316
The Will Exercises on Problems	317
The Sources of Energy	318
The Broadening of Sympathy	319
THE PROBLEMS OF YOUTH	320
What are the Problems?	320
Sources of Information	321
The Larger Life	323
The Point of Contact	325
The Great Problems	325
THE GREAT DETERMINATIONS	327
The Realization of the Self	327
<i>Physique</i>	327

	PAGE
<i>Intellectual Initiative</i>	329
<i>Personal Ideals</i>	330
Vocation	331
<i>Effect upon the Curriculum</i>	333
<i>Vocational Guidance</i>	333
The Zest of Life	334
Mutual Relations of the Sexes	336
<i>Honor and Ideals</i>	336
<i>A Gap in the Curriculum</i>	337
WAYS AND MEANS	338
School Life	338
School Government	339
School Work	341
Studies	342
<i>Moral Values</i>	343
<i>The Classics</i>	343
<i>Heroes</i>	344
<i>The New Order</i>	345
<i>Moral Idealism</i>	346
RELIGION	347
The Secular School	347
Reaction	348
The Letter and the Spirit	349
Means	350
THE HIGH SCHOOL TEACHER	350
Limitation by Conditions	350
Remedies	351

CHAPTER IX

THE VERNACULAR

THE TEACHING OF LITERATURE	356
ENGLISH LITERATURE IN SECONDARY SCHOOLS	357
Literary Appreciation	358
Study of the Vocabulary	358
The Literary Language	359
The Philological Method	360
Technique and Structure	361
Moral and Cultural Value	362
Grading the Material	363
THE TEACHER AS AN INTERPRETER OF LITERATURE	363
COMPOSITION	373
The Teaching of Composition	374

	PAGE
TRAINING IN ORAL SPEECH	379
COLLEGE ENTRANCE REQUIREMENTS IN ENGLISH	382

CHAPTER X

THE CLASSICAL LANGUAGES AND LITERATURES

LATIN

PLACE IN THE CURRICULUM	387
THE VALUE OF LATIN	387
METHODS OF TEACHING	389
Difficulties of the Student	390
The Introductory Work; the Customary Method	391
The Oral or Direct Method	395
Pronunciation	396
The Later Reading	398
<i>Transition to Caesar</i>	398
<i>Cicero</i>	401
<i>Ovid</i>	403
<i>Vergil</i>	403
<i>Other Selections</i>	405

GREEK

PURPOSE AND VALUE	406
The Approach to the Hellenic Spirit	407
METHOD FOR BEGINNERS	408
Pronunciation	409
Oral Methods	410
Reading	411
Minor Principles of Method	413
PLACE IN SCHOOLS	415

VISUAL AIDS

LATIN AND GREEK	420
---------------------------	-----

CHAPTER XI

MODERN LANGUAGES

PURPOSE OF STUDY OF MODERN LANGUAGE	424
METHOD	424
Pronunciation	424
Oral Practice	425
Grammar	427
Written Work	428
Reading	429

	PAGE
RESULTS OF SCHOOL WORK	431
PLACE OF MODERN LANGUAGES IN THE CURRICULUM	431
United States	432
<i>In Colleges</i>	432
<i>College Entrance Requirements</i>	433
<i>Reports on the Curriculum Requirements and Methods</i>	433
<i>Distribution of Pupils</i>	435
Germany	436
<i>Method</i>	437
France	439
England	442

CHAPTER XII

THE NATURAL SCIENCES

EDUCATIONAL FUNCTIONS AND VALUES OF THE SCIENCES

WHAT SCIENTIFIC STUDY SHOULD DO FOR THE PUPILS	446
Specific Habits	448
<i>The Law of Habit Formation</i>	449
<i>Application of the Law of Association in Teaching</i>	450
Scientific Information	450
<i>The Choice of Subject Matter</i>	450
<i>Criteria for the Choice of Subject Matter</i>	451
<i>The Mastery of Content</i>	452
Inspiration and Scientific Ideals	453
Mental Discipline	454
<i>Applying the Principles of Transfer</i>	455
<i>How Concepts of Method are built up</i>	456
<i>Precepts for the Conduct of Transferable Training</i>	457
Developing Powers of Interpretation	458

THE TECHNIQUE OF INSTRUCTION IN THE SCIENCES

CURRENT METHODS	459
The Problem as the Center of Unification	459
THE CLASS CONFERENCE	460
THE FUNCTION OF THE LABORATORY	462
Number of Laboratory Exercises per Year	464
Size of Laboratory Divisions	464
Double Periods	465
Form of Notes	465
Inspection of Notes by the Teacher	466

	PAGE
LECTURE DEMONSTRATIONS	467
FIELD OBSERVATION	467
REVIEWS	470
The Topical Recitation	471
Written Reviews	472
<i>THE SCIENCES AND THE CURRICULUM</i>	
COLLEGE ENTRANCE REQUIREMENTS	473
THE SCIENCE SUBJECTS	475
<i>GEOGRAPHY</i>	
GEOGRAPHIC CONTROLS	476
BEGIN WITH LOCAL PROBLEMS	477
TEXTBOOKS	479
REPORTS OF NATIONAL COMMITTEES, BOOKS, AND MAGAZINE ARTICLES	480
PHYSIOGRAPHIC PROCESSES	482
The Geographic Cycle	482
Physiographic Controls	483
PRINCIPLES OF SELECTION AND ORDER	483
FIELD WORK, LABORATORY WORK, AND EQUIPMENT	484
ORDER OF TOPICS	485
<i>BIOLOGY</i>	
BIOLOGICAL PROBLEMS	486
POINTS OF VIEW FROM BIOLOGICAL STUDY	486
PRINCIPLES TO BE OBSERVED IN A BIOLOGICAL COURSE	488
GENERAL METHOD IN BIOLOGICAL STUDY	493
SPECIAL METHODS	493
CORRELATION OF BOTANY, ZOOLOGY, AND PHYSIOLOGY	494
<i>PHYSICS</i>	
COMMON-SENSE NOTIONS AND PHYSICAL PRINCIPLES	495
Intuitions and the Facts of Everyday Life as Starting Points	496
Some Intuitive Notions Described	498
The Question of Tyndall's Boys	500
ECONOMY OF TIME AND EFFORT	503
FUNDAMENTAL CONCEPTS	504
SYLLABI	505
LABORATORY WORK	505
THE PROGRESSIVE PROGRAM	506
<i>CHEMISTRY</i>	
THE PSYCHOLOGICAL BASIS	508
HOW TO BEGIN	509

	PAGE
HOW TO USE THE TEXTBOOK	512
THE CONTENT OF CHEMISTRY	513
Chemical Laws	515
Type Reactions	516
Practical Applications	517

THE TEACHER

PERSONALITY	519
TRAINING	519
PROFESSIONAL SPIRIT	521

CHAPTER XIII

MATHEMATICS

NATURE AND USE OF THE SUBJECT	529
Reasons for its Study	530
Branches of the Subject	530
Range of Secondary Mathematics	531
ALGEBRA	531
General Nature of the Subject	531
Reasons for Studying Algebra	532
Present Status in the Curriculum	534
In European Schools	536
GEOMETRY	536
Reasons for Studying Geometry	537
Present Status of the Teaching of Geometry	538
Reforms and Improvements	539
ALGEBRA AND GEOMETRY IN THE GRAMMAR GRADES	541
College Entrance Requirements in Mathematics	544
SPECIAL VISUAL AIDS TO TEACHING MATHEMATICS	546

CHAPTER XIV

THE SOCIAL SCIENCES

HISTORY

NATURE OF HISTORY	549
MATERIALS OF HISTORY	550
PROBLEMS OF TEACHING HISTORY	551
THE CHOICE OF MATERIALS. ORGANIZATION OF THE COURSE OF STUDY	552
Growth of History in College and School Curricula	553
Report of the Committee of Ten	554

	PAGE
The Committee of Seven	555
Recent Modifications	557
Modification of Course in New Types of Schools	558
European Courses of Study and Programs	558
METHODS OF TEACHING	560
VISUAL AIDS TO TEACHING HISTORY	564
CIVICS	
THE TERM CIVICS	565
INTRODUCTION INTO THE SCHOOLS	565
PRESENT STATUS	567
METHODS OF TEACHING CIVICS	569
ECONOMICS	
ECONOMICS IN THE SCHOOLS	573
CHAPTER XV	
FINE ARTS AND MUSIC	
ART IN EDUCATION	578
Classification of the Arts	578
Principles underlying Art in Education	579
<i>Arts are Essentials in Education</i>	580
<i>Expression precedes Appreciation</i>	580
<i>Social Activities furnish the Starting Point</i>	581
<i>Artistic Expression natural to Children</i>	581
<i>Literature the most General Art for School Purposes</i>	582
METHODS OF TEACHING ART	582
The Two Methods	583
<i>The Academic Method</i>	583
<i>The Structural Method</i>	585
The Two Methods in the Schools	587
DESIGN AS THE SUBJECT RELATING FINE ARTS TO	
PRACTICAL ARTS	587
Industrial Design	588
Design in the Fine Arts	589
Relation of Design to the Arts of Representation	591
Place of Design in Education	592
<i>Present School Conditions</i>	592
MUSIC TEACHING IN THE SCHOOLS	594
Recent Tendencies towards a Broader Use and Appreciation of	
Music in the School	595
<i>Instrumental Music</i>	595
<i>Singing</i>	596

	PAGE
Methods in School Music	597
<i>Interpretation</i>	598
<i>Structure</i>	599
<i>Key</i>	600
<i>Interval</i>	601
<i>Rhythm</i>	602
<i>Present Procedure</i>	602
New Tendencies	603

CHAPTER XVI

HOUSEHOLD ARTS

PRACTICAL ARTS IN EARLY EDUCATION	608
BROAD CONTENT OF HOUSEHOLD ARTS	609
The Purpose of the Household Arts	610
SCHOOL WORK SHOULD CONNECT CLOSELY WITH LIFE	611
CLOTHING AND HYGIENE	612
FOOD AND NUTRITION	613
Technical Skill to be Gained	614
Scientific Knowledge	615
Waste	615
HOUSING CONDITIONS, HOUSE PLANNING, AND HOME	
KEEPING	616
Moral and Economic Values of Such Instruction	617
EQUIPMENT	618
Elimination of the Artificial	619
Value and Results of Training in Housekeeping	619
EXHIBITIONS	620
TEACHERS	621
THE HOME IDEA MUST BE PRESERVED	623
VOCATIONAL ASPECT OF HOUSEHOLD ARTS	624
The Trade School	624
The Girls' Technical High School	626
The Household Arts in the Academic High School	629
HOUSEHOLD ARTS IN SCHOOLS OF THE UNITED STATES	632
Massachusetts	632
New York	633
Ohio	634
Iowa	635
Indiana	636
Wisconsin	636
Federal Subsidies	637

CHAPTER XVII	
VOCATIONAL EDUCATION	
SCOPE OF VOCATIONAL EDUCATION	PAGE 641
<i>INDUSTRIAL EDUCATION</i>	
INDUSTRIAL EDUCATION	642
General Definition	642
Origin of the Present Problem	643
Factors in the Problem	644
European Experience	645
United States	646
<i>Evening Schools</i>	647
<i>Technical Schools</i>	648
<i>Manual Training</i>	648
<i>Trade Schools</i>	649
<i>Preparatory Trade Schools</i>	651
<i>Part-time and Coöperative Plan</i>	652
<i>Apprenticeship and Corporation Schools</i>	654
<i>Secondary Technical Schools</i>	655
<i>Technical High Schools</i>	655
Legislation in the United States	656
MANUAL TRAINING	658
Educational Value. Underlying Theory	658
Content of Course	660
Place of Manual Training in the Various National Systems	660
Industrial Education and Manual Training	662
<i>COMMERCIAL EDUCATION</i>	
ORIGIN AND NEED OF COMMERCIAL EDUCATION	663
Commercial Education in the Public High School	664
<i>AGRICULTURAL EDUCATION</i>	
DEVELOPMENT OF THE INTEREST IN AGRICULTURAL EDUCATION	671
AGRICULTURAL INSTRUCTION IN THE SCHOOLS	672
Agricultural High Schools	673
THE PRESENT PROBLEM	678
CHAPTER XVIII	
HYGIENE AND PHYSICAL EDUCATION	
HYGIENE	685
PERSONAL HYGIENE	685
The Scope of Personal Hygiene	687

	PAGE
TEACHING OF HYGIENE	688
Instruction in Hygiene in the Schools	689
Scope of a Course in Hygiene	690
Methods of Instruction in Hygiene	692
The Teaching of Hygiene in the High School	692
Legal Requirements	694
SCHOOL HYGIENE	694
Hygiene of the School Child	695
Hygiene of Instruction	696
The Construction and Sanitation of the Schoolhouse	696
PHYSICAL EDUCATION	698
Early Conceptions	698
Modern Views	699
Forms of Exercise	700
Gymnastics and Athletics	700
Educative Value	701
In Schools	703
Gymnastics for Girls	704

CHAPTER XIX

ATHLETICS

EDUCATIONAL VALUE OF ATHLETICS	709
CREATIVE FORCES IN ATHLETICS	711
The Contestant's Incentives	711
The Spectator's Incentives	714
EVILS OF ATHLETICS	716
CONTROL OF ATHLETICS	720
ATHLETICS IN SECONDARY SCHOOLS	724
Stages of Development	724
Organized Athletics	725
Rules of Eligibility	725
Safeguards	726
Events	727
Summary of Values	727
Summary of Effects upon the School	727
Athletic Courtesy	728

CHAPTER XX

SOCIAL ASPECTS OF HIGH SCHOOL EDUCATION

THE SOCIAL VIEWPOINT	732
INTERNAL VIEWPOINT	733
SOCIALIZED METHODS	735

	PAGE
SOCIAL ELEMENT IN ORGANIZATION	736
HIGH SCHOOL EXTENSION	738
SUPPLEMENTARY ACTIVITIES DEMANDED BY SOCIETY	739
CONTENT OF INSTRUCTION	734
CHAPTER XXI	
THE REORGANIZATION OF SECONDARY EDUCATION	
THE FORCES PRODUCING THE PRESENT REORGANIZATION IN SOCIETY	745
THE REORGANIZATION ALREADY ACCOMPLISHED IN SECONDARY EDUCATION	746
THE REORGANIZATION TO BE ACCOMPLISHED	746
UNIFORMITY IN EXISTING AIMS AND PRACTICES	747
RECENT SPECIALIZATION IN HIGH SCHOOLS	749
FUNDAMENTAL NEED FOR FURTHER ADVANCE IN THE REORGANIZATION OF AIMS	750
REORGANIZATION IN METHODS OF TEACHING AND OF PROCEDURE	753
EXISTING NEED FOR REORGANIZATION CAN BE UNDERSTOOD ONLY THROUGH A STUDY OF THE EVOLUTION OF EXISTING PRACTICES	755
CHARACTER OF PROSPECTIVE REORGANIZATION	756
AGENCIES OR INSTITUTIONS CONTRIBUTING TO EDUCATION	756
THE SCHOOL AS THE SPECIAL AGENCY OF EDUCATION	758
CLASSIFICATION OF THE AIMS AND PROCESSES OF EDUCATION AS DETERMINING ITS REORGANIZATION	759
Physical Education	760
Vocational Education	761
Social Education	762
Cultural Education	764
<i>Culture Primarily Based on Contemporary Life</i>	<i>766</i>
<i>Personal Culture and Achievement</i>	<i>767</i>
REORGANIZATION OF SECONDARY EDUCATION NECESSITATED BY FOREGOING ANALYSIS	767
In Physical Education	768
In Vocational Education	769
In Social Education	770
In Cultural Education	770
Effect on the Traditional Subjects	772
Administrative Changes Necessitated	773
THE FINAL WORD IS THIS	774

PRINCIPLES
OF
SECONDARY EDUCATION

PRINCIPLES OF SECONDARY EDUCATION

CHAPTER I

INTRODUCTION: SCOPE OF SECONDARY EDUCATION

FUNDAMENTAL IMPORTANCE OF THE SECONDARY SCHOOL. — The secondary school has been the bearer of the dominant educational traditions from the time of the Renaissance to the present. Until very recent times revolutionary ideas and new methods in education have been worked out in the secondary schools. Herbart formulated and tested all his educational ideas in that phase of education which we would call secondary. Froebel early taught in a secondary school and later developed an experimental one; from this experience he formulated his theories of education a dozen years before he established the first kindergarten. Until the middle of the nineteenth century the secondary school was the dominant educational institution in most countries, more influential in contributing ideas and shaping policies than schools either preliminary or subsequent to it. Even now in most countries except the United States the secondary school is the most important and influential portion of the educational system.

The secondary school has been established longer, in its procedure, organization, curriculum, and method, than either elementary school or university. It has been the most stable as well as most enduring part of our educational system.

NO AGREEMENT AS TO SCOPE OR MEANING OF SECONDARY EDUCATION. — Notwithstanding these facts there is now no consensus of opinion as to the scope or meaning

of secondary education. It has a local significance and a peculiar purpose in each country. In our own country the views concerning secondary education as to its purpose, scope, curriculum, method, or organization are of the most diverse character, even among those who are specialists in this very field.

Reasons for this Diversity.—The reasons for this unsettled condition lie in the nature of the case. Secondary education has meant different things in different ages and to different peoples because of the divergences in social life and structure. As the socially determining phase of education, it has conformed to the varying needs of each stage of social development and of each type of society. The indefiniteness of present views as to the purpose and the scope is due to the very great complexity of modern society and the greatly multiplied needs of modern life; to the enhanced responsibility of the modern school; to the assumption by the elementary school of the place of fundamental and initial importance in the modern educational scheme; and to the fact that in America secondary education has become a superposed stage, not an alternative phase of education.

By passing in brief review the various conceptions of secondary education as these have been shaped by the varying needs of different periods and peoples, an understanding of the present situation may be reached. For the present is heir not only to the achievements of all the ages but to many of their problems. The social situation which secondary education confronts to-day and which the secondary school attempts to meet is a complex of these conditions of the past; so the meaning and scope of secondary education is a complex of these various conceptions and procedures of the past.

The present state of affairs in secondary education is confusing because the several problems of the various stages of the past are now bound up in one situation. No one condition is determining; no statement of the problem of scope and

purpose in terms of a single factor or force or situation or aim is sufficient. A variety of each of these is involved.

The following chapter will work out in greater detail these typical forms of secondary education.

SECONDARY EDUCATION DETERMINED BY THE NATURE OF THE PROCESS: TRAINING *vs.* INSTRUCTION.—The earliest distinction between primary and secondary stages of education to be worked out was that based upon the nature of the process. When education became a conscious social process, its earliest stages were seen to consist in that training in habit formation which produced the character demanded by the adult generation. These desired social and moral qualities revealed themselves chiefly in types of conduct and had little to do with attitudes of mind. But it was soon seen that a different sort of education was necessary for the dominant class of society, characterized by greater intellectual alertness and a tendency to moral innovations. This inquiring class needed an education which would make clear the foundations of the habits formed, and which would even allow a modification of conduct based upon an investigation and consideration of such fundamental conditions. In other words, this new type of education became intellectual instead of moral; its central process was that of instruction as contrasted with training or habit-formation. Incidentally it became restricted to a superior class, while the education of character-formation remained general in its scope. This was the distinction worked out by the Greeks, by whom it was first attained.

This differentiation being accepted, secondary education was seen to be a superior process, elaborated for, and capable of assimilation only by, a superior class and resulting in a superior social product. In its highest form it also assumed a position of distinct superiority in the educational scheme and, with some further historical elaboration, became the "liberal education" of many subsequent generations.

SECONDARY EDUCATION BASED UPON SUBJECT MATTER. — The differentiation of secondary education on the basis of the method used, involved also the choice of subject matter. In its origin, however, this importance of subject matter seemed to be of derivative, not of initial, value. With the elaboration of processes of instruction, as opposed to processes of training, the reflective consideration of human experience became formulated. These formulations of experience were among the many achievements of the Greeks. Thus grammar was developed as a conscious consideration of human speech as a process of expressing experience; rhetoric as conscious consideration of speech as a form of social control; logic as a conscious consideration of human thought as an instrument for the control of human experiences in connection with the social or the physical or the spiritual environment.

The profound emphasis upon the character of subject matter as the determining factor in secondary education was given in the Renaissance period. This emphasis resulted from the realization that the most valuable account of human experience and activities was to be found in the literature of past ages, expressed in tongues which then had become foreign. Secondary education then came to be a matter of the mastery of these foreign languages and literatures. This condition continued to involve the difference in method. But the delimiting factors of secondary education became much broader than method; for the general view of method now came to be not that of instruction as opposed to training, but the method of studying and teaching foreign languages and literatures — or to be more specific, methods of studying Latin and Greek. In this stage secondary education remained for several centuries. This distinction based on subject matter, or on subject matter and appropriate method combined, remains the most important factor in determining the scope and purpose of secondary education. In more recent periods mathematics and science

either came to share with the classics this place as distinctive subject matter or, with modern languages and literature, replaced them altogether.

While subject matter and method have thus been most influential, at least in determining the scope of secondary education, its purpose with given peoples or in given periods has often been determined by other considerations. And at present the distinction furnished by subject matter and method is conspicuously inadequate, even to determine scope.

DISTINCTION BASED UPON PROFESSIONAL PREPARATION.—The separation of the secondary from the lower stage in education was rendered saner as well as more distinct by the condition which early developed, giving a peculiar professional value to these specially selected methods and subjects of study. Even among the Greeks those who applied themselves to the mastery of grammar, rhetoric, and logic soon formed a profession. This group was made a social class, not simply because its members possessed certain special knowledge, but because they possessed valued powers developed by use of the new methods. Such soon became the ruling classes in society; the rhetorician, the philosopher, or the politician, replaced the soldier and those trained by the old methods as the dominant factors in society.

Among the Romans, and especially during the Middle Ages, secondary education was elaborated as a conscious social process into this preparation for the professions dominant in society. To produce the orator and lawyer became the chief object of the Roman grammar and rhetorical schools. With the medieval church in the ascendancy, the higher clergy came to perform practically all the professional services for society. The Latin grammar school came to be the only avenue for admission to these higher branches of the clergy. While subject matter and method were still characteristics, the predominant feature of secondary education was the fact that it was the sole means of preparation for those activities

which directed social forces and the sole entrance to those professions.

With the development of the university the secondary school ceased to be a direct preparation for the professions and became preparatory to the training for these professions now given by the higher schools. And such it has remained. Continuing this peculiar professional privilege, though not fitting directly for the professions, these schools have become more remote from the immediate needs of society and more abstract in their view of subject matter and method.

SECONDARY EDUCATION AS A CLASS DISTINCTION. — As secondary education changed from a professional training to a preparatory stage to such training, it developed another aspect. In losing its distinct professional cast it made a much broader appeal and became a badge of class distinction. This function of secondary education became prominent in the Renaissance and post-Renaissance period. It remains to-day a powerful factor in determining the character and scope of secondary education. Among certain classes of people rather than at any period of history, the significance of secondary education as a class distinction is characteristic.

As the secondary schools, at least the great Public Schools of England, lost their distinct function of preparing poor boys for the university and thus for the clergy, they became popular as training centers for the sons of the gentry. Intellectual work became a subordinate part of the training; subject matter and method became stereotyped, formal, traditional. It was the social stamp given by the peculiar conditions of a highly artificial life that was prized.

This conception of secondary education was most influential during the seventeenth and eighteenth centuries, though it persisted well into the nineteenth as a view accepted not only socially but also educationally. In furnishing the personal motive it undoubtedly is widely operative to-day, though it is

hardly accepted as a social justification or by any group of professional educators.

During the late seventeenth and the eighteenth century this view affected elementary and higher education as well as secondary. For large sections of people, education of any type was the mark of the leisure class. Hence, as is the case with dress or amusement or employment or any form of distinction of the leisure class, the more remote from practical use it was and the more completely it unfitted the possessor for practical activities, the more highly was it valued. Unfortunately the early development of secondary education for girls was entirely on this basis, and this view has largely persisted. For a time any literary education outside of a professional class was regarded as such a class distinction.

With the entrance of women in any numbers to the secondary field, education as a class adornment lost much of its literary cast, and incorporated a great variety of activities characteristic of the leisure classes of those periods.

In European centers the social status of the family is still quite clearly indicated by the type of secondary school to which the children are sent, and it is frequently true that secondary education of a given type is sought merely for social reasons. While the American high school is so broad and indefinite in its scope that it fails to possess much of this peculiar social significance, yet it is true, partly because of its very lack of definite purpose, that many attend because it is an index of social class.

This factor of class significance is one of the causes for the difficulty of developing in the United States a more strictly vocational type of secondary schools similar to those in European countries.

SECONDARY EDUCATION AS A MEANS OF SOCIAL SELECTION. — Underneath all of the distinctions of the secondary stage of education previously discussed, lies one possessing the greatest significance and one operative over

the longest period. This is the view of secondary education as a means of selecting those most able and fit for social leadership of any type. This characteristic is involved in one of the distinctions already stated. It is really one way of stating that education is a preparation for professional life. But it is much broader than this professional conception, and works independent of it. It is probable that neither social nor educational leaders were conscious of this function until education had broadened beyond professional training. This greater breadth came definitely during the Renaissance-Reformation period. It was expressed by our Puritan forefathers in the phrase — “that learning might not be buried in the grave of our fathers in church and in commonwealth.”

To those who perpetuated the old Latin grammar school though conscious of its narrow conception of education, the institution was justified by its selective function. When the democratic spirit was increasing in the period previous to the nineteenth century, it was this function of the school that was deemed of greatest significance. This selective system worked somewhat ruthlessly, but nevertheless directly and efficiently, to its end. The Jesuit system avowedly rejected those of mediocre capacity and devoted its energies to those of superior abilities. Most of the Protestant systems more or less unconsciously and automatically did the same thing. Even in those countries where the autocratic spirit was comparatively wanting, as in Scotland, the entire attention of the secondary school was directed to “the lad o’ parts.”

The democratic criticism of the secondary school of this type is aimed not so much at its purpose of selecting only the fittest, but at its very narrow conception of abilities. The type of mind that responded to this peculiar discipline, rigid and thorough, was tested in a very narrow range. It still remains the accepted belief, both socially and educationally, in most of the European countries, that the secondary educational system is designed to select, by elimination or by

segregation, the intellectually ablest of the younger generation and to send them on, if not to prepare them directly for leadership in the various institutions of society.

On the other hand, it is obviously true that the American schools in emphasizing the democratic purpose have minimized this selective function of the secondary school. The tendency in our own schools is to devote more attention to the subnormal or to the mediocre than to the supernormal. It would be entirely possible to preserve both the democratic and the selective function of the secondary school if the false democracy which demands uniform treatment for all were replaced by the practice of differentiating students according to their interests, subject matter according to its social significance for the student taking it, and methods according to the individual abilities of the students.

SECONDARY EDUCATION BASED ON PHYSIOLOGICAL AND PSYCHOLOGICAL AGE. — With the growth of modern individualism and of the natural sciences, there came into secondary education an entirely new consideration. It is now known that during the adolescent period the child undergoes such a radical change, physically and psychically, that education can find in these changes the sufficient basis for a differentiation between the earlier and the secondary stages of education.

To Rousseau belongs the credit of first definitely emphasizing this fact. The European schools, based upon other traditions, hardly take these facts into consideration — at least as a basis for the differentiation of elementary and secondary education. The secondary education period begins in practically all European countries at about the ninth year of the pupil's age; that is, some four or six years before the American child enters upon this stage of education, and some years before adolescence.

Other reasons were more influential in setting the age limits of the American secondary school, but the general recognition of the peculiar interests, abilities, and characteristics of the

adolescent age has had much to do with determining these limits. While the democratic feature of elementary education is no doubt the determining factor in fixing the beginning of the secondary school period at about the fourteenth year, the recognition of the importance of the adolescent period has grown in weight throughout the history of the American high school. The old academies and the still older colonial Latin grammar schools took the youth much earlier than does the present high school.

That the influence of the adolescent factor has been stronger than most others is shown by the fact that foreign languages, science, and higher mathematics have been made to conform to this distinction, when experience, the conditions in other countries, and the interests of the child would dictate an earlier approach.

The seventh chapter of this volume gives an elaborate summary of the physical and psychical considerations which enter into the adolescent period and which must receive attention in determining the scope and character of secondary school work. Such considerations are becoming more and more influential and should be studied as a prominent, though not the sole, factor in determining problems of secondary education.

SECONDARY EDUCATION DETERMINED BY THE STUDENT'S INTERESTS AND ABILITIES.—A factor of increasing importance in determining the scope and purpose of secondary education is that embodied in the interests and abilities of the students. In considering its selective function as the determining element in secondary education, it was noted that the interests and abilities of only a very limited class of students were considered. But as a result of the increased attention given to the physical and psychical characteristics of adolescence as well as of the growing diversification in the needs of society, a wider range of student interests and abilities was provided for. This was the characteristic contribution of the

academies. The courtly academies of the continent, the non-conformist academies of England, the early American academies, all catered to the interests of the students. So marked a feature did this become, especially in the American academies, that it resulted in what might be termed "local option" or even "personal option" in education. "If you do not see what you want in the curriculum, ask for it," was practically the working basis of many of these institutions. Such freedom and absence of standard could but be a passing phase, even though it emphasized a much-needed principle of operation.

A more stable and socially serviceable form of response to this same demand was made in the continental countries of Europe, especially among the Teutons, by the development of divergent types of secondary schools. Thus in time the German states added to the *gymnasium*, the *pro-gymnasium*, the *real-gymnasium*, the *ober-real schule*, the *fortbildung schule*, and the several forms of the technical and the commercial schools. Scarcely an interest or an ability of the adolescent fails to find an opportunity for expression and training in this diversified system.

The American high schools attempt through a variety of alternative courses to meet the same need. These courses, however, are of such general nature that the schools do not function so efficiently as do the continental ones.

THE PRESENT IS A COMBINATION OF ALL THESE FACTORS. — At the present time all of these factors enter into a determination of the scope and purpose of secondary education. Hence arise the complexity of the problem, the lack of agreement among those engaged in the work of secondary education, the absence of a common procedure or organization. Added to this fact is the other consideration that society is much more complex, and the individual has much greater liberty of choice and opportunity, than in any past stage. Consequently it is impossible to state in simple terms the

problem of secondary education or to delimit with any great precision its scope and purpose. These are, or may be, as varied as the needs of society and the interests and abilities of the students. Any theoretical formulation of principles and any practical organization of procedure must take account of all these factors.

Some consideration must be given to the fundamental difference in methods between the elementary and the higher stages of education. While all school work has become primarily a matter of instruction, yet the element of rational interpretation of experience as a basis for future conduct must be made the guiding principle of method in the secondary stage. So to formulate the work of the secondary school that such rationalized intelligence will result is now recognized as one of the chief tasks of the educator. The stress placed upon method in the chapters on the natural and the social sciences as well as in the concluding chapter of this volume is in recognition of this fact.

The differentiation of subject matter is and must continue to be one of the determining factors in secondary education. But the practical demands that foreign languages, the higher phases of mathematics for some children, and the natural sciences taught by inductive methods for all children, should be begun much earlier, will probably bring in the United States a gradual lowering of the age of entrance to the secondary school.

In nearly all countries the completion of a secondary school course is the prerequisite for admission into most professions or professional schools. The present tendencies are all in the direction of making this requirement more general. No doubt in time such a requirement will become universal in the United States as it has in the Teutonic countries of Europe. Any consideration or any organization of secondary education must include this as a definite factor.

The secondary stage of education continues to be a form of

class distinction. And the conservation of social forces may well continue this influence. However, it should not be merely the badge of a leisure class. It should rather become, through a greater precision in the social functioning of the secondary school system, an index of efficiency in the various classes and groups in society.

In European countries the secondary school continues to function as an instrument of social selection, and the tendency in our own country is in that direction. Social selection may work, however, not only by elimination, but by segregation. It is with difficulty that a democracy realizes the fact that social democracy and social stability depend upon specialization and upon efficient development of individual ability. The guiding principle cannot be to treat all students alike, but to develop as many specialized lines of training as the community can support. There is now in our country greater need than ever for the training of leaders and for an instrument of social selection. The haphazard methods of the past are proving too wasteful to be long continued. National if not individual competition will force such specialization and definite training upon us. The intelligence which demands the best training of the efficient must be joined to the prevailing sentiment for the education of the subnormal if our country is to hold its own as the advantages due to our unlimited natural resources gradually disappear. The selection and the training of the socially efficient or the supernormal is probably the factor that needs most stressing in the present state of our secondary education.

The psychical and physical factors influential in secondary education have never before received so much consideration as is now being given to them. The careful continuous study of these factors cannot but throw light upon the whole problem, despite the number and the importance of the other factors.

Similarly, students' interests and abilities are receiving unprecedented attention. And this must be continued. Such

consideration bids fair to bring about a much greater diversification in our secondary education than we have ever had.

SECONDARY EDUCATION AS A PREPARATION FOR SOCIAL SERVICE AND A TRAINING IN EFFICIENCY.—

All the factors of the past are now present and operative. This fact in itself would seem to be sufficient to explain the complexity and the importance of the present problem in secondary education. But to these is added one other, an entirely new one and a dominating one.

This fact is that there is a dawning perception that secondary education must become universal as elementary education has now become. This situation is not clearly recognized, but its existence explains much of the uncertainty and much of the difficulty of the present.

In all of the highly developed modern societies the inadequacy of the existing form of elementary education is being recognized. In addition a special vocational training is needed for the rank and file of society workers; and the selected leaders in professional or vocational activities of a higher social and intellectual status should have a broader general education as a basis for their subsequent vocational training.

Hence in European countries extended systems of diversified secondary schools have developed, including not only the varied forms of schools preparatory to the professions and to scientific employments, but a like variety of technical vocational schools for those engaged in common industry of any form. Several German states and other Teutonic countries make it incumbent on practically every individual entering into industry or commerce to take such training. That for the higher professional and scientific employments has long been obligatory.

In English-speaking countries, more jealous of individual initiative and of freedom from regulation, the development has been much more tardy. In our own country the pressure of complex social conditions has also been much less. Con-

sequently the development of a variety of vocational continuation schools of secondary character has but just begun. The demand for the universality of secondary education is indicated by the growing recognition of the necessity for such schools throughout our own country, as well as by the greatly increased attendance upon our present secondary schools and by the variety of attempts to diversify the course of study in the traditional schools. If such diversification were adequately provided for, both through varied courses and through new types of schools less bound to traditional methods, the attendance upon secondary schools would become vastly greater.

But our own country will realize in time, as the countries of continental Europe have already done, that this matter cannot be left to individual interest and choice. The interests of society demand such advanced and more specialized training for all its members. Granting that there are still great numbers who are free from the necessity of a definite vocational training, an advanced training for the benefit of those possessing leisure is just as essential, if they are to be socially efficient.

For women, whether in vocation, or responsible for the home, or belonging to a leisure class, the same need is becoming evident. And no doubt the educational aspect of the present "woman's movement" will become more and more distinct as experience adds its influence to *a priori* arguments.

The concluding chapter of this volume presents this view of the universalization of secondary education, not only in its opportunities but in its realization, in the form of an argument in terms of social efficiency and service. In time this argument of expediency will become one of necessity, as society in America becomes subject to somewhat more of the economic pressure that exists in other countries, and as political, economic, and social problems take a more definite and concrete form than they now have.

CHAPTER II

HISTORIC SKETCH OF SECONDARY EDUCATION

ORIGIN OF THE DISTINCTION BETWEEN ELEMENTARY AND SECONDARY EDUCATION. — The distinction between secondary and elementary education first arose with the Greeks. On the practical side this distinction grew out of the transition from the simple life of the old Greeks to the complex conditions of later Greek society. Increase of wealth, of leisure, of luxuries, and of democratic political power and the decline of military interests characterized the latter and called for a new education. On the theoretical side the distinction grew out of the reflective consideration by the philosophers of educational processes. They recognized the difference between the simple habit-formation in the home life of their early generations and the artificial processes of instruction necessary for skilled and specialized participation in a highly developed society.

Origin of the Practical Distinction. — Old Greek education, like all other forms of education in early stages of historic growth and in simple social life, was a training in habits of conduct. The traits of character which the Greeks valued in an individual were courage, temperance, reverence, and good practical judgment. These traits when developed in an individual produced in him that marked personality which was valued by the Greek. They gave to the individual possessing them a social value which entitled him to become a member of the group. In a simple society where agricultural or pastoral pursuits were the chief occupation of private life and military activities the chief public duties, and where slaves performed most menial work, little differentiation of social classes would

exist. Without any great distinction of social classes or of economic and social activities, little differentiation in education could take place. So long as education was conceived in terms of the virtues of conduct, the processes of education were largely those of a "doing" as opposed to those of a reflective kind. The simple means which the early Greek used to secure these several results in habit-formation were music and gymnastics. It is a striking fact that the people commonly held to be the most cultured and intellectual of all peoples had until late in their history little if any of that linguistic or literary training which in all subsequent schemes has been made the basis of all cultural education. The culture elements which in the Greek scheme were the products have been made the means in all subsequent schemes.

Plato says of this stage, "Education has two branches: one of gymnastics, which is concerned with the body, and the other of music, which is designed for the improvement of the soul." Gymnastics he then divides into wrestling and dancing. The ordinary Greek curriculum was running, jumping, wrestling, throwing the javelin, and boxing. Music in the schools was no less a "doing" process. It consisted in repeating poetry to a musical improvisation which would express the emotional content of the poem.

While this education in habit-formation through the use of music and gymnastics flourished, the simple society which gave it birth was giving way to a much more complex one. In the political world the old aristocracy was passing away and a democracy of free citizens, exercising very great direct powers over the wealth, the individual liberties, and the personal welfare of its members, was taking its place. On the economic side trade and commerce had developed, and the classes pursuing these interests came to replace in power those whose economic basis was in agricultural or pastoral interests. Following a period of economic expansion and of division of labor, a great variety of new social and industrial activities

sprang up. A period of great military activity was followed by one of expansion of national power, with its opportunities for realization of personal aims, for revelation of political ability, and for personal aggrandizement through the direction, or manipulation of public affairs. Small city-states now were replaced by a great Grecian people with a common culture, a broader horizon, and a larger social opportunity. This meant a closer contact with foreign ideas and customs and a consequent toleration. A reflective as well as a cultural literature developed. Religious ideas changed, old customs lost their compelling force, old ideals failed. The old theology or mythology was completely undermined, with a resulting change in philosophy and literature as well as in morals and religion. In this new world the traditional education of training in habits of action in conformity with certain simple fundamental moral ideals lost its force.

Out of this situation, secondary education as a practical process evolved. Neither the old philosophy and religion nor the old-fashioned training sufficed for the new needs. The demands on education made by these social changes—political, economic, ethical, literary, and the like—were twofold. There was first a demand for greater freedom for the individual in action and thought, to correspond with the growth of freedom in the political sphere. Second, there was a demand for training or education that would enable the individual to take advantage of the unprecedented opportunities for personal achievement and aggrandizement. Ability to discuss all sorts of social, political, economic, and scientific or metaphysical questions; to argue in public in the market place or in the law courts; to declaim in a formal manner upon almost any topic; to amuse or to instruct the populace upon topics of interest or questions of the day; to take part in the many diplomatic embassies and political missions of the times,— was now demanded. In fact, the demand was for an ability to acquire wealth or to command the approval and control the

votes of an intelligent democratic society much like our own; where, however, the functions of printing press, telegraph, railroad, and all modern means of communication were performed through public speech and private discourse, and where legal, ecclesiastical, and other professional classes of teachers did not exist. The old Athenian state made no provision whatever for higher intellectual training of a formal kind, but it did offer opportunity for such development in the freedom it gave to the individual during the period of his training in the gymnasium and after the military training of the Ephebic period.

Whether approached from the theoretical or from the practical side, the formal subjects of study became the basis of the new education. Out of the social and intellectual changes noted grew new subjects, foreign in character to the simple music and gymnastics of the early period. Grammar, the form and arrangement of language; rhetoric, the form and arrangement of written or oral speech; logic or dialectic, the form and arrangement of thought,—were the contributions of the sophist, the rhetorician, and the philosopher of this period. These formal or abstract studies, modifying or determining habits of thought rather than habits of action, now became the basis of education. Grammar and rhetoric, relating more directly to everyday life as participated in by the orator, became the practical aspect of secondary education. Logic or dialectic, concerned with the reflective or thought life, became the basis of the theoretical phase. Each produced its own type of school. The rhetorical school and the dialectic or philosophical school long persisted; the grammar school remains to the present day.

Origin of the Theoretical Distinction.—The theoretical distinction between elementary and secondary education arose with those Greek thinkers who contemplated the conflict arising in this transition from a simple society to a complex one wherein individualism had undermined most of the old social

standards, and who also saw this conflict between the practical and the theoretical aspects in the earliest differentiation of secondary education. In the *Republic* (Bk. VII) Plato seeks for a scheme of education adequate to produce the rulers of society, a scheme which would not only cultivate the virtues demanded under the old régime, but which would also give knowledge and develop virtue and disinterestedness. Music and gymnastics he considered inadequate and the useful arts demeaning. But he declares in favor of the "study of the kind which leads naturally to reflection but which seems never to have been rightfully used; for the true use of it is to draw us towards being (abstract thought)." He finds that arithmetic, geometry, astronomy, and harmony comply with these requirements. These in turn are to be used primarily as an introduction to the study of abstract ideas, "in which if one perseveres, he attains by pure intelligence to the idea of good and finds himself at the end of the intellectual world."

Aristotle first formulated this distinction in his psychological analysis:

"There are three things which make men good and virtuous: these are nature, habit, reason. In the first place, every one must be born a man and not some other animal; in the second place, he must have a certain character, both of body and of soul. But some qualities there is no use in having at birth, for they are altered by habit, and there are some gifts of nature which may be turned by habit to good or bad. Most animals lead a life of nature, although in lesser particulars some are influenced by habit as well. Man has reason, in addition, and man only. Wherefore nature, habit, reason, must be in harmony with one another—for they do not always agree; men do many things against habit and nature, if reason persuades them that they ought. We have already determined what natures are likely to be most easily molded by the hands of the legislator. All else is the work of education; we learn some things by habit and some by instruction."

This distinction of Aristotle's brings out most clearly the fundamental difference in practice between elementary and secondary education with the Greeks. The former was primarily the formation of habit through athletic activities, the singing of songs, the memorizing and repetition of poetic legends, and the improvisation of a musical accompaniment. Gracefulness in movement, courage and quick decision in danger, endurance under physical hardships, reverence for elders and for things sacred, obedience to authority, devotion to the state, good judgment in practical affairs, temperance in all forms of personal pleasure or relaxation, were thus to be obtained.

But the formation of such habits no longer sufficed to equip a youth to enter the changed social life. He must have guidance in adapting himself to new and changing conditions. He needed not only to form such habits, adequate under the old conditions, but to develop the power to modify his habits or to form new and more complex ones, to meet new and complex situations. Therefore he needed instruction as well as training. Herein lies the fundamental distinction between the two stages of education. Elementary education looked to the formation of habits by the process of training; secondary education sought to develop general intelligence by the process of instruction.

Aristotle further elaborates this distinction on the ethical and philosophical side. In his ethical theory he has defined goodness as the harmony between the organ or organism and its purpose or function, and has discovered two kinds of goodness. There is goodness of being and goodness of doing; goodness of thinking and goodness of acting; goodness of intellect and goodness of character. The special function of the higher stage of education is to secure this goodness of intellect; to provide the rational basis for conduct; to furnish the intellectual preparation for the proper functioning of the individual in society.

THE SECONDARY SCHOOLS OF GREECE. — The practical elaboration of these educational processes early evolved in Greek experience the same problem which confronts the modern educator. Are these needs of society and of the individual best met by a process of instruction which deals wholly with the interpretative aspect of experience more or less remotely connected with the actual situations of everyday life? Or is it better met by a schooling which contains large elements of training in the actual application of the products of instruction through activities which closely resemble the ordinary social routine, if they are not actually a part of it? Hence arose the two types of schools, the philosophical or dialectic and the rhetorical.

The Philosophical Schools. — The more important of the philosophical schools were the Academician, the Peripatetic, the Stoic, and the Cynic. But there were others of less significance. And of even greater importance to the youth entering this stage of education were the numerous preparatory schools either connected with these advanced schools of philosophy or independent of them. They gave the grammatical training essential to entrance upon the logical or philosophical discussions and gave also the rudimentary training along these lines. The Platonic dialogues and the Greek philosophical literature in general are the products of these higher schools and represent their work at its best. They also indicate the simplicity of organization in these schools, the informality of method, the general vagueness or abstractness of their content of instruction. That the majority of such schools were inferior to these four more noted ones is indicated by the variety of criticisms directed against the work of the Sophists, most of whom after all belonged to this group of teachers.

The Rhetorical Schools. — These were of a far more practical character. While they gave instruction in grammar and literature, their characteristic work was the actual train-

ing in declamation and in oratory. The ordinary school — the grammar school or school of letters — also frequently taught arithmetic and geometry. But a practical training in the use of language as a means of influencing one's fellows, of defending one's rights, and of furthering one's own interest in public and business life was the chief aim.

Of the method of procedure of these schools we have some indications left. There were various types of oratory in which the youth were trained. Chief of them were the forensic, the deliberative, the apologetic, the expository. Specimen subjects of such exercises are mentioned. The speeches of the Sophists referred to in Plato, those of Socrates, and the lectures of Aristotle furnish examples of these discourses in their perfected form.

Little is known of the organization of these schools. In the later period, in the flourishing period of the so-called University of Athens, numerous tutors, some affiliated with the professors of the University, some independent, were found in connection with this crowning institution of the Greek educational system. In other Greek cities similar schools flourished.¹ However numerous and prosperous the schools of this type, it does not appear that the state ever extended any support or supervision to them. To the Sophists, the rhetoricians, and the philosophers of the University teaching staff, the Greek state and later the Roman government gave both oversight and financial assistance. In the long transition period between the time when the Ephebic training was wholly military, physical, and civic to the time when it had become wholly literary under the University faculty, the Athenian government continued to exercise control over the native youth who chose to strive for this type of education. But as it took on a literary character, this stage of education ceased to be compulsory. At the same time it came to be

¹ See Walden, *Universities of Ancient Greece*.

sought after by non-Athenian youth and so ceased to be distinctive.

However, in the very early stages of the differentiation of these two types of education, the defects which are yet attributed to them aroused criticism. The literary, philosophical or dialectic education was held to be abstract, theoretic, and impracticable. The rhetorical schools were regarded by the advocates of the other type as materialistic, illiberal, or even as tending to lower the whole moral tone of society.

Thus for both theoretic and practical aspects, Greek education and Greek experience outlined the present problems of secondary education.

THE ROMAN SECONDARY SCHOOL. — The Romans accepted the Greek educational system, particularly that portion of interest in this study, with little modification. They added little to it of significance to modern times. They systematized and perfected curriculum and method; and in the latter period of their history they built up a system of schools, some remnant of which persisted long into the Middle Ages.

The historian Suetonius, writing about 121 A.D., gives as explicit an account of the beginnings of secondary education in Rome as one can now give.

“ The science of grammar was in ancient times far from being in vogue at Rome; indeed, it was of little use in a rude state of society, when the people were engaged in constant wars, and had not much time to bestow on the cultivation of the liberal arts. At the outset, its pretensions were very slender, for the earliest men of learning, who were both poets and orators, may be considered as half-Greek: I speak of Livius and Ennius, who are acknowledged to have taught both languages as well at Rome as in foreign parts. But they only translated from the Greek, and if they composed anything of their own in Latin, it was only from what they had before read. . . . The appellation of grammarian was borrowed from the Greeks; but at first the Latins called such persons *literati*. . . . The early grammarians taught

rhetoric also, and we have many of their treatises which include both sciences; whence it arose, I think, that in later times, although the two professions had then become distinct, the old custom was retained, or the grammarians introduced into their teaching some of the elements required for public speaking, such as the problem, the periphrasis, the choice of words, description of character, and the like; in order that they might not transfer their pupils to the rhetoricians no better than ill-taught boys."

The Grammar School then became the dominant type. For while the rhetorical school was often added as a superior school, yet more frequently, especially when preceded by the *ludus*, or elementary school, the grammar school added on the rudiments of rhetorical training, by giving the youth practical training in declamation and oratory. The grammar school was of two types: one teaching Greek, the other Latin. About 161 B.C. the Senate decreed "that no philosophers or rhetoricians be allowed in Rome." And in 92 B.C. a similar action regarding Latin rhetoricians was taken by the Censors. This indicates the foreign origin of the formal Roman education, its effect in undermining old custom, and its purpose in preparing youths to avail themselves of new opportunities. By the close of the first Christian century the grammar school, subsidized if not supported by the state or the municipality, became a common feature. Before the decline of the Empire their existence may be said to have been universal. In 376 the Emperor Gratian determined the schedule of salaries and assigned the grammar teachers a place in the municipal budgets. The grammar school master was to receive a stipend 20 times as great as the annual wage of the ordinary workman, and the rhetoric master one 24 times as large.

The Curriculum was elaborated and crystallized in the form which it retained until the Renaissance. The grammar and the rhetoric of the early centuries were evidently very simple. But when Cicero's *De Oratore* was published (55 B.C.)

— though Cicero represented a foreign training — grammar and rhetoric had come to include all literature, or at least a very broad literary training. With the *De Oratore* of Tacitus (79 A.D.) and the *Institutes* of Quintilian (96 A.D.), this curriculum, still literary, contained history, poetry, philosophy, and the entire range of subjects then known. In fact the liberal arts were not yet limited to seven, but included architecture, medicine, and philosophy, along with grammar, rhetoric, dialectic, arithmetic, geometry, music, and astronomy.

While this wide range of subjects was held up as the proper preparation of the true orator, it is evident even from these treatises which expound the ideal, that the work of most, if not all, secondary schools was confined to a very narrow though thorough training in grammar and rhetoric. By the latter is meant both the practical training in declamation and oratory and the instruction underlying these. Of the scope of rhetorical training Cicero says :

“ In my opinion, indeed, no man can be an orator possessed of every praiseworthy accomplishment, unless he has attained the knowledge of everything important and of all liberal arts, for his language must be ornate and copious from knowledge, since, unless there be beneath the surface matter understood and felt by the speaker, oratory becomes an empty and almost puerile flow of words.”

The views of Tacitus are similar :

“ On the contrary, he alone can justly be deemed an orator, who can speak on every subject gracefully, ornately, and persuasively, in a manner suitable to the dignity of his subject, and with pleasure to his hearers. . . . Accordingly the ancient orators not only studied the civil laws, but also grammar, poetry, music, and geometry. Indeed, there are few cases (perhaps I might justly say there are none) wherein a skill in the first is not absolutely necessary ; and there are many in which an acquaintance with the last-mentioned sciences is highly requisite.”

As to the elaboration of the content of rhetoric it is sufficient to call to mind that Aristotle, Cicero, Quintilian, are not only the originators of this science, but are among the greatest authorities now quoted. The subject stands substantially to-day as it was elaborated by these writers. Nor is this Quintilian's only contribution to education, for his *Institutes* is not only the first but probably the most voluminous and detailed of the systematic treatises that have yet appeared on the whole subject of education.

Donatus (c. 400 A.D.) and Priscian (c. 500 A.D.) completed the systematization of the curriculum and organized the elements of literary education in the form in which they were transmitted to the Middle Ages. For several centuries their work constituted almost the entire structure of literary education. Boethius (c. 480-524) made a similar contribution in dialectic and philosophy. The work of these men brought the Roman epoch in education to a close, and epitomized its contributions to the curriculum.

The Roman Contribution to Method. — The Romans systematized method as they did the curriculum. Their writers have left concrete indications of methods used, from the learning of the alphabet to the study of philosophy. In fact Quintilian's treatise is chiefly a discussion of method. He would have the idea acquired with the form, would use means to arouse interest, would avoid compulsion, would have the study of Greek grammar precede that of Latin grammar. The detail with which this greatest of Roman schoolmasters treats the subject as well as the rational conclusions which he usually reaches may be judged from the introductory paragraph of the chapter on reading.

“ Reading remains to be considered ; in which how a boy may know when to take breath, where to divide a verse, where the sense is concluded, where it begins, when the voice is to be raised or lowered, what is to be uttered with any particular inflection of sound, or what is to be pronounced with greater

slowness or rapidity, with greater animation or gentleness than other passages, can be taught only in practice. There is but one direction, therefore, which I have to give in this part of my work, namely, *that he may be able to do all this successfully, let him understand what he reads. . . .* Other points demand much admonition to be given on them; and care is to be taken, above all things, that tender minds, which will imbibe deeply whatever has entered them while rude and ignorant of everything, may learn, not only what is eloquent, but, still more, what is morally good.”

With great detail, the curriculum of literature, grammar, rhetoric, music, philosophy, arithmetic, geometry, astronomy, and the entire range of ancient learning is presented. The content of these subjects, their educational value, the best methods of study and presentation, are considered. All these were essential for the orator; and the orator constituted the one type of educated man. He was the philosopher active in the affairs of life. This one profession comprised the entire range of the modern professions, — lawyer, statesman, publicist, teacher, editor or molder of public opinion, — even clergyman, for orators were the guardians of public morals. Cæsar’s well-known fondness for the public address is an evidence of the part which this ability played in the equipment of a man of affairs.

The relation of the processes of instruction to the processes of practical training in oratorical powers undertaken by the higher schools, with the resulting problems of adjustments, is thus stated by Quintilian :

“ It has been a prevalent custom (which daily gains ground more and more) for pupils to be sent to the teachers of eloquence, to the Latin teachers always, and to the Greeks sometimes, at a more advanced age than reason requires. Of this practice there are two causes: that the rhetoricians, especially our own, have relinquished a part of their duties, and that the grammarians have appropriated what does not belong to them. The rhetoricians think it their business

merely to declaim, and to teach the art and practice of declaiming, confining themselves, too, to deliberate and judicial subjects (for others they despise as beneath their profession), while the grammarians, on their part, do not deem it sufficient to take what has been left them (on which account also gratitude should be accorded them), but encroach even upon expository and deliberative speeches, in which the very greatest efforts of eloquence are displayed."

Thus we get a prevision of those problems of adjustment of the secondary stage of education to advanced schools and to practical professional demands which yet demand the teacher's attention.

Lists of subjects for debate, methods of training, forms of oratory, styles of address, are all given, indicating that greater attention was paid to the concrete details of this education than by modern law school or theological seminary, whose work would more nearly approximate that of the Roman schools of grammar and rhetoric than would that of the modern secondary school.

This contribution of the Roman school to organization and method, though its influence evidently pervaded the Empire during the centuries of its decline, lapsed for the greater part of the Middle Ages. But with the Renaissance, Quintilian's *Institutes* became both the guide of the new teachers of literature and the authority commonly referred to and followed by several generations of scholars and teachers, now recognized as composing a new estate in society.

THE MIDDLE AGES AND THE SECONDARY SCHOOL.

— Little of permanent value was contributed by the Middle Ages to the traditions of the secondary school. That little was through the influences making the work of the grammar school a direct vocational training. The rhetoric school died out. Rhetoric came to be limited to a training in preparing legal papers and records, conducting legal and political or diplomatic correspondence, and in general for the

secretarial work which included the genesis of many modern professional activities. Such training was given in the grammar schools under the title of rhetoric. Some little arithmetic, sufficient to calculate the calendar, with its numerous feast days, was also included. Logic or dialectic in the early Middle Ages was of little or no importance, and during the latter centuries of this period produced its own institution, the university. So the grammar school came to be the secondary school *par excellence* and continued to monopolize this field until a very recent date.

As the scope of rhetoric broadened during the Roman period to include the preparatory training for the wide range of professions, so did grammar undergo a similar expansion during the Middle Ages. Not only did it include rhetoric and the training of the clerk and secretary, the embryonic lawyer and diplomat; it provided in a similar way the training for the clergy, which profession then included the entire literary or learned class.

Types and Extent of these Schools. — The most important change which these schools underwent in the transition from the Roman period to the Middle Ages was that they passed from the control of the state to that of the church. This process was a gradual one in the Romanized population and occurred as the bishop gradually acquired the authority of the civil magistrates. In the population largely composed of the new Teutonic elements there were no schools to replace, and the rudimentary training in grammar or letters was sufficient, but at the same time essential. So the grammar school, now the bishop's or the episcopal school, became general throughout western Christendom.

This transfer took place during the sixth and seventh centuries. Though there is evidence that there was opposition upon the part of churchmen to the church's assuming this authority and responsibility, yet by the seventh century it seemed to be recognized as necessary, for as Isidore remarked,

“It is better to have grammar than heresy.” Under the title of grammar schools they are found in England under Augustine early in the seventh century. Alcuin’s school at York was a century later. A canon of 826, rescinded in 1073, required the maintenance of such schools by all bishops. By the latter period, however, a distinct officer of the bishopric, the chancellor, had been evolved, in whose hands was placed the direct responsibility for the bishop’s school and also for supervising all schools and licensing the schoolmasters.

Meanwhile schools in churches other than cathedrals were growing up. In churches having a collegiate organization or even in parochial churches with adequate chantry foundations, grammar schools were to be established. A decretal of 1215 indicates the application of this order to England and the general papal authorization upon which it is based.

“In every cathedral or other church of sufficient means, a master ought to be elected by the prelate or chapter, and the income of a prebend assigned to him, and in every metropolitan church a theologian also ought to be elected. And if the church is not rich enough to provide a grammarian and theologian, it shall provide for the theologian from the revenues of his church, and cause provision to be made for the grammarian in some church of his city or diocese.”

Meanwhile the monastic orders had come into control of many episcopal and collegiate churches and of the schools as well. Similar schools were frequently added to the organization of the monastic chapter. Schools were by no means a universal feature of monastic organization and were probably always inferior in importance to the bishops’ schools. They sometimes cared for boys outside their order, but oftener limited their attention to their own novices.

Free Schools and Endowments.—Two other changes occurred during this period which were of as fundamental importance as the transfer of the schools to ecclesiastical control. One was the growth of endowments for the support

of the schools, a support now rendered essential by the withdrawal of civil contributions. The other was that these schools became free, at least to a select number of pupils. This change was partially consequent upon the fact that these were church schools for the training of prospective members of the clergy, and partially consequent upon the growth of endowments and the stress laid by the medieval church upon the virtue of charity. Such endowments began when the bishop set aside a portion of the cathedral endowment for the support of the schoolmaster, who had been recognized for several centuries as a distinct officer. Before this the schoolmaster was maintained out of the general revenues, as were the remaining clerks and the canons. Gradually it became the custom for bishops and even for kings or private parties to establish such foundations for the schoolmaster. The decretal quoted on page 31 is probably the authority for the very general introduction of this custom.

This custom of endowing secondary education, which in the early days of the universities did not extend to higher education, was so extended when private parties came to make such gifts, either for the support, in whole or part, of institutions already existing or of masters already at work, or for the creation of entirely new foundations. A new epoch in education was opened by one of these latter foundations, that of William of Wykeham at Winchester in 1382. This foundation was made on such a scale that the educational features entirely overshadowed the ecclesiastical and the philanthropic, and in consequence Winchester is commonly held to be the oldest of the type of great Public Schools of England.

This feature of separate endowment was characteristic chiefly of England. But the general endowment of the grammar school or of the grammar school master through cathedral or monastic chapter or chantry foundation was found throughout Western Europe. Subsequent development takes one into the Renaissance-Reformation period.

It is presumably true that cathedral schools gave free instruction to the members of the bishop's entourage or to prospective clergy. But there are numerous indications that many masters taught grammar privately and that even the ecclesiastical foundations also had fees. The licensing of schoolmasters developed probably because of financial value of the monopoly as well as to preserve orthodoxy. When the period of endowments is reached, it is clear from the reading of the many deeds of gifts that their chief purpose was to furnish free educational opportunity, especially for poor youths. One of the best illustrations of this was Eton, founded by King Henry VI in 1440 for twenty-five "poor and indigent scholars to learn grammar" with "one master or teacher in grammar, whose duty it is to teach the said scholars and others whatsoever and whencesoever from our realm of England flocking to the said college in the rudiments of grammar, *gratis*, without the exaction of money or anything." Subsequent foundations of this type became more significant in the Renaissance and the Reformation period, though they were of great frequency in the closing centuries of the Middle Ages.

The Curriculum. — Alcuin enumerates the studies pursued at York in the eighth century, naming law, music, and theology in addition to the seven liberal arts. But this was beyond the range of most schools and of most scholars. Later, however, he calls the school a grammar school, distinguishing it from the song school. In this, as in all schools, the great emphasis was put upon grammatical texts with the numerous commentaries. Throughout these centuries and until the university period the chief distinction made was that between the grammar school and the song school. The following excerpt from an ordinance of 1477 will make this distinction clear:

"*Ordinance.* And that the grammar schoolmaster shall henceforth have the jurisdiction and government of all scholars

in the liberty and precinct of this town, except the petties called ABCs and song, taking only for his fees, from every grammar scholar, psalter scholar, and primer scholar according to the scale fixed by the lord Bishop of Norwich, viz. for a grammarian 10*d.*, psalterian 8*d.* and primarian 6*d.* for quarterage."

The curriculum of the medieval grammar school was as restricted as the term indicates. Dialectic or logic became of importance only with the universities. Rhetoric, as indicated above, was restricted to technical legal preparation of a rudimentary character. The content of grammar school education was the content of grammar. Fortunately that was broader than the present use of the term indicates; for within its scope was included all that those periods knew of literature. The advanced text most commonly used was Priscian, which was quite a thesaurus of Latin literature, particularly of Vergil:

Method. — The medieval school added little of permanent value to method. The first months, or even years, were devoted to Donatus — the "dry bones" of linguistic rules, definitions, and paradigms. This was mastered by sheer effort of memory. Later texts, for instance the *Doctrinale* of Alexander de Villa Dei, attempted to lighten this work through versification; as the *Distyches* of Cato did, for example, for vocabulary purposes. The catechetical form is found in some texts and towards the close of this period was widely used in the schools. The various texts written by Alcuin offer an example of the crudest kind. The dialogue form was also used as well as that of formal address woven into literary text. When schools became well developed in the latter part of the period, an elaboration of method occurred. The favorite form became that of "apposition," wherein teacher and pupil carried on a spirited debate concerning rules, verbal forms, interpretation, etc. No doubt in its earliest stages this was pure memory work upon the part of

the pupil and scarcely differed from the catechetical method. But skill and confidence developed with training, and the contest became one of genuine "apposition." All teaching was by individual instruction.

The refinement of method with advanced students was the application of the various forms of interpretation to literary passages or sentences or words. These forms of interpretation were the literal, the allegorical, the moral, and the mystical or anagogical. The significance of these various types of method can best be given in the words of the greatest intellect and teacher of the Middle Ages. In *The Banquet*, Dante says:

"I say then, as is narrated in the first chapter, that this exposition must be literal and allegorical; and to make this explicit one should know that it is possible to understand a book in four different ways, and that it ought to be explained chiefly in this manner.

"The one is termed literal, and this is that which does not extend beyond the text itself, such as is the fit narration of that thing whereof you are discoursing, an appropriate example of which is the third song, which discourses of nobility.

"Another is termed allegorical, and it is that which is concealed under the veil of fables, and is a truth concealed under a beautiful untruth; as when Ovid says that Orpheus with his lute made the wild beasts tame, and made the trees and the stones to follow him, which signifies that the wise man with the instrument of his voice makes cruel hearts gentle and humble, and makes those follow his will who have not the living force of knowledge and of art; who, having not the reasoning life of any knowledge whatever, are as the stones. And in order that this hidden thing should be discovered by the wise, it will be demonstrated in the last treatise. Verily the theologians take this meaning otherwise than do the poets; but, because my intention here is to follow the way of the poets, I shall take the allegorical sense according as it is used by the poets.

"The third sense is termed moral; and this is that which

the readers ought intently to search for in books, for their own advantage and for that of their descendants; as one can espy in the Gospel, when Christ ascended the Mount for the transfiguration, that, of the twelve Apostles, He took with Him only three. From which one can understand in the moral sense that in the most secret things we ought to have but little company.

“ The fourth sense is termed mystical, that is, above sense, supernatural; and this it is, when spiritually one expounds a writing which even in the literal sense by the things signified bears express reference to the Divine things of eternal glory; as one can see in that song of the prophet which says that by the exodus of the people of Israel from Egypt Judea is made holy and free. That this happens to be true according to the letter is evident. Not less true is that which it means spiritually, that in the soul’s liberation from sin (or in the exodus of the soul from sin) it is made holy and free in its powers.

“ But in demonstrating these, the literal must always go first, as that in whose sense the others are included, and without which it would be impossible and irrational to understand the others.”

THE SECONDARY SCHOOL IN THE RENAISSANCE-REFORMATION PERIOD. THE LATIN GRAMMAR SCHOOL. — During this period there developed two types of secondary school which persisted throughout the modern period and with some changes form the leading types to-day. The dominant type was the Latin grammar school, which took its place in the developing national systems as the prevailing form of this school. In the growing state systems it became the central core. It made the most general appeal of all schools, opened its opportunities to all who were competent to do its work and, at least in the opinion of educators in its day, offered an intellectual training which prepared for all the higher activities of social life. While universally planned as the Latin grammar school, it received different national titles: the *Ginnasio* in Italy, the *Gymnasium* in Germany, the *Lycée* in

France, the Public School in England, the Grammar School in the American colonies. The term "college" was occasionally used in each of these countries.

The Latin school remained the dominant type and the bearer of educational traditions through the modern centuries. It became the most stable, and socially and politically the most significant, part of the national school system. Its procedure was perfected, its method established, its curriculum fixed, its prestige rendered all powerful and its conserving influence profound. For many generations, even for many centuries, the Latin grammar school determined the view of education held by the teaching profession and by the public in general.

The Establishment of Schools. — The outstanding feature of the Renaissance period was the creation of a very general interest in literature, in culture in general, and in the development of literary schools. It may be said, on the contrary, that this new interest resulted at most in the creation of a small group of literary men, who at best had slight influence on the life of the community and the course of history. Previous to the Renaissance there had existed a literary education for a small group of clerks including some of the clergy and the secretarial profession, and a practical training in military activity and in forms of courtesy for the gentry. With the decay of feudalism and chivalry, the Renaissance added the literary element to the education of the nobles and gentry and enlarged this group capable of attaining a literary education to include not only all the gentry, but even selected boys of the burgher or of the poorer classes. It seems probable that this proffered opportunity to the middle and lower classes, received with enthusiastic approval in the early Renaissance, later on came to be viewed with disappointment or with indifference by the burgher class. It was expensive; it consumed long years; it was of direct value only in limited spheres; especially in commercial fields, with the development of the vernacular,

its use declined much earlier than in other phases of social activity.

But the Reformation coöperated with the Renaissance in fostering the linguistic type of education. Literary and textual studies came to have unique importance because of their bearing on religious belief. Scholastic ability, fostered by grammatical and rhetorical as well as by dialectic studies, was thus developed. A general dissemination of literary ability now became a thing to be desired. The ideal of life as a discipline held by the religious leaders coincided with both the concept of education and the actual practices of the school.

Numerous formulations of the aim of these schools are to be found in the literature of the time. Practically all of them agree in including the elements of knowledge, piety, and eloquence. The first indicated an ability to read, write, and speak the Latin language and perhaps a knowledge of the content of Latin literature; by piety was meant a familiarity with the Scriptures, the catechism, credal forms, and ecclesiastical ceremonies, all gained more or less directly through the school; by eloquence was meant an ability to use the Latin language effectively in public activities.

Number and Type of Schools. — As a general result of the Renaissance-Reformation the control as well as the character of the secondary school was changed, and the number of these schools greatly increased.

In most continental countries, at least in occasional instances, municipalities had assumed the support of secondary schools and had acquired substantial control. In England control by trusteeship, of fellows, usually ecclesiastics, was the common form. In numerous instances guilds had established such institutions. But the commoner form was that of the cathedral or collegiate church, of chantry foundation, or of monastic order. In all cases the church claimed the right of licensing teachers and usually the right of visitation. In substantially all cases it made good its claim.

The humanistic school of the early Renaissance was attached to the court of a royal or noble patron, or was held in the home of the humanist scholar, as in the cases of Barzizza and Guarino. The early ones in Germany were under municipal or noble patronage, as were some in France. In England the typical form continued to be that of control by independent boards of feoffees, fellows, or tutors.

During the Reformation period those of Germany were developed into state systems, beginning with Saxony in 1528. The free cities continued as patrons of these schools, and in the state systems the municipalities were largely responsible for support and the church for supervision. In the Calvinistic countries — Switzerland, Holland, and Scotland — church and state coöperated. The provisions for these schools are usually found in ecclesiastical ordinances. The English system of control underwent but little change, though there was much destruction attending the Reformation; and in the subsequent period there were many new foundations or refoundations by private patrons and by monarchs.

It is contended that the facilities for education during the sixteenth century were greater than they were until very recent times. Mr. Leach in his study of the grammar schools of England in the sixteenth century estimates that in 1546 there were at least 300 such schools. He indicates the records of fully 200. The population of England at that time is estimated at 2,500,000. This estimate would give one grammar school for every 8300 inhabitants. In 1865 the Parliamentary School Inquiry Commission found 830 secondary schools of all grades, which would give one school for 23,250 inhabitants.

In Germany, Professor Mertz found 342 Latin schools in the German states during the sixteenth century. According to the estimated population of Germany at this time, Germany possessed one Latin school for every nine or ten thousand inhabitants. In 1910 there were 371 gymnasia and pro-

gymnasia in Prussia with population of 37,200,000, or one for every 100,000 inhabitants.

Curriculum of the Latin Grammar Schools. — An abundance of evidence concerning the course of study of the Latin schools drawn from widely divergent areas is available. The most striking characteristics of these courses of study are their similarity and their narrowness or intensity. Brinsley in his *Ludus Literarius* (1612) refers to the universal neglect of arithmetic in these schools: "Insomuch, as when they (the people) hear the chapters named in the church, many of them cannot turn to them, much less to the verse. . . . You shall have scholars, almost ready to go to the University, who yet can hardly tell you the numbers of pages, sections, chapters, or other divisions in their books, to find what they should." And almost as neglected is the art of writing. In the same treatise he says: "You shall find very few good writers in Grammar schools; unless either they have been taught by scribes, or be themselves marvelous apt hereunto, and very rare, or where the master doth apply himself chiefly to teach to write."

If this was the case concerning the two practical subjects of most immediate value and availability, no further question needs to be raised concerning subjects as yet hardly possessing an organized form. Many of these advocates would rule out Greek; many would add it. The vernacular has a place from the method point of view, but not as a recognized part of the course of study.

Sturm's curriculum at Strassburg in 1565 was as follows:

10th Class: Latin alphabet; reading.

9th Class: declensions; conjugations; irregular forms; vocabulary of common speech.

8th Class: Latin syntax; *Epistles* of Cicero with grammatical construction; exercises in style.

7th Class: Latin syntax; *Epistles* of Cicero; exercises in style; translation of catechism into Latin.

6th Class: *Epistles* of Cicero; Martial; Horace; catechism; Hieronymus; begin Greek.

5th Class: Versification; Cicero; Vergil, *Eclogues*; Donatus, ex tempore translation; Pauline *Epistles*; Greek.

4th Class: Cicero; Horace; Greek; Pauline *Epistles*.

3d Class: Latin treatises on rhetoric; Demosthenes; Homer; Pauline *Epistles*; double translations, Greek and Latin; Terence and Plautus to be acted.

2d Class: Comparison of Latin and Greek authors; logic; rhetoric; *Epistle to Romans*; acting of Aristophanes, Euripides, Sophocles, Terence, and Plautus.

1st Class: logic, rhetoric, and oratory in Latin and Greek; with more intensive study of above authors.

The curriculum of the Protestant School at Geneva, the Collège de la Rive, 1559, was as follows:

Classis VII. In this class the pupils will learn the letters, and write them to form syllables, using a Latin-French reading book. Reading French, and afterwards Latin from a French-Latin catechism: drawing, and writing letters of the alphabet.

VI. Declensions and conjugations are begun. Parts of speech learnt in French and Latin: more practice in handwriting: easy Latin sentences learnt orally and repeated as practice in conversation.

V. Parts of speech finished: elements of syntax: the *Eclogues* of Vergil read: Latin composition: Latin and French employed side by side.

IV. Latin syntax continued. Cicero's *Letters* begun; composition exercises are based on these. Prosody, with reading of Ovid. Greek begun: declension and conjugation; elementary construing.

III. Greek grammar systematically learnt. Cicero, *Letters*, *De Amicitia*, *De Senectute*: these two treatises to be turned into Greek. The *Æneid*, Cæsar and Isocrates read.

II. Chief stress laid upon reading: Livy, Xenophon, Polybius, Herodian, and Homer. Logic begun: propositions, syllogism: to be illustrated from Cicero's *Orations*. Once a week the Gospel narrative in Greek.

I. Melanchthon's *Logic*; the elements of rhetoric in connection with it; and elocution. Cicero's *Orations*: Demosthenes (the *Olynthiacs* and *Philippics*). Homer and Vergil also analyzed for rhetorical purposes. Two original "declamations" are prepared monthly. Once a week an *Epistle* of St. Paul or other apostle is read in Greek.

The curriculum of the Collège de Guyenne at Bordeaux in 1572 was as follows:

10th Class: alphabet; *Pater Noster*; psalms; *Ave Maria*; *Libellus Puerulorum* (a little summary of inflections of regular nouns and verbs).

9th Class: the two manuals referred to above, Cato's *Disticha*; Cordier's *Exempla*.

8th Class: Cicero's *Letters*; Cordier's *Colloquia*; Terence.

7th Class: Cicero's *Letters*; Latin grammar, and as above.

6th Class: mainly as above.

5th Class: as above; Terence; Ovid.

4th Class: Cicero, *Orations*; Erasmus, *De Copia*; Ovid; composition, Greek.

3d Class: Cicero; Terence; Ovid; composition; disputation.

2d Class: Cicero; Ovid; Vergil; Lucan; composition, declamation; rhetoric.

1st Class: as above; Quintilian; Livy; Seneca; Justin; Eutropius; Vergil; Lucan; Juvenal; Horace; and a variety of other classical and patristic authors.

Method of the Grammar Schools.—As there was a general conformity and an elaboration of curriculum, so was there of method also. The teaching of Latin attained a perfection, or at least an efficiency, which it has not altogether lost. No other subject was adequately organized. The natural sciences were not even recognized by the schools; consequently they developed no method. The literature on method is as extensive as that on the curriculum. But only the essential characteristics need to be enumerated here. The curricula abstracted above indicate thoroughness, procedure

by slow steps and brief lessons, frequent reviews, and above all else an actual use of the forms of the Latin language in conversation, in writing, and in formal speech such as declamation and oration.

The writings of Erasmus, of Melancthon, of Brinsley, of Sturm, of Ascham, of Hoole, of Corderius, of Vives, and of a great number of others give us details of method and many suggestions pertinent and valuable for the teacher of languages even at the present time. And yet it is evident that in the teaching of the alphabet and of the first steps in reading, they made no progress; that grammatical forms were taught in the barren deductive way; that dreary memoriter work occupied a large portion of the school time.

On the other hand, the extensive use of colloquies gave a vitality to the subject which it has not possessed in later centuries. Declamations and orations as well as ordinary conversation made it a living speech and gave the student power through use. The Latin play, of either classic or contemporary origin, gave interest and facility in speech. Double translation and other methods brought in the use of the vernacular, secured valuable training in its use, assisted in giving it literary form, and ultimately resulted in giving it a place in the curriculum. Erasmus states the best contemporary view of method as follows:

“ But I must make my conviction clear that, whilst a knowledge of the rules of accidence and syntax is most necessary to every student, still they should be as few, as simple, and as carefully framed as possible. I have no patience with the stupidity of the average teacher of grammar who wastes precious years in hammering rules into children’s heads. For it is not by learning rules that we acquire the power of speaking a language, but by daily intercourse with those accustomed to express themselves with exactness and refinement, and by the copious reading of the best authors. . . . Some proficiency in expression being thus attained the student devotes his attention to the *content* of the ancient literature.

It is true, of course, that in reading an author for purposes of vocabulary and style the student cannot fail to gather something besides. But I have in my mind much more than this when I speak of studying 'content.' For I affirm that with slight qualification the whole of attainable knowledge lies inclosed within the literary monuments of ancient Greece. This great inheritance I will compare to a limpid spring of whose undefiled waters it behooves all who truly thirst to drink and be restored. . . .

"In reading the authors above mentioned for the purposes of vocabulary, ornament, and style, you can have no better guide than Lorenzo Valla. His *Elegantia* will show you what to look for and note down in your Latin reading. But do not merely echo his rules; make headings for yourself as well. Refer also to Donatus and Diomedes for syntax. Rules of prosody, and the rudiments of rhetoric, such as the method of direct statement, of proof, of ornament, of expansion, of transition, are important both for the intelligent study of authors and for composition. Such grounding in grammar and in style will enable you to note with precision such matters as these: an unusual word, archaisms, and innovations, ingenuity in handling material, distinction of style, historical or moral instances, proverbial expressions: the notebook being ready to hand to record them. Notes of this kind should not be jotted down at haphazard, but carefully devised so as to recall to the mind the pith of what is read."

Unfortunately the evidence goes to show that the schoolmasters did not have as clear an insight as did the great humanist, and that with them the means all too frequently became the end. The too common practice seems to have been that condemned in the second sentence of the above quotation.

THE VARIANT TYPE: THE REALISTIC SCHOOL.—The variant type was more commonly known as the academy, though the name "school for nobles" was also used. Various other local titles might be used, as Edelschulen, Furstenschulen, seminaries, pedagogia, Particularschulen, Modistenschulen.

Characterized by a broader and far more liberal curriculum, these schools attempted to prepare the children of the upper classes of society for the multiform duties of their stations. Rejecting the theory of the Latin grammar schools that a narrow linguistic discipline afforded a general training sufficient for all needs, they offered a study of the activities directly involved.

Consequently it is through this type of schools, less stable by far than the dominant type, that those variations have come which have permitted the development of educational ideas and practices. This type of education did not always crystallize into schools. In fact for a long period its adherents rejected the school and preferred the tutor or some other modification of the family relationship. But through this variable type, no matter what particular shape it took, came the introduction of the modern languages, the natural sciences, and the practical semi- or non-professional studies which would pertain to the life of a gentleman. Consequently through the same source there arose much that made for the betterment of method, for the broadening of the concept of education, and for the growing social significance of education.

Organization of the New Type of Education. — While this new conception of education produced the variety of schools indicated above, the more general attitude of the adherents of this "realistic" view was in favor of the tutorial system. In its earlier form this education was avowedly for the chosen few of the aristocratic class. Its aim was to produce men of the world, accomplished in those arts of government and management of practical affairs valuable to the gentry — those possessing wealth, entitled to the positions of influence in society, and controlling its institutions. It had little regard for the scholar, less for the pedant, little for schools, and none at all for schoolmasters.

The tutor, or a series of tutors, must possess these accomplishments and impart them to his pupils. Besides the tutorial

instruction in the home much was attained through attachment to courts of nobles or entourages of officials or landed gentry. Much more was accomplished through travel. The grand tour was a part of the education of every such favored youth. Thus were the modern languages acquired, as well as a knowledge of history, geography, the popular aspects of science and its practical applications. Agriculture, the art of fortification and of military affairs, some knowledge of government and of foreign relations, were presumed to be acquired. Extensive reading in the modern languages took the place of prolonged study of the classics. All this was to be accomplished through the tutor. When we recall that Vittorino, Æneas Sylvius, Ascham, Locke, Herbart, Froebel, were tutors and that a large number of others who wrote on education, as well as the prominent men of affairs throughout the centuries, were products of this type of education, its significance can be realized. In time, however, this educational procedure received a more definite institutional embodiment. The non-conformist academies of England and the real schools of Germany are the most important of these.

The English Academies.—In the middle of the sixteenth century Sir Humphrey Gilbert drew up plans for an Elizabethan Academy, for the instruction of the youth of the court and the gentry. Modern languages were to replace the classics; mathematics in all its practical application to navigation, surveying, and military affairs was given prominent place; government, management of estates, familiarity with public affairs, were to receive attention; the natural sciences were stressed.

A century later John Milton again sketched an academy in his *Tractate on Education*. The prodigious range of learning here advocated as essential was clearly beyond ordinary attainment, but it emphasized the limitations of the accepted type. De Foe in 1697 extended the scope of the idea, and advocated an academy for the education of women.

Meanwhile Milton's idea was attaining realization, though in a modest form. After the restoration of the Stuart monarchy (1661) nonconformists were excluded from English public schools and universities. This created a large body of students, not only desiring new institutions, but interested in a type of education that was a variant from the old. The Act of Uniformity (1662) drove nearly 2000 clergymen from their parishes. These furnished a ready supply of teachers. Further repressive laws made it necessary that such work of instruction as would bring these two classes together should be done furtively. Hence much of it was in the tutorial form. But from these conditions emerged a number of well-organized institutions termed academies. Their attendance was small, but their product was of high quality.

The number of these institutions which attained note was considerable, but in the nature of the case they could not be welded into a system. English educational thought and intellectual life was not ripe for them as a permanent type. While they flourished for a hundred years, the eighteenth century tended to reduce all to a dead level of orthodoxy and mediocrity. Yet they were able to pass on the torch of inspiration to America, and in England to keep the spark alive into the early nineteenth century with its educational awakening.

The German Realschulen. — The *Fürstenschulen* in several of the German states persisted through this period. In fact some still flourish in the form of agricultural schools, of value to the landed gentry. But with the dominance of French culture in the seventeenth and eighteenth centuries these so-called *Ritteracademien* became more and more artificial and exclusive, and with the decline of the French influence, the new type of German schools, either gymnasium or *real* school, took their place. The *real* school was the embodiment of this type of education for the great middle classes. In fact it originated in the attempt to adapt education to the lower

classes. The pietist Francke in the last decade of the seventeenth century founded a series of institutions centered about an orphan asylum in Halle. His effort was to give these orphan children an education of literary merit which at the same time would assist them in solving the practical problems in life. Industrial processes, printing, training in teaching, a practical interpretation of the sciences, and a rational use of the common branches were the chief means which he employed. The institution became the center of educational advance in Germany. In 1739 one of his pupils advocated a plan for the reorganization of a government school then under way, entitling the reformed institution "A Mathematical, Mechanical and Agricultural Real School." This is said to be the earliest use of this term. Another pupil, Hecker, in 1747, opened the first *real* school in Berlin in coördination with a German school and a Latin school. Its similarity to Franklin's plan, then in process of realization at Philadelphia, is very striking. Other schools of this type followed. For half a century, however, there was little difference between the programs of this type and those of the Latin gymnasia, except that a few realistic subjects were added. But in the early nineteenth century, with the strengthening of the classical studies and the requirement of Greek, the realistic subjects were minimized and the value of this type of education for the common people was greatly decreased. It was necessary that proper technical instruction or the basis for it be given in a special institution. Consequently the *real* schools with a more distinctive program multiplied.

It was not until after the middle of the nineteenth century that the *real* schools received full state recognition. By the Prussian regulations of 1859 the *real* schools of the first rank, requiring four years of Latin but no Greek, were accepted as state schools. Those of lower rank were dependent on the local communities. The demands of the industrial and commercial communities were not fully met until 1882 with the

Realgymnasium, the *Oberrealschule*, and the *Realschule*. Subsequent development is given in the following chapter.

The Influence on the Curriculum. — The very nature of this movement precluded any definite course of study. The point of view demanded a training in all those subjects which related to the life activities of the pupil.

The widest possible range of topics is suggested. Milton enumerates Latin, Greek, eloquence (rhetoric), religion, arithmetic, geometry, agriculture, geography (maps and globes), natural philosophy, physiology, astronomy, trigonometry, fortification, architecture, "engineering or navigation," physics, poetry and literature, moral philosophy, law and government, economics, politics, Italian, Hebrew, and possibly Chaldee, history, logic, and a great variety of physical exercises.

The actual program of an eighteenth-century English Academy included Latin, Greek, Hebrew, the Scriptures, logic, history, geography, philosophy (metaphysics), divinity, algebra, geometry.

Hecker's Berlin *Realschule*, later known as a *Pedagogium* and after 1797 as the Friedrich Wilhelm Gymnasium, contained in its program of studies, Latin, Greek, Hebrew, German, French, religion, drawing, geography, arithmetic, algebra, geometry, trigonometry, history, natural history (botany, mineralogy), physics, and philosophy.

Illustrative curricula could be multiplied indefinitely. But the principle underlying the curriculum in the views of these educators is evident; all the subjects then existing in an organized form were to be pursued. In the cases of the curricula given, the student body was a highly selected one, devoting at least nine years to the course outlined.

Locke, De Foe, and practically all the writers on education of this period who are not speaking from the point of view of the Latin schoolmaster emphasize a list quite as extensive. Obviously such a program is not intended for every child, but as Milton says only for those "who can draw the long bow."

Nor in every case were all of the subjects to be taken by every child favored with such an education. But in all cases it is the content subjects which are emphasized and especially those which have direct bearing on life. The organization of these into a school procedure was the result of a century more of experience.

Influence on Method. — Method was no better formulated than the course of study. But this very freedom gave it vitality and permitted development. Locke disposes of this question, as most of this group would, in a very summary manner. “ Learning may be had into the bargain, and that, as I think, at a very easy rate by methods that may be thought on.” The essential point of method was that knowledge was for use and learning was to be largely by practice. To quote Locke again, speaking of this tutorial type of education, “ This method of teaching children by a repeated practice, and the same action done over and over again, under the eye and direction of the tutor, till they have got the habit of doing it well, and not by relying on rules trusted to their memories, has so many advantages, which way soever we consider it, that I cannot but wonder (if ill customs could be wondered at in any thing) how it could possibly be so much neglected.”

Montaigne repeats this view in many forms. “ A boy should not so much memorize his lesson as practice it. Let him repeat it in his actions.” Perhaps the most famous phrasing of this view is his saying: “ To know by heart is not to know at all; it is simply to keep what one has committed to his memory. What a man knows directly, that will he dispose of without turning to his book or looking to his pattern.”

The tutor, usually unconscious of their philosophical basis, attempted to apply in an informal way the principles of learning formulated by Bacon and Locke. When schools of this type were organized, they attempted to do the same thing consciously. However, the teacher with little insight too frequently substituted an observation of natural phe-

nomena or a verbal familiarity with them for that knowledge which was demanded by the leader of thought. Comenius viewed educational method from this standpoint, though he was forced by circumstances to make his application chiefly to the study of Latin. The Philanthropinists, led by Basedow, made a more systematic attempt to reduce the new method to school procedure.

The leading educational reformers, Rousseau, Pestalozzi, Fellenberg, and Froebel, besides those previously mentioned, are exponents of some phase of this variant type of secondary education.

THE LATIN GRAMMAR SCHOOL IN THE AMERICAN COLONIES.—The Latin grammar school of Renaissance-Reformation Europe was transplanted bodily to the American colonies. In all but one of the thirteen colonies, that of Georgia, such schools were founded. The earliest schools in most of the colonies were of this type. The first attempt at a school in the thirteen colonies was assisted by a contribution from a shipload of merchants from the East Indies in 1621, and hence was named the East India School. The Virginia Company proposed a Latin grammar school, but the Indian subjects of the Company disposed otherwise, and the massacre of 1622 ended this attempt.

So far as extant records indicate, the first successful attempt, resulting in the grammar school at Boston in 1635, was of the Latin type. At least this school is the oldest permanent foundation. In the same year a Virginian settler by the name of Syms, following laudable English custom, left his estate in land and cattle to found a free school. But it was seven years before the grant was confirmed by the legislature. Subsequent records refer to the school as in operation, and it is claimed that some of this grant enters into the permanent funds of an existing institution. Several other bequests of this kind occurred in the southern colonies. Most of the resulting foundations were of an ephemeral character.

In Massachusetts, where also numerous bequests of this character were made, the gifts were used to supplement schools established by the towns. Consequently the foundations were of a far more substantial character. The most important of these private foundations was made by Edward Hopkins, a London merchant who in 1657 bequeathed his estate to found a system of such schools for Connecticut. Schools at Hartford, Hadley, and New Haven resulted. The Hopkins Grammar School of New Haven still flourishes.

In Massachusetts and Connecticut the towns built up such schools. The early records of many of these towns indicate a wonderful devotion on the part of these pioneers to the cause of higher education. The sacrifices which these frontier communities would make to maintain a Latin grammar school in the face of a desperate struggle with savages, famine, and hostile nature is indicated by the early town, court, and tax records.

The legislative records of the remaining colonies indicate a common belief in the necessity of at least one such school in each colony. In some of them, however, as in New York, the mixture of population and the dominance of commercial interests delayed the establishment of such an institution until well into the eighteenth century.

In several colonies, Massachusetts, Connecticut, New Hampshire, and Maryland, systems of such schools were set up. The unit area of the Maryland system and ultimately of that of Connecticut was the county. But the basis of the Massachusetts system, early copied by Connecticut and then by New Hampshire, was the town.

The eighteenth century records of these New England communities indicate that this type of school was ceasing to serve any broad educational need. The struggle of most of the communities to keep the schools going, the unwillingness of many to make the attempt, the dwindling attendance, all indicate a growing lack of adjustment between school and

actual social needs. By the end of the eighteenth century a new type of secondary school had arisen, replacing the Latin grammar school, which had all but disappeared. Those that still remained were but appanages to the colleges which had sprung up meanwhile in most of the colonies.

While the colonial legislative records have much to say concerning these schools, and there is considerable supplementary material relating to their organization, evidence relating to either curriculum or method is very scanty. Method is indicated chiefly by the textbooks. The *Latin Accidence* of Ezekiel Cheever shows no advance upon the European texts. There are entries in the Boston town records of the middle seventeenth century indicating an attempt to introduce Comenian methods.

The curriculum was even narrower than those of Europe, owing to the limiting circumstances of frontier life. To read and write Latin and possibly to speak it was the chief if not the sole aim. In instances the rudiments of Greek were added. During the eighteenth century, in the commercial centers, some mathematics for purposes of navigation and surveying was added. The requirements for admission to the colonial colleges do not indicate any wider preparatory training until after the Revolution. The broad scope proposed by Franklin for the University of Pennsylvania and its preparatory school and by Dr. William Smith for Kings College and its preparatory school do not seem to have had any permanent influence. The most frequent references in colonial records concerning the work of the grammar school relate to the extent to which such schools may do the work of the petty or elementary school.

However circumscribed their influence, these schools did accomplish their great purpose, announced in the early New England legislation, "that learning may not be buried in the graves of our forefathers in church and in commonwealth."

THE ACADEMY IN AMERICA. — The earliest proposed academy in America was that sketched by Benjamin Franklin in 1743. Six years later the school began operation. The educational ideas operative are clearly indicated by the following statements from Franklin's proposals:

“As to their studies, it would be well if they could be taught everything that is useful and everything that is ornamental. But art is long and their time is short. It is therefore proposed, that they learn those things that are likely to be most useful and most ornamental; regard being had to the several professions for which they are intended.”

The institution was organized in three schools, — Latin, Mathematical, and English. Soon after it grew into a college, the mathematical school was amalgamated with the new philosophical school, while the English school fell into comparative neglect. From the troublous time of the American Revolution the institution emerged as a university, with the English school still further subordinated. Against this subordination and neglect Franklin protested, but the academy had in this instance served its purpose.

Meanwhile the general force producing the academies was operative in America. Nonconformity, which worked to this end in England, served the same purpose in America, although the established church here assumed a varying form in different localities, and although the orthodox school — the Latin grammar school — had never attained the commanding position which it reached in all European countries. Through the Great Awakening, which affected the middle and southern colonies more than it did New England, numerous institutions of this type were instituted. The “Log College” which preceded Princeton, though never given the name of academy, was practically such a school. Many private institutions of this type, some of which assumed the name of academies, sprang up during the third quarter of the century. These

all had a meager and local support and most of them an ephemeral existence.

The institutions which gave standing to this new type of secondary schools were those founded by the Phillips family, the one at Andover, Massachusetts, in 1778, the other at Exeter, New Hampshire, in 1781. The purpose of these schools, as stated in the deed of gift of the earlier one, was "to lay the foundation of a public free school or academy for the purpose of instructing youth, not only in English and Latin grammar, writing, arithmetic, and those sciences wherein they are commonly taught; but more especially to learn them the great end and real business of living." Further on, "it is again declared, that the first and principal object of this Institution is the promotion of true piety and virtue; the second, instruction in the English, Latin, and Greek languages, together with writing, arithmetic, music, and the art of speaking; the third, practical geometry, logic, and geography; and the fourth, such other of the liberal arts and sciences or languages, as opportunity and ability may hereafter admit, and as the trustees shall direct."

During the early national period a number of the states faced with serious effort the problem of national education. Political views and practices were as yet aristocratic rather than democratic, and the educational ideas were the same. Consequently the efforts were directed chiefly towards the building up of a type of schools which would provide for the education of select youth of the better-to-do strata of society, giving them a broad education in a variety of subjects. Education for the masses was, for the most part, still in the form of pauper schooling.

During the last quarter of the eighteenth century and the first half of the nineteenth very many similar institutions were founded, initiated, and partially supported by private parties. Incorporation by act of legislature was given to numbers of these institutions in almost every state. In many states the

legislature granted financial support. Sometimes, as in Maryland, this was done by converting properties of earlier foundations to the uses of these new institutions; sometimes, as in Pennsylvania, by making direct grants from the state treasury; sometimes, as in New York, by the establishment of funds for the special benefit of this type of institution. In several of these commonwealths there was thus built up a genuine state system of secondary schools. Seldom did there exist any unity of plan or organization in these systems, and only in one case, that of New York, was there any adequate central control and supervision.

In the organization of the University of the State of New York in 1784 and 1787 these secondary institutions were made component parts of the university. Grants of fixed sums were early made and in 1813 a permanent fund, known as the Literature Fund, was established for their encouragement and support. Thus an effective control over expenditures and some supervision of subjects of instruction were maintained. So efficient was this system that its most flourishing period did not pass until the second or third decade after the Civil War. At times nearly 250 such institutions received aid from the state. In no other state was so extensive a system developed. And in none did such public systems postpone so long the development of the high school. In many states, especially the southern ones, private academies supplemented these public ones and postponed still further the rise of the high school.

The characteristic feature of organization in the academy was its private or quasi-public control. Neither state nor local community exercised any control, except as the state might require the teaching of certain subjects or the contribution of a certain amount from private sources before it would permit an institution to share in the distribution of general funds. Many of these institutions were merely private adventure schools. Many were supported or controlled or

supervised by religious denominations. The stronger ones were usually under the control of self-perpetuating bodies of trustees.

Many of the stronger academies developed into colleges and retained their original form of organization. In the majority of cases they died out with the development of a more popular form of education meeting the same needs. In some instances they grew into normal schools. The New York state system of normal schools had for the most part such an origin. In a substantial number of cases, academies developed directly into high schools. Thus the academies in Maryland contributed to the high school, as in New York they did to the normal school system.

While it is not possible to give any quantitative estimate of the extent of the academy system, it is evident that these schools existed in great numbers, and indeed were adequate to the needs of the population so far as the opportunity for education is concerned.

Curriculum and Method. — The characteristic educational feature of the academies was the breadth of the curriculum. As most of them depended for their chief support, even their very existence, upon large attendance and popular approval, they gave what people demanded. Consequently some were little more than advanced elementary schools and many, probably the great majority, included such subjects in their offering. The reaction against the Latin grammar school and the growth of democracy coincided with the rapid development of the modern sciences and the formulation of a great variety of new subjects of study. Many of the stronger of these institutions comprised two schools, the classical and the English. Even in the classical course of the Phillips Academies, geography, arithmetic, English grammar and declamation, algebra, and geometry were required early in the nineteenth century. Phillips Andover maintained for a time during the third decade of the century not only an Eng-

lish school, but also a department for the training of teachers. The natural sciences received much attention. This fact and the emphasis on the vernacular language and literature were the determining features. The extent to which the curriculum developed is indicated by the following list of subjects reported by institutions of this type to the Regents of the University of the State of New York in 1837: arithmetic, algebra, architecture, astronomy, botany, bookkeeping, Biblical antiquities, biography, chemistry, composition, conic sections, constitution of the United States, constitution of New York, elements of criticism, declamation, drawing, dialing, English grammar, evidences of Christianity, embroidery, civil engineering, extemporaneous speaking, French, geography, physical geography, geology, plane geometry, analytic geometry, Greek, Grecian antiquities, German, general history, history of the United States, history of New York, Hebrew, Italian, Latin, law (constitutional, select revised statutes, criminal and mercantile, Blackstone's Commentaries), logic, leveling, logarithms, vocal music, instrumental music, mapping, mensuration, mineralogy, mythology, natural history, navigation, nautical astronomy, natural theology, orthography, natural philosophy, moral philosophy, intellectual philosophy, penmanship, political economy, painting, perspective, physiology, English pronunciation, reading, rhetoric, Roman antiquities, stenography, statistics, surveying, Spanish, trigonometry, topography, technology, principles of teaching.

The gradual increase of the requirements for entrance to the American college during this period is an indication of the widening scope of the secondary curriculum. Arithmetic is the only subject besides Latin and Greek that was required before 1800, and that for only a few years preceding and in only a few cases. During the first half of the nineteenth century, English grammar, geography, algebra, geometry and ancient history were quite generally added. No doubt the fact that the academies were giving instruction along these

various lines was quite as much a reason for their appearance in the entrance requirements as the fact that the college authorities wished them as part of the preliminary preparation of students.

One other feature of the academy due to the broadening of the curriculum is worthy of particular mention. That is the admission of girls to the privileges of higher education. While this feature was not characteristic of the earliest academies, it became almost universal with the progress of the nineteenth century. In the first decades of the nineteenth century, in a few instances even earlier, many such schools were established for girls only. With the founding of Troy Seminary (1821) by Mrs. Willard and of Mt. Holyoke (1836) by Mary Lyon, a new standard was attained. The Troy school was probably the first institution for the higher education of women to receive government financial support. While the character of the work of these institutions was equal to that of most of the academies for boys, in very many, especially those under private control, the standard of attainment was low. Here the ideal of education as adornment prevailed. The following advertisement of one such school from the late eighteenth century is an extreme example of this type of education :

E. ARMSTON (or perhaps better known by the name of Gardner) continues the School at Point Pleasant, Norfolk Borough, where is a large and convenient House proper to accommodate young Ladies as Boarders; at which School is taught Petit Point in Flowers, Fruit, Landscapes, and Sculpture, Nun's Work, Embroidery in Silk, Gold, Silver, Pearls, or embossed, Shading of all Kinds, in the various Works in Vogue, Dresden Point Work, Lace Ditto, Catgut in different Modes, flourishing Muslin, after the newest Taste, and most elegant Pattern Waxwork in Figure, Fruit, or Flowers, Shell Ditto, or grotesque, Painting in Water Colours and Mezzotinto; also the Art of taking off Foliage, with several other Embellishments necessary for the Amusement of Persons of Fortune who have Taste. Specimens of the Subscriber's

Work may be seen at her House, as also of her Scholars; having taught several years in Norfolk, and elsewhere, to general Satisfaction. She flatters herself that those Gentlemen and Ladies who have hitherto employed her will grant their further Indulgence, as no Endeavours shall be wanting to complete what is above mentioned, with a first Attention to the Behaviour of those Ladies intrusted to her Care.

Reading will be her peculiar Care; Writing and Arithmetick will be taught by a Master properly qualified; and, if desired, will engage Proficients in Musick and Dancing.

In method also there was some development. At least these institutions broke away from the rigid and formal procedure of the Latin schools. They showed little aversion to innovation and they at least experimented with all the novel educational methods imported from Europe. Many of them adopted the Lancasterian monitorial plan of instruction. Somewhat later the Fellenberg scheme of manual labor had wide vogue. Pestalozzian methods were embodied in the new texts, and vitalized instruction. The natural sciences were taught through demonstration by the teacher with elaborate paraphernalia. Attainments in the vernacular were displayed through declamation, school exhibition, and public oration. The test of "use" was applied far more generally than the present-day public would tolerate. Even the education of accomplishments had this to be said in its favor,—the accomplishments had to be "shown off."

Much greater freedom was introduced not only in choice of subjects, but in method; and a closer correlation of studies with actual needs and experiences was attempted. The fact that a great proportion of academic students not passing on to college entered the teaching profession made for the use of the subjects studied in a more vital manner than had been previously attained.

THE AMERICAN HIGH SCHOOL.—As the Latin grammar school was the expression of European orthodoxy

and conservatism, and the academy of the dawning nationalism of America, as yet cast in aristocratic rather than democratic form, so the high school is the first full expression of American democracy in this phase of education. It was supported by taxation, with no tuition fees; it was controlled by public officials; it offered a wide course of study; it was articulated with the lower and the advanced phases of education.

Origin. — The origin of the term "high school" in the American significance is not clear. The term "higher school" in its European significance usually indicates all institutions above the elementary grade. It had been applied in a few instances to particular institutions, notably the Edinburgh High School. This Scottish institution, essentially an academy, employed the monitorial system of instruction and had achieved an international reputation. It is probable that this school gave its name to the American institution. The first institution of the new type to be founded in the states was opened in Boston in 1821 under the name of the English Classical School. It was avowedly a compliment to the Latin School of long standing, and was to provide an education in advance of the English grammar schools, recently developed as a continuation of the primary school for those boys who did not intend to proceed to college. The name "high school" was not applied in public documents until 1824. Meanwhile in New York City an educational leader, John Griscom, had been agitating for a high school. He had published in 1820 a work containing a description of the Edinburgh High School. In 1825 under his leadership an incorporated private institution was opened under the name of "Monitorial High School."

The general impetus which gave rise to the high schools worked through three distinct channels. One of these was the monitorial scheme of Lancaster and of Bell. This was a very popular plan for the establishment of free schools, adopted quite generally during the early decades of the nineteenth cen-

ture. The great merit claimed for the scheme was that it made free education for all possible by making it cheap. This was accomplished by having the older boys teach those less advanced. Lancaster argued that in this way one master could teach 1000 boys and claimed to have attained this ideal in his own experience. The first public school building erected in New York City in 1809 contained a room for 500 boys. In England Lancaster had "educated" boys by this plan at an annual cost per capita of \$1.25. The early public schools of New York City, as well as those of many other American communities, were on this plan. It was introduced also into many academies. With the development of the schools of the Free School Society of New York City, advanced grades were added, still taught by monitors. When the advanced grades were separated for the special purpose of training monitors, they became essentially a high school. This institution, however, did not thrive, and in New York City the form which the secondary school took was that of the Free Academy. Meanwhile, De Witt Clinton, the leading patron of the elementary system of monitorial schools in the city, was now governor, advocating the establishment of a system of monitorial high schools under state supervision and with both state and local public support. One was to be located in each county. But the academy system, with all of its local influences, was too strongly entrenched, and the general aversion to taxation for educational purposes was too strong, for the proposed scheme to materialize.

Nevertheless, the monitorial scheme, by demonstrating the possible cheapness of public education, led many communities to give assistance to private or incorporated academies when run on this plan and to develop the higher grades of the elementary school when based on public support. This tended to force the development of high schools, though the differentiation from the grades was slow.

A much more distinct origin of the high schools was through

the free academy. When the public contribution to academies became a more important factor in their support than the private contributions, or even than the tuition, the public began to demand a voice in the management of the institution and the removal of restrictions on its privileges. The former was occasionally secured through some right of appointment to the board of trustees, the latter usually by the removal of tuition requirements from students living in the area contributing by taxation. Numerous academies were thus transformed. The only step necessary to make these institutions high schools in the modern sense was to transfer their control to an elected board of trustees. This step was taken with the Free Academies such as developed in New York, Baltimore, Philadelphia, and other cities. These were high schools in all essentials. Later on they developed into City Colleges — though the reality was usually not attained until long after the name — or were merged into the city system under the one school board.

The most important force in the development of high schools, at least from the numerical viewpoint, though at the same time the least conspicuous, was the Union School District. During the late thirties and the two following decades — the so-called “Horace Mann Period” — the defects of the district school system had become conspicuous and the educational needs of the democratic population obvious. The effort to meet these needs, during this period or a little later, developed in almost every state a tendency toward the grouping of these small districts into larger units. This resulted in the union school. Naturally this unification took place first in the cities and towns. The advantages becoming obvious, villages demanded the same privilege. As this amalgamation proceeded a graded system developed which culminated in all larger units of population where the academy was not entrenched in a high school course full or rudimentary.

Development of the High School System. — The course of development through the union school may be illustrated in New York State. Beginning in 1837, there were numerous acts of the legislature giving union school systems to the smaller cities of the state. Most of these were free, several included a high school. In 1853 a statute was enacted giving the privilege of establishing such systems without special act. A few years later an amendment required all such schools to be free. The peculiar relations of the State Regents to the Superintendents of Common Schools in this state together with the dominant influence of the academies permitted no early or distinct development of the high school.

The state which most clearly shows the development of the high school is Massachusetts, as New York shows that of the academy. The basis of the development is found in the law of 1827, though the term "high school" did not come into general use until a decade or so later. The portion of the law which relates to secondary education is as follows:

" And every city, town, or district, containing five hundred families, or householders, shall be provided with such teacher or teachers for such term of time as shall be equivalent to twenty-four months, for one school in each year, and shall also be provided with a master of good morals, competent to instruct, in addition to the branches of learning aforesaid, the history of the United States, bookkeeping by single entry, geometry, surveying, and algebra; and shall employ such master to instruct a school, in such city, town, or district, for the benefits of all the inhabitants thereof, at least ten months in each year, exclusive of vacations, in such convenient place, or alternately at such places in such city, town, or district, as the said inhabitants, at their meeting in March, or April, annually, shall determine; and in every city, or town, containing four thousand inhabitants, such master shall be competent, in addition to all the foregoing branches,

to instruct the Latin and Greek languages, history, rhetoric, and logic."

This is essentially a union school; that is, a town school superposed on the district schools. It is not created by the union of old districts but is a revival of the old town school, now of a higher grade than the constituent district schools.

Two grades of high schools were defined in this law, the higher one distinguished by the addition of Latin, Greek, logic, and rhetoric to the curriculum. This law, with subsequent amendments, developed the first state system of high schools. Some of these amendments, especially that of 1840, were reactionary and lowered the standard. But by the Civil War period a comprehensive and effective system of high schools had been built up. In 1840 the term "high school" first appeared on the statute books. While there was no legal definition of the term, the following quotation or extract from the Annual Report of the General School Committee of Manchester in 1849 gives an excellent statement of the popular view.

"A high school is no ambiguous thing. It is a term that possesses an exact and well-defined meaning. It is neither a primary or a grammar school, nor a compound of the two, without any regard to age or attainment, but a school distinct by itself, to which there is no access, except through the two first. Thus high school has been defined for years past and this definition of them is recognized in our revised statutes (1835) and wherever schools are spoken of 'for the whole town,' as the saying is."

It has been frequently stated that there was no system of high schools in this country before the Civil War, and that no more than fifty or sixty scattered institutions existed. True it is that the use of the term was not yet general and the course of study not definitely fixed, yet by the standards we use to-day, as well as by those of the earlier period, these statements seem to be a gross underestimate. In his study of the written reports of the Massachusetts towns, Dr. Inglis gives the following summary :

CENSUS	REQUIRED BY LAW	ESTABLISHED ACCORDING TO LAW	PERCENTAGE MEETING THE LAW	ESTABLISHED BUT NOT REQUIRED	TOTAL ESTABLISHED
1830 . .	35	3	8.6	0	3
1840 . .	44	16	36.4	2	18
1850 . .	76	42	55.3	5	47
1860 . .	128	86	67.2	16	102

Meanwhile the establishment of academies had declined. During the decennium 1821-1830 there were three high schools and thirty-two academies established. During that from 1851 to 1860 there were sixty-five high schools established and nineteen academies incorporated.

The same forces were at work in other states during this period, commonly through a district union school law. The usual procedure was for a city to obtain through special enactment the privilege of establishing a union school comprising the higher grades. Then in the course of time the legislature would extend the privilege by general enactment. Thus the state of Ohio passed such a permissive law in 1848; Iowa in 1849; New York in 1853; Michigan in 1857. Unlike the Massachusetts plan, the compulsory feature was usually attained long after.

The right was often given to communities to maintain out of public funds schools whose benefits could be shared only by a privileged part of the community. Popular approval of the public high school came quite slowly in many regions. The courts upheld the right to establish such schools, the *locus situ* being the Kalamazoo case in the Michigan courts of 1874.¹

There were many minor steps in the building up of the high school system, some of which have not yet been taken in many commonwealths. The most important of these steps relate

¹ See Cubberley and Elliott, *Source Book in State School Administration*.

to the extension of the privilege of secondary education to every child. This is attempted through several schemes; by state payment of tuition, by free transportation, and by subsidizing poorer communities. The most significant of these movements is the very recent one of developing the rural high schools by a combination of all these means. The broadening of the curriculum and the improvement of method, together with this development of the rural high schools, have brought about the most striking feature in the present situation, namely, the great increase in the number of high schools and in their attendance. In the decade between 1900 and 1910 the attendance increased over 60 per cent. The most recent report of the United States Bureau of Education gives the number of high schools in the United States (1912-13) as 13,263 and the number of pupils attending as 1,246,827.

Next to this quantitative increase in importance, the changes in curriculum and method are the most significant. There was no essential difference in curriculum between the early high school and the academy contemporaneous with it. The chief distinction between these two types of secondary school lay in organization and form of support. Public maintenance tended to reduce the number of subjects offered and public control and responsibility tended to greater unity in the curriculum. But the high school made no great advance upon the academy. The Massachusetts law of 1827, previously quoted, gives the state curriculum. Many schools established under this law did not offer all of these subjects. Many offered others in addition. For example, the curriculum of the English High School of Boston in the year the law was enacted included fourteen subjects over and above those required. In smaller high schools the offering was naturally much more meager. But however the sections of the country or the institutions of the same section varied in their offering, the principles involved in the selection did not change. It was not until the last quarter of the century that educators

became conscious of the great problems involved in the selection and organization of proper curricula for secondary schools and in the elaboration of appropriate methods. And the new century had dawned before this consciousness spread to the public. The earlier realization found its expression in the *Report of the Committee of Ten* in 1893. The later expresses itself in the growing demand for a broadened and intensified curriculum, a vitalized method, and an organization which shall bring to every child the possibility of attaining those elements of culture essential to the proper use of life's leisure, and those practical elements essential to vocational and economic success.

The remainder of this volume is devoted to the statement of these problems and to the presentation of ways in which they have been or may be met.

PROBLEMS FOR FURTHER STUDY

1. What similarity is there between the situation in early Greek civilization and our own times, so far as the elements of the situation determine the problems of secondary education?
2. How far do we find in the theory of education as formulated by the Greek philosophers elements of the problem as stated by present-day writers?
3. To what extent is the relation between the practical and the theoretical types of schools in Greece the same that we have today?
4. To what extent did the grammatical and rhetorical training of Greek, Roman, or medieval schools meet their social needs?
5. Have these subjects the same educative value now as then?
6. Of what value to the modern secondary school teacher or administrator is Quintilian's treatise?
7. What were the chief Colloquies used as texts in the Latin grammar schools of the post-Renaissance period? What were their merits as texts? What principles of method were involved?
8. What was the value of the Latin play from the point of view of method? What was its educative value in other respects?
9. What were the merits and demerits of the study of Plautus and Terence? Of Cicero?

10. What were the chief characteristics of the extreme classicism called Ciceronianism? Make a study of the Ciceronian controversy.

11. In comparing the curricula of the Latin grammar schools of the sixteenth century with those of the classical schools of the early or middle nineteenth century and with those of the present time, what progress is to be found?

12. In the writings of the schoolmen of the sixteenth century, make a comparative study of curricula. Of method.

13. What were the limitations of the free schools of England, judged from the point of view of their actual service to contemporary society, or from that of modern times?

14. Make a comparative study of the various treatises on education during the Renaissance and the subsequent period, either of the dominant Latin school type or of the variant type, in regard to purpose, organization, method, of secondary education, or in regard to any one subject of the curriculum.

15. What points of value for modern school work are to be found in the Jesuit system regarding organization, method, discipline, curriculum?

16. Trace the development of any one subject in the secondary curriculum.

17. Trace the method of study used in any one subject.

18. What are the respective merits of private and public or of tutorial and school education?

19. Trace the development of the academies in any one state.

20. Trace the development of the high schools in any one state.

21. What historical factors are involved in the present high school situation in any one state?

REFERENCES

- ABELSON, PAUL. *Seven Liberal Arts*. New York, 1906.
- ADAMSON, JOHN WILLIAM. *Pioneers of Modern Education*. Cambridge, 1905.
- BOLTON, FREDERICK ELMER. *Secondary School System of Germany*. New York, 1900.
- BROWN, ELMER ELLSWORTH. *Making of our Middle Schools*. New York, 1903.
- Secondary Education*. Albany, 1900.
- FARRINGTON, FREDERIC ERNEST. *French Secondary Schools*. New York, 1910.
- FICK, R. *Auf Deutschlands Hohen Schulen*. Berlin, 1900.

- GRAVES, FRANK PIERREPONT. *History of Education*. 3 vols. New York, 1909.
- INGLIS, ALEXANDER JAMES. *Rise of the High School in Massachusetts*. New York, 1911.
- LEACH, ARTHUR FRANCIS. *Educational Charters and Documents*, 598 to 1909. Cambridge, 1911.
English Schools at the Reformation. Westminster, 1896.
- LEXIS, W. *Die Reform des höherer Schulwesens in Pruessen*. Berlin, 1904.
- MERTZ, GEORGE KARL. *Des Schulwesen der Deutschen Reformation im 16. Jahrhundert*. Heidelberg, 1902.
- MONROE, PAUL. *Textbook in the History of Education*. New York, 1906.
- MONTMORENCY, J. E. G. DE. *State Intervention in English Education*. Cambridge, 1902.
- PAULSEN, FRIEDRICH. *Geschichte des Gelehrten Unterrichts auf den Deutschen Schulen und Universitäten*. Leipzig, 1885.
German Education, Past and Present. New York, 1908.
- RUSSELL, JAMES EARL. *German Higher Schools*. New York, 1899.
- WATSON, FOSTER. *English Grammar Schools to 1660*. Cambridge, 1908.
- WOODWARD, WILLIAM HARRISON. *Desiderius Erasmus concerning the Aim and Method of Education*. Cambridge, 1904.
Studies in Education during the Age of the Renaissance, 1400-1600. Cambridge, 1906.
Vittorino da Feltre and other Humanist Educators. Cambridge, 1897.
- Cyclopedia of Education*. Free Schools, Endowed Schools, Grammar Schools, Colloquies, Latin Language and Literature, articles on various national systems and various academic subjects.
- See the bibliographies in the above books and those appended to the Cyclopedia articles mentioned above, and to the Cyclopedia articles on the various national systems.

CHAPTER III

SECONDARY EDUCATION IN EUROPE

FRANCE

POSITION OF SECONDARY EDUCATION ABROAD.

— Secondary education has never been adequately and acceptably defined. In the United States, we usually arrive at a working definition by a method of exclusion, segregating the field of elementary education at one end of the scale, and higher education, as represented by colleges and universities, at the other. The first deals with the absolutely essential educational processes, and the second with the purely cultural and professional aspects, while the loosely delimited intermediate area is commonly accepted as covering the field of secondary education. In England and on the continent, even this approximation is inadequate, for broadly speaking, the secondary school does not form a transition stage between the elementary school and the university. Although the secondary school is preparatory to the university, it is not necessarily, or even generally for the mass of the pupils, complementary to the lower school. It is distinctly a school for the classes, and not for the masses. For the major part of the pupils of the secondary schools, then, the three R's are taught either in elementary classes attached to these schools as in France and Germany, or in special detached schools as in England. In this last-named country, only a relatively small number of the secondary school pupils receive their grounding in the fundamentals in the regular elementary schools, and the great majority of these cases, aside from the scholarship holders, is found in the smaller towns and rural districts

where the educational facilities are naturally limited, and where the traditional class prejudice or caste feeling is perhaps less strong. In the last analysis, on the continent at least, it is the financial position of the parent that is the large determining factor in deciding whether the child shall go to a primary school or to a secondary school. Universal tuition fees in these foreign secondary schools operate to preserve the exclusiveness of this intellectual aristocracy. Appreciation of the social barrier between elementary and secondary schools is an absolute prerequisite to any discussion of the position of the secondary school abroad.

DEVELOPMENT OF THE SYSTEM OF SECONDARY SCHOOLS. — Of the four great civilized nations of the world, France has the oldest system of secondary schools, for the ancient Collège d'Harcourt, the first of a long line of illustrious institutions of secondary grade, was founded away back in 1180, thus even antedating the venerable University of Paris itself. In those early days, all schools were under clerical control, with the seven liberal arts still influencing the curriculum. Even at that time, the arts work of the university was given in the colleges, or secondary schools, a characteristic that still persists to a very marked degree in the secondary schools of to-day. The *Ratio studiorum* of the Jesuits (1599) embodied the most advanced pedagogical theory and practice of the time, and served as a model for the organization of the secondary school program of studies for nearly two centuries. Indeed its influence was indirectly felt almost to within the memory of men now alive, not only in France, but in Germany, England, and the United States as well. It represented the quintessence of humanistic culture, and embraced little outside classic and particularly Latin authors. The expulsion of the Jesuits from France, and the subsequent suppression of the order eliminated the form, but not the substance of Jesuit influence in the secondary school program of studies. Humanistic domination of the school program experienced but a

temporary reverse in the great social and political upheaval of the French Revolution. The succeeding "central schools" (1795-1802) which reflected the modern temper of the revolutionary governments exerted only a passing influence, but it was, nevertheless, a precursor of what the nineteenth century should bring to pass. With the tightening hold of Napoleon upon the political organization of the nation, the old order of things educational rose phoenix-like from the ashes of the blasted hopes of popular self-government. The present administrative organization of French secondary education dates from the Napoleonic reforms of 1802 and 1808, but the subject matter of the school curriculum throughout the nineteenth century was largely that of the old régime. In fact as late as 1821, a ministerial order required the instruction in philosophy to be given in Latin, and it was not until nine years later (1830) that the examination in philosophy for the bachelor's degree could be held in French. Such was the persistence of the humanistic tradition.

From the educational point of view, the nineteenth century in France was marked by the struggle of two sets of conflicting forces: humanism versus realism, and the church versus the state. Both of these began long before the beginning of the century, but during its closing years the strife became most acute. In each instance the newcomer won out, but only after a terrific contest. In the second, the state has absolutely vanquished its opponent, the passage of the law suppressing the teaching congregations (1904) and the abrogation of the Concordat (1905) marking the closing acts of what has proved a most dramatic struggle, and ending forever the domination of the church in matters educational. In the first instance, the old classical education has been forced to share its time-honored prerogatives with its younger rival, and realistic culture is officially at least on an exact equality with humanistic culture. The new program of 1902 established this parity.

THE SYSTEM. — Centralization of Control. — French education is noteworthy for the high degree of centralization that prevails throughout the system. This results in a standardization of administrative details of organization, of qualifications of teachers, and of program, but not of method. Most matters of control of secondary schools are regulated from the ministry in Paris, while the responsibility for seeing that these regulations are carried out devolves upon the rectors (one for each academy), and the academy inspectors (one for each department). Local or communal opinion enjoys practically no recognition on the purely professional side of secondary school administration. Such affairs are determined by the central educational authorities. The program of studies is drawn up, the syllabus of work is arranged, the qualifications of teachers are prescribed, the schools are inspected, and the leaving examinations are held by the central authorities, or their accredited representatives, the rectors and their deputies. Indeed, the control exercised by the educational department at Paris over the whole of France is as real as that exerted by any city school authorities in this country over the schools of their own municipality. Such a degree of centralization would be highly distasteful even in the most extreme of our American commonwealths, but it seems to succeed very satisfactorily in France. It is one of the legacies that Napoleon left to the French people.

Secondary Education is nowhere compulsory in France. — The citizens of a given community decide whether or not they care to assume responsibility for a school of secondary grade, which in every instance, whether or not it is a state school includes the construction, equipment, and maintenance of a suitable building, but after this everything else is determined for them automatically. Such centralization naturally has the defects of its merits. Undoubtedly it tends to strengthen the weaker schools, and theoretically at the same time to retard the most progressive. Unquestionably, it does prac-

tically eliminate individual experimentation and initiative in France, but the general standard is so high and the central control so uniformly sane that this repression is not seriously felt. Differentiation is recognized in the two general types of secondary schools.

Types of Schools. — According to the law of 1802, "every school established by the communes or conducted by private individuals wherein are taught French, Latin, the first principles of geography, of history, and of mathematics, will be considered as a secondary school." This sentence gives us the origin of the communal college. The *lycées*, devoting themselves primarily to Latin and mathematics, were supported from the public treasury, and so formed a class of institutions somewhat higher than the communal colleges. This old distinction persists to-day, and the nomenclature of a century ago is still retained. The *lycée* is a state school, while the college is a local institution. The outward distinction between the two resolves itself into a question of the source of the teachers' salaries. In the case of the *lycée*, the state provides this money, while in the case of the college, the community pays the bills. In any event the other expenses must be borne by the community. Nominally these two classes of schools are of equal rank, but practically the *lycée* is of a higher type. Nevertheless, the official program of studies is in each instance the same. The standards of the teaching force in the state schools are appreciably higher than in the colleges, so that the best teachers are naturally attracted there on account of the advantages of living in larger towns, the better salaries, and the increased social prestige attached to an appointment in a state school. Practically the difference between these two types of schools is quite comparable to that existing in this country between a metropolitan high school and a high school in a city of twenty thousand inhabitants.

Unrest in Secondary Education. — Within the past twenty-five years, probably no department of education has been

beset with more unrest and at the same time been the subject of more careful and systematic study than the field of secondary education. Germany took the initiative in the Conference of 1890 which bore fruit in the reform of 1892. This latter year saw the appointment of the Committee of Ten of the National Education Association of the United States, whose work is too well known to need further elaboration here. England followed suit two years later by appointing a Royal Commission under the chairmanship of Mr. James Bryce to make an exhaustive study of the condition of secondary education in that country. The voluminous report emanating from this body contained many recommendations that have since been incorporated into English law, the most important of them resulting in the present school organization under the control of the Board of Education (1900). The previous year saw France undertaking a similar piece of work through the medium of the Ribot Parliamentary Committee. Germany had another Conference at work in 1900, and this resulted in the new program of 1901. In the meantime, the French commission was gathering evidence from every source that seemed to promise any contribution to the solution of the vexed problem of secondary education. The result was the reorganization of secondary education in 1902. These various national inquiries and reforms followed so closely one after the other that international suggestion and initiative can scarcely have exerted much influence. They represent rather the outcropping of a common spirit of unrest, a feeling of dissatisfaction with the existing order. The investigations in England and France were productive of more significant educational changes than those in either Germany or the United States, those in the first-named country being more specifically confined to educational organization, and those in the second being fundamental reorganizations of programs of studies.

Primary and Secondary Schools Defined — All this paves the way for a more careful differentiation of the fields of

primary and secondary education than has thus far been vouchsafed. Although the terms "primary" and "secondary" are perfectly well known to every student of American education, the connotation attached to them in France is quite distinct from anything with which we are familiar. In the United States, the relationship between the two lower degrees of the educational scheme is a latitudinal relationship, with one system superimposed upon the other, whereas in France the two systems exist side by side, or rather there is a longitudinal relationship existing between them. In the United States, the youngster who goes to school at six or eight years of age enters an elementary or primary school. After completing the seven or eight years' course of the lower school, he passes on to a higher grade of school known as a secondary school. The lower school course is completed before he enters the higher school. The line of cleavage between the two types of schools is quite distinct and fixed, with relatively little overlapping. In France, on the other hand, the pupil who enters school at six years of age or younger may go to a primary school, or he may go to a secondary school. Both are state founded, state supported, state directed, and state inspected. The former is a free school; the latter is a fee school. For the first two years, the programs followed are substantially the same, differences of subject matter coming to light in the succeeding three years in the form of the modern language instruction that is found in the elementary classes of the secondary schools. The differentiation between the two types of schools is social, or speaking broadly, economic. Fundamentally, then, there is a sociological motive at work which determines whether the parent shall send his child to a primary or to a secondary school. The pupils of the secondary school look forward to a professional or directive career, while those in the elementary school can seldom rise above the position of non-commissioned officers in the great industrial, commercial, or agricultural army.

Characteristics of the Course. — The French program of 1902, which has since been modified in only minor details, presents certain unique features, among them, its flexibility, the opportunity afforded for the pupil to change from one course to another without serious loss of time, and the conscious effort to meet the leaving-school problem, made possible by the concentric-circle method of instruction. Election of parallel and equivalent courses, a novel feature in French programs, is definitely attributable to the influence of American education, but in France it has been worked out in a more satisfactory way than is ordinarily found in this country. French secondary education proper begins when the boy is about eleven years of age, although as has already been indicated, the preliminary training is generally obtained in the elementary classes attached to the same school. Up to the beginning of the secondary course, it is perfectly possible for the pupil to pass from the primary to the secondary school system practically at will, but once beyond this point it is next to impossible to make the transition.

In the terms of the official decree of 1902, "secondary instruction is given in a course of study which extends over seven years, and is divided into two cycles: one of four years, and one of three years." France thus distinguishes between a secondary school and secondary instruction, the former being applied to a class institution which receives the boy at the time when his schooling begins and prepares him to enter the university, and the latter referring to the instruction given during the last seven years of that period, normally from the eleventh to the eighteenth year.

At the moment when this secondary instruction begins, two parallel courses open out before the lad, one with Latin (division A), and the other without Latin (division B). Save for the exception just noted, the subjects of instruction in the two courses are the same, although the time devoted to Latin in division A is occupied by additional hours in French and

science in division B. The common subjects of instruction are French, modern languages (English or German), history and geography, mathematics, natural science, and drawing. Two years later, division A pupils may elect Greek, giving up two hours of modern language and drawing therefor. Another two years sees them at the end of the first cycle, four years from the starting point. This forms a natural break just about midway of the course and rounds out a complete though elementary circle of intellectual achievement. If the pupil is compelled to drop out here, he can do so without feeling that he is leaving a piece of work half done. He can carry away with him a definite unity of ideas. He has covered in cursory fashion the whole range of the national literature, paying considerable attention to the classic writers; he has studied from one to three foreign languages, according to the course he has selected, for from two to four or more years; he has completed elementary arithmetic, with perhaps some more advanced mathematics; he has been introduced to scientific lore; he has studied the geography of the whole world; he is familiar with the great movements of history from the very beginning down to 1889; and he has had two years of elementary moral instruction, introduced to supply the place of the former religious teaching; in other words, he has touched practically all the subjects of secondary school study. The advantage of this scheme over the old program of studies, which was laid out upon a seven-year basis, must be readily apparent.

At this point, an entire realignment is possible, for four parallel courses present themselves: section A, a strictly classical course, with both Latin and Greek; section B, a Latin-modern-language course; section C, a Latin-science course; and section D, a science-modern-language course. Two years later, the pupil must choose again, this time between philosophy and mathematics. In this highest form several of the subjects are relegated to the elective group,

while the major part of the time is devoted to philosophy, history, physical and natural sciences in the philosophy form, and in the parallel mathematics form to those same subjects together with mathematics and modern languages. In the latter class, nineteen hours per week are devoted to realistic subjects as against only about nine hours for the humanistic group. Reference to the complete program of studies which will be found on the following pages will clear up many questions with regard to the distribution of subjects.

It must not be forgotten that this does not represent the whole work of the French secondary school, for most of the important *lycées* have graduate courses on the letters or the science side, known respectively as "higher rhetoric" or "special mathematics," which train boys for the higher normal school or some one of the various engineering schools that are supported by the government. Entrance to these schools is entirely through competitive examination, and many of the foremost intellectual leaders of France during the last century have issued through their portals.

FRENCH SECONDARY SCHOOLS — BOYS

WEEKLY PROGRAM — REGULATIONS OF 1902-1912

I YEAR		Preparatory Division		II YEAR	
	HRS.				HRS.
French	9	French		French	9
Moral and civic instruction ¹		Moral and civic instruction ¹		Moral and civic instruction ¹	
Writing	2½	Modern languages		Modern languages	2
Simple history stories	1	Writing		Writing	2½
Geography	1½	Simple history stories		Simple history stories	1
Arithmetic	3	Geography		Geography	1½
Nature study	1	Arithmetic		Arithmetic	3
Drawing	1	Nature study		Nature study	1
Singing	1	Drawing		Drawing	1
		Singing		Singing	1
Total	20	Total		Total	20

¹ This instruction will be given in connection with the instruction in French, history, and geography, and is included in the time assigned to these subjects.

Elementary Division

(Eighth and seventh forms)

	Hrs.
French	7
Moral and civic instruction ¹	
Modern languages	2
Writing	1
History and geography	3
Arithmetic	4
Nature study	1
Drawing	1
Singing	<u>1</u>
Total	20

¹ This instruction will be given in connection with the instruction in French, history, and geography, and is included in the time assigned to these subjects.

First Cycle

(Length, four years; from the sixth to the third form inclusive)

DIVISION A

DIVISION B

Sixth Form

	Hrs.		Hrs.
French and Latin	10	French	6
Modern languages	5	Modern languages	5
History and geography	3	History and geography	3
Arithmetic	2	Arithmetic	3
Natural science	1	Natural science	2
Drawing	2	Drawing	2
		Writing	1
Total	<u>23</u>	Total	<u>23</u>

Fifth Form

	Hrs.		Hrs.
French and Latin	10	French	6
Modern languages	5	Modern languages	5
History and geography	3	History and geography	3
Arithmetic	2	Mathematics and mechanical drawing	4
Natural science	1	Natural science	1
Drawing	2	Drawing	2
		Writing	1
Total	<u>23</u>	Total	<u>22</u>

DIVISION A

DIVISION B

Fourth Form

	WITH GREEK, HRS.	WITHOUT GREEK, HRS.		HRS.
Literary instruction :			Literary instruction :	
Ethics, French, Latin	10	10	Ethics, French	6
Greek	3	—	Modern languages	4
Modern languages . . .	3	4	History and geography . .	3
History and geography	3	3	Mathematics, bookkeeping, and geometrical drawing .	4 $\frac{1}{2}$
Mathematics	2	2	Natural science	1
Natural science	1	1	Physics and chemistry . . .	1 $\frac{1}{2}$
Drawing	1	2	Drawing	2 $\frac{1}{2}$
Totals	23	22	Total	22

¹ One hour for mechanical drawing.

Third Form

	WITH GREEK, HRS.	WITHOUT GREEK, HRS.		HRS.
Literary instruction :			Literary instruction :	
Ethics, French, Latin	11	11	Ethics, French	7
Greek	3	—	Modern languages	5
Modern languages . . .	3	4	History and geography . . .	3
History and geography	3	3	Mathematics and geometri- cal drawing	4
Mathematical science .	3	3	Physics and chemistry . . .	2 $\frac{1}{2}$
Drawing	1	2	Natural science	1
			Bookkeeping ¹	—
			Drawing	2
Totals	24	23	Total	24 $\frac{1}{2}$

¹ One hour optional for practical bookkeeping in schools where its local usefulness is recognized by formal vote of the regular teaching staff in general assembly.

Second Cycle

(Length, three years; from the second to the philosophy-mathematics form inclusive)

Second Form

	SECTION A	SECTION B	SECTION C	SECTION D				
	Latin-Greek	Latin-Modern Languages	Latin-Science	Science-Modern Languages				
	Hrs.	Hrs.	Hrs.	Hrs.				
Literary instruction	{ French . . . 4 Latin . . . 4 Greek . . . 5	} 13	{ 4 } 8 4 } 8 -	{ 4 } 8 - -				
					History and geography	{ Modern history . . . 2 Ancient history . . . 1½	} 4½	{ 2 } 3 - } 3 1 }
Modern languages	2	1 ¹ } 7 4 ² }	2	1 ¹ } 7 4 ² }				
Mathematics	2	2	4½ ⁴	4½ ⁴				
Physics and chemistry	-	-	2½ ⁵	2½ ⁵				
Science laboratory	-	-	2	2				
Drawing	2	2	{ 2 } 4 ³ 2 }	{ 2 } 4 ³ 2 }				
					Totals	23½	23½	26

1 One hour in Sections B and D for the language studied in the first cycle.
 2 Four hours for the second language.
 3 Two hours for mechanical drawing.
 4 Mathematics instruction occupies five hours up to February 15th, and four hours after that date.
 5 Chemistry instruction occupies one hour up to February 15th, and two hours after that date.

First Form

	SECTION A	SECTION B	SECTION C	SECTION D
	Latin-Greek	Latin-Modern Languages	Latin-Science	Science-Modern Languages
	Hrs.	Hrs.	Hrs.	Hrs.
Literary instruction	{ French 4	4 } 7	4 } 7	4
	{ Latin 3			3
	{ Latin, extra hours 2	- 2*	-	-
	{ Greek 5	-	-	-
History and geography	{ Modern history 2	2 } 5	2 } 3	2
	{ Ancient history 2			2
	{ Geography 1	1	1	1 } 3
Modern languages	2	1 ¹ } 7	2	1 ¹ } 7
		4 ² }		4 ² }
Mathematics	2 + 2*	2 + 2*	5	5
Physics and chemistry	-	-	3	3
Science laboratory	-	-	2	2
Drawing	- 2*	- 2*	2	2
			2 } 4 ³	2 } 4 ³
Totals	23 + 4*	21 + 6*	26	28

* Optional.

¹ One hour in Sections B and D for the language studied in the first cycle.² Four hours for the second language.³ Two hours for mechanical drawing.

Philosophy and Mathematics Forms

	PHILOSOPHY		MATHEMATICS	
	Section A	Section B	Section A	Section B
	Hrs.	Hrs.	Hrs.	Hrs.
Philosophy	8½	8½	3	3
Greek-Latin	4*	—	—	—
Latin	—	2*	—	—
Modern languages	2*	{ 1 2 ¹	2	{ 1 2 ¹
History and geography . .	3½	3½	3½	3½
Mathematics	2*	2*	8	8 ²
Cosmography	½	½	—	—
Physics and chemistry . .	5	5	5	5
Natural science	2	2	2	2
Science laboratory	—	—	2	2
Drawing	2*	2*	1 ² + 2* ³	1 ² + 2* ³
Hygiene (12 lectures of one hour each ⁴)	—	—	—	—
Totals	19½ + 10*	22½ + 6*	26½ + 2*	27½ + 2*

* Optional.

¹ The pupils have the right to select for themselves the distribution of these two hours.

² Mechanical drawing.

³ Ornamental design is optional.

⁴ These lectures are included in the natural science instruction.

Baccalaureate Degree. — The natural culmination of the course at a French *lycée* or college is the baccalaureate. This is purely a degree of secondary education, consequently differing materially from our corresponding degree. It is not easy to evaluate the American and the French degrees on account of the lack of standardization notorious in this country. The French degree, however, stands for a very definite intellectual attainment, the degree from Lille, Poitiers, or Marseille being accounted as high as that from Paris. It represents a

measure of attainment which would probably be reached about midway of the course at the better American colleges. In France, the bachelor's degree is the sole passport to the university and so to all grades of higher education. Each academy has its own baccalaureate examination commission whose members are drawn from university and secondary ranks in substantially equal numbers. Thus the examination fulfils the double purpose of checking up the work of the schools and at the same time of determining the candidate's fitness to undertake university study. It cannot be denied that it is rather a serious ordeal, for the mortality is very great, something over 40 per cent of the candidates succeeding at the first part of the examination, and about 60 per cent at the second. At the same time, it must be recognized that the leaving-school problem is not so acute in the French secondary schools as it is in America. With us there is a considerable dropping out all along the line, while in France the very great majority complete the course, and the mortality is largely concentrated at the end at the time of the baccalaureate examination.

Reference has already been made to the two parts of the examination, which are separated by an academic year. There are two sessions in each part per year, one in July and the other in October. The candidate who fails in July may come up again the next fall. Taking these facts into consideration and remembering that the candidates at the second part one year are restricted to those who were successful at the previous session, it will appear that between 55 and 60 per cent of those who really come up for the examination finally secure the coveted honor. The total number of bachelors in 1910 was 7063, and in 1912 was 7264. Since 1902 there has been only one baccalaureate, the former degrees in letters and science being no longer granted. The certificate given for successful passage of the first part bears the mention Latin-Greek, Latin-modern-language, Latin-science,

or science-modern-language, but no one possesses any official advantage over any other. Success in the second or final part carries with it the baccalaureate degree, with the mention philosophy, or mathematics, the chief point to note being that there is only one degree. The value is the same for all, whether the holder intends to enter the arts faculty, the science faculty, the law school, the medical school, or an engineering school.

School Population. — In the year 1913 there were 111 *lycées* for boys and 236 communal colleges in France and Algeria, containing about 58,000 and 37,000 pupils, respectively. Few of the former are outside the capitals of the departments, while practically all the latter are in cities of less importance. In fact, with the exception of Paris, no city has both a *lycée* and a college. The number of the *lycées* as well as their population is increasing slowly from year to year, rather more rapidly, indeed, than the population of the country. In spite of the dispersion of the congregations and the suppression of the schools under control of the religious bodies, the successors of these schools under private control still contain nearly as many pupils as are to be found in the *lycées*. The graduates of these private schools, however, must pass the baccalaureate examination given by the state in order to enter the university or any of the higher state institutions of learning.

Boarding Schools. — One striking characteristic that differentiates the state secondary schools in France from those in any other country is the fact that they are boarding schools. This is another heritage from the Jesuit colleges, although, as a matter of fact, the general scheme far antedates the Jesuits themselves, for the original university colleges in France were all boarding schools. Of late years, this residential feature has evidently been falling into disfavor, for not only are the boarding pupils not keeping pace with the growth of the schools, but their numbers are actually decreasing. In 1885 there were 25,000 pupils living in the *lycées*,

while by 1908, this number had fallen to 17,000, and to-day they are probably fewer still. Boarding departments in the colleges show the same tendency, although the losses here have not been so striking. While boarding-school life has its advantages, one can readily understand why French parents should be less and less willing to subject their sons to the almost cloistral seclusion in the cold stone "barracks" of a city school. The more rural character of the college locations together with the opportunity of living a freer life is partly responsible for the fact that the depopulation of the residential departments of the colleges has not proceeded so rapidly as in the case of the *lycées*. In addition to the boarding pupils, one finds in each school half-boarders, supervised study pupils, and day pupils. The half-boarders are subjected to the same régime as the residential pupils, save that they have the evening meal and sleep at home. They may come to school as early as six or half-past six in the morning. The supervised day pupils do all their studying in the study halls of the school under the same supervision as the first two classes of pupils. The day pupils are at the school only for the regular class work.

Teaching Force. — The residential feature of French secondary schools necessitates an elaborate administrative organization to meet this special condition. Each *lycée* is in charge of a *proviseur* or headmaster, who is managing director as well as educational head of the institution. He is assisted by a censor whose official title is "censor of studies," but whose chief function is that of discipline master. The censor looks after attendance, transmits all reports from the class teachers to the headmaster, and is in general charge of the boys while they are within the school precincts. A third general administrative officer is the *économe*, or bursar, who is the business manager and financial agent of the school.

The brunt of the teaching burden is borne by the regular teaching force, *professeurs*, as well equipped a body of men on

the whole as is to be found in any secondary system in the world. This staff in the *lycées* is really of superior type, for only *agrégés* are appointed to these positions. The *agrégation* is a title, a kind of diploma, which not only stands for a high degree of scholarship, but also indicates that the holder is one of the ten or a dozen best men in his subject in France that year, as proved by the fact that he has come out toward the head of a list in a national competitive examination. There are eight orders of *agrégation*: philosophy, letters, grammar, history and geography, modern language, mathematics, physical science (physics and chemistry), and natural science, corresponding to the various departments of learning represented in the secondary school program of studies. Most of these terms are sufficiently self-explanatory to need no further comment. The work of the *agrégés* in letters and grammar is essentially the same, each one having to teach French, Latin, and, when necessary, Greek. In the main, the letters men receive appointments in the classes of the first cycle, and the grammar men in those of the second cycle,

These eight orders of *agrégés* delimit exactly the fields of the departmental teaching. Such a high degree of specialization is provided for and observed in the French *lycée* that it would be as unthinkable for the *agrégé* in history and geography to teach a class in elementary mathematics, as for the professor in chemistry in an American state university to take a first-grade class in the university practice school. It is largely by differentiating the various fields of instruction and in keeping them distinct that the French schools have been able to develop such an effective teaching staff. They are careful, however, not to run to too narrow specialization, for it is relatively rare that even an *agrégé* teaches but a single subject. This is only true in the case of philosophy and modern languages. A man is *agrégé* in English, or German, or Italian, or Spanish, and the like, and he must confine himself to his specialty. It is immaterial how many teachers there may be in the school,

one is never allowed to teach only Latin, or French, or history, or geography. The letters or grammar man must have French and Latin; the history man must teach history and geography; the physical science man, physics and chemistry; the natural science man, botany, zoölogy, and geology; and the mathematics man must handle mathematics as a whole, and not break it up arbitrarily into the smaller fields so familiar in the United States, arithmetic, algebra, geometry, trigonometry, and the like. In this way the French seem to have limited the field of the teacher's work to a small enough area to insure a mastery of the subject, and yet have avoided the other extreme of narrow specialization. All *agrégés* may fairly be assumed to have covered an elementary and secondary course of twelve years; to have spent from one to three or more years in advanced study beyond the secondary school course by way of preparation for the competitive examination for entrance to the higher normal school; and then to have studied for three years (four in the case of the science men) in a professional school before coming up for the *agrégation*. The quality of the men who have survived this ordeal, with its various hazards, failure to negotiate any one of which means disaster, cannot be gainsaid.

The regular teachers in the colleges do not measure up to this high standard, for they are required to hold nothing more than the master's degree, for which of course the element of competition is lacking. In both *lycées* and colleges some of the classes are intrusted to acting teachers, whose qualifications are somewhat inferior to those of the regular teachers in the corresponding positions. There are roughly rather more than five regular appointees to two acting teachers in the secondary schools as a whole. In addition to these two classes of teachers, there are instructors of the elementary classes as well as special teachers of drawing and gymnastics.

The aforementioned groups constitute the teaching force proper of the schools. Specialization in the French schools

again comes to the fore to the extent that the teachers do nothing but teach. They come to school to meet their classes, and the moment the lessons are over, their responsibility ceases. Supervision of study rooms and other work of a more or less police-like character are not among their duties. Special groups of people are employed for this exclusive purpose. Tutors (*répétiteurs*) are on duty all day long to look after the boys during recreations and meal times, and to supervise them during the study hours in rooms set apart for that purpose; while from dinner time at night until after breakfast the next morning, surveillants are constantly with the boys. Every moment that the boy is in school, he is under the personal charge of some regularly appointed officer. Not only do the residential pupils lead lives of perfect regularity, where the opportunity for wasting time is reduced to a minimum, but thanks to the supervision of their study periods they are able to attack their work intelligently and in the most telling fashion.

Salaries. — The question of teachers' salaries is so complicated as to make any generalization convey but an imperfect idea of the actual situation. Every order of teachers in the entire system, whether it be headmasters in Paris, or headmasters in the provinces, regular professors in either of these two areas, acting professors, professors of drawing, tutors, and the like, is divided into six classes. An appointment to any one of these orders means beginning in the lowest class with the assurance of rising regularly in accordance with a very definite scale of advancement. A new salary schedule went into effect in 1911-1912 which raised salaries all along the line about five hundred francs in each instance, but provided for the present incumbents reaching the new standard in five or six years. Under this revised scale, the salaries of regular professors in Paris range from 5500 to 9000 francs, with an additional 500 francs to each *agrégé*. The corresponding figures in the provincial *lycées* run from 3700 to 6700

francs. Headmasters are reckoned in the same category with the regular professors, but they receive from 2000 to 4000 francs additional for their services as directors. Taking everything into consideration, the highest salary it is possible for a Paris headmaster to receive is 13,000 francs (\$2700). As a matter of fact, the highest salary actually paid in Paris in 1910 was 11,000 francs. Even keeping in mind that the headmaster has no house rent to pay and receives certain allowances for light and heat, this income still falls far short of what men in corresponding positions in this country receive. When the different standards of living in the two countries are evaluated, however, the American headmaster's advantage begins to disappear, and when cognizance is taken of the social and academic standing of the two men, the relative position of the two as expressed in our first comparison becomes quite reversed. Security of tenure together with the assurance of a retiring pension makes the advantage in the case of the French headmaster even more pronounced. The situation of the regular professor is not quite so fortunate, for his salary is less than that of his headmaster, and he must provide his own living accommodations, but all things considered his lot is a happy one. Secure in his position beyond the reach of any political or other malignant influence, with certain though perhaps slow promotion before him, possessed of sufficient leisure to provide for his own spiritual and professional growth, confident in the assurance of a retiring pension awaiting him, and able to live comfortably within his means, the lot of a French secondary teacher is almost to be envied. His school duties are certainly not onerous. There is a regularly arranged schedule showing the amount of teaching required of each class of teacher. In Paris this varies from ten to sixteen hours per week in the secondary classes proper, while in the provinces it runs slightly higher. Two hours additional may be demanded of anybody, but for that extra remuneration is granted. Further supplementary hours are entirely at the discretion of

the teacher, but opportunities are not lacking to add to one's income in this way.

School Fees. — Attention has already been called to the fact that the secondary schools of France are all fee schools. Instruction in every kind of a primary school is free, but in all grades of secondary schools tuition is charged. This varies so widely that averages would tell only partial truths. The schools all over the country are carefully classified and the charges graded for each of the four categories of pupils in every form from the lowest to the highest. In Paris the fees for the beginning pupils of the infant class range from 90 francs per annum for the day pupils to 900 francs for the boarding pupils, while in the highest forms the corresponding figures run from 650 to 1650 francs. In the provincial *lycées* the fees range from 40 francs to 700 francs for the infant class, and from 320 to 1250 francs for the top form. The highest figure quoted here, 1650 francs (\$330), seems little enough for the total yearly expense, including board, room, tuition, and other fees, in the best secondary schools in France.

Budget. — In view of the amount of the school fees, it is not surprising that the expenses of the government are considerably more than the receipts. It is interesting to note, however, that the boarding department succeeds far better than the day pupils' department, the former contributing nearly 95 per cent of the boarding expense account, whereas the day pupils pay only a little more than half of what they cost the state. In 1903, the amount carried on the budget to make up the deficit in the day-pupil department was seven and a quarter millions of francs, as opposed to only one million in the case of the residential pupils. In 1910, the former figure had risen to 8,400,000 francs, while the latter had dropped to 584,000 francs. According to the budget of 1903, the total expense to the state for secondary education over and above what it received from fees and the like amounted to about

25,800,500 francs — two and a quarter millions of francs for girls' schools, eighteen and three quarters millions for boys' schools, and the balance for administration, central office charges, scholarships, and other allied expenses. From time to time, attempts have been made to abolish fees in secondary schools, but since under the present system secondary education is absorbing nearly 12 per cent of the entire budget of the education department in addition to the receipts from tuition fees, there is little probability of this happening in the immediate future.

EDUCATION OF GIRLS. — Until within a single generation, public secondary education for girls has not figured in French social life. The passage of the law providing for establishing secondary schools for girls at state expense was one of the most significant acts of the period from 1879 to 1882, which may fairly be called the French modern educational renaissance. In May, 1907, the twenty-fifth anniversary of the opening of the first *lycée* for girls was celebrated in Paris with fitting ceremonial. This whole movement for girls' education is distinctly modern in its character, and it has therefore been free from the incubus of tradition which has certainly more than once hampered the development of boys' schools. M. Gréard expressed this very suggestively when he said: "Boys' secondary instruction had its traditions. Girls' secondary education lent itself much more easily to novelties, being itself a novelty." This situation became apparent more than once during the parliamentary debates upon the bill providing for the creation of these girls' schools. In the first place, they are exclusively day schools, although municipal or individual initiative not infrequently conducts boarding departments in conjunction therewith. In the second place, the whole constitution of the program of studies reflects a decidedly "modern" educational point of view. This latter characteristic will be more evident in the consideration of the subjects of instruction.

Girls' secondary schools fall into three general categories: state *lycées*, communal colleges, and secondary courses established by local authorities with the moral and in some cases financial support of the state. These three categories represent steps in the evolution of individual institutions, for practically every new *lycée* created within the last few years has passed through these three stages, beginning as a secondary course, being transformed into a college, and thence into a *lycée*. The secondary courses hardly merit the name "schools," for they lack the organization that such a term implies, nor can they be looked upon as permanent foundations. The appellation "course" is sufficiently descriptive. They are ordinarily in charge of directresses, with a teaching force drawn from the staffs of the boys' *lycées* or colleges in the neighborhood. No fixed program of study is prescribed for them, although the government offers certain official recognition in granting a diploma for successful completion of the work. This course prepares specifically for the two lowest diplomas required for teaching in elementary schools and for admission to the girls' higher normal school at Sèvres.

In 1913 there were 52 *lycées* for girls, 81 colleges, and 50 secondary courses in France and Algeria. Six years before there were 49 *lycées*, 61 colleges, and 63 secondary courses. The number of *lycées* has probably about reached a state of equilibrium. Secondary courses have been steadily decreasing in number since 1887, due to the fact that they are ordinarily looked upon as temporary expedients, but the loss here has been more than balanced by the gain in the number of colleges. Despite the fact that the *lycées* are the least numerous, they are by far the largest, judged on the basis of school population. The total number of girls in these three types of schools is not far from 35,000 pupils.

Organization. — Girls' *lycées* and colleges bear the same relation to each other that prevails in the case of the corresponding boys' schools. They are organized much more

effectively than are the girls' secondary courses, although they are quite unlike the boys' schools. The course is arranged on a five-year basis, instead of seven as in the case of the boys. Preparatory training is provided in elementary classes attached to the school, but the pupils do not enter here until they are eight years of age. This defers admission to the secondary school proper until twelve, and allows the whole course to be completed by the time the girl has reached her seventeenth year. The regular five-year course is divided into two parts, one of three years and the other of two, with a sixth year, found in only a few of the more important *lycées*, which prepares specifically for the higher normal school for girls.

Program of Studies. — The subjects of instruction for the first part of the course include: (1) ethics; (2) French; (3) modern languages; (4) history; (5) geography; (6) mathematics; (7) natural history; (8) physics and chemistry; (9) domestic economy and hygiene; (10) sewing; (11) drawing; (12) singing; and (13) gymnastics. To these must be added in the second part of the course: (1) psychology; (2) ancient and modern foreign literatures; (3) cosmography; and (4) elements of common law.

The program in full appears on the following pages.

Perhaps the most striking characteristic about this secondary school program is the absence of the classical influence. Greek has never appeared as a subject of instruction in the girls' schools, but Latin has been buffeted about in a rather ruthless but interesting fashion. When the schools were first established, Latin figured as an optional subject of study, introduced largely out of deference to the prevailing humanistic influence in secondary school affairs. In 1897 it was abolished entirely, its cultural element being represented by the study of Latin and Greek literary masterpieces read in the vernacular. It has recently been restored as an optional subject in a few *lycées*, largely in order to prepare girls for the baccalaureate examination.

WEEKLY PROGRAM

ELEMENTARY CLASSES OF THE GIRLS' SECONDARY SCHOOLS

(Hours per week)

SUBJECTS	INFANT CLASS	I	II	III
	8-9 YRS.	9-10 YRS.	10-11 YRS.	11-12 YRS.
French	6½	6½	6½	6½
Modern languages	2½	2½	2½	2½
History	I	I	I	I
Geography	I	I	I	I
Arithmetic	—	2½	2½	2½
Nature study	—	½	½	½
Needlework	*	*	*	*
Drawing	*	*	*	*

* No definite amount of time specified.

GIRLS' SECONDARY SCHOOLS — FIRST, SECOND, AND THIRD YEARS

(Hours per week)

SUBJECTS	YEARS		
	I	II	III
Ethics	—	—	I
French language and literature	5	5	3½
Modern languages	3	3	3
History	2	2	2
Geography	I	I	I
Mathematics	2	2	2
Natural history	I	I	—
Physics and chemistry	—	—	2
Domestic economy and hygiene	—	—	12 lectures of one hour each
Sewing	2	2	2 } minimum
Drawing	2	2	2 } time for
Singing	I	I	I } each subject
Gymnastics	1½	1½	1½ } per year
Totals	20½	20½	21

FOURTH AND FIFTH YEARS

REQUIRED SUBJECTS	YEARS	
	IV	V
Ethics	1	—
Psychology applied to ethics and education . . .	—	2
French language and literature	3	2
Ancient literatures	1	—
Modern foreign literatures	—	1
Modern languages	3	3
History	2	2
Geography	1	1
Mathematics	$\frac{1}{2}$ *	$\frac{1}{2}$ *
Common law	—	$\frac{1}{2}$ *
Physics	$1\frac{1}{2}$	—
Physics and chemistry	—	2
Animal and vegetable anatomy and physiology, hygiene	1	1
Totals	14	15
OPTIONAL SUBJECTS		
Mathematics	2	2
Additional modern language	2	2
Sewing	2†	2†
Drawing	2†	2†
Singing	1†	1†
Gymnastics	$1\frac{1}{2}$ †	$1\frac{1}{2}$ †
Totals	$10\frac{1}{2}$	$10\frac{1}{2}$
Grand totals	$24\frac{1}{2}$	$25\frac{1}{2}$

* 1 hour for one semester.

† Minimum.

School Population. — The population of the girls' secondary schools represents a distinctly different cross section of society from that of the boys', and in the main attends school with a different purpose in view. For the boy, the secondary school is a cultural institution, but one that has a distinctly

professional bent. In other words, he goes there chiefly in order that he may thereby pass into the law school, the medical school, the arts or science faculty, or the government engineering schools, in nearly every case with a professional career in prospect. With the girls, however, a relatively small number has teaching or any other professional calling in mind. Much less do the pupils of these girls' schools look forward to entering the ranks of the industrial or commercial army. Consequently, one is not surprised to find that the majority of the girls in these secondary schools drop out at the end of the first part of the course, having continued thus far with a purely general cultural aim in view.

Academic Distinctions. — There are two academic rewards in girls' secondary schools: the certificate of secondary studies at the end of the third year; and the diploma (*diplôme de fin d'études*) at the end of the fifth year. These are awarded on passing set examinations at these times. The baccalaureate, which crowns the work of the boys' secondary course, is a state examination with which the teachers of the school have nothing to do. The leaving examinations at the girls' schools, on the other hand, are practically in the hands of the teachers of the schools themselves. One reason for this perhaps is that the possession of the certificate or the diploma of the girls' schools carries with it no particular privilege, not even opening the way to university study. To be sure, women are admitted to the university, but they must pass through the same portal as the men, namely, the baccalaureate. Although the girls' schools as a whole do not prepare for this degree, no special consideration is extended on that account. Girls are held to exactly the same standards as boys, and they must make up their short-comings as best they may on the outside, by private tutoring or otherwise.

Standards of Teachers. — In order to acquire the right to regular appointment to the teaching force of the girls' *lycées*, the young woman must complete the work in the secondary

school system itself, leave with the diploma at the end of the course, and then go on and secure the *agrégation* as in the case of the boys' schools. This, too, is taken normally at the conclusion of the course in the higher normal school, although the standard here is materially lower than at the corresponding boys' school. The requirements for regular appointment in the colleges and for appointment as acting teachers in the *lycées* are the same, namely, the possession of the certificate for teaching in secondary schools, which may be taken ordinarily at the close of the second year in the normal school. This examination is competitive like that for the *agrégation*, a fact that goes far toward assuring a high academic standard for the teaching staff.

Secondary education for girls is subject to tuition fees as is the boys', although it does not constitute such a drain upon the exchequer of the state. In fact some of the *lycées* are nearly if not quite self-supporting. Nevertheless the state is compelled annually to make a considerable appropriation for the support of these girls' schools. In 1910 the sum thus expended amounted to about three and a half million francs.

General Characteristics. — While the reform plan adopted in 1902 and the modifications since effected have not given universal satisfaction, the secondary school situation in France is probably more nearly in a state of equilibrium than in any one of the other four leading nations. Within the last generation the progress achieved has been little short of remarkable. To-day scarcely anybody is shut out from enjoying its privileges on account of lack of school facilities. It must be kept in mind, however, that the presence of fees in all secondary schools puts them beyond the reach of the great mass of the people, but this is deliberate on the part of the educational authorities. The United States is the only nation in the world which offers universal free secondary education. The older nations are organized on a decidedly aristocratic basis, and France, al-

though nominally a republic, is yet dominated by the old monarchical traditions. The fact that there are scholarships available for the brilliant children of the lower social classes counts for relatively little in affecting the truth of this assertion. France believes in giving everybody sufficient education to make him a useful and contented participant in the work of the world, but when it comes to training for leadership, she proceeds with the utmost caution, assuming that the great majority of the directing classes will be found among those who are financially comfortable. Any others must first prove their worth before she is willing to expend state funds for their education. From a pecuniary point of view alone, she is unalterably opposed to offering unlimited free education, primary, secondary, and higher to all, with the idea that qualified leaders will thereby be evolved. This same statement might with equal truth be made of Germany, and to a less extent of England as well. In France, however, once an individual has demonstrated the unusual character of his endowments, the state cannot do too much for him.

GERMANY

SOCIAL BACKGROUND. — Much of what has been said of the social background of the French secondary school system might well be repeated in the case of Germany with only here and there slight modifications, although outwardly the monarchical spirit is even more pronounced in Germany than in France. One point, however, needs to be made clear at the outset. As a factor in world politics, the empire presents a united front, but when one examines the situation more closely, it is evident that this unity is not rooted deep in the spiritual consciousness of the people. The foreigner does not usually differentiate among the inhabitants of Berlin, of Munich, and of Stuttgart, yet there is less similarity of temperament between the North German and the South

German than between the French and the Belgian, or the French and the Swiss of the Geneva district. In view of the extreme difficulty of finding anything that might be called a national type in Germany, the Prussian conditions are commonly taken as the standard. There is considerable justification for this from the fact that Prussia, with approximately three fourths of the area and the population, wields a preponderating influence in imperial affairs. Yet each state has its individual school system directed and controlled by its own educational authorities, exactly as in our own American states, and each state is entirely independent in its own domestic affairs. There is no imperial minister of education, nor does the imperial parliament attempt to impose any educational uniformity, save in exceptional instances, notably in the uniform standards demanded of all who propose to practice medicine, and in the general regulations prescribed for all who expect to secure the privilege of the one-year volunteer service in the army. In the absence of specific indications to the contrary, the following account may be assumed to describe conditions as they exist in Prussia.

EDUCATIONAL CONTROL. — As in the case of France, education is a matter of public concern that is looked at from a state point of view. Educational control in Prussia is centered in a minister of education, whose official title is Minister of Religious and Educational Affairs (*Minister der geistlichen und Unterrichts-Angelegenheiten*). As yet no German state has any cabinet officer who devotes his attention exclusively to educational affairs. Prussia seems tending in that direction, for in January, 1911, public health, which had formerly been a department of the above-named ministry, was raised to an independent position, and there is a growing demand for the separation of the departments of ecclesiastical affairs and education. There is one fundamental difference between the positions of the French and German educational heads: in France, the minister is responsible to the parlia-

ment, while in Prussia, the minister is responsible to the king alone. As a consequence, the incumbency of the German minister is considerably more stable than in the case of the corresponding French official. Below the minister is an under-secretary who acts as his deputy. The ministry is furthermore divided into three departments: one department for ecclesiastical affairs; and two for education, the first having charge of secondary and higher education, and the second of elementary education. There is also a council of some thirty members, mostly jurists, who aid the minister with their advice, and divide the various administrative duties that devolve upon so important a department. They have little or no final power, however, for the minister must assume responsibility for the entire conduct of his department. Whenever fundamental changes of great moment seemed desirable, he has been known to call a general conference made up of prominent laymen as well as of leading educators of the country to aid him further in his deliberations. This has happened three times within the last generation: in 1890, in 1900, and again in 1907. The first two resulted in the reforms of the boys' secondary schools of 1892 and 1901, and the last preceded the recent reorganization of girls' secondary education. It must be clearly understood, however, that no one of these conferences had any real power, not even the right to make recommendations for public consideration. They were merely deliberative bodies for the convenience of the minister, nor was he even morally bound to adopt their conclusions.

The Prussian state is composed of twelve provinces, each of which is administered by a president. All secondary and elementary educational affairs within each of these areas are under the control of the provincial school board (*Provincial Schulkollegium*), at whose head sits the above-mentioned president. The membership of these boards ranges in number from four in the smaller provinces to fourteen in

Brandenburg, the province in which Berlin is situated. All save the president are professional educators, who have toiled long and successfully in the educational service of the state, and who bring to their work the ripeness of judgment and sanity of mind that are so necessary in administrative work of this nature. While nominally inspection of schools forms a part of their duties, in practice they are chiefly occupied with the larger problems of administration in their position as intermediaries between the ministry at Berlin and the schools. They come into direct relations with the secondary schools of their province, being charged with the "supervision, direction, and inspection of schools which lead to the universities; and the appointment, promotion, discipline, suspension, and dismissal of teachers in these institutions" (except the directors). Thus these provincial school boards have practically the entire professional control of all secondary schools within their domains, save only for the examination of teachers. This is intrusted to another set of boards known as examining commissions (*Wissenschaftliche Prüfungs-Kommissionen*), eleven in number for the whole state. The advantages of the system will be at once apparent, for the examination commission of subject matter specialists (university professors are frequently members of these bodies) passes upon the candidate's academic qualifications, other experts judge of his teaching abilities, while the provincial school board renders the final decision as to whether or not the applicant should be placed upon the eligible list. In the face of this series of tests, it is next to impossible for the unworthy candidate to secure an appointment.

The provincial school board has direct charge of the royal schools (that is, those supported at state expense), while even in the case of similar schools founded and maintained by the municipalities the control of these boards is absolute over the purely professional side of the administration, and extends also in a supervisory capacity over the accounts, the budget,

and the general external administration. Although municipalities may establish schools of their own, they must in all cases conform to regulations laid down by these provincial school boards. So, too, with the selection of teachers. This is a prerogative of the communities, but inasmuch as their choice is limited to an eligible list drawn up by the provincial school board, they have little real power in the matter. The hand of the state is thus everywhere in evidence, but it is chiefly felt in the determination of standards — standards of health and hygiene, standards of salaries, standards of academic and professional fitness on the part of the teachers. It should be observed that these are all minimum standards and never maximum standards. If the community, for example, desires to pay more than the regular salary schedules (and in the cities of importance salaries in municipal schools are frequently higher than in the corresponding state schools), every encouragement is extended to such ambition. The municipal board may determine what kind of a school it shall have, nay is even left perfectly free to decide whether or not it shall have any secondary school at all; it may found the school, provide the equipment, choose the teachers under restrictions previously indicated, and do everything to put the school in running order. Once this is done, however, municipal prerogative ceases to be operative. The only thing left for the local board is to pay the bills, and it may not renounce this privilege at will, for it has absolutely no control over the purely professional aspects of the administration of its own school. This is all directed by the provincial boards. In this professional control by educational experts of the higher schools in Germany, one finds the clue to the marvelous efficiency of her secondary school system.

PRIMARY AND SECONDARY SCHOOLS. — The distinctions that we have already drawn between the secondary and elementary schools in France will, to a very large extent, hold true for Germany. In the last analysis, the fundamental

difference is a social difference. The stratification of the continental life has been carried to such an extent that the coming generation is reasonably sure to follow along in substantially the same social level as did the preceding generation. Any such rapid readjustments of social conditions as are constantly recurring here in the United States are relatively rare in the continental countries. Not that such changes are impossible, but the presumption is always against them. Furthermore, the conditions of industrial and commercial life are so highly organized that the youth is reluctant to run the risk of failure to "make good." The monarchical character of the German government, together with the relative venerableness of the German civilization and its consequent disinclination to change, tends to strengthen the stratification of the social conditions, and to increase the likelihood that the youth will not depart from the social groove of his father. If the father went to a higher school, the probability is good that the child will attend the same sort of a school. While the German parent is undoubtedly ambitious for his offspring, this ambition is not so unbridled as it is in this country. The boldness of the American parent in this respect would be characterized as rashness in Germany. In the United States, Huxley's familiar expression with reference to the educational ladder which should exist in every democracy with one end in the gutter and the other in the university is undoubtedly borne out by the facts in the case. It is possible for the humblest American youth to start at the very bottom and come out at the opposite end with no other assistance than his own unaided efforts. Such a course is impossible in Germany. No German state has a school system that permits any similar passage. On the other hand, as in France, each of the German states has two systems: the lower, or elementary, which is practically complete in itself; and the higher (or secondary, as we call it), which leads on to the university. Between these two there is only one regularly recognized

point of transition: at the close of the third or fourth school year. Once beyond here, it is next to impossible to transfer from the lower to the higher. Indeed one author has said that not one boy in ten thousand who completes the elementary school course ever reaches the *Gymnasium* or in fact any one of the "higher" schools.

This brings up the question: "What is a higher school?" A higher school is one whose leaving certificate carries with it the right to the one-year volunteer service privilege in the army. In the last analysis this is a prize reserved for the financially fit, for the tuition fees in the only schools that can grant this right effectually exclude the children of the proletariat from its enjoyment. It will be readily apparent that the ten per cent of free places in the secondary schools can have but little effect in alleviating this situation. Germany is so dominated by militarism that every able-bodied male looks upon his military service as a matter of course, and proceeds to make the best of it. The ordinary young man who comes up through the elementary school is conscripted for two or more years of service in the army. Graduates of higher schools may offer their services for a single year. During this time, in return for the honor, social position, and opportunities for further advancement, the volunteer relieves the government of all expense attendant upon his army service — food, lodging, arms, and equipment. To the American, this privilege would certainly seem of doubtful value, especially in view of the fact that it entails an expense of from three hundred and fifty to several thousand dollars per year, but to the German this sacrifice is well worth making. In the school that makes all this possible, the instruction goes beyond the simple elements given in the lower schools; it gives a complete liberal education; it leads on to the university, and to other higher institutions. Such a school must include in its curriculum: geography, history, German literature, mathematics, natural science, and at least two foreign languages.

BOYS' HIGHER SCHOOLS. — The category of boys' higher schools embraces the following:

Gymnasien and *Progymnasien*;
Realgymnasien and *Realprogymnasien*;
Oberrealschulen and *Realschulen*.

The first of each of these pairs of schools is a nine-year school, while the second is a six-year school, identical in all respects with the first two thirds of the course of its corresponding relative. On the completion of the courses of the *Progymnasien* and the *Realprogymnasien*, which are found only in smaller communities, the pupils ordinarily seek the respective full-course schools in the nearest large town. Thus the advantages of secondary education are extended to a much larger number of people without the expense of supporting so many nine-year schools. In each of these instances, the short-course school evolved from the full-course school. The contrary is true in the case of the *Oberrealschule* and the *Realschule*. Here the *Realschule* was the original type, which in its turn was expanded into the *Oberrealschule*.

Nine years is the minimum age for entering any of these higher schools, and the pupils must have already had at least a three years' course in the elementary subjects of reading, writing, arithmetic, and religion. Where the knowledge shall have been gained, however, is quite immaterial. It is offered in the first three or four years of the elementary school (*Volksschule*), as well as in the elementary classes (*Vorschule*) frequently found in connection with the secondary school.

Gymnasium. — The *Gymnasium* is a classical school pure and simple, with the study of the ancient languages forming a dominant feature of the course. French is the required modern language, although English appears as an elective, as does also Hebrew. Its specific purpose is to give such a broad humanistic culture as will prepare its pupils for subsequent university specialization along either arts or science

lines. The fact that nearly half of the 304 week hours in the whole course is devoted to linguistic subjects demonstrates conclusively the ultra-humanistic character of its work.

The detailed program follows :

GERMAN SECONDARY SCHOOLS

GYMNASIUM

	VI	V	IV	U III	O III	U II	O II	U I	O I	TOTAL
Required :										
Religion . . .	3	2	2	2	2	2	2	2	2	19
German . . .	4	3	3	2	2	3	3	3	3	26
Latin . . .	8	8	8	8	8	7	7	7	7	68
Greek . . .	—	—	—	6	6	6	6	6	6	36
French . . .	—	—	4	2	2	3	3	3	3	20
History . . .	—	—	2	2	2	2	3	3	3	17
Geography . . .	2	2	2	1	1	1	—	—	—	9
Arithmetic and mathematics	4	4	4	3	3	4	4	4	4	34
Natural science	2	2	2	2	2	2	2	2	2	18
Writing . . .	2	2	—	—	—	—	—	—	—	4
Drawing . . .	—	2	2	2	2	—	—	—	—	8
Gymnastics . . .	3	3	3	3	3	3	3	3	3	27
Singing ¹ . . .	2	2	2	2	2	2	2	2	2	18
	—	—	—	—	—	—	—	—	—	—
	30	30	34	35	35	35	35	35	35	304
Optional :										
Drawing . . .						2	2	2	2	
Hebrew . . .							2	2	2	
English . . .							2	2	2	

¹ From IV onward only for pupils with vocal ability.

Brackets indicate that the time for subjects enclosed may be redistributed if desired.

Realgymnasium. — The *Realgymnasium* likewise aims to give a general culture in which the classical spirit is represented by Latin, but in which the modern languages, mathematics, and the natural sciences figure largely. It represents a compromise between the ideals of the classicists and the ardent realists. This type of school was denominated a

hybrid by the Conference of 1890, and bade fair to go out of existence. The tide turned during the latter part of the following decade, and after the Conference of 1900 the *Realgymnasium* began to develop rapidly. In this course, Greek is replaced by English, while French and the sciences receive more attention than in the *Gymnasium*.

The detailed program follows :

GERMAN SECONDARY SCHOOLS

REALGYMNASIUM

	VI	V	IV	U III	O III	U II	O II	U I	O I	TOTAL
Required :										
Religion . . .	3	2	2	2	2	2	2	2	2	19
German . . .	4	3	3	3	3	3	3	3	3	28
Latin . . .	8	8	7	5	5	4	4	4	4	49
French . . .	—	—	5	4	4	4	4	4	4	29
English . . .	—	—	—	3	3	3	3	3	3	18
History . . .	—	—	2	2	2	2	3	3	3	17
Geography . .	2	2	2	2	2	1	—	—	—	11
Arithmetic and mathematics	4	4	4	5	5	5	5	5	5	42
Natural science	2	2	2	2	2	4	5	5	5	29
Writing . . .	2	2	—	—	—	—	—	—	—	4
Drawing . . .	—	2	2	2	2	2	2	2	2	16
Gymnastics . .	3	3	3	3	3	3	3	3	3	27
Singing ¹ . . .	2	2	2	2	2	2	2	2	2	18
	30	30	34	35	35	35	36	36	36	307
Optional :										
Geometrical drawing . . .						2	2	2	2	

¹ From IV onward only for pupils with vocal ability.

Brackets indicate that the time for subjects enclosed may be redistributed if desired.

Oberrealschule. — The *Realschule* is a six-year higher school which is outside the pale of any direct classical influence whatsoever, for no ancient language appears in its program of study. In many of these schools the course has

been extended for three years more, and we have the *Oberrealschule*, a school worthy to rank with the *Gymnasium* and the *Realgymnasium*. This is more particularly a fitting school for the present-day business life, in so far as the children of the upper classes are looking forward to that field of activity. Modern languages and the natural sciences, therefore, are the dominant elements in its program of study.

The detailed program follows :

GERMAN SECONDARY SCHOOLS

OBERREALSCHULE

	VI	V	IV	U III	O III	U II	O II	U I	O I	TOTAL
Required :										
Religion . .	3	2	2	2	2	2	2	2	2	19
German . .	5	4	4	3	3	3	4	4	4	34
French . .	6	6	6	6	6	5	4	4	4	47
English . .	—	—	—	5	4	4	4	4	4	25
History . .	—	—	3	2	2	2	3	3	3	18
Geography .	2	2	2	2	2	1	1	1	1	14
Arithmetic and mathematics	5	5	6	6	5	5	5	5	5	47
Natural science	2	2	2	2	4	6	6	6	6	36
Writing . .	2	2	2	—	—	—	—	—	—	6
Freehand drawing . .	—	2	2	2	2	2	2	2	2	16
Gymnastics .	3	3	3	3	3	3	3	3	3	27
Singing ¹ . .	2	2	2	2	2	2	2	2	2	18
	—	—	—	—	—	—	—	—	—	—
	30	30	34	35	35	35	36	36	36	307
Optional :										
Geometrical drawing .						2	2	2	2	

¹ From IV onward only for pupils with vocal ability.

Number of Schools. — On February 1, 1912, there were in Prussia 342 *Gymnasien*, 168 *Realgymnasien*, 102 *Oberrealschulen*, and 251 six-year schools, more than two thirds of which were *Realschulen*. Of the 236,173 pupils in these schools, nearly half, or, to be more accurate, 103,314, were in

the *Gymnasien*, 50,319 were in the *Realgymnasien*, 41,986 were in the *Oberrealschulen*, and the others were in the short-course schools. In 1911, with nearly the same total number of pupils, the graduates numbered 12,820, of whom 8692 had completed the course at the nine-year schools, and were consequently eligible to enter the university.

Fees. — Reference has already been made to the fact that there are no free secondary schools in Germany, although the fees are not high, especially considering the character of the instruction received. The maximum charges in Prussia are less than one half the corresponding tuition figures in France, amounting to 150 M. (\$37.50) in the three higher classes of the nine-year schools, to 130 M. (\$32.50) in the six lowest classes, as well as in all the classes of the *Progymnasien* and the *Realprogymnasien*. In the *Realschulen*, the charges are even lower still, 110 M. (\$22.50), unless the school is in connection with a nine-year school, in which case the 130 M. schedule is in force.

EARLY SPECIALIZATION DEFERRED. — Such an organization of secondary education as that in Germany, with the added consideration that passage from the elementary to any one of the higher schools was impossible beyond a certain point, long practically forced the youngster to decide at nine years of age personally or vicariously what his life work was to be. As late as 1900, only *Gymnasium* graduates were admitted to the university to prepare for law, medicine, or most of the teaching positions. Naturally the *Gymnasium* pupils on the whole selected that course because no other opened the way to a professional or government career. Finally the modern spirit that had been struggling for recognition in the field of secondary education for years beat down the guard of the conservative classicists, and the reform of 1901 in Prussia admitted the graduates of the three types of schools, *Gymnasien*, *Realgymnasien*, and *Oberrealschulen*, to practically equal privileges as far as university opportunity

and civil service preferment were concerned. Theology, however, still remains a monopoly of the purely classical school, and the study of medicine is reserved for those who have had at least the *Realgymnasium* course in Latin.

Reform Plan Schools. — Meanwhile a new type of secondary school had been created, known as the *Reform Gymnasium*, or Frankfort-plan school. This was an attempt to solve the premature specialization problem attendant upon compelling the early choice of the child's future career. Under the Frankfort system a single school has a *Gymnasium* and a *Realgymnasium* side. For three years there is no differentiation between them. Then the course bifurcates, one part pursuing the *Gymnasium* studies, and the other part the *Realgymnasium* studies. A comparison of the Frankfort program with that of the two pure types will bring significant differences to light. For example, Latin is not begun at all until the fourth year of the course, foreign language study in the meantime being represented by French. According to a recent reform of a few years ago, the fourth and fifth years under the Frankfort scheme have been made "almost common," the only differences in time allotment being confined to French and Latin. This practically makes it possible to change from one course to another with but slight difficulty as late as the end of the thirteenth year. At this point the *Gymnasium* pupils begin Greek and the *Realgymnasium* pupils begin English. Once beyond here any further change is impossible. Aside from deferring the final choice of course for several years, until the youth shall have gone far enough to make a correct decision more reasonably probable, this Frankfort scheme brings up an important pedagogical question as to the relative value of beginning the study of the classics comparatively late (at twelve instead of at nine) and pursuing them intensively, or beginning earlier and carrying them on more discursively. So far as information is available, the pupils at the reform *Gymnasium* do not seem to have

suffered any handicap even when they have later pursued their classical studies in the university.

In any event, the number of these schools is increasing rapidly, having grown in Prussia from fifty-seven in 1904 to one hundred and twenty-eight in 1912. If increase in numbers is any criterion, the Frankfort system has come to stay. Another type of reform institution which takes its name from Altona, the city of its birth, has attempted to do for the *Realgymnasium* and the *Realschule* what the Frankfort plan has for the other two types of higher schools. The Altona plan has been but moderately successful, for only six schools in Prussia followed it in 1912, and two of these had already decided to go over to the Frankfort scheme. These types of reform institution indicate in the first place that centralization of educational control does not necessarily mean permanency of form and structure, and in the second place that Germany is beginning to repudiate a narrow, fixed program of studies, and is turning toward the principle of election — not a hasty and more or less random choice of subjects of study, but a deliberate, intelligent selection of courses. Within a given course, however, there is substantially no election of subjects.

Although this reform plan has made marvelous progress during the past twenty years, the great majority of the schools still cling to the traditional forms. Germany, France, and the United States thus present three different types of solution for the dissatisfaction with secondary programs of study. In Germany, the pupil selects his school, *Gymnasium*, *Realgymnasium*, or *Oberrealschule* type. In France, he finds four courses in the same school — Latin-Greek, Latin-modern language, Latin-science, and science-modern language — from which to choose. In all of these instances, once the course is selected, the subjects of study are rather rigidly prescribed. In the United States, on the other hand, it is very difficult to suggest any general line of procedure, for the absence of

any accepted philosophical background for the organization of secondary education is all too painfully apparent. We certainly have carried the unlimited and more or less irrational election of subjects of study in our high schools to an extreme not paralleled in any of the other great nations. We may not agree with the principles controlling the organization of secondary education in Germany and France, but at least we must recognize the fact that there is some accepted educational philosophy back of it all, which is more than can be said in general for the conditions to be found in our own country.

EDUCATION OF GIRLS. TYPES OF SCHOOLS. —

Secondary education for girls in Germany suffers materially in comparison with that of boys. In fact, it has never been taken seriously until within the last few years. Much of the recognition accorded it to-day is due to the effective propaganda carried on by the "German Association for the Secondary Education of Girls" and other similar organizations which have been struggling so valiantly for the past thirty years. It may be unnecessary to observe in this connection that coeducation in secondary schools is practically unknown in Germany, although on rare occasions one finds girls attending boys' higher schools. Woman is not looked upon as an economic competitor of man in the work of the world, nor is she ever considered as belonging to the directing class. Since the program of studies in boys' schools is definitely planned for the preliminary training of the country's leaders, it will be readily patent that where opportunities for education of a more advanced type than that found in the elementary schools is offered to girls, it must necessarily differ widely from that provided for boys. Its aim is quite different; its organization is likewise quite different. In the main, it is based upon the course in the *Lyzeum*, ten years in length and extending from six to sixteen. The elementary work is an integral part of the whole school, thus resembling

the organization of the French secondary schools for boys, rather than the German. Superimposed upon the *Lyzeum* is the *Oberlyzeum*, with a bifurcated course, one branch, the Women's School (*Die Frauenschule*), with its combination housewifery and kindergarten training for two years, and the other, the Higher Training School, with a four-year course that prepares for teaching in a *Lyzeum*.

For those who look forward to university study (a privilege but recently extended to women in Germany) there is another type of school, *Studienanstalt*, entered from the *Lyzeum* at the end of the seventh or the eighth year of the course, the former if the pupil is to study classics, the latter if she wishes to go in for a purely modern grouping of subjects. These courses, six and five years respectively, correspond very closely to the *Gymnasium*, *Realgymnasium*, and *Oberrealschule* courses of the boys' schools. Completion of the assigned work in any of these three lines and passage of the leaving examination qualify for university entrance. Inasmuch as there are under three hundred (1911) public girls' higher schools, as the term has been used heretofore, in Prussia, and only about one tenth of them fit for the university (thirty in 1911), many girls who might desire a higher education are excluded from lack of preliminary training opportunity. One is moved to observe that nowhere else in the world is the young woman granted the facilities for secondary and higher learning that are to be found in America.

Reorganization of Girls' Schools. — The following diagram, including the minor changes in nomenclature to conform with the ministerial order of February 1, 1912, will throw considerable light on the organization of girls' schools. *Lyzeum* here replaces the late Higher Girls' School, while the former *Lyzeum* gives way to the name *Oberlyzeum*. A leaving examination (*Reiseprüfung*) has been introduced after the third year of the training school course, and the fourth or Practical Year of this course is henceforth to be known as the Seminar Class.

ORGANIZATION OF HIGHER GIRLS' SCHOOLS-1912.

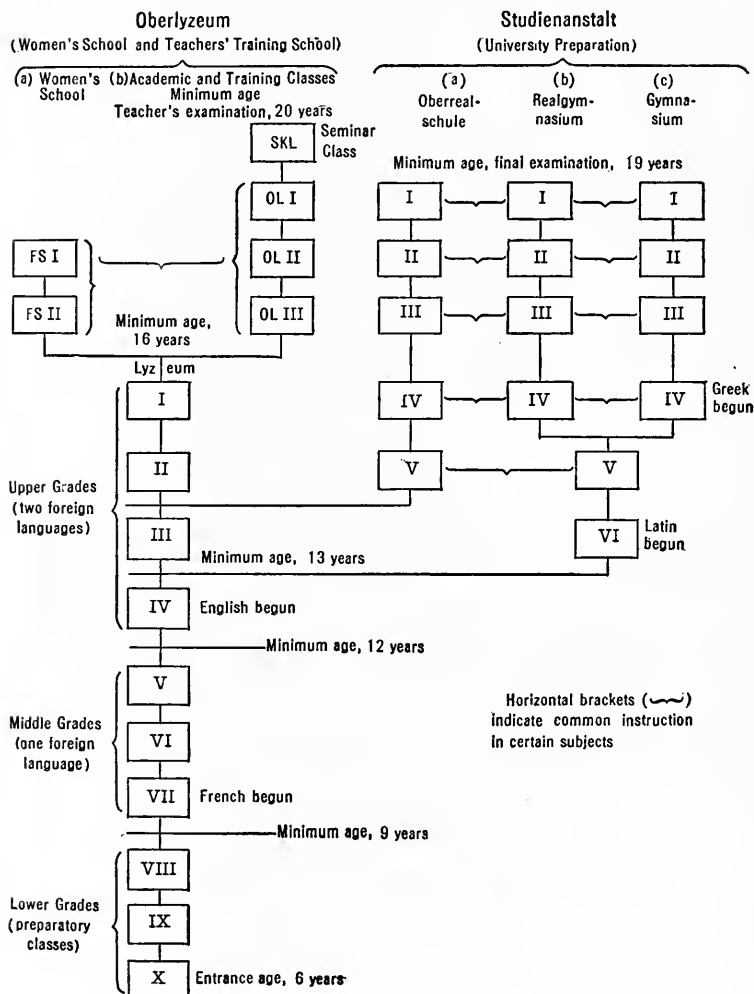

Program of Studies.— Appended will be found the detailed programs of the *Lyzeum* and both divisions of the *Oberlyzeum*. Those of the *Studienanstalt* resemble closely in general outline the programs of the corresponding boys' schools, save that the influence of the Frankfort reform plan is strongly in evidence. Latin on the *Gymnasium* side suffers most, but the loss in time here is compensated for by two years of compulsory English, and other hours distributed among French, geography, natural science, and drawing. The girls' complete course extends over thirteen years instead of twelve as in the case of the boys. This reduces the number of week hours slightly, the possible saving on account of optional work in singing and drawing making the difference even more noticeable in individual instances. As yet academic standards here are scarcely as high as in the corresponding boys' schools, but one could hardly expect it to be otherwise in view of the relatively recent admission of girls to university privileges.

PROGRAM OF STUDIES IN THE LYZEUM (GIRLS')

LITERARY AND SCIENTIFIC SUBJECTS

	LOWER GRADES			MIDDLE GRADES			UPPER GRADES				TOTAL
	X	IX	VIII	VII	VI	V	IV	III	II	I	
1 Religion	3	3	3	3	3	3	2	2	2	2	17
2 German	10	9	8	6	5	5	4	4	4	4	32
3 French	—	—	—	6	5	5	4	4	4	4	32
4 English	—	—	—	—	—	—	4	4	4	4	16
5 History and art history	—	—	—	—	2	2	2	2	2	3	13
6 Geography	—	—	2	2	2	2	2	2	2	2	14
7 Arithmetic and mathe- matics	3	3	3	3	3	3	3	3	3	3	21
8 Natural science . . .	—	—	—	2	2	2	3	3	3	2	17
	16	15	16	22	22	22	24	24	24	24	162

TECHNICAL SUBJECTS

9 Writing	-	3	2	1	1	1	-	-	-	-	3
10 Drawing	*	*	*	2	2	2	2	2	2	2	14
11 Needlework	-	2	2	2	2	2	†	†	†	†	6 (14)
12 Singing	2/2	2/2	2/2	2	2	2	2	2	2	2	14
13 Gymnastics	2/2	2/2	2/2	2	2	2	3	3	3	3	18
	2	7	6	9	9	9	7 (9)	7 (9)	7 (9)	7 (9)	55 (63)

* In classes X-VIII occasional drawing and clay modeling during the object lessons in German.

† Needlework is optional in the upper classes.

PROGRAM OF STUDIES OF THE OBERLYZEUM (GIRLS')

A. WOMEN'S SCHOOL (Frauenschool)

	II	I	TOTAL
1 Pedagogy	2	2	4
2 Household arts ¹	5	5	10 Including practice in cooking and household management.
3 Kindergarten teaching ¹	4	4	8 Including practice work.
4 Hygiene and care of children	4	4	8 Including practical work in crèches, day nurseries, and nursing.
5 Civics and economics	2	2	4 Including visits to philanthropic institutions and missions.
6 Household arithmetic (bookkeeping)	1	1	2
7 Needlework	2	2	4
8 Religion			Each subject according to circumstances and needs; two hours each per week.
9 German			
10 French, English, Latin, or Italian			
11 History, geography, natural science			
12 History of art			
13 Gymnastics			
14 Drawing and painting			
15 Music			

¹ Household arts and kindergarten teaching may be so arranged that in the first year only the former, and in the second only the latter, may be taken with 9 hours per week.

PROGRAM OF STUDIES OF THE OBERLYZEUM (GIRLS')

B. TEACHERS' TRAINING SCHOOL (Höheres Lehrerinnenseminar)

ACADEMIC SUBJECTS	ACADEMIC CLASSES				SEMINAR CLASS
	III	II	I	Total	
1 Religion	3	3	3	9	I ²
2 German	3	3	3	9	I ²
3 French	4	4	4	12	I ²
4 English	4	4	4	12	
5 History	2	2	2	6	I ²
6 Geography	2	1	1	4	
7 Mathematics	4	4	4	12	I ²
8 Natural science	2	3	3	8	I ³
9 Pedagogy	2	2	2	6	3
10 Method and model lessons	—	—	(4) ¹	—	4
11 Practice teaching	—	—	—	—	4-6
12 Reports and discussions . . .	—	—	—	—	8
Totals	26	26	26	78	26 (25-27)
TECHNICAL SUBJECTS					
13 Drawing	2	2	1	5	—
14 Singing	1	1	1	3	—
15 Gymnastics	3	3	3	9	3
Totals	6	6	5	17	3
Grand totals	32	32	31	95	29

¹ Method and model lessons in Class I are included in the periods given to each subject and are given in place of the respective subjects rather than as separate courses.

² Method and introduction to professional literature.

³ Method and introduction to experimentation.

TRAINING OF TEACHERS. — The training of teachers for the German secondary schools, together with the fact that only adequately prepared persons can secure appointment therein, constitutes one of the strong points of the

system. From principle, boys are taught exclusively by men, while girls are taught partly by men and partly by women. The former have almost invariably been trained at the university, while an ever increasing number of the women teachers are receiving the same university experience as the men, and the others are prepared in the training classes of the girls' schools mentioned before. Regular teachers (*Oberlehrer*) in boys' schools must have completed the course at a higher school, must have spent at least six semesters at a German university, and must have passed the state examination, which in itself occupies a full year of their time. Possession of the university degree is not required, nor in fact is it of any particular advantage to the man who intends to work in secondary schools. Once safely by the state examination, the candidate is assigned to a selected higher school for further professional work and some practice teaching during his seminar year. If successful here, he is advanced to his *Probefahr*, or year of trial teaching. Throughout these two years, the candidate is under constant strain, for in addition to an ever increasing amount of teaching, sporadic in the first year, but regular in the second year, he has his professional study to pursue, the teachers' meetings of his school to attend, papers and reports to prepare, as well as a more important dissertation to write toward the end of each year, embodying the results of his practical experience. Then only is he eligible for his teaching certificate. Even after that he has to await his turn for a specific appointment. The training of women teachers is not quite so strenuous, and the rapidly expanding opportunities for girls' education considerably increases the woman's chances of an early appointment. In any case the German teacher is prepared for his work through long years of training, and he receives his appointment only *after* he has proved his fitness for the position.

Salaries. — Salaries run about the same as those in France, and consequently seem remarkably low by comparison with

those paid in America, especially in view of the qualities demanded, the preparation required, and the responsibilities to be discharged. Headmasters of nine-year schools receive at the outset 5400 M. (6000 M. in Berlin), rising by regular stages to 7200 M. (\$1800) per year, together with lodging or a compensating allowance ranging from 900 M. to 1800 M. Headmasters of six-year schools start at 4800 M. and reach the same maximum, but only after twelve years of service as against nine and six respectively, in the two earlier cases. Regular teachers who have gone through the preparation previously described begin at 2700 M. (\$675) and reach the same maximum, but only after twenty-one years of service, profiting in the meantime by residence allowances varying from 560 M. to 1200 M. Special and other teachers, including those in the elementary classes, receive from 1800 M. to 4500 M., depending upon grade and length of service, together with similar residence allowances of from 290 M. to 720 M., according to the size of the community in which they live. Teachers in the girls' schools enjoy substantially the same salary schedules. Security of tenure, professional and social standing, and assurance of a retiring pension are factors which must be reckoned with in attempting to evaluate the income of the German secondary teacher.

ENGLAND

ENGLISH AND CONTINENTAL CONDITIONS CONTRASTED. — The problem of presenting a clear and accurate picture of secondary education conditions in England is immeasurably more difficult than in the case of either France or Germany. In the two latter countries, the whole scheme is logically organized, and responsibility can readily be determined. In England, on the contrary, the state has consistently refrained from taking any dominant part in educational organization or control until relatively recently.

As a matter of fact, there has really been a state elementary school system only since 1870, while the corresponding secondary system is practically the creation of the last dozen years. Before the assumption of state control, the forces of instruction were organized and administered by church, corporate, individual, or municipal authority. One writer offers a plausible explanation of the apparently confused state of this situation on the ground that: "The secondary school system of England is the expression of Saxon individuality and self-help." The Anglo-Saxon has carried his inherent love of freedom from control over into the educational world, and he has resented any and all government interference with his "vested" rights. Until relatively recently the Englishman has looked upon state attempts to control or to direct education as unwarranted usurpation of personal privileges. Fundamental conceptions of the right of the social whole to determine the character of the education of the individual with the attendant power of control, which have been in force in Germany since the *Allgemeine Landrecht* of 1794, and in France since the time of Napoleon, are not universally accepted principles in England. In view of these facts, one should not be surprised that the facilities ("system" is almost a misnomer) for secondary education in England in the past render extremely difficult all attempts at generalization. Even now there is no "system" of secondary education in England; there are various systems.

"PUBLIC" SCHOOLS AND PUBLIC LIFE.—For more than five hundred years, secondary education, at least that most worthy the name, was carried on in what are commonly known as the great public schools—schools which have done a work of incalculable importance in the development of the leaders of English thought and action—but schools which are far from being "public" in the ordinary acceptance of the word. Except for some of the earlier foundations in France and Germany, these are the oldest existing secondary schools

in the world, Winchester dating from 1382, Eton from 1440, St. Paul's from 1509, Westminster from 1560, Rugby from 1567, and Harrow from 1571, names which are to-day almost bywords throughout the Anglo-Saxon world. By 1660, this institution of great public schools may be said to have become established. All those mentioned above, as well as others of the more famous schools existing to-day, were all antecedent to that date, and they have been of immense influence in molding the traditions of English public life ever since. The oft-quoted remark, attributed to Wellington, that Waterloo was won on the playing fields of Eton, and Sir Maxwell Lyte's expression, "It is in her public schools and universities that the youth of England are, by a discipline which shallow judgments have sometimes attempted to undervalue, prepared for the duties of public life," represent something of the place these venerable institutions occupy in English public opinion. If one were to run over the long list of English public men for the past two centuries, there would be few whose names are not to be found on the rolls, and in many cases on the walls themselves, of the great public schools. All told there are probably forty or more of these public schools, but in practice this term is reserved for the nine great public schools, Winchester, Eton, Westminster, Charterhouse, Rugby, Harrow, Shrewsbury, St. Paul's, and Merchant Taylors'. These latter range in size from a few hundred up to the rather more than a thousand pupils that one finds at Eton, and account in all for upwards of five thousand boys. At most, then, this type of education is restricted to a very small portion of the total population, but these old schools have long served as a standard to which most of the other secondary schools strive to conform.

Nearly all these old schools owe their beginnings to the generosity of some individual founder, whose original modest endowment has in many cases grown to munificent proportions. Their management is intrusted to a self-perpetuating

board of governors, who appoint the headmaster and direct the financial affairs of the foundation. In other respects, the headmaster is entirely responsible for the conduct of the school, choosing (and until the passage of the Endowed Schools Act, dated August 1, 1908, dismissing) his assistant masters and other subordinates at will, determining the programs of study, and in general having free rein to develop the institution in accordance with his own standards. Such freedom offers immense opportunities for the really great man, especially when backed by the powerful inertia of centuries of tradition, and some of the headmasters have risen nobly to the occasion, as for instance in the striking cases of Arnold of Rugby and Thring of Uppingham.

In outward characteristics these schools are all very much alike, but when observed from within, each school has its own individual peculiarities, and each succeeds in stamping its influence on its boys to such a remarkable degree that when they come up to the university, the "initiated" can differentiate among Wykamists, Etonians, Rugbeians, Harrovians, and the like, as unerringly as the traveled American can distinguish among Yankees, Southrons, and middle westerners. Almost invariably these schools are boarding schools, with the boys scattered in groups of not more than forty among the houses of the assistant masters. Each house master is directly responsible for the boys living with him, physically, intellectually, and morally, so that the choice of a house is only little less important than the choice of a school.

Classical Influence. — With remarkable fidelity to tradition, these old public schools still conserve their classical courses, although one usually finds "modern, science, and engineering sides" listed in the school announcements. The classical course emphasizes Latin and Greek, with mathematics and French trailing along behind, while geography and modern history bring up a poor third. On the modern

side there is still a considerable amount of Latin, especially in the lower classes, but French and German occupy a large place, while the amount of mathematics, geography, and history is considerably greater than in the case of the classical course. Some schools maintain special Army Classes for prospective officers, but inasmuch as the differentiation of "sides" is found only in the upper forms, one cannot get away from the fact that the English public school boy is still brought up in a decidedly classical atmosphere. On whatever "side" he may be enrolled, he is sure to have his daily pabulum of Latin throughout the major part of his course, for with the public school headmasters Latin still forms the absolutely necessary foundation for all intellectual training, aside entirely from the fact that it is a required subject for university entrance and for most of the government examinations for which the boys are likely to be preparing.

Organization. — Theoretically there are six forms (as the classes are called), but the first is usually conspicuous by its absence, and one or two of the others are frequently missing, so that one runs across curious names for divisions and subdivisions of the forms in addition to the commonly found "upper" and "lower," such as: "remove," "remove and shell," "shell," and the "twenty." Boys enter at thirteen or fourteen years of age, and must leave at the latest by the time they are nineteen. On account of the desire to fix the impress of the school on the boy, most headmasters refuse to admit a boy after he is fifteen. Once in the school he is allowed to go through as quickly as his abilities will permit. There are three terms per year with examinations at the end of each, so that it is theoretically possible for the boy to pass through three classes per year, even without the double promotion that he sometimes receives. Thus the fellow who rushes along at top speed covering a couple of classes per year finds himself in the sixth form relatively young, and then he remains attached to this form until he is eighteen or nineteen,

since it is hardly advisable for him to enter the university before that time, even where university regulations permit. Meanwhile he is ripening and developing intellectually, for the masters see to it that he has plenty to do, and he has additional opportunity to prepare for scholarship competitions. From the foregoing, it is perfectly evident that grading and promotion are much less rigid than one finds in America. The amount of work expected of each class is not excessive, for the English public school master takes up his teaching as deliberately as he takes up his cricket or his billiards. Little is done under high pressure, but he aims to teach his boys the subject in question, as well as to develop them physically and morally.

Programs of Studies. — The following programs may give a little clearer notion of the nature of the work at two schools, Eton, and the Perse School, Cambridge. Neither one is typical of the public school programs as a whole, each merely indicating the work at its own particular school. In fact the "typical" public school program does not exist. Eton is one of the oldest and most famous of the public schools. The Perse School, although a very old foundation, may be called a present-day school dominated by a modern program with an extremely classical basis.

ETON

BLOCK	HOURS IN SCHOOL PER WEEK	DIVINITY	LATIN	GREEK	FRENCH	ENGLISH	MATHEMATICS	SCIENCE	EXTRA	DRAWING
A	22	I	15 ¹		—	2	—	—	4	—
B	24	I	6	5 ¹	4	4	4	—	—	—
C	25	I	7	5	4	4	4	—	—	—
D	25	I	7	6	3	2	3	3	—	—
E	25	I	11 OR 12		4	3 OR 2	4	2	—	—
F	25	I	7	4 $\frac{1}{2}$	3	3 $\frac{1}{2}$	5	—	—	I

¹ German may be substituted here for Greek.

At Eton there is a peculiar arrangement of classes whereby the school is divided into "blocks." Block A includes the sixth and part of the fifth form; block B, fifth form, upper division; block C, fifth form, middle division; block D, fifth form, lower division; block E, "remove"; block F, fourth and third forms. There is a special Army Class composed of boys looking forward to a military career, but there is no regular modern "side." Although geography and history do not figure in this schedule at all, the classical master contrives to find some time for them.

PERSE SCHOOL — CAMBRIDGE

FORM	ENGLISH COMPOSITION AND LITERATURE HISTORY AND GEOGRAPHY	FRENCH	LATIN	GERMAN ¹ AND GREEK	MATHEMATICS	SCIENCE	DRAWING	SINGING	DRILL
V	6	6	8	6	6	4	—	—	3
IV	6	6	8	6	6	4	—	—	3
III	11	6	6	—	6	6	I	—	3
II	13	6	6	—	6	3	I	I	3
I	15	9	—	—	6	4	I	I	3

¹ Boys from the IV form upwards may take German or Greek or both as their parents may deem most desirable.

Boys in the VI form specialize in classics, mathematics, history, modern languages, or science, and then time-tables are varied accordingly.

Sports are compulsory two afternoons per week.

Training for Leadership. — Athletic sports still occupy a very large place in the mind of the public school master as well as of the boy. Few printed programs contain any schedule for this time, but one can always count upon finding two or three afternoons per week occupied in this manner, and the exercise is as rigorously demanded of every boy in the school as any of his studies. At an English public school, every boy is an active and participating member of some cricket or football team, of some tennis or rowing club. He

is never allowed to take his athletics vicariously from the spectators' benches, or even in homœopathic doses. Such large emphasis upon sport has of late given rise to no little unfavorable criticism of the public schools, but it does develop bodily vigor, good temper, self-control, the ability to obey intelligently and to command. The average English public school boy will undoubtedly suffer considerably when compared intellectually with the graduate of the *Gymnasium* or the *lycée*, but neither one of these continental schools is making a deliberate effort to engender and develop any directive ability among its boys. Intellectual attainment is the large standard to which they strive to attain. It must be remembered, furthermore, that the *Gymnasium* and the *lycée* are both finishing schools, as far as a liberal education is concerned. Their graduates are at the threshold of their professional training. The English boy, on the other hand, has still at least a part of his university course to complete before his liberal education may be said to be ended. The American high-school boy develops a considerable degree of independence and initiative, but it is due to a certain *laissez-faire* system that seems to pervade a large part of the American life, private as well as institutional. There is no school system or school type in the world to-day that is offering the opportunity for discovering, and that is making the deliberate, organized effort to develop the capacity for leadership among all its membership that one finds in the English public school.

School Life. — Life at a public school is a rather expensive luxury. Tuition alone at one of the less famous schools must be reckoned at about £20 (\$100) per year, while at Eton the fees run up to £150 or £160 (\$750 or \$800). At a reasonable estimate one must count on spending about £300 (\$1500) per year for the privilege of keeping a boy at Eton. The fact that there are scholarships at all the schools does not by any means open these schools to the boys of really humble parents. The additional expenses that must be met in order

to keep a boy at a public school are such as to deter any but parents with relatively large incomes. The English public school is unquestionably a class school, with entrance thereto resting primarily upon a financial basis.

Characteristics of the Public Schools. — The English boy of the public-school type leaves home when he is nine or ten years old, remains three or four years at a preparatory school, from four to six years at a public school, and finishes up with three or four years at the university, throughout this whole period spending only the various holidays under the family roof. He associates entirely with those of his own sex; he is taught exclusively by men; in fact, throughout the long terms at school, the only direct feminine influence that comes into his life is the contact with the wife or the family of his house master. His is distinctly a masculine environment. It would be too much to suggest that this is responsible for the fine, manly, vigorous type of English public-school-university man, but it certainly is a contributing factor of considerable significance. Throughout it all, character building has stood for more than intellectual attainment. Not that the English system has not produced scholars, but its dominant purpose withal has been the development of strong, healthy boys, upright and noble, and with a highly skilled training in leadership. Herein lies one great difference between the English schools and the continental schools that we have been considering. Of course the system has its evils, but it has also developed its virtues.

PREPARATORY SCHOOLS. — Preparation for the public school is provided chiefly in a number of private-venture schools known as "preparatory schools." The English preparatory school thus differs widely from the American school of the same name. The former prepares for the English public school; the latter for the American college. The English preparatory school is not a secondary school at all. It obtains its pupils from dame schools, other private schools

of an elementary grade, or from private tutors, keeps them three or four years, and turns them over at the age of thirteen or fourteen to the public schools. These preparatory schools are likewise boarding schools which reproduce as nearly as they can the life and conditions of their successors.

OTHER TYPES OF SECONDARY SCHOOLS. — Close behind the nine great public schools follows another group of public schools, including Marlborough, Clifton, Uppingham, and the like, some of them schools upon very old foundations, others dating from the last half of the nineteenth century. They all imitate the great public schools more or less closely but, whether on account of their youth or otherwise, they have never succeeded in accumulating the mass of traditions and the illustrious rolls of their more famous fellows. On the basis of subjects taught, general organization, subservience to the requirements of the older universities and scholarship examinations, and dominance of the classical influence, only an imaginary differentiation exists between these schools and the great public schools.

Another representative type of the English secondary school appears in the great day schools like Dulwich and the Manchester, Bradford, and Bedford Grammar Schools. Although many of these are likewise foundation schools and are several times centenarians, the non-resident character of their school population has not been conducive to the accumulated tradition that centers around the boarding public schools. Nevertheless they are not handicapped by the narrow spirit of classicism that still dominates so much of the public school life, and they have thoroughly organized modern sides, with well-equipped laboratories, museums, and shops.

A fourth class of secondary schools is the ordinary grammar school, likewise on private foundation, but with a distinctly local following. These are largely imitators of the public schools, as far as aims and programs are concerned, save that they manage to have acquired most of the short-

comings and but few of the virtues of the older institutions. Their fees are lower; probably two thirds or more of their pupils are non-boarders; their courses are fully as classical as are those of the public schools; their equipment is usually most meager, with scanty facilities for science teaching, and with the modern language instruction largely inadequate.

Aside from a very numerous and probably worse than mediocre group of distinctly private-venture schools (estimated in 1898 to enroll 40 per cent of the boys, and 70 per cent of the girls attending a secondary school), this practically covered the opportunities for secondary education in England up to the reform act of 1902. Then for the first time secondary education became a national concern. It is true that various local authorities had provided scholarships in the existing secondary schools previous to that period, but in view of the fact that as late as 1900 the number of such scholarships in secondary schools held by former pupils, both boys and girls, of the public elementary schools was only between 5000 and 5500 for all England, the opportunities for any popular secondary education were relatively negligible. Such opportunities are still limited, but the progress registered since 1902 is really remarkable.

EFFECTS OF THE EDUCATION ACT OF 1899. — The education act of 1899 made an attempt to whip the various conflicting educational interests into line and to reduce the chaos to a semblance of order. Much indeed was accomplished at that time as well as by the supplementary legislation of 1902 and more recent years. All efforts point to a closer coördination between elementary and secondary schools, and the next legislation, as already outlined by the responsible authorities (1913), will undoubtedly make it more and more possible for the humblest child who has the requisite intellectual ability to finish his university course, and thus go far toward a complete democratization of English education.

In accordance with the act of 1899, a national board of

education was created in the spring of 1900, consisting of a president and various other members of the cabinet as co-adjutors. This has been facetiously called a "phantom" board, inasmuch as the full board never meets, the president alone constituting a quorum and therefore being empowered to determine and to order the policy of the board. As such this board has entire charge of public education in England and Wales, including within its powers practically all those that had previously been distributed among several educational and quasi-educational authorities. Below the president is a permanent secretary with rather large powers. Although the president is a member of the ministry with the natural uncertainty of tenure attendant thereupon, a measurable continuity of policy is assured through the office of the above-mentioned permanent secretary, but this is a guarantee by grace rather than by right, such as may be said to exist in the systems of France and Germany. The work of the central office is further supplemented by a force of inspectors for each branch of the service.

By the act of 1902, the old school boards were legislated out of existence, and county councils and county borough councils were made the sole authorities in matters of education other than elementary. Thus there were in England and Wales (July 31, 1911), London and forty-nine other administrative counties, as well as seventy-one county boroughs (towns of 50,000 inhabitants and upwards) whose councils exercise entire control over secondary education within their respective limits. In each case the practical direction is intrusted to an education committee of the larger body, but the ultimate financial control is vested in the full council. These local authorities are directed to consider the educational needs of their districts and take such steps as may seem advisable after consultation with the Board of Education, in order to "supply or aid in supply of education other than elementary." In some cases these various councils have

established secondary schools of their own; in some cases they have made grants to or awarded scholarships for schools already existing.

Submission to the control of the Board of Education by any secondary school, whether municipal, private, or endowed, is a thoroughly voluntary matter on the part of the governing body of the school in question. If it desires government aid or government recognition, it must conform to government requirements and submit to government inspection. Government recognition is extended to two types of schools: (1) those on the grant list; and (2) those recognized as "efficient" schools not on the grant list. The figures for England and Wales (1911-1912) were 995 for the former and 102 for the latter, enrolling (January 31, 1912) 166,081 and 18,975 pupils, respectively, 100,000 boys and 85,000 girls. Of the 885 secondary schools in England proper eligible for grants in 1911-1912, 381 were controlled by local authorities, 428 were endowed schools, and the remainder were administered by religious or philanthropic organizations. Among these schools falling within the jurisdiction of the Board of Education are representatives of all types of secondary schools save only the great public schools, which have thus far been too jealous of their time-honored freedom to submit to any semblance of control at the hands of the national educational authority.

SECONDARY SCHOOL DEFINED. — According to the regulations of the Board, a secondary school is one that "offers to each of its pupils an education of a wider scope and higher grade than that of an elementary school . . . in the subjects necessary to a good general education upon lines suitable for pupils of an average age-range at least as wide as from twelve to sixteen or seventeen." "A school will not be recognized as a secondary school unless (1) an adequate proportion of the pupils remain at least four years in the school, and (2) an adequate proportion of the pupils remain

in the school up to and beyond the age of sixteen." In rural districts and small towns, this may be changed to three years in place of four, and to fifteen instead of sixteen years of age.

REGULATIONS OF THE BOARD OF EDUCATION. — Aside from regulations with respect to building and equipment, approval of curriculum and time-table, length of school day and year, adequacy and competence of the teaching staff, permanency of salary,¹ reasonableness of fees, reports to the Board, opportunity for inspection, and various other details, the Board insists upon entire freedom from denominational tests, requirements as to religious observances or attendance upon religious exercises of the school as far as day pupils are concerned, and furthermore demands ordinarily that where tuition is charged,² 25 per cent of the places shall be open to qualified pupils from the public elementary schools without

¹ In view of the wide variability in teachers' salaries, it is almost futile to quote any figures. The average English assistant master's salary is said to be £120 (\$600) per year for non-resident teachers. When one finds a university graduate living at school beginning on as little as £15 (\$75) per year, the pitiful condition of some of these unfortunates reminds one of the days of Dotheboys' Hall. This same individual finally rose to £140, non-resident, after nine years of service. In comparison with this the London County Council scale of £150 (\$750), rising by £10 annual increments to £300 (\$1500), and in special cases to £350 (\$1750) appears positively munificent. Headmasters' salaries present a pleasing contrast, for in some of the endowed schools they run as high as £5000 (\$25,000), the ordinary average amounting to ten times that of the assistant masters. Even in municipally supported schools, the difference is considerable, though probably never reaching this figure. Compared with continental salaries, the English assistant master is very much underpaid, and the headmaster correspondingly overpaid.

² Of the 862 secondary schools in England on the grant list of the Board in 1910-1911, municipal as well as endowed, all but one charged fees for instruction ranging from "not over one guinea" (\$5.25) to "over twenty guineas" per year, the average for all schools amounting to between seven and eight guineas, with the figure of greatest frequency for the municipal schools falling between six and seven guineas, and the charges in the foundation and other schools averaging about two guineas higher. In forty-six out of forty-nine schools under Catholic auspices, the fees were not more than nine guineas per year, while in twenty-seven out of twenty-nine schools administered by the "Girls' Day School Trust," they were between seventeen and eighteen guineas.

fee. When all these conditions have been complied with and the instruction is otherwise satisfactory, the school is eligible to annual per capita grants from the Board, £2 (\$10) for each pupil between ten and twelve who has previously attended a public elementary school for two years, and £5 (\$25) for each pupil between twelve and eighteen years of age. Other extra or special grants are accorded for conformity to certain specific conditions. The total amount of such parliamentary grants for current expenses (England alone) under the caption "Secondary schools, preparatory classes, pupil-teachers, and bursars" for 1910-1911 (almost all of which was for secondary schools) amounted to £417,749, approximately two millions of dollars. This sum represents only about one quarter of the ordinary current expenses of those same schools.

OPPORTUNITIES FOR FREE EDUCATION. — On January 31, 1912, the 995 secondary schools in England and Wales on the grant list of the Board of Education enrolled 166,081 boys and girls, of whom 55,703, or 33 per cent, were former public elementary school pupils on the free list. The excess over the 25 per cent required by the Board is accounted for by the inclusion of a number of foundation or other scholarships offered by the governing bodies of endowed schools. This represents an enormous expansion of the opportunity for secondary education available for children of the working classes when compared with the situation before the passage of the act of 1902. In spite of the marvelous progress here noted, the opportunities for free education in secondary schools are not uniform the country over. In London there is one free place for every 70 children over five years of age in average attendance at the public elementary schools. Westmoreland offers the most favorable opportunities of all the English counties, the number of free places reaching as high as one in 48, while Oxfordshire falls at the other end of the list with only one for every 170 elementary school children.

Present Conditions. — Despite the efforts of the Board of Education to extend the secondary course by suggestion and regulation and to hold the pupils in school, the results are yet far from satisfactory. Pupils enter too young and leave too young. The age distribution is thoroughly surprising when one considers that the course of study is planned on the assumption of a 12 to 17 year age range, and an "efficient" school, according to the standard laid down by the Board of Education, is supposed to hold "an adequate proportion" of its pupils "up to and beyond the age of sixteen." For 885 schools in England on the grant list in 1911-1912, the sex and age distribution January 31, 1912, was as follows:

SECONDARY SCHOOLS — FULL-TIME PUPILS

CLASSIFIED ACCORDING TO AGE AT BEGINNING OF SCHOOL YEAR
1911-1912

	BOYS	GIRLS	TOTAL
1 Under 12 years of age	21,752	17,675	39,427
2 12 and under 16 years of age . .	54,833	43,790	98,623
3 16 and under 18 years of age . .	4,441	7,118	11,559
4 18 years of age and over	357	639	996
	81,383	69,222	150,605

Returns for the years 1908-1911 show that in schools on the Board's grant list, the average school life after the age of twelve of all boys who left during that period was only two years and eight months, while for girls under the same conditions it was one month longer, the average age at leaving school being fifteen years and seven months, and sixteen years, respectively. More efforts are evidently being made to lower the age for scholarship eligibility than to retain the pupils in school until a later age, considerable pressure being brought to bear upon the Board to pay grants on all pupils

between ten and twelve years of age instead of restricting the basis to the former elementary pupils alone. Economic conditions in general, the recent industrial prosperity that England has enjoyed, and the large demand for cheap clerical labor that young people of a yet tender age can perform satisfactorily make it extremely difficult for the greater part of the secondary schools over which the Board has jurisdiction to hold their pupils beyond the age of fourteen or fifteen years. They leave almost in mid-course, just at the time when the instruction ought to be of greatest value to them.

PROGRAM OF STUDIES. — It would be more difficult to select a type program for the grant schools or even for those under municipal control than in the case of the public schools, for the headmaster is given almost unlimited power in the matter, the Board contenting itself with very general requirements. In accordance with the provisions of the code, the subjects of the program of studies are as follows: English language and literature, with at least one other language than English. Special permission, however, may be obtained to omit the foreign language if the English provides "adequate linguistic and literary training." This rather vague expression is not defined, and it is left for the Board, or in practice for its inspectors, to determine. Geography, history, mathematics, science, and drawing must also appear in the program, together with provision for "organized games, physical exercises, manual instruction, and singing." Girls' schools further offer "practical instruction in domestic subjects, such as needlework, cookery, laundrywork, housekeeping, and household hygiene; and an approved course in a combination of these subjects may for girls over fifteen years of age be substituted partially or wholly for science and for mathematics, other than arithmetic." If there are two languages aside from English, the Board must be satisfied that the omission of Latin, if such be done, is for the educational advantage of the school.

Relatively little advantage has been taken of the possibility of omitting Latin, for it still appears (1912) on the programs of 85 per cent of the schools on the grant list. One must not infer that this proportion of all the pupils in these schools is studying Latin, but merely that the subject is found somewhere in the course of that relative number of schools. Two decades ago, the emphasis of the education authorities was largely in the direction of encouraging science study; later literary instruction came to the fore, with the teaching of English occupying the center of attention as far as schools that end at the sixteenth year were concerned; to-day adaptation to local needs and specialization seem to have monopolized the interest. "The school course may, under the elastic provisions of the Board's regulations, be given a certain bias throughout. Thus in a rural school instruction in all or nearly all the subjects taken may have regard to the agricultural or other rural occupations which the majority of the pupils may be expected to take up; the branches of physical science taught may be so chosen and dealt with as to be brought into clear connection with their application to such occupations; arithmetic and geometry may be applied in practice to such matters as keeping of accounts and land surveying, and even the instruction in English subjects and in modern languages may keep the same object in view." Furthermore, the "Board are prepared to approve suitable schemes for specialization of higher work in classics, in mathematics and physical science, in modern languages, taken in connection with history or economics, in art, and as regards girls in the important group of subjects included within the general term of housecraft, such as cookery, laundrywork, housekeeping, and household hygiene, dress-making, and the care of the sick or of babies and young children." In any event, this specialization can only take place after a good general foundation has been laid, facilities for such teaching must be adequate, and it may in no case trench

upon the "proper sphere of the technical school or other institution of specialized instruction."

Only by such indirect means as suggestions of this nature are the English central educational authorities able to bring about changes in the programs of the schools. The Board is willing to approve programs of studies showing certain characteristics; approval of programs, other conditions being met, means eligibility for grants; and this ultimately means financial support and government backing. Thus is the English system of secondary education growing and developing. As a system it is still far behind that in France or in Germany, but it is yet young; its opportunities are stretching out before; it has already discarded the old scheme of payment by results; and although the ancient system of tuition fees still prevails even in municipally supported schools, the increasing number of scholarships available for public elementary school pupils and the attention being devoted to this subject by the present Board lead one to hope that the time is not far distant when every child of proved intellectual ability, whatever the financial condition of his family, may find his educational opportunities limited only by his own ambitions.

COMPARATIVE FIGURES FOR SECONDARY SCHOOL POPULATION. — It may be interesting to append comparative statistics showing the secondary school population of the three countries just considered, together with that of the United States. One must be warned, however, that these figures are not altogether parallel, the age limits differing materially (England approximately 11 to 18; France, 6 to 18; Prussia, 9 to 18; and the United States, 14 to 18 years), and the nomenclature employed following the usage of the country in question.

SECONDARY SCHOOL POPULATION

COUNTRY	POPULATION	SECONDARY SCHOOL PUPILS		TOTALS	RATIO OF SCHOOL POPULATION TO TOTAL POPULATION
		Boys	Girls		
England and Wales	36,075,269 (1911)	96,789	81,573	178,362	1 : 202
France (alone)	39,601,509 (1911)	96,791	34,989	131,780	1 : 300
Prussia	40,163,333 (1910)	232,792	95,492	328,284	1 : 122
United States	91,972,266 (1910)	489,048	616,312	1,105,360	1 : 83

TOPICS FOR FURTHER STUDY

1. Compare the secondary school organization in France and Germany.
2. Compare compulsory attendance regulations in France, Germany, and England.
3. Compare advantages and disadvantages of centralized school control.
4. Compare school athletics in France, Germany, and England.
5. Compare length of the school year in France, Germany, England, and the United States.
6. Compare aims and methods of instruction of each subject of secondary school study in any of the foreign school systems.
7. Compare influence of national ideals in determining aims and methods of instruction of the various subjects of instruction.
8. Formal spelling does not figure among the subjects of instruction even in the elementary classes of the secondary schools abroad. How is this subject taught?

9. Make a diagram showing comparative lengths of secondary courses in France, Germany, England, and the United States.

10. Compare the time allotment for any subject of instruction in a foreign secondary school with that of the corresponding subject in the United States.

11. In the French and German secondary schools most subjects continue throughout the course. Contrast the results of this method with those obtained from the practice which prevails in the United States of pursuing a few subjects intensively.

12. How do you account for the existence of the American practice as noted above?

13. The training of secondary teachers abroad.

14. The position of the teacher in any foreign school system in comparison with his position in the United States.

15. Teachers' pensions in France and Germany.

16. To what extent have the school organization, aims, or methods of instruction in any foreign secondary school system influenced the corresponding development in the United States?

17. Contrast an English "Public" School with an American public school. (Select a particular school in each instance.)

18. Evaluate the attainments of the French or German boy on leaving the secondary school in terms of American educational progress.

REFERENCES — FRANCE

Assistant Masters' Association, England. *Conditions of Service of Teachers in English and Foreign Secondary Schools*. London, 1910.

Documents:

Bulletin administratif du Ministère de l'instruction publique (weekly).

Official publication of the Education Department.

Enquête sur l'enseignement secondaire. Report of the Ribot Commission. Paris, 1899.

COMPAYRÉ, G. Education in France. In MONROE, *Cyclopedia of Education*. New York, 1911.

FARRINGTON, F. E. *French Secondary Schools*. New York, 1910.

GIRARD, R. DE. *Questions d'enseignement secondaire*. Paris, 1905.

Great Britain, Board of Education, *Special Reports on Educational Subjects*. Vol. XXIV, Secondary and University Education in France. Contains a complete English translation of the present secondary school curriculum.

HUGHES, R. E. *The Making of Citizens; a Study in Comparative Education*. New York, 1902.

- LANGLOIS, CH. V. *La Question de l'enseignement secondaire en France et à l'étranger*. Paris, 1900.
- PERKINS, H. A. The Educational System of France. *Educ. Rev.*, March, 1911.
- Plan d'études et programmes d'enseignement dans les lycées et collèges de garçons*. Paris, 1913.
- Plan d'études et programmes d'enseignement dans les lycées et collèges de jeunes filles*. Paris, 1913.
- SADLER, M. E. The Unrest in Secondary Education in Germany and Elsewhere. In Great Britain, Board of Education, *Special Reports on Educational Subjects*. Vol. IX. London, 1902.
- United States Bureau of Education. *Reports of the Commissioner of Education* (annual). Especially, 1906, I, pp. 19-26 (discussion of the "law of separation"); 1907, I, pp. 142-157; 1908, I, pp. 230-238; 1909, I, pp. 420-432.

REFERENCES — GERMANY

- Assistant Masters' Association, England. *Conditions of Service of Teachers in English and Foreign Secondary Schools*. London, 1910.
- BOLTON, F. E. *The Secondary School System of Germany*. New York, 1900.
- BROWN, J. F. *The Training of Teachers for Secondary Schools in Germany and the United States*. New York, 1911.
- Great Britain, Board of Education, *Special Reports on Educational Subjects*. Vol. I, The *Realschulen* in Berlin. — The *Oberrealschulen* of Prussia. Vol. III, Problems in Prussian Secondary Education for Boys. — Curricula and Programs. Vol. XX, Teaching of Classics in Prussian Secondary Schools.
- GÜLDNER, H. *Die höheren Lehranstalten für die weibliche Jugend in Preussen*. Halle, 1913.
- HUGHES, R. E. *The Making of Citizens; a Study in Comparative Education*. New York, 1902.
- LEXIS, W. *Das Unterrichtswesen im deutschen Reich*, Vol. II. Berlin, 1904.
- NORWOOD, C., and HOPE, A. H. *Higher Education of Boys in England*. London, 1909.
- PAULSEN, F. *German Education Past and Present*. Trans. by Lorenz. New York, 1908.
- PRETTYMAN, C. W. Higher Girls' Schools of Prussia. *Teachers College Record*, May, 1911.
- RUSSELL, J. E. *German Higher Schools*. 2d ed. New York, 1905.

- SADLER, M. E. The Unrest in Secondary Education in Germany and Elsewhere. In Great Britain, Board of Education, *Special Reports on Educational Subjects*. Vol. IX. London, 1902.
- Statistisches Jahrbuch der höheren Schulen* (annual). Leipzig.
- United States Bureau of Education. *Reports of the Commissioner of Education* (annual). Articles usually appear under Education in Central Europe.
- ZIERTMANN, P. Education in Germany. In MONROE, *Cyclopedia of Education*. New York, 1912.

REFERENCES — ENGLAND

- Assistant Masters' Association, England. *Conditions of Service of Teachers in English and Foreign Secondary Schools*. London, 1910.
- BALFOUR, G. *Educational Systems of Great Britain and Ireland*. 2d ed. Oxford, 1903.
- Board of Education. *Reports* (annual). Latest 1911-1912.
- Statistics of Public Education in England and Wales* (annual).
- Part I. Educational. Latest 1910-1911.
- Part II. Financial. Latest 1910-1911-1912.
- Office of Special Inquiries and Reports.
- Educational Pamphlets*. See particularly series on *The Modern Side at Secondary Schools*.
- Special Reports on Educational Subjects*. Vols. I, XXII.
- BURSTALL, S. A., and DOUGLAS, M. A. *Public Schools for Girls*. London, 1911.
- CORBIN, J. *Schoolboy Life in England*. New York, 1898.
- HUGHES, R. E. *The Making of Citizens; a Study in Comparative Education*. New York, 1902.
- MACLEAN, A. H. H. *The Law of Secondary Schools*. London, 1909.
- MINCHIN, J. G. C. *Our Public Schools; their Influence on English History*. London, 1901.
- MONTMORENCY, J. E. G. DE. *National Education and National Life*. London, 1906.
- Progress of Education in England. English Educational Organization from Early Times to 1904*. London, 1904.
- NORWOOD, C., and HOPE, A. H. *Higher Education of Boys in England*. London, 1909.
- Public Schools from Within*. London, 1906.
- Public Schools Yearbook* (annual). London.
- SANDIFORD, P. *The Training of Teachers in England and Wales*. New York, 1910.

Schoolmasters' Yearbook (annual). London.

SMITH, A. S. Education in England. In MONROE, *Cyclopedia of Education*. New York, 1911.

United States Bureau of Education. *Reports of the Commissioner of Education* (annual). Chapters on Education in Great Britain and Ireland. Especially 1911, I, pp. 541-550.

YOXALL, J. H., and GRAY, E. *The Red Code* (annual). London. Contains official regulations of the Board of Education.

CHAPTER IV

THE HIGH SCHOOL SYSTEMS OF THE UNITED STATES

STATE SYSTEMS. — The high school of the United States has, upon the whole, evolved from the free elementary school. Its development has followed that of its progenitor by approximately a quarter of a century, so that in many states it remains as yet almost entirely unsystematized, so far as the legal aspect is concerned.

Legal Provisions. — In a number of states, only the most general legal provision is made for the establishment and maintenance of such schools, while in a few of the Southern and in at least one of the Northern states, New Jersey, no special legal provision is made for them, such schools as exist being considered merely as the higher grades of the public schools. Most of the states have, however, made definite legal provision for these schools, and a large number, such as Maine, Massachusetts, New York, Indiana, Wisconsin, Minnesota, and California, have evolved comprehensive independent laws governing the establishment, maintenance, and management of such schools. But the legal provisions even of these states differ widely among themselves, so that the laws governing this institution in the United States range from indefinite and badly defined codes in certain states to clear and specific legislation in others.

The General Type. — Nevertheless the high schools in the various states have a remarkable resemblance in external and internal management and control, as well as in their curricula. In general no greater differences exist internally

between the high schools of Maine and those of California than may be found to exist between the different high schools of any given commonwealth. This similarity is due to a number of factors in American life and American educational practices. In the first place, the elementary schools, the feeders of the high schools, resemble one another even more closely than do the high schools. The colleges, the universities, and particularly the state universities, the institutions that largely receive the output of the high schools, also closely resemble one another.

The explanation of this close resemblance of the various types of schools in the American system of education is largely due to imitation, brought about by the following facts and conditions: (1) most of the states of the Union are relatively new and their populations have been largely recruited from the other older states; (2) the Americans are a migrating people, and recognize no state boundaries in their shifting from place to place; (3) there is wide communication through travel, books, and periodicals; (4) national and state conventions of teachers, principals, and superintendents are held annually, — the state conventions usually employing outside instructors to present the work; (5) teachers are to a considerable extent recruited from the country at large rather than from the local community and state alone; (6) students frequently leave their own communities and state to prepare for their work of teaching. In addition the laws governing the establishment, maintenance, and support of all of these types of schools have been more or less influenced by the laws and practices of other states.

In no point, however, do the high schools of the Union so closely resemble one another as in their curricula. This is due to the fact that this institution has been, and is to-day, fundamentally a preparatory school to the colleges and universities, which by association and concerted action have set a more or less definite standard of requirement for entrance,

and thus to a large degree have dictated a common curriculum for these schools.

Ever since the rise of the high school in this country its ablest advocates have dreamed of it as the finishing college of the common people; but as yet the fruition of this dream has not been accomplished, — unless, indeed, the college preparatory course can be considered the best preparation for social efficiency. This condition has been no more the fault of the college and the university than of those who have insisted upon a different curriculum, but who in the past have been unable to evolve one definite enough to be workable in many of the thousands of high schools of the country. However, the present widespread interest in vocational, industrial, technical, commercial, and economic training, and the growing interest in the refinement of the other common aspects of life, together with the practical experiments now going on, give a renewed promise for the fruition of this dream of a people's college. The American high school, then, in so far as it is efficient, owes this efficiency in large measure to the college and the university.

The systematizing of any series of schools of a given type means their unification; and this can be secured only through the operation of one or more of the four following instrumentalities: similar laws governing their establishment, maintenance, and support; like curricula; supervision and inspection; and teachers with similar ideals and training.

Organization of Control. — The most prevalent local political unit of organization for the establishment, maintenance, control, and support of high schools in the United States is the district, which includes the city or parts of the city, the town or small city, the village, the rural district, or a union of such districts. This system prevails in all of the states in so far as it applies to the cities and larger towns, and in some states it is the only unit of organization for the establishment of such schools. In most instances the local board

of school directors or school trustees, which also has charge of the local lower schools, controls these schools.

In the rural districts of many of the Eastern and Middle Western states the township unit of organization prevails both for elementary and for high school purposes. In certain of these states the district unit of organization prevails for elementary school purposes, while the township unit prevails for high school purposes. In most of them there are also union or joint township high schools in existence. The boards of education which are in control of these schools are elected by the people of the territorial districts maintaining them. In some of the Southern, Western, Rocky Mountain, and Pacific Coast states many county high schools exist, and in at least a few cases joint county high schools. These schools are always under the control either of the county boards of education, which have also duties relating to the elementary schools, or of special county or joint county high school boards. In a few states these boards are appointed by the county courts, in others by the county commissioners or supervisors, and in the remainder of the cases they are elected by the people.

Rural High Schools. — Since in general the towns and villages of the United States with populations to exceed 2500 are able to maintain reputable high schools, and since they have for years been doing so, the main problem of rural secondary education has to do mostly with that part of the population residing in the smaller villages and on the farms of the country. The units of organization for rural high school purposes vary widely in the different sections of the country as well as in some of the states themselves, the smallest of these units being the district. These district high schools, in so far as they may be classed as rural, have largely grown out of the elementary schools through the gradual addition of high school subjects and high school grades. This is particularly true in such states as have had the dis-

strict unit of organization and control in matters of education. In every state where the unit of control is such, and where the law has failed to define the public school as a strictly elementary school, rural high schools have grown up as district schools. The union of districts for high school purposes is also an outgrowth of the gradual extension of the elementary school. As a type it is the result of combining two or more advanced district schools that had already developed considerable high school work in connection with their elementary courses. The township unit of organization is more prevalent than the district unit, in so far as the term applies to such rural high schools as have state recognition as such. This is a perfectly natural condition, since in most of the older and wealthier states, the Eastern and Middle Western groups, the township constitutes the unit of taxation and organization for public school as well as other civil purposes. The method of uniting townships into high school districts has also been employed to a considerable extent, particularly where the townships covered a small area, or where their most thickly populated areas were adjacent. The county plan of organization is quite largely practiced in the Western and in certain of the Southern states. This plan of organization almost always implies large local support, and is especially adaptable to thinly populated districts. Village and town districts sometimes unite with their counties or with their own townships or with a group of adjacent townships in the establishment and maintenance of union high schools. In fact, in a large number of the states any combination of unit areas may organize itself into a high school district.

Curriculum. — The courses of study in the rural high schools are very similar to those of the city high schools in the states wherein they are located. The most notable difference is that they offer a smaller number of courses, which is a direct result of the small teaching force employed and of the small number of pupils in attendance. Most of the states, recog-

nizing that these schools are at least in theory finishing institutions, have required one course of instruction other than the classical, making the foreign languages elective, if offered at all. In most cases, however, these schools give also a college preparatory course, including at least one foreign language, usually Latin, though the modern languages are rapidly gaining ground.

The present tendency is to create for these schools courses of a more practical nature. This is to be accomplished by modifying the courses and instruction in the sciences, and adding courses in agriculture, stock raising, dairying, horticulture, and other practical subjects, as demanded by the particular school. So far little of a practical nature has been accomplished in this line. In fact, in regard to practical education, the cities are at the present time far in advance of the rural districts. Some of the Middle Western states, such as Wisconsin, Michigan, and Nebraska, have made considerable progress in this line.

Another tendency worthy of note is that of recognizing and aiding rural high schools which offer only a partial course of study, particularly the two-year rural and small village high school. Such schools are becoming common in the upper Mississippi Valley, though as yet only a few states have granted them any special financial encouragement. California, with its two-year "Grammar-High" schools, is a notable exception in this particular.

Statistical Summary.—A statistical statement of the number and condition of the strictly rural high schools in this country is not possible, because, as pointed out above, the statistics of rural high schools proper are combined with those of all villages and towns having populations that do not exceed 8000 inhabitants. The increase in the number of reputable non-urban high schools is a good index to the vitality of the institution at the present time.

The following statistical summary is based on an extended

study of twenty states selected because of their availability for the purpose. These were Maine, Massachusetts, New Jersey, California, Colorado, Washington, Connecticut, Vermont, New Hampshire, Michigan, Wisconsin, Minnesota, Ohio, Indiana, Illinois, Iowa, Missouri, Texas, Kansas, and Nebraska. The high school and other necessary statistics for these states for the nine years ending 1906 were compiled, and interpreted with the following general results:

(1) The average increase in the number of rural¹ high schools in the twenty states was, for the nine-year period, 50 per cent. (2) The average relative² increase in the enrollment of pupils in the urban³ high schools of the twenty states was, for the nine years, 46 per cent, while for the non-urban¹ high schools it was, for the same period, 65 per cent. (3) The average increase to the school in the number of teachers employed in non-urban high schools was, for the nine years, more than 19 per cent. (4) The average decrease in the relative number of one-teacher high schools was, for the nine years, more than 11 per cent. (5) The average decrease in the relative number of two-teacher high schools was, for the nine years, more than 33 per cent.

The general methods employed by different states in extending financial aid to rural secondary education are varied, and are discussed in the following section.

The influence of this aid upon the rural high schools of these states is clearly shown by the following comparison of the average development of rural secondary education during a period of nine years, 1897-1906, in six states, Minnesota, California, Massachusetts, Washington, Wisconsin, and Maine, — all of which provided state subsidies to rural high schools and two of which also provided for the reimbursement of

¹ All high schools not located in cities with a population exceeding 8000 inhabitants.

² Enrollment for each year compared with census, five to eighteen years.

³ High schools in cities with 8000 or more inhabitants.

tutions, — with the average development of rural secondary education during the same period in eleven states, Nebraska, Ohio, Indiana, Kansas, Colorado, Michigan, Illinois, New Jersey, Iowa, Missouri, and Texas, none of which provided direct state aid to secondary education in any manner whatever. The results were as follows :

(1) The average increase in the number of non-urban high schools was, for the six states, 68 per cent, for the eleven states, 48 per cent. (2) The average increase in the number of teachers employed to the school in non-urban districts was, for the six states, 38 per cent, reckoned on an average status of 2.4 teachers to the school in 1897; for the eleven states 6.5 per cent, reckoned upon an average status of 2.5 teachers to the school in 1897. (3) During these nine years the average relative proportion (.25) of one-teacher high schools in the six states was reduced 63 per cent; in the eleven states the average relative proportion (.27) was increased 15 per cent. (4) During the same period the average relative proportion (.52) of two-teacher high schools in the six states was reduced 53 per cent, while in the eleven states the average relative proportion (.44) was increased 2 per cent. (5) The average status of enrollment of pupils in all types of secondary schools, 4.44 individuals to each 100 of census (5-18), in the six states in 1897 was increased during the nine years 57 per cent, while in the eleven states the average status of enrollment, 3.68 individuals to each 100 of census (5-18), was increased but 39 per cent. (6) The average status of enrollment of pupils in city high schools, 4.81 individuals to each 100 of census (5-18), in the six states in 1897, was increased during the nine years 52 per cent, while in the eleven states the average status of enrollment, 4.13 individuals to each one hundred of census (5-18), was increased 49 per cent. (7) The average status of enrollment of pupils in non-urban high schools, 2.85 individuals to each 100 of census (5-18), in the six states in 1897 was increased during the nine years

100 per cent, while in the eleven states the average status of enrollment, 2.49 individuals to each 100 of census (5-18), was increased 49 per cent.

Thus it appears that the rapidly developing standard of rural secondary education in the states that provide special financial aid is slowly approaching the increasing standard of the same in the cities of these states. On the other hand, it appears that the rapidly increasing standard of rural secondary education in the states that offer no special aid is slowly diverging from the constantly increasing standard of the same in the cities of these states. On the whole the general increase of standard of urban as well as non-urban secondary education has been very rapid in recent years.

MAINTENANCE AND SUPPORT.—It is only within recent years that any real attempt to aid in the maintenance of secondary schools has been made by the states or counties, and the giving of such aid, though becoming more common each year, is still not a general feature of our state school systems. In some states no distinctions are made between common or elementary schools and high or secondary schools, either in statistics or in finance. Communities which maintain secondary schools are placed on the same footing as communities that do not, with the result that the maintenance of a high school is purely a local burden. Secondary education is, comparatively speaking, so recent an undertaking that most states have not as yet made any definite provision for the equalization of its advantages. These schools, however, have recently grown greatly in popular favor, due in part to the need of increased education to meet the changed conditions of life, to the introduction of new studies and methods of instruction, and to the changed conception of the purpose of secondary instruction. The result is that the high school is destined soon to be a regular and a necessary part of our systems of public instruction and that high school facilities will be provided for all. This change in attitude is certain

to add force to the demand for some form of general aid for secondary, as well as for elementary, instruction. The maintenance of elementary schools and a state university, and the refusal to help in the maintenance of secondary schools, is not a logical position for a state to assume.

The expense of maintaining secondary schools is so much greater than that for elementary schools, due to the need of better trained and more expensive teachers, smaller classes, the smaller number enrolled, and more expensive teaching equipment, that the need of some general aid is apparent, if they are to be developed at all generally. This is accentuated by the fact that the cost for elementary schools is also increasing, and that the money now at hand and originally intended for the support of elementary schools alone is rapidly proving insufficient for the support of both classes of schools. Many communities are at present trying to support a full twelve-year school system with funds hardly sufficient to maintain the elementary schools properly.

Such provision as has been made by the different states extends from mere permission to communities to form such schools and to tax themselves to pay for them, — which is analogous to the first legislative permission to the people of a community to organize a taxing district and tax every one for the support of an elementary school, — to a general state tax levied for the support of secondary education and apportioned and used for that purpose alone. The first is the mere beginning and the second is the culmination of the process, and between the two are many intermediate plans for the granting of some degree of aid to secondary schools.

Stages in Development. — Mere permission to cities, towns, districts, and unions of districts to form a high school and to tax themselves to pay for it must be regarded as the first step in the process of the evolution of a system of general aid to secondary education. A petition and an election are the usual preliminary steps, and after the formation of the

high school district an annual local tax, frequently of a limited amount, is permitted for the support of the school. Sometimes such schools are under the control of a separate school board, known as a high school board, and sometimes the board which has control of the elementary schools merely takes charge of the high school also. A number of states have taken this first step, but have not gone further. The next step is found where the principle of local support is retained, but the taxing is extended to a larger area, as to the county as a whole. In states which have taken this step, common in the West, we find the county high school. The common features of these permissive high school laws are the necessity of a petition asking for the submission of the question of the formation of a county high school to a vote of the people, a special election to decide the question, the appointment or election of a board of trustees for the school, an annual county tax for support, free tuition in the school to all residents of the county, and usually provision for the dissolution of the school, after a time, if desired, by vote of the people. With the formation of a second county high school at some other place, or with the segregation of a certain district or districts to form a local high school separate from the county high school, the process of subdivision of the high school district has begun.

The next step in granting aid to high schools is taken when the state begins to make a series of grants, or subsidies, to aid secondary schools. A number of states have taken this step, though the plan has been worked out but poorly in most of the states. The granting of such aid naturally stimulates the development of high schools, and if the appropriation to pay the grants or subsidies is not of a flexible form, and one that increases with the growth of the schools, the result will be a failure to provide the aid intended. Where a definite legislative appropriation has to be made to pay the grant, as in a number of the states, the appropriation is likely to fail

to increase as fast as the schools do, and the result is a forced scaling down of the grant. In Minnesota, for example, the state aid determined upon was \$1000 to each properly approved school, but the schools increased so much faster than did the appropriation that the grants were scaled lower and lower for a number of years. The same thing happened in Pennsylvania. This gives an uncertainty to the value of the grant which makes the method less desirable than other plans that can be devised. The method, also, places all of the premium on the mere existence of the school, but none on the employment of a sufficient number of teachers to do the work properly, or on the addition of such subjects of instruction as will make the school of greater worth. A school with only a single "classical course" stands on the same footing, so far as state aid is concerned, with another school which employs relatively more teachers and offers two or three courses of instruction. The second school will cost much more per capita to maintain, assuming that the two are located in somewhat the same kind of communities, and will attract more students and will render a much larger educational service, but under the lump subsidy plan of aid it will receive no greater reward than the smaller and poorer school. If it is worth while to aid secondary education at all, then the state ought so to apportion its aid as to place a premium on the giving of instruction under good educational conditions. The subsidy method places no premium on growth or better instruction, and makes the position of the state as to the improvement of existing conditions a purely negative one. The subsidy method marks the beginnings of state aid, and ought to be abandoned as soon as possible for a better form of assistance. If the subsidy plan is to be used, it ought to be graded both as to years and character of instruction offered, and the power to grant, scale down, or withhold the grant ought to be centralized in some responsible educational body possessing powers of inspection. The one marked merit of

the subsidy plan, where graded subsidies are employed based on the number of years of instruction offered, is that it places a premium on the development of two-year and three-year high schools, as well as four-year schools. Any good instruction beyond the grammar school, even if for only one year and given to only a few pupils, is a stimulating influence which reacts most favorably on all lower instruction. Two-year high schools frequently develop into four-year high schools, and communities are usually able to provide two years of instruction before they would be able to provide a fully equipped four-year high school.

Types of Highest Development. — California and New Jersey stand as examples of states which have reached the culmination of the process. In both states the high school has been adopted as a part of the state school system, though by a somewhat different method in each. In California the complete adoption of the high school has come through the provision of separate and special taxation for the support of high schools and by a constitutional provision that the income from the state school fund, and the proceeds of all previous taxation, can be used only for the support of elementary schools. This forever prevents the robbing of the elementary schools to maintain high schools, a process which goes on in many of our states. For the support of the high schools of the state a special state tax for high schools is levied and apportioned. To keep the income for this purpose constantly up to the needs of the schools, it has been provided that the tax to be levied shall be determined annually by multiplying the number of high school pupils in average daily attendance in the state the preceding year by \$15, which requires a state tax of approximately $1\frac{1}{2}$ mills. This is then apportioned to all approved high schools in the state on the following basis: one third equally to all schools, regardless of size, and two thirds to all schools on the basis of average daily attendance. The apportionment plan could be im-

proved still further by making a partial apportionment on the basis of the number of teachers actually employed. Length of term is here a negligible factor, because all schools are required to maintain a term of at least 180 days to receive any aid. New Jersey offers an example of the complete incorporation of secondary education into the state school system. Here the apportionment of school funds is made to high schools as to elementary schools, on the teacher basis, viz. \$400 for every teacher actually employed in each high school, and the remainder on a basis of so much per pupil per day in actual attendance, in all kinds of schools. The apportionment of state aid to a high school is thus made on a plan similar to a kindergarten, primary school, or grammar school. All belong to the same state school system, all share in the apportionment of funds, and all are paid out of a common fund. The value of such a plan, if sufficient revenue can be obtained, is at once evident. High schools cease to be a separate part of the school system, and become an integral part of the system of public instruction. The state then rewards a community's efforts according to the amount of instruction provided, as measured by the number of teachers employed, and according to the actual amount of work done, as measured by the attendance upon the instruction offered. If a rural union school will provide only the ninth-grade work, and thus give the boys and girls in the rural districts a taste of something beyond the common school branches, the state will reward such an effort by a grant for both the teacher employed and the extra attendance resulting. If a village will employ one additional teacher and provide two years of high school instruction, the state will similarly reward such effort. To the large city school the state offers a similar standing premium on additional effort, every new teacher and line of work added receiving additional aid. The simplicity, justice, and automatic adjustment of the plan to community needs and efforts are strong points in its favor. One

thing, though, which ought always to accompany such a complete incorporation of the high schools into the public school system, is a proportional increase of available funds, with provision for an automatic increase. There is no wisdom in incorporating high schools into the state school system if the elementary schools are to be made to pay the bills.

Basis of Apportionment. — Such an incorporation of high schools into the system of public instruction is not possible if the census basis of apportionment is used. The essential unit in higher, as in elementary, instruction, is the teacher who must be employed to teach the pupils, and not the number of pupils alone. Under a combination of teachers-actually-employed and attendance bases, as used in New Jersey, the high school is placed on the same basis as any other school, and thus becomes an integral part of the system of public instruction. The California and the New Jersey plans are the best that have been evolved for the support and incorporation of high schools. The California plan is especially meritorious in that it provides a separate and a large fund for aid to secondary education, and the New Jersey plan is especially commendable in that it establishes one organization. In view of the possibility of a reorganization of the plans for upper grammar grade and high school instruction this must be considered an important gain. If in the future a six-year high school should prove to be a desirable addition to our school work, the present somewhat rigid classification in some states would stand in the way.

Another form of support for high schools comes in the attempt to abolish tuition fees for those children who do not happen to live in high school districts. Children who live in cities, towns, or districts which maintain high schools of course have free high school tuition, but children who live in adjoining districts which are not a part of some high school district are almost invariably forced to pay a tuition charge, and this is frequently made very high for the purpose of re-

ducing the attendance of such outside pupils. The unfairness of such tuition charges is at once evident, and a number of states have attempted to do away with them. The method employed in doing so varies in different states. In Indiana the pupil applies in person for a transfer, which, if granted, carries with it the payment of fees; in Ohio the township from which the pupil comes is directed to assume the fees; in Wisconsin a bill is presented by the school receiving the pupil to the district from which he comes, and then a tax is levied to pay the bill; in Massachusetts the town in which the pupil resides must pay the tuition charge, unless it is one of a class of poorer and smaller towns, in which case the state pays the bill; and in Connecticut the state reimburses towns for two thirds of the tuition paid, and will also pay one half of the cost of transportation. In California a very simple and very effective method has recently been worked out, whereby every child in the state has free high school privileges. The county superintendent of schools of each county is required to estimate annually the number of probable high school pupils for the coming year who live in non-high-school territory, and then to have levied by the county authorities a county high-school-tuition tax sufficient to pay the tuition charge of all non-high-school district pupils in the nearest or most convenient high school. As the state pays the high schools for all pupils in average daily attendance, this includes state aid to all. It remains purely optional with a district now whether it will form a high school of its own, join a high school district already in existence, or pay its tax for the tuition of non-high-school pupils. In any case the cost is paid by general taxation, levied on all property for high school purposes.

THE INSPECTION AND ACCREDITING OF SCHOOLS.

—This phase of high school administration is primarily one of relationship between the secondary schools and the colleges, and has to do chiefly with methods of transferring students from high school to college.

Considered historically and broadly there are found in the United States but two methods of admission to college: (a) personal examination of the applicant, — the Eastern method; (b) accrediting of the fitting school, — the Western method.

The examination method is the older; but originally this was a purely personal affair between the applicant and the college teacher. The "examination," quite informal and usually oral, was designed only incidentally to test the boy's knowledge, but mainly to acquaint the college teacher with his prospective student's tastes, habits, and antecedents.

However, as the number of applicants increased, this informal, individual method became unwieldy, and was finally superseded by formal, written examinations, set by the college. Thus by and within this method the valuable element of personal contact between college teacher and would-be student was wholly lost.

Further, in the North Atlantic states, where the examination method began and found its fullest development, schools and colleges were mainly private institutions, without any feeling of institutional relationship, without the sense of coherency and solidarity of a common educational purpose. As for educational system — there was none. Each college was a law unto itself; independent and answerable to none, it determined and defined its own entrance requirements and held its own entrance examinations upon its own premises; while the schools knew no law except that which was laid upon them by the colleges. Too frequently this law had little reference to the proper problems of secondary education. The term "atomistic" best describes such an educational condition.

While this condition of individualism continued with little change until very recent times, one modification may be noted. Some of the larger eastern colleges, which draw students from a wide area, have come, in recent times, to

hold their examinations at various geographical centers, thus relieving somewhat the hardship incident to long trips with uncertain results.

The latest and only important development of the examination system is the establishment of an examination board. Such a board, called the College Entrance Examination Board of the Middle states and Maryland, was organized in New York City in 1901. The organizers were representatives from certain leading colleges and secondary schools of the Middle Atlantic states. The chief purposes of the Board were: (a) to hold at many points, here and abroad, uniform college entrance examinations, the constituent colleges agreeing to discontinue their own examinations and accept the Board's results; (b) to define and standardize the college entrance "units" in the different subjects.

The plan was welcomed by both schools and colleges, especially in the East, as a vast improvement upon the old methods; and the operations of the Board have within the decade of its existence greatly extended. Its examinations are now held in practically all civilized countries, and the results are accepted by every college and university in the United States.

We come now to consider the "Western" system, which is, instead, essentially an examination of the school. This is commonly called the certification or accrediting of schools. Stated broadly, according to this method the college, having in some way satisfied itself as to the quality of the work done in the school, agrees to accept, in lieu of examinations, a statement from the school to the effect that the applicant has done the required work satisfactorily and is qualified to do college work.

The theoretic justification of each system, in so far as it relates to fitness for admission to college, is as follows: (a) The college is the best judge of what constitutes fitness to enter college, and examination is the best test of fitness. (b) The

teacher, knowing both the boy and his work and the college requirements as well, is the best judge.

The merits of these two positions cannot be discussed here, for, in its origin at least, the accrediting system had a deeper justification. It came naturally with the recognition of the solidarity of a state educational system wherein all members have a unity of purpose and of which the state university is the natural head. While this condition was characteristic of the West generally, it reached its earliest practical recognition in Michigan. In the annual catalogue of the University of Michigan for 1870-1871 appeared a "Special Notice to Preparatory Schools," whereby the faculty agreed that, under certain conditions, the holder of a diploma of graduation from a school might be admitted to the University without examination.

Chief among the conditions, as modified by the experience of a few years, were in substance the following:

(1) The work of the school must be inspected by a committee of the university faculty and favorably reported; (2) Accrediting was granted for but one year at a time; (3) Applicant must present to the university diploma of graduation from the school; (4) The school must apply to the university yearly for the accrediting; (5) Only public high schools within the state were accredited.

Here we find those principles clearly recognized which are characteristic of the Western plan and in contrast with the Eastern: (a) that there is an organic relationship between the different parts of the state educational system; (b) that examination should be not of the candidate but of the school; (c) that the teacher is the best judge of what his pupil is, of what he knows, and of what he can, and probably will, do in college.

The theoretic reasonableness and the practical efficiency of the Michigan plan, as it soon came to be called, appealed to the West, which, being less hampered than the East by edu-

cational tradition, was freer to try out educational innovations. So, as the states developed, the essential features of the accrediting system, with individual state modifications, were adopted by practically every state west of the Alleghanies. While in a few cases the state department of education undertook the accrediting of schools, as a rule that function was assumed by the state university, as in Michigan.

In those states where the original plan was most fully and typically carried out, *e.g.* in Michigan and in California, the examination of the schools, which was the most essential feature of the plan, was one of subject in the high school and by corresponding departments of the university. Representatives — preferably heads — of the various university departments of instruction visited and inspected yearly the corresponding subjects of instruction in the schools. Thus a school might be accredited in some subjects and not in others.

So long as the schools of a state were few and small, with narrow curricula, this plan was usually effectively carried out. But in time difficulties arose. The first was of administration from the university side. With the enormous growth of the high schools of the past two decades in numbers, size, and complexity of curricula, this feature of the plan grew more and more unwieldy, difficult of execution, and finally impracticable. Not enough experienced men could be spared from the various university departments to do the work; so younger men, often unacquainted with secondary school work, were sent; later, even these could not be spared in sufficient numbers to cover the field. Finally the cost, which was borne by the university, became well-nigh prohibitive. In 1905 one state university was expending in the work over \$10,000 per year and even then was not able to cover the field adequately.

The second arose in the attitude of the schools; for the schools, which at first had warmly welcomed the accrediting system and had been tremendously benefited by university

coöperation, came in time to feel the hand of the university heavy upon them and to chafe under it. And they had reason. For with the changed conditions sketched above, injustice was frequently — however unintentionally — done to teacher, pupil, and school. Moreover, with the rapid expansion of the high schools, the conviction gained ground that the larger purpose was to fit the many for life rather than the few for college; that the secondary school should be considered as a whole as an institution with its own true ends, rather than as a loose aggregation of unrelated subjects of instruction leading to college admission. So there were sent to the schools fewer departmental specialists and these less frequently; the minute yearly inspection of each subject was given up, and the university came gradually to recognize the school as an autonomy, to be judged rightly only as a whole.

The next step was a logical one. Instead of the numerous departmental specialists of former years, the university appointed one general examiner, who usually became a member of the university department of education. Generally he was to spend one part of the school year in university instruction and the other in visiting the schools. Officially he was expected to view the school as a whole, to note in how far it measured up to recognized standards of modern secondary school efficiency. Upon his report, as a rule, the school was accredited, if at all, as a whole and not by individual subjects as heretofore. Such an accredited school was permitted to enter its graduates at the university without examination on the recommendation of the principal and a statement that the applicant had satisfactorily completed the entrance requirements.

As conducive to more intelligent coöperation between the schools and the universities, some of the latter kept a detailed scholarship record of the work done in the university by the freshmen entering from each school. These records were

sent to the principals of the corresponding schools at the close of the first semester, and were also used as additional data for determining the right of the school to be accredited the following year.

So far we have sketched, by sample, the development of the accrediting system of the West. In some states, especially in the far West, the standards set by the state university have been generally accepted by the private colleges of the state; but in the states of the Middle West this has not been so generally true. In many of these states there are important private colleges and universities, and the educational leadership of the state universities has not been so unquestioned. Under these circumstances, each of the more important institutions has sought to maintain its own admission requirements and its own accrediting system. This has resulted in vast waste through duplication of effort on the part of the colleges, and much needless annoyance on the part of the schools. In such cases we find, though to a less degree, an educational atomism akin to that of the East.

To render the accrediting system more widely effective there was need of an organization which would act as a clearing house, and do for many states and for all colleges within those states what many of the individual states were already doing effectively for their own territory.

An organization with such an end in view came into existence in 1901 when the North Central Association of Colleges and Secondary Schools formed a "Commission of Accredited Schools." Its chief purposes were: (1) to define and describe "unit" high school courses of study in the different subjects; (2) to serve as a standing committee on uniform college admission requirements; (3) to secure uniformity in the standards and methods, and economy of labor and expense in the work of high school inspection; (4) to prepare and publish a list of accredited schools.

In its first report, issued in 1902, the General Commission

made certain recommendations. The important ones, as slightly modified later, stand now as follows: (1) "A unit course of study in a secondary school is defined as a course covering an academic year that shall include in the aggregate not less than the equivalent of one hundred and twenty sixty-minute hours of classroom work, two hours of manual training or laboratory work being equivalent to an hour of classroom work." (2) High school graduation and college admission would include fifteen units so defined. (3) All high school curricula and all requirements for college entrance should include three units of English and two units of mathematics.

The subcommittee on high school inspection recommended the following criteria by which accrediting should be determined, the length of the accrediting term being one year: (1) The minimum scholastic attainments of all high school teachers shall be the equivalent of graduation from a college belonging to the North Central Association, including special training in the subjects they teach. (2) No teacher shall have more than five daily recitations of forty-five minutes each. (3) The school shall have adequate laboratory and library facilities for handling properly the subjects taught. (4) The location, construction, and sanitary arrangements of the buildings "shall be such as to secure hygienic conditions for both pupils and teachers." (5) Schools must rank well in general efficiency of instruction, and in intellectual and moral tone. (6) A school must have at least four teachers of academic subjects; the average number of pupils per teacher must not be above thirty.

Visitation and examination of the schools was to be done by a Board of Inspectors. From five, at first, the number of inspectors had grown in 1912 to twenty-one. Seven of these are the regular official inspectors, each representing the department of education of his state; fourteen are representatives of the universities and colleges belonging to the

North Central Association. In one or other form fourteen states are represented.

The Board intended from the first that its accredited schools should constitute an honor list, and went to work very conservatively. The first list of accredited schools was published in 1904, and contained the names of 157 schools representing ten states; on the list of 1912 there were 837 schools representing eighteen states.

The work of the Board has been extremely valuable. It has proved to be, within its field, the greatest administrative agency yet devised; it is coördinating the different schools and colleges throughout a wide area; it is reducing to a minimum of expenditure, with a maximum of efficiency, the labor and cost involved in the former methods; it is steadily fostering and enhancing the growth of cordial relations between schools and colleges.

In 1911, the Southern Commission on Accredited Schools was formed by the Association of Colleges and Secondary Schools of the Southern States.

The commission was charged with preparing a "Southern List of Accredited Schools for the use of the colleges of the South and of other sections, and furthermore, to stimulate and aid the high schools to reach higher standards of scholarship and better conditions for teachers and pupils. . . . The Southern list will be an honor list of schools for the entire section."

This commission was largely influenced as to formation and purposes by the North Central Association, so that "practically the same standards and units will be recognized by twenty-nine states, from Montana to Florida, and from Michigan to Texas."

It seems probable that the operations of the Board, either directly or by imitation, will ultimately embrace the whole territory of the Union, except possibly the North Atlantic states.

Of Western origin, the accrediting system, radically modified to be sure, found its way in the seventies into New England and the East, where it was ultimately adopted, at least in part, by all colleges except a few of the largest.

The two most fundamental modifications of the Western plan of accrediting as it developed in the East were: (1) Applicants were admitted to college on *certificate*, i.e. a statement made by a principal or a teacher. Graduation from and recommendation by a standardized secondary school was not required. (2) Schools were not inspected; information concerning them was obtained, if at all, mainly by correspondence.

By these two modifications were abrogated the most valuable characteristics of the original accrediting system. Consequently, while in the West, with its closer educational organization, the system grew constantly in favor, in the East, where educational individualism was more prevalent, it sank, under the pressure of college competition, to a very low degree of efficiency.

The very evils of the situation, however, together with a recognition of the evident advantages of accrediting when properly managed, led to a wide-reaching reform. This reform took shape in 1902, when there was organized in Boston, by delegates from certain colleges, the New England College Entrance Certificate Board. The organization was formed "for the purpose of receiving, examining, and acting upon all applications of schools that should ask for the privilege of certification."

The operations of the Board are confined to schools within New England. Its means of securing information concerning schools are mainly: (a) written information furnished by the school; (b) the scholarship records made in the colleges by "certified" representatives of the schools.

It should be noted that in marked contrast with the constitution of the Western accrediting commission this is

wholly a college organization; the schools have no representation on the Board and no voice in determining its policy. Moreover, there is no provision for visiting the schools by the college men, with the consequent better mutual understanding, which has proved so valuable a feature of the Western plan. There seems to be no attempt to cooperate with the schools with a view to helping to solve the ever more pressing problems of secondary education. The Board regards the schools only as factories for turning out college student material. Thus: "The ability of pupils to pursue their college work satisfactorily is the only evidence that the Board can consider sufficient to warrant approval of the school."

Among the most important rules of the Board governing the "certification" of schools are: (a) Schools must apply in writing and furnish detailed information upon blanks furnished by the Board concerning courses of study, teachers, and equipment. (b) A school must be able (1) to prepare for at least one college of the Association; (2) to show "by the record of its students already admitted to college [by examination] its ability to give thorough preparation for college." (c) Schools are approved for three years after one trial year.

Within its field and purpose, — to confine the issuance of certificates to worthy students and by responsible schools, and to establish the merits of the accrediting method of admitting to college, — the Board has been markedly successful. For when the Board was organized, there were five hundred and thirty-four New England schools on the approved lists of one or more of the ten colleges which had been receiving students by certificate; but the first year of the Board's operations it approved only one hundred and seven schools; and nine years later (1911), the approved list of schools numbered but three hundred and fifty-six. As to scholarship, in all the more recent reports of the Board are given extensive detailed comparisons of the relative standings of those students

who entered by the Board's certificate plan and those who entered by examination.

A few quotations from the Board's annual reports in order of publication will give the gist of the conclusions: "It appears from the tables that the per cent of failures among those who enter on certificate is much lower than among those who enter on examination." (Sixth annual report.) "The per cent of failures among those who enter on certificate continues much lower than among those who enter on examination." (Seventh annual report.) "From this it appears that the number of failures among those entering by examination is relatively half as many again as among those entering on certificate. This difference between the two classes persists from whatever point of view we regard the statistics." (Ninth annual report.)

TOPICS FOR FURTHER STUDY

1. What factors entered into the establishment and development of the high school system in your own state?
2. What relation exists or should exist between the high school and the elementary school in your own state?
3. Do better relations exist in other states?
4. What variations exist between the high schools of your state and of other states?
5. To what extent are the high schools of your state college preparatory schools and to what extent are they influenced or dominated by the colleges?
6. To what extent, as shown by statistical investigation and by curricula, are they finishing schools?
7. To what extent have they developed vocational characteristics?
8. What is the form of control exercised over the high schools? Can improvements be suggested?
9. To what extent does your own state have a rural high school system? What are its characteristic features and the form of control? How may these rural high schools be improved? How do the curricula differ from the schools of towns and cities?
10. How do the rural high schools of your state compare with those of other states?

11. Through what stages of financial support have the high schools of your state passed?

12. What is the basis of apportionment of funds to high schools in your state? What are the advantages and disadvantages of this system?

13. What system of inspection and accrediting of schools exists in your state? What are the advantages and disadvantages of this system as actually demonstrated?

14. What are the advantages and disadvantages from the point of view of the high school of the various methods of college entrance?

15. What are the advantages and disadvantages of a state system of inspection of high schools?

REFERENCES

BOLTON, F. E. Special State Aid to High Schools. *Educ. Rev.*, Vol. XXXI, pp. 141-166.

BROWN, E. E. *The Making of our Middle Schools*. New York, 1903.

BROWN, J. F. *The American High School*. New York, 1909.

CUBBERLEY, E. P. *School Funds and their Apportionment*, Ch. XIV. New York, 1905.

DAVENPORT, E. *Education for Efficiency*. Boston, 1909.

England, Board of Education. *Special Reports on Educational Subjects*, Vol. XI. *Education in the United States of America*. London, 1902.

HOLLISTER, H. A. *High School Administration*. Boston, 1909.

INGLIS, A. J. *Rise of the High School in Massachusetts*. New York, 1911.

JOHNSTON, C. H. *High School Education*. New York, 1912.

The Modern High School, its Administration and Extension. New York, 1914.

Proceedings of the Association of College and Preparatory Schools of the Middle States and Maryland.

Report of the Committee on Secondary School Studies, known as the Report of the Committee of Ten. (Appointed by the N. E. A. in July, 1892.)

SNYDER, E. R. *The Legal Status of Rural High Schools*. New York, 1909.

See also *Educational Review and School Review*.

CHAPTER V

THE ORGANIZATION OF THE HIGH SCHOOL

THE ADMINISTRATION OF THE HIGH SCHOOL DETERMINES ITS EFFICIENCY. — The administration of a high school is the enacting clause for the whole institution. It is the executive department that must make effective the legislation embodied in the curriculum. It is the clearing house that must adjust the relations of the various teachers and departments to each other and to the school as a whole. It is the personal equation between pupils and teachers and between school and home. It is the prime minister that must interpret popular needs to the people's legislators. Without efficient administration a million-dollar school plant may become the splendid mausoleum of the hopes and opportunities of youth and of the self-devotion of a faculty. With efficient administration a tumble-down brickery may become a temple of culture, service, and democracy.

The Principal is the Chief Factor in the Administration. — The principal must of course always be the chief administrative officer of a school. Good administration, however, means that he should not be a czar. Granted, for sake of argument, that he is the wisest and most capable person in the organization, he certainly is not wiser and more capable than himself plus his faculty, by axiom. The genius of American institutions is democratic, and if the American high school is to develop in harmony with this genius it must embody the essential elements of democracy.

Full Support of the Faculty Necessary for the Best Results.

— In small schools the teachers should all be advisers of the principal. Important measures should command that support from the entire faculty that can come only from free discussion and concurrent decision. In large schools that have departmental organization the heads of departments should form a cabinet that will give administrative measures the representative support and advice of the faculty. The department faculties will in turn discuss departmental matters as well as general administrative policies so that the democratic principle may be maintained throughout.

Neither faculty, cabinet, nor department should, however, degenerate into a mere debating or disputing society. The relation of the official head to any of these units must be that of any similar responsible officer in any executive body. He may veto a measure generally approved or he may order a course of action generally disapproved; but he will do neither of these things without the most deliberate consideration and the most weighty reasons. The principal who has the personality, judgment, and training demanded by his position will very seldom find it necessary to differ radically from the combined opinion of his advisers.

THE PROBLEM OF ADMINISTRATION. — Given, then, a more or less adequate high school building and equipment, the high school pupils of a community, a more or less adequate faculty; the first problem of the high school administrator is to furnish the necessary systematization of details to enable the teachers and pupils to work together to the best possible advantage.

The Course of Study. — Perhaps the first, as well as the most important, question to be considered is, what subjects shall be taught? The treatment of this topic in other chapters makes its discussion here unnecessary, yet the problem is so fundamental that certain aspects of it must necessarily creep into any consideration of the high school. On no other subject

are school men more likely to be dogmatic, and on none is there so great need of a careful, scientific study of facts as a basis for procedure. In determining the course of study for any given group of students, the needs of the community, the abilities and the social and industrial destinies of the pupils, and the limitations imposed by the financial means at the disposal of the school should be the deciding factors rather than traditions or *à priori* theories as to what constitutes "an education."

The school administrator of to-day must remember that the problem of secondary education has grown infinitely more complicated than it was when it was supposedly settled with such amazing finality by the Committee of Ten. The students outnumber those of twenty years ago by about four to one. Congestion of population in the cities has brought with it social problems undreamed of two decades ago. The perfection of machinery has revolutionized industry within that time. Organized society as represented by municipality, state, and nation has been compelled to assert the rights of the social whole in an infinite variety of relations at that time only dimly apprehended. Then we believed that our natural resources were inexhaustible; to-day we know that the rights of succeeding generations demand wise conservation. Then we ignored political corruption, especially in our cities; now we recognize in the conspiracies of machine politics and unscrupulous business a challenge against the life of our democracy. We have come to see that every economic question is fundamentally a moral and spiritual question. So child labor, a living wage, safe and sanitary working conditions, public health, infant mortality, the liquor problem, are all recognized as the business of every good citizen.

The public school is the one completely socialized agency for the improvement of society. The public high school is, at present, the most advanced part of this institution. From its product will come the vast majority of to-morrow's leaders.

Obviously those charged with its administration must not content themselves with pharisaical platitudes about culture and discipline in place of open-minded response to obvious public needs. The awakened social consciousness of the school administrator will furnish guidance in almost every problem that arises in his day's work. It will make him question all the traditions of his craft, and if his attitude of mind is backed by a powerful personality, such a principal will completely transform the spirit of any high school whose ideal has been the increase of the sum total of knowledge of Latin and algebra.

THE DAILY ROSTER FOR PROMOTION BY SUBJECT. — After the course of study has been determined, the next problem is the making of the daily roster. Under the system of promotion by grades this was a comparatively simple task. Pupils were platooned into approximately equal groups and moved in mass. Unfortunately this procedure made it necessary for a pupil failing in one or two subjects to repeat all others, no matter how well they had been mastered, or else to go ahead with his group when certain subjects had been so poorly learned as to make further progress impossible. A third evil, fully as great, although less apparent, was that it made consideration of the individual needs of pupils practically impossible. Even in the higher grammar grades this system is now being abandoned in many progressive schools, and in high schools it is tolerated in only a few communities.

Making the roster for promotion by subjects is the most complicated task in the organization of a high school. Strange as it may seem, the real difficulties become fewer, the larger the school. This is true because in a larger school there will be two or more classes in nearly every subject. Therefore, the pupil who has in his roster a conflict with one period of a certain subject will be able to recite another period. The longer the school day, the fewer will be the number of conflicts, because each pupil will have more vacant periods. It

is only because of their longer school day that small schools can make successful rosters for promotion by subjects.

Data Necessary as a Working Basis. — The first step in making a roster is to determine the number of pupils likely to require each subject to be offered. This can be ascertained during the latter part of the term from some such card as the one shown opposite. If the reports were sent out monthly, of course additional columns like those designated "*Marks*" would be required. After the next to the last report of the term it is possible in the majority of cases to estimate with a fair degree of accuracy the prospects of passing or failure for each pupil in every subject. The experience of the school as to percentage of passing in each subject furnishes a valuable check on this estimate. From the estimate of numbers based on a count of "Subjects next term," with due allowances for failures, the number of classes in each subject can be determined.

The figure opposite shows the organization card of the William Penn high school, Philadelphia. Early in the term the heading, and the data under "Studies This Term" are filled out by the pupils, "Hrs." shows the number of recitations per week, and the check mark in column "R" shows what the pupil is repeating, D Geometry, for example, on this card. At report time teachers put in marks and their own initials. The column "Studies Next Term" is filled in by the counts before the final mark is entered. They are required to follow the course of study in choice of studies for "next term" unless a change is authorized by the principal. The "Record Teacher" is responsible for seeing that the course of study is followed, that subjects failed are included in next term's list, that counts are entered in the first column at the left, and that the pupil is correctly graded for the coming term. The "Record Teacher's" name at the upper right-hand corner indicates that she has passed the card as correct in all details. The daily roster for next term is then entered by the organization committee. The number above the faint line in each case indicates the room in which the class is held. "400" is the study hall, and the letter and figure in the space below indicate the pupil's seat for the period. This item is not entered until the beginning of "next term," when a committee of the Student's Association seats the pupils in strictly alphabetical order. The first day of "next term" the pupil makes a copy of her roster from the bottom of this card and the organization card is returned to the office. This is the card of an irregular pupil who had deferred Latin for one term so as to make up geometry.

The Organization of the High School 179

"RECORD TEACHER," *A. E. Hall.*

Grade *C.* Bk. *21.* Fall 1914.

Surname First _____

Telephone _____ Entered _____ 191__

Address _____

Col. Prep. Course. College or Normal? Swarthmore. C's 60.

	CLASS	STUDIES THIS TERM	HRS. R?	TR'S INITIALS	MARKS	CLASS	STUDIES NEXT TERM	HRS.
<i>2</i>	<i>C</i>	<i>English</i>	<i>4</i>	<i>A. B. C.</i>	<i>C B B</i>	<i>B</i>	<i>English</i>	<i>4</i>
<i>2 1/2</i>	<i>D</i>	<i>Geometry</i>	<i>5</i> ✓	<i>A. S. L.</i>	<i>C C C</i>	<i>C</i>	<i>Geometry</i>	<i>5</i>
<i>2 1/2</i>	<i>C</i>	<i>German</i>	<i>5</i>	<i>E. R. C.</i>	<i>C B C</i>	<i>C</i>	<i>Latin</i>	<i>5</i>
<i>-</i>	<i>C</i>	<i>Physics</i>	<i>5</i>	<i>H. A. R.</i>	<i>D D C</i>	<i>C</i>	<i>Physics</i>	<i>5</i>
<i>1/2</i>	<i>C</i>	<i>Drawing</i>	<i>2</i>	<i>O. R. H.</i>	<i>B C B</i>	<i>B</i>	<i>Drawing</i>	<i>2</i>
<i>1/2</i>	<i>C</i>	<i>Phys. Tr'g.</i>	<i>2</i>	<i>A. L. C.</i>	<i>- B B</i>	<i>B</i>	<i>Phys. Tr'g.</i>	<i>2</i>
<i>1/4</i>	<i>C</i>	<i>Music</i>	<i>1</i>	<i>M. R. S.</i>	<i>- B B</i>	<i>B</i>	<i>Music</i>	<i>1</i>
<i>8 1/4</i>							<i>Total</i>	<i>24</i>

Counts earned this term ? *8 1/4.* Grade next term ? *C + 8 1/4.*

	MONDAY	TUESDAY	WEDNESDAY	THURSDAY	FRIDAY
<i>1</i>	<i>322</i>	<i>322</i>	<i>322</i>	<i>322</i>	<i>302</i>
	<i>C Physics</i>	<i>C Physics</i>	<i>C Physics</i>	<i>C Physics</i>	<i>B Drawing</i>
<i>2</i>	<i>322</i>	<i>Gym.</i>	<i>400</i>	<i>Gym.</i>	<i>302</i>
	<i>C Physics</i>	<i>Phys. Tr.</i>	<i>H-25</i>	<i>Phys. Tr.</i>	<i>B Drawing</i>
<i>3</i>	<i>105</i>	<i>105</i>	<i>105</i>	<i>105</i>	<i>105</i>
	<i>C Geom.</i>	<i>C Geom.</i>	<i>C Geom.</i>	<i>C Geom.</i>	<i>C Geom.</i>
<i>4</i>	<i>100</i>	<i>400</i>	<i>400</i>	<i>400</i>	<i>400</i>
	<i>B Music</i>	<i>L-5</i>	<i>K-3</i>	<i>H-15</i>	<i>R-27</i>
<i>5</i>	<i>400</i>	<i>217</i>	<i>217</i>	<i>217</i>	<i>217</i>
	<i>K-3</i>	<i>B English</i>	<i>B English</i>	<i>B English</i>	<i>B English</i>
<i>6</i>	<i>125</i>	<i>125</i>	<i>125</i>	<i>125</i>	<i>125</i>
	<i>C Latin</i>	<i>C Latin</i>	<i>C Latin</i>	<i>C Latin</i>	<i>C Latin</i>

Non-conflicting Term Units are Necessary. — Then some system of non-conflicting periods must be provided.¹ The simplest is to make the division by daily periods straight through the week as shown on the bottom of the foregoing organization card.

Regular and Irregular Students. — Next the subjects can be placed on the roster. The first consideration, of course, is to arrange so that a pupil taking the regular work of any course shall be able to make his roster. Then provision must be made for a pupil failing in one or in two subjects to repeat the subjects failed. Usually it is comparatively easy to tell where the failures are most likely to occur. For example, in the first term the majority of failures will be in foreign language and Algebra. Therefore, the roster should provide amply for pupils who have failed in one of these subjects or in both to go ahead with the subjects they have passed.

Double Periods. — The *bête noir* of the roster maker is the double period. Science teachers always insist that they cannot do their work without double periods for the laboratory. It is obvious also that cooking cannot be successfully taught in a forty-five minute period. In many other subjects, including all forms of manual training and shop work, double periods at least a part of the time can be successfully used. Some of the difficulties with double periods can be overcome by combining two subjects in the same course so that their time fits together. For example, if physics recites the first period the first four days of the week and doubles to cover the first and second Monday, any subject of the same term which recites four times a week can be placed in the second period for the last four days, or such a combination can be made as is shown on the bottom of the organization card (page 179). When there are many subjects requiring double

¹ In an article, "Making a High School Program," in the *School Review*, September, 1909, Myron M. Richardson describes a system of rotating the daily periods.

periods there should be a secondary non-conflicting arrangement. For example, the first and second, the third and fourth, and the fifth and sixth periods should be grouped together, and no combination should be permitted across the dividing lines, such as running a class from the second into the third, or from the fourth into the fifth, period.

	MONDAY	TUESDAY	WEDNESDAY	THURSDAY	FRIDAY
1	1	1	1	1	4
2	1	1	1	1	4
3	4	2	2	2	2
4	4	2	2	2	2
5	3	3	4	3	3
6	3	3	4	3	3
7		4		4	

An ingenious combination of four non-conflicting double-period groups is used in some schools as indicated in the table above. The ordinary pupil will have at least two or three subjects that do not require double periods. If the curriculum is based on a four-period-per-week unit, at least two of these can be placed in one of the blocks, for example in the one marked 1. Then the double-period subjects can be arranged in the three remaining blocks with less likelihood of conflict. This device calls for a seven-period day. It also provides three periods per week, namely, the seventh on Monday, Wednesday, and Friday, when there are no classes. Of course a rearrangement of the periods would place these general periods wherever in the week they were desired. The value of such periods will be immediately evident to any administrator. It will be possible at that time for any teacher to

meet any pupil or any group of pupils in the school. Lectures and other outside attractions can be brought in at that time without disturbing the regular work. High school dramatics, student government activities, and any other desirable feature involving the whole or a part of the student body can be placed in those periods.

Advantages of a Regular Roster Maker. — The variety of schemes of roster making by different schools is almost infinite, but the fundamentals enumerated above are practically uniform. In a small school it becomes necessary to make a tabulated list of all pupils, particularly of those in the higher classes, and to plan the roster so as to provide for individual exigencies. Indeed the problem presents infinite varieties of form in different schools. Fortunately there are many ways around difficulties that to the uninitiated would seem unsurmountable. These can, however, be learned only by experience. The making of the roster presents a difficult problem in permutations, but it is fundamental. In the largest schools the principal may delegate it to a teacher who has particular aptness for such tasks, making due allowance in his or her teaching assignments. This is probably the best way out of the difficulty, as the regular roster maker soon acquires great skill in manipulating the details. After a few reorganizations he will develop a roster that, with comparatively slight changes, will remain permanent from term to term. However it may ultimately be managed, intimate acquaintance with this roster problem is an absolute essential in the equipment of a high school administrator.

ASSIGNMENT OF WORK TO TEACHERS. — Along with the arrangement of the various classes on the roster must go of course the assignment of work to teachers. The number of periods and the number of different subjects allotted to each teacher varies widely. In the smaller schools the requirement is so high, both in teaching hours and in variety of work, that satisfactory work is impossible. The report on Educa-

tion in Vermont, issued by the Carnegie Foundation, discusses a situation that is more or less common throughout the country.

The Number of Periods required a Week from each Teacher. — “A table in Part III¹ gives the average number of class recitations per week taught by the full-time teachers in each school. The limits within which a teacher may be expected to do a high grade of work naturally vary with the character of the subjects taught, the amount of special preparation necessary, the quantity of written work to be reviewed and corrected, and the number of individual problems, the amount of bookkeeping, and the strain of class attention which the size of the class involves. It is generally agreed, however, that, with a normal class membership of 20 to 25, no teacher can hope to give successful secondary instruction with a program of more than 25 class periods per week, and 20 is much better. For teachers of English under present methods even this latter number should be reduced. Beyond 25 periods, quality deteriorates rapidly and gives place to the merest hack work, however well meant. It is assumed, furthermore, in setting up this maximum, that a teacher is teaching one or two groups of subjects for which he has had special preparation. Three classes of Latin and two of German constitute a program preferable in all respects to five classes of Latin; but good work cannot be done with a program made up of senior Latin, junior physics, second-year history, first-year English, and algebra. It is only necessary to glance at the table mentioned to see how Vermont high school requirements compare with this standard; 60 of the 77 schools are burdening their teachers with an amount and variety of work which makes excellence impossible. Unfortunately, a low quality of teaching is not readily detected by the lay mind, and under such conditions formalism, cant, and ignorance are likely to overcome the best intentions.”

¹ This table shows that teachers in Vermont high schools teach from 28 to 48 periods per week.

Special Duties. — It will be found advisable in a large school to make allowances on the teaching roster for various special duties as well as for peculiar conditions in the work of certain subjects. The necessity of thorough correction of themes and personal conferences with pupils in English is generally coming to be recognized as sufficient reason for a somewhat lower requirement in teaching hours in this subject. On the other hand, subjects like sewing, cooking, manual training, and drawing, which call for less outside preparation, may fairly permit a somewhat larger requirement in actual teaching hours. In a large school certain administrative duties must be delegated to teachers if the principal is to be free to use his time to the best advantage in furthering the growth of his school along the broader lines. A city school, for example, needs a vocational bureau that will study the opportunities of employment and make known to pupils something of their scope. This bureau should also have charge of the placement of graduates and of the part-time placement of pupils who would be compelled to leave school if some means of earning money could not be secured. The supervision of student activities is another function that requires much special attention. Teachers who assume such important duties as this should not be required to carry full teaching rosters.

THE PRINCIPAL'S RELATION TO THE VARIOUS ACTIVITIES OF THE SCHOOL. — The principal must be kept in touch with all of these activities of his school by frequent conferences with the teachers in charge of them. He should show his vital interest by visits to the various groups of students. He should have a clear and definite idea of the place of every activity in the life of the school, and he should of course exercise the greatest care in selecting faculty sponsors. No greater mistake can be made, however, than for him to think that he is the only person in the school capable of developing a line of action. The oft-quoted dictum of

Miles Standish must be radically amended by any manager of a large and complicated organization whether of school or of business. It should be revised so as to read, — “If you would have a thing well done, select the right person to do it, keep your hands off, and require results.” This is the principle of functional management that has played so large a part in the scientific management successes of Frederick W. Taylor and his disciples. It is very generally applied in business, but it is often ignored in school management. The principal who feels it necessary to answer minute questions and follow up all the petty details of a large school will find it absolutely impossible to extend his vision beyond the pin-points to which he is devoting his energy: Moreover, he will neither utilize to the best advantage the various abilities of his teachers nor develop their individuality and initiative. In this way his school will be the loser, for he must be a rare leader who can do each of the various kinds of task involved in the management of a great school better than any one of the dozen or hundred people in his faculty.

The attitude of mind of the principal on this particular point is much more vital than might be seen at first. A teacher to whom a task is given only with minute directions for every detail naturally refuses to assume full responsibility for results. If the principal habitually withholds or refuses freedom to members of his faculty to work out in their own way the problems he assigns to them, they soon come to look upon the administration as none of their affair, and confine their efforts as nearly as possible inside the walls of their classrooms. Unless suggestions and criticisms are welcomed, the breach between administration and instruction is widened. Perhaps worst of all, the spirit of the school develops into a wooden response to authority without that desire for coöperation for the general good that is essential to the largest service of the institution that is forming the subconscious basis of the citizenship of to-morrow.

RELATION BETWEEN THE GRAMMAR SCHOOL AND THE HIGH SCHOOL. — Some of the most vexatious problems in high school administration are found in the relations of the school with the educational institutions below and above it. The difficulty of articulation with the college has been the subject of a long and bitter controversy. The need of better articulation with the elementary school is now claiming serious study. In the small towns where all of the educational facilities are supervised by one principal this adjustment offers little difficulty. Generally speaking, it becomes more and more of a problem the larger the city. In many cities the authority of the superintendent of schools over the high schools is vague and uncertain, and the direct coöperation between the grammar and high schools almost nil. The entire reorganization of the twelve years of the public school into a six-year elementary school and either a six-year high school or a junior and a senior high school of three years each is doubtless the best solution of the problem of articulation between the elementary and the secondary school. The tendency towards this change seems to be rapid, but its prospect should not keep other efforts at coördination from being made.

Coöperation between the High School Principal and the Grammar School Principal. — The most obvious point of contact is between the high school and the grammar school principal. A mutual understanding here will be of great advantage to the pupils. The grammar school principal should visit the high school, go into the classes where his former pupils are working, learn the meaning of the high school opportunities available for his pupils, and give much personal attention to the selection of courses by individuals before they enter. It is needless to say that his advice and counsel should be welcomed by the high school principal. Individual peculiarities that seem inexplicable are often explained by the closer personal knowledge of the workers in

the lower school. Not infrequently the grammar school principal can throw some most illuminating sidelights on the high school. His boys and girls are sure to go back to him, particularly during their first term, with interesting comments on things "at high." Weaknesses immediately evident to their keen eyes are analyzed with all the intolerance of youth, and usually with surprising accuracy. The high school principal whose mind is open to possibilities of improvement in his own school will cordially welcome the suggestions and criticisms that he can never hear save through his confrère in the lower school.

Visits and Reports between the Schools.—Nor should the grammar school principal do all of the visiting. The high school principal who has never visited the grammar schools of his district will be surprised at the good results of systematic visits to those who are preparing his raw material. He will be much less likely to blame the lower school for the obvious shortcomings of its product after he has visited its classes and come into personal contact with its problems. The pupils who are to go to the high school will feel that they have a friend in their new principal if he has visited them in their earlier habitat. This sense of familiarity will impart a confidence that can be developed only after much longer contact within the high school itself. It is perhaps one of the surest ways to guard against the terrific loss during the first term of high school. If the principal has the confidence of the pupils, which he can get better from even a slight previous acquaintance, he can more effectually guard them against the danger of losing step with the procession during their first month or two in the new and strange environment.

The grammar school and the high school are owned and financed by the same public; they are working with the same boys and girls for the same ends. Each has a point of view different from the other; each has information that would

be valuable to the other. Neither can do its best work until it is brought into the most harmonious coöperation with the other. Very naturally the grammar school expects the high school to take the initiative in establishing the most cordial relations. The high school should profit by its own trials in dealing with the few colleges that stand aloof in their dignified pedantry, and lead the way in establishing the most friendly coöperation with the grammar school.

RELATION BETWEEN THE HIGH SCHOOLS AND THE COLLEGES. — Relations between the high school and the college are happily becoming better. Much remains to be done before they are satisfactory, but the fine spirit of a few of the greatest institutions of higher education is making it possible for any pupil properly prepared to profit by college advantages. The evil within the high school of a curriculum based on college preparatory ideals is one that for many years to come will continue to limit its service. The petty demands of some institutions, particularly of the women's colleges of the East, will suggest to progressive principals the desirability of absent treatment. The whole question, however, is one in which the individual principal is so well-nigh helpless that he can have little hope for improvement in conditions save from the national commission that is endeavoring to bring about more satisfactory relations.¹

DISCIPLINE. Successful Discipline depends on Understanding the Adolescent. — By no single criterion is the efficiency of school administration more frequently judged than by its discipline. Like the social worker the good disciplinarian aims at the prevention rather than the cure of evil. The secret of preventing the necessity of discipline lies in building up the right spirit in the school. To do this in a high school demands a sympathetic understanding of

¹ The present writer has discussed the evils of college domination of the high schools in *Democracy's High School*, Educational Monograph Series, Houghton Mifflin & Co.

the peculiarities of the adolescent. The appeals of previous years are no longer efficacious. Insistence upon orders as such only arouses antagonism. The adolescent wants to see the reason for the rules and directions given, he wishes to feel himself part of a coöperating group. He is profoundly sensitive to public opinion. Hence he will usually join enthusiastically in any scheme that asks his help in doing the things that are clearly for the benefit of all concerned. If, on the other hand, the sentiment of the school favors disorder and lionizes the wrongdoer, the discipline becomes a pitched battle between the administration and the student body.

Public Sentiment of the School the most Important Factor. — It makes little difference what system is used so long as it enlists genuine coöperation on the part of the students. A so-called self-government scheme has no merits that will solve the problem of discipline if the spirit of the school is not right. Elaborate organizations of a legislative or judicial character are of questionable value. The one essential is the development of an enthusiastic loyalty to the best interests of the school that will express an unequivocal disapproval of anything harmful to its welfare.

In securing this spirit the administration should never abrogate its rightful authority. It is justly held responsible to the community for satisfactory results, and it cannot secure these unless its decisions are final. Moreover, the loss of a wholesome respect for this authority on the part of the student body is absolutely fatal. The autocratic rule of a martinet is much more conducive to wholesome school work than the loose and vacillating government of a principal whose authority the pupils do not respect. Schemes of self-government in a weakling's hands speedily become a huge joke, and the discipline becomes a school of petty politics.

Gradual Introduction of Student Participation in School Government. — Beginning, however, with a school well in hand, it is comparatively easy to introduce student partici-

pation in the responsibilities of discipline. The habitual appeal to the better instincts of a class when a teacher is absent is one easy approach that is familiar to all. The appointment of a student who is a real leader to take charge of the assembly or to arrange certain details for graduation or for a school function, or an invitation to students by classes or groups to elect representatives to cooperate with the faculty for certain ends will prepare the way for the gradual assumption of certain functions of discipline by the students. The moment that some of these cooperative activities are successful is the one for further extension of the plan. "We have succeeded in this. Can we do the next thing?" Such an appeal is sure of a hearty and genuine response. "Is it safe for the school to remove teachers from police duty in corridors, lunch room, assembly, and study hall?" Any student body that is permeated by a wholesome community spirit will instantly assure the principal that it is. This does not mean that all of these responsibilities should be thrown upon the pupils at once, nor that the principal should start such a system and then leave it to run itself. A much better plan would be to take one problem, for example the lunch room, and see how well the students can manage it. "Men and women are accustomed to eat without police surveillance. Eating is a social function, where we meet our friends without restraint. Suppose we as a school assume full responsibility for the order in the lunch room and for the appearance of the room after we have finished." When one such responsibility is satisfactorily met, another should be assumed if possible. The spirit of cooperation, like a muscle, gains strength by exercise. The power of public opinion is much more compelling than any rules that can be made. If the sentiment of the school is overwhelmingly in favor of right action, there are few boys or girls who will stand against it.

Nothing does more to focalize this wholesome public sentiment than a sense of students and faculty working together

for a common end. As the student government develops, a representative organization becomes necessary. Problems of evident importance to the school should be freely discussed by this body, and there should be ample opportunity for the representatives to carry back to their respective groups the ideas of the central body. The attitude of mind that sets a whole student body to discussing such a problem as "how can we eliminate unnecessary tardiness," is in itself most wholesome and will go far toward securing the desired result.

Social and Political Reasons for Student Participation in School Government. — An experience in a school where the coöperation of the students has been successfully enlisted illustrates the effectiveness of their assistance. The manners of the pupils at the daily assembly in this school had become so careless that the principal announced one Thursday morning that the school would meet in the hall at the close of school on the following Monday to practice for the assembly. The officers of the Student's Association took the matter up that day with each group in the study hall where pupils not in recitation were seated. On Friday and Monday mornings the assembly manners were perfect. The president of the Student's Association spoke for the student body Monday morning and requested the principal to postpone the rehearsal that he had announced. She requested that the students be given an opportunity to show that they could improve their behavior without any artificial means being employed to remind them of the proprieties of the assembly. Of course, the principal granted the request.

In this school the study hall in which from 250 to 400 pupils are seated all the time is conducted entirely by the students. One teacher who has peculiar fitness for the task has full supervision of this and all other student activities. She is not required to do any teaching, but even at that a considerable saving is effected, as the study hall alone formerly re-

quired the constant supervision of two teachers. Not only these two teachers but all others as well are now released from police duty, and the spirit of the school is greatly improved as a result of the absence of a jarring relation between teachers and pupils.

It hardly needs to be said that the improvement of the behavior and the solution of problems of discipline are not the chief reasons for enlisting the aid of students in the discipline of the school. A recognition of the school as a social institution forming the habits of social thought of its young citizens will furnish ample reason for developing in them the habit of coöperation. If they were citizens of a despotism, they should be governed by a despot in order that they might develop the habit of immediate and unquestioning obedience. Inasmuch as they are citizens of a republic that depends for its success upon the thoughtful coöperation of its citizens it seems clear that in the school where they have an unquestioned community interest they should acquire the habit of thinking in terms of community welfare.

Athletics, dramatics, the school paper, clubs devoted to certain studies or interests, all form a point of contact for student and faculty coöperation. One reason why the athletics present such a vexatious problem in many a school is that the school is run as a despotism and the athletics as more or less of a democracy. The two spirits do not mix, and the school has something of the same sort of troubles that arise when primitive peoples who have not learned to assume the responsibilities of democracy attempt to form a democratic government. More democracy may not be the cure for the evils of so-called democracy in Mexico and China, but in the public high school of an American town where the government of the city, the state, and the nation are democratic, where the social traditions for centuries past are democratic, it would seem that a properly guided democracy is the natural and the appropriate form of government.

HUMANIZING THE SCHOOL.— A democratic spirit that secures the interest and coöperation of the students will go far toward humanizing the school. In our large city schools it is often extremely difficult to avoid so much system that the whole school becomes mechanical. The necessity of impartiality leads to the statement of definite rules whose invariable application often works needless hardship. "Up-holding the standard" ¹ easily becomes the fetish of a small mind, and the application of a rule or a precedent is an easy way out of a difficulty for an administrator of the martinet type. In a large city school the principal cannot possibly know personally any considerable proportion of his students. Home conditions, financial limitations, special abilities and blind spots, ambitions, vocation opportunities, — these and many other considerations demand individual treatment if the school is to educate individuals as they are instead of educating the "average" boy or girl, who of course does not exist. Then there is the longing for sympathetic understanding and for the counsel of older people that gives the teacher of the adolescent his greatest opportunity. The organization of the high school whereby a pupil recites to four or five different teachers every term and possibly to an entirely different group the next term or year makes it very difficult to humanize a large school so as to meet these evident needs.

Student Advisor System.— Any system of advisorship is open to the objection of mechanizing a function that in its very nature is intimately personal, but in the large school such a system, plus those individual confidences that are sure to grow up in a more or less haphazard way, is better than the chance adjustments alone. In these important relationships that often mean much more to the pupil than any or all of his studies, the spirit of the school is the most important single factor. Nearly all teachers are glad of an opportunity to give themselves to their pupils. Where the

¹ See "The Worship of the Standard," W. H. Mearns, Proc. N. E. A., 1912.

spirit is right, pupils respond cordially to the helpful attitude of the teachers. A sour, censorious spirit on the part of the administrator, however, is sure to spoil the good fellowship between pupils and faculty that might be the most potent influence for good in real education of his pupils.¹

ADAPTING THE SCHOOL TO COMMUNITY NEEDS.

— The administration of a high school must keep the school growing along all the lines in which it can be of service to its pupils and its community. It is precisely because the vast majority of high school administrators have failed at this point that there has been so violent an outcry from shrewd observers within the last few years. The high school has been following the traditions it inherited from the English so-called public school, which, of course, is not a public school at all, until it is being jolted into an awakening to its democratic obligation to the community that is paying its bills. So the tendency to-day is strongly toward a broadened curriculum and a more liberal administration of the curriculum that shall enable the school to give the various kinds of training that its largely increased clientage demands.

The Changed Problem. — It is needless to do more than mention the changed conditions that have brought about the tremendous change in the problem of the high school. When it first grew out of the old academy, its chief service was the secondary training of those who were to enter the professions. The toilers gained the mysteries of their various crafts from their immediate environment. The little red schoolhouse taught the rudiments, and only the more fortunate of the future farmers, mechanics, artisans, and tradesmen had a year or so at the academy or high school. Nearly everybody believed, as did the Committee of Ten as late as 1894, that the best education for the college-bound youth was the best for everybody. So the whole problem was simple. The revolu-

¹ See "Advisory Systems in High Schools," J. W. Raymer, *Ed. Rev.*, December, 1912.

tion in our industry and in our living conditions has now brought the high school face to face with the problem of providing secondary training for everybody. The real leaders of our educational policy see this clearly, and the administrators of high schools must work out the problem or go the way of the discards of the craft into truck farming and the vending of life insurance.

Study of Conditions Essential as a Basis for Change in Procedure.—This is the day of surveys. As never before, changes in procedure are based upon a careful study of conditions. So the high school should base its adjustment to the demands of its community upon accurate data rather than upon general theories. There are certain constants such as proper attention to physical needs, training in the use of the mother tongue, and in the fundamentals of citizenship, about which there is no dispute. Beyond these the school must be in a continual process of adjustment based on a study, first, of its students, and, second, of the community it serves.

It would be comparatively easy to describe certain types of pupils that are found in every high school. The studious boy or girl finds ample provision in our present academic régime. The motor-minded youths with infinite varieties of instincts, ambitions, and possibilities are the ones who present the serious problem. The coming of the vocational counselor will help to determine what the school can do for them. Minute discussion of details under this topic would be out of place. The emphasis needs to be laid, however, on the duty of the high school administration to study this problem from the point of view of its pupils.

The Community Element.—The study of the other element in the problem—the community—has many aspects. Americans so easily move from place to place that the immediate environment is no bar to the vocational aspirations of any boy or girl. Financial limitations, however, will often make it necessary to determine which of several types of train-

ing any given school shall afford. Superintendent Spaulding, formerly of Newton, Massachusetts, has given some most valuable suggestions¹ of methods of approaching this problem. Among other things he shows the relative success in the high school of the pupils from the various grammar schools, the cost of instruction in various subjects, the comparative number of pupils receiving training in various lines, and the distribution of workers in the principal skilled industries of Boston as shown by the last census. In discussing the problem of adjusting education to society's need of service he says:

"Just what we mean by preparing adequately our secondary school pupils as a whole to meet the wide range of legitimate service that society is demanding of the oncoming generation can be shown more clearly if we direct our attention to a limited portion of the field of secondary education and to a few types of service that society demands. In the Newton Vocational School the boys are learning certain trades, known as machine-shop, pattern-making, electrical, cabinet-making, and printing. The proportionate distribution of the total number of boys in the school among these several trades is represented by the solid black bars on Chart IX. These bars are drawn on the scale of one hundred; that is, the total of the four bars equals 100 per cent, or the total number of boys in the school; of these 44 per cent are learning machine-shop and pattern-making trades, 25 per cent electrical trades, and so on.

"Similarly there is represented on this chart by crossed bars the distribution of workers in the principal skilled industries of Boston as shown by the last census; for example, the chart shows that 30 per cent of such workers are engaged in the metal trades and 27 per cent in printing and publishing. Note that each school trade is represented on the chart immediately above that actual trade for which the school trade is preparing its pupils.

"This chart is of no value in itself; it has been prepared and is presented solely to show the type of chart, or charts, that both the educational and industrial, also the commercial

¹ *Education*, December, 1913.

and professional, worlds need. Similar to this chart, there should be constructed a chart, or rather a series of charts, based on adequate data, that would show, on the one hand, the proportionate distribution of workers engaged in industrial, commercial, and professional pursuits, and, on the other hand,

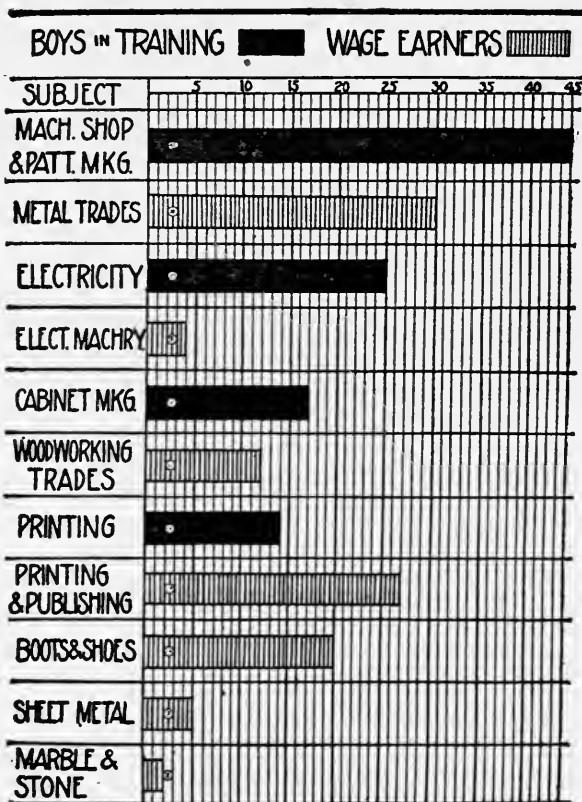

the proportionate distribution of pupils, including those in private as well as those in public institutions, among various courses of training that definitely prepare for different types of service. Such charts should include the data gathered from a large area ; all New England would not be too large an

area, anything less than the state would be too small, for the output of any school may easily adjust itself to the demands for service in a region extending far beyond the limits of the community, even though that community be a large city, in which the school is located.

“It would be highly desirable to have a series of charts of this type national in their scope, and also a considerable number of series, each covering a section of country somewhat unified from the industrial and commercial standpoint; state charts would serve fairly well if all states, or all states in a unified section, were charted.

“Just how could such charts be used to advantage? Let us illustrate concretely with this chart. Suppose this chart represented conditions in the skilled industries and in the trade schools of all kinds, not of Boston and Newton, but of all New England. It would show to the trade schools throughout that region that training for the metal and wood-working trades was being relatively overdone, that training for the electrical trades was being enormously overdone, that training for printing and publishing was underdone, while no training at all was being provided for the remaining trades, boot and shoe, sheet metal, and marble and stone. It would then be incumbent on the schools to bring about a different distribution among their pupils just entering on their training, discouraging entrance on trades likely to be oversupplied, and encouraging entrance on trades likely to be undersupplied with workers, perhaps establishing new courses of training in order to turn out a skilled product capable of rendering the greatest service.

“It is scarcely necessary to say that the value of these charts, to be used in this way, would depend on their up-to-dateness. In their educational features they should be revised every year, for the effort of many schools to adjust their training to the demands for service might, if long unchecked, result in a maladjustment as bad as that which they had sought to correct; for example, noting one year that training for electrical trades was being greatly overdone, while that for printing and publishing was being underdone, the correction of this maladjustment might soon result in a reversal of these conditions. In their industrial, commercial, and professional features, these

charts should be revised as often as the necessary data become available.

"If the state and the nation are really in earnest about vocational education and vocational guidance, the incalculable value of charts like these, both to education and to industrial, commercial, and professional interests, becomes at once apparent."

One of the most interesting features of Superintendent Spaulding's study deals with the purchasing power of a dollar as expressed in the number of pupil-hours of recitation it would buy. He discovered that a dollar bought 5.9 pupil-hours recitations in Greek, 23.8 in French, 19.2 in English, 41.7 in vocal music. Here is an interesting commentary on the moot question of educational values. Every school administrator is obliged to think of the financial aspects of his problem, and doubtless many will agree with Superintendent Spaulding when he says: "I was convinced, by very concrete and quite local considerations, that when the obligations of the past year expired, we ought to purchase no more Greek instruction at 5.9 pupil-recitations for a dollar. So this year, for the first time in the history of the Newton high school, we are buying no Greek; until last year's price can be materially reduced, we shall continue to invest in other subjects."

The Coöperation of Industry Necessary to the Full-est Service of the Secondary School.—It may be objected that this view of the problem contemplates no distinction between the high school and the trade school. The obvious answer is that if the public is to provide for the secondary education of all of its children, it must of necessity include the elements of the various lines of activity required by any proportionately large number of pupils. If it is to require school attendance to the age of sixteen, as now seems probable, it must recognize the various types of mind that become evident during the first half of adolescence. In this

extension of the scope of the school, industry must cooperate. Such schemes as the half-time plan at the University of Cincinnati and the schools of Fitchburg, Massachusetts, will doubtless play an increasingly large part in this readjustment.

This Broader Service demands Open-mindedness of the Principal. — In this broader service the administration will find numerous opportunities. Every school tries to keep track of the progress of its individual pupils term by term. Every teacher is in some sense a personal and vocational adviser. What is to be done with the pupil whom the course he is taking fails to reach? To fail at this point is to fail in the most important single duty of a principal. The distinguished success of a few pupils in college becomes a reproach upon a public school that can show nothing but ignominious dismissal or crowding out for pupils of a different type. The principal who year after year permits teachers to fail from 20 to 40 per cent of their pupils would speedily walk the streets in search of a job if, as superintendent of a manufacturing plant, he were throwing into the scrap heap a similar percentage of his raw material.

This larger adjustment of the school to the needs of its pupils and to the broader service of the community will not be performed without the principal's leadership. Once the spirit of social service is developed in a school, there will not be lacking a wealth of suggestion and self-devotion on the part of the faculty. Leadership, however, it must have, and leadership it cannot receive from the rightful leader unless his conception of the place of the school in society is broadened by a vision that reaches far beyond the traditions of mere inculcation of knowledge.

So the progressive administrator will not display the dogmatic hostility to innovations that too often characterizes the schoolman who has passed his fortieth birthday. Such suggestions as Commissioner Claxton has recently made¹

¹ *School Review*, March, 1914.

of a longer school day and a longer school year; the sixty-minute period, half of which is given to preparation of the lesson; the vocational guidance scheme of Principal Davis of Grand Rapids, Michigan; the Gary scheme, the six-and-six plan; part-time classes, — all these will be given thoughtful and sympathetic consideration. Probably none of them will be adopted entire. Few will fail to furnish suggestions that can be adapted to local conditions.

THE PRINCIPAL AND THE TEACHER. — As is the principal, so is the school. The spirit of his administration is sure to be reflected by both faculty and students. A heavy responsibility of leadership rests upon him, and with it splendid possibilities of service. His relationship with his faculty will not end with organization and discipline, but will be felt in every classroom if the school is not too large. It stands to reason that he can seldom lay claim to scholarship in all the lines of study in the curriculum. If he is wise, he will be very modest in asserting himself along purely scholarly lines, because, if for no other reason, a frank admission of the obvious fact that he knows less about a subject than the specialist who is teaching it is much more conducive to confidence than the assumption of knowledge he does not possess. In one particular, however, he may justly question the specialist on his own ground. As principal he must have a very definite idea why every subject is taught. Too often the specialist has never asked himself this vital question. He has studied his subject because he likes it. In it he finds the scholar's joy of achievement. Only too often he is teaching his subject rather than his boys and girls. Here should enter the principal as an enacting clause for that particular specialist.

This is often a difficult, sometimes an impossible, task. The unfortunate tendency of scholarship to view learning as an end in itself, — to forget the distinction between knowledge and wisdom, the tendency of teachers to live isolated lives, the cloistered vanities of intellectual Pharisaism, all

these make certain types of the "schoolmarm" — of both sexes — not infrequently a pretty difficult proposition. Happily, the proportion of such incrustated personifications of text-book learning are usually very small compared with the whole faculty. Sometimes one can be made an office assistant, sometimes a progressive school board or a pension fund comes to the rescue, sometimes such an infliction has to be endured as a limitation, like chronic appendicitis when the surgeons refuse to operate.

Who shall Pass? — An inevitable point of contact on this question of the purpose of the various subjects in the course will come in the grading of pupils. Professor George Drayton Strayer¹ of Columbia University has made a study of the markings given by various teachers in a subject and of those given by the same teacher at different times. He has shown that the standards of different teachers as well as those of the same teacher at different times are exceedingly variable. Who shall pass and who shall fail? What is to be the attitude of the administration on this question that is most vital to the pupils? What is the school to do with a condition that shows such an appalling percentage of failure as is evidenced by the New York Regents' examinations? The report for January and June, 1913, shows a failure of 28.8 per cent in all subjects. In all Latin subjects the failures were 34.4 per cent; in all mathematics, 32.9; in plane geometry, 40.2; in science, 34.6; in commercial subjects, 37.2. Yet the passing mark is only 60 per cent. Pupils are not permitted to take the examinations unless they have spent the specified time in class, and the majority of first-year subjects have been eliminated from the examinations. All of these considerations would tend to make the percentage of failure lower.

Limitation of the Teacher whose Chief Interest is in his Subject. — If these figures represent the high school failures throughout the country, it would seem that one of two things

¹ *Education*, December, 1913.

is true: either the tasks set for the pupils are badly adapted or the teaching is poor. The schools of New York State are, of course, compelled to follow the Regents' courses and take the Regents' examinations, but schools under a less rigorous régime should make it their business to see that their balance sheets do not show nearly 30 per cent failures. This is a plain duty of the administration, one that will not infrequently bring him into sharp and decisive controversy with teachers who are unduly strenuous in their devotion to their subjects. "I always discover in the first two weeks which of my pupils can do algebra," says one such teacher, "and then I teach them. Usually they are about 25 per cent of the class. I frankly tell the others that if they can't do the work, they must take the consequences." If every pupil is to be compelled to take algebra, a requirement that has little but tradition to support it, this teacher should be forced to change his practice or leave the profession. His case is in much greater need of discipline by the principal of the school than is that of a boy who frankly refuses to prepare his lessons, because the boy is injuring only himself, while the teacher, on his own confession, is injuring 75 per cent of the pupils assigned him.

The Purpose of Teaching a Given Subject should determine Content and Method.—In schools that have a fair degree of freedom as to the interpretation of any unit of the course there is an opportunity for the principal not only to see that pupils are not given work that is beyond the reach of the majority of the class, but also to see that the subjects really contribute something of value after they are learned. The following extracts from an editorial by M. V. O'Shea in the *School Review* for January, 1913, indicates the progress that is now well under way, but that has by no means reached its goal.

"It ought to hearten any teacher to note the changes which are taking place in our methods of teaching, particularly in the secondary school. The writer has been observing the new

order in a high school with which he is well acquainted. Five years ago German was taught to beginners in this school very largely from a grammatical textbook. After two years of instruction, the typical pupil could read a little classical German, but he could not read even this very readily or with genuine enjoyment. But to-day, in this same high school, pupils are at the outset introduced to spoken German, and they are required to speak it, to read it, and to write it almost from the beginning. They are now about as facile in the use of the language after six weeks of instruction as they formerly were after two years of grammatical drill.

“Five years ago the pupils in English classes memorized rhetorical rules, and read over examples in which they were embodied. Occasionally they would write a theme in the attempt to apply the rules which they had learned. To-day they are reading entire selections illustrating effective modes of expression, and they are writing a good deal with a view to expressing themselves on familiar subjects in a direct, clear, and pleasing manner. Five years ago algebra was taught as a purely formal, symbolical subject. But now there is considerable improvement, since pupils are constantly solving practical problems which have a more or less direct bearing upon everyday affairs, though we think still further improvement can be made in regard to this subject.

“We might go through with practically all of the subjects taught in this high school and show radical and encouraging reform in the way of employing vital and effective methods of teaching. The aim of making teaching *go to the mark*, in the sense that it will enable the pupil without waste of time or energy to get a subject as it will be of service in real life, is apparently coming to be accepted and generally practiced by teachers in the high school.”

An Illustration from History. — Perhaps no subject in the curriculum has been worse taught than history. The teacher has usually assigned so many pages of the textbook and been entirely satisfied when they have been parroted back to her. Professor John Dewey has shown the approach to this subject in a way that illustrates the duty of the ad-

ministration of a school to see that the subjects in the curriculum really function in the educational process. Says Professor Dewey:¹

“History is vital or dead to the child according as it is, or is not, presented from the sociological standpoint. When treated simply as a record of what has passed and gone, it must be mechanical, because the past, as the past, is remote. Simply as the past there is no motive for attending to it. The ethical value of history teaching will be measured by the extent to which past events are made the means of understanding the present, — affording insight into what makes up the structure and working of society to-day. Existing social structure is exceedingly complex. It is practically impossible for the child to attack it *en masse* and get any definite mental image of it. But type phases of historical development may be selected which will exhibit, as through a telescope, the essential constituents of the existing order.”

* * * * *

“One reason historical teaching is usually not more effective is that the student is set to acquire information in such a way that no epochs or factors stand out in his mind as typical; everything is reduced to the same dead level. The way to secure the necessary perspective is to treat the past as if it were a projected present with some of its elements enlarged.”

* * * * *

“History is equally available in teaching the *methods* of social progress. It is commonly stated that history must be studied from the standpoint of cause and effect. The truth of this statement depends upon its interpretation. Social life is so complex and the various parts of it are so organically related to one another and to the natural environment, that it is impossible to say that this or that thing is the cause of some other particular thing. But the study of history can reveal the main instruments in the discoveries, inventions, new modes of life, etc., which have initiated the great epochs of social advance; and it can present to the child types of the main lines of social progress, and can set before him what have

¹ *Moral Principals in Education*, Houghton Mifflin Co., p. 36 ff.

been the chief difficulties and obstructions in the way of progress. Once more this can be done only in so far as it is recognized that social forces in themselves are always the same, — that the same kind of influences were at work one hundred and one thousand years ago that are now working, — and that particular historical epochs afford illustration of the way in which the fundamental forces work.”

The Principal must visit Classes. — It follows, of course, that if the principal is to give the proper direction to the teaching in his school, he must visit classes. He must carry with him a vital philosophy of education, a keen sense of social values, a clear vision of his community and its needs, as well as a thorough understanding of the political, industrial, economic, and social forces that are shaping our civilization. He will not be able to evaluate the methods of his teachers unless he has this broader view of the place of the school in a democracy.

His discussion of the class work must be specific. He can point out to the younger members of his faculty many faults in technique that they will be only too glad to correct. He should be able to secure from all those not hopelessly prejudiced some response to his suggestion of the larger purpose of their various lines of instruction. He should make his ideals clear in his faculty meetings and follow them up with frequent visits and with many informal personal conferences. In the larger schools much of this detail work of supervision and conference will have to be done by the heads of departments. Inevitably, the time of the principal of one of our large city schools is largely taken up in meeting a great number of people — teachers, pupils, parents, and others — who, in certain relations with the school, ought to meet the official head himself. In such schools the leadership of the teaching force must be exercised to a great extent through the heads of departments. This will become much more efficient if the cabinet system is used, and policies are inaugurated which

represent the judgment of the cabinet rather than the *ipse dixit* of the principal.

The Teachers' Meeting. It should be Democratic.—The teachers' meeting, also, can be made a real force in the school. The cabinet is, or should be, a representative body. If the heads of departments really discuss matters with their teachers rather than lecture to them, they will bring to this cabinet meeting the composite judgment of their departments. The teachers' meeting, on the other hand, more nearly represents a truly democratic assembly. It may only too easily degenerate into a profitless debating society with a few loquacious performers in star rôles. To prevent this there should always be a very clear understanding when, and under what conditions, subjects are open to general discussion. Matters of routine detail can best be handled by mimeographed sheets of directions. These should be directions, not suggestions. Just what order of procedure is to be followed in reorganizing the school, for example, it is the province of the administration to determine, with whatever previous counsel it may seek. When the order is issued, it should be explained so clearly in a teachers' meeting that it cannot be misunderstood, the explanation should be clinched by the direction sheet, and then teachers should be held as rigorously to the letter of the order as would employees in any well-directed business.

But mere details should occupy relatively little of the time of the teachers' meetings. The principal who has a philosophy of education underlying his policies owes it to his faculty to make them understand his ideas. He will, therefore, very frequently discuss in some detail the educational questions involved in his program, and he will add a word of comment and interpretation to the incidents of the day's work whenever he can thereby make himself more clearly understood. But he will carefully avoid the appearance of continual lecturing, and he will endeavor to call out the best

in his faculty. A successful piece of work done in the school and explained in the teachers' meeting by the teacher responsible will often prove richer in suggestion than much of the principal's own comment. The public approbation accorded for good results is a powerful incentive to the faculty. A definite problem announced beforehand for consideration will often find ready solution from the discussion of those who see it from an angle other than that of the principal. A voluntary meeting occasionally where those teachers most interested contribute their ideas over a cup of tea will frequently reveal unsuspected strength and resourcefulness that are available for assistance to the administration. A committee report on an important problem will bring out valuable discussion and enlist greater interest in the general management of the school. It will also help teachers to see the many-sidedness of administrative problems. Too often the removal of a chronic difficulty looks to them so simple that they pass unfavorable judgments which would be withheld if they could come to see the whirlpool they would steer into in avoiding the rock they wish to shun. A reasonably variety in the program, opportunity for teachers to contribute, an evident purpose behind every meeting, live suggestions that can be applied directly in the class instruction, efficient interpretation of the activities, aims, and achievements of school will help to make the teachers' meeting one of the most vital elements in the progress of a school.

SCIENTIFIC MEASUREMENT ESSENTIAL. — One point of view of the utmost importance in all school management is just beginning to claim the attention of high school principals. For years we have gone on disputing about the value of various subjects in the curriculum, about fundamental theories of education, and about methods of organization, without studying how our results can be measured scientifically. Willy-nilly, we must compare the work of various teachers, we must report one for promotion and perhaps

another for dismissal. We must settle questions of curriculum and method because there is no one else to decide, and because we think that we are the ones best qualified to decide. For the most part we have done so in the past with comparatively little definite data. We have been obliged to support our conclusions with a few incidents that are more or less typical—or that we think are typical. We have measured our results with the yardstick of our desires or perhaps of our prejudices, and we have dogmatically announced our conclusion in universal affirmations. Fortunately the trail is now being blazed for a surer path.

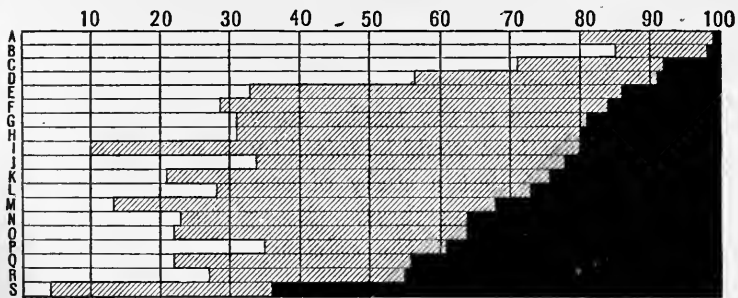

Graph showing an Uneven Department.— While the departments of education in our great universities are making elaborate studies, formulating various units of measurement, publishing the results of their experiments, and furnishing data that can be used as a basis for comparison, every high school principal who is not too heavily burdened can apply some part of the method of these investigations in his own school. If he will attempt to tabulate in graphic form some of the records of his own school, he will be amazed at the results. For example, the chart above shows the percentage of pupils passed by various teachers in the same department of one school.

Each line represents the work of one teacher in the depart-

ment. The blank portion shows the percentage of pupils passed without examination. The shaded portion shows the percentage examined and passed, and the black portion shows the percentage failed. It is evident that there is very great diversity of practice in this department. Some of this variability may be caused by excellent reasons. At least, however, it is subject to question why Teacher A should exempt 80 per cent of his pupils, while Teacher S exempts only 4 per cent of his. Possibly conditions for this particular term were unusual. Similar exhibits for several terms, however, in which each teacher handled a variety of the subjects of the department, would show conclusively whether or not Teacher S habitually marked forty-five times as severely as Teacher A. If he does, the chance of a pupil's passing this subject in this school would seem to depend largely on his good or ill fortune in the teacher to whom he is assigned. Many other questions would be raised by an efficient administrator who found that a study of one of his departments showed such results as these. One of the most evident questions would concern the efficiency of the department head.

Typical Statement of Pupil-hours per Teacher. — The fundamental question of the allotment of teachers to departments too often depends on the skill of the head of the department in presenting his claims to the principal or in some unfortunate cases to the superintendent or to members of the Board of Education. A very simple study of the pupil-hours per teacher will show at once where teachers are needed, or at least raise the question clearly what special consideration is to be given to the subjects that have to be handled in smaller groups, or to those which, like English, make unusual demands upon the teacher's time. A glance at the following statement of pupil-hours per subject in a certain school removes the question of the allotment of teachers from the realm of mere dispute:

SUBJECT	PUPIL-HOURS PER TEACHER
English	508
Latin	462
French	604
German	666
Science	691
History	681
Commerce	667
Mathematics	657
Domestic science and art	467

The method of a scientific statement of facts can be applied to school administration in an infinite variety of ways. A principal who has a grasp of the method can use it to the great advantage of his school in ascertaining where the school is efficient and where it is failing. He can also by this means present facts in such a way as to transfer many disputed questions from the realm of opinion to that of fact. He can effectually meet many criticisms that have their origin in insufficient data, snap judgments, or mere prejudice.

THE PRINCIPAL AND THE BOARD OF EDUCATION.

—The presentation of conclusions drawn from a study of conditions belongs to the principal. He is the expert, and so long as his conclusions are well-founded they should be accepted by the powers above him as the basis for the development of the school. The Board of Education that continually hampers its principal by meddling in affairs that belong to him, is one of the most discouraging hindrances to educational progress. Their proper relation to the executive head of a school or of a system should be similar to that of the board of directors of a corporation. Doctor Frederick W. Taylor, the father of scientific management in America, has defined the relations of such a board in a way that should be considered by any school board that thinks it should exercise the function of superintendent or principal. In a lecture before the Harvard School of Business Administration, Doctor Taylor said:

“The proper functions of the board of directors would be, for instance, to select, after having proper evidence presented to it, the broad and general type of management to be introduced in the establishment. . . . After having done this, and after having broadly stated the policy of the company, as to payment of wages and salaries, they should not mess into the detail of the personnel — by ordering the president to employ this man, or discharge that man, or promote another man. Nor should they vote a reduction of wages or an increase of wages contrary to the leadership of their president.

“Other functions of the board of directors should be, for example, dictating the broad policy to be followed in the sales department; namely, whether the sales are to be mainly conducted through agencies or traveling salesmen, and the extent and kind of advertising to be used. Again, however, the *details* of the executive work should be left under the direction of the president. The general financial policy of the company should also be one of the functions of the board of directors, as well as the broad lines along which progress is to be made. That is, the decision as to the type of new product to be manufactured and sold, and the volume of business which is to be prepared for.

“The president should lead his board of directors rather than be a tool to be guided by them in detail; and when it becomes impossible for the president to lead in the carrying out of the general policy of the board, another man should be selected for the head of the business who is in harmony with the board’s wishes and competent to lead them.

“The world’s experience in all directions has demonstrated the utter impracticability of doing successfully executive work under the management of a body of men either large or small. An executive committee of *one* is the best committee to have in charge of executive work. The president should be free to have as many advisers around him as he wants, and these men can be called an executive committee as well as by any other name; but their duties should be those of advisers. In all executive acts they should be under the orders of the president and they should not be allowed to control his acts by a majority vote. He should in principle occupy the same position as the President of the United States. He should be free,

practically, to select his own cabinet, and then should be in complete command of these men. The men under him should be free to advise him in the most emphatic manner, but the final decision in all matters should rest with him, and the board of directors should not entertain nor act upon appeals made to them from the cabinet officers beneath the president."¹

HOW THE DIRECTION OF OUR HIGH SCHOOLS CAN BE MADE MORE ATTRACTIVE TO FIRST-CLASS MEN.

— If our high schools are to be efficiently administered, the principalship must be made sufficiently attractive to command the services of first-class men. No longer can the public depend upon pure idealism as an incentive for young men to become teachers. School-mastering is no longer a ministerial profession. The allurements of business are unquestionably taking from the schools many of the most efficient men of experience as well as the vast majority of young men of superior education and administrative ability. A principal should have a good education, a strong moral sense, and enthusiasm for social service. He must also have first-rate executive ability. He must be able to meet people well, to judge human nature keenly, and to present his views clearly and convincingly. These are qualities that will command large returns and large freedom in the business world. Yet the public often demands such qualities at the price of a clerk or a bookkeeper. It often gets a man worth double the salary it pays and then requires him to do a large amount of clerical work that could be performed by a ten-dollar-a-week assistant. It very often expects him to do full service as a teacher, supervise the work of the rest of the faculty, and serve in a variety of public capacities classified under the omnibus title of "the Professor." In addition to this, many of the smaller towns subject him to carping criticism and interference that only too frequently either make him a petty

¹ Bulletin No. 5, *Academic and Industrial Efficiency*. Carnegie Foundation, 1910, p. 15.

schemer with his mind fixed on petty affairs or drive him in disgust from the profession.

In the cities there are many principals who are charged with the direction of from 1500 to 3000 pupils and the expenditure of from \$100,000 to \$300,000 annually. A difference in per-pupil cost of ten dollars a year would mean from \$10,000 to \$30,000 per year. Moreover, the difference in real efficiency between a principal who grasps the full significance of his task and one who sees it only in the light of academic tradition cannot be measured, because it enters into the very lives of the young people and through them into the communities they will help to form. Business would insist upon the best grade of ability in positions of similar importance, and it would make such a return in salary and in freedom to develop individual ideas that the best ability would be attracted to the positions. When the public exercises similar liberality it will be able to insist on a larger social return for its school budget.

THE CURRICULUM.—When the American high school first arose, and during what may well be termed the period of its struggle for existence, the need of higher education for any large percentage of our people was relatively slight. With an elementary school system of very meager proportions still in its infancy; with the principle of general taxation for education scarcely established; with little surplus national wealth; with few of the pressing problems of government, industry, and human relations, with which we of to-day are so familiar, not as yet markedly in evidence; and with but a small portion of our present organized knowledge as yet available for purposes of instruction, it can readily be understood that the high school of the earlier period was very limited in its scope, and was demanded by but a very small percentage of the people. Latin, Greek, and mathematics constituted the backbone and the bulk of all instruction; the course of study was the same for all; and the school was useful chiefly as a prepara-

tion for entering some one of the denominational colleges of the time.

The past fifty years, however, have witnessed very great and very significant changes in every feature of our national life, and the public secondary school has shared in these changes. Everywhere such schools have been adopted as a necessary part of a system of popular education, new classes of people have been attracted to them, and new subjects of instruction have been provided. The development of the secondary school since 1890, and particularly since 1900, has been marked. With the gradual evolution of the new conceptions as to the purpose and function of public education, there has been a gradually increasing demand that the secondary schools shall more thoroughly meet the needs of the new classes in the population which have turned to them for help and enlightenment. This has greatly changed the nature of high school work.

First to be introduced were history and English literature, and then the modern languages. In the seventies and eighties came the sciences, first in book form and shortly afterward as laboratory studies. Manual training and domestic arts came to be recognized as teaching subjects for special schools in the late eighties, and have since been incorporated as parts of regular high school instruction. Business training, at first introduced as a concession to public opinion and to meet the competition of the private "business colleges," has since been adopted as a useful addition, and, in the larger city high schools, is being transformed into good, strong, commercial or business courses. Still more recently agriculture has been admitted as a useful subject of instruction, and the development of the agricultural high school has been very rapid.

These many additions have affected the high school curriculum in two ways: (1) the old course has been expanded and crowded, resulting in the introduction both of elective

studies and elective courses; and (2) new types of high schools have arisen by the side of the old to minister to the new needs. These changes may be illustrated by a few typical examples of high school curricula, chosen from different types of American high schools, and by an enumeration of the different types of high schools which have been formed.

Types of High School Curricula.—I. A small New England high school, in which the one fixed, traditional course of study, almost entirely based on book work, has had to give way to changing demands and admit a few electives during the last two years. This type of school is still very common in conservative communities and among rural high schools.

First Year,	Third Year,
English Composition and Literature	English Literature
Ancient History	Modern English History
Latin	Latin (or German)
Algebra	Physics (or Bookkeeping and Business Arithmetic)
Second Year,	Fourth Year,
English Composition and Literature	English Literature
Medieval History	American History and Government
Latin	Latin (or German)
Geometry	Chemistry (or Typewriting and Shorthand)

II. A medium-sized city high school, located in the Mississippi Valley. Here, by combinations, five different courses of instruction have been arranged, supposedly to fit different types of individuals. Such combinations are quite common, though the tendency is to decrease the number of required subjects and to increase the number of electives in each. In the administration of the school this is usually done in individual cases, though not indicated in the paper courses of study.

I. ANCIENT CLASSICAL COURSE II. MODERN LANGUAGE COURSE III. HISTORY-ENGLISH COURSE

First Year,
Latin
Ancient History
English
Algebra

First Year,
German
Ancient History
English
Algebra

First Year,
Latin or German
Ancient History
English
Algebra

Second Year,
Latin
Greek
English
Geometry

Second Year,
German
Medieval History
English
Geometry

Second Year,
Latin or German
Medieval History
English
Geometry

Third Year,
Latin
Greek
English
Physics

Third Year,
French (or Spanish)
Modern History
English
Physics

Third Year,
Modern History
English
Physics
Drawing

Fourth Year,
Latin
Greek
English
(Elective)

Fourth Year,
French (or Spanish)
American History
and Government
English
(Elective)

Fourth Year,
American History
and Government
English
(Elective)

IV. SCIENTIFIC COURSE

First Year,
German
Botany
English
Algebra

Second Year,
German
Zoölogy
English
Geometry

V. BUSINESS COURSE

First Year,
(any other course)

Second Year,
(any other course)

IV. SCIENTIFIC COURSE (<i>Cont.</i>)	V. BUSINESS COURSE (<i>Cont.</i>)
Third Year, Physics Drawing Trigonometry (Elective)	Third Year, Spanish Business Arithmetic Bookkeeping Typewriting
Fourth Year, Chemistry Drawing American History and Govern- ment (Elective)	Fourth Year, Spanish Business Practice (Commercial Geography) (Commercial Law) (Shorthand)

III. A large city high school, located in the West, where fixed courses have been abandoned. The school offers a wide range of subjects, requires certain fixed units by groups, and makes up a different course of study for each high school pupil. The following studies are offered, the numbers in parenthesis following each indicating the number of years of each subject offered by the school.

GROUP I. — LANGUAGES

- Latin (4)
- Greek (3)
- German (4)
- French (2)
- Spanish (2)

GROUP II. — ENGLISH

- English Composition (2)
- English Literature (4)
- Hist. Eng. & Am. Lit. (1)

GROUP III. — HISTORY

- Ancient History (1)
- Medieval History (1)
- Modern English History (1)
- General World History (1)
- Am. Hist. & Govt. (1)

GROUP IV. — MATHEMATICS

- Algebra (1, 1½)
- Geometry (1, 1½)
- Trigonometry (½)
- Surveying (½)
- Business Arithmetic (½)

GROUP V. — SCIENCE

- Botany (1)
- Zoölogy (1)
- Biology (1)
- Physical Geography (1)
- Physics (1)
- Chemistry (1)
- Geology (½)
- Astronomy (½)

GROUP VI. — MISCELLANEOUS

- Music (2)
- Freehand Drawing (2)
- Vocal Expression (2)
- Physical Training (4)

GROUP VII. — VOCATIONAL	Household Management (1)
Mechanical and Geometrical	Bookkeeping (1)
Drawing (2)	Business Practice (1)
Manual Training (3)	Shorthand (1)
Domestic Science (2)	Typewriting (1)

Rules governing combinations and graduation :

(1) Students, to graduate, must complete 15 years' work, viz., four studies each year for three years, and three studies one year. (2) Students may, on permission, take as many as five studies or as few as three studies each half-year. (3) Students, to graduate, must have had two years' work in groups I and II, one year's work in each of the other groups, and four years' work in some one group. (4) Study cards must be made out each half-year, and must be approved by the principal and the parent.

The three types of high school courses given above illustrate the development which has taken place, and the tendency. Excepting agriculture, all new forms of instruction are represented in the one school. The advantages to the pupil are evident, while it is clear that such grouping of courses to meet individual needs as is provided for in the third type has advantages over that provided in the second type.

In some cities high school development has taken a different direction, and instead of expanding the high school to meet the many different needs, new types of high schools have been founded, and type or class high schools have resulted. There are to-day, in different places, the following different types of secondary schools.

(1) The so-called cultural or general high school; offering courses in the languages, literature, history, mathematics, and some science. This is distinctively a college preparatory high school. (2) The manual training high school; offering courses in science, mathematics, modern languages and history, English, and shopwork. This is preparatory for the engineering colleges, and work in shops and trades. It often includes the third type, for girls. (3) The household arts school. While usually included under the manual training school, a few such are being established separately. It offers

courses in English, history, the sciences, and subjects relating to household management, and is a technical school for women's work. (4) The commercial high school. This is an intensification of the commercial course, and offers good courses in modern languages, history, science, and office practice. It is preparatory for commercial pursuits on a larger scale than the old business course. (5) The agricultural high school. This offers courses in English, mathematics, sciences, some manual training and household science, and agricultural studies. It is preparatory for farm life, or for the colleges of agriculture.

It is desirable both that these different types of high schools should exist separately in some cases, and in many other cases should be combined in one. In their beginnings all new types of schools usually prosper better if provided for separately; but, after these new schools have established themselves and their work has been accepted as a good and legitimate educational effort, it is wise then to combine a number of such types in one school, and thus offer a larger range of choice to each high school pupil. The American high school, if it is to realize its highest educational purpose, should be preëminently a place for the testing of capacity, the development of tastes, and the opening up of vocational opportunities of many kinds. This involves intelligent oversight and direction on the part of teachers and principals, a rich and varied curriculum from which to select, and freedom from hard and fast prescriptions.

THE ELECTIVE SYSTEM OF SECONDARY SCHOOLS.

— In the course of its evolution, the high school has developed an extensive program of studies, — four or five foreign languages; English for every grade; mathematics for three or more years; two, three, or four sciences; history for two or more grades; and, in addition, manual and commercial subjects. These have contributed to the making of a program far too extensive to be within the reach of any one pupil. For a time, with the introduction of new subjects less and

less time was assigned to each, with the result that when the *Report of the Committee of Ten* was written, many large high schools were giving twelve and fourteen weeks' courses in science, short courses in history, and smatterings of three or more foreign tongues. The *Report of the Committee of Ten* greatly emphasized the desirability of an intensive treatment in the high school of relatively few subjects. The effect of this *Report* was only rarely the complete elimination of any subject from the high school, but generally resulted in a tendency to intensify and extend the treatment of each one. More than ever did it become necessary that the individual student should take but a part, and frequently a small part, of the entire range of subjects open to him. Another tendency contributing to the flexible course of study was the increasing range of capacity and interest found in the students of the high school. A variety of studies in science, drawing, commercial branches, and manual training were introduced to meet these demands. A third element in the development of the flexible course grew out of the conception in the *Report of the Committee of Ten* that it was of less importance what particular studies were pursued than what was the method employed in teaching them. From the standpoint of the majority of the Committee, each secondary school subject was assumed to have equal value with any other, if properly taught. It was, therefore, natural to assume, if a pupil manifested a strong aversion to Latin or mathematics, that some other equally well-taught subject could be substituted.

Not long after the appearance of the *Report*, students of education began actively to question certain fundamental assumptions implicit in it, and particularly the disciplinary conception advocated by the Committee. It was commonly asserted that Latin, better than any other subject, trained faculties of observation, verbal discrimination, powers of analytical thinking, etc. Equally, it was claimed that the study of mathematics strengthened reasoning powers and

greatly improved the capacity for systematic generalization. A series of critical articles, as well as certain investigations in psychological laboratories, tended during the last decade of the nineteenth century to unsettle existing preconceptions regarding mental discipline; in fact, there developed a tendency to assert that mental training should be a secondary consideration in the teaching of any subject, and that the subject itself should involve a content of knowledge or other power-producing material which should justify it, and that, in the course of its presentation, mental training would follow as an accompaniment.

Finally, in recent educational theory there has grown up an increased belief in the wisdom of adapting education to the individual. This represents a considerable departure from an older theory of education, that the individual should be fitted to a given field of subject matter. This change came about, partly, from the causes already presented. It was found that not only the interests, but the needs and capacities of secondary school pupils vary greatly. Furthermore, it was found that the important end of education was to prepare individuals for some field of activity wherein that which was learned in the high school would find application, either as culture or in vocational power.

The foregoing influences resulted in the development of the so-called elective system. It is true that, from its beginnings in the academy, the secondary school program had been somewhat elastic, but its elasticity had assumed the form of alternative courses, each course, however, representing a fixed and unvarying demand on the pupil. Naturally, alternative courses varied mainly in their demands for foreign language and for science; English and mathematics were usually prescribed subjects.

The elective system, however, carried the matter of alternative subjects to the point of allowing each pupil, within the limits of the range of subjects presented by the school

and the other inherent restrictions of program, substantially to make up his own course. From the standpoint of the school or the pupil, the important consideration was not always so much the subjects which could be taken as those which could be omitted. During the last years of the nineteenth century and the first decade of the twentieth, the literature of secondary education was filled with discussions of the elective system. It was felt by some that it represented a demoralizing tendency in that it weakened the educational conception of discipline through the more difficult subjects. Educational conservatives feared that it meant a persistent discounting of classics and mathematics. They apprehended a rapid development of the more vocational studies, and denied that the individual pupil had any capacity for self-direction in the choice of a program of studies. They asserted that, from the standpoint of the best development of the individual, it was highly important that certain fields of culture should be opened to him, even by compulsory methods. In only a few schools did the theory of free election of subjects make much progress. In these instances the graduation of the pupil was made to depend upon the accomplishment of a certain number of units of work, but without reference to any specific subjects. He might omit history or mathematics, no less than a foreign language or a branch of science. More commonly the system took the form of a certain number of prescribed studies, with a considerable range of alternatives or options from which the pupil could choose. In the case of some large high schools, for the requirement of specific subjects there was substituted the demand that, for graduation, a minimum number of units of accomplishment in foreign language, science, history, etc., should be presented, the pupil, however, retaining the privilege of electing among the various subjects in science or history as the case might be.

As a rule, few of the apprehended evils of the elective system have developed in practice. There has been an increased

tendency to induce the pupil to make his selections not only with the approval of some advisory teacher, but of parents as well. The limitations of the school curriculum, even in the larger schools, have acted as an important barrier to free election. Furthermore, the fact that a considerable number of students anticipate entering college, where the entrance requirements are more or less prescribed, has prevented anything like a free use of possible electives.

While the tendency is still to extend the possibilities of election of secondary school subjects, it is nevertheless true that important underlying problems must be solved before an adequate discussion of election is possible. There yet exists no satisfactory theory regarding educational values, especially of secondary school subjects. Quite universally, for example, algebra and geometry are prescribed for both boys and girls in secondary schools. Neither experience nor the tests of educational laboratories serve yet to demonstrate the superior value of these subjects. The same may be said to be true of the foreign languages so far as their training value is concerned. The science subjects have undergone steady modification in modern education, becoming more formal and rigid. There is yet no satisfactory evidence that, as now taught, these sciences contribute in an important way to either culture or practical capacity in greater degree than other possible subjects.

In prescribed programs it is the tendency to require subjects such as foreign language, mathematics, and science, which are most fully organized and which lend themselves most satisfactorily to traditional methods of pedagogic treatment. Until, however, there exists more satisfactory knowledge regarding educational values, it will be difficult to treat the subject of the elective system with anything like finality. It can be easily seen that the arguments for and against election hinge upon the theory of educational values and the capacity of a school to effect individual programs adapted

to the various pupils. If we believe that a limited number of well-organized secondary school subjects give either practical capacity, cultural insight, or mental training to be equaled in no other way, then it is a fair assumption that the school program should make these subjects prescriptive. There is little place for election, since the self-knowledge of the pupil and the experience of his parents are altogether insufficient to offset the results of the constructive effort which has gone to the making of the programs. If, on the other hand, we are inclined to believe that the educational values of certain subjects have been greatly exaggerated, and that what the pupil shall study is of less importance than his interest in the subject and the methods employed in teaching it, then it can easily be seen that satisfactory arguments can be made for allowing a part selection on the part of the pupil himself.

Other factors naturally enter into the discussion. Freedom of election means, naturally, that popular teachers will be sought and unpopular ones avoided, — a result which may tend to demoralize administration, and may or may not tend to promote more effective pedagogical methods on the part of the teachers themselves. It is believed that free election would tend to promote the study of practical subjects, at the expense of the more cultural, but again the relative educational values of the two types will be disputed. It is highly probable that a more extended analysis of the subject of election will have to wait a fuller and more scientific formulation of educational theory, as applied to secondary school studies.

There are many reasons for believing that the high school as at present organized contributes certain types of definite training more effectively than it develops culture and appreciation. On the other hand, the greatest deficiency of existing high school programs seems to be their incapacity to produce results of a persistent nature; for example, the study of a foreign language or of mathematics, even when well carried

on, fails largely in the face of later demands; the general goal aimed at is not realized. Distinctions will have to be made among various high school studies, with a view to determining the specific principles or purpose which each should serve in a program of fairly well-defined educational ends, and in adapting to each subject its own suitable method. This may be illustrated in the case of English. One object of the teaching of English in the high schools is undoubtedly efficiency of expression, both oral and written. Another object, however, and quite distinct from the above, is appreciation of good literature. It seems highly probable that these two ends will have to be attained by radically different methods. The same distinction will apply to certain of the sciences, when pursued from the standpoint of application in vocation on the one hand, or service in general culture on the other.

The general discussion of the elective system has probably greatly promoted interest in the problems of educational values. It brought subjects into competition, as it were, in a definite way. Until, however, more knowledge is available, many educators will assume that the choices made by the pupil, even when dictated by him and caprice, may, and, so far as he is concerned, will be no worse than the choice made by a more or less inflexible system which not only fails to take account of him as an individual, but which, to a large extent, has had its origin independently of the study of any group whatever of actual living individuals.

SIX-YEAR COURSE OF STUDY.— The fact that the American secondary school, unlike similar schools in Europe, takes the pupil at fourteen, or on the completion of an elementary course extending over eight years, is to a certain extent one of the effects of the historical development of American education. The common school or the elementary school was first established, and, in order to accomplish a full measure of general education, it involved eight or nine,

and sometimes ten grades, each a year in length. The typical American elementary school of to-day consists of eight grades, and carries the average pupil from the age of six to the age of fourteen. The first secondary schools — the Latin grammar school and then the academy — took on something of the character of European secondary schools, in that they maintained preparatory classes in which attention was early given to some secondary school studies. The public high school, however, was almost universally designed to succeed the elementary school course, and to build on it. As a consequence, admission to the high school everywhere requires the completion of an eight-year elementary course, and brings the pupil in at approximately fourteen or fifteen years of age.

This situation has obvious defects. It cannot be insisted, of course, that all American children, or even any considerable number of them, should complete the high school course of study. For those who do, however, the postponement of the beginning of foreign language study, as well as of algebra and geometry, works undoubted harm. For the boy who is to go through high school and into college, there can be little doubt but that the years between twelve and fourteen under the present system of schooling are largely wasted, at least, when viewed from the standpoint of the mastery of particular studies which should assist in the higher schools. The attention given to this subject in recent years has led to a fairly widespread demand for a six-year course of study in the high school, which should take pupils at approximately the age which is becoming customary in some European countries, and which especially should aid them to begin the study of foreign language at a time when the vocal and auditory organs are still plastic. The administrative difficulties have been so great, however, that only in rare instances has the experiment been made. The chief difficulty is found in the unwillingness of the American people to permit either a differentiation of

schools or a differentiation of classes of studies before the elementary school course has been completed. On the other hand, there is little tolerance for the prescription of foreign language study for all pupils in the upper grades of the elementary school. The result has been that, while a considerable literature has been produced bearing on the desirability of extending high school studies and high school methods downward, very little of a practical nature has been accomplished.

The problem is now being approached in some cities in a different way. It is recognized that the boys and girls from twelve to fourteen years of age possess certain distinctive characteristics and educational needs, which should separate them from the primary school which has preceded. In not a few cities it is now customary to group the upper grades in what are sometimes called intermediate schools, where favorable opportunities may be given for manual training, domestic science for girls, commercial studies, and, in a few instances, foreign languages. While few of these schools have reached the point of differentiating their courses, there can be no doubt that in a large number of instances they are ready to do so, if public opinion responds favorably. One of these schools in a Massachusetts city (Fitchburg) now receives pupils on the completion of the sixth grade, and admits them to any one of four courses. Certain studies, such as English, history, geography, and music are common for all, and are taken jointly in the classes. Certain other studies are alternative, and it is on the basis of these that the courses are distinguished. For example, boys who wish it may take two hours of manual training per day, and thereby become members of the industrial arts course; for them the arithmetic and drawing will also be somewhat specialized along the lines of the industrial arts. Another group of boys and girls, instead of manual arts, may take a foreign language, the beginnings of algebra, geometry, and English history. This is obviously a high school prepara-

tory course, and may legitimately be regarded as part of a six-year high school course, which it is hoped in time may become five years in length, thus admitting pupils to college one year earlier. A third course offers to girls two hours per day of household arts, the subject being treated very broadly, with related history and science. A fourth course, known as the commercial course, offers opportunities in typewriting, commercial arithmetic, the beginnings of bookkeeping, and a line of work wherein commercial geography and industrial history are combined.

It is not intended that any of the above courses shall be vocational, but that some of them shall draw from the world of vocational activities studies and problems that are significant and vital to the pupils concerned. Neither is it intended that any of the above courses shall be a blind alley, in the sense that it leads to no higher work. Nevertheless, it is obvious that a pupil from the industrial arts course who wishes to go through high school will have to take additional time in order to meet the language requirements.

The above represents a type of development in educational administration which will probably realize the purposes of the so-called six-year course of study, without involving premature differentiation of classes of pupils on the basis of their ability or economic state in life. It will afford an opportunity to make of foreign language study something more effective than is possible at the present time. It will promote departmental teaching, and the introduction of college-trained teachers in the higher grades.

TOPICS FOR FURTHER STUDY

1. How do principals and heads of departments spend their time? Classify under: (1) instructing classes, (2) visiting classes of other teachers, (3) assisting in the general administration of the school.

2. What is the relative efficiency of pupils from various grammar schools as measured by: (1) attendance, (2) remaining in school, (3) success in various subjects of instruction?

3. What is the relation of the size of classes to efficiency in instruction?
4. What is the earning power of graduates in relation to: (1) scholarship in various lines, (2) activity in student affairs?
5. Classify pupils' time allotment to the preparation of the various subjects of the curriculum.
6. Classify causes of leaving school. Compare studies of Ayers, Van Denburg, and Strayer and Thorndike.
7. What percentage of the total cost of the school is devoted to instruction in work that has once been pursued unsuccessfully?
8. Study failures and eliminations from school in relation to: (1) outside social activities, (2) misfits in course of study, (3) vocational ambitions, (4) financial pressure.
9. To what extent does the community life affect the high school in respect to: (1) courses offered, (2) the social life of the school, (3) preparation for higher education?
10. To what extent does the high school affect the life of the community?
11. What is the average percentage of absence and tardiness?
12. Classify causes of absence and tardiness.
13. How much does this absence cost in money?
14. How is the total time of the course in English divided between: (1) English literature, (2) oral composition, (3) written composition?
15. Experiment with 100 pupils taking foreign languages for a certain number of years and an approximately equal group taking no foreign language, but giving half as much time to English etymology and composition in addition to the regular English course. Test by written composition, spelling, and examinations in word derivation. Classify for comparison, sentence and paragraph structure, correctness in diction, ease and facility of expression.
16. What are pupils reading outside the work of the school?
17. What relation is there between pupils' outside reading and their success in various school subjects?
18. To what extent is there correlation between the departments as shown by questions like the following: To what extent are teachers in other departments teaching English? To what extent does drawing help in science, manual training, household arts? To what extent does history illustrate current problems?
19. What is the percentage of whole number entering who go to college? Percentage of graduates who go to college?
20. What is the relation of success in college to scholarship in high school? To participation in student activities?

21. How far is the outside reading of college students affected by the high school course in literature?

22. Classify college entrance examination questions in science and mathematics under, (1) questions having a practical application, (2) pure theory.

REFERENCES

- BROWN, J. F. *The American High School*. New York, 1909.
- BURSTALL, S. A. *English High Schools for Girls; their Aims, Organization, and Management*. New York, 1907.
- DAVENPORT, EUGENE. *Education for Efficiency*. Boston, 1910.
- DEWEY, JOHN. *Moral Principles in Education*. Boston, 1909. (Riverside Educational Monographs.)
- The School and Society*. Chicago, University of Chicago Press, 1900.
- GRAY, C. T. *Variations in the Grades of High School Pupils*. Baltimore, 1913. (Educational Psychology Monographs.)
- HOLLISTER, H. A. *High School Administration*. Boston, 1909.
- JOHNSTON, C. H., ed. *High School Education; Professional Treatment of the Administrative, Supervisory, and Specifically Pedagogical Functions of Secondary Education*. New York, 1912.
- MORRISON, H. C., et al. *Some Aspects of High-School Instruction and Administration*. (National Society for the Study of Education. 1914, Vol. 13, Pt. 1.)
- PERRY, C. A. *Wider Use of the School Plant*. New York Charities Publication Committee, 1910. (Russell Sage Foundation.)
- SACHS, JULIUS. *The American Secondary School and Some of its Problems*. New York, 1912. (Teachers' Professional Library.)
- STRAYER, G. D., and THORNDIKE, E. L. *Educational Administration; Quantitative Studies*. New York, 1913.
- VAN DENBURG, J. K. *Causes of the Elimination of Students in Public Secondary Schools of New York City*. Teachers College Publications, 1911.

Periodicals: —

- Academic and Industrial Efficiency. M. L. Cooke. Carnegie Foundation, *Bulletin No. 5*. 1909.
- Advisory Systems in High Schools. J. W. Raymer. *Educational Review*, 44: 466-491. December, 1912.
- Better Articulation of the Parts of the Public School System. F. F. Bunker. *Educational Review*, 47: 249-268. March, 1914.
- Committee on the Articulation of High School and College. *N. E. A. Proceedings and Addresses*. 1912, pp. 667-673.

- The Distribution of Pupils in the Public High Schools. A. J. Inglis. *Educational Review*, 46: 344-350. November, 1913.
- The Gap between the Elementary and the Secondary School. T. L. Wilson. *Educational Review*, 46: 295-299. October, 1913.
- Is Scientific Accuracy possible in the Measurement of the Efficiency of Instruction? G. D. Strayer. *Education*, 34: 249-258. December, 1913.
- Junior College; or Upward Extension of the High School. C. L. McLane, *School Review*, 21: 161-170. March, 1913.
- Making a High School Programme. M. W. Richardson. *School Review*, 17: 449-466. September, 1909.
- Measurement of Efficiency in Elementary and Secondary Schools. F. E. Spaulding. *Education*, 34: 225-248. December, 1913.
- Organization of a Large High School. J. A. Bole. *School Review*, 22: 1-11. January, 1914.
- Plan for the Reorganization of the American Public High School. Henry E. Brown. *School Review*, 22: 289-301. May, 1914.
- Progressive High School Reorganization. R. A. Mackie. *Education*, 33: 420-427. March, 1913.
- Reorganization of our School System. J. H. Francis. *N. E. A. Proceedings and Addresses*. 1912, pp. 368-376.
- Reorganization of Secondary Education in New Hampshire. H. A. Brown. *School Review*, 22: 145-156; 235-248. March, April, 1914.
- Reorganization of the Grades and the High School. E. V. Robinson. *School Review*, 20: 665-688. December, 1912.
- Six-year High School. George Wheeler. *School Review*, 22: 239-245. April, 1913.
- Studies in Secondary Education — Salaries and Teaching Conditions, *Educational Bi-Monthly*. February, 1914.
- A Study of Education in Vermont. Carnegie Foundation, *Bulletin No. 7*. 1914.
- Teaching High School Pupils how to Study. E. R. Breslich. *School Review*, 20: 505-515. October, 1912.
- The Worship of the Standard. W. H. Mearns. *N. E. A. Proceedings and Addresses*. 1912, pp. 193-200.
- Report of the Committee on School Inquiry*, Board of Estimate and Apportionment of New York City, Vol. 2, pp. 61-219. 1914.
- U. S. Bureau of Education. Economy of Time in Education; Report of the Committee of the National Council of Education. *Bulletin No. 38*, 1913.

CHAPTER VI

THE PRIVATE SECONDARY SCHOOL

CHARACTERISTICS OF PRIVATE SCHOOLS. — A working definition of the term "private school" would be generally given and generally accepted in some such form as this: That while public schools are supported and controlled by the state government, private schools are self-supported and free of government control. As a corollary they are not open to all comers, but tend to be schools attended by a group or class. More is made of questions of personality and of special aim.

The self-support characteristic of private schools may take either one of two forms. A private school may be a commercial venture supported by direct payments to the manager or "owner," or it may be supported by subscription or endowment, so that the element of profit is more or less eliminated. The first form has comprehended, perhaps, the larger part of the private school group. Its characteristics are of course well known, and the sentiment of Socrates against it generally prevails. Commercial processes introduce self-advertising, often cunningly concealed but often very blatant; commercial attitudes of bargain and dicker encourage mutual hostilities and the taking of advantages on both sides. These things are unwholesome between teacher and taught. Moreover, commercial patronage is hardly the attitude for a true seeker of instruction. Yet these dangers are in practice not so great as they seem. In the first place, there are saving and antiseptic influences in the occupation itself which meet and repel these infections. Just as, in the modern world, the

publication of books and newspapers, or the production of art and music, is left solely to the support and judgment of the market, so churches, museums, schools, theaters may and do appeal to direct patronage without ruinous results. And there are also many counteracting advantages in this form of organization. Private-venture schools are always very close to the true demand of the public; what people want, they know. They tend, moreover, to collect about interesting and effective personalities. Private schools get more than their share of good as well as of bad teachers. The relation between teacher and taught, being a matter of free choice, and not controlled by a system of appointment, tends to be personal and endearing. Probably the most permanent service of private schools, since they are thus flexible, lies in their utility as experimental schools. Their experiences serve as models or warnings to the community. Among what may be called the "marginal activities" of the school organization, private effort will always play a valued part; for no step to advance in education has ever been taken without the leadership of private schools. They are not the home of lost causes and impossible loyalties; they work in advance of the main body.

But though at present all lists of private schools are dominated by this type, yet the endowed schools seem to be increasing and are perhaps destined to play a leading rôle among private schools in the future. They are more permanent than private-venture schools, they have longer and riper tradition, they have generally more capital and resources, and they harmonize with the modern tendencies to combination and to large enterprises. The endowed private school may be a stately institution, indistinguishable in structure and character from a large public school. It may have a long-descended pedigree; it may represent a religious tradition, or a much-loved social tradition; it may have an honorable history of educational attainment. It is by its per-

manence emancipated from dangerous commercial traits, while on the other hand it is free to follow, without confusion or control, its special task or special aim. Like a voluntary, religious organization, such schools "enjoy the immense advantages of freedom of association, of personal initiative, of individual growth." They are important beyond their number.

VALUE OF PRIVATE SCHOOLS. — Self-support, personal freedom and personal care, flexibility of organization, and prompt adjustments being the virtues of the private school, it will soon appear that the private school counts much more in some parts of the educational field than in others. It is not too much to say that in all elementary education, in comparison with the public school, the argument for the private school amounts to very little, and the tendency of modern educational evolution is all against it. In the *Report* of the United States Commissioner of Education for 1910 it is stated 93 per cent of all children attending school in the United States are attending elementary schools and that 92.6 per cent of them are in public schools. The same observation might be made of Germany or France. To find any considerable amount of private elementary work one must look to the more or less tolerated religious schools. But even in countries where this kind of school exists as a significant part of the public system of elementary education, it is more and more coming under government control. This is the only important type of private elementary school. Other motives for private elementary work produce little result.

PRIVATE SECONDARY SCHOOLS. — A brief survey of the field of education will show that secondary education is the special home of the private school. Among private schools originated every form of what is now known as high-school work in America. A large fraction of it is still done by them, probably from a fifth to a quarter. Nearly the whole of secondary education in England up to 1902 was of

the private-school type. Even in Germany and France, the secondary schools, though under strict government control, are class schools, receiving fees, and belonging to the *bourgeoisie* in type.

In Denmark and Norway, in Sweden and Finland, the private schools are of special importance and influence, more particularly as regards secondary education. In all these countries the state leaving examination which is passed at or about the age of eighteen is the only portal to the university. Candidates are prepared for it either (1) in state schools, in municipal schools, and in recognized private schools, or (2) in schools which have not gained or perhaps have not sought recognition, in private courses, and by private tuition. In the latter cases they are called privatists, and are subjected to a somewhat severer test.

These two leaving examinations are the medium by which the recognition of private schools is effected. If, in buildings and equipment, in curriculum, efficiency of staff, and salaries, a school reach a satisfactory standard, it is allowed to hold the leaving examination within its walls, just like a state school; and its masters, in the presence and under the guidance of a government-appointed censor from outside, conduct the *viva voce* part of the examination (a specially interesting and important feature in all these countries), whereas privatists have their examinations both written and oral conducted by an examination board who are strangers to the candidates. Such private recognized schools are regarded as helping to make up the national provision of secondary education; their statistics are found alongside those of the state schools; masters or mistresses from the one kind of school easily pass into service of the other — from the private school to the public or (less frequently) from the public to the private, — and not unfrequently a teacher may be found engaged in both kinds of schools at the same time. Teachers from a public school are as often as not found acting as government

censors at the examinations in a private school; and just as often teachers in a private school act as government censors at a public school. Thus the two kinds of school are perpetually acting and reacting on one another, to the good of both; each tends to impart to the other its characteristic virtues and excellences; and the two, by varying methods, work harmoniously and effectively towards the same goal — are indeed, so far as it is desirable, welded into one.

Even if in time more of our American work goes to the public high schools, still there are some legitimate demands for variety in secondary school life which various forms of private school must always be called upon to satisfy. Some things the public high schools would not do, if they could, or could not, if they would. Some of these demands will necessarily create private schools. And at any rate, looking at the matter from another angle, as long as there are private schools, for any reason, the larger part, the stronger part, and the best part of them will be secondary schools.

Vocational Schools. — The needs of the adolescent are various to infinity. The possibilities of secondary work are therefore legion. They may be roughly classed as vital, *i.e.* concerned with the development of personality, or vocational, *i.e.* concerned with the conservation of that personality to its life work. Of these, to the children, the most conscious, the most imperative, the most educating are the vocational preoccupations. But these have been, however, for several generations in our public schools strangely misunderstood, misappreciated, and neglected. Children have been obliged to seek their vocational training in America out of school. The effect is naturally the well-known early departure of American children from schools of the state. Only 5 per cent of the school population is reported to the Commissioner in 1909-1910, as attending public high schools.

Now private vocational schools not so reported have made up for a large amount of this neglected work. For example,

the "business colleges" and schools have accomplished much good vocational work. Generally they have been private ventures, originating spontaneously out of the pressing need. Most of these are still of this sort. But there are beginning to be private endowed schools which promise still more in the future. And the college and university courses of this sort must soon be reckoned with. Other occupations are represented in the community by private schools. The schools of music and other arts, whose names fill up the educational directories of our cities, are mainly such. They originate in the demands of the locality and are private ventures, though there are some with private endowments, and some are affiliated with colleges and schools with endowments not under government control. They are exceedingly numerous and well attended. Handicrafts are taught in this way in an increasing number of schools, *e.g.* schools of telegraphy, dressmaking, cooking, pharmacy, and schools with a more comprehensive sweep like "mothercraft" and "philanthropy." There are advanced schools, under private management, but growing in publicity. We find the vocational trade schools and manual training schools of a general type, originating in private endowment and charging fees, but of great public power and value. We find great schools connected with special industries. We find trade schools connected with churches. The whole field of secondary training is filled with vocational private schools, setting an example to the public schools, nowadays gravitating themselves toward the public school system, but to be reckoned distinctly as part of the creditable result of the American individuality in education which would be seriously missed, if lost in the future, and which is embodied in private schools.

Among the vocational occupations of secondary schools is preparation of candidates for entrance not directly into the markets of life but into higher institutions of learning. In this class one might reckon candidates for government service

and other occupations protected by examination or certification. No public school system can cover this ground completely. Army, navy, civil service, professional and technical schools, scientific work, have so many varying needs as to create a large body to give private preparation. Special dexterities imply special schooling. Hence the need here of private schools.

Preparatory Schools. — A most significant group of schools in America, called “preparatory schools,” or “fitting schools,” has originated in the need of previous preparation for the college and universities, until recently themselves private schools. These schools have many special intellectual and social ideals; but this work, though actually, for historical reasons, rather specially linguistic and theoretical, has been accepted as representing several essential requirements for secondary culture. They have thus enjoyed a great prestige; and have been used to determine the course of public as well as private secondary education. They have been discussed and standardized by committees and other bodies appointed for this purpose, and doubtless exercise a great and wholesome influence over American education.

The participation of the public high schools developed in the last fifty years in the work of the preparatory or fitting schools of America has been of great service to education in the standardization of college requirements, and in the move for uniformity as against the somewhat capricious and confused diversity of different college demands. Private and public schools have worked side by side, and the massive power of the public school has made itself felt. In the immediate future public schools may be even more useful in a similar way; speaking in the name of the general public, they can assure the colleges and universities, as private schools cannot, that they may now safely admit to their work, without too much distinction among subjects prepared in school, any person of suitable intellectual stature and competency.

But great as are the hopes for the public school, nevertheless, as far as special preparation demanded by higher institutions is concerned, this will probably in the end remain a factor most stimulating chiefly to the creation of appropriate private schools, as it is now a leading interest among them.

Another form of usefulness of the preparatory schools has been collateral among the groups of secondary schools in general. Not only is their work in their own task a significant part of the sum total of secondary education; but they have also influenced the theory and practice of all other secondary schools about them. This influence counts among the services of private schools to the country. Even where the public high schools have outdone their models, the private schools have after all many times set the fashion.

Military Schools. — Another special form of training deserves mention by itself, among the activities of private schools. In Europe the educational effects of universal military service have often been favorably commented upon. Even where, however, this service is universal and compulsory, there are special schools for vocational training of officers. In England, with certain brilliant exceptions, this work is left to volunteer effort. In America we have always had West Point and Annapolis, our only special schools to look up to for models and leadership. But, with some exceptions in the matter of drill and organization, the private schools in this country have taken over this matter entirely. The military schools of this country are private schools. Like all private schools they vary in efficiency; but the best of them show the great effects of a vocational ideal of a high code pursued with devotion. It is maintained in a recent article that the military situation in the United States is distinctly benefited by these military schools. Whether this belief be justified or not, the effects of their training on the schools and pupils are justly valued. The only criticism offered against them has been their tendency, owing to the

superior efficiency of their moral training, to collect difficult cases in them, a criticism which has been made also of boarding schools, small colleges, and all private schools.

Denominational Schools. — The forms of private school hitherto considered contemplate school chiefly as preparation for life. This ideal, however, does not contain the whole case. There must be motives for the creation of schools in which vocational preparation plays a less prominent part. School years are branches of the Tree of Life not less than of the Tree of Knowledge, and in their ethical and spiritual experiences must be reflected ideals of great influence and worth. There is, for example, the religious life, very hard to provide for in governmental schools. Governments can in modern times recognize no religious body above another; the religious experience must be left to church and home. Here is a most powerful and apparently most permanent argument for the creation of private schools. All religious bodies feel this impulse. Of the private high schools dealt with in the *Report* of the Commissioners of Education, two thirds are conducted by religious bodies. A large part of the colleges and universities in the United States are either under direct control of some religious body or in close affiliation with it. The Catholic Education Association, for example, has on its roll 67 colleges, 16 seminaries, 980 schools. The Protestant denominations are not backward. There are even schools intended not merely to be non-sectarian, but carefully to diminish religion as life experience. All this is necessarily private school work. Modern government schools must apparently be secular.

SOCIAL SELECTION. — But there are other life experiences than religion which governmental schools cannot formally recognize except as incidents and by-products of their history. Among them are the experiences, the ideals, the habits, associated with family life and the life of social groups. On the basis of social selection there are reared the most

famous and perhaps the best of the private schools. The great English schools represent a social class. There are such schools, though closely under government supervision, in France and Germany, representing social distinction as well as religion. In America, while we recognize that our ideals, our ethics, even our manners and customs, must in the main be such as to fit us to belong to the great public family of which we are all proud, yet even here there are family groups of a more private character, which seek for separateness and distinction, especially in education. How valuable such things may be is a matter of some dispute. The doctrinaire democrat is apt to denounce such ambitions; the parent face to face with the problem of his son's life is perhaps apt to overvalue exactly such distinctions as are cherished in private schools in some quarters.

The discreet American need not take sides. He will remember the federal constitution and the country's motto. At any rate, in the ebbing tide of family life, especially in the great cities, artificial family experiences seem now called for in school life; in many situations public schools may and do efficiently perform this function, yet there are situations, unsolvable by schools open to all comers, which must be met by schools of private effort. Many schools, even in America, must exist which intend no more and profess nothing else than social and domestic privacy. These schools are not necessarily objectionable or of no service to the state. "We begin," says Burke, "our public affections in our families." We certainly may begin them in such a private and secluded school, which is after all full of corporate spirit. There is no evidence that the academies of the eighteenth century or the boarding schools or private day schools of our own time have not produced their share of public servants.

The scouting parties and forlorn hopes in the warfare of the Liberation of Humanity belong to private schools. It should be remembered that there is an ambiguity in the phrase

“public service”; it connotes both what is done for the public and what is done by it. The main question about any educational institution therefore is not, who pays for it, but what it is worth to the common good. “Modern states,” says the Commissioner, “shall certainly see to it that any citizen of any age who seeks instruction in any subject shall find instruction provided for him, not necessarily at the public expense, but made actually available for him by ways that are in his reach.” In aiding citizens to forms of education not yet or not at all within reach of the public school, the private school has its permanent meaning.

TOPICS FOR FURTHER STUDY

1. How did private schools originate in Continental Europe? How in England? How in America?
2. What justification of private schools is given by educational theorists, beginning with Quintilian?
3. To what extent were the academies, especially those of the first half of the nineteenth century, private schools?
4. Was there greater justification or need of private schools in the United States in the last half of the nineteenth century than there is in the twentieth?
5. What influence has the private school exerted on the development of the curriculum? Of method?
6. What value does the private school have for the pupil?
7. What value does it have for society?
8. What are the chief defects or difficulties in the work of the private school?
9. Is there greater need for private secondary schools than for private elementary schools?
10. Is the government justified in demanding the right of inspection of private schools?
11. Is the government ever to be justified in demanding the suppression of private schools as a type?
12. Would the standardization of private schools on the same basis as that of public schools be an advantage?
13. Is there a greater justification for private schools in countries like Germany and France than there is in the United States? In England than in the United States?

REFERENCES

- BROWN, E. E. *The Making of our Middle Schools*. (Historical.) New York, 1903.
- BURSTALL, S. A. *Education of Girls in America*, Chap. III. New York, 1894.
English High School for Girls. New York, 1907.
Impressions of American Education, Chap. II. New York, 1909.
- CHANCELLOR, W. E. *Our Schools*, Chap. X. Boston, 1904.
- JACKSON, G. L. History of Secondary Curriculum since the Renaissance, in Johnson's *High School Education*, Chap. III. Applicable to private school curricula. (Historical.) New York, 1912.
Journal of Education, May, 1893. The number of private schools was estimated at from 10,000 to 20,000.
- LOOS, J. *Enzyklopädisches Handbuch der Erziehungskunde*, s.v. *Privatschulen*. Also *Landerziehungsheime*.
- LYTTLETON, REV. HON. CANON. *How State Organizations will affect the Interest of existing Public and Private Schools*. Paper at Conference of the Teachers' Guild, Oxford, 1893.
- NORWOOD, C., and HOPE, A. H. *Higher Education of Boys in England*. (English Public Schools.) London, 1909.
- PHELPS, W. L. *Teaching in School and College*, pp. 41-50, on Private School Teaching and Scholarship. New York, 1912.
Report of Commissioner of Education for 1911, Vol. II, Chap. XXXI. Public and Private High Schools; also each annual *Report*.
Report of the Royal Commission on Secondary Education, Vol. VII, p. 455. London, 1895.
- SACHS, J. *The American Secondary School*, Part II. New York, 1912.
- SCOTT, R. P., and others. *What is Secondary Education?* Chap. XIX. London, 1899.
The Private Schoolmaster. A monthly published in London.
- THORNTON, J. S. Education in Northern Europe; The State and the Private School. *Educational Times*, Vol. LVIII, pp. 482-483.
Facts and Opinions from Public Men on Private Schools, 1893-1894. A paper compiled for the Private Schools Association.
Public Schools and Private in the North of Europe. English Special Reports, Vol. XVII, 1907.
- TWING, C. F. *History of Higher Education in America*. New York, 1906.
- U. S. Bureau of Education. Public and Private High Schools. *Bulletin No. 22*, 1912. Washington.

- WATSON, FOSTER. *English Grammar Schools to 1660*, p. 156 sqq.
Cambridge, 1908.
- Beginnings of the Teaching of Modern Subjects in England*. London,
1909.
- Unlicensed Nonconformist Schoolmasters, 1662 onwards. *Gentle-
man's Magazine*, September, 1902.

CHAPTER VII

PSYCHOLOGY AND HYGIENE OF ADOLESCENCE

PHYSIOLOGICAL SIGNIFICANCE OF THE ADOLESCENT PERIOD. — The period of secondary education coincides very closely with the first half of that term of years between the ages 12 to 14 and maturity, which is known as the period of adolescence (Latin, *adolescere*, to grow up). The initial stage of adolescence, the period of puberty (Latin, *puber*, *pubes*, grown up), is that stage of physical development at which an individual first becomes capable of begetting or bearing children, and this maturing of sex functions affords the essential and salient cue for the interpretation, not only of the physical but also of the mental and moral development of the entire adolescent period. Adolescence is, then, to be regarded as a period of marked and significant developmental growth — a growth both of body and of mind.

Biologically, then, the individual becomes, during the period from puberty to maturity, capable of undertaking his part in the perpetuation of the race. So rapid and so far-reaching are the alterations effected in bodily structure and in mental traits that they may be fitly compared with those still more rapid and significant developmental phenomena observable during gestation and early infancy, so that it may be said, as Rousseau has phrased it, that “We are born twice, once to exist and again to live; once as to species and again with regard to sex.”¹ And it follows that it is quite impossible to understand the high school pupil or to elaborate any interpretative theory of adolescence save by reference to this fundamental underlying fact that adolescence is the period of life when sex functions mature.

¹ *Emile*, Book IV.

The onset of puberty varies in time. Chronologically, it is customary to assign the appearance of puberty to the twelfth or thirteenth year in girls and to the fourteenth year in boys. However, every extended investigation that has been conducted has shown that these are but average figures. Thus, some boys are pubescent as early as the tenth year, others not until as late as the eighteenth year (Table 1).¹ Analogous figures for the first time of the first appearance of puberty in girls (Table 2)² reveal much the same range of variability.

TABLE 1

VARIATION IN PUBESCENCE OF 4800 BOYS IN A NEW YORK HIGH SCHOOL (CRAMPTON)

MEDIAN AGE (APPROX.)	IMMATURE OR PREPUBESCENT	MATURING OR PUBESCENT	MATURE OR POSTPUBESCENT
12.75	69%	25%	6%
13.25	55	26	18
13.75	41	28	31
14.25	26	28	46
14.75	16	24	60
15.25	9	20	70
15.75	5	10	85
16.25	2	4	93
16.75	1	4	95
17.25	0	2	98
17.75	0	0	100

¹ See particularly the results published by C. W. Crampton, M.D. The Influence of Physiological Age on Scholarship, *Psych. Clinic*, 1: 1907, 115-120; also Anatomical or Physiological Age versus Chronological Age, *Ped. Sem.*, 15: 1908, 230-237, and Physiological Age — A Fundamental Principle, *Amer. Phys. Educ. Rev.*, 13: 1908, 141-154, 214-227, 268-283, 345-358.

² A. Marro, *La Puberté chez l'Homme et chez la Femme*. (Translated from the 2d Italian edition), Paris, 1902. See especially p. 22.

TABLE 2

DATE OF ONSET OF PUBERTY IN 261 GIRLS, OBSERVED BY
MARRO

Year . . .	10	11	12	13	14	15	16	17	18	19	20	21
Number	1	6	16	34	61	54	40	29	12	4	2	2

Variability is itself Characteristic of the Period. — The individual variability here revealed in the date of entrance into the adolescent period is a phenomenon that is equally evident in the other physical and mental changes of the period. That is to say, the range of differences between individuals with respect to any trait is much greater during adolescence than during childhood. Indeed, so variable are many of the signs of adolescence as to render generalization about them either difficult or at least perplexing, when the individual pupil is under consideration. This accentuation of individual differences during the high school period has led to the conviction that the educational machinery of the secondary school should possess a reasonable amount of flexibility, that more heed must be given than in the elementary school to the needs of the individual pupil in curriculum, method, pace of work, and in similar matters.

Physiological Age. — The variability just cited in the date of onset of puberty affords us the concept of “physiological age.” A pupil’s physiological age is determined by the stage of physiological development he has attained. We have already seen that his physiological age may or may not correspond with his chronological age. In a similar manner, a pupil’s psychological age corresponds to the stage of mental development he has attained. Finally, his “pedagogical age” is given by his status or grade in the school system.

The Concept of Retardation and Acceleration. — One of the most interesting problems raised by recent investigation relates to the correspondence or correlation between these

several "ages." A pupil may, for example, exhibit either "retardation" or "acceleration" in any one of these ages when it is related to any other one of them. It has been common to speak of retardation when pedagogical age is behind chronological age, but we may also find other forms of retardation — physiological, for instance, in the case of pupils who enter puberty after 15.

Relation of Physiological Age to Success in High School.

— The relation of physiological age to success or failure in high school work has been investigated of late, though with somewhat conflicting results. Crampton¹ asserts that in the high school the immature (prepubescent) boys at all ages exhibit many more instances of failure in school work than do the mature boys.² The more recent work of Dr. W. L. Foster³ shows that one third of the boys entering New York high schools are discharged during the first term, but that these discharges are reduced by from 7 to 11 per cent when entering pupils are placed in sections or groups of like physiological age, based on degree of pubescence. The explanation offered by Foster is that the boys then find their school associations "pleasanter" and tend to stay in school for a longer time.

Inspection of Foster's tables shows that, in a class of 295 pupils sorted into eight groups by physiological age,⁴ of 58

¹ *Ped. Sem.*, 15: 1908, 230-237.

² On the contrary, in the elementary grades in New York City, there are, according to the same investigator, in grades 5c to 7a, thousands of pupils who are physiologically mature, but who are deficient in scholarship. These boys are naturally poor scholars, who are kept in schools by the compulsory education laws and who find the school work particularly trying and irksome.

³ *Physiological Age as a Basis for the Classification of Pupils entering the High School*, *Psych. Clinic*, 4: 1910, 83-88.

⁴ The sorting was accomplished by making a direct examination of the degree of pubescence, but the author believes that the relation of pubescence and height is so close that a practical grouping could be made on the basis of height alone. However, the natural range of variation in height is so great and the amount of overlapping of heights in Foster's own groups was so great as to cast doubts upon the feasibility of so simple a procedure.

discharges, 33 were in the four most mature groups; of 58 failures, 40 were in the four most mature groups; while of 179 promotions, 100 were in the four least mature groups. These results flatly contradict Crampton's generalization. All in all, more investigation is needed of the interrelationships of the several "ages," with special reference to the pupils entering the secondary school.

Foster says distinctly: "It is quite certain that the boy of Class I (the most mature group) will never be first in scholarship." And for this he offers at least a partial explanation: "Many of them were delayed in their progress at school or by circumstances at home. Going to work is usually out of the question for a small boy, and in social affairs and in athletics he is not at all successful. The influences that tempt the big fellow to neglect school duties do not have the same force against the smaller boy." Again, some of the big boys enter the high school a year or more after graduation from the elementary school; others of them are undoubtedly innately dull — a statement that raises the query whether the apparent good that resulted from the segregation may not have been due to a grouping of psychological age after all.

Aside from these bodily changes directly connected with the maturing of sex, the most marked physical sign of early adolescence is the augmented rate of bodily growth.

Growth in Height and Weight. — Measurements of the height of some 88,000 American school children and of the weight of nearly the same number have afforded the valuable statistics of growth reproduced in Tables 3 and 4.¹

¹These norms of stature have been calculated by Boas (*Report Commissioner of Educ.*, 1896-7, ii, 1541-1599) from studies by various investigators of school children in Boston, St. Louis, Milwaukee, Toronto, and Oakland, Cal. The same averages converted into inches are published by F. Burk (*Amer. Jour. of Psych.*, 9: 1897-8, 253), from whose article the norms of weight calculated for Boston, St. Louis, and Milwaukee children have been taken. Curves showing the distribution by percentiles of the height and weight of children of both sexes for the ages 4 to 18 have been issued by F. W. Smedley (*Rept. Dept. Child Study, Chicago*, No. 3), and are reproduced in part by Whipple (*Manual of Mental Tests*, 2d. ed.).

TABLE 3

AVERAGE STATURE OF AMERICAN CHILDREN, IN CENTIMETERS

Age . . .	5.5	6.5	7.5	8.5	9.5	10.5	11.5
Boys . . .	105.90	111.58	116.83	122.04	126.91	131.78	136.20
Girls . . .	104.88	110.08	116.08	121.21	126.14	131.27	136.62
Age . . .	12.5	13.5	14.5	15.5	16.5	17.5	18.5
Boys . . .	140.74	146.00	152.39	159.72	164.90	168.91	171.07
Girls . . .	142.52	148.69	153.50	156.50	158.03	159.14	—

TABLE 4

AVERAGE WEIGHT OF AMERICAN CHILDREN, IN KILOGRAMS

Age . . .	6.5	7.5	8.5	9.5	10.5	11.5	12.5	13.5	14.5
Boys . . .	20.50	22.45	24.72	27.03	29.66	32.07	34.88	38.46	43.18
Girls . . .	19.69	21.64	23.81	26.03	28.53	31.52	35.70	40.23	44.59
Age . . .	15.5	16.5	17.5						
Boys . . .	48.72	54.88	—						
Girls . . .	48.40	50.94	52.34						

It will be seen that boys are slightly taller and heavier than girls of the same age during childhood and up to just before the onset of puberty, whereas girls are taller than boys between the ages 11.5 and 14.5 and heavier than boys between the ages 12.5 and 14.5. This crossing of the curves of growth of the two sexes is due to the fact that the acceleration of growth which ushers in adolescence comes earlier in girls than in boys. Boys, however, overtake girls, once they reach their own period of acceleration, and, since they continue to grow at an accelerated rate for a longer period, come ultimately to exceed girls by a greater amount than in childhood. A similar phenomenon appears in other anthropometric measurements, *e.g.* that of vital capacity, and of strength of

grip, though in these other cases the accelerated growth in girls does not happen to be sufficient to bring about an actual crossing of the curves of the two sexes.

The period of most rapid growth does not, as has sometimes been said, take place just before puberty, for when pupils are divided into groups according to degree of physiological maturity, it is found that prepubescents grow slowly in height, weight, and strength. On the contrary, the year of accelerated growth in all these respects is the first year of postpubescence, regardless of its chronological relations.¹

Growth and Health. — While it is true that for some individuals, more especially for some girls, the pubertal period is attended with ill health and fragile physique, the evidence of vital statistics shows clearly that these cases are exceptions to the rule. Hartwell's study of the death rate for the city of Boston showed that the period of pubertal change is the period of lowest death rate, while the commission headed by Axel Key,² that examined 15,000 boys and 3000 girls in Swedish schools, found that capacity to resist chronic diseases was highest when growth was most rapid, and that the seventeenth year was the most healthy, the thirteenth and eighteenth relatively sickly. The indications are, therefore, that early adolescence is a period of strong vitality.

Growth by Parts. — When we examine the growth of the different organs and structures of the body, we find that they participate to a very unequal extent in the rapid growth of adolescence. Moreover, the periods of most rapid growth, the nascent periods, of different organs do not coincide. And finally, organs differ in the duration of their periods of growth. Instances of these principles are given below, and many more might be adduced to show that growth is "by parts," not

¹ See Crampton, *Psych. Clinic*, 1: 1907, 115-120.

² This report is available, in German, in L. Burgerstein's *Schulhygienische Untersuchungen*. Hamburg, 1889. See also F. Burk, *Growth of Children in Height and Weight*, *Amer. J. of Psych.*, 9: 1897-1898, 253 ff., esp. 286-295.

symmetrical and proportionate increase in size of the body as a whole. It is tempting, and doubtless justifiable, to suppose that the central nervous system likewise matures unevenly and that we have a corresponding growth by parts in mental life, with nascent periods for specific traits and capacities.

Growth of the Bones.—The bones grow longer and thicker and undergo important changes in their constitution, particularly noticeable in the completion of the process of ossification,¹ *e.g.* in the bones of the skull, and in the joining of the epiphyses of numerous important bones, *e.g.* the humerus, femur, tibia, scapula.

The bone growth of puberty is not simple enlargement, but, in many instances, involves alterations in shape and proportions. Thus, chest growth is chiefly in a lateral direction; growth in height is largely due to lengthening of the thigh bones; the pelvis, at least in girls, is greatly modified in shape; in the head, the face lengthens by as much as an inch; the interocular distance increases as the face broadens; the second dentition is completed; the lower jaw becomes heavier, the nose longer and more prominent, while the nasion fills in. These changes combine with changes in muscular development to bring about decided changes in facial expression.

Hygiene of Bone Growth.—Apparently, the system demands a special supply of mineral matter, particularly of lime, at this time. This demand is usually held to account for the “lime-hunger” of pupils who eat chalk, and even plaster of Paris or mortar. Too rapid growth of the bones is also held to account for “growing pains,” either because the epiphyses, or centers of growth in the bones, become inflamed, or

¹ It has been proposed to use this phenomenon as a basis for the classification of children into different physiological ages. The work thus far done, however, applies primarily to infancy and childhood up to the twelfth year. For X-ray photographs of the progressive ossification of the small bones of the wrist, see T. M. Rotch, M.D., *Roentgen Ray Methods Applied to the Grading of Early Life*, *Proc. 4th Cong. Amer. School Hyg. Assoc.*, 1910, pp. 184-208.

because the bones grow faster than the muscles and thus cause abnormal tension and perhaps interference with the blood supply. Since bone growth is affected by posture and muscular strains as well as by nutritive supply, it follows, according to Hall,¹ that "too high pillows, sleeping in one position, ill-adjusted seats at school or on the bicycle, lacing, occupations that strain or require unnatural postures, are especially to be avoided at this age."

Growth of the Muscles. — The muscles participate extensively in the rapid growth of puberty; thus, at 8 years they form 27.2 per cent of the total body weight, but at 15 years, 32.6 per cent, and at 16 years, 44.2 per cent. The clumsiness so characteristic of adolescent boys is perhaps due in part to inequalities of muscle growth, either because the muscles grow faster than the bones to which they are attached or because the musculature develops at an unequal rate in its various parts.

Growth of Heart and Arteries. — The heart muscles increase in size and in number of contractile fibers, so that the volume of this organ is radically increased in proportion to the lumen of the arteries through which it forces the blood — the ratio of heart to arteries being 25:20 at birth, but 140:50 at puberty and 290:61 at full maturity, according to the measurements of Landois. The effect of this growth of the heart is in all probability to produce a heightening of blood pressure at puberty, and there is evidence that the earlier and more decided this growth, the earlier, stronger, and more complete is the development of puberty.

These changes in arterial pressure, together with changes in the specific gravity of the blood (at least in girls) and the slight rise in bodily temperature (about 0.5° F.), are all tokens of the extension of the circulatory system to supply new structures and new bodily functions, of the need of irrigating an increased musculature, and of the increase of metabolism

¹ *Adolescence*, Vol. I, p. 82.

(assimilation and dissimilation of tissue) connected with the general physiological "stir-up" of the period.

Circulatory Disturbances. — Like all the other phenomena of adolescent growth, there is here, too, a noticeably increased individual variation, while temporary functional disturbances are not at all uncommon. Sudden and unaccountable fluctuation in the rate of the pulse, palpitation of the heart, and frequent or habitual headaches are often reported during pubertal growth. The anemia and chlorosis (green sickness) of adolescent girls are other all too characteristic functional disturbances of adolescence. Thus, Key found habitual headache in 13.5 per cent of boys and 36.1 per cent of girls and symptoms of chlorosis in 12.7 per cent of boys and 35.5 per cent of girls. Somewhat smaller percentages are reported by Hertel from the examination of children 11 to 14 years old at Copenhagen.

Growth of the Lungs. — Though the growth of the heart tends to lessen the chest capacity, this reduction is more than compensated for by the enlargement of the thoracic cavity already mentioned. By means of the spirometer, measurements may be taken of the "breathing capacity,"¹ — also termed the "differential capacity" or the "vital capacity," — *i.e.* the maximal amount of air that can be exhaled after a maximal inhalation. This capacity, taken by itself, or expressed in its relation to bodily weight (the "vital index"), furnishes a valuable index of general vitality. Measurements of school children show that the vital capacity of girls increases rapidly from 12 to 14, thence slowly until 20, while that of boys increases rapidly from 14 to about 19.5 years.²

Training for Vital Capacity. — Vital capacity, perhaps more than any other physical capacity, may be greatly in-

¹ When the estimated air remaining in the lungs, the "residual air," is added, the total gives the "lung capacity."

² See G. M. Whipple, *Manual of Mental and Physical Tests*, 1914, Test 5.

creased by suitable exercise and training. Since, then, full development of chest and lung is so obviously desirable (as an adjunct in endurance under effort, in resistance to disease, etc.), the physical training work in every secondary school should be so arranged as to secure maximal chest development and habitual good bodily posture.

Changes in the Voice. — Just as the cries, clucks, chirps, and all the other various equivalents of voice found in animals may be observed to alter at the mating season, or perhaps to be heard only then, so, too, alteration in voice is one of the most obvious and characteristic symptoms of the pubertal period.

In boys the growth of the larynx, outwardly visible in the increased prominence of the Adam's apple, with the correlative elongation of the vocal cords to about double their former length, produces a drop in the pitch of the voice of approximately an octave. In girls a similar, but less marked, change may be noted: the drop in pitch is slight, but the change to a richer and fuller timbre is unmistakable.

Period of Mutation. — In boys this process of "mutation," as it is termed, may begin as early as 12, or not for three or four years later. As it ordinarily takes about two years for the voice to become established in the lower register, some boys may sing treble even up to the age of 19. During mutation the voice is often rough and hoarse and characterized by the well-known "breaks" in pitch. Hall thinks that, with the structural alteration of the vocal organs, there appears "a new vocal consciousness," and that pubescent boys delight to experiment with their voice, especially "to yell and indulge in vocal gymnastics of a drastic kind."

Hygiene and Training of the Voice. — The desirability of using the voice in singing during its mutation has been a matter of debate among teachers of vocal music. Paulsen found that 75 per cent of adolescent boys could not control

the voice during mutation, but MacKenzie¹ examined 500 choir boys 14 to 18 years old and found the voice really "cracked" in only 17 per cent. The best opinion appears to coincide with the conclusion of Dr. MacKenzie that singing may be continued if due care is exercised, especially in avoiding very high or very low registers.

At any rate, a reasonable amount of voice culture seems to be needed in the secondary school to secure a satisfactory speaking voice. Too often the voice settles into an undesirable pitch and color; it becomes nasal, throaty, coarse, or in girls shrill and grating, and enunciation is defective. Teachers should set a persistent good example and encourage their pupils to think how they sound as well as how they look!

Growth of the Brain. — The brain, unlike most of the bodily organs, does not increase much in weight at adolescence. However, the manifold alterations and augmentations in psychic life — the new instincts, feelings, ideals, motives, and the general ripening of intellectual grasp that make up the psychological picture of adolescence — point unmistakably to corresponding alterations in brain activity. These alterations may be in part the functional maturing of cells and tracts hitherto dormant, and in part the extension and ramification of the fiber processes of cells already mature, particularly in the "higher" association areas of the cortex. The one development would account for the awakening of new instinctive tendencies, the other for the enriching and elaboration of mentality in general.

THE PSYCHOLOGICAL PHENOMENA OF ADOLESCENCE.² — The most prominent instinctive responses of

¹ Morell MacKenzie, M.D., *The Hygiene of the Vocal Organs*. London, 1886, p. 130.

² METHOD OF STUDYING ADOLESCENCE. — A word may be said concerning the method of studying the psychology of adolescence. Our present knowledge of this field is due almost entirely to the labors of Stanley Hall, who, with the aid of his confrères and graduate students at Clark University, has collected thousands of observations by the circulation of series of questions. The questionnaire,

childhood, fearing, feeding, fighting, and the like, make for self-preservation. The child naturally "looks out for number one"; his conduct is ego-centric; he is, from an adult point of view, intrinsically selfish. But to Nature the individual counts for little, the race for much. Self-preservation may be the "first law of human nature," but species-preservation is the first law of Nature.

We have seen how, during puberty, the body becomes physically prepared for participation in this species-preservation. We must now see how, during the same period, mental reconstruction yields a new attitude toward life — an attitude which is, in large measure, clearly directed to the same general end as the physical reconstruction.

Primary and Secondary Sex Characters. — The biologist distinguishes between structures or traits that are directly and immediately concerned in the process of reproduction and other structures or traits that are merely accessory or assisting; the former are termed primary, the latter secondary sexual characters. Thus, the odor or color of a flower, for example, is a secondary character that serves to attract insects and brings about fertilization by pollen grains (the primary sex characters).

Analogously, the mental processes correlated with the development of sex during adolescence may be regarded as including not only those that are primary to sex, like sex love and impulses toward sexual activity (*libido*, in the scien-

or questionnaire, is, as its name implies, a list of questions, usually printed, to which answers are sought from a considerable number — say, several hundred — of persons. The replies, or "returns," are then collated, and from them inferences are drawn. The method has the advantage of numbers — 200 experiences afford a truer picture of human nature than do two or half a dozen — but it has defects; 200 poor answers by writers incapable of reliable report, or seeking to please the questioner, or unconsciously suggested by the phrasing of his questions — 200 such answers are inferior to half a dozen reliable observations. It is not improbable that some of the generalizations now current about the psychic life of adolescents are unwarranted and will be replaced in time as more critical and exact information becomes available.

tific terminology), but also a host of other processes that are secondarily or indirectly associated with the emergence of the sex-consciousness.

Ramifications of the Sex Instinct in Mental Life. — Thus, interest in adornment, "showing-off," widening consciousness of social relations, altruistic conduct, æsthetic appreciation, religious conversion, and desire for travel, to cite instances, represent varied and characteristic mental experiences of adolescence, all of which may be traced back to sex, in the widest meaning of that term. Not, of course, that the sex instinct is alone responsible for these manifestations, or that the adolescent is even conscious of a connection between them and his sex life, but only that the chief driving agency behind them is, after all, the sex instinct. To use the fruitful metaphor of Stanley Hall, we may think of these secondary or indirect manifestations as "long-circuitings" or "irradiations" of the sex instinct, and the problem of the psychology of adolescence becomes primarily that of cataloguing and describing them. Or, to use the terminology of the followers of the Vienna physician, Freud, — who has given us an elaborate account of the genesis and development, particularly in aberrant ways, of these sex manifestations, — we may speak of these remoter manifestations as "sublimations" of the sex impulse.

Sensory Development. — The uncertainty in data and inferences based on the questionnaire method is well illustrated in the statements commonly made as to the effect of adolescence upon sensory development. On the one hand, laboratory experiments do not indicate any marked or widespread "sharpening of the senses" during the period.¹ The best data obtainable show, for instance, that auditory acuity reaches its maximum at 12 years; that visual acuity tends all too often to deteriorate as a consequence of myopia, hyperopia, and astigmatism; that the discrimination of two

¹ For detailed statements, see Whipple, *op. cit.*, Chap. VI.

points on the skin (the æsthesiometric index) is poorer at maturity than at childhood. Sensitivity to pain decreases up to 18 or 19 years, with irregularities at puberty. Pitch discrimination apparently does not improve after the 10th year, nor the discrimination of lifted weights after the 13th year.

On the other hand, the frequently quoted results of Lancaster's questionnaire¹ are taken by many writers to mean that the senses grow keener during adolescence. But when a girl of 17 testifies that she now hears the chimes three miles away that she never heard as a child, when another asserts that her eyesight was keenest at 13, as tested by seeing a steeple in the distance, and another that all nature took on a "new aspect of beauty" at this period, and when Hall speaks of "a new dermal consciousness," etc., it is evident enough that the adolescent modification is central, not peripheral. What is changed is not the cochlea or the retina, but attention, interest, feeling, and emotion. In short, adolescence affects the attitude toward sensation, not sensation itself.

New Dermal Consciousness.—Take, in illustration, the "new dermal consciousness" just mentioned. The sweat glands and sebaceous glands apparently become more active during puberty. The skin is more oily. Concern as to personal appearance may impel the girl to an altered regimen of bathing, to the use of cosmetics. Pimples and eruptions, characteristic of the period, solicit attention. Some purposely abrade the skin; others try to pull hair from the eyebrows, cheeks, and other parts of the body, despite the pain. Primitive people indulge in tattooing at this time. Then appear strong likes and dislikes for covering parts of the body, arms, neck, hands, head, etc., with clothing. Contact with the skin of others, as in hand-shaking, stroking, caressing, kissing, may be sought after and enjoyed, or strongly disliked and shunned. All this elaboration of the "skin conscious-

¹ E. G. Lancaster, *The Psychology and Pedagogy of Adolescence. Ped. Sem.*, 6: July, 1897, 61-128, esp. p. 79.

ness" is centrally, not peripherally, determined; it is, in reality, closely related to the ripening of sex functions, as Freud¹ has shown. Hall believes that the leading of a rugged life, with abundant skin stimulation, even with plenty of pain stimuli, is desirable to keep attention from being focalized on sex.

New Smell and Taste Interests. — Questionary returns show a similar emergence of new interests in odors. Girls develop fondness for perfumed soaps, sachet powder, smelling bottles, etc. Likes and dislikes for people are frequently reported to be based upon real or fancied odors; friendships are broken on account of a bad breath, and so on.

Taste and smell, in combination, give us flavor, and reaction to flavor determines likes and dislikes for various foods. Data from questionary returns indicate both a widening of the range and a greater caprice of appetite during early adolescence. Many articles of food are now used for the first time, and few new dishes are "acquired" after this period. Naturally, extreme likes and dislikes are to be curbed, especially when they tend to undermine health, *e.g.* overindulgence in tea, coffee, condiments, and sweets. Adolescents not infrequently become faddists, and pursue certain diets, *e.g.* vegetarianism, religiously for a time. Hall is of the opinion that this widening range of appetite at adolescence may be a recapitulation of the age in primitive peoples when youth cut loose from parental support and began an independent life of food getting, but this surmise is as questionable as any other that hinges upon acceptance of the doctrine of psychic recapitulation.

New Aural Interests. — With the change of voice at adolescence, there is, as we have noted, a "new vocal consciousness." Likewise, there appears an undeniable aug-

¹ S. Freud, Three Contributions to the Sexual Theory. (*Nervous and Mental Disease Monograph Series*, No. 7), New York, 1910, especially the third essay: "The Transformation of Puberty."

mentation of interest in music — both intellectually in growth of real musical appreciation and understanding of musical forms, and emotionally in delight in music. Of 556 adolescents who answered Lancaster's questionnaire, 464 testified to an increased "love of music." The evidence for this nascent period is fairly clear, and it appears to reach its climax at the 15th year. At this time, many boys and girls, who are in reality unmusical, pass through a period of transient devotion to music, purchase instruments, and begin to "take lessons," especially on stringed instruments (banjo, mandolin, and guitar). Those who have real talent make surprising progress at this time; the others soon lose their zeal.

Here, again, and in the similarly augmented interest in color, displayed in dress, in painting lessons, etc., we have an example of the enrichment of sensory life by the indirect ramification of sex instinct. The real adolescent growth is not in sensitivity and sense discrimination, in the strict psychological sense, but in the emotional background, and the appeal that stimulation of skin, tongue, nose, ear, and eye makes to the strong undercurrent of life interests of the period. Pedagogically, the main problem is the utilization of this "awakening" for the higher processes of mental development, particularly the turning of these biologically determined impulses toward artistic and creative effort of a worthy kind.

The Sex Instinct. — The most fundamental psychic phenomena of adolescence is, however, not in the sphere of sensation, or the emotional reaction to sense-impressions, but rather in the sphere of instinct. The sex instinct has been commonly regarded as a typical latent or delayed racial tendency, as practically totally lacking in childhood and appearing relatively abruptly at puberty. In a way this is true. The young child naturally exhibits little physical self-consciousness, little instinctive concealment of sex shame, whereas, at puberty, there appear bashfulness, coyness,

“showing off,” strong personal interest in individuals of the opposite sex, and a flood of vague impulses and emotional reactions to sexual stimuli. Some authorities go so far as to assert that for some years at this time fully nine tenths of the mental processes of adolescents center in sex and its functions — if we give to the term a broad interpretation.

On the other hand, however, the work of Freud and his followers has laid emphatic stress upon the principle that the remoter beginnings of the sexual life date far back into childhood and even into infancy, so that these pubertal phenomena are transformations or realignments of earlier instinctive tendencies rather than new and hitherto-absent tendencies.¹

Sex Charms and Fetishes. — In the emergence during puberty, and the subsequent development, of attraction for the opposite sex, there is exhibited an interesting and characteristic example of that “long-circuiting” or indirect ramification of the instinct to which we have already alluded. It is this: sexual attraction or repugnance tends to be aroused less by the primary sexual characteristics than by secondary or remoter characteristics. Likes and dislikes, in other words, are based upon seemingly trivial details of personality, e.g. color of eyes or hair, manner of walking, quality of voice, contour of neck, and so on — all traits which do not, in the last resort, affect in one way or another the value of their possessor, considered biologically as a contributor to the perpetuation of the species, yet traits which constitute the basic material of romantic love.

Where, as is often the case, some one trait or combination of traits becomes the focus of interest and admiration, or, as it is phrased, gains “special erogenic power,” to the exclusion of other traits and qualities, we term it a sex fetish. Investigators have collected and classified these fetishes by asking young men and women what particular traits they regarded as essential in determining likes or dislikes for persons of the

¹ See Freud, *op. cit.*

opposite sex.¹ The results are most striking. Bodily traits are cited in the order: eyes, hair, stature, feet, brows, complexion, cheeks, throat, ears, chin, hands, neck, nose, etc. Movements and actions are equally prolific sources of sex fetishes, e.g. the voice, mode of laughing, carriage, gait, gesture, pose of head, etc. Attraction may also center in dress or personal adornment — white linen, furs, collars, glasses, ribbons, sashes, etc.

Equally intense aversions may reside in specific traits, e.g. prominent or deep-set eyes, full neck, ears that stand out, eyebrows that meet, large feet, pimples, red hair, giggling, swaggering, flashy neckties, untidy linen, colored handkerchiefs, or resemblance to certain animals — monkey, dog, parrot, pig, peacock, etc.

In all the instances of attraction, these traits become charms dissociated from sex centers (or perhaps rather symbolic of them) and objects of direct attraction. This focalization of the sex attraction upon specific traits, often in themselves trivial, varies in individual adolescents, both in quality and in degree, but the tendency is decided and clearly enough exhibited by most adolescents, especially in the early portion of the period. As maturity approaches they may suffer modification and even reversal, so that the young boy who worships golden hair in his teens may, after all, succumb to a complex of other qualities in a pronounced brunette.

The Development of Love. — The appearance of these sex charms and fetishes is but one phase of the development of the sentiment of love. Not even this romantic and poetic phase of human nature has escaped the analysis of the man of science, and we have several accounts, primarily based upon the questionnaire method, of the normal development of love. Bell,² for example, distinguishes five fairly representative stages.

¹ Hall, *Adolescence*, II, 113 ff.

² Sanford Bell, A Preliminary Study of the Emotion of Love between the Sexes. *Amer. Jour. of Psych.*, 13: July, 1902, 325-354.

(1) The "love" of childhood, of boys and girls under the age of 8, — a sort of Platonic, sexless, transparent childhood attraction, characterized by fondness for one another's company, exchanging keepsakes, etc. These attractions are commonly transitory and free from danger if not carried too far.

(2) Juvenile love, or "liking," during the years 8 to 12, is more secretive and self-conscious. This is the stage of motto candy, and valentines, and such behavior as Whittier has wrought into his poem "In School-Days." Teachers sometimes successfully utilize these juvenile attractions as an incentive for better work and conduct in the schoolroom.

(3) From 8 to 13, or later, there may be displayed a psychologically interesting stage in which affection is exhibited for older persons. Though sometimes abnormally strong, and then a perverted and perhaps dangerous development, this tendency is to be looked upon in the main as natural and not unproductive of good, especially for the younger party. Very common in this connection is the sentimental affection developed by boys in the grades or early high school years for women teachers — an affection which may exert a powerful determination upon the ideals, incentives, and conduct of these pupils. The fact that this attraction for older persons may focus upon an individual of the same sex (and not mere liking, but actual passionate love) lends countenance to Hall's suggestion that the root of the sentiment may be an admiration for maturity itself. Because most schoolboys are confronted with women teachers, the attraction happens, for them, to be often hetero-sexual. Some observers believe that a rough rule may be laid down to the effect that the sum of the ages of the two persons remains approximately constant, *i.e.* the younger the one party, the older the other. This stage shows, at least, how fundamental and how wide in scope are the sentiments and impulses of the period.

(4) A fourth stage, assigned to the beginning of puberty,

seems to the writer less clearly manifested. In it, it is asserted, there is a temporary drawing apart of the sexes, as modesty and sex reserve develop, and the interests of boys and girls tend to diverge. Boys want to assert their manhood and are ashamed of the inexplicable weaknesses betrayed in their juvenile loves.

(5) In the final stage conscious sex love slowly emerges, gradually taking on fuller richness and meaning as physical and mental maturity is attained.

Instruction in Sex Hygiene. — Sex hygiene may be regarded as primarily concerned with securing a normal and wholesome development of the sex instinct, though the field that it opens for discussion presents physiological, ethical, and sociological, as well as psychological problems. The past few years have been attended with vigorous discussions of the feasibility of instruction in matters sexual, and an extensive literature has accumulated.¹ These discussions concern four main queries: why, by whom, when, and how?

Why? — Children possess a natural curiosity concerning the origin of life, birth, difference between the sexes, functions of sex organs, and the significance of the bodily changes observed in themselves at puberty. They have a right to know about these things. Correctly given instruction in sex hygiene certainly tends toward the securing of a healthful sexual

¹ An excellent indication of the interest manifested in the problem and of current views on the subject is to be found in the symposium on The Problem of Sex-instruction, *Journal of Education*, 75: March 21, 1912, 313-323. The writer has summarized some of the recent literature in the *Journal of Educ. Psychol.*, 2: October, 1911, 464-470. In the same issue will be found a good survey of the problem by W. S. Foster, School Instruction in Matters of Sex, 440-450, and a description of an actual high school course, by W. H. Eddy, An Experiment in Teaching Sex Hygiene, 451-458. Teachers may secure, at nominal sums, by addressing the Society of Sanitary and Moral Prophylaxis, 9 East 42d St., New York City, a series of six *Educational Pamphlets* of value. The same organization publishes a series of *Transactions* and a *Journal of Social Diseases*. Some important papers on sex hygiene will be found in Vol. II, No. 4, October, 1911, issue. For an extended discussion, see Havelock Ellis, *Psychology of Sex*, Vol. 6.

development, and on this hinges healthful physical, mental, and moral development. The "policy of silence," which has been predominant in this country in the past, and which is still favored by many parents and teachers, is absolutely indefensible, as any one fully conversant with the facts knows full well. The child's curiosity drives him to secure information where he may find it, and he usually secures it from playmates in a filthy, misleading, and reprehensible form. Lack of early instruction is the primary cause of bad personal habits. It is responsible for the pathetic anxiety and worry of numerous adolescent boys and girls, who fear that the symptoms of pubertal change that they see in themselves are abnormal, frequently become the prey of quack "doctors," and may even be driven to contemplate suicide on that account.¹ Lack of instruction is responsible, too, at least in part, for youthful immorality. "Girls who go wrong" often blame their parents. Schoolmen have unearthed most appalling conditions in some high schools. Finally, lack of instruction is responsible, in part, for the frightful spread of venereal diseases.² It is surely worth while to incur whatever slight risks may attend the giving of instruction to the young if these calamitous evils may be in some measure counteracted. By Whom? — Ideally, sex instruction should be the welcome task of parents. In practice, parental instruction is a failure. In many cases the parents are themselves incompetent to give the instruction. More often they do not attempt it on account of false modesty. To them sex is "taboo." They repress the first questionings of their children and erect insurmountable barriers to further approach. The child soon learns to refrain from direct inquiry.³ Yet other

¹ Hall, *Adolescence*, I, 459-463.

² See particularly, W. L. Howard, M.D., *Plain Facts on Sex Hygiene*. New York, 1910.

³ On the disastrous effects of this undermining of the faith and intimacy of parent and child, see Ernest Jones, M.D., *Psycho-analysis and Education*. *Jour. of Educ. Psych.*, I: 1910, 497-520.

parents intend to inform their children, but put off the day of enlightenment until conversation is too difficult or it is too late.

In some quarters, especially in Germany, the church or the clergy have claimed the prerogative of guiding sexual development in youth, but no serious, systematic, or extensive movement for allying sexual with religious instruction is to be discerned in this country. It would be predestined to failure, partly because the minister is too distant in his relations with his congregation, partly because he is incompetent properly to instruct children in these matters. He can, of course, perform a valuable indirect service by his appeal for moral conduct, self-respect, and high ideals.

The family doctor has also been thought by some to be the natural agent of sex instruction, but here, again, both pedagogical skill and personal intimacy are wanting.

The school, then, remains as the best practical agency. The school undertakes the general physical, mental, and moral training of the child; why should it not include this particular aspect? ¹ The teacher has pedagogical skill; the teacher knows the child. The child looks to the teacher for guidance. Reproduction may be studied perfectly logically in physiology and biology, and the basis for special instruction may there be firmly laid.

When? — Opinions differ as to whether instruction in sex should be left till the time of puberty or not. The chief argument for postponement is the plea that unnatural precocity will result from early instruction, and the desire to keep the child in "blessed ignorance." The arguments for prepubertal instruction are much weightier. More pupils may be reached in this period if the instruction is given in the school. Instruction is easier then, for both teacher and child. Adults are seldom able to realize how much less self-conscious than themselves are children who have not reached their teens.

¹ See Jones, *op. cit.*, p. 515, and C. W. Eliot, School Instruction in Sex Hygiene, *Proc. 5th Cong. Amer. Sch. Hyg. Assoc.* New York, 1911, 22-26.

Again, a prime reason for early instruction is the fear of the evils that may follow deferment. As Dr. Blom says: "Better a year too early than an hour too late." Finally, experience has demonstrated the feasibility of early instruction. The alleged precocity does not develop if the instruction is properly given.

How? — If we admit that sex instruction should begin in the prepubertal period and extend through the pubertal period, the method and material of instruction fall naturally into two parts. During the first, or prepubertal, period, which would naturally coincide with the elementary school, instruction should be straightforward, objective, factual, and essentially scientific in vein, and should be incorporated mainly in the teaching of physiology, nature study, and personal hygiene. If this work could be based upon, and supplemented by, home instruction, so much the better.¹

In the second, or pubertal and postpubertal period, *i.e.* in the secondary school, instruction should take on a more personal and subjective tone and be presented with a strong ethical and social emphasis. Just what should be given and what not given is still a matter of debate, and the whole pedagogy of sex hygiene is yet in the experimental stage. Much depends on the local situation and on the skill and personality of the teacher. Thus, it is debated whether reference to the pathology of sex, particularly to venereal diseases, their nature and spread, is desirable or undesirable. A middle course would seem to be indicated. To secure right conduct in sex as in other matters we need to use both positive and negative incentives.²

¹ Suggestions for a graded course of prepubertal instruction will be found in B. Talmey, M.D., *Genesis: a Manual of Instruction of Children in Matters Sexual* (New York, 1910), Part II, though some of the material there proposed seems too difficult for the ages to which it is assigned. Consult also Clara Schmitt, *The Teaching of the Facts of Sex in the Public School*, *Ped. Sem.*, 27: June, 1910, 229-241.

² In favor of warning against venereal diseases is, of course, the hope that it will serve as a powerful deterrent against yielding to temptation. Thus Howard

Also debatable is the question whether instruction should be occasional or systematic, optional or prescribed, to separate or to mixed classes, by physicians or by regular teachers. Neither is it clear how much value is to be gained from the circulation of "books of warning," as they have been termed.¹ The experiences reported by W. H. Eddy² and by Jessie Phelps³ show that it is perfectly feasible to arrange a well-organized and successful course in conjunction with the work in biology.

The Migratory Instinct. — The sex instinct is one factor in that complex impulse to seek new surroundings, to exchange the routine and the familiar for the fresh and the unknown, which is termed the migratory instinct. Thus, the migrations of animals are partly impelled by food-getting, partly by climatic conditions, but partly also by the approach of mating and breeding seasons. And in children, though the running

(*op. cit.*, p. iii) writes: "The fearful havoc the diseases explained in this book are making among the innocent is due to ignorance. It is my purpose in this book to destroy forever this injurious ignorance. This is the only way to stop the increase of the curse that is over all the land." Similarly, Talmey recommends instruction on menstruation, pollution, and masturbation to children 13 to 16 years of age, and instruction on gonorrhoea, syphilis, and continence to children 16 to 18 years of age. Divergent views are expressed by Dr. Richard Cabot (*The Consecration of the Affections* — often misnamed *Sex Hygiene*. *Proc. 5th Cong. of the Amer. Sch. Hyg. Assoc.*, New York, 1911, pp. 114-120) and by W. D. Parkinson (*Sex and Education*. *Educ. Rev.*, 41: January, 1911, 42-59), who question whether we can create virtue by dwelling on vice, and think it bad morality to preach virtue for fear of the consequences of sin. Parkinson's article closes with a very suggestive set of questions which will repay consideration.

¹ These are abundant enough, but not always of the type to be desired — straightforward, cautious, and impressive without being sentimental. Good examples are E. Lyttelton, *Training of the Young in Laws of Sex*, London, 1900, and two books by Dr. Edith B. Lowry, *Confidencess: Talks with a Young Girl concerning Herself* (Chicago: Forbes & Co., 1910) and *Truths: Talks with a Boy concerning Himself*, 1910.

² *Op. cit.*

³ Biologic teaching of sex. *Trans. 1st. Ann. Meeting Amer. Assoc. for the Study and Prevention of Infant Mortality*. Baltimore, 1910, pp. 291-296. (Reviewed in *Jour. Educ. Psych.*, 2: 1911, 464-470.)

away from home, which often begins as soon as walking is learned, has doubtless various motives, conscious or sub-conscious, yet the tendency is certainly stronger in the spring than at other seasons (so that our "spring fever" probably has some biological significance) and stronger at adolescence than at other ages.¹ So Kline² has found that the "curve" of "love of adventure" rises rapidly to 10, and steadily thereafter to 19, and has shown a clear nexus between truancy and the migratory instinct; and Brooks³ in his suggestive study on withdrawal from school found that "desire for activity" is a peculiarly potent factor at the dawn of adolescence. Naturally, this characteristic restlessness of adolescence need not manifest itself in actual truancy or running away from home. But parents know full well how, with the widening circle of acquaintances and the widening range of interests that the high school entails, their sons and daughters grow less and less home-bodies and are more and more caught up in the bustle and activity of life outside their own fold. The fact that the yearning is so often a veritable *Wanderlust* raises the question whether the school might not turn the tendency to good account by arranging collecting trips, school excursions to points of industrial, historic, geologic, or geographic interest, providing lectures on travel and life in foreign countries, or by encouraging camera clubs, walking clubs, vacation tours, and the like.

It is unfortunate that we have in America no such organized trips for pupils as have long been regular features of

¹ The writer has found that in college classes those men who have not run away from home one or more times during their high school period are generally in the minority. The essentially instinctive character of the motivation is evident both in the frequency of the occurrence and in the fact that there is really no clear reason or necessity for the going in most instances; the impulse often seizes suddenly upon boys whose home conditions were most happy.

² L. J. Kline, *The Migratory Impulse vs. Love of Home*. *Amer. Jour. of Psych.*, 10: 1898, 1-81.

³ S. D. Brooks, *Causes of Withdrawal from School*. *Educ. Rev.*, 26: 1903, 362.

German school life. With us points of interest appear to be too far apart; the cost of travel is perhaps too great; we lack the convenient inns. A beginning has been made, however, in some parts of the country; some schools in central New York have arranged walking trips through districts of historic interest in their vicinity; excursions of graduating classes to Washington have also become common. Similarly, competent instructors have taken groups of boys on bicycling trips of a week or more, under the auspices of the Y. M. C. A. The recent Boy Scout movement also provides for various expeditions.

THE SOCIAL ASPECTS OF ADOLESCENCE. **The Social Instincts.** — The sex instinct in all animals leads to association for longer or shorter periods (mating and breeding seasons), and when the young have a distinct period of infancy (with attendant helplessness), the need of parental care may prolong the association or lead to something like family life. In human beings adolescence marks the ripening of a number of racial tendencies known as the social or group instincts. Among these tendencies are the seeking to be where other persons are (gregariousness, need of society), seeking to win the good will of others (love of approbation, need of "getting-on" with people), and seeking to help or assist others by positive service (altruism, self-sacrifice). We do not need to assume that these instinctive responses to the situations of daily life are seen only during or after puberty, or that they are manifested in the same way by all adolescents, or that no other causes conspire to elicit them than the biological upheaval of puberty. The essential thing is that these types of feeling and behavior are normally intensified as the body assumes preparedness for the functions of racial perpetuation. Compared with the relatively self-centered life of the child, the life of the adolescent is shot through with consciousness of self as related to other persons. His outlook is hetero-centric, not ego-centric. His behavior

has constantly a social reference. He considers himself in relation to others.

It needs no argument to show how important these social tendencies are from every point of view. On their successful development and utilization depend the last and perhaps most significant advances in mental development. Failure to make these high adolescent adjustments is the cause of much inefficiency, failure, and misery.¹ The skillful secondary-school teacher sees in them both the cardinal problem of adolescent moral training and the means whereby, if at all, this training may be realized. A brief survey of these tendencies will, then, enable us to discuss their utilization in the school.

Gregariousness. — The assumption of these new attitudes is not the work of a moment. On the contrary one sees a vacillation between the childish and the youthful attitudes. The readjustment takes time, and contradictory behavior appears. Thus, in the case of gregariousness, many young adolescents, particularly boys, pass through a stage of what is almost a fear of society, characterized by bashfulness, diffidence, extreme self-consciousness, clumsiness, blushing and dread of committing some *gaucherie*. This anti-social attitude is shown primarily in the presence of the opposite sex, and probably more often by those who are brought up alone,² or whose conduct has been the subject of too much criticism or censure by parents or friends.

Sympathy. — Another phase of the social tendencies, perhaps sufficiently definite to be classed as a specific instinct, is that disposition to enter appreciatively into the lives and especially into the misfortunes of others — in other words, to be sympathetic. A sort of pseudo-sympathy develops in

¹ E. B. Huey, Retardation and the Mental Examination of Retarded Children. *Jour. of Psycho-Asthenics*, 15: 1910, 31-43.

² E. W. Bohannon, The Only Child in a Family. *Ped. Sem.*, 5: 1898, 475-496.

very young children, but genuine sympathy is rarely displayed before adolescence. On it evidently depend a number of important ethical traits and activities, like kindness, benevolence, charity, and philanthropy. Moral training in the secondary school must aim to ensure an adequate development of these essential social virtues.

Approbation. — The inclination so to act as to win the approbation of others is obviously enough applied to instincts underlying courtship. But, by extension, the adolescent wants also to win the approval of others than the individual of the opposite sex who serves as the special object of attraction. The adolescent wants to make a name for himself, to feel that he has the good opinion of parents, teachers, and schoolmates.¹ That indefinable something we call “public sentiment” now has profound weight. “Social pressure” has now a real significance. What the adolescent eats, wears, says, and does is largely determined by what he thinks other people will approve. Boys and girls do this and that because “it is the thing.” Needless to say that this tendency may prove a powerful lever in the hands of the teacher. “Children thus often become what their teachers believe them to be, and many a boy has been saved by the faith reposed in him by teacher, parent, or friend.” But the same tendency may, of course, become an equally powerful determiner for evil if the wrong kind of approval be sought for: a criminal might rejoice in being esteemed the toughest member of his “gang.”

Sometimes this desire for approbation is abnormally strong, so that the adolescent has an almost morbid dread of antag-

¹ In asking college students what incentives motivate their daily work, I have been struck with the uniformly high place accorded such factors as “Desire to please my parents,” and “Desire to stand well in the opinion of my friends.” These motives are, I judge, more potent in maintaining effort through the labor of daily tasks than the remoter incentives like “Desire to be of service to mankind,” “Desire to get a good position,” or “Desire to acquire a thorough knowledge of the subjects I am studying.”

onizing his associates: he assents to all their opinions; he effaces himself completely, and becomes a sort of social parasite.¹

Altruism. — Altruistic tendencies add one more step to the progress of socialization, for they impel the adolescent not only to associate with others, to sympathize with them, and so to act as to insure their approbation, but also to perform positive service for them, at his own discomfort or disadvantage. This trait is not one to be gained in a moment. Altruistic conduct may alternate with utter selfishness. Indeed, paradoxical as it may seem, genuine selfishness may be more evident in adolescence than in childhood. The self-centered career of the child is natural and instinctive, whereas the adolescent chooses between conflicting tendencies, and if selfishly, then in the face of his appreciation of duty and obligation to others. But, in general, adolescence is, as Hall says: "The great period in life for devotion to others, especially in self-sacrificing causes. Pledges, agreements, vows, and other restrictions on one's freedom are made at this period with a joyous enthusiasm." As we shall see later on, these altruistic tendencies lie at the root of the proclivity of adolescents to indulge in various forms of philanthropy, to champion reform movements, and to plan careers of social service.

Self-organized Groups. — If we turn now to concrete instances of the operation of the social tendencies, perhaps first in order is the instance of self-organized groups, or "gangs." Sheldon² found that 851 of 1034 boys would admit member-

¹ Probably this disposition accounts for certain cases of apparent religious conversion, with subsequent backsliding. Social pressure, personal appeal of pastor, parents, or friends, and the highly emotional setting make a combination of great suggestive power while it lasts.

² H. Sheldon, *The Institutional Activities of American Children*. *Amer. Jour. of Psych.*, 9: 1898, 425-448. See also W. B. Forbush, *The Boy Problem* (4th ed. Phila., 1902), and T. J. Browne, *Boys' Gangs*. *Association Outlook*, 8: 1899, 96-107. Louis D. Hartson, *The Psychology of the Club: a Study in Social Psychology*. *Ped. Sem.*, 18: September, 1911, 353-414 (with bibliography of 89 titles.) J. A. Puffer, *The Boy and his Gang*. Boston, 1912.

ship in some such rudimentary society. The years 10 to 17, particularly 11, 12, and 13, are those in which membership is commonest. The motives and activities of these societies are of evident interest to teachers and parents who would understand and control them, or who would themselves organize or direct societies for young adolescents. Of 123 spontaneously formed societies, Sheldon found the prevailing motive (in 61 per cent) to be athletic, with another phase of physical activity, the predatory — hunting, fighting, camping out, etc. — next in order (17 per cent). On the other hand, industrial, philanthropic, literary, artistic, and merely social purposes are all less frequently exhibited. It appears that the moral tone of these organizations tends, on the whole, to deteriorate, so that hoodlumism, lawlessness, destruction of property, and even more serious crimes, such as arson, larceny, assault, organized theft, and even murder, may ultimately develop. Under more favorable circumstances, however, the better social traits may prevail, so that, as the members of the gang grow older, intellectual interests may supplant the physical activity interests. It appears, furthermore, that boys and girls do not naturally organize together, and that the type of spontaneous organization formed by girls tends to differ from that formed by boys, being more frequently social, philanthropic and literary than athletic or predatory. Girls tend more strongly, also, to join societies organized for them by adults than to organize societies of their own.

Maxims for Organizing Societies. — Those who have had experience with controlling or organizing societies for young adolescents¹ are in general agreement upon the following principles: (1) Boys should be sought at about the age of 10 and their natural "gang instinct" supervised or controlled until it has died out or has been permanently directed toward worthy ends. (2) The basis and at least the initial stages of

¹ See, in addition to Sheldon and Forbush, Winifred Buck, *Boys' Self-Governing Clubs*. New York, 1903.

any society organized for boys must be sought in some phase of physical activity. Literary, ethical, scientific, or religious activities must be annexed, not too obtrusively, to the physical activity interest. Even in seriously purposed efforts to reach boys, the seriousness must not be too evident; the didactic element must not be too prominent. (3) The sexes are best organized separately; boys should be led by a manly man with a bit of athletic ability, considerable patience, and tact. (4) It is difficult successfully to maintain a society whose members are of different types, of different social stations, or perhaps from different neighborhoods. (5) Leaders of societies for boys and girls at this stage of maturity must not hope for great permanence in the organization; jealousies, disputes, and unexpected dissensions frequently disrupt them, however skillful the leader may be.

Variety of Adult-made Societies. — Nearly every adolescent, besides participating in spontaneous organizations, finds further outlet for his social tendencies by affiliating himself with some form of social organization directed or instituted by adults. The number and variety of these adult-made organizations is surprisingly great — instance such institutions as the summer camps, Boy Scouts, Boys' Brigades, debating societies, school literary and musical organizations, civic and patriotic societies, nature-study clubs, city-history clubs, social-settlement clubs, the Knights of King Arthur, the Animal Protective League, The Loyal Temperance Legion, the Band of Mercy, the Captains of Ten, the Epworth League, the Boys' Branch of the Y. M. C. A., the Junior Endeavor Society, the Brotherhood of St. Andrew, the Sunday School, and a host of others. Into their several merits and defects, from the standpoint of the needs and nature of the adolescent, this is not the place to enter. As Forbush has shown, no one of them is "the best." Few of them, unfortunately, make appeal to all, or even to many sides of adolescent nature, and in so far probably fail to make the strongest

possible appeal to their clientèle. Yet the idea of banding adolescents together for concerted action, even for a limited and somewhat selfish purpose, is undoubtedly worth while and is a first step toward attaining that wider unselfishness that seeks the best good of society at large.

School Organizations. — Within the school itself, the tendency toward organization has apparently greatly augmented during the past decade. We find in the ordinary high school various school and class organizations (class meetings, musical clubs, sketch clubs, art clubs, school periodicals, etc.), associations dealing with athletics and military drill, and secret fraternal organizations. These latter are sufficiently important to deserve separate consideration. As for the other associations and organizations we may summarize the conclusions reached by the comprehensive investigation of the Massachusetts Council of Education,¹ as follows:

1. "Class organizations, literary societies, musical organizations, art clubs, and school papers are helpful to the pupils and a benefit to the school, provided they are under the oversight of the school authorities.

2. "Class committees for purposes partly commercial (class pins, photographs, dances, etc.) are especially in need of the most exacting regulations.

3. "While more than half of the athletic associations which include and direct the varied athletic activities of the school are under the supervision, more or less complete, of the teachers of the schools, the right to control has been assumed rather than assured. Under this assumed control the participation in athletics is conditioned upon rank in scholarship.

4. "A large majority of the teachers reporting consider athletics a benefit to the schools. Sixty-five per cent believe that both scholarship and discipline are improved. But all

¹ Report on Organizations among High School Pupils. (T. C. Whitcomb, Chairman of Committee), *69th An. Rept. Brd. Educ. Mass.*, 1904-1905. Boston, January 1906. Public Doc. No. 2, pp. 178-198.

agree that this is only true when all such matters are under the control of the school authorities."

High School Secret Societies. — A problem of special interest to high school administrators is set by the development in recent years of the special form of social organization known as the secret society. The motives that have led to the appearance of the fraternity and sorority in the secondary school are primarily two in number: first, the influence of the general instinctive tendency toward the formation of social groups that we have been considering; secondly, the tendency to imitate college customs. While there is nothing intrinsically evil in either of these tendencies, their actual crystallization in the high school secret society has unquestionably been attended with evil consequences, so that at the present day, with a very few minor exceptions, school boards, superintendents, and high school principals and teachers are positively and strenuously opposed to them.

The arguments for and against the high school secret society may be summarized as follows: ¹

Alleged Merits. — (1) They satisfy the desire for social organization and promote fellowship among pupils. (2) They

¹ See for a more detailed outline, W. T. Foster, *Argumentation and Debating* (Boston, 1908), pp. 202-217.

The following are a few characteristic references on the topic: E. G. Godfrey, *High School Fraternities and Sororities*; the *Illiberal Education of the Young American Snob. Sat. Evening Post* (Phila.), January 7, 1905. W. Hard, *High School Fraternities*; *Farce, Tragedy, and Statesmanship. Everybody's Mag.*, 21: August, 1909, 173-183. P. B. Kohlsaas, *Secondary School Fraternities not a Factor in Determining Scholarship, Sch. Rev.*, 13: 1905, 272-274. W. B. Owen, *The Problem of the High School Fraternity. Sch. Rev.*, 14: 1906, 492-504. G. D. Pettee, *School Work and Secret Fraternities* (address in pamphlet form, given at University School, Cleveland, Ohio, January 12, 1905). Report of the Committee on Secret Fraternities, *Proc. N. E. A.*, 1905, 445-451. N. Melius, *Are Secret Societies a Danger to our High Schools? Rev. of Rev.*, 36: 1907, 338-341. S. R. Smith, *Report Committees on the Influence of Fraternities in Secondary Schools. Sch. Rev.*, 13: 1905, 1-10. The important decision of the Supreme Court of the State of Washington may be found in *Jour. of Educ.*, 64: December 6, 1906, 607; also in *Sch. Rev.*, 14: 1906, 739-745 and *Bull. No. 3 U. S. Bur. Educ.*, 1906, 136-141.

help to raise the standard of scholarship of their members. (3) They contain the best and most representative pupils. (4) They support all school activities and can accomplish more in this direction than a far greater number of unorganized individuals. (5) They furnish an opportunity for innocent, healthful good times. (6) Old members keep up a greater interest in their school after graduation. (7) Fraternity members are often assisted by meeting wearers of their pin in various places outside of their home town or city. (8) They reduce or eliminate undesirable rivalry between different high schools. (9) Some of them perform a small, but sincere work in the direction of philanthropy and charity. (10) Their exercises afford opportunity for training in literary, artistic, and other lines of activity. (11) They cannot be undemocratic and clannish, because they are not in operation during classroom exercises and other schoolroom activities.

Alleged Faults. — (1) They are essentially unnecessary. (2) They are fundamentally opposed in conception to the democratic spirit underlying the whole theory of public school education. (3) In selecting members, they often draw racial, social, religious, or professional lines and thus tend to promote snobbery and caste. (4) They interfere with school politics by combinations, trades, and other "underground" methods. (5) If their average scholarship is not inferior to that of non-fraternity pupils, it is at least lower than it would be if the societies were abolished. (6) Their social functions exact too much time and energy. (7) They "offer temptations to imitate the amusements and relaxations of adult life (card playing, smoking, dancing, late hours, etc.) while their members have not acquired the power of guiding their actions by mature judgment." (8) When rooms or houses are occupied, members often spend time in them which should be devoted to school work. (9) These club houses and rooms tend strongly to induce extravagance. (10) They tend, furthermore, equally strongly to moral de-

terioration: in some instances, vice has developed to alarming proportions. (11) The societies often interfere boldly with the administration of school discipline. (12) Initiation ceremonies, especially in the earlier days, have been degrading, if not positively dangerous to life and health.

Solutions of the Fraternity Problem. — There may be discerned three administrative attitudes toward the high school fraternities, viz: non-interference, regulation, and suppression. Those who officially ignore the secret societies do so either because they do not find them undesirable or because they are afraid to move against them.¹ Systems of regulation have commonly worked by (1) limiting the number of societies, (2) prescribing time, place, and character of meetings, (3) prohibiting membership without the written consent of parents and the indorsement of the principal, and (4) overseeing social functions and other activities of the organizations. Suppression may be accomplished by moral suasion under favorable conditions² but otherwise formal proceedings must be instituted. These usually take the form of regulations drawn up by the board of education withdrawing school privileges (participation in honors, membership in athletic teams, class offices, graduation honors, etc.) from all who continue in membership. In the few instances in which the fraternities have contested this regulation by resort to law, the decisions have favored the school authorities. Most important is the decision handed down by the Supreme Court of the State of Washington which fully upheld the position of the school board of Seattle, despite the contention of the contestants that the fraternal activities were private

¹ There is a real danger here. A writer in the *Journal of Education*, April 4, 1907, declares that "any high school principal is liable to take his livelihood in his hands when he attacks those in his school" and that experience has shown that "it is safe to antagonize them when a principal is sure of the loyal support of his faculty, of the unanimous and unhesitating support of his board of education and of the editorial and news departments of all the local press."

² See, for an instance, Pettee, *op. cit.*

affairs, outside of the jurisdiction of the school authorities. The final stage in the movement against this special form of social organization is seen in the enactment in several states (e.g. Kansas, Indiana, Minnesota, California, Michigan, Mississippi, Nebraska, Ohio, Oregon) of general legislation¹ absolutely prohibiting the establishment or continuance of secret societies in the secondary schools of the state.

Self-government Plans. — The transition to which attention has repeatedly been called from the control by others of childhood to the self-control of maturity, taken in conjunction with the manifest tendency to work together in teams, groups, committees, and other combinations, suggests very strongly that in the high school, if anywhere in the public schools, some form of pupil self-government would be logical and presumably successful. There have been developed in recent years a number of widely heralded plans for compassing this end.

The "School City." — A characteristic plan is that known as the "school city." In this, each pupil is a citizen; each room is called a ward, and practically all the officials of a regular city government — mayor, aldermen, board of health, police, city judge, and so on — are represented in the government, with such adaptations as are required by the special purposes of school government. The monthly elections follow prescribed forms, and one purpose of the plan is to afford concrete training in the operations of municipal government. In the extreme applications of the scheme, all school problems outside of classroom instruction, and especially, of course, all problems of discipline, are handled by this pupil-government, with a minimum of interference by the principal or teachers. These school cities have been organized in grammar and even in primary grades, though there seems, *a priori*, to be little sanction for the turning of the control of younger

¹ For the text of these laws, see *Rept. U. S. Comsr. Educ. for 1907*, Chap. XV, p. 437, and *City School Circular*, No. 8, April 15, 1912.

pupils into their own hands. As a matter of fact, the plan does not always work successfully in the high school. So far as the writer's observation extends, the school city is taken up with enthusiasm and enjoys a period of success, only, sooner or later, to become too arduous: the novelty of the enterprise wears off; jealousies and intrigue threaten the undertaking; over-harsh punishments are meted out; the training in cheap politics and "graft" becomes, perhaps, more evident than the training in citizenship; the teachers find their hands full in controlling the machinery, and finally the whole affair collapses in failure.

Simpler Self-government Plans. — A less intricate, and apparently more successful form of pupil self-government, in operation in the Polytechnic High School of Los Angeles and in certain high schools in Philadelphia and St. Louis,¹ provides that one boy and one girl be elected, every term, from each of the three upper classes, from a list of candidates whose scholarship is above a certain standard. Those elected form two committees, one for each sex, who have entire charge of the conduct of pupils, see that order is maintained in hall, study and recitation rooms, and even, to some extent, in the yards. They have authority, even to actual suspension, though only in consultation with teachers when dealing with extreme cases. The results of this form of self-government (which is, one may say, an oligarchy or "aristocracy," as compared with the "democracy" of the school city) are said to be excellent, provided that both parents and pupils give full adherence and that the committees are absolutely fair and are properly supported by the teachers. The idea seems difficult, but worth trying when conditions are favorable.²

¹ Bertha H. Smith, *Self-Government in Public Schools*. *Atl. Mo.*, 102: 1908, 675-678.

² For further literature on pupil self-government, see O. P. Cornman, *The School City: an Inquiry Concerning its Success and Value*. *Proc. of the New York Conference for Good City Government*, 1905, 280-289. B. Cronson, *Pupil Self-government*. New York, 1907. C. W. French, *School Government*. *Sch.*

Group Work in the Classroom. — If the social instincts of high school pupils may be utilized with some success in controlling discipline through various self-government plans, it is but natural to believe that the spirit of coöperation might be utilized within the classroom as well. In a few high schools where this type of group work has been tried, the results have, indeed, seemed very favorable. The scheme resembles in many ways the “seminary” type of instruction of the university. The various topics or phases of the subject studied are delegated to the several pupils of the class: each pupil reports upon the topics assigned to him, while the other members criticize, question, or discuss his report.

A characteristic instance of this type of group work has been reported from the Charlestown, Massachusetts, high school. Here the plan has been tried with classes in ancient history, United States history, and civil government. The recitation took on the form of a business meeting, with a president, vice president, and secretary. The lesson was conducted by the class, with the teacher as “executive officer” — a court of final appeal. The “report of the last meeting,” read by the secretary, served as a review. The carrying out of this work led to the formation of various secondary groups, such as a Drawing Club, a Camera Club, a Library Club, a Current-Events Club, a “Sidelights Club,” etc.¹

Rev., 6: 1898, 35-44. C. W. French, The School City. *Sch. Rev.*, 13: 1905, 33-41. G. H. Martin, Student Self-government. *Proc. Chicago Confer. for Good City Government*, 1904, 279-282. W. A. McAndrew, High School Self-government. *Sch. Rev.*, 5: 1907, 456-460. J. T. Ray, Pupil Self-government, *Jour. of Educ.*, October 25, 1906. T. R. Slicer, The School City as a Form of Student Government. *Proc. Chicago Confer. Good City Government*, 1904, 283-293. C. H. Thurber, High School Self-government. *Sch. Rev.*, 5: 1907, 32-35. P. A. Walker, Self-government in the High School. *Elem. Sch. Teacher*, 7: 1907, 451-457.

¹Lotta A. Clark, Group Work in the High School. *Elem. Sch. Teacher*, 7: 1907, 335-344. See also C. B. Shaw, Some Experiments in Group Work, *ibid.* 329-334. Colin A. Scott, *Social Education*, Boston, 1908, especially Chaps. VI and VII; and J. Dewey, *School and Society*, Chicago, 1900.

The advantages claimed for group work in the classroom are: (1) It utilizes the natural instinctive tendencies of the period. (2) It trains the pupils to work coöperatively. (3) It permits the individual pupil to concentrate his energy upon the particular thing that he most wants to do. (4) It stimulates constructive criticism by pupils of the work of their mates, and apparently appeals more powerfully than ordinary recitation work to the instincts of competition and desire for approbation. (5) It develops more enthusiasm for study, makes the school work more real and personal, less imposed from without.

Possible disadvantages would seem to be: (1) It may proceed slowly and take too much time. (2) It may fail to yield a proper perspective of the subject matter. (3) Pupils may fail to have a thorough understanding or permanent acquisition of those topics or phases of the subject matter not studied by themselves. In some subjects where drill in all details is essential this would seem to constitute a fatal obstacle to the plan. (4) Idle or incompetent pupils may shirk their assignments or present them so poorly that nothing would be gained for the class. On the whole, however, the idea of group work in the classroom deserves more attention than has yet been accorded it.

RELIGIOUS AND MORAL ASPECTS OF ADOLESCENCE. In the religious life of its members, the public secondary school can have, of course, no direct participation; nevertheless, this life is so often profoundly modified during adolescence and with such decided effect upon motives, ideals, and conduct that the teacher cannot afford to remain ignorant of the main features of this spiritual reconstruction.

Religious Conversion in Adolescence. — Adolescence is preëminently the time for religious conversion. Lancaster reports that, of 598 young people, 518 were ready to admit and describe to him a religious experience akin to conversion, which occurred, for the most part, between the ages 12 and

20. Statistics secured in various ways confirm the results of questionnaires and indicate that the years 15, 16, and 17 are the years of greatest religious impressionability.

The Explanation. — The explanation of these facts is not far to seek. The maturing of the sex instinct, with its strong attendant social instincts, means inevitably, as we have seen, a process of readjustment toward life, a transition from an individualistic to a social attitude, from egoism to altruism. If conversion, stripped of its theological implications, means a resolution to become unselfish, to array one's self on the side of right living, to sacrifice one's own desires for the welfare of others, then it is evident that what we might term a "secular conversion" is normal in adolescent development, and is really biologically determined. This converting (literally, *turning*) is by theology envisaged as a turning from sin unto holiness. Most adolescents, surrounded, as they are, by the strong and pervading influence of the church, come naturally to experience this instinctive readjustment of attitude as a religious readjustment. Many thinkers have felt, accordingly, that the richest service and most vital task of religion is to take charge of this transition from self-love to love of mankind, to make the transition complete, and to conserve and direct the activities of the adolescents who are experiencing it.

Tendencies toward Conventionalizing Conversion. — But there are certain dangers attending the formalizing by religious bodies of the experience of conversion. Particularly, to insist too much upon certain "patterns" of conversion is unwarranted in the light of what we know psychologically of the extreme individuality of all adolescent experience.¹ Even

¹ On this and other features of the psychology of religion, the student may consult: E. S. Ames, *The Psychology of Religious Experience*. Boston, 1910. G. A. Coe, *The Spiritual Life: Studies in the Psychology of Religion*. New York, 1900. W. James, *The Varieties of Religious Experience: a Study in Human Nature*. New York, 1902. A. H. Daniels, *The New Life: a Study of Regeneration*. *Amer. Jour. Psych.* 6: 1893, 61-106. G. S. Hall, *The Religious*

now some theologians teach that conversion is an instantaneous phenomenon, whereas the rule would appear to be otherwise; conversion is a gradual growth, not a sudden miraculous paroxysm. Again, there is a tendency to conventionalize and to accentuate the various stages of conversion — the “conviction of sin,” the “agonizing in prayer,” the joy of deliverance, the public “confession” are sufficiently illustrative. Some adolescents adopt these prescribed or approved forms of conversion, but others fail to experience them clearly and intensively, and may suffer exceedingly from what they regard as abnormality or unworthiness on their part. Finally, there is a tendency to encourage early conversion, despite the fact that the conversion of children is clearly theoretically unwarranted and nearly always practically unsatisfactory.

Periods of Intellectual Reconstruction. — In those whose minds are intellectually active the religious experiences of adolescence are rarely had without passage through one or more periods of critical reconstruction, usually with doubt and skepticism. The necessity of such reconstruction is fairly obvious. The child is credulous, imaginative, suggestible. His early instruction in matters religious and philosophical is of necessity simplified, metaphorical, and partial. Childish notions of God, heaven, immortality, sin, and the like can hardly fail to dissatisfy the keener intellect of the young man or woman. Mythical interpretations that appeased juvenile curiosity are too crude to harmonize with the larger knowledge of life of maturer years, and must go the way of the Santa Claus legends of childhood.¹ While in some natures this reconstruction of the cosmos is gradual, easy, and perhaps never completed, in others it is radical and

Training of Children. *Educational Problems*, Vol. I, Chap. IV; also *Adolescence*. J. H. Leuba, *Psychological Study of Religion; its Origin, Function and Future*. New York, 1912. J. B. Pratt. *The Psychology of Religious Belief*. New York, 1907. E. D. Starbuck, *The Psychology of Religion*. New York, 1899.

¹ Barnes, *Theological Life of a California Child*. *Ped. Sem.*, 2: 1893, 442-448.

stormy. Particularly in later adolescence may the uneasiness felt by glimmerings of inconsistencies in religious views extend to general doubt and uncertainty, until, finally, all religious belief may be repudiated, and the seeker after truth may swing over to agnosticism or indorse some system of humanistic ethics, morality without religion, or whatever code of belief best fits his private system of metaphysics. The continuance of secular instruction through high school, college, and university is almost certain to breed a period of conflict in the necessity that it throws upon every thoughtful student to readjust his earlier views in the light of his contact with science and philosophy and the general broadening of his mental horizon.

The question naturally arises whether reconstruction, especially the extremer forms of highly emotional, soul-racking internal struggle, is inevitable, or whether it might be, and should be, avoided by a better instruction in childhood. Some individuals, probably the minority, experience no serious interruption of the beliefs of childhood; the majority, however, begin, it appears, by doubting some phase of these beliefs, *e.g.* the efficacy of prayer, the miracles, the biblical account of creation, the immortality of the soul, the divinity of Christ, the goodness of God in permitting evil, etc. While some of these doubts are probably inevitable, others of them appear to be the product of mistaken early instruction, particularly of instruction that tends to exalt form over spirit, that presents the Bible as an inspired system of theology rather than an inspiring guide to life, that stresses dogma rather than the religious attitude. As Hall says: "Of all the outrages and mutilations practiced upon youth by well-meaning adults, insistence on such dogma upon pain of moral offense is perhaps the very most disastrous and anti-religious in its results, for it enlists the conscience of the individual, at an age when it is most vigorous and tender, against his own normal mental development."

Studies of Ideals. — Closely allied with the social and religious development of adolescence is a characteristic alteration of ideals. This feature has been well brought out in numerous studies,¹ which have dealt both with personal ideals and with ideals of future occupation. The usual method has been to ask pupils to state whom they would most like to resemble or what they would most like to do when grown up. Some investigators have also asked for reasons for the choice indicated; others have studied “negative ideals” — “What person would you most want not to be like, and why?”

The results of these investigations have been fairly consistent, and permit the following conclusions:

(1) *Ideals depend on Age.* — Despite some individual variations, there is a well-defined trend of development in ideals from childhood to maturity. Curves may be plotted, then, to show the rise and fall of this or that ideal. Younger children mention always persons in their own family or in their immediate circle of acquaintances and are impressed with objective values — wealth, beauty, social station, material possessions, etc. At puberty there occurs a marked widening of the range of ideals: historic characters, public personages, characters in fiction, and even imaginary persons replace the members of the family circle, while intellectual,

¹ Earl Barnes, *Children's Ideals. Ped. Sem.*, 7: 1900, 3-12. Earl Barnes, *Type Study on Ideals. Studies in Educ.*, 2: 1902, 36, 78, 115, 157, 198, 237, 277, 319, 359 (9 papers). Also, *Children's Attitude toward Future Occupation, ibid.*, 243. W. G. Chambers, *The Evolution of Ideals. Ped. Sem.*, 18: 1903, 101-143 (with 23 references). Estelle M. Darrah, *A Study of Children's Ideals. Pop. Sci. Mo.*, 53: 1898, 88-98. J. Friedrich, *Die Ideale der Kinder. Zeits. f. päd. Psych.*, 3: 1901, 38. H. H. Goddard, *Die Ideale der Kinder. Zeits. f. exp. Päd.* 5: 1907, Hft. 1-2. H. H. Goddard, *Negative Ideals, Studies in Educ.*, 2: 1902, 392-398. J. I. Jegi, *Children's Ambitions. Trans. Ill. Soc. for Child Study*, 3: 1898, 131-144. L. W. Kline, *A Study in Juvenile Ethics. Ped. Sem.*, 10: 1903, 239-266. C. H. Thurber, *What Children want to do when they are Men and Women. Trans. Ill. Soc. Child Study*, 2: 1897, 41-46. See also *Proc. N. E. A.*, 1896. J. P. Taylor, *Children's Hopes. An. Rept. State Supt. Pub. Instruc. N. Y.*, 1895-1896. Adelaide Wyckoff, *Children's Ideals. Ped. Sem.*, 8: 1901, 482-494.

æsthetic, moral, and religious values are substituted for the more material values of childhood. Moreover, ideals are evidently more vital and dynamic, more effective in motivating conduct in adolescence than in childhood.

(2) *Ideals depend on Sex.* — The range of ideals has always been found more restricted in girls than in boys. That is, girls tend more strongly to select ideals from their immediate environment and share less than do boys in the broadening of the scope of ideals at adolescence. Of special interest is the circumstance that whereas boys only rarely list women as their ideals, many girls, nearly 50 per cent in fact, find their ideal persons in the opposite sex — a condition of affairs that seems particularly unfortunate for young girls at this time when ideals of womanhood should normally be developing. Here is an opportunity for women teachers to come to the rescue of their sex. In the lists of favored occupations, teaching is most favored by girls, with nursing, dressmaking, and millinery frequently cited; boys are somewhat more apt to be animated by money-making motives.

(3) *Ideals depend on Home Life and Social Station.* — The children of the poor have relatively simple and “ low ” ideals, and look forward, according to Thurber, to a life of hard work, with little pleasure.

(4) *Ideals depend on Type of School Instruction.* — This assertion is an inference, however, from the fact that English and especially American children decidedly surpass German children in the range and variety of their ideals. It is possible that this outcome is due to racial or temperamental differences, but Meumann¹ believes that it points to fundamental differences in school instruction. German pedagogy lays too great stress on mere intellectual acquisition, too little on the cultivation of personality. If this be granted, it follows that it is highly important to give sys-

¹ E. Meumann, *Vorlesungen zur Einführung in d. exp. Pädag.*, 2d ed., I, 624-628.

tematic and definite attention in the school to the inculcation of ideals. In Germany, where formal instruction in religion and religious history is prominent, it appears that this part of the teaching has little effect upon ideals, whereas instruction in secular history, literature, and poetry is much more potent.¹

(5) *The Variety of Occupational Ideals* is surprisingly great. One might suppose that certain careers would be singled out as ideal by nearly all pupils. But in some 1200 answers to the question: "What would you most like to be in an imaginary new city?" — 114 different occupations were specified.

(6) *Their Alterations*. — Since ideals tend to change, and to change with special rapidity at adolescence, it is usually unfortunate if the process is prematurely arrested. Thus, a lad of 18, who aspires to be a lawyer and an orator, had at 16 an ambition to be "a pugilist and all-round sport." Had his teachers and parents not carried him past this earlier ideal, the results may well have been disastrous.²

(7) *Over-ambitious Ideals*. — In many adolescents ideals are curiously and excessively ambitious and impossible of realization. Through them runs, so often, a social and ethical vein which impels their possessor toward philanthropic and humanitarian projects. A school teacher of the writer's acquaintance summed up her adolescent ambitions in this

¹ That skillfully directed efforts may accomplish much in determining future careers of students is well illustrated in the success which has attended the "Baiting for College" schemes of some high-school principals, who have set up in their schools cabinets and display frames with photographs, catalogues, and other significant bits of information about various colleges and universities.

² To cite another typical case: A woman who is now a successful high school teacher of science wished for years in childhood that she were a boy in order to become an Episcopal rector (apparently largely attracted by his robe). In her grammar school days she planned to become a tight-rope walker and animal trainer in some large circus, and actually trained a pet dog and cat and tried to walk ropes in her back yard. During high school she wanted at graduation to open a large dressmaking shop, but she was induced to go to college, got interested in science, and finally in its teaching.

interesting and characteristic series: "To be the protector of unhappy women, to write the history of the world, to write novels as great as Victor Hugo's, to be an actress, to reform society, to uplift the degraded." Given such adolescent yearnings in minds of great natures, of true geniuses, they may, indeed, be realized, as the biographies of Joan of Arc, Savonarola, Lafayette, and George Eliot bear witness. Given such yearnings in mediocre and inferior, but persistent minds, and pathetic failure is the consequence. High school and college teachers will recognize readily enough this top-heavy combination of high ambition and poor ability.

MENTAL PATHOLOGY OF ADOLESCENCE. — Of the various disorders which may accompany the development of mental life during adolescence, attention can be called here only to the more prominent. Of actual mental deterioration, accompanied by brain disease, the most conspicuous and important disorder is the very puzzling and much-debated complex of symptoms known as precocious dementia, *dementia præcox*. This juvenile dementia, also sometimes known as hebephrenia, is a psychosis which tends to develop at the age of puberty. The beginning is insidious, with gradual weakening of attention, sluggish association of ideas, and marked indifference. The disorder proceeds by slow, but inevitable, stages to a general and profound intellectual enfeeblement.¹

Developmental Retardation. — *Dementia præcox* is a breaking down of mental life, a form of insanity — at least in the opinion of most writers. More common at adolescence, however, are certain forms of mental disorder which are due to functional disturbances or to lack of complete adaptation to the demands of mature life. The concept of arrested development as applied to the lowest grades of intelligence — the idiot, the imbecile, and the moron — is familiar to all.

¹ For further details, consult textbooks on insanity, e.g. J. R. de Fursac, *Manual of Psychiatry* (trans. by A. J. Rosanoff), New York, 1911, Chap. VIII.

What is less well known is the existence of analogous arrests, retardations, or deviations from normal mental development in the adolescent period. In fact, so intricate are these phenomena that this chapter of clinical psychology remains as yet largely unwritten. It is safe, however, to assert that the reconstruction of attitudes and interests that constitutes, as we have seen, the real psychology of adolescence may exhibit all degrees of incompleteness. The reconstruction is at bottom a reconstruction of feeling rather than of intellect, and in consequence the retardations and arrest of development attributable to the period make themselves evident more often in an inadequacy of adjustment to the widening demands of life or in an unhealthy attitude toward these demands than in insufficiency of intelligence. The defects are defects of will and of feeling. There is lack of normal social adaptation. Most of the chronic cases of neurasthenia and psychasthenia and even of the more serious mental disruptions of hysteria are cases of arrested or retarded mental development. Intellectual development may have been adequate, but action — complete, efficient, and socially adapted action — has not been attained. The clash of instinctive tendencies has not resolved into harmonious conduct. The feelings are similarly disjointed. These individuals, whose final attainment of mental maturity is thus frustrated, are impressionable, emotional, unstable; they may be timid or domineering, fawning or stubborn, self-effacing or self-conscious, egotistical, finical, often with tendencies not unlike those that usher in dementia præcox — seclusive, shy, dreamy, brooding over failure, given to sexual or other ruminating, self-deception, and superficial moralizing.¹ “The neuroses,” says Pierre Janet, the eminent French authority,

¹ See Adolph Meyer, What do Histories of Cases of Insanity teach us concerning Preventive Mental Hygiene during the Years of School Life? *Psych. Clinic*, 2: June 15, 1908, 89-101; also E. B. Huey, Retardation and the Mental Examination of Retarded Children. *Jour. of Psycho-Asthenics*, 15: 1910, 31-43.

“ appear almost always at the ages in which the organic and mental transformation is the most accentuated. They almost always begin at puberty.”¹

Higher Retardations as a School Problem. — The problem set for our school system by the existence of these higher grades of mental retardation is clear enough in theory, though as yet difficult in practice. There must be worked out some adequate system of diagnostic tests whereby, for a given individual, the fact of such retardation may be definitely established and its level definitely ascertained. Such a system of tests must be worked out by the research departments of applied psychology in universities, public school systems, and institutions for defectives. Along with these tests must be developed the clinical histories of numerous cases, so that we may in time know the early danger signals.

Whether by prescription of some regimen of mental hygiene, by more careful regulation of environmental conditions, or, perhaps, by recourse to the therapeutic measures of Freudian psychology, we may overcome these adolescent arrests of development, or whether, as the analogy of those earlier arrests of childhood would suggest, these later arrests are likewise due at bottom to hereditary, or at least to congenital, taint, it is perhaps too soon now to say. It ought at least to be possible to prescribe a mode of life and a sphere of activity in which these retarded minds may work happily and with all the efficiency they possess.

Adolescent Criminality. — Statistics show a sudden increase at puberty in the commission of crimes. From 10 to 13 years, lying, stealing, and vagabondage are the typical youthful offenses. Crimes against persons and those which combine violent passion with moral obtuseness make their appearance in later adolescence.

Causes. — Criminologists have advanced various explana-

¹ See his *Qu'est-ce qu'une névrose.* *Rev. scientifique*, January 30, 1909, 129-138.

tions for adolescent criminality, some of which are surely far-fetched and hasty generalizations; such, for instance, as the assertion that all pubescent girls have a natural propensity for pyromania. Other types of monomania are described in this extremist literature and assigned to various stages of mental development. The causes of criminality are both individual and social, *i.e.* both internal and external. It is certainly possible for the social factors to work alone; contact with new industrial and financial problems, weakening of parental control and other environmental circumstances may cause an adolescent whose mental equipment is entirely normal to commit crime. However, we may add to this that normality in adolescence does include a transition through a yeasty stage of physical and mental upheaval which is sufficient to account for a great many minor trespasses. Lawlessness, impulsive misconduct, the sowing of the proverbial "wild oats," and even passionate outbreaks may appear as transient phases of the mental and moral adjustment of the period, so that moral delinquency in adolescence does not necessarily imply confirmed criminality.¹

On the other hand, there are cases of criminality which can be traced to individual factors which are really abnormal. A youth who, from adolescent arrest, has failed to make adequate social adaptation, has doubtless within him a predisposition toward non-social acts which needs only the stimulus

¹ If the "gentle reader" has himself never strayed from the path of legal rectitude, let him read Swift's account (*Some Criminal Tendencies of Boyhood; a Study in Adolescence, Ped. Sem.*, 8: 1901, 65-91), wherein several dozen college professors, normal school teachers, lawyers, ministers, dentists, merchants, and other respectable citizens confess to adventures, truancy, fighting, robbing orchards, stealing watermelons, old iron, and money, breaking car windows, lying and other offenses of their juvenile and adolescent days. Swift goes so far as to conclude, I think rather rashly, that "there can hardly be any doubt that there is a time in the life of every normal boy when primitive impulses, the reverberation of savage life, carry him on, with almost resistless fury, toward a life of crime. When to these native impulses there is joined an environment favorable to crime, there can be little hope for successful resistance."

of circumstances to show itself in criminality. Moreover, it is not unreasonable to believe that the increased complexity of modern civilization makes social adaptation more difficult, so that this, taken in conjunction with a less strict family life, less strenuous emphasis upon moral training, earlier personal liberty, the greater predominance of urban life, the prominence given to crime in the newspaper, and the apparent weakening of the religious sentiment, may account for what is generally acknowledged to be an increasing precocity in crime and an increasing proportion of youthful criminals.

Remedies. — The remedies must doubtless be sufficiently varied to counteract these varied factors — partly social, industrial, and economic, partly individual, moral, and educational. Particularly in the case of adolescent criminality should the attempt be made to reform the offender himself.¹

That systematic and persistent efforts at moral and religious training do have a direct and measurable effect in reducing criminal tendencies seems to have been established by an important investigation, as yet unpublished, carried on at the University of Illinois under the direction of Dr. W. C. Bagley, to whom I am indebted for an account of the conclusions. From this study it appears that those religious bodies that lay most stress on the moral training of their members are represented by the fewest number, relatively, of convictions for crime.

Of special interest in this connection are the ten principles of the "*Credo*" of Mr. George, whose long personal experience with the boys and girls of criminal tendencies in the Junior Republic entitles him to speak with authority. These principles may be paraphrased from Mr. George's words² as follows: (1) Normal, healthy boys are pretty much alike,

¹ For a good discussion of this problem, consult G. L. Duprat, *La Criminalité dans l'Adolescence*. Paris, 1909.

² W. R. George, *The Junior Republic: its History and Ideals*. New York, 1910. See especially the last chapter.

the world over, regardless of class or social condition. (2) Hero worship, dare-deviltry, love of praise, curiosity, comradeship, and lawlessness are fundamental components of boy nature. (3) Superabundant physical energy is bound to find an outlet somehow. (4) These mental and physical traits, coupled with the care-free condition of youth, make more or less inevitable a "vigorous crop of wild oats during the 'teens.'" (5) This "transit of fool's hill" is terminated, for the average boy, only when he comes to feel responsibility for himself or for others, when, in other words, he becomes "a World's Worker." (6) There are two sorts of these workers, those who do right for right's sake, and those who do right for policy's sake. (7) Opposed to the workers are the lawless, who are youths still in their teens, or maturer individuals who have not yet felt the saving shock of responsibility. (8) The workers come to forget their own wild oats and are too apt to have no sympathy for misdemeanors of the lawless; so they demand a *System* for their reformation. (9) The *System*, which in the concrete is known as Prison, Reformatory, etc., is unnatural and un-American, and it fails of its purpose because it neglects the individual for whom it was devised. (10) The only remedy for this failure is the organization of such a community or village as the Junior Republic, wherein is incorporated the opportunity to learn the essential lesson of responsibility.

INTELLECTUAL GROWTH IN ADOLESCENCE. — Our study of the mental traits of adolescence has been confined thus far very largely to the sphere of instinct and feeling. The intellectual development of the period and its relations to high school teaching now merit brief consideration. Many careful observers believe that there is a period of a year or so just at puberty when children, especially girls, show a surprising and irritating stupidity. If this observation be correct, it would seem to be connected in some way with the physical alterations of the period, as if brain growth stagnated

while the body was undergoing transformation for the function of maturer years.

In the main, however, adolescence is characterized by the attainment of the final stages of efficiency in different mental capacities; memory span, for example, reaches its maximum at 16 or 17. Again, the development during this period of numerous collateral neurones in the central nervous system agrees with the evident increase of capacity for complexly organized association systems, so that the adolescent can deal with more elaborate and difficult concepts than the child. As his critical ability and capacity for independent thinking increases, there is a modicum of truth in the common notion that "reason" is an adolescent, rather than a juvenile "faculty."

To attempt to organize high school work upon the basis of a psychology of adolescence alone seems, however, to be an impossible undertaking, because the selection of subject matter and of methods and pace of instruction is largely governed by other factors, not the least of which is the dominating influence of college entrance requirements and the general acceptance by secondary school authorities of the idea that all students should follow the same methods and pace within any given subject as are followed by other pupils who are taking the subject in preparation for college. We may state here, however, a number of principles which seem to be justified by psychological and pedagogical research.

The Problem of Formal Discipline. — In the discussion of the organization of high school work (p. 222) it has been urged that no subject deserves to be retained in the curriculum whose sole or whose primary sanction is the mental discipline it affords. It remains to set forth more clearly the grounds for this principle.

In the elementary school the issue of formal discipline is scarcely raised at all: some subjects are studied for their direct value as sources of information; other subjects, like

reading and writing, though sometimes referred to as "formal" studies, are pursued for their intrinsic usefulness and not for their formal discipline in the sense of indirect mental training. In the high school, on the contrary, nearly all subjects in the curriculum are espoused or defended not only for their direct, but also for their indirect, formal value; indeed, the disciplinary worth may be put foremost in the argument for their inclusion in the curriculum. Thus, the study of high school mathematics, though urged in some degree for its intrinsic value as information, *e.g.* usefulness in professional, industrial, and like activities, is often still more emphatically urged as a means for training concentration of attention, accuracy, and power to reason. Similarly, whole courses of study have been prescribed with the idea that in that way alone could a predetermined type of mental training be secured (all pupils should take botany for training their powers of observation, etc.).

It is profitable, then, to examine with care the arguments advanced for and against this doctrine. The issue necessitates, first of all, the drawing of a distinction between content and form, between information and training in the narrower sense. A knowledge of Latin undoubtedly facilitates the learning of French, but in what way? In part, obviously, because French is a Romance tongue and contains many features that closely resemble analogous features in the Latin. The French vocabulary comprises numerous terms whose roots are derived from the Latin vocabulary. In so far as this is the source of the assistance given by the study of Latin to the study of French, evidently what is carried over from the one study to the other is information, not formal training. We may speak in this case of a "spread" or "transfer" of efficiency or ability from one subject to the other, but not in the sense of formal discipline.

Assume, however, that the study of Latin facilitates the learning of German or architectural designing or intensive

farming. In these cases there can be relatively little direct carrying over of information as such. The profit for these several lines of activity must be in another sphere, and it may, in theory, be of two kinds, specific or general. The mental training developed by Latin may include certain methods or ways of going to work in the handling of linguistic material, in which case there has been gained a *specific discipline* that will be serviceable in the learning of the German or of any other language. Or, the mental training in Latin may include certain methods or ways of undertaking any sort of mental work, *e.g.* training in concentration of attention, in assiduity, in patience, in analyzing complex situations, in synthesizing isolated items into a meaningful and ordered whole. These latter capacities are evidently instances of *general discipline*, since they are of an order that can function in various and varied situations, whether linguistic or non-linguistic.

The work of high school pupils in a given field may, therefore, result, in theory, (a) in the acquisition of information which will be of direct service in related fields, (b) in specific mental training that will be of service in fields of a like kind, or (c) in general mental training which will be of service in many and widely divergent fields. It is with these last two types of spread or transfer of the effects of special drill that we are concerned in the problem of formal discipline.

The Older View. — The older view of formal discipline assumed without much question the existence of a general spread of mental training. This view still remains the “common-sense” view of the “man-in-the-street.” It had its support largely in the commonly accepted “faculty” psychology, according to which the mind is composed of a number of faculties — imagination, memory, reasoning, observation, and the like — and according to which the carrying on of any specific bit of imagining, remembering, reasoning, or observing entailed the exercise as a whole of the faculty con-

cerned. Any bit of reasoning, then, would strengthen the faculty of reasoning. A second common argument for formal discipline rests on the analogy of physical training and exercise. A man, who by appropriate exercises with a weight machine in the gymnasium adds a half inch to the girth of his biceps, thereby stores up added power which he can turn to use later in chopping down a tree or rowing a boat. A third argument for this view calls attention to the relation of general ability in the population at large to educational training. For example, college graduates are shown by statistics to be greatly superior to non-college graduates in making a success in life; hence, their success is due to the superior training.

Arguments against It. — These three chief lines of argument are refuted by some such arguments as the following. Modern psychology denies the existence of the old-fashioned mental faculties and substitutes for them the notion of numerous very specialized mental functions. There is not one faculty of memory, but visual memory, auditory memory, memory for faces, memory for poetry, etc.¹ The argument from physical training, like all arguments from analogy, is weak. The biceps is, after all, the same biceps, whether contracted for rowing or wood chopping, whereas mind is not so simple as muscle, as has just been pointed out. Finally, the argument based upon the generally superior performance of persons subjected to prolonged mental training may be met by the assertion that this inference is a *post hoc propter hoc* fallacy, that in truth those who pursue the higher education are a group selected by their very inclination and ability to master complex issues and employ their minds with larger and more difficult problems, that, moreover, they owe their success in part to the prestige and distinction attendant upon their

¹ See, in illustration, G. M. Whipple, The Effect of Practice upon the Range of Visual Attention and of Visual Apprehension. *Jour. of Educ. Psych.*, 1: 1910, 249-262, especially pp. 258-259.

college career, and in yet greater part to the acquisition of highly specialized information along certain professional lines. It might even be argued, if one wished to force the retort, that college-trained men succeed in spite of their training. Or, again, it can be urged that even those who have mastered extensive cultural training often exhibit only a limited or one-sided efficiency: they may be good in music and poor in linguistics, skilled in oratory and poor in mathematics, etc.

Experimental Studies of Transfer. — So much for arguments. The issue of formal discipline, however, has been subjected to elaborate experimental study during the past decade. It is the outcome of these experiments,¹ in fact, that has influenced many to entertain a general distrust of the doctrine, if not to deny flatly the existence of any transfer of mental training. Some of these experiments have concerned what is known as bilateral transfer, *i.e.* the effect of special exercise of a sense organ or of a particular movement on one side of the body upon the capacity of a corresponding organ or movement upon the other side. But the greater part of the experiments have concerned the transference of practice-effects from one form of mental activity to another. In the typical experiment a preliminary trial is made to determine the ability of a group of subjects in a given direction, *e.g.* learning numbers, letters, Italian words, etc. This group is then drilled at length in some other activity, *e.g.* learning nonsense syllables, and is finally given a second trial with the original, or test material. Other persons are given the two tests with the original material, but are not given the intermediate drill. If the drilled individuals show much greater final improvement in the tested activity than do the "control" or undrilled individuals, then it is argued that the drill work did develop

¹ See for a summary of the experimental work, article on formal discipline, *Cyclop. of Educ.*, Vol. 2, p. 642; S. S. Colvin, Some Facts in Partial Justification of the So-called Dogma of Formal Discipline, *Univ. of Illinois Bulletin*, Vol. 7, No. 26, 2d revised edition, February, 1910; W. H. Heck, *Mental Discipline and Educational Values*, 2d ed., 1911, especially Chap. 3.

some kind of capacity that facilitated the test work; that there was, in other words, some kind of transfer of capacity.

The results of the earlier experiments, e.g. the well-known work of James¹ and the Columbia experiments,² have been generally interpreted as conclusive evidence against formal mental training. But these results have been subjected to much criticism since their publication, while the trend of later experimental work has been much less decidedly against sweeping denial of transfer-effects. On the contrary, it would be safer to assert that in practically all carefully planned experiments, notably in the extensive experiments of Ebert and Meumann upon memorizing, an amount of transfer is indicated sufficient to receive serious consideration. It is true that the opponents of formal discipline have criticized with some severity much of the experimental work that has seemed favorable to transfer. It would seem safe, however, to state that the net result of the experimental work has been to discredit any extreme view. Formal discipline cannot be flatly denied, neither can it be regarded as invariably and necessarily existent. In some ways, too, the experimental work, because it has been for the most part restricted to laboratory tests with adults, has left untouched the essential educational problem: precisely of what nature and of what magnitude is the transfer of mental training under actual conditions of school instruction? It cannot be said that psychology has at present any satisfactory answer to this problem. It remains a matter for future investigation, particularly so when we inquire concerning general rather than specific discipline.

To quote from Colvin (p. 17): "Whether the results are due to transfer of identical elements (Thorndike); to improve-

¹ *Psychology*, Vol. 1, p. 667.

² E. L. Thorndike and R. S. Woodworth, The Influence of Improvement in One Mental Function upon the Efficiency of Other Functions. *Psych. Review*, 8:1901, 247-261, 348-395, 553-564.

ment of habitual methods of recording facts (James); to training the attention and will-power (Scripture and Davis); to divesting the essential process of the unessential factors, greater habituation and more economical adaptation of attention (Coover and Angell); to the effective use of mental imagery and properly controlled attention (Franker); to the development of ideals (Bagley and Ruediger); to general improvement in technique of learning, attention and will-power, but chiefly to a sympathetic interaction of allied memory functions (Ebert and Meumann), or to some other factors as yet not analyzed out, may still be a matter of investigation and debate. My own personal opinion is that practically all of these are more or less important elements in the transfer."

Conclusions based upon Adults may not apply to Children. — There remain to be mentioned two or three features of this problem which, in the writer's judgment, are apt to be lost sight of in the discussion. One is that conclusions reached with adults, especially with adults already trained in mental activity, may not apply to untrained adults and still less to children, whose mental habits are not yet matured. Experimental work performed upon school children at Ithaca, and soon to be published,¹ has shown an apparent gain in general mental efficiency on the part of school children subjected to special formal drill in visual apprehension that is quite in contrast to the absence of such general effects on the part of adults tested in the laboratory.

Negative Transfer. — Another feature which has been clearly brought out in experiments is that the mental "set" or "attitude" developed by a particular form of drill work may hinder rather than facilitate the performance of certain other mental activities. There may result, for example, what is known as "interference" of associations, or "negative transfer." Thus, drill in precise expressive reading may conceivably be carried far enough to operate against the ac-

¹ K. M. Dallenbach, *Jour. of Educ. Psych.* June and September, 1914.

quisition of high speed "skimming" in reading, so desirable for many phases of adult work. Again, if high school geometry does train the pupil to reason correctly, it is possible that it unfits him to carry on reasoning about the complex matters of daily life in which contingency, qualification, and necessity of appraisal of conditions replace the cut-and-dried, right-or-wrong type of reasoning of the geometrical theorem.

The Teacher as a Factor. — Finally, another feature, too often lost sight of, is that the disciplinary values that do exist actually inhere less in the subject matter itself than in the method by which it is presented, so that the skill and insight of the teacher are perhaps more important than the subject matter taught. High school mathematics, for instance, may be so taught as to emphasize memoriter activities, or processes of proof, or yet other phases, such as the "feel" for geometrical relations. Similarly, a desirable mental attitude of cautiousness in drawing conclusions from scanty data might be developed by one teacher in biology and by another in the study of Latin. Let the reader attempt to appraise his own possessions of this sort, and then let him try to decide just when and in what subject he secured the drill that made him diligent, neat, punctual, keenly observant, rational in argumentation, capable of intellectual concentration, quick to grasp the merits of an issue, prone to see both sides of every question, assiduous in following all problems to their conclusion, fertile in imagination, resourceful in an emergency, and so on to the end of his virtues. He will find it difficult or impossible, so automatic and ingrained are these attitudes and tendencies in adults, to analyze them into clearly conscious mental habits or ideals, or to say with any certainty when or how they were acquired in the course of his school training, or whether, indeed, they may not have developed as simple functions of maturity. Yet these are the things that are set forth as the definite and positive results of studying this or that high school subject.

In conclusion, then, the best rule that can be laid down is: no subject should be introduced into the curriculum for the sake of its formal training alone, but every subject should be so taught as to secure from it all possible drill in correct methods of thinking and worthy ideals of mental action.¹

Alleged Inadequacies of High School Science. — The choice of material and type of presentation in high-school science does not accord well with the natural inclinations and interests of adolescents. There is over-insistence upon technical nomenclature. There is over-insistence upon quantitative and mathematical treatment, especially in physics and chemistry. In biology, morphology, analysis, and the study of structure is stressed too much to the neglect of the dynamic and the functional. Such, at least, are the conclusions of Stanley Hall,² who believes that these tendencies devitalize and dehumanize science, and who would substitute a genetic order of approach with four main stages: 1st, acquaintance with simple, primitive, mythical men and poetic interpretations of nature; 2d, popular science, like the material published in the *Scientific American* or *Popular Mechanics* — box-kites, photography, moving pictures, wireless telegraphy, etc.; 3d, applied science and the utilitarian aspects seen in various branches of technology, economic geology and botany, mechanical and electrical engineering; 4th, pure science, or science for science's sake, to be pursued last of all and to be relegated for the most part to the college and university. Recent tendencies in high school science have in some measure incorporated these recommendations, though it has seemed impossible to adopt them fully, even were it agreed that instruction should always follow that order of presentation

¹ For further discussion of the subject, consult, in addition to the references cited, the symposium on formal discipline by Angell, Pillsbury, and Judd, *Educ. Rev.*, June, 1908; the second symposium by Delabarre, Henderson, and Horne, *Education*, May, 1909; W. C. Bagley, *The Educative Process*, Chap. 13.

² Adolescent Feelings toward Nature and a New Education in Science, *Adolescence*, II, Chap. 12.

suggested by genetic psychology. Does our science teaching, one may ask, really "arrest and mutilate the soul of adolescence by prematurely forcing it into the mental mold of grown-ups"?

Linguistic Interests. — The common practice of beginning a foreign language in the first high school or last grammar school year receives endorsement from studies which indicate at puberty a new interest in linguistic expression, a desire to augment one's vocabulary.¹ Since this interest is an interest in the use of words in actual expression, it would seem that a spoken language, like French or German, would be a more natural thing to study at this time than a written language like Latin. On the other hand, the question may fairly be raised as to why any one of these languages should be taken up by secondary school students, at least by those who are not to continue them in college. While this is not the place to discuss educational values of the high school branches, it may be pointed out that few high school graduates gain much acquaintance through their linguistic work with the literature, history, or civilization represented by the foreign tongue, that practically none of them cares to, or can, either read or speak Latin, French, or German after graduation, that the increase in familiarity with English etymology and English grammar gained through foreign language study is not noteworthy in comparison with the time that is devoted to it, and that the improvement of English style and diction by exercises of translation is secured only when very competent teachers make persistent efforts in that direction.

Literary Interests. — Most adolescents have at some time during their secondary school days what they term a "craze for reading." Since sensational and trashy books are often

¹ It has even been argued that the use of slang by girls in early adolescence is a phase of this desire; see Lillie Williams, *Interest of Children in Words*, *Ped. Sem.*, 9: 1902, 274.

read for want of a proper notion of what is worth while, parents and teachers should utilize this opportunity to cultivate literary taste and protect boys and girls from what are really vicious forms of the "reading habit." Lancaster took a census of the type of reading preferred by adolescents and found the preferences to be in the order: novels, 812 votes, poetry 797 (which is perhaps unexpectedly and suggestively high), essays 67, history 37, travel 30.

Art Interests. — As has already been pointed out (p. 262), interest in art — music, drama, architecture, painting, etc. — is decidedly augmented during adolescence. In some, probably in most, the interest is but transient; but in the truly gifted, notable progress is made during adolescence both intellectually, in the understanding of art and development of taste, and emotionally, in a richer feeling for the esthetic. The school cannot afford to neglect this phase of cultural training. Even in intentionally utilitarian types of secondary school, *e.g.* high schools of agriculture, those who plan the curriculum should remember that bread-and-butter winning is but a part of life. Psychologists have shown how the play of children is normally replaced in later years by some form of artistic activity, be it music, painting, some form of decorative or plastic art, or other recreative handicraft in which the esthetic instinct may find expression.

COEDUCATION. — A final word may be said on the bearing of the physical and mental features of adolescent development upon the problem of coeducation. It should be made clear at the outset that coeducation does not necessarily mean co-instruction. One may be convinced from sociological and economic considerations that youths and maidens should study the same subjects, but conclude from physiological and psychological reasons that they should study them in separate classes or in separate schools. In cities where more than one high school is imperative there has often been found an advantage in making the separation by sex rather than on

geographical or other bases. In other schools it has been found worth while to adopt a system of partial segregation. A typical illustration is afforded by the practice at the Englewood High School,¹ where boys and girls have recited in separate classes and the work has been adapted to the interests and needs of the two sexes. It is stated that four years' trial has resulted in a striking increase in attendance, and in a marked improvement of scholarship, especially of the boys. Moreover, a majority of the pupils — 60 to 96 per cent of the girls and 87 to 100 per cent of the boys in various classes — have declared themselves in favor of the plan.

The chief arguments for a different curriculum for the two sexes are sociological and relate to what is felt to be the fundamental difference between the prospective future lines of activity of boys and of girls. Particularly, it is urged that the majority of girls are destined to careers in which the home will be the center of interest and that their high school training should, accordingly, be directed mainly toward this end. Coeducation renders it impossible properly to differentiate the school work in this way. Counter arguments assert that modern conditions indicate, on the contrary, the necessity for identical training of the sexes, that thousands of girls enter upon occupations for which they need the same training as boys, and that, even if the majority are destined ultimately to domestic activities, they need, as wives and mothers, the same cultural training and the same general background of information as their husbands and children.

Into the merits of these several arguments this is not the place to go.² If we turn to the arguments from psychology and physiology, they are found to reduce in the main to two: first, that men and women are physically and mentally funda-

¹ J. E. Armstrong, *The Advantages of Limited Sex Segregation in the High School*. *Sch. Rev.*, 18: 1910, 339-350.

² Consult article Coeducation in *Cyclopedia of Education*.

mentally different¹ — so different that they need different mental and physical training, so different that no amount of identical training can equate them.² Second, that adolescent girls are handicapped by their physical constitution, so that it is a crime to attempt to put them through the course of training that is suited to adolescent boys.³ It is no longer contended that girls are incapable of doing as much or as good work as boys — experience has proved the contrary — rather that they compete with boys at the expense of their health.

TOPICS FOR FURTHER STUDY

1. What are the chief problems and the chief factors in the development of the will, especially in adolescence?
2. What is the relation of vocation and the vocational motive to character?
3. Does high school training lead away from manual work?
4. What is the relation of the esthetic to the moral?
5. What are the moral effects of various studies?
6. What educative effect does student self-government or the "honor system" have?
7. What are the educative and the moral values and problems of social life — clubs, societies, fraternities, dancing, etc.?

¹ For an inventory of these differences, see G. T. W. Patrick, *The Psychology of Woman*. *Pop. Sci. Mo.*, 47: 1895, 209.

² This contention seems somewhat at variance with another frequently heard argument against coeducation, viz.: that it does not permit the two sexes to develop adequately those qualities which are natural to them; that it tends to make girls too masculine and to effeminate boys. On the other hand it is urged in reply that coeducation exerts a desirable disillusionizing influence and tends to make the relations between the sexes more wholesome, that there is really no more reason for separating the sexes in the classroom than in the drawing-room.

³ As the phrase goes, we "spoil a good mother to make a poor grammarian." This, which might be termed the medical argument, is found in a host of articles. For references and further discussion see Hall, *Adolescence*, also his *Youth*. One of the earliest and most discussed books on this theme is E. H. Clarke's *Sex in Education, or a Fair Chance for Girls* (Boston, 1873). A reply to Clarke will be found in Geo. F. and Anna M. Comfort, *Woman's Education and Woman's Health*. 1874.

8. What are the advantages and disadvantages of coeducation in the high schools? Of partial segregation? Of separate schools?
9. What is the relation of sex hygiene to general education? How should the problem of instruction in sex hygiene be handled?
10. What progress has been made in the solution of this problem?
11. What is the relation to character formation of athletics; inter-scholastic contests; physical training?
12. What loss is there of individuality and initiative, and hence moral intelligence, through the pressure of custom and fashions?
13. What is the moral effect in high school of college ideals and fashions?
14. What relation does the size of a school have to the attainment of moral results?
15. What are the sources of moral influence on the part of the teacher?
16. Make a study of great teachers of youth: Vittorino, Loyola, Arnold of Rugby, Thring of Uppingham; Mark Hopkins; etc.
17. What is the value and what are the best forms of religious exercises and instruction?
18. What is the ethical value of the study of current social and economic movements?

REFERENCES

- BURK, F. S. Growth of Children in Height and Weight. *Am. Jour. Psych.*, 1898, pp. 253-326.
- BERRY, FRANCES MAY D. On the Physical Examination of London School Children and the Prevalence of Albuminuria. I. *Internationale Kongress für Schulhygiene*, Nürnberg, April, 1904, Band III, pp. 421-425.
- BURNHAM, WILLIAM H. The Study of Adolescence. *Ped. Sem.* 1891, Vol. I, No. 2, pp. 174-195.
- CLOUSTON, THOMAS S. *Hygiene of Mind*. London, 1906. 284 pp. *Neuroses of Development*; being the Morison lectures for 1890. London, 1891, 138 pp.
- CRAMPTON, C. WARD. Anatomical or Physiological Age *versus* Chronological Age. *Ped. Sem.* June, 1908. Vol. XV, pp. 230-237.
- HALL, G. STANLEY. *Adolescence*. 2 vols. New York, 1907.
- Youth*. New York, 1906. A résumé of the pedagogical aspects of adolescence.
- KING, IRVING. *The High School Age*. 233 pp. Indianapolis, 1914.
- LANCASTER. Psychology and Pedagogy of Adolescence. *Ped. Sem.*, 1897, pp. 61-128.

- LEMAITRE. *La Vie Mentale de l'Adolescent, et ses Anomalies*. Paris, 1910.
- MARRO, A. *La Pubertà*. 507 pp. Bocca, Torino, 1897. French translation, *La Puberté*. Paris, 1902. This deals chiefly with the physiological side of the subject.
- MEYER, ADOLF. What do Histories of Cases of Insanity Teach Us Concerning Preventive Mental Hygiene during the Years of School Life? *Psych., Clinic.* June 15, 1908. Vol. II, No. 4, pp. 89-101.
- MOLL, A. *Sexual Life of the Child*. 339 pp. New York, 1911.
- SCOTT, COLIN. *Social Education*. Boston, 1908.
- SLAUGHTER, J. W. *The Adolescent*. 111 pp. London, 1911.
- STARBUCK, E. H. *Psychology of Religion*, especially the sections dealing with conversion. New York, 1901.
- SWIFT, E. J. *Mind in the Making*, 329 pp. New York, 1908.
- TYLER, J. M. *The Laws of Growth and Development*. New York, 1906.
- For physiological and abnormal phases of the subject, the reader should also refer to the works of Havelock Ellis and Freud.

CHAPTER VIII

MORAL AND RELIGIOUS EDUCATION

HOW THE WILL GROWS

WILL DEVELOPMENT THROUGH WILL ACTION.

— The character of the individual is little changed by what he merely undergoes: Herbart long ago called attention to the remarkable fact that physical agony, even though intense and long continued, may leave the character essentially unchanged; men rise from the most serious bodily accidents and illnesses the same in opinions, manners, and morals. It is what the individual himself resolves and does that forms new habits and attitudes and so essentially modifies character. “Those things which proceed out of the mouth come forth from the heart, and they defile a man”; no less do such things, when good, ennoble a man. In both cases the things that proceed from the heart — *i.e.* the will — leave their mark on character. Mere external compliance is futile in producing habits, principles, or ideals. The literature on moral education is always echoing the cry of the German teacher of religion, when his most recalcitrant pupil passes the most brilliant examination. “Why, he know it all!” the examiner cries. “Yes, but he believes none of it!” retorts the discomfited but unconvinced teacher.

In one way it is a mere truism to say that will power and righteousness grow by exercise of will, and in no other way. There would be no excuse for dwelling upon the principle if it were not that it is sweepingly ignored in practice; both the principle itself, and the prevailing disregard of it in our educational practice are admirably expressed by Professor Dewey: “No one seriously questions that, with an adult, power and

control are obtained through realization of personal ends and problems, through personal selection of means and materials which are relevant, and through personal adaptation and application of what is thus selected, together with whatever of experimentation and of testing is involved in this effort. Practically every one of these three conditions of increase in power for the adult is denied for the child. For him problems and aims are determined by another mind. For him the material that is relevant or irrelevant is selected in advance by another mind." . . .¹

We may well be apprehensive of an education that occupies the adolescent youth with doing what some one tells him to do, and confers its highest rewards and commendations without regard to independence or originality of either intellect or will; and, moreover, compels him to employ his school hours with so-called studies (far indeed from the true sense of the old Latin word) the very meaning and use of which he does not comprehend and often profoundly doubts. Such education can form only a will that is dependent, unstable, void of self-reliance and initiative: not necessarily lacking in mere force or violence, but devoid of the sole supreme mark of a mature or maturing will, a self-existing and self-sustaining purpose.

Hence it is that the boy's actual will training is almost certain to take place out of school, and the influences of culture and higher thought which the school more than any other agency should communicate, fail to penetrate deeper than the most superficial layers of memory, and fade into oblivion almost before the expiration of the term in which they are studied: and volition, with all its domination over life, is determined by business, politics, pleasure, — or on the other hand by the stimulus of some upward social movement in the larger world.

¹ *Psychology and Social Practice*, p. 128. See also College Students' Comments on their own High School Training, *School Review*, December, 1912.

INTELLECTUAL ASPECT. — Not only does will grow only by exercise of will, but intellect also develops most effectively under the stimulus of the learner's own self-active purpose and volition. Every teacher knows how knowledge and intellectual mastery leap forward when the pupil is eager to learn. Attention is the absolute *sine qua non* of new associations and so of knowledge and mental power,¹ and attention is also in its deepest forms indissolubly linked with voluntary action or will.² So far, then, from true moral training in any way detracting from intellectual achievement, the exact opposite is the case; if we can enlist the pupil's will in such manner as to secure true moral development, we shall also increase and wonderfully enhance the progress of the intellectual powers. "Since problems of conduct are the deepest and most common of all the problems of life," says Professor Dewey, "the ways in which they are met have an influence that radiates into every other mental attitude, even those remote from any direct or conscious moral consideration. Indeed, the deepest plane of the mental attitude of every one is fixed by the way in which the problems of behavior are treated."³

Dr. Kerschensteiner, out of a rich experience in the practical problems of public education, declares: "Any training of the intellect deserves attention only so far as it rests on the character — in a manner it proceeds from the character, because the way to the head is opened through the heart."⁴ As things are the pupil may do 'thinking' enough, — or at least brow bending and brain racking, — but it is not his thinking; it is done 'for' Mr. or Miss So-and-so; it is a hired servant's thinking, and has little or no root in the student's own mind; even intellectually this is gravely injurious, as is well indicated by the poverty-stricken results in various studies,

¹ McDougall, *Physiological Psychology*, p. 129.

² James, *Psychology* (Briefer Course), p. 448. Betts, *The Mind and Its Education*, pp. 236-237; Münsterberg, *Psychology and the Teacher*, pp. 186-187.

³ *How we Think*, p. 54.

⁴ *Education for Citizenship*, p. 126. Chicago, 1911.

while in relation to moral culture it is ruinous. This heteronomous intellection leaves behind it no blessed legacy of mental power: this is why the college teacher is never done lamenting that the high school graduate has not learned to think; and no less does the high school teacher pass the condemnation on to the elementary grades."

In other words, the secret of better intellectual results and more effective moral training lie very close together, and both involve the fuller enlistment and activation of the will of the learner. We are anxious to make this point prominent at the outset: the advocacy of more attention to the moral aspect of education in the secondary period does not involve any diminution in intellectual achievement, but quite the opposite. We shall certainly reach the conclusion that the interests of the moral cultivation will demand some changes in the content of the program of studies, but its first and most essential aim is the vitalization of whatever the pupil does, including his intellectual pursuits; it demands that in them he shall always work at high efficiency, to the limits of his best capacities: this is the essence of moral training. The secondary teacher, being usually a college or university graduate, is likely to be primarily concerned for intellectual results, in spite of the article in the orthodox pedagogic creed declaring character to be the supreme aim of all education. We shall have some criticism to pass upon the teacher's intellectualism later: here we prefer to make peace with it, by making it clear that the first and most fundamental move in better moral training will be no less an advance in school pursuits, whether science, humanities, or vocational training.

THE MORAL ELEMENT PERVADES ALL. — Moral education, then, is in no sense a branch of education, and the attempt to treat it as such is the cause of endless fallacies and abuses, as well as most of the disputes and misunderstandings on the subject. Still less can it be a sort of addendum or appendix to the rest; it is truly the consummation and resultant

of all; it must enlist and employ all the activities of the child. The "branches" are all abstractions, each more or less separable, often, alas, isolated; but one thing is always present — the child himself — and always becoming what he is to be.

Least of all can there be a special teacher solely answerable for moral training, nor can any teacher of children or youth for one moment be absolved or discharged from responsibility for the culture of the will. Perhaps no point is more immediately vital to the existing secondary school and college situation.¹ Thus Rousseau says rightly: "There is only one science to be taught to children, namely, that of the duties of man." The whole task of education is moral; it is the guidance of the child into such performance of his own present childish duties that he shall grow into consciousness of the duties of his manhood, and into the possession of powers to discharge them.

THE WILL EXERCISES ON PROBLEMS. — The exercise of the will, then, demands a task or a *problem*, and the exercise of my will demands that I should have a problem. True, it may have been but now any one's problem, but before my will, as a real will, can act upon it, I must adopt it and make it for the time at least my very own. The true essence of moral education is the actual unmitigated and concrete operation of the will itself; all else is but preliminary, subordinate, auxiliary, and without this ends in nothing or less than nothing; other processes are worthy only as instruments or aids to arouse the sovereign act itself, or minister to its full performance.

Even at some risk, then, of the fallacies of conciseness, we may say that the essential method of moral education consists in helping the educand to grasp and solve his own problems, and to advance from those which he has by nature and through the stimulus of his present environment, to the perception,

¹ This does not, however, at all dispose of the question of moral or ethical lessons, with a place in the course of study and on the daily and weekly schedule.

adoption, and solution of the problems of his mature life in society.

The multifarious and confusing miscellany of ways and means in moral education, of methods, plans, decrees, instruction, and discipline, here find their unity, and their only possible justification. The test question must always be: What will aid the educand to solve his problems aright and move toward new ones, and so approach the perfected will? The fact is that just as in instruction the golden rule is, "Unless the mind of the learner works, all is in vain" — so in training, discipline, moral education of every kind, it is, "Unless the will of the educand acts all is in vain." Hence, just as instruction must wait upon and stimulate interest, will training operates through problems and action.

THE SOURCES OF ENERGY. — Another aspect of the question must be examined: character is character only by virtue of being endued with power, with dynamic force to enact itself against resistance. Hence moral training, as contrasted with mere intellectual or æsthetic culture, must needs make connection with the sources of energy in the educand. But the existence of a problem in the mind is exactly the best evidence of will energy ready to be released as soon as the appropriate channel or direction is determined. The youth is deliberating what he shall do: the very cause of the mental state is the underlying dynamic state. The persistency and intensity with which the problem holds the attention is a measure of the amount of potential energy stored behind it. Hence, if we can only discover the problem, we have located the forces demanded in the make-up of character.

Moreover, the personal relation of the teacher to his pupils is never so favorable and effective as when he helps them to solve their own problems; suspicion and aloofness are banished, the pupil's mind is open and eager, his heart is receptive and cordial, the teacher becomes truly what he so deeply desires to be, "guide, philosopher, and friend." One of the

most convincing collateral evidences of the correctness of this method of moral education is found in the countless actual cases of all shades and varieties, where a teacher or adviser does succeed in getting hold of the pupil and changing his conduct and his character just by showing him that a problem of his own is involved in the situation, and that for him the vital point is the solution of that problem. The idle boy is brought to see the probable effect of his indolence upon his own future, and the stern necessity of fostering a new habit of work; the disorderly or insubordinate is shown the larger social self, himself as he ought to be, and is awakened to cultivate that enhanced self; the youth who is set on leaving school against his parents' will comes to see that his life problem cannot be solved or even worked at without reckoning in those parents, their happiness and welfare. Let any one read any story of influence, Arnold at Rugby, Thring at Uppingham, Stableton in his little *Diary of a Western Schoolmaster*, Judge Lindsey, William G. George, dealing with normal or pathological cases, and he will find, practically without exception, that the method of success was to help the child to find and deal with his own problem, and so discover and confirm his true self.

THE BROADENING OF SYMPATHY. — Possibly, some one may apprehend egoism or individualism in such moral training, but this can only be on a superficial view; in the natural development of a human being his problems broaden to include more and more others; his affections widen as well as his knowledge, and wherever his affections fix themselves, there his problem is found. The larger social self grows by a process of development; even in infancy egoism is far from being sole determinant of thought and action, and in all healthy growth the narrower self is soon overgrown by a true human heart and will. All of this should become clearer as we consider the actual problems of youth, which is, *par excellence*, the era of socialization.

Perhaps we are fortunate in having to deal with adolescent youth, for even those who might think the foregoing statements extreme if applied to the training of small children can surely agree to their truth in respect to young people treading on the verge of manhood and womanhood, the vast majority of whose fellows of equal age have indeed already left the school for good and are doing adult work in the world.¹

One word of caution: the doctrine that we must train the will of the student through his own problems does not in the least imply that we are to abandon him to his own whims and caprices nor that his training is to be soft and indulgent; on the contrary, it demands that his real forces, now often squandered on specious and trivial pursuits which delude his immature and unaided vision, shall instead be devoted to the tasks which really lie along the true path of his growth and destiny; he will generate more energy, and apply it far more effectively than under any other system of training: he will work harder, endure more toil and hardship, overcome more obstacles, and vitalize and toughen his moral fiber, far beyond the measure of any forced and alien compulsion: and his powers will be his own, and will already be enlisted and organized under the command of his own purpose, indeed, in the cases of highest success, under the supreme leadership of the greatest and final phase of the will, a worthy life aim.

THE PROBLEMS OF YOUTH

WHAT ARE THE PROBLEMS? — The first task of moral education, then, is to penetrate the heart of youth and there discover its real problems. To what themes does his mind turn easily, naturally, irresistibly, as the needle turns to the pole? What are his uncompelled cogitations, his freest

¹ See J. K. Hart, *A Critical Study of Current Theories of Moral Education*, p. 36.

thoughts? To what does his inner consciousness swing in repose, or even against the external calls of duty, of work, of study, of parental, pedagogical, or occupational pressure? Above all, what is he anxious and concerned about, what is he eager to achieve or compass, in what does he think to find joy, and in what does he dread to endure loss and failure? To the discovery of these secret currents of the souls of youth must we devote all our sympathy, and no less all our wisdom, even shrewdness. And this not merely to indulge these native tendencies; certainly not, as is too much the fashion, to laugh at them; not even to be content with them as they are; but to utilize them. They are the data of the will, the sources of both power and direction. Out of them, or out of nothing, must the full-grown human will develop. We are dealing here, as it were, with the natural history of the adolescent will.¹

The scientific treatment of such a field is infinitely difficult and is certainly as yet in its infancy. Adolescence is the high point of modesty and reticence. This need by no means surprise us, inasmuch as the two most prolific sources of the inner consciousness and problems of youth are, as we shall see more fully later, the sentiment of self, and the new elements of sex life, both of which are exceedingly affected by the sentiment of modesty.

SOURCES OF INFORMATION. — What, then, are the sources of information as to the consciousness of adolescence? First, the recollections of our own youth; this not only gives us the only possible immediate knowledge we can have on the subject, secure from all fallacies of communication or interpretation, but it gives us the clew by which we may grasp and interpret all other available knowledge. Probably nothing is more invaluable to the teachers of youth than that they should themselves have lived a full, rich, and normal adolescence, and should keep an ever-living memory thereof. Only

¹ Scott, *Social Education*, pp. 36, 37.

thus can we hope for even a beginning of comprehension and sympathy for our students.¹

Of course the students themselves are the second source of information. Other knowledge is useful to interpret, check up, and perhaps supplement, but this furnishes the real data of our problem. The high school teacher needs to study his own pupils outside of the classroom work; play of volition is far fuller and more typical there than in the schoolroom under any ordinary conditions. There are rich sources of knowledge almost unworked; for example, athletics and social life. As to the former the teachers fall mostly into two classes — some preserve an adolescent attitude of uncritical enthusiasm; others grow gradually into a sort of jealous hostility, sometimes so mild as to appear as mere indifference, sometimes very intense. Both classes fail to study the phenomena in any profitable manner. A conspicuous feature of the social life has been the fraternity; high school workers have devoted much earnest thought to the external, administrative problem involved, and have been led generally into relentless war upon the organizations, sometimes resulting in bitter conflicts requiring the aid of the courts to settle them. Practically all the best friends of the high schools are against the fraternities, and agree that the school authorities are right in exterminating them. But we have not properly studied the phenomena involved, as manifesting in extreme form some of the characteristic elements of adolescent volition. We must extend our inquiry beyond the more external symptoms of snobbery, insubordination, dissipation, and general deterioration, and investigate the impulses and volitional forces, in the individual boy and in the group, that underlie and explain the boys' intense, almost furious devotion to their society and to the fraternity idea. These impulses and forces are in themselves good, and need not to be destroyed but to be guided.

¹ On the tendency to forget one's own adolescence, see Hall, *Youth*, pp. 144-145.

Doubtless there is some help to be found in literature. The immense mass of descriptive and statistical matter in the literature of the Hall school will naturally come first to mind. Most of us must take it with some caution, and probably in rather moderate doses, for the simple reason that it runs much to the abnormal and pathological. Yet it is the only considerable effort yet made to study youth by scientific and especially by biological methods; and these methods seem indispensable in the study of volition. It is safe to say that no earnest student of high school education can afford to ignore this source. Two books must be mentioned as highly prophetic and interpretative, as well as powerfully inspiring — Jane Addams' *Spirit of Youth and Our City Streets*, and Charles Wagner's *Youth*. Then there are accounts of methods of dealing with adolescents, and of their responses to these methods. The lives of Arnold and Thring are invaluable; before the days of adolescent psychology they perceived and utilized the laws of the volitional life of boys. In our own days numerous accounts of boys' clubs, school cities, and other juvenile activities, furnish pertinent and often valuable data. The George Junior Republic is a fascinating study in not-quite-normal adolescence, to be taken, doubtless, with some caution; juvenile court experience is a profitable study. Exceedingly valuable in this field are the methods and experiences recorded in Reeder's *How Two Hundred Children Live and Learn*, and, with still closer relation to school life, Stableton's *Diary of a Western Schoolmaster*.

THE LARGER LIFE. — The school or the teacher who thinks only in terms of school reckons without his host. The bigger world already has the eye and ear of the youth; his problems are all determined by the forms of life into which he feels himself swiftly moving. His most personal ideals are meant in the last analysis to conform or to please; his diversions are not solitary but love the group or even the crowd; his calling will be one of the functions that society has ready

made for him; even his religion will come from the minds and hearts of many now living and more who have passed away. No less social are the means at the hand of the school for guiding the youth in solving his problems. It is easy for the educator to throw away his labors by building what the rushing forces of life will sweep quickly away; — nay, the currents of life, unperceived by his academic vision, may be carrying away his foundations while he is laying them.

Our athletic affairs are molded by the national situation; the old village green, where the many played and a few old folk and infants looked on, has been changed to the baseball or football park, where a handful of professionals are exhibited in an arena, while thousands sit in pathological super-excitement, with every normal avenue of expression choked up, and all the efferent nerve currents poured into flushed and distorted faces or furious vociferation. College and high school have been drawn into the vortex, and the flower of the young men are often sacrificed in one way or another to “make a Roman holiday.” The incoherent cries of the “fan” are organized under the “yell leader,” and an athletic liturgy is consecrated out of noise. Until society at large awakens to the truth of the matter it will be hard to reform athletics and rehabilitate physical education in schools and colleges. An exceedingly close parallel may be drawn for social life in general, involving such matters as dress, dances, parties, fraternities, smoking, and the like.

On the other hand, the big world is full of constructive forces. The people in general are on the side of the right, especially when it affects their children’s training and future. Business, with all its vices, and work, with all its imperfections, are great educative forces that have raised man above savagery and contributed to the education of all generations. The chief vice of the public with reference to the school is ignorance and neglect; the great task of the school administrator in this respect is to awaken and enlighten public opinion, and enlist

its aid in maintaining the moral conditions in and out of school that are the indispensable ground and support of moral education in the school.

THE POINT OF CONTACT. — The actual point of contact between educator and educand, the problem itself, and the exact form or aspect of the problem, depend greatly upon the subtle, indefinable, yet most real relation between the two persons concerned. To discover and vitalize this contact is the supreme art of influence, in which any large success comes only through what may figuratively be called in words of Jesus "fasting and much prayer," that is, deep and self-effacing devotion. This is perhaps the reason why so many wise and earnest thinkers are unwilling to admit any definite or would-be scientific treatment of the problem of moral training, and assign everything to the "personality of the teacher." It is this also which leads even Herbart, the great prophet of a completely mechanized pedagogy, after he has expounded all his principles and formulated all his rules, to discuss Tact at some length as the indispensable attitude, incommunicable and defying all analysis and description, which must guide and animate any method whatsoever if real success is to be achieved. It would be foolish to deny or belittle the importance of personality and tact as emphasized by these and similar statements; but we must resist their more extreme forms, and insist on believing in the ultimate possibility of a scientific solution of even the problem of moral training, on the ground that we are confronted not with an irrational or inherently incalculable activity, but only with an exceedingly complex one.

THE GREAT PROBLEMS. — When we undertake any descriptive account of the problems of youth, it is easy to enumerate concrete and definite things that the adolescent undertakes and for which he will labor most strenuously;¹ "making the team" is perhaps the most striking; keep-

¹See, for example, Hall, *Youth*, Chap. 8, Biographers of Youth.

ing his standing with his fellows is another; earning money is often another; very commonly he gives much and conscious thought to his personal appearance and dress; any conduct that is considered loyalty to the school can usually command his best efforts; he sometimes, and she oftener, will expend great efforts, even to the point of overstrain and injury, in order to keep up in scholarship; and so on through an indefinite list. Such things as these are the original data, careful observation and description of which are the prerequisite of any scientific treatment.

While there is much variety of opinion as to details, there is general recognition of the idea that these adolescent tendencies group themselves largely about four or five great problems; for practical discussion we present a rough outline of these.

The first is the discovery and perfection of the Self, both individual and social, which, in its broad sense, evidently includes all other possible problems; next amusement, recreation, "fun," in a vast variety of forms; then two that belong peculiarly to adolescence: first, relation to the other sex, involving sexual life itself, love, marriage, and family; then vocation and economic success, rising into the ideal of a life career. The fifth great choice is a religion, not at all in the theological but in the ethical sense, — something which dominates the whole hierarchy of will, forms the object of supreme desire, and so assimilates to itself all other motives. These great questions are being asked more or less definitely by young people everywhere; nowhere, it is natural to suppose, more than in high schools. They may be put into words somewhat thus: (1) "What sort of person am I going to be?" (2) "How am I going to find my amusement, spend my leisure time?" (3) "What attitude am I going to take toward women (or men)?" (4) "What shall I do for a living?" or more naïvely, "How am I going to make money?" and finally, though far less likely to take any definite or even conscious form, (5) "What am I going to put above everything else? What am I going to serve with all my heart?"

THE GREAT DETERMINATIONS

THE REALIZATION OF THE SELF. — Of the five great adolescent will activities only one has been generally recognized by formal education, that is, the first, self-development and perfection; and this in a comparatively narrow and feeble form. Much stress has been laid by the school upon the intellectual progress of the pupil, and that with constant emphasis upon his remote future welfare and success. Of course such an appeal is legitimate and not without effect. But it is subject to at least three serious weaknesses: first, the normal youth is not yet effectively concerned for his scholastic achievement; second, his will needs not a remote but an immediate stimulus; and third, the youth who most needs guidance and stimulus will almost always be least affected by the intellectual ideal.

Physique. — On the other hand, the powerful impulse toward physical strength, beauty, grace, efficiency, prowess, has been allowed to run largely to waste, or even to militate against the avowed aims of the school.¹ The case of school athletics is too familiar to need rehearsal here; but it is impossible that we should gain our moral ends with high school youth unless we avail ourselves of the potent athletic impulse; the early adolescent will make any sacrifices, endure any labors, perform the incredible, — as every coach knows, — to demonstrate his manly powers to himself and his fellows. The question is no mere physiological one, — a human body is a psycho-physical thing; our most serious loss at present is the loss of psychic results obtainable but not obtained from physical action.

The mere catharsis of a vigorous bodily regimen is indispensable; every student of boys knows how their “animal spirits,” — lacking which they would be less than men, —

¹ See G. Stanley Hall, *Psychology of Physical Education, Proceedings N. E. A.*, 1910, p. 297.

if denied full and free vent in abundant and exhilarating exercise, break out in disorder, "rough-house," insubordination, and even rebellion. And there is probably a far more serious evil that eludes most observers, in that the less bold and dynamic youth fall into secret vices that sap their forces ere they develop; against self-abuse and degenerating vice in general, the most universal safeguard is certainly a bodily regimen, vigorous and virile even to excess. A life which sends the lad to bed regularly and healthily tired but not exhausted, with muscles and nerves and organs purged by abundant exercise, gives scant play to any perverted or noxious impulse or habit.

Moreover, great as is this advantage, it is but the negative side of the benefits of proper physical regimen; the positive results include a just confidence in one's bodily powers, invaluable balance of the psychic constitution, endurance, courage, the physiological basis of optimism. The social values of athletic sports, in their normal forms, are too great to discuss here; we do not hesitate to say that one of the first duties of curriculum makers is to study earnestly and without prejudice the educative influence of play and recreation. It is passing strange that a culture that claims descent from the Greeks and professes sincere admiration for their achievements should so completely despise the gymnastic element that made good half of their training of the young. What would the Greeks have thought of a school for adolescents that assigned either no single instructor or at best a meager one or two in a hundred to the education through bodily exercise? Yet that is the status of our high schools; even in a progressive school, out of fifty teachers it is rare that more than two or three are charged with physical culture. Too often even these are looked upon as outsiders or underlings by the "academic teachers"; almost universally they are selected and utilized, not for the true physical development of the whole group of youth in the school, but to plan and exe-

cute the spectacular exploitation of a few who least need their help.¹

Intellectual Initiative. — On the side of the student's self-development that the school has emphasized, the intellectual, the great need is the awakening of the student's own initiative and energy. Attention should be fixed less upon externals, such as the performance of set tasks and the gaining of marks, and more upon the essential thing of the youth's sense of his own growing powers of thought.²

Above all we need to revise our present system of "passing" and "failing," by which the individual of high capacity is practically encouraged to loaf along at any half-speed that will keep his head above water academically. Each must be incited constantly to do his best, quite regardless whether that best is marked "A" or "X" in the school records. We might do worse than borrow a maxim from the trainer of trotting horses "to make the colt go his pace for his distance"; as things are, we virtually suggest to the fast colt to go the slow colt's pace for the slow colt's distance. It is ruinous for the human colt to habituate himself to an achievement below his capacity, no matter what the achievement may be in itself, for so he tends to decrease his powers; toward increase of power there is but one road, the doing of one's present best, nay more, one must ever surpass one's best, do the impossible, rise to a new level of power and confidence.

¹ See the writer's *The High School's Cure of Souls*, *Educ. Rev.*, April, 1908, pp. 364-365; and *Essentials of Character*, Macmillan, pp. 115-116, 98-102.

² "As a matter of fact the moral exercise of the will is not found in the external assumption of any posture, and the formation of moral habits cannot be identified with the ability to show up results at the demand of another. . . . The question of moral training has not been touched until we know what the child has been internally occupied with, what the predominating direction of his attention, his feelings, his disposition has been while engaged upon this task. If the task has appealed to him merely as a task, it is as certain psychologically as the law of action and reaction is physically that the child is simply engaged in acquiring a habit of divided attention." Dewey, *Interest as Related to Will*, p. 9.

Morally no less than intellectually it is a sore point that our intellectual culture fails signally to produce intellectual interests which are will characteristics as well as intellectual, and which are after all the only true results ; all else, — for instance, any acquisition of information or knowledge, — being mere preliminary or instrumental processes. It is a moral loss quite as much as an intellectual one when the student turns away, at the end of a course in English or mathematics or science, with a sigh of relief and throws away his book and his thoughts on the subject, more than satisfied to say that he has “ had ” it.

This brings us from another angle to the same insistent but ignored truth, that intellectual results cannot be achieved without the vitalization of the learner's own will ; the heart of instruction is interest, which is the very essence of the “ new education,” and interest is nothing more or less than the enlistment of the learner's own will. The upward road for better moral training is exactly the same as that to better thinking and more intellectual mastery. The sooner both secondary and college teaching take this truth into their reckoning and let it operate fully on their methods, and upon their curricula, the sooner will they approach the heights of intellectual success they so greatly and sincerely desire.¹

Personal Ideals. — The youth's problem of honor is the decision of what he will admit and what he will reject from his innermost self, his code of conduct. What is he to love and practice, and what is he to hate and eschew? He is blessed with abundant instincts of honor ; chief among them is loyalty to his fellows, especially when a conflict with some adult authority or power is involved. Another is the ideal of courage and the utter hatred and abomination of cowardice. How resistless these impulses are no words can adequately express ; the whole soul and body of the healthy and vigorous youth

¹ An interesting testimony to this is found in the first few paragraphs of Dr. Eliot's *The Value during Education of the Life-career Motive*. *N. E. A. Proceedings*, 1910, 133 ff.

responds to them. They are strong enough to tear him from school or even home, to drag him through danger and pain. They are the mainsprings of that great adolescent ethics of the race, chivalry, and are the promise in the modern youth of both the good and the evil of medieval knighthood.¹

The fatal error in dealing with adolescent honor, even in its most inconvenient forms, is to quarrel with it; the path of success is first of all through an understanding of it that is both clear and sympathetic: clear in seeing its confusion and narrowness, sympathetic in having a warm and abiding sense of its appeal and preciousness to the youth himself. Then comes enlightenment; the universal rôle of thought must be played here, and the youth must look out and beyond, must see the interests and welfare of all affected: first, those of the "outsiders" from his point of view,—the teacher, the man whose windows are broken or whose trees have been robbed; too often — alas, for our sportmanship! — the opposing athletic team, the pitcher trying to hold his nerve at a crucial point or the quarterback struggling to rally his demoralized team. Then he must, and thus will, see the interests of himself and his own clique or crowd, in a new and larger way. Thus, and thus only, may the abundant and priceless energy of his impulses of honor be enlisted in the service of the larger and truer right. But let the teacher never doubt that in its crudest form the impulse itself is at bottom good, so good that without its aid there is no possibility of the realization of the best character in the man that is to grow out of the boy.

VOCATION. — The vocation motive is happily coming to its own in these days. We may hope that the school is soon to perceive in a true and profound way the wisdom of the answer of the old Spartan king, who, when asked what boys should study in school, answered, "I suppose that which being

¹ For a most interesting symposium on this subject see "Who Broke the Window" in several numbers of the *Outlook* for 1913 and "Good, Bad, and 'Daddy George'" in the *Survey*, August 2, 1913, pp. 565-566.

men they shall do." No narrow view of this element will suffice; such views have already deformed the practice of some vocational schools, and repelled many earnest but conservatively minded friends of education. We cannot accept without scrutiny the views of the manufacturer and the business man who are mainly concerned to increase the number and quality of operatives or clerks; we cannot agree with the dictum that "A boy who is to be a carpenter should continue in all stages of his educational course to make manual training of this sort his most important occupation." We are here concerned, not with the making of carpenters, but the making of men. Hence we urge more stress upon the vocational element and motive in schools because it vitalizes and energizes the whole school life of the student; it puts into his "studies" what in other cases is found only in his "activities," — spontaneous, self-feeding interest, — and this means moral growth instead of atrophy and decay. We do not hesitate to say that a survey of the educational field would show that the most potent single force for interest in secondary and higher education even now is the vocational motive. The superior performance of professional students over "liberal arts" men is a notorious fact; the vocational school manifests, even to the casual observer, a warmth and personality of interest among the students that the general secondary school cannot equal.

To us adults things must mean something if they are to gain our attention and effort; no less so with children. One of the simplest and most immediate sources of meaning to the secondary student is relation to his life work. He is going to do a vast amount of thinking on this subject, whether or not the teacher knows or cares. Before and after leaving high school he will canvass vocation, — not wisely, not broadly, not intelligently; to his unaided reflection it will be mainly a question of "making money"; even the best of lads have either little or no perception of the great rich *social* aspect of any man's

calling. Here are then two great opportunities of the school: to utilize the impulse that flows from the vocation motive, turning it into channels of mental and technical advancement; and to enlighten the impulse itself, helping the youth to see vocation in its bearings upon life as a whole, and especially as one of his most important relations to the great world of human life and common welfare.¹

Effect upon the Curriculum. — Of intense interest to every high school teacher, and indeed to all friends of education, is the question how this vocational principle is to affect the present curriculum and methods of the schools. We have already proposed a general principle by which all school activities must be tested: Do they aid the pupil in grasping and solving his problems? So far as vocation is concerned it seems increasingly sure that many things now not in the curriculum possess great capacity to aid the educand in solving this vital, vocational problem and will inevitably demand and obtain, against any resistance whatsoever, entrance into the school. This is true of many industrial and technical activities; and it is no less true of some studies, not in themselves contributing to the technique of any calling, but shedding light upon vocation as a whole, and upon the relations of vocations to each other and to economics, ethics, politics, and any other great aspect of life in which the student must orient himself. It would seem that the worker in the field of secondary education should prepare himself for far-reaching and radical, though gradual, changes in the secondary program of studies in these directions.

Vocational Guidance. — Most immediately hopeful and practicable for moral effect is the field of vocational guidance. This need not wait upon costly equipment and sweeping changes of personnel and methods: it demands only the enlistment of the hearts and intelligence of considerable numbers of teachers and other sincere friends of youth. The egregious

¹ See chapter on "Social and Economic Gains through Vocational Guidance," in Bloomfield, *Vocational Guidance of Youth*, especially pp. 112-113.

blunder of letting our boys and girls drift or be thrust into callings without any rational consideration of the questions involved need not remain longer without some remedy. Few possible educative methods are so pregnant with good as this. It does far more than aid the pupil to solve one of his most pressing and fateful questions; it engenders between youth and adviser a relation of sympathy and understanding that is the best possible avenue of all kinds of moral aid and enlightenment. It provides, probably, the easiest good road to the heart of the educand. And it is twice blessed, — it blesses the teacher who gives no less than the pupil who receives. Few things in the high school situation are more to be desired than the opening up of paths of sympathetic intimacy between teacher and pupil, along which may pass freely the educative benefits which now too often lie choked up or inert in the teacher's soul.¹

THE ZEST OF LIFE. — We come next to two great neglected moral forces, recreation and the intersexual nature and life. In both of these, happily, awakening seems at hand. Jane Addams' *Spirit of Youth and our City Streets* is a veritable challenge to all who are concerned in the welfare of young people of both sexes. It is true that it deals most directly with young people who are not in school or college: yet the essential nature of youth is the same in both classes, and it is probably true of high school boys, as Miss Addams says of working youth, that "recreation is stronger than vice, and recreation alone can stifle the lust for vice." Most assuredly the modern high school needs to take a page from the philosophy of the Greeks and from the educational practice of the Greeks and readopt play and recreation as an indispensable and potent educative force. The very exuberance of play is proof enough of its power to leave its mark on the

¹ On this whole problem see Eliot, *Value during Education of Life-career Motive*, *Proceedings, N. E. A.*, 1910, pp. 133 ff.; Kerschensteiner, *Education for Citizenship*, Chicago Commercial Club, 1911; Gillette, *Vocational Guidance*, Chicago, 1910; Bloomfield, *Vocational Guidance of Youth*, Boston, 1911.

fiber of the organism. Nowhere else does the educative cycle run so swiftly and intensely through its full course of stimulus, decision, and response. Nowhere is the "trace on brain and nerve" more certainly and deeply marked. Profoundly formative recreation is, whatever the educator may do about it: the task that lies before us is to control its power and make it educative. This is, as we have already suggested, the great, almost the only real problem in school athletics.

The social aspects of recreation extend far beyond the school, and responsibility for them must be borne primarily and ultimately by the home. Yet we may well inquire whether the school has not a part to play. It has taken no small hand in settling the school fraternity matter: possibly with a little too much regard for the institutional welfare of the school itself, and rather too little consideration of the instincts and nature of the young people themselves. We suggest two other means at its disposal. The first is closer coöperation with the home; here we are met at once with the complaint of lack of time for such relations, especially in our huge and crowded city schools, — where it is perhaps most needed. The answer is not so impossible as it may seem, — sacrifice something else; let the teacher be authorized, nay instructed, to throw quiz or exercise papers into the waste basket any time, if needed, to allow time to talk with parents about the welfare of their children. It is high time that the secondary teacher be freed from the academic strait-jacket of prescriptions and requirements of laborious detail, of endless reading of papers, and become a teacher and friend, no longer a mere quizmaster and indexer of grades. How can we hope to help the growing boy and girl when their two chief educators — parent and teacher — do not even know each other by sight, and when home and school are mutually ignorant of each other's aims, ideals, methods, and attitudes?

It is hard to understand the slowness of school authorities to avail themselves of the parents' meeting to aid in this respect.

Difficulties and some risks there certainly are in the way of parent meetings, but so there are in any really worth while action. They can be and are being overcome. The problem of social life and recreation will be solved only through joint and harmonious action of school and home.

MUTUAL RELATIONS OF THE SEXES. — Sex education is properly a chapter by itself in educational progress: something must be said of it from the point of view of moral training. There are two great motives for the control of sex life by which the lower or physiological impulse is regulated by the higher human elements. The first is the desire for individual strength and perfection, especially in the case of the adolescent boy, the intense ambition to be virile, athletic, well grown, to surpass in bodily prowess. This impulse, and the actual physical catharsis of an athletic regimen, are the great bulwark against all forms of secret vice. But these are inadequate, as are all individualistic motives in every field of morality: above and beyond it comes the ideal of personal honor, of chivalry, merging into the potent impulses of marriage and family. Marriage and parenthood are the evolutionary and racial solution and elevation of sex, and must be so for the individual. Let this expectation of being a husband and a father be a part of the conscious thought of youth, mingling in his mind with his hopes and ambitions to be a worth-while in other fields, such as economic success and civic duty.

Honor and Ideals. — The thing needed is an attitude toward the other sex that can bear scrutiny: there are ways of appeal that no healthy boy can resist, — “It should be impressed on every boy that every girl is somebody’s sister, and that it is his sacred duty to afford her the same respect and protection which he would expect from another boy to his sister.”¹ Charles Wagner puts irresistibly the course of thinking for the young man which leads him to the only possible conclusion: “The rule of conduct here is chastity. Every

¹ *The Survey*, Nov. 16, 1911, p. 193.

infraction is a sin. Though this law may seem difficult and severe it is the only safe one. Morality without it is rubbish.”¹

The promise and potency of these high ideals is found in a field despised and neglected by the educator, and arousing in the rest of the adult world mainly the laughter of fools—the early love of the adolescent, perhaps the purest and most ethereal experience, next to motherhood, that most human beings ever experience. No description can overstate its charms: “It is a morning land full of bursting flowers, bathed in the sunshine and the dew, a pure and virgin soil where no foot has trod, where no dust and stain have come. It is a land where love is born amid the friendships, the smiles, the sports of youth. . . . It lies at the threshold of our life, like a radiant paradise where the joy of living, of seeing, of worshipping reverently from afar, and oftenest without telling our love, suffices us. We have closed this paradise. We must reopen it and teach our youth to desire it.”²

Just how this great force is to be utilized is certainly far from clear: but it is one of the most undeniable problems of education, especially in the secondary period, which usually contains the climacteric of adolescent love. Already many individual cases have operated for good, and not a few for injury in actual school work; many a high school teacher has known of boys awakened to new interest and energy by falling in love with some good girl who perhaps was inclined to take her studies seriously.

A Gap in the Curriculum. — Spencer long ago held up to sarcastic comment the failure of the school to make any preparation for the business that nine tenths of the educands must some day engage in, — the rearing of a family. The curriculum, he says, gives the impression of having been planned for some celibate order, rather than for the common run of men and women. The moral educator must recognize that to turn out good men we must needs form good fathers. Some day we may

¹ *Youth*, p. 250.

² *Youth*, p. 258.

hope for an education that will nurture the impulses of sex and love into their normal fruition in inspired and intelligent parenthood and family life. At present, the most that we do is to curse the ignorance and neglect of the average parent, which is, after all, merely the natural result of education as it is.

WAYS AND MEANS

The crucial test of all methods of moral training is clear from all our preceding consideration: whatever awakens and exercises the student's own will cultivates his character. The best friend of a youth is he who makes him do most. But the doing must be of the will and not merely of legs and hands. The actual instruments of training in the school have been stated by Professor Dewey as (1) the life of the school as a social institution in itself; (2) methods of learning and doing work; (3) the school studies or curriculum.¹ As things are, it is well to insert a fourth division, school government. Let us consider them in this order.

SCHOOL LIFE. — "The moral life," it has been said, "is the response that the individual makes to the social order in which he lives." In proportion as the school hours become part and parcel of the main flow of the student's spiritual existence do they contribute to his moral growth. The great task for the secondary school with respect to its "life," is to inform all the activities, study, recreation, athletics, social affairs, with a wholesome morale, so that in them all the will of the youth is acting as we desire it to act in his mature life.

It is quite clear that one of the first requisites here is the cordial and intimate participation of teachers in the life of the school. Education, as Professor Palmer has so well said, is a "dependent fellowship" in which the elder and wiser enlightens and aids the younger. Boys and girls need such help quite as much in their recreation and diversions, their athletics,

¹ Dewey, *Ethical Principles underlying Education*, p. 26.

social functions, journalism, as in algebra and chemistry. The modern secondary teacher is tempted, almost compelled, to content himself with being a philosopher to his pupils and never attaining his more influential relation of guide and friend. But that the relation is possible is proved by the few who do attain it in high measure, — the teacher to whom the students come for counsel about their dances, their school paper, and all the miscellaneous quasi-personal details of life outside of the curriculum.

It must be admitted that the huge high schools toward which we are so rapidly tending are utterly unfavorable to such moral relations; the testimony of high school students themselves indicates that a human companionship between teacher and students is not uncommon in the small town or rural school but almost unknown in the great metropolitan institution.¹

SCHOOL GOVERNMENT. — Student self-government is nowadays a much mooted subject; with many it is a phrase to conjure with, to others it is a fad with which innovators entertain themselves. That the student should wisely govern himself is certainly the supreme end of his education; whatever causes him to govern his own conduct in school trains him toward this end. The most advanced theory, by no means unsupported by practical experience, is that the body of pupils should come to feel thoroughly responsible for the social order of the school. This is actually realized in higher education in at least one conspicuous case; many secondary and even elementary schools at least approximate this condition.

From the point of view of moral training, to which we are here confined, two or three things may be said as to the present situation: first, no one should pretend, and in the successful cases no one does pretend, that the students wield any final authority; no one knows better than the students that the legally constituted authorities cannot, if they would, abdicate

¹ *School Review*, December, 1912, pp. 657-659, 663.

their posts or shuffle off their responsibility. But the students are perfectly satisfied to be allowed to conduct their affairs, subject to revision by the faculty; and experience shows abundantly that under right conditions they can and do get along for indefinite periods, dealing with various and difficult matters, without needing any official revision from above.

On the other hand, any one who expects such a system to create itself in a high school, or run after it is created without most earnest and vigilant care, is likely to suffer a rude disenchantment. But the work to be done is not mechanical or routine, it is spiritual, communicative, intimate; its great purpose is to awaken in the minds of the youth the ambition to be autonomous; and enlighten them as to the true nature of the end and the effective means of attaining it. Indeed the "system" is the least important part; many a school has genuine student self-government, in the wills of individuals and in the body politic, without any machinery; and the finest system might conceivably lack the true spirit and so be futile.

One practically demonstrated means toward these ends is the maintenance of joint boards or committees composed of teachers representing the faculty and students elected by the whole school or sections of it.¹ These boards should be given *real* things to do and real powers. They constitute an invaluable channel of intercommunication between faculty and students, the value of which is realized when we consider the fact that the most serious disaffections arise in school life as elsewhere through *misunderstanding*.

Actual experience with any healthy form of student participation in government will strengthen the teacher's indispensable faith in the soundness of the real heart of youth in all vital matters. In fact, the student council or court not seldom takes so ideal and rigoristic a view of conduct as to call for some interposition of clemency from the faculty. The great

¹ See for example the Board of Athletics and the Council at Bradley Polytechnic Institute, Peoria, Illinois (described in catalogue, *q.v.*).

moral value of all plans of real student control is in their power to call forth and exercise the social and ethical will and intelligence of all concerned.

SCHOOL WORK. — The most effective educator — though we may have to ask sometimes to what good end? — is the athletic coach; for he spurs and goads his charges with the discovery, indeed the creation, of new powers in themselves. It might be well for the academic instructors to go out and see the football practice, not with any care as to the next match game, but to see how the lads add to their power and skill by outdoing their previous possibilities.

It is the immense educative value of industry, of application, of relentless persistence, in brief, of every form of hard work, that has led to the almost universal faith in "disciplinary" studies and that probably accounts for much that is attributed to "formal training." Many wise educators have quoted approvingly that old saying that "the best thing in education is doing the thing you don't want to do at the time when you don't want to do it." The truth is — paradoxical only in form and because of the poverty of words — that real power is gained only through wanting to do the thing you don't want to do, and doing it because the "don't want" is superficial and temporary, while the "want" is essential and permanent.

This is the reconciliation of interest and effort; and every one knows that the maximum of endeavor is attained, not through external compulsion, but through desire and ambition from within.

Yet it is true that few things are more needed in the American school, in all grades, than more effort and application, more thoroughness and mastery. The youth must learn that educationally also "the Kingdom of Heaven suffereth violence, and the violent — that is, the energetic and resolute — take it by force."

When we ask then how the young people shall work in high school, we may answer, first, hard, very hard; this is the

gymnastic of the mind, the only way leading to the powers of concentration and mastery. But also successfully and joyfully; learning to fail, so common now, must be reduced to a minimum. To this end they must work intelligently, with some sense of purpose and hope of reward. Finally, they must work socially, in school, as in life; here is one of the easiest routes of advance, because the present practice is so crudely individualistic. The isolation of the pupil in school has long been held up to censure, but yields very slowly to improvement. To help each other, the chief virtue of real life, is a misdemeanor in school. Doubtless there are causes for this insistence upon individual work; no one wants John to do James' work; that is no coöperation at all; what we do want and must have is a kind of work in which each can do his own part, in contact and relation with all the rest. Only thus can the young worker learn the indispensable virtues of adjustment, consideration, practical coördination; it is time the school did its share in the production of these traits.

STUDIES. — After all, as things are, and as they are likely to be for some time to come, the bulk of the school's time and attention is given to the curriculum. All past ages have had great faith in the moral power of studies: *abeunt studia in mores* said the Roman writer, and Bacon quotes the saying approvingly; but nowadays the educational world is full of skepticism concerning the effect of the curriculum on character. We have space for very brief discussion. First, let us be quite clear that the *studia* of the Latin proverb are not mere formal branches of learning, subjects in the school program; the word study, which Bacon and Milton use in its original sense, has fallen from its high estate; a study, truly speaking, is an earnest pursuit, a zealous and devoted occupation of the mind; Milton speaks of "the study of learning" as we would say the love of learning. It is in this that the truth of the saying lies, for the basic fact of the formation of character is just this: that our earnest pursuits pass over into habit and

attitude and so form the very essence of our morals. This then is nothing more than a reiteration of what was said in the preceding paragraph on how pupils should work, — hard, resolutely, joyfully. Let us be sure that no other kind of “study” has any great chance of passing into morals.

Moral Values. — Having agreed in great measure with the disciplinarians on the importance of how children study, we differ absolutely with those who belittle the question of what they shall study. The moral and in general the practical value of studies varies enormously, depending upon the directness of their application to the life that the adult is to lead. The secondary course stands in need of merciless scrutiny and appraisal in this respect. Let us follow Plato’s example, who, disregarding even the most sacred traditions, chooses and rejects from every source, not excepting Homer himself, according as the subject matter fosters virtue or its opposite.

Two great fields at once present themselves as peculiarly ethical: history and literature. These both deal direct with human life; they are the humanities, and as such must constitute the chief part of the moral studies. With history must be included the study of the present as well as the past; also the related sciences of economics, politics, and ethics, — all in so far as they can be dealt with in the secondary period; and the elements of all can be so used. Literature we include without regard to the language in which it is written or read; hence much that is now set down as language study — which is something utterly different — is here included. In other words, this is really the question of the classics, without which, rightly understood, there can be no liberal education, as has been so often and so warmly declared.

The Classics. — As to the classics themselves, the humanities, Milton forever voiced the view of their precious power that has been the spring of all the passionate devotion which they have excited from the days of the revival of learning until now;

through them, says he, in his Tractate, the boys are to "be inflamed with the study of learning and the admiration of virtue, stirred up with high hopes of living to be brave men and worthy patriots, dear to God and famous to all ages," and more to the same inspiring effect. This was the view of Vittorino and Erasmus and Ascham before Milton's day, and of Arnold and Thring since. On such a view it is easy to justify the great space in the curriculum given historically to the classics. But on such a view the teacher of the classics — in whatsoever language, Greek or German or mother tongue — must be mainly not an instructor in language but an interpreter of man and his life, as bodied forth in the literature in hand. This is humanism, and such a study as this does most truly pass into character. How far, in the opinion of at least one expert, we are from this lofty ideal, may be read in Gayley's *Idols of Education* (pp. 108 ff. and *passim*).

Heroes. — We have almost forgotten in these days the true educative use of great men, so well known to earlier times; the figures of our own national heroes are almost unknown in their true form to the vast majority of our people. By actual test college students are quite ignorant of the essential facts in the life of Lincoln, and could give no sort of adequate reason for our placing him at the top of our list of great Americans. The truth is that the life and character of Lincoln form one of the most potent educative instruments at our hand, in the vital task of perpetuating and elevating ideals of genuine Americanism. But our young people must know him truly and intimately; as it is they have a few scraps of information and error mixed and floating about in their minds to no spiritual purpose.

Let room be made in the course for more history, especially of our own country; and let room be made in the history, — by omitting great masses of material now learned only to be immediately forgotten, — for extended and inspiring contact with great figures; besides our own great, — Columbus,

Washington, Lincoln, and a few others, — there should be an acquaintance with the *virī mundi*, the supremely great of all ages and races, Moses, Socrates, Pericles, Regulus, Alfred the Great, Charlemagne, Cavour. These happen to be rulers and statesmen, but there should also be scientists like Darwin, inventors like Palissy, reformers like Luther, men who have “enlarged the known powers of man” in any field, and, above all, who have greatly served.

The true Shekinah, some one has said, is Man: all ideals of life and conduct, all ethical truths, are seen perfectly only when embodied in man himself; this is the principle of incarnation, of the revelation of God in man, of the Divine Word made flesh. Educationally, this principle is doubly potent, for the human figure has power to fascinate the attention and enchain the heart of youth; so personalities carry at once the content and the enforcement of moral truth. The high school period is the last chance for such spiritual effects, and probably the best; it is a valley of decision with respect to ideals and principles; the elementary pupil lacks the breadth of mental horizon to enable him either to comprehend or feel the essential greatness of most educative figures; the young man beyond the high school age, whether in college or in life, has closed most of the questions involved, and is little affected by the influence of ideal personalities. This is the opportunity and the responsibility of the secondary period.

The New Order. — But let us not lose sight of the new humanities: the youth of to-day are looking out on a new world, with economic, industrial, political, social ideals and attitudes that were only vaguely dreamed of until practically our own day. It is a world so full of threat and promise that hope fights with despair in the minds of men. Some one must think out the solutions of these momentous problems; intelligence is the only possible safeguard against internecine strife. Now the high school occupies a unique position and bears a weighty responsibility, for out of its small selected group must inevita-

bly come in the main such leadership as the future may hope to enjoy. Leadership rests upon two great qualities, spontaneity and initiative, — to the culture of which most of the earlier part of this chapter has been given — and power to think correctly. This is the imperative call for the social studies in the high school, and that in the most practical way. The abstract theory of ethics and economics may well wait for the college and university, but clear and sound notions of certain elements that pervade ordinary adult life, in business, in society, in civic duty, in avocation, should be opened up to every young person in high school. The secondary school is waiting for a Giddings, or a Sumner, with the admirable art of leading the minds of early adolescents into true views of these questions that they must so soon settle at least in practice. What is money? What are labor and capital? What do luxury, waste, unemployment, crime, vice, mean for the lives of men and women and children? Above all, what are the new hopes of our day and generation, the charity that revives the spirit and rehabilitates the will, the physician's art that puts prevention before cure and views its profession as social service; the new patriotism that works in peace as well as war, pays its taxes, casts a well-considered and broad-hearted vote; the new jurisprudence and penology that seek to reform the culprit rather than to avenge the crime. All this is most congenial to the new vocational motive already discussed; the two fields complement each other, the vocation motive reënföring interest in the social studies, and the social ideal illuminating and elevating the vocational concept.

Moral Idealism. — The more distinctly ethical aspect of these social studies is the extension of the radius of altruism in the minds of the adolescent youth. "Who is my neighbor" is the insistent practical question in morals; in the abstract any one agrees that we should love each other, but most of us find that our charity not only begins at home, but never gets far away from its center. The broadening of

knowledge has little value, at least so far as conduct is concerned, unless sympathy also spreads. This is the chief fault with our intellectualized instruction in history, literature, economics, civics, and the like. The true maxim of humanism is the noble dictum, "Nihil humani mihi alienum est," — but things human are apprehended not by the understanding alone, but also by the heart. Humane studies may be quite dehumanized either by intellectual abstraction or by spiritual indifference, and may then become rather immoral by accustoming the youth to look with untouched heart upon ideas and images that ought to arouse the emotions of any true man.

"Unless youth be golden," says Jean Paul, "age will be but dross." There is evidence of the need and approach of a revival of the spiritual element in secondary education, the quality that gave power to the teaching of Arnold and Thring and far-off Vittorino. "Neither young nor old," says President Hall, in his *Educational Problems*, "should lose the ancient vision that has inspired so many of the prophets, saints, and apostles of righteousness, — of some ideal state, commonwealth, or millennium, city or kingdom of God, Utopia, etc., where most ethical characters and organizations are found. In the painful struggle for slight, gradual amelioration of present evils, we should keep some dream chamber in our many mansioned soul, where we can occasionally retire and revel in the imaginations of perfection, and hearten ourselves by yielding to the fancy of all good wishes fulfilled and all high ideals realized."

RELIGION

THE SECULAR SCHOOL. — The outward forms of religion which but recently were a part of all school life have practically passed away from the public high schools of the United States. The great majority of high school students never hear the Bible read nor words of prayer uttered nor any religious instruction or exhortation in school. The history of

this secularization of the school has never been adequately written. It is certainly part and parcel of a sweeping change in the great field of the moral and religious life of our people, and indeed of the whole civilized world. The sanctions of the moral life in the present age are more social than supernatural. The great appeal is to human welfare and hence to social justice. This motive in an extreme form becomes Socialism, which is a religion to most of its adherents.

But while the change is so widespread and pervasive as to be well-nigh universal, it is not certain that it is so profound and fundamental as might be implied by the terms in which it is stated. History, in Goethe's figure, "stands at the roaring loom of time and weaves for God the garment that we see him by." May not social justice and human good also be the visible manifestation of the Divine?

REACTION. — Moreover, there are some signs that opinion is swinging back somewhat from the extreme of secularity. The charge sometimes made by overzealous religionists that the schools are "Godless" has always been warmly resented by most of our people and practically all of the teachers. "Shall we have Godless schools?" asks a metropolitan daily. "Not a family in the community would vote that we should. . . . Who is it objects to the reading of a psalm and the saying of the Lord's prayer? Is it conceivable that the objection which may be expected to so simple a form of religious observance as this shall counterweigh the inculcation of religious reverence? Without regard for creed, there is surely a place for God in the schools to which we send the children."

At least one state has adopted an official syllabus of Bible study for use in its high schools;¹ and requests for the syllabus have come from every state in the union. In one large public high school an elective course in the Old Testament scriptures was given for eight years without arousing the slightest objection and with gratifying results in many ways.²

¹ North Dakota.

² See *School Review*, April, 1913, pp. 246-249.

THE LETTER AND THE SPIRIT. — The greatest danger in the secular school is not the loss of the theological or ecclesiastical content of the traditional religious instruction, but the failure to learn to think of the world religiously, that is, profoundly and humanly. Here is found the justification of the paramount place given to religion in education by educators like Arnold of Rugby, and the Roman Catholics in all periods. True, attention is too often placed upon externalities, — religious exercises, scripture, church attendance, and the like. These externalities are the field of infinite divergence and antagonism, and this has led to the elimination of religion in this sense from the public schools. We are just detecting ourselves in the act of rejecting the essence along with the superficial, or to use the homely German phrase, we are in danger of “throwing out the child with the bath water.”

Hence the first and most general task of the high school, and the secondary teacher, in this respect, is to lead youth not only to think all things in their individual clearness and their immediate relations, — which is science, — but also to get a vision of the wholeness of the world and of life, and the radiations of cause and effect out to their remote bearings in both space and time; and finally to feel that all things get their meaning and value from their relation to the life of mankind, with all its possibilities, both tragic and glorious.

Against such thinking there is no law, nor any voice of protest. Young people of high school age eagerly follow the teacher who leads them in these directions, and cherish the memory of such teachers above all others. But the method is all important: dictation and coercion are worse than useless; learning by rote is futile; here, more than anywhere else, the teacher's rôle is stimulus and guidance; the student must think himself out; the only effective compulsion is the force of truth and reason. But the ancient sage at least had boundless faith in the spiritual efficacy of such a method when he wrote “‘Come let us *reason* together,’ saith the

Lord, ' though your sins be as scarlet, they shall be as white as wool.' ”

MEANS. — Certainly there are means peculiarly fitted to these ends. The Bible will usually be recognized as the supreme expression of the moral and religious life of the past. References made earlier in this section show that the way is probably opening for a renewed attention to the scriptures, at least the Old Testament, in the schools. Natural science no longer boasts of having “ abolished mysteries ” and is in far less sharp antithesis to religious thought than it was twenty-five years ago. History and literature are the great opportunities for nurturing the religious as well as the ethical view of life. I have elsewhere pointed out that many of our heroes, national and universal, if presented truly, bring in religion embodied in their characters and actions.¹

Finally, do we not need to consider earnestly the place which the daily chapel exercise in its various forms held in practically all secondary schools and colleges but a short time ago? Complete return to it is impossible and probably not desirable; but it is hard to doubt that we need to gather students and teachers together more frequently in meetings whose spirit is earnest, reverent, thoughtful, touched with emotion, raised to the higher levels of thought and feelings, in a word, and in the deepest sense of that word, religious.

THE HIGH SCHOOL TEACHER

LIMITATION BY CONDITIONS. — Miss Addams tells of some lads who complained to her that their high school principal never talked to them about life. “ He never asks us what we are going to be; we can't get a word out of him excepting lessons and keeping quiet in the halls.” Yet every one who knows the social status of the school and the teacher knows that the blame for such an attitude

¹ *Religious Education*, April, 1911.

rests upon society and its treatment of the school and the teacher rather than upon the unfortunate high school principal in question, or the thousands of teachers who are like him. The intellectual load of the course of study, tight bound by college entrance requirements, exhausts the powers of attention and effort of most teachers. In the small school the teacher has too many subjects and classes; in the large school too much routine and regulation. The routine must be performed; spiritual influence cannot be placed upon a time schedule nor tested by examination, so we have as of old the tithing of mint and anise and cummin to the exclusion of the weightier matters of the cultivation of judgment and righteousness in the pupils.

REMEDIES. — The amount of potential moral educative energy stored up, or rather choked up, in the high school teachers of the land is beyond computation. Two things are greatly to be desired: first, that the pressure of class work, exercise correction, theme reading, laboratory instruction, and other forms of routine may be greatly reduced, and thus allow the teacher time and spiritual energy for personal relation with classes and individuals; then, also, that teachers should express in word and deed the interest they feel in the real inner state and development of their pupils. The secondary teacher of other days was a teacher of youth; now he is an instructor in mathematics or botany or German; the difference is by no means simply verbal. Admitting, although only for the sake of the argument, that the new instructor accomplishes more in intellectual progress, it may still be asked whether we might not well travel quite halfway toward the older type. After all, the most important of all qualifications for the teacher is that embodied in the vow of the Jesuit, “a special concern for the education of youth.”

Yet must the teacher study to be only a stimulator of the mind and will of the student; moral education consists in

bringing to pass the most and best activity of the will of the educand himself, in all its phases, — energy, intelligent direction, and finally righteousness. He must do right; but the vital doing is inner, psychic, often hidden from all except perhaps the keenest insight. He must think and feel aright; the moral teacher is the one who can accomplish this inner result; and the doing of this is influence. The teacher here as elsewhere is to find his success in rendering himself no longer needed. The road to this end is hard to find; in general it requires that the teacher should do as little as possible and the learner as much as possible. We have suggested that many teachers exercise their powers of moral influence too little — perhaps speak too little with a moral aim; yet it is easy to say too much and do too much. In training as well as in instruction, great is the power of silence and refraining; not seldom it incites the educand to his utmost efforts and so advances him most effectively in power and wisdom. To be ever at hand, ready to help; ever interested in the problems, the perplexities, the temptations, the hopes and ambitions, of the young; yet not to meddle, not to interrupt needlessly, to perceive the right moment and divine the true means, — this is the art of influence.

Perhaps the most practical advice that can be given to the teacher who desires success in this task is to follow the method of the Greeks, who, as Matthew Arnold says, poured a flood of thought about every question. We must think before and after; we must plan our operations as wisely as we can, and subject the outcome to earnest scrutiny that we may do more wisely the next time. Nor is any individual competent to think out his problems unaided; the flood of thought, to be safe and adequate, must come from many minds; hence the value of conference in all its forms, especially, however, among small groups of two or three who have common interests and deal with the same or similar individuals.

The high school youth is looking out eagerly into the world,

— of which he usually takes a very unacademic view. His great problems all look in that direction, as indeed they should. He often views his teachers as semi-clerical, unworldly, almost secluded in their minds and activity. In this he is doubtless partly wrong; but he is also partly right, and the teacher who will seek influence in any high degree with the mass of the youth must live in the current of the world's life, think on the problems of the day, and share in social, civic, and political life. Only thus can he either trust his guidance to be right or hope that his pupils will respond. It is a part of the great price at which influence is bought; fortunately it is also worth while in itself. We may well hope that various present obstacles to such activity on the part of teachers may be removed.

TOPICS FOR FURTHER STUDY

1. How can will power be developed through high school work aside from the training that comes from meeting moral problems?
2. What relation exists between intellectual results and moral training so far as you have observed it in actual schoolroom experience?
3. What changes in our usual high school curricula are demanded to meet this problem of moral education? What changes of method? Of organization?
4. How valuable is "direct" moral training? How can it be given?
5. If the whole problem of education is moral, how can desired moral results be obtained from any one given subject, as mathematics, history, or literature?
6. What is the relation of "interest" to moral education, as you have observed it in your own experience as pupil and teacher?
7. In what respects and why does the period of adolescence seem to be the most fruitful period for moral education?
8. To what extent is it possible to give intellectual instruction through "problems" and how does this affect moral education? What are the difficulties and dangers involved?
9. To what extent should sex hygiene form a part of the instruction in high school? How can it best be given?
10. What value do athletics possess as a means to moral education? What moral problems do athletic activities present to the high school pupil?

11. To what extent can the work in physical education be made the basis of moral training?
12. To what extent can the social activities and organizations of the high school pupils be used as means of moral training?
13. To what extent can forms of self-government be used to effect moral results?
14. Compare either English, French, or German secondary schools with American in the use which they make of athletics, physical education, self-government revenues, direct moral instruction, sex hygiene instruction, or the direct instruction in the intellectual subjects, as means to moral education?
15. In the life and work of great school masters, as Arnold, Thring, Hopkins, was it their influence in moral education or in intellectual instruction that counted more? In each of such cases what were the means by which the moral influence was exerted?
16. Does vocational training simplify or render more complex the problem of moral education? Why and how?
17. To what extent, as shown in concrete studies, does vocational guidance aid in moral education?
18. Does coeducation simplify or make more complex the problem of moral education? In what respects?
19. What place has religious instruction in secondary schools? How can it best be given?
20. What place does religious instruction have in the adolescent period? How can it best be given?
21. What is the relation between religious instruction and moral education?
22. What place and obligation has the teacher in moral education?

REFERENCES

- ADLER, F. *Moral Instruction of Children*. New York, 1898.
- BUTLER, NICHOLAS MURRAY, and others. *Principles of Religious Education*. New York, 1900.
- COE, GEORGE A. *Education in Religion and Morals*. New York, 1904.
- DEWEY, J. *Ethical Principles underlying Education*. Chicago, 1897.
Moral Principles in Education. Boston, 1909.
Interest as Related to Will. Bloomington, Ill., 1896.
- DRAWBRIDGE, C. L. *Religious Education. How to Improve It*. London, 1906.
- First International Moral Education Congress:

(1) *Record of Proceedings*. London, 1908.

(2) *Papers on Moral Education*. London, 1908.

JENKS, J. W. *Life Questions for High School Boys*. Y. W. C. A., 1910.

JONES, HENRY, and others. *The Child and Religion*. New York and London, 1905.

Publications of the Religious Education Association (Chicago) and of the Catholic Educational Association (Columbus).

MCCUNN, J. *The Making of Character*. New York, 1900.

PALMER, G. H. *Ethical and Moral Instruction in Schools*. Boston, 1909. Religious Education Association. *Education and National Character*.

RILEY, A., and others. *The Religious Question in Public Education*. London, 1911.

SADLER, M. E. *Moral Instruction and Training in Schools*. London, 1908.

SPALDING, J. L. *Means and Ends of Education*. Chicago, 1901.

SPILLER, G. *Report on Moral Instruction and on Moral Training*. Bibliography. London, 1909.

SPILLER, G., ed. *Papers on Moral Education*. International Moral Education Congress. London, 1909.

See also the References in the body of this article.

CHAPTER IX

THE VERNACULAR

THE TEACHING OF LITERATURE. — As early as Plato the fundamental theoretical principles which underlie the teaching of literature were already clearly stated. In the *Gorgias* the character who gives the name to this dialogue maintains that he has elaborated an art, the art of rhetoric, which is communicable by teaching and which will assure to the practitioner of that art the greatest possible happiness. Plato, on the other hand, if we may assume that Isocrates expresses Plato's opinions, maintains that what Gorgias calls an art is a false art, is merely flattery (cf. the place which is assigned to the poet in the *Republic*), and that real power has to do only with the perception of and control over that inner truth which is each man's possession in varying degrees by gift of nature, and that consequently there is no communicable art of expression based upon sound moral principles. To these two views, both manifestly presented in the extreme, should be added a third, set forth in the *Ion*. This is the doctrine of "secondary inspiration," according to which certain persons whose spirits are attuned in a peculiar manner to the writings of some specific master of literature are thus enabled to put themselves with respect to these writings into a sympathetic mood of enthusiasm which is similar to the mood of the author in composing them, and which in a certain degree is communicable to others. The three principal points, therefore, which are represented in these two dialogues, expressed in terms of modern thought, are, first, the possibility of teaching the technique of an art of literature; second, the necessity of basing literature not upon technique, but upon personal

character, which is not communicable and consequently not teachable; and third, the transmission of the elements of personal character not completely but in an imperfect manner by means of sympathetic appreciation or secondary inspiration. If we add to these principles a conception not possible in Plato's time, the conception of a history or development of literature, we shall have all the main ideas which underlie the modern teaching of the subject.

ENGLISH LITERATURE IN SECONDARY SCHOOLS.—

The question of the advisability of teaching literature in the modern secondary schools has been definitely answered by actual experience. Through the various stages of the elocutionary speaking of "pieces," the use of reading books, and finally the detailed and formal study of English classics, the study of literature has gradually taken its place in the school curriculum, although it is only within the present generation that extensive and specific provision has been made for such study. The cause and the justification for the contemporary emphasis placed upon the study of the English language and literature are intimately bound up with the democratic tendencies in general of both language and literature within the last three generations. English literature, beginning with the reforms of the late eighteenth and early nineteenth centuries, has become more and more in its modern manifestations an expression of general social ideas and emotions than it has ever been before, and its range of appeal has consequently become wider. Moreover, the modern school, in the extraordinary expansion by which it has assumed to itself many different kinds of activity, left by the earlier school either to the limited instruction of the parent or of special masters, has at the same time assumed certain responsibilities, necessarily arising from the instruction in the elements of these new subjects which the school provides for the public at large. Thus in teaching practically every member of the community how to read and write, the school has placed within the reach of all the elements

necessary to the understanding and the practice of the literary art. Having provided the general public with the key of admission to the treasury of English literature, modern education cannot consistently abandon the public thereafter to its own undisciplined devices. A system of universal popular education logically demands that attention be given to so influential an element as literature in the life of the people; and in answer to this demand, from the lowest grades through the secondary school, the college, and the university, the study of the literature of the vernacular has come to occupy an important, and, on the whole, unquestioned place. The debatable question is no longer whether English literature shall be taught to English students, but how and with what varying degrees of emphasis it shall be taught.

Literary Appreciation. — Perhaps the most important single result of modern practical experience has been the turning aside from matters of information about authors and literature, as exemplified in the old-fashioned manuals of the history of literature, to an attempt at direct appreciation of the literary monuments themselves. It is now generally recognized that historical and biographical information with respect to literature is of secondary value, and that it finds its justification in instruction only when it helps the student to a truer appreciation of the literary product. The study of literature is not, therefore, an appendage to the study of history; and this is especially true in the elementary teaching of literature. The details of historical and biographical information are matters of scholarship, whereas the proper understanding of literature in its simplicity is not primarily a matter of scholarship, but rather of sensibility and feeling.

Study of the Vocabulary. — At the same time it is recognized that the teaching of elementary English literature is not altogether a matter of sensibility and feeling, and that it has elements of a severer intellectual discipline in it. In the first place, all literary expression is made up of words, and an

intelligent understanding of the meanings and connotations of words is absolutely necessary to any adequate appreciation of literary monuments. The teacher, therefore, must gauge the capabilities of students with respect to the vocabulary of the literary expression under examination in such a way as to make sure that their understanding is not only clear, but also in accordance with the normal traditional usages of the language. It is not enough that students should have a definite impression of a work of literature; they must also have correct impressions. In acquiring this right understanding of words, which, as Plato has justly said, is the basis of scholarship, the teacher's most intelligent judgment and oversight are necessary. Obviously the study of a literary monument the expression of which is so far beyond the comprehension of the student that his attention is completely taken up with details, leaving him no energy for the synthesis of his impressions, should be deferred until the student has at his command a wider range both of vocabulary and of modes of thought.

The Literary Language. — Another kind of definite fact which the elementary teacher of literature may not neglect is that which has to do with certain forms of phrasing peculiar to the literary style, especially the use of figurative language. These modes of expression are usually quite outside the student's natural colloquial experience, and unless they are specifically analyzed, the significance of them is not clearly realized, even when the individual words are intelligible. It is the frequent experience of all teachers of English literature that even fairly mature students are unable to see the value of a metaphorical expression, an inability which arises not so much from an inactive intelligence as it does from unfamiliarity with the literary convention contained in the manner of expression. The study of literary style, as it was developed in the early manuals of rhetoric, and as it was based upon the study of the Greek and Latin classics, limited itself almost exclusively to the analysis and classification of figures and

metaphors. The futility of all such classification merely for the sake of classification acknowledged, it must be granted also that, within proper bounds, the analysis of metaphorical expression is justifiable and necessary.

Still a third group of facts to be noted in the disciplinary study of elementary literature consists of allusions, proper names, and other matters of information embodied in the text, the understanding of which is necessary for the proper grasping of the writer's intention. Here again it is apparent that works such as some of the satires of Dryden and Pope, in which the local and contemporary allusions are so numerous as to absorb all the student's attention, are hardly appropriate material for elementary instruction.

The Philological Method. — When stress is placed heavily upon these details of fact, that is, on vocabulary, figures, allusions, etc., the result is what is often called the "philological" method of the study of literature. This kind of literary study, which arose out of a desire to give the study what was considered a disciplinary value, was much more in vogue in a preceding generation than it is at present. The study of figures of speech, for example, was made a very technical drill in the classification of the figures under the heads of an elaborate and pedantic system of classical terminology. In the same way the study of vocabulary was, and often continues to be, carried to extremes in the consideration of the etymological origins of the various words, or their comparative uses by different writers, and similar questions. The study of grammar is often combined with the study of literature, and teachers have been known to compel students to parse through every word of *In Memoriam* under the pretense of a literary study of that poem. It is perhaps sufficient to point out here that the philological method when carried to such extremes does not answer the requirements of the study of literature, however valuable it may be as a technical drill in language. The common-sense conclusion seems to be that a piece of literature

should not be taken up, at least in elementary or secondary instruction, when it requires such elaborate linguistic commentary that the student's attention and energy are completely abstracted from the appreciation and enjoyment of the work merely as literature.

Technique and Structure. — The more subtle questions of technique, such as those which have to do with form or structure in the larger sense, the differentiation of types, the conventions of individual types, etc., are usually, and may very well be, disregarded in elementary instruction. With the most mature students the interest of these questions with respect to literature may be considered as esoteric, and with younger students, much more limited in power of abstract thought, the dwelling upon them is merely confusing. There is perhaps somewhat more justification in dwelling upon historical considerations, *e.g.* the period at which a work was written and the particular contemporary circumstances of its composition. Such details are often helpful in grasping the meaning of a work as a whole. But it is doubtful if students should be much troubled with attempts to group writers into periods, or to appreciate large general movements, like classicism and romanticism, in the earlier stages of their literary training. The usual plan of reserving such considerations for the last year of the secondary curriculum or for the college seems to be the wisest.

As to the question of transmitting appreciation for the literary monument itself, after all matters of technical detail have been disposed of, apparently little that is of practical value can be said. It will be generally conceded that Plato was right when he declared that there was no communicable technique for the best aspects of literature, and that a right feeling, "a secondary inspiration," will accomplish more than the most ingenious technical analysis. And as the Greek rhapsodists gave expression to this secondary inspiration mainly by reciting the works of the authors who inspired

them, so in elementary instruction intelligent reading is often more effective than elaborate commentary.

Moral and Cultural Value. — One other aspect of the elementary study of literature presents itself insistently to the teacher, and this is the question of the relation of the study of literature to the study of morals, ideas, and civilization in general. It is obvious that the possibilities of correlations of this kind in literary study are almost illimitable in extent. No other kind of expression has summed up so directly and so compactly as English literature has done the ideas and forces which have exerted influence upon the thought of the English people. Any adequate study of the monuments of English literature must consequently and of necessity lead over into a consideration of moral ideas. The study of *The Merchant of Venice*, of *Silas Marner*, of *The Ancient Mariner*, to choose a few examples at random, inevitably raises in each instance important questions of moral conduct which are inherent in the very conception of the works. The endeavor to exclude such discussions by limiting the choice of texts read to simple narrative, like Scott's narrative poems, seems hardly defensible, since it excludes what must be regarded as the most characteristic products of English literature. Here again a balanced and common-sense attitude toward the question of moral instruction in the teaching of literature seems to be the only one tenable. To make literature merely the vehicle for the conveyance of moral instruction, to torture a moral lesson out of every innocent poem or tale, changes the subject from the study of literature to the study of ethics, besides frequently destroying for the student the characteristic charm of the writings under consideration. On the other hand, the moral and didactic implications of many of the most important monuments of English literature cannot be disregarded without slighting what is after all one of the most persistent and prominent characteristics of the whole history of that literature.

Grading the Material. — The question of grading the material used in literary study may naturally be answered variously according to the attendant circumstances. In general, however, in the early years of the elementary pupil's development, the most appropriate material will be found in fairy tales, folk tales, myths, and simplified forms of epic narrative. The next stage in the development of popular narrative, and the one which is most appropriate for study in the later years of the elementary school, is represented by the romantic tales of chivalry, such as the stories of King Arthur and other medieval romances, as well as chivalric stories from actual history. In the secondary school, on the other hand, considerably more attention is paid, and appropriately so, to writings which are specifically works of literary art, and which consequently bear the marks of conscious literary artifice, such, for example, as the list of "English Classics" prescribed for reading and study in preparation for entrance into college, and the still larger list now recommended for all secondary schools by the National Council of Teachers of English.

THE TEACHER AS AN INTERPRETER OF LITERATURE. — The "interpretation of literature" is a general expression including one or more of several things. In its primary and simple sense, it means understanding what the author has said. Such interpretation is the main thing in reading simple straightforward prose like Lincoln's *Gettysburg Speech* or Macaulay's *Life of Johnson*, and simple poetry like Longfellow's *The Wreck of the Hesperus* or Homer's *Odyssey*. It is in this primary sense that the child reads his *Second Reader*, and the average man reads his daily newspaper. He gets the surface meaning, interpreted and made significant by such experiences as he has had. But what the classical scholar gets in reading Homer differs widely in quality and quantity from what the schoolboy gets; what the statesman or historian understands and sees in the daily news differs from the read-

ing of the ordinary citizen; *The Pilgrim's Progress* had more meaning for the Puritan theologians than it has for a twentieth-century reader. It is obvious that even in the reading of the clearest, simplest literature there are widely varying degrees of understanding and mental responsiveness. It is equally obvious that as the education of the child progresses he ought year by year to be able to get more out of the simpler forms of literature, and to read literature whose comprehension requires more accumulated experience from both life and books; the general field of literature ought for him to have year by year more and deeper significance. As his power of interpretation grows with his general mental growth, he will naturally put away some of the childish things. It is no disparagement of the nursery rhymes and folk-tales that the high school pupil has outgrown them; no disparagement of Longfellow that he has little to say to highly cultivated minds, though he may have been among the favorite authors of their nonage.

Interpretation is, then, a changing and growing, not a static, power in all who are in process of being educated. It is primarily a matter of comprehension. It is closely related also to taste, has much to do with forming and determining taste; for how one feels towards a subject is determined largely by how much one understands. Is the town drunkard a joke, or an object of pity? Is the financial bandit to be envied or to be despised? Was Napoleon a great man, or a powerful brute? Is war glorious, or senseless and bestial? Are the footlights of the cheap theater the entrance to fairyland? Your answer to such questions will indicate not only your feelings, but what you really *know*. And so with books. Is Dickens sometimes vulgar or maudlin? Does he rank high in fertility of invention? Is Omar Khayyam irreligious? Is the newspaper you read conducted with intelligence and honesty? Do you accept the statements of advertisers or politicians at their face value? A book, like a fact, is nothing

in itself. Unread, it is non-existent. Read by one person, it is one thing; by another person, another thing; to the same person at different times, even, a book may have widely different values. Different ages, as well as different persons, have viewed differently the same books. Shakespeare intended his audience to jeer at Shylock in his defeat, and they did; but modern readers, actors, and audiences find him a tragic figure in spite of Shakespeare's clear intention, and Portia's mercy speech rings hollow if not hypocritical. Don Quixote was a humorous scarecrow to the seventeenth century, an object of sympathy and admiration to the nineteenth. The interpretation of literature is, indeed, a highly relative thing: changeable, various, and complex. And the teacher must not expect a book to have the same import and value for all his pupils.

The student of literature, that is, the thoughtful reader of literature, may approach it from different directions. These approaches may be determined by our own dominant interests or by the nature of the literature itself.

1. Our interests may be largely linguistic. We may study our Shakespeare, our Chaucer, our Alfred, for the language of the time. This is an interesting and important study, but it is not, strictly speaking, the study of literature. It is the study of that in which literature is expressed, and without which it cannot be understood. The authors and scholars of the eighteenth century, being ignorant of Middle English, were under the delusion that Chaucer was barbarous and unmusical, and so failed to enjoy the charm of his poetry. English philology has put Chaucer back among the readable poets. Most of the failure of high school pupils and ordinary readers to appreciate Shakespeare is due to the strangeness of his language; he was clear enough to the audiences of his own day.

To slight the study of words in teaching literature is to render the reading weak and colorless. Not only the mean-

ing, but the quality and flavor, of a selection are determined by the fine shades of diction. He only has learned to read who has become sensitive to words, and is willing to give careful thought to their meaning. Such a reader will find his range widened, not only in English, but in its related dialects. Burns and Scott among the elder, and Barrie among the later, writers demand an eye and ear quick to take in dialect. Tales of Irish life, stories in negro dialect, like Uncle Remus, and many other variations from standard English may be read not only with pleasure but in confidence that they are literature. The genius of the English-speaking peoples is hospitable to new and changing forms of speech, averse to fixity and to linguistic authority.

2. Our interest may be biographical, not in the narrow sense of the external facts of the author's life, — those events that can be recorded with dates affixed, — but in the fuller sense of an interest in the personality of the man. Much so-called biography is only remote gossip; not wholly unworthy and ignoble, if taken as an interesting and significant part of the great human document. One would not like to be ignorant of the fact that the great have had their sins and foibles; but one would hardly wish to have such things loom so large as to impair one's sense of values. Yet, in studying literature those features of an author's life and character which help us to understand his work are well worth while. The connection between one man's life and his books will not be the same as another's. Burns, Lamb, Goldsmith, Stevenson, have written themselves into their work in a full and direct fashion. Milton and Tennyson have done it much less directly. For such of his life as we have, Shakespeare has done it still less; and it is hard to see, in these last three instances, how the study of their lives can throw much light upon, or create much interest in, their work for young students. Indeed, it is rather common among lovers of literature for their interest in literary biographies to come late, — say at twenty-five or later, — though

their familiarity with good literature may date from their early 'teens.

When one has reached the point of finding the author's personality in his work, he has come to the thing of value in the biographical aspect of his studies. How a flower, or a waterfall, or a peasant appealed to Wordsworth, to Burns, to Scott, to Tennyson; how Shelley reacted to a social wrong, how Burns did, how Dickens did; what things were humorous to Chaucer, to Shakespeare, to Jane Austen; what things roused Milton's anger, and what his reverence; which authors see life direct, and which see it through the medium of books; what things appeal to the senses of this man or that,—these are not biographical questions only, but critical, also, and are therefore interpretation of literature in a very real sense.

3. Our interest may be historical. We may view a piece of literature as a link in the chain of historic development. The rise and end of the epic; the invention of the sonnet, its disuse and subsequent revival; the rise and decline of the heroic couplet; the development of the various forms of the novel, in the guise of letters, or of autobiography or of the omniscient third personal narrator,—these and many other matters of form invite historical study. More interesting than these matters of form, however, is the development of ideas. The sonnet has enlarged its scope from a simple, usually trivial, love motive, until it includes almost every phase of human experience capable of brief poetic expression. Ideals and standards of taste and morality have changed immensely. Some of the tricks played upon foolish Malvolio strike a modern audience as brutal rather than funny; and so the prison scene is now omitted from stage representations of *Twelfth Night*. Milton's ideas of woman's place are not the same as those in Tennyson's *The Princess*. Chaucer's *Wife of Bath* had a freedom of speech repugnant to the taste of the nineteenth century, but our own time seems disposed to allow her modern counterparts an equal degree of freedom in

the name of the social sciences. The bludgeon-like insults of the eighteenth century, in epigram or heroic couplet, once passed for wit and satire; now they would only serve to mark the author as socially "impossible." Since Wordsworth's day the humble and the poor and the child have come to a place in literature undreamed of in Shakespeare's day.

Such changes in literature both record and cause the changes in social ideals, and are therefore not only profoundly interesting, but, as subjects of study, immensely valuable. The student who has begun to notice such things, to compare ideals in different times and different authors, has begun not only to read, but to learn and to think; he has awakened to what is perhaps the greatest educational force in literature. To cite a familiar instance: When George Eliot closes her village idyll of *Silas Marner* by marrying her heroine to a common village laborer, instead of letting her enter into the inheritance and the opportunities which her father, the squire, offers her, we note the unconventional nature of the *dénouement*. Why has the author done this? Out of regard for young Aaron, the rustic lover? Hardly, for he need not even have been introduced into the story. To punish the father for his cowardly delay in acknowledging his child? But he has already been punished in various ways: he is childless, he has his conscience and a gently censorious wife. Is this the only way of rewarding Silas? He could die in peace and happiness before the necessity for Eppie's choice arises. Does the author mean that there is more happiness in a cottage than in a mansion? Is it the spirit of nineteenth century democracy, or her strong sense of the laws of things, that guides the author to this ending? Whatever answer we make, we are forced to admit that the story would probably not have been ended thus before the days of George Eliot. Any one of a dozen authors of the nineteenth century might have ended the story as she did, but hardly one of those of an earlier century.

4. Our interest may be purely æsthetic. In much of our reading we are content with the satisfaction of our æsthetic sense. We find the story or poem is beautiful, and ask no more of it. Such is the appeal of many lyrics, for example. The songs of the sixteenth and seventeenth centuries, the comedies of Shakespeare, the odes of Keats and Shelley, the poetry of Swinburne, often raise little thought, or none, as to their meaning, their wisdom. They have no "message," no evangel, for us. It may be beauty of sound that we feel, ranging all the way from the simple rhythm of Mother Goose to the intricate melody of Swinburne or the "organ-music" of Milton. It may be the beauty of the picture presented, as in Keats' *Eve of St. Agnes*. It may be the vague stirring of other æsthetic memories, as in Keats' *Nightingale* or Wordsworth's *Highland Girl*. Often, indeed, the pleasure is in a thrill, a transport, compounded of several of these elements. To those for whom such things have no appeal, they have no appeal. The deaf cannot enjoy music, the blind do not frequent picture-galleries; but deafness and blindness are misfortunes, not arguments.

5. Our interest may be in the form and structure of a piece of literature. We may examine the meter and rhyme arrangement of poetry, study and compare the various types of sonnet structure, note the parts of a short story, trace the threads of action in the complicated plot of a novel, follow the development of a drama through the crisis to the *dénouement*, or note the logical relation in the parts of an essay. Such study, especially in the drama and prose fiction, involves important acts of judgment, where plot is made to depend on probability in action or consistency in character. That story is convincing which seems to unfold naturally and inevitably from given conditions. Where probability is strained or character forced, the story weakens. The effect of a drama or story depends much upon the arrangement of climaxes, suspense, and expositions. The study of these things demands inter-

esting acts of judgment. And when we seek to determine the fitness of a verse-form to the idea expressed in it, both judgment and taste are involved.

It is easy and tempting to overdo this form of study. Its definiteness is attractive, like the definiteness of mathematics or formal grammar. But it is to be remembered that literature is complicated, as mathematics and grammar are not, with quite other elements that do not lend themselves to exact formulation. Emotion and taste are complex, often nebulous, and must not be dissipated in a mistaken effort for exactness and formality.

The kinds of study sketched in the foregoing paragraphs will not answer the question how a given selection is to be read. Generally it should be from several of these points of view. The treatment appropriate to one piece of literature is unsuited to another; the presentation of the same piece of literature will quite properly differ for different classes, or for the same class in the hands of different teachers. No teaching in the secondary school should or could exhaust all these types of study. Any method which reduces the teaching of the classics to rule and formula is pretty certain to become inflexible, unsympathetic, wooden, because it loses sight, first, of the relative interest and values of things in any particular piece of literature, and, second, of the things that can appeal most to the given class. The attitude of the teacher should be that of a cultivated mind ready to help his pupils see and appreciate those things which at their stage they can best see and those things from which they can get most of information, wisdom, and æsthetic satisfaction.

As to method, little need be said. It will, of course, be no stereotyped method that will get good results. Relevant information, sometimes got from suggested reading, sometimes imparted *viva voce* (even brief lectures are not always bad); questions that hint at and open up new ideas; tests of memory; reading aloud, not too much, even though the teacher does

think he reads well; enthusiastic emphasis upon the really significant and beautiful things; some analysis — again not too much — upon what gives the beauty and significance; and a large catholicity of taste regarding both literature and life, — these are some of the elements that make for good method in teaching literature.

A few instances of this informal treatment of literature may make for greater clearness. Hawthorne's *David Swan* is one of the simplest stories in his *Twice-told Tales*. The author announces his theme at the beginning: Events big with possibilities often brush near us and pass us by without our knowledge. How does Hawthorne illustrate this? Three possibilities, wealth, love, and death, or what might have led to each of these, almost come to David while he sleeps by the roadside. In the same book, in the story of Dr. Heidegger's Experiment, Hawthorne gives his answer to the question, Could we live our lives over again, should we live more wisely? He chooses for the experiment four old people whose lives had been such conspicuous failures that they might well wish for another chance. They are given the magical water from the Fountain of Youth; they drink, find their youth restored, and forthwith proceed to indulge in the same kinds of folly as had originally wrecked them. In the climax of their revels they upset the water, and old age descends upon them again. How has Hawthorne prepared for this introduction of the magical? By a certain uncanny gloom and by hints of magical things in the doctor's office. How does he bring the scene to an end? By the breaking of the bowl that contains the water. His use of the mirror, his moralizing, have his characteristic imaginative and speculative touch.

Browning's *Up at a Villa — Down in the City* introduces a lively and volatile Italian who would like to live in the city, but cannot afford to do so. How do we know he is volatile? What pleasures of city life does he wish for? The processions, the noises, the gossip, — the things that to him mean life.

Why is the city too expensive? We need to know about the heavy taxes imposed on food in Italian cities. What lines or phrases indicate these things?

But bless you, it's dear, — it's dear! fowls, wine, at double the rate.

They have clapped a new tax upon salt, and what oil pays passing the gate,
It's a horror to think of.

His delight in noise is as naïve as that of a boy at the circus:

Bang — whang — whang goes the drum, *tootle-te-tootle* the fife:

No keeping one's haunches still: it's the greatest pleasure in life.

Ere you open your eyes in the city, the blessed church bells begin:

No sooner the bells leave off than the diligence rattles in.

What, by the way, is "the diligence?" And what is the "Pulcinello-trumpet" mentioned a few lines farther on? And the "traveling doctor" who "gives pills, lets blood, draws teeth": has — his kind disappeared? And the church ceremonies, in church and on the street, — have you seen any of them? Does our Italian who says, "I scratch my own (skull), sometimes, to see if the hair's turned wool," pay any unconscious tribute to the beauty of the country?

You've the brown ploughed land before, where the oxen steam and wheeze,

And the hills oversmoked behind by the faint gray olive-trees.

* * * * *

'Mid the sharp, short emerald wheat, scarce risen three fingers well,

The wild tulip, at end of its tube, blows out its great red bell
Like a thin clear bubble of blood, for the children to pick and sell.

Is Browning merely laughing at our childlike friend of the poem? Or does he have a kindly, smiling sympathy for him? And is the man in the poem like the mass of the dwellers in cities to-day? Is Browning preaching a lesson, or merely showing us a type? Do the lively meter and the free and easy colloquial diction fit the speaker and express him well?

But there is no end to illustrations that might be used, and, as I have already insisted, there is no set form that holds for all selections or for the second time in the same selection.

COMPOSITION. — The term “composition” is applied to the grouping of figures or other objects in painting and sculpture, and to the grouping of ideas in language. In each case the end sought by such grouping is the attainment of certain general effects in the whole work. It is of the grouping of ideas expressed in words that this article treats.

Though the terms “rhetoric” and “composition” are frequently found together, and sometimes confused, they properly designate two quite distinct phases of the subject. Rhetoric is concerned with the theoretical side, with the laws of expression. The term “composition” means (1) the application of those laws, consciously or unconsciously, in spoken or written discourse, or (2) the discourse itself. A treatise on rhetoric is a systematic presentation of the laws of discourse, generally illustrated by specimens of such discourse. Composition, being the application of these laws, is therefore an art, as distinguished from a science. It is, moreover, an art that is in constant employment by all normal people, in either its spoken or written form; though the difference is very great in the skill with which the art is practiced by different people.

The four fundamental processes of composition are distinguished by the ends they have in view: narration, which aims at telling a story, or a succession of incidents; description, which aims to describe or portray, and which most commonly makes its appeal to the visual imagination; exposition,

whose purpose is to explain ; and argument, whose purpose is to prove some proposition. While the distinctions among these forms are often convenient in instruction, it must be remembered that the various forms are seldom found entirely distinct. Narration and description are often found in the same composition. Moreover, the methods of the two are often so closely alike that it is difficult to say of certain passages to which of the two processes they belong. Exposition and argument are often found together, though the line between them is easy to draw. But exposition and description again often overlap each other. The full treatment of them belongs to the theory of rhetoric rather than to the art of composition, and finds no place either in the modern textbook of composition or in the work of the teacher. Of these four processes exposition is by far the most common both in written and in spoken language ; narration comes next in order of frequency. Except in literary works, descriptions are usually limited to a few words. Except in formal presentations of propositions in law, science, or the like, arguments seldom proceed beyond a few sentences.

Composition looks rather to the end to be attained, *i.e.* the effect to be produced, than to the employment or the practice of any one of these type forms of writing, though the laws of each must often be consciously used by the writer. In scientific exposition or in serious argument, however, it is necessary to adhere more closely to the type.

The Teaching of Composition. — Within the past twenty-five years the art of composition has assumed far greater importance in the schools than ever before. So long as the ideals of classical study ruled the schools, and culture was thought to come principally from a knowledge of Greek and Latin, expression in English was neglected by teachers. With the breaking away from the classical tradition, and the increased recognition of the educational value in the study of modern life and environment, the minds of teachers turned more and

more toward instruction in the mother tongue. The beginnings of the movement go back, indeed, to the days of Franklin and Jefferson. But the general movement even in some of the less backward schools cannot be said to have become established before 1885. It is now usual to find composition given a large share of the time of the program, and taught as a vital subject rather than in the occasional and perfunctory fashion of former days. It is now recognized as a subject of the greatest utility, inasmuch as every one depends for his pleasure and success in part upon his ability to express his ideas agreeably and effectively. It conduces to clearness and definiteness in one's thoughts, to care in ordering and expressing them. To have tried conscientiously to say things well helps in the appreciation of things well said, and therefore adds to the enjoyment of literature. And command of one's native speech puts one into closer touch with the social and national life about him. Such are the principal arguments by which the present important place of composition is defended.

Especially noteworthy are the changes in the methods of instruction. Theory has given place to practice; it is fully realized that one can learn to speak and write only by speaking and writing under stimulus and guidance. Rhetorical rules are worth nothing except as applied. The earlier teaching aimed at a sort of lifeless accuracy. Verbal and grammatical correctness, propriety in spelling and punctuation, were sufficient. The present-day teaching of the better sort judges the child's efforts not only for these things, but for the interest and general effectiveness of the whole composition. Has he done with the subject what he should have been expected to do? Does his composition show that he has remembered and thought; that he has ordered and arranged? Such is the standard now set up, adapted though it must be to the child's age and capacity. In accordance with these standards the training is not in the lesser units of words and sentences so much as in paragraphs and whole compositions.

Through the influence of modern linguistic scholarship another influence is slowly working its way into the schools. Under the older—and erroneous—conception of language as a fixed and absolute thing, teachers often set up a rigid standard of grammatical and rhetorical propriety that could not be justified either from literature or from the speech of a large body of educated people. This standard, under which most teachers of the present day were educated, is slowly giving way before the conviction that a considerable latitude must be allowed in the choice of words and expressions; the conviction that it is often impossible to say, as between two expressions, that one is right and the other is wrong.

More and more the tendency is to have the pupil write of the familiar and concrete, of the things within his own daily experience, instead of the abstract and remote. It is realized that he can learn to write and speak best when dealing with simple and familiar things. Such material commonly includes also his school work in other subjects than English. Themes drawn from his readings in literature may well be included, but must be chosen with careful reference to the limitations of children's minds.

Composition is recognized as a difficult art, involving, as it does, not only the expression of ideas, but the gathering and arrangement of them. So far as possible these two tasks should be divided. When the subject is chosen, it should be worked over and discussed in various lights, until the pupils can talk of it with some degree of freedom. The writing should be begun only after the pupils have gained some confidence in their ability to talk of the subject, and, in the later years, are able to outline it with a fair degree of clearness. Outlines made by the pupils themselves are an aid to both confidence and clear thinking.

In the elementary school the work in composition may be easily carried into other school studies, inasmuch as they are usually all taught by the same teacher. In the high school,

however, the divorce between English composition and other subjects is an evidence that our systems are still imperfect. As long as the pupil speaks and writes carelessly in other departments, so long will the work of the English teacher fail to form good habits. Not until all teachers coöperate can we hope for the best results attainable.

As to the time of beginning the training in composition, and as to the amount to be required, there is still considerable divergence both in theory and practice. As to the question of how much writing should be employed there are again differences of opinion. In general, however, it is agreed (1) that short exercises are better than long, for the long ones tend to produce either discouragement or prolixity; (2) that some writing should be done every day, the subject often being drawn from some of the school studies; and (3) that, if consistent with the foregoing rule, the pupils should not write more than the teacher has time to read.

This leads naturally to the question of criticizing the pupils' efforts in expression. The oral work should be carefully watched. Errors and carelessness alike should be corrected, generally when made, except when such interruption interferes with the pupil's thinking. The criticism of the written work is the only means of insuring its effectiveness. A few general principles, now commonly accepted, may be stated. Pupils are to be made as much as possible self-critical and self-helpful, though care must be taken not to develop their self-criticism to the point of inhibition. They must be held responsible for things once learned. Generally the written work, after the teacher has corrected it, should be returned to them, be worked over by them, and again submitted for inspection; for if the criticisms made are not applied, they are useless. Work obviously careless in form and matter should not be accepted, if the teacher would have the pupils respect and value the subject. But the criticism must not stop with these more mechanical matters. The work must be judged for its

ideas. And, speaking relatively, the pupil must be led gradually to value his and other work for the ideas he has got into or from it, as well as for the clearness and effectiveness with which the ideas are conveyed. For this there is no better means than reading the compositions aloud, having the class as a whole help in passing judgment upon each other's performances. In all the work of criticism the teacher's true function is not that of the faultfinder, but of the stimulating and helpful guide. If freedom and accuracy are to be attained, there must be a certain amount of drill. Frequent practice in dictation will help in giving control and facility over the forms of words and sentences. Of considerable value also is practice in saying the same thing in different ways. In brief, the work will be effective in proportion to the teacher's skill and resourcefulness.

The prominence given to the work in composition in recent years is due in part to the demands of the colleges that their students must, at entrance, give evidence of a good course in English, and in a greater degree to the belief, on the part of the high school teachers themselves, in the value of such instruction. It is especially to be noted that those high school courses which are not directly preparatory to college commonly give more time to instruction in English than is contained in the college preparatory courses. For a considerable period the desire to unify the course in English, and especially the literature and composition, led to forced relations that were not to the advantage of either. Pupils were required to write too frequently on literary subjects that were beyond their grasp, with the result that the compositions were insincere and futile, and the pupils' love of literature was hindered rather than helped. At the last meeting of the national conference on college entrance requirements in English (1912), in which both colleges and high schools were fully represented, a report was adopted which, it is hoped, will tend to put the composition work on a sounder basis. One of its most important recom-

mentations was that a considerable part of the composition writing should be upon such experiences as come within the pupil's daily life and observation. That the report was in harmony with the judgment of the best teachers appeared from the way in which it was received.

TRAINING IN ORAL SPEECH.—In American schools the late eighteenth century and the early nineteenth gave renewed emphasis to the importance of declamation through the increased opportunity for the public oration and the numerous occasions for display of oratorical power. The textbooks in reading and literature, as well as even those in spelling and grammar, became filled with selections suitable for declamation. This replacing of the old reading materials, chiefly of a religious character, by those of a political, social, or dramatic character, had great influence on the interests and the character of the people. Reading and such literary studies as found a place in the schools came to be used chiefly to develop this power of public presentation, rather than to develop literary appreciation, or power to use the English language effectively in conversation, speech, or composition. It was customary, in most schools, to set aside one afternoon a week, or at least one afternoon a month, for a general assembly to be devoted entirely to declamation. These exercises seem to have had a marked effect upon the public speaking of the period, but an effect that hardly meets with modern approval. In general the selections were beyond the comprehension of the pupils or of but little interest to them. They were usually martial verses on the order of *Bernardo del Carpio* and *Horatius at the Bridge*, or the fervid perorations of an impassioned oration, such as Patrick Henry's *Appeal to Arms*. Furthermore, these declamations were mechanically delivered in imitation of the pattern set by the teacher, and unlucky was the pupil who misplaced a gesture or failed to inflect his voice in the exact manner which his model indicated. The style developed, not only in the pupils but in adult speakers, was

bombastic and flamboyant — the style that even now appeals to the untutored as the very acme of oratorical perfection. When we hear it said that oratory or declamation is now on the decline, we must surmise that the reference is to this kind of oratory — the spread-eagle, star-reaching pyrotechnics of our forefathers.

But declamation and oratory in the truest sense are not declining, but rather developing; more refined standards are replacing the coarse ones of half a century ago, and sounder pedagogical principles are followed in the use of declamations in the schools and in the methods employed in teaching them. More time is now given to English than to any other subject, and also the child's power of free, oral expression is developed as the foundation for all effective work in reading and composition. In company with conversation lessons, language instruction, reproduction of stories, and dramatization, the memory or primary declamation helps to develop this general power of effective oral delivery. If well chosen, these memory selections are within the child's comprehension, are of interest to him in their subject matter, and have a distinct literary excellence calculated to develop taste. The purpose of classroom and assembly recitation of these selections is not only to secure confidence before an audience, but to give a power of literary appreciation and a consequent ability to render the thoughts of the author in a sympathetic manner. The teacher also makes use of the declamations as a basis for the correction of defects in pronunciation and articulation. As a rule, very little is done in the matter of voice training and technical elocution. In teaching these selections, the methods generally adopted are calculated to increase the child's knowledge of words, impress him with a love for the beautiful in literary composition, and develop his general power of correct and pleasing oral expression, rather than to prepare him definitely for public speaking. But as the work progresses, this function of the declamation as a training in general

language excellence gives way to a more distinctly oratorical purpose. The declamation is used more and more as a convenient means of having a pupil speak in public at a time when he cannot be expected to say something original.

The separation of elocution from the general training in English becomes clearly noticeable in the secondary schools. In many city high schools and private academies the work of elocution is in the hands of a specialist, and is not regarded as a by-product of the department of English language and literature. The differences between the structure of matter meant to be spoken and that designed to be read are pointed out, and the pupil is trained to have a definite attitude toward the audience. In the treatment of declamation, the method is distinctly modern. Whereas a few decades ago the pupil was carefully coached to imitate his master's way of rendering a selection, the plan now is to stimulate rather the pupil's self-activity and to expect a spontaneous rendition of the declamation, prompted by the pupil's own thoughts and feelings. It is customary for the pupil to analyze the piece carefully for its meaning and to give the teacher either an oral or written paraphrase as evidence of the thought he gets from the author. The teacher guides, suggests, and keeps up the interest, but seldom recites any passage, for he is seeking, not to impose his own personality and mode of expression upon the pupil, but to bring out a sympathetic rendition of an intelligent, first-hand interpretation. The pupil is made to realize that he must faithfully represent to an audience, by his voice and gestures, the thoughts of another. He owes a duty to the author and to his hearers. The selection is a living message to be conveyed to others, not a "piece" to be memorized and mechanically ground out in close imitation of the teacher. During the practice with declamations, instruction is usually given in the elementary principles of elocution, orthoëpy, and voice management; and practical efforts are made to correct defects of delivery ranging all the way from stammering and

stuttering, through nasality and dialect, to mere localism and mispronunciation. In some schools, where debate and extemporaneous speaking are taken up, the declamation is regarded as a preparation for these more original forms of public speaking.

COLLEGE ENTRANCE REQUIREMENTS IN ENGLISH. — Since 1885 the preparation for college in English has evoked more discussion than any other preparatory subject. Its prominence is, however, comparatively recent. Long after the admission requirements in Latin, Greek, and mathematics were definite in form and respectable in amount, English as an entrance subject was not mentioned. About the beginning of the nineteenth century there were some slight beginnings. Nothing appeared, however, in the direction of the present full view of English as a preparatory subject, until Harvard, in 1874, required both literature and composition. This requirement was the germ of the present system. "Each candidate," said the Harvard announcement, "will be required to write a short English composition correct in spelling, punctuation, grammar, and expression, the subject to be taken from such works of standard authors as shall be announced from time to time. The subject for 1874 will be taken from one of the following works: Shakespeare's *Tempest*, *Julius Cæsar*, *The Merchant of Venice*; Goldsmith's *Vicar of Wakefield*; Scott's *Ivanhoe* and *Lay of the Last Minstrel*." This plan, with various modifications, was adopted by other colleges: by Michigan in 1878, by Cornell in 1883, by Princeton in 1885, by Columbia in 1891, and by Yale in 1894. By 1897 as many as eighty of the leading colleges had adopted the general plan. Some of the colleges examined on only a single author, as Cooper, Irving, or Goldsmith. But gradually the list grew, until, by 1895, ten or twelve books were required by many of the colleges in place of the half dozen of the earlier requirement. There was still, however, great diversity, not only in the books required by the various colleges, but also

in the nature of the examinations. As a result, in a subject at best so indefinite as English, the fitting schools found their task seriously complicated. Various attempts were made to unify and standardize the requirements. The first were by the New England Commission of Colleges in 1885, and by the Association of Colleges and Preparatory Schools of the Middle States and Maryland in 1887. In 1894 the recommendations of these two associations were brought together and a revised list of books was agreed upon by both, and adopted. This list was accepted also by the Association of Southern Colleges and Preparatory Schools and by the North Central Association. The Committee of Ten appointed in 1892 by the National Education Association, to inquire into the whole matter of secondary curricula, gave especial attention to the unification of the English requirements, and also to the formulation of a course of study and of the principles which should govern instruction in English.

Since 1895 the modification of the requirements has been in the hands of a National Conference on College Entrance Requirements in English. This conference is a joint committee composed of delegates from the college and preparatory school associations mentioned above, and also from the New England Association of Colleges and Preparatory Schools, and the College Entrance Examination Board (*q.v.*). The reports of this committee, which meets at least every three years, are referred to their respective associations for adoption. In one of its meetings (1897) it was agreed that the English course in the high schools should be the same for the students who were not going to college as for those who were. In this and succeeding meetings of the conference, the courses of study were framed by the conference with this principle in view. Partly as a matter of convenience, and partly in acceptance of this view, the high schools pretty generally adopted the recommendations of the conference; which thus came to set the norm or standard for most of the secondary

instruction in English throughout the country. The recommendations, though frequently modified in the light of experience, have not been universally satisfactory at any time, and are not so at present. It has been impossible to meet the special needs of all pupils and the special tastes and judgments of all teachers. But, none the less, the work outlined in these reports is substantially the course of study followed in almost all the good high schools and fitting schools of the country, and is the basis of the entrance examinations in practically all of the good colleges which admit either upon examination or by certificate. In order to meet the needs of schools which do not prepare students for college, there has been recently formed (1912) a larger and more representative body, called the National Council of Teachers of English, under the general auspices of the National Education Association. Its official organ is *The English Journal*. The recommendations of this council as to the course of study in English in the high schools are accepted by most of the colleges, and are coming to set the norm especially for non-preparatory high schools.

The most prominent changes in the recent recommendations of the conference have been (1) in the direction of emphasizing non-literary themes as subjects for composition, and (2) in enlarging the list of books from which choices may be made. In 1905 the conference, in response to a general and insistent demand for "more freedom," enlarged the list of books "for reading" from a list of ten required to a list of forty out of which ten were to be chosen. In 1908 and 1909 the list was still further enlarged. The report of the last conferences, held February and May, 1912, and making recommendations for the next three years, indicates the present status of the subjects. The list of books from which choices may be made now includes several hundred titles, the greater number of them in the field of fiction. The list is still deficient on the side of informational and scientific works.

TOPICS FOR FURTHER STUDY

1. What books in the high school course in English have the ethical as a dominant interest?

2. What books have instruction as their main interest?

3. What books or poems are wholly æsthetic in their appeal?

4. What background of general knowledge — historical, scientific, or social — should teacher and pupils have for appreciating books like the following: *Silas Marner*, *Ivanhoe*, *The Tale of Two Cities* (see Chap. XIV of Coleridge's *Biographia Literaria*), *The Lady of the Lake*, *Henry Esmond*, etc.

Is much of such background needed to understand the book?

5. Make out a list of reading which the teacher should have done before teaching some one of these books.

6. What kind of "philosophical" study is needed to appreciate Shakespeare?

7. In view of the fact that Shakespeare's plays were written to be acted, how should they be read in school? How much place should be given to the so-called "philosophical" interpretation of them?

8. What value is there in committing to memory fine passages from literature?

9. What are the functions and value of literary criticism for the teacher? For the pupil?

10. What is the value of school dramatics? Should classic dramas, like Shakespeare's, be employed for such purposes?

11. Discuss the value of literary biography of authors in the school curriculum. Will it help the pupil to understand the writings of Goldsmith? Of Tennyson? Of Shakespeare?

12. What reasons are there for training pupils carefully in writing clear sentences? In making clear outlines?

13. Why should oral and written composition be kept in close relation with other work in English? With other school subjects?

14. In what ways can other departments lend support to the English?

15. What is the difference between "declamation" and oral English?

16. What is the modern attitude towards "oratory"?

17. How should poetry be read aloud?

18. Show by citations that modern literature is democratic in its ideals. Was ancient literature so?

19. Make out lists for guiding the pupils' reading in contemporary and recent literature.

20. Discuss the value of the short story for high school courses.

REFERENCES

- BRIGGS and COFFMAN. *Reading in the Public Schools*. Chicago, 1912.
- CARPENTER, BAKER, and SCOTT. *The Teaching of English*. New York, 1903.
- CHUBB, P. *The Teaching of English*. New York, 1902.
- COLBY, J. *Literature and Life in School*. Boston, 1906.
- COX, J. H. *Literature in the Common Schools*. Boston, 1908.
- Harvard College, *Reports on Composition and Rhetoric*. Cambridge, 1895, and later. -
Twenty Years of School and College English. Cambridge, 1896.
- HERRICK, R. *Methods of Teaching Rhetoric*. Chicago, 1898.
- LAURIE. *Language and Linguistic Method*. Edinburgh, 1893.
- MACCLINTOCK, P. L. *Literature in the Elementary School*. Chicago, 1908.
- SCUDDER, H. E. *Literature in the Schools*. Boston, 1888.
- THURBER, SAMUEL. Papers in the *Academy* (Syracuse), *Education*, *Educational Review*, and *School Review*.
- A full bibliography up to 1913 is given in the revised edition of Carpenter, Baker, and Scott's *The Teaching of English*, cited above.

CHAPTER X

THE CLASSICAL LANGUAGES AND LITERATURES

LATIN

PLACE IN THE CURRICULUM. — The position occupied by Latin in the curriculum of the secondary school is due primarily to tradition. During the Middle Ages and at the Revival of Learning, Latin was the medium of communication in science, literature, and politics. Consequently it was the first and most important element in education; supplemented by Greek and mathematics, it formed the whole curriculum. In the seventeenth century the native tongue began to form a small part of the course of study. This was followed in the eighteenth century by the modern foreign languages, and in the nineteenth by the various sciences. Practically all the time devoted to them was taken from that allotted to Latin and Greek. The process has continued until now Greek is omitted from the curriculum in practically all public high schools and in most private ones, and Latin has been reduced to modest proportions. Latin now occupies about one fifth of the total time of the secondary schools, but it has to maintain itself against vehement criticism and opposition. The critics maintain that Latin is not a “practical” subject, and that the results of Latin teaching are entirely disproportionate to the amount of time which it demands. The defenders of Latin urge two main reasons for its retention in at least its present condition: (1) its value as a mental discipline, (2) its value as a practical subject.

THE VALUE OF LATIN, or of any subject in particular, as a mental discipline, has been much impugned in recent years,

particularly by the psychologists; but there is a tendency now apparent to recede from the extreme position in this regard, and there is abundant testimony from unprejudiced observers in all walks of life to the value of Latin as a training instrument. For above every other subject it trains (1) the process of observation, (2) the function of correct record, (3) the reasoning power and general intelligence in correct inference from recorded observations. To this should be added its great value in developing the power of voluntary attention.

The value of Latin as a practical subject has to do particularly with the effect of the language in the cultivation of English style. In the English vocabulary a very large proportion of words in everyday use are of Latin origin, and it has been estimated that two thirds of the Latin vocabulary of the classical period has in some form or other come over into English speech. For the correct use of synonyms in English and the habit of expressing one's thoughts clearly, concisely, and cogently, a discriminating knowledge of Latin is indispensable, and while not every pupil in the school may be expected to develop a good style, nevertheless he should be given the necessary foundation for it.

When we turn to literature, we find that Latin is influential everywhere — particularly in our classical authors — by allusion, by quotation, by actual domestication. Many of our great English writers are permeated with Latin. We cannot expect that all will desire to feed their minds on the works of our greatest authors, however much we might prefer it; but certainly we should not deprive them of one of the most important elements in their enjoyment should they be so minded.

The criticism of the results of Latin teaching has borne more heavily in recent years, and teachers are coming to realize that this criticism has genuine foundation. There has been, therefore, much discussion as to improvement of method, and many suggestions, particularly by editors of textbooks. It may be

said in general that the tendency of these suggestions has been toward greater emphasis upon oral teaching and the testing of acquaintance with the language by the ability to read its ordinary forms at sight. It has been too true that the value of the exercise in translation, which, when properly done, should be very great, has been seriously impaired by the very widespread use of English translations, a practice which results in slow progress on the one hand, and dulled moral sense on the other. Then, too, in most of our colleges the classes, particularly in the earlier years, have been so large that adequate personal attention to individual students has been impossible, and this difficulty is becoming more and more serious in secondary instruction with the rapid growth of our public high schools. Administrative officers have shown a curious disinclination to treat languages with the same consideration that is extended to the sciences. While it is accepted without question that scientific instruction without individual laboratory work under the eye of laboratory assistants is impossible, the equally obvious fact that instruction in languages without similar practice can be only haphazard and slipshod, is either not perceived or knowingly neglected.

METHODS OF TEACHING. — Naturally in the teaching of any language we should begin with the essentials of grammar, together with sufficient exercises to insure the complete learning of the forms, and enough of the syntax to make the reading of simple sentences possible. This would be followed by easy reading, and then by more difficult reading, until the student acquires sufficient mastery to read with some ease whatever he would naturally come in contact with. And this is practically (with certain restrictions) what has been followed for centuries in the teaching of Latin. The question has been chiefly as to the nature of the instruction in the first year and the sequence of reading material. In the main the colleges have dominated the high school curriculum in America by their requirements for admission, and thus we find

that for a long period the course of instruction in the high schools has been the beginner's book, a certain amount of Cæsar, certain orations of Cicero, certain books of Vergil's *Æneid*. When the high school course has been four years in length, as is the case almost everywhere, one year has been devoted to every one of these four subjects. Where the course is five years, or six, teachers have enlarged it by the addition of Ovid, Nepos, Sallust, and in some cases have increased the time devoted to the beginner's book so as to spend upon it a year and a half.

In recent years there has developed a strong feeling that the prescription of so much reading has a deleterious effect upon the teaching in the schools, and that better results could be attained if there were less definite prescription of authors and more insistence on the ability to translate easy Latin at sight.

The first year of Latin is the most important work in the whole high school curriculum. This importance lies in the fact that the pupil is studying not only Latin, but the phenomena of organic speech. In some schools in Germany and in England the pupil makes his first acquaintance with a foreign language in the study of French; but this practice has not taken root in the United States, and there the first serious study of linguistic expression begins in the Latin classroom.

Difficulties of the Student. — Let us see for the moment what the problems of the Latin student are, what the English-speaking child will find difficult or unusual. First and foremost, he will be struck by the Latin forms. English is practically a formless language; the few terminations remaining are not sufficient to form a foundation for the careful study of the expression of ideas by means of termination. The pupil will now for the first time have to distinguish between the various cases of the noun and the various tenses and moods of the verb. This comes as a shock to the average English-speaking child, and it requires months upon months of careful

and insistent drill before the expression of case relations by changes in termination becomes second nature. For example, in an English sentence like, "The boy strikes the dog with a stick," outside of the *s* in the verb no indication of meaning is given by any termination, and the three substantives would suffer no change in form, no matter what change in meaning might be brought about by transposition. On the other hand, in Latin the syntax would be expressed not merely by the sense, but also by a formal difference in every noun. Furthermore, the pupil would be troubled by even the simplest syntactical structure. An English sentence like, "The father gave his son some money that he might buy the book," is comprehensible to the child without any serious mental effort; but in the Latin sentence he must become acquainted with the idea of purpose and its expression and the use of mood to take the place of the auxiliary. This difficulty is immeasurably enhanced when "to buy" takes the place of "that he might buy." Another difficulty which is none the less real is that of pronunciation. For the first time the pupil comes into contact with what is essentially the Indo-Germanic system of sound expression, from which English has seriously varied. Then, too, there is word order and its possibilities in an inflected language. With these difficulties staring him in the face, and with progress made exceedingly slow on account of the necessity of accurate thinking along several lines at the same time, the first-year Latin taxes the patience, the ingenuity, and the skill of even the best of teachers. And in the United States in particular, owing to conspicuous administrative incompetence, the work of the first year is usually in the hands of the most inexperienced teacher.

The Introductory Work; the Customary Method. — The material is provided in the numerous first-year books, which show almost every possible idiosyncrasy of method. It may be said in general that they embody the carefully thought out schemes of the individual authors. They follow two main

lines of presentation, one of which may be called the block system, the other the fragmentary system. In the latter — and by far the more influential — the lessons, particularly the earlier ones, are so divided that fragments of declension and fragments of conjugation alternate with each other; thus, either the nominative singular, or the nominative and accusative singular, or the nominative singular and the nominative plural of the first and second declensions are followed by the present indicative, singular number, or third person singular and plural, as the case may be. Subsequent lessons fill out the paradigms of the first and second declensions and the first conjugation, after which the other conjugations and the remaining declensions are taken up. In the meantime elementary rules of syntax, such as the agreement of the subject and the verb, the government of the accusative case, the ablative of instrument, the ablative of place, the dative of possessor, the objective or possessive genitive, the use of *ut* to express purpose, sometimes the use of *cum* in the sense of “when,” are scattered along according to the caprice of the author. The object of thus breaking up inflectional groups is to provide early in the course reading material which will have in itself some reason for existence, and thus avoid the aridity of the old-fashioned textbook. In the former class, the textbook gives the first declensions in their order, supplementing them only by so much of the verb inflection as seems necessary to make the construction of sentences possible; then follow the conjugations in their order. The earlier exercises from English into Latin and from Latin into English are largely confined to the translation of detached forms. The critics of the first system maintain that it divorces things that belong together; those of the second that it makes the early Latin work not merely dull, but practically hopeless, because the pupils see no evidence of progress. As a matter of fact, the superiority of the first method to the second is merely specious, and the fragmentary acquisition of forms carries with it many evils. A

third method of presenting forms, advocated by a few, is what one might call the topical treatment. The pupil begins with the study of a case throughout all its formations, and after proceeding through the declensions he takes up the verb similarly. Every one of these three methods requires a live teacher to make it successful, and practically, therefore, none shows any superiority over the other. Theoretically the second method is preferable, supplemented by the third wherever feasible, the first being the least defensible of them all.

The selection of the material of the first book involves the three divisions of forms, syntax, and vocabulary. It is generally agreed that unusual forms should be excluded, on the principle that only those in most common use are vital, while the unusual ones can better be learned (if learned at all) where they occur. Consequently the old apparatus of rule followed by exception has practically disappeared, and the beginner's book lays particular stress upon the normalities of language. This principle, however, suffers some modification in practice. It is frequently easier to learn the complete series, even though some of the elements are rare, than to break it up into fragments; the effort of mind is often much greater in the second case. The terminations are best learned in groups, even though examples of some of them are comparatively infrequent. Principal parts are best learned complete, though in the case of many verbs certain of them are never found. In the main, however, the principle is sound. In the case of syntax the situation is different. Comparatively little syntax should be given in the beginner's books, and this should be not necessarily the most common; but the most simple, for the learning of forms taxes primarily the memory, while the study of syntax exercises principally the reason. Therefore the indicative constructions should appear in the beginner's books, and only those uses of the subjunctive which make but slight demand upon the reasoning power, such as its use in

wishes, in expressions of purpose and result, and little else. It is customary in the beginner's books to devote the last few lessons to the more elaborate constructions; but conditional sentences and the whole body of constructions with *dum* and the like, *quin*, *quominus*, and concessive clauses would better be deferred to the second year. The same is true of the more involved relative constructions.

The choice of vocabulary obviously depends upon the aim of Latin teaching in general. If, it is generally argued, we taught pupils to speak Latin as we did formerly, we should naturally require a colloquial vocabulary, but since our chief aim now is to give the means of reading Latin literature, we must choose the vocabulary with this end in view. A number of beginner's books claim to limit the vocabulary to the words in most common use in Cæsar. This practice is sound, because it has been found that these words are also in common use throughout the literature, while birds and animals, furniture and everyday occupations would leave the pupil absolutely helpless before a page of any Latin author. The size of the vocabulary for the first year should be about 500 words, and the text-books usually show about that number. But no fixed list of words can be learned completely by all the pupils, and a certain margin must be allowed for forgetfulness, consequently the beginner's book would do well to show a vocabulary slightly in excess of 500.

The exercises in translation are usually divided into Latin-English and English-Latin. Some teachers hold that no translation from English into Latin should be expected until very substantial progress in the learning of forms has been secured, perhaps not until the middle of the year; but the weight of opinion inclines to the view that translation from English into Latin should begin with the first lesson. This work, however, is very much more difficult than translation from Latin into English, and the demands in vocabulary and syntax should accordingly be lessened.

The Oral or Direct Method. — Dissatisfaction with the results of the traditional method have led in recent years to the employment of the oral or direct method. The advocates of the latter insist that Latin should be taught as if it were a modern spoken language; consequently they follow in general the principles of direct teaching as employed in the teaching of modern languages. Almost from the very beginning Latin is the customary language of the classroom. At the outset short commands and questions having to do with the necessary activities and surroundings of the classroom form the means of instruction. The pupils are required to answer every question in Latin and to follow every command with a statement of what they are doing. As they progress the range of vocabulary is enlarged, but still restricted primarily to the ordinary activities of life. After a little time the teacher tells the class short stories in Latin, explaining the meaning of unfamiliar words in the same tongue and requiring the class to give him back the story in such Latin as they can command. In this method translation, whether from Latin into English or from English into Latin, is practically unknown. This is reserved for the period when the pupil, having obtained a ready command of the fundamental principles of Latin, is ready to begin that comparison of Latin and English idiom which renders translation so valuable an exercise. Drill in syntax is obtained partly by the oral exercises, partly by written work. To provide for this drill the teacher may require his pupils to embody such and such constructions in the written work, while in the oral work he may have the various ideas expressed first in one fashion and then in another, turned from active to passive, or from the independent to the dependent form. Short narratives composed of independent sentences may be rewritten so as to involve various kinds of subordination. The effect of such training is to make the forms of the Latin language second nature to the pupils, and to reduce by constant practice the strain upon the memory. The method requires a

great deal of ingenuity and readiness on the part of the teacher, for every opportunity afforded by any chance remark of the pupil must be improved at once; but in the hands of a competent teacher the results are claimed to be vastly superior to those of the old method. After some months the pupils have a greater grasp of the forms and easy syntax of the language, and are then prepared to go on to serious reading with much greater ease. The chief drawback of the direct method is one of time. The earlier stages require a great deal more time than is required by the old method, but the advocates of the new method maintain that what is lost in speed is more than gained in definiteness and quality of knowledge, and that in the subsequent years the previous delay is much more than made up. One of the important results of this method is that pupils feel that they have a certain control of the language and are thus relieved of the temptation to use unfair means in preparation.

Very recently in the United States an attempt has been made to modify the traditional method by adding to it some of the features of the new method. Recent textbooks give more attention to colloquial features, and the vocabulary of the earlier lessons has to do with the ordinary activities of life. But this choice of vocabulary is intended merely to facilitate the colloquial handling of the language by the pupils, and is expected to give way to the normal literary vocabulary as soon as the serious reading of Latin literature is begun.

Pronunciation. — Whatever method is employed, the initial difficulty is that of pronunciation. The Roman method is commonly employed. Objections are occasionally made to it, but its foundation is secure both in knowledge and in intellectual honesty. It is frequently said that we do not know how the Romans pronounced. This is true only to the extent that those who have not actually heard a modern language do not know how it is pronounced. We have a fairly accurate knowledge of the sounds of the Latin letters, and we have

special directions as to the position of the organs of speech in articulation. While some of these directions come from a comparatively late period, — as late, in fact, as the sixth century A.D., — yet the laws of linguistic development show conclusively that the directions of this period involve certain preceding conditions which can be postulated with accuracy. To determine Roman pronunciation we have, besides the directions of the grammarians just alluded to, transliterations of Greek words into Latin and of Latin words into Greek. We have inscriptional evidence as to the length of the vowels, occasional remarks in Latin literature touching upon pronunciation, and the evidence presented by the Romance languages, which modified in transition the Latin sounds after a definite manner. We are able, therefore, to give in the textbooks the sounds of the Latin letters with practically as much certainty as we can the sounds of a modern language in textbooks for foreign use. To the ear of a Cicero a modern Latinist would speak with an “accent,” but he would be understood. It is the business of the teacher to show in pronunciation a careful attention to exact enunciation and to require on the part of the pupils the same accuracy. The pupil should never hear a Latin word mispronounced by the teacher. The Latin that is to be translated should if possible be read aloud by the pupil, and such practice should be continuous. A little careful practice every day is better than a great deal at intervals. The teacher should pay attention particularly to the quantities of all the vowels in his own enunciation and to syllabic division; the pupil, however, should not be forced to learn anything but the quantity of terminations and penultimate syllables. The former should be learned in the acquisition of the forms, the latter on meeting with the new word. Inasmuch as Latin accent depends upon the length of the penult, it is not necessary to require a careful marking of the earlier syllables in the word, except where it is an obvious derivative of a form already known. Hidden

quantities, so called, should not be required of the pupils, but the teacher should be careful to pronounce them correctly as far as our knowledge extends.

The Later Reading. — In many of the older English schools and in those American schools with a curriculum of more than four years, the introductory work extends over into the second year; but in the new English schools and in the vast majority of American schools the reading of genuine Latin begins in earnest with the beginning of the second year. The arrangement of the curriculum for subsequent years differs in different countries. In general, Nepos and Cæsar are taken up first, and then a mixed combination, composed mainly of selections from Cicero, Ovid, and Vergil, but with possible substitutions of Livy, Sallust, and Terence, has been the habit. In the United States up to very recently the almost universal practice has been to devote the second year to Cæsar, the third to Cicero, the fourth to Vergil. The amount of Cæsar prescribed (four books) has proved to be a very severe task for the ordinary high school class. It has involved a definite advance every day, and it has thus been impossible in many cases to take account of weak students or to linger for the purpose of securing thoroughness. The plan recently adopted decreases the amount of reading specifically required and lays increased emphasis upon reading at sight and the acquisition of additional vocabulary.

Transition to Cæsar. — The transition from the beginner's book to Cæsar is difficult, and the pupil is apt to show a weakness entirely unexpected from the work of the previous year. This is due to the complexity of the periodic sentence. Word order and the various devices of subordination give a great deal of trouble. At the outset the teacher must be content with short lessons in which attention is paid particularly to the new constructions and the new words. He should also devote a good deal of attention to working over the Latin sentence into genuine English. The class should be drilled

in the difference between Latin and English idiom, and should be required to translate at least the review passage into correct English. The work done during the class hour should be of two kinds: the lesson of the previous day should first be reviewed, and the rest of the hour should be devoted to a preliminary sight translation of the work of the next day under the guidance of the teacher. As far as possible, the home work should be restricted to the study of syntax (often in written exercises) and vocabulary. Every now and then the pupils should be required to write out in class the translation of a small portion (if only four or five lines) of the day's lesson, and these written translations should then be criticized by the teacher from the point of view of the English expression. One such exercise is worth a dozen oral translations for the appreciation on the part of the pupil of the difference between Latin and English expression. The teacher must never lose sight of the fact that from the beginning of the second year the most important part of the training is the development on the part of the pupil of the sense of style, by which is meant good English as an offset to good Latin. If the advantage claimed for the study of Latin in appreciation of English style is to be secured, it can be done only in this way.

Cæsar furnishes particular problems. In the main his narrative is simple, concrete, narrow in range of ideas, and easily followed. In fact, no author in the whole Latin literature is better suited for the reading of the second-year Latin. But *Cæsar* shows a fondness for the insertion of speeches in what is called indirect discourse. These have nothing to do with the narrative, and could be omitted without disturbance. The length of these speeches in the first book has led many teachers to begin with the second book. Such a practice is faulty in principle; and, inasmuch as the speeches are not necessary to the narrative, it is far better to begin with the first book, and for the teacher either to translate or to paraphrase the speeches as they occur in order merely to give the

setting of the story. A good deal of stress has been laid upon the ability of the pupil to turn direct discourse into indirect discourse and the reverse, but it should be remembered that Cæsar is the only author whose style is characterized by indirect discourse in mass, and that, so far as the learning of Latin is concerned, the time devoted to the intricacies of indirect discourse would much better be devoted to more extended reading. Nevertheless, until we are prepared to give up Cæsar, some attention should be paid to the indirect discourse, and the speeches might well be reviewed toward the end of the year, when Cæsar's story is being studied as a whole.

In studying Cæsar due attention should be paid to the development of his narrative and to the Roman art of war. Pupils might be required after a campaign to write out an account of it, or they might be required to plan or describe a battle. Some attention may be paid to Cæsar as a man, his dealings with his troops, his attitude toward the State, the circumstances which led to the Civil War. But of course these studies should be supplemental merely; for after all, while Cæsar is history, he is being read primarily to learn Latin. If the plan of preparation indicated is followed, no particular effort need be made to develop the power to translate at sight, but a period may be devoted, perhaps as often as once a week, to sight translation only. The passage read may be merely a further section of the advance narrative, or interesting passages may be selected from the later books or from any other Latin of approximately equal difficulty.

During this year much attention must be paid to prose composition, and as this important exercise is for the purpose of systematic grammatical study, it should be done systematically from the beginning. The exercises should be graded in difficulty, and should follow a definite plan of syntactical development. They should, accordingly, not be merely based upon a small section of the text. All that can be expected is that the vocabulary should be that of the stage of

study and that the style should be narrative. If the subject can be made either identical with what the student is reading, or similar to it, so much the better. It is the habit of many to devote one period a week to prose composition. This is theoretically objectionable. It is better that a short exercise should be done every day. Review exercises embodying a number of principles previously studied may occupy the period every now and then; but one period a week devoted to Latin composition involves too long an interval between efforts. Oral composition in connection with the reading of the day may often be productive of excellent results.

When some of the *Lives* of Nepos are substituted for a portion of the Cæsar, the same general principle should be followed in the teaching, but the supplementary work would of course be different. Nepos is, however, not so suitable as Cæsar for this stage, because his vocabulary is much wider and involves many unusual words, and many of the conceptions are abstract. Nor does the brevity of the episodes serve to counterbalance the greater complexity of the periodic sentence.

Cicero. — Ordinarily Cæsar is followed by Cicero. Cicero not only represents the highest point of Latin classical style, but he was the greatest Roman orator and an important figure in the death struggle of the Republic. The orations usually chosen are the four against Catiline, the one on Pompey's command, and the one for the poet Archias. The orations against Catiline are the easiest of all, and have an important political significance. The *Pro Lege Manilia*, in addition to being a comparatively early speech, marks the beginning of Pompey's growth as a great figure, and also forms a good opportunity to study the rhetorical elements in the orator's style. The *Pro Archia* is in effect a eulogy of Greek literature and a wonderful example of the panegyric style. Sometimes the teacher prefers to read a different set of speeches for the purpose of focusing the attention of the pupils upon some

particular side of Cicero's multifarious career, and many teachers like to substitute for some of the speeches mentioned selections from Cicero's correspondence, chosen either to show the great orator's human side or to throw sidelights upon the history of the period. Some teachers regard Cicero as dull and uninteresting to pupils, and prefer at least to begin the third year with Vergil. This apparently unpedagogical practice is defended on the ground that Vergil, even if not thoroughly understood, is interesting on account of the narrative, that his style is not difficult, and that outside of the strangeness of the poetical dress, the narrative moves quickly and easily. Moreover, the syntax on the whole is easier than that of Cicero, because of the absence of involved sentences. Others begin the third year with Vergil, and after a time they take up Cicero, completing both Cicero and Vergil in the fourth year. But this is all pedagogically unsound. Vergil should be deferred to the fourth year, because his writings are pure literature, and need for proper appreciation and enjoyment as much maturity of mind as can be brought to them. On the other hand, Cicero makes but small demands upon the mental maturity of his readers. In teaching Cicero it is proper to go more into detail about the history of the later years of the Republic and the condition of parties at Rome. The work of the Cæsar year in this regard might well be amplified, and the attempt made to give the pupils some rational idea of the workings of the Roman constitution, but the main stress should, of course, be laid upon the interpretation of the speeches themselves. The teacher should possess a great deal of imagination, because Cicero is serious, ironical, humorous, jesting, or playful in turn, and his invective on the one side is offset by the deepest pathos on the other. Very often the point of the passage depends on the order of the words or the application of a particular word. References that seem blind can be lighted up by modern instances. Cicero's personal character and the main facts of

his personal life should not be overlooked, and the teacher should try to lead his pupils to some understanding of the man whose soul was torn in two directions, who felt always the conflict between inclination and duty, who followed a sinking cause with his eyes open and remained true to his convictions even at the cost of life.

Ovid. — When Ovid is read, whether after Cæsar or Cicero, it serves as an introduction to Latin poetry and to ancient mythology. It also relieves the early study of Vergil of the drudgery usually attendant upon the shift from prose to verse, and makes it possible to treat Vergil as literature from the beginning. Selections from the *Metamorphoses* are usually chosen, because the narrative is easy. The chief difficulty is one of word order. To relieve this some editions have the earlier selections rewritten in prose order. Scansion also is a serious exercise for most pupils, even when they have been carefully trained in pronunciation from the beginning. Most teachers are content if some appreciation of rhythm is developed, and pay little attention to the conflict between verse and word accent that regularly obtains in the first part of the verse. Others maintain that, as Latin is a language of almost “level stress,” the verse will scan itself, if the words are pronounced as they should be pronounced in prose. Few teachers, however, are able to reach this point of perfection, even in their own scanning.

Vergil. — It has been objected that because the works of Vergil represent the highest reach of the Roman imagination and the most finished product of Roman literary art, they should be reserved for the later period of study, when the attainments as well as the maturity of mind of the student are greater. If we were sure that our students were going to continue the study of Latin for some years, this objection would weigh; but the great majority of secondary pupils terminate their study of Latin with the high school course, and it seems indefensible that any should give up Latin after four

years' study without having had the opportunity to read Vergil.

Since most American high schools prepare for the college examinations at the end of their course, it becomes necessary in the last year to devote considerable attention to a review of grammar and syntax. Vergil, however, is not well suited for this. His style is in general very simple; subordination is conspicuous by its absence; the subjunctive constructions that are so common in all Latin prose are comparatively rare. The syntax of the cases can, it is true, be studied with some effect because most of the so-called poetic usages have to do with case constructions; but these are the easiest, after all, and the pupil needs most to review the construction of the verb. This is best accomplished by the careful writing of Latin during the whole of the last year.

The selection usually read is the first six books of the *Æneid*. This is justified, first, by its extreme interest for all kinds of pupils, secondly, by the fact that neither the *Bucolics* nor the *Georgics* treat matters of universal appeal. The subject and the vocabulary of the *Bucolics* were exotic to the Romans themselves. That of the *Georgics* is too specialized to warrant any great attention on the part of high school pupils. The first six books of the *Æneid* are without question the most important part of this poem, and they have a world interest which is not so much felt in the latter books.

In teaching Vergil the aims are altogether different from those that dominate the teaching of Cæsar and Cicero. Here is no place for the study of military operations, the colonial system or method of government, nor is there any occasion for investigation of party feuds and social relations. Since the Roman epic is a purely literary creation, stress should be laid as far as possible upon the literary element. The ancient mythology, the ancient simplicity of life, the ancient morality, all claim attention; but these are subordinate to the far-reaching literary interest which Vergil exercises upon all

subsequent authors. Most of the school editions contain copious parallel passages from later literature. In many cases these are not genuine parallels, and the pupil gets either no impression or only a very vague one from reading them. This ought not to be the case. An attempt should be made to focus the attention of the students upon certain important features of English literature and upon certain particular authors who have been under classic influence. With that in view it would be well to treat at greater length the influence of Vergil upon Shakespeare, upon Tennyson, upon Milton, and so forth. This can be done usually with the material provided in the editions. The pupils should also be taught throughout to visualize the scenes, to form their own judgments as to the narrative in its various stages, to become independent in attitude. Here, too, extreme care should be exercised in translation. Poetic language should be rendered poetically. It will be the first experience of most students in distinguishing what is prosaic in expression from what is poetic, and the fact that Latin verse differs from Latin prose will be better understood if the difference between English prose and English verse is also shown. Images and metaphors should not be washed out. Due attention should be paid to the artistic setting, the picturesque qualities of every scene. The teacher should never lose sight of the fact that in teaching Vergil he is teaching the principles of literature in general, just as in the earlier years of the course he was teaching universal grammar. In this way Vergil ought to be not merely the proper culmination of the secondary Latin course, but also an important element of the pupil's general culture.

Other Selections. — With a longer course Sallust's *Catilina* might be read as a foil to Cicero's *Catilinarians*. Variety may also be attained by selections from Terence or Livy, or by more extended anthologies, a large number of which are now available, adapted to the wants of pupils of different grades.

GREEK

PURPOSE AND VALUE. — It is well to begin with a clear idea of the end in view in learning Greek, as the first regulator of method in teaching it. Complete agreement as to that end there has probably never been; and in four centuries views have undergone many changes. The carefully limited statement of the Prussian *Lehrplan* of 1901 is: "An acquaintance, based on adequate knowledge of the language, with a certain number of literary works of special importance for content and form, and by this means an introduction to the thought and civilization of ancient Greece." Here is not a word that suggests any other purpose in studying Greek than in studying Chinese; the official directions to teachers hardly touch upon what is really the heart of the teacher's task; they tacitly assume, in the traditional way, that learning a foreign language is a radically different process if the language is ancient. Current formulas in England and America, however various in form, fall into two classes, according as they put in the foreground the content of the study or the effect on the student. But these two conceptions, instead of being opposed to each other, are simply two aspects of one mental activity; they may be reconciled in a single statement, comprehensive and brief. The starting point for this is a great historical fact, which may be put in the words of one of the best-known scientists of England and America, Sir William Osler: "The tap-root of modern science sinks deep in Greek soil, the astounding fertility of which is one of the outstanding facts of history. . . . Though not always recognized, the controlling principles of our art, literature, and philosophy, as well as those of science, are Hellenic." Corresponding to this undisputed fact of history, and somehow closely related to it, though we cannot here discuss the relation, is the following psychological fact, verified in centuries of experience. For minds not unadapted to it, the process

of acquiring, under good instruction, a first-hand acquaintance with the Hellenic mind, as embodied in the existing works of ancient Greeks, is peculiarly formative, enlarging, disciplinary. No educational instrument yet known can fully take the place of this, as none can take the place of mathematics. This brings us to the simple and comprehensive formula: The prime object of Greek study is to gain a first-hand acquaintance with Hellenism, as a great force in civilization; the first aim in teaching Greek is to lead pupils to a personal acquaintance with that force. The disciplinary effect, the formal training, and all desirable ends, are included in that central aim, as auxiliary or incidental to it. That Hellenic force has been profound, lasting, pervasive. Along one line it reached even the extreme Orient, long before the Renaissance in Europe. It has recently been demonstrated that through Alexander's conquests, carrying Greek art to northern India, where Buddhism arose and matured, even China and Japan received from Hellas a potent influence on their sculpture and painting. And now this influence, carried eastward to the edge of Asia, has there met the broader stream that flowed westward through Europe to America and across the Pacific. Such far-reaching facts in the development of mankind must continue to urge all who would understand the intellectual world of to-day and the movements of history to know Hellas for themselves. And really to know Hellas is to take into one's self directly something of that original force, still unexhausted, still fertilizing the individual mind that is brought into real contact with the art, literature, and thought of ancient Greece. Such are the facts and experiences that must draw many of the stronger and more aspiring minds to this study.

The Approach to the Hellenic Spirit. — When we would approach the Hellenic spirit most directly, it is embodied, first, in countless examples of Greek art still existing, more or less injured, in European and Asiatic Hellas, and in the museums of Europe and America; and secondly in a copious

literature. Where the former are accessible, as in our larger cities, no opportunity to become acquainted with them should be neglected. But for general educational purposes literature has this advantage over all other arts, that its originals can by printing be reproduced perfectly, cheaply, and in any number of examples. If we will, we can know these books nearly as well as any Greek could. Only we must first learn the language, for translations are but poor copies. In school and college the Greek language is to be taught and studied primarily as offering the only direct access to the great books. For while Euclid and perhaps a few other authors can be adequately read in translation, neither Homer and the dramatists nor Thucydides and the orators nor Plato and Aristotle can be so read. For these the content is inseparable from the original form. And unfortunately Greek is a difficult language. Its difficulties may be considered in four groups, which present themselves to students in the following order. First, an alphabet differing in part from our own. This is the least difficulty, but is serious during the first weeks. Second, a large vocabulary, far less represented in everyday English than is the Latin or French. Third, a rich inflectional system, especially for the verb. Fourth, a wide divergence from English in syntactical idiom, a divergence due chiefly to the third group of differences, the copious inflections. It is really the verb that is at the bottom of all serious troubles after the alphabet is learned; and too often the verb is neglected, with disastrous results. Taken all together, it is not too much to say that as large a bulk of grammatical acquisition is required to prepare for the best colleges in Xenophon and Homer as is required for preparation in Latin and in elementary French and German combined. Nothing is gained by blinking these difficulties. It is better to face them, and attack them in order.

METHOD FOR BEGINNERS. — The first step in learning the alphabet is to copy out both capitals and small letters,

the teacher indicating the best way of writing each where a question can arise. Some would follow the cursive manuscript forms now used in Greece. This has advantages; but unless one lives in a Greek-speaking community, keeping nearer to the usual printed forms leads more directly to the main goal. Next, the names of the letters should be copied out, in Greek characters, the pupil pronouncing each one aloud repeatedly. The written accents are so troublesome that one is inclined to relax the requirement of strict accuracy at first, hoping to take them up more carefully later. That is a mistake; to correct a habit of inaccuracy once acquired takes more time and effort than does accuracy from the beginning. The fundamental rules are few, and the whole subject less difficult than English accent is for foreigners. And careful pronunciation should accompany every step. This raises the question, what pronunciation?

Pronunciation. — As with writing, it leads most directly to our main goal, acquaintance with the *ancient* literature, to adopt the compromise in pronunciation which is recommended in recent grammars and by the Classical Association of England and Wales. The principle of this compromise is simple: to pronounce as the Athenians did about 400 B.C., as nearly as is practicable for our classes. The latter consideration leads us to adopt substantially the modern Athenian sounds for ϵ , o , ϕ , θ , χ and to give ω a closer sound than the ancient, like that of German \bar{o} ; the ancient sounds in these cases would, for our classes, be so difficult as to demand for mastering them a disproportionate amount of time. For the same reason it is not thought worth while to attempt the ancient pitch accents; we pronounce them all, in the present Greek fashion, as we do the English stress accent. Long and short vowels, however, it saves time in the end to discriminate carefully; "hidden quantities" are few in Greek. To Plato no doubt our best reading would have sounded very barbarous, perhaps unintelligible. But so would our reading of Shakespeare's

lines have sounded to Shakespeare; yet that does not make them less living to us. Some would see in this example an argument for the modern Greek pronunciation for ancient Greek. That, however, is to overlook the decisive differences in the two cases. The change in English since 1600 has not gone so deep that our pronunciation destroys all Shakespeare's rhythm, confounds the commonest words, and turns a phonetic spelling into an irrational chaos. The modern Greek pronunciation does all that for Sophocles. Considering the centuries that have elapsed, the Greek language has been conservative; some of the present characteristics began to appear before 300 B.C.; the popular speech of Greece is euphonious and expressive and has an interesting literature. But the wealth of the old literature was a constant force toward the retention of old spelling, while pronunciation inevitably changed. When, therefore, the modern sounds of the letters are applied to the poetry of twenty-three centuries or more ago, rhythm disappears, spelling becomes chaotic, and the language far harder to acquire. For an approximate illustration in English we should take, not Shakespeare, but Chaucer. To read his lines as verse we must return as well as we can to his pronunciation; in good teaching of Chaucer that is now done.

Oral Methods. — But precision in pronunciation on the system adopted is essential. This is one item in the application of the general principle that Greek, like any foreign language, should be taught as a living speech. As for "dead languages," of course Elizabethan English is really as dead as the language of Xenophon; the latter can be made to live for us in the same way as the former, and not otherwise. That is, ear, hand, and tongue must from the first be as accustomed to Greek words as is the eye, precisely as in the best teaching of modern languages. The advance of recent years in teaching these, especially in France, Germany, and England, is even more needed in teaching Greek, and is just as possible.

“Read, write, speak” was the rule of the Jesuit schools three centuries ago; the notion that Greek and Latin are to be learned merely by reading, without accompanying oral use, belongs to the nineteenth century, and is a fundamental error. How much use can be made of conversation will depend on the knowledge and skill of the teacher; more use can be made than seems possible to one who has not persistently tried for it. But the principle is not bound up in any “method”; what it requires is that by every available means the ear be trained to understand Greek words when spoken, and that the student be accustomed to reproduce Greek accurately, both orally and in writing. The better the teacher’s own command of the language, the more he can vary these means, and the better results he will obtain. Also the more Greek can be used for saying what must be said in the classroom, the more rapid the progress. But any teacher can insist on good reading aloud, writing from dictation, translation from another’s reading, and on reciting and writing from memory both paradigms and connected passages. By such exercises, too, one gains the power to go further in that direction. There seems to be a physiological reason for the plain fact of experience, that a foreign tongue ceases to be alien and becomes a natural and living mode of expressing thought, only when, like the mother tongue, it is firmly held by all four kinds of language memory, those of the ear, hand, and voice, as well as that of the eye. To exercise all alike from the beginning makes the learner’s progress more rapid, because each step is more secure.

Reading. — For mastering regular Attic inflections, and of course for obtaining any considerable vocabulary or a fair knowledge of ordinary syntax, two things are indispensable. These are a large amount of reading in easy Attic prose, and along with this, not after it as a special exercise, much reproductive use of the language. To both too little attention is given in American schools. Those who condemn Greek com-

position from the notion that this is taught as an end in itself are attacking a man of straw; nowhere has it ever been so taught. But for learning to read any language accurately no other means can take the place of writing. And if to prepare pupils rightly for the examination in elementary French or German some two hundred pages of reading are requisite, how much Attic Greek must be read to obtain equal proficiency in the far more difficult language? Can one hundred and fifty pages of Xenophon suffice? Probably five hundred would be nearer the mark. The disproportion and the error of method in the usual practice are plain. Rereading and learning by heart, good as they are, do not meet the need. Too much rereading dulls the interest, and that is a capital mistake. What an eager young mind craves is variety, new combinations, the repetition that comes with these is more effective than twice that repetition through reviewing. For the vast apparatus of Attic conjugations, for the two or three thousand fundamental words, and for the common syntax, no single one hundred and fifty pages can offer enough combinations. Still more is this true of what we group together as idioms, the un-English ways of saying things, ways that grow naturally from the wealth of inflections, but are impossible in a language so little inflected as English. Just because they are unnatural to us, but are the warp and woof of Greek expression, the pupil must become familiar with a mass of them by meeting them in scores of variations; to repeat a few of the combinations a score of times is not enough. How to meet this difficulty is a serious problem, which we have scarcely faced, much less solved. The solution is to be sought in two places. First, a large amount of simple Attic prose, as varied as possible, should be read before the *Anabasis*. Disconnected sentences will not serve, for several reasons; first, because they are intolerably dull. And nothing read before the *Anabasis* should destroy the freshness of that interesting story by anticipating its distinctive vocabulary or its narrative; de-

tached sentences that spoil both by anticipation are a pedagogical sin. In part the place must be filled by modern compositions. *A Greek Boy at Home*, by Dr. W. H. D. Rouse (London, 1909), whose experimental work in the Perse School at Cambridge (England) has for a decade been doing much for classical teaching, can be commended from personal experience as interesting and practical, and it can be taken up in the first week. It has the merit, too, of introducing early the commonest particles and idioms of sentence connection, which play so much larger a part than in Latin or any modern language. Later some parts of Lucian can be used; when the need is more widely realized, a wider choice of suitable texts will soon be provided in convenient editions. Secondly, we must not be afraid to postpone a little the reading of Homer, that the immortal epics may be the better enjoyed. Colleges that have classes for beginners in Greek are as directly concerned as the schools in attacking such questions as these, though it should not be forgotten that details of the solution may be much affected by the age of the class and by their previous studies. We must here confine ourselves to general principles, observing that youths of fourteen or fifteen can learn paradigms, and perhaps can learn passages by heart, more easily than those of eighteen or older, while the arguments of the orators and the thoughts of Plato's *Apology*, *Euthyphro*, or *Crito* are harder for young people to comprehend.

Minor Principles of Method. — Three topics, under the general subject of method, still demand a few words. First, six hours a week in the class are far more than twice as effective as three hours; less than five hours a week means a sad loss of efficiency in the first year of any foreign language. The secret of the rapid strides which children make in learning German when living in Germany is not in the increased number of hours given to study, but in the increase in the number of hours of exposure to German, with the constant gentle urging, which daily life brings upon them, to listen and talk as well as

write and read. The classroom is a poor substitute for all that, but is the best we have; we should make as much of it as we can. Second, in the writer's experience, Greek syntax makes little trouble for pupils who have really learned the inflections. It is hazy notions about these that make syntax and syntactical idioms appear hard. The thing to emphasize constantly during the first five hundred pages of reading in Attic prose is the inflections, particularly of verbs; without a firm grip on these a student can have no real knowledge of Greek, but only invertebrate and feeble notions, which were better replaced by a real knowledge of French. And a teacher must not expect this mass of forms to be fully digested until several hundred pages have been read, with much reading aloud and writing and much reviewing of set paradigms. Third, what is commonly known as "sight reading," if treated as a separate exercise and as somehow distinct from right reading, is a snare and a delusion. Reading is merely taking the writer's meaning from his words, written or printed. Reading Greek or French is not different in that respect from reading English. The pages a pupil is set to read should be properly graded to his previous attainment. That being assumed, every sentence should be first read as well as possible at sight. That is, the pupil should be trained always to take the sentence as it comes, gathering the meaning as he proceeds, from all the indications before him. Precisely as, in learning the mother tongue, children enlarge their knowledge mostly by inferring from the context and the situation, so a great deal that is new can be inferred on every page. For some months all this new reading should be done in class, the teacher giving the meaning of new words when this cannot be inferred, but guiding the class to make all needed inferences that can be made on the basis of what they already know. This practice both increases speed and habituates to the right method, while it still leaves plenty for the pupil to do in reviewing the same passage for the next session. But any kind of

reading which cultivates a habit of stopping short of a close approximation to the writer's exact meaning is vicious. The purpose of those who first gave vogue to "sight reading" was to increase the pitifully small amount of reading then usually done; the purpose at least was good.

The above outline deals only with the teaching of the language in the early stages. This is not the place for the discussion of method in the more advanced work of the college, after a fair reading command of the language is acquired.

PLACE IN SCHOOLS. — The schools of different countries have developed on such different lines that comparisons in regard to any branch of study are difficult to make and are peculiarly open to misunderstanding. The intense interest in Greek during the earlier Renaissance soon declined. It was in Protestant Germany and England that Greek literature was most highly esteemed, permeated most thoroughly the highest intellectual life, most strongly influenced the men who created the modern classics, and there it has held the largest place in the school training of the educated class.

For *German schools* a new era began with the reorganization of the Prussian educational system after the humiliation of Prussia by Napoleon. The school which led to the university and was intended for the early training of all members of the learned professions and all higher state officials, though it was open to all boys whose parents could send them, was the gymnasium. This was meant to be the stronghold and propagator of the New Humanism, the heart of which was the appreciation of Hellenism, as exemplified in all the makers of classical German literature, notably in Lessing, Goethe, and Schiller. Latin was given the largest place in the new gymnasium, but Greek stood beside Latin for the last six years of the course. And without passing through this course there was no entrance to the university, therefore none to a profession or to high civic office. The Prussian schools, controlled by the state, were on the whole so superior that they

became the general model for all other German states. Further, the privileges granted only to state schools made it impossible for good private schools for boys to grow up beside the state schools. The system as a whole amounted to a degree of propulsion toward the study of Greek such as England and America never approached; that of France was similar, but less rigid. Two large results followed. First, Greek was taught and learned with a thoroughness nowhere else equaled by so large a fraction of the youth of a country. Second, as mathematics, natural science, the native and other modern languages and literatures became more and more important for a liberal education, and yet could not be adequately recognized in schools that gave so much time to classics, the revolt against this educational monopoly was most justified and was strongest in Germany. The centralized state control made it harder than in America for public opinion to effect changes; but changes had to come. Under the present Emperor they have been coming rapidly, and are likely to go much farther; and Greek is the subject most affected by them. In two ways Greek is crowded out. First, students are now admitted to university privileges from other schools, without Greek; second, more room for modern subjects must be found in the gymnasium by restricting the time allotted to Latin and Greek. As one manifestation of the latter tendency, the plan of the so-called Frankfort system seems to promise most for the retention of Greek. By this plan Latin is not begun till the fourth year of the nine-year course, being preceded by three years of French. Greek is not begun till two years later, and is then studied intensively for four years. If this shortening of the time leads to the adoption of improved methods of teaching, along the line of the vastly improved teaching of modern languages that is now enforced in all Prussian secondary schools as in all French lycées, probably more Greek can be taught than was possible under the old plan.

In *England* the establishing of classical schools in the sixteenth and seventeenth centuries was a widespread movement, as truly popular as any such activity could be in those times. It was always recognized that many who desired higher education, and who would by it be fitted to render public service in church and state, were sons of poor parents. Hence every educational foundation provided in some form for gratuitous, or partially gratuitous, teaching of a certain number of poor boys. In all such schools Greek was a firmly established subject of study by 1660, and has continued to be so. In the latter half of the last century a "modern side," without Greek, also became usual, and a demand for exemption from Greek for university entrance made itself felt. The newer universities do not require it, and the question is under discussion at both the older institutions. At Cambridge German or French is allowed as a substitute for Greek in the regulations for the "Examination in Modern Languages for the Ordinary Degree," an innovation which probably foreshadows a like concession with regard to the requirements for the "Previous Examination." At Oxford, however, the proposal to make Greek non-compulsory in the cases of candidates presenting themselves for honors in mathematics and natural science was rejected in Congregation (November, 1911) by a majority of 236. As regards the preparatory schools the Report of the Curriculum Committee (1910) suggesting that Greek should not be commenced "until a boy had reached a certain standard in other subjects, such as English, Latin, and French," was laid before the Headmasters' Conference at Sherborne, and is still awaiting their formal consideration. But nowhere else is Greek more firmly entrenched in the estimation of the educated classes than in England and Scotland; this must have for a time a conservative effect in the schools. The amount of time traditionally given to the subject, however, must certainly be diminished, and also the number of those who drop out by reason of failure to attain, before the age

limit, the standard set for the successive forms. It should be added, on the other hand, that youths to whom the subject is adapted, and who take the full training of a fine English school, including verse-composition, and then honors in classics at Oxford or Cambridge, obtain a fuller mastery of the Greek language and a deeper understanding of Hellenism than is imparted by the corresponding course of any other country.

In *America*, the English colonists, following the example of the mother country, began early to found grammar schools, in which Latin should be taught, and a beginning of Greek in the New Testament. Before the Revolution also the endowment of "academies" as another class of secondary schools had been well begun and it continued into the last century, to be succeeded by the still more popular movement for establishing free public high schools. One of the chief functions of the academy, as of the grammar school, was to fit boys for college, and hence to start them in Latin and in the elements of Greek; the high schools were intended rather to furnish a better education for those who would not go to college. Preparation for colleges of the old type was for them always a secondary aim; and has been more and more subordinated as the other aim has broadened and turned more toward vocational training, or at least toward such teaching as would more directly facilitate bread winning. In the newer states, of course, where the state universities have always given more attention to applied science and purely modern subjects, the high schools of each state have stood in close connection with its university; but that brings them no nearer to Greek. The great increase in the number of pupils whose home speech is not English has been a large factor in this development of the high schools. Accordingly, while many of the earlier high schools included Greek in the curriculum, few, except large high schools, now do so, and many of the largest, as in New York and Chicago, do not. In many states, as Iowa and Minnesota, no high schools teach any Greek. The

surviving grammar schools and larger academies generally teach it to those who desire it. Meantime, with the increase in wealth and advance in ideals of education, the demand for proprietary and endowed schools of the highest class has lately been growing. This has filled to overflowing the existing schools of this sort, and has brought into being many new ones. These are largely, if not primarily, preparatory for college and technical schools, and hence include Greek for those who wish it. They may prove to be one of the strongholds of Greek instruction, since they are in a better position for adopting improved methods of teaching than are the public schools, and their teachers' advice carries more weight with parents and pupils. Finally, it should be mentioned that the Roman Catholic Church maintains not a few colleges and schools, including some for girls, in which Greek is taught. Also, some groups of immigrants from Germany have been active in providing classical teaching for their sons. Notably the Lutherans have a series of flourishing schools more closely modeled on the German gymnasium than any others in America.

Amid the conflicting currents of life in America it is difficult to sum up the present situation with reference to Greek study, and impossible to foretell the future. The materialistic trend of the whole modern world toward money-getting is hostile to studies that seem to have no direct bearing on that. On the other hand, the deep idealistic strain and the passion for the best that are so characteristic of the race that America is slowly forming out of many heterogeneous elements, offer ground for hope. Whatever the teachers of Greek can lead their pupils to feel, in adult life, has been good in their own mental experience, will be kept and made available for their children.

VISUAL AIDS

LATIN AND GREEK. — The various schoolbooks, including beginners' books and editions, are now, as a rule, profusely illustrated with maps, diagrams, pictures of ancient sculpture and coinage and, in the case of Cæsar, with photographs of the present appearance of the ancient battle fields.

Besides the textbooks, however, there are many other publications for the use of students and for classroom illustration. Of prime importance are large maps, the best of which are those of Kiepert (Reimer, Berlin). There are numerous school atlases in all countries.

A capital book is Hill's *Illustrations of School Classics* (London, 1903), which gives numerous illustrations covering the fields of religion and mythology, history, and antiquities, with a special chapter on buildings. This may be well supplemented by Schreiber's *Atlas of Classical Antiquities* (Macmillan, 1895).

Lantern slides have been prepared in great numbers by G. R. Swain, Lockport, Illinois, to illustrate Cæsar's life and campaigns (400 slides) and Greek and Roman archæology in general. The Records of the Past Exploration Society (Washington, D.C.) have issued forty slides illustrating Vergil's *Æneid* as well as sets illustrating Pompeii (50 slides), Homer (65 slides), and Greek and Roman mythology (50 slides). These are expensive, but very fine. Excellent and cheap half-tone prints of classical architecture and sculpture are issued by the Bureau of University Travel, Boston, Massachusetts; the Perry Pictures Co., Malden, Massachusetts; A. W. Cooley, Auburndale, Massachusetts. Washington University, St. Louis, will furnish slides based on the remains and reconstruction of the Saalburg Camp.

For the Gallic War we have also Oehler's *Bilder-Atlas zu Cæsars Bücher de bello Gallico* (Leipzig, 1890), and Von Kampen's *Quindecim ad Cæsaris de bello Gallico commentarios*

tabulæ (Gotha). L. Gurlitt, has also published six *Anschauungstafeln zu Cæsars bellum Gallicum* (Gotha).

W. B. Harison of New York has issued a very extensive and cheap collection of *Illustrations for History Notebooks*, in which there are outline maps as well as illustrations of every conceivable ancient object. These can be made very serviceable.

Visual aids have a prominent place in the direct method. For this purpose Dent and Co. (London) have issued a number of colored *Wall Pictures of Roman Antiquities*. These may be supplemented by Launitz's *Wandtafeln zur Veranschaulichung antiken Lebens* (Cassel). Cybulski's colored *Tabulæ quibus antiquitates Græcæ et Romanæ illustrantur* (Leipzig, Koehler) are also invaluable for such use. Bell and Co. (London) have recently issued a series of sixteen colored picture cards, with vocabularies and exercises covering a similar ground. The pictures in Gurlitt's *Lateinische Fibel* and *Lesebuch* (Berlin) could easily be reproduced, and would give much variety to the material.

Especial reference should be made to Hensell's *Modelle zur Veranschaulichung antiken Lebens* (Diesterweg, Frankfurt a.M.). These models have to do with ancient clothing and life and with military engines. They could easily be reproduced by the manual training department of any school. They are not expensive when the size and demand for such models is considered.

TOPICS FOR FURTHER STUDY

1. What in recent years has been the tendency in the American high school in the number studying Latin? Greek?
2. Compare the amount of time devoted to Latin in the American high school with that given in the various types of secondary schools of European countries?
3. What difference in the results of the study of Latin are discoverable in a comparison of American high schools with European secondary schools? In methods? In textbooks? In curricula?

4. Test the assigned values of the study of Latin in a study of any one given high school, with students now in school. With graduate students. Compare Greek.

5. Compare these results with the results of similar tests for other subjects.

6. Compare in any one high school or other institution the general class or school standing of students taking Latin or Greek with those who do not. In what respects does such a study give evidence of the educational value of the subject, and in what respects not?

7. In what respects are the problem of interest and the problem of effort in education revealed through the study of Latin? Of Greek?

8. To what extent is the oral method of teaching applicable in Latin? What peculiar values does it have?

9. What visual aids to the teaching of Latin and Greek can be used and to what extent should they be used? What are the pedagogical and the educational value of such aids?

10. Can the values of the study of Latin or of Greek be measured by quantitative methods?

REFERENCES

- BENNETT, C. E., and BRISTOL, G. P. *The Teaching of Latin and Greek in the Secondary School*. New ed. London and New York, 1911.
- BREUL, KARL. *Greek and its Humanistic Alternatives in the "Little-Go."* Cambridge, 1905.
- COOKSON, C. *Essays on Secondary Education*. Oxford, 1898.
- CORCORAN, T. *Studies in the History of Classical Teaching*. Dublin, 1911.
- ECKSTEIN, FR. A. *Lateinischer und Griechischer Unterricht*. D. H. Heyden, Ed. Leipzig, 1887.
- England. Board of Education. Publications, particularly:
 The Teaching of Latin in the Perse School, Cambridge. *Educational Pamphlet No. 20*. London, 1910.
 The Teaching of Greek at the Perse School, Cambridge. *Educational Pamphlet No. 28*. London, 1914.
 The Teaching of the Classics in Secondary Schools in Germany. *Special Reports*, Vol. 20. London, 1910.
- GARNE, J. B. *Handbook for High School Teachers of Latin*. Cape Girardeau, 1909.
- HEADLAM, J. W. Teaching of Classics in Secondary Schools in Germany. In England, Board of Education, *Special Reports*, Vol. XX. London, 1910.

HECKER, E. A. *The Teaching of Latin in Secondary Schools*. Boston, 1909.

JONES, W. H. S. *The Teaching of Latin*. London, 1906.

KELSEY, F. W. *Latin and Greek in American Education*. New York, 1911.

KOHL, O. *Griechischer Unterricht*. Langensalza, 1898.

MATTHIAS, A. *Praktische Pädagogik für höhere Lehranstalten*. Munich, 1908.

MICHAELIS, G. *Welche Förderung kann der lateinische Unterricht an Reformschulen durch das Französische erfahren?* Marburg, 1902.

NORWOOD, C., and HOPE, A. H. *Higher Education of Boys in England*. London, 1909.

Recommendations of the Classical Association on the Teaching of Latin and Greek — being a series of Reports by committees. London, 1912.

ROUSE, W. H. D. *Classical Work and Method in the Twentieth Century*. London, 1908.

Teaching of Latin and Greek. *Proc. Scotch Classical Assoc.*, 1910-1911.

The Teaching of Classics (brief description of his application of the direct method to Greek and Latin). In *Athenæum*, Sept. 17, 1910, pp. 323-325.

SABIN, F. E. *The Relation of Latin to Practical Life*. Chicago, 1913.

SANDYS, J. E. *A History of Classical Scholarship from the Sixth Century B.C. to the Eighteenth Century in Germany, and the Nineteenth Century in Europe and the United States*. Cambridge, 1903-1908.

The School for the Reform of Latin Teaching. *Reports* for 1911, 1912, 1913, 1914. London.

SLAUGHTER, M. S. *The High School Course in Latin*. Madison, 1908.

WATSON, FOSTER. *English Grammar Schools to 1660*. Cambridge, 1908.

WOODWARD, WM. H. *Studies in Education during the Age of the Renaissance, 1400-1600*. Cambridge, 1906.

The Year's Work in Classical Studies, edited annually by W. H. D. Rouse for the Classical Association (London, John Murray), contains each year a report on recent pedagogical discussions.

See the files of the *Journal of Education* (London) and *School World* (London), especially since 1910, on the status of Greek at Oxford.

The Classical Weekly, published at Columbia University, New York, and the *Classical Journal*, published monthly at the University of Chicago, contain much material relating to the classics in American schools. So also do the files of the *School Review*, University of Chicago, and the *Educational Review*, edited by President Butler of Columbia University.

CHAPTER XI

MODERN LANGUAGES

PURPOSE OF STUDY OF MODERN LANGUAGE.—

Modern languages are studied in the secondary school primarily for their practical value. Through the choice and study of material a cultural value is added. Moreover, the processes involved in learning a foreign language are conceded to have general educative value; they serve to clarify, deepen, and broaden one's knowledge of language in general as a vehicle of thought. The practical goal sought in the course may be regarded from at least two points of view. We may stress the utilitarian side, the practical oral control of the language, allowing the reading of books to appear as a natural outgrowth, or we may make reading the chief aim. The first way might seem upon the surface both a desirable and a logical one to pursue. Yet experience teaches us that the school is not a favorable place for the acquisition of a language technique commensurate with the energy that would have to be expended and for which there is not sufficient time. The field of reading, on the other hand, is not only broad and cultural, but the kind of work required to teach pupils to read successfully is quite in keeping with school conditions. Moreover, the ability to read a language is more likely to be of permanent practical value than any conversational knowledge that might conceivably be gained in school classes.

METHOD. — Pronunciation. — The importance of teaching the foreign sounds correctly in the early weeks of the modern language course cannot be too strongly emphasized. The work should be largely upon an imitative and oral basis, the teacher acting as model. It is also important that he possess a working

knowledge of phonetics. This will insure the right attitude toward this element of the course, and enable him to diagnose and correct mistakes wherever imitation is insufficient as a guide. Whether the pupils themselves shall be taught phonetic terminology and the foreign sounds at first by means of transcribed texts is a moot question. There are good arguments both for and against, particularly when dealing with a language like French. In any case, it is fundamental that there should be abundant practice in hearing and uttering the sounds of the new language.

Oral Practice. — Although intelligent reading is the chief end sought, a great deal of attention ought to be given to work in hearing and speaking, because of their very positive value in classroom procedure. In general, emphasis upon the spoken word makes for greater flexibility in the treatment of the material. It is stimulating to both teacher and pupil. Imitation and repetition are fundamental means of acquiring a new language, and if oral exercises in the foreign tongue are employed with judgment, there is no kind of work which allows and suggests to the teacher greater abundance of repetition, and hence tends to make right associations habitual. Moreover, the constant use of the foreign language in the classroom, in the form of commands and well-directed questions and answers, favors the formation of a *Sprachgefühl*, or language sense, an indefinable though undoubtedly a potent factor in the acquisition of a foreign language. The amount of time to be devoted to work in speaking cannot readily be determined. In general, however, practice seems to favor greater emphasis proportionally during the elementary stage, at a time when a great deal of drill is necessary to acquire the grammatical forms and a working vocabulary. But throughout the course it should be the rule to have regular oral practice carefully graded and coördinated with all other elements of the course. Only in this way can we be assured that it shall be beneficial in the work. The scope of work in speaking and its distribu-

tion in the different years of the course, its relation to other elements such as reading and grammar, have not as yet been satisfactorily worked out, particularly for the later stages. Adequate books and specially trained teachers are still lacking.

The earliest material will probably be best selected from objects in the immediate environment; and wall pictures, if judiciously employed, will be of great assistance in planning the elementary work. The bulk of the material for the secondary school, however, should be chosen from connected reading-texts. In the elementary stages these will consist of simple, constructed texts or natural texts that are rich in certain grammatical forms or vocabulary. Later the regular annotated stories, etc., may be made the basis for conversational practice. Still, for many reasons, chief among which are that the reading texts may not lend themselves to conversational treatment, that the vocabulary may be too uncommon or too highly literary in character, and above all that the selections may be too difficult, it would seem advisable on the whole to have separate texts for conversational practice, carefully organized as regards vocabulary, content, and form. Graded material dealing with foreign life and customs is suggested.

Work in speaking may be roughly divided into two kinds: (1) highly formal in character, (2) a more natural kind, which emphasizes the thought as well as the form side of the material. The first kind will consist of various changes in the sentences read, in person, number, tense, voice of the verb, and substitutions of pronoun for noun, etc. Questions may be put in such a way as to force the pupil to employ the desired grammatical form. The second type will consist largely of rapid questions and answers upon the day's reading. In the earlier stages the questions and answers would closely follow the printed text, later the text might be used merely as a starting point for conversational practice, the pupils drawing their answers from their general knowledge of the spoken language. From time to time the class would be encouraged to relate

the contents of a part or the whole of the material thus intensively studied. Success, however, in the later stages depends upon the thoroughness with which the so-called question and answer work is done. In any high school course simple questioning on a suitable connected text should occupy the major portion of the time in oral practice. It is only in this way that fluency and the requisite accuracy are assured.

Grammar. — Whatever other value the study of grammar may have in the mental training of the pupil, its immediate value is to enable him to acquire the foreign language on the form side systematically and intelligently. Only essential forms and usages should be selected, and these should be taught by constant practice rather than by drill upon rules. Correct habits of use should be regarded as of more importance than the mere learning of paradigms. In general, the treatment of grammar should be inductive at least in spirit. Traditional grammar teaching regards the translation of a number of detached sentences from and into the mother tongue as the chief exercise for clinching the previously studied formal rules. More recent teaching, however, lays great stress upon exercises planned to give a great deal of oral and written practice carried on in the foreign language itself. Some of these exercises have been suggested under the preceding topic, such as changes of tense, number and person, etc., based upon disconnected sentences or connected reading material. The filling out of appropriate endings and a large variety of exercises all serve to give more copious and quicker drill than the older translation method. Of greater importance than these, however, are the more or less formal question and answer drills, in which the teacher's questions force the pupil to employ the new grammatical principle or form. Many of these questions will be type questions, that is, one question will admit of a comparatively large number of answers, each one of which, however, will contain the required principle or form. The judicious employment of this so-called living grammar teach-

ing is of great advantage in giving quick, definite, and withal interesting drills which to a large extent are wanting under the still widely prevailing plan of translating detached sentences into the foreign tongue.

In a course lasting four years it seems highly desirable, in German at least, to have the first grammatical course extend over two years. The last two years might then be spent in giving richer practice and somewhat broader treatment. This plan, however, is not practiced in the majority of schools, with the result that pupils in the higher classes are often weak both in knowledge of forms and in the ability to use them accurately for the expression of simple thoughts in the foreign language.

Written Work. — Work in writing should accompany at every step the oral work in the German classroom. As a rule, it should follow directly the oral development of, and drill upon, the grammatical topic. After the material has been first threshed out orally in the classroom, it should then be put into writing, for the time being the final form. As not everything can be written, the work should represent that which is typical and essential in the lesson or series of lessons. The results obtained from writing are fairly obvious. Hand and eye serve to fix the oral impressions, and it checks up the work on a given topic. Further, it makes for greater definiteness and flexibility in the work done outside of class. In the early stages, however, it is better to have much of the written work done in class, and thus controlled and corrected at every step. But wherever done it is a wise procedure to ask of pupils that they shall employ in their written exercises only the materials, vocabulary, and principles, with which they are quite familiar through previous study.

Work in writing may be of two kinds: (1) exercises largely imitative in character, (2) exercises in translation, involving comparison between the mother and the foreign tongue. The latter type is still largely employed in all stages of the course.

Recently, however, teachers have found that written exercises, similar to, and in fact growing out of, the conversational practice, are productive of better results. In addition to the more formal exercises which emphasize a certain grammatical fact, the simple narrative of the day's lesson, and the introduction in the upper classes of the letter form of composition, offer a rich field for development. Over against this rather modern procedure, we find a large proportion of teachers still faithful to exercises in translating from the mother tongue into the foreign. In the early stages the exercises consist of detached sentences arranged under the appropriate grammatical headlines in the textbook. Later, a graded composition book, containing various styles of writing, is employed. As this kind of work prevails, often to the exclusion or at least the fitful use of free reproduction and other non-translation kinds of exercises, it is well to point out some of the weaknesses of the practice. (1) Pupils are made to learn the foreign language by comparison before they have sufficient knowledge of its vocabulary and principles. (2) The composition books are far too ambitious in character. The acquisition of speed and accuracy should be regarded more highly than the ability to translate difficult material inadequately. Written work of all kinds ought to consist largely of material that the pupil can readily do at sight.

Reading. — Since reading is the chief aim of the modern language course, great care should be exercised not only in the selection, but also in the treatment of the material. It should be interesting, possess literary merit, and be well graded as to difficulty and the maturity of the pupils. At present, the general tendency is to read stories, and in the later years some poems and plays of classical writers. Unity and point of view are lacking in the course. It is organized only as to general amount and difficulty required for entrance to college. It would seem desirable to increase the kind of reading dealing with facts, particularly with those that give

an insight into the life, customs, and history of the foreign peoples. In a four-year German course we might, for example, group the reading material around some definite points such as these: first year, a general introduction to German life; second year, legends and sagas and the *Märchen*; third year, some few facts of history as illustrated by the lives of great personalities; fourth year, at least one literary masterpiece and brief sketches of the lives of such men as Goethe, Lessing, and Schiller.

The traditional treatment of reading is that of translation into the mother tongue. More recently systematic attempts have been made, notably in Germany, to reduce the amount of time spent upon this exercise and to increase the ability of the class to study and understand the foreign text without the aid of habitual translation. Clearness of understanding in the early stages is effected by selecting simple, objective material and teaching it by means of close questioning in the foreign tongue, explaining new words by the use of objects, pictures, or gesture, by opposites, by the study of word formation, by definition in the foreign language, or even by translating troublesome words and phrases. If the work is systematically done from the outset, translation may be limited largely to the more difficult passages, and the time usually devoted to it be employed in various exercises carried on within the language being taught. How much shall be translated is a question, however, which individual teachers will always have to decide for themselves. Length of course and the equipment of the teacher are the controlling factors. It is obvious that translation is the quickest apparent test of the pupil's understanding of a passage, although where it is used to the exclusion of all other exercises upon the text, some of its weaknesses may be summed up as follows.

In general, translation is largely an exercise in the use of the mother tongue. As an exercise for teaching the foreign language, it is wasteful of time as a vocabulary builder.

Since the pupil exchanges symbol for symbol, it neglects almost wholly the acquisition of the form side of the foreign language, and as usually carried on, it lays but little stress upon the thought side. It has little or no influence upon the growth of language sense (*Sprachgefühl*). The foreign language is kept in the background, and is used as a mere vehicle for exercising the mother tongue.

RESULTS OF SCHOOL WORK.—What, briefly, should be the outcome of a four-year high school course in modern languages? The pupils should be able to read ordinary prose or poetry suitable in range of thought to their years of understanding. By far the greater proportion of the materials should be selected from modern authors. While there can be no objection to the appreciative study by the pupils of one or two of the classic dramas or other forms of literature, the reading of the classics in general should be deferred to the college period of modern language instruction. By the selection of reading material and by all other means that the teacher can devise, the pupils should have been taught some elementary facts regarding the life and customs of the foreign peoples. They should have obtained by careful teaching an accurate working knowledge of the essentials of grammar in order that their growth in knowledge of the language shall always be upon a solid foundation. In addition, the pupils should have acquired the power to use a small stock of common words in speaking or in writing. They ought, for example, to be able to answer questions based upon an easy story read to them, or to give its contents in simple language either orally or in writing. Finally, they ought to have some facility in conversing about simple matters of daily life and be able to express their doings in letter form.

PLACE OF MODERN LANGUAGES IN THE CURRICULUM.—The study of modern languages in the schools was largely developed during the nineteenth century. Before that period school instruction was not very widespread, nor were

the foreign languages given anything but a very minor place in the school program.

United States. *In Colleges.*— Until the Revolutionary war, American colleges, as a rule, followed about the same course of study as was found in the universities of the mother country. Latin and Greek, Hebrew, some logic and philosophy, rhetoric, elementary mathematics, and physics were regarded as ample. French is recorded as an extra study about the middle of the century at Harvard. The first professorship of French seems to have been established at the College of William and Mary in 1779, with the radical reorganization of the curriculum brought about by Thomas Jefferson. Students at Harvard, not preparing for the ministry, could substitute French for Hebrew in the 80's of the eighteenth century. But for a good many years the advance made by French and, later, German, in the colleges was extremely slow. It was an extra subject, occupying an inferior position in the same list as music, fencing, etc., to be paid for extra, and not permitted to interfere with the stated academic duties. George Ticknor was made Professor of French, Spanish, and Belles Lettres at Harvard in 1816. With his name is closely associated the term "elective system," which much later came to play such a rôle in the organization of the work of all higher education in America. The modern languages acted as the first entering wedge in the attempt at breaking up the rigid curriculum of the past. In 1825 the University of Virginia opened its doors, and modern languages formed one of the ten schools comprised in the plan. In six months the modern language school was second in numbers after mathematics, and larger than the school of ancient languages.

Very little progress in modern language studies was then made for over a generation until, in fact, the idea of elective studies again rapidly spread during the period of the presidency of Charles W. Eliot at Harvard. At present, the modern

languages are among the largest departments in the Colleges of Arts.

College Entrance Requirements. — If the development in the colleges was so slow, the condition in secondary schools is readily understood. It was not until 1875 that a modern language was required for admission to college.

At the present time many colleges demand a reading knowledge of French or German, or both, for the several degrees, although there is nothing like uniformity except in colleges exclusively for women. As late as 1896-1897, of 432 institutions only 14 per cent required a modern language for the B.A. degree; of 123 institutions 41 $\frac{2}{5}$ per cent required a modern language for the Bachelor of Philosophy, the modern language being in lieu of Greek. Similar percentages are shown in the requirements for the degrees of B.S. and B.L. In the same year only 123 out of 318 colleges and scientific schools required a modern language for admission.

Reports on the Secondary Curriculum and Methods. — The *Report*, published in 1899, of the Committee of Twelve, appointed by the Modern Language Association, has been of great assistance in fixing standards of modern language instruction in the schools. The method favored by the committee was on the whole the so-called reading method; that is, copious reading of graded texts, hand in hand with the study of grammatical essentials. But the committee also advised, particularly in the longer courses, the introduction of some oral work, and other practices of the German direct method. Three grades of attainments were defined in the *Report*, and reading texts for each suggested. The elementary grade, reached normally after two years of study, represents the minimum requirement now usually set for entrance to college. The work of the two higher grades, the intermediate and the advanced, is intended to take one and two years' longer study than the elementary. The Committee's *Report* was early adopted by the College Entrance Examination

Board and the combined influence has done much to bring about unity in admission requirements. The aim of instruction and the work to be done in the various grades is about as follows:

For the elementary course. Ability to translate at sight very easy dialogue or narrative prose, to put into the foreign language short English sentences taken from the language of everyday life or based upon a text given for translation, and to answer questions upon the rudiments of grammar. The committee suggested that the amount of reading to be done should, in French, consist of 350 to 375 pages; in German, of 225 to 250 pages. In addition to careful drill upon pronunciation, abundant easy exercises of various kinds should serve to fix the essentials of grammar and to cultivate readiness in the reproduction of natural forms of expression.

For the intermediate course. Ability to read at sight prose of ordinary difficulty, to put into the foreign language a connected passage of simple English based upon the text read, and to answer more difficult grammatical questions. The work to be done in reading should consist of about 400 to 600 pages of French, or 400 pages of German, with constant practice in giving paraphrases of portions of the matter read, together with more extended study of the grammar of the foreign language.

For the advanced course. Ability to read at sight difficult French not earlier than that of the seventeenth century, or any German literature of the past 150 years that is free from textual difficulties, to put into the foreign language a passage of simple English prose, to answer German questions relating to the lives and works of the great writers studied; in French, to carry on a simple conversation. The work of the last year should consist of about 600-1000 pages of standard French or of about 500 pages of German literature respectively. Pupils should also write numerous short themes as well as translations of English into the foreign language.

While the Report of the Committee of Twelve remains even to-day an excellent statement, on the whole, of the aims and methods of foreign language study, the experience of the past years warrants a restatement in regard to some particulars. Higher standards of thoroughness, greater intensity and variety in the treatment of the material make it impossible to cover satisfactorily the number of pages indicated in the report. This is particularly true with regard to the intermediate and advanced grades. The reading lists also require adjustment and more careful standardization for the various grades. The rate of advance in difficulty from the elementary to the intermediate, and, again, from the latter to the advanced, is, undoubtedly, too great, and out of harmony with school conditions. Lastly, the importance of oral and aural training, of the freer use of the foreign language in general, would now be more greatly accentuated.

Within the past few years, the more progressive teachers, stimulated by the results obtained by the reformers in Germany, have been trying to adapt to local conditions some of the aims and methods employed abroad. More attention has been given to oral work, and to teaching pupils freer and better control of the language in general. The greatest obstacle to rapid progress, however, is bad teaching, for outside the large city systems there are far too few special teachers possessing adequate knowledge of the subject, and specially trained in methods of presentation.

Distribution of Pupils. — The geographical distribution of pupils studying French and German in secondary schools shows remarkable variations. In general, the North Atlantic Division leads in the percentage of pupils studying both French and German in 1909-1910, with 27.56 per cent as against 11.50 per cent for the rest of the United States. Again, the New England states lead in the percentage of those pursuing French, with 41.21 per cent as against 6.44 per cent for the rest of the United States. On the other hand, the

same states are below the average for the United States in the percentage of pupils studying German, 17.21 per cent as against 23.69 per cent for the country as a whole. As an example, also, of the great variation in the study of the two languages in different states, 49.09 per cent of pupils in the New Hampshire secondary schools study French as against 0.69 per cent in Indiana. New Jersey leads in percentage of pupils pursuing German, with 41.39 per cent, while the percentages for South Carolina, Louisiana, and Mississippi are 0.34 per cent, 0.72 per cent, and 1.69 per cent respectively.

Germany. — Although Germany was much in advance of other countries, the introduction of French into the schools did not begin to make any headway until the eighteenth century. Before that time its study was confined to private instruction or to the schools attended by the upper classes (*Ritterakademien*). By the beginning of the nineteenth century, however, most Prussian *Gymnasien* offered French as an optional subject. Owing to patriotic reasons, it was banished from the schools in 1816, to be taken up more vigorously a few years later. In 1831 French became obligatory in Prussia, beginning in *Tertia*. Other states followed later, Saxony in 1846, Bavaria in 1854. The study of English was much slower in its development. The relations between the countries were in earlier times not strong, but were kept alive by trade, traveling, and, notably, beginning with the middle of the eighteenth century, by the increased interest in English literature. It was, however, not until as late as 1859 that English was made obligatory in the *Realschulen* of Prussia, although of course it had been gradually introduced in the schools during the first half of the century. Since the refounding of the German Empire, and particularly during the last two decades, the study of English has made rapid advances. In 1900 an imperial edict allowed the substitution of English for French in the three upper classes of the gymnasium (OII, UI, and OI), French remaining an optional subject. It also made

possible the substitution of other subjects for Greek in *Untertertia*, *Obertertia*, and *Untersekunda*, in which case three of the six hours are given to English, and the other three are distributed among French and mathematics and the sciences.

Method. — The method of modern language instruction in Germany has, from early times, swung between two poles, — the synthetic and the analytic. Both types of instruction have existed at all times side by side, although, during the first half of the nineteenth century, the method employed in the schools was on the whole synthetic and a close imitation of the severely grammatical procedure employed in the teaching of Latin and Greek. This was due in part to a great lack of properly trained teachers, for the universities were late in establishing chairs of French and English, the majority coming after 1850. The new facilities for study produced in time an organized and well-schooled body of modern language teachers. Particularly during the last generation have great changes been made, bringing progress toward better ways and means of teaching the subject, so that at the present time no other country equals Germany in the excellence of its modern language instruction. The method now widely employed, often called the direct method, is analytic in character, and is a revolt against the older formal grammatical procedure. The chief points are as follows: Reading occupies a central position in the work in place of grammar, and is selected so as to give pupils a clear idea of the life, thought, and civilization of the foreign people. In all stages, but particularly in the earlier, great emphasis is laid upon oral practice. Indeed, the emphasis upon the spoken language and upon written exercises growing out of the oral work is a salient characteristic of the method. Translations from and into the vernacular cease to be any longer a regular exercise. Grammar study is reduced to essentials, and taught largely inductively. This, in general, represents the plan of the more radical reformers.

FRENCH INSTRUCTION IN PRUSSIAN SCHOOLS

	VI	V	IV	UIII	OIII	UII	OII	UI	OI	TOTAL
Gymnasium	—	—	4	2	2	3	3	3	3	20
Realgymnasium	—	—	5	4	4	4	4	4	4	29
Oberrealschule	6	6	6	6	5	4	4	4	4	47
Realschule	6	6	6	6	6	5	—	—	—	35
Reform Gymnasium and Reform Realgymnasium with common foundation	6	6	6	3	3	2	2	2	2	32
						4	4	3	4	39

ENGLISH INSTRUCTION IN PRUSSIAN SCHOOLS

	IX	VIII	VII	VI	V	IV	III	II	I	TOTAL
Gymnasium	—	—	—	—	—	—	—	2 ¹	2	6
Realgymnasium	—	—	—	3	3	3	3	3	3	18
Oberrealschule	—	—	—	5	4	4	4	4	4	25
Realschule	—	—	—	5	4	4	—	—	—	13
Reform Gymnasium and Reform Realgymnasium with common foundation	—	—	—	—	—	—	2 ¹	2	2	6
						6	4	4	3	17
GIRLS' HIGHER SCHOOL	X		VII	VI	V	IV	III	II	I	TOTAL
French	—	—	6	5	5	4	4	4	4	32
English	—	—	—	—	—	4	4	4	4	16

¹ Optional.

The more conservative, forming probably the majority, still favor the retention of translation, and greater emphasis upon the grammatical course.

The work, particularly of the more advanced reformers, has been the subject of much criticism, especially in the last decade, partly because of its too utilitarian tendencies, and partly because of the general instability of pupils' knowledge, mainly on the formal side. The movement, however, represents a great step forward in both aim and practice. Modern language method has never before been so efficiently and rationally organized with the idea of giving power to the pupil to use the foreign language in reading, in writing, and in speaking.

France. — German and English are the modern languages most studied in the French public schools, instruction in Spanish and Italian being confined almost exclusively to places near the borders of the respective countries. Of the two languages German is chosen more frequently in the boys' schools. This is partly due to the fact that it is required for entrance to the military school at Saint-Cyr and the *École Polytechnique*. English is more favored in the girls' schools.

Instruction in the modern languages was made optional in *lycées* and colleges in 1821, though but little weight was attached to their study, and but meager time allowed. In 1838 the study became compulsory in the classical course, and in 1847 in the "modern" course. In 1880 modern languages were studied in every class, with a total of twenty-nine hours per week. The kind of instruction, and the results obtained, were, however, unsatisfactory. Translation from and into the foreign tongue, and much formal grammar were the chief means employed almost everywhere, even as late as 1896, although the ministerial instructions of 1890 were in theory in advance of any of the German official regulations of about the same time. The provinces in particular were very backward. The reform, which had already been in

progress a dozen years or more in Germany, had as yet made scarcely any impression upon the work in France. In 1902, however, the whole subject of modern language instruction was radically changed. The aims and practices of the advanced German reformers were taken over, stock and barrel, and formulated in the instructions of the 15th November, 1901. Since that time most earnest attempts have been made by the government and the teachers to carry out the new radical program, and apparently with considerable success.

After six years' trial it was found necessary to be more conservative in the work, particularly in the upper classes. The new instructions of 1908 confirm and strengthen the plan of work done in the lower classes. For the fifth and fourth classes translation into the mother tongue, not mentioned in the earlier instructions, is suggested as a means of control in addition to the study of the reading text by exercises in the foreign language. The chief changes, however, are made in the instructions dealing with the work of the second and first classes. The earlier program emphasized reading material dealing with the life, civilization, and history of the literature of the foreign people; the new lays stress entirely upon literature, pure and simple. Moreover, one of the chief exercises of the last period is the cultivation of the art of translation into the mother tongue. These changes, however, are very slight on the whole. France leads the world, officially, in the advocacy of the radical direct method of modern language teaching.

Modern languages may now be studied for eleven of the twelve years in the French *lycées* and colleges for boys. In the second year of the preparatory division and in the eighth and seventh forms of the elementary division the subject is very inadequately represented by two hours for each. Attempts to eliminate the study and to defer the regular instruction until the sixth form have thus far failed. In the following four forms, constituting the first cycle, one modern lan-

guage is studied five hours per week in each of the four years. In the first two forms of the second cycle the number of hours devoted to modern languages depends upon which of the four possible groups of courses or sections the pupil elects to pursue. The following is a table for these two years :

	SECTION A	SECTION B	SECTION C	SECTION D
	Latin and Greek	Latin and Modern Language	Latin and Science	Science and Modern Language
Modern Language	2	3 4 ¹	2	3 4 ¹

In the highest form there is a twofold division into the philosophy and mathematics forms, each with two sections, A and B.

	PHILOSOPHY		MATHEMATICS	
	Section A	Section B	Section A	Section B
Modern Languages	2 ²	{ 1 2 ³ }	2	{ 1 2 ³ }

The modern language course in girls' secondary schools is begun in the infant class and continued as an obligatory study throughout all the nine years. In the last two years a second modern language may be taken. The following is the number of hours per week in each of the classes: $2\frac{1}{2}$, $2\frac{1}{2}$, $2\frac{1}{2}$, $2\frac{1}{2}$, 3, 3, 3, (2),⁴ 3 (2).⁴

The following is the number of hours given to modern languages in the usual three classes of the French higher

¹ Second language begun and continued.

² Optional.

³ Pupils have the right as to distribution of these hours.

⁴ Second language optional.

elementary schools, the *écoles primaires supérieures* and *écoles pratiques de commerce et d'industrie*.

BOYS' SCHOOLS	I	II	III
General Course	3	3	2
Commercial Course } <i>école supérieure</i>		4	4
Commercial Course (<i>école pratique</i>)		6	6
GIRLS' SCHOOLS			
General Course (<i>école supérieure</i>)	3	3	3
Commercial Course (<i>école pratique</i>)	4½	4½	4½

England. — The status of modern foreign languages in English schools of secondary grade is still in the making. Among the factors that have retarded their growth are:— (1) Lack of any national system of public instruction before 1902; (2) The influence of the older universities and public schools — strong bulwarks of classical training; (3) Until a few years ago, the overemphasis of science and art subjects in non-endowed schools, in order to obtain state grants of money, and the consequent neglect of the humanities; (4) The attitude of the Board of Education towards modern languages, its insistence upon Latin as one of the two foreign languages taught in every school. In the most recent circular, however, it has taken a more liberal attitude and has yielded so far as to say that provision for the study of Latin need not be made in every school, but only in one out of every group of schools. The present ratio of pupils taking French to those taking German is about five to one. Since it is usually possible for pupils to take only two foreign languages of which Latin either must be, or almost invariably is, one, German goes to the wall. Indeed many feel it is in a state of serious decline.

According to the *Report* on the conditions of modern language teaching presented in 1908 at the meeting of the Modern Language Association, the average age of pupils beginning

French was 11; of 98 schools of the local type reporting, 74 began French first, 4 schools Latin, and 20 began the two languages simultaneously. German, if studied at all, is taken up at 14. This gives little time to the study of this language where the leaving age is 16 or 17. Four or five 45-minute lessons a week are quite usual for the foreign language.

The teaching has shown great improvement in recent years. In the past, particularly in the public schools and the numerous private schools, the scanty instruction was in the hands of a foreigner who was, far too often, treated as an outsider in the social scheme. To-day there are an increasing number of men and women — trained at the universities or by study abroad — who have done much to put modern language work in a better strategic position. Within the past ten years or so, the principles of the German reform method have found many advocates. The Modern Language Association with its excellent organ, *Modern Language Teaching*, has been a powerful instrument in arousing apathetic official boards and in creating public interest in the cause, and, particularly, in threshing out and adapting the so-called "direct method" to English conditions. Judging from the report of the committee referred to above, reform teaching has already made considerable headway, especially in the elementary stages of instruction. The various university and other examining bodies that play such a rôle in English education have also begun to set papers more in keeping with modern aims of foreign language teaching.

TOPICS FOR FURTHER STUDY

1. The range of active vocabulary in the modern language course.
2. The use of illustrative material.
3. The use of the talking machine.
4. The organization of reviews.
5. The applications of the Gouin method.
6. The relation between class and home work.
7. The study of typical errors of pupils.

8. Prescribed reading for entrance to college.
9. Examination papers as a test of power and of knowledge.
10. The organization of drill exercises.
11. The use of the mother tongue in foreign language instruction.
12. The teaching of grammar in the foreign language.
13. The relation between speaking and reading in the higher stages of the course.
14. The aim and organization of written work in the higher stages.
15. The acquisition of the foreign language vocabulary.

REFERENCES

- BAGSTER-COLLINS, E. W. *The Teaching of German in Secondary Schools*. New York, 1904.
- BAHLSSEN, L. *The Teaching of Modern Languages*. Boston, 1905.
- BAUMANN, F. *Reform und Antireform im neusprachlichen Unterricht*. Berlin, 1902.
- BREUL, K. *The Teaching of Modern Foreign Languages*. London, 1908.
- BÜTTNER, H. *Die Muttersprache im neusprachlichen Unterricht*. Marburg, 1910.
- EGGERT, B. *Der psychologische Zusammenhang in der Didaktik des neusprachlichen Reformunterrichts*. Berlin, 1904.
- England, Board of Education. *Special Reports on Educational Subjects*, Vol. II (1898), pp. 648-679; *Teaching of Modern Languages in Belgium and Holland*, Vol. III (1898), pp. 461-533; *Teaching of Modern Languages in Germany* (several articles).
- FLAGSTAD, CHR. B. *Psychologie der Sprachpädagogik*. Leipzig, 1913.
- HANDSCHIN, C. H. *The Teaching of Modern Languages in the United States*. Washington, 1913.
- HOVELAQUE, E. *Deux Conférences sur l'Enseignement des Langues Vivantes*. Paris, 1910.
- JESPERSEN, P. *How to Teach a Foreign Language*. New York, 1904.
- MÜNCH, W. *Didaktik und Methodik des französischen Unterrichts*. München, 1910.
- QUIEHL, K. *Französische Aussprache und Sprachfertigkeit*. Marburg, 1906.
- Report of Committee on Modern Languages*. Washington, 1899, also Boston.
- WALTER, M. *Englisch nach dem Frankfurter Reformplan*. Marburg, 1910.
- Zur Methodik des neusprachlichen Unterrichts*. Marburg, 1908.

WOHLFEIL, P. *Der Kampf um die neusprachliche Unterrichtsmethode.*
Frankfurt, 1901.

WOLFROMM, A. *La Question des Méthodes. Revue de l'Enseignement
des Langues vivantes.* Paris 1902-1905.

Periodicals : —

Die Neueren Sprachen. Marburg.

Modern Language Notes. Baltimore.

Modern Language Teaching. London.

Monatshefte für deutsche Sprache und Pädagogik. Milwaukee.

Revue de l'Enseignement des Langues vivantes. Paris.

Zeitschrift für französischen und englischen Unterricht. Berlin.

CHAPTER XII

THE NATURAL SCIENCES

EDUCATIONAL FUNCTIONS AND VALUES OF THE SCIENCES

WHAT SCIENTIFIC STUDY SHOULD DO FOR THE PUPILS. — Educational values of great importance may be derived from the study of science, if it be taught in accordance with the scientific method and from the broad, humanistic viewpoint. The extent to which these values are likely to be realized will depend on the natural tastes and aptitudes of the pupils, their previous and their present environment, their present powers and abilities, and the degree of perfection attained in the methods by which they are taught. Certainly these values are more likely to be realized in the pupils if the teacher understands them. They are therefore here enumerated and will be briefly discussed.¹

1. The formation of some useful specific habits, — through training, routine, rationalized practice.

2. The acquisition of useful information, — through methodical study, instruction, and drill.

3. The adoption of valuable ideals, or “emotionalized standards,” — inculcated through the inspiration to be gained from the teacher, from the lives of great scientists, and from experiences of intimate contact with nature.

4. The acquisition of facility in the use of facts, ideas, and methodical thought processes, for the solution of problems.²

¹ Cf. Bagley, W. C., *Educational Values*. New York, 1911, Chap. VII.

² In this chapter the word problem is to be taken in its broadest sense, meaning any situation involving doubt, in which thinking is required in order to reach a solution. Cf. Dewey, John, *How We Think*. Heath & Co. Boston, 1910, p. 9.

the overcoming of difficulties, and the accomplishment of worthy purposes, — through the mental discipline afforded by properly graded practice in the solving of scientific problems.

5. The development of taste, and power of appreciation, — to be gained through a clear apprehension of unity, adaptation, economy, order, and system in nature as interpreted by science.

6. The development of scientific or philosophic insights, perspectives, and attitudes of mind that serve as safeguards to the intelligent interpretation of contemporary life, — through acquaintance with systems of organized knowledge.

Thus science teaching has a training function in the formation of right habits, an instructional function in the storing up of useful information, an inspirational function aiming at the inculcation of worthy ideals, a disciplinary function, resulting in the development of mental power, a recreative function, tending toward the development of refined tastes and powers of appreciation, and an interpretive function, aiming at scientific insight, and such broad mental perspectives as are characteristic of a cultivated, well-balanced mind.

The general aim of education from the modern standpoint is the development, in each individual, of the highest type of personality, combined with economic and social efficiency. This aim takes account of individual differences and environmental differences. Its motto is "The socially efficient individual."

On this basis the hope for outcome of the training function is the realization of utilitarian, economic, or vocational values, — "bread-and-butter values," so to speak — which contribute to the ability of the individual to support himself and a family. In the more narrowly vocational studies and trade studies, the aim is toward direct utilitarian value, — the specific kinds of motor skill needed in particular occupations, such as carpentry, electrical construction, plumbing, cooking, and the like; but the habits formed in science study are more indirect, more varied, and therefore of more general application. If the usefulness of these habits in life situations outside the

school are clearly shown, so that the pupils realize their value as permanent acquisitions that will help them in their everyday lives in definitely apprehended ways, the pupils may form ideals of carrying these habits over into their everyday lives. Experiments have shown that, without such conscious ideals, such habits are not at all likely to be carried over in large measure.¹

The instructional function tends toward utilitarian value, and also toward preparatory value. Much of the information gained in the study of physics, chemistry, botany, geology, and zoölogy is necessary in preparing for the higher studies needed in the professions of applied science, such as engineering, scientific agriculture, teaching, and medicine.

Both the training and the instructional function result incidentally in a certain amount of conventional value. Through these functions the pupil may acquire some of the habits, manners, and general information which constitute that minimum of conventional culture, without which society will refuse to accord him respect, and the lack of which would stamp him as a boor, an ignoramus, and make it less easy for him to get on harmoniously with his fellows.

The remaining functions contribute to socializing value, because they enable the individual who has profited by them to contribute to social progress. They fit him to be a "soldier of the common good," to help in increasing the achievement of each for all and all for each, through the improvement of the environment of all and the personal worth of each.

Specific Habits. — The following are some of the specific habits which pupils will tend to acquire through the study of any of the sciences under the direction of a good teacher. Since they are of kinds that will be useful in very many of

¹ Cf. Rowe, S. H., *Habit Formation and the Science of Teaching*. Longmans, Green & Co., New York, 1910, Chap. XII, especially pp. 243 ff.; Colvin, S. S., *The Learning Process*. Macmillan, New York, 1911, pp. 220 ff.; and Thorndike, E. L., *The Psychology of Learning*. Teachers College, Columbia University, New York, 1913, pp. 415 ff.

the situations of everyday life and in all kinds of occupations, they are of great general utility, and are important to every individual. While the time and attention given them should not be allowed to become disproportionately great, no teacher should allow himself wholly to neglect them.

1. Careful observation of significant facts and phenomena, using hands, eyes, and ears before consulting books.

2. System, order, and neatness in the arrangement of apparatus and appliances for observational and experimental work.

3. Carefulness and skill in the manipulation of tools and appliances.

4. Careful measurements, according to correct methods.

5. Accuracy and methodical procedure in setting down, arranging, and tabulating data, and in making calculations.

6. Legible writing, clear, neat and accurate drawing, correct spelling and punctuation, correct grammatical construction, clearness and conciseness in written and spoken English.

7. Good form and effective motor attitudes and expression in "making a recitation."

In the routine of studying a science in school all the various kinds of acts implied by the list just enumerated will be performed, either in the right ways or in wrong ways. Whenever an act or a thought occurs in response to a question, direction, suggestion, or act of the teacher, and it results in satisfaction, it is likely to be repeated under the same stimulus or a similar one. Every repetition of such a motor reaction or mental connection tends to make it recur automatically. Hence, habits of some sort will inevitably be formed. Whether they are to be right habits or wrong habits will depend on the way in which the teacher conducts the work.

The Law of Habit Formation. — This is a special case of the more general law of mental connections or association, and is stated by Thorndike¹ as follows: "The likelihood that

¹Thorndike, E. L., *Elements of Psychology*. A. G. Seiler, New York, 1905, p. 207.

any mental state or act will occur in response to any situation is in proportion to the frequency, recency, intensity, and resultant satisfaction of its connection with that situation or some part of it, and with the total frame of mind in which the situation is felt."

Application of the Law of Association in Teaching. — Hence the teacher should see to it, when any of the things above referred to are done, that (1) the pupils clearly understand what is the best way and why it is best, (2) that he arouses in them such ideals of good form, efficiency, and professional pride, and gets them into such a total frame of mind that they shall be anxious to do it in the best way, (3) that in the inevitable repetitions of the act they are not allowed to lapse into wrong ways, but are made to do it in the right way every time, and (4) that satisfaction shall always be connected with the right way and dissatisfaction with the wrong way until the right way becomes automatic.

Scientific Information. — The content of the sciences is made up of facts, phenomena and processes, laws and principles, hypotheses and theories, and fundamental generalizations, arranged and classified in accordance with their relations to one another, — particular under general, and these in turn under more general. The relations in accordance with which they are classified have to do with time, space, quality, — especially with reference to function, or use, quantity, and cause, origin, or development.¹

The Choice of Subject Matter. — There are three conditions under which any part of the content or subject matter of a school study may be made permanently useful.

¹ Economy of space forbids elaboration of this topic. To the reader who has pursued extended courses in one or more of the sciences its meaning will probably be clear, as the classification and arrangement of the content of most science textbooks are made from the logical rather than the psychological point of view. No better illustrative examples of the kinds of content and modes of organization of scientific subject matter for the purposes of the mature scholar can be found than the article on "Science," and the articles on the special sciences in the *Encyclopædia Britannica*.

1. It must be capable of being made simple enough to be clearly comprehended by the pupil ;
2. It must be knowledge that will help in the accomplishment of some worthy purpose ;
3. It must be frequently associated with the situations in which it is likely to be needed, or some part of them, or something like them, so that it can be recalled when the need for it occurs.

Were these three conditions always applied as criteria in the selection and teaching of the subject matter, much uninteresting and worthless lumber that is handed down from textbooks of an earlier day would be discarded from our lessons. Actual utility of this sort ought to be the sole test for the choice of subject matter, since there are such vast stores to choose from that no one can possibly learn it all, even should he so desire. To defend subject matter that cannot stand these tests by claiming that it is a means of mental discipline — of gaining power — is to ignore the findings of modern psychology. So far as mental power is dependent on information, it consists precisely in having at command, for immediate recall and use, information that will help to solve the various problems of everyday life, intellectual and social as well as physical, and especially such problems as have elements of more than ordinary novelty and difficulty in them. To claim that mental power results from the mere acquiring of information that cannot be so used is a direct contradiction of terms. On the other hand, even though the learning of contentless material were granted disciplinary value, there is a superabundance of useful material out of which just as good discipline can be got, provided the methods by which it is imparted are right.

Criteria for the Choice of Subject Matter. — In making choice of content we should select that which is comprehensible, and which has the greatest number of useful elements in common with the present everyday-life situations, interests, and knowledge of the pupils, and with the everyday-life situations in which

they may reasonably be expected to take part when they become adults. Since the law of efficient recall is identical with the law of habit formation, we should connect this content with as many as possible of these situations, and do it as frequently, as vividly, and as interestingly as possible.¹ It is thus only that we can make sure that the knowledge gained shall be of useful sort, and that it shall be usable.

The Mastery of Content. — Much of the content of the sciences is familiar to the active and enterprising boy or girl, but his concepts, gained empirically through untrained experience, are vague. The meanings grouped in them are disconnected and unsystematized. Such vague, indefinite products of experience are called psychological concepts. The teacher's problem is to start with what the pupil knows about a fact or law, — with his psychological concept, — and help him to work out his ideas, to make them clear and explicit, to apprehend their relations, and to classify and arrange them accordingly. He must be supplied with new meanings from various sources, and in various ways, so that the content of his concepts may be enlarged. He must be taught to define his concepts, and connect them in memory with the names, symbols, formulæ, definitions, or statements that are to stand for them. By such a process his vague psychological concept of tree, or mountain, or plain, or the law of the lever, or of the process of stream erosion becomes an explicit, organized, logical concept, and is connected in memory with a word or definition which serves to recall any or all of the many clear and useful meanings that are now grouped in systematic order under it.²

The learning of facts and laws, the building up of concepts, the mastery of principles, are best carried on in connection with problems to the solution of which the knowledge is necessary or significant. The memory connections and associations thus

¹ See pp. 449 and 450 *ante*.

² See Miller, *The Psychology of Thinking*. Macmillan, New York, 1910, Chaps. XV and XVI.

made will be stronger just because of this necessity or significance; for if there is a strong desire or incentive toward reaching the solution, the information will be sought earnestly, it will be connected vividly with the other elements of the problem, and the connection will result in satisfaction if the knowledge proves to be helpful. Furthermore, frequency is secured by the repeated use of the fact or principle in different problems.

If an important principle is not successfully memorized in this way as an incident in problem solving, its utility may at least be made so apparent that the students will cheerfully submit to whatever formal drill may be necessary in order deliberately to memorize it for further use.

It thus appears that separate lessons will not often be necessary for the mastering of content and the mastering of method, but that the former is best acquired through the problem lesson, wherein lies the only road to a real hold on the latter.

Inspiration and Scientific Ideals.— Ideals constitute the motive power for human endeavor. This is true for the adolescent no less than for the adult. Adolescence is the very time when the tendency toward idealizing is strongest. What the youths or maidens choose to do, how they regulate their conduct, depends, so far as their personal initiative is concerned, on what they think worth while. Hence, the importance of recognizing the values of scientific ideals and of making every effort to realize them in the teaching process can hardly be overstated.

Scientific study if carried on in the true scientific spirit compels sincerity, out-and-out intellectual integrity, uncompromising honesty, at every step. "What are the actual facts?" "What is the truth about them?" These are the sole ultimate questions of scientific study. To know the truth and put it into usable form, is the only aim. Since honesty is of the very essence of scientific study, the student of science under good scientific instruction is trained day by day to habits of honesty, to the habit of seeking the truth, and he may therefore come to realize the general value in individual and social life, of sincerity,

honesty, and love for knowledge of reality for its own sake. He may without special direction analyze out and generalize these ideals from the daily practice of these virtues in classroom and laboratory. Now although it is fair to count on something in the way of their unconscious acquisition, yet great opportunities for immediate motivation and the determination of future character will be lost, unless the teacher constantly holds up the worthy ideals before the pupils, and occasionally points out their utility, both for accomplishing the scientific work immediately in hand, and for regulating the conduct of a successful life. In doing this the situations chosen as examples of such utility should always be specific and concrete, not general or abstract. Referring again to the law of mental connections, the teacher should understand that the only way to make sure that the ideal of honesty in the schoolroom be recalled and used in the various situations outside is to have the pupils associate it with a great variety of these situations with "frequency, vividness, and resultant satisfaction," and then to generalize it.

Prudish and abstract sermonizing is harmful. It defeats its own end; but if the teacher loves the ideal and lives it himself, he will find multitudes of tactful ways, in addition to the powerful way of example, for quietly influencing his pupils to adopt it deliberately as a rule of life.

Other important ideals that may be expected to accrue from the study of science by the scientific method are: (1) achievement, (2) industry, (3) "stick-to-itiveness," concentration of attention on the thing in hand, (4) efficiency, or accuracy combined with speed, (5) resourcefulness, (6) open-mindedness, (7) a logical, well-balanced mind, (8) hatred of narrowness and prejudice, (9) social service, and (10) the ability to present ideas clearly and convincingly.

Mental Discipline.¹ — Notwithstanding the specific character of habits and intellectual functions, the possibility of the transfer or spread of training into fields other than those in which it is

¹ Cf. Whipple, G. M., p. 300 ante.

acquired is admitted by most modern psychologists; but it is certain that the extent to which such transfer may spread depends very largely on the kind of content with which the training deals, and the way in which it is taught. Our present task is to find a principle that will help the teacher of science to convert this possibility into fact.

The so-called generalized habits, such as concentration of attention, methodical procedure, accuracy, open-mindedness, etc., are specific habits that can be used in a large number of different situations having elements of likeness to the situations involved in the training in which these habits have been gained, and requiring responses of a more or less similar kind.

Knowledge of many facts of physics, chemistry, geography, botany, etc., enables one to get on better in a great variety of activities in which knowledge that is identical with it, or like it, in whole or in part, is needed as a basis for ideas in the solution of difficulties, and the performance of tasks. It has been shown elsewhere¹ that the method by which the scientific worker controls his thinking and carries on his researches is only a refinement and perfection, through scientific training, of the methods of thinking that are used by everybody who thinks effectively. Thus it is evident that scientific training has elements of method that are common to all problematic situations in every field of activity.

Applying the Principles of Transfer. — Hence, in order to get general discipline out of any particular study, the content selected for teaching must be that which has the greatest number of such common elements, and these must be mentally associated with as many as may be of such activities, as frequently, vividly, and interestingly as possible.

Also whenever the methods used in the study are applied in whole or in part, with or without modification, to the solution of important problems or the performance of work important

¹ Cf. Dewey, *op. cit.*, Chap. VI, and Twiss, G. R., *The Principles of Science Teaching*. Macmillan, New York (in preparation), Chap. IV.

to the present or future life of the boys and girls, the teacher should make the pupils think how such methods apply, and what modifications, if any, must be made of them in order that they may be most efficiently used.

In connection with forming habits of connecting school knowledge with life problems, the advantage of habitually acquiring such knowledge and of using it for accomplishing worthy things must be shown, so that an ideal of so acquiring and using concepts and principles may be built up and emotionalized.

How Concepts of Method are Built Up.—The most important phase of teaching with respect to mental discipline is the formation of concepts of method. These are built up just as other concepts are. Through the experience gained in solving a large number of practical problems, the student becomes acquainted with certain modes of attack, methods of orderly procedure, ways of classifying data, and points of view in interpreting data, all of which are commonly found to be advantageous in handling such problems. He forms habits of analyzing problematic situations to find out the features of them that are essential or significant to their solutions. He acquires habits of forming hypotheses, reasoning out their implications, and testing these implications one by one by comparison with the actual facts through systematic observation or definitely planned experiments. He learns processes of weighing, measuring, testing, separating, of eliminating irrelevant circumstances, materials, or forces, of restricting inferences to what logically follows from known facts, of making card catalogues, looking up bibliographies, and the like. Through his experience with these methods and through appreciation of the value of methodical habits and definitely planned procedures, he gradually gets the idea that there is some kind of methodical procedure that is best for any given thing that has to be done, or any given kind of problem that has to be solved. Sooner or later he begins to observe, classify, and organize the methods which he has used, to find out in what kinds or classes of problems each one of these methods

is applicable. Thus he accumulates facts about methods, grasps the meanings of methods in their relation to various kinds of problematic situations, and learns what kinds of procedure are applicable in various kinds of problems. Bit by bit he adds these to his notion of what methodical procedure is, what it is good for, and how a well-known method of procedure must be modified in its details to fit new situations that are like old ones in general but different in some of their details. The extent to which his psychological concept of methodical procedure will be converted into a well-ordered and usable logical concept will depend very largely on the methods by which he is trained, and these in turn will depend on how broad and thorough is the teacher's concept of method, and how fertile he is in assisting the students to notice and classify methods as they go along, and how careful he is to have them notice situations, outside the schoolroom, to which these methods may be fitted either with or without modification.¹

Precepts for the Conduct of Transferable Training.— From the principles just stated we may derive some rules of procedure for the science teacher who wishes so to shape his methods of teaching that his pupils may get transferable discipline out of their study under his direction.

1. It is impossible to teach the whole of any science; therefore a most careful selection of subject matter and method must be made.

2. In making the selection the choice should fall on such elements of content and such elements of method as are useful in many situations of present-day life, and especially of the sorts of life that the pupils who are being taught are likely to live, now or later on.

3. The pupils should be caused to make association connections between these elements of content and method, as developed in classroom and laboratory, and the situations of life

¹ Cf. Heck, W. H., *Mental Discipline and Educational Values*. John Lane Co., New York, 1911, Chap. VI and VII. Also the authorities cited in the footnote, p. 448.

outside the schoolroom wherein such elements have significant counterparts.

4. Careful attention should be given to building up general concepts of method and ideals of methodical procedure for the conscious purpose of rendering the discipline transferable.

5. Whenever possible both subject matter and method should be presented by means of problems which are of such a nature that the pupils desire to attack and solve them for their own satisfaction rather than as perfunctory school tasks.

Developing Powers of Interpretation. — The interpretive value of science is closely related to the disciplinary value; and like this it is secured in very large measure by studying science according to the scientific method. The habits and ideals growing out of practice in organizing knowledge into systems, and practice in bringing particular cases and problematic situations under the general and special systems where in accordance with their relations they properly belong, are the fundamental elements of interpretive power. One who is trained in this way will know how and where to look for the facts in any case, and what kind of principles to apply in dealing intelligently with them. He will know whether the matter in hand is a case for observation and experimentation, or a case to be settled by an appeal to authority, or whether it is simply a matter that goes back to a definition. Problems of interpretation are largely problems of deduction from known definitions, principles, and laws; or they may be problems of explanation, — that is, of identifying facts as cases or consequences described by certain general principles or laws.

Such acquaintance with systems of knowledge also tends to give one broad points of view, and a judicial, open-minded attitude toward all questions. It gives him an appreciation of proportion, — of the relative importance of things, — and therefore enables him to gain such intellectual perspectives that his judgments on any question are likely to be good judgments, so far as he permits himself to judge. One so trained and cultured

will know also when his judgment is likely to be poor, and who the experts are whose judgment of the question is certain to be good. He will in such cases consult the experts and accept their conclusions instead of his own. For example, if he were a member of a committee of a chamber of commerce that was to investigate the question of a pure water supply and a sewage disposal plant, and to make recommendations to the city council, he would not trust his own judgment unless indeed he were an expert sanitary engineer himself. If he were not such an expert, but had good general powers of scientific judgment, he would use his abilities in the selection of an expert sanitary engineer, and would base his recommendations to the council on the facts of the expert's report and the inferences that might logically be drawn from them.

THE TECHNIQUE OF INSTRUCTION IN THE SCIENCES

CURRENT METHODS. — Three types of method have been commonly used in science instruction during the last ten or fifteen years, known respectively as the recitation, the lecture demonstration, and the laboratory lesson. These are supposed to be closely correlated in a carefully worked out plan; but unfortunately actual inspection of the work carried on in many schools leads to the inference that they are seldom so related.

As witnessed in a large majority of the schools, the recitations represent reproductions seriatim of sections of the subject matter as given in the textbook; and the laboratory lessons are discrete units or tasks to be done. The latter too often have little or no direct logical relation to the former, and in very many cases not even a remote relation. Thus while the current theory of the three methods of instruction is correct, the actual practice is far too often at variance with it.

The Problem as the Center of Unification. — In the light of the principles at which we have arrived, the obvious remedy is

to organize the class work, the demonstrations by the teacher, and the laboratory observations and experiments about definite well-chosen problems, at least so far as that is feasible. If there is no practice in dealing with problematic or forked-road situations, there can be no training in the scientific method, and most of the thinking that may be done will be accidental. It can scarcely be said too often that an effort to recall what some one else has thought out and written in a book or said in a lecture is not thinking, unless indeed the recall occurs in the processes of reflection and reasoning from the known to the unknown. A problematic situation, then, and not a recitation or a lecture demonstration or a laboratory exercise, should be the unit of instruction, excepting in the case of formal review lessons; and even the latter are better when thrown into problematic form. The aim of the student should be to arrive by correct scientific thinking and experimenting at the solution of a significant problem, rather than to recite a lesson or to "do a stunt" in the laboratory for the rather uninteresting purpose of getting a possible mark or escaping such disagreeable consequences as may be expected to follow a failure to satisfy the teacher's demands.

This difference in the attitude of the pupil toward the unit of instruction may seem to some to be of little consequence so long as the pupils actually do the required work; but it is really the condition that determines whether the work of the instructor shall be real scientific teaching or mere perfunctory school keeping. It is the condition that determines whether the pupils are to get training that shall make them at home among scientific ideas and scientific or practical problems, or are merely to be crammed with words and processes that they cannot intelligently connect with things that are meaningful to them in life.

THE CLASS CONFERENCE. — This term is to be preferred to the term "recitation." It represents more nearly the spirit in which the pupils and teacher should meet in the classroom, and the purpose for which they come together. They should meet not in order to take turns in trying to remember and recite

what they have all conned from the same textbook, but rather to confer with one another and with the teacher for the purpose of putting together their individual stocks of significant facts, and criticizing one another's ideas, with reference to a problem in which they are interested and the solution of which they desire to find.

The term "conference" implies that the teacher should not be the only one who asks questions nor the only one who sets forth facts and ideas for the enlightenment of the others. In fact, some of the best class exercises the writer has witnessed have been those in which the pupils were fighting out a disputed question among themselves, one at a time against the pack, while the teacher stood, as it were, on the side lines, and acted as umpire and referee. Too often, the teacher monopolizes the spotlight in the center of the stage, tells too much, and asks four or five inconsequential questions when one incisive query would suffice. One concise, well-directed question or stimulating suggestion from a skillful teacher is often sufficient to start a discussion in which all the required facts and ideas are brought out by the pupils themselves.

The function of the teacher is to supply, by his own example, inspiration and stimulus for attentive, vigorous, consecutive, logical thinking and expression, and to see that all this activity is carried on by the pupils in an orderly and efficient manner. The pupils should be stimulated to ask questions of one another and of the teacher; and when a question is raised, it should, if possible, be answered by the pupils rather than by the teacher. The things to be told by the teacher are those to which the pupils cannot find answers without too much loss of time. Such questions should be answered as concisely, as clearly, and as artistically as possible, and usually in such a way as to stimulate curiosity and provoke further study and inquiry.

Ordinarily, altogether too little importance is attached by teachers to the function of inciting the pupils to raise questions and to answer questions that other pupils raise. Too often the

classroom meeting consists merely of a succession of dialogues between the teacher on one side and various individual pupils on the other side, in which the teacher does most of the talking, and in which the remainder of the class show little or no interest for the reason that they know already very approximately what the substance of each dialogue is going to be. The frequency and logical significance of the questions asked by pupils supply one of the very best measures of the efficiency of a class conference.

THE FUNCTION OF THE LABORATORY. — If the principle of the problem approach be accepted, then a somewhat different function is indicated for the laboratory experiments from that in common use. With the problem as the unit of instruction, the pupil goes to the laboratory to make an experimental test of an hypothesis which he has set up in the process of thinking on a problem. He is in the attitude not of “doing a stunt,” as he would say, nor yet of “fixing a principle in mind,” as some of the syllabus makers have said. Rather is he in the attitude of an inquirer eager to find an answer to a question, and putting the question up to nature herself. He goes there to get information direct from nature, just as the scientist does when he cannot find it in the works of other scientists. Since, however, he is not experienced enough to work independently as the scientist does, the teacher is present to be his helper, inspirer, and guide.

In the laboratory as well as in the classroom the good teacher avoids too much telling, and often answers one question by asking another, or by directing the student to a reference book or map or museum specimen where he can get the required information for himself. He cites a principle to apply oftener than he tells or shows a pupil exactly what to do. He makes every individual “stand on his own feet” in observing, thinking, and experimenting, so far as that individual is capable of doing so. By studying the pupils and the work, he knows when he should help a student and when he should allow him to blunder in order to find out how not to blunder again in a similar way. A com-

mon fault of teachers is to give either too much help or too little. Those who know their subjects well usually give too much help, and those who have imperfect command of the subject are likely to go to the other extreme. Too many teachers know so little about their subjects that they do not find much in them to tell.

The wise teacher will make much of every good idea or piece of work from the pupils, and will be very sparing of fault-finding. He will insist that every pupil complete the work that is assigned to him with as much thoroughness and excellence as he is capable of reaching in a reasonable amount of time. Faulty or careless work should not be punished or drastically criticized, but rather the student should be required to repeat the work and do better. It is not difficult to get pupils to set up an ideal of good work which their own interest compels them to make all reasonable efforts to meet.

Efficient laboratory management demands that apparatus and materials be so methodically cared for and stored that the pupils may have it ready at hand at the beginning of the period, and a minimum of time be consumed in preparing to begin work.

When the materials are of such a nature that this is practicable they should be kept, methodically arranged, in drawers, lockers, or cases from which the students themselves can get them quickly, and to which they can return them quickly when they have finished their work. This is possible even with much of the apparatus used in physics; but in this subject some of the apparatus involves complications in setting up and arranging that would entail too much loss of time if it were not conveniently placed on the table before the beginning of the period.

In the time-consuming work of caring for, repairing, getting out, and replacing apparatus, the teacher should get as much help as is practicable from students. They will usually give it willingly if they are assigned to it in relays so that no one pupil has a burdensome amount to do.

The following criteria will be useful guides in the selection of laboratory exercises :

1. An exercise for the laboratory should provide the means of answering some question or questions that constitute essential steps in the solution of some problem that is significant to the students.

2. It should have some direct and clear connection with what immediately precedes and follows it in the course.

3. It should be one that compels careful observation, discrimination, and reflection, and that affords some opportunity for the development of skill and self-reliance in "putting questions up to nature."

4. There should not be so many things to observe or do that mental confusion will result.

5. It should be so easy of manipulation that the poorest of the qualified students can do the work with fair success and reasonable speed.

6. It must be capable of being done by the students with a respectable degree of accuracy ; and such reasonable accuracy should be insisted on, else the students will have no faith in it or in what it is intended to teach.

7. Wherever practicable the parts of the experiments should be so arranged that the results obtained in them will check one another, thus enabling the students to judge their accuracy by the agreement among the results themselves instead of by comparison with the results given in the books.

Number of Laboratory Exercises per Year. — There ought to be a sufficient number of experiments so that when supplemented by those made at the demonstration table the main outlines of the subject as presented shall rest back on them or on principles that can be shown to rest back on experiments and observations of a similar kind. The minimum amount of laboratory work for each of the sciences according to prevailing ideals and standards is such as will require from thirty to thirty-five double periods a year.

Size of Laboratory Divisions. — There is a very general agreement among leading science teachers that for the best

work there should not be more than twenty pupils in a laboratory division. Exceptionally able teachers successfully handle as many as thirty, but the latter number is considered the upper limit, according to accepted standards of administration, for both recitation and laboratory sections.

Double Periods. — In physics and in chemistry the double laboratory period has come to be considered as an essential feature. Though perhaps not so necessary, it is also very desirable in the other science subjects. Nearly as much actual work can be done in a continuous period of ninety minutes as in three separate periods of forty-five minutes each. In many schools two double periods are given each week, throughout the year, to laboratory work, and three single periods to classroom work. In the opinion of the writer this is a larger proportion of the time than most teachers can profitably use for laboratory work, and the practice results in many cases in neglecting to have principles and applications thoroughly threshed out in class conferences and quizzes. Until the teaching becomes much better than it is now usually found to be, probably better results would be reached by having four single periods and one double laboratory period per week for each science.

Form of Notes. — The notes made by the student on his experiments should contain (*a*) a full and clear but concise statement of the problem that is to be solved or the question that is to be answered by the experiment, (*b*) a brief description of the apparatus and materials used, (*c*) an explanation of the methods of procedure, (*d*) a clearly tabulated statement of numerical data and results, (*e*) all the calculations that were used in obtaining the results, (*f*) the conclusions that were reached, (*g*) a brief discussion of such sources of error as are profitable for the student to consider. The students should be required to express themselves by drawings and graphs wherever such modes of description are obviously of service, but care should be taken that they do not get the idea that

drawings and graphs are ends instead of means. The teacher should use good judgment as to the amount of time that a student should spend in drawing. Much time is often wasted in useless embellishment of notebooks. Students should never be allowed to copy drawings from books. All drawing should be made directly from the objects that are to be represented; and they should show clearly the particular features that are significant in the problem. Ordinarily a sectional diagram showing only the significant features is preferable to a perspective drawing. Set forms for notes containing blanks for the student to fill are often found in laboratory manuals and direction sheets. These are ingenious devices for saving the teachers' and students' time; but they deprive the latter of the training that they ought to get in devising their own forms and arrangements, and in many cases also effectively prevent them from thinking. They are thus of doubtful value if not positively pernicious. The best kind of notes tell a straightforward story in the student's own language about what he wanted to find out, how he went about it, the steps by means of which he reached his answer, and what the answer was.

The best sort of notebook is the loose-leaf type, and the best paper for general purposes is quadrille ruled, in squares one-half centimeter or one fifth inch on a side.¹

Inspection of Notes by the Teacher.—All notes that belong directly to the laboratory work should be made in the laboratory at the time when the experimental work is done; and the sheets on which they are made should not be taken from the laboratory until they have been inspected, checked, and released by the teacher, who should see that they are reasonably full and accurate in statement, reasonably systematic in arrangement, and reasonably legible and presentable in form.²

¹ The most convenient cover known to the writer is the I. P. Number 6 made by the Irving Pitt Co., Kansas City, Mo.

² Cf. comments on specific habits p. 448, *ante*.

The examination of notebooks is grueling work for the teacher, but there is no escape from it if the pupils are to be properly trained. The better the teacher is at inspiring his pupils with ideals of efficiency, the less arduous his work with the notebooks will be. If each exercise is graded before correction by the student, and if correction is required to hold the grade, the pupils will be more careful not to make mistakes.

LECTURE DEMONSTRATIONS. — The reader who has accepted the principles of science teaching that have been set forth in this chapter will agree with the writer that the lecture method finds a very limited place in the instruction of secondary students. Occasionally, however, it may have an important function.

1. When any of the sciences is presented as a series of problems after the manner that has been described, there are gaps to be filled and information to be supplied in order that the subject may be adequately covered as a whole, in its broader outlines, so that unity and coherence of presentation may be preserved. Such information may be effectively presented by informal talks or lectures.

2. Accounts of new discoveries, classical experiments and researches, scientific information of local interest, or of interest in connection with current events may be presented occasionally by lecture and demonstration with preparations, experiments, or lantern slides, as a scientific treat for purposes of inspiration and motivation.

FIELD OBSERVATION. — In Germany and France, the practice of making class excursions for field observation in connection with school studies has long been in vogue. That we have no more of it in this country than the very little we do have is one of the results of our custom of employing as teachers and supervisors persons who are not specially trained and educated for their work. When this form of instruction is uniformly advocated by experts in the various sciences — some going so far as to say that it is indispensable —

and when at the same time it is not generally done, we must conclude either that the teachers fail to know its value or that they do not know how to carry it on. In fact most science teachers freely admit its value, but urge certain difficulties as reasons why they cannot do it. Let us consider a few of these objections, and the answers to them.

1. Excursions are not favored by school authorities above the teacher, or by the parents. *Answer.* By conducting successful voluntary excursions with pupils whose parents do not object, the teachers can demonstrate their value.

2. The school program cannot be so arranged that excursions may be carried on in school hours. *Answer.* Those sciences in which outdoor observation is most essential can often be assigned the last or last two periods in the session; so pupils can be free from other work for the last periods and may use them and the remainder of the afternoon for the excursion. In many cases, outdoor material of great value is to be found near the school, and can be visited in a double school period. A roadside ditch, a row of shade trees, a vacant lot, a blacksmith's or harness shop, all are nature laboratories to him who has eyes to see. If no other way can be found, after-school and Saturday excursions are feasible for a large majority of the pupils; and if a number of these are made during the year, even those pupils who have "music lessons" and "home duties" will probably be able to attend a part of them. If it is objected that attendance cannot be required, the answer is, make them voluntary, and so significant and interesting that the pupils will attend if they possibly can.

3. There is nothing in this locality to be seen. *Answer.* The writer has as yet failed to find a locality where there was not considerable material to see within striking distance of the school.

4. The best localities for study are too far away. *Answer.* In village and rural schools this is seldom true; and if it is, there are always opportunities near the school for field studies

in biology and geography, and there are always a few local industries of interest in connection with physics or chemistry. These, although not the best, may be well worth visiting. In the large cities distances and the difficulties of managing transportation present real and often great obstacles; but the fact that some teachers always overcome the difficulties proves that usually they may be overcome. In such localities doubtless the excursions must almost always be voluntary, and the attendance of all pupils on all the excursions cannot be secured; but teachers who are resourceful enough to make the excursions of real worth to the students secure a large enough attendance to make the practice well worth while.

The following suggestions from the experience of the writer and others, who have handled large bodies of students in such excursions, will prove to be useful.

(1) The maximum number of pupils that can be conveniently handled by one teacher is ordinarily from twenty-five to thirty-five. Exceptionally resourceful teachers can handle a larger number and keep them at work, but inexperienced teachers would better begin with groups of twenty or less.

(2) The teacher should first make himself thoroughly acquainted with the ground to be visited, with the route and means of transportation, and with the special objects to be observed and studied.

(3) The observations should be directed to specific features or phenomena that are factors in some problem or problems that have been set up for solution.

(4) The field lesson should be carefully outlined in a lesson plan that has been checked up by the teacher on the ground, and the plan should be adhered to while the class is in the field.

(5) Mimeographed sheets should be provided beforehand containing questions to be answered from observation and reflection. They should also contain needed directions, hints, or suggestions, for making effective observations, for recording results, and for collecting specimens for individual or school

cabinets. It would be better to have these in the hands of the students a day or two before the excursion is made. These sheets are to perform the same function for the field work that the laboratory manual performs for the laboratory work.

(6) The field work should be explained and the field problems outlined in the classroom on the day before the excursion. The teacher should carefully refrain from answering questions that the pupils can answer for themselves as a result of the field study, but he should make sure that the students understand exactly what they are to look for and to do, exactly what rules of order and discipline they are expected to conform to, and exactly what is the nature of the problems that they are expected to solve in the field. If they are to make collections, they should be told exactly what kinds of samples and specimens they are expected to get and how they are to care for them.

(7) At the next class meeting after the excursion the problems, the observations, and their bearings on the solution of the problems should be thoroughly discussed, and the information and conclusions should be organized so that when the discussion has been concluded, some definite things have been learned, and some tentative or final conclusions of a perfectly definite nature have been reached.

REVIEWS. — A working knowledge of the content of the subject is a necessary part of the ability which the successful study of any science ought to impart; and although it is claimed that both an understanding of the concepts and principles of a science and the ability to recall them when needed are best acquired through solving significant problems, it should be clearly understood that knowledge once acquired is usually forgotten in large part unless occasions for its recall occur at intervals and the part that has been wholly or partly forgotten is relearned. The purpose of the review, then, is to strengthen the association bonds which should be made per-

manent but which as yet are weak. Both pedagogical experience and the few experimental studies of memorizing and forgetting that have been made indicate that it is more economical to review or relearn frequently at first and then at greater and greater intervals, than it is to try by many repetitions to fix the memory bonds permanently during the first learning period. So far as our present knowledge of learning and forgetting goes, it confirms the very general opinion of successful teachers that frequent reviews are necessary. The time-honored custom of conducting carefully planned formal reviews at the end of each week, each month, and each term, and at the end of the year, should be adhered to. The intervals need not be exactly those mentioned, but may preferably be adjusted to the minor and major logical divisions of the subject matter. Efficiency requires that we spend no time unnecessarily on that which is most easily and permanently remembered, or on formally reviewing that which is bound to be recalled anyway at sufficiently frequent intervals in consequence of being needed as bases for conclusions to be reached in later lessons. It requires us, rather, to select carefully that which most needs to be relearned; and to drill on that at intervals of increasing length until it is correctly recalled when required.

Hence, the review lesson has two obvious functions: (1) to find out what things have been wholly or partly forgotten and need to be relearned; and (2) to provide situations that will cause the students to relearn them. Topical recitations, written recitations, and review matches in which sides are chosen and total scores compared, are all effective for organizing subject matter, or for fixing it in mind.¹

The Topical Recitation. — Pupils write on the blackboard the headings and subheadings of a topical outline. Other pupils in turn briefly and rapidly explain the more important facts and relations that come under the topics. Each is

¹ Cf. Strayer, G. D., *A Brief Course in the Teaching Process*. Macmillan, New York, 1912, Chap. IX.

quizzed by the teacher whenever the latter suspects that his specific knowledge of the content represented by the sub-headings is inadequate. The teacher also stimulates the other pupils to quiz him when they desire fuller information as to any of the subtopics. Occasionally one recites on a topic without the aid of a blackboard outline. These outlines should be made by the pupils, never dictated by the teacher. The habit of making such outlines should be formed in connection with summing up and organizing the subject matter in the class conferences.

Written Reviews. — These are very useful not only as reviews but also as furnishing practice to the pupils in reducing their acquired information to writing on demand. Students who have examinations to pass should have much practice of this kind. One reason why so many students “go to pieces” on examinations is that they have not had sufficient practice in taking written tests to acquire familiarity with that kind of situation and skill in that kind of performance. Questions and numerical problems for such reviews should be numerous and short, rather than long and complicated. They should be so framed as to call for a maximum of content with a minimum of writing, and should be split up into units representing facts, meanings, relations, etc., having values that supposedly are approximately equal. Thus each item may receive a single and definite score. This makes grading easy, and also more just. It also makes it possible to find out which ideas are the hardest for the pupils or are least perfectly known by them. An idea, for example, which is reproduced correctly by 50 per cent of the pupils is of median difficulty for the class; and one which is reproduced correctly by only 25 per cent of the pupils is more difficult than the former, but less difficult than one that is correctly reproduced by only 20 per cent. One which is reproduced correctly by all of them is so easy (*i.e.* has been so well learned) that it did not need to be reviewed.

THE SCIENCES AND THE CURRICULUM

COLLEGE ENTRANCE REQUIREMENTS. — The high schools grew out of a popular demand for a kind of secondary education that would be better adapted to the needs of all classes than was that given by the academies and college preparatory schools; “but the high schools gravitated toward the colleges, as the academies had done before them.”¹ The teachers and principals gave their best energies toward the preparation for college of the small percentage of their pupils whose aim was toward a higher education. Previous to the last decade of the nineteenth century every college set its entrance requirements in accordance with its own notions, without reference to those of any other college; and the high schools tried to meet them all, so that their graduates might pass the entrance examinations of the various colleges that they wished to attend. The lack of uniformity in the preparation required by different students in the same school, and the conflict between the needs of those who were preparing for college and those who were aiming directly toward employment in the various occupations, brought about an intolerable situation for the high schools. Greater uniformity in the administrative machinery that had to do with admission to the colleges, and a simplification of the means of adjustment became an urgent necessity. The movement toward uniformity began with the Report of the Committee of Ten of the National Education Association in 1893, gathered headway with the reports of the Committee on College Entrance Requirements of the same association in 1896 and 1899, and culminated in the organization of the College Entrance Examination Board in 1900.² The reports and syllabi published by these committees, and the bulletins of the College Entrance

¹ Brown, Elmer E., *The Making of Our Middle Schools*. Longmans, Green, & Co., New York, 1902, p. 373.

² Cf. Mann, C. R., *The Teaching of Physics*. The Macmillan Co., 1912, Chap. I.

Board of the various colleges, and of certain state departments of education, all of which have been based mainly on those reports, have in large measure shaped the curricula of the high schools and determined the character of the teaching.

As far as science is concerned the results have been both good and bad. Among the good results are the establishment of the principles (1) that high school teachers should have adequate collegiate training for their work, (2) that laboratory work, field excursions, and some reference book work should be carried on in connection with each of the sciences, (3) that schools should be adequately equipped with laboratories, apparatus, and libraries for such work, (4) that double laboratory periods for the laboratory exercises should be provided in the time schedules, (5) that laboratory notes should be systematically entered in suitable books by the students, and (6) that the pupils should be taught not merely to memorize, but to think. Among the bad results have been (1) the tendency to cast all the instruction in one mold in the attempts to meet the specifications of syllabi and examinations, (2) the overemphasis on the assimilation of subject matter and the consequent undervaluation of the scientific method of study, by means of which the subject matter of science is best acquired, and most of all (3) the discouragement of initiative on the part of school teachers and administrators because of the burdensome amounts of subject matter that were called for by these authoritative syllabi. The tendency was rather toward cramming the pupils with facts and laws than toward putting them in situations that would necessitate thinking. The path for reform lies obviously in the direction of changes in the syllabi in consequence of which they shall contain a minimum of prescription and a maximum of suggestion, especially as to the use of the scientific method or problem approach in teaching, as to the organization of the subject matter about suitable problems for observational and experimental study, and as to the rich variety of practical applications of scientific

principles and laws that may be found in all sorts of localities. The introduction of such flexible and suggestive syllabi must be accompanied also by better training of science teachers themselves. Science teachers should not know less of their special subjects than they do, but they should be given a wider range of scientific knowledge, better training in the principles of the scientific method, and some special training in modern psychology as applied in the principles of teaching.

Along with more flexible syllabi and better training of teachers for intelligent experimentation on both subject matters and methods of teaching must come an attitude and a procedure on the part of both college professors and school administrators which shall make science teachers feel free to apply the method of intentional variation, testing, and selection to both subject matter and methods. In other words teachers must apply the scientific method to the study of their teaching problems, if science study is to do for their pupils what scientists and psychologists believe that it can do and ought to do. We must learn to teach science more nearly in a scientific — that is, in a psychological — way; and this we can learn only by observation, experimentation, and measurement. This means that a selected few of the best trained, most enterprising, and ablest secondary science teachers must become research students in experimental pedagogy, and that the results of their experiments must be published, critically reviewed, and put into the hands of all science teachers as suggestive material for their further guidance.

THE SCIENCE SUBJECTS. — The subjects that are now more or less generally taught in high schools are physical geography, botany, zoölogy, physiology, physics, and chemistry. Astronomy and geology, which were widely in vogue up to about 1880, are now seldom taught in high schools. Meteorology, which was strongly recommended by the Committee of Ten as an advanced elective, is almost never taught as a separate science, but the most significant portion of its content is

pretty generally taught as a part of physical geography, or in connection with "general science" courses, which are being introduced in some schools as an experiment. Agriculture is also coming rapidly to be a part of the curriculum in many rural, village, and agricultural high schools; and even in some of the technical high schools in large cities.

The Committee on College Entrance Requirements recommended for high schools the following courses in the natural and physical sciences, to be given in the order named:

First year, physical geography; second year, biology or botany or zoölogy, or botany and zoölogy; third year, physics; fourth year, chemistry.

It seems to be very generally agreed, on both theoretical and practical grounds, that the general order recommended by the Committee is the best. In fact the general order here given is usually followed; although physical geography is frequently given as a half-year course, either followed by physiology or botany or agriculture or preceded by a half-year course in "elementary" or "general" science. The recommendation "that the time allowance for each of these courses be at least four periods a week throughout the year"¹ has also been pretty generally followed, although the definition of the unit has since received a modification giving it greater flexibility. A unit in science is now defined as the equivalent of one hundred and twenty sixty-minute hours of classroom work, two hours of laboratory or field work counting as one hour of class work.²

GEOGRAPHY

GEOGRAPHIC CONTROLS. — The activities of man in carrying out his life purposes are controlled by the distribution of heat and moisture. These in turn are controlled by the

¹ *Proc. N. E. A.*, 1899, p. 651.

² *Document 48*, December 1, 1910, College Entrance Board. Substation 84, New York.

movements of the atmosphere, and these again by the form and movements of the earth and its relations to the sun. Streams, lakes, and oceans, mountains, plains, plateaus, valleys, and shore lines, all combine in various ways to affect his activities both directly and through their effects on the distribution of plants and animals, of soils and other mineral resources. All these interdependent forms and agencies constitute the environment to which man must adjust himself, or which, when he can with advantage, he adjusts to himself. To effect this adjustment to his environment he must understand it, — he must comprehend it; and herein lies the central motive for the study of geography. The process of adjustment, which is life itself, gives rise to multitudes of problems to be solved. Problems of vital utility and problems of absorbing intellectual interest grow directly out of the pupil's daily life, and reach out to the distant parts of the earth and off through millions of miles of space to the sun.

BEGIN WITH LOCAL PROBLEMS. — To the teacher who has the point of view that has been set forth in this chapter it will be obvious that the study of physical geography should begin with intimate home problems. Perhaps no better one to begin with could be found than that suggested by the question "How do we get our drinking and wash water?" In the country this would lead at once to wells and cisterns and the conditions that maintain them, and thence to the sources and movements of ground water. This would lead to problems of farm and village drainage, the effect on crops, and to other related facts and conditions affecting or controlling farm and village life. Directly connected with drainage problems are the problems of soils. What kinds of soils are found in this locality? What crops grow best in each kind? Why do these soils differ? From what were they made? (Rocks and rock-forming minerals.) These questions lead to the study of the processes of weathering and stream erosion as related to rainfall and to the production and transportation of rock

waste. The study of neighboring streams, which the solution of these problems necessitates, raises other questions as to where the stream begins (springs and lakes) and where it goes (river system, river basin, life history of rivers, and the kinds of control rivers exert on population at their various stages of development). The study of the drainage basin to which the locality belongs also leads, either immediately or later, as the teacher may decide, to the study of the larger physiographic region of which it is a part, and to the life relations that exist between this part and the whole. The study of the local rainfall in relation to water supply for man, beast, and vegetation leads back to the conditions that produce the precipitation and distribution of atmospheric moisture; and this in turn to atmospheric movements, weather, climate, and the relation of climate to topographic features. Thus each problem suggests others which are more or less closely related to it, or grow directly out of it. As these problems are solved, the information accumulated should be organized and built up into small systems,¹ which in turn are incorporated into larger outlines as the knowledge of the pupils grows. In the city the question of water supply leads to a study of the city water plant, this to the source of supply, and this in turn to the study of streams and their work. The problem of city sewage disposal leads also to the streams and suggests a question of grave import to every city. Is our water supply polluted by sewage from our own city or elsewhere?

Again, what roads and railways bring in our food and raw materials and carry out our manufactured products? Why were these routes chosen? (Valleys, ancient lake beaches, mountain barriers and passes, road-making materials, etc.) There should be no difficulty in starting such problems in approaching any new topic whatever. If the teacher is not inhibited by traditions of "logical order," they will bristle up in such abundance that one will be ready for every lesson.

¹ Cf. p. 452, *ante*.

For the child, the personal relation is the natural, psychological starting point of interest in every one of them;¹ and next to this comes the social relation.² The question, "Where does our coal come from?" leads not only, say to the dissected Allegheny plateau and its origin and history as a physiographic feature, but also to the questions, What kinds of people are the miners who get this coal out of the ground for us? How do they live? How do they work? Where do they come from? (Poland, Hungary, Sicily, etc.) Why did they emigrate? So the same problem, according to the turn the teacher gives it, leads, through personal and social relations, to the study of a distant part of our own country or even to the countries beyond the seas.

TEXTBOOKS. — There are half a dozen excellent and (at least to an adult) attractive textbooks on physical geography which differ but little one from another either in the amount or the choice of subject matter that they present. It matters little which one the teacher uses. What really matters is the way in which he uses it. The wrong way is to assign a lesson to be studied and recited from the book. The right way is to start a problem and send the pupils to the book for information which, combined with their own observations and reflections, and the assistance given by the teacher, will help them to solve it. Textbook study, field and laboratory study, class conferences, all then become means instead of ends. For the pupil the end is no longer to make a perfunctory recitation from artificial academic motives, but to find out something that he wants to know, because he can see that it has meaning and value in connection with the realization of his own life purposes and activities and with the purposes and activities of people whom he finds are in some way related to him. The textbook then finds its proper place as a mine

¹ Cf. Dewey, John., *Interest and Effort*. Houghton, Mifflin Co., 1913, pp. 23 ff.

² *Ibid.*, pp. 84 ff.

of information and a guide for organization and review. "Pupils, from the start, must be impressed with the fact that geography is a study of the earth and not of the book."¹

In connection with the use of a textbook it is important for the teachers to recognize three facts: (1) Every one of the textbooks has more matter in it than any high school pupil can assimilate in a year; hence selection is absolutely necessary. (2) The teacher should make the selection, using only the materials that can be made significant and comprehensible to the pupils of his own locality. There is more danger in attempting to cover too much ground than there is of covering too little. (3) There will always be differences in the significance of topics due to differences between localities; and therefore for any locality the treatment of the text on some topics may not be full enough to suit the case. Here the teacher must supplement the text from other sources, such as special monographs and government reports. On this principle, the pupils of Colorado would study mountains in more detail and pay less attention to the ocean and shore lines than would pupils on the sea coast. The latter would study mountains less in detail because mountains and mountainous conditions are farther removed from their actual experience and are therefore less significant to them. A careful study of the local features is the only means of rendering the unseen features intelligible.

REPORTS OF NATIONAL COMMITTEES, BOOKS, AND MAGAZINE ARTICLES. — The young teachers of physical and commercial geography will find themselves highly favored with suggestive material for their guidance in choice of subject matter and special methods of instruction, for leading geographers have written generously for their guidance. Every teacher of this subject should study carefully the Report of the Conferences on Geography in the Report of the

¹ Sutherland, William J., *The Teaching of Geography*. Scott, Foresman & Co., Chicago, 1909, p. 43.

Committee of Ten¹ and the Report of the Committee on College Entrance Requirements of the National Education Association,² the Report of the Committee on Geography of the Department of Science Instruction of the N. E. A.,³ the Report of the Committee on Geography for Secondary Schools of the Association of American Geographers.⁴ In the last of these reports, there will be noted a general progressive tendency away from the specialized "physiography" that had become common in 1909 and toward a humanized "general geography" which emphasizes human adjustments to geographic controls.⁵ With this movement the writer is in heartiest sympathy. Three magazines, to which every secondary geography teacher should have frequent access, are replete with suggestive material, on both subject matter and method, *School Science and Mathematics*,⁶ *The Journal of Geography*,⁷ and *The National Geographic Magazine*,⁸ and no geography teacher can afford not to own and study *The International Geography*.⁹ *The Teaching of Geography*, by William J. Sutherland, although intended primarily for grade teachers, is the most helpful guide for secondary teachers known to the writer; and is entirely free from the taint of "faculty" and "formal discipline" psychology against which the teacher must be on his guard in most of the pedagogical literature on the subject. It contains extensive and carefully selected bibliographies and suggestions for laboratory equipment.¹⁰

¹ American Book Co., 1894.

² *Proc. N. E. A.*, 1899, pp. 632 ff. and 780 ff.

³ *Proc. N. E. A.*, 1909, p. 820.

⁴ *Journal of Geography*, Madison, Wis., Vol. IX, No. 3, p. 57; No. 9, p. 244. Reports 1, 3, and 4 are abstracted in Whitbeck and Martin, *The High School Course in Geography*, *Bulletin No. 382, University of Wisconsin*, an exceedingly valuable pamphlet.

⁵ Whitbeck, R. H., and Martin, L., *op. cit.*

⁶ Published by Smith and Turton, No. 2059 E. 72d Place, Chicago.

⁷ Published at Madison, Wis.

⁸ Published by the Nat. Geog. Soc., Washington, D.C.

⁹ Edited by Mill, R. H., D. Appleton & Co., New York, \$3.50.

¹⁰ Published by Scott, Foresman & Co., Chicago, 1909.

PHYSIOGRAPHIC PROCESSES. — The processes which combine to produce the different land forms are of three general kinds.

1. Large areas of the earth's crust slowly sink down in some parts of the earth and other areas are arched or folded upward.

2. The crust in some places becomes fractured, and lava is thrust up from the heated interior, either locally as in volcanoes and fissure eruptions, or over large areas as in the case of the Columbia River lava plateau.

3. The elevated lands are weathered by the action of the atmospheric gases and moisture combined with changes of temperature; and the water that falls on them as rain or snow moves downward as streams or glaciers, carrying away the wasted rock and grinding down the land. The condition of the land and the forms into which it is molded or carved are the resultant of these three kinds of processes, just as each of these processes is itself the resultant of physical and chemical forces and conditions that are operating in various combinations everywhere and at all times.

The Geographic Cycle. — Because these physiographic processes follow in sequences of cause and effect, there results in the case of a plain, plateau, or mountain system a sequence of changes whereby valleys are carved into the uplifted lands and are gradually deepened and widened until ultimately the uplands between are worn away to a very even and gently sloping plain interrupted only by occasional portions of the more resistant uplands. Thus the streams themselves and the lands through which they flow go through sequences of changes which can be predicted when the conditions are known, and which are somewhat analogous to the larger changes that go on in the life history of a plant or animal. This notion of a geographic cycle including the life history periods of youth, maturity, and old age, when applied to river systems, lakes, plains, mountains, and shore lines, is very useful as a means of organizing geographical

facts and phenomena into condensed and meaningful concepts that are easy to remember because of their obvious causal relations. These concepts in turn are useful in connection with the understanding of the controls that these physiographic features, when combined with natural and social forces, exert on the life and activities of the people who live near them.

Physiographic Controls. — Thus we have the controls of temperature and moisture, of rocks and soils, of the atmosphere and its movements, of the mutual interactions of living things (organic controls), of topographic features and barriers, and of the forces and motives that direct human conduct (human and social controls). So also we have the responses of individuals and social groups to these controls. Some of the most interesting responses are those wherein organized groups of men, such as corporations and state or national governments, through their agents and engineers build roads and railroads, irrigate deserts, dig a Panama Canal, dredge harbors, dam and bridge streams, create forest reserves, build fires in orchards on frosty nights, and do many other things that control nature herself for human needs. All such actions and reactions constitute the processes of geographic adjustment whereby men get on with nature and with one another. The study of all these controls and adjustments, their causes and consequences, involves the consideration of causes and effects. Not merely what is this like and where is it located, but how came it to be, and what will be the consequences, are the questions for which the inquiring mind seeks answers; and the boys and girls have a right to these answers so far as they want them, can understand them, and can get them mostly through their own efforts.

PRINCIPLES OF SELECTION AND ORDER. — Summing up, then, we have the controlling principles of method: (1) begin with problems and begin at home; (2) connect the far with the near and the unknown with the known by human

relationships; (3) use the textbook as a help in the accumulation and organization of facts; (4) use the causal notion as a link for organization in the ordering of concepts; (5) trace physiographic features back to physiographic processes and these back to physical causes; (6) use the cycle concept and the concept of adjustment as unifying principles.

FIELD WORK, LABORATORY WORK, AND EQUIPMENT. — The textbook has been referred to as a mine of information, but its information can become meaningful only when it connects up with knowledge gained by observation at first hand in the field and laboratory. The laboratory work is immensely important but is less so than the field observation. It cannot be presumed that the casual observation of out-of-door facts by the pupils will be sufficient to make the laboratory work and the textbook study meaningful.

As much has been said about field and laboratory methods as our space will allow.¹ One hint for each must suffice. Study weathering of boulders, or of monuments in a cemetery or of stones in old houses, if no exposed rocks can be found. Study erosion of exposed earth thrown from a building excavation or in a railroad embankment, if no stream is within reach. Gullies showing in miniature nearly all the stages of stream work and valley development can be found even in cities. Make maps and sketches, describe processes, state causes for variations in form, direction, slope, and width of gullies, and for speed of water in different parts. Find miniature alluvial fans and deltas. Compare with text descriptions, maps, and pictures of similar features on a larger scale in other places. In the laboratory, study minerals and rocks, wall maps, large-scale topographic maps. Read and interpret maps and pictures; infer life conditions; and verify inferences from gazetteers and reports. On topographic maps follow roads and railroads and infer why they are located as they are. Study weather maps. Describe weather and make predictions.

¹ *Ante*, pp. 462-470.

Follow the storms across the country in a succession of weather maps and compare observation with newspaper accounts. These are mere suggestions by way of illustration. The teacher will find information and hints as to field and laboratory problems, and as to equipment of laboratories in the appendices of Davis' and Tarr's Physical Geographies, in Sutherland,¹ in Whitbeck and Martin's bulletin,² in any of the laboratory manuals that are put out to accompany the well-known texts, and in the references in the bibliography. It should always be borne in mind that a laboratory exercise, if it is to be of real educative value, is not to be a disciplinary task, but a step in the solution of a problem.³

ORDER OF TOPICS. — The general order of topics favored by the writer is as follows: 1. Underground water. 2. Streams and lakes. 3. Rocks and soils. 4. The lands. 5. The atmosphere. 6. The earth as a whole. 7. Review of physical geography on a regional basis. 8. Review on the basis of distribution of vegetation and animal life. 9. Review on the basis of human relationships, economic, industrial, and social. 10. Review on the basis of locational geography.⁴ Let the pupils list the significant places mentioned in current numbers of the daily newspaper and the *Review of Reviews*, *Literary Digest*, or *Current Opinion*. Locate them accurately on the wall maps, and drill by locating them on outline seat maps such as are used in history study. This kind of work should not be confined to the final review, but should be carried on also in connection with the other phases of the subject. All places, streams, plains, mountains, and the like, whose locations are important should be located when studied as types or examples. For example, if the "fall line" that marks the boundary between the Piedmont plateau and the Atlantic coastal plain is being studied, the principal manu-

¹ *Op. cit.*, pp. 193 ff., 202 ff., 211 ff., and Chaps. XIX, XX, and XXI.

² *Op. cit.*, pp. 36-41.

³ Cf. p. 462, *ante*.

⁴ Cf. Whitbeck and Martin, *op. cit.*, pp. 27 ff.

facturing cities that mark the line should be located in the manner described.

The order recommended is not necessarily the best for all schools. Other orders may be as good; but the writer is convinced that it is a pedagogical mistake to begin with mathematical geography. No better way to kill interest could be found.

BIOLOGY

BIOLOGICAL PROBLEMS. — Plants and animals may be either useful or harmful to man and his activities. They are sources of manifold utilities. Their life activities present features of dramatic interest, for they are often compelled to engage in fierce competition in the hard struggle for existence, — to fight for their lives in the midst of a hostile environment. Their activities bear many obvious analogies to those of the human body. Like the human body a plant or an animal is a living, working machine, whose parts are adapted, both in form and structure, to perform certain functions in the service of the whole.

They thus present a multitude of problems that are of immediate and intense human interest, if approached from the side that is suggested by such human relations as have been mentioned. Biological study therefore affords interesting and absorbing opportunities for acquiring information that is useful to everybody in many fields of thought and work. Not only that, but it enables the teacher who has broad biological points of view to lead his pupils in directing their thinking in the biological field, and also their interpretations of human activities, from these illuminating and suggestive viewpoints.

POINTS OF VIEW FROM BIOLOGICAL STUDY. — One gets a certain point of view when he has come through first-hand observation to know that every living plant or animal is made up of cells which are themselves living individ-

uals like the amœba or the unicellular plant. He has gained a broader outlook when he realizes that the necessity of adaptation to more complex and difficult situations is accompanied by division of labor, by differentiation of functions, so that special groups of cells are modified in form, structure, and distribution, with the result that each group performs some one of the specialized activities that are necessary to the survival of the organism in its more complex environment. He can see farther still if he gets the notion that there is in plant and in animal life a series of great groups beginning with unicellular forms and continually increasing in complexity by such divisions of labor and specializations of organs. If, through observations and experiments which he makes himself, he learns of the responses that plants make to the stimuli of light, gravity, moisture, soil, pressure, or atmosphere, to other plants, and to insects; if he notes the general process of adjustment of which these responses are the elementary factors; if he gets even elementary notions of development, of variation, of elimination and survival, of mutations and inheritance as factors in biological evolution, he gains an outlook on life as a whole that will make more meaningful everything that he afterwards learns about living things.¹

Further if the student learns the meaning of biological observations, experiments, descriptions, and interpretations, and perceives the relations of form and structure to functions, he will get the experimental point of view and perhaps habits of attacking his problems in a methodical way. He may perhaps come to prefer first-hand knowledge to book knowledge in some limited field at least. He may not be able to make discoveries, nor to settle the mooted questions of biology; but he will be able to find out for himself some things that are new to him, and to get some clear notions as to how biological questions

¹ In this connection caution is necessary. The reader should study carefully the discussion by Professor Bigelow as to how far the teaching of evolution should be carried in secondary schools. Lloyd, F. E., and Bigelow, M. A., *The Teaching of Biology in Secondary Schools*. Longmans, New York, 1904, pp. 286 ff.

should be attacked. Particularly, he can be taught the meaning and use of a control experiment,¹ and how to tell a good experiment from the bad one from which no logical conclusions can be drawn.

PRINCIPLES TO BE OBSERVED IN A BIOLOGICAL COURSE. — There are certain biological and pedagogical principles that should be prominent in the mind of the teacher in shaping and conducting a course in either botany or zoölogy or human biology.

1. The development of the type concept. When we speak of the frog or the common buttercup (*Ranunculus bulbosus*), ordinarily, we do not mean any particular individual, nor do we mean all the animals or all the plants of the species named. Rather we mean any one that is typical of the whole species or group to which it belongs. A hundred individuals of a given species collected at random will be alike in certain characteristics, but will vary among themselves in many minor ways. If then we wanted a specimen that would stand as a fair representative or type of the species, we should pick one that was near the average. This is what is meant by a typical individual of a species. When a biologist describes a species, he describes what he estimates is a typical individual of that species. So whenever a species is thought of, these individual differences or variations should be thought of also. Now the individuals of any species that are near the type resemble each other more closely than they resemble those of any other species. In the same way, species which resemble each other more closely than they resemble other species are grouped in larger divisions called genera. On a like basis genera are grouped into families, families into orders, and so on. For convenience in study an individual of a species may be taken as a type form of a genus or of a family. The student, after studying the type in sufficient detail, can then learn in what

¹That is, two experiments are run side by side, in which all the conditions excepting the one under investigation are as nearly as possible exactly alike.

important respects the representatives of the related genera or families differ from this type, and thus get a relatively large amount of information in condensed form. It is obvious that this type concept is of immense importance to the student; and the teacher should be at some pains to have it grow up naturally in connection with whatever samples of biological material the pupils are dealing with. They should get the notion not only of a typical plant or animal, but of a typical seed, leaf, or other organ of either plant or animal.¹ It is only by forming type notions through the careful study and comparison of a relatively small number of types that anything like a general survey of living forms can be made. Biological teaching therefore must perforce be made through comparative study of type forms.

2. The comparative principle. This brings us to the next principle of biological study, the development through habit formation of a comparative attitude on the part of the pupil. Having made himself acquainted with a grasshopper, for example, the pupil is led to compare its near relatives, the cricket and katydid, with it, so that he knows qualities of structure, physiology, habits, and life history which they have in common, and also the important ways in which the other two differ from the first as a type. Again, making a study of the crayfish with regard to structure, physiological processes, habits, life history, and so on, he compares the lobster and crab with it after the same plan that he pursued with the grasshopper and its near relatives. He is then in a position to compare the crayfish as a type of all crustaceans with the grasshopper as a type of all insects, and learn in what ways the crustaceans differ from the insects, and why they are grouped together as arthropods. He will easily accomplish more and will remember characteristics better, as he goes along, if he uses the type and comparative notions from the first. In other words, the crayfish will mean more to him

¹ Cf. Lloyd and Bigelow, *op. cit.*, pp. 126 ff.

while he is studying it if he has a clear notion of the grasshopper at the time, and is working with the comparative attitude. He will then be looking for the resemblances and differences; and hence every characteristic of structure, function, behavior, and life history will mean more to him than it would if he had no comparisons in mind.

3. Classification. The next principle follows quite naturally from the second. By noting resemblances and differences in the process of comparing types, the pupil arrives in a perfectly natural way at the principle of classification and gets a first-hand appreciation of its economy and value as a means of organizing and rendering intelligible a mass of facts which otherwise handled would be chaotic.

4. Form and structure as related to function. In form and structure, the animal as a whole, and its organs as working parts of it, are adapted to the activities in which they engage, the functions that they are called upon to perform. No child who has tried to capture a grasshopper in the field will have the slightest difficulty in grasping the notion that one of the grasshopper's necessities is to escape his enemies, that his ability to hop quickly, or to fly, enables him to do so, and that his legs and wings are admirably adapted to provide him with this ability. Here then is one of the countless starting points for a lesson problem. What is the mechanism of the grasshopper's leg that enables him to star in the standing broad jump? Why can he jump so much farther in proportion to his length than the best boy on the track team can jump? When this problem of the relation of structure to function has been solved, others present themselves in profusion. What is the structure of the wings and body, and the arrangement of the muscles that enables them all to cooperate so efficiently in balancing and flying? How are the mouth parts adapted to eating? How is the food digested? How does the insect breathe? Has he a nervous system, and if so what is it like? How is it adapted to the functions that it has

to perform? These questions indicate clearly that the right method of approach is not to study morphology or physiology or ecology separately, but to study them together by working out problems on a type. They indicate also that in biology as in all the other sciences the joint activity of the teacher and pupils in field work, in laboratory work, and in class conferences is unified in the problems.

5. Adjustment, division of labor, and coöperation. Life involves a continuous process of adjustment to environment. If the environment of the organism is simple, the adjustment processes are simple, and few specialized organs are found to exist. If the environment is complex or difficult, necessitating many adjustments, more parts or organs are advantageous, and the organism is found to be complex. There is division of labor and specialization of groups of cells adapted to perform the various kinds of adjustments both among the working internal parts of the living machine and in the organs by which it responds to stimuli from without. Thus we have the principle of adjustment correlating with the principles of coöperation and division of labor on the physiological and ecological side, and with the principle of adaptation and differentiation of parts on the morphological side. Physiology and ecology then present the dynamic phase, and morphology (including anatomy, histology, and classification) represents the static phase in the study of the same life process, — adjustment. Out of this relation comes the fifth principle in biological pedagogy: study structure and function together, as related to adjustment, in one type, and compare with analogous adjustments and the structures and functions related thereto in other types.

6. Continuity of life, — life history and race history. Each plant or animal type has a life history. From the union of two reproductive cells and the fission of the new cell thus formed until the new individual dies, it goes through a cycle of changes from a simple to an increasingly complex condition.

Some of the individuals before they die reproduce their kind and hand on their progeny to continue the life of the race of organisms as a whole. In the history of the races of plants and animals some species as species have become extinct and others have survived. Just as there is a life history for the individual of a species, so for the race there is a succession of changes from simple and undifferentiated forms to complex and highly specialized forms. These changes constitute a race history which can be more or less clearly traced in the successive relationships that the later groups bear to the earlier.

7. The theory of evolution. Thus life, which is limited in the individual, is continuous in the race, and in the struggle for existence those qualities tend in the long run to be handed on which have survival value — that is, which help to preserve the lives of individuals so that they can live to reproduce their kind. So survival is connected with advantageous adjustment to environment; and a process of natural selection goes on. By variation and selection the race of organisms becomes adjusted to varying conditions; and the newer and more complex forms result.

The young student cannot follow all the evidence in favor of organic evolution, or go very far into the theories concerning its various factors, or debate the questions which biological specialists have not been able to settle among themselves; but his attention can be called to the most obvious facts and relations that point in the direction of progress by variation and selection; and he can thus get a broad notion of the evolutionary process. The important rule for the teacher is to refrain from dogmatizing or quoting authorities in place of citing facts, either for or against any statement of theory, and to lead the students to maintain an open-minded attitude and get their own point of view.¹

¹ Read Professor Lloyd's statement, Lloyd and Bigelow, *op. cit.*, pp. 136 ff., and compare it with Professor Bigelow's, p. 286, previously referred to.

GENERAL METHOD IN BIOLOGICAL STUDY. — The preceding principles furnish the basis for a general method in teaching biology. Start with problems that involve the study of a type plant or animal. Study it as a whole, with reference to its general form and structure as related to the work that it has to do. Note its differentiation into parts and the work to which each essential part is adapted. Make comparisons showing the clearest analogies in the case of other types, carrying the comparisons far enough to give a general idea of the plant or animal as a working machine or organism with coöperating parts.

Continue with a similar study of the parts in a somewhat more intensive way (but with plants, still paying more attention to the comparison of similar organs through a somewhat extensive range of forms than to the intensive study of the type as a type).

After a good general idea of the working organs as organs has been gained, concentrate on a more intensive study of the type, with reference to its physiology and internal structure, and its ecology, behavior, life history, and economic and human relations. Proceed with other types in turn in a similar way, examining them with reference to their morphology as related to physiology and ecology, but with the exception of two or three types make the work progressively more extensive and less intensive — that is, put increasing stress on comparison of types, and on economic and human relations and gradually diminishing stress on detailed study of anatomy and physiology. Lead up to the classification and evolution concepts. In studying the physiological processes compare these processes not only in the field of plants or animals, but correlate in plants and animals and in human physiology. Make the largest possible use of local and living material and of local human and economic relations that is consistent with the broader aims of the course.

SPECIAL METHODS. — The special methods must always

be worked out by the individual teachers each for his own school, and no attempt will be made to outline them here. The best way for a beginner to acquire methods is to master the principles and notions of general method, study and compare the presentations of the various textbooks and laboratory guides, study and compare critically the various syllabi with reference to local conditions, and read the pedagogical literature that is available on the subject.¹ Lloyd and Bigelow, whose book should be owned and studied by every biology teacher, discuss laboratory methods and equipment as well as general and special method in botany, zoölogy, and human physiology with sufficient detail to meet the needs even of inexperienced teachers.

CORRELATION OF BOTANY, ZOÖLOGY, AND PHYSIOLOGY. — For a course of one year in biological study there are three plans from which to choose: 1. A half year of botany, followed by a half year of zoölogy, closing with a brief survey of human physiology;² 2. A year of botany only; 3. A year of zoölogy only. From the standpoint of a well-balanced curriculum for the purposes of general education the writer agrees with a number of leading biologists in favoring the first plan. In case the second is adopted he believes that sufficient botanical details should be excluded from the course to give time for frequent comparisons of animals with

¹ Especially Lloyd and Bigelow, *op. cit.*; the current and many of the back numbers of *School Science and Mathematics*. The Report of the Botanical Society of America on Botany in Secondary Schools, in *School Review*, November, 1908 (Vol. 16, p. 594). Ganong, W. F., *The Teaching Botanist*, Macmillan, 1910. *The Report of the American Society of Zoölogists on Zoölogy for Secondary Schools*, College Entrance Board, Substation 84, New York, Document 48; and the Definitions of Units in Botany and Zoölogy in the *Reports of the Commission on Accredited Schools of the North Central Association of Colleges and Secondary Schools*, which may be obtained from the Secretary, Principal J. E. Armstrong, Englewood High School, Chicago, price twenty-five cents.

² For excellent outlines of such a course, worked out in a single textbook, see Bailey, L. H., and Coleman, W. M., *First Course in Biology*, Macmillan, New York, 1908; Hunter, G. W., *Elements of Biology*, American Book Co., 1907; and Bigelow, M. A., and A. N., *Introduction to Biology*, Macmillan, New York, 1913.

plants to make their common physiological resemblances and differences clear; and in case the third plan is adopted he believes that a similar comparative use of botanical material should be made; and that in any of the three plans the broader correlations of plant, animal, and human physiology should be made at every point where they will be clear and illuminating.

PHYSICS

COMMON-SENSE NOTIONS, AND PHYSICAL PRINCIPLES. — In his *Science of Mechanics*¹ Mach has shown that the early discoveries of mechanical laws and principles grew out of thinking that was aroused by problematic situations in which there seemed to be some incongruity between observed physical facts and the intuitive or common-sense notions about them which crystallize, so to speak, out of the manifold experiences of the individual and the race in dealing with the materials and tools of the industries. Physical principles, such as that of the lever and that of flotation in mechanics, that of the distribution of heat by convection currents, that of the equality of the angles of incidence and reflection for light, or Ohm's law of flow for electric currents, are merely concise and convenient ways of describing events that persistently recur under certain circumstances. As Mach points out,² such a "law" or "principle" is an economical device of thought, which enables us to keep in mind by means of a single statement or formula a multitude of single occurrences that are alike in certain essential qualities or relations, although widely separated perhaps in both time and space. The principle states the relation that these single

¹ Open Court Publishing Co., Chicago, 1907, *loc. cit.*, pp. 1-7, also 77-85. (The word "intuitive" is preferable to the word "instinctive" used in the English translation of Mach's book. Instinctive is probably intended only in a figurative sense; but it is psychologically misleading in the connection used. An instinctive reaction is one that is *unlearned*; an intuitive one is *learned, but untaught*. This evidently is what Mach meant.)

² *Op. cit.*, pp. 481 ff.

occurrences have in common. Those who have discovered such generalizations, as Mach shows,¹ have often used their intuitive notions, derived from familiar experiences, as guides in their thinking. So it is with us all, with children no less than with adults. New experiences which do not conflict with our intuitive knowledge, or common sense as we are wont to call it, are taken as matters of course, and do not arouse any feeling of doubt or incongruity. Understanding of principles grows by checking up new particular cases that are found to come under them, with the aid of these intuitions as guides. By this trying-out process both the principles and the guiding intuitions are clarified and made more precise and meaningful. One gets ultimately "a comprehensive, compact, consistent, and facile conception of the facts."²

Intuitions and the Facts of Everyday Life as Starting Points. — It is very important that the teacher, at the outset, recognize this function of intuitions and also that he keep in mind the close interplay of science and the industries, and so start his teaching of physical principles with problematic concrete situations in which the pupil senses a difficulty, or an incongruity with his intuitive experiential knowledge. Such a situation — one that involves a strange or novel element among the familiar occurrences of daily observation, and therefore piques the pupil's curiosity and arouses his interest — is the only kind of situation in which he will think. There is a vast difference, from the psychological and educational standpoint, between thinking and merely trying to recall dogmatic statements from the textbook. In the former case the pupil is acquiring meanings, learning to reflect, and learning to reason; while in the latter he is forming short-circuit memory bonds that cannot, ex-

¹ *Op. cit.*, pp. 26 ff. Every teacher of physics should read the entire chapter, especially Section V. The chapter, for the most part, is not easy reading, but it affords an outlook that is well worth the trouble required to gain it.

² Mach, *op. cit.*, p. 5.

cepting by mere chance, function in real situations outside the schoolroom.

Such short-circuit memory connections furnish one explanation for the condition so often described by teachers when they complain that pupils "know the principle, but cannot apply it." In such cases it is obvious that they do not know the principle. The only association bond existing in their brain cells is the bond between the situation of being asked the question, "State (say) Pascal's law of fluid pressure" on the stimulus side, and recalling the sequence of words, "The pressure in a fluid in a closed vessel is transmitted . . . etc.," on the response side. The necessary association bonds have not been formed between the idea of undiminished transmission of fluid pressure, on the one hand, and a lot of concrete cases, on the other hand.

Such bonds can be formed in most cases only by a considerable number of concrete mental and motor experiences with fluids whose behavior under transmitted pressure has been intelligently and thoughtfully observed and measured in some way. Pupils cannot be railroaded into a knowledge of physical principles. Real knowledge of a law or principle, — that is, facility or skill in using it, can be gained only by practice in dealing with problematic situations in which it is involved. Thus, if the pupil has gained such experience by measuring, with a pressure gauge, the pressure at several water taps which are located on the same floor of a building and which come from pipes that have various diameters and that turn and twist in various directions, and if he has made similar measurements on one or two other floors, he will have little difficulty in grasping the idea and connecting it in the class conferences with similar cases elsewhere. By such a process a clear and meaningful concept of fluid pressure can be built up in his mind.

Words, definitions, statements of laws and principles, algebraic formulæ, are mere symbols. They are indispensable in

science for economy in thought; but they are almost absolutely useless to any individual unless he himself has a clear and precise notion or concept of the things or relations for which each symbol stands. A thorough and intelligent appreciation of this fundamental psychological principle is absolutely essential for real success in teaching anything; but it is more likely to be fatally overlooked by teachers of physics and chemistry than by teachers of some other subjects, because of the highly symbolic, condensed, and technical language in which these sciences are set forth in the treatises. The very excellence of logical organization to which these fascinating sciences have attained is on the one hand a source of the gravest danger to all attempts to teach them to young people, and on the other hand, if rightly used, a means of the highest value in forming habits of logical thinking.

Some Intuitive Notions Described. — What are the common-sense notions or intuitive judgments that constitute so important a part of the mental raw materials with which the physics teacher must begin? We know no logical order in which to name them; and, as Mach shows,¹ it is useless to try to ascribe either priority or higher authority to one of them in preference to another; for they are all as it were *sui generis*, each being derived from a fund of experiences which is as worthy of confidence as any other. Hence the order in which they are here set down is not significant. Neither is it claimed that the enumeration is complete. It is intended only to be suggestive.

1. The continuity of nature, the notion that things that have always been so will always be so under similar conditions.² In the teaching, the examination of conditions is the process on which a great part of any given problem turns.

¹ *Loc. cit.*, pp. 80 ff.

² Cf. Mann, C. R., and Twiss, G. R., *Physics*. Scott, Foresman & Co., Chicago, 1910, p. 17.

2. The causal notion,¹ the intuitive habit of connecting in thought two things that always go together, either in sequence or simultaneously, and of looking for a similar relation which intelligibly connects a strange thing or event with things or events that are familiarly known. This intuitive tendency finds an outlet in the ubiquitous question of the young child, "Mother, what makes it do that?" The teacher who can revive and foster this naïve desire of the children to know the why of things — a desire which is universally crushed by our conventional social and educational procedure in dealing with it—may know by this token that his methods in so far forth are right methods.

3. The notion of balancing, and of a connection of balancing with symmetry about the point or line of support. Here is a guiding intuition for all problems about center of gravity, equilibrium, stability, levers, and so on. Every child who has played with a seesaw, played store with toy scales, balanced his body, "trimmed" a boat, carried packages in two hands, and the like, knows something about these problems and will be keen to know more, if his interest is not stifled by making him begin with reciting a book lesson about gravity or the law of the lever.

4. The notion of force, derived from the sensations of muscular exertion in pushing and pulling things with the hands, striking balls with bats, chopping with hatchets, driving nails and pegs with hammers and stones, supporting weights, and the like. This notion again is usually clear enough in the pupil's mind if instead of being asked to define force he is asked how it can be measured.

5. The notion of work, derived from lifting weights, pushing and dragging things against resistance, and so on. This notion, again, is made clear not by defining it metaphysically ;

¹ For a complete but simple discussion of the logical and scientific uses of this notion, see Jones, A. L., *Logic, Inductive and Deductive*. Henry Holt & Co., New York, 1909, pp. 79-109. Cf. also Mach, *op. cit.*, pp. 483-485 and 579.

but by showing in many cases that work can be measured by the numerical product, pounds force multiplied by distance.¹

6. The notion of inertia, derived from running and dodging, from starting and stopping massive bodies, riding in vehicles.

7. The correlative idea of mass, expressed in the common saying that "large bodies move slowly." This idea is usually confused with that of weight; and some care and a good deal of time and regulated experience in making the proper distinctions are needed to clear it up. Much of the difficulty here will be avoided if the teacher always makes the distinction correctly in his own speech and does not insist on having the pupils understand and make it before they have had sufficient experience with the phenomena in which mass and weight can be differentiated.

8. The impossibility of a perpetual motion against a resistance, derived from the continuous exertion required to keep bodies moving and their tendency to stop when the urging force is relaxed, and from observation of swinging bodies which never rise to higher levels than those from which they started. This intuition is commonly expressed in the saying that "water never rises higher than its source," or that, "you cannot get more work out of a machine than you put into it." The interest of many boys in suggested conflicts with this intuitive notion is striking. They will often think hard and argue keenly with one another in an endeavor to find the fallacies that lurk in such perpetual-motion propositions.

The Questions of Tyndall's Boys.—In a lecture on

¹ Cf. Mann, C. R., *The Teaching of Physics*. The Macmillan Co., New York, 1912, pp. 225-233. No teacher of physics, experienced or otherwise, can afford not to read this book, and reflect on the vital questions respecting physics teaching that are discussed therein. It has the almost unique advantage among books on science teaching of being written from the standpoint of modern psychology and is free from the taint of the discredited faculty and formal discipline psychology.

Physics as a means of Education¹ Tyndall gives a few questions selected at random from among those asked by his boys, students at an agricultural school in Hampshire. These questions were asked and discussed by the boys and their teachers at the meetings of a scientific club that they had formed. There were all sorts of questions, most of them asking for the causes of things. They exhibit the spirit of wonder that is so important for the science teacher to foster; and a few of them are just such problems as best serve for starting points from which to arrive at important physical principles.

What are the duties of the Astronomer Royal? What is frost? Why are thunder and lightning more frequent in summer than in winter? What occasions falling stars? What is the cause of the sensation of "pins and needles"? What is the cause of waterspouts? What is the cause of hiccup? If a towel be wetted with water, why does the wet portion become darker than before? What is meant by Lancashire witches? Does the dew rise or fall? What is the principle of the hydraulic press? Is there more oxygen in the air in summer than in winter? What are those rings that we see around the gas and the sun? What is thunder? How is it (sic) that a black hat can be moved by forming around it a magnetic circle, while a white hat remains stationary?² What is the cause of perspiration? Is it true that men were

¹ In *Culture Demanded by Modern Life*, edited by E. L. Youmans, Appleton, New York, 1875, pp. 59-85. Science teachers who have not read this eloquent and inspiring presentation of the culture value of science, by probably the most gifted teacher of physics that ever lived, should do so. The same volume contains a lecture by Liebig on "The Development of Scientific Ideas," which shows the close natural connection between science and the industries.

² This might have been some conjuring trick or a mere superstitious tradition; but it would seem unlikely that such a teacher as Tyndall would neglect the opportunity to incite the boys to find out in this case the relative merits of credulity and knowledge by putting this question to the test of experiment. Cf. Hall, G. Stanley, *Adolescence*, Vol. II, p. 157, wherein the author calls attention to the neglected field of scientific toys and conjuring tricks as sources of problems possessing strong motivating power for study of the principles of physics.

once monkeys? What is the difference between the soul and the mind? ¹ Is it contrary to the rules of vegetarianism to eat eggs?

These are but a few of the many that were asked; but they suggest countless nodes of interest from which problems may be made to bud out at the command of a sympathetic and resourceful teacher. Tyndall then selects the questions of the wetted towel, and the deposition of dew, and in his truly wonderful way shows how they can be explained by means of a few simple physical principles. The following quotation will suggest the way in which such principles were led up to and enforced through some problems that enabled his boys to apply their knowledge of arithmetic and geometry, not to "recite" for the teacher, but to find out something that they were keen to know. The class he describes was supposed to be studying geometry; but it is evident that no water-tight bulkheads existed between mathematics and science for such a teacher as Tyndall. The selection also exemplifies that infectious enthusiasm that is indispensable to successful science teaching.

"It was often my custom to give the boys their choice of pursuing their propositions in the book, or of trying their strength on others not to be found there. Never in a single instance have I known the book to be chosen. . . .

"And then again, the pleasure we all experienced was enhanced when we applied our mathematical knowledge to the solution of physical problems. Many objects of hourly contact had thus a new interest and significance imparted to them. The swing, the seesaw, the tension of the giant-stride ropes, the fall and rebound of the football, the advantage of a small boy over a large one when turning short, particularly in slippery weather; all became subjects of investigation. Supposing a lady to stand before a looking-glass, of the same

¹ This is a poser, but is instructive as showing the range of questions over which some children ponder.

height as herself, it was required to know how much of the glass was really useful to the lady? and we learned, with great pleasure, the economic fact that she might dispense with the lower half and see her whole figure notwithstanding. We also felt deep interest in ascertaining from the hum of a bee the number of times the little insect flaps its wings in a second.”¹

ECONOMY OF TIME AND EFFORT. — It is often objected that the problem approach requires too much time, — that there is so much ground to be covered that conditions will not admit of it. But of what use is covering the ground by a cramming process which leaves the pupils with confused and detached ideas, and a distaste for the subject? On the other hand, a reorganization of the subject matter about the larger and more general principles, and the exclusion of topics that are either too difficult for pupils to comprehend, or are lacking in significance to them because of not making intelligible connections with their experiences, makes it possible to save much time. Everybody admits that the current textbooks are overloaded; then why try to have the pupils swallow them whole?² Let us see what can be done by better organization. Instead of having the pupils learn as discrete ideas a separate law for each of the simple machines, including three different classes of levers, all these machines can be shown to come under two general statements. The principle of moments and the work principle, *i.e.* neglecting friction, the work got out of the machine equals the work put into it; and by a very elementary and obvious algebraic substitution any case coming under the former principle can be brought under the latter. Out of the work principle directly we get the efficiency equation also. So one single principle, or two at most, covers all these cases or any others similar to them.

¹ Youmans, *op. cit.*, pp. 80 ff.

² Each author during the last twenty years has had to include all the topics covered by his predecessors and add a few more in order that his publishers' agents might meet the "talking points" of their competitors. For the manifest absurdity of the result, see Mann, *op. cit.*, p. 208.

To this principle add that of the parallelogram of motions, Newton's third law, and clarified statements of the intuitive notions of gravity, inertia, mass, and uniform speed, and you have practically all the principles under mechanics of solids that it is worth while trying to teach pupils of high school age. All the other details will be more easily remembered because associated with these few principles, well understood, instead of being scattered in many discrete groups.¹

In a similar way, each one of the less comprehensive principles of heat, electricity, sound, and light may be approached through simple, interesting problems, some qualitative and more of them quantitative, all of them starting with knowledge that the pupils already possess and proceeding by consecutive steps of experimentation and reasoning toward the goal. Like those of mechanics, these in turn can be shown to be comprehended by a few larger and more inclusive principles which make up the theoretical framework of the whole subject.

FUNDAMENTAL CONCEPTS. — Thus we have the few fundamental concepts of physics, time and space, mass and inertia, electricity and ether, all related to one another and made apparent through the transformations and transferences of energy that take place in connection with phenomena that are described by them. So also we have the great comprehensive principles of action and reaction, of the conservation of energy, of the degradation of energy, and of relativity which serve to sum up and connect all the facts and phenomena which the beginner in physical science can successfully examine and fairly master. The molecular and electron theories may perhaps be given at the end of the course, but are not needed for the effective organization of the most important and significant facts. The earlier introduction of these theories will certainly serve only to confuse the pupils and draw them away

¹ To see how this reorganization has been effected in a plan that is working successfully in many schools, examine the first three chapters of Mann and Twiss, *op. cit.*, pp. 17-67.

from the safe and firm ground of facts that they can grasp through first-hand observation and experimentation into what, at least for them, must remain a treacherous atmosphere of speculation.¹

SYLLABI. — To those teachers who are in such circumstances that they must conform to the content of the syllabi of the College Entrance Examination Board or those of state authorities, it may be said that the plan of organization and teaching here outlined can be followed under these syllabi if careful attention is given to relative emphasis on the various items that the syllabi call for. None of their makers ever intended that the syllabi should be followed slavishly as to order of topics or that the same emphasis should be placed on every item. Even if this really had to be done, better results could be obtained by devoting the bulk of the year to real teaching after the manner here described, and devoting three or four weeks at the end of the course to a "cramming" review for the examinations.

LABORATORY WORK. — The method for physics outlined in this chapter will not necessitate discarding immediately the laboratory equipment that the school has on hand. A number of the experiments usually made in the laboratory are lacking in significance and are not worth the time that is spent on them; but the greater part of them may be made valuable if they are presented in a better way. For example, take one of those on specific gravity. Approached in the customary way, the purpose of the experiment is usually stated as follows, "To find the specific gravity of a solid that sinks in water." Stated thus, it has no significance. There is no motive. Why should the student care to find the specific gravity of "a solid" that he is not going to do anything with? Suppose, on the other hand, we raise the question as to how

¹ For suggestions as to a detailed elaboration of such a course as has been indicated, see the chapters on the various divisions of the subject in the Mann and Twiss *Physics* and read Mann's *Teaching of Physics*, Part III.

much work will be required to lift a large block of stone to its position in a neighboring building under construction. The answer, of course, can be obtained by multiplying the weight by the height to which it is to be lifted; but how are we to find the weight? A little questioning will usually elicit from the pupils the suggestion that the dimensions can easily be measured and the volume calculated. Then if we knew the weight of a unit of volume of the stone, we could multiply this by the total volume and get the weight of the block, also the weight for unit volume of the stone can be found by determining the specific gravity of a sample of it. Again, suppose that instead of assigning an experiment "to determine the specific gravity of a liquid" the teacher proposes that the pupils find out whether the milk that they are receiving at their homes has been watered. There will then be a real motive for finding the specific gravity of the milk and for making a hydrometer which they can use for that purpose at home.¹ Other changes in attitude of the same sort can easily be made by every teacher for himself. Thus pupils need no longer make an experiment "to find the electrical resistance of a wire," but can find out "whether a tungsten lamp if substituted for a carbon lamp will save more than its increased cost," and so on. Under this sort of teaching, the laboratory experiment, instead of being abstract, formal, and meaningless to the pupils, becomes a necessary step in the solution of a live human problem that the pupils have some real, sane reason for desiring to solve.

THE PROGRESSIVE PROGRAM. — (1) The content of the modern physics course is not objectionable in itself, but is too bulky and needs to be cut down.

(2) We must drop out the highly abstract and theoretical, the incidental and insignificant. Whatever is entirely foreign to the pupils' present purposes, present knowledge, and daily

¹ For such an experiment see Twiss, G. R., *Laboratory Exercises in Physics*. Scott, Foresman & Co., Chicago, 1906, p. 88.

experiences, and cannot be connected up with it through significant problems in whose answers they can be vitally interested, should be eliminated.

(3) There must be a change in emphasis that will result in paying most attention to the "big dynamic things"¹ in physics, and to those facts and minor principles which have a human bearing, which are exemplified in the pupil's own locality, and which are therefore significant because they raise questions in whose answers the pupils can see some use.

(4) Minor and special principles and definitions must be justified before the pupils are required to learn them. This can be done only by putting the pupils in situations where the need for these definitions or principles is apparent in connection with the work they are doing. In other words, definitions, principles, and generalizations are justified by leading up to them inductively through concrete problems that arise out of the pupil's previous knowledge and their spirit of wonder or intellectual curiosity.

(5) There should be a constant grouping of similar phenomena under the definitions or laws or principles which describe them; and a continuous process of organization, showing how each group of phenomena takes its place with other groups under a broader principle or generalization, thus building up the content of the science in the pupils' minds as a unified and classified whole. This means a reorganization of the courses usually given, and an entire change in the mode of approach so as to arrive at the abstract and general by the way of the concrete and particular, instead of *vice versa*.

(6) The teacher should neglect no opportunity that will enable him to aid the pupils in forming association bonds between the physical ideas acquired in the schoolroom and the various kinds of problems of everyday life which those principles assist in solving. In other words let them learn to apply their physical knowledge by practice in applying it.

¹ Cf. Mann, *op. cit.*, Chap. X.

If these principles are applied in the teaching, lack of interest in the subject will be rare; and the outcome is almost certain to be satisfactory.

CHEMISTRY

THE PSYCHOLOGICAL BASIS. — Chemistry is *par excellence* the experimental science, inasmuch as little chemical knowledge of consequence can be learned without making experiments. Observation here plays fully as important a rôle as in the other sciences; but very little can be observed of the chemistry of substances without first doing something with them. Thus, chemical experiments appeal directly to a fundamental instinct. "To do something and have something happen as the consequence is, other things being equal, instinctively satisfying, whatever be done and whatever be the consequent happening."¹ This is fortunate for the psychological teaching of chemistry, because perception of its facts and acquisition of its concepts are not favored so highly as in the other sciences by familiar experiences and common-sense intuitions, in terms of which the facts and relations that are presented in the teaching can be interpreted; and it is therefore not so easy to make obvious connections between chemical lore and everyday-life situations as it is to make such connections in presenting the other sciences. But although the chemistry teacher is thus at a disadvantage, he has strong allies in the original tendencies to manipulate² and experiment. In the case of chemistry, then, if we are to start our teaching with a problem growing out of the child's experience, we must let him get the necessary experience by making chemical experiments himself, and in the beginning depend for motivation largely on his original tendencies toward manipulation and toward "doing things to have something happen," plus

¹ Thorndike, E. L., *The Original Nature of Man*. Teachers College, Columbia University, New York, 1913, p. 142.

² *Ibid.*, pp. 135-138.

whatever liking for purposeful experimentation he may have been fortunate enough to have acquired through previous scientific training in school or out.

If this be true, then two conclusions follow, which might indeed have been inferred from common-sense considerations, apart from psychology, namely: (1) it is of little avail to attempt to teach chemistry without a large amount of individual laboratory experimentation, and (2) the very first lesson, and every succeeding lesson in which a new topic is taken up, should be an experimental problem in which the pupil himself is the experimenter, guided and assisted, of course, by the teacher.

HOW TO BEGIN. — Many teachers and many textbooks make the traditional mistake of beginning with general observations about chemistry, its value, and its relations to the other sciences, with definitions of physical and chemical changes, of elements, compounds, and mixtures, and even of atoms and molecules. This is not only productive of gross waste of time, but tends also to form the habit in the pupils of depending for their facts on books and authority instead of forming in them the habit of making their own judgments on the basis of what the facts themselves have to reveal to them through their senses. To create such an attitude at the start is fatal to the scientific spirit which it is the mission of science teaching to engender. Furthermore, it is of course impossible for pupils to form any conception of the meaning of a generalization or definition unless they have become acquainted through first-hand experience with a considerable number of the specific facts of which it is a general or condensed statement. The wise teacher then will seek at once for some problems that can be solved only by experiments simple enough for the pupils themselves to carry out, and that at the same time lead straight toward some of the important facts and principles of chemistry. A number of these can be found which lead directly to the preparation

of oxygen, and which grow naturally out of common experience.

For example, why is iron always nickel plated, or covered with paint? If rusting is not at once suggested, let the teacher then show some specimens of badly rusted iron; and if the students think they have solved the problem when they have said that the nickel plating or painting is to keep the iron from rusting, let him ask them why. If they answer that the covering keeps the air away from the iron, let him ask them why they think the air has anything to do with it. If they are sharp enough to answer this question logically, let him ask them how the air causes the iron to rust. Here their experiential knowledge will stop unless, perchance, some one suggests that iron does not rust in a dry attic but does rust in a moist cellar. Obviously, the next question is, "If the rusting of the iron is connected with the presence of moist air, does the iron take something from the air to make the new substance, rust; or does the air take something from the iron?"¹ The answer can be obtained by inverting in a dish of water a test tube into which some moist powdered iron has been introduced so as to stick to its walls near its closed end. The iron soon rusts, and water rises and occupies about a fifth of the volume of the tube, when the action stops, leaving some of the iron unruled. The obvious inference is that the iron takes away one fifth of the air, and that when it has done so, that portion of the air which was capable of taking part in the rusting process was used up, so no more iron was rusted. If the tube be removed and a lighted taper plunged into it, the flame is extinguished, showing that the part of the air used up was that part which supports combustion. Powdered iron in

¹ For the detailed procedure in solving this problem so as to get to the bottom of it, see Smith, A., and Hall, E. H., *The Teaching of Chemistry and Physics*. Longmans, New York, 1904, pp. 107 ff. The Chemistry section of this book should be read and reread by every teacher of chemistry. It is the soundest, most thorough, and most helpful discussion of the pedagogy of chemistry that is known to the writer.

a watch glass counterpoised on a balance and left in a moist atmosphere gradually rusts and is seen to increase in weight. Thus it is proved conclusively that something from the moist air is added to the iron to make it rust. These experiments may be followed by heating weighed mercury, tin, and lead in porcelain crucibles, noting the respective changes in properties and the increases in weight. The early historical knowledge of these changes can then be recounted, oxygen prepared from mercuric oxide, like that obtained by heating, and the experiments of Priestley and Lavoisier explained. The pupils will then be keen to prepare oxygen in larger amounts from potassium chlorate and "do things with it to find out what will happen." In this way their memory bonds between oxygen and its properties will be formed and may be firmly established by later reviews and drills. Also they are more likely to catch the scientific spirit than if they began with definitions and formal experiments "to illustrate and make clear" the difference between physical and chemical changes, and the difference between compounds and mixtures.

The teacher who knows how to work experiments for all they are worth will bring these differences out clearly in connection with the experiments described; and if so brought out, they will be better remembered because learned in connection with problems that can be seen to lead to some significant goal. The advantage lies in the mental attitude of the pupil. The formal and didactic approach tends to make him lean on the crutch of authority, while the problem approach tends toward the open-minded scientific attitude and the desire to know and prove truth for its social utility. The experiments suggested are by no means the only mode of problem approach. Oxygen can be led up to in connection with building fires, the burning of candles,¹ lamps, and Bunsen burners, putting

¹ For suggestions see Faraday, Michael, *The Chemical History of a Candle*. Harpers, New York, 1899. This classic example of lecture presentation of chemical facts and principles to youngsters should be read by every teacher of chemistry.

out fires, respiration, the useful properties and constitution of water, and so on.¹

HOW TO USE THE TEXTBOOK. — Many of the modern textbooks of chemistry, though excellent in other characteristics, do not present the facts in an order that suggests the problem approach. This, however, need not prevent the teacher from giving the pupils the benefits of this method. If the teacher remembers the true function of the textbook as a reference book for facts that cannot be easily obtained by direct experiment either at the demonstration table or by the students themselves, and as a guide in the logical organization and review of facts, principles, and theories, he will use his ingenuity in devising suitable problematic situations through which the different topics can be approached. He will not send the pupils to the book beforehand to find out from the printed page what they should find out with their own eyes, noses, and hands. It is wrong to suppose that in the early stages of scientific study time can be saved by learning facts from books. The pupil does not learn the facts thus. He merely learns words and formulæ which for him can have no content because he lacks the experiential knowledge which alone can enable him to apperceive them.² Later on, after he has accumulated a considerable amount of facts through first-hand experience, has perceived their relations, and has formulated these relations, largely for himself, in the form of laws, principles, and generalizations, he is in a position to use chemical books, articles, and reports with the right attitude; and it is then safe to assign book lessons and ref-

¹ For an approach through an experiment to detect cotton in alleged woolen cloth and leading inductively to certain fundamental distinctions of chemical science, see Smith, Alexander, *Elementary Chemistry*, The Century Co., New York, 1914. The entire method of this intensely modern text ought to be given serious study by teachers.

² Cf. Thorndike, E. L., *The Principles of Teaching*, A. G. Seiler, New York, 1906, pp. 42 ff., and Bagley, W. C., *The Educative Process*, Macmillan, New York, 1907, Chap. V, or James, William, *Talks to Teachers of Psychology*, Holt, New York, 1905, Chap. XIV.

erences to such articles and reports. The teacher, however, can never be too careful in hammering in the notion that every one of the chemical facts that is to be learned from a book is simply a statement of results attained by experiment, observation, and measurement or by reasoning founded thereon.

THE CONTENT OF CHEMISTRY. — Like other scientific subject matter, chemical information consists of facts, laws, hypotheses, and theories and their history; and this body of information has been built up and is being extended by the use of the scientific method. Like the other sciences, chemistry has its own peculiar special methods of procedure which are found to be most expedient in the solution of chemical problems. The facts, of course, are first and fundamental. The laws are merely convenient condensed statements under which like facts and like relations between groups of facts are summed up. The hypotheses and theories are merely convenient ways of describing the facts by conceiving them to be like facts with which we are more intimately acquainted.

Since the laws and theories, if they are thoroughly understood, are very helpful for economizing time in memorizing facts and recalling them when needed, it is very important that the student should know the laws and theories that he is capable of comprehending. But he cannot comprehend the laws and theories, and therefore they cannot be helpful to him, unless he first knows the facts or at least a considerable portion of the facts which the laws summarize or the theories explain. Hence the following rules are very important for the teacher of chemistry:

1. Begin with the facts of observation and experiment and stick to such facts throughout the course.
2. Withhold laws until a sufficient number of the facts and relations that are specific cases of the law have been studied and have become familiar. The law can then be appreciated as a device for the economy of thought.

3. When a law has once been presented, have the pupils connect the statement of the law with every new specific case that comes under it, until they habitually do this for themselves.

4. Withhold theories until they are needed to furnish explanations of observed facts. Do not be in such a hurry to teach theories that the facts are subordinated to them. Laws and theories are man-made devices for describing facts. Facts are not to be degraded into illustrations or examples of the operation of laws and theories. Laws and theories do not "operate." They merely say what in general goes on under certain conditions. If at any time the facts shall be found with certainty not to agree with them, then they must be altered to fit the facts as the facts are.

5. If the students fail to understand a law or theory when it is presented, do not insist on their memorizing it so they can repeat it glibly at once. Give them time and more experience with concrete cases, and after a while they will have learned it. They will be all too ready to substitute the memory of a few words for knowledge of facts unless they are made to form the contrary habit. Generalizations are of supreme importance if the facts that they resume are comprehended and can be recalled and used with their aid; otherwise they are useless.

6. Laws and theories therefore should be introduced gradually as the course proceeds, and the more difficult conceptions should come near the end of the course. This principle is recognized in greater or less degree in most elementary texts; and in many of them the highly theoretical matters — such as the making of formulæ: Avogadro's law, the atomic and molecular theories, valency, ionization — are placed in chapters by themselves so that they can be deferred or omitted altogether, according to the judgment of the teacher. In all cases when they are taught these theoretical matters should be led up to through quantitative demonstrations or descriptions, and copious illustration. Whenever chemical theories serve to muddle and disgust the pupils instead of interesting them

and clarifying their ideas, such a result is proof either that the conceptions are beyond the pupils' abilities or that the teaching is inefficient, or both.¹

7. The laws of chemistry should always be expressed in such language as clearly to imply that they are statements of the results of experiments. Thus for the law of definite proportions, "Every sample of any compound substance is always found to contain the same constituent elements in the same proportions by weight."²

Chemical Laws. — The law of definite proportions, the law of the conservation of mass, and Gay-Lussac's law of volumes are among the most important generalizations of chemistry; and fortunately they are not difficult for high school pupils to comprehend if they are carefully approached. The law of simple multiple proportions can usually be taught successfully, but is not especially important to beginners, and may be omitted with little loss. The law of combining weights, which is a more general statement of the two preceding, is important, but probably too difficult and doubtless should not be attempted.

The use of the physical laws of Boyle and Charles and the law of vapor pressure in correcting measured gas volumes usually proves to be difficult for high school students; but the difficulties can be overcome if the teacher carefully explains and illustrates the behavior of gases which they describe, and does so in direct connection with the actual measurement of the gases at the demonstration table. Often, the difficulties arise because the teacher assumes that the pupils know these laws from their previous study of physics. He perhaps overlooks the fact that in the lapse of nearly a year they will almost certainly have forgotten how to apply them. Other

¹ For a full discussion of this question of chemical theory, read Smith and Hall, *op. cit.*, pp. 69-84, and also Schoch, E. P., *Chemistry in High Schools*, Bull. Univ. of Texas, No. 210, Official Series 64, Austin, Tex., December, 1911, pp. 44-60 *passim*. See also the theoretical chapters of Professor Smith's *Elementary Chemistry* and compare those in other texts.

² Smith, A., *op. cit.* p. 21.

difficulties arise from the elevation of these problems of the correction of measured gas volumes into ends instead of means.

Type Reactions. — It is wise to develop strongly the type notion in chemistry and to show at every opportunity that the reactions encountered are types of many others that are like them. Thus instead of having the pupils learn that oxygen can be obtained from mercuric oxide or potassium chlorate by heating, a fine opportunity for the appreciation of science as economy of thought will be missed unless the teacher shows in connection with the experiment that many other compounds of oxygen, such as BaO_2 , PbO_2 , KNO_2 , MnO_2 , break down in a similar manner when raised to high temperatures, and give up all or part of their oxygen. Thus the behavior of HgO or KClO_3 is typical of the other reactions shown. So when hydrogen is obtained by displacing it from hydrochloric acid by zinc, the reactions of other non-oxidizing acids with zinc and other metals should be shown and explained. This reaction then no longer remains a "method of making hydrogen," but in addition becomes a type of the general behavior of non-oxidizing acids with metals that stand above hydrogen in the list of the elements, when the latter are arranged in the order of their electrochemical activities.

If the teacher forms the habit of emphasizing such groups of similar reactions, pointing out their resemblances to one chosen as a type, and concentrating the students' attention on the general resemblances and specific differences among the reactions of the group, he will find not only that he saves time in the end, but that he secures unlooked-for reviews, stimulates interest, and forms in the student the valuable mental habit of using the type notion to organize and relate his chemical concepts. Practice in thus forming generalizations that are true only within certain limits, and carefully confining them in thought to those limits, constitutes a

very valuable part of the mental discipline afforded by science.¹

Careful attention to the types of reaction would result in a much more pedagogical arrangement of the subject matter than is found in many texts; for the simplest types of reactions could be grouped at the beginning of the course and the more complicated types near the end. Such an arrangement would bring in the reactions of combination and decomposition, reversible reactions (which belong to both the preceding classes), hydration, displacement, and double decomposition, approximately in the order named, and leave many of those involving oxidation, reduction, and change of valence (such as the reactions of nitric acid with the metals) until later.²

Practical Applications. — Though it is not feasible in most cases to make the approach to new topics through household and industrial applications of chemistry, this may perhaps be done occasionally when the reactions involved are sufficiently simple. The mistake is often made of straining a point by beginning with some industrial fact or process with which the students are totally unfamiliar and which at the same time is so complicated that it presupposes for its comprehension knowledge of chemical principles that have not yet been studied. Nothing could be worse pedagogically than this. Again the mistake is often made in high school courses in so-called "applied" or "industrial" chemistry of requiring the pupils to memorize complicated details of processes in which no easily perceived applications of chemical principles are involved and out of which no clear chemical concepts can be evolved.

Although the industrial applications often involve complicated chemistry and unfamiliar substances, there are nevertheless in every community some applications that

¹ Cf. p. 488, *ante*, the type notion in biology.

² Cf. Schoch, *op. cit.*, p. 47.

can be examined and are simple enough to be understood; so the teacher should make himself acquainted with these and connect them with the chemical facts and principles that are applied in them, at the time when these are being studied. There are many fairly simple chemical substances and reactions that are very common and very important to know about, such as the prevention of industrial waste through the utilization of by-products in manufacturing processes, the chemistry of flames, raising of bread and biscuits, respiration, digestion, sanitation, fermentation, drying of paint, setting of mortar and cement, making of glass, soap, coal gas, domestic ammonia, soda water, explosives and plastics, inks, dyes, and varnishes, the nature and sources of alcohol and vinegar, of oils, petroleum and gasoline, of carbohydrates, fats, proteins, and cellulose in foods, of soils and fertilizers and insecticides. How much or how little of these is to be brought into the course must depend on the knowledge and judgment of the teacher, the ease or difficulty of bringing the illustrations into the classroom or taking the class to them, the amount of knowledge and interest that the pupils bring to them, the closeness of their relation to the main features of the course, and many other considerations concerning which only the teacher himself can decide. Some of these things can be made the subjects of excursions, others of special home experiments and reports by those especially interested in them. Others still the teacher may merely explain and illustrate, leaving the seeds to fall on good ground when they may, without digging them up to see whether they have sprouted. It is certain that if the teacher is full of such information, and is enthusiastic about it, some of the pupils will be infected with this enthusiasm all the time, and all of them some of the time; and chemistry in that school will be rated as a popular and practical subject.

To save time for such work, the less common elements and compounds may be omitted, and the most of the more

highly theoretical parts of the subject can be carefully explained and illustrated by the teacher and informally discussed by the class, but passed over without requiring that it shall be mastered. If the writer's observations and those of most of the college chemistry teachers of his acquaintance are reliable, he is justified in the opinion that only in rare instances are these theoretical parts mastered anyway. There is no sense in expecting that every student will know every part of the course as well as every other part. Such an ideal grows out of a very poor conception of thoroughness. It is important that the pupils should know well and intimately a few of the chemical facts and laws that they are likely to meet with now or later in their active life or their leisure reading, that they should catch the spirit and method and something of the logic of chemistry, that they should know how to plan and make an experiment, and that they should know where to find chemical books and how to get needed information out of them. It is not important that they should become walking encyclopedias of chemical information.

THE TEACHER

PERSONALITY. — To be successful, the teacher must be an optimist, must be an enthusiast for the science that he or she is teaching, must be willing to work hard, must be genuinely interested in his pupils and their success. He must himself possess the open-minded scientific spirit, and must be ready to regard his teaching problems as experimental problems, to be solved by variation of methods with systematic testing and selection.

TRAINING. — For success in high school science work profound learning and research ability are not required, but common sense and sound scholarship are. The teacher should know well and thoroughly the science or sciences that he is teaching, and should keep his knowledge up to date in every phase of it that touches his teaching. Beyond this

his knowledge is better if it be extensive rather than intensive ; for he should have a fair acquaintance with the other sciences and the relations of the others to his own. He should have a ready command of correct English, and should have mastered the elementary principles of modern inductive logic as applied in the scientific method. If he teaches physics, or indeed chemistry either, he must also know mathematics well, — the more he knows of it the better, for he cannot grow in scholarship in his subject without the higher mathematics. All teachers of science, but especially those who teach physics and chemistry, should be able to make photographs and lantern slides, to operate a projecting lantern, and to use at least the simpler kinds of tools. A teacher of physics, especially, who cannot construct simple apparatus and make ordinary repairs is incompetent. So also is a teacher of biology who is not reasonably expert in the use and care of a microscope and the technique of making sections and mounting them on slides. Some ability to draw and a considerable amount of skill in experimentation are also indispensable to success in any branch of science. So also every teacher of science should have a thorough up-to-date knowledge of elementary psychology and the principles of teaching. These are the essentials. Whatever else the teacher has obtained in the way of general culture and special training is all to the good. With rare exceptions the requisite training cannot be acquired otherwise than by four years of college or normal school study under teachers who have themselves had advanced university work. In addition to major work in the subjects he is to teach, the secondary science teacher should have minor work in at least one biological science, one earth science, and one physical science, and courses on the teaching of his own subject or subjects. No man or woman who is honest will be satisfied to continue in the work unless he has had this minimum of training or is persistently and systematically working towards it. A college degree is

not essential, but an amount of training which it is supposed to represent is absolutely necessary.

PROFESSIONAL SPIRIT. — The teacher of science should also be a diligent reader of the literature of his subject. He should support by his subscription and read *School Science and Mathematics*, should keep up in a general way with the progress of science through *Science, Nature*, or *Science Abstracts*, and if possible should read some of the articles in the professional scientific journals or proceedings of the national societies of scientists who are specialists in the branch that he is teaching. He should also read whatever books there are on the pedagogy of his subject. Whenever he can do so, he ought to attend the national or local meetings of scientific societies and associations of teachers where science and science teaching are discussed, and give himself the opportunity to meet the leading workers in his field and catch the inspiration that such contact affords. Finally, as a citizen and a representative of science in his community, the science teacher, when he can occasionally, ought willingly to respond to an invitation to give an illustrated popular lecture on some phase of his subject; and if he is making some experiments in methods of presentation or has hit upon some new laboratory device or experiment that others would be helped by knowing about, he should write a description of it for *School Science and Mathematics*. No teacher will be able for long to inspire his pupils with the love of study unless he is himself an earnest student and an active professional worker.

TOPICS FOR FURTHER STUDY

1. Can the antithesis between the standpoint of a "liberal" and a "vocational" aim in education be reconciled in the teaching of the sciences by the method of the problem approach? Cf. Bagley, W. C., *The Educative Process*, Chap. III, and Snedden, David, *The Problem of Vocational Education*, Houghton Mifflin Co., Boston, 1910, pp. 1-8, 26-34, 71-74, 81.
2. From your own standpoint, compare and criticize the views of

Herbert Spencer in his *Education*, Chap. I, of Huxley in his *Science and Education*, Chaps. IV, V, and VI, and of Matthew Arnold in his *Essays in Criticism*, pp. 37 ff. Can the different ideas be reconciled? How? If not, where does the truth lie?

3. What possibilities does geography possess for developing the right social and moral attitudes in adolescents? See Dewey, John, *Moral Principles of Education*, Houghton Mifflin Co., Boston, 1909, Chap. IV, and his *School and Society*, University of Chicago Press, 1913, Chap. I.

4. Should we try to "create interest" in a new topic of science, or to find in it something which connects with the interests of the pupils? See Dewey, John, *Interest and Effort*, Houghton Mifflin Co., Boston, 1913, Chap. II, especially pp. 23, 25, 33-35, 41-45, 86-89.

5. Make a list of life situations, in the occupations of some of your acquaintances, in which the specific habits that should be formed in the sciences that you have pursued would probably function.

6. Make a similar list for concepts and ideals of methodical procedure.

7. Make a bibliography of books that should be in every school library, as supplementary reading for pupils in the various sciences, especially such books as may have inspirational value.

8. Choose any topic with which you are familiar and make a detailed lesson plan for teaching it. Include plans for field or laboratory work in connection with the class conference.

9. In several textbooks on any one science apply the criteria for choice of subject matter; and find the ratio or percentage that you would retain. Limit the study to one group of topics, and estimate the amounts in lines of print.

10. Choose a topic in any one science, and make a list of the information on this topic that would probably be possessed as a result of previous experience by the majority of a class of city children. Make a similar list appropriate to a class of village or country children. Make out a list of easy questions which when put to the individuals of the class would reveal their knowledge or ignorance of the information that you have listed. Such a list could be used for testing the actual status of the class when beginning the topic. The same list, given after the study of the topic, could be used to compare their status after the training with their status before the training.

11. Write out as good a statement as you can of your concept of adolescence; read Professor Whipple's chapter on that subject in this book with a view to converting your psychological concept into a logical one; then make a written statement of your new, or logical, concept, and compare it part by part with the former. Formulate your concept of the scientific method of study in about 250 to 500 words.

12. Make a sketch plan to scale for a physics or chemistry classroom and laboratory combined, with a stockroom and photographic dark room in connection. Plan a similar room for biology and geography. Plan a layout of rooms for two of the sciences, consisting of two laboratories with a classroom between, and providing for storage room for apparatus and supplies.

13. Compare your experiences in learning history or studying a dramatic selection by the textbook-lesson-and-recitation method with your experiences in working up a topic for a debate or a part which is to be acted in a play. Make an estimate of the relative amount of interest taken in the two kinds of learning and the relative amount of useful material retained in memory. Compare also the relative amounts of interest displayed by your classmates. Do the same in the case of a textbook science recitation and a laboratory exercise in which you were set to find out something that seemed to you to be worth while finding out.

14. Read an article in the *National Geographic Magazine* and try to recollect, as you go along, what actual experiences and observations of yours help you to form a clear mental picture of the places, scenes, and relations described. Can you find data from your own experience to support the arguments of this chapter for the approach of topics in geography, or history and civics, from the "human" standpoint, and through local problems? To justify class excursions and field work in the sciences?

15. To what extent may collections of postcards, pictures from magazines, and advertising matter be used as class and laboratory illustrations? Outline a plan for mounting and filing such material.

16. Make a list of the ways in which man controls the forces of nature for his own purposes in your home locality.

17. How much relative importance do you attach to analyzing plants and making herbaria, as compared with gaining experimental knowledge of how plants grow and behave? As compared with knowledge of forestry, or of methods of testing seed corn?

18. Many teachers are advocating "general science" courses in the first year of high school. What are the arguments for and against such courses?

19. Admitting that a "general science" course should be introduced in your home school, should it consist of equal portions culled from all the sciences, or of a series of problems drawn from the local environment and its industries, or of a core of a single science (say physical geography, physiology, or biology, or agriculture) with material from the other sciences brought in and taught when needed for a broader and clearer

understanding of the science adopted as the core? For references see the files of *School Science and Mathematics*, and the *Proceedings of the National Education Association*.

20. Outline a plan for coöperation between teachers for correlating geography and history, geography and biology, physics and mathematics, physics and chemistry, physics and physiology, household arts or manual training with any of the sciences.

21. Choose a chapter in any science textbook and make an estimate of the relative emphasis that should be placed on each topic by arranging the topics in a list according to their relative worth from the standpoint of the pupils in your home community who do not expect to go to college. Assuming that you were a college teacher of the same subject, rank the topics again with reference to their importance for the students who are to continue the subject under you in college. What per cent of the topics are changed in relative rank? On what grounds did you make each change? Debate these grounds with others who are interested in the same problem.

22. Is it correct or incorrect for a textbook to state a theory or law first and then justify it by illustrations? Does the fact that the majority of authors do this prove that it is correct? Can you bring forward real arguments to defend this practice? Can you bring forward valid arguments to show that it is wrong? If compelled to use a textbook built after this plan, in what way would you use it? Illustrate by a particular book and lesson.

23. In starting a new subject with a class is it better to begin studying *about* the subject, or to begin at once to study some thing or problem *in* the subject?

24. At what point in the study of geography would you introduce the concept of base level of erosion? of a peneplain? of a geographical cycle? Of what use are these concepts in a humanistic treatment of geography? Answer the same questions for the principle of the conservation of energy and the molecular theory in physics, for chemical equations, the law of the conservation of mass and the atomic theory in chemistry, and for the cell theory and the principle of evolution in biology.

25. Make out a plan for your professional study for the next five years.

REFERENCES

Geography

- BRIGHAM, A. P. *Geographic Influences in American History*. Boston, 1903.
- CHAMBERLAIN, JAMES F. Report of the N. E. A. Committee of 1909 on Secondary School Geography. *Jour. of Geog.*, 8: 1-9, September, 1909. Also *Proc. N. E. A.*, 1909, p. 820.
- DAVIS, W. M. *Geographical Essays*. Ginn, Boston, 1908.
- DAVIS, KING, and COLLIE. *The Use of Government Maps in Schools*. Holt, New York. (Price 30 cents. Indispensable to teachers.)
- DODGE, R. E. Geography for Secondary Schools. *Jour. of Geog.*, 7: 121-125, February, 1909.
- DODGE, R. E., and KIRCHWEY, C. B. *Teaching of Geography in Elementary Schools*. Rand, McNally, Chicago, 1913. (High school teachers will find this exceedingly helpful, especially the bibliographies.)
- GENTHE, M. K. Geographical Text-books and Geographical Teaching. *Jour. of Geog.*, 2: 227-243, 360-368, May and September, 1903. (A critical discussion of methods and textbooks.)
- GREGORY, KELLER, and BISHOP. *Physical and Commercial Geography*. Ginn, Boston, 1910. (College text, correlating the two phases of geography from the humanistic standpoint.)
- Journal of Geography* (monthly). Madison, Wis.
- MILL, R. H. *Guide to Geographical Books and Appliances*. George Philip & Son, London, England, 1910. (Most complete bibliography of the kind in English.)
- MILL, R. H. (editor). *The International Geography*. Appleton, New York. (Comprehensive regional treatment of the continents, exceedingly valuable and highly authoritative.)
- National Geographic Magazine* (monthly). The National Geographic Society, Washington, D.C.
- REDWAY, J. W. *The New Basis of Geography*. Macmillan, New York, 1901. (A manual for the preparation of teachers, with bibliography.)
- SALISBURY, R. D. *Physiography*. Holt, New York. (College text, comprehensive and very suggestive.)
- SEMPLER, E. C. *American History and its Geographic Conditions*. Houghton Mifflin Co., Boston, 1903.
- SUTHERLAND, W. J. *The Teaching of Geography*. Scott, Foresman & Co., Chicago, 1909. (Treats of general and special method, equipment, etc. Is psychologically sound. Contains extensive bibliography, selected with great care.)

- WHITBECK, R. H., and MARTIN, L. The High School Course in Geography. *Bull. of the Univ. of Wisconsin*, No. 382, High School Series, No. 10, Madison, Wis., 1910. (Up-to-date treatment of subject matter and methods of teaching. Excellent bibliography. An exceedingly valuable pamphlet.)

Biology

- American Naturalist* (monthly). Ginn, Boston.
- BAILEY, L. H. *The Nature Study Idea*. Doubleday, New York, 1903.
- Bird Lore* (bi-monthly). Macmillan, New York.
- Botanical Gazette* (monthly). University of Chicago Press.
- CLODD, E. *Pioneers of Evolution*. Appleton, New York, 1897.
- GANONG, W. F. *The Teaching Botanist*. Macmillan, New York, 1910. (With excellent bibliography, outlines of work, experiments, and other information indispensable to teachers of botany.)
- HEALD, F. D. Botany in the High School. Botany Section of *Bull. of the Univ. of Texas*, No. 150, Austin, Tex., 1910. (Well-selected bibliography, and outline of subject matter.)
- HODGE, C. F. *Nature Study and Life*. Ginn, Boston, 1902.
- LLOYD, F. E., and BIGELOW, M. A. *The Teaching of Biology*. Longmans, 1907. (With extended special and general bibliographies, and full discussion of laboratory methods and equipment.)
- Plant World* (monthly). Desert Laboratory, Tucson, Ariz.
- Report of Committee on United States Government Publications usable in Secondary Schools*. *Proc. N. E. A.*, 1909, p. 802.
- SHALER, N. S. *Domesticated Animals, their Relations to Man, and his Advancement in Civilization*. Scribners, New York, 1895.
- THOMSON, J. A. *The Science of Life*. Stone, Chicago, 1899.
- VON SACHS, JULIUS. *History of Botany*. Clarendon Press, Oxford, England, 1890.

Physics

- CAJORI, FLORIAN. *History of Physics*. Macmillan, New York, 1899.
- DEWEY, JOHN. Science as Subject Matter and Method. *Science*, 31: 121-127, January 28, 1910.
- FRANKLIN, W. S. The Study of Science by Young People. *Bull. No. 431, N. Y. State Dept. of Education*, September 15, 1908.
- GARNETT, WILLIAM. *Heroes of Science — Physicists*. E. & J. B. Young. New York, 1885. (Popular and accurate.)
- JORDAN, DAVID STARR. The High School Course. *Popular Science Monthly*, 73: 28-31, July, 1908.

- MACH, E. *The Science of Mechanics*. Open Court Pub. Co., Chicago, 1893.
- MANN, C. R., and TWISS, G. R. *Physics*. (Revised.) Scott, Foresman & Co., Chicago, 1910. (A high school text in which the ideas advanced in this chapter are worked out for classroom use.)
- MANN, C. R. *The Teaching of Physics*. Macmillan, New York, 1912. (Psychologically sound, very readable, and exceedingly suggestive. Valuable bibliographies.)
- Science Abstracts, Section A — Physics*. Spon & Chamberlain, New York. (The best single publication for keeping up with the progress of research and discovery in physics.)
- Scientific American and Scientific American Supplement*. New York.
- SHUSTER, A. *The Progress of Physics during Thirty-three Years*, University Press, Cambridge, England, 1911.
- SMITH, A., and HALL, E. H. (See under Chemistry. The part by Professor Hall contains much information of value to teachers of physics, including bibliographies.)
- STALLO, J. B. *The Concepts and Theories of Modern Physics*. Appleton, New York, 1897.
- Symposium on the Purpose and Organization of Physics Teaching. Avery, L. B. — Baldwin, J. Mark — Butler, Nicholas Murray — Chute, H. N. — Crew, Henry — Dewey, John — Hall, G. Stanley — Michelson, Albert A. — Millikan, R. A. — Strong, E. A. — Terry, H. L. — Twiss, G. R. — Woodhull, John F.; *School Science and Mathematics*, December, 1908 and January, February, and March, 1909. (Published also in pamphlet, price 10 cents.)
- TERRY, H. L. The New Movement in Physics Teaching. *Educational Review*, 37: 12-18, January, 1909.
- THORNDIKE, E. L. Science Teaching as seen from the Outside. *Bull. No. 34, N. Y. State Dept. of Education*, August, 1907.
- TWISS, G. R. *Laboratory Exercises in Physics*. Scott, Foresman & Co., Chicago, 1906. (This manual is not fully up to date from the author's present point of view; and a few of the experiments in it would now be rejected by him; but it contains an abundance of others which are entirely satisfactory, and give excellent results with the pupils. Contains many valuable hints to teachers on laboratory work and equipment.)
- WATSON, W. *A Text-book of Physics*. Longmans, New York, 1907. (A well-balanced college text, very readable.)
- WOODHULL, JOHN F. Science for Culture. *School Science and Mathematics*, 7: 83-93, February, 1907. Also in *School Review*, Chicago, February, 1907.

Chemistry

- BAUER, HUGO. *A History of Chemistry*. Longmans, New York, 1907.
- BURNS, E. E. *Story of Great Inventions*. Harpers, New York, 1910.
- FREUND, IDA. *The Study of Chemical Composition*. The University Press, Cambridge, England, 1904. (An advanced account of the method and historical development of theoretical chemistry. Exceedingly valuable to the teacher who would learn the true spirit and method of science as well as the theories, past and present, that have helped to advance chemical knowledge.)
- REMSEN, IRA. *Organic Chemistry*. Heath, Boston, 1909.
- ROSCOE, H. E. *John Dalton and the Rise of Modern Chemistry*. Macmillan, New York, 1895.
- SCHOCH, E. P. *Chemistry in High Schools*. *Bull. Univ. of Texas*, No. 210, Austin, Tex., 1911. (Hints on methods and equipment, excellent.)
- SMITH, A., and HALL, E. H. *The Teaching of Chemistry and Physics*. Longmans, New York, 1904. (A very complete treatment, as to chemistry, both philosophical and pedagogical, including methods of laboratory management and equipment, and extended bibliographies.)
- SMITH, A. *Inorganic Chemistry*. The Century Co., New York.
Laboratory Outline of General Chemistry. The Century Co., New York.
- THORPE, T. E. *Essays in Historical Chemistry*. Macmillan, New York, 1894.
- VAN'T HOFF, J. H. *Physical Chemistry in the Service of the Sciences*. University of Chicago Press, 1903.
- VON MEYER, ERNEST. *A History of Chemistry*, from the earliest times to the present day, being also an introduction to the study of the science. Macmillan, New York, 1898.
- WEICHMANN, F. G. *Science Sketches, Chemistry*. Wm. R. Jenkins, New York, 1899. "Very readable and very good."

CHAPTER XIII

MATHEMATICS

NATURE AND USE OF THE SUBJECT. — Attempts to define so broad a subject as mathematics have not been very successful. Benjamin Peirce, one of the best of the American-trained mathematicians, said that “mathematics is the science that draws necessary conclusions.” Such a definition trespasses upon the domain of logic; but there are many who would relate logic and mathematics, as sciences, more closely than is commonly done. Professor Bôcher has suggested a basis of definition: “We may seek some hidden resemblance in the various objects of mathematical investigation, and, having found an aspect common to them all, we may fix on this as the one true object of mathematical study. Or we may abandon the attempt to characterize mathematics by means of its *objects of study*, and seek in its *methods* its distinguishing characteristic. Finally there is the possibility of combining these two points of view.” When, however, we attempt to define the science with respect to its objects, we are confronted by so many difficulties that there seems but little hope of success. There seems more chance of favorable results in attempting to define the science by means of methods, and numerous efforts in this direction have been made. Professor J. W. Young has recently suggested the defining of “abstract mathematical system” as a system of symbols devoid of content except such as is implied in the assumptions concerning them, and then saying that “mathematics as a whole might then be defined as consisting of all such abstract mathematical systems together with

all their concrete applications." These attempts at defining the science serve at least to show the broadening of the subject from century to century.

Reasons for its Study. — With this broadening of the science itself has come not merely the difficulty of definition, but also the difficulty of stating in concise terms the certain reasons for studying the subject. We may set forth certain reasons for studying this phase or that, but for studying a science that is so broad that we can hardly define it, and so far-reaching in its applications, it is manifestly well-nigh impossible.

In the elementary portions of the general field it is possible to assign some reasons for studying the science. Among these, utility stands out prominently, and indeed there are few parts of mathematics that have not very definite applications to some other line of science or to some of the arts. Not only is there the definite application of the present to be considered, but there is potential application. No one thought when complex numbers were first suggested that they would in our day play a part in the theory of electricity, for example; nor did the Egyptians and Greeks see in their shadow reckoning the forerunner of the trigonometry that uses the slide rule and logarithms in its computations, as at present. Certain of the reasons for the study of mathematics are set forth under the various branches considered later.

Branches of the Subject. — There is no well-defined basis for the satisfactory classification of the branches of mathematics. Indeed, the modern tendency is toward the uniting of these branches rather than their differentiation. In elementary mathematics this tendency shows itself in the use of the simple equation and the introduction of mensuration in arithmetic; in the use of the facts of mensuration thus learned in algebra; in the use of algebra in the elementary course in geometry; and in the use of both algebra and geometry to a greater extent than formerly in trigonometry. Many would like to see the union of elementary mathematics made

still more close, and it is probable that the interrelation of algebra and geometry will become more and more pronounced, not in their complete fusion, since the methods of reasoning vary so much in the two branches, but in the emphasizing of the natural points of contact.

Range of Secondary Mathematics. — At present in America secondary mathematics includes algebra, geometry, and trigonometry. It is probable that, in the natural course of evolution, this conception of the subject will be changed to harmonize with world experience. There is no reason why a fair working knowledge of the algebra and geometry of the artisan should not be given in Grades VII and VIII, where at the present time the mathematics is chiefly sociology and a low grade of economics, — the subject of taxation, for example, having practically no mathematics left in it. There is no reason why, at the end of Grade IX, a pupil should not know what algebra and geometry mean and how to solve the ordinary problems of mensuration by trigonometry. In the next two years the pupil should be allowed to elect algebra, geometry, and trigonometry, the experience of the world showing that this work can easily be covered at this time. In the twelfth school year a fair idea of the calculus and mechanics can be given, and is given in many parts of the world. The future may reasonably have this in store for American pupils, but it is a matter of slow preparation to get teachers ready for such work.

ALGEBRA. General Nature of the Subject. — The term algebra has had several meanings in the development of the subject as we now understand it, and even at present it is used in a rather undefined sense. As first used, the term referred to the science of the equation, as will be seen in the remarks below on the history of algebra. With the development of symbolism it came to refer to that part of mathematics which teaches the use of letters to represent numbers, not merely in equations but in operations essential to the

study of more advanced mathematics, such as the fundamental operations resembling those of arithmetic. Among the various attempts to define algebra may be mentioned Newton's characterization of the subject as "universal arithmetic," the more common one of "generalized arithmetic," and Comte's expression, the "calculus of functions," as distinguished from arithmetic, which is the "calculus of values." None of these attempts is more than a mere epigram. The fact is that mathematicians do not find it necessary or profitable to attempt any exact definition of the science. It is the calculus of certain functions, and in general these functions are those involving addition and an inverse, multiplication and an inverse, involution and an inverse. Thus, besides $a + b = c$ we have $a = c - b$, and $b = c - a$; besides $ab = c$ we have $a = c \div b$, $b = c \div a$; besides $a^b = c$ we have $a = \sqrt[b]{c}$, but $b = \log c \div \log a$ is commonly excluded from elementary algebra, and $\log a$ is not considered as an algebraic number. Algebra is commonly considered at present to mean that part of mathematics which uses letters to represent numbers, which treats of the operations of arithmetic performed with numbers represented in this manner, and which emphasizes the use of the equation. Higher algebra is taken to include such topics as symmetric functions, power sums, the proof of the fact that every algebraic equation has a root, number congruences, continued fractions, determinants, and various other theories needed in advanced work.

Reasons for Studying Algebra. — There has of late been some justifiable criticism of the conventional teaching of algebra as the subject has come down to us. This has been accompanied, as is usual in such movements, by the attack of the extremist who would like to do away with the subject altogether. Each of these movements is worthy of attention, and the essential feature of any reply must ultimately rest upon the reasons for the study of algebra. There are those

who object to the reasons usually given because they are too numerous, as if the varied reasons that a boy has for loving his mother should be adduced to show that he does not love her at all, or should not love her. There are various reasons for studying algebra, as for studying every other subject, and most of those which are advanced have a good basis.

Limiting ourselves to a few of the more important reasons why every pupil, girl as well as boy, should study the subject, it may first be said that general information requires it. If mathematics did not touch every great business enterprise, all kinds of engineering, all our conception of the infinite about us, all great industries, the work of the twentieth-century artisan, the navigation of the ships, and the building of aëroplanes, then it might be treated as a luxury for the scholar alone; but mathematics does touch all these lines of mental and manual activity, and hence it is a subject about which every person should be somewhat informed, just as every person should be informed about the growth of industry, the emancipation of labor, the history of invention, and his duties to his fellows.

But is algebra of enough importance to be included in a course of study for the reason given above? To-day, yes; the question was more debatable yesterday. To-day there is no artisan who takes a trade journal or who reads a manual devoted to his line of work who does not meet the formula and who does not need to know how to evaluate and manipulate it. To-day is a day of encyclopedias, but no mechanic reads an article on his subject without finding that he must know the universal language of algebra. The rules of diet and the laws of sanitation, in which the woman is coming to be an expert, are now stated in algebraic terms. Statistics are given in graphs, conclusions from these statistics appear in formulas, simple rules of physics are given as equations, and a knowledge of this language is essential to even a fair degree of education.

This, however, is not the inherited algebra, and it is the latter which is open to criticism rather than the algebra of the future. And yet the inherited subject has some undisputed value. It gives facility in the manipulation of algebraic expressions which is helpful in the kind of work already mentioned, and which has the interest of variety. The pupil becomes a master of elementary technique by this manipulation, and this technique is valuable to him whether he uses it only as the artisan may, or proceeds to higher mathematics.

For the girl, who is the one who will direct the education of the children of the next generation, — her own children or those of others, — an all-round education is imperative. The father may be narrow in his training, but the mother must have touched all the great lines of intellectual activity if she is to guide her children intelligently.

There are various other important reasons for studying algebra, such as the influence of exact truth upon character formation. How much of this can be carried over into the daily action has never yet been measured, and probably it never will be weighed with absolute accuracy. That this influence is real, however, seems undeniable. Furthermore, the habits of orderly arrangement, of logical argument, of constantly checking one's conclusions, and of terseness of expression that are acquired in the study of algebra, seem to be attributes which carry over from this domain to other lines of intellectual activity.

Teachers of algebra are realizing the new demands upon the subject and the new possibilities before them, and with this realization is coming, by the ordinary process of evolution, a better science of mathematics.

Present Status in the Curriculum. — In the schools of the United States algebra is at present generally taught in the first year of a four-year high school course, or in the ninth school year beyond the kindergarten, and in half of the eleventh school year. The general plan is to cover the four fundamental

operations with integers and fractions, factoring, powers and roots, linear equations with one, two, or three unknown quantities, and quadratic equations with one unknown quantity. This year of work is generally followed by a year in plane geometry. Half of the next year, the eleventh in the pupil's course, is usually devoted to algebra, reviewing the preceding work and completing the elementary work through quadratic equations with two unknown quantities, including easy radical equations.

There is at present a strong movement in favor of using the linear equation with one unknown quantity, and also simple formulas in algebraic language, in the work in arithmetic in the elementary grades, and in particular in the seventh and eighth school years. There is also a very marked tendency to change the traditional high school course of four years to a course of five or six years, beginning in the eighth or seventh school year. The effect of this plan will be to complete the essentials of arithmetic in the elementary school (the first six school years), to review arithmetic in the high school (the second six school years), and to extend the instruction in algebra over a longer period. This might profitably be done without taking any more time for mathematics than at present. The result, if we can secure as good candidates for teaching as are secured in the older countries, will be a much better training in algebra before the pupil enters college or goes into business.

The textbook in elementary algebra is merely a development of the sixteenth-century textbook in arithmetic. One of the first successful works of this kind was the *Algebra* by Christopher Clavius, a Jesuit teacher, who went from Germany to Rome and published this textbook in 1608. The general plan of the book is similar to that of his *Epitome Arithmeticae Practicae*, which appeared in 1583 and which went through several editions, — first notation, then the operations with integers, then fractions, and then equations.

There has of late been a tendency to change this plan, and to introduce algebra by showing the uses of the formula and of the linear equation with one unknown quantity; in other words, to make the transition from arithmetic to algebra less marked.

In European Schools. — In the European schools it is the custom to introduce abstract algebra earlier than is usually the case in America. This is accomplished by combining it with arithmetic more fully than is done here; by having less arithmetic taught, partly because of the freedom on the continent, from the difficult system of compound numbers that is still used in England, Canada, and the United States; and by having more vigorous teaching than is the general custom in the western hemisphere. Thus in the *Normallehrplan des Gymnasiums* of Austria, of 1909, algebraic notation, the negative number, and the geometric-algebraic significance of $(a + b)$, $(a - b)^2$, $(a + b)(a - b)$, $(a + b)^3$, etc., are introduced in the sixth school year. In the seventh school year linear equations with several unknowns and the quadratic equation with one unknown are studied. In the eighth year this work is elaborated, and in the ninth year, at a time when the American schools are usually beginning algebra, the subjects of logarithms, complex numbers, and the easier forms of higher equations are being studied. A somewhat similar state of advancement is seen in the curricula of several of the German states, in many of the English schools, and in the mathematical classes of France. These facts have raised the question as to whether the schools of America are utilizing to the best advantage the time assigned to mathematics.

GEOMETRY. — Etymologically, the word means earth measure, from the Greek, $\gamma\eta$, $g\bar{e}$, earth + $\mu\acute{\epsilon}\tau\rho\nu$, *metron*, measure. It has come, however, to mean the general science of form, the words "surveying" and "geodesy" being applied to the measuring of the earth.

Reasons for Studying Geometry. — It has always been held that geometry is studied because of a peculiar training and pleasure that this science gives, and that other sciences do not give, at least in the same degree. With the investigations of modern psychologists there has come a doubt as to the value of the training that it gives, and this has led many emotional followers of new doctrines to proclaim that geometry has no such claim upon the pupil's time as the advocates of this value assert. Modern educators do not claim, however, that geometry has no value *per se*, but rather that the methods of presenting the subject that have obtained in the past can be improved, and that certain of the values formerly claimed for it do not exist. To this the more thoughtful teachers of the subject have long since assented. For example, it was poor policy to memorize all of geometry, for this plan took away the pleasure of the study, and it did not give the pupil any power that he could carry over into other lines of work, save as he acquired facts which he could have obtained as well without the labor of memorizing the proofs of Euclid.

The advocates of a substantial geometry, as opposed to the mere acquisition of a few rules of mensuration, claim that the study of geometry brings great pleasure and an inspiring mental uplift, when the subject is properly presented. They place it in this respect upon a plane similar to that upon which the study of literature and music rests. They claim further that through geometry a student acquires a knowledge of space relations that he does not acquire from other subjects, which knowledge he carries over into the study of the graphic and plastic arts, of geography and astronomy, and of the science of mechanics. They also assert that geometry is the only subject in the secondary curriculum that gives a specific training in deductive logic, and that this training gives a habit of thought that is carried over into other lines of mental activity. And finally they claim that habits of

persistence, of using only the necessary steps in an argument, of holding to that which is true, of seeking for exact truth, and of arranging work in logical order, are instilled by the study of geometry, and that these habits are unconsciously transferred to other fields of work. In other words, they claim that the pleasure and the profit of approach to exact truth give a power that makes the pupil stronger in his other activities. This claim is sanctioned by the opinions of most people who have studied geometry under a worthy teacher, and no investigations thus far made have shaken it. The statement that geometry has no value as a mental discipline is usually found to mean that there is no such thing as mental discipline as defined by the antagonist, to which most people would heartily agree.

Present Status of the Teaching of Geometry. — Plane geometry is now commonly taught in the United States in the tenth school year, the second year of a four-year high school. This is usually followed by a half year of solid geometry, frequently elective. It is not the universal custom to finish all of plane geometry in a single year, although this is done in many of the best schools, and it probably represents the future curriculum as to the amount of time to be allowed to the subject. There is at present a tendency to reduce the number of basal propositions and to increase the number of exercises, so as to give a student more opportunity for independent work. The eastern colleges do not require solid geometry for entrance to the arts course, while the western ones frequently do require it. This means that more work is covered in plane geometry in the secondary schools of the eastern states, the amount of time spent on the entire subject of geometry being about the same. From every standpoint it would be better that a pupil should sacrifice a certain amount of plane geometry for the purpose of having an introduction to solid geometry, if he could acquire the latter only in this manner.

Certain attempts have been made to teach algebra and geometry simultaneously, or even to fuse them into a single subject. This has usually met with only sporadic success. That the foreign schools have usually run geometry over several years, as opposed to the American plan, is liable to be misunderstood. Where serious demonstrative geometry has been begun early and extended over several years, the results have not been satisfactory. Usually the early geometry has been mere mensuration, a subject that is taught in the American arithmetic, and that is coming to be very satisfactorily taught. It may therefore be said that in America geometry extends over several years, culminating in a year or a year and a half of serious demonstrative work. That the earlier work is capable of great improvement is, however, apparent. As to the fusing of the two subjects of algebra and geometry in one, this seems destined to meet with success only in schools in which nothing but a little practical geometry is studied.

The question of the nature of the textbook is one that is periodically agitated. Several types have been suggested: (1) A book with the basal proofs substantially in full, to serve as models, and a large number of well-graded exercises for original work; (2) a syllabus of basal propositions; (3) a book of suggested proofs, heuristic in nature. Of these the first has been the one almost universally used, the objections to it having little force with a good teacher, and the other forms being useless with a poor teacher.

Reforms and Improvements. — Numerous reforms and improvements are being suggested for the treatment of geometry at the present time, and a few of these will be mentioned. (1) That geometry and algebra be fused into a single subject, an effort that takes no account of the fact that the two subjects are distinct in purpose, in results, and in difficulty, and that each has a peculiar interest that is lost when it sacrifices its individuality. (2) That the two subjects be taught simul-

taneously, two days of one and three of the other during each school week. This has often been tried in the United States, but in the main with unsatisfactory results, not because the plan is unsound, but because of our system. Psychologically the argument is that the pupil is not mature enough for this plan, his interest being better maintained by concentrating his energy on either the one or the other. The argument that he would see the relation of one science to the other better by the simultaneous than the tandem arrangement is partly offset by the custom of the best teachers to bring into algebra as much of the mensuration learned in arithmetic as possible, and to introduce into geometry as many applications of algebra as seem adapted to this purpose. The plan will probably succeed in America, as it has elsewhere, when the high school controls the teaching in Grades VII and VIII. (3) That geometry be converted into an applied science, joining the general industrial movement of the present. This would mean that geometry would cease to exist, since the applications of the subject are merely the rules of mensuration learned in arithmetic, and learned by a natural form of induction. If geometry were abolished, it would be possible to introduce other lines of mathematics, such as trigonometry (which requires only very little geometry), calculus (which requires practically no geometry beyond elementary mensuration for a large number of its applications), and some little work in the practical problems of vector analysis. For the great majority of students this seems unwise, since they have little interest in these applications, but in certain forms of technical high schools such an arrangement may prove necessary. (4) That algebra be taught for a half year, followed by geometry for the same length of time, and this by another half year of algebra, followed again by a half year of geometry. This plan has certain advantages over the year arrangement, but as yet it has to justify itself, the general feeling being that the pupil would lose more in immediate

interest in a topic than he would gain in sustained interest in mathematics as a whole.

While these suggestions for reform are open to question, other reforms are meeting with general acceptance and are improving the current teaching of geometry. (1) It is universally agreed that Euclid is undesirable as a textbook for beginners, and, even in England where it has so long been the standard, it is now superseded by books more suited to the youthful mind. (2) The propositions of the textbook are coming to be considered more in the light of basal truths, and the proofs as models, and the serious work of the pupils is coming to be more and more in the realm of exercises. (3) The exercises are coming to be more carefully grouped and graded. (4) Such legitimate applications as can be found, and as give interest to the study of geometry, are being sought for and introduced. (5) More attention is being given to geometric design, so long as this does not detract from the scientific work. (6) The rôle of intuition is more evident. In brief, serious effort is being made to make geometry more interesting and useful, and to recognize its game element and its utility, without destroying the values that have long made it a recognized standard subject in the curriculum.

ALGEBRA AND GEOMETRY IN THE GRAMMAR GRADES. — The idea of introducing algebra and geometry in the elementary school arose from the feeling that too much arithmetic was required and that the foreign mathematical curriculum might profitably replace the American. By the foreign plan, less arithmetic has been required than in the United States, allowing time for some work in literal notation at least, and in some form of geometry.

The idea is plausible, but like all new ideas it has not been sufficiently considered by some of its advocates. Granted that there is some time available for algebra and geometry in the last six years of the elementary school, what should be the nature of this work?

As to algebra, the first experiments led to an attempt to use a considerable amount of literal notation simply because it was part of algebra. Removing of signs of aggregation, performing the various operations with integers and fractions, and the solution of a rather meaningless lot of equations, formed the body of the early work as attempted abroad and in America. This has, more recently, given place to a more rational use of algebra as a part of arithmetic. The use of x in a simple equation has come to be allowed in the solution of arithmetical problems, to the material benefit of arithmetic. The use of the formula, in the ordinary algebraic symbolism, has come to be a recognized part of arithmetic, as in $a = \pi r^2$. In other words, the part of algebra that throws light upon and correlates with arithmetic has been adopted, not as a separate subject, but as something to be assimilated with the older science.

There are, however, many schools in which it seems best to introduce an elementary textbook in algebra in the seventh or eighth school year, replacing the arithmetic entirely. For such schools several good manuals of elementary algebra have been prepared. The best of these begin by showing the practical uses of algebra, usually in formulas with which the pupils are familiar. They then show the use of the simple equation in the solution of the problems of ordinary arithmetic. This is followed by the nature of the negative number and its practical applications. The fundamental operations with integers and fractions are treated in a simple fashion, and the work closes with further practical problems in simple equations and easy quadratics.

Each of these plans is usable, and each is adapted to particular types of school. The plan of introducing the abstract algebra of the high school into the elementary grades is not, however, to be commended.

The introduction of demonstrative geometry into the elementary grades has not been so successful. It is true that

in the best English schools Euclid has been taught in what we would call the grammar grades, but this does not appeal to American teachers as an educational policy to be followed. The work is too abstract and too logical to be understood, and the gain of mere memorizing is offset by the loss in interest. Recently in England there has been a great improvement in this respect, some excellent propædeutic work being done in algebra and geometry. In Germany, there are some good textbooks in demonstrative geometry, adapted to the grades. These, however, do not appeal to the American teacher as usable here. While better for the purpose than Euclid, they are lacking in interest and in motive. It is a mistake, however, to feel that America has done nothing in this field. There has always been a considerable amount of work in mensuration in our arithmetics. Formerly this was, like arithmetic in general, merely a matter of rule; but for some years back there has been a successful effort made to render this work clear to the understanding, intuitional if not logical in the formal sense. As a result, the work in mensuration now given in the best American arithmetics seems a very satisfactory solution of the problem of introducing some geometry into the grades, until the time when the high school department of mathematics takes over the work.

Efforts have been made, but with no marked success, to construct a geometry suited to the grammar grades. These have thus far taken the form of textbooks on constructive geometry, on observational geometry, and on an elementary type of demonstrative geometry. These works serve a good purpose in that teachers see how to make the subject of mensuration more real, but they have not had any marked influence beyond this point. Further improvement in the field of geometry in the grades seems to lie (1) in the securing of a larger number of practical problems in mensuration, adapted to the interests of the children, and possibly (2) in

the preparation of a textbook in geometry similar to the several textbooks in algebra for beginners.

Looking to the ideal arrangement, we should all hope for the beginning of intuitive geometry in Grade VII, or earlier, to be followed by the algebra of the formula and equation as soon as the need arises, and certainly in Grade VIII. In Grade IX formal algebra and formal geometry may be given. Thus every child would come to know mathematics in its general bearing, and to know what algebra and real geometry mean. Thereafter the subject may be elective, for the door has now been opened and the youth may enter or not as he pleases. The intellectual type will continue in such subjects as mathematics, sciences, history, and languages, while the non-intellectual type will be content with other fields of activity.

College Entrance Requirements in Mathematics. — The entrance requirements in mathematics in the American college were very limited until well into the nineteenth century. At present there is a rather uniform requirement in the various colleges of algebra through quadratics and plane geometry. Many western colleges require plane and solid geometry, receiving students upon certificate, and demanding a less intensive course in plane geometry but a broader course in the entire elementary field. Technological courses usually require solid geometry for entrance, and often plane trigonometry as well. All colleges give advance credit for higher algebra, solid geometry, and trigonometry, in case these subjects are not required for entrance but are offered as part of the preparatory work.

The College Entrance Examination Board, founded in 1900, a voluntary organization of representatives from various colleges and universities, at present sets examinations in the following subjects: (a) Elementary algebra: (i) algebra to quadratics, and (ii) quadratics and beyond. This is divided into two examinations, the first including roots and the theory of exponents, and the second covering quadratic equations,

the binomial theorem for positive integral exponents, and formulas for the n th term and the sum of arithmetical and geometric progressions. (b) Advanced algebra. This includes permutations and combinations; complex numbers with graphic representation of sums and differences; determinants, chiefly of orders not exceeding four; numerical equations of higher degree, Descartes's rule of signs, and Horner's method of solution. (c) Plane geometry. The limitations are not definitely fixed by the board, the statement being: "The usual theorems and constructions of good textbooks, including the general properties of plane rectilinear figures; the circle and the measurement of angles; similar polygons; areas; regular polygons and the measurement of the circle. The solution of numerous original exercises, including loci problems. Applications to the mensuration of lines and plane surfaces." This practically means the plane geometry of Euclid, with an algebraic treatment of ratio and proportion, without the incommensurable cases, and with a large number of exercises. (d) Solid geometry. This requirement is also left indefinite, but it covers the ground of solid geometry as given by Legendre, upon whose work most of our American textbooks are based. (e) Trigonometry. The requirements are as follows: Definitions and relations of the six trigonometric functions as ratios; circular measurement of angles; proofs of principal formulas, in particular for the sine, cosine, and tangent of the sum and the difference of two angles, of the double angle and the half angle, the product expressions for the sum or the difference of two sines or of two cosines, etc.; the transformation of trigonometric expressions by means of these formulas; solution of trigonometric equations of a simple character; theory and use of logarithms (without the introduction of work involving infinite series); the solution of right and oblique triangles and practical applications, including the solution of right spherical triangles.

It is hardly probable that, with the present school system, the entrance requirements can be materially advanced. They may be changed to cover a broader field less thoroughly, but the time does not permit of any more extended treatment of mathematics save as an elective. It is coming to be felt that two years devoted to mathematics in the high school is all that can be demanded, and in this time it is not probable that more can be attempted than algebra through quadratics and plane geometry.

SPECIAL VISUAL AIDS TO TEACHING MATHEMATICS. — There developed in the early years of the twentieth century a great deal of interest in the question of the rôle of intuition, experiment, and visualization in mathematics. The lead was taken quite as much by Austria as by any other single country, with Germany about equally prominent, and with certain parts of Switzerland well to the front. The movement centered largely, in the early school years, in mensuration. It has been found that children of the fifth grade appreciate field measurements involving such simple apparatus as an angle measure (even a radius on a paper protractor), and that they draw figures to scale and compute heights and distances from the drawing. Even before this grade visual aids are used in the teaching of counting, fractions, and the simple mensuration of rectangles; but from this time on it is possible to introduce systematically and successfully aids of a more scientific character. Among those that appeal to children in the elementary school may be mentioned the following: the mirror, for measuring heights; the mirror angle for running perpendiculars, useful in computing distances; the prism, used for the same purpose; the hypsometer, a simple instrument that can be made from heavy pasteboard and used for measuring heights; the clinometer, easily made from a paper protractor, and used in measuring slopes; the pocket compass, or some elaboration of it that permits of measuring horizontal angles; the pro-

tractor with a moving radius, easily made from paper ; graduated staffs, used in measuring altitudes by means of simple ratios, and similar aids that can be used in visualizing mathematics in the field or schoolroom. In the mensuration of solids it is possible to purchase sets of models, the German ones being superior in workmanship to any others. German makers also have for sale models of the solids used in geometry, from the elementary to the most advanced.

In general it may be said that there is quite as much danger in the too extensive use of models and instruments as in their neglect altogether. In the elementary school they add to the interest by their novelty, and to the powers of visualizing similar forms. In the secondary school they are capable of abuse by being used so extensively that the pupil depends upon them too much and fails to acquire the power of mentally seeing the solids that he is studying. A moderate use of simple instruments (homemade, if necessary) for the purpose of mensuration is of unquestionable value. Similarly, the making of certain models in solid geometry is of value, and their moderate use is justified, but to have a model, or even a picture of one, for every proposition makes for weakness rather than strength. The general principle, in elementary as well as higher mathematics, is to use visual aids only so long as they are necessary to fix a mental picture, thereafter referring to them only when this picture becomes so dimmed as to make them again necessary.

TOPICS FOR FURTHER STUDY

1. What are three of the leading reasons for the study of algebra, and what improvement in the teaching of the subject will bring out these reasons more clearly?
2. What are three of the leading reasons for the study of geometry, and what improvement in the teaching of the subject will bring out these reasons more clearly?
3. In the teaching of geometry, what changes have been suggested that do not seem warranted by the experience of the world or by the philosophy of education?

4. Name three of the various types of textbooks in geometry, and discuss the merits of each.

5. What is meant by propædeutic work in mathematics, what should be the nature of this work, and when may it properly be undertaken?

6. What are the claims of practical mathematics, and how can these claims be met without making the subject too technical for the general student?

7. There has been some effort to fuse all mathematics in one subject, not teaching algebra by itself, geometry by itself, and so on. The experience of the world favors teaching these subjects separately, but relating them whenever there are natural points of contact. State the arguments for and against each plan.

8. There is a strong movement in Europe at the present time to make more of the function concept, beginning even in the early stages of mathematics. What is the reason for this movement?

9. In certain communities much is being done at present to systematize the use of intuition in elementary mathematics. What does this mean, and how is the work being carried out?

10. With the new demand of woman for the same opportunities that man enjoys has come a demand for a serious study of mathematics. This is being best worked out in Germany just at present, but the demand must be met in America. What, in your opinion, should be the opportunities offered the girl in secondary mathematics, and how, if at all, should the work be changed to meet her peculiar needs?

11. Is the calculus suited to the high school pupil in America? If so, where should it be taught, for what purpose should it be taught, and what should be its general nature and applications?

12. What movements have taken place intended to make secondary mathematics more interesting to the pupils, through recreations, mathematics clubs, the æsthetics of the subject, or through other agencies? What steps would you advise in this matter?

REFERENCES

BRANFORD, B. *A Study of Mathematical Education*. Oxford, 1908.

CARUS, P. *Foundations of Mathematics*. Chicago, 1908.

HILBERT, D. *Foundations of Geometry*. Chicago, 1902.

RUSSELL, B. *Foundations of Geometry*. Cambridge, 1906.

SMITH, D. E. *Teaching of Geometry*. Boston, 1911.

Teaching of Elementary Mathematics. New York, 1900.

YOUNG, J. W. A. *The Teaching of Mathematics*. New York, 1907.

The files of *L'Enseignement Mathématique*, of Schotten's *Zeitschrift für mathematischen und naturwissenschaftlichen Unterricht*, and of other current educational journals of approximately equal rank.

CHAPTER XIV

THE SOCIAL SCIENCES

HISTORY

NATURE OF HISTORY. — History is concerned with the past life of man considered as a member of society. It is thus distinguished from biography, which deals only with individuals, and from anthropology, which treats of man as a unit in the animal kingdom; but these distinctions are not absolute, for the history of the individual cannot be cut off from the society in which he lives, and no sharp line can be drawn between the natural history of man and his social history. In a looser sense history is often used to denote any succession of facts, as when we speak of the life history of a plant or animal or the history of the solar system — an extension of the term which arises from the general adoption of the historical habit of thought, which looks upon all things in the universe, not as fixed and stable, but as undergoing a process of change. History comprises the whole period of the development of human society from the earliest ages for which evidence has been preserved, and includes the various manifestations of the human spirit in art, literature, and religion, as well as the vicissitudes of states and their leaders and the course of economic and social evolution. Certain of these fields are commonly marked off for separate treatment, so that we have the history of language, of literature, of art, of religion, of philosophy, as well as the social and political sciences which derive their material largely from historical records; but such a division is one of convenience only. None of these more special topics can be understood apart

from the general course of historical development, and only the historian can bring them into their proper relations as parts of the evolution of civilization. Before this broader conception of history the attempt to limit it to "past politics" is rapidly losing ground, but the life of the state, as the most important social group of civilized man, must remain prominently in the foreground of history, by reason of its intrinsic significance and because on the whole it furnishes the most natural category for the classification of historical facts. History thus stands in especially close relations with political science and economics, not only because it furnishes them with the greater part of their materials, but also because it constantly needs their assistance in interpreting the social and political life of the past; and for similar reasons it welcomes the advance of any new sciences, such as comparative and social psychology, which promise to throw further light upon the social life of man.

MATERIALS OF HISTORY. — Unlike the natural sciences, history cannot avail itself of experiment or of repeated observation. Except for the infinitely small body of information which has been acquired by his immediate personal experience, the historian depends entirely upon indirect sources of knowledge, arriving at the facts of the past only by working back from the existing traces which they have left behind them. These traces, the fountainhead of historical knowledge, are called sources. Originally limited to the oral traditions handed down in song and story, and then including written material in the bare lists of early inscriptions and annals, the conception of what constitutes an historical source has widened with the growth of knowledge and with the enlargement of our ideas of the scope of history until it now includes, not only chronicles and public documents, but newspapers and private correspondence, buildings and pictures, ideas, customs, and superstitions, clothing and tools and implements and every sort of object from which information

respecting the human past may be derived. For purposes of convenience, sources are often classified into narrative, such as biographies, chronicles, and memoirs; documentary, including laws, charters, and official acts of every sort; literary, so far as literature throws light on the ideas and conditions of an age; and archæological, including the great body of monuments, works of art, and material remains. The use of these materials for historical purposes often demands technical knowledge of a very special sort, and a group of subjects has grown up which are often called the "auxiliary sciences" of history. Chief among these are language, as a means to the understanding of historical records; palæography, or the science of ancient writings; diplomatics, treating of official documents; epigraphy, or the science of inscriptions; numismatics, archæology, chronology, and historical geography.

PROBLEMS OF TEACHING HISTORY. — The teaching of history, at least in the higher grades of instruction, is concerned with a body of knowledge, a point of view, and a method of inquiry. The body of historical knowledge is enormous and is constantly enlarged by the progress of historical investigation as well as by the lapse of time; and the problem of the teacher is, in the first instance, to select those facts which will make clear the general course of historical development and contribute to an understanding of the periods and countries of special significance with reference to the world as a whole, and to the particular country and age in which the student lives. These facts must on the one hand be seen as actual realities, against their contemporary background, while on the other hand they must be grasped, not as disconnected events or dates, but as bound together in certain relations and forming part of a continuous process of development. The student must learn that while the past is vitally connected with the present and can only be reconstructed by working back from the phenomena of actual experience, it was never the same as the present; and he must

be taught to lay aside for the moment the ideas and standards of his own age in order to enter into those of the age he is studying. Impartiality, sympathy, and imagination thus become necessary qualifications for the study and teaching of history, and the attitude toward the past which is thus attained is often called "historical-mindedness." One element in this is the critical spirit, and the general student of history finds it necessary to know something of the way the historian collects and tests his materials, while the special student requires initiation into the nature of historical evidence and the processes of historical criticism and construction. Such training is necessary, not only for the professed historian, but also for those who as investigators of topics in economics, political science, education, and the history of literature, art, or philosophy, are, often without realizing it, obliged to make use of the historical method of inquiry. In the earlier stages of historical instruction, attention is given particularly to the teaching of a few simple facts and the development of the historical imagination; in the higher stages the number of facts increases, and more emphasis is put upon their relations and political and social significance, and upon the acquisition of a critical and impartial habit of mind; while in the most advanced grades of instruction the student learns to find, test, and combine his facts for himself until he is able to undertake independent research.

THE CHOICE OF MATERIALS. ORGANIZATION OF THE COURSE OF STUDY.—The teaching of history in the secondary school presents two main problems: first, the relative amount of time which should be assigned to the subject, with the periods or kinds of history to which this time should be given; second, the methods of instruction. Each of these problems must be examined separately for the secondary and for the elementary school. History is a record of human experience, the rich variety of which is not indiscriminately valuable for children of all ages. The effort to

find answers to these questions of matter and method appears late in the development of educational systems. This is due mainly to the fact that not until the nineteenth century was the study of history well organized in the colleges.

Growth of History in College and School Curricula. — History received its first recognition as a requirement for entrance to college in 1847. In that year Harvard prescribed Worcester's *Elements of Ancient History*, and the University of Michigan prescribed "Keightley's (or Pinnock's Goldsmith's) *Grecian History to the time of Alexander the Great, and Roman to the time of the Empire.*" For some years the requirement was associated somewhat closely with the older requirement in geography. Both at Harvard and at Michigan examinations in the two subjects were given by the department of history, and the questions set bear evidence of an intention to keep the two fields of knowledge related. American history to the end of the Revolution was added by Michigan in 1870, and the classical requirements at Harvard were, during the next decade, occasionally increased by chapters from Freeman's *General Sketch of European History*. Cornell, founded in 1868, introduced at the beginning a requirement of Greek and Roman history. After 1870, the history requirement gained steadily in favor, especially with the newer and smaller colleges. In 1895, out of a total of 475 universities and colleges investigated by the Bureau of Education, 306 required American history; 127, general history; 112, Greek history; 116, Roman history; 57, English history; 9, state and local history; and 1, French and German history. (*Rep. Com. Ed.*, 1896-1897, p. 468.) The knowledge expected must, however, often have been the merest outline; for, as late as 1890, some of these institutions were still using in their own classes textbooks like Swinton's *Outlines*, Anderson's *General History*, and Barnes's *United States*. The diversity of subject matter required was probably greater than in any other branch of instruction.

Report of the Committee of Ten. — The first important step in the reform of these conditions was taken by the Madison Conference of 1892. The conference did not feel called upon to frame a definite system of entrance requirements, but its brief discussion of the problem and its recommendations for the general improvement of history teaching in the schools suggested, directly or indirectly, the essential features of the system afterward adopted. The next important step was taken in February, 1895, in the appointment, by the New England Association of Colleges and Preparatory Schools, of a committee of school and college teachers of history to deal with the special question of entrance requirements in history. The report of this committee, adopted by the Association in October, 1895, proposed a list of seven topics, each representing one year's work of three periods a week, and requested the colleges to accept any two of these topics as a required subject for entrance. The colleges were further requested to accept "any additional topic or topics from the list as additional preparation for entrance or for advanced standing," and to recognize as "a considerable part of the evidence of proficiency required" certain specified kinds of written work done in the secondary school. The report suggested that entrance examinations in history should be so framed as to require on the part of the candidate comparison and judgment rather than mere memory, and that they should include tests of geographical knowledge. The use of good textbooks, collateral reading, and practice in written work were to be presupposed. The seven topics were: (1) The history of Greece, with especial reference to Greek life, literature, and art. (2) The history of Rome; the Republic and Empire, and Teutonic outgrowths to 800 A.D. (3) German history. (4) French history. [(3) and (4) to be so taught as to elucidate the general movement of medieval and modern European history.] (5) English history, with especial reference to social and political development. (6) American

history, with the elements of civil government. (7) A detailed study of a limited period, pursued in an intensive manner. Three of these topics were in the course of study for secondary schools recommended by the Madison Conference. The other features are directly suggested in the conference report (*Publication* No. 5, New England History Teachers' Association, p. 13).

These recommendations were indorsed, a few months later, by the Schoolmasters' Association of New York and Vicinity. The latter had, however, already proposed a conference on the whole question of entrance requirements, and such a conference had, on the invitation of Columbia, been arranged. It was attended by representatives from Harvard, Yale, Columbia, Cornell, Princeton, and Pennsylvania, and made its report on the first of February, 1896. The recommendations of the New England Association relating to written work and to examinations were adopted, practically without change. The principle of a choice of topics was also adopted, but the details were considerably modified. As additional preparation for entrance, or for advanced standing, the Columbia Conference proposed a second group of topics, each representing two years' work of three periods a week: (1) A course of Greek and Roman history for those only who have offered English history and American history as an elementary subject. (2) A course in English history and American history for those who have offered Greek and Roman history as an elementary subject. (3) A course in the history of Europe from the Germanic invasions to the beginning of the seventeenth century. (4) A year's study of any of the elementary fields not already offered as an elementary subject, combined with a year's study of a limited period within that field. (*Publication* No. 5, New England History Teachers' Association, pp. 16, 17.)

The Committee of Seven.— In the meantime, the Committee on College Entrance Requirements appointed by the

National Education Association in July, 1895, had been seeking the coöperation of organizations interested in the problem from the point of view of the special subjects. The response of the American Historical Association was the appointment of the Committee of Seven, whose report, made in 1899, remains the standard document on the whole question of history in American secondary schools. In framing recommendations on college entrance requirements the Committee of Seven recognized two things as essential: (1) "that the fundamental scope and purpose of the major part of the secondary schools be regarded"; and (2) "that elasticity be allowed that schools may fit pupils for college and yet adapt themselves to some extent to local environment and local needs." (*Report*, 121.) A "unit" of history was defined as "either one year of historical work wherein the study is given five times per week, or two years of historical work wherein the study is given three times per week." The recommendations may be summarized as follows: (1) Institutions with a "system of complete options in college entrance requirements" (*e.g.* Leland Stanford) were asked to accept 4 units in history "as an equivalent for a like amount of work in other subjects." (2) Institutions that prescribed certain studies and, in addition, required others from an optional list (*e.g.* Harvard) were asked to place 1 unit of history on the prescribed list, and 1, 2, or 3 units on the optional list. (3) Institutions with prescribed requirements only, *i.e.* "without options" (*e.g.* Yale), were asked to require at least 1 unit of history. (4) Institutions with several distinct college courses requiring different groups of preparatory studies for entrance (*e.g.* Michigan) were asked to require 1 unit of history for the classical course; 1 unit for the Latin course; 2 units for the scientific course; and 3 units for the English course. (*Report*, 123-129.) The Committee of the National Education Association accepted these recommendations, but with the proviso that one year of American

history and government should be accepted as a requirement for admission by all colleges and universities. In a similar spirit the recommendation for a year of intensive study was qualified by the phrase, "especially of the United States." (*Proc., N. E. A.*, 1899, pp. 648, 665.) At the present time, the units most widely recognized are the "blocks" or periods proposed by the Committee of Seven for a four-year course in secondary schools: (1) ancient history; (2) medieval and modern European history; (3) English history; (4) American history and civil government. These are the subjects listed by the College Entrance Examination Board. The question of entrance requirements continues to agitate teachers of history. It is admitted that the action of colleges in recent years in increasing the amount of history that may be offered for entrance has tended to increase the amount of history taught in secondary schools, but its influence on methods of teaching remains questionable. Teachers still complain, as they complained in the days of the Madison Conference, that the present examinations compel the use of "bad methods for college preparation," and they are still urging, as the Madison Conference urged, "a change by which schools which use proper methods shall have some advantage."

Recent Modifications. — The complete success of the movement for uniformity has been hindered by the consequences of the elective system introduced into the schools. Sometimes also the fact that many colleges have not given credit for more than one or two units of history has had a similar retarding influence. An investigation made in 1909, principally of schools in the Middle West, showed, however, that out of eighty-three schools offering a three-year course fifty-six required all three units for graduation.

Dissent from the recommendations of the Committee of Seven has usually been prompted by the desire to lay greater emphasis upon the modern period. In order to satisfy this desire a Committee of Five, partly of the same personnel,

also appointed by the American Historical Association, advised that schools ready to make a change should place English history as far as 1760, with its European connections, in the second year and give the third year to a course on the last century and a half of European history.

Modification of Course in New Types of Schools. — The recent development of commercial and technical high schools has rendered necessary a course adapted to their requirements. For them emphasis should be put upon the history of the arts and of trade. The interests of the two are also distinct, because, although the achievements of the Greeks and the Romans, and, in a measure, of medieval peoples, are instructive to students of certain technical arts, students of commerce will find the modern period the most important. Both should be taught to place the special aspects of life which they study in a true historical setting, while at the same time they should not forget other phases of history which explain the general growth of civilization.

European Courses of Study and Programs. — In France and Germany the secondary school, *lycée* or *gymnasium*, gives instruction in history throughout a nine-year course. The course corresponds to a possible course in our schools running from the fifth grade through the elementary school, the secondary school, and up to the third college year. History is also given in elementary schools distinct from the *lycée* and the *gymnasium*, and is parallel, therefore, to the first part of the secondary school course. In the elementary school the content is confined more exclusively to the national history and omits ancient history. The last seven years of the secondary course are divided into two cycles, one of four and one of three years, thus including two journeys through the field from ancient times to the present day. In the second cycle of the French course, if the pupil is on the classical side, *i.e.* has Latin and Greek, or Latin and the "living" languages, he devotes four hours to history, two to ancient and two to

modern; if he takes the sciences with either Latin or the living languages, he devotes two hours to modern history. Except at this period of the course, the time given to history, both in German and French schools, averages three hours a week, and the work is closely correlated with geography.

In England the average amount of time given to the subject is two hours a week both in the preparatory years and in the secondary school proper. On account of the variety of type in the organization of the English schools it is difficult to summarize the practice. The most authoritative recommendation is presented in *Circular 599*, published by the Board of Education in 1908, and includes, for the first stage, with children up to the age of twelve, stories from the history of England and of other countries, centering about great characters like Charlemagne, Columbus, and Washington, as well as famous Englishmen; for the ages between twelve and sixteen, a chronologically continuous course in English history with the European connections; during the final years, classical history for students going to the universities, English or modern continental history for others. The circular records a gradual falling off in the practice of introducing a special period for more intensive study, and argues that there should be judicious selection all the way through of incidents and characters for special emphasis. The circular also criticizes the concentric method by which in some schools the whole subject of English history is gone over each year summarily. In too many instances history is lumped in the program with "English subjects." The general influence of the type of questions asked in various public examinations, in competition for prizes, honors, etc., has been to retard the development of a plan of study satisfactory to the more progressive teachers.

From the practice abroad, as well as from the character of the efforts to promote the teaching of history in American schools, it is evident that the best opinion is in agreement

upon the necessity of making the instruction continuous throughout the pupil's school career. Only by this means is it possible to form in his mind a useful framework of historical events and to train him to think of events historically. Time is also needed for the growth of interest and the formation of a habit of reading historical books. In the opinion of a recent French minister of public instruction the habit of reading historical books is an important element of the reading habit, which, next to the habit of observation, should be the aim of popular education, and without which the pupils are in danger of falling into illiteracy after they leave school.

METHODS OF TEACHING.—Upon methods of teaching there is less agreement than upon questions of program, although for the attainment of the aims of the subject an effective method is more important than the choice of any particular period for study. If the method of teaching is not effective, the subject is discredited as an instrument of education. As the matter now stands, the statement that a pupil has had a course in ancient or medieval and modern history means much, little, or worse than nothing. The most urgent need of the present time is the adoption and the general practice of a well-considered method of teaching the subject. In the management of subjects which are already well organized pedagogically, like English, chemistry, or Latin, teachers know what is expected the first month, the first term, the first year; they realize what are regarded as the essential elements of a good method. But the teacher of history may confine his work wholly to the explanation of the paragraphs of the textbook, or he may assign selections for reading in other books, or he may also utilize collections of source material. He may train his pupils in the use of notebooks or he may never allude to them. What he shall decide to do seems to depend generally upon his individual preference. The well-trained teacher is capable of solving the problem for himself, but many others are groping about among

haphazard experiments or apathetically following methods sanctioned by local tradition.

In Germany there is a recognized method of teaching history. This is true of France also, although French teachers differ among themselves in regard to the function of the textbook. In Germany reliance is placed mainly on the teacher and the instruction is principally oral. Many teachers even object to the use of a notebook during a class exercise, because they wish the attention of the pupils concentrated upon what they are saying. By a process of questioning and repetition they work the facts literally into the pupil's mind, so that he is gradually enabled to construct so solid a framework of the past that it is serviceable for all his future work whether in the university or elsewhere. Books of simple outlines, or *Leitfaden*, are used to supplement the oral work. So complete is the dependence upon the teacher that few or no references are given to historical works and there is slight use of selected sources. This has been criticized as not offering the pupil enough training for independent work in history and as being in one respect a poor preparation for the freedom of university work. Such reliance upon the teacher is possible only because of the thorough training insisted upon by the state in the case of every teacher. In both France and Germany the subject is intrusted almost wholly to special teachers. Although the French use the textbook more than the Germans, they generally go over the lesson in a carefully prepared lecture which the pupils record in notebooks. The reason for this, when a textbook is also used, is the need of placing the right emphasis and of stimulating the attention. It is believed that by such a method the dull pupil obtains more than if he is expected to master without direction the topics assigned. The French do not make extensive use of selected sources or of other reading references. In England, with no central controlling authority, the methods of work show less uniformity than those of France or Germany, but where the subject is well taught it

is likely to include excellent training in writing up topics on the basis of an intelligent use of reading references.

European methods of teaching history should not be transferred mechanically to American practice, but acquaintance with them emphasizes the value of a standard of work and directs attention to the elements of the problem. What may be suited admirably to the needs of the German boy in the *gymnasium* or the French boy in the *lycée* may not take sufficient account of the more precocious individuality of the American boy. An adequate method must be the outcome of a careful study of the child and a wise consideration of the benefits which he should derive from his work in history. The study of history should not merely give him a body of information, it should affect his attitude towards the world and train his mind for the successful search for certain kinds of truth.

In the higher grades of the elementary school or the early years of the extended high school course the pupil should be enabled to form a picture, fairly accurate in its details, and in chronological order, of the principal events of American history and of its European background, in order that it may be a serviceable framework for later historical knowledge. More emphasis should be laid upon reading, in books furnished by the school library or by local public libraries. Some use can also be made of original sources, with the aim of illustrating facts easily within the comprehension of children of this age. Selections which illustrate two sides of a controversy, like that between Parliament and the colonies after 1765, or between the North and the South before the Civil War, will train pupils who are beginning to read the newspapers to read more intelligently and with some effort of judgment. There should be practice in making simple maps, explaining geographically an historical situation. Outline maps may be used for this work. Pictures offer an opportunity not only for awakening interest, but also for giving training in observation.

The problem of method for the secondary school is more complex, because the element of training should receive greater emphasis. The most obvious requirement of a course is the mastery of the contents of the textbook. To attain this result there are needed, besides the ordinary recitation exercises, the preparation of outlines and summaries, the construction of what the English call "date strips," and the preparation of reviews. The teachers most interested in the improvement of the teaching of history would add some reading from historical books other than the textbook, the study of selected sources of a simple and clearly illustrative character, and the making of reports upon topics with the use of several books of reference. There must also be the construction of maps. How many of these exercises the individual teacher may be able to embody in any particular course depends upon the special conditions of the school, that is, the amount of other work demanded of the teacher, the existence of a school or public library, the number of available historical maps, etc. Each exercise should be repeated at least once, because the first attempt serves principally to make clear the difficulties. There should be orderly progress in the manner of work from the beginning to the end of the course. The pupil is studying history in order to learn how to study history as well as to acquire a body of historical facts. Each exercise should have relation to the preceding and to what is to follow.

The teacher's first task should be to construct a calendar of the course, apportioning the work of each day, and indicating at what stage any particular exercise is to be attempted. An examination of the textbook will show what topics are adequately treated and upon what topics there must be supplementary oral explanations or informal lectures. It is apparent that an exercise in constructing summaries should be inserted after an epoch of marked characteristics has been studied. Upon the completion of the study of a long and complex process an outline, chronological or topical, will be useful.

Teachers may wish to use a simple outline for each day's work, but the construction of such outlines should not be required of all the class every day, for this work would soon become mechanical and wearisome. A review of the geographical relations of the subject will show at what points illustrative maps should be constructed. Certain topics should be studied partly through the medium of pictures. If there are to be reports on long readings, the place of these will be determined by the interest of the topic or incident and the availability of books on the subject. The same is true of topical studies, of which there should not be more than two or three during the particular course. The results of these exercises should be embodied in the pupil's notebook. They should be written on sheets of paper which may be inserted without copying in a loose-leaf notebook. The pupil will need careful instruction upon the manner of preparing this written material for the notebook.

The teacher may not be able to insert upon the calendar more than an indispensable minimum of exercises, because such exercises require efficient supervision, and the burden upon the average teacher is already heavy. The way to meet the difficulties of the situation is to agree upon what this indispensable minimum includes and from it as a basis work steadily toward the desirable.

VISUAL AIDS TO TEACHING HISTORY.—An excellent description of special aids to the visualization of history, embracing the United States and the principal countries of Europe, was published in the *History Teacher's Magazine* of February, 1910, and can now be obtained in pamphlet form from the McKinley Publishing Co., Philadelphia, for ten cents. There is also available a classified catalogue of similar scope prepared by a committee of the New England History Teachers' Association, and published by Houghton Mifflin Co., at fifty cents. Both of these contain price lists and names of makers, publishers, and dealers. The extensive German material is more

fully listed, with prices but without names of makers or publishers in the *Verzeichnis der bewährtesten Lehr- und Anschauungsmittel für Höhere-, Mittlere- und Elementarschulen* issued from time to time in Leipzig by K. F. Koehler. Copies of this can usually be purchased for fifty cents. It should be noted, however, that Koehler accepts orders for material only when sent through regular dealers. Special circulars descriptive of the remarkable Rausch models are sent gratis on application to Friedrich Rausch, Nordhausen a. Harz, Germany. The aids of special practical interest to American teachers of history, and the question of how to use them, form the subject of several chapters in Johnson's *Teaching of History in Elementary and Secondary Schools*.

CIVICS

THE TERM CIVICS.—The term "civics" is now generally employed to refer to the teaching of civil government in our elementary and secondary schools and in colleges. The term "civil government," which was formerly very commonly used for describing this study, has been abandoned, because in its interpretation it was usually narrowed down to a study of the mere framework of government. The word "civics" is said to have been introduced by Henry Randall Waite (see *Standard Dictionary*), and has the advantage over the term "civil government" in that it is now generally understood to include: (1) ethics, or the doctrine of duties in society; (2) civil polity, or governmental methods and machinery; (3) history of civic development and movement.

Like most subjects outside of the three R's in the elementary school curriculum, and the classics and mathematics in the secondary school course of study, the subject matter of civics was not taught in schools until some years after the middle of the nineteenth century.

INTRODUCTION INTO THE SCHOOLS.—The study made but slow progress in the schools, though the need of it

was urgently felt because of the ever increasing immigration of foreigners to American shores. As most of the colleges gave little or no instruction in political science, they took no steps toward making it an entrance requirement. After 1870 the subject began to find its way gradually into the elementary schools.

In 1895 appeared the *Report of the Committee of Fifteen* of the National Education Association on the subject of Elementary Education. This committee recommended in connection with the subject of United States history that there should be given a study of the outlines of the Constitution for 10 to 15 weeks in the last year of the elementary school. In 1897 the Committee on Rural Schools of the same Association made a report recommending a course in United States history and civil government for normal school teachers who were to teach in the rural schools, and made some suggestions about teaching of morals and civics in such schools. In 1899 the Committee of Seven of the American Historical Association — a committee appointed at the instance of a Committee on College Entrance Requirements of the National Education Association — made an elaborate report on history in the schools. They recommended that the fourth year of the high school course be devoted to American history and civics, and that the two subjects be taught in separate courses where it was possible to get the time. Where this was not possible, the committee advised teaching them together.

The high schools generally pursued the latter method in order to save time, with the result that the civics work was mainly in the nature of constitutional history. Very little attention was given to the other elements of civics: the duties of citizenship and government in its actual workings. Because of the failure of the colleges to require a knowledge of civics for entrance, very many schools neglected the subject almost wholly. In 1904 the New England History Teachers' Association published a syllabus upon the lines laid down by

the Committee of Seven, and made the same recommendations in regard to civics. This tendency to treat civics as the "poor relation" of United States history and to make its treatment only one of constitutional development met with strong opposition in the Association of History Teachers of the Middle States and Maryland, in the North Central History Teachers' Association, in the New England History Teachers' Association, and in the associations of teachers of various states. Vigorous protests were made against considering the history of an institution the same as the study of an institution in its actual working to-day.

The results of the agitation of the opponents of a combination course resulted in the appointment of a Committee on Civics of the New England History Teachers' Association, and of another by the American Political Science Association. The preliminary sheets of a syllabus were published by the first association in 1908, and the second association published a report in the same year calling for a separate course in civics in the last year of the high school and recommending the making of the subject a college entrance requirement. Throughout the report there is a strong insistence on that view of civics which makes it a study of government in its actual working — national, state, and municipal. The National Municipal League has been actively engaged in promoting the study of municipal civics in the schools, and in its proceedings of 1905 it presented a syllabus for such instruction in both elementary and secondary schools. So far the recommendations have had little effect. The schools of Cleveland, Ohio, have had an admirable syllabus drawn up for use in this subject, and the High School of Commerce in New York City has established a course in Municipal Activities.

PRESENT STATUS. — Notwithstanding the great activity of civic bodies and teachers' associations in all parts of the country, civics as a subject in the schools is still in a very unsatisfactory condition. In spite of the emphatic statements

of various committees, it is still taught in the form of constitutional history, and the pupil gets little notion of the way in which the government is actually being carried on at the present time. In the elementary schools of Boston and vicinity no attention is paid to it until the last year, though vague statements are made at times that "civil government shall be taught throughout the course in history." In the last year provision is usually made for the study of the Constitution. In New York City in the elementary schools the syllabus calls for lessons in civics beginning with the fourth grade, and these run through the fifth, sixth, seventh, and eighth grades. In the absence of a detailed syllabus the work is not as well carried out in some schools as it is in others. The city of Cleveland has prepared the best syllabus for civics in the elementary schools. It begins in a very simple way in the third grade, and is carried through the balance of the eight grades. In the Latin schools of Boston and vicinity the subject is virtually non-existent. In the high schools it is optional in the third year, and sometimes required, as in Cambridge. When optional it is seldom taken. In New York City and vicinity the course in civics is a part of the course in American history, and is required for graduation.

Between the two extremes represented by these localities there are varying conditions, but in the large majority of the schools where the subject is taught at all it is given as an adjunct of history. As far as statistics can be gathered, it may be stated that approximately one fourth of our secondary schools give no training in civics at all, about one half combine it with American history, and about one fourth give a separate course in it.

At the present time a Committee of Five of the American Historical Association is working on a revision of some of the recommendations of the Committee of Seven, and has made a preliminary report in which a separate course and a separate examination in civics in the fourth year of the high school

course is recommended as required. In New York State various committees and civic bodies are at work on the subject, and the same is true in many other states. From such activity it is probable that much more substantial courses in civics will be offered in elementary schools and high schools within the next decade than have ever been offered before.

METHODS OF TEACHING. — The earliest advocates of the teaching of civics in the schools had in mind a method of instruction which should give to pupils a knowledge of the framework of government as it was outlined in the Constitution of the United States. This was the idea of Daniel Read and of the National Teachers' Association. From the resolutions passed by that body in 1869 it is evident that it thought that instruction in civics consisted in teaching "the principles, the structure, and the history of our Political Institutions." Moreover, the study was to be taken up in connection with United States history, and for this purpose the Constitution of the United States was appended to the grammar and high school histories published in the seventies and early eighties. In the body of the texts almost nothing was given concerning constitutional government or the working of the local, state, or national institutions. About two thirds of each text was taken up with the colonial period, and the emphasis throughout was laid on picturesque narration.

For civic instruction the method consisted in giving the pupils the Constitution to read or to commit to memory. No illuminating material on the actual working of our institutions, national, state, and local, such as could have been found in De Tocqueville, was presented, — a fact no doubt due to the absolute inability of the teachers. This mere "cramming" on the Constitution was felt to be unsatisfactory, and though the study of government was still largely conducted by such a method and felt to be indissolubly connected with the study of United States history, small texts were published in the seventies containing the clauses of the Constitution with

comments on them. Such texts were not generally put in the hands of the pupils, but were of aid to the teacher. This method of study of the dry bones of our institutions continued until the middle eighties, when Jesse Macy of the University of Iowa published his small text entitled *Our Government*. This was an attempt by a competent writer to change the prevailing method of instruction in government, and to put interest and life into the mere framework by showing the actual workings. Attention was not confined to the national government, as had been the almost general custom in the past, but considerable time was given to the consideration of local and state governments. In 1888, with the appearance of Bryce's *American Commonwealth*, the revolutionizing of the methods of instruction was made possible. With this monumental work on our government in its actual workings before them, the writers of school texts began gradually to change their methods of treatment. Slowly and almost imperceptibly the texts on civics began to treat of actual government. The committing to memory of the Constitution and the dry commentary on its clauses began to give way to a study of government as actually carried on.

Such a change in method, however, was not by any means general. In most of the schools, grammar as well as high, the average instruction given was usually nothing more than a mere "cramming" on the Constitution. Texts still continued to be written which were nothing except dry commentaries on the clauses of the Constitution, and the texts determined the methods of instruction. It was only in a few of the most progressive schools that good instruction in civics was given.

Meanwhile a very decided change had taken place in the character of the textbooks on United States history. More and more space was given to the constitutional and institutional aspects, and the idea was thus perpetuated that all necessary instruction in civics could be given through the medium of history — a separate text or course for civics not

being considered necessary. This method of instruction in the grammar schools and high schools was favored because it "saved time" and because of the conditions surrounding college entrance examinations for which the high schools largely prepared. Most of the colleges gave either very indifferent instruction in government themselves, or none at all, and had taken no steps toward demanding a knowledge of civics for entrance. This prevailing method of instruction gave to the pupils scarcely anything more than a knowledge of constitutional history. This was to a certain extent encouraged by the *Report of the Committee of Seven* of the American Historical Association, 1899, for though recommending a separate text and course in civics it left it open for the schools to believe that the study could well be carried on without such.

Objections to this method of instruction were frequently heard from teachers and superintendents, but it was not until the Committee on Civics of the New England History Teachers' Association, 1909, and the Committee of Five of the American Political Science Association, 1909, made their reports that the issue was squarely made that instruction in civics in schools should be on the actual working of our government and that the methods to be employed should be such as to give something more than constitutional history, and should be through the medium of a separate course. The *Report of the Committee of Five* of the American Historical Association on the revision of the *Report of the Committee of Seven*, 1910, seems to agree with the reports of the two committees mentioned above.

Some schools already have in operation distinct courses in civics, though in the larger number of schools throughout the country the older methods of instruction still prevail. In those schools where the separate course is given there are two ways in which it is conducted: (1) in some the course comes after the course in United States history, and (2) in others it is conducted parallel with it. Those who favor the first method

maintain that it is necessary for the pupil to know the history before he is able to understand the government in its actual working at the present time; and those who favor the second say that by the parallel method much time is saved by avoiding unnecessary repetition and that a better opportunity is offered for taking up current topics because of the longer period during which the course is studied.

In the best high schools of to-day a course in civics is given which has devoted to it 5 hours a week for 20 weeks or 3 hours a week for 40 weeks. A substantial text is placed in the hands of the students, and also a fair number of special works on the federal, state, and local government. Not only is the government of the United States studied, but its institutions are compared with those of European governments—the most effective results being derived from comparison. Each student is called upon to present reports both oral and written on topics connected with this comparative study.

In connection with the course a close study of the newspapers and magazines is made for current political happenings, and the students are called upon to give three-minute extemporaneous talks on political events both at home and abroad. The material gathered is put on bulletin boards, pasted in scrapbooks, and used in civic and debating clubs. Government reports, journals, legal forms, and material of an allied nature are consulted in the libraries. Visits are made to the meetings of legislative bodies, courts, and committees. Though the course outlined above is far from being in general use, it is becoming more and more common.

The activities of the National Municipal League have been responsible for the introduction in some city schools of special courses in municipal government. Sometimes this course is placed in the last grade of the grammar school or the first year of the high school. The method of teaching is largely inductive. The pupil is called upon to look about him for answers to certain questions given by the teacher and to come to the

class prepared to report. The pupil in a way is thus the maker of his own textbook. This simple course of instruction is supplemented in the last year of the high school with older pupils by studying the causes for the failures and successes of municipal government at home and abroad.

In the most modern methods of teaching civics, the idea that the subject should be used to teach patriotism and to drag out moral lessons has been abandoned. The aim has been reduced to the purely practical one of developing good citizens, intelligent as to their duties, knowing wherein the government is good or bad, and able by virtue of their intelligence concerning better conditions prevailing elsewhere to try to improve their own institutions.

ECONOMICS

INTRODUCTION INTO THE SCHOOLS.— This subject has been defined as the study of that which pertains to the satisfaction of man's material needs,—the production, preservation, and distribution of wealth. As such it would seem fundamental that the study of economics should find a place in those institutions which prepare children to become citizens,—the elementary and high schools. Some of the truths of economics are so simple that even the youngest of school children may be taught to understand them. As a school study, however, economics up to the present time has made far less headway than civics. Its introduction as a study even in the colleges was so gradual and so retarded that it could scarcely be expected that educators would favor its introduction in the high schools.

Previous to the appearance, in 1894, of the *Report of the Committee of Ten* of the National Education Association on Secondary Education, there had been much discussion on the educational value of the study of economics.

Since then the subject of economics has gradually made its appearance in the curricula of many eastern high schools.

It has been made an elective subject of examination for graduation from high schools by the Regents of New York State, and for admission to college by Harvard University. Its position as an elective study, however, has not led many students to take it except in commercial high schools, because in general it may not be used for admission to the colleges.

Its great educational value, its close touch with the pupils' everyday life, and the possibility of teaching it to pupils of high school age are now generally recognized. A series of articles in the National Education Association's *Proceedings* for 1901, by Spiers, Gunton, Halleck, and Vincent bear witness to this. The October, 1910, meeting of the New England History Teachers' Association was devoted entirely to a discussion of the Teaching of Economics in Secondary Schools, and Professors Taussig and Haynes reiterated views already expressed. Representatives of the recently developed commercial and trade schools expressed themselves in its favor.

Suitable textbooks in the subject for secondary schools have not kept pace with its spread in the schools. Laughlin, Macvane, and Walker published books somewhat simply expressed; but later texts have been too collegiate in character. There is still needed a text written with the secondary school student constantly in mind, and preferably by an author who has been dealing with students of secondary school age. The methods of teaching *mutatis mutandis* have been much the same as those pursued in civics. The mere cramming of the text found in the poorest schools gives way in the best schools to a study and observation of actual conditions in the world of to-day. In the latter schools the teacher has been well trained in the subject, whereas in the former it is given over only too frequently to teachers who know little more about it than that which is in the text.

TOPICS FOR FURTHER STUDY

1. What aspect of history — cultural, political, institutional, etc. — is preferable for high school study?
2. To what extent is the source material method desirable or possible in the high school?
3. What are the purposes of the study of history in the high school?
4. To what extent should the study of history be connected with the study of civics? How can this connection be best made?
5. What relations can or should be established between the study of history of the United States and the study of economic problems?
6. What are the best materials of study for United States history?
7. Can "critical study" of historical problems be developed in the high school?
8. What are the tests or the principles involved in a good history textbook for high school?
9. What are the principles involved in an examination in history? What kind of questions should be asked?
10. What advance was made in the Report of the Committee of Seven upon the Report of the Committee of Ten?
11. What advance upon the Report of the Committee of Seven, by subsequent reports?
12. What advantages are involved in the new classification or delimitation of historic periods?
13. What kind of history should be taught in the new vocational high schools?
14. What are the merits of the course of studies followed in the European secondary schools as compared with those of the American high school?
15. What are the merits of the methods used in European schools as compared with those of the American high school? Of the textbooks?
16. To what extent should visual aids to teaching be used in history?
17. What topics in the subject of economics can be treated in the high school?
18. What methods and materials of study are appropriate for high school work in economics?
19. Outline a course of study in economics for the high school, using local materials and problems as a basis. For civics.
20. How can the study of civics be made to function directly in training for citizenship?
21. What are the advantages and disadvantages of interesting the pupil directly in local political, economic, and civic problems?

REFERENCES

History

- ALLEN, J. W. *The Place of History in Education*. London, 1909.
- ANDREWS, C. M., GAMBRILL, J. M., TALL, LIDA L. *A Bibliography of History for Schools and Libraries*. New York, 1910.
- Association of History Teachers of the Middle States and Maryland. *Annual Minutes*, from 1903.
- BARNES, MARY SHELDON. *Studies in Historical Method*. Boston, 1896.
- BLISS, W. F. *History in the Elementary Schools; Methods, Courses of Study, Bibliographies*. New York, 1911.
- BOURNE, H. E. *The Teaching of History and Civics in the Elementary and Secondary School*. New York, 1910.
- Committee of Eight, *Report of the, to the American Historical Association. The Study of History in the Elementary School*. New York, 1909.
- Committee of Five, *Report of the, to the American Historical Association. The Study of History in Schools*. New York, 1911.
- Committee of Seven, American Historical Association. *The Study of History in Schools*. New York, 1899.
- England Board of Education. *Teaching of History in Secondary Schools*. London, 1908.
- FARRINGTON, F. E. *French Secondary Schools*, Chap. XI. New York, 1910.
- HEARNSHAW, F. J. C. Teaching of History by Means of Local Records. *Educ. Times* (London), Vol. LXV, February, 1912, pp. 59-60. Contains also Report of Annual Meeting of the Historical Association.
- HINSDALE, B. A. *How to Study and Teach History*. New York, 1893.
- Historical Association. *Leaflets*. London, from 1906.
- Indiana University Bulletin. *History Teaching in High School*. Bloomington, 1909.
- JÄGER, O. *The Teaching of History*. Tr. by H. J. Chaytor. London, 1908.
- JOHNSON, H. *History in the Elementary School*. New York, 1908.
- KEATINGE, M. W. *Studies in the Teaching of History*. London, 1910.
- LANGLOIS, C. V. *Manuel de Bibliographie historique*. Paris, 1901-1904.
- and SEIGNOBOS, C. *Introduction to the Study of History*. Tr. by G. G. Berry. New York, 1898.
- MACE, W. H. *Method in History*. New York, 1903.
- McMURRY, C. A. *Special Method in History*. New York, 1903.
- New England History Teachers' Association. *Historical Sources in Schools*. New York, 1902. *Syllabus for Secondary Schools*. Boston, 1904. Various publications since 1897.

- New York State Education Department Bulletins. *Course of Study and Syllabus for the Elementary Schools. Syllabus for Secondary Schools.* Albany, 1910.
- North Central History Teachers' Association, *Proceedings*, from 1899. *Report of a Conference on the Teaching of History in London Elementary Schools.* London, 1911.
- RICE, EMILY J. *Course of Study in History and Literature.* Chicago, 1897.
- RUSSELL, J. E. *German Higher Schools*, Chap. XV. New ed., New York, 1905.
- SALMON, LUCY M. *Some Principles in the Teaching of History.* Chicago, 1902.

Civics

- ANDREWS, C. M., GAMBRILL, J. M., TALL, LIDA L. *A Bibliography of History.* New York, 1910.
- BOURNE, H. E. *The Teaching of History and Civics.* New York, 1902. At the beginning of each chapter this book gives extended bibliographies.
- SCOREL. *N. E. A. Proceedings*, 1899.
- WELLING. *N. E. A. Proceedings*, 1903.
- WYER, J. I. *A Bibliography of the Study and Teaching of History*, compiled in Volume I of the *American Historical Association Proceedings* for 1899, pp. 559-612, particularly on p. 593.

Sample chapters of an Outline for the Study of American Civil Government, published by the New England History Teachers' Association, also have good bibliographies.

The published proceedings of the various associations mentioned in this article contain, in addition to the reports referred to, numerous articles on civics and its place in the curriculum.

The *Atlantic Educational Journal* published during 1908-1909 a bibliography of history for teachers and is going to add to it material for civics.

Economics

- CLOW, F. R. Economics as a School Study, in the *Economic Studies* of the American Economic Association for 1899. An excellent bibliography is given. It may be supplemented by articles or addresses since 1899 which have been mentioned above. New York, 1899.
- COSSA, L. *Introduction to the Study of Political Economy*; tr. by L. Dyer, London, 1893.
- HAYNES, JOHN. Economics in Secondary Schools. *Education*, February, 1897.

CHAPTER XV

FINE ARTS AND MUSIC

ART IN EDUCATION. — A study of education in its earlier forms, not only in savage communities, but in a civilization as advanced as the Athenian, reveals the great rôle played by the arts. Anthropological investigations have confirmed the obvious educational influence by showing the great part played by the arts in the life of the community and in determining progress. Psychology adds to these convictions the fact of the fundamental character of the impulsive tendencies which are the physiological origin of the activities that lead to the arts. All of these facts are opposed to the common assumption that the arts represent a kind of educational luxury and superfluity.

Classification of the Arts. — Various classifications have been made of the arts, — they have been subdivided into the spatial and the temporal, arts of rest and motion, of the eye and the ear, etc. However correct for their own purposes, these divisions are educationally defective in that they start from art products rather than from the psychophysical acts from which these products originate. More significant from the educational point of view is the classification of Santayana according to which arts are distinguished into those that spring from automatisms, *i.e.* organic or “spontaneous” movements which, when rhythmically ordered and accompanied by intensified emotion, themselves constitute acts, and those in which the movements, even if similarly induced originally, terminate in effective enduring modifications of natural objects. The dance, pantomime, song, music, etc.,

belong in the first class; the second class Santayana terms "plastic," including in it architecture, sculpture, painting, and design.

Principles underlying Art in Education. — Anthropological and historical inquiry have fairly established the following principles: first, that art is born of primary impulses of human nature when the activity, whether automatic or plastic, has social value; second, that this social value is conferred by the tendency of the activity or its product to spread an emotional mood favorable to joint or concerted action. Otherwise put, the arts, in their origin, tended to contagion or communication of an emotion, that produced unity of attitude and of outlook and imagination. From this point of view, no sharp line divided the fine and useful arts from each other. Any useful object — a piece of pottery or of weaving, an implement of hunting — that provokes social reminiscences and anticipations attaches contagious emotions to itself, and acquires æsthetic quality. The marked distinction between useful and fine arts is chiefly a product of slave labor or of commercial production, making things for a market, under circumstances where the factor of shared emotional life is eliminated.

Another significant trait of the arts in their simple and more natural form is the prominence of the festal element. Tribal dances are the background out of which music, poetry, and the drama all gradually differentiated. These pantomime dances were either occasional or ceremonial, *i.e.* they were either community celebrations of more or less choice episodes happening to attract general attention, or else were stated and recurrent celebrations of important tribal traditions and customs, attaching to changes in the season, return of food animals, gathering of crops, war expeditions, etc.

Some of the educational bearings of these considerations, psychological and ethnological, come out conspicuously in the older Athenian education. Music (in the Greek sense) and

gymnastic were, in general, and in many of the details of their educational use, very direct outgrowths of the rôle of the dramatic and communal arts of more primitive societies. It is not difficult to detect in Plato's treatment of gymnastics in the *Republic* and the *Laws* the fact that dances, etc., originally associated with industrial and military crises in the life of a people, had become so saturated with elements of rhythm, measure, and order, and with social memories and hopes, as to present great value in the training of the young; while music was frankly a vehicle for carrying what was of typical or idealized value in the traditions of the Greek people, by enhancing their emotional value so that they would deeply, though unconsciously, modify the character of children's tastes and likes and dislikes in the direction that reason would later consciously approve.

If we attempt to summarize the meaning for present educational practice, of the facts mentioned in this brief summary, the following points stand out clearly:

Arts are Essentials in Education. — 1. There has been great loss in relegating the arts to the relatively trivial rôle which they finally assumed in schooling, and there is corresponding promise of gain in the efforts making in the last generation to restore these to a more important position. Viewed both psychologically and socially, the arts represent not luxuries and superfluities but fundamental forces of development.

Expression precedes Appreciation. — 2. Instead of æsthetic appreciation, the sense of beauty, etc., coming first and leading to artistic expression in order to satisfy itself, the order is the reverse. Man instinctively attempts to enhance and perpetuate his images that are charged with emotional value by some kind of objectification through action. The outcome inevitably is marked by certain factors of balance, rhythm, and constructive order, and by the function of representation, *i.e.* of recording in some adequate way the values to which emotions cling. The sense of beauty, or æsthetic appreciation, is a

reflex product of this attempt at production. A product which is objectively crude but which represents a genuine attempt at embodiment of an experienced value of unusual emotional quality, is more likely to be an effective means of cultivating taste and æsthetic sensitiveness than the presentation for passive appreciation of much more perfect works produced by others. The latter are indispensable, but their function is to serve as models which will stimulate to appreciation of crudities and imperfections that may be refined away, and will enlarge the emotional images out of which personal expression springs. In the end, the great majority of pupils are of course to become appreciators of art rather than its producers in any technical sense. But only by taking some part in creative production (and that not for the sake consciously of producing beauty but simply of embodying vital and significant feelings) can a wholesome and natural attitude of appreciation finally be secured.

Social Activities furnish the Starting Point.—3. The social, or communicable, character of the emotions from which æsthetic expression naturally springs, emphasizes the values of joint experiences and actions of a more or less domestic nature. Group activity of a joyous character celebrating some event or fact of common value is the natural soil of artistic creation in the school as well as out.

Artistic Expression Natural to Children.—4. Expressive activity is also especially adapted for educational use in that the separation, so usual with adults, between the utilitarian and the artistic does not naturally exist for these. In the absence of economic pressure the measure of use is simply value contributed to the enhancement of individual and group life. Cooking, even such seemingly utilitarian things as setting a table and serving a meal, easily take on for children an artistic value so far as they represent a consciousness and commemoration of things to which children attach a vague social significance, all the more potent because in its vagueness

it represents the mysterious and attractive world of adult life. The separation of the externally and technically useful from emotional and imaginative enrichment is unnatural psychological divorce, and one of the chief functions of the arts in education is to maintain the natural union of the socially important with that which makes strong emotional appeal.

Literature the most General Art for School Purposes. — 5. Literature is probably the art most generally available for school purposes. In order that it may be a genuine art it is necessary that it be presented as a consummation and perfecting of factors which the child already appreciates as having value. This means that it is not so much a point of departure for instruction as it is a focus in which other factors gather together in a vivid and ordered way. Literature is not to be used as a means for any other end than this gathering together, in a vital and readily appreciated way, of scattered and inchoate elements of experience. It is not, for example, to be made a means of moral instruction or consciously impressing a specific moral lesson. It is ethically important simply because it presents, in a form easily grasped and likely to be enduring, values which are themselves felt to be intrinsically important. Any attempt at definite formulation and impressing of these values and the kind of conduct they require is certainly detrimental to the literature as art, and is very likely to be harmful to the moral influence which the values might exercise, if left undisturbed in their proper medium of feeling and imagination. The same principle holds, of course, of methods that utilize literature simply as a means of teaching grammar, information about the history of literary men, antiquities, or any of the diverse topics which have been hung upon literature as upon a peg.

METHODS OF TEACHING ART. — Methods of teaching art depend upon the conception of art held and upon the purposes for which the subject is introduced into the curriculum. If the purpose is to interest the pupil in nature or to develop

the power of observation, or the power of coördinating ideas and hand manipulation, as is often stated, no strictly æsthetic purpose is involved and a type of method wholly different from those adopted for the development of artistic appreciation is appropriate. Again, the conception of art, whether it is imitation of nature or the expression of harmonies of form, tone, and color, has a deciding influence on the type of method adopted.

The Two Methods. — Individuals vary and modify the details of their methods of teaching, but all art instruction can be classified under two heads according to the point of view and the principles involved. These systems are radically different in character, affecting the entire make-up and conduct of courses of study. They are, respectively, the academic (analytic), the structural (synthetic). The academic method is a reflection of the professional art school. Its origin may be traced to the later Renaissance. The method is traditional and scientific, making the acquirement of knowledge of nature's facts the first step and the foundation of all progress. The pupil learns to draw, but defers expression until he has attained proficiency in representation. The process is imitative, and the standard external. The structural is a return to the natural method of pre-academic days. It was the method practiced in Europe from ancient times down to the Renaissance, and is still used by the Orientals and by all who are independent of scientific domination. The approach is through structure, — the building up of harmonies of shape, tone, and color, — and the purpose is the development of power in the individual. Self-expression begins at once, involving all forms of drawing, and leading to appreciation. The process is creative, and the standard is individual judgment as to fine relations.

The Academic Method. — The academic method is truly analytic, teaching the pupils "to see," to gather fact upon fact, to store up knowledge, to acquire skill. Its analogue is the old way of teaching language through grammar, rather

than through use of the language. Self-expression in terms of line, tone, and color is deferred, and appreciation is only a by-product. It brings about a somewhat sentimental view of external nature as the source of all art. Whistler's remark that "nature is seldom right" was a blow at this false standard. Critics of the academic school must refer all excellence to nature. For example, they interpret Greek art in terms of fact — making the study of the bodies of athletes the source of artistic power. They measure Japanese art, not by quality, but by truth and perspective. This imitative and scientific system is derived from the eighteenth-century academies and is being followed in our modern academies of art. It owes its origin to the late Renaissance, when creative power was feeble and interest in the sciences dominant. Because one of the greatest of all artists, Leonardo da Vinci, was possessed of boundless curiosity and sought the secret of nature with toilsome persistency, his followers concluded that the pursuit of truth was the basis of art study. Leonardo himself, like all the masters of the Renaissance, was trained by apprenticeship — in fact, by a structural method — to strive for quality and mystery and power in expression. His genius controlled his scientific instruction, and he built all his knowledge into his art fabric.

Continuing the traditional scientific scheme, the academic method in these days requires that schools and courses of instruction be highly specialized. The relation of object drawing, cast drawing, light and shade work, and still-life painting, to mural decoration, house furnishing, costume, handicraft, and the industries is not very clear. It is often forced — for example, the naturalistic flowers in full modeling repeated over wall paper, carpets, and china with no reference whatever to any principle of design. The processes and subjects of academic teaching are good in themselves, but the emphasis is in the wrong place. The tendency is to make art in schools either a pretty accomplishment or an adjunct to some business pursuit.

The Structural Method. — The structural method disregards the theories of the eighteenth-century academicians, and ignores their division of the subject into representative and decorative art. Instead of setting up external nature as the standard, the action of the human mind in harmony building becomes the foundation for study. The elements of space art are shape, tone, and color, the whole visible world being revealed in these terms. Education in space art follows the analogy of music and literature, beginning with structures of a simple order — a few lines, a few sounds, a few words — and proceeding onward by steady growth. Rhythm, subordination, symmetry, proportion, tone values, color schemes are fundamental to all the arts, at least by analogy. From this point of view design, instead of being classed as “decoration,” is seen to be the very primer of art. Nature’s beauties are cases of accidental harmonic structure, to be copied not as a mere exercise, but because they are beautiful and the study of them increases capacity for appreciation, or because they suggest motives for design.

Synthesis (self-expression) is the center of effort, with the sciences as aids. The fine arts of architecture, painting, and sculpture have been developed from industries, not from nature or the bodies of athletes. The beginning and the end is the relation of forms to spaces, not the copying of anything. Greek art, from its earliest to the best period, is an effort in composition — the purpose being to attain finer and finer relations of line and space. When the artists turned their attention to copying facts (human bodies), Greek art disappeared. The same may be said of Italian art, of textile design, and of Gothic art.

What we call art springs from a desire to make things “look well.” The raw materials may be put together in a rude way, for mere use, or may serve a higher use by being put together in a fine way, satisfying a strong desire of human nature. This finer way means ability to make the best choice — and

this comes from the trained judgment. The history of art development shows that whenever the workers constantly improved upon proportion, tone, and color, there was growth into fine art. The simple process of adapting forms to spaces began with painting on clay bowls and carving the handles of utensils or weapons — and ended in the Greek sculptures, the Gothic cathedral, the mural painting. There was no distinction between art and industry, between representative and decorative art.

A course of structural art teaching begins with simple forms of creative work, the pupil drawing upon all nature and all the art of the world for examples. Representation and the sciences become aids to self-expression rather than preliminary exercises, as under the academic system. There is opportunity for immediate application in industry, handicraft, home decoration, and costume.

The structural method of art teaching, though comparatively new in the United States, is not new as a principle. The old system of apprenticeship taught art in practically this form. Art is studied in this way in Japan. The Japanese, however, have introduced the academic system in some of their schools, and the two are conducted side by side. It is significant that designers for the great Japanese industries of lacquer, metal, and textiles are trained by the pure Japanese (synthetic) method. The art of Persia, India, Turkey, China, in fact of the whole Orient, is a higher form of industry, developed without copying nature or historic styles. In the United States the art teaching in professional schools has followed largely the academic method. Normal art courses for the training of teachers have been until recently thoroughly academic, the subjects being object drawing, life drawing, water-color painting (still-life, figure, landscape), pen-and-ink, perspective, anatomy, etc. The inadequacy of this and the feeling that art training must be something more than pastime, together with the increased interest in industrial education, have forced

synthetic methods into many of the normal schools, adding to the academic courses composition in line, dark-and-light, and color, and studies in art appreciation.

The Two Methods in the Schools. — The structural method is now found side by side with the academic in many schools, passing under the name of design or composition. These two influences are reflected in the art teaching in the public schools, with the academic in the ascendant, though evidently losing ground from year to year. The old rigid copy books and the type forms have given way to nature drawing, mass painting, and illustration. These, however, tending to put art among the pastimes, cannot hold the monopoly. Design, with its stimulating application in industry, and the new thought of art teaching as a development of power, have introduced new problems and caused the study of spacing, dark-and-light, and the application in manual training to have more prominence. In the yearly exhibitions of school art the academic influence is seen in mass painting, blotty landscapes in color, dictation exercises in landscape, pose drawing (figures not in action), illustration in crayon, water color, and cut paper. The structural influence appears in designs (for panels, book covers, pages, posters), massing in two and more values, landscape in a few flat tones, illustrations for books, color schemes, pottery, baskets, bookbinding, wood and metal construction, brush drawing, pencil drawing, painting in flat tones with or without outline. Wood block printing upon textiles and paper has been extensively adopted in elementary and secondary schools and in art schools, as a method of studying composition of pattern and of making experiments in color harmony.

DESIGN AS THE SUBJECT RELATING FINE ARTS TO PRACTICAL ARTS. — The relation of the fine arts to the practical arts is made on the educational side through the subject of design. The form of the fine arts most generally found in the schools is that of design. This is because it has both the practical and the artistic relations and values, and because it has the widest appeal.

As related to the arts, design usually implies the planning of the form, structure, and decoration of objects so that they shall satisfy utilitarian and æsthetic demands. The degree to which an object fulfils these demands determines the excellence of its design. The conditions which meet the utilitarian demands are obvious; namely, that the object shall adequately fulfil its purpose. The æsthetic demands are more complex, and generally include utility and the beauty which results from pleasing proportions and outlines, appropriate treatment of material, and suitable decoration.

Industrial Design. — In the constructive arts the utilitarian demand has first to be considered. Until this is met as completely as possible, it is difficult to find in ornamentation any permanent enjoyment which at all compensates for the dissatisfaction arising from imperfect fulfilment of purpose. Attempts to beautify inadequately planned or constructed objects by profuse decoration give an impression of effort misdirected. For example, a chair which is uncomfortable is poor in design. Expensiveness of material and richness of ornament or technical excellence of construction cannot compensate for failure to fulfil the function of a chair, a failure which prevents lasting pleasure in whatever formal beauty may appear in the details. Closely related to this utilitarian consideration is the pleasure in fine craftsmanship which is not content with a crude construction barely sufficient to meet the needs, but which demands also a mastery of tools and processes. The satisfaction that arises from the contemplation of an object which adequately fulfils its purpose and is well constructed readily transcends the crude stage of relief because a need is met, and develops into pleasurable appreciation of the fact that intelligence has shaped raw material into an effective creation by means of clear understanding of its purpose and perfect mastery of the materials. This contemplative appreciation of a well-constructed object which perfectly fulfils its purpose is an æsthetic satisfaction, and thus in industrial

products utility and excellence of workmanship appear as the primary elements of good design.

Design in the Fine Arts. — The conditions which satisfy the æsthetic demands for formal beauty appear to be as follows: Beauty of proportion and outline is one of the chief requisites. Experimentation with the possibilities of different relations of proportions and areas, for example in placing a given number of windows in the front of a house or determining the position of a title to be printed upon a book cover, shows some positions to be so much more pleasing than others that it leads to a definite choice. An analysis of the results generally discovers a consistent thought, not monotonous interrelation of measures, in the case of the pleasing proportions. Experimentation with curves shows also that some give greater pleasure than others, and that in the most pleasing forms the variations of curvature are consistently related. Thus the standards of excellence in proportions and outlines appear to be based, not upon fashion, but upon universal and permanent reasons. An understanding of the mathematical nature of the relations of measures upon which good proportions and curves depend is not necessary to an æsthetic enjoyment of these forms. One may become trained to discriminate almost unerringly between fine proportions and those that are commonplace, without knowing why the results are pleasing, or that any calculable relation exists. The response appears to be immediate in terms of enjoyment, and the adjectives "good" and "bad" as used by the designer with regard to proportions and curves are meaningless except in terms of pleasure awakened.

After the demand for utility has been met, the next important condition of excellent design is this of good proportions and fine outline. The opportunities offered by the arrangement and refinement of necessary parts of the structure itself should be utilized to the full before ornament is added, for in the placing and shaping of essential features lies the greatest

possibility for beauty. For example, in the instance of the chair which has been so planned as to fulfil all the demands of utility such as strength and comfort, there is abundant opportunity, without transgressing these, to vary the position of braces and panels and the shape of the back and arms and legs so that pleasing proportions shall result. These same essential parts may also be so modified as to give the chair a consistent character throughout. It may be solid and heavy, or light and delicate, and yet still outlined by straight lines, or it may repeat curves of a particular sort. When the interest of a skilled and artistic workman continues beyond the satisfaction of utilitarian demands, and he lingers over his work, experimenting with its proportions and outlines till they show the same character throughout, the object gains an individuality which is the basis of style. When the object is one of a kind which the builder repeats indefinitely, he is able to embody in each successive product the hints gained by previous experiments, and gradually to perfect a type. Where many artisans are at work in the same line, a still more thorough exploration of the possibilities of a given theme occurs. Thus styles of architecture, furniture, metal work, etc., have developed.

The same interest that leads to utilizing to the full the possibilities of beauty in the proportions and outlines of the necessary structural elements frequently influences the artistic craftsman to carry the manipulation of his product still further, by playing with and echoing its nature and structural features by such treatment as calls forth the beauty of the materials; for example, the grain or polish of wood and the color or texture of metal, sometimes making even the tool marks a decorative feature, as in hammered metal or carved wood. This interest finds expression also in ornamentation which emphasizes and perfects the style, or symbolizes the history, use, or surroundings of the object. Such ornament is not an accidental or unrelated addition to an object, but an essential expression and organic part of it. Such decoration

as this is clearly differentiated from that sort of ornamentation which results from inability to respond to the stimulus of a perfected idea and which therefore depends upon the barbaric love of heterogeneous collections unorganized by any dominating thought, resulting in a competition of interests. Good design in ornament is not assured by mere technical excellence. For example, an Indian's head may be realistically painted upon a vase, but neither has any organic relation to the other, and neither enhances the beauty of the other. They are competing artistic interests accidentally juxtaposed, and therefore poor in design.

Good industrial design demands that an object adequately fulfil its purpose, that its workmanship be skillful and its construction sincere, that the possibilities of beauty in the materials and in orderly and consistent arrangement and shape of necessary parts be utilized to the full, and that ornament where used shall be a fulfilment or reënforcement of the idea of the object.

Relation of Design to the Arts of Representation. — In painting and sculpture the utilitarian demand is not so evident as in the industrial arts, but is still a prominent element of excellence. The mural painting should primarily be a painting designed for the wall in a sense that is not fulfilled by merely suiting its dimensions to those of the wall and its subject to the surroundings. The technical treatment, the qualities of color, and the disposition of lines and areas must conform to the mural idea. Even the apparently independent easel picture is not at best advantage if it must be made with no regard for its permanent location. Statuary is usually required to be an integral part of an architectural or landscape setting. Some correspondence exists between the subject of a painting or piece of sculpture which determines the kind of response it seeks to awaken, and the utilitarian purpose of an article of industrial art. The appropriate purposes of arts of design are those which cannot be so well accomplished by

literature or music, and are those which depend for their effect not only upon what things are represented, but largely upon such an arrangement of them as shall result in the formal beauty of consistently related areas, balanced masses, pleasing flow of line, and harmonious color. The artist must be sufficiently master of his facts to justify his courage and be convincing when he uses natural material for his own creations, but he must also understand design, or his creation will lack the quality which justifies a modification of facts as presented by nature and distinguishes a work of art from a photograph or cast from nature, namely, that a work of art is the embodiment of a human idea.

Place of Design in Education. — The purpose of a study of design in education is to develop the desire and capacity to enjoy beautiful things, to establish standards of taste, to raise the æsthetic sense from the level of response only to those accidental stimuli which are powerful enough to arrest and hold attention without effort, to an appreciation of what gives increasing pleasure because of elements that are permanent and universal. Such training should result in new sources of enjoyment for the individual, and in a higher standard of industrial products. The production of a great amount of raw material is not so valuable an outcome of civilization as the ability to convert raw material into the highest grade of finished product.

Present School Conditions. — Design has a large place in the elementary and secondary schools of nearly all countries prominent in education. Individual towns and cities, even in the same country, often vary greatly in their methods, but perhaps the most significant and general difference in methods in the United States as compared with other countries is that in the schools of the United States the chief emphasis is usually laid upon the exercise of originality from the earliest years, while in most other countries a broad acquaintance with the best design of the past and a thorough training in drawing from nature and

historic ornament is generally insisted upon as a necessary foundation for originality. In the schools of the United States design has in the past been largely in the field of ornament worked out according to the principles of formal beauty, and used, if at all, as decoration applied to completed objects. Probably this has been true because design has been taught so frequently by a department having no organic relation with that which has taught constructive work. On this account the teachers of construction have emphasized the phase of design relating to utility and technique, while the teachers of art have given chief attention to that relating to the formal beauty of isolated shapes. Under these circumstances the relation of ornament to structure and that other important phase of design, namely, the possibilities for beauty that lie in the disposition of structural parts even where no decoration is used, have often been overlooked. The study of unrelated principles of formal beauty, however, is gradually giving way to an acquaintance with concrete problems which embody all phases of design and offer opportunity to give to each the consideration warranted by its relative value.

The study of design usually begins in the lowest grades and continues through the high and normal schools. The problems are increasingly those related to actual conditions in school, home, and community. The lines of study may be generalized as follows. A consideration of the utilitarian conditions which the problem must meet, experimentation with the forms involved, to discover the best shapes and arrangement, appropriate ornamentation in form and color, and study of the best available examples. The phases of design which emphasize simple decoration with repeated forms, as in borders and surface patterns, are considered as best adapted for the youngest children. Those which call for original judgment as to utility and formal beauty and harmonious color demand increased maturity.

In England and in the leading European countries emphasis

is laid upon the relation of the arts of design to the industries of the country. The present trend appears to be toward developing originality in design. The directing idea underlying this tendency is that design develops best, not when the mind depends largely upon its spontaneous activity, but when it is furnished with the widest possible knowledge as a fund of suggestion. The acquaintance with the best examples and the training in drawing as a means of securing data are much more thorough than in the United States, and design is more intimately related to the industries of the country. The British and European attitude toward the teaching of design is suggested in the definitions of its purpose made by the British Department of Practical Art in 1852, which have not been departed from, and which are practically true for other European countries. (1) General elementary instruction in art as a branch of national education among all classes of the community, with the view of laying a foundation for correct judgment both in the consumer and the producer of manufactures. (2) Application of the principles of technical art to the improvement of manufactures, together with the establishment of museums by which all classes may be induced to investigate those common principles of taste which may be traced in the works of excellence in all ages.

MUSIC TEACHING IN THE SCHOOLS. — The motive that has placed music in the school curriculum has been primarily a humanitarian or social one. There are two reasons for this. The first is negative, due to the fact that the technique which the practice of music develops serves no purpose outside the art itself. In this respect it is unlike drawing, for example, which, while serving as a basis for the fine arts, trains the eye and hand in ways that are valuable for the scientific student as well as the artisan. The second and the positive reason is that music lends itself, especially in concerted work, more perhaps than any other human form of expression, to arousing and expressing a common social feeling.

For this reason it has constantly been looked upon by the schools as an excellent activity for developing and manifesting school spirit.

Recent Tendencies towards a Broader Use and Appreciation of Music in the School. — The tendency in modern education to demand standards and scientific results for what is done would seem at first glance to militate against the increase of musical activity in our schools. This perhaps is true about secondary schools that make the preparation for college their sole aim, but where the secondary school is fulfilling its own task in our educational system, the tendency to broaden the field of music is very evident.

Instrumental Music. — First, with reference to new work, a recognition of the value of instrumental music is growing rapidly. School boards are buying the necessary instruments for carrying on successful bands and orchestras — instruments that are essential to such organizations but are not valuable from a solo point of view and hence would not be likely to be bought by pupils themselves. For instance, Oakland, California, has bought some \$6000 worth of band instruments and has over twenty-two amateur bands in its schools. The Los Angeles school authorities are reported as investing \$10,000 in musical instruments. Brookline, Massachusetts, at the other extreme of our country, has a number of the necessary orchestral instruments as part of the equipment of its high school; and simultaneously in many parts of the country, especially in the West, a like encouragement of instrumental organizations is going on.

But this is not all. Further encouragement is given by the offering of credit as well for work done. Minneapolis, for instance, gives credit for practice on orchestral instruments if the pupil takes at least one lesson a week and attends two school rehearsals and plays at school functions. Not only this, but in many schools, such, for instance, as in Lincoln, Nebraska, private piano and violin lessons, when meeting the

standard set up by the school, are credited as part of the required work of the school. This makes it possible for a talented high school student to keep up his technique and at the same time get a general education.

Parallel with this widening use of music is the increased attention being paid to historical and appreciative courses, having for their main feature the use of the mechanical means that have recently put within the reach of communities so much of vocal and instrumental music that would not have been possible a few years ago. The study of the folk songs and music of a country is now being correlated in a most effective way with its geography, literature, and social organization, and music is thus serving a truly cultural purpose, wider than it has ever been possible for it to do before. More intensive still, but limited to a smaller number of students, are the new courses in composition which are taking the place of the old-fashioned harmony classes and giving opportunity for talented students to discover their ability in composition.

Singing. — While the work described in the above courses is greatly widening and intensifying the influence of music, the main aim, after all, in the teaching of school music is to develop the singer; for in the vocal apparatus we have an instrument that is under the perfect control of practically every one and needs but little work, compared with the playing of instruments, to make such ability effective in chorus singing. The chief obstacle for the singer has been the reading of the musical notation. There is little doubt of the prime importance of this subject, but unfortunately there is a tendency to make skill in sight reading the ultimate test of musical instruction in schools. The accomplishment of such a standard often prevents the necessary practice for both tone quality and rendition that the broader view of music teaching would demand. Not only this, music is also a literature, and it is of prime importance that students who have spent more or less time on music study in the schools during eight to twelve years should

have at least a small but choice repertoire of fine songs that they really know how to sing well, and so thoroughly learned that they will not be dependent on the printed page any more than is the concert singer or player. Unfortunately, such work demands individual attention and musical capacity on the part of the teacher, and where much of the work has been done by teachers of other subjects, this artistic side of music teaching has been necessarily neglected. It is, however, a hopeful sign of educational development that with the broadening of the scope of music there is also an increasing demand for greater æsthetic values as the result of its study. In view of the practically universal scope of vocal music in the schools, the consideration of the methods employed will deal primarily with this aspect of the subject, especially as the part of the work that deals with the structure and notation of music is equally important for the player of an instrument and the student of appreciation and composition.

Methods in School Music. — Methods in music teaching deal with two kinds of activities: (1) What is necessary for producing the music, such as the control of the instrument, or voice, and the understanding of the notation. (2) What is done under the term of “nuance,” popularly called “expression,” and the slight notation that indicates it. The first may be said to deal with the structure of music, the second with its interpretation. It is obvious that the first application of a method in music will be to produce tones, following which there will be a constant effort toward control for expression. This is especially true for the instrumentalist. Even the voice teacher spends the first few years in what is called “voice placing,” practice for producing a good singing tone, before he does much with song interpretation.

In teaching school music, however, this order of activities is reversed. The voice in most children, through the exercise of speech, is already under wonderful control. So the aim of school music is not to produce professional singers with de-

veloped voices, or professional players, but to cultivate a taste for music by good singing and to prepare the individual to aid in the social uses of music. Consequently, it is better to commence with rote songs, or singing by imitation. Two things are thus of special importance in school music: (1) the pupil must know how to render many fine songs in order to develop his taste and appreciation; and (2) he must be able to read from notation.

Interpretation. — Learning songs and learning how to sing them expressively in school is largely carried on through imitation. The pupil is required to match or imitate the model tones given as well as the style or way in which the songs are sung. Supporting this work, the thought of the text and the character of the melody are brought home to the student's mind. Thus his feeling for the thought and the character of the song aids in getting the quality and rendering desired. Besides this work, vocal habits are developed in the pupil based on the distinction between chest and head tones. The former are what the child or youth largely employs in his play, and there is a natural tendency to do the same in music. But when sustained pitch is attempted with this register above B in the middle of the treble staff, the tone becomes hard, and the vocal mechanism strained. The head tone that the child naturally uses when singing above D of the fourth line of the treble staff is clear and sweet. Vocal method in school music is largely concerned in strengthening this upper head tone and developing it downwards. For this reason most teachers agree that scale practice and technical work should commence with the upper part of the voice, with the head tone, bringing this quality down as far as possible, and that the lower tone should be sung softly, developing by constant practice an automatic control of the voice. Thus, the first method in school music deals largely with musical interpretation, and consists in: (1) imitation of a good example; (2) attention to the thought of the composition, both text and style; (3) development of clear head tones.

Structure. — We turn now to the second element in learning to read music. The instrumentalist, by the time he has learned to play, has associated the action necessary to produce the tones with the notes on the staff that represent these tones, so that when he sees the note, he can produce the tone. He can thus, unfortunately, especially if he is unmusical, avoid the necessity of thinking music. The mental process of such a person consists in thinking the physical motions necessary to produce the tone called for by the note, but not the tone itself, which he only hears as the result of his action. On the other hand, the singer has no definite movement in his throat that he can associate with a given note on the staff. F and F sharp feel the same to him. The singer is obliged to learn his notation, not by connecting it with the actions that produce the tones, but by connecting the notation with the way the tones sound. The first few tones heard tend to establish a key to which all the tones that follow are related, the task of the singer being to associate these tone relationships with the notation that represents them. His mental process, instead of being connected with the physical movement necessary to produce the tone, is a thought process; for he must hear mentally the sound that the note represents before he can produce the tone.

As in interpretation the starting point here also lies in imitation. Tone progressions, such as scales or simple songs, are first learned by imitation. These are then sung in connection with their notation, until an association is formed between what is sung and what is seen. Such association is not as simple as it seems, for the notation of music presents three different kinds of tonal relationships: pitch, duration, and metrical grouping. It is through the combination of these three kinds of relationships that the pupil is able to form a concept of the musical movement of his tune. The problem here is essentially the same as that of reading language. From what the notes indicate, the pupil's mind must be capable of forming concepts of the musical movement sufficiently far ahead of what the

voice is producing not to interfere with the even flow of the music. Unlike language, the signs and notes that represent these relationships are not grouped into musical units as letters are combined into words standing for the same idea in whatever combination the words may appear. Every musical unit has its own peculiar combination. The music reader must think these musical units by combining the separate relationships that go to make them up. The most complex part of the training, and the one that requires the closest attention in the methods employed, is concerned with the problem of rapid conception of the tune from its notation. A musical child will often make his associations between the appearance of the notes upon the staff and the movement of the music, so that he is able to read music fairly well, without being able to tell definitely the separate intervals of duration and pitch, representing the musical thought.

Key. — The large majority of people, however, need help in associating the position of the tones in the keys with the notes. Such a device we have in the famous *do, re, mi*, or syllable names, dating back to the eleventh century, and attributed to Guido of Arezzo. This association is made possible when the key is established, the tones of the scale taking on certain characteristics. Since, therefore, a certain syllable is always sung to a certain tone in the key, when the sign for a syllable is written, it suggests the relative tone in the key it represents. The principle underlying this use of the syllable names had a revival in France under the leadership of Pierre Galin, a music publisher of the early nineteenth century, who indicated the relationship of tones by numbers. In England John Curwen utilized the sound names attributed to Guido. In the system thus developed, called the "Tonic sol-fa," the fixed pitch representation of the staff was ignored, and the first letter of the syllables, *do, re, mi*, etc., was printed instead of numbers; for example, *d, r, m*. The spacing of these letters indicated the duration of the tones. These letters, like the numbers, drew

attention to the relationship of the sounds to be sung, and not to any given pitch, and is evidently a vocalist's notation.

The American methods follow the English usage. Some places even adopt the Tonic sol-fa notation as an introduction to sight reading. But the ordinary practice is to use the syllable names with the staff notation. This brings about a complexity that does not exist where the syllables are used with the Tonic sol-fa notation. For reading by note requires a student of harmony to determine the proper relative name from the fixed notation that the staff represents, especially in modern music, which tends to be more and more chromatic, and makes it difficult to determine what the exact key relationship of a tone is. Another difficulty grows out of the constant use of the Tonic sol-fa names, especially where the syllable names have been too slavishly used. The tendency is to associate the tone to be sung not simply with the sight or sound of the name, but with its actual physical production, so that the pupil is able to sing the tune if he can sing sound names, but is unable to think the tune apart from the names. In order to avoid this difficulty many schools use numbers instead of sound names. The objection to this is that the number names do not lend themselves to good tone production, and this method, when too closely followed, is open to the same objection as the use of the sound names. The chromatic tendency of modern music above referred to is making these methods less and less effective.

Interval. — Besides thinking of tones in their relation to key, we may think of them as determined by their distance from each other as intervals of seconds, thirds, and fourths having certain common characteristics. When this has been thoroughly grasped, one is enabled to sing these distances by thinking the nature of the interval. Mr. Samuel Cole of the New England Conservatory in his sight singing course has given specific names for each interval. By always using the name with the interval whenever it occurs, associations are

formed between the interval character of tones and the name, so that, when the interval name is thought, the tones occur to the mind.

Rhythm. — The teaching of duration and time grouping of tones does not present such a variety in the methods employed. The demand on the pupil, unlike that of thinking pitch relations, is identical for both singer and player. A few fundamental differences in tone lengths are used over and over, whatever the key, although confusion is caused to young students by changes in the note used to represent the beat. This difficulty is being reduced, there being a tendency among publishers to use uniformly a quarter note to represent the beat in simple time. Besides beating the time, other physical movements for strengthening the feeling for pulse in music are being employed in a more varied way.

In Europe much interest has been awakened by the work of M. Jacques Dalcroze, who has developed a remarkable feeling for rhythmic character through dancing and gesture. Movements of the march and folk dance are advocated for developing rhythmic feeling as a support for musical work.

Present Procedure. — The pressure of more and more studies in the school is tending to lessen the time given to singing. A fair average allotted to this subject is one hour a week. This is sometimes given in two half hours, sometimes in fifteen-minute periods. This hour is often supplemented by another period of music work and general exercises. The music study period generally commences with some breathing exercises, followed by scale and vocal practice. Then technical matter pertaining to notation is followed by reading new music or exercises, and the lesson ends with a review of familiar songs.

In the first stages, whether in elementary or high schools, learning songs by imitation, or "rote singing," as it is called, is largely emphasized, and in some schools this is carried on in diminishing extent through subsequent grades. This makes it possible to introduce a great deal of excellent music, which

might otherwise be too difficult to read. On the other hand, those schools employing sight reading do little rote work after the first year, paying much more attention to the singing of exercises intended to improve sight reading. This procedure reduces the artistic musical material used, but tends to increase the proficiency in reading. In either case, much depends upon the amount of individual work demanded from the pupils. The great difficulty in accomplishing any thorough teaching along ordinary lines lies in the fact that music is universally taught collectively, thus reducing the individual responsibility to a minimum, so that students can go through years of school work, and at the end be unable to give the simplest description of what they have done.

New Tendencies. — The new trend in modern education is bringing about a decided change in the attitude toward the popular teaching of music. This change in aim puts the emphasis not so much on what is taught as on what the pupil can do with what he is taught. The point of interest is the pupil rather than the subject. Under this new influence the teacher aims to make the tone quality, the dynamics, the pronunciation, and the musical form, as to both pitch and rhythm, grow out of one central thought, — the expression of the feeling suggested by the words of the song. The child must sing it in a way to show that he realizes the significance of what he does.

But this is not all; the child must not only make the musical thought of another his own, but he must have experience in expressing his own poetic and musical thought, not that in so doing he can express anything of value for others, but for the sake of the musical development both in thought and taste that such practice brings about. It is parallel to theme work in the teaching of the mother tongue. This attitude toward music treats it more as a language, and seeks to make the form expressive of the feeling. In making a melody fit the words of a song the child is constantly led by the teacher to

observe the relationship between the music and the text. Such effort on the part of the pupil brings about the most searching observation and thought with reference to the song he is producing. When such song-making is the collective effort of the whole class, different members offering their versions of the wording and thought of their couplets and their melodic expression there is a much more intensive exercise of æsthetic faculties and discriminative thought than ordinarily takes place by the old methods.

Thus the new methods seek to develop the poetic, imaginative, and discriminative power of the pupil in his relation to music, laying the basis for musical appreciation, which after all is the most important use to which the pupils in our public schools will put their musical education.

TOPICS FOR FURTHER STUDY

1. What evidences are there in the life of the adolescent child or in the activities of modern society to indicate that the art interests and instincts are fundamental?
2. What are the anthropological and historical evidences that the art impulses and interests are fundamental and of educative significance?
3. What activities of the school or of the life of school children of the adolescent period possess educational value for æsthetic ends?
4. What are the comparative values of the analytic or academic and the synthetic or structural methods of art instruction as revealed by a study of any given school system?
5. Outline in detail a course of study according to each of the two methods (analytic and synthetic). What are the educational advantages and disadvantages of each?
6. What practical methods for the development of art appreciation among the high school pupils might be employed in your own community or any selected community?
7. What are the values and advantages of the methods of teaching art in any one European country compared with those in vogue in America or in any selected American city?
8. How can the art work be correlated with the other activities of the school? The music work?

9. Work out the exercises of a course in design relating the fine and the constructive arts.

10. What opportunity or demand or need is there in present American life for instruction in design for secondary school pupils? How can these needs be correlated with work in the schools?

11. Trace the development in purpose, conception, and method of instruction in art and music in any selected school system.

12. What is the place of instruction of music in the high schools? How does it differ from its place in the elementary school?

13. What criticism or suggestion can you make on the music work in any selected city school system or high school?

14. What place should the modern mechanical methods of music representation have in the schools? Give advantages and disadvantages of their use.

15. How can instruction in art and music be used as a means to moral instruction and character building?

REFERENCES

Fine Arts

- American Art Annual*, 10 vols., 1898-1913. F. N. Levy, editor. Biographies of American Painters and Illustrators and Crafts Workers. Art Schools and Organizations, Art Sales, etc. New York.
- Art and Industry*. I. Edwards Clark, editor. 4 vols. Part I, 1885, *Drawing in Public Schools*; Part II, 1892, *Industrial and Manual Training*; Parts III and IV, 1897-1898, *Industrial and Technical Training*; Bureau of Education, Washington, D.C.
- Art Education in the Public Schools of the United States*. J. P. Haney, editor. London and New York, 1908.
- BARNES, EARL. *Studies in Education*. 2 vols. Illus. Stanford University and Philadelphia, 1897.
- COLIN, PAUL. *Enseignement des Arts du Dessin*. Paris Exposition universelle, 1889. *Rapports du jury internat'l*, 1890-1892, Vol. VI, pp. 121-1248.
- COURAJOD, LOUIS C. L. *Histoire de l'enseignement des arts du dessin au XVIII siècle; l'École royale des élèves protégés*. 8vo, Paris, 1874.
- DOW, A. W. *Composition*. 7th ed. New York, 1913.
- Theory and Practice of Teaching Art*. Publication of Teachers College, New York, 1912.
- GOTZE, W. *Das Kind als Künstler*. Hamburg, 1898.

- GREAT BRITAIN. COMMITTEE OF COUNCIL ON EDUCATION — Science and Art Department. *Directory* with regulations for establishing and conducting science and art schools. London.
- Instruction in Fine and Manual Arts in the United States. Statistical monograph; H. T. Vailey, editor. *Bull. VI*, 1909, U. S. Bureau of Education, Washington, D.C.
- Jahrbuch für den Zeichen- und Kunstunterricht*. Edited by G. Freise, Hanover.
- KERSCHENSTEINER, G. *Die Entwicklung der Zeichnerischen Begabung*. Munich, 1905.
- LEREZ. *L'Art et la Poésie chez l'Enfant*. Paris, 1888.
- Proceedings Eastern Art Teachers' Association* (now Eastern Art and Manual Training Teachers' Association). 6 vols., 8vo. Pub. by the Association, E. E. Struble, Sec. Newark, N.J.
- Proceedings National Education Association*. Annual; see Reports of Department of Art Education. Pub. by the Association, Winona, Minn.
- Proceedings Western Drawing Teachers' Association* (now Western Drawing and Manual Training Teachers' Association). 16 vols. Pub. by the Association, W. T. Bawden, Editor, Normal, Ill.
- Report of Examiners, National Competitors, Board of Education, South Kensington*. Annual. Wyman and Sons, London.
- School Art Book*. Monthly magazine. 9 vols. Illus. Pub. by the Davis Press, Worcester, Mass.
- SPARKES, JOHN C. L. Schools of Art, their origin, history, work, and influence. In *Report International Health Exhib.*, Vol. 8, pp. 721-880. London, 1884.
- Transactions International Art Congress*, Vols. 1900, 1904, 1908. Vol. III, 1908. Pub. by the Congress, 151 Cannon St., London, S.C.
- Yearbooks of the Council of Supervisors of the Manual Arts*. 7 vols., 8vo. 1901-1907. Illustrated Studies in Art Education by various writers, Pub. by the Council; address E. D. Griswold, Hastings-on-Hudson, N.Y.
- It is to be noted that practically all the large cities in the United States and England publish their art courses of study for the public schools; various cities and localities on the continent do the same.

Design

- BATCHELDER, ERNEST. *The Principles of Design*. Chicago, 1904.
- CHRISTIE, Mrs. A. H. *Embroidery and Tapestry*. New York, 1906.
- COCKERELL, DOUGLASS. *Bookbinding*. New York, 1902; London, 1906.

- CRANE, WALTER. *The Bases of Design*. London, 1898.
 DAY, LOUIS F. *Nature in Ornament*. 2 vols. London, 1894.
 DOW, ARTHUR W. *Composition*. New York, 1905.
 JACK, GEORGE. *Woodcarving*. New York, 1903.
 JOHNSTON, EDWARD. *Writing, Lettering and Illuminating*. New York, 1906.
 ROSS, DENMAN W. *A Theory of Pure Design*. Boston, 1907.

Music

The Voice:

- BATES, JAMES. *The Care and Use of the Voice*. London, 1907.
 ELLIS, A. T. *Pronunciation for Singers*. London, 1888.
 HENDERSON, W. J. *The Art of the Singer*. New York, 1898.
 HOWARD, F. E. *The Child Voice in Singing*. New York, 1898.
 JONES, DORA DUTY. *The Technique of Speech*. New York, 1909.
 MILLER, FRANK E. *The Voice*. New York, 1910.
 RIX, FRANK R. *Voice Training for School Children*. New York, 1910.
 RUSSELL, LOUIS A. *English Diction for Singers and Speakers*. Boston, 1905.
 TAYLOR, D. C. *The Psychology of Singing*. New York, 1910.

Methods:

- CADY, CALVIN B. *Music Education in Outline*. Chicago, 1902.
 CRANE, JULIA E. *The Manual of the Music Courses*. Plattsburg, N.Y., 1909.
 FARNSWORTH, CHAS. H. *Education through Music*. New York, 1909.
 FORSEMAN, ROBERT. *Lyric Music Method*. Chicago, 1914.
 GIDDINGS, T. P. *School Music Teaching*. Chicago, 1910.
 HARDY, T. MASKELL. *Practical Lessons in School Singing*. London, 1906.
 NEWTON, E. W. *Music in the Public Schools*. New York, 1909.
 New York State Education Dept. *Syllabus for Secondary Schools*. Albany, 1910.
 RIX, FRANK R. *Manual of School Music*. New York, 1909.
 SMITH, E. *The Eleanor Smith Music Course Manual*. New York, 1908.
 TUFTS, J. W. *A Handbook of Vocal Music*. Boston, 1896.

CHAPTER XVI

HOUSEHOLD ARTS

PRACTICAL ARTS IN EARLY EDUCATION. — In the early days of our educational history the work in practical arts was carried on at home. We laud the “little red school house” and point to the famous men and women who received their training within its walls. But we are forgetting that their best training was gained, by the boys in shop or field, and by the girls in a home, under the efficient guidance of a homemaker; — a homemaker who realized that a home was the place for the rearing and training of children. There was no need of Montessori methods, for the little ones learned to button their own and their brothers’ and sisters’ pinafores, and the busy mother had no time to interfere with the child’s self-activity. There was no demand for industrial arts in the elementary grades, for the children participated in the simple manufacture of the materials and equipment necessary to their daily life. The girl learned of textiles in no artificial fashion, but was thoroughly acquainted with the whole process in the production of the wool which she made into her winter dress. She understood detergents and dyes, for both the soap and the indigo blue were made at home. The girl spun and wove, knitted and embroidered, made dresses and the lace with which to trim them. She not only learned to make bread, but she made the yeast as well. She understood food preservation, for its learning was motivated by keen necessity.

The “little red school house” then fulfilled its function well in teaching the three R’s. Pestalozzi wished the home

and the school to be supplementary to each other. His school curriculum included some work in the practical arts because the home was even then neglecting these industries. Our schools are still seeking to supplement the home, but the industrial processes have been largely removed from the home and the home often converted into a mere lodging house for the family. This striking change in the character of home life, whatever causes have contributed to it, is at the bottom of the great educational problem. It accounts for the ever increasing paternalism of the schools. It compels the schools to introduce carefully planned work in household arts, if girls are to enter life well equipped.

BROAD CONTENT OF HOUSEHOLD ARTS. — The well-being of a democracy demands that all should have an opportunity to become informed upon subjects affecting the prosperity of the community. A knowledge of how men and women earn a livelihood is essential to an appreciation of the dignity of labor. In some way schools have failed to make their students realize that there is dignity in all forms of honorable labor. Any educational system that registers such a failure among its products is fundamentally unsound, if not actually vicious. Social sympathy and stability must be secured by putting work in its proper place of honor and by imparting a knowledge of the conditions that govern that work. It is quite as important for the girl to be trained in citizenship as for the boy. We have come to recognize that development of the individual is not a matter of sex, that all children have a right to be well born, well fed, sheltered, and clothed, and that all, regardless of sex, must be given the opportunity for free and full development. In order to meet present-day conditions, the girls need training for life. Our conception of the scope of household arts has been enlarged, therefore, to include the larger housekeeping, and each department and process growing out of homemaking must be studied as affecting not only the individual home, but the homes of the community.

House sanitation concerns a girl in her own home, but she must be also concerned with the housing problem of the tenement. Feeding her own children is by no means her whole duty, for the milk and other foods which she will buy come from the same sources that feed the poor. This common source becomes her responsibility. Knowledge of food values should not be restricted by sex, for though one may never cook a meal, food must often be selected from a menu card and the proper selection is of greatest importance. The course which deals with cookery only becomes trade training as distinguished from household arts education. Education in household arts is for a business which lasts as long as life lasts, and through it one should find a purposeful share in the outside world's work. The household arts prepare girls for good citizenship and make of them active workers in bringing about better living conditions for all.

The Purpose of the Household Arts. — Household arts treats of the final distribution, the ultimate preparation for use, and the consumption of the earth's products. It aims to enlarge the sum total of human happiness by improving the average of human health and increasing the purchasing power of the small purse. It seeks to teach values, to teach methods in the preparation of materials used for food, clothing, and shelter, to teach the principles of hygiene and sanitation. This is an age believing in prevention rather than in cure. Realizing the soundness of such belief, household arts endeavors to teach the child the principles of right living, so that she will become healthy, happy, and efficient. It tries to teach economy in the home management, and this by neither skimping nor doing without. It seeks to teach the purchasing power of the individual purse, not so much in the number of pounds of flour or beef that the contents of the purse will buy, but in what, in terms of caloric or food value, the purse holds; not so much how many yards of cloth or ribbon may be purchased, but such a knowledge of textiles as will enable the purchaser to

secure a fair value. It includes the study of the consumption of time and energy, since efficiency is as necessary to the proper management of the home as it is to that of the factory. The big directing purpose of household arts may be defined as a desire to improve social conditions through teaching the effective control of physical environment.

SCHOOL WORK SHOULD CONNECT CLOSELY WITH LIFE. — Training in household arts should fit actual life conditions. This is a necessity. The teacher must know the home conditions of the individual members of her class before she can adapt her work to their needs, but she must also know the home conditions of the community at large and point the way for coöperative work, for without some such knowledge she is in danger of educating her girls away from actual conditions. The kindergartner, by means of her home visits and gatherings of mothers, is exerting a greater influence in the home than is the teacher of household arts. The Mothers' Associations might easily include the parents of older students. The kindergartner would welcome the assistance of the household arts teacher, not only in the program, but also on the social side, which is always more intimate when combined with appropriate refreshments. The mothers might accept suggestions from their daughters concerning things learned in a domestic science lesson if they were acquainted with the teacher and respected her opinion.

A word of warning may be in place. The teacher will not gain the mother's respect unless she is willing to give a respectful consideration to that mother's home methods. Unless very careful, the teacher may quite unconsciously offend some foreign mother. Furthermore, social workers claim that much of the lawlessness of children of foreign parentage is due to the loss of filial respect, engendered in our schools through lack of considerate attention to the customs of other nations. In a cookery lesson, it is wise, after giving the fundamental principle in the effect of heat upon a given food-

stuff, to illustrate or at least indicate the different modifications in its preparation or service in other countries. Often the same dish is merely cloaked with a different name. Similar consideration should not be neglected in the study of costume or housewifery. Comparison of methods, eliciting the good from each, is a quick way of securing mutual respect and social sympathy.

CLOTHING AND HYGIENE.—The Gertrude of Pestalozzi was most careful of the toilet of her children. They were taught habits of neatness, the arrangement of their hair and the condition of their dresses was a part of the teacher's responsibility. The domestic art teacher presents no new principle of education when she introduces talks on personal hygiene and gives instruction in the care and maintenance of the wardrobe. Habits of dress have an economic importance far in excess of the cost of cloth per yard or the size of the milliner's bill. It is of primary concern that the girl who is entering a business or professional life possess an attractive personal appearance; an appearance neat, appropriate, and becoming. She will find this a decided asset in securing not only employment, but the respect of her employer.

Blind and stupid following of fashion is to be met by instruction in costume design and color harmony. The study of proportion and form carried out in garment construction will train the girls to an appreciation of beauty and appropriateness. The study of domestic art, however, should go below the surface and deal with both toilet and dress. A study of the proper kind of corsets and shoes is as necessary as the consideration of those garments which the girls themselves may make in the classroom. This whole subject of dress should be in close coördination with that of physiology. An ethical question is also involved which must not be passed by. Every teacher of household arts has a heavy moral responsibility. Clean-minded men remonstrate, while others stare, at the hobble or slit skirt, the extremely low neck, the ab-

surdly short sleeves, and the high-heeled pumps so commonly worn. This is a fact not to be controverted, a fact presenting a problem more important than sewing or pattern drafting. Teachers of household arts should recognize this. They should go further than cultivating an appreciation of the beautiful, the becoming, the appropriate, and not hesitate, from any false modesty, to teach true modesty. It is admitted that home is the best place for such instruction and the mother the proper one to give it. Unfortunately some girls lack proper home environment and even mothers; and all girls discount what is told them, until, through study, the fundamental laws impress upon them the wisdom of what their mother said. If the students' brothers and sisters are taken as concrete illustrations, care and clothing of infants and small children can be taught in a way to avoid self-consciousness. Older sisters have a great influence on the younger, and the "little mothers" thus secure a training that will later stand them in good stead. It is more important for them to know how to bathe the baby, dress it properly, and use the power of suggestion in the formation of its habits, than to embroider a petticoat or make Hollandaise sauce. Whether the girl marries or not, she should bear her part in the prevention of infant mortality, and a knowledge of child hygiene will make her an intelligent worker both in her home and civic life.

FOOD AND NUTRITION. — Satisfaction is felt in the ownership of a body and brain, only when the mechanism of the body runs smoothly and supplies due energy for the mind to apply. That energy is secured by the adequate intake of air, water, and food, and the proper elimination of waste. We eat to live; the direction of that life and energy is another problem. Efficiency, however, is to be secured only through the maintenance of nutritive equilibrium. The food for infancy is nicely balanced by nature in the mother's milk, and the food of the mother affects this supply. It is acknowledged that much of the sickness or failure to nourish the

child properly comes from ignorance on the part of the young mother, which might have been avoided by a little timely instruction. Lack of natural food and the necessity of artificial feeding is a large factor in infant mortality, and, therefore, the food for infants and small children is a practical and most important phase of household arts instruction. Food habits are acquired early and need guidance and direction. Malnutrition is prevalent among the wealthy as well as among the poorer people. This is due to ignorance of the proper food to buy rather than to a lack of money with which to buy it. Increased facilities of transportation have brought to our doors the products of every clime; a new problem, that of choice, has been laid upon the homemaker. This requires a knowledge of food values and food requirements.

The housewife must have an appreciation of what constitutes cost and its contributing factors, for the price one pays for an article may be no criterion of its food value. Cheap food is not necessarily either unappetizing or lacking in food value. The cost of production and manufacture, the keeping qualities, ease of transportation, nearness to markets, all influence the price placed upon an article. Cleanliness in the handling and delivery of goods increases the cost legitimately, and cleanliness is worth paying for. Sanitary science is closely linked with the marketing problem.

Technical Skill to be Gained.— Skill in manipulation should be secured through individual work under conditions calculated to develop responsibility and initiative. It is important that the individuality of the young cook be encouraged. While the fundamental principles in the application of heat to foodstuffs are definite, the art of cookery is the result of imagination applied to "tasteful" combinations, attractive forms, and interesting seasonings. There are but a limited number of foodstuffs, and any girl who succeeds in modifying some monotonous dish or inventing a new one has conferred a blessing upon humanity. The correct serving

of simple meals is of equal importance with their preparation. These should be appropriate to the lives of the girls, and all display of fancy cookery should be carefully avoided.

Scientific Knowledge. — The girl attending a secondary school cannot be expected to comprehend organic chemistry such as is involved in food composition. She lacks the maturity necessary to become scientific minded. When the attempt is made to teach her food chemistry the usual result is a superficial understanding or a memorizing of sweeping generalities. She cannot appreciate the intermediate steps in such complicated chemical changes and is apt to believe that her knowledge of results indicates a mastery of a subject, which, in fact, she has scarcely entered. There is a thought content to this work, however, of such practical importance as to demand attention. A knowledge of the general classification of foodstuffs and the effect of the heat as applied in the processes necessary to their preparation for the table is essential. The changes in the foodstuffs thus affected must be considered with reference to appearance, texture, taste, digestion, and metabolism.

Waste. — Waste is a topic of especial importance, affecting the cost of living in more ways than are usually recognized. The self-evident waste in the garbage can is the most easily governed. Skillful preparation of left-overs can be taught satisfactorily, but the avoidance of left-overs is more sensible. To buy or cook a larger quantity than is needed is evidence of bad management, but the application of the wrong degree and quantity of heat in the cookery of a given food may render it difficult of digestion and necessitate the utilization of a disproportionate amount of energy in order to bring it to a form capable of absorption, and there is also apt to be a high percentage of waste in undigested material. It is a truism to say that it is not what we eat, but what we digest, which nourishes us. Water and air are important factors in body nutrition and elimination, and if these are unclean or in-

sufficient, arrested development and illness are likely to result.

Prevention is the keynote of this study, the prevention of the human ills which are so costly in their cure. To quote from Mrs. Richards: "The healthy, happy person is not liable to be a criminal. Prisons and reformatories are filled with those whose twisted nerves and starved muscles mean knotted brains, and troublesome, uncontrolled impulses." Is it not true economy for a community to prevent by adequate instruction the production of this class?

HOUSING CONDITIONS, HOUSE PLANNING, AND HOME KEEPING.—Increasing numbers of people are crowding into cities which are already badly congested. This extreme congestion has caused housing conditions under which health and strength have small chance for development. Investigation shows that disease and death are in direct proportion to the light and air space in the tenement, and that criminality grows where unsanitary housing conditions exist. Infant mortality in houses fronting on alleys is nearly three times that in houses fronting on streets. The problem thus presented is an intensely human one, as the efficiency of our citizenship is dependent upon the decent housing of our people. The coming generation must be instructed in house sanitation. Our schools now contain the future landlords and tenement dwellers. In the schools, then, the work must be done.

Proper ventilation is of first importance. The need of a sufficient supply of clean air for breathing creates a problem as grave as that of securing clean water for drinking or for bathing. The schoolgirl should be taught these facts and given some knowledge of heating, ventilating, and plumbing systems.

Care of the sick should be taught. This training includes practice in proper bed making, bathing, emergency bandages, poultices, compresses, and first aid to the injured. There is no attempt to develop professional nurses, but rather an

effort to make every woman able to meet the accidents which occur, and to care for small ailments which do not require a physician's attendance. Physicians claim that the lack of proper care and feeding often sends a patient back to the hospital a second, and even a third, time. Moreover, the work is preventive. Such a high school course might also constitute prevocational training for professional nursing in private institutions, or public welfare nursing.

Moral and Economic Values of Such Instruction. — The physical environment of individuals has an undoubted effect upon their character, happiness, and health. A pleasant view from the dining-room windows affects the flow of digestive juices and the consequent ease of digestion. Unpleasant environment, either social or physical, is often the cause of malnutrition and indigestion. Harmonious coloring of walls and hangings, pleasing pictures, and comfortable furniture are of economic and social importance. These cost no more in dollars and cents than their opposites. Indeed, the uncomfortable furniture and inharmonious decorations may cost more. The important thing is that the girl understand the principles of æsthetics and be trained in their application to life.

The paths to be traveled in performing the common duties of housekeeping must be studied in order to save steps and confusion. There are so many calls upon the time and strength of the housekeeper that conservation of both should receive the careful attention of those who are qualified to advise and teach. The homemaker of the future will be a household engineer, acquainted with the labor-saving devices and equipped to apply these through her knowledge of physics and electricity. This will be letting her head save not only her heels, but her hands and her time. Efficiency and scientific management are more important in the home than in the factory, where the product is less important than that of the home. Again we have here a fundamental prevocational training for institutional housekeeping.

EQUIPMENT. — A school system is frequently erroneously judged by its handsome buildings and elaborate equipment, when too often these are but proofs that the school is training girls away from the home and real life rather than for it. Over-equipment is worse than under-equipment, for the latter at least develops initiative and resourcefulness. The average woman in most localities will not have an electric stove in her kitchen for some years to come; therefore, the girl needs to learn the control of that type of stove with which she will probably have to deal. Neither should the adequate equipment for teaching household arts be looked upon merely as expense, but rather as investment. No investment can be more safe, nor guarantee a surer and larger interest. Usually lessons requiring the use of the oven fail to put responsibility upon the individual students, because of an inadequate number of ovens. Baking bread and roasting or broiling meat are fundamental processes which all should master. Educating away from the home is also evident in the use of sewing machines too expensive for the average home to afford. This criticism is a plea for sound economy, and not at all intended to encourage the purchase of cheap equipment which in the end must prove a poor investment. A low cost is by no means synonymous with economy.

The furnishings of the school fitting for life in rural communities should be adapted to rural conditions, while those of the urban school must be adjusted to the conditions found in tenement or flat. One of the most needed reforms in every home is a more convenient arrangement of kitchen equipment. The proper juxtaposition of stove, sink, and cupboard saves hundreds of steps. The drain board to the left of the sink means the saving of several extra motions in the washing of each dish, while the proper height of sink and table means less backache. Proper ventilation prevents overheating, and a fireless cooker secures economy of time and fuel. A sink of the right type equipped with drain basket can be con-

verted into a modern dish washer and lessen what is considered by every one to be the most unpleasant part of housework. A school equipment made up of many units, each a complete kitchen providing opportunity for individual work, will develop self-reliance.

Elimination of the Artificial. — As the teacher of commercial subjects is confronted with the problem of eliminating the artificial so that he may make the work approach most nearly to actual business, so the household arts teacher must struggle with the same difficulty in her own field. In either case, unfortunately, there must remain too much of the artificial. The students are too old not to realize the make-believe, and as a consequence are slow to acquire any vital interest. Various plans have been devised to offset this difficulty, one of which is the use of an apartment or group of rooms where the girls may actually keep house. The cooking laboratory furnishes too little opportunity for testing the girls' habits of neatness and orderliness. In the apartment, which should be furnished for use and not for display, not only the ordinary duties of the housewife may be performed, but the æsthetic and social side may also receive due attention.

Value and Results of Training in Housekeeping. — This work in household administration necessitates the most careful planning, and must be conducted by a teacher well acquainted with her subject. If the apartment is wisely selected, much may be learned of wall and floor treatment, of house sanitation, and of plumbing. The selection and arranging of simple furniture teaches the girls how to economize both time and energy. Division of income and household accounts assume a real interest to the group of girls living as a small family. Marketing is taught by actual doing, and the division of income tested by a real balance sheet. But at best this too is make-believe, and whenever the girl can be stimulated to use her own home as the laboratory for her practical experience, a school can well afford to credit such

work. This plan has been actually worked out in several places with success and is to be recommended. Wherever there is coöperation with institutions or organizations concerned with the professional or business use of the processes growing out of housekeeping, the students secure control of the processes and confidence in themselves; but best of all they come to look upon this work of housekeeping as a profession or a business. There is no questioning the better attitude of the trained homemaker toward housekeeping and child care as compared with the one who is ignorant of the possibilities. She sees that it is a business worthy of her best effort and mental capacity. She is willing to invest in it and she finds joy and satisfaction in attacking the problem. Keeping accounts is not for her a matter of accounting to another for moneys received, but rather one of money invested in a business which she is anxiously interested in making pay.

EXHIBITIONS. — Too much time and energy are given to the preparation of work for exhibition. An exhibition can only be material at best, as the really effective work of the department cannot be displayed in any such manner. The exhibition can be justified only on the ground that it may act as some stimulus to student endeavor and may offer the public some concrete idea of what their children are doing. Unless supervisors are watchful, the teacher's work will be much handicapped by the thought of some annual exhibition. Indeed, not only will time and energy be wasted, but there will be great danger of her losing sight of the purpose underlying the work. She will work for the exhibition instead of for the girl. The wisely arranged exhibition will show what has been accomplished by the poor and mediocre as well as by the excellent students. Failure to make it thus inclusive means that the public must be misled and the students given a lesson in bad ethics. To repeat, the planning of the year's work should not be affected by a possible exhibition looming up ahead. If that work reaches the vital needs of the girls

and harmonizes more and more closely with the actual conditions, there will be an abundance of material for a creditable exhibition. School principals are often the ones at fault. By their ambition to make their school show material results, the teacher is forced against her better knowledge to accede to their wishes.

TEACHERS. — In the last analysis, the success of any scheme of education depends upon the teacher. All departments of school activity are continually calling for better teachers, but perhaps none of them are in such need as the comparatively new department of household arts. It demands teachers with vision and character as well as thorough technical training. A housekeeper, a dressmaker, or a young woman clever at sewing or cooking is not necessarily a good teacher of household arts. The good teacher must, of course, have a natural or acquired deftness in the management of needle or rolling-pin, but she must also be well trained in the principles of chemistry, physics, biology, physiology, psychology, sociology, English, mathematics, economics, and pedagogy. The department has suffered, because of its newness, from certain types of teachers. One is the woman who, after years of teaching pure science, has taken up the subject too late to become skillful on its technical side. Another is the trade worker, who may possess high manual dexterity combined with good taste, but who necessarily has the trade point of view, which is narrow, if not selfish. A third type secures a position through influential friends and then hastens to a summer school, there to receive a smattering of the subject, which, combined with bluff, will carry her through. Still others, after failing as teachers of the humanities, have shifted to household arts work, wrongly believing that it requires less capacity. Finally, in this department, as in all others, teachers may be divided into two classes — the job teacher and the professional teacher — one working for salary only and the other for the girl as well.

Probably no other department, barring that of physical training, touches the lives of the girls so intimately as this. It is of the utmost importance, therefore, that its teachers should be women of vision, refinement, and consecration; women who know the meaning of life and the dignity of labor, and who appreciate the aim of household arts. Fear the issue one may, but avoid it one dare not, — that seriously important necessity of teaching our girls of the dangers to be met, diseases to be avoided, disaster to be escaped, and death to be prevented. It takes the highest type of woman to approach girls on the subject of social prophylaxis, and much harm will be done if the instruction be undertaken by one less pure in mind than the girls themselves. Mothers are shirking their duty or are unqualified to perform it, but the ethical responsibility remains. Wise legislation can do much, but it cannot lift the individual duty we owe in protecting the womanhood and motherhood of succeeding generations. If the teaching of sex hygiene is deemed advisable, let us frankly face the question and, as we can, work out the best method of bringing our girls to a sane comprehension of the responsibility they hold, the self-respect they must maintain, to guard their womanhood. There should be no roughshod methods, and we question the advisability of class instruction for the self-conscious adolescent girl. Only mature wisdom can dictate the psychological moment, but the household arts teacher should not neglect her opportunities.

Women who have taken their degrees as Doctors of Medicine and others who are graduates of the best schools of household arts, confess that they failed to make the application of physiological facts themselves. The bridging over between theory and life is not being accomplished, and girls enter married life quite ignorant of its responsibilities. There may be found here one means of combating infant mortality and of diminishing the number of unhappy marriages. This really amounts to vocational training, but for a vocation which from the

time of the cave woman to the end of human existence must belong to woman.

THE HOME IDEA MUST BE PRESERVED. — The application of steam and electricity to transportation, communication, and manufacture has altered the human environment more in the last three quarters of a century than had been done in the six thousand years preceding. These changes have been made manifest in the home in many ways. Though industries have been removed from the home, the absence of the industries has not destroyed the home, and if in the course of events other processes should be taken away, indeed, if even the kitchen stove and the sewing machine should become useless, it would still be home, because home is a place for the shelter, privacy, and rest of a group of individuals bound together by ties of affection.

In the final analysis, that which makes the home is not purely material, and teachers of homemaking must never lose sight of this fundamental truth. From the economic standpoint alone, the home cannot successfully compete with a larger grouping of individuals. If material wants are to be satisfied, man will go where that satisfaction can best be obtained, and this will not be in the home. If one believes that the integrity of this country is dependent upon the integrity of the home, he must realize at once the vital importance of teaching the young how to preserve that home. The home developed from a feeling of the need of protection, and it still has that ideal, but the office of a real home is also to teach right habits of living, as well as to develop individuality and responsibility. Though the home of to-day may be different in outward appearance from the home of yesterday, it still offers an opportunity for the development of obedience, reverence, unselfishness, and love.

This ideal has been set for all teachers of household arts by the pioneer worker in the application of science to the home. Mrs. Ellen H. Richards states: "When mothers become so

careless or ignorant that half their children fail to reach the first birthday, and of those that live to be three years old, a majority are defrauded of their birthright of health, some agency must step in. If the state is to have good citizens, it must provide for the teaching of the essentials to the generation that will become the wiser mothers and fathers of the next."

VOCATIONAL ASPECT OF HOUSEHOLD ARTS.—

Large numbers of girls who complete a high school course of study must immediately enter some wage-earning position and are therefore forced to seek information and training for economic ends. A still larger number have been entering the field of industry immediately after leaving the grammar schools. Legislation is being quite generally enacted to retain the girl in school, and the school must therefore see that her time is profitably spent in preparation for a vocation.

The Trade School.— The Manhattan Trade School in New York City paved the way for others of a similar character in New Britain and Bridgeport, Connecticut, and in Worcester, Massachusetts. "These short-term trade schools with necessary academic and specific intensified trade courses are for those who must become wage earners as early as possible. The Worcester Girls' Industrial School has lengthened the course to two years. Wage earning is the goal and not home dressmaking. Quality and speed are the two points emphasized in order that the tasks may bring adequate returns."

In view of the facts that of the seventy-five thousand women workers allied with women's trade unions, twenty-two thousand are permanently out of work all winter, and that of all industrial workers among women not a tenth are allied with trade unions, it is a pretty safe estimate to say that at least one hundred thousand women workers in industries are out of work in the big cities of the East today. When one realizes that more than twenty-two thousand are working on

half-time in the white goods work alone, and that at wages from \$3.50 to \$4.50 a week, one can but question the cause and ask whether we do well to train the nimble fingers of our youth for this fierce battle. There is the greatest need of vocational guidance and that by means of a well-organized bureau with experienced and trained advisers. The misfits, more than the untrained, are among these idle workers. It is devoutly hoped that the standardization of housework, of homemaking, and of child care may win for them their proper place as a vocation for girls, many of whom are better fitted to be house workers than factory workers.

The following is the program for girls of the day classes :

FIRST YEAR

- I. Trade work in one trade 22-25 hrs. per week.
- II. Cookery, 2 lessons $1\frac{1}{2}$ hrs. each per week.
- III. Class instruction 3 to $4\frac{1}{2}$ hrs. weekly.
 1. Trade arithmetic (not given all year except to girls backward in arithmetic).
 2. English — oral and written.
 - a. Business letters.
 - b. Compositions based on trade work.
 3. Spelling — trade terms, phrases and words in common use.
 4. Writing.
 5. Citizenship — social ethics.

The above subjects are not necessarily presented parallel to each other. One subject, such as arithmetic, is presented for one term, as necessary, and another substituted as advisable.

IV. Art.

1. Color scales.
2. Line, such as arrangement of tucks, rows of insertion, etc.
3. Spacing and proportion of arrangement of trimmings, etc.
4. Designs for garments, trimmings, hats, etc.
- V. Physical education, 2 lessons of 45 min. each weekly.
 1. Short drills in marching, wand drills, etc., for coöperation.
 2. Games, such as tag, pass ball, volley ball, etc.
 3. Folk dancing.
 4. Hygiene.

SECOND YEAR

- I. Trade 22-25 hrs. per week.
- II. Advanced cooking (elective), 2 lesson of 1½ hrs. weekly.
- III. Class instruction 3-4½ hrs. weekly.
 1. Advanced trade arithmetic given for one term of fourteen weeks.
 - a. Shop organization.
 - b. Estimates of material for garments.
 - c. Economy of material.
 - d. Estimates for prices on single garments and large orders, such as underwear, etc.
 2. English.
 - a. Accurate descriptions of work, etc.
 - b. Directions for making garments or parts of garment.
 3. Textiles.
 - a. Study of weaves, textures, adulterations, etc., through practical tests.
 - b. Short history of common textiles — cotton, linen, wool, and silk.
 4. Industrial history and geography as related to women's work.
 5. Citizenship — practical civics.
 6. Apportionment of income — expenditure.
- IV. Art (elective).
 1. Applied design — designs for dress trimmings, hat trimmings, buckles, bands, etc.
 2. Costume designing.
 3. Designing of hats.
- V. Physical education.
 1. Continuation of first year's work.

The Girls' Technical High School. — The technical high school is of a widely differing type, having broad academic and general vocational courses extending over three or four years for those able to devote so much time to study and preparation for a life work. Since few girls who enter high school know what their future work is to be, the high school course, if constructed upon broad lines, will help determine for each girl to what she can best afford to devote herself as a means of livelihood. The program for the practical arts high school is outlined to include as many of the liberal or non-vocational

studies as possible, together with the necessary vocational studies. These are given with as broad an educational value as possible but must represent exact industrial conditions. By the third year the girl is expected to show her preference, and real specialization takes place in the senior year. In addition to the special line of work the girl is "given the English, mathematics, history, and science which will be most helpful in future competition."

The coöperative plan is followed in some cities with success, and an increasing number of opportunities to coöperate in office, shop, factory, and institution are being found.

GIRLS' PRACTICAL ARTS COÖPERATIVE COURSE

FIRST YEAR

English	4
Mathematics	4
Applied art	5
Cookery	4
Sewing	8

Music	1
Physical training	2

SECOND YEAR

English	4
Mathematics	5
Applied art	4
Cookery and home economics .	6
Millinery and dressmaking .	10

Music	1
Physical training	2

THIRD YEAR

English	4
French, German, or Spanish .	4
Applied art	4
Cookery	6
Millinery or dressmaking . .	10

Music	1
Physical training	2
Coöperative plan; alternate weeks in school and shop.	

FOURTH YEAR

English	4
French, German, or Spanish .	4
History (American).	4
Civics	1
Applied art	2
Cookery	6
Millinery or dressmaking . .	10

Music	1
Physical training	2
Coöperative plan; alternate weeks in school and shop.	

SOMERVILLE COURSE

FIRST YEAR

Required Studies

	PERIODS	POINTS
English	4	4
Mathematics	5	5
Ancient history	4	4
Science lectures	1	
Ethics	1	
Music	1	
Physical training	1	
Cooking, sewing, and drawing	10	5

SECOND YEAR

Required Studies

	PERIODS	POINTS
English 2	4	4
Ethics	1	
Music	1	
Physical training	1	

Elective Studies

Group I. (Choose two)

Geometry	5	5
European history	4	4
French	5	5
Household physics	5	5

Group II. (Choose one)

Drawing and applied arts	10	5
Cooking	10	5
Millinery and dress-making	10	5

THIRD YEAR

Required Studies

	PERIODS	POINTS
English 3	4	4
Physical geography	5	5

	PERIODS	POINTS
Ethics	I	
Music	I	
Physical training	I	

Elective Studies

Group I. (Choose one)

French 2	5	5
Practical arithmetic	5	5
Cooking and household chemistry	5	5

Group II. (Choose one)

Domestic arts	10	5
Drawing and applied arts 2	10	5

FOURTH YEAR

Required Studies

	PERIODS	POINTS
English 4	4	4
United States history and civics	4	4
Ethics	I	
Music	I	
Physical training	I	

Elective Studies

Group I. (Choose one)

French 3	4	4
Review of mathematics	5	5
Physics	5	5
Biology	5	5

Group II. (Choose one)

Dressmaking	10	5
Millinery	10	5
Household management	10	5

The Household Arts in the Academic High School. —

The program for household arts in the general academic high school course differs from that in the practical arts high school as the natural result of its differing aim. The girls following this course do not feel the economic pressure of

those entering the practical arts high school course, and may continue their studies into the college. Therefore this program must include college entrance requirements. Some colleges are granting from two to four credit units for household arts. These courses are given with a view to the girls' own needs and are made as broadly educational as possible. The experimental method in laboratory practice, and the broad economic and social content of household arts make it a subject as truly educative as any in the school program. Its value, like that of any study, lies largely in the way in which it is presented. It may also form a basis for later specialization during the college course and lead to several vocations, such as the teaching of household arts, institutional management, dietetics, nursing, social service, public health work, etc. The fortunate thing about a household arts course is its dual value, as a preparation for living as well as for earning a livelihood.

ACADEMIC PROGRAM INCLUDING HOUSEHOLD ARTS

FIRST YEAR		SECOND YEAR	
English	4	English	4
Elocution	1	Elocution	1
Latin or German (adv.) or Ger- man (beg.)	5	Latin or German (adv.) or Ger- man (beg.)	5
Algebra	4	Geometry	5
Garment making and laundry work	8	Millinery and dressmaking . .	8
Applied art	2	Applied art	2
Music	1	Music	1
Physical training	2	Physical training	2
THIRD YEAR		FOURTH YEAR	
English	4	English	4
Elocution	1	Elocution	1
One from Latin or German (adv.) or German (beg.) or German (1st year) }	5	Two from Latin or German (adv.) or German (beg.) or German (2d year) }	5

French	4	French	4
Spanish	4	Spanish	4
History (ancient)	4	Physics (2 lab.)	6
Botany	2	History (American)	4
Chemistry (2 lab.)	6		
Home economics	8	Civics	1
		Home economics	6
Applied art	2	Physiology	5
Music	1	Applied art	2
Physical training	2	Music	1
		Physical training	2

SOMERVILLE COURSE

FIRST YEAR

Required Studies

	PERIODS	POINTS
English	4	4
Mathematics	5	5
Science lectures	1	
Ethics	1	
Music	1	
Physical training	1	

Elective Studies

Cookery	5	2½
Choice of one language	5	5

SECOND YEAR

Required Studies

	PERIODS	POINTS
English 2	4	4
Ancient history	4	4
Ethics	1	
Music	1	
Physical training	1	

Elective Studies

Cookery	5	2½
Choice of one language	5	5

THIRD YEAR

<i>Required Studies</i>		PERIODS	POINTS
English		4	4
European and English history		4	4
Ethics		I	
Music		I	
Physical training		I	
<i>Elective Studies</i>			
Household arts		5	2½
Choice of one language		5	5

FOURTH YEAR

<i>Required Studies</i>			
English 4		4	4
United States history and civics		4	4
Ethics		I	
Music		I	
Physical training		I	
<i>Elective Studies</i>			
Household arts		5	2½
Choice of one language		5	5

HOUSEHOLD ARTS IN THE SCHOOLS OF THE UNITED STATES. — Legislation setting up systems of state aid for vocational education has been secured in several states and is under consideration in others. This legislation is concerned with the establishment of practical arts high schools in which shall be given instruction in household arts. The status in a few of the states which have most advanced legislation is as follows.

Massachusetts is one of the few to have adopted a state system of vocational education. The existing schemes differ principally in regard to the amount of support given and degree of control exercised by the state. Massachusetts provides for household arts, agriculture, and industrial training. Here,

as in Connecticut, New York, and Wisconsin, "the instruction given state grants must be open to pupils over fourteen years of age who are able to do the work successfully, even though they have not received a common school diploma. The effect of this is to set up a new kind of secondary school paralleling the regular high school for those over fourteen years of age." In Massachusetts the local community builds and equips the plant and the state pays one half operating expenses. Payment is in proportion to results accomplished. The State Board of Education is responsible for the administration of vocational education as well as for general education. The amendment to the act of 1911 raises to sixteen the compulsory school age for attendance on a vocational or continuation school by children regularly employed. Boston opens continuation schools September 1, 1914.

New York established a system of state-aided vocational schools to be administered by the State Board of Education, and those grants have been extended from day schools of various kinds giving training in home economics, agriculture, trades and industries to part-time, continuation, and evening schools, as well as increasing the aid to two thirds the salary of the first teacher and one third the salary of each additional teacher. This aid amounts to 28 per cent of the operating expenses of the school in the larger centers and 29 per cent of the schools in rural communities. A local option measure empowers local boards of education to extend the compulsory education law to "permit" children between the ages of fourteen and sixteen years of age to attend part-time and continuation schools. This new legislation substitutes day attendance of from four to eight hours a week for evening attendance. State aid to industrial schools for boys and girls between fourteen and sixteen is given where girls put in half the day in household arts work. In some of the schools the girls take a little of each subject for two years and in other schools a little of each for the first year and specialize in the second.

A department of homemaking in connection with a school of agriculture is state-aided, and the household arts work is given more time than in ordinary programs.

The last general legislature made available for Canning Club work in Tennessee about \$5000. It is necessary for the counties to raise at least \$200 and the state will then give \$100, the state giving one half as much as the county raises, up to \$500. The Canning Club work has encouraged interest in gardening and home work. Similar practices with regard to stimulating interest in household arts through Canning Clubs have been adopted in other southern states.

In **Ohio** any board of education may establish and maintain domestic science, manual training, and commercial departments, vocational and trade schools, also kindergartens, in connection with the public school systems, and pay the expenses of establishing and maintaining such schools from the public school funds as other expenses are paid. The state does not compel nor provide support for any of these subjects excepting agriculture, which is left optional for city districts. Ohio was the first state to enact a law compelling part-time schooling for those engaged in wage-earning occupations and requiring attendance of all under seventeen years of age who have not completed the fifth year of school. Any who have not completed the eighth year of school and are not regularly employed must attend regular school until they have either completed the eighth grade, secured employment, or reached the seventeenth year. Household arts is offered girls in regular and continuation schools in those cities that have, by referendum to the board of education of the community, established continuation and part-time classes. The recent school survey has awakened wide interest which will doubtless result in early legislation. The public school system of Cincinnati has taken advantage of the state right to establish vocational training departments, as have also the cities of Toledo, Cleveland, Columbus, and some others.

Iowa has no special legislation along the lines of vocational education, strictly speaking. They have some legislation relating to industrial work in the public schools, and the 34th general assembly passed a law, amended by the 35th general assembly, providing state supervision and state financial aid for a normal training course in the high schools. This course includes elementary pedagogy and art of teaching elementary agriculture and home economics. One hundred and twenty-nine of these high school normal training courses have been established under authority of this law. In each of these high school districts, domestic science is taught, and many other high schools not having the normal courses are teaching domestic science. The law provides an appropriation of \$100,000 for the first year and \$125,000 for each year thereafter. It also provides that the aid given each school shall be \$750 annually. So general and widespread has become the interest in this subject in Iowa that the last legislature passed a law making the teaching of agriculture and domestic science compulsory in all public schools of the state after July 1, 1915. Another law provides for state aid to consolidated schools, provided that there is the necessary department and equipment for teaching agriculture, home economics, and manual training, and employing teachers qualified to teach these subjects. Iowa shows a fine record: specially equipped trains which make tours of the state with short stops where brief lectures are given; extension work and short courses attended last year by 15,400 women regularly enrolled; Farmers' Institutes; health contests—all supported by the extension department of the state. A survey of the rural districts made under supervision of the child welfare department to secure vital statistics and complete information in regard to the health of children, the first of the kind ever undertaken in the United States, indicates the interest taken in the science of right living. "Home Economics in Iowa is not a mere question of cooking and sewing; it is demanding the best thought and highest culture in the

study and the solution of the most vital problems that concern the physical, mental, and moral development of our people and that make for a better civilization."

The **Indiana** legislature established, by means of the most comprehensive statute yet enacted, a state system of vocational education, giving state aid in domestic science, industries, and agriculture, through all-day, part-time, continuation, and evening schools. It provides that elementary domestic science be taught in all grades of city, town, and township schools and outlines the course of study, but provides no state aid for what it terms prevocational instruction to distinguish it from the work to be done in the special vocational departments or schools further provided for by the law. It also provides that the board of education shall outline a course of study in domestic science as well as agriculture and industrial work, which it may require high schools to offer as regular courses. The state regulates the qualifications of the teachers and provides aid in the maintenance of approved vocational schools or departments for domestic science, industries, and agriculture by payment annually of an amount equal to two thirds of the sum expended annually for instruction in these technical and vocational subjects. Schools, cities, and townships are reimbursed to the extent of one half the sum expended for tuition in approved vocational schools. The law requires each local community to erect and equip rooms or buildings in which to teach these vocational subjects and for use as social centers suitable for the legal voters of any township. A special tax of one cent is authorized, and any surplus not allotted to schools is to be placed in a permanent fund for the support and encouragement of vocational education.

In **Wisconsin** a recent law grants special aid to county schools of agriculture and domestic science equal to two thirds of the amount actually expended for maintaining such schools during the year, provided that the total amount shall not exceed \$6000 to any one school in one year when the

average daily attendance shall not be less than one hundred and twelve pupils, nor exceed the sum of \$8000 when the average attendance shall not exceed one hundred and eighty-seven pupils. Minimum wage for teachers of domestic science is established by the provision that state aid shall not be granted to any school where the salary paid to any teacher is less than \$60 per month. The act of 1912 extended aid from the treasury of the commonwealth to classes in household arts, approved by the board of education, for women, no matter what occupation they engage in during the day; whereas previously state aid for evening instruction was confined to those classes made up entirely of those who were employed during the daytime in occupations for which the work of the evening class gave more or less direct preparation.

Federal Subsidies. — Federal aid for vocational education is likely to be granted at an early date, providing for extension teaching and preparation of teachers for service in vocational schools giving instruction, through all-day, part-time, and continuation and evening classes, for the farm, the home, and the shop. The conditions surrounding the appropriation of moneys to the states is the only debatable question, and the working out of this problem as to the relationship of the national government to the states in the field of education is of interest to all.

TOPICS FOR FURTHER STUDY

1. What principles should control the organization of a course in household arts in secondary schools?
2. Would it be possible to relate the work more directly to both home and school life by the choice of problems?
3. Would you recommend a course of study being planned upon the basis of problems related to the girl, the environment, the locality, and other subjects in the school program, rather than upon topics?
4. What would you have our girls become at the end of their high school course?

5. Is the school contributing all it might to the production of this kind of young womanhood?
6. What have been the causes contributing to the changes in the character of home life?
7. What is feminism, and what its relation to instruction in the public schools?
8. What has necessitated the introduction of household arts into the schools?
9. Are you content to have this subject taught merely as sewing and cooking?
10. What vocational outlets are there for girls following this course?
11. What minimum of time for household arts recitations per week should be demanded?
12. How may the work be motivated?
13. What equipment does the work require?
14. If household arts in high schools is to emphasize the reasons for doing things, and is to be given largely from the point of view of applied science, how can the curriculum be arranged that the girl may have some science to apply?
15. Can a course in general science be given in the first year and the course in foods left until the second year?
16. Should class work in household arts which is purely manipulative be given high school credit? If so, in which course?
17. Should a high school offer elementary courses in cooking and sewing without credit, where such courses are not provided by the elementary schools?
18. How many units in household arts should be required?
19. Should there be a better standardization of teachers of household arts?
20. To what extent are textbooks advantageous in the teaching of this subject?
21. What is the standard in household arts as taught in England, Switzerland, and Germany compared with its standard in the United States?
22. Are the states doing as much for girls as for boys in specialized instruction?
23. What distinction is there between household arts taught in trade, practical arts, vocational, or technical schools and in a general high school course?
24. Localities have adopted various names for the subject here called household arts. The National Society has adopted the term home economics. Domestic science and domestic art are names used in

secondary schools; domestic economy is adopted by some. What name do you consider best, and why?

REFERENCES

- BEVIER, ISABEL, and USHER, SUSANNAH. *Home Economics Movement*. Boston, 1906.
- Conference of Association of Domestic Science Teachers. Liverpool, 1909.
- COOLEY, ANNA M. *Domestic Art in Woman's Education*. New York, 1911.
- England, Board of Education. *Regulations for the Training of Teachers of Domestic Subjects*, 1909. Circular 719. *Teaching of Needlework*, 1909.
- Regulations for Secondary Schools*, 1907, 1908, 1909.
- Special Reports on Educational Subjects*. Vol. I, 1896-1897, Domestic Economy Teaching; Vol. II, 1878, The Heuristic Method of Teaching or the Art of making Children discover Things for Themselves; Vol. VIII, 1902, Education in the Netherlands; Vol. XVI, 1896, School Training for the Home Duties of Women, Belgium, Sweden, Norway, Denmark, Switzerland, France; Vol. XIX, 1907, School Training for the Home Duties of Women (Germany and Austria).
- HODSON, F., editor. *Broad Lines in Science Teaching*. London, 1909.
- International Council of Women. *Health of the Nations*. Aberdeen, 1906.
- Ireland, Department of Agriculture and Technical Instruction. *Program for Day Secondary Schools*. 1908.
- Program of the Irish Training School of Domestic Economy*, 1909-1910.
- KINNE, HELEN. *Equipment for Domestic Science Teaching*. New York, 1909.
- Methods of Teaching Domestic Science*. New York, 1912.
- Lake Placid Reports on Home Economics*. Boston, 1899-1909.
- NORTON, A. P. *Teaching of Home Economics*. Boston, 1910.
- RAVENHILL, ALICE. Housecraft in Secondary Schools for Girls. *Education*, February 14, 21, 28, March 6, 13, 1908.
- Teaching of Domestic Science in the United States. In English Board of Education, *Special Reports*, Vol. XV. London, 1905.
- Report of Proceedings of Fourth International Congress on Technical Education (London, 1897), containing (1) *History of Training Schools for Teachers of Domestic Economy in England*; (2) *Treatment of Domestic Science as an Element in Girls' Education*; (3) *The Relation between General and Technical Education*; (4) *Technical Education*

in Secondary Schools; (5) *The Teaching of Domestic Economy in Girls' Secondary Schools*.

Report of the London County Council Conference of Teachers, 1910.

(1) *The Correlation between the Teaching of Domestic Economy and Experimental Science*; (2) *Practical Domestic Economy Teaching in a Secondary School*.

SMYTH, A. WATT. *Teaching of Domestic Subjects. Physical Deterioration*. London, 1904.

Women's Industrial Council, (1) *Technical Education for Girls in England and Elsewhere*, 1897. (2) *Domestic Science Teaching*, 1904. (3) *Technical Education for Women and Girls, at Home and Abroad*, 1904-1905.

WOOLMAN, M. S. *The Making of a Trade School*. Boston, 1910.

Sewing — A History of Education. Household Arts Review, February, 1910.

CHAPTER XVII

VOCATIONAL EDUCATION

SCOPE OF VOCATIONAL EDUCATION. — In a certain sense, all education is vocational in that it aims to prepare one for the more efficient and satisfactory performance of the activities of life. Even liberal education is in a sense vocational, for in its various forms it has aimed to prepare for the life or calling or "vocation" of a statesman or man of public affairs, of the gentleman, of an ecclesiastic, or whatever form the particular social concept of the liberally educated man may have taken. Even in the classical period, when the conception of liberal education was formed, it aimed to produce the philosopher in Greece, the orator in Rome, each defined as the man efficient in the application of his knowledge. In its earlier historic stages elementary education was always vocational, in that it was merely a preparatory stage to some form of higher education, whether the vocation to be followed was that of a scholar, an ecclesiastic, a gentleman, a tradesman, or a craftsman.

But in the ordinary usage of the term, vocational education is differentiated from the more general aspects of education, in that the chief concern of education in its vocational form is the training in the practical application of knowledge acquired in early stages of the educational process and the education of selected or differentiated groups. In this sense, vocational education includes all the various forms of higher or professional education, as that for the law, for medicine, for the Christian ministry, and for the various phases of engineering. So also agricultural education, commercial education, and allied subjects all represent phases of vocational

education, though frequently considered as professional education as distinguished from those vocations where the manual element is more prominent and the intellectual or scientific is more elementary in character. This last phase, the one generally indicated as vocational education, is termed industrial education.

The instruction of girls in general household activities under the name of household arts or economy is in a very broad sense vocational.

The prominence into which these various phases of vocational education have come of late is due to very profound social and economic changes which are taking place in modern society. Since these changes affect each special aspect of the subject, they are enumerated in the following discussion of industrial, commercial, agricultural education, and in the chapter on Household Arts. The general educational bearing of these fundamental changes is presented in the concluding chapter of this volume on the Reorganization of Secondary Education.

INDUSTRIAL EDUCATION

INDUSTRIAL EDUCATION. General Definition. — The term "industrial education" may be used in a very comprehensive sense or in a more restricted meaning. In a large way the term includes all education relating to the industries, and in this sense would include instruction in industrial arts in the elementary school, trade and technical instruction designed for the industrial worker, and the professional education of the engineering schools. In common usage, however, the term is employed in a more limited fashion as denoting the field of vocational education designed to meet the needs of the manual worker in the trades and industries, and in this sense it is used in this chapter. In this conception industrial education has to do with the secondary field, beyond the point at which boys and girls leave the elementary school and below the college.

Origin of the Present Problem. — The need for industrial education, as far as it is a matter of schools, has arisen since the industrial revolution of the eighteenth century, which introduced the factory system as the universal type of modern industrial organization. During the four or five centuries when the handicraft system of small masters and establishments was the prevailing basis of production, the matter of industrial training was met in a simple and, on the whole, a competent manner within the conduct and organization of trade procedure.

The effects of the factory system were: (1) that division of labor, constantly extended, no longer allowed the learner, if employed to the greatest economic advantage, to obtain a broad experience in all branches of a craft; and (2) that the entire relation between employer and learner was changed. The master craftsman, no longer taking direct part in the processes of production, became the capitalist employer, whose first concern is the development of highest immediate productive efficiency. The learner, on the other hand, entering into such an organization, faces, for the most part, a wage-earning career in which his place will be determined not alone by his abilities and ambitions, but by the particular opportunities afforded him for breadth of experience and for comprehension of these experiences. In such a situation it has ceased to be the immediate interest of the employer to bestow more attention upon the learner than will suffice to make him most rapidly into a productive unit at some process in the range of the establishment. Still less is there economic incentive for the wage-earning worker in a commercial establishment to give time and effort to extend the training of the learner. Productive efficiency is the sole aim of the modern organization of industry. For this purpose it is a highly adapted instrument, but education lies outside of this purpose. These latter considerations operate so powerfully upon the case that even in trades representing very little division of

labor, the value of apprenticeship training has often fallen to a very low point.

Factors in the Problem. — To sum up, in this connection, the situation presented by modern industrial conditions, the following facts should be noted. First, grades of skill and the extent to which division of labor is carried vary greatly in different industries. Second, the typical manufacturing industries employ a large number of workers of low-grade skill, who require little initial instruction or experience to adapt themselves to their narrow range of machine operations; and a smaller number of highly skilled workers demanding for their equipment breadth of experience and trained intelligence. Third, the economic interest of the employer is mainly concerned with the supply of the latter class of workers, and any measures undertaken by him to train such a class are necessarily based on the prospect of future return and not of immediate profit. Fourth, such training on the part of the employer involves labor in addition to the purely productive work of an industrial organization, and for that reason an additional element of expense. This element of expense and the extreme mobility of labor under modern conditions, permitting no guarantee to the employer that the learner will remain in his employ after receiving a training, constitute the chief obstacles to the development of adequate measures of industrial training within commercial establishments. To these obstacles is added the fact that, besides skill of hand, modern industry requires in its expert workers increasing knowledge of mathematics, science, drawing, and technical matters in order to insure proper comprehension of new methods and new forces; and for instruction in these branches the organization and personnel of an industrial establishment are not well adapted.

These conditions, under which modern industry finds the task of competently training high-grade workers within its own organization difficult, expensive, and not assuredly profitable,

have brought forward the demand for an outside agency, viz., the school, to assist in the task. The problem thus presented of supplying the deficiencies of training under commercial conditions, and of supplementing this training by additional instruction, is evidently one that must find its solution in particular and varied measures adapted to the needs prescribed by different localities and different industries. From the nature of the case there can be no general solution, but only a multitude of particular solutions.

The precise ends, then, placed before industrial education, looked at from this purely economic aspect, are to supply either breadth of practical experience along particular lines, or knowledge leading to the comprehension of technical practice, or both, to young people having opportunities or ambitions to fit themselves as high-grade workers.

European Experience. — To this problem the leading countries of western Europe have addressed themselves with increasing seriousness for something over half a century, and in the United States conviction as to its importance has been rapidly developing during the last few years. The particular ways in which European countries have approached the problem have been markedly differentiated by racial temperament, institutional development, and industrial conditions. Germany, with her policy of fostering the old trade guilds and their supervision of apprenticeship, has found her particular problem met to a large extent by specialized industrial continuation schools, at first conducted in the evening and now to an increasing extent in the day. These schools have devoted themselves almost wholly to supplementary technical instruction; but in the continuation schools of Munich, Dr. Kerschensteiner has introduced trade work both to broaden the commercial routine and to lend zest and point to the other instruction.

One of the chief reasons why the continuation schools fulfil such an important function in German life is the fact that apprenticeship is not only general, but is entered into at the

age of fourteen, at the time when youths leave the compulsory *Volksschule*. Another feature that distinguishes the German continuation schools, though shared to some extent with those of Austria and Switzerland, and which marks their seriousness of purpose, is that attendance upon them is generally compulsory until seventeen or eighteen years of age. In the cases where the continuation school classes have been brought into the day, employers are compelled by law to allow their apprentices time for attendance. Compulsory attendance upon the primary school is in this way immediately followed by the compulsory attendance at continuation schools of all boys, and sometimes girls, who do not attend higher schools.

United States. — In the United States the conditions which force attention to the problem of industrial education have only recently appeared. This country has lived over the long industrial history of western Europe in the brief span of little more than a century. Beginning with many of the activities of the hunting and fishing stage, as illustrated in the life of the pioneer and settler, eastern America passed in rapid succession through the agricultural or farming stage and the handicraft period, with its independent town economy, and reached in the closing years of the nineteenth century a highly developed national system marked by immense manufacturing growth.

Throughout this rapid evolution, almost to the present time, the great demand for intelligent labor, consequent upon the exploitation of the enormous natural resources of the country, has afforded countless opportunities for advancement to the individual workman gifted with superior wit and adaptability. Practical ingenuity and power of quick comprehension and adjustment have often under these conditions been of more importance in winning positions of leadership and mastery than highly trained skill and technical knowledge. When to this situation has been added an enormous current of immigration that has served to supply not only skilled work-

men, but a great army of unskilled and semi-skilled workers increasingly needed for manufacturing operations, it is apparent why for a generation of advanced industrial organization both the American employer and the native-born American workman have remained comparatively indifferent to the need of industrial education.

This period, however, has come nearly to an end, and the stress of international competition and lowered margins of profit make it more and more evident that American industrial development can be maintained only by recourse to old-world methods, and the adoption of comprehensive and effective measures that will insure a competent supply of highly expert workers. What has already been accomplished in the United States is largely the result of private enterprise and philanthropy. Until within a very few years, the public school system has given little or no attention to industrial education and has devoted its energies entirely to general and non-vocational instruction.

Evening Schools. — The first serious efforts to react upon the industrial situation were represented in the establishment of a number of important evening schools affording instruction in drawing, science, and mathematics. Cooper Union and the Mechanics Institute of New York, Franklin Union and the Spring Garden Institute of Philadelphia, the Ohio Mechanics Institute of Cincinnati, and the Virginia Mechanics Institute of Richmond were all founded or opened their classes about the middle of the nineteenth century. Such schools and many others, among which should be mentioned the evening classes of the Young Men's Christian Association, have accomplished an important work in supplying supplementary technical instruction to the ambitious young workingman in the larger cities. Even in this direction, however, which represents the simplest and least expensive approach to industrial education, the public schools have been slow to follow. Their concern has been almost entirely with general studies, and it

is only of late years that differentiated and specialized courses, related to industrial practice, have been introduced in the public schools of a few of the more important cities.

The early work of the evening industrial and technical schools consisted of various lines of drawing, to which were gradually added courses in science, mathematics, and technical subjects. Beginning about 1890, certain of these institutions established practical shop courses in a few of the high-grade mechanical trades, intended to broaden the experience obtained by the student during the day. In a few cases such classes have been incorporated in public evening schools, where they have sometimes performed a valuable practical service in advancing those employed at like occupations during the day, and sometimes have served merely to give a little tool dexterity to the amateur or the clerk.

Technical Schools. — The next important reaction of organized education upon the industrial situation was that which took place for the most part in the period of mining and railroad expansion following the Civil War, and which resulted in the establishment of many engineering schools or institutes of technology. The establishment of such schools was at first through private foundation, but the passage of the Morrill Act in 1862, by which large land grants were made to the states for the support of instruction in the agricultural and mechanical arts, resulted shortly in the inclusion of engineering departments in most of the western colleges and universities. The development of this type of institution has been widespread in the United States, and has produced an institution equal, and in some respects superior, to anything of its kind to be found abroad. The function of such schools is to produce engineering and technical experts, the men needed to design industrial constructions, to devise technical processes, and to superintend industrial production.

Manual Training. — The first serious agitation for the inclusion of industrial training in the public schools was not

for real vocational training, but for the inclusion of manual work in the general course of study as an element of culture and general efficiency. This is to be considered in a subsequent section of this chapter.

Trade Schools. — The first important attempt to deal with the problem of industrial training in day schools took the form of a trade school for the building trades. In 1881 the New York Trade School was founded by Richard T. Auchmuty. The founder was an architect by profession, and felt very keenly the small part played by American-trained mechanics in the various building trades. Convinced that the apprenticeship system in the building trades was no longer effective, and that modern conditions gave no hope of its revival, he turned to the plan of a trade school as the only solution of the problem. To meet the economic difficulties involved in attendance, the courses in the school are only four months in duration, and only young men between the ages of seventeen and twenty-four are admitted. The aim of the school is to give a knowledge of processes and a skill of hand sufficient for immediate practical usefulness, leaving speed and perfected skill to be developed in after experience.

The development of schools which aim to take the place of apprenticeship after this point, in whole or in part, was very gradual. In the first twenty years after the New York Trade School was founded, only two important institutions were added, viz. the Williamson Free School of Mechanical Trades near Philadelphia, and the Baron de Hirsch Trade School of New York. Since the year 1910 some ten or twelve institutions that may strictly be called trade schools have developed in different parts of the country under either public or private support, as well as a number of commercially conducted schools in the building and other trades. In 1907 the trade school entered upon the stage of public administration. In that year the already established Milwaukee School of Trades was taken over by the city under the terms of the industrial education

law passed by the Wisconsin legislature. Since that date public trade schools have been opened in Philadelphia, Pennsylvania; Portland, Oregon; Worcester, Massachusetts; and Indianapolis, Indiana.

Certain of these schools — the New York Trade School and the Baron de Hirsch School — represent the short-course type; the others offer courses of two or three years in which practical trade training is supplemented by instruction in drawing and technical practice, and in some cases by science and mathematics. Tuition in such schools is either free or on a nominal basis, a condition made possible either by large endowments or by public support. Such schools are still somewhat in the experimental stage. They labor under very severe economic difficulties, first among which is the problem of support presented to the student worker during the period of instruction. Training for the skilled trades in the United States is in common practice restricted to the period above sixteen years of age, and as the great bulk of the youth who will form the mechanics and industrial workers of the country must of necessity enter upon remunerative work at sixteen or shortly after, the sacrifices necessary to permit attendance at a trade school can be expected only from a comparative few. The second aspect of the economic problem in relation to such schools is found in the large expense of administration, instruction, materials, and physical maintenance in proportion to the number of students that can be instructed. Furthermore, it is only in a few high-grade trades, the full command of which involves extensive subject matter and breadth of experience, that trade-school training can claim sufficient advantages over training under commercial conditions to repay its expense. It is, consequently, only in cities representing exceptional concentration of such industries that trade schools can expect support, and it is not yet entirely clear whether the results obtained will prove proportionate to their expense.

In the earlier agitation for industrial training in the United States, the trade school occupied the forefront of discussion and was usually considered as the one institution needed to solve the entire problem, but as the great economic difficulties of attendance for youth and young men who are to become ordinary workmen have come to be better apprehended, it is seen that such institutions can, so far as numbers are concerned, fulfil only a very subordinate office. This office in the case of the long-course schools will probably be to train a comparatively small number of highly equipped workers in a few of the skilled trades.

Preparatory Trade Schools. — Conditions similar to those noted above in the case of England have recently brought forward in the Eastern states the type of school called a preparatory trade school or intermediate industrial school. The situation of the fourteen-year-old boy in the United States is more acute even than in England, inasmuch as the disinclination on the part of employers in the skilled trades and high-grade industries to employ youths below sixteen years of age is much more general. Since the report of the Massachusetts Commission on Industrial and Technical Education in 1906, which pointed out the large numbers of boys and girls in that state who leave school at fourteen before graduation from the elementary school, the demoralizing influences that surround them, and the lack of economic progress made by such children, interest in a type of industrial school that shall aim particularly at the ages from fourteen to sixteen has been steadily growing.

The first school of this type to be established was at Rochester, New York, in 1908. Since then a considerable number of schools providing practical work in one or more of the large trade groups, together with related instruction in drawing, elementary science, history, English, shop calculations, accounting, and business forms, have been organized in Massachusetts and the state of New York. Such schools aim to

give the advantage of some degree of industrial intelligence and some knowledge of shop methods and materials to the boy or girl of sixteen entering upon industrial employment, rather than to impart a trade training.

This type of school points to the facts that forces other than the purely economic enter into the movement for industrial education, and that responsibilities are involved in the conduct of such education beyond those of developing industrial efficiency. The causes that have brought into being the preparatory trade schools in the United States are not alone the economic advantage to the industries in preparing better material for entrance therein — an advantage that employers would be quick to perceive yet slow to bring about — but rather the recognition on the part of the public of a social obligation to better the opportunities for great numbers of young persons to enter upon more substantial careers. These schools also serve to illustrate the fact that any institution which enters upon the task of industrial education cannot escape the responsibility of advancing at the same time the training of its students in social and civic efficiency. It is very evident that, under any form of representative government, no school that does not attempt to instruct the individual in his relations to the state as well as to promote his economic efficiency can command public support or claim a large place in dealing with the education of youth.

Part-time and Coöperative Plan. — The two schools just described aim to prepare for entrance into the industries by training beginners, a task economically justifiable only when such training cannot be obtained under commercial conditions. Of late years new types of school — the part-time day school and the coöperative school — that aim to give instruction to the individual at the same time that he is gaining practical experience in the industry have assumed importance. Such schools do not attempt the entire task of training the learner at any period, but divide the work with organized industry,

leaving to industry the practical training, and providing in the school those elements that industry cannot readily supply. These schools, together with evening industrial schools and correspondence schools, bring formal instruction into essentially coöperative relations with industry, avoiding the large financial burden of practical trade training, with its many difficult problems, and undertaking only those lines of instruction with which the school is prepared to deal readily and effectively.

The important practical results of the German, and, in particular, the Munich, continuation schools, which have brought instruction into the period of the regular working day, have produced a growing conviction as to the importance of such schools in the development of industrial education in America. The more individualistic spirit under which industry is conducted in the United States, and the great variety of conditions represented, make progress toward such an arrangement necessarily a very gradual matter, and it will undoubtedly be a considerable time before manufacturers will reach any general agreement to allow learners in their establishments to attend industrial schools during the working hours. Nevertheless, the increasing discussion and study of this plan, and the recognition of its important advantages, indicate that its considerable extension may be expected in the near future. Such a plan is more rapidly applied in cities, where the concentration of a few high-grade industries gives a large number of apprentices and learners in particular lines. If such schools are to increase beyond the field of these few skilled trades, it is evident that the problems of instruction become complex and difficult. In the case of low-grade factory industries, where little opportunity for technical instruction is to be found in industrial content, school instruction must necessarily assume other directions and find its opportunity in increasing the social horizon or home-keeping usefulness of the pupil, or in aiding to develop capacity for change of occupation. It is evident that the beginnings of such schools as are

represented at Cincinnati and Worcester, Massachusetts, must of necessity be upon a voluntary attendance basis, and many years must obviously elapse before public opinion in the United States reaches the point of authorizing compulsory attendance for a term of years, as is the case in southern Germany.

The coöperative plan by which the students spend half their time at work in industrial establishments and half in school, and which was first developed in the Engineering Department of the University of Cincinnati, has lately been applied to students of high school grade. This plan differs from the part-time plan in some important respects. In the first place the student body consists of enrolled high school students and not of apprentices already employed in commercial establishments. This fact insures a higher grade of academic preparation than is generally the case with apprentices, and the larger amount of time spent in school allows the general education to be carried much further. Encouraging beginnings have been made with this type of school at Fitchburg, Massachusetts, and Cincinnati, Ohio; but it is too early to define its future place. Whether, on the one hand, any considerable number of those aiming at and fitted for regular mechanic's work in the trades will be drawn to such schools, or whether, on the other hand, the schools will develop capacity for training leaders of the foreman and expert type, remains to be seen.

In this same group of supplementary or coöperating schools might be included the correspondence schools, which enroll a great number of young men engaged in industrial employment in the United States, and afford instruction by mail in a large number of technical subjects.

Apprenticeship and Corporation Schools. — The apprenticeship or corporation school, which has been developed in several industrial corporations of large size in the United States, is in a sense a part-time school in which both instruction and practical training are given within the commercial

establishment. Such a plan, which allows a maximum coördination of all lines of instruction, will probably be increasingly adopted in the case of railroads and other large corporations dealing with high-grade workers; but for the great majority of industrial establishments such a system is hardly practicable, and division of labor between the employer on the one hand and the public school on the other is the method making for greatest efficiency and economy.

Secondary Technical Schools. — The middle technical schools of Germany have no exact counterpart in the United States, but the several schools for the textile industry correspond closely to this type. Most prominent among these institutions are the Textile School of the Pennsylvania Museum at Philadelphia, established 1884 and noted for the high grade of its instruction, three state-aided schools in Massachusetts, at Lowell, New Bedford, and Fall River, and the Textile Department of the Georgia School of Technology at Atlanta. None of these schools requires previous practical training in the textile industry for admission, but in each school there are a number of mature students with such experience, and the character of the work approximates closely to that of the German schools.

Of late years other technical schools or classes of secondary rank have appeared, such as the day courses in machine design and applied electricity of Pratt Institute, Brooklyn, the Technological High School of the Ohio Mechanics Institute at Cincinnati, and certain courses in the Drexel Institute, Philadelphia, and in the Lewis Institute of Chicago.

Technical High Schools. — The question whether technical high schools with the same requirements of admission as regular public secondary schools can be incorporated into the American public school system has received considerable discussion of late years. The manual training schools, as above noted, do not contribute trained workers to the in-

dustries, and strong arguments have been made toward the conversion of these schools into technical high schools, having the distinct purpose of preparing pupils for industrial leadership; that is, for positions in industrial life requiring skill and technical knowledge, and of greater importance and responsibility than those of skilled mechanics. The serious question facing such a proposition is whether such results can be secured from a type of school that does not require practical experience before entrance, as in the case of the German technical schools, or provide parallel experience, as in the case of the coöperative schools.

Legislation. — Laws have been passed in a number of states providing for state supervision of industrial education and in several cases for the establishment and assistance of industrial and trade schools. Massachusetts was the first to act in this direction. In 1906 a State Commission on Industrial Education was created, with power to superintend the establishment and maintenance of industrial schools for boys and girls. The act further provided for the reimbursement to cities and towns of a part of the amount expended for the support of such schools. After two years of trial, the plan of an independent commission was found to be unsatisfactory, and the administration of the law was vested in the reorganized State Board of Education, with provision for a special commissioner to deal with the field of industrial education. Since the reorganization the state board has accomplished very important work in standardizing, as to scope, courses of study, and methods of instruction, the various types of schools that come under its control, as well as in furthering the establishment of a considerable number of schools.

New York State enacted a law in 1909 authorizing the establishment of general industrial schools, trade schools, and schools of agriculture, mechanical arts, and home making, and providing for the award to such schools of a certain measure of state support. The disbursement of state moneys to the

schools is by the terms of the act placed in the hands of the State Board of Education and made dependent upon its approval of the courses of study maintained. The establishment and conduct of these schools is referred to the local boards of education, but the appointment of advisory boards representing the local trades, industries, and occupations is made compulsory. The duties of such advisory boards are to counsel with and advise the boards of education in regard to the establishment and conduct of the schools.

In 1907 a law was passed in the state of Wisconsin empowering cities or school districts to establish, conduct, and maintain schools for the purpose of giving practical instruction in the useful trades, and placing such schools under the supervision and control of the local school boards. Permission was given to the school boards to appoint advisory committees to assist in the administration of the trade schools, and provision was made for the levy of a special local tax for the establishment and maintenance of such schools. The law was amended in 1909, and the minimum age of entrance to a trade school reduced from sixteen years to fourteen years for both young men and young women. In 1911 the state passed a number of acts relating to industrial education, which among other measures provide: (1) for a modification of the apprenticeship laws of the state by which apprentices shall receive instruction for not less than five hours a week; (2) that whenever any evening school, continuation classes, industrial school, or commercial school shall be established for minors between the ages of fourteen and sixteen, working under permit provided by law, every such child shall attend such school not less than five hours per week for six months in each year, and every employer shall allow all minor employees over fourteen and under sixteen years of age a corresponding reduction in hours of work; (3) that employers shall allow a reduction in hours of work at the time when the classes are held whenever the working time and that of the class coincide; (4) that a state

board of education be appointed to control the distribution of state moneys under the act.

Other states have recognized industrial education through legislative measures to the extent of providing official machinery for the development and supervision of such work, and in still other states investigating commissions have been appointed with the object of ultimate legislation in this direction.

MANUAL TRAINING. — In spite of many objections, the term “ manual training ” has come to be generally applied to all forms of constructive handwork when used as an agent in general education. When used in the broadest sense, instruction in domestic art and science, and constructive work in various materials in the lower grades are included. In a narrower conception, the term is restricted to work with mechanical tools given to boys. The tendency in American usage is to distinguish sharply between manual training as a feature of general education and specialized tool instruction given to selected groups for purely vocational ends.

Educational Value. Underlying Theory. — In the early agitation for the introduction of manual training in the eighties, the claims put forward for the new subject were in the main based on the conception of formal discipline. Manual training was entitled to a place in the school because it exercised the observation, trained the reasoning powers, and strengthened the will. Although it is doubtless true that public support of the new movement was due to a vague but sincere conviction that the introduction of handwork stood for industrial training, educators as a rule most carefully refrained from advancing a claim for utilitarian value in the work, and all utterances were for the most part expressed strictly in terms of the prevailing faculty psychology.

The early practice of manual training in the elementary school was experimental and formal. The type exercise was the universal form in which handwork appeared, and it was not until the influence emanating from the Sloyd School of

Boston (established in 1888) began to be felt that toolwork for boys assumed a more invigorating form. The fundamental principle of sloyd, which places emphasis on the value of working for a useful end, and so enlisting the interest of the worker, soon found acceptance in the general practice in the elementary school, and to a certain extent modified the methods of the manual training high school.

About the same period, the doctrine of formal discipline began to lose its place as the corner stone of manual training philosophy. By the beginning of the present century the conviction had developed that constructive work comes into natural relations with the worker only when he contributes something of his own thought to attain the end placed before him. Out of this attitude, aided by a deeper study of the thought of such educational leaders as Froebel, Pestalozzi, and Herbart, and clarified by the emphasis of the psychologists on the unity of the mental processes, has developed the conception of manual training as a means of expression — a means of expression in terms of form, color, materials, muscular activity, and concrete ends—a means of expression peculiarly adapted to child life.

During the last seven or eight years the growing emphasis placed upon the social meaning of education has caused attention to be turned more and more to the subject matter or content side of manual training, and the conception of manual training, at least in the elementary school, has come more and more to be that of an educational instrument interpreting the fields of art and industry in terms adapted to child life and the limitations of the school.

All of this development in the philosophy of manual training has tended away from the employment of self-contained, formal courses towards the use of handwork as a medium of social experiences leading to the acquisition of knowledge. One of the most complete expressions of this idea is the employment of constructive activities in the lower grades in the form

of social occupations, which serve as centers for instruction in other branches. This type of work was developed to a notable extent in the University Elementary School conducted by Professor John Dewey from 1896 to 1905 in connection with the University of Chicago.

Content of Course. — The early work in manual training in the elementary school was almost uniformly limited to the two or three upper grades, and consisted of shopwork for boys and sewing and cooking for girls. From these grades handwork slowly made its way downward, and at the present time such work, dealing with a variety of materials, is given in all grades in many of the larger cities. The report of the Commissioner of Education for 1910 states that in more than seven hundred cities of the United States, public schools have manual training in several years of the course, generally in the elementary grades, but frequently in all the years from kindergarten through the high school.

Place of Manual Training in the Various National Systems. — Manual training was first recognized as a valuable feature of school work in European countries. As early as 1858 Otto Cygnæus, who later organized the public schools of Finland on a modern basis, outlined a plan of handwork for the primary schools of that country, and in 1866 some form of manual work was made compulsory in all primary schools for boys in country districts as well as in the training colleges for male teachers.

In the United States, manual training came into being partly as the expression of a new educational philosophy and partly from dissatisfaction on the part of the public with the results of the purely bookish curriculum of the schools. The first appearance of constructive work for clearly definite cultural purposes appears to have been in connection with the classes of the Workingmen's School founded in 1878 by the Ethical Culture Society of New York. In 1880, through the efforts of Dr. Calvin A. Woodward, the St. Louis Manual

Training School was opened in connection with Washington University. This school was a completely equipped high school, giving instruction in various lines of shopwork and in mechanical drafting, as well as in the regular secondary school subjects with exception of the classics. The work of this school attracted wide attention, and the success with which mechanic arts instruction had been incorporated in the curriculum led to the rapid organization of similar schools in other large cities. In Chicago, Toledo, Cleveland, and Cincinnati privately supported schools were organized from 1884 to 1886, and public manual training schools were established in Baltimore in 1884, Philadelphia, 1885, and Omaha, 1886. The first provision for girls' work in these schools was made in the case of the Toledo Manual Training School, and included sewing, dressmaking, millinery, and cooking. The shopwork instruction given in these institutions comprised joinery, turning, pattern making, forging, and machine work, and sometimes foundry practice and tinsmithing. The character of this work has been very similar in different schools, and until late years has been almost uniformly based upon the principles of the "Russian System," so called because the ideas involved first gained recognition in the United States through the exhibit of the Imperial Technical School of St. Petersburg at the Centennial Exhibition in 1876. The central idea of this system of shopwork instruction, which was developed in a technical school for the instruction of engineers, is the analysis of a craft into its fundamental processes and typical constructions, and the presentation of these elements in an orderly and sequential scheme as separate exercises.

The rapid development of this type of secondary school, which has continued steadily since its inception, has resulted in an institution peculiarly American. In other countries the introduction and spread of manual training has been confined to the elementary school, and no institution of a purely educational character exists in Europe that represents any

parallel to the comprehensive and costly equipment of these schools, nor, it should be said, to their rather vague and indefinite educational status. Established with the double purpose of affording a more liberal and realistic training for boys of secondary school age, and of developing capacities for industrial careers, the records show that apart from the large number that go forward into engineering schools, only a trivial percentage of graduates from manual training high schools enter directly into industrial work, and that this small number go almost wholly into the "white shirt" occupations of draftsman or administrative assistant. Of late years a tendency has become apparent to intensify the industrial side of the curriculum in such schools, and to transform them into technical schools with a definite vocational basis.

Industrial Education and Manual Training. — With the attention given to industrial education in the United States of late years, manual training has undoubtedly lost something of its importance in the public mind. It is probable, however, that this attitude is only temporary; for all thoughtful consideration agrees that manual training in elementary schools constitutes an invaluable basis and, under the peculiarly unsettling influences of American life, a most necessary foundation for an effective system of industrial education. On the other hand, it seems probable, from many experiments now being conducted, that a semivocational or a prevocational type of manual training is likely to assume importance in large cities, which will afford to boys and girls, compelled to leave school at the compulsory age limit, an elective opportunity for one or two years before that time to acquire some measure of industrial intelligence and to learn from a number of industrial experiences the general field for which they may be best fitted. Recent development has all been along the latter line, though no one type of school has demonstrated its superiority.

COMMERCIAL EDUCATION

ORIGIN AND NEED OF COMMERCIAL EDUCATION. — Commercial education is now generally understood to include all education which prepares specifically for business careers. It is no longer limited to the narrowly technical or practical training which fits the student to perform the various operations that are necessary in the exchange of commodities, but it is generally taken to exclude the training that prepares for the work of production. With the practical training there is usually associated a certain amount of the liberal, or cultural, element of education. The proportion of this element differs widely in the almost innumerable forms of commercial education found in the United States and in foreign countries. In some it is practically nil; in others, it comprises over nine tenths of the whole amount of time given to study.

Recognition of this branch of education has been somewhat tardy, and can hardly be said to be complete even now. One reason for this is obviously the fact that a century ago the transaction of business was a simple matter compared with the complexity of our present organization. Commercial life itself was not very highly developed, and was, indeed, considered too humble a form of activity for the exercise of great talents, or for any special preparation. All this has been changed now. Commerce has so extended its sphere and has so developed its organism that it has become a field for the greatest intellects. Thorough preparation for it has become recognized as necessary, though there are still great divergences of opinion as to the form this preparation should take. Until recently it was not thought to be a function of either public or private schools — not a function of education, in the sense the word was used. For that matter, the very combination of the words “commercial education” is somewhat anomalous. Opposition to the conjunction came from both ele-

ments. The ideals of education and of business were regarded as directly opposed. The earnestness with which educators opposed the introduction of the commercial aim, or commercialism, into their methods is only paralleled by the cordiality with which the majority of business men condemned the aims and methods of education as impractical and useless for their purposes. Within the past quarter century utterances by each party to the detriment of the other have been frequent, but they are nearly absent now.

Recognition of commercial education has come, and the two warring elements have been partially reconciled. That they have been brought to realize the essential unity of their interests and their mutual helpfulness is not the least important advance made by education in the past quarter century. For, although the recognition of commercial education has been tardy, and although it is still in an experimental stage, its growth has been rapid enough to leave no doubt of its usefulness. If the figures were not in themselves sufficient proof of the fact that commercial education has grown in response to a real need and a real demand, it would only be necessary to examine its early history both in this country and abroad.

COMMERCIAL EDUCATION IN THE PUBLIC HIGH SCHOOL. — Commercial education in the public schools is still in the experimental stage. It has never been conspicuously successful, nor has it until recently been of a kind that promised much advance on the private commercial schools. It has made its way with difficulty, and there is still a good deal of suspicion and some antagonism directed against it. In its history, the weakness of our public educational system is made apparent. In the first place, our educational system has nothing of the compactness and unity of those of many foreign countries, notably Germany. Control is so largely local that there is difficulty in instituting a new movement with any degree of unanimity. Much time and energy are wasted by the several states and cities in making experiments, and much

more time is lost in waiting for others to make the experiments. It was with difficulty that even such so-called "innovations" as music, drawing, and physical training obtained recognition as desirable factors in public school education. In a similar way, the introduction of commercial studies was retarded by the lack of any unified system and the general conservatism of educators. Another objection was that there was no place for it. In the primary schools it was of course out of the question. The secondary or high schools were generally regarded as stepping stones to college and were dominated by the classical element. Certainly commercial studies were not academic. And although only a small part of the students in the high schools went to college it was felt that even those who did not should be given a substitute in the way of culture, so far as possible. There was no room for practical or vocational instruction. Nor were there any properly equipped teachers.

But the demand became too insistent to be unheeded. Many students left the public high schools early in their course to enter the private business schools, where they might obtain preparation for their future careers. Naturally there was some murmuring on the part of taxpayers, who felt that the public schools they paid for should give the education for which their sons and daughters asked, whether it looked toward a professional or a business career. Scientific courses were given in most of the larger high schools—why not commercial? In response to the demand, short commercial courses, of two years (and sometimes of only one), were offered in many high schools before 1890. The movement rapidly extended throughout the country. In 1893 there were 15,220 students in the United States in these courses; in 1895, there were 30,330. In the years 1893-1899 their numbers increased, while the enrollment of the private business schools decreased. This might seem to indicate that the courses were successful and were a good substitute for the private commercial school

courses. Such was far from being the case. The majority of them were poor; some were bad. They had come because the demand was too strong to be resisted, but they had little encouragement from above. The public educational system had simply accepted them as a necessary evil, and had slavishly imitated the private schools. The methods and the quality of instruction were inferior. There was little attempt to relate the cultural to the practical studies. A few new and alien branches had been grafted on an old tree, but they were poorly nourished by it and did not grow. The short commercial course in high schools was distinctly not a success, and began to fall into disrepute. The work of its graduates was compared unfavorably with that of regular four-year students. The private schools improved to meet the new competition, and far outstripped the public school courses, hampered as these were by all manner of difficulties. This is seen in the statistics of attendance. As has been said, the number of students pursuing commercial courses in the public high schools increased in 1893-1898, while that in the private commercial schools decreased. In the next five-year period, 1898-1903, both increased at about equal rates. In 1903-1908 the public high school enrollment in commercial courses seems actually to have decreased, while that of the private commercial schools increased. Doubtless the decrease was not so great as the government statistics make it appear, because of a change in the method of reporting. Indeed, the average number of students in the well-established commercial courses in public high schools has shown a fairly steady increase every year. For all that, the public school has not been a successful competitor of the private school in the latter's own field of short courses and purely technical training.

Within recent years, however, a movement has begun which promises to place commercial education upon a stable basis in our public school system. In many of the larger cities of the country since 1900 separate high schools of commerce

have been established. As early as 1892, far-sighted educators saw the necessity of this, if commercial education were to be successfully undertaken. In that year Professor Edmund J. James, then of the Wharton School in the University of Pennsylvania, in a notable address before the convention of the American Bankers' Association at Saratoga, made a plea for the establishment of separate commercial high schools. Interest in the proposition grew, and although it was some time before results showed, there was a general tendency to lengthen and broaden the commercial courses then given in the public high schools. In 1898 the Central High School of Philadelphia founded a separate commercial school with an entirely distinct curriculum. Soon after, the High School of Commerce in New York was opened. Others followed in Pittsburgh, Chicago, Brooklyn, Washington, and other cities. In the majority of these, the courses given were not materially different from those of the ordinary high school, except that the classical studies were generally omitted, and commercial branches were taught. They had the advantage of segregating students of common aim and of affording superior facilities for work. The length of the course was ordinarily four years, instead of three, two, or one, as in the commercial course of the ordinary high school. Beyond these, there were no very great advances in them. They were better, but not essentially different from the earlier type. But in a few cities, notably Philadelphia and New York, a different plan was put in operation. There was some attempt to look behind the demand for commercial education, to find the real need, and to fill it. It was a problem to be solved, and the school set itself to the task of solving it. If a business career was to be the goal, then all preparation should have that in mind. The whole course of study had to be reconstructed and made to serve an entirely different function from that of the classical high school. Not merely the commercial branches proper, but all the studies in the curriculum, should be adapted to

business needs. This was the solution proposed. The development of the plan has been slow, partly because of the need of much experiment, partly because of the dearth of suitable teachers. It was not an easy task to change pedagogical methods to fit the new ideal. Some help was obtained from the study of German and other foreign commercial schools. The experimenting is still going on and much remains to be done. There has been little outward change in the curricula of these schools recently, but inwardly there has been great development. For instance, in the foreign languages, a fair ability in speaking is regarded as more important than reading. In biology, chemistry, and the like, the commercial importance is demonstrated. Throughout the list, the practical application of knowledge is made and new relations between the studies shown. The whole scheme is becoming a unit, rather than a mixture of conflicting elements. There are only a few high schools of this type in the country now, but two recently established high schools of commerce — that of Boston and that of Cleveland — are based upon this new idea of commercial education. Many of the older ones are gradually tending toward it. It is beginning to be realized by educators that, if vocational instruction is to be given by the public schools, it should be given whole-heartedly, and not in a grudging acquiescence to a demand. It should prepare a student not merely to accomplish certain set tasks, but to grapple with new problems.]

The five-year course of study of the High School of Commerce of New York City is as follows :

FIRST YEAR. — Required : English (4) ; German, French, or Spanish (4) ; algebra (4) ; biology (with especial reference to materials of commerce) (4) ; business knowledge and practice¹ (6) ; drawing (second half year) (1) ; physical training² (2) ; music (1) ; Total, 26 periods.

¹ Including local industries and government of the City of New York (2) ; business writing (2) ; business arithmetic, business forms and methods (2).

² Including Physiology.

SECOND YEAR. — Required: English (3); German, French, or Spanish (4); plane geometry (3); chemistry (with especial reference to materials of commerce) (4); history¹ (with especial reference to economic history and geography) (3); stenography (3); drawing and art study (2); physical training (2); Total, 24 periods.

Electives: German, French, or Spanish (4); bookkeeping and business forms (3); business arithmetic (1); commercial geography (1).

THIRD YEAR. — Required: English (3); German, French, or Spanish (4); geometry and algebra² (3); physics (5); history³ (with especial reference to materials of commerce) (3); physical training (2); drawing and art study (1); Total, 21 periods.

Electives: German, French, or Spanish (4); bookkeeping and business arithmetic (3); stenography and typewriting (3); drawing and art study (2); commercial geography (1).

FOURTH YEAR. — Required: English (3); German, French, or Spanish (4); economics and economic geography (4); history of the United States (with especial reference to industrial and constitutional aspects) (4); physical training (2); Total, 17 periods.

Electives: A foreign language (4); advanced chemistry (4); economic biology (4); trigonometry and solid geometry (4); elementary law and commercial law⁴ (4); advanced bookkeeping, business correspondence, and office practice (4); stenography and typewriting (4); drawing and art study (4); modern industrialism (1).

FIFTH YEAR. — Required: English (3); logic, inductive and deductive (3); physical training (2); Total, 8 periods.

¹ First half year, Beginnings of Nations to 1300 A.D. Second half year, Modern History to 1750.

² In the second half year, students may elect additional stenography and typewriting or bookkeeping in place of the second course in mathematics, or may give double time to mathematics by omitting either stenography or bookkeeping.

³ First half year, English and colonial history, 1620 to 1750. Second half year, modern history (England and the Continent), 1750 to present time.

⁴ Students who do not elect law in the fourth year may receive instruction in commercial law in connection with advanced bookkeeping.

Electives: A foreign language (4); advanced mathematics (4); advanced physics (4); industrial chemistry (4); economic geography (4); nineteenth century history, Europe and Orient, diplomatic history, United States and modern Europe (4); banking and finance, transportation and communication (4); administrative law and international law (4); accounting and auditing (4); business organization and management (4); drawing (4); advanced economics (3).

It is too early to obtain more than a glimpse of the results of the new type of commercial secondary school. Undoubtedly it is an advance over the earlier. The instruction given is practical, but it is said that the cultural value of education is by no means lost. It is certain that there is a well-considered and intelligent purpose to meet the real needs of a large body of students for whom the classical high school offers no attractions. Some high schools go so far even as to plan their courses to meet the needs not only of those who will remain until graduation, but also of those who will leave after a year or two. High schools of commerce that are working along these lines report that they have a large proportion of students who would not enter any other school, or would not stay for any length of time. The graduates find it easy to obtain positions in business life. In purely mechanical lines they are not so well prepared as those of the private commercial schools, but in capacity to acquire new knowledge and ability to use it they are far superior. Many of them, indeed, find the first-year work of excellent university schools of commerce almost elementary for them. This is merely because such schools are so few in number that the university schools have not been thoroughly correlated with them. They suffer from the general lack of unity in our education plan, which makes it difficult for the student to gain a coherent, consistent education from beginning to end, other than that which prepares for one of the well-recognized professions, such as law, medicine, teaching, and the like.

A similar difficulty under which they labor is the dearth of well-trained teachers. These the university schools are beginning to supply. A beginning at least has been made, and it is not too much to expect that within the next decade the commercial secondary school will have become a very important part of our public school system, with a clearly defined relation to the other parts. More than that, it is probable that vocational schools of other types will have gained a firm footing, as they even now promise to do, under the leadership of the commercial high school. Many cities even now have vocational high schools of several distinct types.

AGRICULTURAL EDUCATION

DEVELOPMENT OF THE INTEREST IN AGRICULTURAL EDUCATION.—While the art of agriculture has been of popular interest and of practical necessity since the earliest periods, the academic study of the sciences underlying the art and of its practical processes are of very recent development. In the late eighteenth and early nineteenth centuries great popular interest in agriculture arose, partly as a result of the social and political changes of the times, partly as an accompaniment of the industrial and economic changes incident to the industrial revolution. In the United States one result was the formation of many agricultural societies. Such societies became centers of agitation for the promotion of agricultural schools. A few such schools were actually founded, one in Maine in 1821 and one in Connecticut in 1824. The development of the agricultural interest of the South, and the opening of the Middle West transferred the agricultural interests to those sections. This was followed, especially in the Middle West, by a similar development of agricultural societies and agitation for the formation of agricultural colleges. Two such, Pennsylvania and Michigan, were founded before the Civil War. This movement coalescing

with the one for industrial education resulted in the Land Grant Colleges established by the first Morrill Act of 1862.

The distraction of interest and the unsettling of all such efforts consequent upon the Civil War, together with the great industrial revival following the war, and the opening up of the almost unlimited resources of the great West again withdrew most interest from the problems of agricultural education. In the last decade of the nineteenth century and the early years of the twentieth century other conditions are forcing this question again to the front and are making of it an educational problem of national, even of world-wide importance. Among such conditions are the expansion of the public domain, the great rise in prices, especially of agricultural products, the decrease or cessation of the export surplus in the agricultural crops of the United States, the fertility exhaustion of farm lands, the relative decrease in agricultural population, and the general recognition that the existing institutions of agricultural education were not meeting the problem. On the other hand, advancement in the field of applied science has demonstrated vast possibilities in the application of science to the problems of agriculture. All of these have done much to bring the question of agricultural education again into great prominence.

AGRICULTURAL INSTRUCTION IN THE SCHOOLS.—

The agricultural colleges have done much, during the past forty years, to prepare the way for an extension of agricultural instruction and to stimulate an interest in the subject. The very important work which they have done in laying a foundation of sound agricultural knowledge was a necessary prerequisite to any general movement for the extension downward of agricultural instruction. Knowledge had to be accumulated, extended, and popularized before agricultural instruction below the colleges could become possible. The recent activity of the United States Department of Agriculture in stimulating and encouraging the many efforts looking toward the extension

of agricultural knowledge and agricultural instruction have been of great service. The movement has also been greatly aided by the knowledge, which has come to us within recent years, of what European states and nations have been and are doing in agricultural instruction, and the success which has attended their efforts. The work of France in particular has been an inspiration to us. Another influence which has greatly aided the movement has been the growing realization that this nation must, ultimately, be a great agricultural nation, and that our present wasteful and unintelligent methods of agriculture will not do for the future. To find a means of disseminating proper ideas as to how best to conserve and to improve our great national resource has been a strong motive underlying the movement.

Certain movements within the schools themselves have fitted in with and helped to prepare the way for the development of agricultural instruction. The general introduction of nature study into our schools, which came with the popularization of science, has been of very material value in preparing the way and in developing teachers capable of taking up the agricultural work. The still more recent school garden movement, and the general demand for more practical instruction in the public schools, both elementary and secondary, have also contributed their share in preparing the way for the somewhat general introduction of agricultural instruction. As the movement has grown in importance and definiteness, the far-reaching results, both economic and educational, have come more clearly into view, and the movement in turn has begun materially to change our conceptions of the methods of procedure, purposes, and needs of the rural school and of the high school in particular, and bids fair to modify for good our whole educational work.

Agricultural High Schools. — Schools of secondary grade for theoretical and practical training in agriculture exist in France, Germany, Austria, Sweden, and Japan. The *écoles*

pratiques of France, first established in 1875, of which there are now about 50 in existence, are in reality secondary schools for the training in agriculture of the sons of peasant proprietors or small farmers, and with a two-year course of instruction. In Germany many agricultural schools have been established, beginning at the close of the *Realschulen* course, or at the end of *unter-sekunda* of the *Gymnasia* or *Realgymnasia*, in which natural sciences and agriculture take the place of the languages and mathematics of the gymnasial course. In Japan any city, town, or village may establish a secondary school, if the local finances will permit of so doing without detriment to the elementary schools of the place. By 1904 there were 57 such schools in Japan, and the number is increasing every year.

It was thirty years after the establishment of agricultural colleges in this country before the first successful agricultural high school was established. This one, established in 1888, was in connection with the University of Minnesota, and its success was pronounced from the first. By 1898, however, the number of agricultural high schools had only increased to 10, and the teaching of agriculture in the normal schools and the elementary schools of the country had only begun. Since then the development of secondary instruction in agriculture has been much more rapid, though the development has not been so fast as in the case of agricultural instruction in the elementary schools.

To provide instruction in agriculture in the high schools is a very much easier problem than to provide such instruction for elementary schools. The age and mental capacity of the pupils, the nature of the school, and the character of its work and equipment, all tend toward a specialization in subject matter, and specialized agricultural subjects are much better organized and are easier to teach than the more generalized work of the elementary school. The equipment needed, on the other hand, is more extensive, few good textbooks of

secondary grade have as yet been provided, just what is to be taught has not as yet been definitely decided upon and put into practice, and the number of properly equipped teachers is relatively small, and probably will continue to be much less than the demand for some time to come.

Statistics collected in May, 1909, showed that the number of agricultural high schools, or colleges offering definite secondary agricultural courses, had increased to 60; that 346 public high schools were teaching agriculture as a part of the high school course; that 119 state and county normal schools and 16 agricultural colleges were training teachers to teach agriculture in the schools; that a number of private secondary schools were aiding in the work; and that 16 institutions offered correspondence or reading courses of secondary grade. In all about 500 institutions were giving secondary instruction in agriculture in May, 1909, and the number has materially increased since then. Some instruction in agriculture is now being added to secondary school courses so fast and in so many parts of the country that it is difficult to know in how many schools and where it is given.

The schools giving secondary work in agriculture may be classified as follows:

(a) Secondary schools of agriculture in connection with the colleges of agriculture. The Minnesota school is of this type, and similar schools of agriculture, or two-year or three-year practical courses, are now maintained in connection with the colleges of agriculture in Alabama, Arkansas, California, Colorado, Connecticut, Delaware, Florida, Idaho, Kentucky, Louisiana, Maine, Maryland, Minnesota, Mississippi, Montana, Nebraska, Nevada, New Hampshire, New Jersey, New Mexico, North Dakota, Ohio, Oklahoma, Oregon, Pennsylvania, Porto Rico, Rhode Island, South Dakota, Texas, Utah, Virginia, Washington, West Virginia, Wisconsin, and Wyoming. In addition, a number of the agricultural colleges are giving instruction which is secondary

in nature, though it may not be recognized as such. The 16 land grant colleges for the colored race in the Southern states are in large part secondary schools, their subcollege courses representing at least two thirds of their work. These institutions have chosen to produce a large body of practical negro farmers for the South rather than to produce a few highly trained negro experts.

(b) Agricultural high schools located in large districts, such as those in Alabama, Georgia, Virginia, and Minnesota. Alabama was the first state to organize such schools, and now has 9, one located in each congressional district. Each school has a branch experimental station connected with it; it is provided with land for experimental and instructional purposes; has an equipment of buildings, animals, and machinery; and receives a state appropriation of \$4500 a year for maintenance. Georgia has 11 such schools, similarly located. Land, buildings, and equipment were furnished almost entirely by local contributions, and out of the income from fees and taxes the state grants about \$7500 a year to each school for maintenance. Each school has not less than 200 acres of land. The schools in each state give a four-year course. Other states having somewhat similar schools are California and Minnesota, where one state school is provided; New York, with three such schools; Oklahoma, with one such school provided for each of the five judicial districts of the state; and Virginia, where it is proposed to establish one in each of the ten congressional districts of the state. In Massachusetts a comprehensive scheme of specialized agricultural high schools was planned by the State Industrial Commission, the plan being to locate ten schools at different places in the state, and to divide the state into ten large agricultural districts. Under the supervision of the Board of Education, which succeeded to the work of the Industrial Commission, about a dozen schools have been established. Some of these have the county as a basis, some the town.

The district plan is perhaps the best arrangement for such schools, as the state can then be divided into natural agricultural districts, and a school located in each.

(c) County agricultural high schools, as in Michigan and Wisconsin. The first of these was established in Wisconsin in 1902, and four are now in existence. These schools are built and equipped at the expense of the counties where they are located, but the state makes a grant of \$4000 a year for each school. The Marathon County school at Wausau, and the Dunn County school at Menominee were opened in 1902, and similar schools have since been opened at Marinette and Winneconne. The course of study in each is two years in length, and contains much practical and little academic work. There is a county agricultural high school also at Menominee, Michigan; and Mississippi has recently provided for state aid of \$1000 a year to county agricultural high schools, one to be located in each county in the state. County agricultural high schools are also to be found in Maryland. Experience so far seems to indicate that the county is too small a unit for the proper equipment and maintenance of a good agricultural high school.

(d) State and county normal schools. Over 100 normal schools in the United States were giving instruction in agriculture in 1909. In some schools a regular course is given by a trained agricultural teacher, while in others the work is done as a part of the science work. In all such schools the aim of the work is to prepare teachers of the subject for work in the elementary schools.

(e) Regular high schools, offering instruction in agriculture as a part of their course of instruction. In such schools no uniform plan is followed. In some the work consists of but one or two courses; in others a number of elective agricultural studies are offered; while in still others a regular agricultural course is given parallel with the other courses of the school. In a few schools the work is somewhat limited and specialized

along such lines as horticulture or floriculture. Something like 400 schools were offering such instruction at the close of the school year in 1909, and the number has increased since then. In Missouri alone over 200 high schools reported some instruction in agriculture. In some places, and even throughout some states, the existing high schools are being reorganized so as to make them in large part agricultural high schools. *Circular No. 91*, Office of Experiment Stations, U. S. Department of Agriculture, gives detailed courses of instruction in horticulture and agriculture, as these have been adopted by the Association of American Agricultural Colleges and Experiment Stations.

(f) Private schools, or semi-private schools. In this class should be placed the National Farm School, at Doylestown, Pennsylvania, established in 1896 to provide instruction and practical farm work for about 40 boys; the agricultural department of the Mount Hermon School, near Northfield, Massachusetts, where instruction was begun in 1903; the Smith Agricultural School and Northampton School of Technology, at Northampton, Massachusetts, opened in 1908; the Winona Agricultural and Technical Institute at Winona Lake, Indiana, established in 1902; Tuskegee in Alabama; and a number of privately endowed colleges, which afford secondary instruction in agriculture as a part of their work, and nearly all of which are located in the upper Mississippi valley. The schools at Doylestown, Northampton, and Tuskegee also receive some state aid. At Groton, Massachusetts, a school of horticulture and landscape gardening for women has been opened, and a course in horticulture is now given at Wellesley College.

THE PRESENT PROBLEM. — What is the best way to develop secondary instruction in agriculture is as yet a somewhat unsettled question. Whether it is better to aid the present school system to evolve agricultural instruction out of the present work, and thus make agricultural instruction

an integral part of the regular school system; or whether special and independent schools for the teaching of agriculture and domestic subjects should be established, has not as yet been decided. The latter method at present seems to meet with greater favor from practical men, but many educators favor the former plan, believing that the inclusion of agricultural instruction in the regular work of the secondary schools, rather than its separation as a special kind of education for which special and independent schools need to be established, is best for us as a nation. It was this conception of the unity of all education which led to the opposition, from educational workers, to the congressional proposal of 1908 to grant aid from the national treasury toward the establishment of separate secondary schools of agriculture in the different states. It is probable that both types of schools will be needed, and will exist side by side, the larger and more specialized schools being organized for agricultural districts, as was proposed for Massachusetts, and some agricultural instruction being introduced into most of the town and rural high schools.

TOPICS FOR FURTHER STUDY

1. What is the attitude of the modern trade union towards industrial education?
2. What is the attitude of the modern employer or of organizations of employees towards industrial education?
3. What are the advantages and the disadvantages of the evening school as an instrument of industrial education as seen in concrete cases?
4. What are the merits and the difficulties in the actual details of arrangement of the part-time coöperative plan as seen in American attempts? In German?
5. What are the social and economic conditions which render desirable the public support of commercial education?
6. What place has commercial education in public high schools? In the high school of the small city or town?
7. Is a part-time coöperative plan possible or desirable in the commercial field as it is in the industrial?

8. What are the merits and advantages of the German system of commercial education over our own? Of that of any other European system over our own?

9. What is the attitude of the business or commercial classes towards commercial education? How can coöperation between them and the school be brought about?

10. What differences exist in the social and industrial conditions at the time of the manual training movement of the eighties and nineties and similar conditions producing the industrial and trade education demands of the present?

11. What differences or similarities are found in a comparison of American conditions with those of any one European country where industrial education has been developed?

12. What can we learn direct from the industrial or trade schools of Germany regarding curriculum, method, or organization? Of France? Of any other European country?

13. What are the advantages or disadvantages of the old apprenticeship system of industrial training over the present?

14. Trace out the actual workings of the apprenticeship system of industrial education in any one country or in any one industry.

15. In any one industry or in any one community what are the difficulties existing at the present time in operating a system of industrial education?

16. What facts can be adduced to support the reasons given in the text for the decline of interest in agricultural education following the Civil War?

17. What facts can be adduced to support the reasons given in the text for the recent growth of interest in agricultural education?

18. What should be the relation between the agricultural colleges and the agricultural high schools?

19. What should be the relation between the agricultural colleges and the farming population? What between the agricultural high schools and the farming population?

20. What concrete problems of agriculture can be studied in a high school course in agriculture?

21. What are the merits and demerits of each type of the agricultural high school given in the text?

22. What can we learn from the work of the secondary agricultural schools of Germany applicable to conditions in the United States? From France? From other European countries?

23. What differences in curricula should be made between the various types of agricultural secondary schools mentioned in the text? What in method?

REFERENCES

Industrial Education

A comprehensive bibliography of works on Industrial Education is given in the *Twenty-fifth Annual Report* of the U. S. Commissioner of Labor, pp. 521-539. In the following list only the most important and most accessible titles are given.

- CARLTON, F. T. *Education and Industrial Evolution*. New York, 1908.
- CREASEY, C. H. *Technical Education in Evening Schools*. London, 1905.
- DRAPER, A. S. *Our Children, our Schools, and our Industries*. *Annual Report*, New York State Education Department. Albany, 1908.
- DUTTON, S. T., and SNEDDEN, D. S. *Administration of Public Education in the United States*. New York, 1908.
- GERMER, B., editor. *Die Fortbildungs- und Fachschulen in den grösseren Orten Deutschlands*. Leipzig, 1904.
- HANUS, P. H. *Beginnings in Industrial Education*. Boston, 1908.
- HOWARD, E. D. *The Cause and Extent of the Recent Industrial Progress of Germany*. Boston, 1907.
- KERSCHENSTEINER, GEORG. *Organisation und Lehrpläne der obligatorischen Fach- und Fortbildungsschulen für Knaben in München*. Munich, 1910.
- Jahresbericht der manulichen Fortbildungs- und Gewerbeschulen Münchens*. Annual since 1907. Munich.
- Staatsbürgerliche Erziehung der deutschen Jugend*. Erfurt, 1909.
- KIMMINS, C. W. *Trade Schools in England*. *Elem. Sch. Teacher*. Vol. X, pp. 209-219.
- LAUTZ, TH. *Fortbildungs- und Fachschulen für Mädchen*. Wiesbaden, 1902.
- Massachusetts Commission on Industrial and Technical Education, *Report*. Boston, 1906.
- Second Annual Report*. Boston, 1908.
- National Society for the Promotion of Industrial Education. *Bulletins*, New York.
- New York State Department of Labor. *26th Annual Report* of the Bureau of Labor Statistics, Part I. Industrial Training. Albany, 1909.
- PACQUIER, J. B. *L'Enseignement professionnel en France; son Histoire; ses différentes Formes; ses Résultats*. Paris, 1908.
- PERSON, H. S. *Industrial Education*. Boston, 1907.
- Place of Industries in Public Education. *Proceedings, N. E. A.* 1910.
- SADLER, M. E. *Continuation Schools in England and Elsewhere*. Manchester, 1908.

- Technical Education in France. *L'Enseignement technique en France. Étude publiée à l'Occasion de l'Exposition de 1900.* Paris, 1900.
- U. S. Bureau of Labor. Conditions of Entrance to the Principal Trades. *Bulletin*, No. 67, 1906. Washington.
- U. S. Commissioner of Labor. Industrial Education. *Twenty-fifth Annual Report.* Washington, 1910.
- U. S. Commissioner of Labor. Trade and Technical Education. *Seventeenth Annual Report.* Washington, 1902.
- U. S. Department of Commerce and Labor. Industrial Education in Germany. *Special Consular Reports*, Vol. XXXIII. Washington, 1905.
- WARE, FABIAN. *Educational Foundations of Trade and Industry.* New York, 1901.
- WRIGHT, C. D. The Apprenticeship System in its Relation to Industrial Education. U. S. Bureau of Education, *Bulletin*, No. 6. Washington, 1908.
- Manual Training*
- BALDWIN, W. A. *Industrial Social Education.* Springfield, Massachusetts, 1903.
- CLARKE, I. E. *Education in Fine and Industrial Art in the United States.* U. S. Bureau of Education. 4 vols. Washington, 1885-1898.
- Council of Supervisors of the Manual Arts Year Books. 1903-1909.
- DEWEY, JOHN. *The School and Society.* Chicago, 1899.
- DOPP, KATHARINE. *The Place of Industries in Elementary Education.* Chicago, 1903.
- Educational Monographs.* New York College for the Training of Teachers. New York, 1888-1890.
- GOETZE, WALDEMAR. *Hand and Eye Training.* London, 1894.
- HAM, C. H. *Manual Training.* New York, 1886.
- Ireland, *Reports and Minutes of Evidence of the Commission on Manual and Practical Instruction in Primary Schools under the Board of Education in.* 7 vols. London, 1897.
- Manual Training Magazine.* Peoria, 1899-
- N. E. A. Various Papers. *Proceedings*, 1884-
- Report of Committees on Place of Industries in Public Education*, 1910.
- SALOMON, OTTO. *Theory of Educational Sloyd.* Boston, 1896.
- SCHMITT, E. *La Pédagogie du Travail Manuel.* Paris, 1895.
- Teachers College Record. *The Elementary School Curriculum.* New York, 1908.
- U. S. Bureau of Education. *Reports.* Washington, 1887-
- WOODWARD, C. M. *The Manual Training School.* Boston, 1887.
- Educational Value of Manual Training.* Boston, 1890.
- Manual Training in Education.* New York, 1891.

Commercial Education

- BARBER, E. M. *A Contribution to the History of Commercial Education.* Brooklyn, 1903.
- Bulletins of University of Pennsylvania, Dartmouth College, New York University, University of Wisconsin, University of Chicago, University of California, Harvard University, University of Iowa, and others.*
- HARTOG, P. J. *Commercial Education in the United States.* Board of Education, *Special Reports on Educational Subjects*, Vol. XI. London, 1902.
- HASKINS, CHARLES WALDO. *Business Education and Accountancy.* New York and London, 1904.
- HERRICK, CHEESMAN ABIAH. *Meaning and Practice of Commercial Education.* New York and London, 1904.
- HOOPER, F. and GRAHAM, J. *Commercial Education at Home and Abroad.* New York and London, 1901.
- JAMES, EDMUND JANES. *Commercial Education.* Albany, N. Y., 1900.
Education of Business Men. New York, 1893.
- London Chamber of Commerce. *Conference on Commercial Education.* London, 1898.
- London School of Economics and Political Science. *Brief Report of the Work of the School since 1895.* London, 1899.
- Michigan, Political Science Association. *Higher Commercial Education.* Ann Arbor, Mich., 1903.
- Proceedings and Addresses of the Department of Business Education in the National Education Association, 1897-1909.*
- Reports of the U. S. Commissioner of Education, 1885-1909.*
- SADLER, MICHAEL E. *Higher Commercial Education in Antwerp, Leipzig, Paris, and Havre.* Board of Education, *Special Reports*, Vol. III. London, 1898.
- Recent Developments in Higher Commercial Education in Germany.* Board of Education, *Special Reports*, Vol. IX. London, 1902.
- VANDERLIP, FRANK ARTHUR. *Addresses on Commercial and Technical Education.* New York, 1905.
- WARE, FABIAN. *Educational Foundation of Trade and Industry.* New York, 1901.
- WHITFIELD, E. E. *Commercial Education in Theory and Practice.* London, 1901.

Agricultural Education

- BAILEY, L. H. *On the Training of Persons to teach Agriculture in the Public Schools.* *Bull. No. 1*, 1908, U. S. Bur. Educ., pp. 53, 2 pp. bibliography on agricultural education. Washington, 1908.

- BAILEY, L. H. *The Training of Farmers*, The Century Co., 1909.
- BAILEY, L. H. *Education by Means of Agriculture. Cyclopedia of American Agriculture*. Vol. IV, ch. viii, 1909. Historical and descriptive.
- BETTS, G. H. *New Ideals in Rural Schools*. Boston, 1911.
- CARNEY, MABEL. *Country Life and the Country School*. Chicago, 1912.
- CUBBERLEY, E. P. *Rural Life and Education*. Boston, 1907.
- ELLIS, A. CASWELL. *The Teaching of Agriculture in the Public Schools*. Univ. of Texas, *Bull. No. 85*, 56 pp. Austin, 1906.
- EGGLESTON, J. D., and BRUERE, R. W. *The Work of the Rural School*. New York, 1913.
- FISKE, G. W. *The Challenge of the Country*. New York, 1912.
- FOGHT, H. W. *The American Rural School*. New York, 1910.
- JEWELL, J. R. *Agricultural Education. Bull. No. 2*, 1907, U. S. Bur. Educ., 140 pp. Bibliography of 123 titles. Washington, 1907.
- HART, J. K. *Educational Resources of Village and Rural Communities*. New York, 1913.
- KERN, A. J. *Among Country Schools*. Boston, 1906.
- N. E. A. *Report of the Committee on Industrial Education for Rural Communities*, 1905. 97 pp. *Supplementary Report* of 45 pp. in 1907. Published separately, and also in *Proc. N. E. A.* for 1905 and 1907.
- SEERLEY, H. W. *The Country School*. New York, 1913.
- U. S. Bureau of Educ. *Annual Reports*.
The Teaching of Agriculture in the Schools of France and Belgium; in Rept. for 1905, Vol. I, pp. 87-96.
Agricultural High Schools; in Rept. for 1909, Vol. I, pp. 146-150.
- U. S. Dept. of Agriculture; Office of Experimental Station, Circulars:
 No. 49, TRUE, A. C. *Secondary Courses in Agriculture*. 10 pp. 1902.
 No. 60, TRUE, A. C. *The Teaching of Agriculture in the Rural Common Schools*. 20 pp. 1904.
 No. 69, TRUE, A. C. *A Four Years' College Course in Agriculture*. 36 pp. 1906.
 No. 73, TRUE, A. C. *Country Life Education*. 13 pp. 1907.
 No. 77, TRUE, A. C. *A Secondary Course in Agronomy*. 44 pp. 1908.
 No. 83, TRUE, A. C., and CROSBY, D. J. *The American System of Agricultural Education*. 27 pp. Ill. 1909.
 No. 84, HAYS, W. M. *Education for Country Life*. 40 pp. 1909.
 No. 90, ABBEY, M. J. *Normal School Instruction in Agriculture*. 31 pp. 1909.
 No. 91, TRUE, A. C. *Secondary Education in Agriculture in the United States*. 11 pp. 1909. Outline courses of study in Horticulture and in Agriculture.
- U. S. Dept. of Agriculture; Office of Experimental Stations, Bulletins:
 No. 186, CROSBY, D. J. *Exercises in Elementary Agriculture*. 48 pp. 1907.

CHAPTER XVIII

HYGIENE AND PHYSICAL EDUCATION

HYGIENE. — Hygiene (from *ὑγιεία*, hygiene, health) is usually defined as the science that treats of the prevention of disease and the preservation of health. It is especially an applied science, and, in a certain sense, an art. It aims, in the words of a modern writer, “to make growth more perfect, life more vigorous, decay less rapid, death more remote.” The positive note in this definition of aims is characteristic of recent hygiene. It is no longer satisfied with the mere attempt to prevent disease, but it emphasizes especially the need of normal healthful development and the acquisition of vigorous habits of health that shall be prophylactic against disease.

PERSONAL HYGIENE. — Personal hygiene consists of two important parts, somatic hygiene and mental hygiene. On account of the great individual differences in strength, endurance, ability to work and to resist disease, the problem in both these fields must be an individual one. Mental hygiene is quite as important for the teacher and pupil as somatic hygiene, and the teachings of mental hygiene and the hygiene of instruction are so important for sound education that for pedagogical as well as hygienic reasons the school cannot ignore them.

The subject has also important social aspects. In its wider sense personal hygiene is the very basis of disease prevention and health preservation. All plans for community or national freedom from disease must rest upon and depend upon the care with which the individual members of society settle their problems in personal hygiene. If every member of any

given social unit would persistently apply his rights of franchise in favor of more stringent and effective laws of hygiene and sanitation, the problems of personal hygiene would be far easier. The difficulties of personal health control are largely difficulties which are of a community origin. The transgressions of one member of a community are visited upon the lives of his innocent fellow citizens. Equity in matters of this kind is secured only through law backed by strong popular sentiment. Then, if every member of any given social unit is protected from hygienic or sanitary injury inflicted by his fellow citizens, he may organize his policy of personal health control with every prospect of success. Under such circumstances it would be possible to develop a community in which each member practiced intelligent habits of bodily nourishment, supervising the food he would eat, the food he would drink, and the food he would breathe; intelligent habits of excretion; intelligent habits of exercise; intelligent habits of rest; and intelligent habits of cleanliness. Men of such habits are men of health, men of strength, men of efficiency. A community or a nation with such habits would have solved the problem of prevention of disease and have conserved its resources in terms of human life, human happiness, and human prosperity, with all that such conservation means economically, socially, and politically.

Another very important relationship of personal hygiene is its relationship to intellectual efficiency. The uncorrected, incapacitating, remediable physical defects of school children; the time lost through absences due to preventable disease; the paralyses and other organic degenerations following the preventable diseases and leaving chronic incurable conditions obstructive of further mental development and destructive of that already attained; the disturbed home conditions producing nervous strain, poverty, undernourishment, and lowered resistance, following parental disease or death — all are samples of serious avoidable and preventable conditions affecting the intel-

lectual activities of school children. If the personal hygiene of school children and the personal hygiene of the communities in which they live were what they ideally ought to be and what they could be, these destructive conditions could not exist.

Furthermore, the aggressively healthy child is the most efficient child academically as well as physically considered. The teacher working with sound healthy minds will secure larger educational results than under less normal conditions. This fact is effectively proved by the experiences of our open-air schools; the introduction of school lunches; the progress of pupils who have been relieved of incapacitating physical defects; and the studies of men who have compared schools and school children representing various types of physiological health.

The Scope of Personal Hygiene. — In its narrower sense, personal hygiene has been construed as including only those physiological and anatomical and very intimate personal relationships and habits which are obviously personal. Such a conception would bring the following topics under the heading of "Personal Hygiene": Care of the clothing, skin, scalp, nails, eyes, ears, nose, teeth, mouth, throat, heart, lungs, alimentary canal, genito-urinary organs, bones, joints, brain and nervous system, food, water, ventilation, tea, coffee, alcohol, and tobacco. In some texts "first aid to the injured" is included.

A wider construction of the scope of personal hygiene includes everything that bears upon the health of the human body. Such a scope would include the various subtopics connected directly and indirectly with the following subjects: Bodily nourishment, including food, water, and air; the excretions; exercise; rest; the influence of abnormal conditions on health (*e.g.* defective vision, bad teeth, adenoids, constipation); the influence of certain habits on health (*e.g.* rapid eating, bad habits of vision, smoking, drug habits, sexual habits, etc.); the causes of disease; the carriers of

disease; our defenses against disease; and the nature of our common diseases.

Personal hygiene considered from this point of view would be rational and comprehensive. Its relationship to sex hygiene, domestic hygiene, school hygiene, medical inspection, school nursing, community hygiene, industrial hygiene, military, naval, and national hygiene is obvious. These special divisions of hygiene are important because they represent personal hygiene under special conditions. The hygiene of all society and of all the enterprises of society depends upon the hygiene of the individual. On the other hand, the individual is more than powerless unless society as a whole stands for such regulations and such customs as will make possible, easy, and practical the application of the laws of health.

TEACHING OF HYGIENE.—The importance of the teaching of hygiene can hardly be overestimated. Health represents a universal human interest. Its importance can be estimated only in terms of human value. Efficiency, to adopt the modern slogan, is impossible without it. Both directly as contributing to personal well-being and indirectly as contributing to the welfare of others, health is a prime condition of human happiness and even of morality. Such truths, which are so commonplace as to be merely platitudes, should not only be taught to the young, but should be made vital by training. Hence the aim of education from the point of view of hygiene is the development of habits of healthful activity both physical and mental. This training in habits of health should be supplemented by suitable instruction at different stages. To insure such training and such instruction, proper training and an adequate course in hygiene are imperative in the preparation of all teachers. This is the consensus of opinion of hygienists, and a resolution to emphasize this need was passed by the Second International Congress of School Hygiene at London, 1907.

Instruction in Hygiene in the Schools. — The extent to which instruction in the principles and practice of hygiene has been introduced into the schools of the United States is indicated by the recent investigations of the American School Hygiene Association. Meylan reported on 116 colleges, of which 75 per cent were giving instruction in hygiene. Twenty-six per cent of the colleges reporting on the details of their work were giving instruction in personal hygiene only; 24 per cent were giving instruction in general hygiene; others reported in smaller percentages that instruction was being given in emergencies, community hygiene, industrial hygiene, and mental hygiene. Seventy-nine per cent of these colleges reported that students were required to undergo a medical examination before taking up their work. Seventy-nine per cent reported regular sanitary inspections of school buildings and dormitories; 77 per cent inspected kitchens; 83 per cent inspected the water supply and grounds. Twenty per cent of these colleges accepted hygiene as a credit for admission.

Gulick reported on 90 public normal schools and on 2392 public high schools. Seventy-four per cent of the normal schools and 16 per cent of the high schools were giving instruction in hygiene. At the last Congress of the American Hygiene Association, Gulick reported on 758 cities having graded public school systems. He found that 45 per cent of those cities "have regular organized systems of medical inspection in their schools" and "about one quarter of the cities have systems under the Board of Health" and three quarters are under the Board of Education. "Only a little more than one half of them undertake physical examinations." Seventy-six of those cities were employing school nurses, and forty-eight, school dentists. Twenty-five per cent of those cities were using individual drinking cups, and 75 per cent had sanitary drinking fountains. In some of the cities both systems were in use. "Over one half of these schools use

moist cloths for dusting; in nearly all of them dust-absorbing compounds are used in sweeping; and in nearly a tenth of them the schools are supplied with vacuum cleaners." Most of these cities reported that their schoolroom floors were washed once in a month or once in three months, "although it is by no means rare to find cities in which they are washed once in five months or never washed at all." Adjustable desks are reported in about one half of the cities heard from. "Ninety-five per cent of the cities teach their children the effects of alcohol and tobacco; 61 per cent have special courses on the prevention and cure of tuberculosis, and 48 per cent give lessons in first aid." It is very evident from these reports that a large number of the larger cities in the United States have made provision for instruction in the principles of hygiene and have organized systems of medical and hygienic supervision which must be more or less effective in establishing the practice of hygiene.

Scope of a Course in Hygiene. — Authorities differ as to the proper content of a course in the principles of hygiene. The older texts combined a study of anatomy and physiology with a study of the influences that act injuriously upon the organs and therefore upon their physiological activities. Some of the later texts minimize the amount of anatomy and physiology presented and emphasize the presentation of more purely hygienic material.

Leaving out of consideration the essential value of an intelligent knowledge of the main facts of human anatomy and physiology, there remain obviously very strong reasons why an intelligent knowledge of hygiene is impossible without an equally intelligent knowledge of anatomy and physiology. The teacher must be well informed in these fundamentals, for he cannot afford to be ignorant of the basis of his subject. The pupil must necessarily be content to take many things for granted, but his hygienic education will be more valuable in the proportion in which it is based on a real knowledge of

its scientific basis. The amount of time necessary to give an adequate knowledge of physiology and anatomy will depend on whether or not physiology is taught elsewhere in the curriculum as well as on the age of the pupil and on the phase of hygiene under consideration.

There are different points of view also concerning the content of elementary, intermediate, and advanced courses in their relation to each other. A common plan is to consider the same subject matter year after year, going more deeply into the details each time. The opposite plan is to take up new phases of hygiene each term, utilizing at the same time the facts already presented. Another variation in the conception of the proper content of a course in hygiene is that which includes procedures calculated to develop the practice of hygiene. Habit is most important. We must have the knowledge, but the knowledge is of little use if it is not applied in the daily habits of the individual. The procedures that tend to develop habits of hygiene are physical exercise (games, sports, plays), swimming, bathing, toothbrush drills, hygienic and medical inspection with the correction of bad habits of hygiene, and of remediable incapacitating physical defects, routine exclusions for contagious cases and cases exposed to contagious disease. This conception combines instruction in the principles of hygiene with instruction in the practices of hygiene. It unites classroom instruction with the applications of hygiene in the various departments and divisions of the school.

It is most desirable from the standpoint of educational method and effective results to combine the essentials of related anatomy and physiology with a carefully graded sequence of hygienic subjects; at the same time insisting on the practice of health habits and procedures from those of simple cleanliness and exercise up to those of individual relief from the handicap of physical defect and those of community protection against communicable disease.

Methods of Instruction in Hygiene. — There is the same necessity for sound educational methods in presenting the subject of hygiene to school children or college students as there is in the presentation of any other subject taught them. The object of this instruction in hygiene is the establishment of right habits of living based upon a rational knowledge of the reasons why those habits are right. The subject is essentially scientific in its foundations and logical in its application. All the arguments that have been advanced in support of better educational methods of teaching scientific subjects and all the arguments that have been advanced in support of educational methods that will best develop the power of reasoning are arguments in favor of the employment of the best educational methods in the teaching of hygiene. The subjects which are basal to hygiene, such as physiology, anatomy, and bacteriology, should be taught by the methods that have been found most effective for those subjects. The need for dissections, models, illustrations, diagrams, charts, specimens gross and histologic, and clay molding in anatomy; of illustrations, references, laboratory experiments, and so on in physiology; of cultures, experiments, and specimens in bacteriology is as urgent when these subjects are a portion of a course in hygiene as when they are independent.

The Teaching of Hygiene in the High School. — The curricula of our schools are already overcrowded. The addition of hygiene as a complete subject means a large addition. For these reasons there are very few schools in which hygiene is presented in anything like its complete form. The commonest school method is that which utilizes a selected textbook from which the pupils prepare their recitations. Charts, diagrams, illustrations, and practical questions accompany the recitations. Where departments of biology exist, or where physiology or bacteriology is taught, these subjects are often made to cover hygiene or various parts of it. Many of our high schools and colleges are placing hygiene

in the Department of Physical Education, where it has a peculiar appropriateness. A good deal of hygiene is taught by the medical inspectors and nurses in some of those schools that have an efficient system of medical inspection.

There should be careful correlation between the instruction in the principles of hygiene on the one hand and on the other hand the procedures and conditions of applied hygiene and sanitation as they exist in the school system, its buildings, grounds, and material equipment. The educational influences from these various sources should be harmonious. There should be no inconsistencies between general scientific hygienic principle and local hygienic practice. The subject matter in any given course in hygiene should include particularly the hygienic features connected with the health problems which occur in the daily lives of the individuals concerned. Such a course would logically include the following topics: Food; its physiological importance and requirements; its source; its contaminations; its preparation; its ingestion; the influences of emotional states on its digestion; its assimilation and its excretion. Water; its physiological importance; its contamination. Air; its physiological importance; its contaminations; its alterations under various meteorological conditions; ventilation. The excretions; their physiological significance; care of the bowels; the kidneys; the skin; the lungs. Physical exercise; its importance; its necessity; its varieties; its abuse. Rest; mental and physical rest; relative rest and recreation; sleep. The influence of abnormal conditions on health; *e.g.* defective vision; obstructed breathing; adenoids; tonsils; defective and unclean teeth; diseased gums; sluggish ulcers, wounds, and old areas of irritation; exposures to heat, to cold, to moisture, and to drafts; fatigue. The effects of bad habits on health; *e.g.* rapid eating; mouth breathing; unwise use of the eyes; sex habits; the abuse of tea, coffee, alcohol, and tobacco; opium and cocaine habits. The causes of disease, such as pathogenic

bacteria and other parasites. The carriers of disease, such as the fly, the mosquito, the flea, the rat, and careless human beings. Our defenses against disease, such as fresh air, sunshine, cleanliness, and good health. Special hygiene, such as domestic hygiene, municipal hygiene, community hygiene, industrial hygiene, school hygiene, "sex hygiene." First aid to the injured, and the care and feeding of infants.

Legal Requirements. — In most city school systems special emphasis is laid on the unhygienic influences of alcohol and tobacco. A number of state legislatures have enacted laws requiring such instruction in the schools of the state. The importance of this instruction is great. No course in hygiene can be complete without including a discussion of alcohol and tobacco. There is, however, a question as to the wisdom of specifying through state law that these subjects be included unless the law is made to cover in addition other equally important subjects such as dental hygiene, the hygiene of alimentation, pathogenic bacteria, the fly and the mosquito as carriers of disease, spitting, and so on. Emphasizing the importance of instruction concerning the unhygienic effects of alcohol and tobacco through legal procedure must inevitably make other seriously important phases of hygiene seem to be a matter of secondary consideration.

SCHOOL HYGIENE. — School hygiene, one of the most important departments of public hygiene, is concerned with the conditions of health in the schoolroom and the sanitation of the school surroundings. During the last fifty years the scientific method has been more and more employed in this field, and a solid nucleus of scientific fact has been collected. A rich literature has been contributed in the form of articles, not only in the special periodicals devoted to the subject, in reports, proceedings of societies, and the like, but in the archives of hygiene, of medicine, physics, psychology, anthropology, and even in those of architecture and engineering as well as in the educational journals.

School hygiene draws its facts from many sources, and naturally it overlaps other related subjects, such as general hygiene, sanitary engineering, medicine, child hygiene, etc. The subject naturally divides into three parts — the construction and sanitation of the schoolhouse, the hygiene of the school child, and the hygiene of instruction. All of these are, of course, ultimately concerned with the health of the child, but the classification is a convenient one. The aim of all of these is positive, the development in the school child of habits of healthful activity. Especially and directly is this true of the last two divisions — the hygiene of the school child and the hygiene of instruction.

Hygiene of the School Child. — Child hygiene in an important sense is a special subject because the child's body differs from that of the adult. The hygiene of the school child demands special consideration because of the special work required in the school. It is based upon the character of the child's body and the laws of growth, and it seeks to determine the needs and to avoid the dangers of each stage of development. Hence among the important contributions to school hygiene in the last twenty-five years have been many scientific studies of growth and development, of the diseases and abnormalities of school children, and of the defects of the various sense organs. Thus the relation of physical development to intelligence, the incidence of disease by years, by grades, by seasons, by months of the school year, the relation of defects to school progress, etc. Methods of detecting and controlling contagious diseases have been investigated, and certain important correlations have already been established. By the introduction of health inspection into the public schools in recent years not only is the importance of school hygiene emphasized, but a large amount of valuable material for the study of the subject is being collected. The school should be made the most important factor in public hygiene; for in it practically all the children are collected, and conditions can be con-

trolled in the interests of health. The prime importance of this part of school hygiene for the teacher is obvious.

Hygiene of Instruction. — While this department of school hygiene may be said to have begun with the Greeks and been treated by Comenius, it has been developed only in recent years. It is now so important, however, that Burgestein devotes some four hundred pages to it in the second edition of his handbook, and each year brings important new contributions. It emphasizes the hygienic importance of the mental habits formed by education and of the secondary effects of instruction, and it studies every educational principle and method and the matter of instruction from the point of view of hygiene. Thus each subject of instruction is considered with regard to the effect of the discipline on health.

The many problems concerned with the period of study — fatigue, the best alternation of periods of work and rest, the length of the school day, one session or two, recesses, pauses, etc. — have all been made the subject of scientific investigation. The importance of this newer field of school hygiene is seen when one considers the fact that an important means of curing nervous and mental disorder is reëducation, the development of healthful habits of mental activity, — wholesome interests, habits of attention, self-control, and orderly association, — in fact, the very habits that are essential for hygienic school-work. And when one further reflects that the inmates of such institutions were a few years ago pupils in the public schools, the advantage of developing such habits as prophylactic against nervous and mental breakdown is obvious. More and more scientific investigation and observation are showing the hygienic importance of such mental training; and the hygiene of instruction has become of vital significance to the teacher.

The Construction and Sanitation of the Schoolhouse. — First of all the sanitary surroundings of the schoolhouse have been made the subject of investigation. The schoolroom

is a workshop. The conditions must be made hygienic for the work to be done in it. The work required is performed chiefly by the brain, by the eye and ear, and by the hand under the control of the eye and the brain. Thus the conditions necessary are not merely the avoidance of whatever would be injurious, — a stagnant, poisonous, arid, or overheated atmosphere, too intense light, glare from surrounding buildings, noisy occupations, unsuitable rooms, etc.; but in every way the optimum conditions for such work — especially abundant and properly regulated light and an ample supply of oxygen. So important is the condition last mentioned both for the health of the pupils and for the work to be done that the desirability of schools out of doors, or in conditions approximating those out of doors, is now being emphasized. Since in most parts of the country, however, a large amount of indoor work seems necessary on account of inclement weather, it is becoming more and more important to provide hygienic conditions in the schoolroom.

Thus this department of school hygiene is concerned first of all with the optimum conditions for a workshop where the laborers are growing children and the labor brain work. Architectural and artistic considerations are important, but secondary. First of all must be considered the health of the workers. For example, the unit in a schoolhouse is the schoolroom, and the size of the room should be determined by consideration of the average limits of normal sight and hearing; while the problem of construction is that of grouping a sufficient number of such units in a schoolhouse in a convenient way to give suitable light, air, etc. Many scientific studies have been made of the best forms of construction, and of methods of heating, ventilation, lighting, etc.; and from these and the experience in building millions of schoolhouses certain definite norms for construction have been established. If we could bring together into one schoolhouse all the good features that are actually incorporated in various schoolhouses throughout

the country, features which actual experience has shown to be of practical utility, we should have a model schoolhouse. Most schoolhouses, however, are seriously defective in certain aspects, and some apparently ignore modern hygiene altogether.

PHYSICAL EDUCATION. Early Conceptions. — In time past and in our own time physical education has been exalted, tolerated, neglected, or denounced, according to the prevailing conceptions as to the nature of the human body and of its relations to the human mind. The character of these conceptions has depended chiefly on the ideals of human excellence held at different periods in the history of education. Those ideals may be characterized as the Greek or æsthetic, the monkish or ascetic, the military or knightly, and the modern or scientific.

The Greek ideal recognized the unity or symmetry of body and mind as expressed by Plato in the *Timæus*. "Everything that is good is fair, and the fair is not without measure. Now, we perceive lesser symmetries and comprehend them, but about the highest and greatest we have no understanding, for there is no symmetry greater than that of the soul to the body. This, however, we do not perceive, nor do we allow ourselves to reflect that when a weaker or lesser frame is the vehicle of a great and mighty soul, or conversely, when a little soul is incased in a large body, then the whole animal is not fair, for it is defective in the most important of all symmetries; but the fair mind in the fair body will be the fairest and loveliest of all sights to him who has the seeing eye." Gymnastics were accorded a large and important place in the educational program of Greek youths. The teaching of gymnastics afforded positions of honor and emolument to distinguished and ambitious men. Bodily training furnished themes for poets, philosophers, and historians; sculptors and painters sought models in the gymnasium, and Greek physicians studied and adopted exercises and procedures originated by

teachers and gymnasts. In the breadth and sanity of its aims, the completeness of its development as a national institution, and its abiding influence upon succeeding generations, Greek physical education has no parallel.

Modern Views. — The modern or scientific ideal of physical education owes its origin to the belief "that to work the mind is also to work a number of the bodily organs, that not a feeling can arise, not a thought pass, without a set of concurring bodily processes." The sciences of biology, physiology, and psychology have furnished a basis for the study and application of the laws governing the growth, development, and education of the body and mind. Man's knowledge of himself has been immensely increased, and his conception of nature and his place in nature radically changed. One of the most prominent results of the progress made in these sciences is a deeper appreciation of the vital importance of motor training in education.

The modern or scientific ideal of physical education recognizes two chief aims: (1) health, normal growth, and development of the body as an efficient organism; (2) psycho-motor education, with emphasis on bodily control and the expression of personality or character of the individuals.

These ideals are based on the sciences of biology, physiology, psychology, and education, but physical education itself has not yet attained the dignity of a definite science. Since the somewhat crude attempt of Ling early in the nineteenth century to devise a system of gymnastics based on physiology and coördinated with educational procedure, much progress has been made in placing physical education on a scientific basis. During the period of evolution from crude empiricism to scientific principles, physical education has passed through many phases.

Three distinct systems originated in Europe and developed simultaneously: the Swedish system of educational, military, and medical gymnastics devised by Ling and his followers;

the German system of gymnastics developed by Guts Muth, Jahn, and Spiess; and the British scheme of athletics and games fostered and developed in the universities and public schools. The Swedish and German systems had for their chief aim the training of strong, self-reliant, and patriotic citizens. The athletics and games of England developed naturally in response to the normal play instinct of English boys and young men.

These well-defined national schemes for physical education have survived to the present day and spread to many lands. The Delsarte system of exercises was devised by François Delsarte in Paris, about 1840, to train actors in dramatic expression. The Delsarte plan had such a limited scope that it could not gain recognition as a system of physical education.

Forms of Exercise. — There are two main classes of gymnastic exercises: first, calisthenics, which includes free movements of arms, legs, trunk, etc. and exercises with dumbbells, wands, bar bells, Indian clubs, rings, hoops, balls, etc.; marching; and dancing. Second, apparatus gymnastics, which includes parallel bars, vaulting and horizontal bars, horse, buck, vaulting box, stall bars, jump stands, ropes, poles, ladders, and many kinds of developing appliances, such as chest weights, and other machines built on the principle of weight and pulley or friction.

Gymnastics and Athletics. — The main difference between gymnastics and athletics is one of aim. The aim of gymnastics is discipline or training for its effect upon the health, normal development, and general efficiency of the individual. The chief aim of athletics is pleasurable activity for the sake of recreation; in the athletic games of boys and young men we see the highest and fullest expression of the play instinct. While the characteristic aims of gymnastics and athletics are essentially different, some of the most important results of physical training are secured from both forms of activity. This

is true especially of the hygienic effects of muscular activity upon the circulation, respiration, digestion, assimilation, and excretion. These effects vary over wide limits according to the kind of exercise selected.

Educative Value.— In considering the educative value of gymnastics and athletics the most important principle is, that neither of these activities can serve as a substitute for the other. Each contributes some essential parts of a complete physical education. Gymnastic exercises are largely subjective in character; they serve particularly to stimulate normal physical development and to promote good carriage and easy coördination in motion and locomotion. Every gymnastic exercise is given for a definite purpose. The object may be to secure motor coördination, hygienic benefit, or some æsthetic effect. In this respect, gymnastics differs radically from athletic exercises, for in the latter the primary object is always to produce some effect outside of the individual, as hitting a ball, throwing an object as far as possible, or reaching a goal before an opponent. The effect of such exercises upon the individual is always incidental and secondary. Another advantage of gymnastics is, that selection based on scientific principles of anatomy, physiology, and mechanics makes it possible to adapt each exercise to the particular needs of the individual, with a view to producing the effect desired. The educative, hygienic, and æsthetic effects of exercise are susceptible of definite control in gymnastics, but in athletics the effects produced on the individual are indefinite and accidental. The particular effect produced by gymnastics depends partly upon the movements selected, but mostly upon the manner of their execution. The best hygienic effects are produced by adapting the movements to the strength of the individual, bringing into play the large muscles of the trunk and thighs, and accompanying the exercise with music, which adds pleasure to the work. The educative effects are best secured by careful selection and sequence of exercises

suitable to the state of psycho-motor development of the individual, and by a method of teaching which demands accuracy, precision, and speed in execution. The æsthetic effects of form, carriage, and grace of motion and locomotion result from gymnastic dancing and other exercises of the same type. The recreative value of gymnastics depends upon the ability of the teacher to make the work interesting, and in a measure upon the attitude of the student toward the work.

In general, the relative effects secured from gymnastics and athletics are as follows :

Gymnastics

Primary Effects:

Educative
Hygienic
Æsthetic

Secondary Effects:

Organic (vigor)
Recreative
Psycho-motor
Moral

Athletics

Primary Effects:

Organic (vigor)
Psycho-motor
Recreative
Moral

Secondary Effects:

Educative
Hygienic
Æsthetic

It is very evident from this table that gymnastics constitutes an essential part of a rational scheme of physical education. The results obtained from gymnastic training vary widely for the same reasons that results vary in all branches of education. Poor teaching and inadequate facilities always produce unsatisfactory results in gymnastics as in any other subject. The need for systematic psycho-motor training and vigorous muscular activity for organic development tends to increase as life becomes more complex and specialized. The growing appreciation of the physical basis of human efficiency cannot fail to bring about increased recognition for gymnastics in the school curriculum, more competent teachers, and increased material equipment.

In Schools. — In the private secondary and preparatory schools, physical education is organized much the same as in the colleges. The importance of motor education, health supervision, and moral education during the adolescent period is generally recognized by educators in the secondary schools. All the large schools and most of the smaller ones have well-organized departments of physical education in charge of professionally trained directors. The first attempt to include physical education in the program of the public schools was during the decade 1860–1870, when the calisthenics advocated by Dr. Dio Lewis had a wave of popularity. The interest lasted only a few years, and physical education was again neglected until the decade 1880–1890, when a number of Western cities with a large German population introduced light gymnastics of the German type in the public schools. The growth of cities, industrial development, and the rapid expansion during this period were factors in arousing the interest of educators and the public to the importance of providing physical training for the children in the schools. The city homes could not furnish the necessary environment for the normal physical development and motor training of the growing generation, and the need of modifying the school curriculum to meet the new conditions was recognized. In 1889 a conference in the interest of physical education took place in Boston. The conference was presided over by United States Commissioner of Education William T. Harris, and addresses were made by prominent educators, physicians, and specialists in physical education. The purpose of the conference was to “place before educators different systems of gymnastics and to secure discussion of the same, with a view to ascertaining clearly the needs of schools, and determining how they may best be met.” A direct result of the Boston conference was the organization of a department of hygiene and physical training and the adoption of the Swedish system of gymnastics in the public schools of Boston. New York and

many other cities soon followed, with the result that by 1900 nearly all the cities in the East, Middle West, and West had some form of physical education in the school program. The most common system of gymnastics in use in the school is the Swedish, or some modification of this system. A few large cities, particularly in the Middle West and Southwest, have adopted the German system.

Special directors and teachers are employed for physical training in about half of the cities where this subject is taught. The most common form of organization is a department with a director of physical training for the city, special teachers in the high schools, and supervisors in the elementary schools, who visit each class once or twice each month to criticize and help the grade teacher. The athletic activities of the school-boys were developed by the boys in many cities without direction or supervision from the school authorities. Since the organization of the Public Schools Athletic League the school authorities in many cities have taken control of this important phase of physical and moral education.

Gymnastics for Girls. — In all schemes of education, the tendency has been to provide better facilities and a more extensive curriculum for boys than for girls. This has been true particularly in regard to physical training. In Germany, England, and the United States various forms of physical training were provided for boys, while this subject was entirely neglected in schools for girls. Adolf Spiess, the founder of German school gymnastics, was the first to advocate gymnastic training for girls, but the traditional idea that womanly deportment is in contradiction to exercise has hindered the development of physical training for girls. Organic vigor and psycho-motor development are as essential to girls as to boys. The results to be accomplished are the same, but the methods employed must vary because of physiological differences in the two sexes.

The gymnastics best suited to girls include marching,

calisthenics without hand apparatus and with wooden dumb bells, wands, bar bells, Indian clubs, rings, hoops, etc.; simple exercises in vaulting and climbing (omitting, in general, all exercises requiring support of the body on the arms for more than an instant); easy exercises in jumping; and dancing. *Æsthetic* and folk dancing constitute one of the most valuable forms of physical training for girls of all ages. By means of judicious selection and adaptation, it is possible to secure from dancing most of the essential values of exercise, such as organic vigor, psycho-motor training, and recreation. Girls need also the training that comes from participation in athletic sports and team games. The qualities of courage, self-reliance, loyalty, and capacity to coöperate with others and subordinate personal interests to the interests of the team, which result from participation in team games and sports, are as desirable for girls as for boys. This training is especially valuable to counteract the tendency of some girls to be sensitive and introspective — to live too much on the subjective side of life.

In general, girls under twelve or thirteen years of age can do all except the very strenuous exercises indulged in by boys of the same age. With the onset of puberty, considerable modification of the forms of exercise given to girls is made imperative by the anatomical and physiological changes which occur at that time. The most important modifications necessary are the elimination of exercises requiring the support of the whole body by the shoulder girdle for more than an instant, the restriction of exercises involving jumping to those involving very little jarring of the body, and in general the elimination of violent exercises. The introduction of competitive athletic games in schools and colleges for girls from 1890 to 1900 was accompanied in some places by public contests between teams representing different institutions. This feature of athletics for girls has been abandoned by the leading schools and colleges because it was found to be detrimental to the best interests of education.

TOPICS FOR FURTHER STUDY

1. Should personal hygiene be taught as a special subject or in connection with the work in physical education?
2. What are the general educational and social values of a study or training in personal hygiene?
3. What are the relations between moral education and instruction in personal hygiene?
4. Should instruction in sex hygiene be made a part of instruction in personal hygiene? If so, how should instruction be given?
5. In any given school system in which you have had experience, what aspects of hygiene are taught and how?
6. What should be the scope of a course in personal hygiene for the high school?
7. What are the merits and demerits, educational, moral, social, of compulsory teaching of the effects of alcohol and tobacco?
8. To what extent are the generally accepted principles of school hygiene violated in your school?
9. What are some of the problems of school hygiene that could properly and profitably be studied by the high school pupil?
10. What are the forms of instruction in physical education in any given school? What are their merits and how could they be improved?
11. To what extent is gymnasium work desirable or necessary?
12. What modification of the standard forms of activities in physical education are desirable for high school girls?

REFERENCES

Personal Hygiene

- BLAIKIE, WM. *How to Get Strong and How to Keep So.* New York, 1899.
- CLOUSTON, T. S. *Hygiene of Mind.* London, 1906.
- FOREL, A. H. *Hygiene of Nerves and Mind in Health and Disease.* Authorized translation from the second German edition by H. A. Aikins. New York, 1907.
- GALBRAITH, A. M. *Personal Hygiene and Physical Training for Women.* Philadelphia, 1911.
- GREENE, C. A. *The Art of Keeping Well.* New York, 1906.
- GULICK, L. H. *The Efficient Life.* New York, 1907.
- HOUGH, TH., and SEDGWICK, W. T. *The Human Mechanism, its Physiology and Hygiene and the Sanitation of its Surroundings.* Boston, 1906.

- LE BOSQUET, M. *Personal Hygiene*. Chicago, 1907.
 PYLE, W. L. *A Manual of Personal Hygiene*. Philadelphia, 1907.
 STOREY, T. A. Individual Instruction in Personal Hygiene. *Proceedings of the Fifth Congress of the American School Hygiene Association*, February, 1911, pp. 149-152.
 WOODHULL, A. A. *Personal Hygiene*. New York, 1906.

School Hygiene

- ABBOTT, A. C. *The Hygiene of Transmissible Diseases*. 2d ed. Philadelphia, 1901.
 BERGEY, D. H. *The Principles of Hygiene*. Philadelphia, 1906.
 BLYTH, A. W. *Manual of Public Health*. New York, 1890.
 DRESSLAR, F. B. *School Hygiene*. New York, 1913.
 HARRINGTON, C. A. *A Manual of Practical Hygiene for Students, Physicians, and Medical Officers*. New York, 1901.
 MACFIE, R. C. *Air and Health*. London, 1909.
 NOTTER, J. L., and FIRTH, R. H. *Theory and Practice of Hygiene*. London, 1908.
 PARKES, L. C., and KENWOOD, H. R. *Hygiene and Public Health*. Philadelphia, 1911.
 SEDGWICK, W. T. *The Principles of Sanitary Science and the Public Health*. New York, 1902.
 SALEEBY, C. W. *Health, Strength, and Happiness; a Book of Practical Advice*. New York, 1908.
 STEVENSON, T., and MURPHY, S. F. *A Treatise on Hygiene and Public Health*. Philadelphia, 1892.
 WEYL, T. *Handbuch der Hygiene*. Jena, 1893. 10 vols. and Supplement, 4 vols., 1901-1904.

Periodicals:

- Archiv für Hygiene*. Herausgegeben von M. Grubner. Munich, 1896-.
Journal of Hygiene. G. H. F. Nuttall, editor. Cambridge, 1901-1910.
Journal of the American Public Health Association. B. R. Rickards, editor. Urbana, Ill., 1904-.
Journal of the Royal Sanitary Institute. Edward Stanford, editor. London, 1899-.

Teaching of Hygiene

- CABOT, R. C. The Problem of Teaching Sex Hygiene. *Proceedings of the American School Hygiene Association*, Vol. III.
 ELIOT, C. W. School Instruction in Sex Hygiene. *Proceedings of the American School Hygiene Association*, Vol. III.

- GÄRTNER, A. Hygiene-unterricht in Schulen und Seminaren. *Schulhygienisches Taschenbuch*, pp. 290-297. Leipzig, 1907.
- GULICK, L. H. Status of Physical Education in Ninety Public Normal Schools and 2392 Public High Schools in the United States. *Proceedings of the American School Hygiene Association*, Vol. II.
What American Cities are Doing for the Health of School Children. *Proceedings of the American School Hygiene Association*, Vol. III.
- HINES, L. N. Some Suggestions for a Course of Study in Hygiene. *Proceedings of the American School Hygiene Association*, Vol. III.
- STOREY, T. A. Individual Instruction in Personal Hygiene. *Proceedings of the American School Hygiene Association*, Vol. III.

Gymnastics

- ALEXANDER, A. *Healthful Exercises for Girls*. London, 1887.
- BANCROFT, JESSIE H. *School Gymnastics with Light Apparatus*. Boston, 1900.
- BETZ, C. *The Public School Gymnastic Course*. Chicago, 1894.
- DUDLEY, GERTRUDE, and KELLOR, FRANCES. *Athletic Games in the Education of Women*. New York, 1909.
- MAUL. *Turnunterricht in Mädchenschulen*. Karlsruhe, 1893, 1895, 1897.
- NISSEN, HARTVIG. *A. B. C. of Swedish Educational Gymnastics*. Philadelphia, 1892.

CHAPTER XIX

ATHLETICS

EDUCATIONAL VALUE OF ATHLETICS. — The educational values of athletics are primarily those of all vigorous neuromuscular exercise. (1) Exercise secures organic development, *i.e.* the development to the limit of inherited possibilities, during the growth of the individual from infancy to maturity, of those organs and functions that give vitality, vigor, functional power for health. (2) Exercise secures psycho-motor development, *i.e.* the development of that control of the muscular system which gives skill, body resourcefulness, and the fundamental basis for a broad “ manual,” industrial, and artistic training. (3) Exercise gives the opportunity for securing a mental and moral discipline (*a*) by giving a drill in vigorous activities which require alertness, effort, determination; (*b*) by giving self-knowledge of physical powers through comparison with others; (*c*) by giving standards for intelligent care of the body, especially the nervous system, to secure the greatest physical efficiency; (*d*) by giving discipline in self-control; (*e*) by giving concepts of “ team work ” or coöperative self-subordination and social experience under conditions that identify the youth with the social interests of the group demanding coöperation.

These values may be secured with different emphasis through industrial labor, gymnastics, vigorous play, or athletics. The aim in each of these activities is different, hence the bodily results vary. In industrial activities, the aim is industrial results; the bodily results may be and usually are very unbalanced. In gymnastics, the aim is physical development

through set, formal movements, definitely arranged and susceptible of predetermination as to results. In athletics (though they may also be taken consciously for the exercise), the aim is the contest, and the movements depend upon the exigencies of the contest. The exercise is not so easily predetermined as to results. This gives gymnastics the advantage in the precision of physical results that may be secured. In athletics the movements are more specialized and less easily controlled, though they may be graded loosely to fit individual needs and tastes. While athletics, generally speaking, secure all results, gymnastics will succeed in some cases where athletics will fail. The advantages of athletics over gymnastics arise from their competitive and social nature. While athletics may be used as gymnastics, and some forms of gymnastics may be used in the spirit of athletics, and each made to grade one into the other, athletics are fundamentally competitive and social; gymnastics are so only by consent. Athletics, being competitive and social, rouse a broader range of social impulses and emotions than gymnastics. They furnish possibilities for a deeper social stimulus and training. Gymnastics gain all fundamental results, but cannot compare with athletics in these broader disciplinary values. From the viewpoint of general education and a broad physical education, athletics must be considered coördinate with gymnastics in composing the technique of physical education for youth. Athletics probably possess the larger values, but no broad rational system of physical education can be based on either alone.

Athletics, being contests between two or more individuals, are essentially social, and require organization through mutual agreement. Several possible groupings of individuals for contests may take place in any social community. (1) Two or more individuals or groups of individuals may organize spontaneously, day by day, irrespective of social affiliations, for a contest or a period of play. This is the usual method

among town boys, town men, schoolboys, and many college men untouched by an athletic association. (2) Permanent associations may be organized to furnish facilities for contests among members, as is usually the case in local clubs such as tennis and golf associations. (3) Institutional groups or associations organized for other functions than athletics may organize for the development of facilities and the promotion of interest, as is usually the case in schools and clubs. (4) Finally the members of the whole complex group, the institution, town, city, or nation, may organize under the name of the group for intergroup, interinstitutional, or international contests with other groups. The conditions affecting the development of athletics in these various groups differ. Many of the tendencies to evil grow with progress from the simpler to the more complex forms of organization. Under simple conditions the managerial function is undifferentiated. With the development of athletics in formal organization the managerial function arises as a distinct special force.

Athletics, like all games, are passed on by tradition — by imitation and by the older and experienced teaching the younger and inexperienced. As athletics progress in formal organization, the instructional function tends to be differentiated and specialized, and the instructor or coach develops, with special powers for good or evil.

CREATIVE FORCES IN ATHLETICS. — All the various forms of athletics are created and all the different tendencies in development are determined by two different classes of interests in contests common to all men: the participant's or contestant's impulses, pleasures, and interests in the activities and result of the contest, and the spectator's impulses, pleasures, and interests in the contest and its results as a spectacle.

The Contestant's Incentives. — The contestant's pleasures and interests develop out of a series of play tendencies which must be understood to understand athletics. At the foundation of all vigorous muscular play there is a pleasure in the

mere motor discharge exhibited by the young of all animals — a satisfaction of the primitive hunger for activity. To these fundamental pleasures there are added a long series of pleasurable emotional states. There is the conflict of daring and fear in feats, the pleasure in accomplishment and success, the pleasure and pride in overcoming difficulties and encountering risk or danger with all its emotional tension, the exaltation that comes in the rebound from fear, from the tension of expectation, and from the shock of surprise, the pleasure of enduring hardships and suppressing pain, the pleasure in mastery of self, the inspiration of being a cause, and all the emotional content which holds attention and heightens the reality of life, which is opposed to ennui, and which for the adolescent is a neurological necessity. Then there are the impulses which influence the form of play. Through all childhood there is intense pleasure in being chased and chasing, hiding, being sought and seeking. The combative social and egoistic impulses, appearing in play from early childhood, become especially prominent with adolescence. Simple running for its own sake soon loses its charm and must be turned into a contest, thus satisfying the combative impulse. Rolling about on the floor is turned into a tussle. The egoistic impulse combines with the combative to give keenness to do something as well as or better than some one else. This tendency becomes peculiarly strong in the adolescent period, the athletic age.

The social impulses, with perhaps some sexual elements, add their force. A desire for social applause and approbation leads often to self-exhibition and a display of skill or courage. Especially keen is the pleasure of achievement in competition under social conditions, perhaps the highest stimulus and satisfaction in youth to the egoistic impulses and emotions. Cravings for self-testings, self-evaluation, the determination of one's social status, become prominent. Where these impulses come in contact with developed or traditional play activities, as in athletics, there arises spontaneously a craving

to gain one's place in the social system, to become a member of the team, to represent one's fellows, to support the honor of the group, and to win the satisfaction and applause of achievement, to gain honor. Public interest intensifies these expressions. To be prominent in social activities is one of the most stimulating of social motives.

Athletics are then the more formal contests among plays and games, limited by set rules and arranged by social usage or agreement to give the largest satisfaction to the combative, egoistic, and social impulses and emotions. The primary incentive in athletics is to secure these pleasures. Uninfluenced from without, there is no other conscious aim than these pleasures. With the development of athletics in social prominence, motives become more and more social, centering in honor. A series of secondary interests and motives arise, such as a desire for social prominence, leadership, or power. Under the stimulus of social applause and the desire for honor, the primary pleasures in the contest may be replaced by discomfort or hardship, or even pain, yet the motive sustains the effort. If to these highly developed motives the desire for material gain is added, the aim becomes professional. How the motives in the individual shall develop is determined by his temperament and the social conditions surrounding him. It is in the soil of specialized social motives, so far as the athlete is concerned, that most of the difficulties in athletics develop.

The nature of the incentives that create play and athletics and the need of vigorous neuromuscular activities during the entire period of growth and development in order to realize bodily powers, reveal the functions and meaning of athletics. Nature made the play impulse the guardian of physical and mental needs. As contests appear with, and are especially characteristic of, the adolescent period, they may fairly be considered the natural vigorous exercise of youth. In this sense they may be interpreted as nature's means of physical education during the adolescent period. The primary motives

in athletics and the normal results are purely educational; the youth's aim in contests is pleasure; nature's aim is education. In these activities, youth has inherent rights, and society is profoundly affected morally and socially by neglect or protection of these rights. The place of athletics among the social customs of a people and in an educational system must be determined theoretically by the necessary amount of daily vigorous activity required during the successive years of youth to develop complete organic power and fundamental psychomotor skill, by the relative superiority of athletics to any other vigorous activity for moral and social discipline, and by the influence of these activities on the general recreative and social customs of the people.

The Spectator's Incentives. — The spectator's interest in athletics, like the participant's, arises from a deep-seated tendency in human nature. It is closely related to the dramatic interest. The struggles of others excite, fascinate, sway. Through sympathy the spectator enters into the struggle. Especially strong is the excitement in fighting contests. Human nature loves to see a fight. The extremes of emotion aroused are best illustrated by the world's great fighting spectacles: the gladiatorial contest, the chariot race, and the bull fight of earlier times; the horse race, the prize fight, and the professional baseball contest of modern times. The less extreme expressions are seen in the support of traveling acrobats, foot racers, and games not intended for spectators. Out of this primal interest in a struggle, common to all human beings, evolves the spectator.

The nature of the contest that will satisfy different individuals depends on character, intelligence, training, culture, and life conditions. On one side there are those who are satisfied with the pleasures of a skillful contest between gentlemen, on the other those who are satisfied only with a fierce personal, often brutal, combat that reveals and rouses primitive human passions. Between these two extremes are all pleasure seekers

at an athletic contest. In the development of all sports these two classes are ever in opposition. The desires of the one, therefore its influence, are in direct opposition to the other. Neither can be satisfied permanently with what pleases the other. The development of athletics in the group will be according to which element dominates in the creation of public sentiment. In proportion as the extreme spectacle-loving element can make its desires felt, will the anti-social tendencies, revealed in the destruction of many sports in the past, reappear. The human tendencies exhibited in the more or less extinct or disgraced contests of the past are still active, and reveal themselves in athletics to-day as in older times.

Many characters are not satisfied with the emotions connected with the spectacle alone. They must play with the emotions of chance and intensify the pleasures in the spectacle by a wager on the result, hence gambling becomes associated with the contest. Furthermore, many live over an emotional reverberation of the contest after it is finished, thus developing athletic gossip and the sporting sheet in newspapers, which in turn arouses the same tendencies in others.

The spectator everywhere tends to take sides and become a partisan. With the development of athletics, the organization of intergroup contests, and the selection of a team to represent the group, partisan athletics arise; the spectator becomes an institutional partisan and takes on a new power for influence. Social pride, clannishness, rivalry, and all the emotions exhibited by a group in competition with another group, surround the contest. Group becomes arrayed against group. The contest tends to take on the characteristics of group war. Public interest becomes partisan, and the partisan aim becomes the dominant aim. Interest centers in the emotions connected with the chances of winning, and shifts to an emphasis on results. Partisan demonstrations add to the spectacle, which attracts an ever-widening circle of spectators.

The influence of the spectator on the more complex development of athletics has been profound. The spectator's pleasure in the skilled exhibition or contest, and his willingness to pay for the pleasure, added to the economic needs of some skillful performers, have created the professional athlete and professional athletics. The professional makes a business of training and developing personal skill to supply a social demand for amusement. His activities can no longer be classified as play. Again the spectator, as indicated in the social elements of the contestant's incentives, supplies the more stimulating applause, approbation, and honors, and, as his interest centers on the more exciting contests and the most skilled athletes, he tends to mold the athlete's motives and the form of his activities. The athlete's motives and the spectator's interests tend to complement each other. This tendency is particularly conspicuous in intergroup partisan athletics. The susceptibilities of different individuals to the influences of the spectator vary greatly, but the combination of the specialized social motives in some athletes and the spectator's desires tends to the development of a form of specialized, highly skilled athletics primarily for the amusement of the spectator. The athlete requires special training, thus emphasizing the coaching function; the spectator's interests require management, thus emphasizing the managerial function. Therefore the influence of the spectator, while a stimulating, though unessential force in the development of athletics, tends toward a narrow, highly skilled form of athletics rather than toward a widening sway of the athletic interest as an educational force. Hence, the spectator and his influence are the most serious problem in the advancing power of athletics.

EVILS OF ATHLETICS. — A number of evils are associated with athletic activities, but a distinction should be made between elemental tendencies to evil and the exaggerated complications of these evils through specific influences in the development of athletics.

1. There is the tendency, associated with all vigorous activities, to physical injury. This tendency is increased by an individual's competing in activities for which he is unfitted, inadequately trained, or improperly equipped, or against individuals out of his class, or while fatigued, etc. The tendency may be minimized by proper inspection, classification, and training.

2. There is the tendency, associated with many pleasurable activities, to over-indulgence which results in physical harm and a dissipation of time. This is chiefly a product of ill-advised enthusiasm, and is exaggerated by the pressure of partisan rivalry. It is eliminated by competent supervision or leadership.

3. There is the tendency to specialization which may result in unbalanced development and unfortunate play habits. It is exaggerated artificially by the pressure of partisan rivalry in intergroup competition. It may be eliminated by competent supervision.

4. There is the tendency, common to all social competition, to bad manners, to irritability in defeat and gloating in victory, though individuals differ greatly in these tendencies. The tendency is exaggerated by bad play traditions in the group, by bad leadership, by disrespect for rivals, by bad treatment on the part of rivals, and by the pressure of partisans. It may be controlled by strong leadership in building wholesome play standards, and by good management, instruction, and discipline.

5. There is a tendency to evasions of the rules of the game. The rules are articles of agreement under which a trial of skill is to be made, violations of which are dishonest. The limitations of the rules offer temptations which test character and training. The tendency is exaggerated by bad play traditions, by vicious instructions from coaches, by suspicion of rivals, by partisan pressure to win, etc. The tendency may be controlled by strong leadership in the development of sentiment

among athletes and by an administration that counteracts the influence of the spectator.

6. There is a tendency to violations of the principles of classification in any group which under the law of participation narrows participation. This tendency is seen under simple conditions and in small groups where the older, stronger, and more aggressive eliminate the younger, weaker, or timid from certain games. It is seen under complex conditions in large groups where there is a temptation to neglect players less skilled than the few best or to use players not legitimately members of the group. The tendency to violate an accepted classification and thus to gain an advantage is strikingly exaggerated through the pressure of partisan rivalry, the interests of the professional coach, and suspicion of rivals in intergroup contests. This tendency may be minimized by educational leadership that will control the influence of partisan and coach. Public opinion may here be very effective.

7. There is the tendency for athletics to come under the control of the spectator and develop into specialized intergroup partisan contests, which in turn tends to destroy general participation and the social respect for athletics. This tendency is especially strong in the later years of youth. With the development of intergroup contests, the desire to win tends to become extreme. Group pride is involved, and success coveted as an honor. This intensification of the desire to win and the exaggeration of the importance of winning tend to destroy the character of athletics as play. Training for skill is pushed to the limit of youthful endurance. This, though the discipline may be commended, few individuals are capable of enduring. Exceptional individuals must carry the burden, so there is selected a special group of athletes on which spectators, coaches, and managers focus their attention, leaving the majority of the group forgotten and neglected. Exceptional individuals are scarce, hence partisans search for them, and

proselyting or recruiting methods develop, which promote violations of the laws of classification. Even for the exceptional athlete, play is changed into work, and the maximum energy and time become consumed. As a natural result there arises for some athletes the question: What is there in it? This the partisan tends to meet by extra encouragements, inducements, honors, and rewards, and petty professional practices develop which are perpetuated by custom and the enthusiasm of partisans. The extreme specialized training aggravates the lesser tendencies to evil, to counteract which artificial methods are adopted. Trainers, rubbers, and the training table are employed to meet the physical needs; officials are multiplied to minimize the tendencies to unsocial acts and violations of the rules of the game; and complex eligibility codes are formulated to reduce the tendency to ignore the laws of classification.

Both managerial and instructional functions tend to become totally divorced from the play needs of the masses of youth and to become highly specialized agents of the spectator. The coach, being judged by the results of contests, concentrates his efforts on exceptional athletes. The manager, being dependent on the spectator for finances, tends to manage solely in the interest of the spectator. This management and the expenses connected with the equipment of teams, cost of games and trips, officials, training tables, coaches, trainers, rubbers, doctors' bills, medical supplies, honors, rewards, privileges, etc., tend to surround athletics with a strong commercial atmosphere, unwholesome and destructive to the play spirit. The final tendency of partisan athletics is toward a business, involving a few specialized athletes performing for the satisfaction of partisans, which is essentially professional in methods and commercial in character. Youth tends to lose all sense of athletics as a natural, valuable, and dignified activity, and public opinion tends to consider athletics merely as a spectacle. How far this evolution will proceed in the organ-

ized athletics in any group will depend upon the age of the contestants and the elements to be controlled.

Several factors tend to exaggerate the specializing influence of the spectator. The press associates partisan contests not with educational topics, but with professional baseball, prize fighting, and horse-racing gossip, thus misguiding public opinion. Educators, concentrated on intellectual education, tend to avoid leadership in the outdoor life of youth. They tend to leave managers, coaches, and players without supervision, subject to the domination of partisans, and free to use their own methods. Winning teams have been associated with the advertising movement, especially in colleges, and this leads educators to tolerate unwholesome practices. The same results flow from suspicion of rivals.

Of these several tendencies to evil in athletics, the first three, or the tendencies to physical injury, over-indulgence, and specialization, reduce or destroy the valuable physical results of play; the fourth and fifth, or the tendencies to bad manners and violations of the rules of the game, reduce or destroy the valuable moral results; the sixth and seventh, or the tendencies to violations of the law of classification and to control by spectators, reduces or destroys the educational values of athletics for the many, and the social respect for athletics among serious people.

It is clear that the tendencies to evil increase in seriousness as youth approaches maturity, as the intergroup organization becomes emphasized, and as the partisan spirit develops.

CONTROL OF ATHLETICS. — The importance and the values of athletics in the life of youth, the factors controlling participation, and the tendencies to evil, show a need of administrative authority with larger vision and broader educational powers than are possessed by youth. Experience has shown that the play life of both children and youth must be supervised, if the values of play are to be secured and the evils eliminated. This control becomes increasingly important with the advancing

years of youth because the factors tending to eliminate from participation and the tendencies to evil become more influential. The values of athletics are the normal product of the athletic impulse; the evils are the product of the ignorance of youth, social influences beyond its understanding, and the neglect of natural leaders or teachers. Youth is helpless alone to understand or control the factors influencing participation or the factors causing tendencies to evil. Educators or social workers start a reform wave when they realize that neglect has divorced athletic influences from the aims of education, that the masses of youth have lost the habit of and respect for participation, and that public opinion through lack of respect is unfavorable and depressing to the general spirit of play among youth. Attempted reform often precipitates an athletic struggle between the reform interests and the interests in control of the athletics to be reformed. Potentially or actually this struggle exists under all conditions because of the contrast in tendencies between the two primary interests in contests and a corresponding contrast in public opinion. Between the two primary interests a transitional mixture of the two exists which causes most of the struggle. These three interests give three general concepts of what athletics are for and whom they are for, to which all current opinions and attitudes refer and which determine all policies and methods in the administration of athletics. These concepts may be formulated as follows: (1) Athletics are solely for the pleasure of the spectator and the profit of the athlete who furnishes the pleasure. (2) Athletics are primarily for the pleasure of the spectator, especially the partisan sympathizer, and secondarily for the pleasure or honor of the athlete. (3) Athletics are primarily for the benefit of the athlete seeking pleasure and achieving organic and social power, for the fellowship, sympathy, unity, and loyalty among members of the team and (where intergroup teams exist) among the members of the social group which the team represents. If athletics are organized and

administered on the first of these concepts, there arise pure professional athletics, or athletics for the spectator. This concept has its legitimate place; to it, in respectable expressions, there have been no serious objections so long as it keeps its place. If athletics are organized and administered on the third of these concepts, "educational athletics," as defined above, are the result. If athletics are organized and administered on the second of these concepts, there develops a class of athletics somewhere between "educational athletics" and professional athletics, which are seldom truly educational, and more seldom frankly professional. The tendency they take depends upon the class of characters dominant in the control of their organization and administration. In this concept there is nothing that is distinctly independent of the other two. It is a transitional mixture of the two primary interests. In it there is nothing that does not logically belong to the first or the third concept. It is based on misguided notions, half-evolved customs, and incomplete logic.

Again, if the first concept is accepted, the policies will center in one position: "Get the best talent possible" and satisfy the spectators. If the second concept is accepted, the desires of partisans and anxiety concerning questions of material for winning teams will be paramount in the development of administrative policies, always with an exaggeration of tendencies to evil. If the third concept is accepted, the only position that can be taken is: athletics are for the education of all youth, irrespective of athletic skill or ability to make pleasure for spectators, bring "honor" to a group, or satisfy the pride of partisans. This concept and its interpretation does not necessarily abolish pleasure for the spectator, nor the possibilities of his education as a spectator, but it determines absolutely the primary point of view in the creation of administrative policies and methods. It determines the relative amount of time that should be devoted to vigorous muscular activities as compared with other educational activities, the

obligations of institutions to furnish opportunities for participation by all and instruction for all, the organization of activities to meet all needs and capacities and to conserve primarily the interests of the many, the attitude on violations of the law of classification, recruiting and uneducational methods of developing teams, the supervision of the conduct of athletes in games, in training quarters, and on trips, the character and number of games played, the character of instructors and managers, the financial methods, the kind of training methods, such as training tables, trainers, and supplies, the attitude in inter-institutional relationships, etc.

An effective control depends on public opinion and expert educational leadership. Effective leadership will be hampered by an unintelligent, careless, or vicious public opinion; public opinion, even educationally the best, can be effective only through technical leadership. Educational athletics for all can be fully realized only when the public sees clearly the distinction between athletics as an educational force in the life of youth and athletics as an amusement for the public, until it respects athletics as an essential element in the education of youth, fosters a spirit of competitive play, and supports an educational administration. Public opinion will take this position only when educational leaders see and cultivate this viewpoint. Effective leadership requires technical skill, knowledge, authority, and character to secure the participation of all and to avoid the evil tendencies.

To secure effective participation an educational administration must do three things: (1) It must supply opportunities in the form of equipment and activities that will meet the capacities, needs, and tastes of all. (2) It must supply for all instructors who are primarily interested in the education of youth, who are trained to recognize individual capacities, needs, and tastes, and who will give sympathetic leadership, encouragement, and stimulus, especially to the less fortunate, in the development of effective play habits. (3) It must

supply an organization that is primarily concerned in conserving the educational rights of youth in athletics, that will inspire respect, and that will maintain a fair classification for competition.

To avoid the evil tendencies an educational administration must also supply three additional influences. (1) It must supply the technical knowledge and skill to give physical examinations, supervise the amount and character of activities, and care for minor injuries, thus avoiding the tendencies to evils that destroy physical results. (2) It must supply a moral leadership with knowledge and skill and character-power sufficient to control bad manners and tendencies to violations of the rules of the games and all tendencies that destroy moral results. (3) It must supply a social leadership with educational ideals, independent character, and honesty sufficient both to lead the earnest, honest, and reasonable spectators and to control or ignore the narrow or selfish partisan in all tendencies to violations of the law of classification, the educational viewpoint, and the social status of athletics.

All these requirements in an efficient educational leadership demand specialists trained as educators in the use of vigorous play activities as educational subject matter.

ATHLETICS IN SECONDARY SCHOOLS. **Stages of Development.** — Athletics for high school boys seem to be passing through three distinct stages as regards the attitude of the school authorities: first, opposition; second, toleration; third, coöperation. It is not many years since school authorities looked upon athletics as a positive evil, and not only refused to allow the schoolboys to take part, as representing the schools, but absolutely opposed such activities. After a time they began to realize that boys were sure to engage in athletics, whether the school authorities gave their permission or not, and a period of toleration followed. The result was that teams competing under the school name frequently brought discredit upon the school

and caused principals and teachers considerable annoyance. The difficulties were practically solved when the teachers took hold with the boys and helped to organize the sports and to provide the necessary accommodations.

Organized Athletics. — The problem of control has been made difficult through neglect, but organized athletics in the elementary school are helping to improve the situation by developing a proper spirit among the boys and bringing them to appreciate the necessity of rules of eligibility and competition. It is reasonable to hope that well-organized athletics in the elementary and high schools of the country will help solve the problems of athletic control in colleges and universities. The coöperation of other athletic associations, as the Amateur Athletic Union, the Military Association, etc., is absolutely necessary in order to enable the school authorities to enforce their authority, and it is usually given. A few test cases bringing home to schoolboys the fact that they can have no standing in other clubs or associations unless they preserve their athletic standing in their school are sufficient to fix the authority of school officers.

Rules of Eligibility. — The following rules of eligibility are taken from the handbook of the Public Schools Athletic League of New York City.

No high school pupil shall represent his school unless he has attended a school for twenty school weeks, unless

(a) He has been promoted from an elementary school, whereupon he shall be eligible immediately;

(b) He has been admitted from a school outside the New York public schools, whereupon he shall be eligible after an attendance of twenty school days.

No high school pupil who has reached the age of twenty-one shall be eligible to represent his school in any branch of athletics.

A boy shall be eligible to represent his school in athletics during any "marking" interval who has placed 14 hours

(13 hours) of prepared work to his credit at the last rating in the office records.

In those high schools where physical training is not conducted according to the syllabus 13 hours, instead of 14, shall be considered as constituting eligibility.

Drawing and shopwork in manual training schools shall count one hour for two.

Any extraordinary case shall be submitted to the High Schools Games Committee.

A graduate of a three years' course in the high schools who returns to take up postgraduate work is permitted to take part in athletics, providing he is eligible according to the rules of the Public Schools Athletic League.

No pupil who is a graduate of a four-year secondary school course shall be eligible to represent any school.

Only those pupils who are taking full work in a regular course shall be eligible to represent the school.

No pupil shall be allowed to compete in the mile run unless he has reached the age of sixteen years and six months. No pupil shall be allowed to compete in the junior events if he is sixteen years old or older. A birth certificate shall be accepted as proof of a high school junior's age. If such certificate cannot be secured, other evidence may be submitted to the High Schools Games Committee.

Any boy who has matriculated in any college or who has played on a college team shall not be eligible to represent a high school.

No entry shall be accepted unless countersigned by the principal or the school's representative on the High Schools Games Committee.

Any high school pupil known to have bet or acted as an agent for others in betting on athletic contests shall be debarred from competition for one year.

Safeguards. — In the secondary schools the events are graded on a plan similar to that in the elementary schools, and a limit is placed upon the number of events in which a boy may enter. All boys taking part in the interschool competitions are required to present a certificate signed by a reliable

physician stating that they are physically able to participate. Effort is made to eliminate from the list of events those that present any danger of serious injury to the participants. As an example of this, football under college rules has been discouraged by the League. In New York City soccer football is played as a substitute. The game of soccer is free from the dangers of mass plays and tackles, and offers an opportunity for all boys to take part. The small boy has an equal chance with the larger fellows. In fact, he is frequently able to outplay his bulky opponent.

Events. — The generally accepted events for secondary schoolboys are: 100-yard dash, 220-yard run, 440-yard run, 880-yard run, 1-mile run, 100-yard hurdles, 120-yard hurdles, 220-yard hurdles, half-mile and mile relays, running broad jump, running high jump, pole vaulting, putting 12-pound shot, discus throw, basketball, baseball, soccer football, cross-country running, tennis, swimming, skating, marksmanship.

Summary of Values. — Among the objections that are raised against athletics for schoolboys are the following: overstrain, unfair tactics, too much publicity, and too much time and attention. On the other side there are positive advantages of well-organized athletics, such as the development of courage, decision, alertness, tenacity, resource, obedience, restraint, fairness, coöperation, self-sacrifice, and generalship. The outlook is exceedingly hopeful because the advantages so manifestly outweigh the disadvantages, and because under a well-organized system the evils may be practically eliminated.

Summary of Effects upon the School. — The leading consideration in athletics for school children must always be that of the effects upon the school. In cities where this work has been organized and given a fair test, school authorities are practically unanimous that: (1) Class work is better. (2) The health of the school children is improved. (3) A wholesome school spirit is developed. (4) There is less trouble about

discipline, owing to the closer relation and better understanding between the pupils and teachers. A district superintendent in the New York City schools recently declared at a public meeting that organized athletics had done more to break up truancy in his district than any other thing that had been tried. The following quotation from a letter written to the Secretary of the New York City League by a school principal is typical of the attitude of teachers, principals, and superintendents. "Permit me to add a word of commendation to the many you have received, for the excellent work your association is doing toward developing a love in our public schoolboys for clean athletics. These sports, I believe, improve our boys, not only physically, but also mentally and morally. This conclusion has been the result of my personal observations extending over about four years. I have known of many cases where boys who had previously been quite neglectful of both studies and conduct in their classes, showed marked improvement in both lines after entering into athletic contests. I have yet to find the boy who has done poorer work at school because of these sports. Many times the leaders in athletics have also been the leaders of their class in their studies."

Athletic Courtesy. — One of the benefits of organized athletics for schoolboys is the opportunity that is afforded for practicing those manly virtues that mean so much for success in after life. One public school athletic league prints in its handbook the following standards, and emphasizes them to the boys as the ideal in athletic competitions: (1) The rules of games are to be regarded as mutual agreements, the spirit or letter of which one should no sooner try to evade or break than one would any other agreement between gentlemen. The stealing of advantage in sport is to be regarded in the same way as stealing of any other kind. (2) Visiting teams are to be honored guests of the home team, and all their mutual relationships are to be governed by the spirit

which is understood to guide in such relationships. (3) No action is to be taken nor course of conduct pursued which would seem ungentlemanly or dishonorable if known to one's opponent or the public. (4) No advantages are to be sought over others, except those in which the game is understood to show superiority. (5) Officers and opponents are to be regarded and treated as honest in intention. When opponents are evidently not gentlemen, and officers manifestly dishonest or incompetent, future relationships with them may be avoided. (6) Decisions of officials are to be abided by, even when they seem unfair. (7) Ungentlemanly or unfair means are not to be used, even when they are used by opponents. (8) Good points in others should be appreciated and suitable recognition given.

TOPICS FOR FURTHER STUDY

1. What are the relative merits of athletics as compared with gymnastics for physical education? For moral education? For social education? Which contributes most to the school? Study these in reference to particular schools.

2. What is the best type of organization of athletics in schools or in a given school? What are the merits and demerits of such plan of organization, — individual groups, permanent associations, institutional groups, or interscholastic associations?

3. What are the dangers of professional athletics in our high schools? In what forms does professionalism seek to come in?

4. To what extent should athletics for spectators be allowed to influence?

5. What are the forms taken by this demand of the spectators or of the public?

6. In what ways is the influence of the alumni in athletics exerted in a given school? Which of these influences are good? Which bad?

7. What can American schools learn from English schools in the matter of athletics?

8. What are the evils of athletics as seen in any given school? The benefits?

9. Through what stages of development have athletics passed in any given school? What actual growth in principle is observable?

10. To what extent should coöperation with other athletic organizations be permitted or encouraged?

11. How can school athletics be used to promote public manners as well as public morals?

REFERENCES

General:

- JOHNSON, GEORGE E. *Education by Plays and Games*, with Bibliography. Boston, 1907.
- LELAND, ARTHUR, and LORNA, H. *Playground Technique and Playcraft*, with Bibliography. Springfield, 1909.
- MCCURDY, J. H. *Bibliography of Physical Training*. See p. 9, group 013, Philosophy: Relationships, which gives the best references up to 1905. Springfield, 1905.
- MERO, E. B. *American Playgrounds*, with Bibliography. Boston, 1908. *Official Handbook* of the Athletic League of the Young Men's Christian Association of North America. American Sports Publishing Co., New York.
- Official Handbook* of the Public Schools Athletic League, published yearly since 1904. American Sports Publishing Co., New York.
- Official Handbook* of Sunday School Athletic League of Brooklyn, New York. The Walden Press, 64 Fulton Street, New York.
- Playground Association of America. *Proceedings* of Annual Playground Congress, 1908, 1909. New York.
- Proceedings of the Athletic Research Society. *American Physical Education Review*, Vol. XV, Nos. 3 and 4. March and April, 1910.
- Proceedings of Intercollegiate Athletic Association of the United States. Published yearly since 1906. (These papers are the best on college athletics, and all are published in the *American Physical Education Review*.)
- Reports and Proceedings* of Athletic League of Baltimore, 1909.
- Report of Committee on An Amateur Law. *American Physical Education Review*, Vol. XV, No. 3. March, 1910.
- Year Book* of the Public Schools Athletic League of the City of New York. Published since 1905.

Public School Athletics:

- BISHOP, E. C. How Should the Athletics of the Y. M. C. A. supplement that of the Public School. *Hygiene and Physical Education*, Vol. I, No. 10, p. 880. Springfield, Mass.
- CLINE, EARLE. The Advisability of Inter-High School Contests in

Athletics. *Physical Education Review*, Vol. XV, No. 1, p. 22. Springfield, Mass.

Handbooks of the Public Schools Athletic Leagues of Baltimore, Md., Buffalo, N. Y., Newark, N. J., New Orleans, La., New York, N. Y., Seattle, Wash. (These will be sent free on application.)

LARNED, C. W. Athletics from Historical and Educational Standpoint, *Physical Education Review*, Vol. XIV, No. 1, p. 1. Springfield, Mass.

MEANWELL, W. E. The Team Game Tournament. *Hygiene and Physical Education*, Vol. I, No. 9, p. 896. Springfield, Mass.

NICHOLS, E. H. Competitive Athletics. *Physical Education Review*, Vol. XIV, No. 9, p. 589. Springfield, Mass.

Report of the Committee on Athletics for Boys and Athletics for Girls of the Playground Association of America, 1 Madison Avenue, New York City. (Sent free on application.)

Pamphlet on Public Schools Athletics. Department of Child Hygiene of the Russell Sage Foundation, 1 Madison Avenue, New York City. (Sent free on application.)

CHAPTER XX

SOCIAL ASPECTS OF HIGH SCHOOL EDUCATION

THE SOCIAL VIEWPOINT. — In the light of present knowledge it is evident that education, even in its most naïve form, has always had a social bearing. The earliest groupings of persons for the sake of learning were in themselves social activities, and even though the intellectual or other gains thus made were desired entirely for individual ends they nevertheless had consequences for society as a whole. But previous to the nineteenth century¹ the value of education other than that to the individual had little place in human thinking. With the perfection of the processes for dispersing knowledge, however, there occurred a profound deepening of social self-consciousness. Society began to understand the secrets of its own development and to manipulate with a confidence never before possessed the various forces and conditions that determine social progress. One of the most important manifestations of its new ability took the form of self-government. Having been made possible by the spread of learning, it was inevitable that democracy should include the promotion and administration of education among its own obligations, to be fulfilled henceforth as a rigorous measure of self-preservation.

The perpetuation of popular government is, however, only one phase of modern educational utility. Society looks to the school for richness and beauty of existence as well as for safety. The transference of accumulated knowledge to rising generations; the cultivation of sensibility to, and proficiency in, the arts; preparation for economic life; protection against

¹ See Paul Monroe, *Influence of the Growing Perception of Human Inter-relationship on Education*, *Proc. Am. Sociological Society*, Vol. VII, p. 47.

disease; and the physical development of the species, — these constitute only a partial list of the services now being exacted, but they well illustrate the more obvious form of the social viewpoint — the school as an instrumentality of society. The changes, tendencies, and considerations which have arisen in public education in response to the demands of society have been called its external social aspects.¹

INTERNAL VIEWPOINT. — Modern developments in social psychology, anthropology, and the social sciences in general have greatly increased our knowledge of the laws governing the educative process. Intellectual growth, it has been discovered, is largely conditioned by the contacts of the individual with other individuals. In the approbation of the group lies a powerful incentive to achievements in learning. The microcosmic character of the school itself gives it capacities for training which, if properly utilized, yield important cultural results. The innate tendencies on the part of the young to initiate social organization have been revealed as allies ready for employment in the exercises preparatory to citizenship. Many generalizations of equal educational import have been formulated by sociology and genetic psychology during the last few decades. The modifications and problems which they have occasioned may be called the internal social aspects of education.

Ever since the school became an agency of society it has changed with the changes in the objects it was designed to serve. These modifications have been multiplied, not only by the urgency of successive social needs, but also by the perception of the new educational ways of meeting them which have been revealed by social psychology and its allied sciences. So that to-day the school finds itself at the confluence of two streams of influence: the demand of an extraordinarily complex social situation and the suggestions emanating from a rich mass of scientific data. The phases of education they

¹ See Irving King, *Social Aspects of Education*.

turn into view are vast in number, but for purposes of discussion they may be conveniently grouped under the following heads: (1) content of instruction, (2) methods, (3) organization, and (4) supplementary, or extension, activities.

CONTENT OF INSTRUCTION. — The social demand being made upon the secondary curriculum, in obedience to which it is undergoing rapid modification, is that it shall contain material preparatory for *all* — not as in the past for a few — of the actual relations which its students will sustain in after life. Thus to the traditional groundwork for professional careers are added the fundamentals of many other callings. Indeed, so strong has the demand for vocational education been that special schools giving a technical training in all the leading commercial and industrial occupations, including agriculture, are now to be found in the secondary field, while in the general high school it is seldom that the academic course is not accompanied by courses in bookkeeping, stenography, manual training, and the domestic arts.

Besides the insistence upon a vocational preparation, society is calling for a more adequate fitting of young people for the obligations of citizenship. Hence economics, civics, and socialized historical courses now find place in the most complete curricula. The importance to the community of good health has added emphasis to physiology and chemistry and helped to bring courses in physical training and personal hygiene into the body of secondary instruction. The vice-preventing and character-forming qualities of proper recreation have made athletics a matter of conscious control by faculty and students, while the finer potentialities of well-used leisure are recognized in the elaboration of the fine arts courses and the requirement, increasingly made, that whatever is cultural in the curriculum shall be actually realizable in the student's probable future environment.

Finally, as has been pointed out in Chapter I, society is now demanding for its own sake that secondary education be so

specialized and so adapted to personal variations that the particular aptitudes of individuals, whether for social leadership, economic production, or any other kind of human activity, shall through it reach the fullest development that is feasible within the limits of time and circumstance.

SOCIALIZED METHODS. — With a growing emphasis upon an education “ related to life ” it is natural that its processes should more and more be surrounded with the same conditions as those which envelop the affairs for which the educands are being prepared. Thus in the industrial courses there is a tendency to have the pupils make products having a commercial or real value under conditions as far as possible like those existing in the manufacturing world. Repairs are made on real school or home furniture. Plans are drawn for buildings which are actually to be erected. Periodicals are printed which serve as bona fide mediums of intelligence; designs are contrived which will ornament actual pages, book covers, or wall papers. Thus in all vocational courses there is a disposition to take advantage of the stimulus which comes from a genuine need felt by the student and filled by the products of his own hands, a pedagogical situation that is much more exciting than that afforded by an artificial problem and an academic solution.

In the teaching of science a similar relatedness to the students' familiar environment is obtained by basing the laboratory exercises upon analysis of everyday foods, the piping of city water, the disposal of sewage, or the home applications of the electric current. In the domestic arts the pupils are more and more given the kind of equipment they will use in their homes and allowed to learn how to furnish and decorate a real suite instead of being drilled in formal prescriptions about a hypothetical one. The languages, ancient as well as modern, are early made the means of classroom communication, and the niceties of the mother tongue are self-taught by literary societies and newspaper competitions. The rudiments

of finance and the practice of thrift are naturally inculcated by student-managed banks having connections with solid outside institutions. Historical facts are dug out by self-governing groups using early documents, evaluating evidence, and re-incarnating the past situations with fresh lineaments drawn by their own imaginations. Civics, politics, social ethics, — these also are self-developed with the aid of newspaper and magazine accounts of current happenings in the students' own ward, municipality, or state, while practice in handling the new conclusions and applying the homemade standards, as well as a familiarity with governmental machinery, are obtained by means of miniature legislatures or congresses sitting in the high school auditorium. Reality is given to musical training by granting credit for orchestral work or membership in the student band. These examples do not by any means exhaust the social aspects of modern pedagogy, but they illustrate some of the more palpable methods of utilizing group stimuli and biological grooves in secondary educative processes.

SOCIAL ELEMENT IN ORGANIZATION. — This comes primarily through the recognition by principal, teachers, and students that they constitute a social organization and that merely through membership and participation in its activities pupils derive a certain kind of training for the larger outside social relationships. If the consciousness of these social aspects have its logical effects, it will perceptibly modify the government of the school. Without surrendering his final authority the principal will give both the staff and the student body a share in the management of affairs and thus secure full loyalty and at the same time impart the important educational effects of self-government. Common expressions of this principle are observed in the various forms of student government, student management of athletics, and the honor system at the time of examinations.

Another phase of this subject is disclosed in the constructive attitude now appearing in high school administration toward

“student activities” and student organizations. It is perceived that through these spontaneous groupings pupils may receive a preparation for after life of a kind which the school has not in the past given, but which is now more and more expected from it. A social training, in the more restricted sense, is a factor in success; and the young person whose home life has not afforded it and who passes through the secondary school without receiving it, is seriously handicapped in his future endeavors. To meet this need principals and teachers are now devising methods whereby student societies may be directed, kept in their proper place, and all their legitimate usefulness may have the widest enjoyment. This policy goes to the extent in some quarters of giving credit towards graduation requirements for exceptional proficiency in social leadership, student journalism, or the management of an organization.

Concern for the pupil's future economic relationship has led to increasing attention to the subject of employment and vocational guidance. While the methods for performing the latter function have not been successfully formulated as yet, the school is feeling such a responsibility in the matter that it is now recognized as a genuine administrative problem. Employment bureaus are found in many high schools.

The new viewpoint in instruction has occasioned organization changes of a novel character. These are the connections existing between certain schools and local industries, commercial societies, or municipal departments. Whether the activity is that of making products of market value, taking an industrial census, or protecting the city water supply, the object is the same, to subject the student to the powerful stimuli of the natural social environment. How far this tendency will go no one can prophesy, but that it is just now a very real one is indisputable. It has also the reënforcement of the vitalizing effect which is wrought upon the teacher's influence through his participation in the concrete activities of the outside world.

Another organic change is that which inevitably follows the principal's perception of his school as a social undertaking that is amenable to the dictates of public opinion. When he realizes that the financial support of his institution depends upon the taxpayer's approval, he begins to seek some certain means of retaining popular approbation. When he appreciates how easily the results of his efforts to mold the habits of his pupils can be offset by the hostile conditions outside of the school, he begins to plan for sympathetic coöperation between his institution and the home and the other constructive forces of the community. As a result more direct connections are established between the high school and the adult members of its constituency. These frequently take the form of parent-teacher, fathers', or improvement associations. By means of them the school staff and the citizens are brought into immediate contact, and the interchange of ideas, sentiments, wishes, and plans between them is greatly facilitated.

HIGH SCHOOL EXTENSION. — The activities under this head find their *raison d'être* in two main sets of conditions: (a) the school's need, for the sake of the completest discharge of its primary function, of more direct connections with society, and (b) society's need of new and larger services from the school. The first of these has already been broached in the preceding section, and regarding it there remains to point out only the consideration that the opportunity for its full satisfaction is afforded in the discharge of the new responsibilities being laid upon the school by society. Thus the most effective way of justifying the huge expenditures of public funds now being made upon high school plants is to utilize them to their fullest possible capacity. To do that requires the bringing in of additional groups of people to be benefited in some way by the school facilities. Keeping the school policy in harmony with public sentiment can best be accomplished by allowing and stimulating popular utterances within school halls. The public can best be informed about school conditions by being

brought into the building where they can be seen. The school staff can be kept in vitalizing contact with social problems by engaging directly in the enterprises that are set in motion to solve social difficulties; and, finally, the school will experience less trouble in securing the coöperation of patrons in the carrying of school ideals, practices, and regulations into the pupils' homes if, in return, the school will facilitate through the loan of its assembly rooms and other resources the attainment of patrons' ends in the other phases of the community life.

SUPPLEMENTARY ACTIVITIES DEMANDED BY SOCIETY. — At the outset it may be said that in putting forth the following demands society's attitude is strongly reënforced by the consciousness of the vast investment represented by secondary school property and of its incomplete utilization when devoted solely to its primary function. In keeping with the prevalent inclination towards the conservation and economical exploitation of all its resources, society makes its growing demands with confidence, and the trend of present developments in the wider use of the high school buildings shows that it is not a mistaken feeling. These demands when classified upon the basis of their dominant effect fall into three classes: (1) moral, (2) cultural, and (3) civic.

1. The comparatively recent discovery of the significance of leisure-time activities in the determination of character has been followed by a public movement to safeguard youth through a constructive surveillance over the periods of play and recreation. Translated into specific high school measures this means the appropriation by young people in general of the gymnasium for basket ball, folk and social dancing, calisthenics, and other physical activities during the marginal periods of day and evening. In the same way the auditorium, with its stage, organ, curtain, and other appurtenances, is requisitioned for motion pictures, amateur theatricals, concerts, debates, and popular entertainments of all kinds. In this

room, as well as other suitable quarters, choral societies, amateur orchestras and bands, social, literary, and debating societies, and social clubs of all sorts carry on their respective activities, while in the laboratories and other workshops those who find recreation through hobbies find means and opportunities which are not available elsewhere.

The inevitable result of any prolonged and systematic attempt to enrich people's recreations is a marked and wide stimulation of individual talent. Entertainments demand entertainers. Performances require performers. The keenest enjoyments known to human beings are always related to the activities of other human beings. Where the enchainment of the attention is desired, somebody's special abilities are always called into play. Accordingly it is quite understandable why dramatic, orchestral, and wind instrument performances find so large a place in recreational programs, why out of playgrounds and social centers play festivals and pageants are now proceeding, and why finally this aspect of the subject makes such a natural transition to the next topic, the cultural effects.

2. The constant craving for knowledge of the best things which have been written, composed, or depicted, that is found in every community may be fed by the high school in a variety of ways. The most common is that of arranging popular lectures, readings, and concerts and by the provision of evening courses in literature, the foreign languages, and art appreciation. Some schools offer also the privileges of a public circulating library, but the most striking example of this kind of service is to be found in devotion of the lobby, corridors, or some specially designed space to the uses of an art gallery. In the instances already existing, loan collections, artists' exhibitions, the stored-away surplus of the local museum, and the treasures assembled by art societies have formed the material for undertakings which are as stimulative to the students as they are productive of enjoyment and cultivation for the community. *Æsthetic* resources are also increased through

the encouragement involved in the letting of rooms for meetings or rehearsals to musical, literary, or art societies and organizations. Not only the amateurs, but the professional performers and teachers, are benefited by every increase in the opportunities and occasions for attention to the things that delight the eye, the ear, and the spirit.

3. The opportunities for aiding the civic life of a community that are open to the high school arise (a) partly from the manner in which our institutions are being modified, and (b) partly from the intellectual and spiritual needs of a people not all equally qualified for bearing the responsibilities of a democracy.

(a) The alterations, improvements, recastings of municipal, state, and national machinery are usually made, in the first instance, by groups of specially interested individuals generically called voluntary organizations. Bodies of this type not only devise the new perfections but also undertake to bring about their adoption, and oftentimes maintain the new activity, for demonstrative purposes, until society is ready to incorporate it in the regular governmental routine. The existence, efforts, and efficiency of such organizations can usually be greatly furthered by the provision of quarters for meeting and working. This service high schools are increasingly performing for all sorts of welfare and improvement associations and institutions.

(b) Ignorance of local civic affairs may be due to foreign birth or parentage. This defect high schools can aid in remedying by offering courses in English, and by giving to foreigners in other ways knowledge of our customs, history, and institutions. The dignity of American citizenship is being impressed upon newly naturalized immigrants in some schools by special occasions presided over by leading citizens and surrounded with suitable ceremonies. The familiarity with civic affairs which is usually so inadequate among the generality of people can be improved through the institution of ad-

dresses and discussions by persons of prominence and authority upon topics of governmental import.

Finally, the system of party-promoted political education, now subject to so many abuses, can be greatly elevated and renovated by bringing its occasions into the light and giving them a dignified setting. The use of school auditoriums for political rallies will also tend to lessen the need of campaign contributions and thus cut off some of their train of evils. But more important still, the recognition of this function as an educational responsibility will hasten the time when civic intelligence will be publicly inculcated and not longer be subject to the subversions and distortions incidental to promotion at the hands of selfish and mercenarily biased factions.

In conclusion, the consciousness of social needs and social processes in the direction of secondary education means its approximation in content and method to the life for which it endeavors to prepare its students. Complete identification with life would be a disaster. But getting the full strength of its vital forces behind the ideals brought down from above will bring a wonderful quickening.

TOPICS FOR FURTHER STUDY

1. Enumerate the purely individual aspects of elementary public school instruction. Of secondary education.
2. Contrast expressions of the social motive in early American education laws with those to be found in the recent enactments of Wisconsin, New York, and other states.
3. Make a complete list of the social demands upon public education and distinguish those which apply respectively to elementary and to high schools.
4. Describe briefly the teaching process as it existed among two primitive peoples.
5. State all of the disadvantages you would experience if you undertook to acquire the equivalent of a high school education by yourself; that is, without attending school or having tutors.
6. Rank the various subjects in your curriculum in the order of their importance as preparations for citizenship.

7. Differentiate by means of illustrations the typical learning processes of the classroom and of daily life outside the school.

8. Which do you find more enjoyable, writing an essay that is required in the English course, or a letter of equal length to a friend? Analyze the reasons for your preference.

9. What occasions outside of those connected with the school and the civil service are most similar — in character, not significance — to term examinations?

10. In the case of which subjects in your curriculum could the instruction be organized upon a more coöperative, democratic basis? Which not? Give reasons.

11. Characterize the form of government in the usual classroom. What changes would need to take place to make it democratic?

12. Expound the relation of recreation to morality.

13. Give the reasons for holding political discussions in public school buildings.

14. What is community art?

15. How far does the education law of your state authorize school boards to undertake the various extension activities outlined in the foregoing chapter?

REFERENCES

BLOOMFIELD, MEYER. *The Vocational Guidance of Youth*. Boston, 1911.

BOONE, R. G. Manual Training as a Socializing Factor. *Education*, 22: 395.

DENISON, ELSA. *Helping School Children*. New York, 1912.

DEWEY, JOHN. *School and Society*. Chicago, 1899.

The School as a Social Center. *Elementary School Teacher*, 3: 73.

DUTTON, S. T., and SNEDDEN, D. *Administration of Public Education in the United States*. New York, 1908.

ELLWOOD, C. A. Sociology and Modern Social Problems. Chap. XV of *Education and Social Progress*. New York, 1910.

GRICE, MARY V. *Home and School*. Philadelphia, 1909.

GULICK, LUTHER H. Popular Recreation and Public Morality. *Annals of American Academy of Political and Social Science*, July, 1909.

JENKS, JEREMIAH. *Citizenship and the Schools*. New York, 1906.

JOHNSTON, CHARLES H., and others. *High School Education*. New York, 1912.

The Modern High School. New York, 1914.

KING, IRVING. *Education for Social Efficiency*. New York, 1913.

Social Aspects of Education. New York, 1913.

LEE, JOSEPH. Play as a School of the Citizen. *Charities*, 18: 486-491.

- MONROE, PAUL. Influence of the Growing Perception of Human Inter-relationship on Education. *American Journal of Sociology*, March, 1913, p. 622.
- MOWRY, D. Use of Schoolhouses for Other than School Purposes. *Education*, 29: 92.
- PERRY, CLARENCE A. School as a Social Center, in *Cyclopedia of Education*, Paul Monroe, ed. New York, 1914.
Wider Use of the School Plant. New York, 1910.
- SCOTT, C. A. *Social Education*. Boston, 1908.
- Students' Aid Committee of the High School Teachers' Association of New York City, E. W. Weaver, Chairman. *Choosing a Career*, and other vocational bulletins. 1909.
- Tenth Yearbook* of the National Society for the Study of Education. Part I, "The City School as a Community Center"; Part II, "The Rural School as a Community Center." Edited by the Secretary, S. Chester Parker, University of Chicago. 1911.
- WARD, E. J. Rochester Social Centers. *The Playground Association Proceedings*, 3: 387-395, 1910.
- WARD, E. J., and others. *The Social Center*. New York, 1913.
- Pamphlets of Department of Recreation, Russell Sage Foundation, New York.

CHAPTER XXI.

THE REORGANIZATION OF SECONDARY EDUCATION

THE FORCES PRODUCING THE PRESENT REORGANIZATION IN EDUCATION. — The educational systems of all civilized countries are at present in a state of profound disturbance and transition. As a consequence of the economic and social developments of recent decades, the demands upon education have multiplied and grown more diversified. Increasing knowledge of the fundamental principles of social economy on the one hand and of individual human psychology on the other have had the effect of revealing to us the inadequacy of the aims which now control in education, as well as the uncertain and arbitrary character of the methods usually employed in instructing and training young people.

These changes are, in the last analysis, due to two fundamental causes. The first is the modern political or social demand for universal education as a necessary means in a democratic society. The second is the increasing effort among leaders to found educational practice, so far as may be, on bases of scientific knowledge, rather than on tradition or on practices which have grown to be customary. To the first cause are due the demands for free elementary and higher education; for compulsory school attendance; and for diversification of educational opportunities to fit the differing needs of the various groups of young people, for all of whom society purposes to secure a fair and generous start in life. To the second cause are due modern efforts to enrich educational programs; to ascertain the actual values of the historic subjects and of the methods of study and teaching which have become traditional in schools; to study experimentally the learning pro-

cesses of children and adolescent youth; and to scrutinize the fields of modern social economy with a view to ascertaining what are actually the valid aims of an education which should be purposefully directed towards the attainment of such valuable ends as those embraced under the broader conceptions of physical efficiency, vocational power, good citizenship, and broad personal culture.

THE REORGANIZATION ALREADY ACCOMPLISHED IN SECONDARY EDUCATION. — Within the field of secondary education many important changes in practice and theory have been effected, and others of even greater importance seem to be impending. High schools of general or liberal education have been so widely established as now to be accessible without fee almost everywhere in America. Attendance on these schools has increased during recent decades at a rate several times greater than that of population. Programs of instruction have become more flexible. A few of the historic subjects of study have been reshaped so as to become less formal and perhaps more adapted to contemporary needs. The general conviction has arisen, and has been widely accepted, that the workshop and other commercial agencies no longer give satisfactory vocational training. It may well become a legitimate function of special secondary schools to insure, at least in part, opportunities for specialized vocational teaching. In a number of respects, educational dogmas and traditions hitherto influential in the field of the general theory of secondary education seem to be giving way. There is a growing tendency to demand a more scientific analysis of purposes and methods in secondary schools.

THE REORGANIZATION TO BE ACCOMPLISHED. — In the main, however, the changes which have already taken place in the theory and practice of secondary education have been due to a growing public demand for the provision of more accessible and more varied educational opportunities. Sec-

ondary schools as yet exhibit relatively few modifications of practice due to current demands for, and tendencies toward, more scientific educational theory and methods based upon scientific principles. It is not surprising that this should be so. The two sciences upon which, in the last analysis, scientific educational practice must be based — namely, sociology and psychology — are as yet in only the very early stages of sound development. It is from sociology and its concrete applications in social economy that we must eventually derive our conscious educational aims; and it is upon a well-developed knowledge of psychology that we must ultimately rely for the foundations of method — a term which, as here used, includes not only the actual methods of giving instruction and training, but also the ways and means of organizing the materials wherewith to realize educational aims.

In the meantime, in addition to administrative changes, a great variety of more or less fragmentary empirical studies are in progress whereby the needs of society and the individual are being ascertained, with a view to at least a clearer definition of educational aims than now prevails. On the other hand, experimental work is being done in the direction of discovering more effective methods of teaching. In consequence, some of the traditions of secondary education are being undermined and much conscious effort is being given to more scientific formulation of purposes, ways, and means.

UNIFORMITY IN EXISTING AIMS AND PRACTICES.

— The controlling aims and the prevalent practices of American secondary education, as that has been and still largely is organized, are capable of comparatively simple description, notwithstanding the enormous recent increase in the number of secondary schools. A very great degree of uniformity in training of teachers, textbooks used, organization of classes, methods of instruction followed, and standards to be met, will be found in public high schools from Maine to California and from the northern to the southern boundaries of the

nation. This uniformity is due largely to the fact that the customs and traditions which had become established when public high schools first came into existence have continued in great measure unchanged to the present day. The agency most immediately responsible for this has been the American college. In the college the large majority of high school teachers have been trained. College men have written the majority of texts, and have constituted the controlling influence in committees organized to make special reports dealing with particular phases of secondary school work. The colleges have, through their admission examinations or system of certification, indicated quite definite goals to be reached, especially in those forms of organized knowledge and skill which written examinations can test. But, in fact, the so-called "dominance of the college" has persisted mainly because educators, whether as superintendents or as teachers and principals of secondary schools, have not been disposed or have not been free to discover and formulate more serviceable ends and means than those which they found already fixed in custom and which the college continued to reflect.

We find, therefore, that in nearly all public and private secondary schools in America the direct and controlling purpose is to teach, according to certain accepted methods, historic academic subjects — of which Latin, Greek, German, French, algebra, plane geometry, various phases of history, English, physics, and chemistry are the more prominent. The content actually taught within each subject, as well as the methods employed in instruction and training, have been slowly developed through the imperfectly analyzed and tested experience of many decades, or even centuries. In practice, the "mastery" of these subjects constitutes the controlling aim of all instruction — the mastery, that is, as measured by currently approved tests, such as college admission examinations, the standards of college instructors assigned to inspect secondary schools, etc.

It is alleged, to be sure, with great frequency and insistence, that other and more fundamental aims in reality control in secondary academic education. These are variously described by such general and vague terms as "mental training," "general culture," "formation of character," "development of the historic sense," "mastery of scientific method," "improvement of ability to use English," "development of thinking powers," etc. There is, however, no conclusive evidence that these aims have, in any conscious way, affected either the choice of the material constituting the course of study in each subject, or the methods actually employed in giving instruction in it. What is clear to almost every teacher and supervisor is that the intellectual standards of attainment defined in examination papers, textbooks, and manuals actually serve as indicating aims to be realized and therefore control the formulation of methods of instruction.

RECENT SPECIALIZATION IN HIGH SCHOOLS.—

Besides high schools devoted primarily to the giving of so-called "academic education," we find in recent years, especially in large centers of population, the development of special high schools, or of non-academic departments within general high schools. These have come into existence primarily in response to a public demand for forms of secondary education reflecting more positively the practical or vocational activities of contemporary life. In practice, the schools or departments thus formed—including not only technical or manual arts high schools, but also commercial departments and schools, agricultural schools, etc.—do not actually realize vocational ends except in rare instances. They constitute essentially a new and modern form of general secondary education. The vocational purpose, as judged by the means and methods adopted, is incidental. Their methods of instruction are usually patterned closely after those of general high schools:

Some vocational secondary day schools are now to be

found, both in the industrial and in the commercial field. A very few vocational schools of agriculture and of home making also exist. So few in the aggregate, however, are these vocational schools that one must recognize them as constituting the beginnings of the realization of a new demand, rather than in any large measure the satisfaction of that demand.

FUNDAMENTAL NEED FOR FURTHER ADVANCE IN THE REORGANIZATION OF AIMS. —

In all secondary schools the greatest single necessity and opportunity for reorganization during the next generation will be found in such a formulation and statement of valid aims as will enable these schools to direct their energies more purposefully than hitherto towards the attainment of ends that are demonstrably worth while, and to discover and define the methods by which these aims can be most effectively realized. It should be clear that no scientific educational program can be based permanently upon the mere mastery of certain subjects of study. Such mastery must be regarded, not as an end in itself, but only as a means to other and more fundamental ends, which should gradually become capable of examination, definition, and evaluation.

The probable futility of much of contemporary secondary education is undoubtedly due to the fact that teachers in secondary schools, and to a large extent those who direct these teachers, have accepted as definite and working goals the memorization or other specific form of mastery of certain bodies of highly organized knowledge, as shown in the ability to pass prescribed examinations. When these teachers are asked to explain why it is desirable that the subjects or phases of subjects in which they train their pupils are preferable to other work that might be done, they fall back upon certain ancient vague and general platitudes as to the disciplinary value of studies, the value of the study as a tool in further investigation or study, or the contribution of the study to character formation.

For example, in almost all academic high schools the study of Latin has gradually assumed a fairly definite form. The grammar, text, and composition to be mastered are quite clearly indicated in college entrance requirements, textbooks, committee reports, and the like. The annual examinations in this subject, or the standards of accrediting authorities, serve to indicate to the teacher quite definitely the degree of proficiency which the pupil is expected to attain. The goals which determine the teacher's activities are, therefore, to be expressed in terms of the mastery of this clearly defined body of Latin. When the educational desirability of Latin is questioned, the teacher, shocked by the impertinence or the ignorance shown by the query, falls back upon vague generalizations about the use of such a study as a means of training the mind, or giving increased capacity to use the mother tongue, or opening the doors to richer conceptions of the sources and developments of civilization. But it is now becoming clear that all of these generalizations express only hopes and faiths. They do not in any positive way shape the methods employed in teaching Latin and never have done so; nor has any demonstration been made of the extent to which the study as now pursued actually contributes to their present realization.

Another example can be found in the study of algebra and plane geometry. Even when Latin, in many schools, was placed upon an elective basis, these branches of mathematical study continued to be universally prescribed. It is exceptional to find a high school from which pupils are permitted to graduate without having passed in these two subjects. It is still more exceptional to find colleges admitting students to degree courses unless such students have met certain requirements in algebra and geometry. The content of these subjects has been, for many years, quite definitely outlined. In textbooks, college entrance requirements, and the reports of committees the material which is expected to constitute

these studies will be found mapped out, often in great detail; and here, again, the standards of attainment are indicated with considerable precision in entrance examinations and the requirements of accrediting authorities. Only rarely are teachers called upon to prove the value of these studies, so universally have educators and citizens been induced to accept, without questioning, their validity for educational purposes. The aims of the teachers of these subjects are, therefore, quite definite; but obviously, these aims cannot be described as ultimate, in any true sense. Here, too, when inquiry is pressed, educators generally fall back upon easy generalizations as to the value of these subjects in mental training, as instruments required in further study, etc. — ends which have actually never been worked over and established in any scientific manner.

Similar illustrations may be found in almost all of the so-called “academic” and even in the vocational subjects now taught in secondary schools. What are the actual ends which do control, as contrasted with those which should control, in the teaching of physics, chemistry, and biology? Is there any evidence that the study of history as now pursued in secondary schools contributes in any important degree to genuine educational ends? In American high schools we expend vast sums in the teaching of French and German; what are the results? What objects have we actually in view in teaching these modern languages? Are these objects realized, and to what degree? What modifications of aim are necessary if we are to find aims which are worth while and which are capable of being realized with the resources at our disposal? These and hundreds of similar questions are to be very carefully analyzed in the near future, as the demand for efficient education becomes more insistent and educators assume a more scientific spirit toward the problems involved.

But at the outset one fundamental fact must be accepted:

namely, that a formulation of the ends of secondary education merely in terms of the mastery of subject matter cannot be long held as an efficient basis for the making of programs and the devising of educational methods. Furthermore, we must view with skepticism all attempts to formulate educational aims in terms of vague statements expressive of social worths. These are not only misleading, but they serve no useful purpose in indicating the means and methods by which they are to be realized. Such generalizations nearly always, of course, indicate ends that are worth while; but they serve no more useful purpose than would the general assertion that it is the business of human beings to strive for health, without indicating any of the means by which disease may be remedied and various forms of health and strength conserved.

REORGANIZATION IN METHODS OF TEACHING AND OF PROCEDURE.—In the reorganized secondary education of the future, the general principles upon which teaching practice will be based may be expected to differ greatly from those which have now become customary. So long as methods of teaching are developed more or less unconsciously, it is unavoidable that certain practices should early become stereotyped, and should long continue with the effect of excluding experimental work in the direction of newer and better methods. For example, until recent years verbal memorization as the chief method and test of learning prevailed, almost to the exclusion of every other form. More recently there has been substituted for verbal memorization, drill in question and answer, looking to the analysis and statement of facts as verbally presented in textbooks. There is no insistence that the student shall use the words of the text, but there is constant expectation that he shall describe the facts substantially as presented in the text. Under these conditions, the use of the constructive imagination and an inductive approach to knowledge become practically impossible. In a few subjects, the so-called

“ topical method ” has gained vogue, while in science teaching the introduction of laboratory work has resulted in still another type of method of teaching and study which has now become almost stereotyped.

But methods of systematic teaching and learning are still unscientific, and tend to assume the rigidity of all practices resting mainly upon custom and belief. In the pedagogy of secondary education as thus far organized, there is as yet little recognition of the value and the possibilities of informal or so-called “ natural ” learning.

Owing to the character of the aims and tests now prevailing, methods of teaching are, as stated above, almost invariably shaped to produce the particular results in mastery of organized knowledge which are demanded and which will show in written examinations. This produces, for example, the curious anomaly which we find in the teaching of English literature. It will be readily agreed that the most satisfactory definition we can give of what should be the valid purposes of the secondary school in the teaching of literature is appreciation of the best writings. The methods now employed, however, are such as to put a premium, not upon appreciation, but upon intellectual mastery, usually in the form of memorization of innumerable details, coupled with some ability to analyze texts and to make approved deductions.

But in a reorganized secondary education, suited to an age of science, conscious and purposeful method must ultimately be worked out experimentally in the light of clearly defined aims. The few present and imperfect examples of this are to be found in our systematic attempts to prepare students for examinations, in the teaching of modern languages, and in the teaching of written composition. In these cases, aims, whether valid or not in the better sense, tend to become somewhat clear, and experimental work to find the best methods of realizing them has, in a measure, developed.

But in such subjects as science, history, literature, mathe-

matics, the classical languages, and some of the so-called "practical subjects," where as yet no clearly defined aims exist, it is still impracticable to develop method experimentally. We possess no standards of attainment either in quality or in degree.

EXISTING NEED FOR REORGANIZATION CAN BE UNDERSTOOD ONLY THROUGH A STUDY OF THE EVOLUTION OF EXISTING PRACTICES. — To understand secondary education as it is now organized, we must examine the various stages of its evolution. Its present aims, content, and practices have been necessarily developed in prescientific stages. Most of the subjects of study now found represented at one time ends valuable in themselves. Learners sought teachers in these fields, and men undertook the teaching of these subjects as a profession. Gradually, bodies of organized knowledge were shaped. We know, of course, that Latin and Greek were eagerly studied at one time by persons needing to use them as tools, or for the purpose of gratifying higher forms of intellectual curiosity. The commoner branches of mathematics were introduced into secondary schools largely as fundamental means of preparing for certain occupations. During the nineteenth century the widespread interest in science had the effect of inducing many persons to seek, in the various branches of physical and biological science, either means of gratifying other intellectual interest or instruments that might be used vocationally.

What a few first needed, demanded, and prized, finally became through imitation the demand of the many. Secondary schools found, in these subjects, knowledge well organized for teaching purposes, and the means of holding students to definite tasks. In time, the subjects thus established became ends in themselves, even long after their intrinsic value had disappeared. This process of evolution has given us in large measure, not only the organized subjects as they now stand, but also the well-established methods of teaching them.

CHARACTER OF PROSPECTIVE REORGANIZATION.—

It is probable that such reorganization of secondary education as will take place during the next quarter of a century will be effected in part by modifications and new adaptations of existing subjects, and in part by the development and formulation of new subjects of study and training, perhaps under names not widely used now. Obviously, the most rational way to reorganize secondary education would be to investigate and define, as far as practicable, the fundamental needs of contemporary society and of individuals in that society, and then so to analyze these needs as to discover by what means and methods and to what extent they can be reasonably satisfied through educational activities in schools. An analysis of objectives of this character would give us a basis whereon we could develop experiments with a view to discovering the best methods of teaching. The field for such an analytical study is the larger social economy of the day, coupled with the needs and possibilities of individual development, and finally the actual and potential educational accomplishments of other agencies than schools. In this way could be established finally the specific functions which it should be the obligation of the schools to undertake, and which it should be within their means to carry out.

A complete analysis of the kind here suggested must be the work of many years. Nevertheless, even within the present field of organized experience and with the rapidly increasing scientific knowledge of society, it should be possible to devise in large measure a series of educational aims or ends, which can be made the basis of further study and experimental work. To this end, the analysis given below is submitted as a tentative contribution.

AGENCIES OR INSTITUTIONS CONTRIBUTING TO EDUCATION.— For the purposes of this analysis we may consider the rounded individual whom it is the ultimate aim of society to produce, as manifesting the effects of three

different sets of influences — namely, those due to heredity, those due to nurture (food, shelter, play, etc.), and those due to education (education being here limited to the more or less conscious control by individuals and social agencies of the formation of habits, appreciation, sentiments, knowledge, and ideals).

Education as a means of contributing to the development of the completed individual is effected through many agencies of a more or less purposeful nature. Among these the home, the school, and the church are the most immediately conspicuous. There should be included, also, the workshop (meaning thereby any place where young people are employed in systematic productive activities), the club, the playground, the press, the stage, the library, the police power, and others less clearly differentiated and perhaps less influential.

The relative capacity of the foregoing educational agencies to perform specific and effective educational functions will vary greatly from age to age. The school itself, as well as the library, the police power, the church, the press, and the stage, are later differentiations from the household and larger group activities of earlier times. Vocational education, so far as the vast majority of occupations are concerned, has always been obtained under the conditions of the workshop. Nevertheless, we find that vocational schools were established even centuries ago, to give vocational training in such fields as medicine, law, theology, and war leadership. For these callings the apprenticeship methods previously employed had proved inadequate. More recently, schools have been organized for certain of the commercial callings, and in a few instances for agriculture, and for a few of the trades. The establishment of vocational schools has resulted from a growing recognition of the fact that in many occupational fields the right kind of vocational training, if it is to be had at all, can be obtained only by creating and setting apart special educational agencies for these purposes.

Again, we find that the church as an agency of moral education fails to reach a considerable element in the community. There is a tendency to demand that schools undertake to make up for the deficiency. There is now a disposition to bring the police power, through the juvenile court and the reform school, into close relationship with systematic school education. The library and the school are coming nearer together. There are prospects that stage and press, as educational agencies, will also be influenced by coöperation with schools. Everywhere we find a tendency to enlarge the functions of the school as a specialized educational agency, notwithstanding the fact that to some extent the other agencies, such as the library, the police power, the playground, and the club are also increasing in educational efficiency.

Each of these educational agencies contributes in a special way to final and complete forms of efficiency. The home is concerned fundamentally with the formation of moral habits, and with such primitive cultural factors as the acquisition of vernacular speech, the inheritance of family customs and traditions, etc. The church undertakes primarily to effect the formation of moral ideals and to insure social intelligence in certain quite definite directions. The function of the workshop is found primarily in connection with vocational education. Each one of these agencies may, therefore, be analyzed from the standpoint of its actual or potential contribution to a rounded and complete education.

THE SCHOOL AS THE SPECIAL AGENCY OF EDUCATION. — Because the school is a specialized and derivative institution, it is evident that we may continue this process of analysis to the point where, the possibilities of the other educational agencies having been defined, the essential function of schools in the educational process can be stated and measured. This may properly be described as a residual function. Historically and politically it is cor-

rect to look upon the school as a special agency created primarily by society for the performance of those educational functions which society needs under existing conditions, and which other less specialized educational agencies cannot easily, economically, or effectively perform.

CLASSIFICATION OF THE AIMS AND PROCESSES OF EDUCATION AS DETERMINING ITS REORGANIZATION. — The process of analyzing educational aims and possibilities may be carried further in the direction of organizing into categories the results which education is expected to accomplish. In the light of present knowledge, the four principal categories may be described under the heads of physical education, vocational education, social education, and cultural education. Physical education is here defined as any form of education whose primary and controlling purpose is to establish those habits, to impart that knowledge, and to inculcate the ideals, which make for prolonged physical efficiency. Vocational education is defined as any form of education whose primary and controlling purpose is to fit youths for specific occupations whereby men support themselves in the world of contemporary economic activity. Social education is here defined as any form of education the primary and controlling purpose of which is to affect group activities in accordance with the demands of modern civilized society. Social education includes moral, ethical, political, and a large part of religious education. It is directed toward the formation of the habits, the development of the appreciations, the imparting of the knowledge, and the formation of the ideals that underlie effective participation in group activities, such as those of the home, the state, and society generally. Cultural education is defined as any form of education whose primary and controlling purpose is to develop in the individual intellectual and æsthetic appreciations, tastes, ideals, and interests that make for the refinement of manners and the æsthetic and intellectual develop-

ment which are comprised under the general term "personal culture."

From the point of view of this analysis, it is also obvious that the various agencies of education described above differ as regards the departments of education in which their best results are achieved. For example, we think of the church as being primarily concerned with social education, the workshop with vocational education, the home and the playground with physical education, the library, the press, and the stage with cultural education, etc.

In order, however, to discover goals which shall be of use in framing programs of school education, it is expedient that we continue the process of analysis further, with a view to defining various social utilities (*i.e.* ends that are socially worth while) in a sufficiently concrete and definite form to make possible the use of such clearly perceived goals as guides in the development of educational methods. The following are tentative proposals to this end.

Physical Education.—The ends or objects of physical education, for example, may in part be analyzed into the specific procedures which shall result in: 1. The formation of various groups of personal habits which have demonstrated value in efficient physical well-being. 2. Clearly defined knowledge of certain established principles and practices of hygiene, the possession of which, under ordinary circumstances, will enable the individual to secure healthful living, and to withstand unhygienic conditions and influences. These ends may be further subdivided and treated under such specific heads as "hygiene of nutrition," "hygiene of organs of sight," "hygiene of the teeth," "prevention of bacterial infection," etc. 3. The establishment, by proper educational processes, of ideals of physical well-being. Non-school agencies such as the Boy Scout movement are even now making suggestive and important contributions in this direction. Athletics and gymnastics, properly inspired and

conducted, also have important bearings on the formation of ideals of physical well-being. 4. The physical development, through specific training, of malformed or unformed organs, or the promotion of functional activities by suitable educational exercises. Many of the valid special aims of physical education are already fairly well defined in the best of current practice both in private and in public schools.

Vocational Education. — In the field of vocational education, it is only within the last few years that there have been organized schools designed to reach the rank and file of our workers and to train for the non-professional occupations. For many centuries, a few select schools have existed for those entering the so-called "professions." It is now apparent that apprenticeship and the other means of so-called "shop training" for vocation have diminished greatly in their efficacy as agencies of vocational training. Intelligent workers in all phases of social economy now realize that it is indispensable for society to undertake, in a systematic way in schools, the vocational education of those to whom skill and technical knowledge will be necessary assets in their future callings.

The specific objectives, or utilities, to be realized through vocational education must, of course, be as numerous and varied as are the specialized occupations which men and women enter under present conditions. It is now generally recognized that there can be no such thing as general vocational education. The only true vocational education is that which bases its aims and practices upon the recognized needs of some definite calling, or group of very closely related callings. To this end, we can classify occupations, although not completely, under such general heads as: the professions; the agricultural callings; the commercial callings; the industrial callings; the household arts callings; and the nautical callings. Within each of these fields it is possible to differentiate many occupations for which specific training in schools may now be given.

Expert opinion is inclining strongly to the view that successful vocational education will require as a condition of its efficiency in most fields, and more particularly in those followed by the rank and file of workers, a large degree of concentration in the actual practice of the activities characteristic of the calling towards proficiency in which pupils are being trained. The so-called related technical education and whatever other training may be designed to give vocational insight must be effected largely upon foundations of habits, knowledge, and ideals already established through actual practice of the more vital phases of the occupation itself. It is for this reason that so many educators are now turning towards employers and others in charge of industrial activities with a view to procuring their coöperation in devising programs of satisfactory vocational training. If such coöperation cannot be achieved in any particular calling, it will be incumbent upon the school itself to develop the proper shops, farms, commercial activities, or other means of providing a basis of practical experience as a means of giving an effective education.

Social Education.—Under the general head of social education are here included all those special forms of training in habits, appreciations, sentiments, knowledge, and ideals which have an important bearing on social or group life. It is recognized, of course, that physical education and cultural education make important, but nevertheless incidental, contributions of by-products to social education as here defined. It is clearly possible and desirable to make social education an end or aim in itself, within due limits, especially in secondary schools. But to define a profitable field of activity for the school, careful attention must be given to the vast possibilities, and to the actual accomplishments, of the home, the church, the club, and miscellaneous associations, in shaping social habits and ideals, and in developing social intelligence.

After due recognition shall have been given to the efficacy of the more or less organized efforts of these non-school

agencies, the function of the secondary school in social education then remains to be defined. Emphasis has often been laid, and rightly, upon the fact that the secondary school, dealing, as it does, with adolescents, possesses a peculiar field of opportunity in the shaping of the finer social ideals, such as those connected with general service to society, altruism, and political insight.

The making of an effective program of social education will require the formulation of a large variety of ends, each representing some form of social utility, towards the attainment of which secondary school practices may be directed. It is here practicable only to give samples of these.

1. Team play, whether in physical, vocational, or cultural matters, offers an opportunity for the development of certain habits of coöperation which, once established, may be expected to blend into the larger social effectiveness of the adult.

2. Knowledge of the common civic activities carried on in the community, with provision that in the process of learning these the student may observe and even participate where practicable, constitutes a valuable end of local civic education.

3. Habituation to a sound moral working order, including a measure of self-government, may be an important factor in social training.

4. It is possible to inspire ideals of social service, — these, as far as practicable, being developed in connection with the pursuit of attainable and practical ends, such as those found in local community civic activities, local forms of charity, etc.

5. It is also possible, in the secondary school, to develop perspective and vision as to special forms of social activities, such as the economic development of the community, recreational opportunities, coöperative sanitation, coöperative industrial development, territorial differentiation of industry, and the like. As a means of promoting this vision or perspective, history will contribute valuable elements. It is

essential, however, that the pursuit of these ends should always be begun in the environment, and that only after this beginning should there be a spreading outward.

6. It is also possible to do much at this stage in creating moral and social ideals in definitely differentiated fields, such as the humane treatment of animals, reverence for the helpless or the aged, thoroughness of work, and the like. For this purpose art, literature, and history may contribute important elements, no less than the close study of the social environment of the pupil.

In these and scores of other directions it will be possible to set up more or less definitive goals, each of which may be attained at an appropriate time and through the use of appropriate materials and personal agencies. Educational efforts in these directions are all designed to promote the development of those habits, sentiments, appreciations, ideas, and ideals that finally blend themselves into what we call "moral character," "ethical standards of conduct," "the social individual," etc.

Cultural Education. — Finally, we can recognize in the completed individual, and as the actual or potential product of educational agencies like the school, a variety of forms of culture which ultimately merge in the rounded, cultivated man or woman. These may be described, on the one hand, as powers of execution or expression. For example, we describe an individual as capable of speaking correct English, conversing fluently in a foreign tongue, reading the literature of a foreign language, as being able to paint, to play music, or to write poetry. But on the other hand the larger part of such cultural attainments are properly to be described mainly in terms of appreciation, — the capacity for making wise and social choices for utilization or enjoyment. With reference to such fields as music, art, literature, science, history, economic production of all sorts, and skilled service generally, we can recognize in the cultivated individual well-de-

veloped powers of choice. The qualities found in all of these specific products and forms of service are themselves determined ultimately by the educated powers of consumers. A conscious and deliberate plan of liberal education can produce better capacities of appreciation than are now found. Such powers of appreciation will be discovered to be consistent with the more rapid progress of culture and civilization.

How far the existing secondary school subjects can be adjusted to the requirements of cultural education as here defined is now problematical. In the case of many of them it may indeed be doubted whether any extensive development in this direction is possible. We have, for example, no sufficient evidence that a profound, varied, and lasting appreciation of literature generally results from a study of literature as now carried on in high schools. Science teaching as at present organized is open to criticism on the ground that, whatever else it produces, it does not result in enduring satisfactions based upon the attainment of scientific knowledge, nor in the abiding scientific interests which constitute the cultural ends that should be reached in a true educational process. It is also obvious that secondary school education to-day fails to realize ends of true culture in such fields as the fine arts and music.

In defining a variety of fairly concrete cultural ends, each one of which may be made a definite educational objective, we certainly should greatly increase the possibilities of the secondary school as an agency of genuine liberal education. This would give opportunity for the more satisfactory consideration and use of native interests and inclinations than is possible under existing conditions in secondary education. Culture, it is clear, being an individual possession, may well vary greatly in character and actual content as between individual and individual. One person may have highly developed powers of appreciation of music and other forms of art, and nevertheless remain relatively uncultivated in such

fields as science and history. Another individual will find his satisfactions and the enrichment of his leisure in the latter fields. A third may have his powers of appreciation developed in the direction of the more material economic products of modern life, and may by his standards of appreciation contribute his share to the general elevation of these fields of production.

It is to be expected that in certain departments of common or general utilization, the secondary school will do all that it can to promote standards for all alike. For example, we all utilize, in greater or less degree, the products of the modern press, such as the newspaper, the magazine, and current books. The secondary school can do a large service for culture, by deliberately improving standards of taste within these fields, employing for this educational purpose the actual products themselves, and holding definite standards of desirable quality before the pupils.

Culture Primarily Based on Contemporary Life. — It should be obvious that a program of cultural education of the sort here suggested, like the other programs referred to above, must generally have its foundations and primary sources in contemporary life. Only upon the foundations of a strong and varied knowledge and appreciation of contemporary situations and tendencies, with a deliberate forecasting of the possible developments of these in the future, will the teacher and pupil be able finally to reach back into the historic world. It is reasonable to expect that with suitable pedagogical programs devised for this purpose, there will be a constant tendency for exceptional minds to become keenly interested in the historical antecedents of the particular fields which are being studied at any one time. It is natural and desirable that all that material which we call the historical, as well as that which deals with the more recondite and more remote phases of any subject under consideration, should appeal to individuals of exceptional native powers. But it

is not wise or profitable to impose upon all individuals alike the tasks and goals of learning that really appeal to exceptional individuals only.

Personal Culture and Achievement.— Under the head of personal culture as indicated above are to be included those powers of accomplishment or achievement, or “doing,” which are of a cultural, rather than of a vocational, nature. Under this head may be included the mastery of a foreign language as a tool of appreciation. Similarly, a mastery of certain of the technical processes of science, mathematics, history, or art, when such mastery is sought primarily with a view to enhancing the powers of appreciation or execution in these fields, would be considered cultural education. A student might give effort to the mastery of gardening or of music or drawing, for cultural purposes, that is, non-vocational appreciation, which would belong properly in this field.

Obviously, prior to the period of the beginning of secondary education, the study of the mother tongue, of arithmetic, and of elemental processes in drawing, as these constitute a part of the program of elementary education, might also be included under this head.

REORGANIZATION OF SECONDARY EDUCATION NECESSITATED BY FOREGOING ANALYSIS.— The foregoing attempt to suggest beginnings in defining valid educational aims, if carried to the point of producing definite results, would probably involve some fundamental alterations in the educational means and methods now employed. Some of the present traditional studies of the secondary schools, representing, as they do, organized bodies of knowledge, or definite forms of skill to be acquired by painstaking effort, would sink into the background as to importance. In their place would appear wholly new subjects, with corresponding demands for new types of method, varied according to the ends held in view and according to the degree of attainment expected in any given direction. Only a few illustrations of these possible

changes can be suggested here. It should be apparent that, having once defined in a clear-cut way the social utilities that are to be made the ends of educational effort, the development of appropriate means and methods of attaining them would not be difficult. This would be accomplished partly through proper application of experiments in educational method. Justifying this approach, we have the analogies of medicine, engineering, agriculture, and mechanical communication. In these fields it is evident that whenever the ends of attainment have been somewhat clearly defined, many persons are found capable of attacking the problems of the means and methods of realizing such ends.

In Physical Education. — When, for example, a particular form of physical development or health becomes defined as something to be attained by educational means, many devices for meeting it soon appear. If the development or cultivation of bodily organs is made an end, gymnastic practices result. If it is found that the promotion of natural exercises and advanced forms of play can best be accomplished by team activity, team games and athletics are the outcome. If the school perceives that it is its duty to fix in the pupil habits of oral hygiene, definitive processes of information-giving and inspection of actual practice may follow in such a way that within a comparatively short time appropriate habits are fixed. If the school finds justification for giving definite instruction as to hygienic precautions to be taken against bacterial infection of various sorts, such instruction becomes easily possible by means of lectures, printed matter, pictures, practices of disinfection, etc.

The significant fact to be noticed is that we multiply means and methods in any direction as soon as definite needs and purposes are defined. Practices are adapted to the results sought; for one purpose, perhaps, we employ a lecturer; for another, a field exercise. In one case we may employ the method of class compulsion; in others, the method of individ-

ual interview and personal contact. For some purposes of instruction, a thousand pupils may be assembled and addressed by a competent leader; while in other cases individual conference only will achieve the results desired. Books and laboratory practice may be used for some purposes, while for others only directed practices in the field will be valuable.

In Vocational Education. — Similarly, in the field of vocational education, when we have once defined our objectives, we find ourselves rapidly moving towards definite forms of practice, which will differ widely from the historic school practices of academic education because of difference of fundamental aim. The modern vocational school presents endless characteristics differentiating it from secondary "schools" as we have known them. The greatest difficulty encountered in the development of vocational education is, indeed, due to the attempt to utilize the means and methods of academic instruction as these have become fixed in custom. But gradually, as definite objectives for vocational education become formulated, we are now discarding historic practices, and for each particular type of vocational education we are developing appropriate ways and means, of which the most dominant characteristic, perhaps, is that the learner shall actually participate in the elementary stages of the practice of the calling into which he purposes to enter.

In a good school for the training of machinists to-day, shop conditions are faithfully reproduced; technical instruction is closely related to practical experience; the shop seeks to produce a marketable product; the school day and school year approximate those of the industry itself; and, to some extent, pupils differentiate into those exercising specialized operative functions and those exercising foremanship functions in the industry.

Modern farm schools, at their best, require of their pupils long and painstaking application to the processes of actual tillage, each pupil endeavoring to reproduce, as far as prac-

ticable, the economic cycle of operations appropriate to agriculture.

Similarly, wherever practicable, vocational schools seek to share with actual economic agencies the responsibility for the full vocational education of the pupil. Undoubtedly, in time a system will be devised whereby the pupil will remain under the general direction of the school during the earlier stages of learning, his services being loaned or hired out from time to time to the industry itself, as this proves expedient or necessary, in the process of vocational training.

In Social Education. — Within the field of social education it is also easily apparent that means and methods of instruction must vary largely according to the specific social utilities held in view. For example, it is a large function of such education to produce moral or social ideals. Ideals are to be produced by educational influences that are far removed, in their essential characteristics, from the drill methods characteristic of historic academic education. With reference to many forms of social action, the school seeks to give comprehension, perspective, insight; but it does so, as far as possible, upon the basis of actual experience. The attainment of this experience, of course, will be largely along lines that are at present quite foreign to secondary school practice. Such experience may be obtained in various forms of service, in activities such as those found in the Boy Scout movement, in young people's clubs, and in various other forms of modern social life.

The school social group will more and more become a self-governing body; in other words, more self-consciously social and self-controlled. Books, lectures, library practice, and participation in social activities will all have a place in social education at its best; but it is obvious that at the present time we possess few formulas for this purpose.

In Cultural Education. — The accepted methods of secondary school instruction seem best adapted perhaps to the

production of what is here called "personal culture." Nevertheless, the changes that must take place even in this field, before the specific ends suggested above can be effectively utilized, may be described as almost revolutionary. These will be especially conspicuous in the production of those forms of culture which are characterized chiefly by appreciation and the power of choice, rather than by specific powers of intellectual execution. We know little as yet about the psychological principles involved in producing fine appreciation; but what we do know convinces us that it must come, in a large measure, as a result of social activity built on tastes and interests already in evidence and capable of extended definition and development. If specific ends of culture are set before educators, it may not be so difficult to devise methods of realizing such ends. For example, suppose we define, as one aim of cultural education, the development of a discriminating appreciation of good music. The definition of this as an end carries with it suggestions as to how such results can be achieved. Let us again define, as an aim, the development of a generous and sympathetic appreciation of the contributions of the modern doctrine of evolution to contemporary thought. Here, again, the suggestion of the end carries with it ideas of lectures, of skillfully directed reading, and the like, the outcome of which would be the same as that produced in a good college or extension course of lectures for this purpose.

Let us again define, as an aim of secondary education in this field, a discriminating and helpful attitude toward modern magazine literature. Many examples of this literature would obviously be brought into a class organized for this purpose. A discriminating pedagogy would learn how, by questioning, by appealing to native and already established tastes, gradually to raise the student's standards in this field.

In these and hundreds of other directions it seems to be possible, having once defined valid educational aims, to devise methods by which these aims can be realized.

Effect on the Traditional Subjects. — It has been assumed that it is not within the province of the present chapter to discuss the reorganization of secondary education as that will be affected by changes now taking place, or probably soon to take place, within the field of the content and method of the historic subjects of study in secondary schools. The preceding chapters, together with the large amount of educational literature now available in this field and to which references have already been given, render such discussion unnecessary.

It is the conviction of the writer that changes and readjustments made within the historic subjects can be effective and of permanent value only when the teachers of these subjects already possess quite clearly defined objectives which conform to the requirements of a scientific program of education. We may, for example, readily assume that in the field of so-called English composition the aims now commonly accepted are sufficiently definite, scientific, and based upon a sound scheme of social values, so that readjustments within that field, both as to scope and as to method, will finally result in making the subject what it should be educationally. It is possible, also, that in the case of the modern languages it will be practicable to shape definite programs, both of content and of method, on the basis of aims already in part defined. In other words, it may be that the scientific aims which should ultimately control in the teaching of French and German, for example, are even now sufficiently possible of definition to make readjustments of content and method purposeful and effective.

In a few other departments of secondary education, such as the biological sciences and the practical arts (manual training, agriculture, home economics, etc.), it is possible that aims are now in process of being clarified to an extent which will enable more scientific and effective programs, based upon genuine social utilities, to be developed within the next few years.

In other subjects, however, such as mathematics, history,

the classical languages, and such sciences as physics and chemistry, it is the conviction of the writer that no readjustments within the field of either content or method will give satisfactory results until such time as valid aims for these subjects shall have been defined, examined, and carefully tested. An illustration of this may be found in the case of Latin. There can be little doubt that during the last quarter of a century the methods of teaching this subject have enormously improved, but notwithstanding this fact the subject itself does not to-day "function" educationally to any better advantage than in former times. The difficulty now lies not so much in the methods of teaching Latin as in the more fundamental problem as to the purposes of this study in a scientific scheme of secondary education.

Administrative Changes Necessitated. — In this chapter, also, there has been a deliberate omission of any discussion of administrative changes that must necessarily accompany the reorganization of secondary education. An adequate treatment of possible administrative changes can be based only upon accepted theories as to the ultimate purposes, means, and methods of secondary education. Such possible changes have already been suggested in Chapter V.

It is still uncertain, for example, whether vocational education can be effectively carried on through and by the same administrative agencies that control liberal, or general, education. The experience of several European countries has been decidedly in the direction of providing separate administrative agencies for vocational education. The question is still under debate in American states, with the present tendency strongly in the direction of differentiating vocational education as simply one phase of all the education under public educational authorities. It is by no means certain, however, whether this will prove to be the most effective means, once clearly defined aims for vocational education are established and accepted.

It is clear, also, that in the field of more adequate training for citizenship, and perhaps in physical education, the requirements of the future will necessitate extensive changes in the internal administration of schools. This, however, is a subject which is too problematical to be capable of adequate discussion at the present time.

THE FINAL WORD IS THIS.—In America, as in other civilized countries, society is in process of developing a sound and scientific social economy. This economy will necessarily be based upon a more or less scientific scheme of social values, thoroughly analyzed. It will be the province of education to minister to a realization of these values by training boys and girls in directions quite definite and demonstrably worth while. The content, the method, and the administrative agencies suitable to such education must be worked out as instrumentalities, and must be shaped and changed according to the requirements of the particular aims held in view. Until educators learn to think of the final purposes of education in terms other than mastery of so much knowledge or training in particular forms of skill, progress will necessarily be slow. When, however, educators cease to think of educational ends in terms of subjects and proceed to define their aims in terms of an ascertained scheme of values based upon a scientific social economy, then rapid reorganization of means and methods will undoubtedly take place.

NOTE.—The list of topical questions and the bibliography appended to each of the preceding chapters of this volume all relate more or less directly to the subject matter of this concluding chapter.

INDEX

- Abilities of students, as determining secondary education, 10, 13.
- Academy, 44; catered to students' interests, 11.
- American: origin and development, 54-57; developed into high school, 63; difference from high school, 67; decline of, 66.
- English: characteristics of, 46-47. *See also* Realschule.
- Acceleration and retardation, 248-249.
- Accrediting of high schools, 161, 163-172; Eastern system, 170-172; Western system, 163-169. *See also* Administration; College Entrance Examination Board Examinations.
- Addams, Jane C., quoted on narrow influence of high school teachers, 350; on recreation, 334.
- Administration, in England, 132-134, 135; in France, 74-101 (outlined, pp. xii, xiii); in Germany, 102-105, 115-117.
- In United States: changes now in progress, 747; changes necessitated by formulation of new aims and methods, 773; high school systems, 64-68, 146-172 (outlined, p. xv); organization of high school, 174-214 (outlined, pp. xiv-xvi); socialization of, 736-737. *See also* Accrediting of high schools; Age of beginning secondary education; Budget, school; Education Act of 1899; Endowed Schools Act; Examinations; High Schools; Hygiene, School; Inspection of high schools; Number of schools; Principal of high school; Reorganization of secondary education; Salaries; School population; Teachers, preparation of; Text-books; Tuition; Types of schools.
- Adolescence, biological definition, 246; importance in education first emphasized by Rousseau, 9; intellectual growth during, 297-298; mental pathology of, 292-298; method of studying, 257, note; physical characteristics, 248-257; psychological phenomena of, 257-272, 321; psychology and hygiene of, 234, 312; religious and moral aspects, 285-292; 275, note; social aspects, 272-285.
- Advisor system in high schools, 194.
- Aesthetic side of vernacular teaching, 369.
- Age, of beginning secondary education in America and in Europe, 9; as determining ideals, 289-290; physiological, psychological, and "pedagogical," 248; physiological, in relation to success in high school, 249; physiological and psychological, delimiting secondary education, 9, 10, 13.
- Agencies contributing to education, 756-758.
- Agrégation*, 89, 100.
- Agricultural education, history of development, 671-673; present problem, 678-679; types of schools, 673-678. *See also* Vocational education.
- Agricultural high schools, seldom realize vocational ends, 749, 750.
- Agriculture, as an element of cultural education, 767; position in the curriculum, 476. *See also* Agricultural education.
- Aim, relation to content and method, 203; of the academies, 55; of commercial education, 663; of Greek schools, 17, 23; of industrial education, 642; of realistic education, 45; of the Renaissance-Reformation schools, 38; of secondary education as it is, 748, 749; of secondary education as it is often claimed to be, 749; of the various subjects: algebra, 532; art, 582; athletics, 709; biology, 752, 753; civics, 573; geometry, 537; Greek, 406-407; household arts, 610; hygiene, 685; Latin, 388; literature, 358; manual training, 658; mathematics, 530; modern language study, 424; music, 603; physical education, 699; natural sciences, 446-449.

- Aims, clearer definition now being sought, 747; formulated, suggest methods of attainment, 768, 768-769; inadequate character of present, 745; inadequate, the cause of much futility in education, 750; more scientific analysis of, demanded, 746.
- Algebra, 530; definition, 531-532; in grammar grades, 541-544; in secondary schools, 534-536; in European schools, 536; reasons for studying, 532-534. *See also* Geometry; Mathematics.
- Allgemeine Landrecht*, 123.
- Altruism, in adolescence, 275.
- Angell, as to transfer of training, 304.
- Approbation, love of, in adolescence, 274-275.
- Argument, as a form of composition, 374.
- Aristotle, quoted on the distinction between elementary and secondary education, 20.
- Arnold of Rugby, 125; and the classics, 344; and religion in education, 349; and sources of energy, 319, 323, 347.
- Arrested development during adolescence, 292-294.
- Art, adolescent interest in, 308; as an element of cultural education, 767; gallery, use of school as, 740; importance in education, 578, 580; methods of teaching, 582-587; in education, principles underlying, 579-582.
- Arteries, growth during adolescence, 254.
- Arts, classification of, 578; design as relating fine to practical arts, 578-594; distinction between fine and useful, 579; university work in, originally given in secondary schools, 72. *See also* Art; Fine Arts; Household Arts; Music; Vocational education.
- Ascham, 43; a tutor, 46; and the classics, 344.
- Association, of Colleges and Preparatory Schools of Middle States and Maryland, 383; of Southern Colleges and Preparatory Schools, 383.
- Astronomy, in high schools, 475.
- Athletics, in American schools, 720-729; contestants *vs.* spectators, 711-716; control of, 720-724, 725-727; definition, 713; educational values, 709-716, 727-729, 736; in English public schools, 128-129; evils of, 716-720; socialized, 739. *See also* Hygiene; Physical education.
- Auchmuty, Richard T., founder of New York Trade School, 649.
- Bacon, mentioned, 50.
- Bagley, W. C., on investigation of adolescent criminal tendencies, 296; as to transfer of training, 304.
- Bagster-Collins, E. W., contributor, p. ix, *Modern Languages*, 424-443.
- Baker, F. T., contributor, p. viii, *Composition*, 373-379; *College Entrance Requirements*, 383-384; and Krapp, G. B., p. vi, *English Literature*, 356-373.
- Baron de Hirsch Trade School, 649, 650.
- Basedow, 51.
- Bedford Grammar School, 131.
- Bell, monitorial scheme in America, 61-62.
- Bell, Sanford, on adolescent love, 264-266.
- Biographical interest in literature, 366-367.
- Biology, actual *vs.* true aims, 752, 753; aims now being clarified, 772; in the curriculum, 476; advantages, 486-488; correlation of botany, zoology, and physiology, 494-495; method, 488-494; subject matter, 486. *See also* Natural sciences.
- Bôcher, Professor, definition of mathematics, 529.
- Bones, growth during adolescence, 253; hygiene, 253.
- Botany, *see* Biology.
- Bourne, H. E., contributor, p. ix, *History*, 549-565.
- Boy Scout movement, 272, 760, 770.
- Bradford Grammar School, 131.
- Brain, growth during adolescence, 257.
- Brinsley, on neglect of arithmetic, 40, 43.
- Brooks, on causes of school mortality, 271.
- Budget, English school, 136; French, 93-94, 100. *See also* Administration.
- Canning Club work, 634.
- Censor of studies, a discipline master, 88.
- Centennial Exhibition, and manual training, 661.
- Central High School of Philadelphia and commercial education, 667.
- "Central Schools" of France, 73.
- "Certificate of secondary studies," in girls' *lycée*, 99.
- Certification of high schools, *see* Accrediting.

- Character building, as aim of education, 749.
- Charter-house, 124.
- Chemistry, actual *vs.* true aims, 752, 753; in the curriculum, 475, 476; beginning point, 509-512; method, 508-509, 513-515, 516; practical applications, 517-519; subject matter, 513, 515-516; textbooks, how to use, 512-513. *See also* Natural sciences.
- Church, its assumption of school control, 30-31; a factor in education, 757, 758, 760, 762.
- Cicero, quoted, on oratory, 26.
- Circulation, disturbances during adolescence, 255.
- Citizenship, good, as an end of education, 746.
- Civics, definition, 565; introduction into schools, 565-567; methods of teaching, 569-572; position in curriculum 567-569, 572; purpose in teaching, 573; socialized methods, 736, 741; textbooks, 570, 573. *See also* Economics; History.
- Civil polity, as a part of civics, 565.
- Class conference *vs.* recitation, 460.
- Class distinction, conferred by secondary education, 6, 7.
- Classics, in English "public" schools, 125.
- Claxton, Commissioner, suggestions for greater efficiency of high schools, 201.
- Clergy, the sole profession in Middle Ages, 5, 30.
- Club, a factor in education, 757, 758, 762.
- Coeducation, in relation to adolescent development, 308-310; nonexistent in Germany, 115.
- Collège, de Guyenne, curriculum, 42; d'Harcourt, oldest secondary school, 72; de la Rive, curriculum, 41-42.
- College, developed from academy, 57; dominance of, 748; French communal, 75, 95; relation to high school, 188; Entrance Certificate Board, of New England, 170-172; Entrance Examination Board, 163, 383, 384, 433-434, 473, 544; effects on high school science teaching, 474-475; entrance requirements, early, 58; in English, 382-384; in mathematics, 544-546; in history, early, 553; in modern languages, 433; in natural sciences, 473-475.
- Colvin, S. S., quoted on transfer of training, 303-304.
- Comenius, 51.
- Commerce, High School of, New York City, 667; course of study, 668-670.
- Commercial education, in public high schools, 664-670; origin and need of, 663-664; results, 670; socialized methods, 735-736; teachers, 671. *See also* Types of schools; Vocational education.
- Commercial high schools, seldom realize vocational ends, 749, 750.
- Commission of Accredited Schools, purposes, 167; recommendations, 168; Southern, 169.
- Committee, on college entrance requirements, 473-474; recommendations in science, 476; of Fifteen, civics, 566; of Five, civics, 568, 571; of Seven: civics, 566, 571, history, 557; of Ten: appointed, 76; economics, 573; English, 383; history, 554-555; same education for all students, 194; science teaching, 473; of Twelve, 433, 445.
- Composition, aim in language, painting, sculpture, 373; aims (in language) already well defined, 772; definition, 373; distinguished from rhetoric, 373; four fundamental forms, 373-374; teaching of, 374-379. *See also* Literature; Vernacular.
- Concordat, abrogation of, 73.
- Conduct, ethical standards of, as result of education, 764.
- Content of subject, to be determined by purpose in teaching it, 203-204; from social viewpoint, 734.
- Control of schools during the Renaissance-Reformation period, 38, 39.
- Cooper Union, of New York City, 647.
- Coöperation between school and home, 335; between school and industries, 627, 652-654, 762, 770.
- Coover, as to transfer of training, 304.
- Corderius, method, 43.
- Correspondence schools, 654.
- Crampton, on relation of physiological age to success in high school, 249.
- Criminality during adolescence, 294-297.
- Crosswell, James G., contributor, p. viii, The Private Secondary School, 233-243.
- Cubberley, E. P., contributor, p. vii, State Systems of High Schools, 146-149; Maintenance and Support, 154-161.

- Cultural education, analysis of aims, 765-767; definition, 759, 764-766; reorganization based on new aims, 770-771.
- Culture, as the aim of education, 746, 749.
- Curriculum, the academies, 57-60; E. Armston's school for girls, 59; place of design in: Europe, 593-594, United States, 593; English public schools, 33, 34; failure to prepare for parenthood, 337-338; of French secondary schools, 78-80, 96; German secondary schools, 49-50, 108, 109, 110-111, 113.
- High school: changes and characteristics, 214-216; early development, 67-68; factors in determining, 177; rural, 150-151; similar in all high schools, 147-148; socialized, 734.
- Latin grammar schools, Renaissance-Reformation period, 40; in America, 53; Roman grammar school, 27; service of the academy to, 45; social viewpoint, 734-735; vocational idea, 333. *See also* Elective system; Program of studies; and Biology; Chemistry, etc.
- Cygnæus, Otto, pioneer in manual training, 660.
- Dante, quoted, on exposition, 35.
- Davis, as to transfer of training, 304.
- Declamation, the teaching of, 379.
- Degrees, French, *agrégation*, 89; baccalaureate, 85-87; substitutes for, in the case of girls, 99.
- Delsarte system of exercises, 700.
- Dementia præcox*, 292.
- Democratic function of secondary school, 9, 13. *See also* Universal education.
- Denominational schools, 241.
- Description, as a form of composition, 373-374.
- Design, place in education, 592-594; in fine arts, 589-592; the link between fine and useful arts, 587-588; in practical arts, 588-589, 590-591. *See also* Art; Arts; Fine arts; Industrial education; Manual training.
- Development, arrested during adolescence, 292-294.
- Dewey, John, contributor, p. ix, Art in Education, 578-582; quoted on conduct, 315; on cultivation of will, 329, note; on means of gaining power, 313-314; on media of training in school, 338; on the teaching of history, 205-206; and the University Elementary School of Chicago, 660.
- Direct method of language teaching, *see* Oral method.
- Discipline, dependent on understanding of adolescence, 188; relation to public sentiment of school, 189. *See also* Formal discipline; Self-government.
- Diversification, of secondary schools, in Europe, 14; needed in America, 15; of educational opportunities, 745.
- Dogmas, educational, now giving way, 746.
- Double periods, 180.
- Dow, A. W., contributor, p. ix, *Methods of Teaching Art*; Design, 582-594.
- Drexel Institute, Philadelphia, 655.
- Dulwich, day school, 131.
- East India School, 51.
- Ebert, as to transfer of training, 303, 304.
- École Polytechnique*, 439.
- Écoles pratiques*, 673-674.
- Économique*, bursar, 88.
- Economics, definition, 573; introduction into the schools, 573, 574; methods, 574; textbooks, 574. *See also* History; Civics.
- Eddy, W. H., on teaching of sex hygiene, 270.
- Edelschulen*, 44.
- Education, causes of present multiplied demands upon, 745; its agencies in developing the individual, 757. *See also* Agricultural education; Commercial education; Elementary education; Industrial education; Moral education; Physical education; Primary school; Religious education; Secondary education; Social education; Vocational education.
- Education Act of 1899, England, 132-134. *See also* Administration.
- Efficiency, attained only by arousing will, 315; demanded by society, 734-735; of German secondary school system, reason for, 105; of high school determined by its administration, 174-175; how to attain, in American industries, 647; impossible without valid aims in education, 750; secondary education must be a training in, 14, 15.
- Eighteenth-century conception of secondary education, 6, 7.
- Elective system in high schools, 220-226;

- French, German, and American systems compared, 114-115. *See also* Curriculum; Program of studies.
- Elementary education, distinction from secondary education:
- First made by Greeks, 16; origin of the practical distinction, 16-19; origin of the theoretical distinction, 19-21.
 - Factors in the distinction: badge of class distinction, 6, 7, 12, 13, 71-72, 77, 105-106, 130; deference to student's interests and abilities, 10, 11, 13; method, 3, 4, 12; peculiar subject matter, 4, 12; preparation for profession, 5, 12; preparation for professional training, 6; physiological and psychological age, 9, 10, 13, 246, 249-250, 208; social selection, 7-9, 13, 123-124; training, not instruction, 3, 12.
 - At present: a complex of these factors, 11-14; in addition, social service and personal efficiency, 14, 15. *See also* Primary school; Secondary education.
- Elementary school, superseding secondary school in fundamental importance, 2.
- "Elementary science" courses, 475.
- Elocution, as a separate branch of English training, 381-382.
- Endowed Schools Act, England, 125. *See also* Administration.
- Endowments in Middle Ages, 31-33.
- Energy, sources of mental, 318.
- England, the academies, 46-47, 49-50; Greek in, 417-418; history in, 559-560; modern languages in, 442-443; school population, 140-141; secondary education in, 71, 122-141 (outlined, p. xiii, xiv).
- Englewood High School, coeducation but not coinstruction, 309.
- English, ability to use, as aim of education, 749.
- English Classical School, the first American high school, 61.
- Erasmus, quoted, 43-44, 344.
- Ethical ideals of adolescence, 291.
- Ethics, as part of civics, 565.
- Eton, 124; program of studies, 127-128.
- Examinations, French, 86, 99; German, 116; Regents', 202; teachers', in Germany, 104. *See also* Accrediting of schools; Administration; College Entrance Examination Board; College entrance requirements; Inspection of schools.
- Excursions, school, 271-272; for science study, 467-470.
- Exposition, as a form of composition, 373-374.
- Fall River, Mass., state-aided textile school, 655.
- Farnsworth, C. H., contributor, p. ix, Music Teaching in the Schools, 595-604.
- Farrington, Frederic E., contributor, p. vii, European Systems of Secondary Schools, 71-140.
- Fees, school, *see* Tuition fees.
- Fellenberg, 51; his scheme in America, 60.
- Fine arts, study of, failure to develop true culture, 765. *See also* Art; Arts; Household Arts; Music; Vocational education.
- Finland, manual training in, 660.
- Formal discipline, problem of, 298-306; and algebra, 534; experimental studies of transfer of training, 302-305; and geometry, 537-538; and Greek, 407; and Latin, 387-388; and manual training, 659; and modern languages, 424; and natural sciences, 446-447, 454-458.
- Foster, Dr. W. L., on physiological age in relation to success in high school, 249-250.
- France, agricultural education in, 673-674; history in, 558-559, 560; modern languages in, 439-442; school population, 140-141; secondary education in, 71, 72-101 (outlined, p. xii, xiii).
- Francke, 48.
- Franker, as to transfer of training, 304.
- Frankfort-plan schools, 113.
- Frankfort system, and teaching of Greek, 416.
- Franklin, Benjamin, 53, 54.
- Franklin Union, of Philadelphia, 647.
- Frauenschule*, 116, 117; weekly program, 119.
- Free schools, *see* Tuition fees.
- Freud, on sex manifestations, 259, 261, 263; therapeutic measures, 294.
- Froebel, 1; a tutor, 46, 51.
- Fürstenschulen*, 44, 47.
- "Gangs," 275-276.
- "General science" courses, 476.
- Geography in the curriculum, 475, 476; be-

- ginning point, 477-479; concepts to be given, 476-477, 482-483; method, 477-479, 483-485; order of topics, 485-486; textbooks and other sources of information, 479-481. *See also* Natural sciences.
- Geology, 475.
- Geometry, 530; definition, 536; position in grammar grades, 541-544; position in secondary schools, 538-539; reforms and improvements, 539-541. *See also* Algebra; Mathematics.
- George, W. R., his "Credo," 296-297; and sources of energy, 319.
- George Junior Republic, 323.
- German Association for the Secondary Education of Girls, 115.
- Germany, agricultural education in, 673-674; commercial education, 668; Greek, 406, 415-416; history, 538-559; industrial education, 645-649, 653, 655; Latin, 415-416; modern languages, 436-439; physical education, 704; school population, 140-141; secondary education, 71, 72, 101-122 (outlined, p. xiii).
- Ginnasio*, 36.
- Girls, first form of secondary education for, 7; first secondary schools for, in America, 59-60; education in England, 141; education in France, 94-101, 141; education in Germany, 115-120, 141; education in United States, 59-60, 648, 704-705. *See also* Coeducation; Household arts; Program of studies.
- Goodell, T. D., contributor, p. ix, Greek, 406-420.
- Grammar, origin, 4; mastery of, a profession, 5; change in content, 30.
- Grammar school, relation to high school, 186-188. *See also* Latin grammar school.
- Gréard, M., quoted on boys' and girls' secondary education, 94.
- Greek language, mastery for cultural ends, 767; method for beginners, 408-415; purpose and value, 406-408; place in schools, 125, 415-416; valid aims not yet formulated, 773; visual aids, 420-421.
- Greek view, of gymnastics and music, 580; of value of gymnastics, compared with present view, 328; of recreation, needed to-day, 334; of secondary education, 3, 16-21.
- Gregariousness in adolescence, 273.
- Griscom, John, and the high school, 61.
- Groton, Mass., school of horticulture and landscape gardening for women, 678.
- Group work in classroom, 284-285.
- "Growing pains," 253.
- Growth, arteries, 254; bones, 253; brain, 257; and health, 252; heart, 254; in height, 250; lungs, 255; muscles, 254; by parts, 252; in weight, 250.
- Guts Muth, system of gymnastics, 700.
- Gymnasium*, and agricultural education, 674; course of study, 108-109; Frankfurt system, 113; German form of the Latin grammar school, 30; graduates compared with those of *lycée* and England public school, 129; and Greek, 415-416; and history, 538-559; and mathematics, 536. *See also* Germany; not reached through elementary school, 107; one of the types replacing *Ritterakademien*, 47.
- Gymnastics, *see* Athletics; Greek view of gymnastics; Hygiene; Physical education.
- Habits to be developed by study of natural science, 449.
- Hall, Stanley, adolescent altruism, 275; appetite in adolescence, 201; on bone growth, 254; change of voice, 256; high school science, 300; leading investigator of adolescence, 257; note; love for older persons, 265; manifestations of sex instinct, 259; moral idealism, 347.
- Handwork, *see* Manual training.
- Harrow (1571), 124.
- Hartwell, on death rate in Boston, 252.
- Health in relation to adolescence, 252.
- Heart, growth during adolescence, 254.
- Hecker and *real* education, 28, 40.
- Height as an index of physiological age, 249; note; growth in, during adolescence, 250-252.
- Hellenism, value of acquaintance with, 406-408.
- Herbart, 1; a tutor, 46; on failure of external forces to change character, 313.
- Heredity, a factor in developing the individual, 757.
- Hero worship, and moral training, 344-345. *See also* Moral education.

- Hertel, on health during adolescence, 255.
- Hetherington, Clark W., contributor, p. x, Athletics, 709-729.
- High school, comparison with Latin grammar school and academy, 60-61, 67; definition (1849), 65; organization of, 174-229 (outlined, pp. xiv-xvi); origin of term, 61, 64, 65; origin and development, 61-63, 146, 235; social aspects of, 732-742 (outlined, p. xxvii).
Systems: development of, 64-68; highest types in the United States, 158-160; means of securing, 148.
- High schools, basis of apportionment of support to, 160-161; legal provisions for, 146; maintenance and support in various states, 154-158; method of transferring pupils to college, 161, by examination of applicant, 162-163, by accrediting the school, 162, 163-172; political unit of organization, 148-149; uniformity in, 146-148, 747-748. *See also* Administration.
- Higher Training School, German, 116, 117; weekly program, 120.
- Historic sense, development of, as aim of education, 749.
- Historical side of vernacular teaching, 367-368.
- History, aims: actual vs. true, 752, 753; valid, not yet formulated, 773; definition, 549-550; as an element of cultural education, 767; materials, 550-551; as means of moral training, 343, 344-345; methods: 564, Dewey quoted on, 205-206, socialized, 773; place in the curriculum, 552-555; place in European schools, 558-559; problems of teaching, 551-552; visual aids to teaching, 564-565. *See also* Civics; Economics.
- Home, a factor in education, 757, 758, 760, 762.
- Home life, as determining ideals, 290.
- Hoole, method in the Grammar schools, 43.
- Hopkins, Edward, and the Latin Grammar Schools, 52.
- Horace Mann period, 63.
- Household arts education, aims now being clarified, 772; close connection with life necessary, 611-612; clothing and hygiene, 612-613; content, 609-610; equipment, 618-619; exhibitions, 620-621; food and nutrition, 613-616; home formerly the place for teaching, 608; housing and home-keeping, 616-617, 610-620, 623-624; purpose, 610-611; socialized, 735; status in schools of United States, 632-637; teachers, 621-623; vocational aspect, 624-632. *See also* Types of schools; Vocational education.
- Humanism, long persistence, in England, 125-126; in France, 73.
- Humanizing the school, 193, 732-742. *See also* Social aspects of high school education; Social education; Sociology.
- Huxley, on the intellectual ladder in America, 106.
- Hygiene, of bone growth, 253-254; definition, 685; personal, 685-688; position in curriculum, 688-690, 692-694; scope of course, 690-691, 693-694; methods, 692.
- School, 694; of the school child, 695; of instruction, 696; construction and sanitation of schoolhouse, 696-698.
- Sex, instruction in, 266-270, 694; of voice during adolescence, 256-257. *See also* Administration; Athletics; Physical education.
- Ideals, adolescent, 330-331; developed by scientific study, 453-454; of sexual honor, 336-337; studies of, 289-292. *See also* Moral education; Reorganization of secondary education.
- Imperial Technical School of St. Petersburg, 661.
- Industrial education, definition, 642; European experience, 645-646; factors in present problem, 644-645; manual training, 658-662; origin of present problem of, 643; socialization of methods, 735; United States, conditions in, 646-658. *See also* Household arts; Industries; Types of schools; Vocational education.
- Industries, chart showing proportion of workers to boys in training, 196-199; coöperation with schools, 199-200, 737, 770. *See also* Industrial education.
- Inspection of high schools, 161, 164-169; not required for accrediting, 170-172. *See also* Accrediting of high schools; Administration.

- Institutions contributing to education, 757-758.
- Instruction, type of, as determining ideals, 290-291.
- Interests of students, as determining secondary education, 10, 13.
- Jahn, system of gymnastics, 700.
- James, E. J., and commercial high schools, 667.
- James, Wm., on formal discipline, 303, 304.
- Japan, agricultural education in, 673, 674.
- Jesuit system, selective function, 8; *Ratio studiorum*, a model for generations, 72.
- Johnson, Joseph H., contributor, p. x, *Commercial Education*, 663-671.
- Kerschensteiner, Dr., quoted on independent thinking, 315-316; on trade work in continuation schools, 645.
- Key, Axel, study of health in adolescence, 252, 255.
- Kline, on cause of truancy, 271.
- Knowledge, as well as feelings, indicated by tastes, 364-365.
- Krapp, George P., and Baker, F. T., contributors, p. viii, *English Literature*, 356-383.
- Laboratory, in biology, 493-494; in chemistry, 513, 517-518; double periods, 180; in geography, 484-485; in physics, 505-506; in science teaching, 462-467. *See also* Natural sciences.
- Lancaster, E. J., on adolescence, 260, 262; on types of reading preferred by adolescents, 308.
- Lancaster, Joseph, his monitorial ideas in America, 61-62.
- Land Grant Colleges, 672. *See also* Morrill Act.
- Language study, during adolescence, 307; socialized methods in, 735. *See also* Greek; Latin; Modern languages; Vernacular.
- Lantern slides, in study of Latin and Greek, 420; in natural sciences, 467.
- Latin, mastery for cultural ends, 767; methods of teaching, 389-405; place in the curriculum, 125, 387; reorganization needed, 751; valid aims not yet formulated, 773; value, 387-389; visual aids, 420-421.
- Latin grammar school, in American colonies, 37; narrow conception of abilities, 8; origin and development, 51-53. in Renaissance-Reformation period, 36-37; selective function, 8. *See also* *Lycée*; *Gymnasium*; "Public" schools.
- Leadership, training for, in ancient Greece, 20; in England, 123, 128-129; in France, 77, 101; in Germany, 106-107.
- Lecture demonstrations in science teaching, 467.
- Lehrplan* of 1901, on Greek, 406.
- Lewis, Dr. Dio, system of calisthenics, 703.
- Lewis, W. D., contributor, p. vii, *Organization of the High School*, 174-214.
- Lewis Institute, Chicago, 655.
- Library, a factor in education, 757, 758, 760.
- Life, influence of new conditions of, 234, 558, 608-610, 623, 644, 663, 672; relation of secondary education to, 732-742; in England, 123, 128; in Germany, 101; in United States, 194-201. *See also* Humanizing the curriculum; Reorganization of secondary education; Social aspects of high school education; Social education; Sociology; Vocational education.
- "Lime-hunger," 253.
- Lindsey, Ben., on sources of energy, 319.
- Ling system of gymnastics, 699, 700.
- Linguistic side of vernacular teaching, 365-366.
- Literature, adolescent interest in, 307; as an art, 582; failure of its study to develop appreciation, 765; as means of moral training, 343-344; Greek views of principles underlying its teaching, 356-357.
- English, in secondary schools, 357; appreciation, 358; cultural value, 362; grading of material, 363; literary language, 359-360; moral value, 362; philological method, 360; structure and technique, 361; vocabulary, 358-359. *See also* Composition.
- Locke, a tutor, 46; quoted, 50.
- Lodge, Gonzales, contributor, p. viii, 387-405.
- "Log college," preceding Princeton, 54.
- Logic, origin, 4; mastery of, a profession, 5; change in content, 30.

- Love, development of, in adolescence, 264-266.
- Lowell, Mass., State-aided textile school, 655.
- Ludus Literarius*, and the neglect of arithmetic, 40.
- Lungs, growth during adolescence, 255.
- Lycée*, a boarding school, 87-88; defined, 75; degree awarded, 85-87, 99; a finishing school — comparison of graduates with those of *gymnasium* or English public school, 129; French form of the Latin grammar school, 36; for girls, 94, 95; graduate courses, 80; history in, 558-559; modern languages in, 439-442; preparation of teachers, 100; program of studies, 80-85, 97-98; teachers and officers, 88; tuition fees, 93, 100. *See also* Collège; College, French communal; France, secondary education in.
- Lyte, Sir Maxwell, on education for public life, 124.
- Lyzeum*, 115, 116; weekly program, 118, 119. *See also* Germany; *Gymnasium*; *Oberlyzeum*; *Realgymnasium*; *Realschule*.
- MacKenzie, on voice training during adolescence, 257.
- Manchester Grammar School, 131.
- Manhattan Trade School, 624.
- Manual arts high schools, seldom realize technical ends, 749.
- Manual training, definition, 658; content of course, 660; educational value, 658-660; place in various national educational systems, 660-662; relation to industrial education, 662. *See also* Industrial education; Vocational education.
- Maps, in teaching the classics, 420.
- Massachusetts Commission on Industrial and Technical Education, 651.
- Mathematics, branches of the subject, 530; college entrance requirements, 544-546; as an element of cultural education, 767; nature and use, 529; reasons for studying, 530; reorganization needed, 751; scope of secondary, 531; valid aims not yet formulated, 773; visual aids to teaching, 546-547. *See also* Algebra; Geometry.
- Mechanics Institute of New York, 647.
- Melanchthon, 43.
- Mental training, as aim of education, 749.
- Merchant Taylors', 124.
- Meteorology, 475.
- Method, wider definition of, 747.
- In various schools: the academy, 60; service of the academy to, 45; development of: in high school, 67, 68; in Latin grammar schools of America, 53; in schools of Middle Ages, 34; in Renaissance-Reformation schools, 42-44; Roman contribution to, 27-29.
- In the various subjects: to be determined by purpose of teaching the subject, 203-204; art, 582-587, 592-593; biology, 488-494; chemistry, 508-509; composition, 375-379; English, 370-373; geography, 477-481, 483-486; Greek, 408-415; history, 560-564; Latin, 389-405; modern languages, 424-431, 437-439; music, 597-604; natural sciences, 459-472; physics, 496-498, 500-504, 505-508.
- Scientific, how to build up concept of, in mind of pupil, 456; value of the acquisition, 458-459; mastery of scientific method, as aim of education, 749.
- Methods, depend on aims, 754-755; more scientific analysis of, demanded, 746; new, have developed in secondary schools, 1; often uncertain and arbitrary, 745; reorganization needed, 753; socialized, 735-736.
- Meumann as to transfer of training, 303, 304.
- Meylan, G. R., and Storey, Thomas A., contributors, p. x, Hygiene and Physical Education, 685-705.
- Michigan plan of accrediting high schools, 164-167.
- Middle Ages, view of secondary education, 5; contribution to secondary education, 29, 30; use of Latin, 387.
- Migratory instinct in adolescence, 270-272.
- Military schools, private, 240.
- Milton, 46, 49; on value of classical study, 343-344.
- Milwaukee School of Trades, 649.
- Minister der geistlichen und Unterrichts-Angelegenheiten*, 102.
- Minister of education, French and German, difference in responsibility, 102-103.
- Minnesota agricultural college, 674.
- Models, of geometric solids, 546-547; use in teaching Latin and Greek, 421.
- Modern Language Association, 433.
- Modern languages, actual vs. true aims,

- 752, 753; alms already well defined, 772; mastery for cultural ends, 767; methods of teaching, 424-431, 437-439; place in curriculum, 431-443; purpose of study, 424; results of school work, 431; socialized methods, 737.
- Modistenschulen*, 44.
- Monitorial high schools, 61-62.
- Monroe, Paul, editor and contributor, p. vii, Meaning and Scope of Secondary Education, 1-15; Historic Sketch of Secondary Education, 16-70.
- Montaigne, quoted on method, 50.
- Moral aspects of adolescence, 285-292.
- Moral character, as result of education, 764.
- Moral education, 313-347, 350, 353 (outlined, p. xviii, xix). *See also* Religious education.
- Moral instruction, direct, 317, and note.
- Morrill Act, 648, 672.
- Mt. Hermon School, Mass., agricultural, 678.
- Municipal activities, course in, 567.
- Municipal civics, syllabus of, 567.
- Municipal government, courses in, 572.
- Muscles, growth during adolescence, 254.
- Music teaching in the schools, aim, 594-595; failure to develop true culture, 765; methods, 597-603, 736, 740; present broadening of use and appreciation, 595-597, 603-604. *See also* Art.
- Narration, as a form of composition, 373-374.
- National Conference on College Entrance Requirements in English, 383.
- National Council of teachers of English, 384.
- National education, *see* Universal education.
- National Farm School, Doylestown, Pa., 678.
- Natural sciences, aims, actual and ideal, 752; alleged inadequacies, 306-307; methods, 459-472, 735; mastery of scientific method as aim of education, 749; relation to college entrance requirements, 473-475; subjects taught, 475, 476; values, 446-459, 765, 767. *See also* Biology; Chemistry; Geography; Physics.
- Nautical callings, in vocational training, 761.
- New Bedford, state-aided textile school, 655.
- New England Association of Colleges and Preparatory Schools, 383, 554.
- New England Commission of Colleges, 383.
- New York Trade School, 649, 650.
- Newton High School, study of cost of various subjects per pupil-hour of recitation, 199.
- Non-conformity, effect on secondary education, 47, 54.
- Normal schools, developed from academies, 57.
- Normallehrplan des Gymnasiums*, and algebra, 536.
- Northampton School of Technology, 678.
- Number of schools, increase in Renaissance-Reformation period, 37-40; academies in America, 56; English "public," 124; English secondary, 136; German secondary, 111-112; high schools, 65-66; *lycées* and communal colleges, 87; rural high schools, 151-154. *See also* Administration.
- Nurture, a factor in developing the individual, 757.
- Oberlehrer*, 121.
- Oberlyzeum*, 116, 117; weekly program, 119, 120. *See also* *Lyzeum*.
- Oberrealschule*, 49, 110, 116; weekly program, 111. *See also* *Realgymnasium*; *Realschule*.
- Occupational ideals, variety of, 291.
- Ohio Mechanics Institute, of Cincinnati, 647, 655.
- Oral method of language teaching, 395-396, 410-411, 424-427.
- Orator, sole type of educated man in Rome, 28.
- Oratory, the teaching of ancient, 23, 26; modern, 379-381.
- Organization of high school, *see* Administration.
- O'Shea, M. V., quoted, on method, 203.
- Oster, Sir Wm., quoted, on value of Greek, 406.
- Palmer, Erastus, contributor, p. viii, Oral Speech, 379-382.
- Parents' meeting, 335-336.
- Particularschulen*, 44.
- "Passing," system encourages mental loafing, 329.
- Pathology, mental, of adolescence, 292-298.

- Paulsen, on voice control during adolescence, 256-257.
- Pedagogia, 44.
- "Pedagogical" age *vs.* physiological and psychological, 248.
- Peirce, Benj., definition of mathematics, 529.
- Perry, Clarence A., contributor, p. x, Social Aspects of High School Education, 732-742.
- Perse School, Cambridge, program of studies, 128; experimental work in teaching classics, 413.
- Pestalozzi, 51; his ideas in America, 60.
- Phelps, Jessie, on teaching of sex hygiene, 270.
- Philanthropinists, 51.
- Phillips' academies, 55.
- Physical education, adequate teaching will necessitate changes in administration, 774; analysis of aims, 760-761; definition, 759; early conceptions, 698-699; forms of gymnastic exercise, 700; gymnastics for girls, 704; gymnastics *vs.* athletics, 700-702; modern views, 699-700, 709; position in schools, 703-704; reorganization based on these aims, 768-769. *See also* Athletics; Hygiene.
- Physical efficiency as an end of education, 746.
- Physics, actual *vs.* true aims, 752, 753; beginning points, 495-503; in the curriculum, 475, 476; method, 496-498, 500-504, 505-508; subject matter, 495-496, 504-505; valid aims not yet formulated, 773. *See also* Natural sciences.
- Physiological age, concept of, 248; relation to success in high school, 249-250; *vs.* psychological and "pedagogical" age, 248.
- Physiology, *see* Biology.
- Physique, mental and moral advantages of developing the, 327.
- Plato, and the choice of studies, 343; on education for leadership, 20; on the teaching of literature, 356-357.
- Playground, a factor in education, 757, 758, 760.
- Police power, a factor in education, 757, 758.
- Political evils, one remedy may lie in high school extension, 742.
- Practical arts, aims now being clarified, 772. *See also* Household arts.
- Pratt Institute, Brooklyn, 655.
- Preparatory schools, private and public, 239-240; in England are not secondary schools, 130.
- Press, the, a factor in education, 757, 758, 760.
- Primary school, distinction from secondary, in France, 76-77, in Germany, 105-107. *See also* Elementary education.
- Principal of high school and board of education, 211-213; as critic of class work, 206; not to be a czar, 174; and the heads of departments, 206; and the narrow teacher, 201-202; open-mindedness necessary in adjusting school to life, 200-201, 738; and the principals of grammar schools, 186-187; relation to various activities of the school, 184; spirit reflected in school, 201, 738; visits to classes, 206. *See also* Administrations.
- Principalship, how to attract first-class men, 213-214.
- Private schools, definition, 233; advantages and disadvantages, 233-235; types of, 233-234, 237-241.
- Probejahr*, 121.
- Problem, defined, 446, note.
- Problems of youth, 320-321; discussed, 327-338; named, 325-326; points of contact between educator and educand, 325; sources of information concerning, 321-323.
- Professeurs*, teachers in a *lycée*, 88.
- Professions, secondary education a preparation for, 5; secondary education preliminary to preparation for, 6.
- Program of studies, Collège de Guyenne, Bordeaux (1572), 42; Collège de la Rive, Geneva (1559), 41-42; English grant school, 138-140; Eton, 127; *Frauenschule*, 119; French secondary schools, 80-85, 97-98; *Gymnasium*, 109.
- High school: academic including household arts, 630; of Commerce, New York City, 668-670; girls' technical, 627; typical examples of, 216-219.
- Lyzeum*, 118-119; *Oberrealschule*, 111; Perse School, Cambridge, England, 128; *Realgymnasium*, 110; Somerville, 628-629, 631-632; Sturm's at Strassburg (1565), 40-41; teachers' training school, Germany, 120; Worcester Girls' Industrial School, 625-626. *See also* Curriculum.

- Programs of studies, now flexible, 746.
 Progymnasium, 108, 111, 112.
 Promotion by subject, daily roster for, 177.
Provincial Schulkollegium, 103.
Proviseur, headmaster, 88.
 Psychological age vs. physiological and "pedagogical," 248.
 Psychological phenomena of adolescence, 257-272; pathological, 292-298.
 Psychology, effect of increasing knowledge of, on education, 745, 747. *See also* Adolescence.
 Puberty, vs. adolescence, 246; date of onset, 247-248.
 "Public" schools, English form of the Latin Grammar School, 37; and public life, 123-131; Winchester, the oldest, 32. *See also* England.
 Public Schools Athletic League, rules of eligibility, 725.
- Quintilian, quoted, 27, 28.
- Reading, adolescent love for, 307-308.
Realgymnasium, 49, 109, 113, 114, 116; weekly program, 110; and agricultural education, 674. *See also* *Realschule*.
 Realistic schools, characteristics in Renaissance-Reformation period, 44-45.
Realprogymnasium, 108, 112.
Realschule, 47-49, 108, 114, 674. *See also* *Realgymnasium*.
 Recitation vs. class conference, 460.
 Recreation, and moral training, 334-336; socialized, 739.
Reform Gymnasium, 113.
 Reforms in secondary education, 76, 746, 753, 767-774.
 Regents' examinations, proportion of failures, 202.
Reiseprüfung, 116.
 Religious aspects of adolescence, 285-292, 275, note.
 Religious education, 347-353 (outlined, p. xix). *See also* Moral education.
 Renaissance, effect in America, 54; influence on secondary education, 4; interest in Greek, 415; methods of teaching art, 583; use of Latin, 387.
 Reorganization of education, forces now producing, 745; must attack aims first, 750-753; need of, to be understood only through a study of the evolution of present conditions, 11-13, 755; that already accomplished, 746; that still to be accomplished, 746-747, 756; final word upon, 774. *See also* Administration.
- Répétiteurs*, tutors, 91.
 Requirements for college entrance, *see* College entrance requirements.
 Retardation and acceleration, concept of, 248-249; developmental, during adolescence, 292-294.
 Rhetoric, origin, 4; mastery of, a profession, 5; change in content, 29, 30.
 Ribot Parliamentary Committee, 76.
 Richards, C. R., contributor, p. x, Industrial Education, 642-662.
 Richards, Mrs. Ellen H., quoted on necessity for teaching household arts, 623.
 Richter, Jean Paul, quoted on youth and age, 347.
Ritterakademien, 44, 47.
 Robison, C. H., contributor, p. x, Agricultural Education, 671-679.
 Roman contribution to method, 27-29; view of secondary education, 5.
 Roster, daily, for promotion by subject, 177-182.
 Rousseau, first to emphasize importance of adolescence, 9; quoted on adolescence, 246; on moral training, 317; a realist, 51.
 Ruediger, as to transfer of training, 304.
 Rugby, 124.
 Rural high schools, 149-154.
 Russian system of manual training, 661.
- Saint-Cyr, military school at, 439.
 St. Louis Manual Training School, 661.
 St. Paul's, English public school, 124.
 Salaries, England, 135, note; France, 91-92; Germany, 121-122; in Roman schools, 25; in United States, 214. *See also* Administration.
 School, a factor in education, 757, 758, 758-759.
 "School City," 282-283.
 School life, as means of moral training, 338-339; work, as an instrument of moral training, 341-342.
 Schoolmasters' Association of New York and vicinity, 555.
 School plant, wider use of, 738-742.
 School population, England, 137; France, 87, 98; Germany, 111-112; comparative statistics, including United States, 140-141. *See also* Administration.

- Science, *see* Natural sciences.
- Scientific knowledge, not tradition, as basis for educational practice, 745, 747.
- Scientific method, mastery of, as aim of education, 749.
- Scope of secondary education, 1-3.
- Scripture, as to transfer of training, 304.
- Secondary education,
 Definition: in France, 75, 76; in Germany, 107; in England, 134; in United States *vs.* European countries, 71.
- Disagreement as to scope and meaning, 1-3; fundamental importance, 1.
- General characteristics: English, 122-123; English "public" schools, 130; French, 100-101; German, 101-102; United States, 146-148, Chapter XX.
- Historic sketch, 16-64; recent reconstruction of foreign, 76; reorganization needed everywhere, 745-774; is special domain of private schools, 236-237. *See also* Administration; Elementary education; Primary school.
- Secondary school, democratic function, 9, 13; function in social education, 763; diversification of: in Europe, 14; needed in America, 15; begun in United States, 749-750. *See also* Administration; Elementary education; High school; Secondary education; Types of school.
- Secularization of the schools, 347-348; reaction, 348; danger of the secular school, 349.
- Self, realization of the, 327-331.
- Self-activity, essential to intellectual and moral advance, 329-330.
- Self-government in high schools, 189-192, 736; its future, 770; as a means of moral training, 339-341; types of, 282-283. *See also* Discipline.
- Seligman, E. R. A., contributor, p. ix, Economics, 573-574.
- Seminary, 44.
- Sensory development during adolescence, 259-262.
- Seventeenth-century conception of secondary education, 6, 7.
- Sex, characters, primary and secondary, 258; charms and fetishes, 263-264; as determining ideals, 290; development of love, 264-266; hygiene, instruction in, 266-270; instinct, 262-263; relations, and moral training, 336-338.
- Shrewsbury, 124.
- Sisson, E. O., contributor, p. viii, Moral Education in the High School, 313-353.
- Six-year high school, 201, 226-229.
- Smith, D. E., contributor, p. ix, Mathematics, 529-547.
- Smith, Dr. Wm., and King's College, 53.
- Smith Agricultural School, Northampton, Mass., 678.
- Snedden, David, contributor, p. viii, The Curriculum, 214-229; Reorganization of Secondary Education, 745-774.
- Snyder, Edwin R., contributor, p. vii, Rural High Schools, 149-154.
- Social aspects, of adolescence, 272-285; of high school education: content of instruction, 734; extension work, 738-742; methods, 735-736; organization, 736-738; point of view, 732-733; underlying principles, 733. *See also* Humanizing the school; Social education.
- Social economy, effects on education of increasing knowledge of, 745, 746, 747.
- Social education, analysis of aims, 763-764; definition, 759, 762; reorganization based on these aims, 770. *See also* Social aspects of high school education.
- Social individual, as result of education, 764.
- Social nature of adolescent ideals, 291.
- Social sciences, *see* Civics, Economics, History.
- Social selection by secondary school, 7-9; in England, 123-124, 128-129, 130-131; in France, 77; in Germany, 101; in private schools, 241-243.
- Social service, secondary education a preparation for, 14, 15.
- Social station, as determining ideals, 290.
- Societies, high school secret, 279-282, 335; maxims for organizing, 276-277; school, types of, 278-282; 284; self-organized ("gangs"), 275-276; varieties of adult-made, 277-278.
- Society, effect of complexity of modern, 2.
- Sociology, its arguments for and against co-education, 309; moral training through school study of, 345-347. *See also* Social aspects of high school education.
- Somerville school programs showing household arts, 628-629, 631-632.

- Spaulding, Supt., quoted on adjusting education to needs of industry, 196.
- Specialization, in Germany, 112; of high schools, 749-750; among teachers, French custom, 90, 91. *See also* Types of schools.
- Speech, training in oral, 379-392. *See also* Composition; Oratory.
- Spies, system of gymnastics, 700.
- Sprachgefühl*, 425, 431.
- Spring Garden Institute, of Philadelphia, 647.
- Stableton, and sources of energy, 319, 323.
- Stage, the, a factor in education, 757, 758, 760.
- Standards of quality and of degree, great need of, 755.
- Storey, Thomas A., and Meylan, G. R., contributors, p. x, Hygiene and Physical Education, 685-705.
- Strayer, G. D., study of markings given by teachers, 202.
- Strong, Ann G., contributor, p. x, Household Arts, 608-637.
- Structural side of vernacular teaching, 369-370.
- Student advisor system, 193, 194.
- Studia vs. studies*, 342-343.
- Studienanstalt*, 116-118.
- Studies, relative moral value of, 343-346; certain, may be replaced by others as valid aims are formulated, 767.
- Subject matter, its effect on character, 342-374.
- Subjects, relative cost per pupil-hour of recitation, 199.
- Subnormal, attention to, in America, 9.
- Suetonius, quoted on the beginnings of secondary education in Rome, 24-25.
- Sullivan, James, contributor, p. ix, Civics, 565-573.
- Supernormal, attention to, in America, 9.
- Sweden, agricultural education in, 673.
- Swift, on criminal tendencies in adolescence, 295, note.
- Sylvius, Æneas, a tutor, 46.
- Sympathy, in adolescence, 273-274; growth of, during youth, 319-320.
- Syms, and the Latin grammar school, 51.
- Tacitus, quoted on oratory, 26.
- Taylor, Dr. F. W., quoted on relation between principal and board, 212.
- Teacher, as a factor in formal discipline, 305; as an interpreter of literature, 363-373; more interested in subject than in students, 203.
- Teaching congregations suppressed in France, 73.
- Teaching force, in France, 88-91.
- Teachers, assignment of work to, 182-184; conduct of meetings of, 207-208; moral influence: limited by school conditions, 351, potential, 353; number of pupil-hours should determine allotment of work to, 210-211; preparation: in France, 89, 90-100, in Germany, 120-121; qualifications: for household arts, 621-623, for natural sciences, 510-521; scientific measurement of ability, 209-210; teaching only "lessons," 350. *See also* Administration.
- Technical high schools seldom realize vocational ends, 749, 750.
- Technological High School, Cincinnati, 655.
- Tenure of office, French teachers', 92.
- Textbooks, in algebra, 535; in chemistry, how to use, 512; in physical geography, way to use, 479-480. *See also* Administration.
- Textile Department of the Georgia School of Technology at Atlanta, 655.
- Textile School of the Pennsylvania Museum at Philadelphia, 655.
- Thinking powers, development of, as aim of education, 749.
- Thomas, W. Scott, contributor, p. vii, Inspection and Accrediting of Schools, 161-172.
- Thorndike, on transfer of training, 303.
- Thring, of Uppingham, 125; and the classics, 344; and sources of energy, 319, 323, 347.
- Toledo Manual Training School, 66r.
- Traditions, educational, now giving way, 746.
- Training, experimental studies of transfer of, 302-305. *See also* Formal discipline.
- Training of teachers, *see* Teachers, preparation of.
- Travel, as means of education, 46.
- Truancy, one cause for, 271.
- Tuition fees abroad, 72; England, 32, 33, 34, 129, 135, note, 136; in France, 93, 100; in Germany, 112; in high schools, 160-161; in *lycées*, for girls,

- 100; now abolished almost everywhere, 746. *See also* Administration.
- Tuskegee Institute, 678.
- Tutorial education, 45, 46, 50.
- Tutors, duties of French, 91.
- Twiss, G. R., contributor, p. ix, *The Natural Sciences*, 446-521.
- Types of schools, agricultural, 673-678.
- Industrial: apprenticeship, 654; correspondence, 653-654; evening, 647-648; manual training, 648-649; part-time, cooperating with industries, 652-654; preparatory trade, 651-652; secondary technical, 655; technical, 648; technical high, 655-656; trade, 649-651.
- American high, 210-220; High School of Commerce, 668-670; English, 123, 131-132; French, 75, 95; German, 108, 115-116; Greek, 22-24; Middle Ages, 30-31; private, 233-243; Renaissance-Reformation, 38-39, 46-49. *See also* Administration.
- Uniformity in secondary education, 146-148, 747-748; lack of, among German state systems, 102.
- Union School District, developed into high school, 63.
- "Unit" in science work defined, 476.
- United States, agricultural education, 671-672; definition of secondary education, 71; early schools, 51-68; Greek, 418-419; high school organization, 172-229 (outlined, pp. xiv-xvi); high school systems, 146-172; household arts, 632-637; industrial education, 646-658; Latin, 396, 398, 404; manual training, 660-662; modern languages, 432-436; physical education, 702-703. *See also* Universal education.
- United States Department of Agriculture, educational work, 672-673.
- Universal education, beginnings in America, 55; effort to attain secondary, in United States, 67, 68; how obtained in high schools of California, 161; necessary in secondary education as well as in elementary, 14, 15; present demand for, 745; present situation in high schools, 148.
- University, influence on secondary education, 6.
- University Elementary School, of Chicago, 660.
- Variability, characteristic of adolescence, 248; of ideals during adolescence, 291.
- Vernacular, as an element of cultural education, 767; socialized methods in teaching, 735; structural side of teaching the, 369-370. *See also* Composition; Literature.
- Virginia Mechanics Institute of Richmond, 647.
- Visual aids, history, 564-565; Latin and Greek, 406-407; mathematics, 546-547.
- "Vital capacity," training to increase, 256.
- Vittorino, a tutor, 46; and the classics, 344; and spiritual power, 347.
- Vives, on method, 43.
- Vocational education, analysis of aims needed, 761-762; conviction of its necessity, 746; definition, 759; past and present, 757; present demand for, 734; the question of separate administration of, 773; in relation to moral training, 331-334; reorganization based on new aims, 769-770; socialized methods in, 735; scope, 624-632, 641-642. *See also* Agricultural education; Commercial education; Household arts education; Industrial education; Manual training; Vocational schools.
- Vocational guidance, methods not yet satisfactorily formulated, 737; moral effect, 333-334; necessity recognized, Grand Rapids scheme referred to, 201.
- Vocational power as an end of education, 746.
- Vocational schools, private, 237-239; slow development in United States, 7; suitable courses in history for, 558. *See also* Vocational education.
- Voice, changes during adolescence, 256; hygiene and training, 256.
- Wagner, Charles, quoted, on adolescent love, 337; on sexual purity, 336-337.
- Washington University and the St. Louis Manual Training School, 661.
- Weight, increase during adolescence, 250-252.
- Wellington, Duke of, and Waterloo, 124.
- Westminster, English public school, 124.
- Whipple, G. M., contributor, p. viii, *Psychology and Hygiene of Adolescence*, 246-310.

- Will, develops only through its own activity, 313-314, 320; finds exercise only in problems, 317-318, 320; influences intellectual growth, 315-316.
- Williamson Free School of Mechanical Trades, 649.
- Winchester, 124.
- Winona Agriculture and Technical Institute, Ind., 678.
- Wissenschaftliche Prüfungs-Kommissionen*, 104.
- Woman's movement, educational aspect of, 15.
- Woodward, Dr. C. A., and the St. Louis Manual Training School, 660.
- Woodworth, R. S., on transfer of training, 303.
- Worcester Girls' Industrial School, 624-626.
- Workingmen's School of the Ethical Culture Society, New York, 660.
- Workshop, a factor in education, 757, 758, 760.
- Young, Prof. J. W., definition of mathematics, 520.
- Young Men's Christian Association, bicycling trips, 272; and technical instruction, 647.
- Zest of life, 334-336.
- Zoölogy, *see* Biology.

THE following pages contain advertisements of
books by the same author or on kindred subjects.

BY THE SAME AUTHOR

A Text-Book in the History of Education

By PAUL MONROE

Professor of the History of Education, Teachers College, Columbia University

Cloth, crown 8vo, xxiii + 772 pages, \$1.90 net

The aim of this book is to emphasize the great typical educational movements in thought and practice, and to give the student very definite conceptions of comparatively few leaders rather than to treat a multiplicity of more or less unrelated facts and a multitude of men with diverse ideas. In each general topic treated, enough material is given to elucidate the main characteristics. The contributions of two or three of the most representative men are discussed for the same purpose. Since the restrictions of space and the working plan of the author forbid further elaboration, the text at almost every point is suggestive rather than exhaustively conclusive. A selected bibliography and a series of questions or suggestive topics accompany each chapter, to assist the student in further study. Chronological tables are given in connection with the more important historical periods, so that the student may get a conspectus of the period under consideration, and the relation of the educational to other aspects of historical development. A detailed analysis of the book aids in preserving a correct perspective and the proper relationship between the various topics. The numerous illustrations add a realistic touch to the discussion of the more practical aspects of the subject.

Brief Course in the History of Education

By PAUL MONROE, PH.D.

Cloth, 12mo, xviii + 409 + iv pages, \$1.25 net

This condensation of *A Text-Book in the History of Education* has been prepared to meet the demands of normal and training schools and of those colleges that have not sufficient time at their disposal to master the contents of a larger text. While the text at every point aims to be *suggestive rather than exhaustive*, even in this abbreviated form the volume contains more material than most other texts on the subject. The methods of presentation are the same as in the larger work.

A Source Book of the History of Education

FOR THE GREEK AND ROMAN PERIOD

By PAUL MONROE

Cloth, 8vo, xiii + 515 pages, \$2.25 net

THE MACMILLAN COMPANY

Publishers

64-66 Fifth Avenue

New York

A Cyclopeda of Education

EDITED BY PAUL MONROE, PH.D.

Professor of the History of Education, Teachers College, Columbia University;
Author of "A Text-Book in the History of Education," "Brief
Course in the History of Education," etc.

Now completed in five volumes. Sold only by subscription.

Price \$5.00 per volume.

The need of such work is evidenced: By the great mass of varied educational literature showing an equal range in educational practice and theory; by the growing importance of the school as a social institution, and the fuller recognition of education as a social process; and by the great increase in the number of teachers and the instability of tenure which at the same time marks the profession.

The men who need it are: All teachers, professional men, editors, ministers, legislators, all public men who deal with large questions of public welfare intimately connected with education — every one who appreciates the value of a reference work which will give him the outlines of any educational problem, the suggested solutions, the statistical information, and in general the essential facts necessary to its comprehension.

Among the departmental editors associated with Dr. Monroe are Dr. ELMER E. BROWN, U. S. Commissioner of Education, Prof. E. F. BUCHNER, of Johns Hopkins, Dr. WM. H. BURNHAM, Clark University, M. GABRIEL COMPAYRÉ, Inspector-General of Public Instruction, Paris, France, Prof. WILHELM MÜNCH, of Berlin University, Germany, Prof. JOHN DEWEY, of Columbia University, Dr. ELLWOOD P. CUBBERLY, Stanford University, Cal., Prof. FOSTER WATSON, of the University College of Wales, Dr. DAVID SNEDDEN, Commissioner of Education for the State of Massachusetts, and others.

Send for a descriptive circular and list of contributors

THE MACMILLAN COMPANY

Publishers

64-66 Fifth Avenue

New York

COMMENTS ON THE CYCLOPEDIA OF EDUCATION

"The appearance of the first volume undoubtedly marks an epoch in the development of our educational literature."—ELMER E. BROWN, U. S. Commissioner of Education.

"Sets of it ought to be in every school library, city and country, and in every public library, even though small."—ELLWOOD P. CUBBERLY, Professor of Education, Leland Stanford University.

"To one who is interested in problems of education it is a work of great value and interest."—J. H. COLLINS, Superintendent City Schools, Springfield, Illinois.

"The work includes every aspect of education. Here is found, not only the information required in a handy reference book of cyclopedic range, but also an assemblage of systematic treatises on every phase of the subject."—*The Outlook*.

"The present publication meets a real need and will be heartily welcomed, especially since its merit entitles it to approval as a worthy companion of the German and French educational encyclopedias."—*N. Y. Post*.

"Our warmest thanks are due for this 'open sesame,' this godsend to all educators."—*New York Sun*.

"From the subjects chosen at random as samples of the manner in which the articles have been written it is gratifying to note that in aiming at conciseness there has been no sacrifice of clearness or precision."—*San Francisco Chronicle*.

"This is a masterly work, one long needed, and one that will be keenly appreciated."—*Journal of Education*.

THE MACMILLAN COMPANY

Publishers

64-66 Fifth Avenue

New York

By JOHN FRANKLIN BROWN, PH.D.

Formerly Professor of Education and Inspector of High Schools for the
State of Iowa

The American High School

Cloth, 12mo, 462 pages, \$1.40 net

"The American High School," by John Franklin Brown, Ph.D., is based upon sound social and psychological principles, and will be found direct, sane, and practical. In a brief historical chapter the author shows how the high school came to be what it is, and then passes to a consideration of its function, the programme of studies, equipment, the teacher, the pupil, class exercises, athletics, and other equally pertinent topics. In the chapter upon "Present Problems and Future Development" he emphasizes the pressing needs of the day and indicates a line of progress. A well-selected bibliography of several hundred titles furnishes the basis for further study and is an exceedingly valuable feature of the work. The following is a condensed table of contents:

I. Historical. II. The Function of the High School. III. The Programme of Studies. IV. Organization and Management. V. Material Equipment. VI. The Teacher. VII. The Principal. VIII. The Pupil. IX. The Class Exercise. X. Government. XI. Social Life. XII. The High School and the Community. XIII. Present Problems and Future Development.

The Training of Teachers for Secondary Schools in Germany and the United States

Cloth, 12mo, \$1.25 net

Dr. Brown has served in a Prussian Oberrealschule as exchange teacher of English from the United States. He has made a special study of German secondary schools and particularly of the methods of training teachers for them. His official position gave him unusual advantages for observation and for gathering information. In Part I of the new book he has given a brief historical account of the certification and training of German secondary school teachers, together with a more extended account of existing laws, institutions, and methods. There is also a chapter on his impressions of the German system. In Part II is given briefly an account of existing laws concerning the certification of high school teachers in the various states of the United States and of the institutions for the training of secondary school teachers. This is followed by the discussion of a much needed higher standard of training in the United States, and the presentation of a feasible plan for the training of American teachers. This plan, which, in the author's opinion, includes the best features of both the German and the American system, requires coöperative effort on the part of college and secondary school under the supervision of the state.

THE MACMILLAN COMPANY

Publishers

64-66 Fifth Avenue

New York

The American Secondary School And Some of Its Problems

BY JULIUS SACHS, PH.D.

Professor of Secondary Education in Teachers College, Columbia University

Cloth, 12mo, \$1.10 net

EXTRACT FROM THE PREFACE

It has been realized by the author that it is wiser to concentrate attention upon some of the problems of the secondary school and indicate their significance rather fully, than to compass all, or even a majority, of the questions that attach themselves to our system of middle schools. He has subordinated all questions of method, of curriculum, to what has appeared to him the determining factor in a secondary school system, the fitness of the teacher for his task; the book has, in consequence, become an appeal to and for the teacher. It traverses many topics which other writers have found it necessary to elaborate into special treatises; the value of these he does not disparage, though he thinks their appeal might often with profit be presented more compactly.

In accord with this dominating thought, there have been added to the body of this book, besides two excurses, a series of outlines on The Teaching of several subject groups in the Secondary School Course; their object is to rouse the individual teacher to such study of his chosen field as will give him the widest possible survey of the questions involved in the presentation of the subject.

CONTENTS

PART I

The Teacher.

PART II

Chapter I. The Present Status of the Public High School.

Chapter II. The Private Secondary School.

Chapter III. The Educational Policy of the Secondary School.

Excursus I. The Continuation School.

Excursus II. The Function of the Educational Expert.

Appendix: Outlines for the Teaching of Certain Subject Groups in the Secondary School Course.

THE MACMILLAN COMPANY

Publishers 64-66 Fifth Avenue New York

Principles of Secondary Education

BY CHARLES DE GARMO

Professor of the Sciences and Art of Education in Cornell University

IN THREE VOLUMES

Volume I. Studies. (New and Enlarged Edition) 12mo, \$1.25 net

Volume II. Processes of Instruction 12mo, \$1.00 net

Volume III. Ethical Training 12mo, \$1.00 net

VOLUME I.—“In his treatment of the studies in secondary school instruction the various chapters deal with the Bases for Selection; Classification of Studies into Convenient Groups; Function and Relative Educational Worth of the Studies and Study Groups; and the Organization of Studies into Curricula. Under each of these subdivisions the treatment is exhaustive, lucid and fair, the author avoiding novelties and efforts at contributions, restricting the book to exposition and to argument that grows naturally out of analysis.”—*Education, Review of First Edition.*

The appendices of the first Edition have been omitted and six chapters upon “Basic Ideals for Educational Progress” added. These consider progress in education from the following standpoints: prosperity, health, general or cultural education, special or vocational education, eugenics and euthenics, and the reciprocal relations that should exist between individuals and social groups.

VOLUME II.—“The first section of the volume is devoted to an examination of the scientific basis for high school methods; the three topics discussed are the acquisition of facts, the meaning of facts, and forms of solution for the problem. The second part treats of scientific method in high school instruction. . . .”—*Atlantic Journal of Education.*

VOLUME III.—“The author blazes a trail through ethical theory in order that the regulative principles of moral conduct may be made clear and unmistakable to the young.

“To secure the completest possible utilization of the agencies for ethical training now available to the American High School is the dominating purpose of the whole work.”

THE MACMILLAN COMPANY

Publishers

64-66 Fifth Avenue

New York



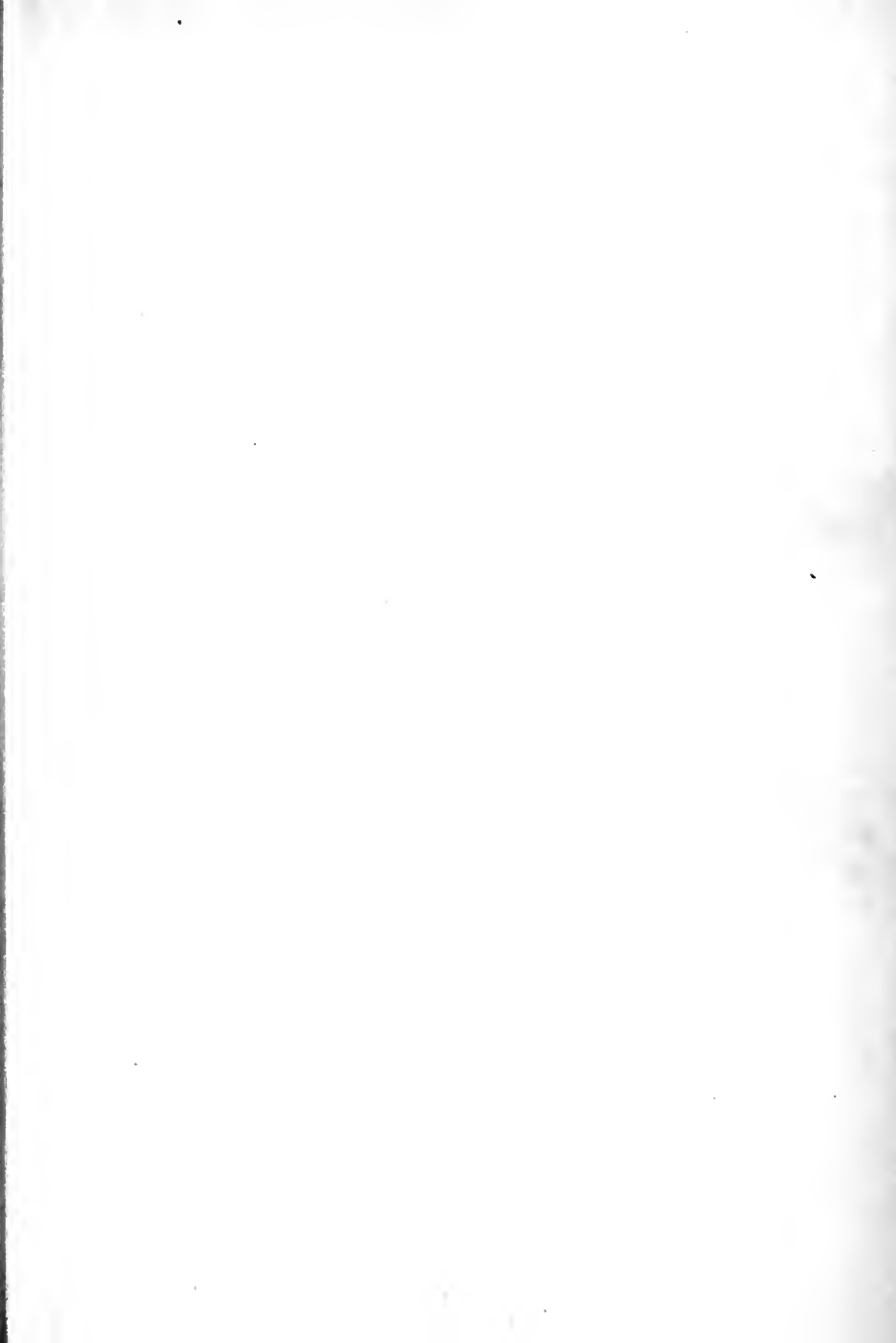

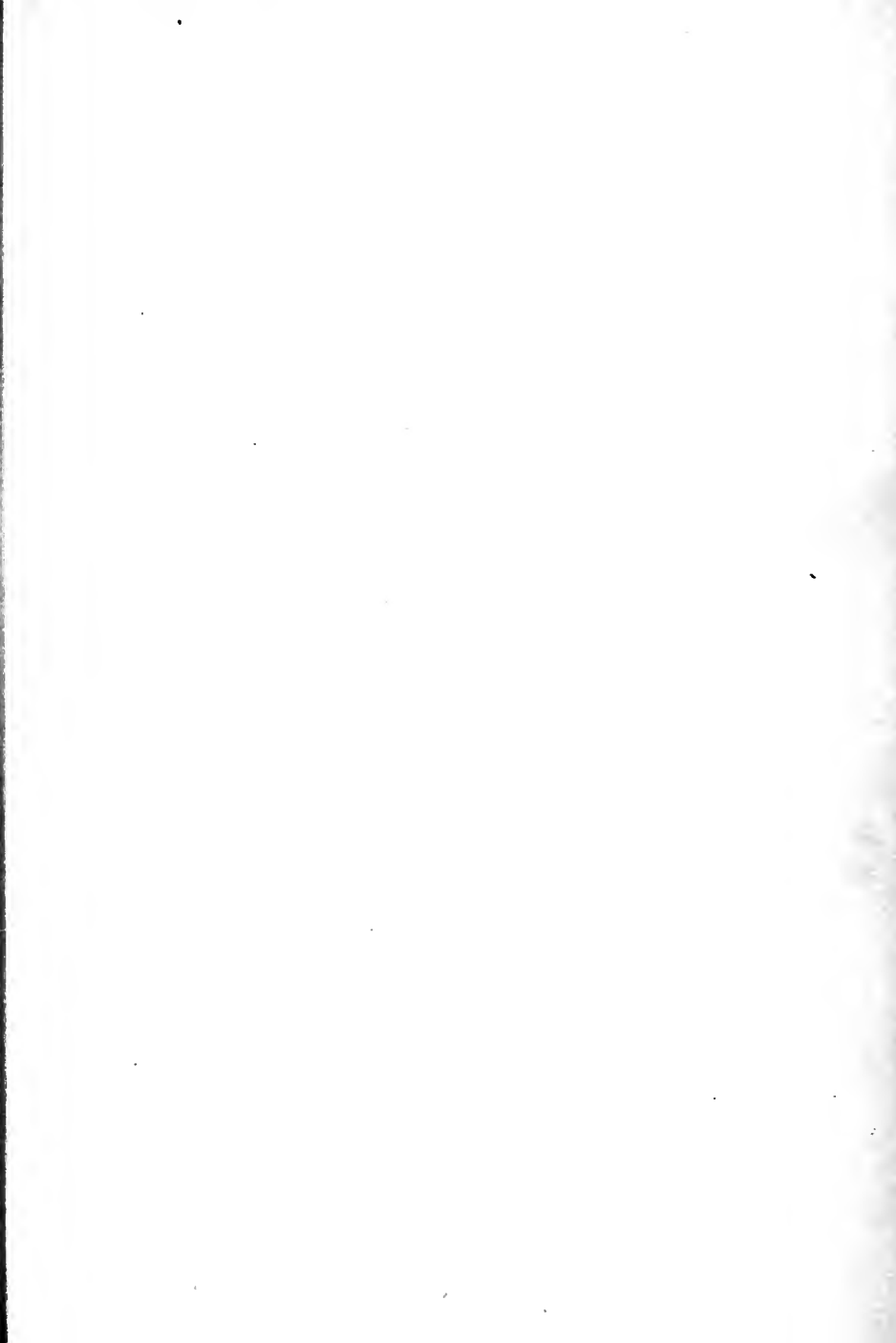



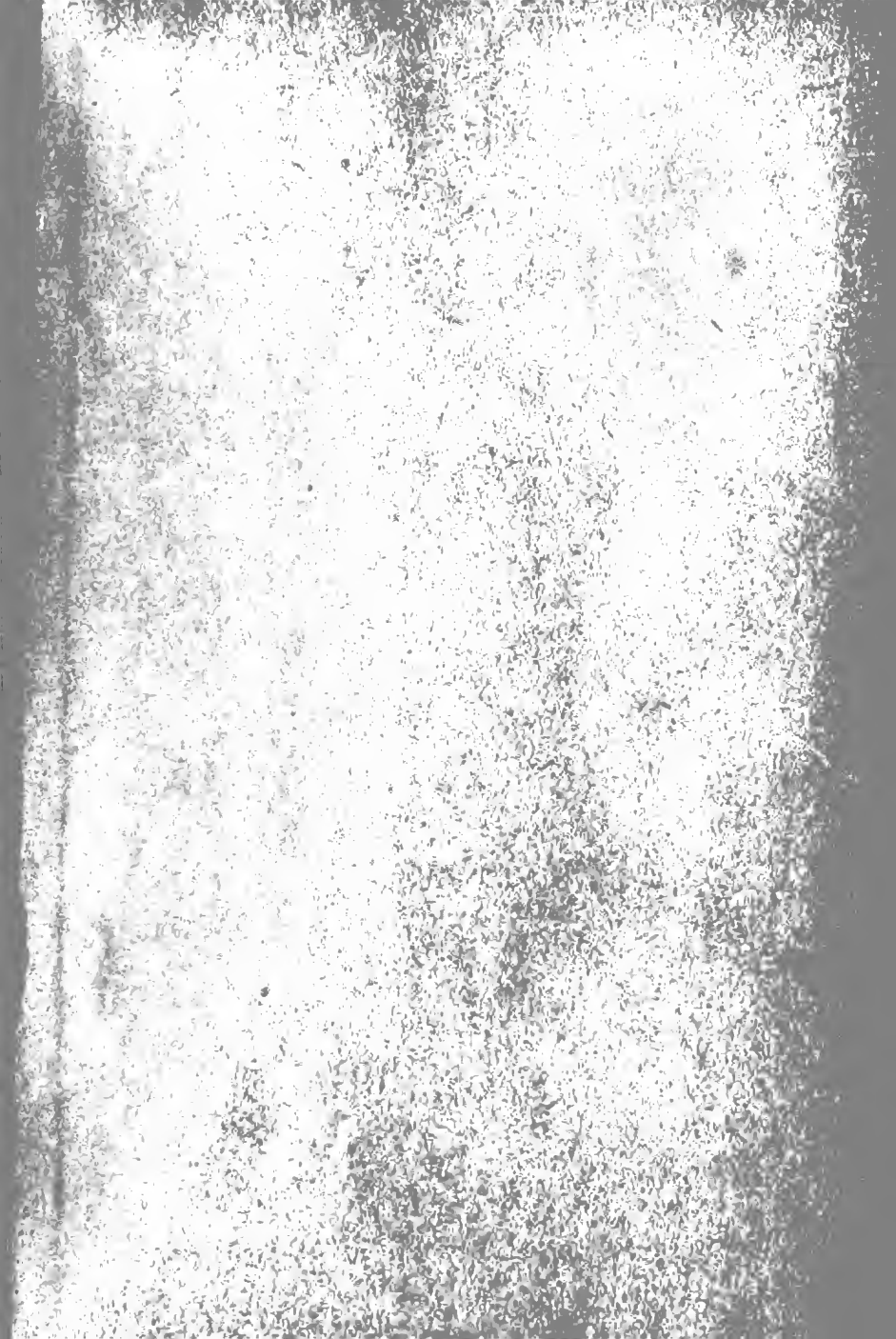



135714.

Educ.

Author Monroe, Paul. [ed.]

Title Principles of secondary education.

UNIVERSITY OF TORONTO
LIBRARY

Do not
remove
the card
from this
Pocket.

Acme Library Card Pocket
Under Pat. "Ref. Index File."
Made by LIBRARY BUREAU

