

9
F6F63 2

41-3
81

451669
Smith
13

PROCEEDINGS
of the
Florida Academy
of
Sciences
for
1936

VOL. I

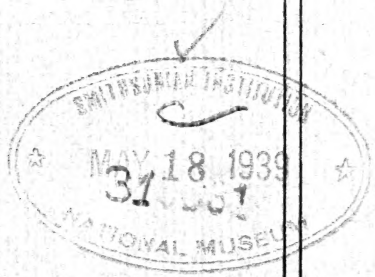

Published by the Academy
1937

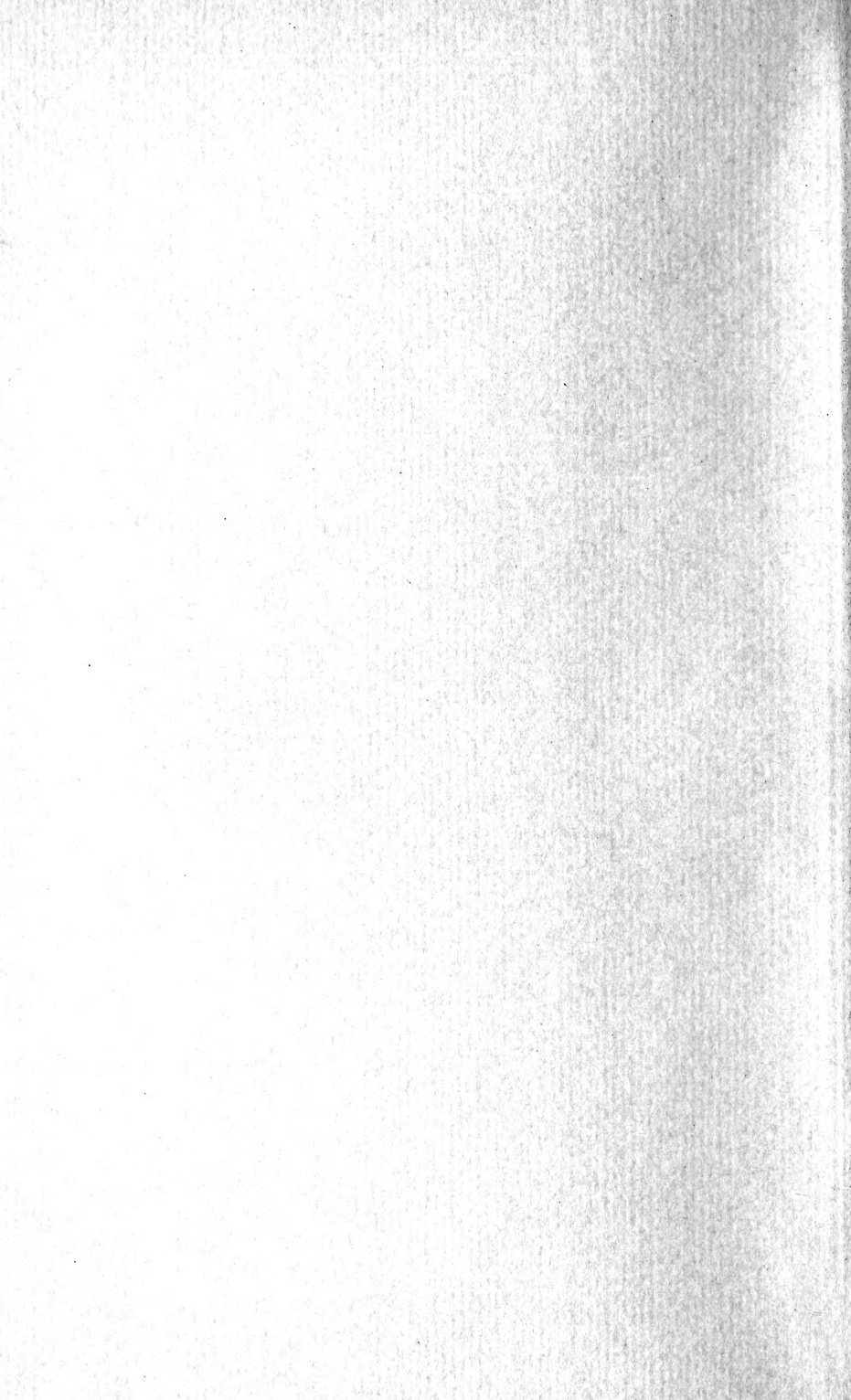

PROCEEDINGS,
of the
Florida Academy
of
Sciences,
for
1936

VOL. I

Published by the Academy

1937

THE PROCEEDINGS OF THE FLORIDA ACADEMY OF SCIENCES are issued annually under the direction of the Council of the Academy acting through the Editor, the Business Manager and the Committee on Publications.

For this volume these officers are:

<i>Editor</i>	T. H. HUBBELL
<i>Business Manager</i>	R. S. JOHNSON

THE COMMITTEE ON PUBLICATIONS

T. H. HUBBELL (University of Florida) Chairman, *ex officio*
R. I. ALLEN (John B. Stetson University)
J. F. BASS, Jr. (Bass Biological Laboratories)
H. W. CHANDLER (University of Florida)
HERMAN GUNTER (State Board of Conservation)
HERMAN KURZ (Florida State College for Women)
B. P. REINSCH (Florida Southern College)

THE PROCEEDINGS are sent to all members of the Academy and are available for exchange. The price of this volume, paper bound, is \$1.00. Orders and correspondence are handled by the Secretary, J. H. Kusner, University of Florida, Gainesville, Florida.

00.73
FGFG3

CONTENTS

The Academy During 1936.—J. H. KUSNER, <i>Secretary</i>	1
The Achievement Medal.....	3
Treasurer's Report.....	3
Program of the Inaugural Meeting at Gainesville.....	3
Program of the First Annual Meeting at DeLand.....	5

PAPERS

Opportunities for Research in Florida. Address of Dr. HERMAN KURZ, <i>Retiring President</i>	7
The Nature of Scientific Papers.—R. F. BELLAMY.....	17
The Freeze of 1934.—GRAY SINGLETON.....	23
Some Consequences of Pseudo-Mathematics and Quasi-Measurement in Psychometrics, Education and the Social Sciences.—CHRISTIAN P. HEINLEIN..	33
Recent Advances in the Field of Vitamin Chemistry.—L. L. RUSOFF.....	42
Cohering Keels in Amaryllids and Related Plants.—H. H. HUME.....	48
Growth-Ring Studies of Trees of Northern Florida.—W. L. MACGOWAN.....	57
Studies on the Life Zones of Marine Waters Adjacent to Miami, I. The Distribution of the Ophiuroidea.—JAY F. W. PEARSON.....	66
A Key to the Fresh-Water Fishes of Peninsular Florida.—A. F. CARR, JR.....	72
The Gulf-Island Cottonmouths.—A. F. CARR, JR.....	86
An Annotated List of the Birds of Alachua County, Florida.—R. C. McCLANAHAN.....	91
A ⁴ List of the Recent Land Mammals of Florida.—H. B. SHERMAN.....	102
The Analysis of Plant Ash in the Light of the Law of Definite Proportions: An Apparently Forgotten Principle in Chemical Analysis.—L. W. GADDUM...	128
Cellulose of Spanish Moss.—LOUIS E. WISE and A. MEER.....	131

ABSTRACTS: Application of Helley's Theorem to Sequences of Jordan Curves, by DONALD FAULKNER; The Methods of Multiple Factor Analysis, by CHARLES I. MOSIER; A Quantitative Method for the Determination of Minute Quantities of Copper in Biological Materials, by L. L. RUSOFF and L. W. GADDUM; Results of Some Further Studies of the Spectrographic Determination of Zinc, by L. H. ROGERS and O. E. GALL; Absorption Spectrophotometry and its Applications, by L. H. ROGERS; An Application of Infra-Red Spectroscopy to Rubber Chemistry, by DUDLEY WILLIAMS; Raman Spectra of Acetone, by R. C. WILLIAMSON; Some Recent Developments in High-Fidelity Sound Reproduction, by ROBERT I. ALLEN; The Interrelation of Motor Abilities, by P. F. FINNER; Effect of a Lack of Vitamin A on the Blood Picture of Rats and Adult Humans, by O. D. ABBOTT and C. F. AHMANN; The Effect of Certain Environmental Factors on the Development of Cotton Seed, Germinating Ability, and Resultant Yield of Cotton,

by W. A. CARVER; Organography of Sixteen Millimeter *Ameiurus*, by NELLE CAMPBELL; Inheritance of Rest Period in Peanut Seeds, by FRED H. HULL; Genetics in the Taxonomy of *Arachis hypogaea* L., by FRED H. HULL; Non-effective Gene Frequencies, by FRED H. HULL; Some Florida Crawfishes and their Habitat Distribution, by H. H. HOBBS; Two Larval Crane-fly Members of the Neuston Fauna, by J. SPEED ROGERS; The Past and Present Status of Some Rare and Threatened Florida Birds, by ALDEN H. HADLEY; Comments on the Mammals of Florida, by E. V. KOMAREK; Effects of X-rays on Corn, by A. A. BLESS; The Place of Mathematics in Modern Socialized Education, by BARBARA DAVIS; Proverbs in Browning's *The Ring and the Book*, by CORNELIA M. SMITH..... 145

List of Officers and Members.....	159
Charter and By-Laws.....	168



HERMAN KURZ

FIRST PRESIDENT OF THE FLORIDA ACADEMY OF SCIENCES

THE ACADEMY DURING 1936

IN JANUARY of 1936, after some informal discussion, the following eleven individuals constituted themselves an organization committee to take steps toward the formation of a Florida Academy of Sciences:

A. A. Bless (Physics), C. F. Byers (Biology), L. W. Gaddum (Biochemistry), T. H. Hubbell (Biology), F. H. Hull (Genetics), J. H. Kusner (Mathematics and Astronomy), J. S. Rogers (Biology), H. B. Sherman (Biology), J. R. Watson (Entomology), R. C. Williamson (Physics), all at the University of Florida, and H. Kurz (Botany), Florida State College for Women.

After studying the form of organization of other Academies, the committee prepared a proposed constitution and set of by-laws, and issued a call for an organization meeting, inviting such other workers in the sciences as were known by the members of the committee to be interested in establishing an Academy. The meeting was held at the University of Florida in Gainesville on February 6, 1936, there being about thirty workers in the sciences from various parts of the state present. A constitution and a set of by-laws were adopted and an application for a charter as a non-profit corporation under the laws of Florida was signed by those present. Officers to function until the first annual meeting were elected as follows:

President—Dr. Herman Kurz (Botany), Florida State College for Women.

Vice-President—Dr. R. C. Williamson (Physics), University of Florida.

Secretary—Dr. J. H. Kusner (Mathematics and Astronomy), University of Florida.

Treasurer—Dr. J. F. W. Pearson (Zoology), University of Miami.

On February 24, 1936, the charter application, containing 92 signatures of science workers from all parts of Florida, was filed with the Circuit Court at Gainesville, and the charter was granted.

In April, 1936, the Council of the Academy authorized the formation of a Physical Sciences Section, electing Herman Gunter, State Geologist, as chairman, and a Biological Sciences Section, electing Dr. H. H. Hume (Botany), University of Florida, as chairman. Also, Dr. T. H. Hubbell (Biology), University of Florida was elected Editor of the PROCEEDINGS.

On May 8 and 9, 1936, the Inaugural Meeting of the Academy was held at the University of Florida, with about 100 members in attendance. In two general sessions, 21 papers were presented by members of the Academy. At the banquet held in connection with the meeting, the Inaugural Address, *Academies of Science and the Cooperative Spirit in Scientific Research** was delivered by Dr. C. A. Browne, Supervisor of Research, Bureau of Chemistry and Soils, United States Department of Agriculture, as the official representative of both the Department of Agriculture and the American Association for the Advancement of Science. An address of welcome was made by Dr. Jno. J. Tigert, President of the University of Florida, and a response was made by Dr. H. H. Hume for the Academy.

In October of 1936, the Academy was granted affiliation with the American Association for the Advancement of Science.

The Annual Meeting was held at Stetson University in DeLand, on November 20 and 21, 1936, with about 125 members present. Papers were presented as follows: in the Biological Sciences Section—8 papers; in the Physical Sciences Section—5 papers; in two general sessions—14 papers. At the banquet, Dr. W. S. Allen, President of Stetson University, delivered an address of welcome, and Dr. Herman Kurz presented his retiring presidential address *Opportunities for Research in Florida*.†

The Nominating Committee, consisting of Dr. Cornelia Smith (Stetson) Chairman; J. F. Bass, Jr. (Bass Biological Laboratories); Dr. R. F. Bellamy (Florida State College for Women); Prof. J. H. Clouse (Miami); Dean W. E. DeMelt (Southern); Dr. J. S. Rogers (University of Florida); Prof. R. F. Webb (Tampa); Prof. E. F. Weinberg (Rollins); reported nominations which resulted in the election of the following officers for 1937:

President—Dr. H. H. Hume (Botany), University of Florida.

Vice-President—Dr. Jennie Tilt (Home Economics), Florida State College for Women.

Secretary—Dr. J. H. Kusner (Mathematics and Astronomy), University of Florida.

Treasurer—Dr. J. F. W. Pearson (Zoology), University of Miami.

Chairman, Biol. Sci. Section—E. P. St. John, Floral City.

Chairman, Phys. Sci. Section—Prof. J. A. Spurr, Rollins College.

Subsequently, the Council voted to hold the 1937 Annual Meeting at the University of Miami on November 19 and 20.

—J. H. KUSNER, *Secretary*

* Subsequently published in *Science*, July 3, 1936, Vol. 84, No. 2166, pp. 1-7.

† See pages 7 to 16 of this volume.

THE ACHIEVEMENT MEDAL

IN SEPTEMBER of 1936, Phipps and Bird, Inc. of Richmond, Virginia generously offered to give the Academy a gold medal every year to be awarded to a member of the Academy for the presentation of a noteworthy paper at the annual meeting. Similar medals have been presented by the same company to other Academies in the Southeast. The Council accepted this kind offer and the medal was subsequently named "The Achievement Medal of the Florida Academy of Sciences."

A committee was appointed to make the award for the 1936 Annual Meeting. It consisted of Prof. J. H. Clouse (Physics) University of Miami; Mr. J. F. Bass, Jr. (Zoology) Bass Biological Laboratories, Englewood; Dr. R. F. Bellamy (Anthropology) Florida State College for Women; Dr. L. W. Gaddum (Biochemistry) University of Florida; Dr. Herman Kurz (Botany) Florida State College for Women.

The Achievement Medal for 1936 was awarded to Dr. H. H. Hume (Botany) University of Florida, for his paper: "Cohering Keels in Amaryllids and Related Plants."

TREASURER'S REPORT

Receipts from dues, etc. to November 16, 1936.....	\$356.00
Disbursements for printing, postage, etc. to November 16, 1936.....	53.00
	<hr/>
Cash on Hand, November 16, 1936.....	\$303.00

—J. F. W. PEARSON, *Treasurer*

PROGRAM OF THE INAUGURAL MEETING

AFTERNOON SESSION, FRIDAY, MAY 8, 1936

PRESENTATION OF PAPERS: President Herman Kurz presiding.

1. The Nature of Scientific Papers.—R. F. Bellamy, Florida State College for Women.
2. The Present Status of the International Commission on Zoological Nomenclature.—C. W. Stiles, Rollins College.
3. Inheritance of Rest Period in Peanut Seeds.—F. H. Hull, University of Florida.
4. The Effect of X-rays upon the Growth of Seeds.—A. A. Bless, University of Florida.
5. Comments on Problems in the Mammals of Florida, and: Comments on the Recent Mammals of Florida.—E. V. Komarek, Thomasville, Ga.
6. Concerning the Migration of Bats in the Region of Gainesville, Florida.—H. B. Sherman, University of Florida.
7. A Quantitative Method for the Determination of Minute Amounts of Copper in Biological Materials.—L. L. Rusoff and L. W. Gaddum, University of Florida.

8. The Requirements of an Accredited School of Forestry.—H. S. Newins, University of Florida.
9. The Gulf-Island Cottonmouths.—A. F. Carr, University of Florida.
10. The Interrelation of Motor Abilities.—P. F. Finner, Florida State College for Women.
11. Spectroscopic Sidelights on Molecular Structure.—R. C. Williamson, University of Florida.
12. Some Florida Crawfishes and their Habitat Distribution.—H. H. Hobbs, University of Florida.
13. A Limnological Reconnaissance of some Lakes, Ponds and Streams of Northern Florida.—J. Speed Rogers, University of Florida.

BANQUET AT THE HOTEL THOMAS

Toastmaster: Herman Kurz, President of the Academy.

Address of Welcome:

Jno. J. Tigert, President, University of Florida.

Response and Introduction of Inaugural Speaker:

H. H. Hume, Assistant Director, Research, Experiment Station, University of Florida.

Guest Speaker, as Official Representative of the American Association for the Advancement of Science:

C. A. Browne, Supervisor of Research, Bureau of Chemistry and Soils, U. S. Department of Agriculture.

Inaugural Address: Academies of Science and the Cooperative Spirit in Scientific Research.

SATURDAY, MAY 9, 1936

PRESENTATION OF PAPERS: President Herman Kurz presiding.

1. The Habits and Distribution of a Rare Florida Dragonfly.—C. F. Byers, University of Florida.
2. The Food and Feeding Habits of two Florida Frogs.—J. D. Kilby, University of Florida.
3. A Geological Explanation of the Distribution of Tropical Ferns in Florida.—E. P. St. John, Floral City.
4. Results of Some Further Studies of the Spectrographic Determination of Zinc.—L. H. Rogers and O. E. Gall, University of Florida.
5. The Crystal Structure of Calcium Chromate.—J. H. Clouse, University of Miami.
6. Growth Behavior of Plants as Affected by Cultural Practices.—W. A. Leukel, University of Florida.
7. The Analysis of Plant Ash in the Light of the Law of Definite Proportions: An Apparently Forgotten Principle in Chemical Analysis.—L. W. Gaddum, University of Florida.

8. A Peculiar Spider, *Cyclocosmia truncata* (Hentz), in Florida.—H. K. Wallace, University of Florida.

TRANSACTION OF BUSINESS—11:30 to 12 noon.

PROGRAM OF THE FIRST ANNUAL MEETING

FRIDAY, NOVEMBER 20, 1936

GENERAL SESSION

PRESENTATION OF PAPERS: President Herman Kurz presiding

1. The Past and Present Status of Some Rare and Threatened Florida Birds—Alden H. Hadley, Gainesville, Florida.
2. Effect of a Lack of Vitamin A on the Blood Picture of Rats and Adult Humans—O. D. Abbott and C. F. Ahmann, University of Florida.
3. Growth-Ring Studies of Trees of Northern Florida—W. L. MacGowan, Lee High School, Jacksonville.
4. The Methods of Multiple Factor Analysis—Charles I. Mosier, University of Florida.
5. Recent Progress in High-Fidelity Sound Reproduction—Robert I. Allen, Stetson University. (Demonstrations by Clifford Ryerson.)
6. Non-Effective Gene Frequencies—Fred H. Hull, University of Florida.
7. Absorption Spectrophotometry and Its Applications—L. H. Rogers, University of Florida.
8. Recent Advances in the Field of Vitamin Chemistry—L. L. Rusoff, University of Florida.
9. Proverbs in Browning's *The Ring and the Book*. The Scientific Method Applied to a Problem in English Literature—Cornelia M. Smith, Stetson University.
10. Damage to Citrus by Freeze of December, 1934—Gray Singleton, Federal Land Bank, Columbia, S. C.

BANQUET

Toastmaster: R. C. Williamson, Vice-President of the Academy.

Address of Welcome:

W. S. Allen, President, John B. Stetson University.

Retiring Address:

Herman Kurz, President of the Academy.

SATURDAY, NOVEMBER 21

GENERAL SESSION

PRESENTATION OF PAPERS: Present Herman Kurz presiding

1. The Effect of Certain Environmental Factors on the Development of Cotton Seed, Germinating Ability, and Resultant Yield of Cotton—W. A. Carver, University of Florida.

2. Some Consequences of Pseudo-Mathematics and Quasi-Measurement in Psychometrics, Education and the Social Sciences—Christian P. Heinlein, Florida State College for Women.
3. Effects of X-rays on Corn—A. A. Bless, University of Florida.
4. Has the Study of Mathematics a Place in Modern Socialized Education?—Barbara Davis, Stetson University.

BIOLOGICAL SCIENCES SECTION

PRESENTATION OF PAPERS: H. H. Hume, Section Chairman, presiding

1. Two Larval Crane-fly Members of the Neuston Fauna—J. Speed Rogers, University of Florida.
2. Studies on the Life Zones of Marine Waters Adjacent to Miami: I. The Distribution of the Ophiuroidea—Jay F. W. Pearson, University of Miami.
3. Organography of Sixteen Millimeter Ameiurus—Nelle Campbell, Stetson University.
4. Cohering Keels in Amaryllids and Related Plants—H. H. Hume, University of Florida.
5. List of the Recent Land Mammals of Florida—H. B. Sherman, University of Florida.
6. Genetics in the Taxonomy of *Arachis Hypogaea*, L.—Fred H. Hull, University of Florida.
7. A Key to the Freshwater Fishes of Peninsular Florida—A. F. Carr, Jr., University of Florida. By Title.
8. An Annotated List of the Birds of Alachua County—R. C. McClanahan, Pensacola High School. By Title.

PHYSICAL SCIENCES SECTION

PRESENTATION OF PAPERS: Herman Gunter, Section Chairman, presiding

1. The Solution of A. C. Problems by Means of Complex Numbers—Jess Armstrong, Landon High School, Jacksonville.
2. Raman Spectra of Acetone—Water Solutions—R. C. Williamson, University of Florida.
3. Cellulose of Spanish Moss—Louis E. Wise, Rollins College, and A. Meer, Rollins College.
4. An Application of Infrared Spectroscopy to Rubber Chemistry—Dudley Williams, University of Florida.
5. Application of Helley's Theorem to Sequences of Jordan Curves—Donald Faulkner, Stetson University. By Title.

BUSINESS SESSION

OPPORTUNITIES FOR RESEARCH IN FLORIDA

Address by
HERMAN KURZ, Retiring President

BY-PRODUCTS OF RESEARCH ACTIVITY

A GOOD MANY of us present are primarily teachers. For our benefit and as an introduction I want to point out at once that an instructor's development should not stop with the attainment of his higher degree. This development should be a continual process. Most of our inspiring teachers are creative scholars. Someone has said that they inspire their students because they bring nuggets fresh from the mines. Doing research, even in a modest way, develops an open-mindedness, a desire for caution, and a humility that we seldom see on the part of those who have taught from the books, and only from the books, all their lives.

Discussions with critical colleagues or appearing before an informed audience will no doubt improve the quality of our creative efforts. Pertinent and searching questions on the part of experts in the same field will tend to produce a more cautious or sounder view of our problems or fields. To one accustomed to appear only before undergraduate students and whose word is there unquestioned, there is nothing so helpful as a doubt or contradiction expressed on the part of an informed fellow scientist.

In the modern day when even high schools are demanding M.A. and Ph.D. degrees it becomes almost imperative that college teachers be trained in research methods. The modern tendency even in the grammar school is to teach by the project or the research method. Procurement in itself of a Master's or a Doctor's degree hardly suffices to give adequate training for those who intend to train for the higher degree. In present day college training, a mastery of English is being more and more emphasized. Proper marshalling and treatment of facts is one of the very essences of good English. Ironically enough, many college teachers themselves are unable to write a thesis that will stand unshaken by the pen of a critical editor. I believe I can say without contradiction that creative writing is conducive to good writing; and, researches in the sciences offer excellent opportunities for productive writing. One director of research recently said to me that he could spend a month laying out research problems awaiting solution in Florida. In this discourse I shall attempt therefore to indicate merely some of the opportunities and demands for research in the State.

To begin with, I believe that it must be perfectly apparent to everybody that problems essentially sociological or involving racial considerations should be studied by investigators who through birth and rearing as well as training are familiar with the local or regional traditions and background. We can hardly expect those brought up and trained in other sections of the country to make a cursory trip into Florida, spend a few weeks or months, and then on the basis of this brief study be able to make any real or great contribution on problems involving race, creed, or traditions.

LOCAL FLORAS AND FAUNAS

Florida has 3500 species of seed plants alone, to say nothing of salt and fresh water algae, mosses, liverworts, ferns, lichens, and fungi. The State has an even more prodigious Fauna, there being something like 25,000 to 50,000 species of insects, spiders, reptiles, frogs, and birds. From such a colossal aggregate of species it becomes readily apparent that we need local or regional "floras" and "faunas" by which naturalists can readily and with certainty identify species of particular interest. It is to be lamented that herbaria and museums of Washington and New York, for instance, possess more complete specimens and records representing Florida present and past life than Florida itself.

A few years ago a specialist came to Florida locating and collecting various species of our many native leguminous plants in the hope of finding one rich in crotonin, a principle very powerful as an insecticide. No doubt not all is known about the other organic compounds or therapeutic properties of native plants in the State.

We need to know more about plant and animal distribution. Small's 1933 *Manual of the Southeastern United States*, to cite two examples, records dogtooth violet, *Erythronium Americanum*, and skunk cabbage, *Arisiaema foetida* for Florida. Who has seen them? Florida has a number of what might be called floristic islands. These islands harbor a strange ensemble of local, endemic, and disjunctive species of plants. At the Apalachicola River bluffs, for example, the endemic *Torreya* hobnobs with the northern leatherwood and at the same time and place with southern palms. There are accounts listing the species and offering speculative explanations. But what we really need are biological, geological, physical, and chemical quantitative data about the environmental factors of this and other floristic islands in the State. Somewhere in the State and certainly among the lower plants unknown species await discovery. And species already familiar will still surprise the explorer by looming up in new localities and situations. Painstaking scrutiny close to the substratum is sure to result in new facts and revelations.

EVOLUTIONARY STUDIES

Geologically speaking, peninsular Florida is not nearly so old as the Piedmont. Indeed the extreme southern Peninsula dates from Pleistocene times, a matter of only 10,000 to 25,000 years ago. According to entomologists, therefore, the comparatively young physiographic and geological peninsular Florida is characterized by little races of insects, groups which as yet have not reached a species rank or status. Due to present and ancient barriers and isolation, many endemic species are also to be found here. For these reasons then insects of southern Florida offer admirable material and facts for evolutionary studies.

ECOLOGICAL RESEARCH

Plant succession is one of the most important ecological concepts; and yet, when one reviews the literature or the texts, he gains the impression that this process operates only in the North and West. Florida is in sad need of detailed successional studies. Very little is known about the aggregate of species that make up our many types of climax forests. In Europe and the North, plant ecologists or plant sociologists are making statistical and quantitative studies of plant communities. Such objective studies will enable ecologists to observe trends or development in plant communities that take place over a period of years. This modern objective method of describing plant associations also presents ecologists of other regions with a much more accurate and comparable picture than the rather outmoded subjective descriptions.

We know very little about fresh water algae in relation to their environment. We do not even have a treatise of the species to be found in Florida. And this, despite the fact that these lower plants constitute the primary food supply of most aquatic plants and animals (fresh water fish and game, if you please).

Ecological knowledge applicable in the North falls short in the extreme Southeast. Most data pertaining to life conditions of ponds and lakes have been collected from bodies of water which freeze annually. Florida's warm growing season is much longer, its cold season shorter and less extreme, and its waters never freeze; the bodies of water are nearly all shallower; light rays are more nearly vertical. The sum total of all these peculiarities causes different light, temperature, carbon dioxide, and oxygen conditions. It will be readily apparent that local studies are needed to determine how our aquatic flora and fauna react to such regionally different environmental factors.

Our days are never as long nor as short as in northern latitudes. Length of day governs reproduction in many plants; there is, I

believe, even evidence that reproduction in some animals is also influenced thereby. Here is an open field for work. In the North many mosses and liverworts go through their reproductive period in the spring and early summer. In the extreme Southeast, reproduction on the part of these same plants begins in autumn and continues through the winter and early spring. For the Bryophytes, summer seems to be the period of quiescence. These at least are the indications; but we have no scientific or orderly records. The evidence points to the fact that many fresh water algae from a reproductive point of view are also most active during the cool autumn and winter months. However, here too, there is a paucity of systematized data.

WILD LIFE BALANCES

Ignorance and commercialism are gradually but inevitably exterminating our reptile life. If that is wise, I have no objection. However, as yet I question the wisdom. It is doubtful whether we shall in the near future be able to offset or cancel such philosophy, "I kill all snakes on general principles," or "I kill all snakes because I hate them." Only research and a subsequent dissemination of thorough knowledge of the life histories and interrelation of reptiles with other wild life can offer hope. Alligators are vanishing at a rapid rate. Who knows whether they should go the way of the bison and the heath hen? It is said that they destroy the eggs of the turtle that feeds on eggs of bass. Right here arises a number of questions: Does the alligator really feed extensively on eggs of turtles? Does the turtle actually destroy too many fish eggs? Does the alligator also feed on them? Does he prey upon fish? Can the alligator really catch a healthy fish? Which species, alligator or turtle is the worst offender? And so on. More research should enable us to make a more intelligent decision or campaign regarding the status of the alligator and other reptiles.

A mammalogist says that we have only a limited knowledge of the food habits of our most common native mammals. According to him apparently little is known about the diseases of our wild animals and their relationship to domestic stock and man. Neither is there a life history study of any Florida mammal that might be considered complete. When it comes to the more recent fields of science, such as Ecology, we find many blank pages or gaps; to fill them with dependable information requires years, not weeks or months.

Modern naturalists interested in research pertaining to conservation no longer take a benign "let nature alone" attitude. Specialists trained in Ecology are studying natural balances and taking steps to manipulate factors that swing the balance between wild organisms one way or the other according to particular objectives sought. It must

be perfectly patent that the more contributions there are pertaining to delicately adjusted interrelations and balances among competitive species the more successful will be wild life management.

NATURAL RESOURCES

It is essential that the potential natural resources of Florida, geological, botanical, and zoological, be investigated. Not only do we need a knowledge of our total potential resources but we also need to know how far we dare or dare not to go with the modification, utilization, and exploitation of these resources. Here I would also include some of the resources of anthropological or even esthetic interest. If some or a part of these resources must be sacrificed at the altar of progress, then the least we can do is to create accurate pictures and records of what has been. Some of our native animals and plants together with their natural setting are at least leaning, if not actually going, toward annihilation; Indian mounds are going likewise; even natural wonders like sinkholes with their concomitant, peculiar life are choked with fenders, cans, and stoves of yesteryear. We should study, record, and map what still remains in primeval state.

Florida ought not to leave its fate in the laps of geologists, zoologists, botanists, naturalists, foresters, or engineers, no matter how great their wisdom concerning the flora, fauna, or geology of other regions or lands, unless the experts in question have been on the ground long enough to be thoroughly familiar with all the aspects of the problem or problems. Major modifications of Florida land or water involving wild fauna and flora should not be permitted without the sanctions and counsel of thoroughly trained scientists fortified with years of local study.

Fundamental research of Florida clays is needed in order to determine more fully their merits in the manufacture of high grade ceramic ware. At present we really do not know whether Florida clay is inferior, equal, or superior to English kaolins which are still imported because of their alleged superiority. Moreover, basic investigation would greatly aid in finding new non-ceramic outlets for our white clays; for example, cosmetics, fillers, cleaners, and so on.

Diatomaceous earth is another raw material offering problems awaiting solution. This earth representing really the hulls of ancient diatoms is of a high quality. It can be used for polishing and dessicating purposes. The latest salt shakers are equipped with diatomaceous tops to keep the salt within dry and "pourable." Exploratory work will probably find more efficient means of mining this product and developing new uses and markets for it.

Still another example: at present, California and other states are

modifying bentonitic clays chemically and producing an earth that competes with Florida's fuller's earth as a refining medium of crude oils. Florida should be explored for possible bentonitic deposits with the view of creating a new industry. Also, the adaptability of Florida's fuller's earth toward new uses should be considered.

SOIL RESEARCH

Florida needs basic research on soils. There is much to be learned about factors that make for good soils for citrus, truck, or field crops. Yes, many of us would like to know more about soils in order to produce bigger and better roses, dahlias, azalias. We should also like to know how to avoid the periodic failures that every flower grower encounters in certain years. By the recent delicate and precise spectrographic methods trace elements not detectible by ordinary chemical methods can be determined quantitatively when as little as one part in a million is present. Members of the Academy* have detected the presence of at least seventeen elements not included in Hopkins' famous "CaFe." Just how these elements and others still to be discovered function in plant growth is still unknown. Naturally enough, the whole consideration of elements expands into mineral-nutritional problems of animals and humans. Maybe juvenile spinach mutineers are several laps ahead of us when they question the nutritional value or the presence of iron in spinach. The same species or subspecies of grasses found in Texas and Florida have a different mineral content.

In the realm of elements lies a multitude of problems for plant and human physiologists, biochemists, nutritional experts of plants, animals, and man.

Very few institutions and no scientist can afford the luxury of spectrographic instruments and accessories. Still, would not some of us ecologists like to have this beautiful technique applied to vexing problems of plant or animal distribution!

PLANT DISEASES

Much work needs to be done in the field of plant pathology. A good many organisms that cause disease of cultivated plants spend part of their life on native wild host plants. In the North, the American barberry, for example, is a wild host species that harbors wheat rust over winter. Eradication of this wild host has helped to control wheat rust. In Florida, leaf mosaic of peppers, to cite merely one example, is a disease causing great economic loss. To date, the alternate host

* Gaddum, L. W., and Rogers, L. H., *A Study of Some Trace Elements in Fertilizer Materials*, Bul. 290 Univ. of Fla., Agri. Exp. Station, 1936.

species, if there is one, of the filterable virus that causes mosaic of pepper has not been discovered. Before many of our plant diseases can be finally understood and controlled, the native alternate host plants must be found and the conditions under which they thrive or fail in nature be fully investigated.

HEALTH RESEARCH

The medical profession informs me that even from the standpoint of human health, local research is essential. Certain diseases and their symptoms vary considerably according to climate. For example, the joint symptoms of acute rheumatic fever are much milder and frequently absent in the South. Damage to the heart valves may therefore often occur with little or no preceding evidence of this disease. In this connection, it is to be noted that there is relatively little rheumatic fever in the South. Yet there is considerable in Miami. The following question arises: Why rheumatism in sunny Miami when sunshine is supposed to be a curative agent? Has rheumatism been conveyed down there from New England where it is more common? Is rheumatic fever mildly infectious?

Again, the fact that plant species and varieties vary according to geographical regions makes pollen sensitization problems essentially individual and sectional.

What might be called a multiple way correlative problem is suggested by one physician who points out that a thorough study and survey is needed in order to determine the relations, if any, between endogenous asthma, climatic conditions, native pollen producing plants and even yeasts and fungi.

Biochemists and physiologists use the term basal metabolism to designate the rate of energy metabolism or low heat production of the body when at complete rest. It is determined by measuring the amount of carbon dioxide he produces in the same interval of time. The rate of basal metabolism like and along with other physiological tests as X-rays, blood counts, and various other analyses is furnishing valuable information in diagnostic work. The basal metabolic rate for young people of the South is below the accepted normal standards.* Tables of basal metabolism prepared in the other sections and from subjects elsewhere are therefore not wholly applicable to our climate and region. Why does this variation exist? Climate may be responsible. In any event it is plain that local standards taking into account geographic variation should be worked out.

* Cason, T. Z., *The Progress of Medical Research in the South*, American College of Physicians, New Orleans, La., 1928.

CORRELATIVE STUDIES OF HEALTH CONDITIONS

In 1933, a physician* and a geologist, utilizing malaria mortality statistics and existing geological knowledge showed that there is a marked correlation between malarial incidence or mortality and Tertiary limestone sinkhole topography of Alabama, Florida, Georgia, and the Carolinas. It also appears that there is a correlation between types of sinks or basins and reaction of the water. Basins with accumulating vegetative matter are acid and favorite habitats of *Anopheles crucians*, whereas bodies of water influenced by limestone are alkaline and inhabited by *Anopheles quadrimaculatus*. However, it is not known whether or not more extensive work would all be confirmatory. A quantitative study of the chemical, physical, and biological properties favorable to malarial mosquitoes would be a contribution.

Fluorine attacks the enamel of the teeth, especially of children, and causes an unsightly mottling as well as eventual decay. A chemist† has found and determined quantitatively this element in certain Florida waters. Moreover, this chemist and a geologist working cooperatively, have found that there is correlation between certain geological strata and fluorine content of well water, furnished by such formations. Research is needed and going forward with the anticipation that water supplies may be tapped with a full knowledge of what to expect in reference to this particular and deleterious element. At present, no nullifying remedy is known. The overwhelming necessity of studying means of counter-attacking the ravages of fluorine containing waters must be obvious.

The indications are that magnesium and calcium content favor *renal calculus*. If that is so, here is a need of correlating medicine, chemistry, and geology. The latter field is to help in ascertaining what geological formations carry magnesium and calcium in such proportions as to favor *renal calculus*.

SCIENTIFIC TEAM WORK

In 1899, John M. Coulter published *Plants*. This was a book consisting of 348 pages. It covered the general field, including plant ecology, fairly well. In 1936, thirty-seven years later, there appeared a general botany text by Hill, Overholts and Popp of 672 pages. In this book, scant if any, treatment is accorded such branches as physiology, pathology, and ecology. By the present time, these babes of 1900 have waxed so lusty that we now must consult special texts for information regarding them. Early in Coulter's era, there was no

* Boyd, M. F., and Ponton, G., *The Recent Distribution of Malaria in The South-eastern United States*, Am. Journ. Trop. Med. 13: 2. 1933.

† Black, A. P., Stearns, J. H., McClane, J. H., McClane, T. K., *Fluorine in Florida Waters*, Fla. Section Am. Waterwork Assoc., 1935.

plant physiology text, nor one on ecology. Cowles' general *Ecology* of 479 pages did not appear until 1910; only six pages were devoted to Succession. By 1916 there appeared Clement's 512-page *Succession*, a text larger than Cowles' general works covering the whole subject of ecology.

Even the venerable science of Physics has sprouted tremendously new and lush growth since those calm "all is finished" days of 1895 just before Röntgen did his signal work with X-rays. In 1908, Millikan and Mills published a fairly comprehensive textbook of 389 pages on *Electricity, Sound and Light*. Today we have Compton and Allison's 828 page *X-rays* of 1935, Morecroft's 1084 page *Principles of Radio Communication*, and Wood's 519 page text on *Sound*. My, what a cathedral that simple orderly house of 1890 has become!

Anthropology says that the human brain has not increased its activity or capacity for mental pursuits in the last 20,000 years. No man may therefore hope to master any of the basic sciences; and in certain cases not even a narrow strip within the specialty. Physical scientists or biologists may and do scratch or poke around the shore or bank but between these two broad and many braided streams of the physical and biological sciences lie forgotten and unexplored islands, where mathematicians, geologists, physiologists, physicians, physicists, botanists, chemists, zoologists, and psychologists and the specialists within these fields must meet to solve basic two, three, or even multiple-way and interlocking problems.

In connection with certain pine forest studies foresters have almost reached an impasse. A study of burned plots has shown that burning concentrates such elements as calcium and potassium in the surface layer. Concentrating these minerals in the surface soils seems to be an advantage. But on the other hand, it is not known how such burning affects important organisms and life processes in the soil. Here is where the soil biologists, familiar with local soils, should step in and help to crowd back farther the unknown.

Other scientific teams active in Florida may be mentioned. We have, for instance, teams of physicians, and geologists; or chemists, dentists, and geologists. Their work has already been indicated. Another hook-up consists of a scientific utility man in this instance functioning as a botanist and, aided by a physicist, determining trace elements in plants and soils by spectrographic methods. Then we have a physicist and a geneticist determining the effect of X-rays on germination of corn and its subsequent development.

I am sure that just about now mathematicians, if there are any present, must feel like unnecessary orphans. Let them not become dependent; some pure mathematicians will be needed soon to help some plant ecologist to comprehend Bickford's *Simple Accurate*

*Method of Computing Basal Area of Forest Stands.** The term "basal area" has reference to the cross-sectional areas of tree trunks. A glimpse at the chart will show the extreme simplicity which only a dull biologist can fail to understand.

CONCLUSION

Corporations, like Bell Telephone, Dupont, Eastman Kodak, Ford Motor Company, General Electric, General Motors, and the United States Steel Corporation, have on their scientific staffs certain men who are permitted to investigate within reason any problem or any phase of a problem that they wish to. Nothing is said or asked about the immediate application of such scientific data or discoveries. Their superiors feel that any basic information will some day be useful in some way.

In support of the foregoing, I give the substance of a paragraph from a communication of Dr. Hawkins, Executive Engineer of General Electric Company. He states that although a study of oil films on water contributed to the flotation process in mining, opened up a new branch of chemistry and earned a Nobel prize, this oil film study brought nothing of direct consequence or utility to the General Electric Company. "However," he concludes, "we are not worried." So these men investigate fundamentals in a field out of sheer scientific curiosity. To the speaker it appears that institutions of learning in the State might encourage similar attacks on problems of a fundamental nature. A reasonable amount of work devoted to such problems would help to make more effective teachers and at the same time to blaze the trail for and be of assistance to the practical scientist who is expected to show results that can be measured in dollars. Problems of the type I have surveyed, have been made by scholars from other parts of the United States; visiting geologists, anthropologists, zoologists, botanists, ornithologists, and naturalists, have come, made discoveries, and incidentally taken away forever many valuable specimens and deposited them in museums far removed from here. There is nothing unethical in our accepting and using the contributions of outsiders. It is, however, to be regretted that we have not in turn been able to produce a more nearly commensurate amount of native research. Not only is it desirable, but from an ethical point of view, imperative that Florida reciprocate on a large scale in advancing the productive front of scientific investigation. Men concerned with fundamental scientific researches and those interested in industry and natural resources expect the institutions of learning of the State to participate, yes, even to lead in creative scholarship.

* Bickford, C. A., *A Simple Accurate Method of Computing Basal Area of Forest Stands*, Journal of Agriculture Research, 1935.

THE NATURE OF SCIENTIFIC PAPERS

RAYMOND F. BELLAMY

Florida State College for Women

SCIENTIFIC PAPERS generally fall into two classes. It is relatively safe to predict that the papers which will be presented throughout the coming years at this newly organized Florida Academy of Sciences will conform to this familiar pattern. The first class will consist of short specific papers on particular points or bits of new information. These will be of little or no interest to any one except those who present them and it often will be difficult to think of any particular value which they might have.

The second class will be composed of papers which will be longer, more argumentative in nature, and concerned with more or less fundamental theories. When a scientist writes such a paper for publication or to be read before some group, in all probability he will follow a prescribed formula. He will start with an apology and then proceed to show up some topic in a new light or at least from a new angle. In the course of the discussion, occasion will arise for pointing out how other treatments of the subject have been scholarly and valuable, of course, but, after all, fragmentary and partial, and lacking the clear insight which the paper under discussion shows. In fact, very much scientific material consists in showing how very wrong the other fellow is.

To the undergraduate student and to the man on the street this is often confusing. Yes, it is frequently painful. The world at large is looking to science today, hoping almost prayerfully for information and assistance. When the behavior of the scientist, as described above, is noted, it causes bewilderment. It gives the impression that there is nothing fixed or definite in science. The younger students almost universally become uncertain of their own thoughts, frequently even of their own sanity, and experience a stage of misery. The man on the street, and the one who reads his newspapers becomes a skeptic or a scoffer.

The matter is made all the worse by the fact that those who are old at the game apparently like this very situation. They spend many hours wrangling over some such minute point as to whether tweedle-dum is more or less in evidence than tweedledee. Give a teacher or a scientist an opportunity to speak or write and he will at once proceed to show how somebody, or perhaps everybody, else is entirely wrong about some hitherto commonly accepted point. However if this seemingly cocksure writer or speaker is asked to prophesy the future of his theory he is apt to say with great composure that in a few years it will be dead—entirely dead and buried. The attitude of the average

scientist may be summed up as follows:—"On this point everybody else is terribly wrong; here for the first time is complete truth; in a few years it also will be wrong."

Since teachers and scholars (perhaps mutually exclusive terms) are just naturally constituted this way, there is apparently nothing which we can do about it. But it may not be an altogether unforgivable sin if we depart from the usual routine, for at least this one time, and attempt to show how some of these folks may possibly be right; if, instead of showing how different they are, we attempt to show some points of agreement. When we do this, we find that very often the differences are quite insignificant. There is a large body of material about which there is agreement—not approximate agreement, but complete agreement. There is a vast body of material which has been tested, tortured, discussed, modified, and accepted—and then promptly forgotten. We do not think of these commonly accepted facts any more than we remember that there is a law against cannibalism.

We see this everywhere. Not long ago I happened to speak to a physician about the work being done on the ductless glands. He answered me at once, "Oh, we really do not know anything at all about them." I could not help thinking of the way thyroxin is used to cure that dreadful form of idiocy called cretinism; of how so many thousands are alive and relatively well today who would have been dead long ago except for insulin; of how adrenalin applied locally will prevent bleeding, or used in other ways become a powerful stimulant and will even bring to life a dead heart; of the way other glandular products are used in childbirth, to control disordered growth, to prevent excessive menstruation, and even to do such everyday things as to prevent baldness. All these practices are commonly known by even us laymen. The doctor to whom I was talking proceeded to tell me a dozen or so more abstruse discoveries centering around these glands. But he insisted that we really know nothing about them. What is really known, we forget that we know.

Instead of keeping our eyes on our established body of knowledge, we quarrel and theorize over minute points which are usually quite insignificant. Furthermore, even those bitter, deadly, unforgiving quarrels between the "true" scientists on the one hand, and those whom they call the "pseudo" scientists (psychologists, sociologists, etc.) on the other hand are usually over terribly important points which do not exist.

A case in point is the quarrel between certain psychologists and equally certain physicists over the relation of the different colors to each other. But the Helmholtz theory which so many physicists

stubbornly retain rests on the mixing of pigments. The Hering theory, on the other hand, seeks to explain what happens in the retina of the eye. The two are not at all hopelessly antagonistic.

This, then, is the first point to keep in mind, namely that there is a vast field of information upon which there is general agreement. To be sure, some of our commonly accepted theories are later proven to be fallacious. This is true in all experiences of life. But the occasions on which it is a fundamental destruction of the old theories are very rare. Nearly always it is a mere modification or an elaboration of the old theory which has occurred. To illustrate this we may take the case of Darwin. During the last few years it has become a popular indoor sport to show how Darwin was wrong. Scholars, investigators, teachers, and beginning students all alike assume a knowing and somewhat condescending air and say, "Oh, of course, nobody holds to Darwin's theory nowadays." Quite true. Yet the fundamentals of Darwin's theory are more firmly established, more undisputed, and more highly respected today than ever before. It is only the details which have changed.

That which is true of Darwin's theory is also true of many others. Even such theories as those of Mendel, Weismann, and DeVries are at most only somewhat dented and are not at all pulverized by the powerful blows of Jennings and other contemporary geneticists. In fact, there is much which has come down to us substantially unchanged from the days of antiquity. At Dr. William H. Burnham's seminar I once heard a student give a review of a very popular new book on educational theory. But Dr. Burnham remarked that with the exception of the expression "conditioned reflex" there was nothing in it which had not been said by Comenius. And Comenius had described even the conditioned reflex under another name. Turning to Plato and Aristotle, it is nothing short of amazing to see how accurately and clearly they stated quite modern theories and principles. Thus it appears that in contrast with the pessimistic views of the beginning student and the man on the street, there is a vast field of scientific information and belief which has remained substantially unchanged not only for years and generations but for centuries. We forget what the old scholars said and say it over—sometimes better and sometimes not so well, but always in somewhat different terms.

Perhaps it is saying about the same thing when we call attention to the fact that much of the quarreling and disagreement between scholars is in fact a quarrel over terms and definitions. Usually this is not realized by those who are furnishing the entertainment since each has so vividly in mind the specific point which he is trying to

establish that he can see nothing else. In actuality the seemingly most remote theories are often all but identical.

This can be illustrated in any field. In sociology let us glance at the concept of Social Forces. Ward said they were the emotions, Small makes them the six interests, Thomas conceives of them as four wishes, Ross says they are instincts and interests, the educational sociologists conceive of them as the institutions, and numerous other writers have apparently attempted to conceal their true theories by their involved and ambiguous terms. But we can boldly and unhesitatingly say that an analysis shows that they are all trying to say the same thing. They are all in substantial agreement, even including Hayes who says that there are no social forces. All that Hayes means is that the emotional reactions are experienced by individuals and not by any abstraction of a group, and every one of our writers knows that.

As expressed by Ole Reliable, the Mississippi darkey, when he described the natives of southern Egypt, "They ain't a dime's worth o' difference twixt these niggers and the ones back home."

In psychology the same is true. Even the remarkable lengths to which modern psychologists go can be shown to lack some of the terrifying connotations which they seem to have. Perhaps Sigmund Freud is considered about as extreme as any. The Freudian theory is generally looked upon as something of a cross between a case of delirium tremens and hog cholera. But Freud is not so bad. As Mark Twain said about Wagner's music, he is not so bad as he sounds. The modern psychologists have concluded that Freud was completely and absolutely wrong, but have accepted substantially everything which he ever said, only under a bit different set of names. I am told that Knight Dunlap of Johns Hopkins would probably die of apoplexy if he should be told that he agrees with Freud. Yet I make bold to state that fundamentally even he says the same thing. Of course, Freud has suffered greatly from mistranslation, and this is the most confusing factor in the case.

Another somewhat spectacular quarrel that is raging at present is concerned with the use of statistics, especially in educational measurements. To listen to some of these quarrels we are reminded of the story about giants sitting on grave stones cracking peanuts with sledge hammers. One enthusiast will insist on the value of statistical tests of ability, intelligence, achievement, or whatever we may be trying to measure. A second will speak up and exclaim that such tests are wholly unreliable as far as proving anything about the individual is concerned. (There are some of us who knew this all the time.) If our loud disputants could just for a moment try to get together instead of trying to demolish each other, they would quickly agree

that such tests are valuable as a rough practical means of selection and are probably superior to any other means which we could use.

The biologists have their copious quarrels over exact terminology and infinitely minute points of difference also. We have already mentioned their fights over questions of heredity. But the stock raisers, horticulturists, farmers, and fanciers keep right on securing splendid results in the applications of the principles which have been given them, regardless of all these wordy quarrels. As it is with heredity, so it is with almost every biological question. The methods of evolution, of selection, of adaptation, of species differentiation, and numerous other points are all substantially agreed upon by our biological friends. But they would not acknowledge it for worlds.

The controversies in chemistry and physics are equally evident, especially within the sanctum of their own group. The wave of what might be called scientific hysteria that has swept over this country since Einstein began making his utterances shows this. The work that is being done on the structure of the molecule and the atom and the corresponding behavior of the electrons adds much scientifically inflammable fuel to the hysterical fire. Ask such a scientist a leading question today and he is sure to begin his answer by saying that all the old fields of scientific belief and all the old axioms and fundamental postulates are completely destroyed and the entire foundations of his science are demolished. Yet all this has not affected the building of bridges and cathedrals nor the construction of engines and rifles in the least. But it has provided a splendid field for endless discussion and disputation.

I understand that we are now called upon to give up the old belief in the existence of the luminiferous ether. We had formerly thought of it as a scientific abstraction, filling all space and existing only as a concept to furnish a basis of explanation for various natural phenomena. But now we are told that it does not exist at all and that light, etc. travel by some other medium which is likewise just an abstraction and which we must think of as existing only as a concept which fills all space. We are reminded at this point of the researches carried out by our friends the classical scholars. They finally concluded that the *Odyssey* and the *Iliad* were not written by Homer but by another man of the same name.

In every field, the situation is the same. There are endless quarrels about the different ways in which the same thing should be said. It is true, of course, that we can not explain away all the differences between the theories and beliefs of the various writers. There are some differences which are quite real and very great. But such genuine fundamental differences are not found as often as is generally supposed.

Shall we say then that these quarrels, discussions, controversies, arguments, and differences of opinion are destructive and worthless? Shall we conclude that scientific investigation of such minute points is a waste of time? Not at all. In spite of all that we have said, there is no question but that they are exceedingly and immeasurably valuable. We must remember that the scientist is not interested in talking about the established facts and principles. His interest is in the field which is not yet established. We would get nowhere if we spent our time discussing established facts. We may say that the scientist who does not reach out and attack those questions about which there is still no agreement is like Lot's wife—destined inevitably to turn to lifeless, inanimate matter. In other words, he soon petrifies. There is no other way beside that of painstaking study and endless experiment by which we may attain progress. In no other way can the beginning student or the veteran secure stimulation. To be sure it gives the superficial impression of a great boggy, miry, unstable field. But in reality we are looking only on the foremost outposts of the advancing line. The next generation will have passed on to new positions and we shall have established a bit here and there, be they ever so small.

This is well put by Lester F. Ward, the pioneer American sociologist. "The progress of science is no even straight-forward march. It is in the highest degree irregular and fitful. . . . Whatever the field may be, the general method of all earnest scientific research is the same. Every investigator chooses some special line and pushes his researches forward along that line as far as his facilities and his power will permit. . . . He observes and experiments and records the results. . . . If the results are at all novel or startling, others working along similar lines immediately take them up, criticize them and make every effort to disprove them. . . . Part of them will probably stand the fire and after repeated verification be admitted by all. These represent the permanent advance made in that particular science. . . . Nothing is established until it has passed through this ordeal of general criticism and repeated verification from the most adverse points of view."

We may compare this advance of science to the flow of a river. Standing on the bank, we may notice twigs and leaves floating upstream, eddying round and round, moving transversely, or being washed up on the shore and left. But always and all the time the main current of the stream is flowing steadily in one direction. Little dribblets—little insignificant definitions or infinitesimal points of discovery or interpretation constitute the scientist's stock in trade. Over these pitifully little bits do we quarrel and contend and learnedly and profoundly come to conclusions or disagree with those who do.

But tiny particles of dust eventually buried the cities of Chaldea and Babylon and minute bits of silt at last built the delta of the Mississippi. Were it not for our attention to these bits of theory and discovery and if they were not beaten out in the heat of controversy, stagnation is the only thing which could happen to us.

Small fear is there of that! Scientists just will be scientists. We may confidently expect to continue to hear the same old fashioned type of scientific papers. And thereby the world will advance.

THE FREEZE OF 1934

GRAY SINGLETON

Horticulturist, Federal Land Bank, Columbia, S. C.

ON DECEMBER 12 and 13, 1934, Florida experienced the most severe damage from cold since the winter of 1894-1895. Comparison of weather bureau records shows that the temperature did not go as low in 1934 as in either the freeze of December 27, 28 and 29, 1894, or the freeze of February 7, 8 and 9, 1895. The following table gives comparative data. The reporting stations are arranged in the order of their latitude from north to south.

MINIMUM TEMPERATURES (FAHRENHEIT) RECORDED DURING THE FREEZES OF 1886, 1894-95 AND 1934

Place	Latitude	Jan. 12, 1886	Dec. 29, 1894	Feb. 8, 1895	Dec. 12, 1934	Dec. 13, 1934
Jacksonville	30 19½	15	14	14	23	33
St. Augustine	29 53½	17	16	16	23	28
Federal Point	29 45	—	17	16	26	20
DeLand	29 00¼	17	16	17	23	20
Eustis	28 51½	18	16	16	24	—
Sanford	28 48	21	18	18	25	—
Titusville	28 36	—	18	19	23	26
Orlando	28 32½	19 & 20	18	19	22	24
Merritts Isl.	28 22½	—	22	22	27	32
Melbourne	28 05½	—	22	—	—	—
Tampa	27 57	—	19	22	27	34
Avon Park	27 36½	—	21	23	26	21
Manatee	27 30	—	19	23	28	25
Jupiter	26 56¼	—	24	27	—	—
West Palm Beach	26 43	32	25	29	31	—
Myers	26 39	—	24	30	29	33
Hypoluxo	26 35½	—	26	32	31	34
Key West	24 38½	41-43	44	49	45	48

We are indebted to Dr. Herbert J. Webber, of the United States Department of Agriculture, for an excellent account of conditions during and following the two freezes of 1894-1895. The first three columns of the preceding table were prepared by Dr. Webber. The last two were furnished the writer by the Weather Bureau. Dr. Webber's report was written November 1, 1895, and by making reference to it we get an interesting and comparative picture of conditions as they existed then and after the freeze of 1934. In Dr. Webber's report we find this statement:

The injuries to the fruit industries were very great, orange, lemon and many tropical trees being generally killed to the ground in all parts of the State except in the extreme southern portion and on the keys. Certain well protected localities in the central part of the peninsula also escaped without serious damage, but on the whole, latitude was the only modifying influence of any importance. As the blizzards swept southward their severity gradually decreased. Judging from reliable temperature records and from the effects of the cold on vegetation, the isothermal lines in both freezes ran almost directly east and west across the State.

Dr. Webber refers to his table showing temperatures at various latitudes as follows:

From a comparison of the locations given in the preceding table it will be seen that in any given latitude practically the same temperature prevailed in localities whether in the western part of the State, in the interior, or on the east coast. The Manatee region, protected on the north by the broad Manatee River and Tampa Bay, shows almost the same temperature as Avon Park, in about the same latitude, in the interior, and Melbourne on the east coast. Again, Myers, on the west coast protected on the north by the broad Caloosahatchee River, and West Palm Beach, on the east coast, protected on the west by the waters of the Everglades, show nearly the same temperature.

This was not the condition which existed during the freeze of 1934, as may be seen by reference to the temperature records, particularly on the morning of December 13, when the temperature was 33 at Jacksonville and 26 at Homestead. Using stations of near the same latitude we find Bradenton, on the west coast, with 25 degrees; Avon Park, in the interior, with 21; and Ft. Pierce, on the east coast, with 33 degrees. We also find Ft. Myers, on the west coast with 33 degrees; Moore Haven, in the interior, with 24, and Hypoluxo, on the east coast with 34. Going farther north and using points not greatly differing in latitude we find St. Petersburg, on the west coast with 40 degrees; Tampa, on Tampa Bay with 34; Plant City, in the interior with 22, and Merritts Island, on the east coast, with 32.

On the morning of December 12, 1934, the temperatures corresponded more closely with the latitude but we still find the interior points colder, as a rule, than stations on the east or west coast. On

moved down into Hardee, DeSoto, Highlands and Glades Counties, and the temperature had risen in the counties to the north. The center of the cold wave seems to have passed to the south and west of Miami, since the temperature on the morning of the thirteenth was 7 degrees lower at Homestead than at Miami, and mangrove was killed along the Tamiami Trail to within about ten miles of Miami.

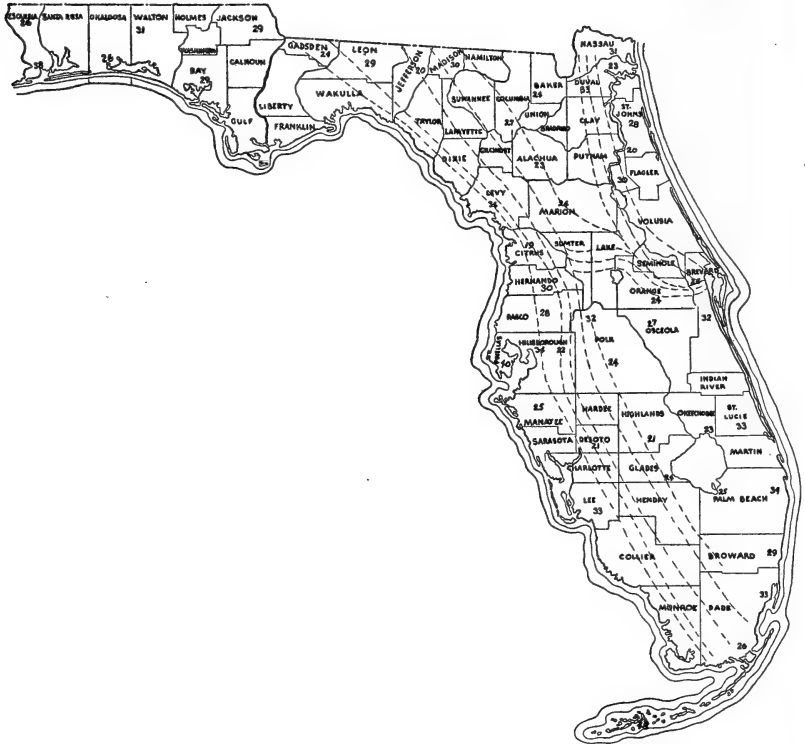

FIG. 2. Temperatures (F.) morning of December 13, 1934. Dotted lines show air flow as indicated by damage to vegetation.

The writer made trips over Florida following the minor freezes of 1917 and 1927. In each of these years the damage to vegetation was most severe in the same areas where serious freezing occurred in 1934. For instance, in Hillsborough County the area extending north and south through Valrico and Thonotosassa was seriously damaged while groves in comparable topographical locations at Lutz, in the same county, were not hurt. In fact after each of these freezes the damage to vegetation indicated that a river of cold air flowed down the west-central part of the State and followed practically the same

course each time. In general this stream of cold air seemed to follow what is known as the flat woods area, but this was not always the case. At Valrico a row of eucalyptus trees, along the Hopewell-Tampa road on top of a considerable hill, showed a distinct freezing line which extended some twenty feet above the top of the hill. Below this level they showed marked damage while above it they were unhurt. Similar areas are located a few miles northwest of Leesburg and northwest of Orlando. The Peace River Valley from Bartow south, seems to have furnished a channel for the flow of cold air. In these areas the flow of cold air could be definitely followed by the damage to vegetation after each of the three freezes. There were also indications that the major stream of cold air split in Marion County, probably where part of the cold wave crossed the ridge through the Ocklawaha River Valley. One branch of this stream flowed south over Citrus, Hernando and Pasco Counties, while the other followed the west side of the St. Johns River, flowing into Volusia County, across the western side of Seminole County, across parts of Orange County and into Osceola County. In other words, it appears from a study of the damage to vegetation, that the hills and lakes of the ridge section, starting in northern Lake County around Eustis, form a wedge which tends to split the cold wave. This ridge section, from Eustis to Lake Placid, showed only minor damage in low spots following each of the three freezes mentioned, while serious damage occurred on both sides of the ridge. Apparently the damage was caused by a great mass of cold air moving into Florida from the northwest. The greater portion of this mass of cold air seemed to flow to the western side of the ridge without crossing. This may account for the absence of damage in the area from Cocoa to Ft. Lauderdale. Should a cold wave move into Florida from the northeast the west coast might get similar protection from the ridge.

From a study of Dr. Webber's report of the two freezes of 1894-1895 it appears that the cold wave, in both instances, moved into the State from the north rather than from the northwest. This would account for his statement that the isothermal lines were practically east and west throughout the State.

A study of temperature records and damage to vegetation following the freeze of 1934 indicates that the ridge section along the east side of the St. Johns River gave similar protection to the upper east coast as did the central Florida ridge to the area from Cocoa to Ft. Lauderdale. It would also explain why Titusville was colder and suffered more damage than either New Smyrna or Cocoa. A map precedes which shows the probable flow of cold as indicated by temperature records and damage to vegetation.

During 1933 and 1934 the Federal Land Bank of Columbia, for

itself and as agent of the Land Bank Commissioner, loaned more than \$10,000,000 in Florida, on mortgages secured by citrus groves. In order to determine the damage to groves securing these loans and as a guide to a future lending policy, it was decided to make a careful survey of each of the 2326 groves on which loans had been made. By reference to the attached table it will be noted that these groves are located in thirty-three counties, embracing all of those in which citrus fruits are grown commercially, except the Satsuma district of West Florida. This survey was started on February 15, 1935, and was completed in about six weeks. The work was done by trained Land Bank Appraisers and Citrus Loan Service Agents all of whom were thoroughly familiar with citrus conditions in Florida. It was under the direction of the writer as Senior Citrus Loan Service Agent that the work was done. Each grove was visited and a careful estimate made of the damage to wood and fruit, by groups having similar characteristics. By groups is meant oranges, grapefruit and tangerines, since no attempt was made to determine the relative damage to different varieties of oranges. Neither was there any differentiation between seeded and seedless grapefruit or between the different varieties of tangerines. The estimate of wood damage was based on all wood except the trunk of the tree. Fruit was considered damaged where it showed ten percent or more of dry cells. The presence of specks of crystallized naringin and hesperidin was not considered evidence of damage if the fruit was firm. Soft fruit was considered damaged even though showing no dry cells, because it was found that it could not be shipped without rotting in transit. As near as possible the estimate of damaged fruit was made on the basis of what could not be marketed commercially.

With the exception of the area from Cocoa to Ft. Lauderdale, on the east coast, and protected spots on the west coast such as Terra Ceia Island, there was very little fruit in the State that did not show specks of crystallized glucosides on the membranes. These specks may be considered as evidence that the fruit has been frozen.

As each grove was inspected a detailed report was made on forms provided for the purpose. These reports were sent to district supervisors who checked enough of them to be sure that the work was properly done and they were then sent to the Bank at Columbia where statisticians tabulated the results by counties. The table (page 32) is a composite picture of what was found.

The first point noted was that, in this freeze, latitude had very little influence on the amount of damage done by the cold. At South Jacksonville, south of the St. Johns River, there were small plantings that showed little or no damage and from Palatka to Crescent City, on the east side of the same river, there were found large commercial

plantings that were practically unharmed. On the other hand, in Lee County some three hundred miles further south, all groves were seriously hurt where no large body of water was present to afford protection. Putnam County, in the northern part of the State, showed 7.9, 8.1 and 7.7 percent damage to the wood of oranges, grapefruit and tangerines, while Lee County in the south showed damage to wood of 29.9, 23.5 and 26.4 on oranges, grapefruit and tangerines; with fruit damage of 82.1, 75.3 and 85.7 respectively. It should be noted in this connection that most of the groves in Putnam County are on hills and are protected by the St. Johns River and by lakes, while groves in Lee County are on practically level land and many of them are too far from large bodies of water to receive any benefit.

In making this survey it soon became apparent that two factors had much more influence than latitude. They were large bodies of water and elevation. Elevation may be divided into two classifications—relative elevation and absolute elevation. By relative elevation is meant elevation with respect to the immediate surrounding terrain and by absolute elevation is meant height above sea level. Absolute elevation seemed to afford little protection, while the importance of relative elevation cannot be too strongly emphasized. Trees planted in a small depression on top of a hill were found to be seriously hurt while trees planted on the sides of the hill, at lower absolute elevation, were unharmed. Cold air seemed to flow like water and settle in low places. There also seems to be a concentrated effect of cold air where it flows from a large elevated area into the lowlands. This was evident in many places, particularly east of Ft. Meade where the cold air flowed off of the Lake Hendry hills, and at Mammoth Grove where the cold air poured down from the hills around Mountain Lake. Groves located near the foot of the hills were hurt much worse than those farther back in the lowlands.

Many peculiar effects of the cold were noted. In certain areas the cold air seemed to settle to a definite level. The branches of the trees below this level were all killed while those above it were unharmed, and when the dead branches were pruned out the trees were left in the shape of umbrellas, which would indicate that the damage was done after the wind stopped blowing. Another noticeable feature in many groves was the fact that more damage was sustained on the southeast side of the tree than on the other sides. This was thought by some to be due to the exposure to the direct rays of the sun before thawing.

It was clearly demonstrated in many instances that water protection is most effective to the south and east. On the Manatee River, at Bradenton, and on the Caloosahatchee River, at Ft. Myers, the mangroves were killed on the north side of the rivers while they

remained green on the south sides. At Lake Weir groves on the west and north sides of the lake were hurt while those on the south and east escaped injury. The same condition existed at most large lakes. However, those groves having good elevation and air drainage were not seriously damaged, even where there was no water protection. In most areas, except the east coast, the fruit was damaged or showed evidence of freezing where there was no water protection, even though the air drainage was good.

Following the freeze several growers abandoned properties on which loans had been made by the Federal Land Bank and three methods of bringing these groves back into production were tried.

First—pruning back into green wood as soon as the limit of injury could be determined and painting all wounds with antiseptic paint.

Second—pruning back into green wood as soon as the limit of injury could be determined but no paint applied to the wounds.

Third—Waiting for several months before doing any pruning.

The first method seemed to give the best results. Vigorous growth resulted and there was very little dying back after pruning. In cases where no paint was applied there was considerable dying back, sometimes three feet from where the first cut was made. This was accompanied by gum spots on the bark and may have been due to diplodia or other infection at the cut. These trees had to be pruned again.

The third method did not give good results. Melanose was very bad on the new growth and much of it was killed, the green limbs dying back slowly until about the first of June. There was some gumming along the branches as they died and the dying back did not stop entirely until the trees were pruned and wounds painted which was done in June and July of 1935. As this is written, November 1, 1936, the trees pruned in June and July, 1935, show much less recovery and top development than trees in the same grove and the same rows that were pruned in March of that year. These observations do not agree with the report of Dr. Webber, following the freeze of 1894-1895. He found little difference in the trees pruned early in 1895 and those pruned late in the year. Possibly melanose and diplodia were not then as prevalent in the citrus groves of Florida as they are now.

As this is written, November 1, 1936, there is very little in the appearance of most of the groves to remind one of the freeze. In a few of the coldest spots the gaunt, unpruned skeletons of abandoned groves still stand as mute evidence of the disaster. With these few exceptions the citrus industry of the State is back to normal. In fact, the crop of this season is estimated to be above the average, both as to quality and quantity. This is quite a contrast to the crop set in the

spring of 1935, following the freeze. The crop bloomed late, was of poor shape and texture, and was badly infected with melanose from dead wood left by the freeze. The recuperative capacity of the citrus tree is amazing when given proper care. Groves that seemed a total loss shortly after the freeze have, in two years, grown new tops and have this year put on commercial crops of fruit. Florida has been visited by severe cold at more or less regular intervals in the past and probably will be in the future.

In Dr. Webber's report we find the following statement:

It is known that severe freezes occurred in the winters of 1747, 1766, 1799, 1828, 1835, 1850, 1857, 1880, 1884 and 1886, and many lesser freezes are also known to have taken place. Those which were remarkably severe, however, and which are spoken of as "the great freezes" occurred on February 7 and 8, 1835, and January 12, 1886. In the former, the only one which in severity and destructiveness compares with those of last winter, the thermometer, it is said, fell to 8 d. at Jacksonville.

When freezes come the grower should not feel that his property is gone until he has given the grove a chance to come back. Unless the damage is exceedingly severe the grove will return to commercial production in a remarkably short time. However, this should not encourage the selection of a grove site in a known cold area. Most of our cold waves come from the same direction and affect the same areas and it should be borne in mind that relative altitude, air drainage and water protection have offered a measure of protection in the past and probably will in the future. Should we have a recurrence of conditions such as existed during the freezes of 1835 or 1894-1895 it is not likely that any groves in the State, with the exception of a few in well protected localities, would escape serious damage.

SUMMARY

Cold air, like water, settles in depressions and flows from areas of high altitude to areas of low altitude through such channels as may be available.

Cold waves moving into Florida from the northwest seem to flow along the western side of natural elevations, such as the Citronelle formation of Central Florida, commonly called the Ridge. This seems to give some protection to areas on top of and to the east of such elevations.

Areas of low land immediately adjacent to large areas of elevated land, suffer more severely from cold than flat areas distant from any elevation. This effect may be noted where any abrupt change in elevation takes place, either to the east or to the west, or in any other direction, from the elevated area.

FREEZE DAMAGE TO WOOD AND FRUIT ON FLORIDA CITRUS GROVES MORTGAGED TO FEDERAL LAND BANK AND/OR LAND BANK COMMISSIONER
DECEMBER 1934, AS ESTIMATED BY FLB CITRUS INSPECTORS

County	No. of Properties	Total Am't. Loaned	WOOD DAMAGE (ALL ACRES)						FRUIT DAMAGE (BEARING ACRES)					
			Oranges		Grapefruit		Tangerines		Oranges		Grapefruit		Tangerines	
			Acres	% Damage	Acres	% Damage	Acres	% Damage	Acres	% Damage	Acres	% Damage	Acres	% Damage
Alachua	6	\$20,700	94	23.2	1	5.0	12	53.0	90	71.8	3	83.3	12	98.4
Brevard	87	539,595	2234	.9	684	2.3	67	2.4	2146	10.8	609	4.8	63	19.1
Broward	5	9,600	39	3.1	2	9.0	2	5.0	34	36.3	2	0	2	80.0
Charlotte	11	31,000	124	35.0	38	33.6	23	67.5	90	60.0	27	40.6	9	100.0
Citrus	3	4,700	30	30.0	0	0	8	10.0	18	50.0	0	0	4	100.0
Dade	66	355,700	583	0	628	0	19	0	562	1.5	584	1.0	19	.8
De Soto	97	699,950	1436	58.0	302	48.7	158	72.1	1315	89.1	293	72.4	148	94.0
Flagler	1	800	3	5.0	0	0	1	0	2	0	0	0	1	0
Hardee	129	415,612	1989	57.9	217	39.5	253	51.3	1640	90.6	195	72.6	233	94.2
Hendry	4	6,370	22	40.1	4	38.0	3	61.6	17	74.0	3	50.0	1	100.0
Hernando	22	60,850	137	39.7	72	10.6	137	18.1	120	93.9	72	80.3	117	93.6
Hillbards	64	352,225	2361	5.1	743	2.9	89	18.3	1220	14.4	723	6.3	86	26.0
Hillsborough	160	618,774	2065	53.2	541	62.3	202	56.4	1758	80.1	499	78.6	194	86.8
Indian River	94	375,090	572	1.5	943	1.5	112	1.5	539	7.2	838	5.2	107	12.6
Lake	168	672,840	2436	17.3	803	14.1	370	11.0	2052	44.8	712	49.8	347	60.8
Lee	26	89,750	338	29.9	148	23.5	18	26.4	309	82.1	144	75.3	16	85.7
Manatee	62	286,600	531	38.4	557	26.7	2	18.9	447	56.6	471	41.6	2	65.7
Marion	39	170,050	737	16.6	56	5.1	71	26.9	556	28.0	53	19.6	48	76.2
Martin	8	14,750	28	1.5	23	1.7	6	0	27	2.3	23	5.2	6	0
Okeechobee	3	6,400	27	13.7	7	18.4	1	0	27	32.9	7	36.9	1	0
Orange	222	1,076,080	4176	24.2	456	22.8	580	28.4	3647	39.5	441	31.5	504	52.8
Osceola	54	144,200	622	19.0	142	11.9	1202	1.4	546	44.8	126	27.9	113	59.3
Palm Beach	1	1,000	2	0	0	0	0	0	2	0	0	0	0	0
Pasco	51	146,400	691	15.4	218	16.8	78	20.3	471	58.1	164	44.0	70	93.3
Pinellas	97	609,525	1135	19.1	1516	23.2	119	22.3	1074	48.2	1438	50.4	117	62.4
Polk	541	2,232,975	7229	18.1	3512	13.9	891	17.0	6635	49.0	3388	32.2	891	42.7
Putnam	34	115,075	465	7.9	36	8.1	65	7.7	412	19.8	36	18.8	64	44.2
Sarasota	9	35,950	106	7.3	113	50.4	1	90.0	106	79.4	113	68.8	1	100.0
Seminole	67	244,765	1110	41.5	261	62.8	99	31.9	933	68.4	254	85.9	94	84.4
St. Johns	2	2,700	2	75.0	1	60.0	30	93.0	2	0	1	100.0	28	100.0
St. Lucie	55	242,350	515	1.6	323	.2	93	.5	484	3.4	299	.7	92	2.2
Sumter	7	19,100	67	72.3	1	25.0	8	28.7	47	97.8	1	100.0	8	100.0
Volusia	131	511,035	1878	38.8	155	21.1	395	43.4	1573	67.0	144	29.2	372	90.2
STATE	2326	\$10,112,511	32,784	26.8	12,503	17.6	5,115	21.7	28,901	48.5	11,683	34.5	3,830	61.2

In the freeze of 1934 water protection and relative elevation were effective in preventing serious damage as far north as South Jacksonville and Palatka, while groves on level lowland and without water protection were badly hurt in Lee County, three hundred miles south.

Very severe damage is likely to occur where a major stream of cold air is forced to cross through the lower parts of a relatively high area, such as Valrico, where the ridge to the north and east of Tampa and the higher land of the interior form a funnel through which the cold air must pass.

Careful estimates of damage to wood and fruit were made on 2326 groves located in 33 counties. Averages of these reports have been compiled by counties and are given in the opposite table. Averages for the State as a whole give the following figures:

Damage to oranges, wood	26.8 percent
Damage to grapefruit, wood	17.6 percent
Damage to tangerines, wood	21.7 percent
Damage to oranges, fruit	48.5 percent
Damage to grapefruit, fruit	34.5 percent
Damage to tangerines, fruit	61.2 percent

Citrus groves recover very rapidly from cold damage if given the proper care.

Groves recover more quickly if pruned back into green wood as soon as the extent of damage can be determined and the pruning cuts treated with antiseptic paint.

Acknowledgment is made of assistance rendered by Mr. Eckley S. Ellison, Meteorologist in charge of the Florida Frost Warning Service, who furnished temperature records covering the two nights of the freeze.

SOME CONSEQUENCES OF PSEUDO-MATHE- MATICS AND QUASI-MEASUREMENT IN PSYCHOMETRICS, EDUCATION AND THE SOCIAL SCIENCES

CHRISTIAN PAUL HEINLEIN
Florida State College for Women

THE PRIMARY purpose of this paper is to describe briefly certain trends and widely accepted conclusions that have emerged from numerous pseudo-mathematical practices as they appear in the familiar fields of psychometry, education and social psychology. A few of the pseudo-mathematical practices which have led to many

thousand apparently useless quasi-measurements will be mentioned in the course of discussion. Scientific criteria of measurement will be indicated and their limits of applicability to certain behavioral phenomena carefully considered. Finally, substitute mathematical procedures that may lead to more accurate description of behavioral situations will be recommended.

Before a description of some of the consequences of quasi-measurement is undertaken, the writer wishes to state that he fully realizes the unpopularity which a critical evaluation of authoritative and traditional knowledge inevitably reaps. The present treatise is likely to prove extremely unpopular to a large body of educators who persistently disregard logic and the principles of scientific interpretation. The amount of pseudo-scientific knowledge that has accumulated in psychometry, education, and social science during the past twenty years is truly enormous. Many investigators in social science, fascinated by the intricate weave of nice mathematical tapestries, have constructed special numerological devices and elaborate statistical techniques which often give to syllogisms based on false premises the appearance of verified fact. It behooves the scientist, whose concern is the discovery of natural law, to evaluate critically in the light of logic and scientific method those spurious devices and specious techniques which block the road to truth and which further swell the volume of pedagogical equivocation.

Let us first consider the widely accepted practice of leveling scholastic achievement by means of number grades. I assume that each of us is familiar with the five-point system of grading student achievement. Conventionally, levels of achievement, determined by the percentile scaling of objective test results or by some subjective criterion of evaluation, are represented by letter symbols, such as *A*, *B*, *C*, *D*, and *E*. Since the letter symbols do not readily lend themselves to the process of addition, they are arbitrarily converted into numbers: $A=3$; $B=2$; $C=1$; $D=0$ and $E=0$. It will be observed that numerically $D=E$, in spite of the fact that *D* is a passing grade while *E* is a failure. Thus, qualitative differentiation is achieved by this single pair of letter symbols (*D* and *E*) but not by the numerical values assigned to the symbols. With respect to the first three letter symbols, quality differentiation is accomplished by a difference in the size of the assigned numerical value. The quality of response represented by the number 3 is higher than that represented by the number 2. In differentiating the quality levels of student achievement, by an act of pedagogical proclamation the nominal numbers assigned to the letter symbols are transmuted into cardinal numbers having additive properties. Here is our first sample of illicit mathematical treatment—a type of treatment which has deeply penetrated several important

fields of knowledge. Many of the fallacies that are found in mental testing, educational achievement testing and in social attitude scaling, have their origin in the failure to differentiate between nominal, ordinal, and cardinal numbers. Many zealous educators would benefit greatly by reading the works of Johnson,¹ Keyser,² and Cohen and Nagel³ on the nature of logic and scientific method. Following the lead of Johnson, we may remark in passing that no meaning can be attached to the result of any operation performed on nominal numbers that merely serve as naming numbers for certain discernible properties. While it is true that one may find the arithmetic mean of any column of numbers having a definite sign, it is not true that one may ascribe qualitative value to every mean obtained. Qualitatively, two objects denoted by nominal numbers may stand in a relation to each other that in no way corresponds to the relation expressed by the numbers.

Nominal number grades, whether they are derived from so-called objective tests or from comprehensive essay examinations, are non-additive and hence are of no value in correlational techniques where the variables represent defined unitary properties experimentally isolated. The fact that 10,000 educators add, average, and scale such nominal numbers does not make the procedure any the more valid or scientific. Writing $6 \times 9 = 25$ one million times does not make the product 25 correct the last time it is written. Nor does repetition of a bad measurement a million times make it a good measurement. Professional opinion and professional proclamation, like public opinion and public proclamation, may keep alive a fallacious practice over a long period of years. Some of the most colossal blunders of Aristotle were perpetuated more than fifteen centuries later by professional proclamation minus critical insight.

By professional proclamation (certainly not by scientific demonstration) the hypostatized abstraction called "intelligence" has been assigned operational significance by relating test ordinals to the averages of non-additive grade numbers. Intelligence test scores, qualitatively heterogeneous in character, are now being used by psychometricians as forecasting-indices of scholastic achievement when scholastic achievement is understood in terms of number grades denoting qualitative levels of response.

Let us look into this matter a little more carefully. A number grade of the size 1.8 in differential calculus cannot be said to equal a number

¹ H. M. Johnson, *Some Neglected Principles in Aptitude Testing*, Amer. J. Psychol., Vol. 47, 1935.

² C. J. Keyser, *Mathematical Philosophy*, New York, 1922.

³ M. R. Cohen and E. Nagel, *Introduction to Logic and Scientific Method*, New York, 1934.

grade of the same size in English literature. These two courses of study introduce properties discernibly different. Moreover, the teaching methods demanded by each course of study may vary considerably while the patterns of student response are obviously different. No one is in a position to demonstrate that the number and kind of mental patterns manifested in the two courses of study are the same, but any one who is unbiased in his judgment and who is not deficient in gross discrimination will readily attest to the differences in the properties of the subject matter involved in these two courses; yet educators at large repeatedly treat grade points derived from different courses of study involving different teaching methods and different patterns of response as if they were additive and could be equated.

A simple example of the practice of equating average grades is in order. Let us consider the semester courses of study which students X and Y pursued in their sophomore year of college. Each course listed is given by a different teacher. The semester grades earned by each student are listed after the courses as follows: Student X—Physics=1; Chemistry=3; Calculus=2; Astronomy=1; German=2. Student Y—English Literature=3; French=1; History=1; Sociology=3; Education=1. The average semester grade of each student is 1.6. Does this mean that the two students are characterized by the same qualitative or quantitative level of educational achievement? Assuredly not, and yet this is the conventional interpretation of number grades expressed in ratio form. Two average grades of the same magnitude, when related to other functions such as hypostatized intelligence represented by composite scores, are projected into correlational frames at one definite point in a scale of magnitudes and hence treated as equivalent.

But this is not the end of this numerological scandal that persistently taints our educational process. Averages of semester grades are averaged, and these averages averaged into larger institutional averages. Dormitories, fraternities, honor societies, and campus clubs of various kinds compete with one another in terms of such spurious averages. Administrators are sufficiently sensitive about grade averages to suggest the elimination of students who do not "measure up" to a certain point level, but I believe that administrators on the whole are not sufficiently concerned about the reliability of grade points to calculate the probable error of grade averages. It was a custom in one institution to carry out grade averages to 2 decimal places in the selection of candidates for a national honorary. In some instances fraternities are differentiated from each other in scholarship by carrying out the group grade average to the fourth decimal place. Those who have worked statistically with grade points will immediately recognize that the probable error of a group grade average is suffi-

ciently large to render any expansion to additional decimal places meaningless. One fraternity is tied with a second fraternity by a group grade average of 1.796. The average is carried to the fourth place to break the tie and give one fraternity the advantage of enjoying certain honors and privileges over the other fraternity. The first fraternity receives a level of 1.7965 while the second receives a level of 1.7963. Can any one ever state what difference in the quality of scholastic achievement is indicated by the $2/10,000$ of a point in the fourth decimal place? This is, indeed, numerology with a vengeance; nominal, non-additive numbers refined to the $1/10,000$ of a point. It is quite possible, in terms of range and group variability, for one fraternal group to excel another in scholarship and achievement and yet have a lower grade average. We need a redefinition of scholarship in our institutions of higher learning and a discontinuance of the pseudo-mathematical practice called the grade-point system.

Some years ago Thorndike said "Whatever exists, exists in some amount and can be measured." This authoritative proclamation has been instrumental in shaping the devolution of psychometry and education. Every one will agree that Thorndike's influence upon psychology and education has been great, and it is not surprising to find this influence crystallizing into repeated attempts to measure many phenomena which were once thought far too complex to measure. This enthusiasm to measure whatever exists has developed into the emotionally charged delusion that abstract names of undefined objects existing in the human imagination can be measured also. Thorndike holds that intelligence can be measured just as a physicist measures distance or mass or time. On the basis of this assumption he has, unlike most of his colleagues who recognize the arbitrary range assigned to scales, constructed an absolute intelligence scale with a range extending from 0 to 43 to which he has given the name CAVD. Zero intelligence is said to be "just less than that which leads one to spit out a substance that has a very bitter taste or to retain in the mouth a substance that tastes sweet." Score 43 is supposed to represent approximately "the intelligence of a college professor." The application of this scale to human subjects reveals the verdict that 6-year old children have almost three-fourths of the amount of intelligence that a college professor has, and the mid-point of the scale is represented by a mental age not far from adult idiocy. We may consider this exhibit A of what happens when the quantitative method is applied to human response for the purpose of guaranteeing new psychological insights. Thorndike is one of a vast company of psychometricians who have devised and utilized paper tests to measure things that cannot be demonstrated to have concrete, objective reality.

If one cares to examine the hundreds of investigations in the field of mental testing that have been published in the various psychological and educational journals, he will be impressed by the futility of the many attempts to measure hypostatized abstractions. In two very recent volumes by Hunt⁴ and Guilford⁵ we are told that hypostatized abstractions such as memory, imagination, intelligence, musical talent, art talent, interest, attitude, conduct, character, and personality are measurable and have been measured. Other investigators claim to have measured general intelligence, learning capacity, emotional stability, thrift, introversion, extraversion, social adaptability, moral discernment, mathematical ability, generosity, patience, capacity for leadership, honesty, dominance, submissiveness, willpower, and many others. One might excuse many of the psychometricians if they openly acknowledged the ambiguous middle use of the term "measure." But one cannot find such acknowledgment general; to the contrary, one finds article after article and volume after volume in which the word "measurement" is emphasized and stressed. Without much effort on my part, I believe that I can convince any true scientist that psychometricians have not and do not measure any of the class names which I have mentioned nor the items which are represented by these class names.

In order to clarify this point, we might do well to review briefly the more fundamental conditions and criteria that satisfy measurement. To measure a property, we must be certain that the property exists. Thus, by way of example, length is a property of a walking stick; extraversion is not a property of a walking stick. The property to be measured must be quantitatively and qualitatively uniform and homogeneous throughout its extent. Thus, length is always length, never thickness. Nor is it confounded by any other property such as taste or odor. In order to measure the property length, there must be a unit of measurement quantitatively uniform within a specified probable error and qualitatively identical with the property to be measured. If we wish to measure as the physicist measures (which to me is the scientific method of measurement), then our scale must have a zero point as point of origin with equal units throughout its extent. Consider the centimeter as a standard unit of length. In measurement, we may say that 3 centimeters added to 5 centimeters will give a length of 8 centimeters. We may say that 45 centimeters are equal to 3 times 15 centimeters, and that 50 centimeters are equal to 10 times 5 centimeters. When we have such additive conditions obtaining, we may establish an infinite number of

⁴ T. Hunt, *Measurement in Psychology*, New York, 1936.

⁵ J. P. Guilford, *Psychometric Methods*, New York, 1936.

equalities of ratios or proportions. We may say that a distance which measures 5 centimeters is to a distance which measures 10 centimeters as a distance which measures 50 centimeters is to a distance which measures 100 centimeters. Whenever true measurement is accomplished such ratios are possible.

In the measurement of a property, the addition of quantities of the property must satisfy all the axioms of addition of cardinal numbers. If the property is denoted by nominal or by ordinal numbers only, it is non-additive and hence non-measurable.

When we examine the literature under the heading of mental tests—that is, tests of the class names previously mentioned—we do not find in any part of the literature any units which satisfy the criteria of scientific measurement. The truth is, educators and psychometricians, in applying mental tests and achievement tests, never do measure by means of such tests, either directly or indirectly. The few ratios that have been utilized by Stern, Terman, and their pupils are not true ratios of measurement. The function of an I.Q. 110 may not be equivalent to the function of another I.Q. of the same identical size. By the familiar method of scaling gross scores on an intelligence test, there is no means available for determining how much more intelligence is implied by one score than by another. It should be observed that intelligence test scores are non-additive. Psychometricians have not discovered any method by means of which we can say John is twice as intelligent as Henry, three times as introverted as Bill, six times as submissive as James, one-fourth as patient as William, with twice as much inferiority feeling as Fred.

When we return to the properties which are supposed to inhere in the list of hypostatized abstractions previously mentioned, we find so-called traits described which either do not exist observationally or else cannot be measured independently. We should remember that if a property is to be tested, that is, indirectly measured, then it must be observable and measurable independently of the property by which one proposes to test it. Moreover, the test manner must be regular, constant, and known, while the property to be tested must depend on the test-property.

Intelligence tests and personality tests do not satisfy these criteria. Through loose descriptions in articles and texts, students as well as naive laymen have been led to believe that by means of an intelligence test a person's quota of intelligence can be measured. Psychometricians lead many to believe that it is possible to tell a person to what extent he will succeed in a given endeavor if he has so much of intelligence.

To say the least, bemuddled programs of intelligence testing and personality testing are consequences of a complete misunderstanding-

ing of the fundamental axioms of arithmetic. The fact that different kinds of response can be identified by numbers does not warrant the pseudo-mathematical treatment of converting qualitatively heterogeneous activities into homogeneous coefficients from which are subjectively extracted supposedly measurable hypostatized concepts.

Intelligence and personality tests are still laboratory devices in the embryonic stage of investigation, and from the experimental point of view further investigation leading to greater refinement should be encouraged only when necessary research cautions are observed. But as a means of diagnosing or prognosing human behavior, I recommend the discontinuance of such tests in the departments of human welfare and in our institutions of learning. I believe that a frank and honest public confession of the many limitations and inadequacies of scaling techniques in psychometry and education would help to remove from the mental testing program the cataract of black-magic which has so completely blinded the layman into a naive acceptance of statistical numerology. Little does the layman realize that the professional testers utilize volumes in debate over the properties of the abstractions which they assert to measure. I have recently found twenty different definitions of intelligence in a single journal, each definition consisting of descriptions of abstractions demanding further definition. Moreover, the debate by prominent statisticians over methods of analyses of test data is no less extensive. One can obtain an excellent survey of the confusion over the past ten years in the successive volumes of the *Journal of Educational Psychology* for that period. With the number of mental tests increasing by leaps and bounds, the professional tester himself is often at a loss as to just which test to select.

The elimination of falsely appraised, invalid, and unreliable intelligence tests and personality tests from school systems would prevent much dangerous negative motivation of students who are led to believe that their relatively low test scores are indices of an unalterable deficiency in some indispensable inherited capacity. In the name of academic freedom psychologists should be given the privilege of experimenting with various kinds of mental tests under proper cautions, but the projection of mental tests of questionable validity and questionable reliability as a "standard program of diagnosis and prognosis" is a wasteful and dangerous practice, especially when the tests are given into the hands of untrained persons who sometimes pass themselves as psychometricians or mental testers. In terms of behavior adjustment to various kinds of social situations found in college and in terms of scholastic achievement expressed in grade points, the most valid and reliable intelligence and personality tests available show experimentally a forecasting efficiency that is only a few

percent better than pure guess. No one as yet has discovered any scientific and mathematically sound method of predicting a given student's course in life in the light of any score he might obtain in any intelligence or personality test. The use of the probable error of estimate of a raw score in deviation form calculated from a coefficient of correlation between some criterion adopted as valid and the hypostatized statistical entity called "intelligence" is just another example of pseudo-mathematics. The coefficient of correlation is a spurious index of forecasting efficiency when used in connection with the great mass of psychological and educational testing material. The misuse of the coefficient of correlation as an index of mutual dependence and causal efficacy has led to the false identification of the method of correlation with the method of concomitant variation. The factorial analyses, such as those advanced by Spearman,⁶ Kelley⁷ and Thurstone,⁸ are pseudo-mathematical procedures that depend on the mistreatment of coefficients of correlation as cardinally defined. Psychological components may be, by an act of professional proclamation, projected into these larger hypostatized statistical entities, but the obsolete, artificial psychological faculties attributed to these mathematical factors can not be extracted experimentally. We can not demonstrate experimentally that a certain portion of an assumed faculty of memory can be extracted from orthogonal factor matrices. Those who have investigated the method of factorial analysis in the light of measurement-criteria must hold that for psychology and education the method, whether single or multiple, is spurious and sterile.

Psychobiography and descriptions of biochemical development will, I am convinced, eventually displace the questionable, intricate statistical mazes through which more than a few investigators are groping blindly and painfully. I strongly recommend the substitution of configural analyses of dynamically interacting qualitatively homogeneous events expressed in simple percentages in place of the statistical standardization based on factorial analyses of static transverse frames of reference not compatible with the facts of mental life and mental development.

The present critical evaluation does not imply that psychometricians, educators, and social scientists can not and do not measure in their respective fields. Measurement is accomplished in these fields, but only when the criteria of measurement are satisfied in the light of some macroscopically exact and constant physical unit. Psychophysical contributions in the fields of visual and auditory sensitivity assume the nature of genuine, invaluable measurements, but it should

⁶ C. Spearman, *The Abilities of Man*, New York, 1927.

⁷ T. L. Kelley, *Crossroads in the Mind of Man*, New York, 1928.

⁸ L. L. Thurstone, *The Vectors of Mind*, Psychol. Rev., vol. 41, 1934.

be kept clearly in mind that the difference between a physical measurement and a psychological measurement is not one of kind, but of emphasis only. A physical measurement is essentially a psychological measurement; a psychological measurement is essentially a physical measurement. There is no essential difference in measurement between the two fields. In either field, psychology or physics, the standard unit of measurement is a "perceived-physical unit."

RECENT ADVANCES IN THE FIELD OF VITAMIN CHEMISTRY

L. L. RUSOFF
University of Florida

PROGRESS in the field of vitamins since their discovery in the last quarter century has been phenomenal. It is interesting to note that until a few years ago, these substances, minute amounts of which are so essential to life and well-being, seemed very elusive and there appeared little immediate prospect of determining their identity. The recent brilliant advances in this field have established the vitamins as definite chemical substances of a decidedly complex character.

All of the officially recognized vitamins,—A, B₁, C, D, E, and G or B₂ have been isolated in chemically pure form. Chemical formulas have been assigned to all, except that of vitamin E. Vitamins B₁, C, D, and B₂ have been synthesized in the laboratory and the compounds checked by physical and biological tests.

Vitamin A, fat soluble, because of its physiological properties, is also known as the growth promoting vitamin; anti-ophthalmic vitamin, anti-xerophthalmic vitamin, anti-infective vitamin, and the anti-keratinizing vitamin.

In 1928, the Swedish investigators, von Euler and Hellstrom, established the fact that animals suffering from lack of vitamin A could be cured by administering the yellow plant pigment carotene. This pigment, first found in carrots in 1831, and present in all chlorophyll-containing plants, is now recognized as the precursor or parent substance of vitamin A.

In 1930, Moore of England, demonstrated that carotene is changed to vitamin A in the liver. Measuring the absorption spectra for vitamin A and carotene was an important factor in proving this conversion. The physiological activity of carotene soon received confirmation by a host of workers in Switzerland, England, and Germany and led to the discovery of alpha, beta, gamma and iso forms of carotene. These isomers differ in melting point, solubility, specific rotation, ab-

sorption spectra, and physiological activity. The beta carotene possesses twice the activity of the other forms.

The work of Karrer and his associates in 1933 at the Chemical Institute of the University of Zurich, Switzerland, led to the structural formula for beta carotene and vitamin A. By ozonization of pure crystalline carotene or a vitamin A concentrate obtained from fish liver oils, these workers always obtained geronic acid and a number of other products. However, only half as much geronic acid was obtained from the vitamin A concentrate as from the carotene. These decomposition products, along with other tests, suggested the formulas for beta carotene and vitamin A as follows: (Heilbron at Univ. College, London has confirmed Karrer's work).

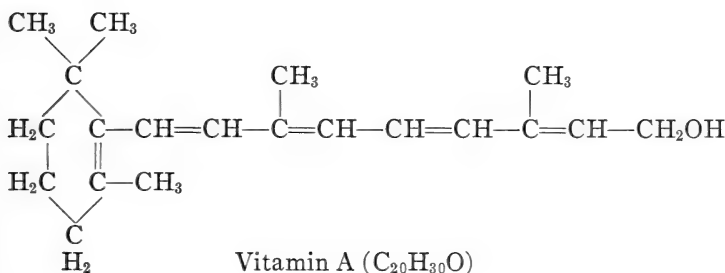
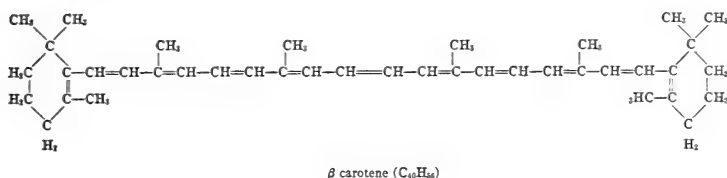

The formulas for the other forms of carotene are of the same type. Carotene might break down into two molecules of vitamin A on the addition of water to the center double bond in the molecule. Vitamin A is a clear pale, yellow, viscous oil.

Carotene and vitamin A have not yet been synthesized, although perhydro vitamin A has been synthesized by Karrer and his workers which is identical with the perhydro vitamin A obtained by hydrogenating the natural vitamin A. This compound, however, does not possess any vitamin A potency.

The spectrophotometric method of estimating vitamin A quantitatively by means of the extinction coefficient of $328m\mu$, is now used by many laboratories.

Vitamin A concerns us most in the dairy industry of Florida. Not so long ago a U.S.D.A. worker at the Florida Experiment Station intro-

duced an African Squash. Our laboratory has isolated carotene as one of its yellow pigments. The chemical tests were substantiated by the Physics department which checked its absorption spectra as that of carotene. In the near future, the Dairy department at the University of Florida intends to feed this yellow squash to dairy cows with the hope of increasing the carotene or vitamin A content of the milk. The milk will be tested biologically with rats, and checked with the spectrophotometer.

- **Vitamin B₁**—water soluble, also known as the anti-neuritic vitamin, the anti-beriberi vitamin, the anti-polyneuritic vitamin, and the appetite-stimulating vitamin.

Some years ago, the original vitamin B was found to consist of at least two physiological substances, an anti-beriberi factor (heat labile), and a pellagra-preventive factor (heat stable.) The English investigators called them B₁ and B₂ while the Americans named them B and G.

Today the vitamin B group has become complex. At least six different members have been isolated: B₁, B₂, B₃, B₄, B₅, and B₆. The picture is complicated by the fact that some investigators have introduced for some of these or different factors—vitamins H, J, K, and Y. These substances in the vitamin B group are differentiated from each other by their stability to alkali and heat, and by their physiological effect on various animals—rat, chicken and pigeon.

Of all these substances, the chemical structures of B₁ and B₂ are the only ones which have been established and verified by synthesis.

In 1932, Windaus and his associates in Germany isolated 62.3 mg. of pure crystalline vitamin B₁ as the hydrochloride, from 50,000 grams of yeast. They proposed the formula C₁₂H₁₇ON₄S. 2HCl. Williams and others confirmed this formula in the following year.

Last year (1935) Williams and his associates at Columbia obtained crystalline vitamin B₁ from rice polish. By sulfite digestion the vitamin was split quantitatively into two fractions. On the basis of chemical tests and ultraviolet absorption spectra, the following structural formula was assigned for vitamin B₁.

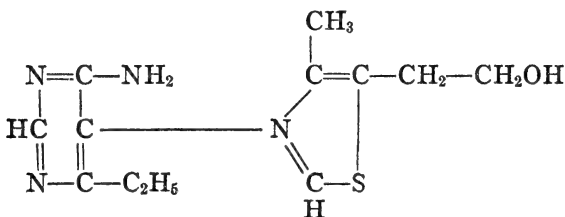

Vitamin B₁(C₁₂H₁₇N₄O S)

In August of this year (1936), Williams and Cline reported the synthesis of vitamin B₁. The compound was identical with the natural vitamin B₁ in composition, ultraviolet absorption spectra and anti-neuritic potency. It is now on the market.

Vitamin B₂—water soluble, the heat stable factor of B complex, has been called the pellagra-preventive vitamin, or the anti-dermatitis vitamin.

Within the last few years, Kuhn and his workers in Germany have shown that B₂ is indistinguishable from lactoflavin, the powerfully fluorescent pigment which occurs in the whey of milk. These workers obtained 12 grams from 220,000 pounds of whey. Kuhn and his workers and Karrer with his associates, established the structural formula for lactoflavin in 1934 and had verified it by synthesis the very next year. Other investigators have presented evidence that B₂ and lactoflavin are not identical.

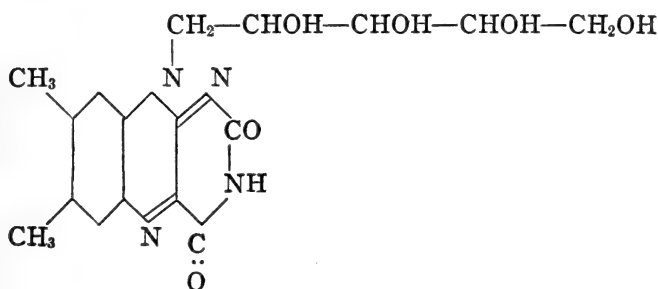

Vitamin B₂(C₁₇H₂₀N₄O₆)
(lactoflavin)

The synthetic product when tested biologically on rats to determine its physiological action showed only the growth promoting factor and not the pellagra preventive one. Thus, it is possible that B₂ consists of at least two factors; the growth promoting lactoflavin and the pellagra-preventive one.

Vitamins G and B₆ have been identified by some investigators as containing the pellagra-preventive factor. The other members of the vitamin B group have not yet been isolated.

Vitamin C—water soluble, is known as the anti-scorbutic vitamin, the anti-scurvy vitamin, ascorbic acid, ascorbinic acid, cevitaminic acid.

In 1928, Szent-Györgyi, at Cambridge University isolated a hexuronic acid, C₆H₈O₆, from adrenal cortex, oranges, and cabbage as an oxidation-reduction factor. Finding it had anti-scorbutic properties, he renamed it ascorbic acid in 1932. In that same year, King and

Smith at the University of Pittsburgh, isolated and crystallized ascorbic acid from lemon juice.

In 1933, Hirst and Haworth and their collaborators in England, making use of X-ray analyses, crystallographical measurements and spectrophotometry established the structure for ascorbic acid or vitamin C.

Later in that same year these workers announced the synthesis of vitamin C from xylososone. Reichstein in Germany also published a synthesis. Since 1933, other syntheses have been devised—one making use of glucose, reducing it to sorbitol, and then allowing a micro-organism, *Bacillus xylinum*, to act on the alcohol to change it to a ketose, an intermediary product necessary in the synthesis.

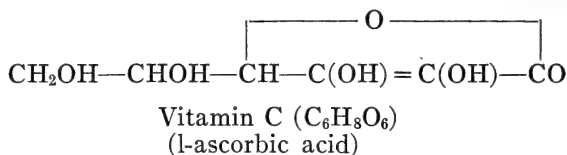

Only the form of l-ascorbic acid is physiologically potent. Ascorbic acid is sold commercially in tablet and crystalline form under the trade name of "cevitamic acid" and "Cebione."

Absorption spectra of vitamin C are now being studied to determine the vitamin quantitatively (re Rogers paper).

Vitamin D—fat-soluble, the anti-rachitic vitamin, the sunshine vitamin, the calcifying vitamin, the bonebuilding vitamin, calciferol.

In 1924, Hess of Columbia and Steenbock of Wisconsin independently announced that many foods lacking in vitamin D could obtain anti-rachitic properties by irradiation with ultraviolet light. In 1927, Windaus and Hess reported that ergosterol, a sterol, present in the skin of animals and in plant tissues, when exposed to ultraviolet formed a highly anti-rachitic substance.

In 1934, four different investigators, two in England, one in Germany, and one in Holland isolated crystalline anti-rachitic substances from the products obtained by irradiating ergosterol. The English investigators at the National Institute for Medical Research in London designated their product as calciferol which still remains today. This is known as crystalline vitamin D. The vitamin D_2 of Windaus is the same as calciferol of the English workers.

Hielbron of England and Windaus of Germany assigned the following formula for vitamin D.

Pure crystalline vitamin D—calciferol—is now prepared commercially by irradiating ergosterol under exact conditions which changes about 25 per cent to calciferol and a number of other sterols. Calciferol possesses the highest anti-rachitic property of these substances.

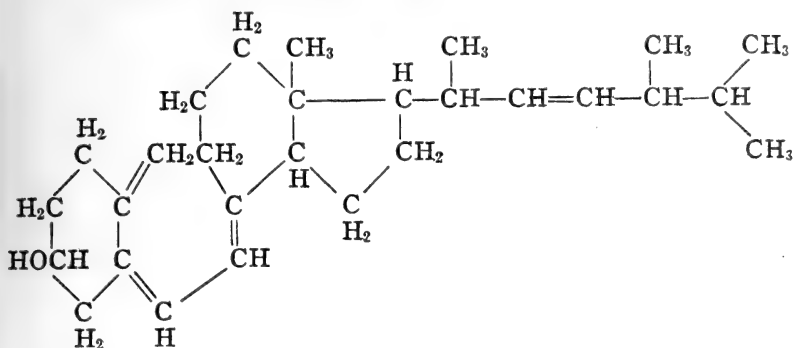
Vitamin D (C₂₉H₄₄OH)

The calciferol is precipitated with digitonum- and then forming the crystalline dinitrobenzoate, it is isolated out as the pure product. During each step, the vitamin compound is checked by optical activity, absorption spectra and other tests.

Present evidence seems to point out that at least several forms of vitamin D exist. Calciferol, (crystalline vitamin D) and vitamin D of cod-liver oil are not the same product. Not only ergosterol but also cholesterol has been shown to form anti-rachitic products upon irradiation.

Vitamin E—fat-soluble, the anti-sterility vitamin, the reproductive vitamin.

Evans and his associates at the University of California in 1935 obtained a crystalline substance from wheat germ which showed highly potent anti-sterility properties. The empirical formula was found to be C₂₉H₅₀O₂, and the compound seems to be one of the higher alcohols. The structural formula has not yet been established.

There has been a movement to fortify and improve foods which are lacking in certain mineral and vitamin nutrients. This has spread to products other than foods, so that today many commercial products contain vitamin supplements including milk, bread, yeast, cereals, cosmetics, facial soap, beverages, cough drops and candy bars.

There is much competition in selling these products by manufacturers and there has been some misrepresentation in advertisements. Unless a substance advertised to contain certain compounds is checked scientifically—i.e., shown to be physiologically potent, it should be questioned.

A normal diet containing fresh fruits, especially citrus, fresh vegetables, meats, milk and dairy products, and plenty of sunshine supply the necessary vitamins to maintain good health and well-being at all ages.

COHERING KEELS IN AMARYLLIDS AND RELATED PLANTS*

H. HAROLD HUME
University of Florida

FLOWERS in their development present many interesting phenomena. In some species a long period of time may elapse after the flower buds appear before the flowers are matured. They grow slowly, enlarge and change color even after their several parts become clearly differentiated. Sepals and petals are folded in buds in different ways and the method of folding is, in some manner, related to the time necessary for them to develop fully. As a general rule those that open slowly,—some indeed so slowly that were it not for the maturity of anthers and stigmas it would be difficult to say when they had reached complete anthesis—also last for a long time. On the other hand, the flowers of some plants mature very quickly and also they fade quickly. Growth, temperature and light are factors affecting the rate of maturity.

During a study of certain Amaryllids and some related plants, extending over a period of several years, the phenomena connected with their flower expansion have been studied. It was observed, in these groups, that the flowers of many species open quickly, so quickly that what appear to be rather tightly closed buds at one moment a few minutes later are completely expanded flowers. Immediately and without much warning they appear fully formed. A period of a few hours only may intervene between buds, in which no color shows, and well colored, completely developed flowers from the anthers of which pollen is discharged and pollination effected at once.

This behavior was first noted in the flowers of *Zephyranthes*, all species of which genus, thus far observed, behave in precisely the same manner. Flower buds progress toward maturity, perianth parts come to practically full size. They swell out like tiny balloons, then suddenly they snap open,—flowers fully developed. All preparations for the final burst are made in advance and then they expand fully almost at once. Several steps in the opening of a flower bud of *Z. Atamasco* (L.) Herb. are illustrated in Plate I. Progress is from left to right. Development from No. 1 to No. 3 is accomplished in a few hours, while, for the remaining stages, the time required is a matter of minutes.

Further study of the perianth parts revealed certain adaptations that make this interesting flower opening possible. It was observed

* Awarded the Achievement Medal for 1936.

that on the inner tip of each outer perianth segment (sepal), there is a tiny papillose elevation, a development of the central rib, and that on each side of it there is a tiny depression formed in part by the side of the elevation and in part by a slight infolding of the margin of the segment. In the folded bud two of these depressions in adjoining segment tips come together to form a larger cavity and the tips of the outer segments are held together by the interlocking of the papillae much as two brushes are fastened together by pressing the bristles of one in among those of the other. The tips of the inner segments (petals) fit into the cavities at the tips of the outer ones and so the apices of all segments, outer and inner, are locked together and remain so until growth expansion and the pressure of the inner three becomes so great as to unlock the tips. Thereupon, almost fully matured, the flower flies open. The release of the tips may be accelerated by a breeze swaying the buds about, by the visit of an insect in search of nectar, by a passing squirrel or rabbit brushing against the plant. Many times in attempting to obtain photographs of expanding buds, specimens have been collected and placed in position only to have the setting spoiled by the buds exploding, so to speak. In the Amaryllids the margins of the segments are free, and, as expansion progresses, they separate in their central or median parts, leaving spaces between, remaining attached only at their bases and apices. When in some way or other the mechanism has been damaged and the papillae fail to release, the buds do not or indeed cannot open beyond the balloon stage.

Careful examination of botanical literature has failed to reveal specific reference to these interesting structures for which the name "cohering keels" is proposed. Apparently botanists have attached no particular importance to their functioning.

To determine how generally cohering keels occur, investigations have been made in three directions. Naturally, the first and easiest was to study living, growing buds, opening flowers and fully opened flowers. This sort of material had its limitations since only a comparatively small number could be examined; no large collections have been available. Second, flowers of herbarium specimens have been examined. Here it is much more difficult to detect their presence because of their delicate fragile structure. Poorly prepared specimens yield little information, but here and there well prepared dried perianth segments show dried cohering keels at their apices. Little of form and character can be made out and nothing beyond their presence is discernible. The third source consisted of plant illustrations made by artists for such publications as the Curtis Botanical Magazine, Lindley's Ornamental Flower Garden, and Loddige's Botanical Cabinet. It is interesting to note the number of drawings in which coher-

ing keels are shown though not in detail. Since it has been impossible to cover these adequately a limited number only are listed below.* Many more might be added, but these are sufficient to illustrate the point that, while botanists seemingly overlooked them, artists who illustrated their writings portrayed them in their fine pictures.

After observing the behavior of *Zephyranthes* flowers, the study was extended to the fresh flowers of a number of other plants with the result that cohering keels have been found on the segments of species belonging to the genera *Agapanthus*, *Lilium* and *Hemerocallis* of the family Liliaceae, to *Crinum*, *Eucharis*, *Hymenocallis*, *Sprekelia*, *Habranthus*, *Cooperia*, and *Amaryllis*, of the family Amaryllidaceae, and to *Aristea* of the family Iridaceae. Certain noteworthy differences have been observed in the shape, size and elevation of the cohering keels and in the shape, length and arrangement of the papillae. In some the adjoining pits are absent. In others both the keels and pits are absent and only papillae are present on the margins of the segments, these margins acting in place of the keels. The flowers of certain species open more suddenly than do those of others. There appears to be a relationship between the elasticity and the thickness of the segments and the release of the apices. Those with thick inelastic segments open much more slowly, their tips being released without marked ballooning taking place. Indeed, so striking are these differences that they possess a certain amount of taxonomic value. Their characters within a given species are quite constant, while features presented in one species are different from those found in another. These points may be further emphasized by reference to

* References to illustrations showing cohering keels. Plants illustrated are designated by the names under which they were published; no attempt has been made to give their synonyms or to indicate the names under which they now pass.

Brunsvigia multiflora. Bot. Mag. t. 1619. Feb. 1814.

Coburgia incarnata. Lindley's Ornamental Flower Garden. t. 196. III. 1854.

Crinum americanum. Bot. Mag. t. 1034. July, 1807.

Crinum erubescens. Bot. Mag. t. 1232. Oct. 1809.

Crinum revolutum. Bot. Mag. t. 915. March, 1806.

Crinum variable var. *roseum*. Lindley's Ornamental Flower Garden. t. 195. III. 1854.

Habranthus concolor. Lindley's Ornamental Flower Garden. t. 240. IV. 1854.

Habranthus robustus. Loddige's Botanical Cabinet. t. 1761. 1831.

Hymenocallis rotata. Bot. Mag. Apr. t. 827. 1805.

Ismene calathina. Bot. Mag. t. 1561. June, 1813.

Pancratium caribaeum. Bot. Mag. t. 826. Apr. 1805.

PLATE I.

Zephyranthes Atamasco. A partly developed bud, upper left, followed by various stages leading to the opening of the flower, lower right. Flowers reduced nearly one-half, drawn from photographs.

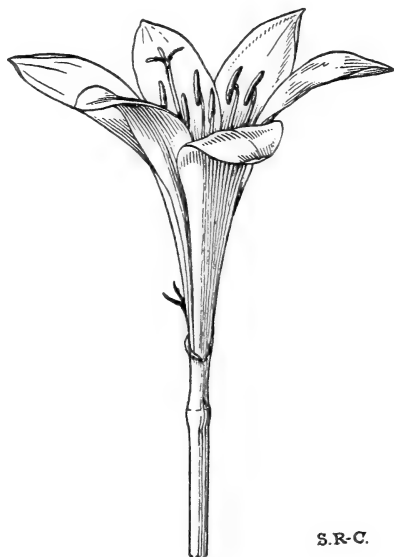
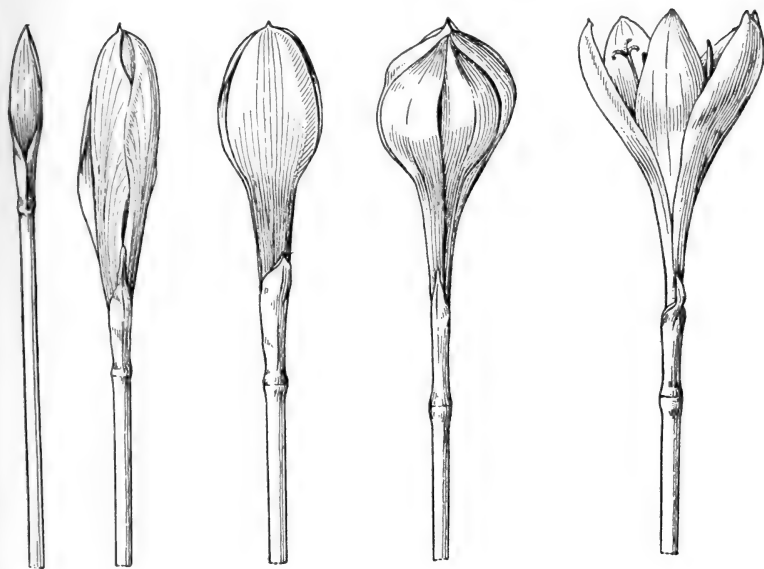

S.R.C.

PLATE I

the cohering keels found in some species belonging to the genera listed. Certain of these are illustrated, a few are not.

CRINUM

Several species of *Crinum*s are shown in Plate II. Figures 1 and 2 show two views of a sepal (outer perianth segment) profile and front of an unknown species. It will be noted that the cohering keel is elevated at the tip and furnished with long hairlike papillae. Figure 3 illustrates an unnamed species different from Figures 1 and 2. The keel is much broader and covered abundantly with long attenuated papillae. Figure 4 illustrates the tip of a *C. longifolium* segment. The keel is blunt, oblong and rounded at the tip and furnished with two kinds of papillae. Those at the tip are hairlike. A tip of a sepal of *C. Moorei* is shown in Figure 5. The tip of the cohering keel is turned backward, and the margins of the tip of the segment are papillose with short rounded papillae. Figures 6 and 7 of *C. Moorei* represent the tips of matured outer segments while Figure 8 shows a segment tip from a bud. A sepal tip from the same species is shown in Figure 9. Figure 10 shows how the tip of an inner segment (petal) is held between cohering keels on the tips of two outer segments. The limb of *C. Asiaticum*, not illustrated, is white in color and about 8.0 cm. long, surmounting a perianth tube 6 cm. in length. The incurved margins of the segments as the sharp pointed bud approaches maturity are free throughout practically their entire length. The bud is somewhat irregular in outline because of the thickened central ridges of the outer segments. These are compressed laterally at their tips. Cohering

PLATE II.

1. *Crinum sp.*, sepal, from bud, $\times 2$. Papillae long and hair-like.
2. *Crinum sp.*, sepal, from bud, front view, $\times 2$.
3. *Crinum sp.*, petal, from bud, $\times 2$.
4. *C. longifolium* var. *album*, sepal, $\times 4$. Cohering keel, thickened and elevated at an angle, papillae of two kinds, the short oblong rounded form more abundant.
5. *C. Moorei*, sepal, $\times 4$. Cohering keel densely covered with hairy papillae, its tip turned upward. Margin of sepal papillate at the tip.
6. *C. Moorei* var. *album*, sepal, $\times 2$.
7. *C. Powellii* var. *alba*, sepal, $\times 4$.
8. *C. Powellii*, sepal, from bud, $\times 2$.
9. *C. Powellii*, petal, from bud, $\times 2$.
10. *C. Powellii*, from bud, $\times 2$. This sketch shows how the petal tip is locked between two cohering keels in the unopened bud.
 - A. Sepal.
 - B. Petal.

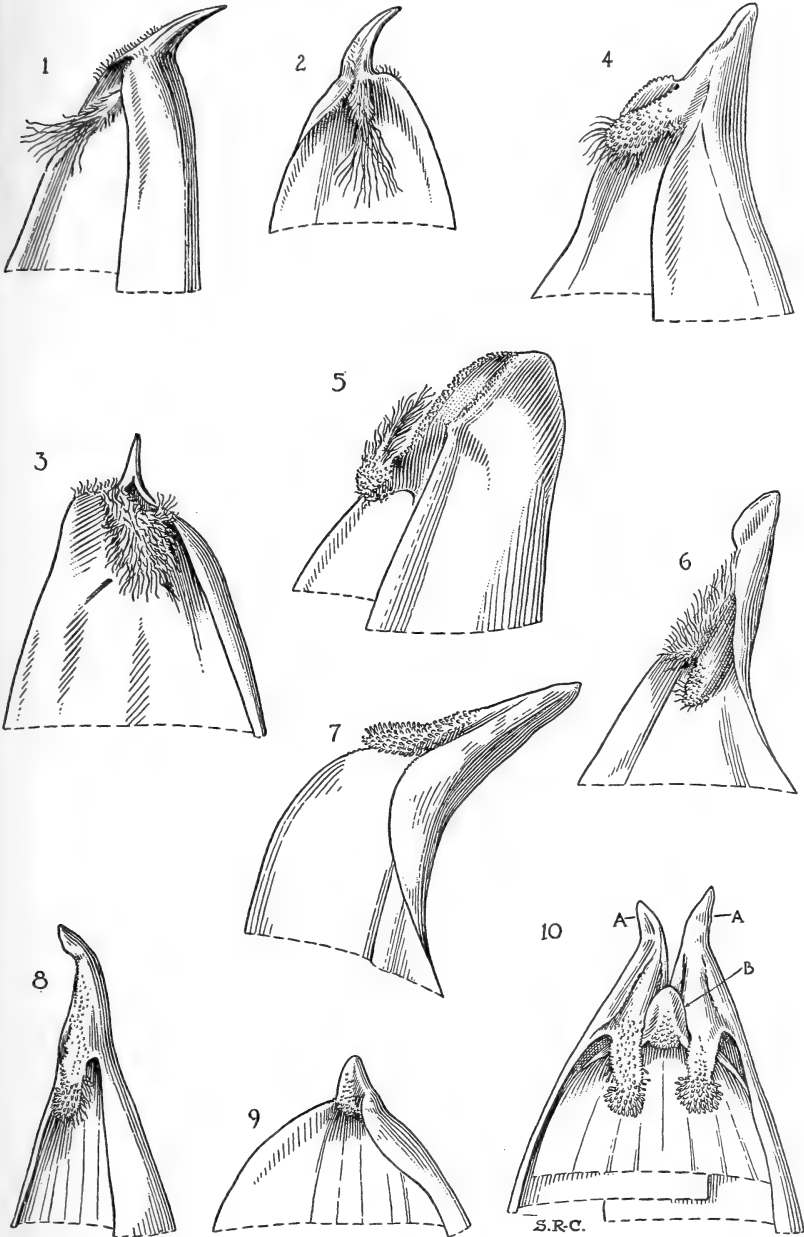

PLATE II

keels on the segments are dissimilar in shape and size. One is blunt, 1.5 mm. long, irregular in outline; a second is pointed, 1 mm. long; while the third is attenuated with a total length of 3.5 mm. The tips of the three inner segments are erose and dissimilar. The margins of the segments are incurved at their tips. At full anthesis the perianth parts are strongly recurved. Illustrations of *Crinum* have been introduced to show the variation in form of adhering keels and their papillae.

HEMEROCALLIS

Segment tips of three forms of *Hemerocallis* are shown in Plate III. (1) *H. fulva* Kwanso, (2) *H. fulva* and (3) *H. citrina*, sepals in all cases. The papillae are quite uniform but the cohering keels are different in size, shape and the angle at which they are attached to the segments.

AMARYLLIS

A segment tip of *A. belladonna* is shown in Figure 4. It will be noted that the point of the segment is strongly reflexed. The keel stands off at an acute angle and two types of papillae are shown.

ZEPHYRANTHES

Cohering keels and adjoining pits on the tips of *Z. carinata* are shown in Figure 5. They are quite typical for the genus. The petal

PLATE III.

1. *H. fulva* Kwanso, sepal, $\times 6$.
2. *H. fulva*, sepal, $\times 6$.
3. *H. citrina*, sepal, $\times 6$.
4. *Amaryllis belladonna*, sepal, $\times 3$. The cohering keel here is separated from its matrix and projects outward and downward.
5. *Zephyranthes carinata*, sepals, $\times 5$. The cohering keels and adjoining pits shown here in *Z. carinata* are typical for the genus and are followed closely.
6. *Agapanthus umbellatus*, sepal, $\times 5$.
7. *Z. candida*, sepal, $\times 6$.
8. *Z. candida*, petal, $\times 6$. The petal of *Z. candida* has a papillose tip.
9. *Agapanthus umbellatus*, expanded bud, $\times \frac{3}{4}$.
10. *L. speciosum*, $\times 4.5$. Both sepals and petals are papillose at their tips. The strong rib tips are a part of the holding mechanism.
 - A. Sepal.
 - B. Petal.
11. *L. speciosum*, $\times 2.5$.
 - A. Petal tip.
 - B. Sepal rib.
 - C. Petal rib.

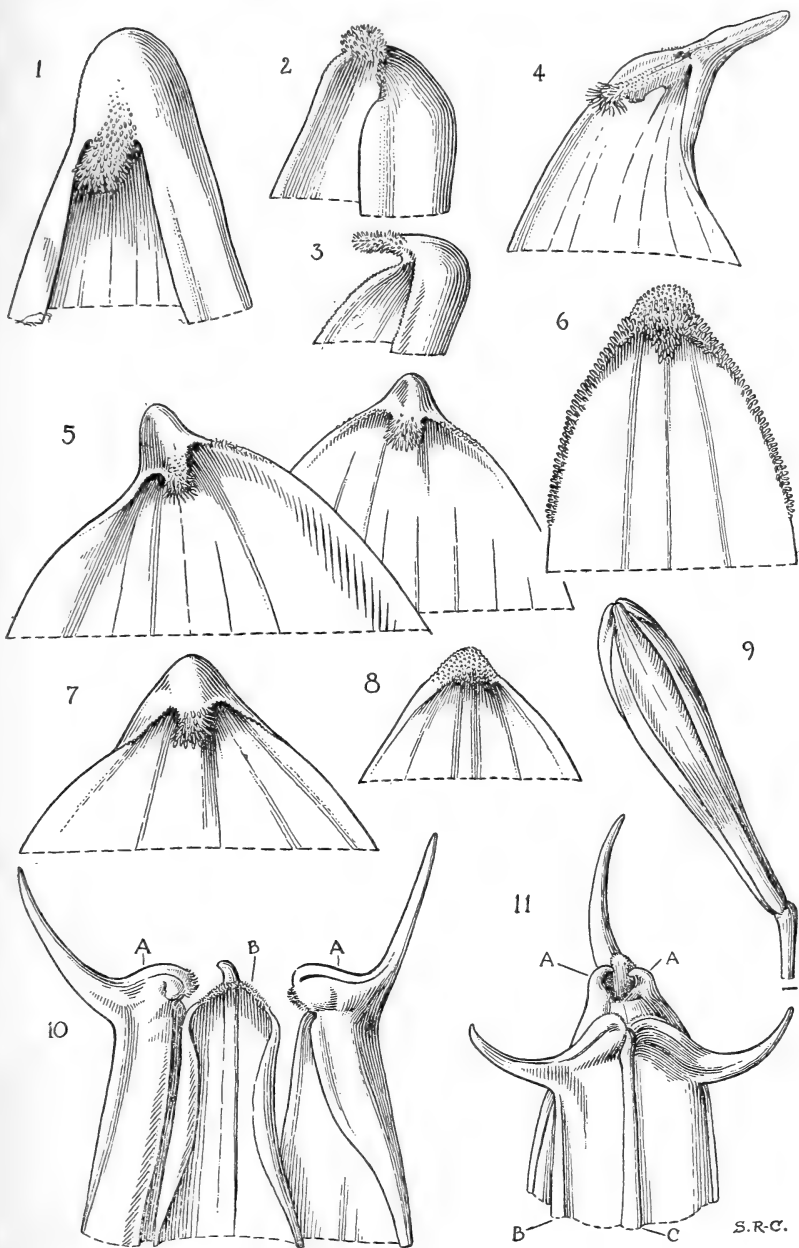

PLATE III

tips are plain, i.e., without papillae and fit into the pits formed by adjoining sepals. *Z. candida* (Figures 7 and 8) shows kinds of keels and pits but the petal tip is papillose in which respect it differs from *Z. carinata*. This plant was assigned to a new genus, *Argyropsis*, by Wm. Herbert in 1837.

AGAPANTHUS

The blunt tip of the sepal, of *A. umbellatus*, and the densely papillate area at the apex and the extension down the margins is quite characteristic. An expanded bud is shown in Figure 9, Plate III.

LILIUM

A bud tip (Figure 11) and the tips of two outer and one inner segment of *L. speciosum* (Figure 10) are shown in Plate III. Papillae are present on both outer and inner segments. The strong rib tips are a part of the cohering mechanism which differs markedly from what is found in the *Amaryllidaceae*.

EUCHARIS*

Tips of outer segments of *E. grandiflorus* are rather blunt, pits lacking, margins slightly folded inward at the tips, keel slightly elevated with abundant white papillae. The tips of the inner segments are triangular apiculate and slightly papillose. Segments of this flower are quite thick, and consequently they do not open so rapidly as in other genera.

ARISTEA (IRIDACEAE)*

In *A. capitata* the flowers are blue. On the tips of each outer segment there is a very small area covered by blue papillae. Flowers open quickly and last only a few hours.

SPREKELIA*

Cohering keels in *S. formosissima* show certain variations related to the rather peculiar formation of the perianth. The upper segment has a bilateral symmetrically balanced keel, 7 mm. long, red with white papillae. Another of the segments has a half keel and the third has a rudimentary one or none.

SUMMARY

1. Flowers of many Amaryllids and some related plants come to full maturity and then open suddenly.
2. This behavior is made possible through the presence and func-

* Not illustrated.

tioning of cohering keels, elevated papillose areas or their equivalents on the inner surfaces of the tips of the outer segments of the perianth. These have apparently been overlooked or regarded as unimportant by taxonomic and morphological botanists.

3. Cohering keels serve to hold the perianth segments closed until growth expansion releases the tips. In the meantime, the essential organs are coming to maturity and are fully developed very shortly after the flowers open.

4. It is believed that a study of a wide range of forms will develop variations in form and other characteristics that have important taxonomic value.

ACKNOWLEDGMENTS

Several members of the staff at the Royal Botanic Gardens, Kew, England, have been very helpful in working out the details of this study. Through the courtesy of Sir Arthur W. Hill, Director, opportunity was afforded for examining the flowers of several amaryllids and other plants in grounds and greenhouses. Valuable suggestions were made by Mr. A. D. Cotton, Keeper of the Herbarium, and by Dr. T. A. Sprague, Deputy Keeper of the Herbarium. The excellent detail drawings were made by Miss Stella Ross-Craig from fresh material, except where noted.

GROWTH-RING STUDIES OF TREES OF NORTHERN FLORIDA

W. L. MACGOWAN

Robert E. Lee High School, Jacksonville

THIS PAPER deals with some studies of typical growth habits of certain North Florida trees as derived from an examination of their annual rings of growth, and forms part of a research problem conducted by the writer in conjunction with and under the direction of Dr. Herman Kurz.

Observation shows that the first forest growth to cover denuded land is usually a stand of some kind of Pine. This correlates with the fact that the seeds of most Pines need full sunlight for germination, whereas the seeds of most other trees require some degree of shade. As the Pine matures, its shade prevents its own seed from sprouting. If fire does not interfere, the Pine stand will be invaded by young Oaks and Hickories, which become the dominant species in the forest as the Pines die of old age.

The Oak-Hickory association is composed of many tree species, and competition becomes so great in the understory that all but the most shade-loving trees are gradually killed for want of sufficient light. At this stage appears the Spruce Pine,—our only shade-loving Pine,

—which heralds the approach of the climax or final stage of forest growth.

The climax species in the type of forest described are Magnolia, Holly, and where they grow, Beech and Southern Hard Maple. As these trees mature, they cast so dense a shade that no tree seeds, not even their own, can germinate beneath them. Consequently this forest represents the final stage in the succession of forest growth, and

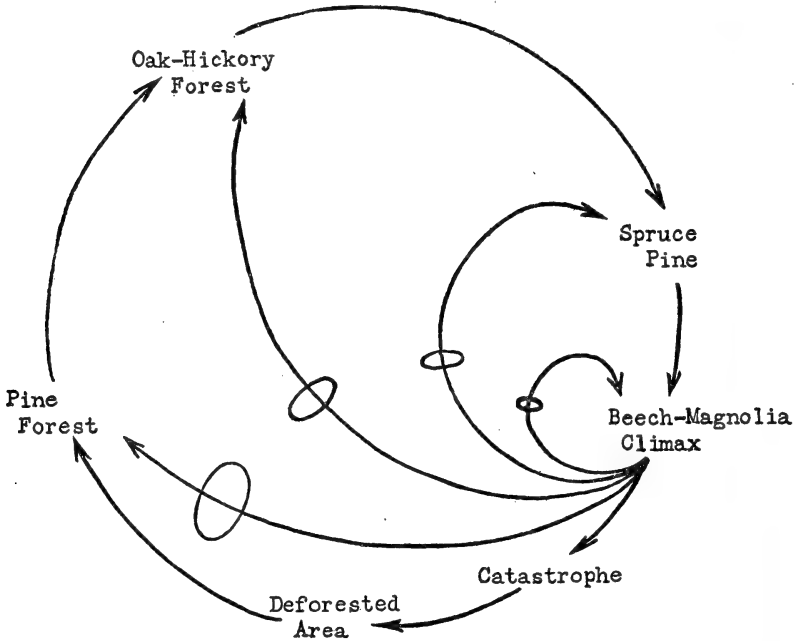

CHART I.—CYCLE OF FOREST SUCCESSIONS.

The larger the opening (represented by rings) made in the forest cover of the climax association by accident or the death of an aged tree, the farther back in the cycle the subsequent vegetation will start. A catastrophe starts the cycle again from its beginning.

tends to remain unchanged except when the death of an aged tree, or some destructive agency such as fire, wind or the axe of man makes an opening in the forest canopy.

The fall of a single tree will admit enough light to allow the germination of Oaks or Hickories. A larger opening pushes the cycle still farther back, and Pines may grow in the well-lighted center of the open space. Apparently the larger the opening made in the climax forest, the farther back the cycle is thrust. Complete destruction of the forest cover results in the repetition of the cycle, beginning with

the Pines again. Thus, barring periodic fires and other disturbing factors, each part of the forest tends to develop associations of successively greater shade-tolerance until a climax association of some form is reached. This concept is illustrated in Chart I, which shows the succession of tree associations from open ground to climax forest. This preface applies to the matter in hand in that the present study has disclosed the fact that each succession yields a characteristic growth curve which seems to be common to all members of its particular association of tree species.

To determine these growth curves a careful study of annual rings was made. Under ordinary circumstances a tree adds a layer of wood which appears as a ring in cross section just under its bark each year.

CHART II

GROWTH CURVES, PINE ASSOCIATION

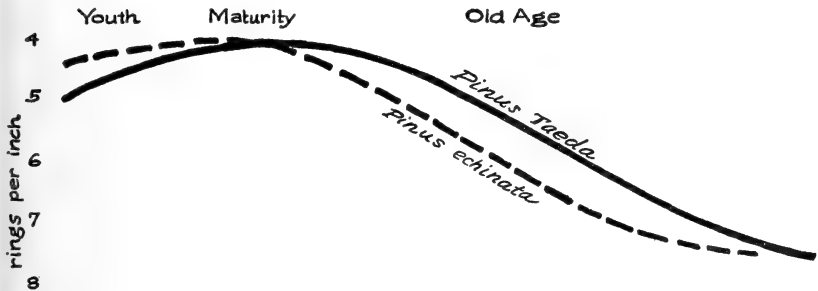

These rings are wider in younger trees and in wet warm years. Their study has led to such diverse results as the discovery of undetected long-term weather cycles and the dating of ruins. They also form a record of each individual tree's experiences, and when averaged with ring measurements of other trees of like species, yield a picture of the growth habits of that species.

Typical growth curves are shown on Chart II. The average number of rings per radial inch has been plotted for each species. The resulting straightline plots were smoothed and the curves were further generalized to compensate for conditions peculiar to each case. This is illustrated on Chart III.

The Pines originate in the open; their growth-curves show beautifully the acceleration of growth which represents the vigor of youth, the lessened rapidity of growth that comes with maturity, and the slow decline and retardation of senescence. It will be noted on the charts that the faster the growth the fewer rings per inch. Therefore a rising curve indicates acceleration, a falling curve deceleration.

The straight-line graph of the *Pinus Taeda* measurements yielded a rise in the middle of the slope of senescence. This apparently was due to the fact that beyond the low point preceding, the curve is dominated by the giants whose growth, because of favorable environment, has been more vigorous than in the case of smaller trees. To show that the growth-curve approximated reality, the small and the large trees were plotted separately. The curve of the giant Loblollies on Chart III is identical in character with the curve of all the Loblollies.

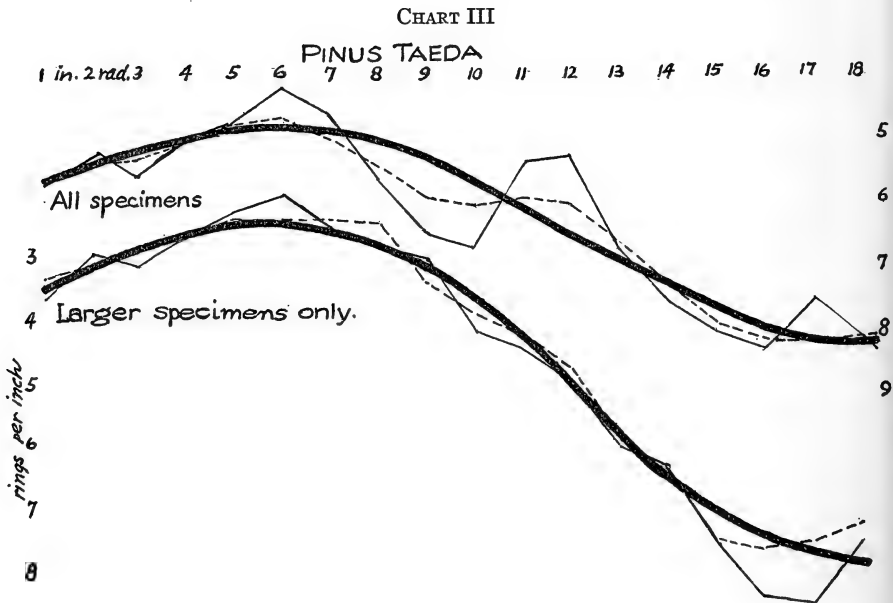

Oaks and Hickories germinate in the shade of Pines and replace them. These are shade-tolerant trees, but even so, their youth is marked by a period of struggle and slow growth which shows at the beginning of their growth-curves (Chart IV). This is due to the intense struggle for survival in the dense understory. Eventually the weaker trees fail in competition, root systems of more vigorous ones expand, and canopies are thrust up into the light. This state of affairs is reflected in rising curves of accelerated growth. For example the Mockernut Hickory as it approaches maturity shows twice the rate of growth as in infancy. The dip in the curve showing deceleration in early youth seems to be characteristic of this association.

The sub-climax Spruce Pine, and three climax trees, Beech, Magnolia and Southern Hard Maple, are shown on Chart V. Even though

CHART IV
OAK-HICKORY ASSOCIATION

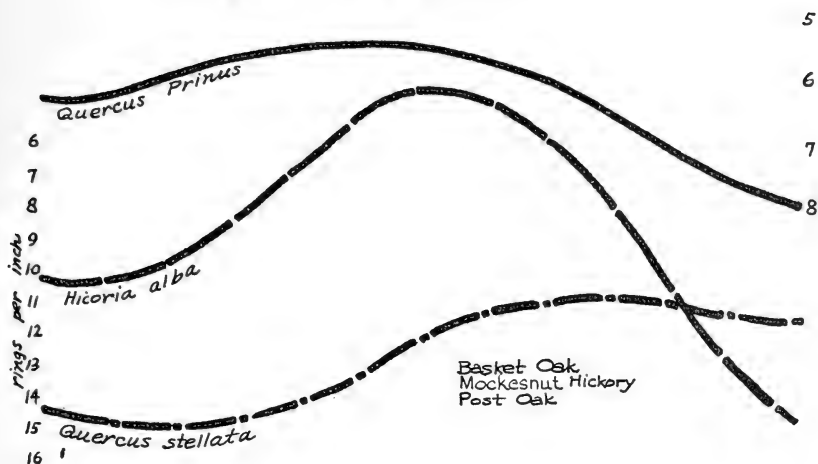
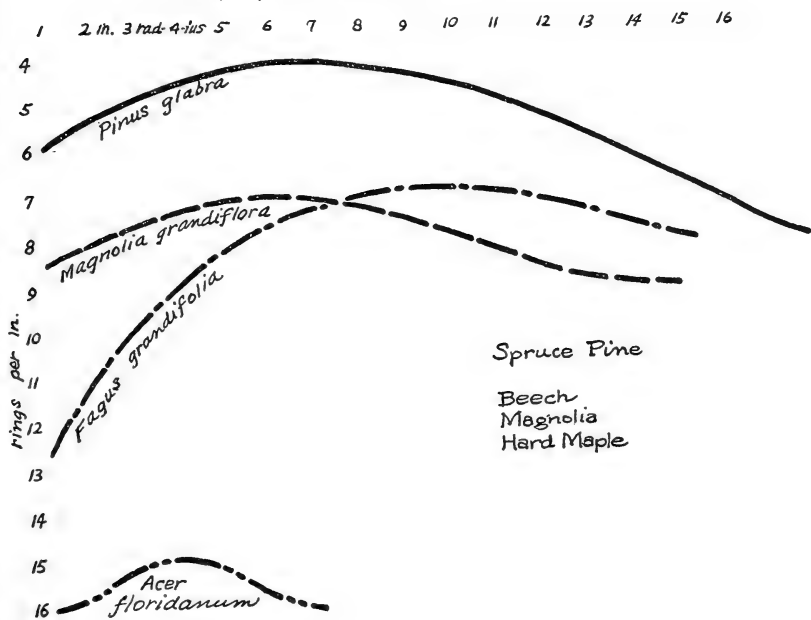

CHART V

CLIMAX ASSOCIATION



these trees start life as a rule in the dense shadows of the Oak-Hickory forest, their extreme youthful vigor and consequent acceleration of growth is shown in their more-or-less steeply rising growth-curves. This significant and consistent difference between the curves of the climax species and the Oak-Hickory group is in itself intensely interesting to the student of Ecology, for it explains why the Beech-Magnolia association tends to be the final forest to dominate an area.

The trees thus far considered grew in mesophytic habitats, or regions of moderate moisture. Some studies of other types of habitat, and of the effects of varying habitat on a species yielded some inter-

CHART VI

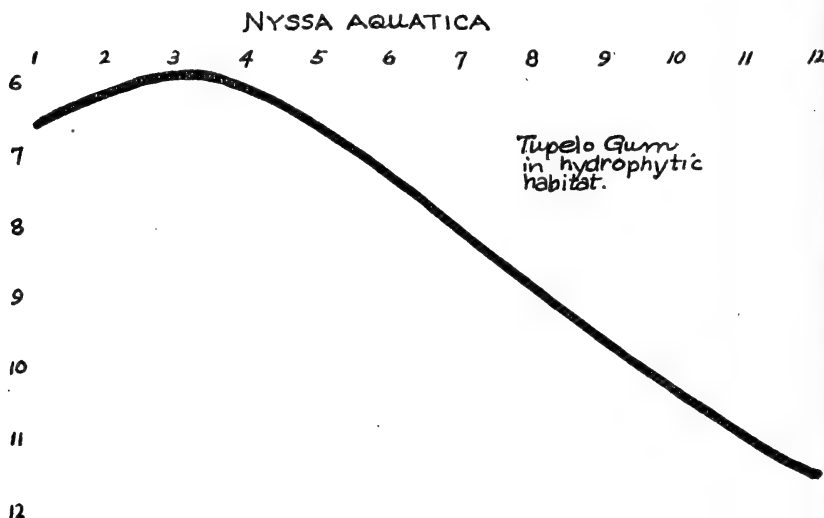

esting results. For example, Chart VI shows the Tupelo Gum, growing in a wet, or hydrophytic habitat. The curve shows the characteristic phases of youth, maturity and senescence with the last phase longer in proportion and with a steeper slope of retardation than in other species studied.

A comparison was made between Mockernut Hickory growing on the levee of the Apalachicola River with Mockernuts growing on the adjacent limestone bluff. The Hickory on the levee (Chart VII) shows no such severe struggle as its relative on the bluffs. Flanked by river and swamp, it has an adequate water supply, a rich soil, and light filtering in from river bank as well as from overhead. The Hickories on the bluff, however, show the record of a hard, losing fight. Soil is probably sparse, even though rich, drainage is too efficient and there is no advantage of light such as obtained on the levee. Hence, a

gradually retarded growth from infancy until death is self-evident.

In the case of Longleaf Pine, shown on Chart VIII, the constant retardation in growth is probably due to boxing for turpentine, and repeated fires. Adequate studies of unburned, unboxed Longleaf have not yet been completed for comparison. A study has been made, however, of burned, boxed Longleaf growing under conditions of rather extreme drought and poverty of soil. Specimens for this study were taken mostly from the dry shoulder above a large sinkhole, where limestone was overlaid with a heavy overburden of red sandy clay

CHART VII

EFFECT OF VARYING HABITAT

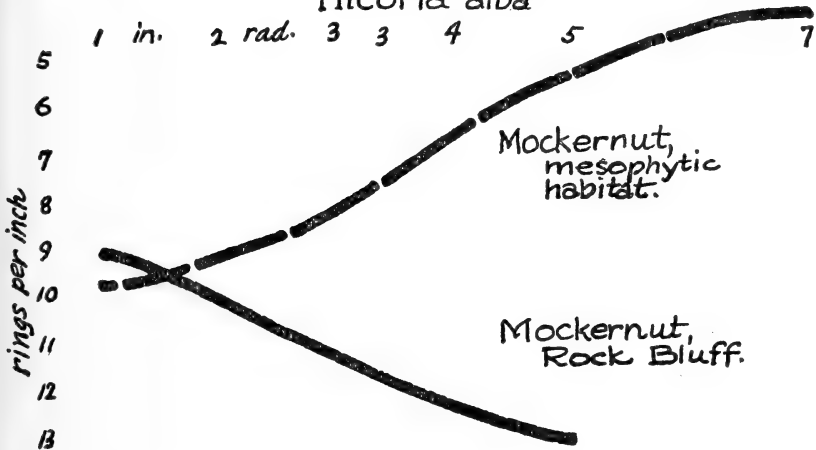
Hicoria alba

whose upper increment had been leached and bleached to a comparative whiteness. Only a sparse xerophytic or near-desert vegetation consisting mostly of tufts of wire-grass was growing here. One might expect to find a losing fight as in the case of the other Longleaf Pine, but no,—one finds exactly the opposite. The rising curve shows a continual increase in rate of growth. This is no doubt due to the fact that the Longleaf has a long tap-root, and as the root system penetrates the hardpan and increases in size and in capacity to absorb, the tree's condition steadily improves. In this habitat the near-desert conditions were those of the surface only; there was more water available underneath, although the most rapid growth found was far slower than the slowest growth of the mesophytic Longleaf.

Several trees besides the Hickory referred to were studied on the

limestone bluffs along the Apalachicola River. These are exemplified on Chart IX. Loblolly Pine shows the falling curve characteristic of most of the bluff species. The substratum of limestone evidently foiled its root system, with a result different from the case of the Longleaf Pine of the sink-hole shoulder, and not at all typical of the growth of the same species under more favorable conditions. (Refer back to Chart III.)

CHART VIII

EFFECT OF VARYING HABITAT

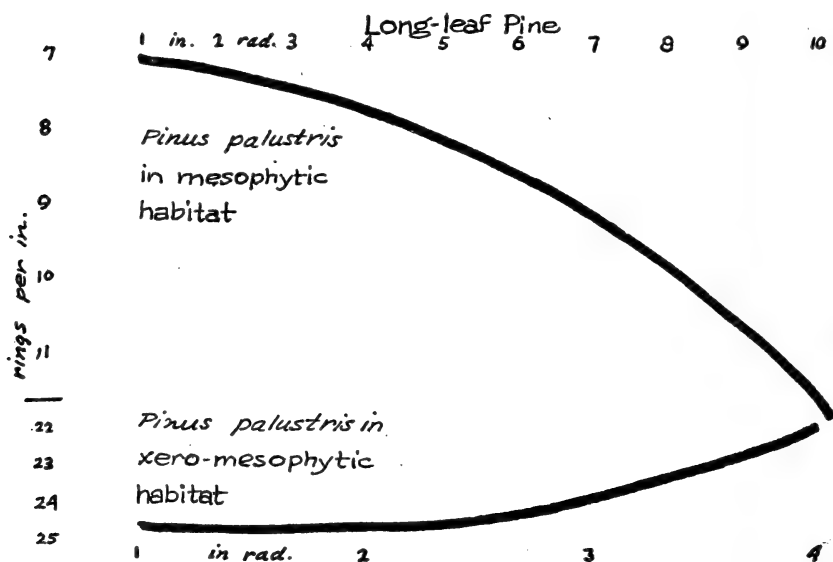

Torreya, which grows nowhere else in the world, while it is holding its own under these difficult conditions, shows also a falling curve of gradually decelerated growth. More successful is the Beech, whose growth shows no drop for many years. This is not surprising when one considers that it is a climax tree, with huge vitality in its youth. A steady rate of growth is therefore maintained over a long period in spite of the adverse conditions obtaining on the limestone bluffs.

Referring once more to the curve of Florida or Southern Hard Maple, which appears with the climax species on Chart V, we find an even more extraordinary vitality. In spite of the thin soil of the bluffs, over-drainage, and dense canopy, this species shows a speedily rising tide of youth characteristic of climax species living in more favorable

habitats. It is an eminently successful species. Its growth-curve is one of the most interesting of all. It is the only species studied whose curve shows the three ideal phases of growth under the difficult conditions prevailing on the limestone bluffs.

The studies of which this paper is an excerpt form a pioneering expedition into a large and practically untouched field, and the results of which are to be considered indicative rather than conclusive. It seems justifiable, however, to form the following tentative conclusions.

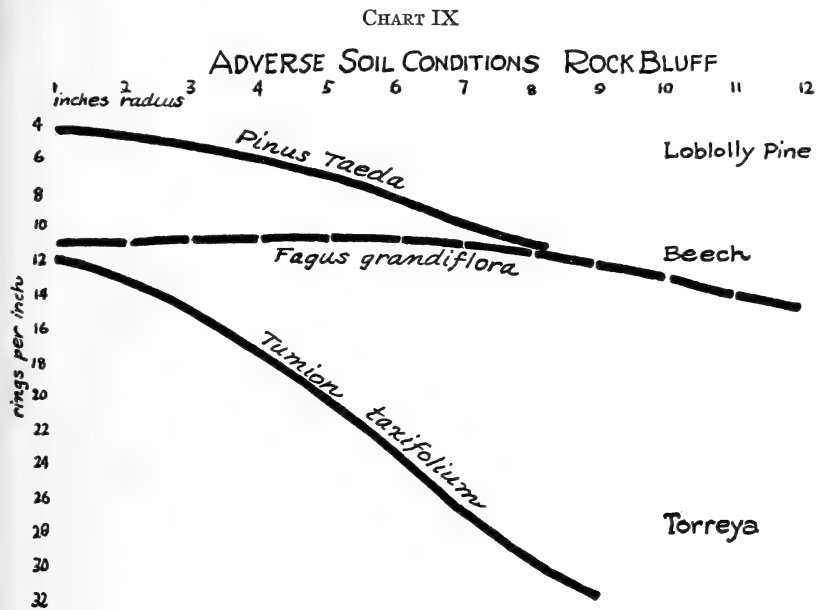

First: Rates of growth in the forest tree species studied differ according to the successional association in which the species occurs.

Second: Growth rates in each successional association of trees are characteristic and differ significantly from those found in other successional associations.

Third: Rates of growth correlate with the innate differences in vitality, structure and behavior which determine the successional type of the tree species.

Fourth: Differences in habitat involved in these studies produce definite changes in rates of growth, and the reaction of a species under different conditions is characteristic of its successional type.

STUDIES ON THE LIFE ZONES OF MARINE WATERS ADJACENT TO MIAMI: I. THE DISTRIBUTION OF THE OPHIUROIDEA

JAY F. W. PEARSON
The University of Miami

IN THE SPRING of 1928, the writer began the first of a prolonged series of class studies of underwater life off the shores and keys of the south Florida region, making use of the Miller-Dunn Divinghood and giving undergraduates their first opportunity to become acquainted with living specimens of the marine fauna in their natural habitat.

Each spring of the past three years a regularly scheduled class in Marine Zoölogy has carried on this work under the writer's direction. Almost every Saturday, weather permitting, one or two boats have carried the group down into the waters of the Bay, out around the upper keys, or out to the reef itself, out of sight of the mainland. Many studies have been made on the flats in the bay and around the shores of the keys, using a Blake trawl or plankton net at times. However, the great majority of the time has been spent under water, at depths of from ten to forty feet, where the students enter the actual environment of the living animals.

Strict discipline following careful training has so far prevented accidents during the several hundred student hours of actual diving. Though the work has its hazards, the writer believes that the benefits accruing to the students more than justify the risks. The number of helmets in use at once has ranged from two to ten, four being the most desirable number and two being an absolute minimum as well as a maximum in excessively deep water on the outer side of the reef. A minimum of three people is required for effective operation of each helmet, but long periods of diving in deeper water demand four, five or even six students to each helmet to care for the strenuous task of pumping and to provide sufficiently long periods of recuperation between dives.

Until the spring of 1934, no effort was made to chart and number stations made by the classes, but with the first offering of regular course work in Marine Zoölogy each separate collecting station has been carefully recorded and all collections and studies are readily cross-referenced. Since 1934, fifty-five stations have been established, the majority of them diving stations. With each new station that is established the variety and complexity of the minor plant and animal habitats become more evident. Several major zones may be deline-

ated, based on physical features of the land and water itself. Sub-zones or smaller divisions exist in each of these, while local variations of each sub-zone offer an almost infinite variety of associations or communities, three or four being within hose-range at one anchorage at times.

If we limit our discussion to the waters within an area formed by a line running east from Coconut Grove, Dinner Key, to Key Biscayne and thence south to a line extending from Broad Creek to Carysfort Light, we may describe the major zone as follows:

Zone I. Soft or sticky bottom, usually densely covered with *Zostera* or eelgrass, water three or more feet in depth at low tide, mainly confined to protected regions of the Bay itself.

Zone II. Flats of hard or soft bottom, exposed or almost exposed at low tide, sometimes with considerable growth of *Zostera* or eelgrass, forming large areas in the less protected region of the Bay, adjoining the mainland, or adjoining the Keys, usually on the northern or eastern sides of the keys, though sometimes to the south as well.

Zone III. Alcyonarian areas of less protected stretches of the Bay itself, usually existing also on the gradually sloping eastern and southern sides of the keys, usually with hard bottom often rocky, or with well packed shell or sand, never exposed at low tide and ranging from three to 20 feet in depth, often marked with patches or stretches of eelgrass or of completely clean bottom.

Zone IV. Relatively deep channels of rapid water between keys and up the inner side of Key Biscayne, or forming narrow passes between Bay flats, and including Hawk Channel itself, the countercurrent passage extending northeast and southwest outside the line of keys and inside the reef. These channels are often completely free of large animal life and the bottom is usually well-packed sand, shell or rock. Hawk Channel has patches of life here and there throughout it at depths that at times reach fifty feet or more at low tide.

Zone V. The coral reef extending from a point south of Key Biscayne on down outside Hawk Channel and forming the barrier that protects the channel, keys, and bay from the waters of the open sea. Of course the reef itself is rocky, completely submerged at low tide, and varies in depth and continuity. Above Fowey Rocks there is an old dead reef which shows signs of rejuvenation. Below Fowey the active reef-building corals have been steadily at work. A new line of keys should some day occupy the region now marked out by the reef.

The length of this paper does not permit inclusion of detailed lists of the many residents of each of these regions. Numerous species have been taken in each of them. Many have been identified and many others are still in process of study. The work to date bears out the assumption that while some species will be strictly limited in distribution, others will show such wide distribution as to be considered almost ubiquitous.

Centrechinus antillarum, the black, long-spined sea urchin, for example, is found almost everywhere, except in the bare channels of fast moving water and in the deeper eelgrass-covered waters of the

bay and Hawk Channel slopes. *Lytechinus variegatus*, the variable sea urchin, has a more limited distribution, being found in almost any bottom having eelgrass and occurring also in bare channels swept clean by fast moving water. *Tripneustes esculentus*, the edible sea urchin, on the contrary, has been taken only on flats having abundant life, either inside the bay or extending out eastward from certain of the keys. Likewise, *Echinometra lucunter*, the rock-boring sea urchin has been taken only in water-worn rocks on the south side of Bear Cut on Key Biscayne, while *Eucidaris tribuloides*, the club-spined sea urchin, has been taken almost exclusively by trawling in eelgrass on the shallow, sloping western side of Hawk Channel, east or southeast of Soldier Key and well off shore. *Noira atropos*, a gloriously golden little heart urchin, has been found only in knee-deep mud in perhaps twenty feet of water well up the bay inside of Key Biscayne.

Corals of one group or another, form the dominant life of certain of these zones. *Porites porites*, a small branching grey form, of which two or three varieties have been considered or rejected at various times, occurs sometimes in the eel-grass regions of deep water in the bay, but is far more abundant on certain flats and is extremely abundant south and east of most of the keys. Its little colonies remind one of a tumbled heap of giant jacks, although definite heavily branching masses also occur.

The dominant corals of rougher waters of the bay are of course the soft corals or Alcyonaria. They cannot stand emergence and rarely occur on the flats. They extend outward beyond the keys forming dense stands on the slopes of Hawk Channel as well as patches here and there, scattered among eelgrass and regions of bare sand, entirely across the Channel to the reef itself. Here, too, in many localities they are very abundant, though they rarely seem to reach the dominance they attain in quieter water, inside the reef. Rarely on the reef do they reach the size attained in the less violent water. The variety and abundance of form, color, and growth pattern attained by these bushlike colonies of soft corals in Miami waters offers infinite opportunity for the study of morphology and speciation. Often one clearly defined species will attain an almost uniform stand in one small region. Almost pure stands of the sea plume, *Gorgonia acerosa* may be found, or perhaps an almost pure stand of *Xiphigorgia anceps* or one of the species of *Plexaura* or *Plexaurella*. The writer knows of only one region of these waters where a practically pure stand of *Gorgonia flabellum* may be found. Interestingly enough this locality is on the reef itself, the old or dying reef, in the immediate vicinity of Fowey light. These sea fans are to be found almost everywhere that Alcyonaria occur, of course, but not as the dominant form.

Solid heads of stony coral may occur here and there over the sandy or rocky bottom of the bay as well as on the western slopes of Hawk Channel where they often reach tremendous size. Aside from these occasional large heads and other smaller patches, few stony corals other than *Porites porites* occur inside the reef.

While many kinds of stony corals contribute to the life and structure of the reef itself, *Acropora muricata palmata*, the elk-horn or palmate coral may be considered most characteristic. This great branching coral with its many upraised hands attaining a dozen or more feet in height at times occurs in massed colonies on all true reefs. Its dead skeletons may be recognized even when the majority of the hands have been broken off and a crenulated growth of the encrusting stinging coral, *Millepora*, has overgrown its rocky columns.

On the inner slopes of the reef the closely related *Acropora muricata cervicornis*, the stag-horn coral, a slender, low-grading form, predominates.

The Ophiuroidea will be considered in somewhat greater detail to illustrate the differences existing between the faunas of the five main regions that have been marked out in local waters. Over two thousand specimens have been studied in the data that will be presented, drawn from a considerable number of the stations that have been made since 1934. The specimens have been collected by the writer and his classes. Two students, Mr. Charles Kramer and Mr. Harold Humm, have aided in special studies that are being carried on with this group and others of the Echinoderms. The writer also is indebted to Dr. Hubert Lyman Clark of the Museum of Comparative Zoölogy, who kindly looked over a number of forms that proved difficult to determine with accuracy in the absence of an original, named collection.

Dr. Clark, in his volume on West Indian Echinoderms (1933), lists 65 species from 9 families. He reports 18 from Bermuda, 38 from Tortugas, 33 from Puerto Rico and 36 from Tobago. In the present study 33 recognized species have been collected in the Miami region, all taken by the writer and his classes. In addition to these, one other genus is represented by a young specimen, which is undoubtedly a new species, while still other puzzling forms indicate the probability that new species exist in these waters but have not yet been brought to light.

Counting the one representative of the genus *Ophiacantha*, all nine recognized families of the littoral West Indian Ophiurans are known from the Miami region and their representatives make up The University of Miami's local collection of the Ophiuroidea.

One species, *Astrophyton muricatum*, the basket-star or basket-fish, of the family Gorgonocephalidae, with its many branched arms end-

ing in tentacle-like tips, appears to feed almost exclusively on the polyps of *Gorgonia acerosa*, the sea plume, and is taken abundantly in the Alcyonarian or hard bottom zone, Zone III. It is found with its arms interlocked and wrapped tightly about a branch of the plume, forming a ball-like mass that cannot be removed forcibly without damaging the specimen.

All other littoral members of this class appear to be secretive, positively thigmotactic creatures, living in sponges, in crevices or holes in rock, under coral heads, in empty mollusc shells, in masses of coralline algae such as *Halimeda*, beneath any object resting on the bottom, or they may be found burrowing into mud or sand, perhaps to a considerable depth.

While the littoral distribution of these animals would be expected to place all of them in all 5 zones that make up the writer's collecting range, specific adaptations to specialized small niches of the general environment have acted to eliminate some entirely from certain zones, or have limited their numbers decidedly in comparison with the abundance of other forms.

Zone I, with its mud and sand, often eelgrass covered, in protected bay waters, has so far yielded the poorest fauna. Only seven identified species have been brought to light. The unique *Ophiophragmus filigraneus*, recorded here for the first time from the east coast of Florida, and the ubiquitous *Ophiactis savigny* occur with almost equal abundance in the collections from this zone. The other four species are each represented by a single specimen. One specimen of *Ampnioplus abditus* constitutes the only record for this species, while the single *Amphiodia repens* has been taken once also on the flats.

Only 6 of the 33 identified species have not been taken in what has been termed the zone of the flats, Zone II. These 6 species include *Ophiophragmus filigraneus*, which has so far appeared only in the sand of Zone I, *Amphipholis squamata*, *Amphiodia rhabdota*, *Amphioplus abditus*, *Ophiactis algicola*, and *Ophiothrix angulata*, which is typically a reef form. Nine species taken in this zone have not occurred elsewhere. Single specimens of *Ophiothrix brachyactis* and *Ophionereis olivacea* constitute the only representatives of these species. *Ophiocoma echinata*, *O. riisei*, *Ophioderma brevicaudum*, *O. appressum*, *O. cinereum*, *Ophiozona impressa* and *Ophiolepis paucispina* occur in some abundance on the flats and have been taken nowhere else. *Ophioderma brevispinum* is very abundant on the flats and has been taken once elsewhere, in the Alcyonarian zone.

Seventeen species of ophiurans appear in the Alcyonarian or moderately deep water zone of fairly hard bottom. *Amphiodia rhabdota* has come as a single specimen and from this zone alone. While more specimens have been taken from the flats than from this zone, *Ophionereis*

squamulosa has been three times as abundant here as it has been on the flats.

Poor collections have been yielded by the channel zone with nine species represented. *Ophionereis squamulosa* has been most abundant with no species appearing that has not been found elsewhere.

The reef zone with its seventeen species presents a rather unique representation of ophiurans. *Ophiothrix lineata* is the dominant form and far exceeds all others, although it has occurred but rarely elsewhere. There are indications that continued study may make it desirable to divide the reef zone into northern and southern sections. Further studies will clear up this point.

When the relative abundance of the various species is considered, it must be noted that the family Amphuridae with its 13 species is dominant in zone I, the deeper protected waters and shores of the bay. The two most abundant species of this zone belong to this family and the third most abundant form falls in the family Ophiotrichidae. Not a single specimen of any family, other than these two, has been taken in zone I.

With every family but the Ophiacanthidae represented in zone II, the Amphuridae are relatively less abundant than other families of the flats, even though *Ophiostigma isacanthum* and *Ophiactis savignyi* have been collected in great numbers. *Ophiothrix ørstedii* of the Ophiotrichidae is most abundant. *Ophiopsila riisei* of the Ophiocomidae ranks second, and *Ophioderma brevispinum* of the Ophiodermatidae is third.

The Alcyonarian or hard bottom zone, Zone III, shows *Ophionereis squamulosa* of the Ophiochitonidae as most abundant, *Ophiactis savignyi* of the Amphuridae as second in point of numbers, and *Ophionereis squamulosa* of the Ophiochitonidae as third.

The third zone, the channel zone, gives greatest abundance to *Ophionereis squamulosa* of the Ophiochitonidae, but yields second place to *Ophiothrix ørstedii* of the Ophiotrichidae, while two species of the Ophiocomidae appear in equal numbers to tie for third.

In the reef zone or fifth zone the family Ophiotrichidae completely dominates. Three species of this family rank first, second and third in abundance, namely, *Ophiothrix lineata*, *O. ørstedii*, and *O. angulata*.

In summary it may be said that the family Amphuridae offers the greatest number of species, most widely distributed, but that except for the abundant and ubiquitous *Ophiostigma isacanthum* and *Ophiactis savignyi* along with the localized *Ophiophragmus filigraneus*, these species are not well represented in the Miami area.

The Gorgonacephalidae, represented by *Astrophyton muricatum* are abundant in the Alcyonarian zone and occasionally occur in flats, or reef zones.

The family Ophiomyxidae with its single species, *Ophiomyxa flacida*, has been taken only on flats or reefs.

The rare Ophiacanthidae are practically unknown to the area.

The Ophiotrichidae, except for two rare species, are very abundant. One species, *Ophiothrix ørstedii* is ubiquitous and dominant in every zone, and this one with two others completely dominate the reef zone.

The Ophiochitonidae, with one species rare and two abundant, is well represented on the flats, while one of them, *Ophionereis squamulosa* dominates the Alcyonarian and channel zones.

While two species of the Ophiocomidae occur in all zones, except the first, these forms are primarily flats animals and reach their true importance in Zone II.

The Ophiodermatidae and the Ophiolepididae are almost exclusively confined to the shallow water and hiding places of the flats, Zone II.

Attention must also be called to the remarkable abundance of *Ophiothrix ørstedii*, which ranks third in Zone I, first in Zone II, third in Zone III, second in Zone IV, and second in Zone V.

It is hoped that this paper will offer some indication of the work that is being carried on in local waters. Space does not permit the inclusion of tables and additional data bearing upon the ecology of these and other groups of the area. Additional material brought to light by this method of class study and research will be forthcoming from time to time as the opportunity presents itself.

A KEY TO THE FRESH-WATER FISHES OF FLORIDA

A. F. CARR, JR.
University of Florida

THE FRESHWATER fish fauna of Florida is one of the most interesting in the United States. It is a fauna developed in a region of recent geologic origin, low topographic relief, poor drainage, and unusual geographic configuration, and consequently exhibits certain very peculiar features. Some of the characteristic continental groups apparently have not had time to establish themselves in the peninsula since its elevation above the sea, while others have doubtless failed to find suitable conditions in its low and swamp-bordered water courses.

Of the suckers and cyprinid minnows, which form a major element in the fauna of eastern North America, few more than a dozen occur in Florida, and several of these are confined to the extreme western portion of the panhandle. The darters, likewise widespread and abun-

dant farther north, are represented in the peninsula by only three species.

The scarcity of these common forage fishes in the state probably is due in part to the recency of the establishment of migration routes. Moreover, many of the forage fishes, and especially the darters, are adapted particularly to life in swift highland streams, where food is scarce and predators and competitors few. Such delicate fishes may find conditions intolerable in the sluggish and fertile Florida streams.

Throughout the first several million years of its history Florida was an island. Whatever fish fauna existed in its youthful drainage system must have been derived principally from marine or marine littoral forms. With the closing of the Suwannee Straits and the establishment of a link with the great land mass to the north, a new region was opened up for invasion by the continental fishes. The newcomers encountered a fish population composed chiefly of forms characteristic of brackish coastal waters. Among these the cyprinodonts were doubtless the most numerous, both in species and individuals. Today Florida's cyprinodont fauna is one of the most extensive in the world. The vigorous and adaptable centrarchids apparently found the new conditions highly favorable, for they have spread over the entire state, and with the gars, comprise a predator list almost unrivaled in the United States.

In certain Florida lakes there are found fish closely related to or (nominally) identical with marine forms of the adjacent coasts. Most of the lakes of the state have been formed by solution and collapse of underlying limestone. Some of them, however, appear to be ancient lagoons, or depressions consequent upon the elevated sea-bottom. In Lake Eustis (Lake County), which is presumably of the latter type, three of these marine relicts occur—a sheepshead minnow, *Cyprinodon hubbsi*; a glass minnow, *Menidia beryllina atrimentis*; and a needle fish, *Strongylura marina*. Although there is a poorly developed and extremely circuitous drainage connection between Lake Eustis and the Atlantic, it seems improbable that migration takes place through it.

In addition to anadromous species, which ascend the rivers to spawn, there is a fairly large list of marine or brackish water fishes which are found more or less regularly in freshwater. A pipefish and a stingaree were recently collected in the St. Johns at Welaka, nearly a hundred miles above the mouth of the river. Unsubstantiated verbal reports record these forms from various other streams and springs in the state. Flounders are fairly common in some of our large freshwater springs. The snook is abundant in many of the canals and rivers of southern Florida, and once in the Everglades, after a three day rain, I

saw several three-foot tarpon cruising the drainage ditches in an old tomato field.

The present key includes 102 species, and constitutes the first state list of freshwater fishes since 1899, when Evermann and Kendall's Check-List of the Fishes of Florida appeared. Most of the records are based upon specimens in the collection of the Museum of Zoölogy, University of Michigan, and that of the Department of Biology, University of Florida. The few records taken from the literature are from entirely reliable sources.

ACKNOWLEDGMENTS

Although I accept sole responsibility for the present form of this key and for the final selection of the criteria that have been used in distinguishing between the groups and species, I must gratefully acknowledge the other workers whose studies have made the key possible.

I am greatly indebted to Mr. Leonard Giovannoli of the Key West Aquarium, formerly of the Department of Biology, University of Florida. Data which he obtained thru extensive field work, and his unpublished key to the fishes of Alachua County have been used extensively, with his permission, in the preparation of this paper.

I am deeply grateful to Dr. Carl L. Hubbs, Museum of Zoölogy, University of Michigan, for much valuable advice, for his identifications of Florida material, and for a list of Florida fishes compiled from his own data and collections.

For assistance in securing specimens I wish to thank the following: Mr. R. E. Bellamy, Dodd College, Shreveport, La.; Dr. R. F. Bellamy, Florida State College for Women, Tallahassee; Mr. John Kilby and Mr. George Van Hyning, Wakulla Resettlement Project, Tallahassee; Mr. Herbert Braren, Ormond; and Miss Marjorie Harris, Welaka Resettlement Project, Welaka.

Mr. Horton Hobbs, Department of Biology, University of Florida, is responsible for the explanator figure, and Mr. Frank Young, of the same department, has been of great help in testing the mechanics of the key.

MISCELLANEOUS REMARKS

Directions for Using This Key.—Read the first half of couplet No. 1. If your fish agrees with the description, proceed to the couplet to which the number in the right margin directs you. However, if the first half of the first couplet does not seem applicable, read the second half. One of the two sections should describe your specimen. Continue the process of selecting the most pertinent description in each of the couplets to which you are directed until you encounter a name. If you have made the proper choice in each case this will be the name of your fish.

Scales are counted along the lateral line from the upper end of the gill opening to the last caudal vertebra. The crowded scales which often extend out onto the caudal fin are not included.

In counting **fin rays**, consider only fully developed rays, ignoring the rudimentary ones. **Soft rays** usually are forked, and appear to be jointed. **Spiny rays** are not always stiff, but they never show joint-like transverse lines, and are never branched. Spines are indicated by Roman numerals and soft rays by Arabic numerals. D. means dorsal fin; A. means anal fin.

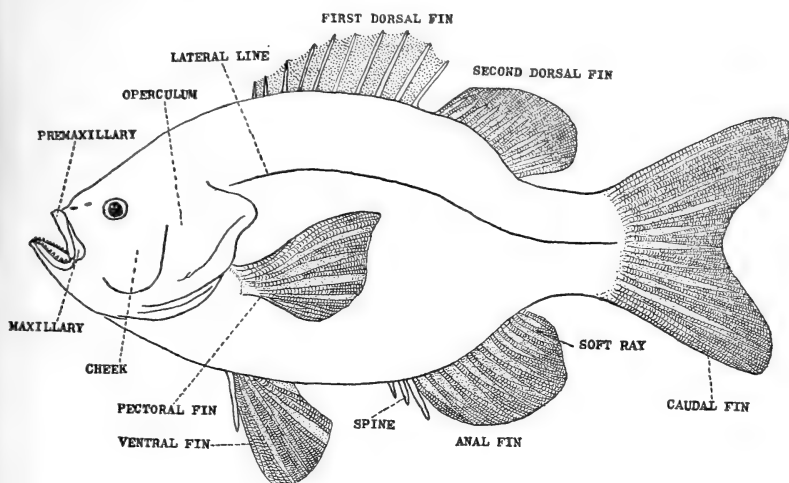

The **depth** of a fish is the greatest belly-to-back distance exclusive of fins. The **head length** is the distance from the tip of the snout to the posterior edge of the opercular flap. Where the flap is greatly extended, as in the case of some sunfish, the projection is not included. Head 4; depth 3 indicates that the head is $\frac{1}{4}$ as long as the body, and the depth, $\frac{1}{3}$ the body length. **Body length** in this key is the standard length, which is the distance from the tip of the snout to the last caudal vertebra.

The more obvious external features have been used as far as possible in separating the forms. In many cases, however, it has been necessary to use more detailed and obscure characters. In such instances the novice may have some difficulty in using the key.

In general an adult fish is much easier to identify than an immature one.

The common names used here are those held in best repute by the committee of common and scientific names of the American Fisheries Society. Local vernacular names, when included, are printed in parentheses.

GLOSSARY

ADIPOSE FIN	A thick fin without rays.
ADNATE	Fused; grown together.
BARBEL	A fleshy filament or projection, usually about the head.
BRANCHIOSTEGALS	Bony rays that support the membranes on the lower side of the head of a fish.
CAUDAL	Pertaining to the tail; the caudal fin.
CAUDAL PEDUNCLE	The region between the caudal fin and the dorsal and anal fins.
CONFLUENT	Not separated; continuous.
DORSAL	Pertaining to the back.
EMARGINATE	Slightly notched.
GILL RAKERS	The tooth-like projections along the inner edges of the bony arches that support the gills.

HETEROCERCAL TAIL	An unsymmetrical tail, whose upper lobe is often longer than the lower. The backbone may extend out into the upper lobe, or may merely curve upward before reaching it as in the case of the Bowfin (<i>Amia</i>).
HOMOCERCAL TAIL	A symmetrical tail; the backbone ends at the base of the fin and does not curve upward or enter the fin.
ISTHMUS	The ventral part of the throat and breast between the gill-openings.
LATERAL	Pertaining to the sides.
LATERAL LINE	A series of small pits or tubes forming a line along the sides of most fish.
MAXILLARIES	The outer bones of the upper jaw.
OCELLATED	Having the appearance of an eye; rounded, and surrounded by a ring of lighter color.
OPERCLE	Posterior part of the bony covering of the gill-chamber.
OVIPAROUS	Reproducing by means of eggs which hatch outside the body.
OVOVIVIPAROUS	Reproducing by means of large eggs which hatch within the body of the female.
PERITONEUM	The shiny membrane which lines the body cavity.
PREOPERCLE	Anterior part of the bony covering of the gill-chamber.
TERMINAL	At the end.
TRUNCATE	Cut off square; not rounded or forked.
VENTRAL	Pertaining to the under side of the body.

KEY TO FAMILIES

- 1 Mouth without jaws, a circular opening adapted for sucking..... *Petromyzonidae*. p. 78
Mouth with articulated jaws..... 2
- 2(1) Body disk-like; tail whip-like and longer than body..... *Dasyatidae*. p. 78
Body not disk-like; tail not like a whip..... 3
- 3(2) Tail heterocercal..... 4
Tail homocercal..... 6
- 4(3) Tail forked, its upper lobe the longest..... *Acipenseridae*. p. 78
Tail not forked, rounded..... 5
- 5(4) Mouth extended into a bill; dorsal fin short..... *Lepisosteidae*. p. 78
Mouth normal, not bill-like; dorsal fin very long..... *Amiidae*. p. 78
- 6(3) Both eyes on one side, or body very elongate and encased in a bony armor.. 26
Eyes normal, one on either side and body not encased in a bony armor; scaled or naked..... 7
- 7(6) Fins without spines, or with only one spine which is in the dorsal fin, or skin naked..... 8
Fins with spiny rays preceding the soft rays; skin with scales..... 19

- 8(7) Body covered with scales 9
 Body scaleless 17
- 9(8) Head without scales 10
 Head more or less scaly 14
- 10(9) Gill membranes free from isthmus 11
 Gill membranes united with isthmus 13
- 11(10) Lateral line wanting 12
 Lateral line present *Elopidae*. p. 78
- 12(11) Mouth not extremely wide; maxillary reaching scarcely beyond eye
 *Clupeidae*. p. 79
 Mouth very wide; maxillary extending much beyond eye . . *Engraulidae*. p. 79
- 13(10) Rays of dorsal fin 10 or more *Catastomidae*. p. 79
 Rays of dorsal fin fewer than 10 *Cyprinidae*. p. 80
- 14(9) Mouth large and terminal; body strikingly elongate 15
 Mouth small, more or less superior; body not strikingly elongate 16
- 15(14) Mouth not extended into a long sharp beak; pectoral fins inserted low
 *Esocidae*. p. 81
 Mouth a very long, sharp beak; insertion of pectorals high on sides
 *Belonidae*. p. 81
- 16(14) Anal fin of male different from that of female; intestine long, with numerous
 convolutions, or if not long and convoluted, then body and fins without bars,
 stripes, large rounded spots, or gay colors, and when pregnant, with an irregular
 black blotch on side before anal fin, and 8 to 13 very large eggs or embryos in
 body cavity; ovoviviparous *Poeciliidae*. p. 83
 Anal of male similar to that of female; intestine comparatively short and little
 convoluted *Cyprinodontidae*. p. 81
- 17(8) Body not snake-like 18
 Body long and snake-like; ventral fins lacking *Anguillidae*. p. 81
- 18(17) Barbels 8; posterior nostril with a barbel; no teeth in roof of mouth
 *Ameiuridae*. p. 80
 Barbels 4 or 6; none present on posterior nostril; roof of mouth with teeth . . .
 *Ariidae*. p. 80
- 19(7) Ventral fins abdominal 25
 Ventral fins thoracic or jugular 20
- 20(19) Gill membranes free from isthmus 21
 Gill membranes united with isthmus *Eleotridae*. p. 86
- 21(20) Vent below preopercle in adult; ventrals without spines
 *Aphredoderidae*. p. 83
 Vent normally located; ventrals with at least one spine 22

- 22(21) Dorsal fins two 23
 D. single or divided only by a notch 24
- 23(22) Anal spines III; size large *Serranidae*. p. 83
 Anal spines I or II; small species only *Percidae*. p. 83
- 24(22) Lateral line present; dorsal spines VI to XIII *Centrarchidae*. p. 84
 Lateral line lacking; dorsal spines IV or V *Elassomidae*. p. 85
- 25(19) Anal spine I; dorsal spines slender *Atherinidae*. p. 85
 Anal spines II or III; dorsal spines stout *Mugilidae*. p. 86
- 26(6) Eyes normally placed; body very elongate, encased in bony armor
 *Syngnathidae*. p. 86
 Eyes on one side of the head only; body not elongate; scales not bony
 *Archiridae*. p. 86

PETROMYZONIDAE

One species in our list: *Petromyzon marinus* Linnaeus—Sea Lamprey

DASYATIDAE

One species in our list: *Amphotistius sabinus* (LeSueur)—Stingaree

ACIPENSERIDAE

One species in our list: *Acipenser brevirostris* LeSueur—Shortnosed Sturgeon

KEY TO LEPISOSTEIDAE

- 1 Snout not twice as long as rest of head 2
 Snout twice as long as rest of head or longer
 *Lepisosteus osseus* (Linnaeus)—Long-nosed Gar
- 2(1) Large teeth of upper jaw in a single row on either side; mouth opening longer
 than rest of head 3
 Large teeth of upper jaw in two rows on either side; mouth opening not as long
 as rest of head *Lepisosteus spatula* Lacepede—American Alligator Gar
- 3(2) Distance from front of orbit to edge of opercular membrane less than $\frac{2}{3}$ length
 of snout *Lepisosteus platyrhincus* De Kay—Florida Spotted Gar
 Distance from front of orbit to edge of opercular membrane more than $\frac{2}{3}$ length
 of snout *Lepisosteus oculatus* Winchell—Northern Spotted Gar

AMIIDAE

One species on our list: *Amia calva* Linnaeus—Bowfin (Mudfish)

KEY TO ELOPIDAE

- 1 D. with the last ray extended much beyond rest of fin
 *Tarpon atlanticus* (Valenciennes)—Tarpon
 D. normal, its last ray not extended *Elops saurus* Linnaeus—Tenpounder

KEY TO CLUPEIDAE

- 1 D. with its last rays extending much beyond rest of fin; stomach like a fowl's gizzard. 7
 Last rays of D. not extended; stomach not gizzard-like. 2
- 2(1) Upper jaw not strongly notched at tip; cheeks longer than deep; no wing-like scales at base of caudal fin. 3
 Upper jaw notched at tip, the notch receiving the lower jaw; cheeks deeper than long; a pair of wing-like scales at base of caudal. 6
- 3(2) Peritoneum pale. 4
 Peritoneum black. *Pomolobus aestivalis* (Mitchill)—Summer Herring
- 4(3) Head about 4 or more; depth about $3\frac{1}{2}$; A. 19 or more. 5
 Head about $3\frac{3}{4}$; depth about $3\frac{3}{4}$; A. 18.
 *Pomolobus chrysochloris* Rafinesque—Skipjack Herring
- 5(4) D. 16; A. 19; head about $4\frac{2}{3}$; gill rakers about 35 on lower limb of arch.
 *Pomolobus pseudo-harengus* (Wilson)—Alewife
 D. 15; A. 21; head about 4; gill rakers about 23 on lower limb of arch.
 *Pomolobus mediocris* (Mitchill)—Hickory Herring
- 6(2) Depth about $3\frac{1}{2}$; gill rakers about 60 on lower limb of arch.
 *Alosa sapidissima* (Wilson)—American Shad
 Depth about 3; gill rakers about 40 on lower limb of arch.
 *Alosa alabamiae* Jordan and Evermann—Alabama Shad
- 7(1) A. 22 to 26; scales 42 to 44.
 *Signalosa petensis vanhyningi* Weed—Florida Lesser Shad
 A. 29 to 33; scales 52 to 56.
 *Dorosoma cepedianum* (LeSueur)—Northern Gizzard Shad

ENGRAULIDIDAE

One species in our list: *Anchoviella mitchilli* (Valenciennes)—Bay Anchovy

KEY TO CATASTOMIDAE

- 1 Lateral line lacking; mouth subinferior, slightly oblique; color pattern (if present) consisting of longitudinal streaks, sometimes with narrow vertical bars. 2
 Lateral line more or less developed in adult; mouth inferior, horizontal; color pattern of adult consisting of longitudinal rows of black spots, one on each scale; young pale, obscurely mottled.
 *Minytrema melanops* (Rafinesque)—Spotted Sucker
- 2(1) Scales 40 to 42; head about 4 to $4\frac{1}{3}$; A. of male not bilobed; fins more angular; D. 11. *Erimyzon tenuis* (Agassiz)—Alabama Chub-sucker
 Scales 35 or 36; head about $3\frac{1}{4}$ to $3\frac{1}{2}$; A. of male bilobed; fins rounded; D. usually 12—sometimes 11.
 *Erimyzon sucetta sucetta* (Lacepede)—Eastern Lake Chub-sucker

KEY TO CYPRINIDAE

- 1 Rays of anal fewer than 14.....2
 Rays of anal more than 14.....
*Notemigonus crysoleucas bosci* Valenciennes—Florida Golden Shiner
- 2(1) Rays of anal fewer than 11.....3
 Rays of anal 11.....*Notropis hypselopterus* (Gunther) Big-finned Shiner
- 3(2) Sides of head and lower jaw without conspicuous silvery or translucent cavities
4
 Sides of head and lower jaw cavernous, with distinct silvery or translucent
 mucus channels.....*Ericymba buccata* Cope—Silver-jawed Minnow
- 4(3) Mouth not very small, lateral cleft extending beyond anterior margin of eye..5
 Mouth very small, scarcely any lateral cleft.....
*Opsopoeodus emiliae* Hay—Pug-nosed Minnow
- 5(4) Scales fewer than 45.....6
 Scales more than 45.....
*Semotilus atromaculatus thoreauianus* Jordan—Southeastern Creek Chub
- 6(5) Lateral line extending all the way to caudal fin.....7
 Lateral line extending hardly half way to caudal fin.....
*Notropis maculatus* (Hay)—Spotted Shiner
- 7(6) A. 8; 6 rows of scales above the lateral line.....8
 A. 7; 5 rows of scales above the lateral line.....
*Notropis roseus* (Jordan)—Coastal Shiner
- 8(7) Scales about 33; head about $3\frac{1}{2}$; eye in head about 3.....
*Notropis chalybaeus* (Cope)—Iron-colored Shiner
 Scales about 39; head about $4\frac{1}{4}$; eye in head about $3\frac{1}{2}$
*Notropis eurystomus* (Jordan)—Chattahoochee Blacktailed Shiner

KEY TO ARIIDAE

- 1 Lower jaw with two barbels; dorsal and pectoral spines terminating in long
 filaments.....*Galeichthys felis* (Linnaeus)—Gaff-topsail Catfish
 Lower jaw with 4 barbels; spines without filaments.....
*Bagre marinus* (Mitchill)—Northern Sea Catfish

KEY TO AMEIURIDAE

- 1 Tail deeply forked.....2
 Tail rounded or slightly emarginate, not deeply forked.....3
- 2(1) Sides with dark spots; an unbroken bony ridge from head to origin of D.; lobes
 of tail pointed; head narrow.....
*Ictalurus lacustris punctatus* (Rafinesque)—Southern Channel Catfish
 Sides plain; bony ridge from head to D. not quite complete; lobes of tail
 rounded; head broad.....*Ictalurus catus* (Linnaeus)—White Catfish

- 3(1) Adipose fin adnate to back posteriorly.....6
 Adipose fin not adnate to back posteriorly.....4
- 4(3) Color silvery, heavily mottled with black or dark brown; anal rays about 21
*Ameiurus nebulosus marmoratus* (Holbrook)—Marbled Brown Bullhead
 Color above brownish to black, not mottled.....5
- 5(4) Lower sides and caudal peduncle with rounded light spots; rays of A. 16 to 18
*Ameiurus platycephalus* (Girard)—Flat-headed Bullhead
 Sides without rounded light spots; rays of A. 25 to 27.....
*Ameiurus natalis* (LeSueur)—Yellow Bullhead
- 6(3) Color brown to black and nearly plain; pectoral spine more than 3 in snout to
 D.....*Schilbeodes gyrinus* (Mitchill)—Tadpole Madtom
 Color yellowish, usually mottled, especially on D. and A. pectoral spine 3 in
 head or less.....*Schilbeodes leptacanthus* (Jordan)—Gulf Coast Madtom

KEY TO ESOCIDAE

- 1 Scales 108 or less; length 12 inches or less; branchiostegals 11 to 13.....
*Esox americanus* Gmelin—Bulldog Pickerel
 Scales about 125; length up to two feet; branchiostegals 14 to 16.....
*Esox niger* LeSueur—Chain Pickerel (Jack)

BELONIDAE

One species on our list: *Strongylura marina* (Walbaum)—Northern Needlefish

ANGUILLIDAE

One species in our list: *Anguilla bostoniensis* (LeSueur)—American Eel

KEY TO CYPRINODONTIDAE

- 1 Teeth pointed.....2
 Teeth notched, bicuspid or tricuspid.....17
- 2(1) Teeth in a single series.....3
 Teeth in more than one series.....5
- 3(2) Body short and deep; depth less than 4 in length.....
Rainwater Killifish—*Lucania parva* (Baird and Girard)
 Body rather elongate; depth more than 4 in length.....4
- 4(3) A black lateral stripe present from head to tail; no ocellated spot on side....
*Chriopeops goodei* (Jordan)—Red-finned Killifish
 No lateral stripe present, at least not anteriorly; side or caudal peduncle or both
 with an ocellated spot....*Leptolucania ommata* (Jordan)—Ocellated Killifish
- 5(2) Gill openings restricted above: opercle adnate to body from about root of
 pectoral upward; body short and deep.....
*Adinia xenica* (Jordan and Gilbert)—Diamond Killifish
 Gill openings not restricted above: opercle not adnate to body from root of
 pectoral upward; body oblong.....6

6(5)	Dorsal fin with 11 to 17 rays, inserted above or before anal	7
	Dorsal fin with 7 to 11 rays, inserted well behind front of anal.	12
7(6)	Scales in lateral line 33	
 <i>Fundulus similis</i> (Baird and Girard)—Long-nosed Killifish	
	Scales in lateral line 35 or more	8
8(7)	Scales more than 40	9
	Scales fewer than 40	10
9(8)	Scales about 45; dorsal with 10 rays	
 <i>Fundulus confluentus</i> Goode and Bean—Spotfin Killifish	
	Scales about 52; dorsal with 17 rays	
 <i>Fundulus seminolis</i> Girard—Seminole Killifish	
10(8)	Male with about 12 dark vertical bars and a black spot on dorsal fin; female with black longitudinal bands and 1 or 2 dark vertical bars at base of caudal fin; scales 36; depth 4; D. 12	<i>Fundulus majalis</i> (Walbaum)—Striped Killifish
	Male with scattered spots or silvery vertical bars, and sometimes a black spot on D.; female nearly plain; young male with 9 or 10 silvery bars; young female with 9 or 10 black bars; scales 35; head $3\frac{2}{3}$; depth $3\frac{1}{2}$; D. 11	11
11(10)	Longest dorsal ray about $1\frac{3}{5}$ in head; longest anal ray about $1\frac{1}{2}$ in head; base of D. 2 in head; Atlantic coastal form	
 <i>Fundulus heteroclitus heteroclitus</i> (Linnaeus)—Southern Common Killifish	
	Longest dorsal ray 2 to $2\frac{1}{4}$ in head; longest anal ray $1\frac{3}{4}$ to $2\frac{1}{3}$ in head; base of D. $2\frac{2}{3}$ in head; Gulf coastal form	
 <i>Fundulus grandis</i> Baird and Girard—Gulf Killifish	
12(6)	No distinct longitudinal bands or stripe-like rows of dots	13
	Sides with one or more dark longitudinal streaks	15
13(12)	A. 11; scales about 32	<i>Fundulus chrysotus</i> (Günther)—Golden Topminnow
	A. 8 or 9; scales 34 to 36	14
14(13)	Dark vertical bands about 15; depth about 4	
 <i>Fundulus cingulatus</i> (Valenciennes)—Banded Topminnow	
	Dark transverse bands about 12; depth about $4\frac{1}{2}$	
	<i>Fundulus notti lineolatus</i> (Agassiz)—Eastern Star-headed Topminnow (male)	
15(12)	Side with a single dark longitudinal band extending from head to tail	
 <i>Fundulus notatus</i> (Rafinesque)—Streaked Topminnow	
	Longitudinal streaks numerous and formed of black spots arranged in parallel rows	16
16(15)	In female, dark spots on scales confluent into about 6 longitudinal stripes which may alternate with rows of fainter dots; longitudinal bands indistinct or lacking in male, the vertical bands more distinct and about 12 in number	
 <i>Fundulus notti lineolatus</i> (Agassiz)—Eastern Star-headed Topminnow	
	Longitudinal rows of spots not confluent into lines, but forming series of disconnected dots	
 <i>Fundulus notti notti</i> (Agassiz)—Southern Star-headed Topminnow	

- 17(1) D. 10 to 12.....18
 D. 16 to 18.....*Jordanella floridae* Goode and Bean—Flagfish
- 18(17) Head about 3; A. 9.....
*Floridichthys carpio carpio* (Günther)—Florida Gold-spotted Killifish
 Head about $3\frac{1}{2}$; A. 10 or 11.....19
- 19(18) Depth $3\frac{1}{2}$ to $4\frac{1}{2}$; interorbital 12 to 19.....
*Cyprinodon hubbsi* Carr—Lake Eustis Sheepshead Killifish
 Depth $2\frac{1}{3}$ to 3; interorbital 8 to 11.....
*Cyprinodon variegatus variegatus* Lacépède—Southern Sheepshead Killifish

KEY TO POECILIIDAE

- 1 D. (and A. in female) with a large black spot.....
*Heterandria formosa* (Agassiz)—Least Killifish
 D. without large spot.....2
- 2(1) D. 6 to 10.....3
 D. 15 or 16.....*Mollienisia latipinna* LeSueur—Sailfin*
- 3(2) Eye in head, $2\frac{1}{2}$ to 3; head $3\frac{3}{8}$; D. 7.....
*Gambusia affinis affinis* (Baird and Girard)—Western Mosquito-fish†
 Eye in head, $3\frac{1}{2}$, head 4; D. 8.....
*Gambusia affinis holbrookii* (Girard)—Eastern Mosquito-fish

APHREDODERIDAE

One species in our list: *Aphredoderus sayanus* (Gilliams)—Pirate Perch

KEY TO SERRANIDAE

- 1 D. VIII–I, 10; A. III, 6; head $2\frac{3}{8}$ to 3; depth 4 to $4\frac{1}{2}$
*Centropomus undecimalis* (Bloch)—Northern Robalo (Snook)
 D. IX–I, 12; A. III, 2; head about $3\frac{1}{2}$; depth about $3\frac{1}{2}$
*Roccus saxatilis* (Walbaum)—Striped Bass

KEY TO PERCIDAE

- 1 Scales fewer than 44.....2
 Scales more than 44.....3
- 2(1) Lateral line incomplete, tubes usually not reaching penultimate scale in longitudinal series; depth more than 5.....
*Villora edwini* Hubbs and Cannon—Brown Darter
 Lateral line complete, at least as far as next to last scale; depth less than 5...
*Poecilichthys jessiae swaini* Jordan—Southern Swamp Darter

* Occasionally found in an abnormal phase, in which the entire body is heavily blotched with black; the ground color may be silvery or greenish gold.

† The typical race has not been recorded from Florida, but intergrades between it and the following form have been found at Pensacola.

- 3(1) Soft rays of A. 6 or 7; scales fewer than 57.....4
 Soft rays of A. 9 or 10; scales more than 57.....5
- 4(3) Soft rays of A. 6; premaxillaries separated from the forehead in the middle by a groove.....*Doration davisonii* Hay—Speck
 Soft rays of A. 7; skin of middle of upper jaw continuous with that of forehead
*Holelepis barratti* (Holbrook)—Florida Swamp Darter
- 5(3) Anal spines II; dorsal spines XII.....
*Hadropterus nigrofasciatus* Agassiz—Crawl-a-bottom
 Anal spine I; dorsal spines VIII to X.....
*Ammocrypta beanii* Jordan—Coastal Sand Darter

KEY TO CENTRARCHIDAE

- 1 Dorsal and anal fins nearly equal in length.....2
 A. distinctly shorter than D.....3
- 2(1) Dorsal spines XI to XIII.....*Centrarchus macropterus* (Lacépède)—Flier
 Dorsal spines VII to VIII.....*Pomoxis sparoides* (Lacépède)—Black Crappie
- 3(1) Tail rounded, not forked.....4
 Tail forked, or at least emarginate.....6
- 4(3) D. with IX spines, the median ones not elevated.....5
 D. with X spines, some of the median ones elevated beyond rest of fin.....
*Mesogonistius chaetodon* (Baird)—Black-banded Sunfish
- 5(4) Opercular spot large, more than half the size of eye; sides with 5 to 8 distinct vertical bars of black.....*Enneacanthus obesus* (Girard)—Banded Sunfish
 Opercular spot small, less than half the size of eye; vertical bars narrow and indistinct or lacking; male with iridescent blue or purple spots on body and vertical fins.....*Enneacanthus gloriosus* (Holbrook)—Blue-spotted Sunfish
- 6(3) D. not divided by a deep notch; depth $2\frac{1}{2}$ or less.....7
 D. divided by a deep notch between soft and spinous portions; depth 3 or more
14
- 7(6) Mouth large, maxillary reaching middle of eye; lingual teeth usually present..8
 Mouth small, maxillary not reaching middle of eye; lingual teeth usually absent.....9
- 8(7) Anal spines 6 or 7.....*Ambloplites ariommus* Viosca—Southern Rock Bass
 Anal spines 3.....*Chaenobryttus gulosus* (Cuvier)—Warmouth Bass
- 9(7) D. without black blotch at base of last rays.....10
 D. with a large, more or less diffuse black blotch at base of its posterior rays; pectoral fins pointed; black of opercular spot reaching edge of flap, no pale or colored margin in adult.....*Helioperca macrochira* (Rafinesque)—Bluegill
- 10(9) Black opercular spot short and broad, not longitudinally elongate in adults; usually no blue on sides of head.....11

- Black spot on operculum more or less elongate longitudinally in adult; blue streaks on head.....13
- 11(10) Pectoral fins rounded, shorter than head; usually with lateral rows of black or red spots.....12
Pectorals pointed, longer than head; not regularly spotted; sometimes with 9 or 10 irregular vertical bars; in fresh specimens a red or orange edge to posterior and ventral part of dark opercular spot.....
.....*Eupomotis microlophus* (Günther)—Stump-knocker (Shell-cracker)
- 12(11) Numerous longitudinal rows of small, dark spots usually present on sides, at least ventrally; 7 rows of cheek scales.....
.....*Sclerotis punctatus punctatus* (Valenciennes)—Black-spotted Sunfish
Male with about 14 rows of red spots along sides; 4 rows of scales on cheeks; belly orange with red spots.....
.....*Sclerotis punctatus miniatus* (Jordan)—Red-spotted Sunfish
- 13(10) Opercular spot with a pale or colored margin; cheek scales in about 4 or 5 rows; ventrals reaching anal; scales on belly in front of ventrals not much smaller than those of lower sides.....
.....*Xenotis megalotis marginatus* (Holbrook)—Florida Long-eared Sunfish
Opercular spot without pale or colored border, black to the edge in adults; scales on belly in front of ventrals much smaller than those on lower sides; cheek scales in about 7 to 9 rows; ventrals not reaching origin of anal.....
.....*Lepomis auritus solis* (Valenciennes)—Southern Red-breasted Sunfish
- 14(6) Dorsal almost completely divided into two; maxillary in adult extending beyond eye; no scales on soft dorsal and anal.....
.....*Huro salmoides* (Lacépède)—Large-mouthed Bass
Dorsal not nearly divided into two; maxillary not extending beyond eye; scales on soft dorsal and anal.....15
- 15(14) Sides plain or with a dark longitudinal band; scales 59 to 66; soft rays of D. 11 or 12.....*Micropterus pseudaplites* Hubbs—Spotted Bass
Sides plain or with vertical bars; scales 72 to 75; soft rays of dorsal 13 to 15..
.....*Micropterus dolomieu* Lacépède—Small-mouthed Bass (Introduced)

KEY TO ELASSEMIDAE

- 1 A round black spot on side; dorsal spines V; scales 38 to 45.....
.....*Elassoma zonatum* Jordan—Banded Pigmy Sunfish
No round black spot on side; dorsal spines III or IV; scales 27 to 30.....
.....*Elassoma evergladei* Jordan—Everglades Pigmy Sunfish

KEY TO ATHERINIDAE

- 1 A. I, 16 or 17; scales about 39; length of upper jaw about equal to eye.....
.....*Menidia beryllina atrimentis* Kendall—Freshwater Glass-minnow
A. I, 23; scales about 72; eye $1\frac{1}{2}$ in upper jaw.....
.....*Labidesthes sicculus vanhyningi* Bean and Reid—Florida Brook Silversides

MUGILIDAE

One species in our list: *Mugil cephalus* Linnaeus—Striped Mullet

KEY TO ELEOTRIDAE

- 1 Depth 4 or more; soft rays of A. 8; scales more than 40.....2
 Depth about 3; soft rays of A. 9 or 10; scales about 33.....
*Dormitator maculatus* (Bloch)—Fat Sleeper
- 2(1) Scales 40 to 46; depth about $4\frac{1}{4}$
*Eleotris amblyopsis* (Cope)—Large-scaled Slender Sleeper
 Scales about 62; depth $4\frac{1}{4}$ to 5.....
*Eleotris pisonis* (Gmelin)—Fine Scaled Slender Sleeper

SYNGNATHIDAE

One species in our list: *Syrichtes scovelli* (Evermann and Kendall) Scovell's Pipefish

ARCHIRIDAE

One species in our list: *Trinectes maculatus* (Rafinesque)—Northern Round Sole

THE GULF-ISLAND COTTONMOUTHS

A. F. CARR, JR.
University of Florida

FOR SEVERAL years and from many quarters I have heard vague tales of appalling numbers of snakes inhabiting the little Gulf islands in the vicinity of Suwannee Sound. Visiting sportsmen have returned with incredible stories of their numbers. The inhabitants of the little coastal towns of the neighborhood, though at great variance in their interpretations of the taxonomic status of the form, are all agreed that the island brand of snake possesses a biotic potential more vigorous, a venom more lethal, and a disposition more treacherous and vindictive than any other North American reptile.

An attempt to formulate a coherent concept of the serpent or serpents responsible for the harrowing reports met with little success. The more conservative of the narrators identified the species as copperhead; the more imaginative pronounced it sea cobra. Between these extremes of nomenclature were proposed such picturesque names as stump moccasin, stump-tail viper, salt-water rattler, and mangrove rattler. I discussed the matter at some length with an old fisherman who had lived many years on one of the islands. His observations had led him to conclude that there were four kinds of snakes on the keys off the Suwannee Delta—all equally deadly. The rarest of these he described as a rough-scaled tan snake with long

stripes; for this creature he knew no name. Then there was the common black stump moccasin which used to eat his young chickens, the copperhead with bright colors and foul temperament, and worst of all, the little green-tailed water rattler, which never attained a length of more than 18 inches, and from whose bite recovery was impossible.

Those of you acquainted with snakes, perhaps, will wonder why I did not immediately identify the species described in the fisherman's account. The first in his list could be none other than the marine littoral *Natrix clarkii*, while the last three are obviously stages in the pattern development of the cottonmouth moccasin, *Agkistrodon piscivorus*. In defense I can only remind you of the attitude of slightly pained, though conciliatory, unresponsiveness with which the professional zoölogist always receives the reports of the amateur. He expects to learn nothing of importance and, consequently, rarely does.

But cottonmouths they were, and, the establishing of the fact was an experience fraught with excitement as well as ecological interest.

On April 4, 1934, a group from the Department of Biology embarked on a general collecting trip to the islands off Cedar Keys. The party was composed of Mr. Buck Bellamy, Mr. H. K. Wallace, Mr. J. D. Kilby, Mr. T. D. Carr, Mr. Herbert Braren and myself. We located our camp on the beach at the south end of Seahorse Island, which lies about five miles northwest of Cedar Keys.

Seahorse is a roughly crescent-shaped, fairly well wooded island, two or three miles long, with a large population of hogs, a boarded cistern for them to wallow in, and an abandoned lighthouse on its highest point.

We arrived rather late and set about making preparations for retiring. Kilby, objecting to the arenaceous nature of the communal couch, retired to a distance of fifty yards or so back of the beach, where the grass was thicker. Suddenly we heard shocking language in his quarter and he emerged in great haste, shouting that he had laid his blankets on two adult cottonmouth moccasins, and dragging the mutilated corpse of one of them to support his story.

Stimulated by this experience, the party dispersed to explore the island. Within an hour three more moccasins were discovered. One of them was coiled at the base of a cabbage palm near the beach; the other two were nearly trodden upon in the trail leading from the beach up to the lighthouse.

On the following morning we set out to investigate the validity of the name Snake Key, as applied to another little island four miles off the mainland to the south of Seahorse. We found it to be a narrow strip of land about a mile long and a quarter of a mile wide, bordered along two sides with a thick growth of red mangrove. Inside the island we were surprised to discover a well-developed forest of shore bay

Tamala littoralis, with scattered cabbage palms, and little undergrowth other than an occasional patch of wild pepper bushes. The ground is overlaid by a thick carpet of bay leaves, and the sunlight, filtered and broken by the interlocking limbs above, falls in a pleasing mosaic on the forest floor. The whole aspect is very reminiscent of a high hammock on the mainland.

As we sauntered slowly through one of the long aisles among the trees, I happened to direct my glance downward. There at my feet was a young cottonmouth, neatly coiled, his pattern blending perfectly with the chiaroscuro of the background. I impaled him with a thrust of a frog gig which I was carrying. Turning to exhibit my capture to Bellamy, six feet behind me, I again looked down. To my alarm I perceived a broad, black head, belonging to a body hidden under the leaves directly in Bellamy's path, where he could not fail to step on it. Since his feet were clad only in low quarter tennis shoes, and since the two steps that would place him squarely over the snake were being executed with energy, I made recourse to the only means of stopping him that I could conceive on the instant—I jabbed him viciously with the gig, adorned though it was with the still-living cottonmouth. Bellamy was justly outraged at the act, while Kilby and Tom, who brought up the rear, regarded the scene with grieved astonishment. As I pointed out the cause for my show of violence, the latter two suddenly uttered cries of warning and scaled a nearby tree with great alacrity. From a branch they indicated the position of a third moccasin lying a few feet away and nearly covered by leaves.

After a brief period devoted to recovering a semblance of composure, we bagged the three snakes and resumed our interrupted stroll.

During the course of our traversal of the island we caught ten more cottonmouths. We didn't go out of our way to search for them—we merely tried to avoid stepping on them. It was with some relief that we reached the opposite end of the island. We returned to the boat by the way of the beach.

It is very difficult to account for the presence of such a tremendous cottonmouth population in a situation of this nature. We found no trace of fresh water on the island. The only other terrestrial vertebrate that we encountered was the skink, *Eumeces inexpectatus*, which was fairly abundant among the dead leaves in the woods. The bay trees harbored a large number of wading birds, most of which were nesting; we identified the following species: Ward's, little blue, little green, snowy, Louisiana, and black crowned night herons. We saw no sign of rabbits, rats, or other small mammals, and terrestrial birds were very scarce. Apparently then, the food sources available to the snakes are three in number: the heron rookery, the skink colony, and the marine fish population.

The herons are there for only a short period of each year; even then, the most to be expected from them is the occasional toppling out of the nest of an egg or fledgling. The skinks, though perennial inhabitants, are small, very nimble, and apparently not much more numerous than the snakes. Salt water fish are plentiful enough, but it is difficult for me to envision a cottonmouth pursuing its prey in the open Gulf or a mangrove swamp. The improbability of the occurrence of this perversion is attested by the fact that, though on several occasions we have walked around the island and through the mangrove swamp, we have never encountered one of the snakes near the water, or in fact anywhere except in the dry woods in the interior.

The possibility of temporary, seasonal, or sporadic occupancy of the island by the moccasins seems to me very remote. I have seen other terrestrial and freshwater snakes in salt water—on two occasions, rattlesnakes,—but I never saw or heard of a cottonmouth voluntarily taking to the sea.

A tabulated account of the stomachs of the thirteen snakes taken on the island is presented here:

No.	Age and sex	Stomach contents
1.	yearling	none
2.	adult female	3 heron feathers
3.	adult male	heron feathers
4.	young female	none
5.	adult male	bird bone
6.	adult female	bird bones
7.	young female	1 skink (<i>Eumeces inexpectatus</i>)
8.	adult male	none
9.	adult female	1 skink (<i>Eumeces inexpectatus</i>); 3 fish all under one inch in length; 1 heron egg shell
10.	adult female	none
11.	yearling	none
12.	adult female	none
13.	young male	none

It will be noted that the most salient general feature of the stomachs is their vacuity.

The most interesting item in the list is the three small fish found in No. 9. No. 9 was the biggest snake we caught, measuring four feet ten inches. The fish were very small, two of them were *Cyprinidon variegatus*, three quarters of an inch long; the third, an atherine resembling *Menidia*, was less than a half inch in length. The necessity for believing that this massive serpent had engulfed these tiny fry with the aid of dental equipment too heavy for prey five times their size was disturbing. It was with relief that I finally realized that I had picked the fish, with forceps, out of an eggshell and had laid them

aside for identification. Sensing a way around the impasse, I returned to the eggshell and inspected it carefully. There to my satisfaction I found on its inner wall two spots of white guano and a streak of dried mud. The snake was vindicated. She had not eaten the fish at all, but merely an old eggshell with the smell, or taste, or aura of fish and bird about it. The mother heron had caught the fish, and the sloppy youngsters had spilled them into the eggshell in the bottom of the nest. At a subsequent housecleaning the shell had been ejected. Mingled with my satisfaction at the neat deduction was a feeling of pity for the cottonmouth. How the shell was ingested without being crushed to bits I cannot imagine.

Two observations which I find in my notes on the moccasin hunt impress me as being of such an esoteric nature that mention is made of them here with the greatest trepidation. I record them only as statistical facts, with the assurance that I have conceived no explanation for them.

Of the thirteen snakes encountered, five of them were young, with the juvenile pattern of alternating wide bands of brown and gray, while the remaining eight were old individuals of uniform black coloration. The young ones were all found lying in the open on top of the leaves, where they presented the most remarkable example of protective coloration that I have ever seen. Two of the eight black ones were crawling over the ground, but the other six were without exception coiled beneath the leaf mold, with only the head protruding.

Further, out of the thirteen snakes, all but the two which were moving about were located under trees in which there were heron nests.

I leave to your discretion speculations as to whether and how the young snakes knew they were protectively colored, and the old ones that they were not. Moreover I disclaim all responsibility for their lying under the nesting trees, and know no more than you whether or how they knew they were under nests and that sooner or later an egg or a young bird or a fish would fall out.

In fact there is little about these island cottonmouths that I do understand, except that seven months later, during their breeding season, we came upon a three foot male and a monstrous female whose old skin had broken away from her lips and head and stood out around her neck like a Queen Anne collar, and who started gliding away at our approach, and whose consort, lying patiently by her side, ignored our presence, and gaping his fearful mouth, seized her gently about the middle and detained her. That, I believe, we can all understand.

And I also know that the problems presented by the Snake Key moccasins are fundamental ones which, for personal and biological interest, would more than justify the time spent in their solution.

ANNOTATED LIST OF THE BIRDS OF ALACHUA COUNTY, FLORIDA

ROBERT C. McCLANAHAN
Pensacola High School

EVERY ornithologist visiting a new territory longs for a summary of the findings of previous workers; this paper attempts to provide that help for future bird students in Alachua County. In addition, the presentation of present knowledge always brings attention to points that need further investigation, and that too is the purpose of this list.

Material for this paper is taken from publications of Oscar E. Baynard, Dr. Frank M. Chapman, Arthur H. Howell, and Harry C. Oberholser. Also specimens in the Department of Biology, University of Florida, have been examined, and the records of the Florida State Museum have been copied and used, but specimens were not examined because of inadequate storage and cataloguing methods. Another important source of information was correspondence with Mr. Baynard and conversation and correspondence with Charles E. Doe. Except for nesting data, which is taken almost wholly from Baynard's paper, the majority of the material is taken from my own notes covering a period of four years, 1930-34.

Most of Mr. Baynard's work was done in the vicinity of Orange Lake. The territory covered by Frank M. Chapman was probably only the vicinity of Gainesville. Places most frequently visited by the author were Payne's Prairie and its arms, Lake Wauberg, Orange Lake, Lake Newman, Sugarfoot Prairie, and the grounds of the Agricultural Experiment Station, which adjoins the University of Florida campus.

One point of particular inadequacy is the departure data for fall; the author never arrived in Gainesville until late September, and many species had evidently departed by that time. Migration dates given represent what the writer considers average unless otherwise stated. In all a total of two hundred and one species and subspecies is recorded, while one hundred and sixty-one of these have been recorded by the author.

1. COMMON LOON—*Gavia immer immer*. Rare migrant. Records are as follows: Chapman, fifteen from March 31 to April 17, 1887; Florida State Museum, specimen #45615 on June 1, 1929; one group seen by myself during the spring of 1932; and one captured alive November 21, 1935, specimen now in the Charles E. Doe Collection. Loons have also been seen by Oscar E. Baynard.

2. HORNED GREBE—*Colymbus auritus*. Occasional in winter. L. C. Remsen of McIntosh reports this species as occurring on Orange Lake, and it is reported by Baynard also.

3. PIED-BILLED GREBE—*Podilymbus podiceps podiceps*. Permanent resident, com-

mon in winter, but rare from April 1 until about September. This bird is widely distributed in all water areas. Nesting is substantiated by Baynard, who gives June 1 as the date.

4. FLORIDA CORMORANT—*Phalacrocorax auritus floridanus*. Permanent resident, common; generally distributed over all water areas. According to Baynard, nests rarely about April 10.

5. WATER-TURKEY—*Anhinga anhinga*. Permanent resident, common, being found on all bodies of water. Breeds from March through May.

6. GREAT WHITE HERON—*Ardea occidentalis*. This species is known only from a sight record by O. C. VanHyning on May 9, 1926 (Howell, p. 96).

7. GREAT BLUE HERON—*Ardea herodias herodias*. Winter resident, exact status unknown. One specimen mentioned by Oberholser, but no data given.

8. WARD'S HERON—*Ardea herodias wardi*. Permanent resident, common; may be seen on practically all bodies of water. Breeds in colonies during February and March; birds were building nests February 3, 1934, in a colony located on Bivan's Arm of Payne's Prairie.

9. AMERICAN EGRET—*Casmerodius albus egretta*.—Permanent resident, common; seen on all bodies of water. Breeds in April and May; found nesting at Bird Island and Orange Lake, where it was less common than the Snowy Egret.

10. SNOWY EGRET—*Egretta thula thula*. Permanent resident, not common during fall and winter, but apparently outnumbers the American Egret during the breeding season. Breeds from late March through early part of May; colonies at Bird Island and Bivan's Arm, and formerly (through 1934) just east of Lake Alice.

11. REDDISH EGRET—*Dichromanassa rufescens rufescens*. Baynard records the Reddish Egret as breeding on Orange Lake during 1907, 1908, and 1911; probably has not occurred since.

12. LOUISIANA HERON—*Hydranassa tricolor ruficollis*. Permanent resident, common; generally distributed, but never as numerous as the Snowy and American Egrets and Little Blue Heron. Breeds from middle March through May; colonies at Bird Island, Bivan's Arm, and formerly near Lake Alice.

13. LITTLE BLUE HERON—*Florida caerulea caerulea*. Permanent resident, common about all water. Breeds from about middle of March to middle of May; found nesting at Bird Island and formerly at Lake Alice.

14. EASTERN GREEN HERON—*Butorides virescens virescens*. Permanent resident, common in summer, but rare from middle of October until March. Breeds in April and May.

15. BLACK-CROWNED NIGHT HERON—*Nycticorax nycticorax hoactli*. Permanent resident, locally common. Seen at Bird Island regularly, but a preference is shown for small ponds and shaded "sinks." Breeds in March and April.

16. YELLOW-CROWNED NIGHT HERON—*Nyctanassa violacea violacea*. Permanent resident, uncommon. Reported by Baynard at Orange Lake; in my experience it prefers small ponds. Breeds in March and April.

17. AMERICAN BITTERN—*Botaurus lentiginosus*. Permanent resident, rare in breeding season, but common during the winter in all marshes. Baynard reports eggs on June 15.

18. EASTERN LEAST BITTERN—*Ixobrychus exilis exilis*. All records of my own, as well as published records of others, indicate that this species occurs only during the breeding season. Nests in marshes commonly from April through May.

19. WOOD IBIS—*Mycteria americana*. Common after nesting season, but I have no winter or early spring records. I found this species common on Payne's Prairie in July, 1936, but previously thought it rare. Nests in March and April.

20. EASTERN GLOSSY IBIS—*Plegadis falcinellus falcinellus*. Baynard found this bird breeding on Bird Island in 1909, April 1 to May 1. It has nested at Orange Lake in recent years, and at Bivan's Arm in 1936.

21. WHITE IBIS—*Guara alba*. Summer resident, common. On May 12, 1934, I estimated 5000 birds breeding on Bird Island; nests normally from April through May, but on July 13, 1936, I found two hundred pair nesting at Bivan's Arm, some still having eggs. This was the first time White Ibis has nested here, and the first nests were not built until sometime in June according to Charles E. Doe.

22. ROSEATE SPOONBILL—*Ajaia ajaja*. Chapman reports one observed by a Mr. Reynolds on April 23, 1887, and another in the collection of a Mr. Bell.

23. LESSER SNOW GOOSE—*Chen hyperborea hyperborea*. Rare, in late fall and winter. A specimen labelled *Chen h. nivalis*, #35739, in the Florida State Museum, is undoubtedly this form, although I have not examined the specimen. It was taken by T. A. Ridgell, November 24, 1927, on Payne's Prairie. Baynard has one or more additional records.

24. COMMON MALLARD—*Anas platyrhynchos platyrhynchos*. Winter resident, rare. Scattered records from middle November through February. No migration records for ducks are given as my records are not complete enough for accurate predictions; however, the middle of October finds many species already present, while the majority have departed by the middle of April in the spring.

25. RED-LEGGED BLACK DUCK—*Anas rubripes rubripes*. Winter resident, rare. The only records are by Chapman in 1887, when he reported it not uncommon.

26. FLORIDA DUCK—*Anas fulvigula fulvigula*. Permanent resident, common. Unknown until 1906, when it appeared on Payne's Prairie and began to nest (Baynard). Nests in April and May.

27. GADWALL—*Chaulelasmus streperus*. Winter resident, rare. I saw two live birds which L. C. Remsen had "winged" during the winter of 1933-34; also reported by Baynard.

28. EUROPEAN WIDGEON—*Mareca penelope*. The only record is a specimen taken at Orange Lake, December 26, 1931, by Dr. A. L. Strange. The specimen is in the collection of the Department of Biology, University of Florida.

29. BALDPATE—*Mareca americana*. Winter resident, common. Prefers larger lakes; most common on Orange Lake.

30. AMERICAN PINTAIL—*Dafila acuta tzitzihoa*. Winter resident, usually common. Duck hunters inform me that a fluctuation in numbers is common; some winters a species may be the predominant form, but during other winters few will be seen.

31. GREEN-WINGED TEAL—*Nettion carolinense*. Winter resident, rare. I saw a captive bird taken by L. C. Remsen in 1933 on Orange Lake. Reported common by Chapman and also seen by Baynard.

32. BLUE-WINGED TEAL—*Querquedula discors*. Winter resident, common.

33. SHOVELLER—*Spatula clypeata*. Winter resident, usually considered rare, but in my experience, common, especially at Bivan's Arm.

34. WOOD DUCK—*Aix sponsa*. Permanent resident, common. Prefers cypress swamps about lakes and small wooded ponds. Breeds in cavities in trees in April and May.

35. RING-NECKED DUCK—*Nyroca collaris*. Winter resident, usually the most common duck, but showing a decrease in recent winters.

36. CANVASBACK—*Nyroca valisineria*. Winter resident, rare. A specimen (#35934) in the Florida State Museum was collected December 13, 1927, by G. E. Geller. Not seen by Chapman or myself, but reported by Baynard.

37. RUFFLE-HEAD—*Charitonetta albeola*. Winter resident, rare. I examined a specimen taken on Orange Lake in December, 1933; also reported by Baynard.

38. RUDDY DUCK—*Erismatura jamaicensis rubida*. Winter resident, uncommon. Occurs only in small flocks, mainly on open bodies of water.

39. HOODED MERGANSER—*Lophodytes cucullatus*. Winter resident, rare. Reported by Chapman and Baynard; also seen on Orange Lake by hunters.

40. RED-BREASTED MERGANSER—*Mergus serrator*. Rare winter visitant. The only record is a specimen (#50708) in the Florida State Museum, taken November 30, 1931, by Paul Winter.

41. TURKEY VULTURE—*Cathartes aura septentrionalis*. Permanent resident, abundant. Occurs singly more often than in flocks; always present on Payne's Prairie. Breeds from March through May.

42. BLACK VULTURE—*Coragyps atratus atratus*. Permanent resident, abundant. In flocks more often than singly; likewise common on Payne's Prairie. Breeds from February to June.

43. SWALLOW-TAILED KITE—*Elanoides forficatus forficatus*. Rare migrant. Five observed by Chapman, the only record.

44. MISSISSIPPI KITE—*Ictinia mississippiensis*. Three records; Chapman, April 29, 1887, and one seen by the writer one mile west of Gainesville on May 18, 1934. Also reported by Baynard.

45. SHARP-SHINNED HAWK—*Accipiter velox velox*. Common in winter, but rare as a breeding bird. Nests April 15 to May 1.

46. COOPER'S HAWK—*Accipiter cooperi*. Not as common as the Sharp-shinned Hawk in winter, but breeds more commonly. Nests in March and April.

47. EASTERN RED-TAILED HAWK—*Buteo borealis borealis*. Permanent resident, common. All specimens in the Florida State Museum are catalogued as *Buteo borealis borealis* Nests in March.

48. FLORIDA RED-TAILED HAWK—*Buteo borealis umbrinus*. A specimen brought to the Florida State Museum, December 27, 1933, was identified by Charles E. Doe as this form. It is quite likely that intermediates are common in this locality, although A. H. Howell (Florida Bird Life) says that *Buteo b. borealis* "probably breeds south to Gainesville."

49. FLORIDA RED-SHOULDERED HAWK—*Buteo lineatus alleni*. Permanent resident, common. Typical *Buteo lineatus alleni* are more common, but one taken by Dr. H. B. Sherman on January 7, 1928, was identified by the U. S. Biological Survey as being nearer *Buteo lineatus lineatus*, but not quite typical; this is interesting in view of the fact that the typical northern form has never been recorded from the state, and also since Dr. Josselyn VanTyne identified this specimen as typical *Buteo lineatus lineatus*. The specimen is #26 in the Department of Biology Collection at the University of Florida. Breeds from middle of February to April.

50. BROAD-WINGED HAWK—*Buteo platypterus platypterus*. Rare; arrives sometime in April and breeds in May.

51. SHORT-TAILED HAWK—*Buteo brachyurus*. One record, a specimen (#28639) in the Florida State Museum, collected by O. C. VanHyning, February 27, 1926.

52. SOUTHERN BALD EAGLE—*Haliaeetus leucocephalus leucocephalus*. Permanent resident, common. Frequents lakes where it often robs the Osprey of its fish. There has been a noticeable decrease in the numbers of this bird in the past six years. Lays in December.

53. MARSH HAWK—*Circus hudsonius*. Permanent resident, rare in breeding season, but common at other times. Although most common over prairies, such as Payne's Prairie, it is often seen over dry fields. Most birds seen are either females or immature males. Baynard reports it breeding at Micanopy in May and June.

54. OSPREY—*Pandion haliaetus carolinensis*. Permanent resident, rare in December and January, but common during remainder of year. Nests from February through May.

55. DUCK HAWK—*Falco peregrinus anatum*. Winter resident, rare. Reported by Baynard, while I have three records as follows: Payne's Prairie, January 9, 1931; University of Florida campus, February, 1931; and January 12, 1934, about one mile west of Gainesville.

56. EASTERN PIGEON HAWK—*Falco columbarius columbarius*. Winter resident, rare. Reported by Baynard, and a single specimen was collected by Chapman on January 4, 1887.

57. LITTLE SPARROW HAWK—*Falco sparverius paulus*. Permanent resident, common. Nests on the University of Florida campus; eggs most common about middle of April. Charles E. Doe states by letter that he suspects *Falco s. sparverius* also occurs in winter, but all winter specimens I have examined were *Falco sparverius paulus*.

58. BOBWHITE—*Colinus virginianus*. Permanent resident, common. The Bobwhite is much more common in Alachua County than in Escambia County, where I have observed it for over ten years. According to Howell (p. 193), two specimens from Gainesville are intermediate between *Colinus v. virginianus* and *Colinus virginianus floridanus*. Breeds from April to September.

59. FLORIDA TURKEY—*Meleagris gallopavo osceola*. Permanent resident, rare. Howell (p. 195) states that birds of this region are not typical, but are nearer *osceola*. Baynard reports full sets of eggs on April 15.

60. FLORIDA CRANE—*Grus canadensis pratensis*. Rare; I have not seen this species. Baynard reports that it once bred on the prairies of two lakes; nests in April.

61. LIMPKIN—*Aramus pictus pictus*. Rare; I have not seen this species within the county, but recorded it on the Ocklawaha River in Marion County. Baynard reports it breeding from November to June, with the height of the nesting season in April and May.

62. KING RAIL—*Rallus elegans elegans*. Permanent resident, not uncommon, but not often seen because of its secretiveness, a characteristic of all rails. Nests in May.

63. VIRGINIA RAIL—*Rallus limicola limicola*. Winter resident, rare. The only observation is by Baynard, who by letter informs me of two birds on Payne's Prairie either December 9 or 10, 1934.

64. SORA—*Porzana carolina*. Winter resident, rare. Recorded by Baynard, Chapman, and F. W. Walker (specimen #9, Department of Biology, University of Florida).

65. BLACK RAIL—*Creciscus jamaicensis stoddardi*. Rare; the only record is by Baynard, who saw an adult with three young in early June.

66. PURPLE GALLINULE—*Ionornis martinica*. Common during nesting season, and probably winters rarely, but I have no records of its doing so. Prefers water areas with a bonnet or water-hyacinth growth. Nests March to August.

67. FLORIDA GALLINULE—*Gallinula chloropus cachinnans*. Permanent resident, common. Habitat water in which there is a growth of bonnets or hyacinth. Nests March to July.

68. AMERICAN COOT—*Fulica americana americana*. Abundant during winter, probably remaining to breed rarely. Baynard has killed females full of eggs in June.

69. KILLDEER—*Oxyechus vociferus vociferus*. Permanent resident, but less common during nesting season. Found about all open ponds and lakes. Nests in April and May.

70. AMERICAN WOODCOCK—*Philohela minor*. Permanent resident, rare. Reported nesting on February 4 by Baynard.

71. WILSON'S SNIFE—*Capella delicata delicata*. Winter resident, common. Arrives October 1 and departs April 15. Occurs about the edge of all ponds and lakes.

72. UPLAND PLOVER—*Bartramia longicauda*. Rare migrant. Chapman saw it on two occasions, April 8 and 10, 1887; also recorded by Baynard.

73. SPOTTED SANDPIPER—*Actitis macularia*. Common migrant. In spring arrives April 22 and departs May 12; no data available on fall migration.

74. EASTERN SOLITARY SANDPIPER—*Tringa solitaria solitaria*. Common migrant. Usual spring arrival, April 5, and departure May 6; no data on fall migration.

75. GREATER YELLOW-LEGS—*Totanus melanoleucus*. Rare migrant. I saw one bird on April 15, 1934, while George VanHynning reported seeing several a few days earlier; also reported by Baynard.

76. LESSER YELLOW-LEGS—*Totanus flavipes*. Uncertain migrant. Earliest arrival, February 22; departure about April 5; no records for fall.

77. LEAST SANDPIPER—*Pisobia minutilla*. Not uncommon winter resident; most common in spring migration. Departs in spring about May 12; no data on fall arrival.

78. HERRING GULL—*Larus argentatus smithsonianus*. Winter resident; rare. Seen on only one occasion, December 17, 1931, on Lake Newnan, where they were common for this day. Also reported by Baynard.

79. RING-BILLED GULL—*Larus delawarensis*. Winter resident, not uncommon. Last seen April 22; no arrival data available. Occurs about water, even small ponds.

80. FORSTER'S TERN—*Sterna forsteri*. Not seen by myself, but recorded by Baynard, and also Howell (p. 262) at Orange Lake, May 25, 1929.

81. EASTERN SOOTY TERN—*Sterna fuscata fuscata*. Accidental. After a hurricane in September, 1928, large numbers appeared over Gainesville, and specimens (#'s 39216-39218) were brought to the Florida State Museum on September 19 and 20.

82. EASTERN MOURNING DOVE—*Zenaidura macroura carolinensis*. Permanent resident, common. Much more numerous in winter. Nests in May.

83. EASTERN GROUND DOVE—*Columbigallina passerina passerina*. Permanent resident, common. Nests during every month of the year except December and January.

84. PASSENGER PIGEON—*Ectopistes migratorius*. Now extinct. Listed by Chapman as a rare winter visitant in 1887, with two specimens in the possession of a Mr. Reynolds.

85. YELLOW-BILLED CUCKOO—*Coccyzus americanus americanus*. Summer resident, common. Arrives about April 4 and departs October 27. Nests April to August.

86. BLACK-BILLED CUCKOO—*Coccyzus erythrophthalmus*. The only record is by Baynard; three were positively identified on May 11, 1935, at Gainesville, and two at High Springs on May 12, 1935. Others seen on May 11 were probably of this species.

87. BARN OWL—*Tyto alba pratincola*. Permanent resident, rare. I have not seen this species, but it has been recorded by Chapman and Baynard, and there is a specimen in the Florida State Museum (#4004). Nests in November.

88. FLORIDA SCREECH OWL—*Otus asio floridanus*. Permanent resident, not common. Nests in April.

89. GREAT HORNED OWL—*Bubo virginianus virginianus*. Permanent resident, rare. Nests in January.

90. FLORIDA BARRED OWL—*Strix varia alleni*. Permanent resident, common. This owl may be expected in any wooded place. Nests in January.

91. CHUCK-WILLS WIDOW—*Antrostomus carolinensis*. Summer resident, common. Arrives March 28; no departure record available. Nests in April and May.

92. EASTERN WHIP-POOR-WILL—*Antrostomus vociferus vociferus*. Winter resident, rare. Not seen by the author, but reported by Baynard, Chapman, Dr. H. B. Sherman, and specimens in the Florida State Museum. Records from November 23 to March 13.

93. FLORIDA NIGHTHAWK—*Chordeiles minor chapmani*. Summer resident, common. Arrives about April 14 and departs in first part of October. Nests in April and May.

94. CHIMNEY SWIFT—*Chaetura pelagica*. Summer resident, common. Arrives first part of April and departs first of November. Nests from May to June.

95. RUBY-THROATED HUMMINGBIRD—*Archilochus colubris*. Common in fall and spring migrations, and a few remain to breed. Arrives in March; no departure date available. Nests in May and June.

96. EASTERN BELTED KINGFISHER—*Megaceryle alcyon alcyon*. Permanent resident; common in winter, but only a few remain to breed. Nests in April.

97. SOUTHERN FLICKER—*Colaptes auratus auratus*. Permanent resident, common. Nests March to June.

98. SOUTHERN PILEATED WOODPECKER—*Ceophloeus pileatus pileatus*. Permanent resident, common. Nests in April.

99. RED-BELLIED WOODPECKER—*Centurus carolinus*. Permanent resident, common. Nests April to June.

100. RED-HEADED WOODPECKER—*Melanerpes erythrocephalus*. Permanent resident, becoming less common in winter. Nests from May through June.

101. YELLOW-BELLIED SAPSUCKER—*Sphyrapicus varius varius*. Winter resident, common. Arrives October 11 and departs March 21.

102. SOUTHERN HAIRY WOODPECKER—*Dryobates villosus auduboni*. Permanent resident, uncommon. Nests in April and May.

103. SOUTHERN DOWNY WOODPECKER—*Dryobates pubescens pubescens*. Permanent resident, common. Nests in May.

104. RED-COCKADED WOODPECKER—*Dryobates borealis*. Permanent resident, uncommon. Occurs only in piney woods. Nests in May.

105. IVORY-BILLED WOODPECKER—*Campephilus principalis*. Probably extinct now; found breeding by Baynard, with no date given, but probably since 1904.

106. EASTERN KINGBIRD—*Tyrannus tyrannus*. Summer resident, common. Arrives April 4; no departure available. Nests in May.

107. SOUTHERN CRESTED FLYCATCHER—*Myiarchus crinitus crinitus*. Summer resident, common. Arrives March 31; no departure date available. Nests in May.

108. EASTERN PHOEBE—*Sayornis phoebe*. Winter resident, common. Arrival, October 5; departure, April 4.

109. ACADIAN FLYCATCHER—*Empidonax virescens*. Rare migrant. Seen in September, 1931; arrival in spring given as April 20 by Chapman.

110. EASTERN WOOD PEWEE—*Myiochanes virens*. Summer resident, rare. Arrives April 7; no departure available. Nests in early June.

111. TREE SWALLOW—*Iridoprocne bicolor*. Winter resident, common. Arrival, October 15; departure, May 1.

112. ROUGH-WINGED SWALLOW—*Stelgidopteryx ruficollis serripennis*. Exact status not known; seen by Baynard and Charles E. Doe.

113. BARN SWALLOW—*Hirundo erythrogaster*. Common migrant in both spring and fall. In fall migrates in October; common from April 6 to May 9 in spring.

114. NORTHERN CLIFF SWALLOW—*Petrochelidon albifrons albifrons*. Migrant; one record by the author at Payne's Prairie, October 27, 1933, verified by a report from Charles E. Doe that he saw them at about the same time.

115. PURPLE MARTIN—*Progne subis subis*. Summer resident, common. Arrival, February 9; departure, September 27. Nests in April and May.

116. FLORIDA BLUE JAY—*Cyanocitta cristata florincola*. Permanent resident, common. Nests March to July.

117. FLORIDA JAY—*Aphelocoma coerulescens*. The only record by Baynard; nested once on April 16.

118. FLORIDA CROW—*Corvus brachyrhynchos pascuus*. Permanent, resident, not common. Nests March to April.

119. FISH CROW—*Corvus ossifragus*. Permanent resident, common. Nests in April.

120. FLORIDA CHICKADEE—*Penthestes carolinensis impiger*. Permanent resident, common. Nests February to June.

121. TUFTED TITMOUSE—*Baeolophus bicolor*. Permanent resident, common. Nests February to April.

122. FLORIDA NUTHATCH—*Sitta carolinensis atkinsi*. Permanent resident, rare. I have never seen this species; reported by Chapman, and found breeding by Baynard in March.

123. GRAY-HEADED NUTHATCH—*Sitta pusilla caniceps*. Permanent resident, common. Found only in pine woods. Nests February to May.

124. BROWN CREEPER—*Certhia familiaris americana*. Winter resident, rare. The only record is a specimen in the Florida State Museum taken March 18, 1930 by C. F. Aschemeier (#47030).

125. EASTERN HOUSE WREN—*Troglodytes aedon aedon*. Winter resident, common. Arrives October 12; departs April 30.

126. EASTERN WINTER WREN—*Nannus hiemalis hiemalis*. Winter resident, rare. Earliest fall record, November 10; latest in spring, March 6 (Dr. H. B. Sherman).

127. BEWICK'S WREN—*Thryomanes bewicki bewicki*. Winter resident, rare. Earliest fall record, September 20, 1919, collected by F. W. Walker (specimen #67, Department of Biology, University of Florida); latest spring record, February 4.

128. FLORIDA WREN—*Thryothorus ludovicianus miamensis*. Permanent resident, common. Nests March to July.

129. EASTERN MOCKINGBIRD—*Mimus polyglottos polyglottos*. Permanent resident, common. Nests March to August.

130. CATBIRD—*Dumetella carolinensis*. Permanent resident, rare in winter and breeding season, but common in both migrations. Nests in April.

131. BROWN THRASHER—*Toxostoma rufum*. Permanent resident, common in winter, decreases by nesting period. Nests in April.

132. EASTERN ROBIN—*Turdus migratorius migratorius*. Winter resident, common. Southern Robin probably occurs also. Arrives in early November; usually leaves in early April.

133. WOOD THRUSH—*Hylocichla mustelina*. Migrant and winter resident, rare. One winter record, December 12, 1930. No significant data on migration.

134. EASTERN HERMIT THRUSH—*Hylocichla guttata faxoni*. Winter resident, common. Arrival, October 25; departure, April 15.

135. GRAY-CHEEKED THRUSH—*Hylocichla minima aliciae*. Rare migrant. One record, a specimen taken by Chapman, April 26, 1887.

136. EASTERN BLUEBIRD—*Sialia sialis sialis*. Permanent resident, common. Nests March to June.

137. BLUE-GRAY GNATCATCHER—*Poliophtila caerulea caerulea*. Permanent resident, common. Nests in April.

138. EASTERN GOLDEN-CROWNED KINGLET—*Regulus satrapa satrapa*. Winter resident, rare. Recorded by Baynard, and two specimens (#'s 45723 and 46829) in the Florida State Museum taken November 30, 1929.

139. EASTERN RUBY-CROWNED KINGLET—*Corthylio calendula calendula*. Winter resident, common. Arrival, October 17; departure, April 24.

140. AMERICAN PIPIT—*Anthus spinoletta rubescens*. Winter resident, common. Arrival, November 10; departure, April 12.

141. CEDAR WAXWING—*Bombycilla cedrorum*. Winter resident; occurs in large numbers from March to May, but rare in winter. Departure, May 6.

142. LOGGERHEAD SHRIKE—*Lanius ludovicianus ludovicianus*. Permanent resident, common. Nests February to July.

143. WHITE-EYED VIREO—*Vireo griseus griseus*. Permanent resident, rather rare in winter, but common at other times. Nests in April and May.

144. YELLOW-THROATED VIREO—*Vireo flavifrons*. Common migrant; perhaps nests rarely; a very late departure of November 12 was obtained; arrival, April 6.

145. BLUE-HEADED VIREO—*Vireo solitarius solitarius*. Winter resident, not uncommon. Chapman secured specimens of this and the following subspecies and found them occurring in about equal numbers. Arrival, middle of November; departure, March 26.

146. MOUNTAIN VIREO—*Vireo solitarius alticola*. Winter resident, uncommon. Migration dates of the former subspecies apply, as it is impossible to separate the two in the field.

147. RED-EYED VIREO—*Vireo olivaceus*. Summer resident, common. Arrival, March 27; departure, October 15. Nests in early May.

148. BLACK AND WHITE WARBLER—*Mniotilta varia*. Winter resident, common. Arrival, probably in August; departure, April 26.

149. PROTHONOTARY WARBLER—*Protonotaria citrea*. Migrant and summer resident, uncommon. Arrival, April 1; departure data not available, but probably early September. No nesting records, but nest found in Marion County on May 16.

150. WORM-EATING WARBLER—*Helmitheros vermivorus*. Rare migrant, and accidental in winter. Chapman took two specimens, April 11 and December 26, 1887; also recorded by Baynard.

151. ORANGE-CROWNED WARBLER—*Vermivora celata celata*. Winter resident, not uncommon. Arrival, October 28; departure, April 1.

152. NORTHERN PARULA WARBLER—*Compsothlypis americana pusilla*. Migrant only; Howell (p. 394) mentions specimens taken at Gainesville, October 5, 6, and 21, 1919.

153. SOUTHERN PARULA WARBLER—*Compsothlypis americana americana*. Summer resident, common. Arrival, March 5; departure, unusually late birds seen on November 19. Nests in early April.

154. EASTERN YELLOW WARBLER—*Dendroica aestiva aestiva*. Uncommon migrant. Arrival in spring, April 15; arrival in fall, July 24. No departure data available.

155. CAPE MAY WARBLER—*Dendroica tigrina*. Rare migrant in spring; arrival about April 15.

156. BLACK-THROATED BLUE WARBLER—*Dendroica caerulescens caerulescens*. Rare migrant; arrival about April 10, remaining until early May. Probably occurs in fall.

157. MYRTLE WARBLER—*Dendroica coronata*. Winter resident, common. Arrival, November 7; departure, April 20.

158. YELLOW-THROATED WARBLER—*Dendroica dominica dominica*. Permanent resident, common. Not listed by Baynard as nesting, but it remains throughout the summer and certainly nests.

159. BLACK-POLL WARBLER—*Dendroica striata*. Uncommon migrant; appears in May.

160. NORTHERN PINE WARBLER—*Dendroica pinus pinus*. Permanent resident, common. Nests in March.

161. KIRTLAND'S WARBLER—*Dendroica kirtlandi*. Rare migrant. One record, a bird observed at Bivan's Arm, April 26, 1934.

162. NORTHERN PRAIRIE WARBLER—*Dendroica discolor discolor*. Migrant; recorded by Howell (p. 407).

163. FLORIDA PRAIRIE WARBLER—*Dendroica discolor collinsi*. Uncommon summer resident. Nests in late April. Migrant birds, which are common during the first two weeks of April, may be *Dendroica d. discolor*.

164. WESTERN PALM WARBLER—*Dendroica palmarum palmarum*. Winter resident, common. Arrival, October 15; departure, April 25.

165. YELLOW PALM WARBLER—*Dendroica palmarum hypochrysea*. Winter resident, not uncommon. Arrives later and leaves earlier than the Western Palm Warbler.

166. OVENBIRD—*Seiurus aurocapillus*. Winter resident, not uncommon. Arrival, October; departure, April 19.

167. GRINNEL'S WATER-THRUSH—*Seiurus noveboracensis notabilis*. One record, a specimen (#36861) in the Florida State Museum, taken by O. C. Van Hyning on May 13, 1928.

168. LOUISIANA WATER-THRUSH—*Seiurus motacilla*. Migrant in spring and fall. In spring, during March and April; seen on October 27 in fall.

169. NORTHERN YELLOWTHROAT—*Geothlypis trichas brachidactyla*. Howell (p. 417) records a specimen taken February 13, 1890.

170. FLORIDA YELLOWTHROAT—*Geothlypis trichas ignota*. Permanent resident, common. Nests in late April and May.

171. HOODED WARBLER—*Wilsonia citrina*. Migrant in spring and fall. More common in April during spring; in fall during September and October.

172. AMERICAN REDSTART—*Setophaga ruticilla*. Common migrant in both spring and fall. In spring from March 28 to May 8; in fall during October.

173. ENGLISH SPARROW—*Passer domesticus domesticus*. Permanent resident, abundant.

174. BOBOLINK—*Dolichonyx oryzivorus*. Common migrant in spring; April 19 to May 13. Chapman reports one on January 5, 1887.

175. SOUTHERN MEADOWLARK—*Sturnella magna argutula*. Permanent resident, common. Nests in late April.

176. FLORIDA RED-WING—*Agelaius phoeniceus mearnsi*. Permanent resident, common. Nests March to July.
177. ORCHARD ORIOLE—*Icterus spurius*. Rare breeder, and uncommon migrant. Arrival, April 13; probably departs in August. Nests in early June.
178. BALTIMORE ORIOLE—*Icterus galbula*. Chapman reports two wintering birds, December 15, 1886, and February 4, 1887.
179. RUSTY BLACKBIRD—*Euphagus carolinus*. Winter resident, irregular. Arrival, not known; departure March 20.
180. WESTON'S GRACKLE—*Cassidix mexicanus westoni*. Permanent resident, common. Nests from March to July.
181. FLORIDA GRACKLE—*Quiscalus quiscula aglaeus*. Permanent resident, common. Nests in April and May.
182. EASTERN COWBIRD—*Molothrus ater ater*. Winter resident, irregular. Arrival, November 13; departure, sometime in March.
183. SUMMER TANAGER—*Piranga rubra rubra*. Summer resident, common. Arrival, April 12; departure, late September. Nests in early May.
184. FLORIDA CARDINAL—*Richmondia cardinalis floridana*. Permanent resident, common. Nests from April to September.
185. INDIGO BUNTING—*Passerina cyanea*. Uncommon, Chapman reports a female on January 27, 1887; and saw several from October 16 through 21, 1933. H. H. Bailey reports a nest found at Gainesville (Howell).
186. EASTERN PURPLE FINCH—*Carpodacus purpureus purpureus*. Winter resident. Chapman reports them "not uncommon." I have not seen this species.
186. NORTHERN PINE SISKIN—*Spinus pinus pinus*. Winter visitor. Howell (page 445) states that Brewster and Chapman recorded one bird at Gainesville on February 15, 1890.
188. EASTERN GOLDFINCH—*Spinus tristis tristis*. Winter resident, common. Arrival, November 19; departure, April 14.
189. RED-EYED TOWHEE—*Pipilo erythrophthalmus erythrophthalmus*. Winter resident, common. Arrives in October; departs in April.
190. WHITE-EYED TOWHEE—*Pipilo erythrophthalmus alleni*. Permanent resident, common. Nests from April through June.
191. EASTERN SAVANNAH SPARROW—*Passerculus sandwichensis savanna*. Winter resident, common. Arrival, October 15; departure, April 15.
192. FLORIDA GRASSHOPPER SPARROW—*Ammodramus savannarum floridanus*. Permanent resident, rare. Probably nests in May.
193. SHARP-TAILED SPARROW—*Ammodramus caudacuta caudacuta*. Known from six specimens in the Florida State Museum; taken by C. F. Aschemeier from December 2, 1930, through January 6, 1931.
194. EASTERN VESPER SPARROW—*Pooecetes gramineus gramineus*. Winter resident, common. Arrival, October 27; departure April 1.
195. BACHMAN'S SPARROW—*Aimophila aestivalis bachmani*. Winter resident, not uncommon. No migration data available, since few specimens were taken.
196. PINE-WOODS SPARROW—*Aimophila aestivalis aestivalis*. Summer resident, common; probably occurs in winter also. Nests in April.
197. EASTERN CHIPPING SPARROW—*Spizella passerina passerina*. Winter resident, common. Arrival October 18; departure, April 8.

198. EASTERN FIELD SPARROW—*Spizella pusilla pusilla*. Winter resident, irregular. Arrival in December; departure, April 8.

199. WHITE-THROATED SPARROW—*Zonotrichia albicollis*. Winter resident, common. Arrival, November 5; departure, last of April.

200. SWAMP SPARROW—*Melospiza georgiana*. Winter resident, common. Arrival, November 5; departure, April 10.

201. EASTERN SONG SPARROW—*Melospiza melodia melodia*. Winter resident, not uncommon. Arrival, November 1; departure March 20.

LIST OF THE RECENT WILD LAND MAMMALS OF FLORIDA

H. B. SHERMAN
University of Florida

NO RECENT list of the land mammals of this region, intended to be complete, has appeared since the publication in 1898 of "Land Mammals of Peninsular Florida and the Coast Region of Georgia" by Bangs. Many of the names used by Bangs are now synonyms and a number of new forms have been described in the past thirty nine years. It is the purpose of the present paper to list, under the scientific names now in use, the land mammals of the state, cite the more important literature, and furnish information as to the geographical distribution of each form.

For unpublished distribution records for certain species of bats, I am indebted to the U. S. Biological Survey, U. S. National Museum, Academy of Natural Sciences of Philadelphia, Field Museum of Natural History, Chicago Academy of Sciences, Dr. W. J. Hamilton of Cornell University, and Dr. E. V. Komarek of the Cooperative Quail Study Association of Thomasville, Georgia. Also I am indebted to W. Frank Blair for adding unpublished records from his collection (WFB) and from the collection of the University of Michigan Museum of Zoölogy (UM). As in the above two cases my records are indicated by initials.

The majority of our mammals belong to groups which have been revised fairly recently, for which reason their relationships and geographical ranges are generally well known. With members of certain other groups, for example the short-tailed shrews and the salamanders (*Geomys*), it seems probable that a modern revision will alter considerably our present ideas of their taxonomy. Also certain regions of the state have been favorite collecting grounds while others have been neglected. Much field work remains to be done to determine the details of distribution in these little-worked areas.

Eighty-four species or subspecies are here listed of which six have

been introduced and five others of which are known only from single locality records. Recently attempts have been made to introduce the beaver and muskrat, but these are not listed, as the success of these experiments is problematical.

History.—Exclusive of the writings of the early explorers, in which many statements are present concerning the larger or more conspicuous mammals, the earliest list of Florida mammals which I have seen is that of J. A. Allen, 1871, which deals with the mammals of eastern Florida, chiefly from the region of the St. Johns River. Thirty-five species are discussed, one of which, the manatee, is aquatic.

The following year, Maynard's "Catalogue of the mammals of Florida, with notes on their habits, distribution, etc." appeared, which records the roof rat, a leaf-nosed bat, and a porpoise in addition to those mentioned by Allen. The same list was also published, with but few changes, in 1883.

In 1894, Rhoads' list of 22 species of mammals from the region of Tarpon Springs was published, which contains a description of 2 new species.

Also in 1894, Chapman's "Remarks on certain land mammals of Florida with a list of the species known to occur in the state" appeared. In this, 53 species and subspecies are discussed.

Cory's "Hunting and Fishing in Florida," 1896, contains much of interest concerning the habits of the larger mammals. He mentions 52 kinds of mammals as occurring in the state.

In 1898, Bangs' "Land mammals of peninsular Florida and the coast region of Georgia" was published, and is one of the most important technical papers dealing with the mammals of this region. Sixty-two Florida forms are discussed, a number of which are described for the first time.

Another article of interest in this connection is that of Elliot, 1901, which deals with the mammals collected in North and South Carolina, Georgia, and Florida.

More recently, Simpson, 1929, includes a list of the recent land mammals for comparison with the extinct land mammals of Florida. This is incomplete for certain groups were intentionally omitted, namely the bats and "those species or subspecies which are peculiar to islands or keys of Florida, or which may enter northern Florida."

Also an interesting non-technical account of "Florida's Mammals" by A. H. Howell, is in *Nature Magazine* for December, 1929.

The arrangement of species in the following list is the same as that adopted by Miller in his "List of the North American recent mammals, 1923" and in most cases the common names used are the same as those of Anthony's "Field book of North American mammals" 1928.

CLASS MAMMALIA

SUBCLASS EUTHERIA

ORDER MARSUPIALIA

FAMILY DIDELPHIIDAE

Genus *Didelphis* Linn.—Opossums

1901. J. A. Allen, A preliminary study of the North American opossums of the genus *Didelphis*. Bull. Amer. Mus. Nat. Hist., vol. 14, pp. 149-188.

Didelphis virginiana pigra Bangs.—Florida Opossum.

1898. *Didelphis virginiana pigra* Bangs, Proc. Bost. Soc. Nat. Hist., vol. 28, p. 172.

TYPE LOCALITY.—Oak Lodge, opposite Micco, Brevard County, Florida.

RANGE.—“Florida, the lower coast region of Georgia, and the low Gulf Coast belt as far as western Louisiana.” Miller, 1924, p. 3.

FLORIDA RECORDS:—Alachua County, Alachua, Gainesville, HBS; Brevard County, Oak Lodge, Eau Gallie, Bangs, 1898, p. 172; Citrus County, Deer Creek, Bangs, 1898, p. 172; 10 miles south of Inverness, HBS; Duval County, New Berlin, Bangs, 1898, p. 172; Lake County, Lake Norris, HBS; Monroe County, 5 miles east of Flamingo, Blair, 1935b, p. 802; St. Johns County, Anastasia Island, Elliot, 1901, p. 33; Volusia County, Enterprise, Elliot, 1901, p. 33.

ORDER INSECTIVORA

FAMILY TALPIDAE—MOLES

Genus *Scalopus* Geoffroy

1915. H. H. T. Jackson. A review of the American moles. N. Amer. Fauna #38, U. S. Dept. Agric., Bureau of Biological Survey.

Scalopus aquaticus howelli Jackson.—Howell's Mole.

1914. *Scalopus aquaticus howelli* Jackson, Proc. Biol. Soc. Washington, vol. 27, p. 19.

TYPE LOCALITY.—Autaugaville, Autauga County, Alabama.

RANGE.—“North Carolina (except in Appalachian Mountains), South Carolina, northern Georgia, thence southwest across central Alabama and southern Mississippi to Pensacola Bay and the Mississippi River.” Jackson, 1915, pp. 36-7.

FLORIDA RECORDS:—Escambia County, Pensacola, Jackson, 1915, p. 37; Liberty County, Rock Bluff, HBS.

Scalopus aquaticus australis (Chapman).—Florida Mole.

1893. *Scalops aquaticus australis* Chapman, Bull. Amer. Mus. Nat. Hist., vol. 5, p. 339.

TYPE LOCALITY.—Gainesville, Alachua County, Florida.

RANGE.—“Southeastern Georgia and the eastern portion of peninsular Florida south to Lemon City.” Jackson, 1915, p. 38.

FLORIDA RECORDS:—from Jackson, 1915, p. 39, unless otherwise stated; Alachua County, Gainesville, Micanopy, HBS; Levy Lake, UM; Brevard County, Canaveral, East Micco, Georgiana, Indian River, Oak Lodge; Dade County, Lemon City, southwest of Royal Palm State Park, H. H. Bailey, 1930; Duval County, Jacksonville, New Berlin; Lake County, Eustis; Marion County, Lynne; Palm Beach County, Lake Worth; St. Johns County, Point Matanzas, Bangs, 1898, p. 211, St. Augustine; Volusia County, Enterprise, Kissimmee River, Lake Harney, Orange Hammock.

Scalopus aquaticus anatasae (Bangs).—Anastasia Island Mole.

Scalops anatasae Bangs, Proc. Boston Soc. Nat. Hist., vol. 28, p. 212.

TYPE LOCALITY.—Point Romo, Anastasia Island, Florida.

RANGE.—“Anastasia Island, Florida.” Jackson, 1915, p. 39.

Scalopus aquaticus parvus (Rhoads).—Little Mole.

1894. *Scalops parvus* Rhoads, Proc. Acad. Nat. Sci. Philadelphia, p. 157.

TYPE LOCALITY.—Tarpon Springs, Pinellas County, Florida.

RANGE.—Region north of Tampa Bay, in Hillsboro, Pasco and Pinellas Counties, Fla.

FLORIDA RECORDS from Jackson, 1915, p. 42:—Hillsboro County, Port Tampa City; Pasco County, Port Richey; Pinellas County, Belleair, Seven Oaks, Tarpon Springs.

FAMILY SORICIDAE—SHREWS

Genus *Sorex* Linn.—Long-tailed Shrews

1928. H. H. T. Jackson, A taxonomic review of the American long-tailed shrews N. Amer. Fauna #51, U. S. Dept. Agric., Bureau Biol. Surv.

Sorex longirostris longirostris Bachman.—Bachman Shrew.

1837. *Sorex longirostris* Bachman, Journ. Acad. Nat. Sci. Philadelphia, vol. 7, pt. 2, p. 370.

TYPE LOCALITY.—Swamps of the Santee River, South Carolina.

RANGE.—“Atlantic plain and Piedmont region (except vicinity of Dismal Swamp, Va., inhabited by *S. l. fisheri*) from northern Virginia and southern Maryland, south to northern Florida (Alachua County) and central Alabama (Autauga County); eastern and southern Illinois and southwestern Indiana.” Jackson, 1928, p. 85.

FLORIDA RECORDS:—Alachua County, 5 miles east of Gainesville, Sherman, 1928, Blair, 1935a, p. 274.

Genus *Cryptotis* Pomel

Revised by Merriam under the name *Blarina*, 1895b. N. Amer. Fauna, #10, pp. 16–30. U. S. Dept. Agric., Bureau of Biol. Surv.

Cryptotis floridana (Merriam)—Florida Short-tailed Shrew.

1895. *Blarina floridana* Merriam, N. Amer. Fauna #10, p. 19.

TYPE LOCALITY.—Chester Shoal, 11 miles north of Cape Canaveral, Brevard County, Florida.

RANGE.—“Peninsular Florida, south of latitude 29°. Exact limits of range unknown.” Merriam, 1895b, p. 19. “Northward certainly to southeast Georgia (St. Mary’s).” Bangs, 1898, p. 209.

FLORIDA RECORDS:—Alachua County, Gainesville, HBS; Brevard County, Chester Shoal, 11 miles north of Cape Canaveral, Merriam, 1895b, p. 19; Indian River, Merriam, 1895b, p. 19, Micco, Merriam, 1895b, p. 19; Oak Lodge, Bangs, 1898, p. 209; Flager County, Carterville, Bangs, 1898, p. 209; St. Johns County, Point Matanzas, Bangs, 1898, p. 209; Volusia County, Enterprise, Elliot, 1901, p. 55.

Genus *Blarina* Gray

1895. C. Hart Merriam, Revision of the shrews of the genera *Blarina* and *Notiosorex*, N. Amer. Fauna 10, U. S. Dept. Agric., Bureau of Biol. Surv.

Blarina brevicauda carolinensis (Bachman)—Carolina Short-tailed Shrew.

1837. *Sorex carolinensis* Bachman, Journ. Acad. Nat. Sci. Philadelphia, vol. 7, pt. 2, p. 366.

TYPE LOCALITY.—Eastern South Carolina.

RANGE.—“From the mouth of Chesapeake Bay to Arkansas.” Merriam, 1895b, p. 13.

FLORIDA RECORDS:—Alachua County, Gainesville, HBS.

Blarina brevicauda peninsula (Merriam)—Everglade Short-tailed Shrew.

1895. *Blarina carolinensis peninsulae* Merriam, N. Amer. Fauna #10, p. 14.

TYPE LOCALITY.—Miami River, Dade County, Florida.

RANGE.—“Peninsula of Florida, south of latitude 28°.” Merriam, 1895b, p. 14.

FLORIDA RECORDS:—Brevard County, Micco, Merriam, 1895b, p. 15; Oak Lodge, Bangs, 1898, p. 208; Collier County, Everglade, Merriam, 1895b, p. 15; Dade County, Miami River, Merriam, 1895b, p. 15.

ORDER CHIROPTERA—BATS

FAMILY PHYLLOSTOMIDAE—AMERICAN LEAF-NOSED BATS

Genus *Artibeus* Leach

1908. Knud Andersen. A monograph of the chiropteran genera *Uroderma*, *Enchisthenes*, and *Artibeus*. Proc. Zool. Soc. London, pp. 204–319.

Artibeus jamaicensis subsp.

No Florida specimen is known to be in existence, but a drawing of a specimen obtained by C. J. Maynard at Key West in 1870, sent to Dr. Harrison Allen, 1893, pp. 52–53, led the latter to “unhesitatingly” identify it as *Artibeus perspicillatus*. Since *A. perspicillatus* is now a synonym of *A. jamaicensis* of which there are five subspecies, there is some doubt as to which one Maynard’s specimen should be assigned. The occurrence of *Artibeus jamaicensis parvipes* (Rhen) in Cuba suggests that this is the subspecies taken in Key West.

FAMILY VESPERTILIONIDAE

1897. Gerrit S. Miller, Jr. Revision of the North America bats of the family *Vespertilionidae*. N. Amer. Fauna #13.

Genus *Myotis* Kaup

1928. Gerrit S. Miller, Jr., and Glover, M. Allen. The American bats of the genera *Myotis* and *Pizonyx*. U. S. Nat. Mus., Bull. #144.

Myotis austroriparius (Rhoads)—Southeastern Little Brown Bat.

1897. *Vespertilio lucifugus austroriparius* Rhoads, Proc. Acad. Nat. Sci. Philadelphia, p. 227.

TYPE LOCALITY.—Tarpon Springs, Pinellas County, Florida.

RANGE.—“Vicinity of Tarpon Springs, Fla.; Mitchell, Indiana; Canada?” Miller and Allen, 1928, p. 76.

FLORIDA RECORDS:—Alachua County, Gainesville, Sherman, 1930, p. 495; Citrus County, 10 miles south of Inverness, HBS; Hillsborough County, Tampa Bay, Indian Key, UM; Jackson County, Mariana, HBS; Leon County, Tallahassee, E. V. Komarck; Levy County, Manatee Spring, WFB; Pinellas County, Bird Key, Tampa Bay, Miller and Allen, 1928, p. 78; Tarpon Springs, Rhoads, 1897, p. 227, Miller and Allen, 1928, p. 78.

Myotis grisescens A. H. Howell—Little Gray Bat.

1909. *Myotis grisescens* Howell, Proc. Biol. Soc. Washington, vol. 22, p. 46.

TYPE LOCALITY.—Nickajack Cave, near Shellmound, Marion County, Tennessee.

RANGE.—"Limestone area from extreme southern Indiana and Illinois south to Tennessee, Georgia, and central Alabama, westward to southwestern Missouri and Northern Arkansas." Miller and Allen, 1928, p. 81.

FLORIDA RECORDS:—Jackson County, Chipola River, north of Marianna. Sherman, 1934, p. 156.

Genus *Pipistrellus* Kaup

Pipistrellus subflavus subflavus (F. Cuvier)—Georgian Bat.

1832. *V[espertilio] subflavus* F. Cuvier, Nouv. ann. mus. hist. nat. Paris, vol. 1, p. 17.

TYPE LOCALITY.—Eastern United States, probably Georgia.

RANGE.—"Eastern United States, from the Atlantic coast to Iowa and southern Texas." Miller, 1924, p. 75.

FLORIDA RECORDS:—Alachua County, Alachua, Gainesville, Newberry, HBS; Citrus County, Blitches Ferry, Miller, 1898, p. 116; 10 miles south of Inverness, HBS; Dixie County, Old Town, Miller, 1898, p. 116; Pinellas County, Tarpon Springs, Rhoads, 1894, p. 157.

Genus *Eptesicus* Rafinesque

Eptesicus fuscus osceola Rhoads—Florida Big Brown Bat.

1902. *Eptesicus fuscus osceola* Rhoads, Proc. Acad. Nat. Sci. Philadelphia, for 1901, p. 618.

TYPE LOCALITY.—Tarpon Springs, Pinellas County, Florida.

RANGE.—Known only from region of type locality.

Genus *Lasiurus* Gray

Lasiurus borealis borealis (Müller)—Red Bat.

1776. *Vespertilio borealis* Müller, Natursyst. Suppl., p. 21.

TYPE LOCALITY.—New York.

RANGE.—"Boreal, transition, and Austral zones in eastern North America from Canada to Florida and Texas; west at least to Indian Territory and Colorado." Miller, 1924, p. 78.

FLORIDA RECORDS:—Alachua County, Gainesville, HBS; Dixie County, Old Town Miller, 1898, p. 216; Duval County, St. Marys River near Boulogne, HBS; Escambia County, Muscogee, U. S. Biol. Survey; Santa Rosa County, Mulat, U. S. Biol. Survey.

Lasiurus seminola (Rhoads)—Seminole Bat.

1895. *Atalapha borealis seminola* Rhoads, Proc. Acad. Nat. Sci. Philadelphia, p. 32.

TYPE LOCALITY.—Tarpon Springs, Hillsboro County, Florida.

RANGE.—Florida to Louisiana and South Carolina. One record each for Pennsylvania and Texas.

FLORIDA RECORDS:—Alachua County, Gainesville, HBS; 6 miles west of Lake Geneva, Acad. Nat. Sci. Philadelphia; Baker County, St. Marys River, Cornell Univ.; Brevard County, Micco, U. S. Biol. Survey; Citrus County, Blitches Ferry, Citronelle, Deer Creek, Miller, 1898, p. 217; Dixie County, Old Town, Miller, 1898, p. 217; Escambia County, Pensacola, HBS; Gulf County, Apalachicola, U. S. Biol. Survey; Hillsborough County, Lake Mobley, U. S. Biol. Survey; Leon County, Tallahassee, U. S. Nat. Museum; Levy County, Cedar Keys, HBS; Madison County, Cherry Lake, U. S. Biol. Survey; Nassau County, St. Marys River, Cornell Univ.; Pinellas County,

Seven Oaks, U. S. Biol. Survey; Tarpon Springs, Rhoads, 1895a, p. 36; Santa Rosa County, Mulat, U. S. Biol. Survey; Seminole County, Lake Harney, U. S. Biol. Survey; Wakulla County, St. Marks and Five miles above mouth of Aucilla River, U. S. Biol. Survey.

Lasiurus cinereus (Beauvois)—Hoary Bat.

1796. "*Vespertilio cinerea* (misspelled *linerea*) Beauvois, Catal. Raisonne Mus. Peale, Philadelphia, p. 18. (P. 15 of English edition of Peale and Beauvois.)" Miller, 1924, p. 79.

TYPE LOCALITY.—Philadelphia, Pennsylvania.

RANGE.—"Boreal North America from Atlantic to Pacific, breeding within the Boreal Zone, but in autumn and winter migrating at least to southern border of United States." Miller, 1924, p. 79.

FLORIDA RECORDS:—Alachua County, Gainesville, Chapman, 1894, p. 343.

Genus *Dasypterus* Peters

Dasypterus floridanus Miller—Florida Yellow Bat.

1902. *Dasypterus floridanus* Miller, Proc. Acad. Nat. Sci. Philadelphia, p. 392.

TYPE LOCALITY.—Lake Kissimmee, Florida.

RANGE.—"Florida and Gulf coast west to Louisiana." Miller, 1924, p. 80.

FLORIDA RECORDS:—Alachua County, Gainesville, HBS; Clay County, 6 miles north of Lake Geneva, Acad. Nat. Sci., Philadelphia; Nassau County, St. Marys River near Boulogne, HBS; Pinellas County, Polk County, Lakeland, HBS; Seven Oaks, U. S. Biol. Survey.

Genus *Nycticeius* Rafinesque

Nycticeius humeralis (Rafinesque) Bat.

1818. *Vespertilio humeralis* Rafinesque. American Monthly Magazine, vol. 3, p. 445.

TYPE LOCALITY.—Kentucky.

RANGE.—"Austral zones in the eastern United States, west to Arkansas and southern Texas." Miller, 1924, p. 80.

FLORIDA RECORDS:—Alachua, Gainesville, HBS; Brevard County, Titusville, Miller, 1898, p. 217; Citrus, Blitches Ferry, Citronelle, Miller, 1898, p. 217; Columbia County, Benton U. S. Biol. Survey; Dixie County, Old Town, Miller, 1898, p. 217; Escambia County, Pensacola HBS; Gadsden County, Chattahoochee, U. S. Biol. Survey; Hillsborough County, near Plant City, HBS; Tampa Bay, Indian Key, UM; Leon, Tallahassee, HBS; Marion County, Ocala, HBS; Osceola County, Kenansville, U. S. Biol. Surv.; Pinellas County, Tarpon Springs, Rhoads, 1894, p. 157; Putnam County, Shell Bluff, U. S. Biol. Survey; Seminole County, Mullet Lake, U. S. Biol. Survey.

Genus *Corynorhinus* H. Allen

Corynorhinus macrotis (Le Conte)—Le Conte Lump-nosed Bat.

1831. *Plec[otus] macrotis* Le Conte, McMurtrie's Cuvier, Animal Kingdom, vol. 1, p. 431.

TYPE LOCALITY.—"Georgia; probably the Le Conte plantation, near Riceboro, Liberty County." Miller, 1924, p. 83.

RANGE.—"Southeastern United States, from North Carolina, Georgia, and (?north-

ern) Florida, westward through the southern and Gulf States, into Louisiana, and probably eastern Texas." Miller, 1924, p. 83.

FLORIDA RECORDS:—Alachua County, Micanopy, H. Allen, 1893, p. 58.

FAMILY MOLOSSIDAE

Genus *Tadarida* Rafinesque

1931. H. Harold Shamel, Notes on the American bats of the genus *Tadarida*, Proc. U. S. Nat. Mus., vol. 78, Art. 19, pp. 1-27.

Tadarida cynocephala (Le Conte)—Le Conte Free-tailed Bat.

1831. *Nyct[icea] cynocephala* Le Conte, McMurtrie's Cuvier, Animal Kingdom, vol. 1, p. 432.

TYPE LOCALITY.—"Georgia; probably the Le Conte plantation, near Riceboro, Liberty County." Miller, 1924, p. 85.

RANGE.—"Louisiana, Alabama, Florida, Georgia, and South Carolina." Shamel, 1931, p. 8.

FLORIDA RECORDS:—Alachua County, Gainesville, Melrose, HBS; Citrus County, Blitches Ferry, Miller, 1898, p. 218; Hillsborough County, Tampa Bay, Indian Key, UM; Jefferson County, Wacissa River, Shamel, 1931, p. 8; Leon County, Tallahassee, E. V. Komarek; Osceola County, Kissimmee, Shamel, 1931, p. 8; Pinellas County, Indian Key, Fargo, 1929, p. 204; Tarpon Springs, Rhoads, 1894, p. 157; Sarasota County, Venice, Field Museum Nat. Hist.; Volusia County, Enterprise, Elliot, 1901, p. 57.

Genus *Eumops* Miller

Eumops glaucinus (Wagner)—Glaucous Mastiff Bat.

1843. *Dysopes glaucinus* Wagner, Weigmann's Archiv. f. Naturg., p. 368.

TYPE LOCALITY.—Cuyaba, Matta Grosso, Brazil.

RANGE.—"Colombia and Ecuador in South America, and Cuba and Jamaica in the West Indies." Sanborn, 1932, p. 353.

FLORIDA RECORDS:—Dade County, Miami, Barbour, 1936, p. 414.

ORDER CARNIVORA

FAMILY URSIDAE—BEARS

Genus *Euarctos* Gray

Euarctos floridanus (Merriam)—Florida Black Bear.

1896. *Ursus floridanus* Merriam, Proc. Biol. Soc. Washington, vol. 10, p. 81.

TYPE LOCALITY.—Key Biscayne, Dade County, Florida.

RANGE.—"Florida north into Georgia." Anthony, 1928, p. 76.

FLORIDA RECORDS:—Dade County, Key Biscayne, Merriam, 1896a, p. 81. Royal Palm State Park, Safford, 1919, p. 424; St. Johns County, Anastasia Island, Bangs, 1898, p. 221; Indian River, Bangs, 1898, p. 221.

FAMILY PROCYONIDAE

Genus *Procyon* Storr—Raccoons

Procyon lotor elucus Bangs—Florida Raccoon.

1898. *Procyon lotor elucus* Bangs, Proc. Boston Soc. Nat. Hist., vol. 28, pp. 219.

TYPE LOCALITY.—Oak Lodge, on peninsula opposite Micco, Brevard County, Florida.

RANGE.—"Florida and eastern Georgia." Anthony, 1928, p. 76.

FLORIDA RECORDS:—Alachua County, Gainesville, HBS, Brevard County, Oak Lodge, Bangs, 1898, p. 219; Citrus County, Citronelle, Bangs, 1898, p. 219; Dade County, 15 miles west of Royal Palm State Park, 10 miles east of Pine Crest, Blair, 1935b, p. 802-3; Duval County, New Berlin, Elliot, 1901, p. 53; Lake County, Lake Norris, HBS; Paradise Key, Safford, 1919, p. 424; Pine Crest, Blair, 1935b, p. 802-3; Pinellas County, Tarpon Springs, Rhoads, 1894, p. 155.

Procyon lotor marinus Nelson.—Chokoloskee Raccoon.

1930. *Procyon lotor marinus* Nelson, Smithsonian Misc. Coll., vol. 82, No. 8, p. 7.

TYPE LOCALITY.—Near Chokoloskee, Collier County, Florida.

RANGE.—Ten Thousand Islands, Florida.

Procyon lotor inesperatus Nelson.—Matecumbe Raccoon.

1930. *Procyon lotor inesperatus* Nelson, Smithsonian Misc. Coll. vol. 82, No. 8, p. 8.

TYPE LOCALITY.—Upper Matecumbe Key, Monroe County, Florida.

RANGE.—Key Largo Group, Monroe County, Florida, Virginia Key, Key Largo, Plantation Key, Upper Matecumbe Key, and Lower Matecumbe Key, Nelson, 1930, p. 9.

Procyon lotor auspicatus Nelson—Key Vaca Raccoon.

1930. *Procyon lotor auspicatus* Nelson, Smithsonian Misc. Coll., vol. 82, No. 8, p. 9.

TYPE LOCALITY.—Key Vaca, Monroe County, Florida.

RANGE.—Known only from type locality.

Procyon lotor incautus Nelson—Torch Key Raccoon.

1930. *Procyon lotor incautus* Nelson, Smithsonian Misc. Coll., vol. 82, No. 8, p. 10.

TYPE LOCALITY.—Torch Key, Monroe County, Florida.

RANGE.—Keys of the Big Pine group; No Name Key, Big Pine Key, Torch Key, Ramrod Key, Boca Chica Key, Stock Island, and Key West, Monroe County, Florida, Nelson, 1930, p. 11.

FAMILY MUSTELIDAE

Genus *Mustela* Linnaeus

1896. C. Hart Merriam. Synopsis of the weasels of North America. N. Amer. Fauna 11, U. S. Dept. Agric.

Mustela peninsulæ peninsulæ (Rhoads)—Florida Weasel.

1894. *Putorius peninsulæ* Rhoads, Proc. Acad. Nat. Sci. Philadelphia, p. 152.

TYPE LOCALITY.—Hudson, Pasco County, Florida.

RANGE.—"Peninsula of Florida; limits of range unknown." Miller, 1924, p. 121.

FLORIDA RECORDS:—Alachua County, Gainesville, Bangs, 1898, p. 232; Pasco County, Hudson, Rhoads, 1894, p. 152; Pinellas County, Tarpon Springs, Merriam, 1896b, p. 19; Seminole County, Osceola, Chapman, 1894, p. 345.

Mustela peninsulæ olivacea Howell—Alabama Weasel.

1913. *Mustela peninsulæ olivacea* Howell, Proc. Biol. Soc. Washington, vol. 26, p. 139.

TYPE LOCALITY.—Autaugaville, Autauga County, Alabama.

RANGE.—Alabama "except the mountainous regions of the northeastern part, but the limits of its range are at present unknown." Howell, 1921, p. 36.

FLORIDA RECORDS:—Alachua County, Gainesville, Sherman, 1929, p. 258.

Mustela vison lutensis (Bangs)—Florida Mink.

1898. *Putorius (Lutreola) lutensis* Bangs, Proc. Boston Soc. Nat. Hist., vol. 28, p. 229.

TYPE LOCALITY.—Salt marshes off Matanzas Inlet, St. Johns County, Florida.

RANGE.—“Coast of southeastern United States from South Carolina to Florida.” Miller, 1924, p. 125.

FLORIDA RECORDS:—Duval County, New Berlin, formerly common; none taken, Elliot, 1901, p. 54; Levy County, Cedar Keys, Maynard, 1883, p. 5; St. Johns County, Salt marshes opposite Matanzas Inlet, Bangs, 1898, p. 230; St. Johns River above Blue Springs, one seen, Maynard, 1872, p. 138.

Genus *Lutra* Brisson—Otters

Lutra canadensis vaga (Bangs)—Florida Otter.

1898. *Lutra hudsonica vaga* Bangs, Proc. Boston Soc. Nat. Hist., vol. 28, p. 224.

TYPE LOCALITY.—Micco, Brevard County, Florida.

RANGE.—“Florida and eastern Georgia.” Anthony, 1928, p. 116.

FLORIDA RECORDS:—Alachua County, Gainesville, HBS; Brevard County, Rose-land, Bangs, 1898, p. 224; Citrus County, Citronelle, Bangs, 1898, p. 224; Dade County, Royal Palm State Park, Safford, 1919, p. 424; Pinellas County, Tarpon Springs, Rhoads, 1894, p. 155; Walton County, Reported from Grayton Beach.

Genus *Spilogale* Gray

1906. A. H. Howell. Revision of the skunks of the genus *Spilogale*. N. Amer. Fauna No. 26, U. S. Dept. Agric.

Spilogale ambarvalis Bangs—Florida Spotted Skunk.

1898. *Spilogale ambarvalis* Bangs, Proc. Boston Soc. Nat. Hist., vol. 28, p. 222.

TYPE LOCALITY.—Oak Lodge, East Peninsula, opposite Micco, Brevard County.

RANGE.—Peninsular Florida.

FLORIDA RECORDS:—From Howell, 1920a, p. 88, unless otherwise stated.—Brevard County, Canaveral, Cape Canaveral, Oak, Lodge, Howell, 1906, p. 15; Collier County, 25 miles s.e. of Immokalee; Dade County, Coconut Grove, Lemon City; De Soto County, Arcadia; Manatee County, Palma Sola; Palm Beach County, Jupiter Inlet, Maynard, 1872, p. 140, Lake Worth; Palm Beach, Howell, 1906, p. 15; Volusia County, New Smyrna, Maynard, 1872, p. 140; Kissimmee Prairie, Merriam, 1890, p. 7.

Spilogale putorius (Linnaeus)—Alleghenian Spotted Skunk.

1758. *Viverra putorius* Linnaeus, Syst. Nat., ed. 10, p. 44.

TYPE LOCALITY.—South Carolina.

RANGE.—“Mississippi, Alabama, western Georgia, western South Carolina, and northward along the Alleghenies to northern Virginia; westward limits of range unknown.” Howell, 1906, p. 15.

FLORIDA RECORDS:—Leon County, Thomasville (Ga.)—Tallahassee area, Stoddard, 1932, p. 189. Also observed by A. F. Carr at Tallahassee.

Genus *Mephitis* Geoffroy and Cuvier

1901. A. H. Howell. Revision of the skunks of the genus *Chincha*. N. Amer. Fauna No. 20, U. S. Dept. Agric.

Mephitis elongata (Bangs)—Florida Skunk.

1895. *Mephitis mephitica elongata* Bangs, Proc. Boston Soc. Nat. Hist., vol. 26, p. 531.

TYPE LOCALITY.—Micco, Brevard County, Florida.

RANGE.—“Florida (from vicinity of Lake Worth) to North Carolina, and in the mountains to West Virginia; west of the Gulf coast to the Mississippi River.” Howell, 1901, p. 28.

FLORIDA RECORDS:—Alachua County, Gainesville, HBS; Brevard County, Micco, Bangs, 1895, p. 531; Citrus County, Blitche’s Ferry, Citronelle, Bangs, 1898, p. 222; Duval County, New Berlin, Bangs, 1898, p. 222; Franklin County, Beverly, Maynard, 1872, p. 139; Hernando County, Howell, 1901, p. 28; Indian River County, Sebastian, Howell, 1901, p. 28; Palm Beach County, Lake Worth, Howell, 1901, p. 28; Seminole County, Mullet Lake, Howell, 1901, p. 28; Volusia County, Enterprise, Elliot, 1901, p. 54; Lake Harney.

FAMILY CANIDAE

Genus *Urocyon* Baird—Gray Foxes

Urocyon cinereo-argenteus floridanus Rhoads—Florida Gray Fox.

1895. *Urocyon cinereo-argenteus floridanus* Rhoads, Proc. Acad. Nat. Sci. Philadelphia, p. 42.

TYPE LOCALITY.—Tarpon Springs, Pinellas County, Florida.

RANGE.—“Florida to eastern Texas.” Anthony, 1928, p. 144.

FLORIDA RECORDS:—Alachua County, Gainesville, HBS; Brevard County, Micco, Bangs, 1898, p. 233; Citrus County, Citronelle, Bangs, 1898, p. 233; Pinellas County, Tarpon Springs, Rhoads, 1895b, p. 42.

Genus *Canis* Linnaeus

Canis latrans Say—Coyote.

1823. *Canis latrans* Say, Long’s Exped. Rocky Mts., vol. 1, p. 168.

TYPE LOCALITY.—Engineer Cantonment, near present town of Blair, Washington County, Nebraska.

RANGE.—“Humid prairies and bordering woodlands of the northern Mississippi Valley, in Iowa and Minnesota, and northern edge of plains westward to the base of the Rocky Mountains in the Province of Alberta.” Miller, 1924, p. 151.

OCCURRENCE IN FLORIDA:—Brought into the state and liberated at Palm Beach County, 4 young ones in 1925; 2 escaped during the winter of 1925–26, fate of other 2 uncertain. H. H. Bailey, 1933. De Soto County, 10 reported liberated near Arcadia in 1925. H. H. Bailey, 1933. Gadsden County: 16 liberated in 1930 and 1931. All but 1 had been killed by May 1931. W. P. Woodbury (*in litt.*).

Canis rufus floridanus Miller—Florida Wolf.

1912. *Canis floridanus* Miller, Proc. Biol. Soc. Washington, vol. 25, p. 95.

1937. *Canis rufus floridanus* Goldman, Journ. Mamm., vol. 18, no. 1, pp. 45.

TYPE LOCALITY.—Horse Landing, about 12 miles south of Palatka, Putnam County, Florida.

RANGE.—Florida, northward to Georgia and Alabama and westward to Louisiana. Very rare or extinct in Florida.

FLORIDA RECORDS:—Lee County, a specimen examined by Chapman, 1894, p. 345; Palm Beach County, one seen in 1895 near Little Fish Crossing, southwest of Lake Worth, Cory, 1896, p. 110.

Cory also states a female and two cubs were killed in Big Cypress, ?Collier County, in 1894 by Robert Osceola.

Maynard, 1883, p. 5, states that “Gulf Hummocks” was the last stronghold of this

species and the last one was killed about 8 years ago, ?1875. He states that according to Mr. F. A. Ober they were formerly found about the Kissinee (probably misspelled for Kissimmee) River and Lake Okeechobee. Putnam County, Horse Landing, Miller, 1912, p. 95.

FAMILY FELIDAE

Genus *Felis* Linnaeus

1929. Nelson, E. W. and E. A. Goldman. List of the pumas, with three described as new. *Journal of Mammalogy*, vol. 10, pp. 345-350.

Felis concolor coryi Bangs—Florida Panther.

1899. *Felis coryi* Bangs, *Proc. Biol. Soc. Washington*, vol. 13, p. 15.

TYPE LOCALITY.—Wilderness back of Sebastian, Brevard County, Florida.

RANGE.—Florida, northward to Georgia and Alabama and westward to Louisiana.

FLORIDA RECORDS:—Cory, 1896, p. 42, States it was formerly common on the peninsula east of the Indian River, in Big Cypress south of Fort Myers, and in the vicinity of Lake Worth, Palm Beach County. Maynard, 1883, p. 3, states not more than 3 have been shot in "Gulf Hummocks" ?Levy County in the past 5 years. Safford, 1919, p. 424, states it is an occasional visitor in Paradise Key, Dade County. Its occurrence in the Okefenokee Swamp of southern Georgia. Harper, 1927, p. 317, and in Louisiana, Lowery, 1936, p. 23, indicates that it formerly occurred in suitable regions throughout Florida.

Genus *Lynx* Kerr

Lynx rufus floridanus (Rafinesque)—Florida Bobcat.

1817. *Lynx floridanus* Rafinesque, *American Monthly Magazine*, vol. 2, p. 46.

TYPE LOCALITY.—Florida.

RANGE.—"Florida, north to Georgia, west to Louisiana." Anthony, 1928, p. 167.

FLORIDA RECORDS:—Alachua County, Gainesville, HBS; Brevard County, Micco, Oak Lodge, Bangs, 1898, p. 234; Citrus County, Bangs, 1898, p. 234; Clay County, Lake Geneva, HBS; Dade County, Paradise Key and in the hammocks between Royal Palm State Park and Miami, Safford, 1919, p. 424; Duval County, New Berlin, Bangs, 1898, p. 234; Monroe County, Cape Sable, Blair, 1935b, p. 803.

ORDER RODENTIA

FAMILY SCIURIDAE

Genus *Sciurus* Linnaeus—Squirrels

1896. O. Bangs, A review of the squirrels of eastern North America. *Proc. Biol. Soc. Washington*, vol. 10, pp. 145-167.

Sciurus carolinensis carolinensis Gmelin—Southern Gray Squirrel.

1788. [*Sciurus*] *carolinensis* Gmelin, *Syst. Nat.*, vol. 1, p. 148.

TYPE LOCALITY.—"Carolina."

RANGE.—"From northern Florida north to about the lower Hudson Valley, west through the Alleghenies south of Pennsylvania to Indiana, Missouri, Oklahoma, and the edge of the plains." Miller, 1924, p. 223.

FLORIDA RECORDS:—Alachua County, Alachua, Gainesville HBS; Brevard County, Micco, Oak Lodge, Elliot, 1901, p. 35-36; Citrus County, Bangs, 1898, p. 205. Crystal River, Elliot, 1901, p. 35; Duval County, New Berlin, Bangs, 1898, p. 205; Elliot, 1901,

p. 35; Escambia County, East Pensacola Mountains, UM; Nassau County, Rose Bluff, St. Marys River, Bangs, 1898, p. 205; Pinellas County, Tarpon Springs, Elliot, 1901, p. 36; St. Petersburg, UM; Volusia County, Enterprise, Elliot, 1901, p. 35.

Sciurus carolinensis extimus Bangs—Everglade Gray Squirrel.

1896. *Sciurus carolinensis extimus* Bangs, Proc. Biol. Soc. Washington, vol. 10, p. 158.

TYPE LOCALITY.—Miami, Dade County, Florida.

RANGE.—“Subtropical fauna of south Florida, northward about half way up the peninsula.” Miller, 1924, p. 223.

FLORIDA RECORDS:—Brevard County, Oak Lodge, Eau Gallie, Bangs, 1898, p. 206; Dade County, Miami, Bangs, 1898, p. 206.

Sciurus niger niger Linnaeus—Southern Fox Squirrel.

1758. [*Sciurus niger* Linnaeus, Syst. Nat., ed. 10, vol. 1, p. 64.

TYPE LOCALITY.—“Probably southern South Carolina. (The type is based on Catesby’s black fox squirrel.)” Miller, 1924, p. 225.

RANGE.—“Florida and the southeastern states.” Miller, 1924, p. 225.

FLORIDA RECORDS:—Alachua County, Alachua, Gainesville, HBS; Citrus County, Citronelle, Bangs, 1898, p. 205; Duval County, New Berlin, Bangs, 1898, p. 205; Lake County, Lake Norris, HBS; Pinellas County, Tarpon Springs, Rhoads, 1894, p. 158.

Sciurus niger avicennia Howell—Mangrove Fox Squirrel.

1919. *Sciurus niger avicennia* Howell, Journ. Mamm., vol. 1, p. 37.

TYPE LOCALITY.—Everglades, Collier County, Florida.

RANGE.—“Mangrove forests of the southwest coast of Florida.” Miller, 1924, p. 226.

Genus *Glaucomys* Thomas

1918. A. H. Howell. Revision of the American Flying Squirrels. N. Amer. Fauna No. 44, U. S. Dept. Agric.

Glaucomys volans querceti (Bangs)—Florida Flying Squirrel.

1896. *Sciuropterus volans querceti* Bangs, Proc. Biol. Soc. Washington, vol. 10, p. 166.

TYPE LOCALITY.—Citronelle, Citrus County, Florida.

RANGE.—“Peninsular Florida (south at least to Ft. Myers) and the coast region of Georgia.” Howell, 1918, p. 26.

FLORIDA RECORDS:—From Howell, 1918, p. 27 unless otherwise stated; Alachua County, Gainesville, HBS; Citrus County, Citronelle, Bangs, 1898, p. 207; Duval County, New Berlin, Bangs, 1898, p. 207; Hernando County, Howell; Lee County, Ft. Myers; Marion County, Ocala; Nassau County, Pinellas County, Tarpon Springs; Volusia County, Enterprise, Lake Harney.

Glaucomys volans saturatus Howell—Southeastern Flying Squirrel.

1915. *Glaucomys volans saturatus* Howell. Proc. Biol. Soc. Washington, vol. 28, p. 110.

TYPE LOCALITY.—Dothan, Henry County, Alabama.

RANGE.—“Southeastern United States (excepting peninsular Florida and the coast region of Georgia) from South Carolina and western North Carolina west to central Oklahoma and north in the Mississippi Valley to southwestern Kentucky.” Howell, 1918, p. 24.

FLORIDA RECORDS:—Escambia County, Muscogee, Howell, 1918, p. 25; Santa Rosa County, Milton, Howell, 1918, p. 25.

FAMILY GEOMYIDAE—POCKET GOPHERS

1895. C. Hart Merriam. Monographic revision of the pocket gophers family Geomyidae. N. Amer. Fauna No. 8, U. S. Dept. Agric.

Genus *Geomys* Rafinesque

1898. Bangs, Proc. Boston Soc. Nat. Hist., vol. 28, pp. 175-178.

Geomys tuza mobilensis Merriam—Alabama Pocket Gopher.

1895. *Geomys tuza mobilensis* Merriam, N. Amer. Fauna No. 8, p. 119.

TYPE LOCALITY.—Point Clear, Mobile Bay, Baldwin County, Alabama.

RANGE.—“Southern Alabama and adjacent part of northwest Florida. . . .” Miller, 1924, p. 255.

FLORIDA RECORDS:—Escambia County, Pensacola, HBS; Santa Rosa County, Milton, Merriam, 1895a, p. 120.

Geomys floridanus floridanus (Audubon and Bachman)—Florida Pocket Gopher, Salamander or Sandymounder.

1854. *Pseudostoma floridana* Audubon and Bachman, Quad. N. Amer., vol. 3, p. 242.

TYPE LOCALITY.—St. Augustine, St. Johns County, Florida.

RANGE.—Eastern Florida from the St. Marys River to Eau Gallie, Brevard County. Intergrades with *G. f. austrinus* at Orlando and Gainesville. Bangs, 1898, p. 176.

FLORIDA RECORDS:—From Bangs, 1898a, p. 176 unless otherwise stated; Alachua County, Gainesville; Brevard County, Eau Gallie; Duval County, New Berlin; Gadsden County, Chattahoochee, Merriam; Nassau County, Rose Bluff; Orange County, Orlando; Putnam County, Pomona, Merriam, 1895a, p. 116; St. Johns County, St. Augustine.

Geomys floridanus austrinus Bangs—Southern Pocket Gopher or Salamander.

1898. *Geomys floridanus austrinus* Bangs, Proc. Boston Soc. Nat. Hist., vol. 28, p. 177.

TYPE LOCALITY.—Bellaire, Pinellas County, Florida.

RANGE.—“Western part of the Florida peninsula.” Bangs, 1898, p. 178.

FLORIDA RECORDS:—Pinellas County, Belleair, Tarpon Springs, Bangs, 1898, p. 177; De Soto County, Arcadia, Howell, 1919, p. 88, recorded as *G. tuza*, but is referable to this subspecies, A. H. Howell, (in litt.).

FAMILY CRICETIDAE

Genus *Reithrodontomys* Giglioli—American Harvest Mice

1914. A. H. Howell. Revision of the American harvest mice. N. Amer. Fauna No. 36, U. S. Dept. Agric.

Reithrodontomys humulis humutis (Audubon and Bachman)—Eastern Harvest Mouse.

1841. *Mus humulis* Audubon and Bachman, Proc. Acad. Nat. Sci. Philadelphia, p. 97.

TYPE LOCALITY.—Charleston, Charleston County, South Carolina.

RANGE.—“Southeastern United States, east of the Alleghenies, from southern Virginia to central Florida.” Howell, 1914, p. 19.

FLORIDA RECORDS:—From Howell, 1914, p. 20 unless otherwise stated; Alachua County, Gainesville, Micanopy, HBS; Osceola County, Kissimmee; Pasco County, Willow Oak; Pinellas County, Tarpon Springs; Polk County, Sawgrass Island; Volusia County, Enterprise.

Reithrodontomys humulis merriami (Allen)—Merriam Harvest Mouse.1895. *Reithrodontomys merriami* Allen, Bull. Amer. Mus. Nat. Hist., vol. 7, p. 119.

TYPE LOCALITY.—Austin Bayou, near Alvin, Brazoria County, Texas.

RANGE.—“Coast region of east Texas and southern Louisiana north to northeastern Kentucky and West Virginia; east to Alabama; limits of range imperfectly known.” Howell, 1914, p. 21. Southeast to Gainesville, Florida, Sherman, 1929, p. 259.

FLORIDA RECORDS:—Known only from Gainesville. Since this subspecies and *R. h. humulis* have both been taken at Gainesville, it seems probable that they intergrade in this region and that *R. h. merriami* occurs in the western part of the state.Genus **Peromyscus** Gloger—White-footed Mice. Deer Mice1909. Osgood, Revision of the mice of the American genus *Peromyscus*. N. Amer. Fauna No. 28, U. S. Dept. Agric.**Peromyscus polionotus polionotus** (Wagner)—Old Field Mouse.For distribution map of the subspecies of *P. polionotus* see Howell, 1920c, p. 238.1843. *Mus polionotus* Wagner, Wiegmann's Arch. f. Naturg., ix, vol. 2, p. 52.

TYPE LOCALITY.—Georgia.

RANGE.—“Southern Georgia, the greater part of eastern Alabama, and extreme northern Florida.” Howell, 1920, p. 237.

FLORIDA RECORDS:—Alachua County, Gainesville, Osgood, 1909, p. 105; New Berry, HBS.

Peromyscus polionotus niveiventris (Chapman)—Beach Mouse.1889. *Hesperomys niveiventris* Chapman, Bull. Amer. Mus. Nat. Hist., vol. 2, p. 117.

TYPE LOCALITY.—On the east peninsula, opposite Micco, Brevard County, Florida.

RANGE.—“Apparently confined to the ocean beaches on the Atlantic coast from Hillsboro Inlet (Broward County) north to Mosquito Inlet. (Volusia County, Florida.)” Howell, 1920, p. 237.

FLORIDA RECORDS:—From Osgood, 1909, p. 107, unless otherwise stated; Brevard County, Canaveral; Oak Lodge, Bangs, 1898, p. 199; Broward County, Hillsboro Inlet; Martin County, Jupiter Island; Palm Beach County, Lake Worth, Palm Beach, Bangs, 1898, p. 199; Volusia County, Mosquito Inlet, Howell, 1920, p. 237.

Peromyscus polionotus phasma (Bangs)—Anastasia Island White-footed Mouse.1898. *Peromyscus phasma* Bangs, Proc. Boston Soc. Nat. Hist., vol. 28, p. 199.

TYPE LOCALITY.—Point Romo, Anastasia Island, St. Johns County, Florida.

RANGE.—“Confined to Anastasia Island.” Howell, 1920, p. 237.

Peromyscus polionotus rhoadsi (Bangs)—Rhoads White-footed Mouse.1898. *Peromyscus subgriseus rhoadsi* Bangs, Proc. Boston Soc. Nat. Hist., vol. 28, p. 201.

TYPE LOCALITY.—Head of the Anclote River, Pasco County, Florida.

RANGE.—“Western side of the (Florida) peninsula in the region north of Tampa Bay and possibly ranges most of the way across to the Atlantic side, probably intergrading with both *niveiventris* and *polionotus*.” Howell, 1920, p. 237.

FLORIDA RECORDS:—From Osgood, 1909, p. 108; Citrus County, Citronelle; Pasco County, Head of Anclote River; Pinellas County, Tarpon Springs.

Peromyscus polionotus albifrons Osgood—White-fronted Beach Mouse.1909. *Peromyscus polionotus albifrons* Osgood, N. Amer. Fauna No. 28, p. 108.

TYPE LOCALITY.—Whitfield, Walton County, Florida.

RANGE.—“Region around Choctawatchee Bay, extreme western Florida, and . . . ocean beaches in southeastern Alabama east of Mobile Bay.” Howell, 1920, p. 237.

FLORIDA RECORDS:—Okaloosa County, Destin, HBS; Walton County, Whitfield, Osgood, 1909, p. 109.

Peromyscus polionotus leucocephalus Howell—White-headed Beach Mouse.

1920. *Peromyscus leucocephalus* Howell, Journ. Mamm., vol. 1, p. 239.

TYPE LOCALITY.—Santa Rosa Island (opposite Camp Walton), Escambia County, Florida.

RANGE.—“Confined to Santa Rosa Island.” Miller, 1924, p. 334.

Peromyscus gossypinus gossypinus (Le Conte)—Cotton Mouse.

1853. *Hesp[eromys] gossypinus* Le Conte, Proc. Acad. Nat. Sci. Philadelphia, vol. 6, p. 411.

TYPE LOCALITY.—“Georgia; probably the Le Conte Plantation, near Riceboro, Liberty County.” Miller, 1924, p. 337.

RANGE.—“Lowlands of the southeastern United States from the Dismal Swamp, Virginia, to northern Florida and west to Louisiana.” Osgood, 1909, p. 136.

FLORIDA RECORDS:—From Osgood, 1909, p. 138 unless otherwise stated; Alachua County, Gainesville; Duval County, Jacksonville, New Berlin; Gadsden County, Quincy, WFB; Nassau County, Amelia Island; Liberty County, Rock Bluff, HBS; Santa Rosa County, Milton; St. Johns County, Point Matanzas, Bangs, 1898, p. 195; Summer Haven; Walton County, Whitfield.

Peromyscus gossypinus palmarius Bangs—Florida Cotton Mouse.

1896. *Peromyscus gossypinus palmarius* Bangs, Proc. Biol. Soc. Washington, vol. 10, p. 124.

TYPE LOCALITY.—Oak Lodge, on the east peninsula opposite Micco, Brevard County, Florida.

RANGE.—“Peninsular Florida.” Osgood, 1909, p. 139.

FLORIDA RECORDS:—From Osgood, 1909, p. 140 unless otherwise stated; Brevard County, Canaveral, Cape Canaveral, Eau Gallie, Georgiana, Micco, Oak Lodge; Charlotte County, Charlotte Harbor; Citrus County, Bitches Ferry, Citronelle, Crystal River; Dade County, Miami, 10 miles east of Pine Crest, Blair, 1935b, p. 803; Levy County, Manatee Spring, WFB; De Soto County, Arcadia, HBS; Highlands County, Fort Kissimmee; Indian River County, Sebastian; Levy County, Gulf Hammock; Manatee County, Manatee, HBS; Martin County, Jupiter Island; Monroe County, Flamingo, Planter; Osceola County, Kissimmee; Palm Beach County, Jupiter Inlet, Bangs, 1898a, p. 195; Lake Worth; Pasco County, Anclote River, Port Richey; Pinellas County, Tarpon Springs; Polk County, Auburndale, Catfish Creek, Lake Arbuckle, Sawgrass Island; Seminole County, Mullet Lake; St. Lucie County, Eden; Volusia County, Enterprise, Glenwood, Lake Harney.

Peromyscus gossypinus anastasiae (Bangs)—Anastasia Island Cotton Mouse.

1898. *Peromyscus anastasiae* Bangs, Proc. Boston Soc. Nat. Hist., vol. 28, p. 195.

TYPE LOCALITY.—Point Romo, Anastasia Island, St. Johns County, Florida.

RANGE.—Sandy islands (possibly also parts of the mainland) of the eastern coast of coast of Georgia and Florida.” Osgood, 1909, p. 141.

FLORIDA RECORDS:—St. Johns County: Anastasia Island, Osgood, 1909, p. 141.

Peromyscus nuttalli aureolus (Aubudon and Bachman)—Southern Golden Mouse.

1841. *Mus (Calomys) aureolus* Audubon and Bachman, Proc. Acad. Nat. Sci. Philadelphia, vol. 1, p. 98.

TYPE LOCALITY.—“In the oak forests of South Carolina.” Osgood, 1909, p. 226.

RANGE.—“Southeastern United States from North Carolina to northern Florida; west to eastern Texas and Oklahoma.” Osgood, 1909, p. 226.

FLORIDA RECORDS:—From Osgood, 1909, p. 226 unless otherwise stated; Alachua County, High Springs, Gainesville, HBS; Duval County, Jacksonville; New Berlin, Bangs, 1898, p. 198; Leon County, Tallahassee; Liberty County, Rock Bluff, HBS; Marion County, Silver Springs, HBS; Putnam County, San Mateo; Santa Rosa County, Milton; Volusia County, Enterprise, Bangs, 1898, p. 198; Walton County, Whitfield.

Peromyscus floridanus (Chapman)—Florida White-footed Mouse.

1889. *Hesperomys floridanus* Chapman, Bull. Amer. Mus. Nat. Hist., vol. 2, p. 117.

TYPE LOCALITY.—Gainesville, Alachua County, Florida.

RANGE.—“The central part of peninsular Florida from coast to coast.” Osgood, 1909, p. 227.

FLORIDA RECORDS:—From Osgood, 1909, p. 228; Alachua County, Gainesville; Brevard County, Canaveral, Eau Gallie, Micco; Citrus County, Blich Ferry, Citronelle, Crystal River; Dade County, Miami; Indian River County, Sebastian; Marion County, Ocklawaha River; Palm Beach County, Lake Worth; Pinellas County, Tarpon Springs, Volusia County, Enterprise; Ft. Gardner, Kissimmee River.

Genus *Oryzomys* Baird—Rice Rats

1918. Edward A. Goldman. The rice rats of North America. N. Amer. Fauna No. 43, U. S. Dept. Agric.

Oryzomys palustris palustris (Harlan)—Swamp Rice Rat.

1837. *Mus palustris* Harlan, Silliman's Amer. Journ. Sci., vol. 31, p. 385.

TYPE LOCALITY.—“Fastland,” near Salem, Salem County, “New Jersey.” Goldman, 1918, p. 23.

RANGE.—“Atlantic coastal areas from southern New Jersey (not yet known from Delaware or Maryland, but doubtless occurs there) south to northeastern Florida, thence westward through southern Georgia to the Gulf coast of Alabama and Mississippi, and north through Alabama and western Tennessee to southwestern Kentucky, southern Illinois, and parts of southeastern Missouri. . . .” Goldman, 1918, p. 23.

FLORIDA RECORDS:—Duval County, Burnside Beach, New Berlin, Goldman, 1918, p. 24; Gadsden County, Quincy, WFB.

Oryzomys palustris natator Chapman—Central Florida Rice Rat.

1893. *Oryzomys palustris natator* Chapman, Bull. Amer. Mus. Nat. Hist., vol. 5, p. 44.

TYPE LOCALITY.—Gainesville, Alachua County, Florida.

RANGE.—“Central Florida, north of Everglades.” Goldman, 1918, p. 24.

FLORIDA RECORDS:—From Goldman, 1918, p. 25, unless otherwise stated; Alachua County, Gainesville; Brevard County, Canaveral, Cape Canaveral, Micco, Titusville; Citrus County, Crystal River; Highland County, Fort Kissimmee; Marion County, Ocala; Orange County, Orlando, Dept. of Biol. Univ. Fla.; Osceola County, Kissimmee; Pinellas County, Tarpon Springs; Seminole County, Geneva, Mullet Lake; St. Johns County, Anastasia Island, Cartersville; Volusia County, Enterprise, Espanita; Kissimmee River.

Oryzomys palustris colortus Bangs—Everglades Rice Rat.

1898. *Oryzomys palustris coloratus* Bangs, Proc. Boston Soc. Nat. Hist., vol. 28, p. 189.

TYPE LOCALITY.—Cape Sable, Monroe County, Florida.

RANGE.—“Tropical southern Florida, north to Lake Okechoobee.” Goldman, 1918, p. 26.

FLORIDA RECORDS:—From Goldman, 1918, p. 26, unless otherwise stated; Collier County, Everglade; Dade County, Miami, Miami River. 10 miles east of Pine Crest, Blair, 1935b p. 803; Paradise Key, Safford, 1919, p. 424; Monroe County, Cape Sable, Flamingo; Palm Beach County, Juno (Lake Worth), Jupiter; St. Lucie County, Eden.

Genus *Sigmodon* Say and Ord.—Cotton Rats

1902. Vernon Bailey. Synopsis of the North American species of *Sigmodon*. Proc. Biol. Soc. Washington, vol. 15, pp. 101–116.

Sigmodon hispidus hispidus Say and Ord.—Northern Cotton Rat.

1825. *S[igmodon] hispidum* Say and Ord, Journ. Acad. Nat. Sci. Philadelphia, vol. 4, pt. 2, p. 354.

TYPE LOCALITY.—St. Johns River, Florida.

RANGE.—“North Carolina to northern Florida and west to southern Louisiana.” Bailey, 1902, p. 104.

FLORIDA RECORDS:—Alachua County, Gainesville, Bailey, 1902, p. 104; Citrus County, Crystal River, Bangs, 1898, p. 191; Duval County, New Berlin, Bangs, 1898, p. 191; Gadsden County, Chattahoochee, Bailey, 1902, p. 104; Quincy, WFB; Putnam County, San Mateo, Bailey, 1902, p. 104; Santa Rosa County, Milton, Bailey, 1902, p. 104.

Sigmodon hispidus littoralis Chapman—Florida Cotton Rat.

1889. *Sigmodon hispidus littoralis* Chapman, Bull. Amer. Mus. Nat. Hist., vol. 2, p. 118.

TYPE LOCALITY.—East Peninsula, opposite Micco, Brevard County, Florida.

RANGE.—“Eastern part of the peninsula of Florida, from Lake Harney to the Everglades.” Bailey, 1902, p. 104.

FLORIDA RECORDS:—From Bailey, 1902, p. 104–5 unless otherwise stated; Brevard County, east peninsula opposite Micco; Eau Gallie, Bangs, 1898, p. 192; Micco, Chapman, 1894, p. 338; Titusville; Collier County, Everglade; Dade County, Miami; Flager County, Point Matanzas, Bangs, 1898, p. 192; Indian River County, Sebastian; Lee County, Pine Island, Charlotte Harbor, Chapman, 1889, p. 118; Palm Beach County, Jupiter Inlet, Bangs, 1898, p. 192; Pinellas County, St. Petersburg, UM; St. Johns County, Anastasia Island, Bangs, 1898, p. 192; St. Lucie County, Eden; Volusia County, Enterprise, Chapman, 1894, p. 338, Lake Kissimmee.

Sigmodon hispidus spadicipygus Bangs—Cape Sable Cotton Rat.

Sigmodon hispidus spadicipygus Bangs, Proc. Boston Soc. Nat. Hist., vol. 28, p. 192.

TYPE LOCALITY.—Cape Sable, Monroe County, Florida.

RANGE.—“The extreme southern part of the peninsula of Florida,” Bailey, 1902 p. 105.

FLORIDA RECORDS:—Dade County, ten miles east of Pine Crest, Blair, 1935b, p. 803; Monroe County, Cape Sable, Flamingo, Planter, Bailey, 1902, p. 105.

Sigmodon hispidus exputus G. M. Allen—Pine Key Cotton Rat.

1920. *Sigmodon hispidus exputus* G. M. Allen, Journ. Mamm., vol. 1, p. 236.

TYPE LOCALITY.—Big Pine Key, Monroe County, Florida.

RANGE.—Known only from type locality.

Genus *Neotoma* Say and Ord.—Wood Rats

1910. Edward A. Goldman. Revision of the wood rats of the genus *Neotoma*. N. Amer. Fauna No. 31, U. S. Dept. Agric.

Neotoma floridana floridana (Ord)—Florida Wood Rat.

1818. *Mus floridanus* Ord, Bull. soc. philom. Paris, p. 181.

TYPE LOCALITY.—“St. Johns River, Florida. (Probably in the vicinity of Jacksonville.)” Bangs, 1898a, p. 184.

RANGE.—“Atlantic coast region from South Carolina to Sebastian, Florida.” Goldman, 1910, p. 21. Also westward throughout all but northern Alabama. Howell, 192 p. 53.

FLORIDA RECORDS:—From Goldman, 1910, p. 22, unless otherwise stated; Alachua County, Gainesville, Lake Wauburg, HBS; Brevard County, Micco; Citrus County, Bangs, 1898, p. 184; Duval County, New Berlin, Bangs, 1898, p. 184; Indian River County, Sebastian; Osceola County, Kissimmee; Putnam County, San Mateo; Volusia County, Enterprise.

Genus *Pitymys* McMurtrie—Pine Mice

Revised under the generic name *Microtus*, subgenus *Pitymys*, by Vernon Bailey, 1900. Revision of American Voles of the genus *Microtus*. N. Amer. Fauna No. 17, pp. 62–67.

Pitymys parvulus Howell—Florida Pine Mouse.

1916. *Pitymys parvulus* Howell, Proc. Biol. Soc. Washington, vol. 29, p. 83.

TYPE LOCALITY.—Lynne Planting Station of the U. S. Forest Service, near the town of Lynne, Marion County, Florida. Howell, 1934, p. 72.

RANGE.—Type locality and Gainesville, Sherman, 1929, p. 258. Two specimens in the author's collection, received from J. R. Watson, taken at Quincy, Gadsden County, are tentatively referred to this species.

Genus *Neofiber* True—Round-tailed Muskrats

Revised under the generic name *Microtus*, subgenus *Neofiber*, by Vernon Bailey, 1900. Revision of American voles of the genus *Microtus*. N. Amer. Fauna No. 17, pp. 78–79.

Neofiber alleni alleni True—Florida Round-tailed Muskrat.

1884. *Neofiber alleni* True, Science, vol. 4, p. 34.

TYPE LOCALITY.—Georgiana, Brevard County, Florida.

RANGE.—Possibly confined to the salt-water regions of the east coast of Florida. Limits of range unknown.

FLORIDA RECORDS:—Brevard County, Canaveral, Georgiana, Oak Lodge on the east peninsula opposite Micco, Titusville, Bailey, 1900, p. 79; St. Lucie County, Eden, Bailey, 1900, p. 79.

Neofiber alleni nigrescens Howell—Everglade Round-tailed Muskrat.

1920. *Neofiber alleni nigrescens* Howell, Journ. Mamm., vol. 1, p. 79.

TYPE LOCALITY.—Ritta, Palm Beach County, Florida.

RANGE.—Fresh water prairies from southern Florida to Okefinokee Swamp, southeastern Georgia.

FLORIDA RECORDS:—Alachua County, Gainesville, Bangs, 1898, p. 183. Santa Fe Lake, HBS; Collier County, Head of Barnes River, Howell, 1920, p. 79; Broward

County, Zona, near Fort Lauderdale, Howell, 1920, p. 79; Monroe County?, Cape Sable, Howell, 1920, p. 79; Skull only, subspecies questionable; Palm Beach County, Ritta, Canal Point, Howell, 1920, p. 79; Putnam County, Crescent City, HBS; Volusia County, Enterprise, Bangs, 1898, p. 183.

FAMILY MURIDAE—OLD WORLD RATS AND MICE

Genus *Rattus* G. Fischer

Rattus rattus rattus (Linnaeus)—Black Rat.

1758. [*Mus*] *rattus* Linnaeus, Syst. Nat., ed. 10, vol. 1, p. 61.

TYPE LOCALITY.—Upsala, Sweden.

RANGE.—“Introduced and widely distributed in North America.” Miller, 1924, p. 428.

FLORIDA RECORDS:—Alachua County, Gainesville, HBS; Monroe County, Flamingo, Blair, 1935b, p. 804; Sarasota County, Englewood, HBS; Volusia County, Enterprise, Chapman, 1894, p. 339.

Rattus rattus alexandrinus (Geoffroy)—Roof Rat.

1803. *Mus alexandrinus* Geoffroy, Catal. Mammaif. du Mus. Nat. d'Hist. Nat., Paris, p. 192.

TYPE LOCALITY.—Alexandria, Egypt.

RANGE.—“Introduced and widely established in North America.” Miller, 1924, p. 429.

FLORIDA RECORDS:—Alachua County, Gainesville, HBS; Collier County, Ten Thousand Islands, Nelson, 1930, p. 4; Monroe County, Cape Sable, Flamingo, Blair, 1935b, p. 804; Pinellas County, Indian Key, North Tampa Bay, Fargo, 1929, p. 203; Sarasota County, Englewood, HBS; Tarpon Springs, Rhoads, 1894, p. 139.

Rattus norvegicus (Erxleben)—Norway Rat.

1777. [*Mus*] *norvegicus* Erxleben, Syst. Regni Anim., vol. 1, p. 381.

TYPE LOCALITY.—Norway.

RANGE.—“Introduced and widely established in North America.” Miller, 1924, p. 429.

FLORIDA RECORDS:—Duval County, Jacksonville, Bangs, 1898, p. 204; Pinellas County, Tarpon Springs, Rhoads, 1894, p. 259.

Genus *Mus* Linnaeus

Mus musculus musculus Linnaeus—House Mouse.

1758. [*Mus*] *musculus* Linnaeus, Syst. Nat., ed. 10, vol. 1, p. 62.

TYPE LOCALITY.—Upsala, Sweden.

RANGE.—“Introduced and widely established in North America.” Miller, 1924, p. 429.

FLORIDA RECORDS:—Alachua County, Gainesville, HBS; Monroe County, Key West, Bangs, 1898, p. 203; Pinellas County, Tarpon Springs, Rhoads, 1894, p. 159.

ORDER LAGOMORPHA

FAMILY LEPORIDAE—HARES, RABBITS, COTTONTAILS, ETC.

Genus *Sylvilagus* Gray—Cottontails and Marsh Rabbits

1909. E. W. Nelson. The rabbits of North America. N. Amer. Fauna No. 29.

Sylvilagus floridanus floridanus (Allen)—Florida Cottontail.

1890. *Lepus sylvaticus floridanus* Allen, Bull. Amer. Mus. Nat. Hist., vol. 3, p. 160.

TYPE LOCALITY.—Sebastian River, Brevard County, Florida.

RANGE.—“All of peninsular Florida (including coastal islands) south of Sebastian River and thence northward along the coast to St. Augustine on the east side, and to an unknown distance on the west side.” Nelson, 1909, p. 164.

FLORIDA RECORDS:—From Nelson, 1909, p. 165; Brevard County, Micco, Oak Lodge; Citrus County, Blitches Ferry, Citronelle; Dade County, Miami; Indian River County, Sebastian; Osceola County, Camp Hammock, UM; Palm Beach County, Lake Worth; Pinellas County, Tarpon Springs, UM; Polk County, Saw Grass Island; Putnam County, San Mateo; Seminole County, Mullet Lake; Volusia County, Enterprise, Kissimmee River.

Sylvilagus floridanus mallurus (Thomas)—Eastern Cottontail.

1898. *L[epus] n[uttalli] mallurus* Thomas, Ann. and Mag. Nat. Hist., ser. 7, vol. 2, p. 320.

TYPE LOCALITY.—Raleigh, Wade County, North Carolina.

RANGE.—“Mainly east of Allegheny Mountains from Long Island and the lower Hudson Valley in extreme southern New York south through New Jersey, Delaware, eastern Pennsylvania, eastern West Virginia, Maryland, Virginia, North and South Carolina, Georgia, except northwestern part, and west along Gulf coast to near Mobile Bay, and Alabama; also northwestern central parts of Florida south to about Lake Julian, Polk County.” Nelson, 1909, p. 166.

FLORIDA RECORDS:—From Nelson, 1909, p. 168, unless otherwise stated; Alachua County, Gainesville; Gadsden County, Chattahoochee; Quincy, WFB; Liberty County, Rock Bluff, HBS; Polk County, Lake Julian.

Sylvilagus palustris palustris (Bachman)—Carolina Marsh Rabbit.

1837. *Lepus palustris* Bachman, Journ. Acad. Nat. Sci. Philadelphia, vol. 7, p. 194.

TYPE LOCALITY.—Eastern South Carolina.

RANGE.—“Lowlands along rivers and coast of southeastern States from Dismal Swamp, Virginia, south to extreme northern Florida, and west through most of southern Georgia and the Gulf Coast of northwestern Florida to the east side of Mobile Bay, Alabama.” Nelson, 1909, p. 266.

FLORIDA RECORDS:—From Nelson, 1909, p. 269, unless otherwise stated; Escambia County, Bohemia, UM; Franklin County, Apalachicola, UM; St. Johns County: Anastasia Island; Walton County, Whitfield.

Sylvilagus palustris paludicola (Miller and Bangs)—Florida Marsh Rabbit.

1894. *Lepus paludicola* Miller and Bangs, Proc. Biol. Soc. Washington, vol. 9, p. 105.

TYPE LOCALITY.—Fort Island, near Crystal River, Citrus County, Florida.

RANGE.—“Peninsular Florida and adjacent coast islands, north along the east coast at least to San Mateo, and on the west side for an unknown distance beyond the Suwanee River.” Nelson, 1909, p. 269.

FLORIDA RECORDS:—From Nelson, 1909, p. 270 unless otherwise stated; Alachua County, Gainesville, Blair, 1936, p. 197; Brevard County, Canaveral, Micco, Oak Lodge; Citrus County, Fort Island, near Crystal River; Clay County, Hibernia; Collier County, Little Marco; Dade County, Paradise Key, Safford, 1919, p. 424; Highlands County, Fort Kissimmee; Lake County, Mt. Dora Lake, UM; Levy County, Manatee Spring, WFB; Osceola County, Kissimmee; Pinellas County, Belleair, Tarpon Springs, Indian Pass, UM, John's Pass, UM; Putnam County, Drayton Island, San Mateo; Seminole County, Mullet Lake; Volusia County, Enterprise, Kissimmee River, Lake Kissimmee, Suwanee River, Lake Harney.

ORDER ARTIODACTYLA—EVEN-TOED, HOOFED MAMMALS

FAMILY CERVIDAE—DEER

Genus *Odocoileus* Rafinesque

1922. Thomas Barbour and Glover M. Allen. The white-tailed deer of the eastern United States. Journ. Mamm., vol. 3, pp. 65–78.

Odocoileus virginianus virginianus (Boddaert)—Virginia Deer.

1784. [*Cervus*] *virginianus* Boddaert, Elenchus Animalium, vol. 1, p. 136.

TYPE LOCALITY.—Virginia.

RANGE.—“Found in the eastern United States north to southern New York(?) and south to Florida; limits of range uncertain.” Anthony, 1928, p. 518.

FLORIDA RECORDS:—From Barbour and Allen, 1922, p. 69; Brevard County, Kissimmee Prairie; Citrus County, Citronelle; Indian River County, Sebastian; Palm Beach County, Palm Beach; Volusia County, New Smyrna.

Odocoileus virginianus osceola (Bangs)—Florida Deer.

1896. *Cariacus osceola* Bangs, Proc. Biol. Soc. Washington, vol. 10, p. 26.

TYPE LOCALITY.—Citronelle, Citrus County, Florida.

RANGE.—The more southern part of peninsular Florida. Barbour and Allen consider the type an “extreme intergrade” with *O. v. virginianus*.

FLORIDA RECORDS:—From Barbour and Allen, 1922, p. 73; Citrus County, Citronelle, Blitches Ferry. Intergrades with typical *virginianus*; Collier County, Chokoloskee. Typical *O. v. osceola*; Polk County, Lake Arbuckle. Intergrades with *O. v. virginianus*.

Odocoileus virginianus clavium Barbour and Allen—Key Deer.

1922. *Odocoileus virginianus clavium* Barbour and G. M. Allen, Journ. Mamm., vol. 3, p. 73.

TYPE LOCALITY.—Big Pine Key, Monroe County, Florida.

RANGE.—Big Pine Key to Boca Chinca and formerly to Key West Island. Barbour and Allen, 1922, p. 74.

ORDER XENARTHRA

FAMILY DASYPODIDAE—ARMADILLOS

Genus *Dasypos* Linnaeus

Dasypos novemcinctus texanus (Bailey)—Texas Nine-banded Armadillo.

1905. *Tatu novemcinctum texanum* Bailey, North Amer. Fauna No. 25, p. 52.

TYPE LOCALITY.—Brownsville, Cameron County, Texas.

RANGE.—“From the Rio Grande of Texas south into Mexico; north to about 33° latitude and west to Devils River.” Anthony, 1928, p. 551.

OCCURRENCE IN FLORIDA:—A pair is reported to have been brought from Texas to Miami during the World War by a marine. One was killed near Miami, by a dog in 1922 and a female with 4 young was killed in February 1924. H. H. Bailey, 1924.

Armadillos are also reported to be occasionally killed by dogs in the region of Cocoa, Brevard County, Fla. These are said to have been imported from Texas and were liberated when the Cocoa Zoo was destroyed by a storm in about 1924. Cocoa Tribune, vol. xx, No. 40, Dec. 10, 1936. A captive in the zoo at Scholtz Field, Daytona, is reported to have been captured near Titusville, Brevard County in the autumn of 1936. Another is said to have been shot at Flagler Beach, Flagler County, about 1934.

LITERATURE CITED

- ALLEN, GLOVER M. 1920. An insular race of cotton rat from the Florida keys. *Journ. Mamm.*, vol. 1, pp. 235-236.
- ALLEN, HARRISON. 1893. A monograph of the bats of North America. *Bull. U. S. Nat. Mus.*, No. 43.
- ALLEN, J. A. 1871. On the mammals and winter birds of east Florida, with an examination of certain assumed specific characters in birds, and a sketch of the bird-fauna of eastern North America. *Bull. Mus. Comp. Zool.*, vol. 2, pp. 161-540.
- 1890. Descriptions of a new species and a new subspecies of the genus *Lepus*. *Bull. Amer. Mus. Nat. Hist.*, vol. 3, pp. 159-160.
- 1895. On the species of the genus *Reithrodontomys*. *Bull. Amer. Mus. Nat. Hist.*, vol. 7, p. 107-143.
- 1901. A preliminary study of the North American opossums of the genus *Didelphis*. *Bull. Amer. Mus. Nat. Hist.*, vol. 14, pp. 149-188.
- ANDERSEN, KNUD. 1908. A monograph of the chiropteran genera *Uroderma*, *Enchisthenes*, and *Artibeus*. *Proc. Zool. Soc. London*, pp. 204-319.
- ANTHONY, H. E. 1928. *Field Book of North American Mammals*. G. P. Putnam's Sons, New York.
- AUDUBON and BACHMAN. 1841. Descriptions of new species of North American quadrupeds. *Proc. Acad. Nat. Sci. Philadelphia*, vol. 1, pp. 92-103.
- 1854. *The viviparous quadrupeds of North America*. Vol. 3. Vol. 1 is dated 1846, and vol. 2, 1851.
- BACHMAN, J. 1837a. Some remarks on the genus *Sorex*, with a monograph of the North American species. *Journ. Acad. Nat. Sci. Philadelphia*, vol. 7, pt. 2, pp. 362-402, pls. 23-24.
- 1837b. Description of a new species of hare (*Lepus palustris*) found in South Carolina. *Journ. Acad. Nat. Sci. Philadelphia*, vol. 7, pt. 2, pp. 194-199, Pls. "16" (i.e., 15) and 16, figs. 1 and 2.
- BAILEY, H. H. 1924. The armadillo in Florida and how it reached there. *Journ. Mamm.* vol. 5, no. 4, pp. 264-265.
- 1930. Correcting inaccurate ranges of certain Florida mammals and others of Virginia and the Carolinas. *Bull. No. 5, Bailey Mus. and Lib. Nat. Hist.*, Miami.
- 1933. Coyotes (*Canis latrans*) in Florida. *Bull. No. 8, Bailey Mus. and Lib. Nat. Hist.*, Miami.
- BAILEY, VERNON. 1900. Revision of the American voles of the genus *Microtus*. *N. Amer. Fauna No. 17, U. S. Dept. Agric.*
- 1902. Synopsis of the North American species of *Sigmodon*. *Proc. Biol. Soc. Washington*, vol. 15, pp. 101-116.
- 1905. Biological survey of Texas. *N. Amer. Fauna No. 25, U. S. Dept. Agric.*
- BANGS, OUTRAM. 1895. Notes on North American Mammals. The synonymy of the eastern skunk, *Mephitis mephitis* (Shaw), with the description of a new subspecies from Florida. *Proc. Boston Soc. Nat. Hist.*, vol. 26, pp. 529-536.
- 1896a. A review of the squirrels of eastern North America. *Proc. Biol. Soc. Washington*, vol. 10, pp. 145-167.
- 1896b. The cotton mouse, *Peromyscus gossypinus*. *Proc. Biol. Soc. Washington*, vol. 10, pp. 119-125.
- 1896c. The Florida deer. *Proc. Biol. Soc. Washington*, vol. 10, pp. 25-28.

- 1898. The land mammals of peninsular Florida and the coast region of Georgia. Proc. Boston Soc. Nat. Hist., vol. 28, pp. 157-235.
- 1899. The Florida puma. Proc. Biol. Soc. Washington, vol. 13, pp. 15-17.
- BARBOUR, THOMAS. 1936. *Eumops* in Florida. Journ. Mamm., vol. 17, no. 4, pp. 414.
- and Glover M. Allen. 1922. The white-tailed deer of eastern United States. Journ. Mamm., vol. 3, no. 2, pp. 65-78, pls. 4 and 5.
- BEAUVOIS, PALISOT DE. 1796. Catalogue Raisonne Mus. Peale, Philadelphia.
- BLAIR, W. FRANK. 1935a. The mammals of a Florida hammock. Journ. Mamm., vol. 16, no. 4, pp. 271-277.
- 1935b. Some mammals of southern Florida. Amer. Midland Naturalist., vol. 16, pp. 801-804.
- 1936. The Florida marsh rabbit. Journ. Mamm., vol. 17, pp. 3, pp. 197-207.
- BODDAERT, P. 1784. Elenchus animalium, vol. 1.
- CHAPMAN, FRANK M. 1889a. Preliminary descriptions of two apparently new species of the genus *Hesperomys* from Florida. Bull. Amer. Mus. Nat. Hist., vol. 2, p. 117.
- 1889b. Description of a new species of *Sigmodon* from southern Florida. Bull. Amer. Mus. Nat. Hist., vol. 2, p. 118.
- 1893a. Description of two new races of mammals from Florida, with remarks on *Sitomys niveiventris* Chapman. Bull. Amer. Mus. Nat. Hist., vol. 5, pp. 339-341.
- 1893b. Description of a new subspecies of *Oryzomys* from the Gulf states. Bull. Amer. Mus. Nat. Hist., vol. 5, pp. 43-46.
- 1894. Remarks on certain land mammals from Florida, with a list of the species known to occur in the state. Bull. Amer. Mus. Nat. Hist., vol. 6, pp. 333-346.
- CORY, CHARLES B. 1896. Hunting and fishing in Florida. Estes and Lauriat, Boston.
- CUVIER, F. 1832. Nouv. Annales du Museum d'Histoire Naturelle, Paris, vol. 1.
- ELLIOT, D. G. 1901. A list of mammals obtained by Thaddeus Surber in North and South Carolina, Georgia and Florida. Field Columbian Museum Publication 58. Zool. Ser., vol. 3, no. 4.
- ERXLEBEN, J. C. P. 1777. Systema regni animalis per classes, ordines, genera, species, varietates, cum synonymia et historia animalium. Classis I, Mammalia.
- FARGO, WM. G. 1929. Bats of Indian Key, Tampa Bay, Florida. Journ. Mamm., vol. 10, no. 3, pp. 203-205.
- GEOFFROY, ST. HILAIRE. 1803. Catal. Mammif. du Mus. Nat. d'Hist. Nat., Paris.
- GMELIN, J. F. 1788. Caroli a Linne Systema naturae per regna tria naturae, secundum classes ordines, genera, species, cum characteribus, differentiis, synonymis, locis. Ed. 13ma, aucta reformata. Tomus I, pars 1, Mammalia.
- GOLDMAN, EDWARD A. 1910. Revision of the wood rats of the genus *Neotoma*. N. E. Amer. Fauna No. 31, U. S. Dept. Agric.
- 1918. The rice rats of North America. N. Amer. Fauna No. 43, U. S. Dept. Agric.
- 1937. The wolves of North America. Journ. Mamm., vol. 18, no. 1, pp. 37-45.
- HARLAN, R. 1837. Description of a new species of Quadruped, of the order Rodontia, inhabiting the United States. Silliman's Amer. Journ. Sci., vol. 31.
- HARPER, FRANCIS. 1927. The mammals of the Okefinokee Swamp Region of Georgia. Proc. Boston Soc. Nat. Hist., vol. 38, no. 7, pp. 191-396, pl. 4-7.
- HOWELL, ARTHUR H. 1901. Revision of the skunks of the genus *Chincha*. N. Amer. Fauna No. 20, U. S. Dept. Agric.

- 1906. Revision of the skunks of the genus *Spilogale*. N. Amer. Fauna No. 26, U. S. Dept. Agric.
- 1909. Description of a new bat from Nickajack Cave, Tennessee. Proc. Biol. Soc. Washington, vol. 22, pp. 45-48.
- 1913. Description of a new weasel from Alabama. Proc. Biol. Soc. Washington, vol. 26, pp. 139-140.
- 1914. Revision of the American harvest mice. N. Amer. Fauna No. 36, U. S. Dept. Agric.
- 1915. Descriptions of a new genus and seven new races of flying squirrels. Proc. Biol. Soc. Washington, vol. 28, pp. 109-114.
- 1916. Description of a new pine mouse from Florida. Proc. Biol. Soc. Washington, vol. 29, pp. 83-84.
- 1918. Revision of the American flying squirrels. N. Amer. Fauna No. 44, U. S. Dept. Agric.
- 1919. Notes on the fox squirrels of southeastern United States, with description of a new form from Florida. Journ. Mamm., vol. 1, no. 1, pp. 36-38.
- 1920a. The Florida spotted skunk as an acrobat. Journ. Mamm., vol. 1, no. 2, p. 88.
- 1920b. A new race of the Florida water rat. Journ. Mamm., vol. 1, no. 2, pp. 79-80.
- 1920c. Description of a new species of beach mouse from Florida. Journ. Mamm., vol. 1, no. 5, pp. 237-240.
- 1921. A biological survey of Alabama. II. The mammals. N. Amer. Fauna No. 45, U. S. Dept. Agric.
- 1929. Florida's mammals. Nature Magazine, vol. 14, no. 6, pp. 338-340, 378-379.
- 1934. The type locality of *Pitymys parvulus*. Journ. Mamm., vol. 15, p. 72.
- JACKSON, HARTLEY H. T. 1914. New moles of the genus *Scalopus*. Proc. Biol. Soc. Washington, vol. 27, pp. 19-22.
- 1915. A review of the American moles. N. Amer. Fauna No. 38, U. S. Dept. Agric.
- 1928. A taxonomic review of the American long-tailed shrews. N. Amer. Fauna No. 51, U. S. Dept. Agric.
- LE CONTE, J. 1831. The animal kingdom arranged in conformity with its organization. By the Baron Cuvier, and translated from the French, with notes and additions, by H. McMurtrie, M.D. 4 vols. Mammals in vol. 1.
- 1853. Descriptions of three new species of American Arvicolae, with remarks on some other North American rodents. Proc. Acad. Nat. Sci. Philadelphia, vol. 6, pp. 404-415.
- LINNAEUS, C. 1758. Systema naturae per regna tria naturae, secundum classes, ordines, genera, species, cum characteribus, differentiis, synonymis, locis. Editio decima, reformata. Tomus I. Regnum animale.
- LOWERY, GEORGE H. 1936. A preliminary report on the distribution of the mammals of Louisiana. Proc. Louisiana Acad. Sci., vol. 3, pp. 11-39.
- MAYNARD, C. J. 1872. Catalog of the mammals of Florida, with notes on their habits, distribution, etc.—Bull. Essex Inst., vol. 4, pp. 135-150.
- 1883. The mammals of Florida. Quarterly Journ. Boston Zool. Soc., vol. 2, no. 1, pp. 1-8, no. 2, 17-24, no. 3, 38-43, no. 4, 49-50.

- MERRIAM, C. HART. 1890. Revision of the genus *Spilogale*. N. Amer. Fauna No. 4, U. S. Dept. Agric.
- 1895a. Monographic revision of the pocket gophers, Family Geomyidae (exclusive of the species of *Thomomys*). N. Amer. Fauna No. 8, U. S. Dept. Agric.
- 1895b. Revision of the shrews of the genera *Blarina* and *Notiosorex*. N. Amer. Fauna No. 10, pp. 5-34, U. S. Dept. Agric.
- 1896a. Preliminary synopsis of the American bears. Proc. Biol. Soc. Washington, vol. 10, pp. 65-83.
- 1896b. Synopsis of the weasels of North America. N. Amer. Fauna No. 11, U. S. Dept. Agric.
- MILLER, GERRIT S. JR. 1897. Revision of the North American bats of the family Vespertilionidae. N. Amer. Fauna No. 13, U. S. Dept. Agric.
- 1898. In Bangs, The land mammals of peninsular Florida and the coast region of Georgia, Proc. Boston Soc. Nat. Hist., vol. 28, pp. 213-218.
- 1902. Twenty new American bats. Proc. Acad. Nat. Sci. Philadelphia, vol. 54, pt. 2, pp. 389-412.
- 1912. The names of two North American wolves. Proc. Biol. Soc. Washington, vol. 25, pp. 95.
- 1924. List of North American recent mammals 1923. Bull. 128, U. S. Nat. Mus.
- and Glover M. Allen. 1928. The American bats of the genera *Myotis* and *Pizonyx*. Bull. 144, U. S. Nat. Mus.
- and Outram Bangs. 1894. A new rabbit from western Florida. Proc. Biol. Soc. Washington, vol. 9, pp. 105-108.
- MÜLLER, P. L. S. 1776. Des Ritters Carl von Linne vollständiges Natursystem, Bd. 1-vi und suppl.
- NELSON, EDWARD W. 1909. The rabbits of North America. N. Amer. Fauna 29, U. S. Dept. Agric.
- 1930. Four new raccoons from the keys of southern Florida. Smithsonian Misc. Coll., vol. 82, no. 8, pp. 1-12, pls. 1-5.
- and E. A. Goldman. 1929. List of the pumas, with three described as new. Journal of Mammalogy, vol. 10, pp. 345-350.
- ORD, GEORGE. 1818. Sur une nouvelle espèce de rongeur de la Floride. Bull. soc. philom. Paris, December, pp. 181-182.
- OSGOOD, WILFRED H. 1909. Revision of the mice of the American genus *Peromyscus*. N. Amer. Fauna No. 28, U. S. Dept. Agric.
- RAFINESQUE, C. S. 1817. Description of seven new genera of North American quadrupeds. Amer. Monthly Magazine, vol. 2, pp. 44-46.
- 1818. Further discoveries in Natural History, made during a journey through the Western States. Amer. Monthly Magazine, vol. 3, pp. 445, 446.
- RHOADS, SAMUEL N. 1894. Contributions to the mammalogy of Florida. Proc. Acad. Nat. Sci. Philadelphia, pp. 152-161.
- 1895a. Descriptions of new mammals from Florida and southern California. Proc. Acad. Nat. Sci. Philadelphia, pp. 32-37.
- 1895b. New subspecies of the gray fox and Say's chipmunk. Proc. Acad. Nat. Sci. Philadelphia, pp. 42-44.
- 1897. A new southeastern race of the little brown bat. Proc. Acad. Nat. Sci. Philadelphia, pp. 227-228.

- 1902. On the common brown bats of peninsular Florida and southern California. Proc. Acad. Nat. Sci. Philadelphia, pp. 618-619.
- SAFFORD, W. E. 1919. Natural history of Paradise Key and the nearby Everglades of Florida. Ann. Rept. Smithsonian Inst. for 1917, pp. 377-434, 64 pls. 32 text figs. Mammals discussed on pages 423-424.
- SANBORN, COLIN CAMPBELL. 1932. The bats of the genus *Eumops*. Journ. Mamm., vol. 13, no. 4, pp. 347-357.
- SAY, THOMAS. 1823. Account of an expedition from Pittsburgh to the Rocky Mountains, performed in the years 1819 and '20, under the command of Major Stephen H. Long. Compiled by Edwin James. 2 vols. Philadelphia.
- and George Ord. 1825. Description of a new species of Mammalia, whereon a genus is proposed to be founded. Journ. Acad. Nat. Sci. Philadelphia, vol. 4, pp. 352-355, figs. 5, 6.
- SHAMEL, H. HAROLD. 1931. Notes on the American bats of the genus *Tadarida*. No. 2862.—From the Proc. U. S. Nat. Mus., vol. 78, pp. 1-27.
- SHERMAN, H. B. 1928. A Florida record of *Sorex longirostris*. Journ. Mamm., vol. 9, no. 2, p. 148.
- 1929. Notes on some Florida mammals. Journ. Mamm., vol. 10, no. 3, pp. 258-259.
- 1930. Birth of the young of *Myotis austroriparius*. Journ. Mamm., vol. 11, no. 4, pp. 495-503, pl. 26.
- 1934. The occurrence of *Myotis grisescens* in Florida. Journ. Mamm., vol. 15, no. 2, pp. 156.
- SIMPSON, GEORGE GAYLORD. 1929. The extinct land mammals of Florida. Twentieth Ann. Rept. Fla. State Geol. Surv., pp. 229-280.
- STODDARD, HERBERT L. 1932. The bobwhite quail. Its habits, preservation and increase. Chas. Scribner's Sons, N. Y.
- THOMAS, OLDFIELD. 1898. Notes on various American mammals. Ann. and Mag. Nat. Hist., ser. 7, vol. 2, pp. 318-320.
- TRUE, FREDERICK W. 1884. A muskrat with a round tail. Science, vol. 4, p. 34.
- WAGNER, J. A. 1843. Wiegmann's Arch. f. Naturg., ix, vol. 2.

THE ANALYSIS OF PLANT ASH IN THE LIGHT OF THE LAW OF DEFINITE PROPORTIONS: AN APPARENTLY FORGOTTEN CHEMICAL PRINCIPLE

L. W. GADDUM
University of Florida

A SURVEY of the literature on the analysis of ashed plant material reveals some striking inconsistencies with the law of definite proportions. In some cases the discrepancy is far beyond any reasonable allowance for experimental error and suggests either an error in calculation from experimental data or a serious defect in the method of analysis.

The law of definite proportions demands that

$$\left\{ \begin{array}{l} \sum_i x_i = 100 \\ \sum_i \frac{v_i}{X_i} x_i = 0 \end{array} \right.$$

where x_i is the percentage of the element in the ash, X_i its atomic weight and v_i its valence. Hence, the percentages of elements present in a plant ash should satisfy these two simultaneous equations.

In general, analyses indicate that the main constituents of a plant ash are sodium, potassium, calcium, magnesium, phosphorus, sulfur, silicon, iron, chlorine, carbon and oxygen. Other elements are frequently present in rather small percentages but their rôle is insignificant in the discrepancies mentioned above.

Kelley and Cummins¹ analyzed the ash of Valencia orange leaves obtaining the following data:

(On the dry ash basis)

	<i>Percent</i>
sodium	0.78
potassium	6.40
calcium	31.40
magnesium	1.73
iron	0.15
phosphorus	0.86
sulfur	0.97
silicon	0.97
chlorine	0.95

Presumably the remainder of the ash consists primarily of (a) oxygen combined as phosphate, sulfate, and silicate, (b) oxygen combined as metallic oxide, and (c) carbonate. Obviously the oxygen in (a) is 5.37 percent therefore the equation shown above becomes

$$\left\{ \begin{array}{l} \frac{1}{30}(\% \text{CO}_3^-) + \frac{1}{8}(\% \text{O}^-) = 1.7 \\ (\% \text{CO}_3^-) + (\% \text{O}^-) = 50.4 \end{array} \right.$$

whence

$$\left\{ \begin{array}{l} (\% \text{CO}_3^-) = 50.7 \\ (\% \text{O}^-) = - .2 \text{ [practically zero].} \end{array} \right.$$

¹ Kelley, W. P., and Cummins, A. B., Composition of normal and mottled citrus leaves. Jour. Agr. Res. 20: 3: 161-191. 1920.

This result indicates that the data quoted above are at least consistent with the law of definite proportions. Moreover the results accord with preliminary results of Peterson² who showed that very little if any metallic oxide oxygen was present in citrus leaf ash, when ashed at 450° C.

On the other hand, as an example of data apparently inconsistent with the law of definite proportions, an analysis of cottonseed kernels recorded in the literature³ may be cited.

The report submits the following data. (On the dry crude ash basis)

	<i>Percent</i>
sodium	17.04
potassium	27.75
calcium	4.45
magnesium	9.05
iron	0.36
phosphorus	42.96

Since the sum is 101.61 percent, no place is left in the analysis for sulfur, silicon, carbon, and oxygen. If the data are substituted in the equations above

$$\left\{ \begin{array}{l} \frac{6}{32.06}(\%S) + \frac{4}{28.06}(\%Si) + \frac{4}{12}(\%C) - \frac{1}{8}(\%O) = -9.3 \\ (\%S) + (\%Si) + (\%C) + (\%O) = -1.6. \end{array} \right.$$

The crude ash probably contains sulfur, silicon and carbon in addition to the elements whose percentages are recorded. Neglecting these elements temporarily however, about 88.6 grams of oxygen per 100 grams of ash are required to combine with the phosphorus, since the phosphorus presumably exists as PO₄ radical. Thus the analysis would imply 190.2 percent of constituents in the ash. If one takes into consideration the sulfur, silicon and carbon which presumably are present in the ash, the discrepancy is greater.

The conclusion seems unavoidable that either an error was made in calculating the reported figures from laboratory data or the methods employed are in error by about 90 percent.

Similar examination of other data in the literature reported by other workers, reveals similar cases of inconsistency with the law of definite proportions. It is suggested that reports of analytical data on plant and other ashes be accompanied by a check with the law of definite proportions wherever possible.

² H. Peterson. Unpublished work, Dept. of Hort., Univ. of Florida Exp. Sta.

³ McHargue, J. S., Mineral constituents of the cotton plant. Jour. Am. Soc. Agron. 18: 12: 1076. 1926.

THE CELLULOSE OF SPANISH MOSS

L. E. WISE and A. MEER
Rollins College

THE EARLIEST recorded work on the chemistry of Spanish Moss (*Tillandsia usneoides*) was done in 1861 by Luca,¹ who found that the moss was high in ash. Spanish Moss is an epiphyte, that is, it derives all of its food from the air. For this reason the high content of ash appeared unusual.^{2,3} Wherry and Buchanan⁴ found that the ash contained silicon and iron, but gave no reason for their presence. Schorger,⁵ however, considers that all the inorganic matter is derived from dust carried by the wind and rain, and caught by the leaf scales which seem very well adapted for this purpose.

Spanish Moss has also been studied from the more practical standpoint of adapting it as a stock food.³ The botanical side has been thoroughly investigated by Billings⁶ and by Uphof.⁷ The process of retting the moss prior to its use in upholstery has been carefully investigated by Record.⁸ Uphof has described the fermentation that takes place during the retting process.

A rather thorough research of the carbohydrate constituents has been carried out by Schorger,⁵ who did not, however, actually work on the constitution of the cellulose of the moss. His investigation of the carbohydrate material showed the presence of galactan, araban, xylan, and cellulose. Among the non-carbohydrate constituents protein, chlorophyl, a caratinoid pigment, a sterol, and wax were found.

The object of this work was to investigate certain of the chemical properties of the cellulose contained in Spanish Moss, especially in their relation to those of cotton cellulose. The principal object was to learn whether the same chemical unit occurred in Spanish Moss as in the cotton cellulose macromolecule.

In this connection Cross and Bevan cellulose and alpha cellulose were isolated by methods in vogue in the U. S. Forest Products Laboratory,⁹ in the case of woods. The yields and properties of cellobiose octaacetate obtained by subjecting the moss cellulose to the acetolysis reaction were compared quantitatively with those obtained from cotton.

SOURCES OF CELLULOSE

As is commonly known cellulose is one of the most widely distributed of all organic materials. Its sole possible competitor is another complex polysaccharide, starch. Cellulose forms the principal skeletal substance of green plants, wood, straw and the like. Since carefully treated cotton is almost pure cellulose, it has been taken as the

standard for comparison with celluloses obtained from other sources. Industrially, the tendency has been to substitute wood cellulose for many products which had hitherto employed cotton. Other than cotton and wood, products from the stalks of flax, hemp and jute have been employed as textile fibers. All of these seem to contain a recurring-anhydro cellobiose unit or residue common to cotton. Some types of cellulose, however, are of doubtful chemical constitution. The polysaccharide isolated from *Posidonia australis*,¹⁰ a seed bearing sea plant, and lichenin,^{11,12,13} an important component of Iceland moss (*Cetraria islandica*) show only certain of the chemical properties of cellulose.

CHEMICAL CONSTITUTION OF CELLULOSE—THE RECURRING
"UNIT CELL" IN CELLULOSE (I. E.,
ANHYDROCELLOBIOSE)

Although the hydrolysis of cellulose to glucose has been known since 1819,¹⁴ its quantitative hydrolysis was first carefully carried out by Monier-Williams,¹⁵ who isolated nearly 91 percent of the theoretical amount of crystallized glucose according to the equation:

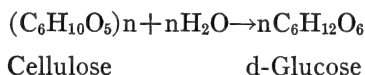

The above equation gives, however, only the starting point (cellulose) and the end product (d-glucose). Willstatter and Zechmeister¹⁶ have isolated several crystalline intermediates between cellulose and glucose. In order to gain some insight into the mechanism of the hydrolysis of cotton cellulose, a useful but limited picture of this stepwise hydrolysis¹⁷ may be given as follows:—

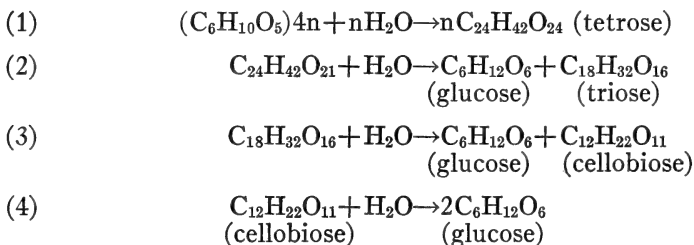

This, of course, is at best only schematic, since according to recent data, cellulose may have a molecular weight as high as 120,000 depending on the source and pretreatment,¹⁸ which would mean 750 glucose residues in the molecule.

☛ In connection with the problem of the constitution of cellulose, the acetolysis reaction has been of the greatest help. Acetolysis may be

defined as the rupture of a polysaccharide molecule with attendant acetylation of its degradation products.¹⁷ When the reaction is carried out on cellulose, cellobiose octaacetate is the principal product, although intermediate products, and the final product glucose pentaacetate may also be formed. It has thus been shown that the complex cellulose molecule consists of recurring "unit cells" of anhydrocellobiose. In its simplest terms the reaction may be given as follows:—

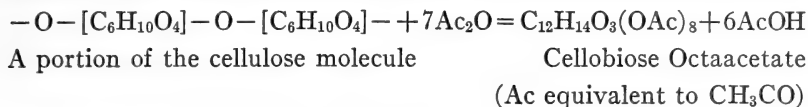

The problem of obtaining cellobiose or its derivative, the octaacetate, from cellulose is, therefore, directly connected with work concerning the constitution of the latter, the assumption being made that the acetolytic treatment causes no intramolecular rearrangements. To a certain extent there is a similarity between the acetolysis reaction and the hydrolysis of cellulose. In both cases a rupture of the polysaccharide molecule takes place, although in the latter case there is no acetylation, and the hydrolysis goes further to glucose.

Leaving out of consideration all of the stereo-chemical configurations of the "fragment," the anhydrocellobiose linkage in cellulose is represented below, x indicating the points at which this linkage is joined to similar neighboring linkages.

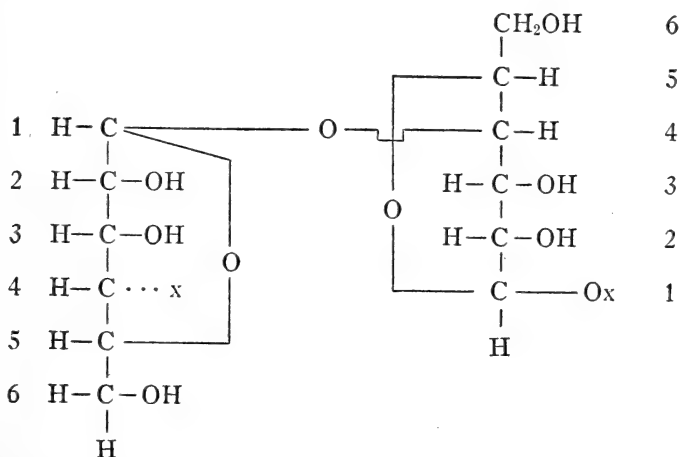

For each 6 carbon atoms there is an "amylenoxide" bridge (i.e., 1, 5). Also, there is a glucosidic (acetal) linkage between C atom No. 1 of one unit and C atom No. 4 of the neighboring unit. There is thus a succession of anhydroglucose units joined through oxygen bridges.

How many times this is repeated we do not know definitely. From present indications, however, in high-grade cotton this unit may be repeated, perhaps, 375 times.¹⁸

Haworth¹⁹ gives the formulation we have given above for cellulose in the form of long chains of heterocycles linked together by oxygen. The configuration of the groups is shown somewhat more clearly by means of a perspective construction, where the hydrogens and the hydroxyls are placed above or below the plane of the 6 atom ring depending on the stereochemical configuration.

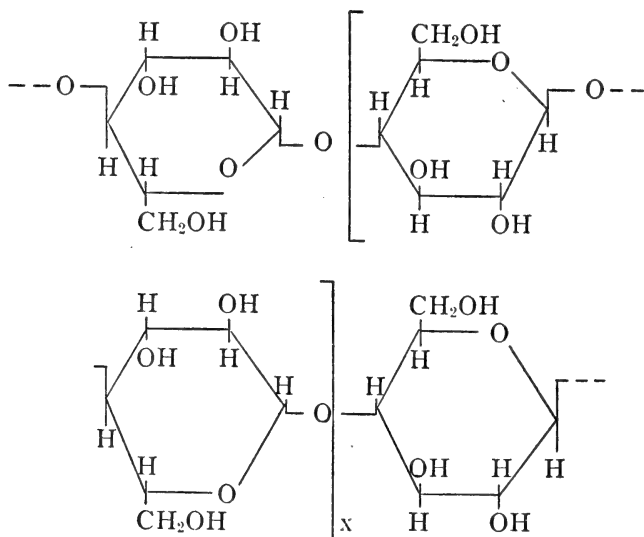

ISOLATION OF CELLULOSE

Prior to the isolation of cellulose, extraneous materials must be removed. The removal of such extraneous non-carbohydrate material is effected by the use of different solvents and is often difficult and tedious. In the case of woods the solvents vary in different laboratories, but may include almost any suitable organic liquid and water. The use of alkalis affects the cell wall components, but has little effect on cellulose.

CROSS AND BEVAN CELLULOSE

If the isolation of cellulose is simply for analytical purposes, the removal of lignin and other extraneous constituents from the extractive-free material is usually brought about by alternate treatment of the finely divided sample with chlorine and sodium sulphite by a purely empirical method. This cellulosic residue after chlorination is usually spoken of as "Cross and Bevan Cellulose" rather than

just cellulose.²⁰ It cannot be termed cellulose, for it may not be one individual resistant polysaccharide, but a mixture of several resistant polysaccharides. Some of these polysaccharides associated with cellulose in woody tissue have been loosely grouped together as "hemicellulose." They are non-fibrous, colloidal polysaccharides, which are usually soluble in NaOH solutions and hydrolized by dilute acids, in which the resistant cellulose is insoluble.

In the original method used by Cross and Bevan²¹ the chlorination treatments were long; ranging from 30 minutes for the first chlorination to 15 minutes for the last. Ritter²² has shown that these chlorination periods may be shortened to 3 minutes for the first chlorination, and, that even in this short period the same quantities of lignin and substances other than cellulose are removed. The cellulose thus isolated is in as pure form as when treated with chlorine gas for the longer periods. The Cross and Bevan method for the estimation of cellulose as modified by the U. S. Forests Products Laboratory⁹ is as follows:—

Approximately 2 grams of the air-dry extractive-free material are weighed in a tared alundum crucible contained in a weighing bottle and dried to constant weight in the air oven at 105° C., which usually requires about 3 hours. The crucible is placed near the bottle during the drying, after which it is returned to the stoppered bottle, is cooled in a desiccator, and is re-weighed to obtain the weight of oven-dry material. The crucible is then connected to the chlorination apparatus. The first chlorination treatment requires from 3 to 4 minutes, after which the crucible is removed from the apparatus and the material is washed with cold, distilled water, using suction. These washings are saved for subsequent determination of the HCl formed. The material is next washed with 50 cc. each of a 3 percent sulphurous acid solution, cold water, and a freshly prepared 2 percent sodium sulphite solution. The material is transferred to a 250 cc. Pyrex beaker with the aid of a pointed glass rod, and is treated with 100 cc. of a 2 percent solution of sodium sulphite. The last traces of the sample adhering to the bottom of the crucible are removed by means of suction. A rubber policeman drawn gently over the bottom of the crucible assists materially in loosening particles of the sample during the procedure. The beaker containing the sample is covered with a watch glass and is placed in a boiling water bath for 30 minutes. The fibers are again transferred to the alundum crucible and are washed with about 250 cc. of distilled water. This procedure is never sufficient to remove all of the lignin, so that the treatment with chlorine and subsequent treatments, as just outlined, are repeated until the fibers are practically a uniform white or, at least, show only a very faint tinge of color upon addition of the sodium

sulphite solution. The second and following treatments with chlorine should not require more than 1 or 2 minutes each.

After the lignin has been removed the fibers are thoroughly washed in an alundum crucible (porosity A. 98) successively with hot water, 10 percent acetic acid, 500 cc. hot water, 50 cc. of 95 percent alcohol and finally with 50 cc. of ether. The tared crucible and its contents are dried at 105° C., to constant weight in an air oven, which usually requires about 2½ hours.

The tared alundum crucible and its contents are again placed in the original stoppered washing bottle, are cooled in a desiccator over concentrated sulphuric acid, and are weighed.

ALPHA CELLULOSE

The Cross and Bevan residue when subjected to further purification, such as digestion with cold alkali and careful washing with water and acid, has been termed "alpha cellulose." The determination of the alpha cellulose obtained from plant material by the chlorination method is a measure of the resistance of the cellulose to the action of the 17.5 percent sodium hydroxide solution, which is known as Mercer's solution. The above strength of NaOH is most commonly used in determining the alpha content of a cellulose. The soluble portion removed from alpha cellulose may be further separated into two fractions, the one precipitated by acids and arbitrarily termed beta cellulose; the other remaining dissolved after such treatment and termed gamma cellulose. Naturally, the method is empirical.

ACETOLYSIS OF CELLULOSE

Acetylosis has already been defined as the rupture of a polysaccharide molecule with attendant acetylation of its degradation products.¹⁷ Repeated investigations have served to emphasize the importance of the acetolysis reaction when applied to cellulose.

When acetic anhydride mixed with sulphuric acid acts upon cellulose, a part of the cellulose is converted into the octaacetate of cellobiose. This is the chief product of the reaction.

The formation of cellobiose octaacetate has a diagnostic value in indicating the presence of cellulose, since cellobiose has not been obtained by the acetolysis of any other polysaccharides (e.g., starch, inulin, pentosans, etc.)

The formation of cellobiose octaacetate is, however, far from quantitative. Theoretically, 1 g. of cellulose would yield (if complete conversion could take place) 2.09 g. of cellobiose octaacetate. Ost²³ obtained 37.7 percent and Madsen²⁴ as much as 43 percent of the theoretical amount of cellobiose octaacetate. Hess²⁵ has reported 50

percent of the theoretical amount, but Spencer²⁶ was unable to confirm this.

SPENCER'S METHOD OF ACETOLYSIS

Three factors:—concentration of sulphuric acid, temperature, and duration of the acetolysis reaction, influence, to a great extent, the yields of the octaacetate. With the purpose of increasing the yields, Spencer has investigated the most favorable conditions under which the reaction proceeds. Highest yields were obtained at a temperature of 50.4° C., using 0.2 cc. concentrated sulphuric acid, and 8 cc. of acetic anhydride (double distilled), which were allowed to react on 2 g. of purified cotton cellulose for a duration of 14 days. Of nine determinations an average yield of 42.3 percent of the theoretical was obtained. The maximum was 46.5 percent of the theoretical yield. The method is given in detail in the experimental portion of this paper.

Comparative data on yields of cellobiose octaacetate from cotton and from other sources prove that those from cotton are consistently higher. As has been pointed out by Wise and Russell,^{22a} some of the original cellulose units have been oxidized and others, no doubt, hydrolyzed during the more or less drastic treatment used in the removal of lignin. Those cells of the molecule in which alcoholic hydroxyl groups have been oxidized would not yield cellobiose octaacetate.

It may be mentioned in passing that cellobiose prepared from cellobiose octaacetate is used in the field of bacteriology.²⁷ A new method for the production of cellobiose has been devised by the New York State College of Forestry.²⁸

EXPERIMENTAL PART

DATA ON ORIGINAL DRY MOSS

The moss used in all of these investigations was collected from two trees on the Rollins College campus in Winter Park, Fla. After it was cleaned very carefully of foreign material, it was snipped with shears into particles from 1 cm. to 3 cm. in length. The moisture varied between 40.0 percent and 62.2 percent on samples collected at different periods. The ash content based on the average analysis of two samples and calculated on an oven-dry basis gave 3.40 percent.

FRACTIONS OF MOSS SOLUBLE IN ORGANIC SOLVENTS

The moss was treated successively with ether, chloroform, alcohol and hot water for the removal of non-polysaccharide constituents. The oven-dry material was removed to a mercerized cotton bag and extracted for nine hours in a Soxhlet with ether. 4.08 percent of the

moss was soluble in the ether. The extract was yellowish green in color and had a characteristic odor. The chloroform extracted 1.04 percent of the moss and was yellow in color. The alcohol extract was a brown, hard, dark substance, and varnish-like in appearance on evaporation. The alcohol removed 10.7 percent of the non-polysaccharide material. 14.0 percent was soluble in hot water. A total of 29.8 percent of the oven-dry moss was soluble in the above solvents. The constituents of some of these extractives were determined by Schorger.⁵ Table I summarizes percentages of material soluble in each of the three organic solvents and in hot water in the case of two samples.

TABLE I
EXTRACTIVES FROM ORIGINAL MOSS

Grams of oven-dry moss taken	Ether sol.	Chloroform sol.	Alcohol sol.	Hot Water sol.
1.1507	4.28%	1.16%	11.6%	14.0%
1.3657	4.07%	.92%	9.8%	14.0%

ISOLATION OF CELLULOSE FROM ABOVE
EXTRACTED MATERIAL

CROSS AND BEVAN CELLULOSE

Cross and Bevan Cellulose was obtained by the method outlined by the U. S. Forest Products Laboratory, with only a few minor modifications.

Approximately 2 grams of air-dry moss contained in a weighing bottle were dried in an oven at 105° C. After constant weight had been reached, the bottle was stoppered, cooled, and reweighed to obtain the weight of oven-dry material. The material was removed to a Gooch crucible and thoroughly moistened with distilled water. The process of chlorination was carried out by passing a stream of washed chlorine from a cylinder over moist moss contained in a 1 liter wide-mouth bottle, which was provided with a two-hole rubber stopper, and an inlet and an outlet tube, so that the material remained in a slowly moving atmosphere of chlorine during each period. The chlorination periods were from 3-4 minutes, after which the crucible was removed from the bottle and the material washed with cold, distilled water, using suction. The material was next washed successively with 50 cc. each of 3 percent sulphurous acid solution, cold water, and a freshly prepared 3 percent sodium sulphite solution. The material was then transferred to a 250 cc. Pyrex beaker and was treated with 100 cc. of a 3 percent solution of sodium sulphite. The mixture was heated in a water bath for 45 minutes. At the end of this

period the residue was filtered off and washed with about 250 cc. distilled water.

This treatment was continued until the material was entirely white or showed only a slight tinge of pink upon addition of sodium sulphite solution. After the lignin had been removed, the fibers were thoroughly washed in the Gooch crucible, using a mercerized cotton filter. The successive washings were with hot water, 10 percent acetic acid, 500 cc. hot water, 50 cc. 95 percent alcohol and finally with 50 cc. ether. The tared crucible and its contents were dried at 105° C., to constant weight.

Five to six chlorinations were necessary before bleaching was completely effective. Three to four minute periods were used for the first

TABLE II
YIELDS OF CROSS AND BEVAN CELLULOSE FROM EXTRACTIVE-FREE OVEN-DRY MOSS

Oven-dry extracted moss	Cross and Bevan Cellulose	
g.	g.	%
1.5176	.7943	54.44
1.7136	.9086	53.0
1.2552	.7132	56.8
13.6418	6.960	51.3
15.6675	9.2680	59.1
1.8086	1.1520	60.3

chlorination, and periods of 1-2 minutes for the second and subsequent chlorinations. During the first three chlorinating periods the material became a bright orange, but with later chlorinations the sample finally remained white, or very pale yellow in the presence of chlorine. The addition of sulphurous acid invariably caused the material to become lighter, thus having a bleaching effect in addition to its action as anti-chlor. On addition of the sodium sulphite solution following the first four chlorinations, the solution became dark red and, finally, almost colorless after the fifth and sixth chlorination, so that by thoroughly washing, a white product was obtained. 2 percent sodium sulphite solution was used for all isolations of cellulose, although Schorger states that the chlorinated material was scarcely affected by a 2 percent solution of sodium sulphite.⁵

The cellulose content of the average of 3 determinations of approximately 1.5 grams of oven-dry material gave 54.7 percent. This represented 41.4 percent of the original oven-dry moss. A larger sample was then taken, in order to obtain a sufficient quantity of the purified cellulose for further study. 15.7 grams of the extractive-free

oven-dry moss gave 9.3 grams of the Cross and Bevan cellulose, or a yield of 59.1 percent.

In all filtrations of the larger sample a Büchner funnel with a mercerized cotton filter was used.

ALPHA CELLULOSE

The total cellulose was converted to the so-called alpha cellulose. The following method⁹ was the one employed:—

A 1 gram sample of oven-dry alpha cellulose was weighed into a beaker and triturated with 25 cc. of 17.5 percent sodium hydroxide solution until the mass was homogeneous, and was then allowed to stand for 30 minutes. The contents of the beaker were filtered off by suction, until the material was sucked practically dry. It was washed with 50 cc. of 4 per cent sodium hydroxide, and then with approximately 300 cc. of cold distilled water. The alpha cellulose was then treated with 75 cc. hot 10 percent acetic acid, again washed with 300 cc. hot distilled water, dried in the oven to constant weight, and weighed as alpha cellulose. The cellulose obtained in this manner invariably turned grey upon drying. A 1.2 gram sample of moss cellulose gave 70.2 percent alpha cellulose. Carefully dried cotton gave in a comparative experiment 98.6 percent alpha cellulose.

DETERMINATION OF CARBON AND HYDROGEN

The results of two combustions, which were run on samples of Spanish Moss alpha cellulose, are shown in the following table.

TABLE III
DETERMINATION OF CARBON AND HYDROGEN IN ALPHA
CELLULOSE (SPANISH MOSS)

Substance	Percent Carbon		Percent Hydrogen	
	Found	Theory	Found	Theory
Sample #1	44.34	44.44	6.10	6.17
Sample #2	44.39	44.44	6.12	6.17

ACETOLYSIS OF CELLULOSE

METHOD

The technic of Spencer²⁶ was followed very carefully in carrying out the acetolysis reaction. Parallel and comparative experiments were made using samples of surgical cotton and normal cellulose isolated from Spanish Moss. The method was the following:—

8 cc. double distilled acetic anhydride (b.p. 134–139° C.) was added from a burette into an eight-inch Pyrex test tube. This was immediately stoppered and placed in an ice bath at 0° C. When the tempera-

ture of the anhydride had reached that of the bath, 0.2 cc. of sulphuric acid (sp. gr. 1.84) was carefully added, so as to avoid any appreciable mixing or interaction of the two liquids. After the contents had been brought to the temperature of the ice-bath, the tube was carefully shaken. During the mixing of the two liquids a maximum rise of 10° C. took place. The cellulose was then added to the contents of the test tube, and kneaded into the mixture with a glass rod, so that all the fibers came into intimate contact with the liquid. The entire contents of the test tube remained for 30 minutes in the ice-bath, after which it was transferred to a water bath and remained for 14 days at a constant temperature of 50.4° C. ($\pm 0.5^{\circ}$). After 50–60 hours a crystalline mass gradually separated out. After 14 days the tube was removed, 10 cc. of acetic acid were added to the paste and the contents were thoroughly mixed, and poured into 500–750 cc. cold distilled water. The resulting precipitate was allowed to stand in water at 15° C., for at least 1 hour. It was then filtered off on a Büchner funnel, using mercerized cotton cloth as the filtering medium, and washed with water until only a trace of acid was present. The precipitate was air-dried and then extracted with 150 cc. 95 percent alcohol at the boiling point. The solution was filtered and then cooled to 0° C., to permit crystallization. After this was complete, the crystals were filtered on a weighed Gooch crucible, dried and weighed. These fine, readily felting white needles were cellobiose octaacetate, as shown by subsequent examination.

COMPARATIVE YIELDS OF CELLOBIOSE OCTAACETATE

The acetolysis reaction was carried out on 3 samples of cotton and on 4 samples of alpha cellulose from Spanish Moss. The highest yield of the cellobiose octaacetate from cotton was 43.67 percent. Two other samples gave 39.35 percent and 36.9 percent of the theoretical yield. Four samples of alpha cellulose isolated from Spanish Moss gave 27.0–30.9 percent of the theoretical yields of cellobiose octaacetate. The moss cellulose being in a more compact form and exposing less surface to the liquid was not peptized by the acetolysis mixture as readily as was cotton. As far as it was possible, nearly identical conditions were maintained in carrying out the acetolysis experiments. The conditions under which the acetolysis reaction takes place must be carefully controlled. Spencer has shown that even slight deviations from the empirical method will lower the yields of the octaacetate considerably. The difference in the quantitative yields of the above should, therefore, be attributed to unavoidable variations in technic of acetolysis of the cellulose.

The identification of cellobiose octaacetate is given in the following sections.

TABLE IV
COMPARISON OF YIELDS OF CELLOBIOSE OCTAACETATE
OBTAINED FROM COTTON AND SPANISH MOSS

	g. Cotton	g. Spanish Moss
Alpha cellulose after treatment of original total cellulose with 17.5% NaOH, taken for acetolysis.....	(1) 1.9997 (2) 1.9918 (3) 1.9901	(1) 1.9997 (2) 1.9909 (3) 1.9982 (4) 2.0470
Cellobiose Octaacetate obtained.....	(1) 1.5743 (2) 1.7477 (3) 1.4754	(1) 1.1967 (2) 1.0806 (3) 1.0810 (4) 1.2326
Percentage of theoretical yield of octaacetate calculated from normal cellulose content.....	(1) 39.35% (2) 43.67% (3) 36.87%	(1) 28.7% (2) 27.1% (3) 27.0% (4) 30.9%

MELTING POINT DETERMINATIONS

Data of melting point determinations of cellobiose octaacetate obtained from cotton and that obtained from moss cellulose, both alone and in admixtures with each other, are shown in Table V.

TABLE V
MELTING POINT DETERMINATION ON SAMPLES
OF CELLOBIOSE OCTAACETATE

Melting Point of crystalline product from cotton	Melting Point of crystalline product from Moss	Melting Point of crystalline product from 50-50 mixture
222.5-223.0 C. (uncorr.)	223.5-224.0 C.	223.0-224.0 C.
222.5-223.0 C.	223.5-224.0 C.	223.0-224.0 C.

OPTICAL ROTATION

2.3958 grams of cellobiose octaacetate, which had been prepared from purified moss cellulose, and which had been purified by recrystallization with Norite from hot alcohol, was dissolved in 50 cc. of chloroform at 25° C. This represents a concentration of 4.7916 grams per 100 cc. of solution. The angular rotation at 25° was 3.97°, which gives a specific rotation, $[\alpha]_D^{25} + 41.4^\circ$. A sample of cellobiose octaacetate prepared from purified cotton cellulose gave a specific rotation, $[\alpha]_D^{25} + 41.3^\circ$. Spencer³⁰ gives $[\alpha]_D^{25} + 41^\circ$ to $[\alpha]_D^{25} + 41.8^\circ$ for cellobiose octaacetate.

DETERMINATION OF CARBON AND HYDROGEN

Two combustions were made on the cellobiose octaacetate prepared from the purified Spanish Moss cellulose. The results of the experiments are shown in Table VI.

TABLE VI
DETERMINATION OF PERCENT CARBON AND HYDROGEN
IN CELLOBIOSE OCTAACETATE

	Percent Carbon		Percent Hydrogen	
	Found	Theory	Found	Theory
Sample #1	49.59%	49.51	5.64	5.54
Sample #2	49.56%	49.51	5.39	5.54

Briefly summarizing these data:—

1. The maximum yield of cellobiose octaacetate obtained from purified cotton cellulose was 43.67 percent of the theoretical yield.
2. The maximum yield of cellobiose octaacetate obtained from purified moss cellulose was 30.90 percent of the theoretical yield.
3. The melting points of samples of cellobiose octaacetate prepared from purified cotton and moss cellulose, as well as mixed melting points, were almost identical.
4. Identical weights of cellobiose octaacetate obtained from purified samples of cotton and moss cellulose gave the same specific rotation (within the experimental error).
5. On combustion the octaacetate prepared from purified moss cellulose gave 49.57 percent C and 5.52 percent H (which compares favorably with the theory of 49.51 percent C and 5.54 percent H).

SUMMARY AND CONCLUSIONS

1. Spanish Moss (*Tillandsia usneoides*) contains approximately 59 percent Cross and Bevan cellulose on the basis of the extracted material or 45 percent on the basis of the original material (calculated on an oven-dry basis).
2. Methods for removing the foreign extractives are outlined.
3. The Cross and Bevan residue extracted from Spanish Moss, when treated with 17.5 percent NaOH, gave approximately 70 percent alpha cellulose.
4. The alpha cellulose upon combustion gives 44.37 percent carbon and 6.11 hydrogen.
5. The anhydrocellobiose linkage in purified moss cellulose occurs to the extent of, at least, 30.9 percent.
6. Since the acetolysis mixture is known to destroy appreciable amounts of cellobiose during the acetolysis, this is a minimal figure.

7. Based on the acetolysis reaction, it is evident that Spanish Moss cellulose and cotton cellulose definitely contain the same "structural unit cell," i.e., anhydrocellobiose, and that the chemical architecture of Spanish Moss cellulose and of cotton cellulose are similar.

8. These findings, of course, give no evidence regarding the relative dimensions of the cotton and moss cellulose molecules.

BIBLIOGRAPHY

1. Luca, *Compt. rend.* 52, 244 (1861) through Schorger, "Some Constituents of Spanish Moss," *J. Ind. Eng. Chem.*, 19, 409 (1927).
2. Pickell, *Fla. Expt. Sta., Bull.*, 11, (1890), 12 (1891).
3. Halligan, *J. Ind. Eng. Chem.*, 1, 206, (1919).
4. Wherry and Buchanan, *Science*, 61, XLV (1925).
5. Schorger, *J. Ind. Eng. Chem.*, 19, 409 (1927).
6. Billings, *Botan. Gaz.*, 38, 99 (1904).
7. Uphof, *Tidschrift voor Economische Geographie*, May 157 (1932).
8. Record, *Sci. Am.*, (1916) 58.
9. Bull., *Forest Products Lab.*, Methods No. 9-45, Aug. (1928).
10. Earl, *H. Chem. Soc.*, 125, 1322 (1924).
11. Berzelius, *Ann.* 90, 277 (1814).
12. Ott, *Helvetica Chim. Acta*, 9, 31 (1925).
13. Hess, "Die Chemie der Zellulose und ihrer Begleiter" p. 91 (1928) through Wise, *Cellulose* 1, 1 Feb. (1930).
14. Bracconot, H. Gay Lussac's *Ann. Chemie*, Oct. 1819.
15. Monier-Williams, *J. Chem. Soc.* 119, 804 (1921).
16. Willstätter and Zechmeister, *Ber.*, 62, 722 (1929).
17. Wise, "The Chemistry of the Polysaccharides," A Lecture delivered at the College of Agriculture of Rutgers University, March 21, 1930.
18. H. Staudinger, *Chem-Ztg.* 58, 145 (1934) through *Papier-Fabr. Abstracts* 32, No. 40 (1934).
19. W. N. Haworth, "Die Konstitution der Kohlenhydrate," Verlag Th. Steinkopff, 1932.
20. Wise, *Cellulose*, 1, 1, Feb. (1930).
21. Cross and Bevan, *J. Chem. Soc.* 38, 666A (1880). *Chem. News* 42, 77-91 (1880) *J. Chem. Soc.* 55, 199 (1889).
22. G. J. Ritter, *Ind. Eng. Chem.* 16, 947 (1924).
23. Ost, *Ann.*, 398, 335, (1913).
24. Madsen, *Dissertation*, (Hanover, 1917).
25. Hess and Friese, *Ann.*, 456, 38 (1927).
26. Spencer, *Cellulosechemie*, 10, 61 (1929).
27. Jones and Wise, *Journal of Bacteriology*, 11, 359 (1925).
28. *J. Am. Chem. Soc.*, 49, 2822, (1927).

ABSTRACTS

APPLICATION OF HELLEY'S THEOREM TO SEQUENCES OF JORDAN CURVES

DONALD FAULKNER
Stetson University

HELLEY'S theorem states that an everywhere convergent subsequence can be chosen from a uniformly bounded sequence of monotonic functions. An elementary proof is given.

Jordan arcs, distance of two arcs, and convergence of sequences of arcs in the sense of Jordan are next defined and the characteristics of monotonic transformations on Jordan arcs are discussed. These characteristics include the possession of limits from both sides and continuity at a point. An application of Helley's theorem to Jordan arcs is then stated thus:

Let the sequence of Jordan arcs Γ_n^* converge to the Jordan arc Γ^* and let the monotonic transformations $P_n^* = T_n(P)$ carry Γ into a set on Γ^* . Then, $T_n(P)$ contains everywhere on Γ convergent subsequences, and the limit transformation is again monotonic and carries Γ into a set on Γ^* .

The Jordan closed curve is defined as the topological image of the unit circle and the theorem on the monotonic transformation of Jordan arcs is used to prove the general theorem:

Let the monotonic transformation $P_n^* = T_n(P)$ carry the Jordan curve Γ into a set on the Jordan curve Γ_n^* , and the three distinct, fixed points, A, B, C , on into three distinct fixed points on $\Gamma_n^*, A_n^*, B_n^*, C_n^*$. Also, let Γ_n^* converge to Γ in the sense of Frechet, and $A_n^* \rightarrow A^*, B_n^* \rightarrow B^*, C_n^* \rightarrow C^*$. Then from the sequence $T_n(P)$ we may select everywhere on Γ , convergent subsequences $T_{nk}(P)$. The limit transformation $T(P)$ is monotonic and carries Γ into a set on Γ^* , with $A \rightarrow A^*, B \rightarrow B^*$, and $C \rightarrow C^*$.

THE METHODS OF MULTIPLE FACTOR ANALYSIS

CHARLES I. MOSIER
University of Florida

A BRIEF discussion of the historical development of the methods of multiple factor analysis is followed by a concrete example of its application, an indication of the possible range of application to data outside the field of psychology and a geometrical interpretation of the problem. Then is presented in terms of matrix algebra the development of the fundamental factor theorem, and certain other related theorems, establishing the possibility of the methods, the conditions under which the proof holds, and the postulational basis. This is followed by a description of the actual working of the method.

A QUANTITATIVE METHOD FOR THE DETERMINATION OF MINUTE AMOUNTS OF COPPER IN BIOLOGICAL MATERIALS

L. L. RUSOFF AND L. W. GADDUM
University of Florida

"SALT SICK," a naturally occurring nutritional anemia, is caused by a deficiency of iron and copper in the forages grown on certain soil types along the eastern coast of the United States and Canada. Nutritional anemia due to a lack of iron in soil and forage also occurs in New Zealand, Kenya Colony, the Scottish border and on King's Island, Tasmania.

Correction and prevention of nutritional anemia was accomplished by the use of iron and a trace of copper in Florida. In order to determine the significance of copper for the body, the copper content of organs and tissues must be studied.

A critical examination of the common methods for copper analysis showed each to have at least one of the following faults:

1. There is incomplete recovery of copper when it is precipitated as copper sulfide or electrolyzed out of solution.
2. The removal of metals, especially iron, carries down some copper when they are precipitated out.
3. The colors produced with minute amounts of copper are very difficult to compare and do not follow Beer's Law.
4. The alkalinity or acidity of the solution changes the concentration of the color in the organic solvent.
5. There is incomplete extraction of color with the organic solvent. The color can be intensified by aliquot extractions in place of the usual total extraction. The time and vigor of shaking also change the intensity of the color and produce a turbidity.
6. The main objection to all the methods is contamination with copper from reagents and apparatus employed.

Since quantitative spectroscopic methods avoid these faults, and contamination from copper is reduced, the authors turned to the development of such a method.

Briefly, the spectroscopic method employed is as follows: A set of standards of pure chemicals is made up with definite amounts of copper. Identical amounts of an internal standard are added to each standard copper solution. Spectrograms are taken. The ratio of densities of the spectral lines of the internal standard and the copper are measured by means of a photometer. By plotting the ratio against percentage of copper, a calibration curve is obtained, which is then available for use in determining the amount of copper in an unknown sample.

It was necessary that the water and reagents used be purified, in order to determine copper in as small amounts as "parts per million." Redistilling water through an acid leached glass still twice, removed copper to less than 0.5 p.p.m. The salts were purified by recrystallizing eight times from the specially-distilled water and in leached containers, this final product also containing less than 0.5 p.p.m. of copper. These are the purest chemicals yet examined critically by the authors, as far as copper is concerned.

A purified base was made according to the composition of an animal ash, using cadmium and silver as internal standards. The calibration curve is underway.

RESULTS OF SOME FURTHER STUDIES OF THE DETERMINATION OF ZINC

L. H. ROGERS AND O. E. GALL
University of Florida

IT HAS BEEN found that the spectrographic microdetermination of zinc has a probable error of less than 10% of the mean.

Comparison of analyses for zinc by this method with analyses by a chemical method (Hibbard, *Ind. & Eng. Chemistry Analytical Edition*, 6, 423 (1934)) show excellent agreement in some cases and wide deviations in other cases.

(Complete results of this study appear in the January, 1937 issue of *Industrial & Engineering Chemistry, Analytical Edition*).

ABSORPTION SPECTROPHOTOMETRY AND ITS APPLICATIONS

L. H. ROGERS
University of Florida

A REVIEW of the technique and apparatus required for quantitative absorption spectrophotometry in the visible and ultraviolet. An example of its usefulness for the determination of Vitamin C in citrus juices is cited, and other biochemical and industrial uses mentioned.

AN APPLICATION OF INFRA-RED SPECTROSCOPY TO RUBBER CHEMISTRY

DUDLEY WILLIAMS
University of Florida

THE APPLICABILITY of infrared methods to some problems arising in the chemistry of rubber has been demonstrated. The spectra of isoprene, styrene, polymerized butadiene, and several types of rubber have been studied and certain variations in the 5.5μ - 6.5μ regions are attributed to changes occurring during the processes of polymerization. The effects of vulcanization also appear in the spectra of the rubber samples. The methods of infrared analysis do not necessitate the use of solutions of rubber compounds in carbon tetrachloride or carbon disulphide as in the case of previous Raman work.

RAMAN SPECTRA OF ACETONE-WATER SOLUTIONS

R. C. WILLIAMSON
University of Florida

SOME preliminary results are presented showing changes in frequencies of certain modes of vibration of the acetone molecules in acetone-water solutions. The mode of vibration (1712 cm.^{-1}) attributed to the $C=O$ bond, decreased in frequency with increasing water content, approaching a limiting wave number for infinite dilution of approximately 1697 cm.^{-1} . The vibration (788 cm.^{-1}) characteristic of the $C-C$ bond, increased in frequency to a wave number of 795 cm.^{-1} under the same conditions. Other frequencies gave indications of small changes too uncertain to record.

SOME RECENT DEVELOPMENTS IN HIGH-FIDELITY SOUND REPRODUCTION

ROBERT I. ALLEN
Stetson University

THE PAST decade has been epochal in the history of sound reproduction. Prior to the year 1926, due to mechanical limitations, it was impossible to record or transmit a wider frequency range than 350-3000 cycles/sec. Hence the quality of the resulting sound was greatly impaired.

With the advent (in 1926) of the electrical method of recording, the range of frequencies was extended from about three octaves to about six. In this method: (a) a microphone replaced the old acoustical horn; (b) a powerful vacuum-tube amplifier was used to boost the intensity of the resulting electrical vibrations; (c) an electromagnetically operated cutting head replaced the mechanically-operated stylus.

The climax to this development came in 1932 when certain further refinements were effected. In the spring of 1933 the Bell Telephone Co. demonstrated before the American Academy of Sciences the reproduction of all frequencies of orchestral music (from 40-15,000 cycles/sec.); and, even more remarkable, presented this music in its normal auditory or spatial perspective.

Several important factors contributing to this phenomenal development are:

(1) Development and use of the cathode-ray oscillograph—a device for accurately graphing the “wave form” of any sound.

(2) Use of certain electrical networks, called “Filters” (consisting of an arrangement of condensers and inductance coils), by means of which any desired group or band of frequencies may be isolated from the most complex combination of tones.

(3) Development of ultra-high permeability magnetic core materials (such as: “hypernick,” “permalloy,” etc.) for use in the audio transformers of amplifiers, resulting in decreased tendencies toward core saturation and distortion of tone.

(4) Improvements in the construction of microphones, phonographic pickups, and speakers, utilizing materials having greater efficiency in converting electrical vibrations into mechanical (or vice versa). Rochelle Salt Crystals deserve special mention as having remarkable properties for such a purpose.

[EDITOR'S NOTE: In the original discussion, from which these notes are abstracted, the author interspersed a number of demonstrations which employed the following equipment: a high-fidelity vacuum-tube amplifier, a crystal phonographic pickup, a crystal microphone, a crystal speaker, a cathode-ray oscillograph, a “highpass” filter, a “low-pass” filter, several phonographic recordings (both acoustical and electrical types), several types of audio transformers, a vacuum-tube oscillator, and a chart showing the three characteristics of musical sound. The following notes refer to several of the demonstrations included.]

(A) The effect upon the pitch quality and of a single recorded tone, played successively by a piano, a cello and a French horn, and reproduced under various conditions of “filtering,” showed: (a) as more and more of the harmonics were eliminated the quality of the three instruments became more and more indistinguishable, whereas the pitch remained unchanged; (b) as more and more of the lower frequencies (including the fundamental) were eliminated the intensity diminished greatly, the pitch remained unchanged (being supplied subjectively by the ear), and the quality changed slightly.

Thus was emphasized how greatly the "quality" of sound depends upon the presence of the higher frequencies or harmonics.

(B) An "electrical recording" of Caruso's voice (the great tenor having died five years before the advent of the electrical method of recording) was played through the high-fidelity amplifier. This brilliant recording was obtained in the following ingenious manner: a stamping of the original (acoustical) recording, upon a disc made of smooth, scratch-free, material, served as the basis. While this record was being reproduced and fed into the new recorder, a new orchestral accompaniment was synchronized with Caruso's singing. Thus was supplied the lower tones and a richer orchestration—both missing in the original recording. To provide the missing "highs," a special "high-pass" filter system extracted the feeble overtones (which were present only 5 or 10% of their normal strength) and a separate vacuum-tube amplifier boosted them back to their proper proportions.

THE INTERRELATION OF MOTOR ABILITIES

P. F. FINNER

Florida State College for Women

THE EASY generalization that an individual is "fast" or "graceful" in his movements—that all performances of a person tend to be alike—is undergoing critical study. Some aspects of simple motor responses such as strength and speed seem to characterize all muscles of an individual. Other performances again are highly specific to certain musculatures.

An experiment with 100 subjects each of whom was tested for 300 trials in different tapping movements will be reported. It appears that, within a limited range, the muscles tend to perform at similar rates. Musculatures that have been practiced tend to maintain a uniform rate; muscles in new combinations tend to be unique in the performance and to change over a period of time.

EFFECT OF A LACK OF VITAMIN A ON THE BLOOD PICTURE OF RATS AND ADULT HUMANS

O. D. ABBOTT and C. F. AHMANN

University of Florida

CHANGES occurred in the leucocytes of rats fed for six to twelve months on diets low in vitamin A. The most significant ones were a decrease in the polymorphic nuclears, an increase in large lymphocytes and in juvenile forms. The presence of these immature cells such as myelocytes, myeloblasts and stabs indicated exhaustion of certain hematopoietic tissues. If vitamin A were not given at this time, the animals died. Death was due usually to respiratory diseases as xerophthalmia was present in only a few cases.

In coöperation with several hospitals a study was made of the blood picture of a number of malnourished humans. The most significant changes in the blood again were found in the ratio of the large to small lymphocytes and the presence of degenerate and immature forms.

The changes in the blood picture offer possibilities for use in diagnosing avitaminosis A in adult humans.

THE EFFECT OF CERTAIN ENVIRONMENTAL FACTORS ON THE DEVELOPMENT OF COTTON SEED, GERMINATING ABILITY, AND RESULTANT YIELD OF COTTON

W. A. CARVER
University of Florida

THE EFFECTS of the place of origin of seed, of plant nutrients, and of soil moisture were studied by the Florida Agricultural Experiment Station.

The Florida grown cotton seed used in the place-of-origin test were secured each year from the varieties in the variety trials. The out-of-state seed, or the seed grown by the originator during the previous year, were planted adjoining the Florida-grown seed of the same variety. A total of seventeen different varieties were tested during five seasons, 1928, 1930, 1931, 1932, and 1933. The varieties were found to differ in their reaction to Florida conditions. When the yield of all varieties are averaged, the out-of-state seed excelled by 56 pounds of seed cotton per acre. This difference is significant, the odds being 25.3:1. Out-of-state seed also germinated 10 per cent higher.

Observations on the effects of organic nitrogen or of green manure on the production of viable cotton seed were made at Gainesville in 1928 and 1929 when cotton was planted following heavy crops of *Crotalaria*, which were plowed under. The cotton seed produced under these conditions germinated 36 and 22 percent lower for the two years than did seed of the same varieties grown out of the state. The corresponding yields were 11 and 13 percent lower. In 1932 at Quincy, cotton was planted on soil following corn and peanuts (planted in alternate rows) and received fertilizer having various ratios of phosphoric acid, nitrogen, and potash. The different fertilizer treatments had no appreciable influence on the germinating ability of the resulting seed crop. On the other hand, the germination from seed produced in rows following corn averaged 14.6 percent higher than seed produced in rows following peanuts. The seed were also heavier following corn and had a lower moisture content.

In 1932, a moisture control experiment was conducted with cotton. The plants were carried in four gallon stoneware pots and kept in the open, the soil being protected from rainwater by white oil cloth. The different percentages of soil moisture saturation used were 50, 42, 34, 26, and 18. There were three jars of each moisture content. The wettest series of jars produced the smallest number of mature seed per boll, the highest percentage of immature seed, largest yield of bolls per plant, and the longest lint. The germination percentages shown by the seed grown at different soil moisture saturations reading from the wettest to the driest series were: 77, 64, 90, 93, and 92.

ORGANOGRAPHY OF SIXTEEN MILLIMETER *AMEIURUS*

NELLE CAMPBELL
Stetson University

1. The left posterior cardinal vein of *Ameiurus* arises from the right posterior cardinal by a sinus-like isthmus in the anterior portion of the kidney.
2. The subclavian veins enter the sinus venosus on the ventral surface, anterior to the position where the common cardinals enter.
3. In the sixteen millimeter stage the pneumatic vein and the transverse stem of the

right anterior intercostal veins enter the hepatic portal by a common stem with several intestinal and gastric veins. This common vein enters the portal in the pancreas just anterior to the point where the bile duct enters the intestine.

4. In the sixteen millimeter stage, the first pair of intercostal arteries send a branch to the head kidney and another branch dorsally and posteriorly. The second pair of intercostal arteries send a branch dorsally and a branch to the pectoral girdle. The subclavian in the adult seems to have developed from a fusion of portions of these two arteries, and it supplies the head kidney, pectoral girdle and fin, and the dorsal and lateral musculature.

5. In the sixteen millimeter stage the genital artery terminates in branches to the rectum.

6. The pneumatic duct is open in the sixteen millimeter, twenty millimeter, twenty-three millimeter, thirty-three millimeter, and adult stages.

7. The head kidney is probably functional in early embryonic stages, for in the sixteen millimeter, twenty millimeter, twenty-three millimeter stages there are present in the head kidney Malpighian corpuscles and renal tubules. There are also two connecting ducts which follow the two posterior cardinals from the head kidney to the kidney proper.

8. The pancreas is a separate organ in the sixteen millimeter stage through the thirty-three millimeter stage; in the adult, the pancreatic tissue is not massed together in lobes, but rather follows the blood vessels. In the sixteen millimeter stage there is a pancreatic duct which enters the intestine just posterior to the entrance of the bile duct into the intestine. In all stages studied the pancreatic tissue follows the branches of the hepatic portal into the liver, but only in the adult does the pancreatic tissue follow the blood vessels into the spleen.

INHERITANCE OF REST PERIOD IN PEANUT SEEDS

FRED H. HULL

University of Florida

DELAYED germination of seeds is common in many plant species. It is frequently caused by a tough or impervious seed coat and sometimes by an immature embryo which must complete its development after the seed is ripe. If none of these causes operates, delay is attributed to an internal condition which must be modified by a process called "after-ripening" and the time of delay is called the "rest period."

Seeds of Spanish peanuts planted soon after maturity in a greenhouse usually germinated immediately but a small proportion required short rest periods. Average rest periods of runner peanuts were 150 to 200 days with very few seeds germinating immediately. Studies of the inheritance of rest period in crosses between pure strains of the two groups were interpreted as indicating typical multigenic inheritance of a quantitative character, except that the character is expressed over only about one-half of the range of genetic variation. It was supposed that a basic seed condition on which rest period must depend may be a typical quantitative character with near-normal frequency distributions and that near the mid-point of genetic variation of seed condition is a threshold of germination. On one side of the threshold requirements for germination are met or exceeded and no rest period appears. On the other side a range of deficiency is expressed in rest periods of different lengths. A typical picture of quantitative inheritance with near-normal frequency distributions in pure strains and various hybrid

generations and families is, thus, transformed by having approximately the left one-half compressed into a single class of zero rest period. The right one-half appears without distortion.

Specific features of rest period behavior and their significance in supporting the interpretation were listed as follows:

1. Non-genetic variance of rest period was large in pure runner strains and in other samples with long rest requirements. It was greatly reduced in pure Spanish strains and other samples with short rest requirements. A pure strain with genotype potential for rest period exactly zero should show some rest period in approximately one-half of its seeds because of non-genetic variation. Pure strains of Spanish which showed rest period in fewer than 50 percent and as few as 10 percent of their seeds are indicated as having genotype potentials for less than zero rest period. They may have less than the number of genes necessary to produce rest period in any degree.

2. Every F_1 seed had a rest period of considerable length with the mean nearer the runner type indicating dominance of long rest period.

3. Nearly 50 percent of F_2 and later generation hybrid seeds germinated immediately or the phenotype of the lesser Spanish parent was fully recovered in them. Frequency distributions of remaining seeds in each sample appeared as the right one-half of a normal frequency distribution. This conforms with the theory that nearly 50 percent of genotypes have potential values less than zero for rest period. It cannot be attributed to dominance of germinability (2).

4. Mean rest periods of hybrid generations after F_1 were less than one-half of those of greater parents; or average breeding values of Spanish strains were negative. Breeding values of Spanish strains in crosses with a single runner strain differed significantly and in accordance with tests on seeds of the several pure Spanish strains. Transgressive segregation, far above the greater parent, appeared frequently in Spanish-runner crosses. It is indicated that Spanish strains have different genotypes with all of them of potential value less than zero and that certain genes whose general effect is to increase rest period may be found in the Spanish group but not in the runner group of peanuts. Any conclusion that immediate germination usually indicates a minimum genotype would be very difficult to establish.

GENETICS IN THE TAXONOMY OF *ARACHIS HYPOGAEA*, L.

FRED H. HULL
University of Florida

LOUREIRO (1790) assigned the bunch varieties of *A. hypogaea*, L. to one species *Asiatica* and the runner varieties to another *Africana*. De Candolle recombined them in 1823. Some early writers referred to the many seeded varieties like Valencia as the Peruvian type and to the remaining varieties with two seeds in a pod as the Brazilian type. Waldron (1919) assigned sub-specific rank to bunch and runner peanuts and postulated separate origins from different wild species. Hayes (1933) classified cultivated peanuts in two principal groups, bunch and runner. Chevalier (1933) makes five principal groups principally on the basis of seed size and pod thickness.

Three principal groups now proposed are runner, Spanish, and Valencia. Runner is distinguished by prostrate habit, russet seed coat, dark green foliage, long seeds, and long rest period of seeds. Spanish peanuts have erect habit, tan seed coat, light green

foliage, short seeds, short or no rest period, and rarely if ever more than two seeds in a pod. The Valencia group is the Peruvian type of early writers. It has three or more seeds in a pod usually but is more definitely determined by a very sparse branching habit and an atypical inflorescence with a rachis or central stem several inches in length. In the typical inflorescence the rachis is greatly reduced so the several flowers have sessile attachment.

This classification is further supported by the distribution of two sets of duplicate genes. One set controls the inheritance of yellow seedlings and the other that of sparse branching and atypical inflorescence which make up Valencia plant type. Genetic records assign the genotypes $l_1l_1 L_2L_2 Va_1Va_1 va_2va_2, L_1L_1 l_2l_2 va_1va_1 Va_1Va_1,$ and $L_1L_1 L_2L_2 va_1va_1 va_2va_2$ to the runner, Spanish, and Valencia groups of peanuts respectively. No exceptions have been noted.

All varieties of cultivated peanuts seem to intercross freely with no loss of fertility, although natural crosses are rare. All varieties have twenty pairs of chromosomes. Numerous pairs of duplicate genes suggest polyploidy, probably tetraploidy. The common peanut may have originated from a more primitive type by multiplication of chromosome number and ten chromosome types may exist at present among the wild species of South America.

NON-EFFECTIVE GENE FREQUENCIES

FRED H. HULL
University of Florida

INHERITANCE of rest period in peanut seeds was described at the previous meeting as multigenic with unique behavior interpreted to indicate zero expression of the character over approximately the lower one-half of the range of gene frequency. No parallel cases were known but one was discovered last summer in the inheritance of number of tillers per plant in maize.

Non-effective gene frequencies may have developed accidentally or in response to selection. Shifting to an environment favoring tillering would probably transform the mode of inheritance to the classical type. Conversely the reverse transformation could be made with tillers and other similar characters but the environmental responses of rest period in peanuts hardly admits this interpretation. If non-effective gene frequencies were produced by shift of environment and the new environment continued, selection for the character would eventually eliminate them.

Selection against the character especially with large non-genetic variance as found in both rest period and tillering would probably build up a range of non-effective gene frequencies. Such selection with some shift of environment seems the more plausible explanation in the case of tillering.

Non-effective gene frequencies may have developed in rest period where growing conditions prevailed generally except for rare adverse periods. (The peanut originated in the tropics.) Immediate germination of most seeds with varying rest periods in a few would be advantageous. Non-effective lower gene frequencies provide the mechanism to produce this highly skewed distribution. If zero rest period were a minimum genotype its occurrence would necessarily be rare. Large non-genetic variance adapts the mechanism to intense inbreeding which occurs at present. Long rest period types may be later developments in response to increasing regularity of growing conditions either from climatic changes or from migration to higher latitudes.

SOME FLORIDA CRAWFISHES AND THEIR HABITAT DISTRIBUTION

H. H. HOBBS, JR.
University of Florida

THE PROBLEM undertaken in the present study, has been to determine and distinguish the several local species of *Cambarus*; to ascertain their habitat distribution among the various ecological situations of the Gainesville Region.

Each of the six crawfish representatives in this region is associated with a more or less definite type of habitat. In spite of the overlappings which occur, and the situations in which more than one species are found, each of these crawfishes may be thought of in connection with a specific type or specific types of habitats.

1. *Cambarus advena geodytes* is a habitual burrower.
2. *Cambarus pubescens* is a flatwoods variety living in any of the temporary water systems of the flatwoods.
3. *Cambarus fallax* is peculiar to the ponds and lakes but is often found in habitats occupied by members of other species.
4. *Cambarus clarkipaeensulanus* inhabits the small springs and sandy bottom creeks where it often burrows into the clay or mud banks.
5. *Cambarus spiculifer* may be always associated with the large, clear, calcareous streams.
6. *Cambarus acherontis* is confined to the under-ground water systems where it is not associated with any of the other species.

TWO LARVAL CRANE-FLY MEMBERS OF THE NEUSTON FAUNA

J. SPEED ROGERS
University of Florida

THE NEUSTON comprises all the numerous and very diverse organisms that are associated with and dependent upon the surface film of fresh-water habitats. In contrast to the plankton (the submerged drifting organisms of the open waters), the nekton (the active submerged fauna) and the benthos (the bottom-living biota of both shallow and deep water), the neuston has been comparatively little studied but, in the quiet waters of sluggish streams, of ponds, and of marsh pools it forms a considerable part of the total aquatic biota.

Recently it has been found that the larvae of two species of crane-flies, *Megistocera longipennis* (Macq.) and *Limonia (D) distans* (Osten Sacken) often form a considerable though inconspicuous element of the neuston population of Florida ponds and "prairies." This is of particular interest in that these are the first instances known of neuston forms among the crane-flies; the larvae of the closest relatives of each of these two species have very different larval habitats, and these two neuston forms are not at all closely related; and that *Megistocera longipennis* has long been regarded as an extremely rare form.

A brief account of the habits, life cycles and adaptations of these forms to the neuston region is given.

THE PAST AND PRESENT STATUS OF SOME RARE AND THREATENED FLORIDA BIRDS

ALDEN H. HADLEY
Gainesville

Florida has long occupied a unique place among the states of the Union on account of her exceedingly rich and varied flora and fauna.

By reason of this fact our state has for many years been a mecca for naturalists and collectors and also for sportsmen as well as unscrupulous killers.

This situation, combined with an ever-advancing civilization, has given rise to many abuses which have produced a disastrous effect upon certain conspicuous and unusually interesting forms of bird life.

It is the purpose of this paper to give a brief review of the past and present status of certain of these species.

First to be dealt with are three birds which for some time have been the chief concern of the National Association of Audubon Societies in its determined efforts to save these forms from complete extirpation.

These species, in the order of the critical situation confronting them, are:

1. The Great White Heron
2. The Roseate Spoonbill
3. The Eastern Glossy Ibis

Also to be touched upon are other species the fortunes of which should be carefully watched and guarded, such as the Limpkin Florida Crane, Everglade Kite, Florida Burrowing Owl and the Ivory-billed Woodpecker.

COMMENTS ON THE RECENT MAMMALS OF FLORIDA

E. V. KOMAREK
Thomasville, Ga.

THE MAMMALS of Florida are divided into 97 species and subspecies; nine of these are sea mammals, five are introduced mammals, and only three are extinct. The land mammals only will be considered in this paper. The present mammalian fauna exclusive of sea, extinct, or introduced mammals consist of forty genera as follows.

Marsupials (<i>Marsupiala</i>)	1 genus, 1 species
Insectivores (<i>Insectivora</i>) (Shrews & Moles)	4 genera, 9 species and subspecies
Bats (<i>Chiroptera</i>)	9 genera, and probably 12 species and subspecies
Carnivores (<i>Carnivora</i>)	11 genera, 16 species and subspecies
Rodents (<i>Rodentia</i>)	10 genera, 37 species and subspecies
Rabbits (<i>Lagomorpha</i>)	1 genus, 4 species and subspecies
Ungulates (<i>Artiodactyla</i>)	1 genus, 3 species and subspecies

The extinct three species are 1 rodent, 1 bovine, 1 Artiodactyl.

The mammalian life of Florida is very diversified and unique. It contains more of its original mammalian fauna than any eastern state. It has a larger number of endemic species and subspecies than any eastern state. And Florida also has a larger number of species and subspecies of mammals than any other eastern state. Of the 80 native species and subspecies of land mammals now present in the state 33 are endemic. Two

of the species extinct in Florida are also extinct in reality. The third extinct species is present in small colonies in other southern states and further knowledge may yet show it to exist in Florida.

COMMENTS ON PROBLEMS IN MAMMALS OF FLORIDA

E. V. KOMAREK
Thomasville, Ga.

MAMMALOGY in Florida literally stopped, just after it had scarcely begun, with the war between the states and the area was still a wilderness. Since that time only sporadic collecting trips have been made into the state, and these usually during winter, so much that the "tourist" towns are clearly marked on a distribution map of collecting sites within Florida. Due to the activities of the staff of the Cooperative Quail Study Association and the Chicago Academy of Sciences this problem is rapidly being overcome by intensive collecting and studies, particularly in western and northwestern Florida.

At present we do not have a published check list of the mammals of Florida though one is in preparation. We know very little about the distribution of mammals within the state. Thus on maps and in taxonomic literature such a common mammal as the spotted skunk is limited to the east coast when apparently it occurs throughout Florida, at least above the Everglades. Further work on mammals will show a decided revision in the taxonomy of certain species.

We know very little of the food habits of even our most common mammals. In connection with studies on game birds we have learned that not more than seventy-five stomachs have been scientifically examined in eastern United States of such common mammals as the opossum or skunk. Very few of these came from Florida and these few from the region near Tallahassee.

Apparently little is known about the external or internal parasites of our native mammals, not only in Florida but in eastern United States. Thus a high percentage of both external and internal parasites of mammals in the southeast prove to be new species. The study of internal parasites of native mammals is so recent that most of the material collected in the past few years in the southeast, including Florida, can only be identified to genera by the Bureau of Animal Industry. One rather common bat in eastern Tennessee yielded two apparently new species of external parasites.

Apparently little is known about the diseases of our native animals and their relationship to domestic stock and man. We have found tularemia and coccidiosis in some mammals. At the present time we are studying a disease that has been prevalent in skunks in northwest Florida that shows general symptoms of being rabies.

When it comes to the more recent fields in science such as ecology, we find a blank page, for such studies must cover years, not weeks or months, to yield dependable information. Neither is there a life history study of any Florida mammal that might be considered anywhere near complete.

These fields of knowledge outlined above must be worked for we must know these things to manage intelligently our wildlife natural resource in Florida. Many of these things should be known so as to live more intelligently with our native mammals. Life has been likened to a web in which each strand supports others and in this field of wildlife conservation and restoration we do not know the main strands, let alone those minor ones which may be just as, and even more, important.

EFFECTS OF X-RAYS ON CORN

A. A. BLESS
University of Florida

EXPERIMENTS reported at the first meeting of the Academy indicated that no definite conclusions could be drawn from results obtained by irradiating a small number of seeds with X-rays. A larger number of specimens has been obtained in a field planting. Four separate lots of corn seeds were subjected to four different X-ray exposures of two wave lengths and two doses for each wave length. These seeds together with controls were planted in the field and so staggered as to minimize the effects of soil variation. One hundred hills of each strain containing three seeds were planted.

The seeds were of the inbred strain, which were kindly supplied by Mr. John P. Camp of the Florida Experiment Station. As the inbred strain is extremely susceptible to diseases and attacks of insects the number of whole ears was very much smaller than expected; only about twenty-five ears of each variety having been obtained. The records indicate that corn subjected to a certain X-ray treatment shows a 10 percent increase of average ear weight over the controls. However, it is believed that the number of specimens is not sufficient to warrant complete confidence in this result.

HAS THE STUDY OF MATHEMATICS A PLACE IN MODERN SOCIALIZED EDUCATION?

BARBARA DAVIS
Stetson University

THIS IS a progress report of a study of objectives, materials and methods of mathematics in education for a democratic society.

The basic place of science in giving the frame to modern life and of the need of reflective thinking and scientific method in giving the individual the opportunity for the fullest possible life are recognized. The existence of wide ranges of individual differences and of the consequent need for a more thorough analysis of the nature of the student and his mental processes are also recognized. The relation between the needs of society and the nature of the individual to be educated is the criterion which must determine the place of any given material in a student's curriculum. Neither the weight of classicism, of tradition, nor the growing inability to understand elementary scientific thought of those entrusted with making up students' high school and college schedules should be used to determine such materials.

This study starts from the University of Chicago four year investigation of the nature of intelligence and endeavors to find the true relation between education for social needs and the nature of the student mind thus assumed. By this process of logic the place of mathematics is assured.

Out of this relation, the objectives of mathematics courses are derived. From the objectives are drawn a few suggestions as to materials for inclusion in a college first course in mathematics, designed not exclusively for engineering, scientific and pure mathematics students.

**PROVERBS IN BROWNING'S *THE RING AND THE BOOK*:
THE SCIENTIFIC METHOD APPLIED TO A
PROBLEM IN ENGLISH LITERATURE**

CORNELIA MARSHALL SMITH
Stetson University

IN THE sixteenth century, generally conceded to be the golden age of the proverb, the quintessence of all learning including the great scientific truths was thought to be expressed in proverbs and aphorisms. In the seventeenth century, however, they fell into disfavor, and by the eighteenth century they were taboo in polite society. This aversion for proverbs continued into the nineteenth century. Scholars, therefore, have apparently taken for granted that Browning like most of his contemporaries, following the trend of the scientific era, abstained from using them. Apperson in his *English Proverbs and Proverbial Phrases*¹ attributes to Browning a single proverb and Smith in his *English Proverbs*² credits him with only five, none of which are cited from *The Ring and the Book*. It is the purpose of this brief communication to show how, by the application of the scientific method, it was found:

(1) That *The Ring and the Book* contains numerous proverbs, eighty-seven having been definitely identified.

(2) That the accumulation and classification of these proverbs discloses that Browning has followed the manner of ancient Latin grammarians in his use of them.

(3) That apropos to the setting of the poem:

A Roman murder-case:

.

At Rome on February Twenty Two,
Since our salvation Sixteen Ninety Eight:³

Browning with his keen historic imagination uses proverbs. Cognizant, however, of the fact that in the seventeenth century they were falling into disfavor, particularly with the more erudite and aristocratic, the poet says:

A proverb and a by-word men will mouth
At the cross-way, in the corner, up and down
Rome and Arezzo.⁴

Another poignant statement of the poet in this connection is:

Guido, thus made a laughing-stock abroad,
A proverb for the market-place at home,
Left alone with Pompilia now, this graft
So reputable on his ancient stock,
This plague-seed set to fester his sound flesh.⁵

Furthermore, examination reveals that of the proverbs used in *The Ring and the Book* the greatest number occur in those books which pertain to the common folk and their lawyers.

(4) That many of Browning's expressions have the structural turn of proverbs, a fact determined by comparing Browning's phrase patterns with the phrase patterns peculiar to proverbs.

¹ Apperson, G. L., *English Proverbs and Proverbial Phrases* (New York, 1929), p. 537.

² Smith, George William, *The Oxford Dictionary of English Proverbs* (Oxford, 1935), pp. 309, 321, 374, 527, 554.

³ *Complete Poetical Works of Robert Browning*, ed. by Augustine Birrell (New York, 1935), p. 651, ll. 28-35. ⁴ *Ibid.*, p. 736, ll. 69-71. ⁵ *Ibid.*, p. 674, ll. 33-37.

OFFICERS FOR 1936

President—Herman Kurz, Florida State College for Women, Tallahassee.

Vice-president—R. C. Williamson, University of Florida, Gainesville.

Secretary—J. H. Kusner, University of Florida, Gainesville.

Treasurer—J. F. W. Pearson, University of Miami, Coral Gables.

Chairman of the Biological Sciences Section—H. H. Hume, University of Florida, Gainesville.

Chairman of the Physical Sciences Section—Herman Gunter, State Geologist, Tallahassee.

Editor—T. H. Hubbell, University of Florida, Gainesville.

OFFICERS FOR 1937

President—H. Harold Hume, University of Florida, Gainesville.

Vice-president—Jennie Tilt, Florida State College for Women, Tallahassee.

Secretary—J. H. Kusner, University of Florida, Gainesville.

Treasurer—J. F. W. Pearson, University of Miami, Coral Gables.

Chairman of the Biological Sciences Section—Edward P. St. John, Floral City.

Chairman of the Physical Sciences Section—J. E. Spurr, Rollins College, Winter Park.

Editor—T. H. Hubbell, University of Florida, Gainesville.

LIST OF MEMBERS

FLORIDA

Altamonte Springs

*Beardslee, H. C. (Mycology)

Bradenton

Norfleet, Sara Camp (Chemistry)

Chattahoochee

Worchel, Philip, Florida State Hospital (Psychology)

Coconut Grove

*Zion, Jacob J., 2906 Oak Ave. (Chemistry and Biology)

Coral Gables

*Pearson, Hazel M., 223 Ave. Calabria (Ecology)

Sieplien, O. J., P.O. Box 215 (Chemistry)

University of Miami

*Buswell, W. M. (Botany)

*Clouse, J. H. (Physics)

*Fairchild, David (Botany)

*Gifford, J. C. (Forestry)

*Harrison, R. W.

* Charter member.

Lindstrom, Evan T. (Chemistry)

*Longenecker, W. B. (Mathematics)

*Meyer, Max F. (Psychology)

*Miller, E. Morton (Zoology)

*Pearson, J. F. W. (Zoology)

*Phillips, Walter S. (Botany)

**West, Henry S. (Psychology)

Davenport

*Floyd, B. F. (Horticulture)

Daytona Beach

Beach, Richard H., Mainland High School (Biology)

*Longstreet, Rupert J., 610 Braddock Ave. (Psychology and Ornithology)

DeLand

Stetson University

*Allen, R. I. (Physics)

*Campbell, Nelle (Zoology)

*Conn, John F. (Chemistry)

**Davis, Barbara J. (Mathematics and Physics)

*Faulkner, Donald (Mathematics)

*Hodges, Q. E. (Physics)

Kindred, John J. (Medicine) [Deceased]

**Linson, Elizabeth S. (Chemistry and Mathematics)

*Smith, Cornelia M. (Biology)

*Vance, Charles B. (Geology)

Englewood

*Bass, J. F., Jr., Bass Biological Lab. (Marine Biology)

*Springer, Stuart, Bass Biological Lab. (Zoology)

Eustis

*Kinser, B. M. (General)

Floral City

*St. John, Edward P. (Botany)

*St. John, Robert P. (Botany)

Frostproof

*Keenan, Edward T. (Soil Chemistry)

Gainesville

*Bruce, Malcolm, Fla. Mapping Project, Photo. Lab., U. of F. (General)

**Carr, Marjorie Harris, 440 Colson St. (Biology)

*Carr, T. D., 1828 W. Church St. (Physics)

*Foster, Harriet, 410 W. University Ave. (Biology)

*Freeman, Kenneth A., Box 2416 (Chemistry)

* Charter member.

** Associate member.

- *Guerra, Jorge, 243 De Soto St. (Chemistry)
- *Hadley, A. H., 146 Fla. Ct. (Ornithology)
- *Kallman, I. E., P.O. Box 2747 (General)
- *Martin, J. M., 1828 W. Church St. (Histology)
- *Rolf, C., 1422 W. Arlington St. (Botany)
- *Rolf, P. H., 1422 W. Arlington St. (Botany)

University of Florida

- *Abbott, O. D. (Home Economics)
- *Arnold, Lillian E. (Botany)
- *Atwood, R. S. (Geography)
- *Barnette, R. M. (Chemistry)
- *Becker, R. B. (Dairy Husbandry)
- *Bell, C. E. (Chemistry and Soils)
- *Berger, E. W. (Entomology)
- *Blackmon, G. H. (Horticulture)
- *Bless, A. A. (Physics)
- *Bryan, O. C. (Agronomy)
- *Byers, C. F. (Biology)
- *Camp, J. P. (Agronomy)
- *Carr, A. F., Jr. (Biology)
- *Carroll, W. R. (Bacteriology)
- *Carver, W. A. (Agronomy)
- *Chandler, H. W. (Mathematics)
- *Christensen, B. V. (Pharmacy)
- *Cody, M. D. (Botany)
- *Dauer, Manning J. (History and Political Science)
- *Davis, U. P. (Mathematics)
- *Dostal, B. F. (Mathematics)
- *Floyd, W. L. (Agriculture)
- *Foote, P. A. (Pharmacy)
- *French, R. B. (Chemistry)
- *Gaddum, L. W. (Biochemistry)
- *Gautier, T. N. (Physics)
- *Germond, H. H. (Mathematics)
- *Goin, Coleman (Biology)
- **Hampton, Burt L. (Chemistry)
- *Hawkins, J. E. (Chemistry)
- *Hawkins, S. O. (Pathology) [Deceased]
- *Hinckley, E. D. (Psychology)
- *Hobbs, H. H. (Biology)
- *Hubbell, T. H. (Biology)
- *Hull, F. H. (Genetics)
- *Hume, H. H. (Botany)
- *Ireland, E. J. (Pharmacy)

* Charter member.

** Associate member.

- *Johnson, R. S. (General)
- *Kilby, J. D. (Biology)
- *Kirk, W. G. (Animal Husbandry and Chemistry)
- *Knowles, H. L. (Physics)
- *Kusner, J. H. (Mathematics and Astronomy)
- *Leigh, T. R. (Chemistry)
- *Leukel, W. A. (Soil Chemistry)
- *Mehrhof, Norman R. (Poultry Husbandry)
- Merrill, G. B. (Entomology)
- Montgomery, J. H. (Entomology)
- *Mosier, Charles I. (Psychology)
- *Mowry, Harold (Horticulture)
- *Neal, W. M. (Animal Husbandry)
- Newell, Wilmon (Agriculture)
- *Newins, H. S. (Forestry)
- *Perry, W. S. (Physics)
- *Phipps, Cecil G. (Mathematics)
- *Pollard, C. B. (Chemistry)
- *Reitz, J. Wayne (Agricultural Economics)
- *Ritchey, George E. (Agronomy)
- *Rogers, J. Speed (Biology)
- *Rogers, L. H. (Chemistry)
- *Rusoff, L. L. (Biochemistry)
- *Senn, P. H. (Agronomy)
- *Shealy, A. L. (Animal Husbandry)
- *Sherman, H. B. (Biology)
- *Specht, Robert D. (Mathematics).
- *Stokes, W. E. (Agronomy)
- *Tigert, Jno. J. (Psychology)
- *Tisdale, W. B. (Plant Pathology)
- *Tissot, A. N. (Entomology)
- *Wallace, Howard K. (Biology)
- *Watson, J. R. (Entomology)
- *Weber, George F. (Plant Pathology)
- *Weil, Joseph (Engineering)
- *West, Erdman (Botany)
- *Williams, F. D. (Physics)
- *Williams, Osborne (Psychology)
- *Williamson, R. C. (Physics)
- *Willoughby, C. H. (Animal Husbandry)
- *Young, T. Roy, Jr. (Entomology)

Glenwood

- *Van Cleef, Alice (Chemistry and Biology)

Hastings

- Eddins, A. H., Agr. Exp. Sta. Laboratory (Plant Pathology)

* Charter member.

Hollywood

*Wray, Floyd L. (Horticulture)

Homestead

*Fifield, W. M., Sub-Tropical Exp. Sta. (Horticulture)

*Ruehle, George D., Exp. Station (Plant Pathology)

Jacksonville

*Buckland, Charlotte B., 2623 Herschel St. (Biology)

*Cason, T. Z., 2033 Riverside Ave. (Medicine)

**Clayton, A. L., Jr., 2253 Oak St. (Physics and Chemistry)

Diddell, W. D., 333 East Seventh St. (Botany)

*Dyrenforth, L. Y., 3885 St. Johns Ave. (Pathology)

*Farris, C. D., 454 E. Sixth St. (Chemistry)

*George, C. R., Jr., 1514 Barnett National Bank (Archeology)

*MacGowan, W. Leroy, 3212 Park St. (Biology)

*Mahorner, Sue A., 1755 Greenwood Ave. (Psychology)

*Parker, Horatio N., 2777 Park St. (Public Health)

*Thomas, R. H., 37 S. Hogan St. (Electricity)

Key West

*Giovannoli, Leonard, Key West Aquarium (Ichthyology)

*Pierce, E. Lowe (Biology)

Lake Alfred

*Camp, A. F., Citrus Exp. Sta. (Horticulture)

Lake City

*Heyward, Frank, South Florida Experiment Station (Forestry)

Lakeland

Florida Southern College

*Bly, R. S. (Chemistry)

*DeMelt, W. E. (Psychology)

*Reinsch, B. P. (Mathematics, Physics)

Sims, Harris (General)

Spivey, Ludd M. (Sociology, Psychology)

Lantana

**Smith, Maxwell (Biology)

Leesburg

*Goff, C. C., Leesburg Expt. Sta. Lab. (Plant Pathology)

*Goff, Dorothy S., 501 Line Street (Zoology)

*Loucks, K. W., Leesburg Expt. Sta. Lab. (Plant Pathology)

*Shippy, William B., Leesburg Expt. Sta. Lab. (Plant Pathology)

*Walker, Marion N., Leesburg Expt. Sta. Lab. (Plant Pathology)

Manatee

Tallant, W. M. (Archeology)

* Charter member.

** Associate member.

McIntosh

*Gist, N. N., Box 7 (Agriculture)

Melrose

*Norris, Louise (Zoology)

Miami

*Brown, S. H., c/o Pan American Airways (Meteorology)

*Faust, Burton, 436 N.E. 94 St. (Mathematics)

Kramer, Charles Wilson, 2328 S.W. 17th St. (Plant Physiology)

*Marshall, J. J., 918 Seybold Bldg. (Astronomy)

*Mosier, Charles A., 3902 N.W. Third Ave. (Biology) [Deceased]

Murray, Mary R., Robert E. Lee Jr. High School (General)

Mount Dora

*Sadler, G. G., 315 N. Highland St. (Zoology)

Orlando

*Bahrt, G. M., P.O. Box 629 (Chemistry, Agriculture)

*Fernald, H. T., 707 E. Concord St. (Entomology)

*Kime, C. D., Box 222 (Agriculture)

*Levy, Morton, 521 Revere St. (Biology)

*Lord, E. L., P.O. Box 1948 (Horticulture)

*Miller, Ralph L., Fla. Agr. Supply Co. (Agriculture)

*Robinson, Ralph T., P.O. Box 1058

*Stevens, H. E., 224 Annie St. (Horticulture)

*Stubbs, Sidney A., Route 2 (Geology)

Ormond

*Braren, Herbert, P.O. Box 136 (Biology)

Panasoffkee

*Tanner, W. Lee (Chemistry)

Pass-a-Grille Beach

*Fargo, W. G., P.O. Box 283 (Ornithology)

Plymouth

*Mathews, E. L. (Horticulture)

Quincy

*Kincaid, R. R., North Fla. Expt. Sta. (Plant Pathology)

St. Petersburg

*Smith, Frank, 2219 7th St. N. (Zoology)

*Story, Helen F., 2762 Burlington Ave. (Astronomy, Mathematics)

*West, Frances L., St. Petersburg Junior College (Biology)

Sanford

*Gut, H. James, P.O. Box 700 (Paleontology)

* Charter member.

Silver Springs

Allen, E. Ross (Herpetology)

South Jacksonville

*Armstrong, J. D., Rt. 1, Box 70 (Chemistry, Physics)

Tallahassee

- *Baker, Harry Lee, State Forester (Forestry)
- *Boyd, M. F., P.O. Box 793 (Epidemiology)
- *Coulter, C. H., 212 E. Georgia Ave. (Forestry)
- *Greene, E. Peck, P.O. Box 42, (Chemistry)
- *Gunter, Herman, State Board of Conservation (Geology)
- *Hart, Gordon, 612 W. Call St. (Chemistry)
- *Lynn, Edith, 503 W. Jefferson St. (Physics)
- *Owen, B. Jay, P.O. Box 346 (Chemistry)
- *Partridge, Sarah W., 508 S. Duval St. (Biology)
- *Pfluge, Margaret, 315 W. Park St. (Biology)
- *Ponton, G. M., Fla. State Road Dept. (Geology)
- *Raa, Ida, Leon High School (Chemistry)
- *Raudenbush, E. J., State Chemistry Laboratory (Chemistry)
- *Smith, Richard M., 537 Oakland Ave. (Chemistry)
- *Taylor, J. J., State Chemist (Chemistry)
- *Westendick, Frank, Fla. Geological Survey (Geology)

Florida State College for Women

- *Barber, Lanas S. (Biology)
- Barrows, W. M., Jr. (Physics)
- *Bellamy, R. F. (Sociology)
- *Boliek, M. Irene (Zoology)
- *Connor, Ruth (Home Economics)
- *Conradi, Edward (Psychology)
- *DeGraff, Mark H. (Education)
- *Deviney, Ezda (Zoology)
- *Disher, D. R. (Psychology)
- *Doyle, S. R. (Biology)
- Eyman, Ralph L. (Education)
- *Finner, Paul F. (Psychology)
- *Graham, Viola (Physiology)
- *Griffing, Elizabeth (Bacteriology)
- *Heinlein, C. P. (Psychology)
- *Heinlein, J. H. (Psychology)
- *Kurz, Herman (Botany)
- *Larson, Olga (Mathematics)
- *Lewis, Leland J. (Chemistry)
- *McKinnel, Isabel (Chemistry)
- *Moore, Coyle E. (Sociology)
- *Moore, F. Clifton (Medicine)

* Charter member.

- *Parsons, Rhey Boyd (Education)
- *Richards, Harold F. (Physics)
- *Salley, Nathaniel M. (General)
- *Sandels, Margaret R. (Home Economics)
- *Schornherst, Ruth (Botany)
- *Stewart, Alban (Botany and Bacteriology)
- *Tilt, Jennie (Chemistry)
- *Tracy, Anna M. (Nutrition)
- *Vermillion, Gertrude (Chemistry)
- *Waskom, Hugh L. (Psychology)
- *White, Sarah P. (Medicine)

Tampa

- *Becknell, G. C., University of Tampa (Physics, Mathematics)
- *Simpson, J. Clarence, 114 S. Plant Ave. (Archeology)

Umatilla

- *Williams, Henry W., Drawer C (Herpetology)

Venice

- *Albee, Fred H. (Medicine)

Wakulla

- *Bacon, Milton E., Jr. (Archeology, Geology)

Weirsdale

- *Erck, G. H. (Agriculture)

West Palm Beach

- *Young, John W., 720 Glen Ridge Drive (Mathematics, Physics)

Winter Garden

Schofield, H. L., Jr., Lakeview High School (Chemistry, Biology)

Winter Park

- *Barbour, R. B., 656 Interlachen Ave. (Chemistry)
- *Scott, George G., Grand Avenue (Biology)

Rollins College

- *Anderson, W. S. (Chemistry)
- *Davis, E. M. (Ornithology, Entomology)
- *Osborn, Herbert (Zoology, Entomology)
- *Schor, Bernice C. (Biology)
- *Spurr, J. E. (Geology)
- *Stiles, C. Wardell (Zoology)
- *Waddington, Guy (Chemistry)
- *Weinberg, Edward F. (Mathematics)
- *Wise, Louis E. (Chemistry)

* Charter member.

OUT OF STATE

Ann Arbor, Mich.

Blair, W. F., Lab. of Vertebrate Genetics, Univ. of Mich. (Biology)

Baltimore, Md.

*Kelly, Howard A., 1406 Eutaw Place (Medicine)

Buffalo, N.Y.

**Babcock, L. L., 726 Delaware Ave. (Ichthyology)

Columbia, S.C.

*Singleton, Gray, Federal Land Bank (Horticulture)

Ithaca, N.Y.

*Swanson, D. C., Department of Physics, Cornell University (Physics)

Raleigh, N.C.

*Van Leer, B. R., N. C. State College (Engineering)

Washington, D.C.

*Browne, C. A., Bureau of Chemistry and Soils, U.S.D.A. (Chemistry)

*McClanahan, R. C., U. S. Biological Survey (Biology)

* Charter member.

** Associate member.

CHARTER OF THE FLORIDA ACADEMY OF SCIENCES

ARTICLE I. NAME. The name of this corporation shall be Florida Academy of Sciences.

ARTICLE II. PURPOSES. The purposes of the Academy shall be to promote scientific research, to stimulate interest in the sciences, to further the diffusion of scientific knowledge, to unify the scientific interests of the state and to issue an annual scientific publication.

ARTICLE III. MEMBERSHIP. Election to membership in the Academy shall be by vote of the Council, upon written nomination by two members.

ARTICLE IV. TERM OF CHARTER. This corporation shall have perpetual existence.

ARTICLE V. OFFICERS. The affairs of the Academy shall be managed by the following officers, to-wit: President, Vice-president, Secretary and Treasurer.

ARTICLE VI. COUNCIL. The officers, together with the immediate past President, and such additional members as are provided in the By-Laws, shall constitute the Council of the Academy.

ARTICLE VII. INITIAL OFFICERS. The names of the officers who shall manage all the affairs of the Academy until the first election under this Charter are as follows:

President—Herman Kurz

Vice-president—R. C. Williamson

Secretary—J. H. Kusner

Treasurer—J. F. W. Pearson

ARTICLE VIII. BY-LAWS. The By-Laws of the Academy shall be made, altered, amended or rescinded at any annual meeting by a two-thirds vote of the members present.

ARTICLE IX. INDEBTEDNESS. The highest amount of indebtedness or liability to which the Academy may at any time subject itself shall never be greater than two-thirds of the value of the property of the Academy.

ARTICLE X. REAL ESTATE. The amount in value of the real estate which the Academy may hold, subject always to the approval of the Circuit Judge, shall be \$100,000.00.

BY-LAWS

DIVISION I. MEMBERSHIP

1. The annual dues shall be two dollars for members, one dollar for associate members, payable in advance.
2. Members or associate members whose dues become one year in arrears shall be automatically dropped from membership, after due notice has been given by the Secretary.
3. All persons who become members of the Academy during the year 1936 shall be designated as Charter Members of the Academy.

DIVISION II. SECTIONS

1. There shall be such sections of the Academy as the Council may authorize.
2. All section meetings shall be open to all members, but members shall vote concerning section matters only in those sections in which they are enrolled, and no member shall be enrolled in more than two sections, except by permission of the Council.
3. There shall be a Chairman of each section.
4. The Chairman of each section shall be, ex-officio, a member of the Council.

DIVISION III. OFFICERS

1. The President shall discharge the usual duties of a presiding officer at all meetings of the Academy and of the Council, and shall give an address to the Academy at the final meeting of the year for which he is elected.
2. The Vice-president shall assume the duties of the President in the latter's absence.
3. The Secretary shall keep the records of the Academy and of the Council. He shall have charge of the sale and exchange of the PROCEEDINGS.
4. The Treasurer shall have charge of the finances of the Academy.
5. The Council shall exercise general supervision over all the affairs of the Academy in the intervals between meetings of the Academy. Specific duties of the Council shall be:
 - a) To be responsible for the publications of the Academy.
 - b) To elect members and associate members.
 - c) To fill vacancies in any of the offices of the Academy.
 - d) To invest the funds of the Academy.
 - e) To make recommendations to the Academy in matters pertaining to general policy.
 - f) To nominate a candidate for each office.
 - g) To appoint an Auditing Committee.
 - h) To appoint an Editor.
 - i) To determine affiliation relations of the Academy.
 - j) To choose the time and place of meetings of the Academy.
 - k) To prepare programs for the meetings of the Academy.
 - l) To authorize the formation of Sections of the Academy.

DIVISION IV. ELECTIONS

1. The officers and section chairmen of the Academy shall be elected at the last session of the annual meeting.
2. The Council shall nominate a candidate for each office, but additional nominations may be made by any member.
3. Officers shall be elected by vote of the members present at the annual meeting.
4. Section chairmen shall be elected by vote of the members enrolled in their respective sections and present at the annual meeting.
5. A plurality of the votes cast for each office shall constitute election.
6. The officers thus elected shall enter upon their duties at the adjournment of the annual meeting.
7. Vacancies which occur in any office or committee chairmanship between annual meetings shall be filled by the Council.

DIVISION V. PUBLICATIONS

1. There shall be published an annual volume to be called the PROCEEDINGS OF THE FLORIDA ACADEMY OF SCIENCES.
2. The PROCEEDINGS shall be under the immediate control of the Council, through an Editor to be chosen by the Council annually. Upon being chosen, the Editor shall become a member of the Council.
3. One copy of the PROCEEDINGS shall be supplied free to each paid up member and associate member.

DIVISION VI. FINANCIAL MATTERS

1. The fiscal year of the Academy shall be the calendar year, and the accounts of the Treasurer shall be balanced January 1 of each year.
2. Prior to each annual meeting the Council shall select an auditing committee of two members which shall inspect the financial records of the Academy and report on them to the annual meeting.
3. All orders which involve payment of the funds of the Academy shall be signed by the President and the Secretary.

DIVISION VII. AFFILIATIONS

1. Affiliation relations between the Academy and other organizations may be arranged by the Council on such terms as it may decide in each case, subject to the approval of the annual meeting.

DIVISION VIII. MEETINGS

1. There shall be at least one meeting of the Academy annually.
2. The time and place of meetings shall be determined by the Council.
3. Meetings shall be conducted under Roberts' Rules of Order.
4. At least thirty days written notice of each annual meeting shall be given.
5. The Council shall be the program committee for the general sessions at any meeting. The Secretary together with the Chairman of each section shall constitute the program committee for that section.
6. At any meeting of the Academy of which thirty days notice has been given, those present shall constitute a quorum; at other meetings, one-fourth of the members.

DIVISION IX. AMENDMENTS (as provided in Charter)

1. By-Laws may be made, altered, amended or rescinded at any annual meeting by a two-thirds vote of the members present.



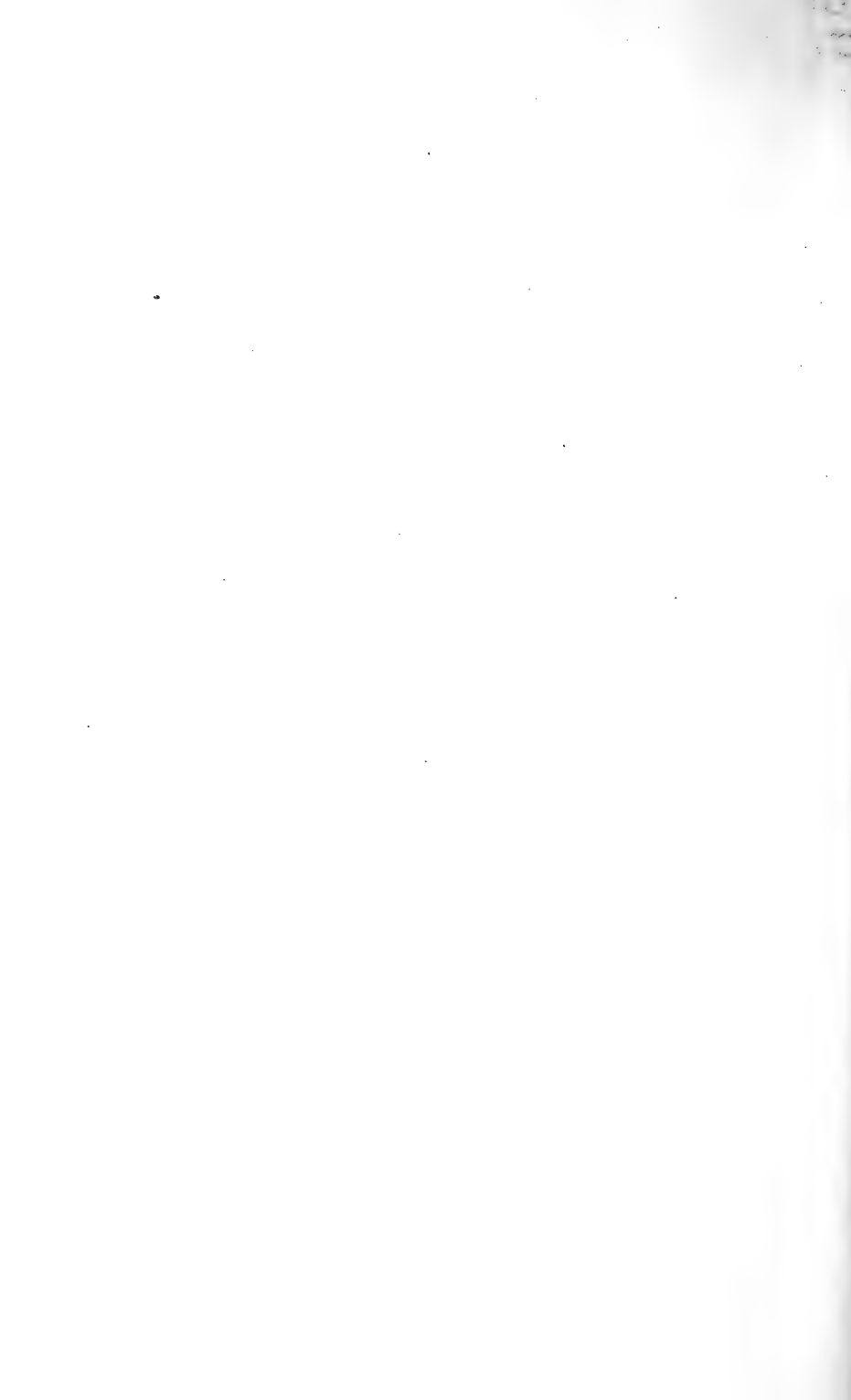

06.73
-6F63

PROCEEDINGS
of the
Florida Academy
of
Sciences
for
1937

VOL. II

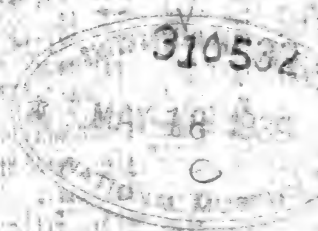

Published by the Academy
1938

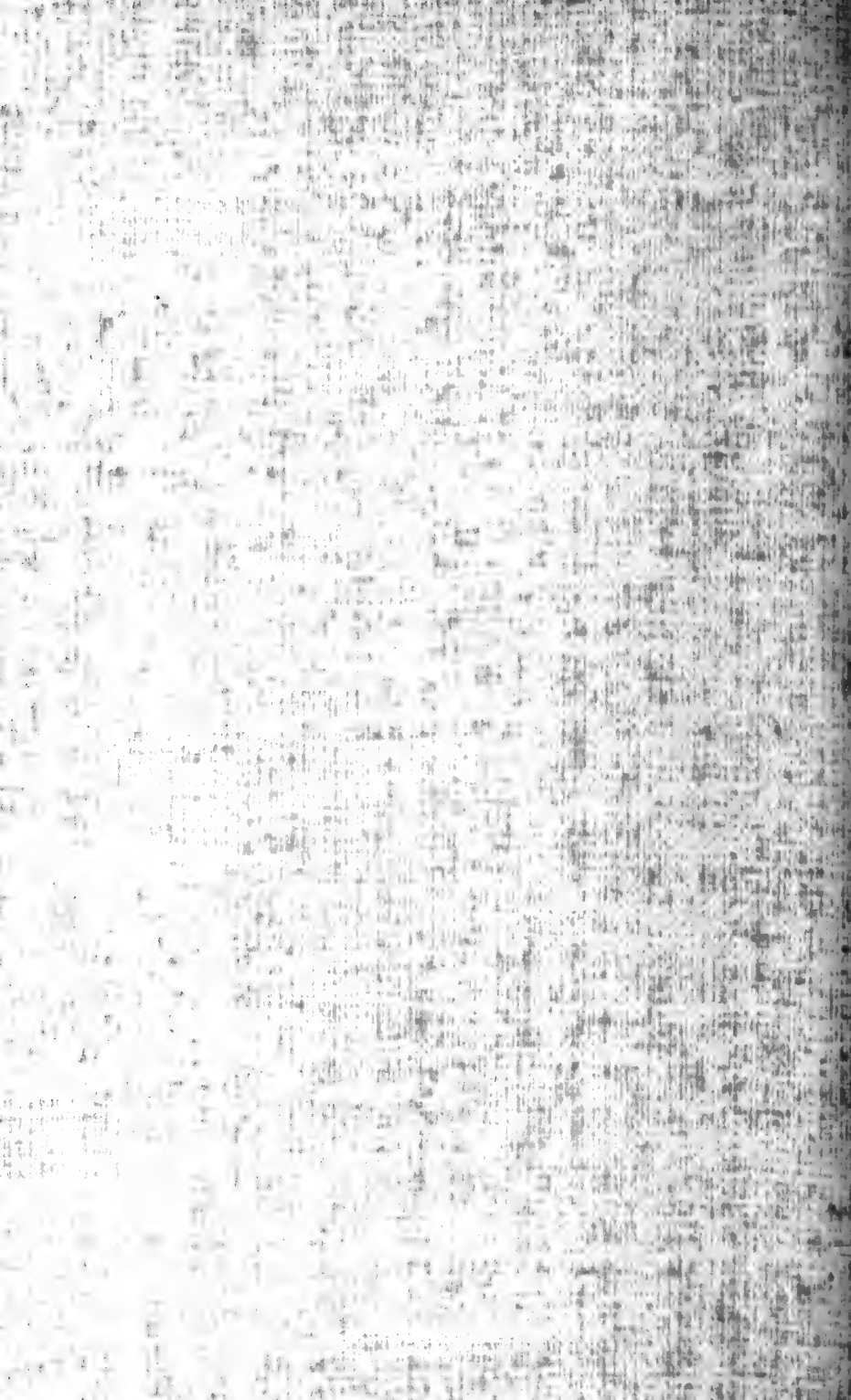

PROCEEDINGS
of the
Florida Academy
of
Sciences
for
1937

VOL. II

Published by the Academy
1938

THE PROCEEDINGS OF THE FLORIDA ACADEMY OF SCIENCES are issued annually under the direction of the Council of the Academy acting through the Editor and the Business Manager.

For this volume these officers are:

Editor H. HAROLD HUME

Business Manager R. S. JOHNSON

THE PROCEEDINGS are sent to all members of the Academy and are available for sale and for exchange. The price of this volume is \$1.00, bound in paper, and \$2.00, bound in cloth. Orders and correspondence concerning exchange should be sent to the Secretary, J. H. Kusner, University of Florida, Gainesville, Florida.

CONTENTS

The Academy During 1937.—J. H. KUSNER, <i>Secretary</i>	1
Treasurer's Report.—J. F. W. PEARSON, <i>Treasurer</i>	2
Program of the Second Annual Meeting, at Coral Gables.....	3

PAPERS

Advancing Knowledge of Florida's Vast Plant Life. Address of H. HAROLD HUME, <i>Retiring President</i>	5
Limitations of the Probable Error of Estimate in Predicting The Course of Human Behavior.—CHRISTIAN P. HEINLEIN.....	12
An Example of the Quantitative Method in Social Psychology.—CHARLES I. MOSIER	17
A Study of the Artesian Water Supply of Seminole County, Florida.—SIDNEY A. STUBBS.....	24
The Effect of Cold Storage on Certain Native American Perennial Herbs. Part I.—HERMAN KURZ.....	36
Check List of Native and Naturalized Trees in Florida.—LILLIAN E. ARNOLD	52
Taxonomic Characters and Habitats of Some of the Most Common Florida Mycetozoa.—CHARLOTTE B. BUCKLAND	67
Florida Snake Venom Experiments.—E. ROSS ALLEN.....	70
Allergic Hypersensitivity and the Four Blood Groups.—LUCIEN Y. DYRENFORTH	76
An Amplifier for Small Thermal Currents.—DUDLEY WILLIAMS and RICHARD TASCHEK	79
ABSTRACTS: The Infrared Absorption of Vitamins C and D, by LEWIS H. ROGERS; Traits in the Neurotic Inventory, by CHARLES I. MOSIER; Philosophical Integrity in Science Teaching, by HAROLD RICHARDS; The Division of Labor in the Natural Sciences, by JOHN P. CAMP; <i>Torreya</i> West of the Appalachian River, by HERMAN KURZ; Banana Water-lilies, by ERDMAN WEST; The Flora of Fort George Island, by Mrs. W. D. DIDDELL; Scientific Theory and Possible Practice of the Bichromatic Scale, by MAX F. MEYER; Chemical Analysis of Some North Carolina Scallops, by CHARLES E. BELL; Our Calendar and Its Reform, by CECIL G. PHIPPS; Raman Spectra of Water Solutions of Methanol, Ethanol, Acetone, Acetic Acid, and Dioxane, by R. C. WILLIAMSON; An Experiment to Determine the Effect of Severe Atmospheric Disturbances on the Ozone Content of the Upper Atmosphere, by W. S. PERRY and R. G. LARRICK; Physiological and Evolutionary Theories of Non-Additive Gene Interactions, by FRED H. HULL; The Effects of Elastic Stretch on the Infrared Spectrum of Rubber, by RICHARD TASCHEK; A New Automatic Respiration Calorimeter, by W. M. BARROWS, JR.; A Suggested New Notation for Logarithms, by H. H. GERMOND; Two New Crawfishes from Florida, by H. H. HOBBS; The Genus <i>Haylockia</i> , by H. H. HUME	83

iv PROCEEDINGS OF THE FLORIDA ACADEMY OF SCIENCES

Charter	91
By-Laws	92
List of Members, 1937	94

THE ACADEMY DURING 1937

IN JANUARY, 1937, the American Association for the Advancement of Science allotted to the Academy \$50.00 for use as a grant to be open to members of the Academy as an aid in research. Notice of this was sent to all members of the Academy, and applications for the grant were invited. The Council subsequently awarded the grant to Dr. F. Dudley Williams, of the Department of Physics, University of Florida, for the construction of an amplifier to be used in connection with certain investigations of the infra-red absorption spectrum of simple sugars and the effects of certain ions on liquid water.*

The second annual meeting of the Academy was held at the University of Miami on November 18, 19, and 20. The complete program of this meeting appears in the following pages. Committees for this meeting were:

LOCAL COMMITTEE ON ARRANGEMENTS: Walter S. Phillips, E. Morton Miller, E. T. Lindstrom, and J. H. Clouse, all of the University of Miami.

NOMINATING COMMITTEE:

Preliminary: W. E. DeMelt (Florida Southern College), Chairman, J. Gifford (University of Miami), Vice-Chairman, J. F. Conn (Stetson University), L. Y. Dyrenforth (St. Luke's Hospital, Jacksonville), B. J. Owen (Tallahassee), Bernice Shor (Rollins College), Frances L. West (St. Petersburg Junior College), Sarah P. White (Florida State College for Women), R. C. Williamson (University of Florida).

Final: R. C. Williamson (University of Florida), Chairman, E. M. Miller (University of Miami), B. P. Reinsch (Florida Southern College), Jennie Tilt (Florida State College for Women), Cornelia Smith (Stetson University).

RESOLUTIONS COMMITTEE: R. I. Allen (Stetson University), Chairman, W. M. Barrows, Jr. (Florida State College for Women), R. S. Bly (Florida Southern College), W. L. MacGowan (Robert E. Lee High School, Jacksonville), W. S. Perry (University of Florida).

*See page 79 of this volume.

MEDAL COMMITTEE: W. S. Phillips (University of Miami), Chairman, B. P. Reinsch (Florida Southern College), Cornelia Smith (Stetson University), Jennie Tilt (Florida State College for Women).

MEMORIALS COMMITTEE: Herman Gunter (Tallahassee), Chairman, R. I. Allen (Stetson University), G. F. Weber (University of Florida).

AUDITING COMMITTEE: G. D. Ruehle (University of Florida), Chairman, W. M. Buswell (University of Miami).

PUBLICITY COMMITTEE: L. W. Gaddum (University of Florida), Chairman, H. F. Richards (Florida State College for Women), Henry S. West (University of Miami).

At the business session of the Annual Meeting certain amendments to the By-laws* were voted.

On the recommendation of the Medal Committee, the Council subsequently voted to award the Achievement Medal for 1937 to Mr. Sidney A. Stubbs for his paper *A Study Of The Artesian Water Supply Of Seminole County, Florida.*†

The Council also voted to hold the 1938 Annual Meeting at Rollins College, Winter Park, on November 18 and 19.

J. H. KUSNER, *Secretary.*

TREASURER'S REPORT

FISCAL YEAR—1937-1938

CASH POSITION AS OF NOVEMBER 18, 1937

	Debit	Credit	Balance
Total receipts fiscal year 1935-36.....	\$	\$356.00	\$
Total disbursements fiscal year 1935-36.....	53.00		
Balance on hand fiscal year 1935-36.....			303.00
Total receipts fiscal year 1936-37.....		517.05	
Total disbursements fiscal year 1936-37.....	85.66		
Cash balance for fiscal year 1936-37.....			431.39
Balance from 1935-36.....			303.00
			<hr/>
Total cash on hand November 18, 1937.....			\$734.39

FINANCIAL OPERATION SINCE FOUNDING OF ACADEMY

	Paid Out	Paid In	Balance
Paid out on order of Pres. and Sec., 1935-36....	\$ 51.00	\$	\$
Refund of dues paid in error.....	2.00		
Received profit on inaugural meeting.....		1.00	
Received 1936 dues, 234 members.....		468.00	
Received 1936 dues, 13 associate members.....		13.00	
Received 1936 dues, 1 member, in error.....		2.00	
Balance actual 1935-36 funds available.....			431.00

*See page 92 of this volume.

†See page 24 of this volume.

	Paid Out	Paid-In	Balance
Paid out on order of Pres. and Sec., 1936-37....	83.66		
Refund of dues paid in error.....	2.00		
Received 1937 dues, 176 members.....		352.00	
Received 1937 dues, 9 associate members.....		9.00	
Received 1937 dues, 1 member, in error.....		2.00	
Balance actual 1936-37 funds available.....			277.34
Received 1938 dues, 12 members.....		24.00	
Received 1938 dues, 1 member.....		2.05	
Balance actual 1938-39 funds available.....			26.05
Total cash on hand, November 18, 1937.....			\$734.39

—J. F. W. PEARSON, *Treasurer*

PROGRAM OF THE SECOND ANNUAL MEETING

THURSDAY, NOVEMBER 18, 1937

BOTANICAL AND ZOOLOGICAL FIELD TRIPS

Under the Auspices of the Departments of Botany and Zoology, University of Miami.

- 9:00 A. M. Leave the University for an all-day Marine Zoological Trip under the direction of J. F. W. Pearson, Professor of Zoology, and E. M. Miller, Assistant Professor of Zoology, University of Miami. The boat will go down Biscayne Bay and outside to Fowey Light, below Soldier Key if possible. Diving will be in from 15 to 30 feet of water. Each person making the trip will be given the opportunity to dive and view the underwater life.
- 9:30 A. M. Leave the University for an all-day Botanical Trip to Costello Hammock under the direction of W. S. Phillips, Professor of Botany, and W. M. Buswell, Curator of the Herbarium, University of Miami. The trip will be to Costello Hammock, one of the many hammocks typical of the region between Miami and Homestead. This hammock has several large sink holes where tropical ferns are found. On the trip down, mangrove swamps and salt marshes will be seen. The return will be through the Miami Pinelands to the Everglades, and some interesting transitions between these two societies will be observed.

FRIDAY, NOVEMBER 19, 1937

GENERAL SESSION

PRESENTATION OF PAPERS: President H. Harold Hume presiding.

1. The Division of Labor in the Natural Sciences—John P. Camp, University of Florida.
2. Florida Snake Venom Experiments—E. Ross Allen, Florida Reptile Institute.
3. An Example of the Quantitative Method in Social Psychology—Charles I. Mosier, University of Florida.
4. Philosophical Integrity in Science Teaching—Harold Richards, Florida State College for Women.

4 PROCEEDINGS OF THE FLORIDA ACADEMY OF SCIENCES

5. Limitation of the Probable Error of Estimate in Predicting the Course of Human Behavior—C. P. Heinlein, Florida State College for Women.
6. *Torreya* West of the Apalachicola River—Herman Kurz, Florida State College for Women.

BIOLOGICAL SCIENCES SECTION

PRESENTATION OF PAPERS: Chairman E. P. St. John presiding.

1. The Flora of Fort George Island—Mrs. W. D. Diddell, Jacksonville.
2. The Effect of Cold Storage on Certain Native American Perennial Herbs (Part I)—Herman Kurz, Florida State College for Women.
3. Taxonomic Characters and Habitats of Some of the Most Common Florida Mycetozoa—Charlotte B. Buckland, Landon High School, Jacksonville.
4. Report on the Florida Copperhead (*Agkistrodon mokasen*)—E. Ross Allen, Florida Reptile Institute.
5. Physiological and Evolutionary Theories of Non-Additive Gene Interactions—Fred H. Hull, University of Florida.

PHYSICAL SCIENCES SECTION

PRESENTATION OF PAPERS: Chairman J. E. Spurr presiding.

1. A Study of the Artesian Water Supply of Seminole County, Florida—Sidney A. Stubbs, Sanford.
2. The Infra-red Absorption Spectrum of Vitamins C and D—Lewis H. Rogers, University of Florida.
3. The Effects of Elastic Stretch on the Infra-red Spectrum of Rubber—Richard Taschek, University of Florida.
4. A Suggested New Notation for Logarithms—H. H. Germond, University of Florida.
5. An Experiment to Determine the Effect of Severe Atmospheric Disturbances on the Ozone Content of the Upper Atmosphere—W. S. Perry and R. G. Larrick, University of Florida.

BANQUET

Toastmaster: Jennie Tilt, Vice-President of the Academy.

Address of Welcome: Bowman F. Ashe, President, University of Miami.

Retiring Address: H. Harold Hume, President of the Academy.

Presentation of the Achievement Medal for 1936: Herman Kurz, Past President of the Academy.

SATURDAY, NOVEMBER 20, 1937

BIOLOGICAL SCIENCES SECTION

PRESENTATION OF PAPERS: Chairman E. P. St. John presiding.

1. Chemical Analysis of Some North Carolina Scallops—Charles E. Bell, University of Florida.
2. Allergic Hypersensitivity and the Four Blood Groups—L. Y. Dyrenforth, St. Luke's and Riverside Hospitals, Jacksonville.
3. Banana Water Lilies—Erdman West, University of Florida.
4. Two New Crawfishes from Florida, *Cambarus hubbelli* and *Cambarus Acheronitis pallidus*—Horton H. Hobbs, Jr., University of Florida. By title.
5. Check List of Native and Naturalized Trees in Florida—Lillian E. Arnold, University of Florida. By title.

6. The Genus *Haylockia*—H. Harold Hume, University of Florida. By title.

BUSINESS MEETING OF THE BIOLOGICAL SCIENCES SECTION

PHYSICAL SCIENCES SECTION

PRESENTATION OF PAPERS: Chairman J. E. Spurr presiding.

1. A New Automatic Respiration Calorimeter—W. M. Barrows, Jr., Florida State College for Women.
2. Raman Spectra of Water Solutions of Methanol, Ethanol, Acetone, Acetic Acid, and Dioxane—R. C. Williamson, University of Florida.
3. An Amplifier for Small Thermal Currents—Dudley Williams, University of Florida.

BUSINESS MEETING OF THE PHYSICAL SCIENCES SECTION

GENERAL SESSION

(Two Parts Meeting Simultaneously)

PART A. Theory and Possible Practice of the Bichromatic (24-Tone, Quarter-tone) Scale; with Musical Demonstrations—Max F. Meyer, University of Miami.

PART B. Our Calendar and Its Reform—Cecil G. Phipps, University of Florida.

BUSINESS SESSION

ADVANCING KNOWLEDGE OF FLORIDA'S VAST PLANT LIFE*

H. HAROLD HUME

University of Florida

FLORIDA'S NATIVE Flora—one of the largest and most varied in the world, comprises more than 3,500 species of flowering plants alone to say nothing of lower forms. Of trees there are at least 314 species, a number greater than is found in any other state in the Union. Compare this number, for instance, with the trees of the Pacific Coast, where from Vancouver to Mexico only 147 species are indigenous. Approximately there are 352 species of grasses known as natives in this state. These numbers are not given for purposes of comparison alone but to indicate something of the wealth of plant material that covers the state of Florida.

The geographical position of the state, its climate, its topography, and its geological formation are responsible in large measure for the varied nature of its vegetation. Into its composition three main elements enter. One from northern regions represented by such plants as *Iris virginica*, *Saracenia purpurea*, *Ilex opaca*, and *Chamaecyparis thyoides*. Another peculiar to the state and found nowhere else than within its borders composed

*Retiring Presidential Address.

of such plants as *Rhododendron Chapmanii*, *Taxus floridana*, *Ilex cumulicola*, *Iris savannarum*, and *Zephyranthes Simpsonii*. And a third, essentially tropical, to which such plants as *Ficus aurea*, *Roystonea regia*, *Tillandsia juncea*, and *Swietenia Mahagoni* belong. Plants from these distinct sources in bountiful blending have found and maintained a place here. Is it any wonder that this was an inviting and interesting field for the botanist and collector? The lure of plant life, the beauty and variety of its forms have brought many plantmen to Florida as well as to neighboring states to the northward where vegetation has much in common with our own. Here came in earlier days many men from across the ocean—English, Scotch, Irish, French, and from our own northeastern states, botanists and collectors all, searching for new and unusual plants. Many of them made their headquarters in Charleston, for in those days it was the most southernly port and offered opportunity for the dispatch of plants and plant materials across the sea. As a result of their activities highly prized collections of plants, plant materials, and plant products found their way across the Atlantic to enrich and grace the gardens of Europe, to find a cherished place on the shelves of herbaria, to add to the variety, if not always to the effectiveness, of physicians' remedies, to enter ultimately into the trade and commerce of many nations. The flow of native plant products has not ceased even to this our day and time. How interesting were the journies and adventures of these men! How great their contributions to the scientific knowledge of a vast area! How important their findings, for plant life is as important as soil or water, land or sea, for does it not carry in itself the very basis for the existence of all life? Yet how little is known of those who have made present day knowledge of our plants possible. They have gone their way unnoticed, unrecorded, and unpraised. Is it not strange that the following of peaceful pursuits, important though they may be in their relation to human progress and their effects on human destinies, makes no impression on the passing throng? Seldom are monuments erected to the memory of those who have blazed the way into unknown regions of scientific knowledge. History records the lives of statesmen, of warriors, even of politicians. It records tremendous battles where thousands died, but history has taken little note of painstaking endeavor, of patient toil, of long years of research, and of brilliant successes in scientific fields. There has been nothing spectacular about the goings and comings of such men; they have not caught the public fancy; they have made neither the pages of news nor of history. Yet to such we owe our present day knowledge of the plants of this southeastern area, in which Florida is included. Their explorations began in 1722 and cover a period down to date of a little more than two centuries.

Then who were these men? Whence came they and what did they do? Unfortunately, for reasons already given we know too little about them. I see them in those distant days following dim Indian trails, making their way through unbroken wilderness, plunging through rank swampy growths, crossing streams and rivers on frail rafts, lost betimes, soaked by rain and chilled by piercing winds, sick and weary, yet led onward into the unknown by that peculiar, insatiable desire to find the new and the strange, and so to add their modicum to human knowledge.

The first of their number to come into this area of ours was Mark Catesby, who was born at Sudbury, England, in 1679. Some time before he was 40 years old, he made a trip to Virginia where he spent seven years and this led him to want to see more of the plants of America. So he came to Charleston in 1722 and for the next 25 years or so collected and painted plants and animals in South Carolina, Georgia, Florida, and the Bahamas. He wrote and illustrated the "Natural History of Carolina, Florida and the Bahama Islands," which comprised 11 numbers published from 1730 to 1748. This was completed shortly before his death December 23, 1749, in London. His "Natural History" is an interesting and valuable work; the plant descriptions are in French and English. Each plant illustrated is accompanied by an illustration of some animal such as a bird, a turtle, or a snake. His contribution to the biological knowledge of the area in which he worked was very material not only in itself, not only in his publications, but because he fired the imagination and lit the interest of those who came after him.

Next came Thomas Walter, also from England. Hampshire was his native home, where he was born about 1740. He came to South Carolina as a young man and settled in St. Johns Parish, near Charleston, where he died in January, 1789. The garden which he established has now gone back to a wilderness. It was perhaps the first botanical garden in America. In the British Museum there is a collection of dried plants made by Walter in the years 1786 to 1788. These are mounted in a large book of blank pages, many different kinds on a sheet, well preserved and in good condition to this day. He wrote the "Flora Caroliniana," a monumental work when we consider the difficulties under which it was written. On going through a list of the plants of this general region, one is struck by the number of species for which he is authority. *Smilax Walterii* was named for him, and many other plants besides.

John Ellis, born in Ireland about 1710, became a London merchant, made a fortune and used his wealth on plants, explorations and collections. He was appointed Agent for the King of England in 1764 and later went to Dominica in 1770. He imported into England many specimens of plants. He was a corre-

spondent of Linneus and of Doctor Garden, of Charleston, South Carolina, who was also interested in plants. He died in London in October, 1776.

Outstanding among all the men who came into this southern region were the two Bartrams, John and his son William. Between 1765 and 1778 they made several trips through the Carolinas, Georgia and Florida. They explored the St. Johns River to its source. John Bartram was born near Darby, Pennsylvania, March 23, 1699, and died at Kingsessing, Pennsylvania, September 22, 1777. All the way from the Canadian border to the headwaters of the St. Johns River he collected plants over a period of many years. He was responsible for the introduction into England of the bush honeysuckle, fiery lilies, mountain laurel, dog-tooth violet, wild asters, gentian, hemlock, red and white cedar and sugar maple. His work was followed by his son William, who was born at Kingsessing, February 9, 1739, and died at the same place July 22, 1823. He accompanied his father to Florida in the years 1765 and 1766 and lived in Florida on the St. Johns River somewhere north of Palatka during parts of the years 1766 and 1767. From 1773 to 1778 he was engaged in botanical travels in Carolina, Georgia, and Florida. One of the most interesting travel works, in which he deals with the landscape, plants, animals, and peoples, came from his pen. "Travels Through North and South Carolina, Georgia, East and West Florida," was published in Philadelphia, 1791. It was followed by an English edition, published at London, 1794, and quite recently has been reprinted here in America. It is a fascinating book.

One of the interesting episodes in connection with William Bartram's plant explorations was a request which came to him from Sir Joseph Banks, President of the Royal Society, who is said to have offered him for every new plant he could find the sum of one shilling. To this William Bartram replied that "there are not over 500 species altogether in the provinces of Virginia, North Carolina, South Carolina, West and East Florida, and Georgia, which, at one shilling each, amounts only to L 25—supposing everything acceptable. It has taken me two years to search only part of the last two provinces, and find by experience it cannot be done with tolerable conveniency for less than L 100 a year, therefore it cannot reasonably be expected that he can accept the offer." While from an economic point of view his position was eminently correct, how little did he realize what treasures lay beyond his sight.

Andre Michaux, the French botanical explorer, was born March 7, 1746, at Satory near Versailles and from 1786 to 1796 he collected plants in the United States for the French government. He worked all the way from Hudson Bay to Florida and

from the Atlantic Ocean as far west as the Mississippi River. He published a flora of North America, "Flora Boreali-Americana," on which work his son was co-author. The son, Francois Andre, also explored in America from 1785 to 1790 and made his headquarters at Charleston. There he started a garden to which plants were brought and established that they might develop good root systems and be in proper condition for forwarding to France. As much as anyone else, the younger Michaux added to the wealth of Florida plants in France. From 1806 to 1809 he worked from Georgia northward to Maine and westward to Ohio. He returned to France in the latter year and devoted himself to the cultivation of the materials which he had collected. He died at his estate near Point Toise, France, October 23, 1855. These two men were more particularly interested in woody plants, trees particularly, and added greatly to our knowledge of the tree flora of the Southeastern states.

Two Scotchmen, John Fraser and his son John, from Scotland, were interested in Florida plants and did much to assist Walter in the publication of his *Flora Caroliniana*. Indeed, it is understood that many of the plants described by Walter were collected by the Frasers. Their travels terminated with the return to England of the younger man in 1810.

These sketches bring us down now to more modern times and to those who were in some ways more intimately associated with Florida plant explorations. Although he spent but a short time in Florida, 1830 to 1837, Hardy Bryan Croom made a lasting impression upon our knowledge of the plant world of the Apalachicola region. Croom came to Florida from North Carolina. He was a graduate of the University of North Carolina and was born in Lenoir County, 1797. About 1832 he rented a plantation in Florida on the west bank of the Apalachicola River. Here he discovered *Croomia*, which was named for him, the interesting isolated *Torreya taxifolia* and made a careful study of the native pitcher plants. Unfortunately Croom's life was brought to an untimely end in a shipwreck near Cape Hatteras where he perished with his wife and three children. On the grounds of St. Johns Episcopal Church, Tallahassee, Florida, there stands a monument to his memory. Part of the inscription on this monument reads:

AMIALE WITHOUT WEAKNESS	LEARNED WITHOUT ARROGANCE
WEALTHY WITHOUT OSTENTATION	BENEVOLENT WITHOUT PARADE

He was associated for a time with Doctor Chapman and the two had planned to make a careful and thorough exploration of Florida. This plan, however, was never realized and Doctor Chapman was left to study Florida plants without his assistance.

Dr. Alvan Wentworth Chapman must be regarded as our own botanist because he lived and worked in Florida for so many

years. Born in 1809 at Southampton, Massachusetts; graduated from Amherst in 1830; taught in a private family at Whitemarsh, Savannah, 1831-1833; became principal of an Academy at Washington, Georgia, in 1833, and remained there until 1835. Studied medicine, moved to Quincy, Florida, in 1835 and began his medical practice. In 1837 he moved to Marianna where he lived for a short time, returned to Quincy, and finally located in Apalachicola in 1847 where he continued the practice of medicine and resided until his death in 1899. Chapman's "Flora of the Southern United States," published in 1860, printed in New York City, was, for more than 40 years, our manual of the plants of this region. Though dated in 1860, Doctor Chapman did not see a copy of his work until after the War Between the States was over, and it was due to the interest of Dr. Asa Gray that the plates from which the work was printed were preserved during that troublous period. This Manual ran through three editions. The second was issued in 1883; the main portion of this volume was the same as the first, but new plants were added in a supplement and later a second supplement was included. This second edition with two supplements is comparatively rare and is a collector's prize. The third edition was issued in 1896, three years before his death in 1899. Doctor Chapman added many new species to the lists of Florida plants, among which may be mentioned in passing *Zephyranthes Simpsonii*, *Viburnum densiflorum*, *Andropogon maritimus*, and *Salvia Blodgettii*. The whole number is very considerable. A genus of mosses, *Chapmannia*, was named for him. Doctor Chapman was a contemporary of Dr. Asa Gray and Dr. John Torrey. He carried on a wide correspondence with botanists both in America and in Europe. Many interesting stories are told of his life and work. It may not be out of place to relate a few of these, for they are at least of human interest.

He was an unusual and interesting character. He stood over six feet, erect, dignified and handsome, hard and stern, with a strong profile and snow-white hair. In his late years he became very deaf, which affliction he said was not entirely detrimental because, "if I can't hear people's groans they won't send for me." He admitted that except for easing a soul into or out of the world he had done his best practice with hot baths and bread pills. He strongly believed in fresh air and sunshine.

Doctor Chapman was an ardent Union man and his wife was a Southerner from New Bern, North Carolina. About the war they could not agree, so they separated for its duration and she went to live in Marianna. They never saw each other for four years. He heard from her once. When the war closed she returned. When I visited the little graveyard in Apalachicola to photograph his tomb, I found at the foot of the grave two little

Confederate flags. Miss Winifred Kimball, who accompanied me and who had known the doctor intimately for many years, said, "I believe he would turn over in his grave if he knew those flags were there." Because he favored the Union his life was constantly in danger, and whenever the guerrillas overran the town they raided his drugstore every time. Then he would betake himself to Trinity Episcopal Church and hide there until they left. There were cushions in his pew, for, as he said, "If I must hide, I decided I might as well be comfortable." Doctor Gray, America's most famous botanist, came to Florida to visit Chapman, who had been writing him about a new rhododendron he had found. The two went out to where it grew. Kneeling beside it, Doctor Gray examined it carefully, then rising and extending his hand, said, "You are right; I never saw this species. I congratulate you on *Rhododendron Chapmanii*." And so it was named for Chapman.

He was an associate of Dr. John Gorrie, the first to make ice artificially. When asked how much Gorrie made from his invention, Chapman replied, "Relatively nothing. He was no business man, was Gorrie. If he had been he never would have invented artificial ice."

Coming down to our own time, tribute must be paid to the indefatigable work in the field of Florida botany carried out by Dr. John K. Small over a period of 35 years. Every year from about 1900 up to the present time, Doctor Small has visited Florida once or more. The details of his excursions are set forth in some 90 papers. In 1903 he published his voluminous work entitled, "The Flora of the Southeastern United States." This was followed by a second edition in 1913 and in 1933 his "Manual of the Southeastern Flora" appeared. This last volume has brought down to this date our knowledge of Florida plants. The tremendous amount of work done by Doctor Small can scarcely be appreciated, except by those who have been associated with him from time to time in connection with his investigations. His plant collections are in the herbarium of the New York Botanical Garden. The number of new forms named and described by Doctor Small is very large and, although there undoubtedly remain new plants to be found, no one will ever equal the number from this region to which Small's name is attached as author. Although he has not visited Florida this year, it is hoped that his visits to the state are not yet ended. Recently the herbarium of the Florida Experiment Station has been favored with a collection of 1,059 specimens from Small's collections—a priceless series of material that has journeyed away from the state and then returned.

While by far most of the plants native to Florida are known, our knowledge of where they are is most incomplete. Information

covering their distribution is lacking. Local floras covering definite areas are needed. Lists of plants authenticated by herbarium specimens will be of great value. Representative collections of good herbarium material are greatly to be desired and they are needed in the several educational institutions of the State.

The field is wide open for ecological studies to be carried out on a well rounded basis in which undertaking at least the botanist, the soil scientist, the chemist and the climatologist should join. There is need for greatly expanded plant interest all over the State, which interest can be aroused best in our grammar and high schools. To these ends the Florida Academy of Sciences may well give help.

There remains much still to be done in the botanical fields in Florida and it is hoped that the years to come may add further to our knowledge of this vast plant area.

LIMITATIONS OF THE PROBABLE ERROR OF ESTIMATE IN PREDICTING THE COURSE OF HUMAN BEHAVIOR

CHRISTIAN PAUL HEINLEIN

Florida State College for Women

THE PURPOSE OF this paper is to describe the primary theoretical assumptions which must be satisfied to render valid the probable error of estimate of a raw datum, score or unit-value taken from an empirical distribution.

In correlating two variables, such as intelligence (in terms of composite scores obtained from some standardized intelligence test) and scholastic achievement (in terms of point grades), investigators have attempted to predict the level of an individual in a second array from a knowledge of his level in a first array with which the second array is correlated by a definite amount. To describe this situation in another way, we may say that one of the purposes in correlating arrays is to demonstrate the degree of concomitance and mutual dependence of scores in two arrays considered representative. When two arrays of scores are correlated, the scores in one array are treated as a function of the scores in the other array. If we can demonstrate that the relationship between the two arrays is rectilinear, then in accordance with the practice of predicting in terms of the regression equation, we may assume any \bar{y} level to be a certain multiple of the corresponding \bar{x} level when each is measured from the mean. This multiplier, as you know, is the regression coefficient "beta"

and indicates the slope of the line that best fits the trend of paired levels. We may refer to the regression coefficient of y on x as the slope that the straight line makes with the x -axis when it passes through the successive x -values in such a way as to fit best the corresponding y -values. We may refer to the regression coefficient of x on y as the slope that the straight line makes with the y -axis when it passes through the successive y -values in such a way as to fit best the corresponding x measures. When these coefficients are taken as deviations from the means of their respective arrays, the coefficient of regression of y on x becomes the ratio of the standard deviation of y to the standard deviation of x times the magnitude of the coefficient of correlation. In order to compute x in terms of y , we may interchange y and x in the ratio and obtain the regression coefficient of x on y .

In order to develop the regression equation in deviation form, we should recall the development of "r" as the tangent of the angle that the regression line makes with the X -axis when the variabilities in the two directions have been equalized. If "beta" represents the slope of the line required when the sum of the squares of the errors is a minimum, and x a given value in deviation form in the first array, y a corresponding value in the second array, and \bar{y} the level this y value must reach in order to fall on the regression line, then by definition of "beta," $\bar{y} = bx$. We revert to this equation for the purpose of substituting it in the value obtained for b_{yx} . This gives us our regression equations in deviation form—(project slide # 1 on screen)

$$(1) \quad \bar{y} = x(b_{yx}), \text{ where } b_{yx} = r_{xy} \frac{\sigma_y}{\sigma_x}$$

$$(2) \quad \bar{x} = y(b_{xy}), \text{ where } b_{xy} = r_{xy} \frac{\sigma_x}{\sigma_y}$$

From the first equation it has been the practice in mental measurement to predict the most probable y value of individual behavior from a known x value, and from the second equation to predict the most probable x value of individual behavior from a known y value. If we wish to translate the regression equation in deviation form into a regression equation in raw datum form, we simply substitute $(X - M_x)$ for its equivalent x , and $(Y - M_y)$ for its equivalent y , the M 's being the respective means. Thus, the regression equation in score form becomes—(project slide # 2 on screen)

$$\bar{Y} = (Xb_{yx}) + (M_y - b_{yx}M_x)$$

where $b_{yx} = r_{xy} \frac{\sigma_y}{\sigma_x}$; M_x = mean of first variable; M_y = mean of second variable; X = known score.

In empirical situations where the relationship is other than one, we know that not all y values that correspond to x values fall on the regression line; the x and y values scatter above and below such a line and may be regarded as misses or errors. The standard error of estimate is simply the standard deviation of these misses above and below the regression line. This value is best expressed by the formula—(project slide #3 on screen)

$$\sigma_{yx} = \sigma_y(1 - r_{xy}^2)^{\frac{1}{2}}$$

The probable error of estimate, $P.E._{yx}$, is equal to $0.6745\sigma_{yx}$.

In order to illustrate the practical application of the formulas presented, let us consider a concrete problem as described by Charles C. Peters. The mean of intelligence test scores is given as 100 with a standard deviation of 30; the mean of "point-averages" correlated with the intelligence test scores is 1.40 with a standard deviation of .60. The Pearson " r " between the two variables is .40. A certain student by the name of William makes a score of 82 in the intelligence test. What may he be expected to achieve in terms of a point average? Substituting the cited values in the regression equation in score form by solving we obtain 1.256.

$$\bar{Y} = .40 \frac{.60}{30} 82 + (1.40 - .40 \frac{.60}{30} 100)$$

$$\bar{Y} = .656 + 1.40 - 0.80 = 1.256$$

How accurate is this prediction of 1.256? This question is answered by the probable error of estimate.

$$\begin{aligned} \sigma_{yx} &= .60(1 - .40^2)^{\frac{1}{2}} = .60(1 - .16)^{\frac{1}{2}} \\ &= .60(.84)^{\frac{1}{2}} = 0.55 \end{aligned}$$

$$P.E._{yx} = .6745(0.55) = 0.371$$

The computed probable error of estimate is .371. This last value (.371) means that the chances are 50 in 100 that William's actual point average will not differ from his predicted one by more than .371. However, we must not forget that the chances are 50 in 100 that the score will be missed by more than that amount. If it is our desire to be practically certain within the limits of four probable errors, the limits of our estimate will extend so far that a given prediction becomes practically meaningless. It becomes at once obvious that a very high " r " is demanded for the purpose of reducing the element of chance in the prediction of a given score. The coefficient of alienation, which is part of our standard error of estimate, will indicate the absence of relationship between the two correlated variables, whereas the coefficient of efficiency of our prediction. Judging by the kind of conclusions drawn from coefficients of correlation, few investigators seem to realize that under the most ideal conditions of correlation, when

mutual dependence between the variable can be empirically demonstrated, in a prediction based on an r of .95 there remains 31% of the element of chance or that percentage of unknown factors operating. Were this fact generally recognized, we should not be obliged to confront the far sweeping conclusions concerning the so-called "significant" reliabilities and validities of test scores based on r 's between .50 and .85. Yet many testers affirm the "significant value" of intelligence test scores as predictive indices of scholastic achievement in spite of the median efficiency of only 4 per cent between the Thurstone intelligence IV test and scholastic success as indicated in 43 institutions and in spite of the long list of institutional correlations cited by Boynton in which no single r between intelligence and scholastic success ever reaches 50% efficiency.

But let us assume that an r between two variables *is* statistically significant so that the degree of chance is reduced eighty-five per cent. Such significance would demand an r of .99. In the light of this r , is it a logically sound and scientifically valid procedure to predict an x score in terms of a known y score? The answer to this question depends on our concept of correlation. We might answer "yes" if we can demonstrate that the criteria of mesokurtosis, homocedasticity and representativeness have been satisfied in the correlated arrays, if further we can demonstrate that the moments within the correlational frame are dynamically interacting and causally efficacious to determine the status of any given value in either axis. Unfortunately, most empirical distributions are not rectilinear and hence not resolvable in terms of " r ". Investigators are not prone to indicate the kurtosis or skewness of their distributions, nor are they inclined to define the criteria of representativeness for distributions considered statistically reliable. Instead of moralizing the curve of errors and instead of forcing every conceivable variety of psychological and educational data into this ideal curve, it behooves the present and future investigators to discover the mathematical characteristics of empirical curves that most adequately satisfy specific distributions of experimentally isolated qualitatively homogeneous data. The chief failure in modern educational research is the failure to distinguish between empirical probability and theoretical probability.

Perhaps the most glaring abuse of the probable error of estimate in predicting a single score or value is found in the misinterpretation that the method of rectilinear correlation is identical with the method of concomitant variation. The method of correlation when applied to the data of mental testing is *not* the same as the physical method of concomitant variation. In the latter method, a unit event A is varied to determine its effect upon a macroscopically constant unit event B . In this method,

an interacting dynamic concomitance provides the specification of a certain degree of causal efficacy. In the method of correlation, any degree of relationship may be a function of incidental concomitance. The relationship between intelligence scores and scholastic achievement may be purely incidental, and not causally efficacious. We may be quite certain that the product moments within the correlational frame involving these two variables are almost purely incidental. The score of student *A* within the frame of correlation is causally independent of the score of student *B* unless student *B* is socially affecting the response of student *A* to the test in question. The size of the coefficient of correlation is never a certain index of causal efficacy or mutual dependence. It would appear that the relationships indicated by the great mass of educational and social data are purely incidental and hence practically useless in the accurate prediction of future events.

The following table (project slide #4 on screen) reveals at a glance the percentage of relationship or overlapping between two things in terms of ascending values of "*r*", the coefficient of correlation. Observe that the acceleration in percentage of relationship between an *r* of .95 and 1.00 is greater than that between zero and an *r* of .70. Note also that the acceleration in percentage of relationship between an *r* of .99 and 1.00 is greater than that between zero and an *r* of .50. To the student who has regarded the coefficient of correlation as a percentage of relationship, the above related facts may prove startling and unbelievable.

Coefficient of correlation " <i>r</i> "		Percentage of relationship
.00	=	.00
.25	=	.03
.50	=	.13
.70	=	.28
.75	=	.33
.80	=	.40
.87	=	.50
.90	=	.56
.95	=	.68
.96	=	.72
.97	=	.75
.98	=	.80
.99	=	.85
.995	=	.90
1.00	=	1.00

Let it be remembered that the deviations within a correlational frame are static and fixed. One cannot vary at will his degree of intelligence to determine the effect the variation will have on scholastic success. The assumption that the moments generated by values in the *X* and *Y* arrays are dynamically efficacious to produce a single *X* value when a corresponding *Y* value

is known, cannot be justified when we pass from one correlational frame to another. Standardization of a given level of achievement in terms of some second criterion considered valid rests on the assumption of representative behavior wholly static in character and unaffected by time. The pseudo-mathematical techniques inherent in scaling devices that lead to the hypostatization of correlated variables are perpetuated through the act of standardizing.

When guidance experts predict the course of individual behavior in the light of some mental test score, they assume that the score expresses a psychological function or functions on which future behavior of a discriminable quality depends. They fail to comprehend that the gross score is a momentary transverse expression of a complex of intellectual judgments, the effective dependability and fidelity of which are unknown. It does not take a genius to perceive that the future course of life may assume one of a large number of forms and that it is not statically determined by any snap-shot statistical transection of some immediate narrow field of arbitrarily selected intellectual judgments. A given set of intellectual judgments may function for a given organism in as many different ways as there will be different effective future environments. The experimentalist's description of the future course of life by means of the probable error of estimate based on qualitatively heterogeneous levels is about as reliable as the predictive imagery of the crystal gazer or the fanciful descriptions of the astrologer.

AN EXAMPLE OF THE QUANTITATIVE METHOD IN SOCIAL PSYCHOLOGY

CHARLES I. MOSIER¹

University of Florida

THIS PAPER represents the preliminary report of an effort to apply rational quantitative methods to a problem in the field of social psychology. The temporal course of fads and popular fashions, representing as it does the reactions of individuals to certain stimuli, is a legitimate problem in the field of social psychology, however trivial it may be deemed. The growth and decline in popularity of any stimulus represents the collective judgments of a large group of persons, and those judgments are

¹In presenting this paper, the writer wishes to acknowledge the assistance given by Professors C. G. Phipps and H. H. Germond of the Department of Mathematics of the University of Florida.

Fig. 1

Popularity Function
 Title: Robins and Roses
 Functions: $\bar{P} = \frac{c}{k} \left[t + \frac{1-e^{-kt}}{k} \right] + P_0 e^{-kt}$
 $k = -0.06$
 $c/k = 13.2$
 $P_0 = -1.8$
 X Obtained ranks
 • Calculated ranks

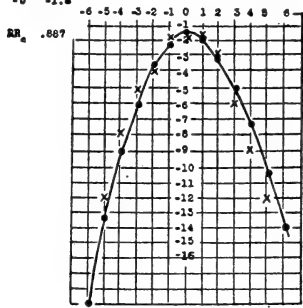

Fig. 2

Popularity Function
 Title: When I'm With You
 Functions: $\bar{P} = \frac{c}{k} \left[t + \frac{1-e^{-kt}}{k} \right] + P_0 e^{-kt}$
 $k = -0.70$
 $c/k = -1.25$
 $P_0 = 0.78$
 X Obtained ranks
 • Calculated ranks

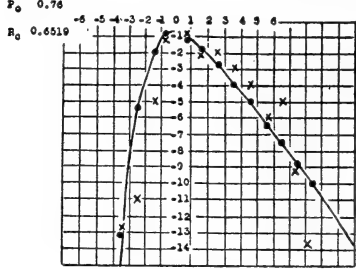

Fig. 3

Popularity Function
 Title: All My Life
 Functions: $\bar{P} = \frac{c}{k} \left[t + \frac{1-e^{-kt}}{k} \right] + P_0 e^{-kt}$
 $k = 0.05$
 $c/k = -0.576$
 $P_0 = 3.00$
 $R_0 = 0.786$
 X Obtained ranks
 • Calculated ranks

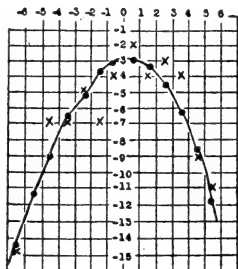
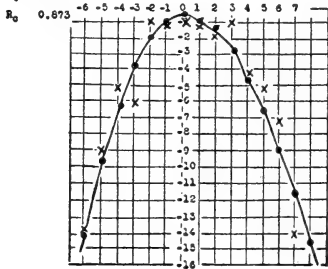

Fig. 4

Popularity Function
 Title: Is It True
 Functions: $\bar{P} = \frac{c}{k} \left[t + \frac{1-e^{-kt}}{k} \right] + P_0 e^{-kt}$
 $k = -0.11$
 $c/k = -5.346$
 $P_0 = -0.50$
 $R_0 = 0.673$
 X Obtained ranks
 • Calculated ranks



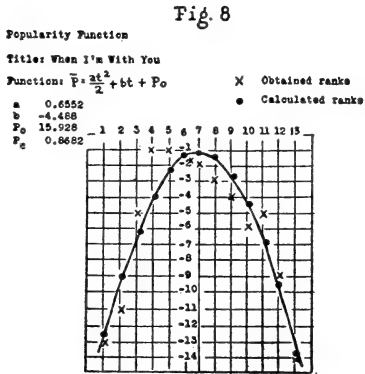
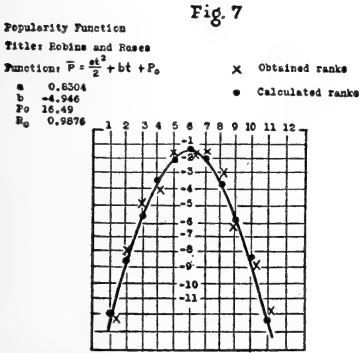
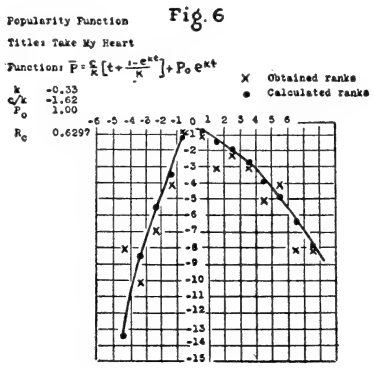
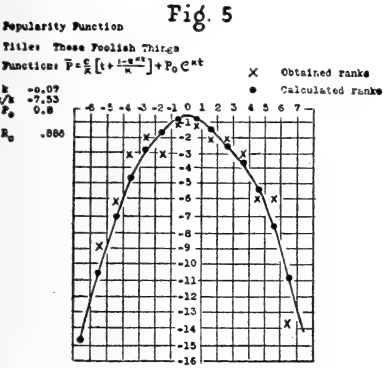

Fig. 9

Popularity Function

Title: All My Life

Function: $\bar{P} = \frac{at^2}{2} + bt + P_0$

X Obtained ranks
● Calculated ranks

a 0.5444
b -4.278
P₀ 19.950
P₀ 0.8269

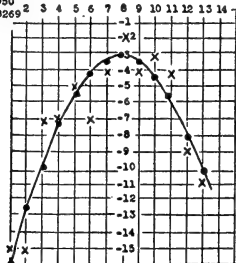

Fig. 10

Popularity Function

Title: Is It True

Function: $\bar{P} = \frac{at^2}{2} + bt + P_0$

X Obtained ranks
● Calculated ranks

a 0.590
b -4.482
P₀ 37.40
P₀ 0.9168

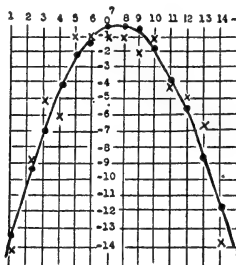

Fig. 11

Popularity Function

Title: These Foolish Things

Function: $\bar{P} = \frac{at^2}{2} + bt + P_0$

X Obtained ranks

● Calculated ranks

a 0.5990
b -4.6292
P₀ 18.2888
P₀ 0.896

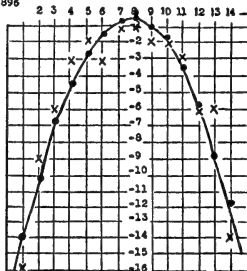

influenced by the social situation of the moment. These changes in total popularity seem to exhibit certain regularities which indicate the possibility of quantitative treatment. We see a fad begin, sometimes slowly, sometimes suddenly, reaching a height of popularity, and then beginning a fall from grace which may be so slow as to be imperceptible over a period of years, or so precipitous as to carry the fad from sight, and even from memory, within a month or two.

As examples of this phenomenon of the growth and decline of popularity, the "popular" songs of the day have certain advantages as objects of study. The course of their life histories is relatively brief; the development of their popularity is more truly a matter merely of liking or disliking, uncomplicated by the pressure of advertising, by the necessity of making any definite action, such as purchasing, or by the related factor of saturation of the potential market. (It is conceivable that a fad might be at its peak popularity after the potential market had been saturated and no more sales were being made.) An additional point in favor of the study of the popularity of songs is that, as a result of the advertising campaign of a popular cigarette, the fifteen most popular songs of the week, determined on a nation-wide basis, are available to test such hypotheses as may be devised.

Before going farther, it should be mentioned that this study is not presented as a finished product, and that its chief claim to interest lies in the opening of the field to quantitative methods and the demonstration that such methods are likely to prove fruitful, rather than in any specific results. Certain hypotheses as to the laws underlying the growth of popularity have been tested, others are still being tested. Certainly the most satisfactory set has not been found. Before conclusions of significance are reached two conditions must be met that have not been attained: (1) more, and more varied hypotheses must be tested, and the consequences of each must be investigated more fully; (2) more, and more adequate data must be assembled to enable us definitely to verify or reject the hypotheses tested.

If the popularity of a song be considered it would seem that what we understand by popularity is the total number of individuals who like that song at a certain time. This, in turn, is a function of two factors—the number of people who hear the song, and the proportion of those hearing it who react favorably. Now the first of these factors depends on the popularity already attained—the more popular a song becomes, the more it is played, sung, hummed, or whistled, and the more people hear it. Songs of this type, however, do not "wear well," and after a person has heard it several times (in some cases, once) he is less likely to like it than formerly. Thus, as a first approximation, we may express

the rate of change in the popularity of a song as the sum of two components (it would appear more profitable to consider the product of the two components, and this is now being investigated). The first of these components makes for an increase in popularity proportional to the popularity already attained, the other causes a decrease with increasing time. (More exactly, the decrease is due to a large number of unknown factors whose average varies as a function of time.) Writing this hypothesis as a differential equation, we have:

$$(1) \quad dp/dt = kp - ct$$

where p is some measure of popularity, t is some measure of time, k is a constant indicating the "catchiness" of the song, and c is a function of its "wearing qualities." If this equation be solved for the function $p(t)$, we have (omitting the intermediate steps involved in the solution):

$$(2) \quad p = c/k(t + \frac{1 - e^{kt}}{k}) + p_0 e^{kt}$$

This, then, is the form in which the hypotheses outlined above may be tested.

The ranks of the fifteen most popular songs of each week were secured for the period beginning April 13, 1936, and ending October 19, 1936. Only those songs on which data were complete—from the first to the last appearance among the first fifteen—were retained. Songs on which fewer than ten observations were available were also eliminated.

In considering the data available, certain limitations must be pointed out. In the first place, time is measured from an arbitrary origin—the time of the first appearance of the song among the fifteen most popular. Nothing is known of the time or the popularity before this. The data are limited to the very peak of the curve and no information is available concerning the early stages of growth and the later stages of the decline in popularity—periods crucial for the test of a particular hypothesis. A second objection is that ranks are not units, and a shift from thirteenth place to twelfth place, for example, may not be equivalent to a shift from third to second place, though we are forced to treat it so. Furthermore, the rank of a song is determined by the quality of the other songs in vogue, so that a mediocre song, coming at a time when it is compared with a group of poor songs, will receive the same rank as an excellent song compared with a group of good songs.

Although it is true that equal differences in ranks do not ordinarily measure equal differences in the attribute ranked, this objection may be partially overcome. We may reasonably assume that the distribution of popularity of all songs at any particular

time is such that for the most popular songs, rank is a linear function of popularity. That this assumption is tenable is indicated by the consistency of the results to be reported. For this study, then, popularity may be approximated by rank. Since popularity decreases as rank increases numerically, it will be convenient to measure popularity by the negative of the rank. It will also prove convenient, in testing the hypothesis of equation (2) to measure time in weeks from the time of maximum popularity.

A procedure for fitting the curve of equation (2) utilizing first and second differences was developed, by means of which the values of c , k , p_0 , and the zero point for time might be estimated with fair accuracy. The curve-fitting procedure leaves much to be desired in economy of time, and in perfection of results, but it seems adequate to the treatment of data as rough as these admittedly are.

The results of fitting the exponential growth curve are shown in Figs. 1-5. Fig. 1 shows the observed ranks and the fitted curve for one particular song. The curve is nearly symmetrical and the fit is surprisingly close. The correlation between observed and calculated values, corrected for the number of parameters, is .89. The next figure shows the curve and the data for a second title—a curve exhibiting a rapid rise and relatively slow decline. The fit in this case is by no means as good as in the first, though still fair. The corrected correlation between observation and prediction is .66. The low correlation may be due to one or all of three factors: (1) the hypothesis does not fit the data; (2) the curve-fitting procedure is not adequate; (3) the data themselves are unreliable. The other figures show results similar to these discussed, some excellent fits by any criterion, some not so good.

Since some of the curves presented resemblances in appearance to the second degree parabola, it was decided to fit such a curve to the data. The hypothesis leading to such a curve would be that the rate of change in popularity is proportional to time, plus an original velocity. Stated as a differential equation:

$$(3) \quad dp/dt = - at + b$$

which integrates readily to give:

$$(4) \quad p = \frac{at^2}{2} + bt + p_0$$

where p , t , and p_0 have the same significance as before, a is a positive constant indicative of the "durability" of the song, and b is the number of weeks necessary for the song to reach its maximum popularity—a measure of its "catchiness".

This function has certain advantages in ease and accuracy of fitting. The resulting fits are superior to those obtained by fitting

the exponential, which may indicate that this is a better guess as to the laws underlying the growth of popularity, or that the method of curve-fitting is superior. The results of fitting this parabolic function to the data are presented in the next series of slides.

As has been mentioned, other hypotheses ought to be tested, their consequences investigated more fully, and verified by more adequate data. For example, both the functions discussed have no place where the second derivative is zero, and there are rational grounds for considering this unlikely. The restriction of the data to the central range makes it impossible to test this possible discrepancy. Again, the hypothesis that the rate is the product function of the two components kp and ct offers interesting possibilities, and a considerably safer rational basis.

What may be concluded from this investigation? Certainly not that either of the two hypotheses advanced as descriptions of the popularity function is verified. The data are too few, and too limited in range to permit of such verification. Furthermore, the data are, as has been pointed out, unreliable as measurements. The conclusion that we can draw, however, is that it is possible in the field of social psychology to formulate rational hypotheses as to the behavior of certain variables, to express those mathematically and to deduce from those hypotheses certain conclusions which admit of verification. If we find evidence of consistent behavior from data whose reliability is questionable, may we not expect that with more accurate measurements, our hypotheses will prove susceptible of exact, quantitative verification? Furthermore such a procedure will lead to the determination of constants having rational meaning, and by utilization of these constants, comparisons between songs, or even between fads, may prove both possible and enlightening.

A STUDY OF THE ARTESIAN WATER SUPPLY OF SEMINOLE COUNTY, FLORIDA*

SIDNEY A. STUBBS
University of Florida

FOR THE past ten months I have been engaged in a detailed study of the subsurface geology and the artesian water supply of Seminole County. This paper very briefly summarizes the results of the study of the artesian waters.

*Awarded the Achievement Medal for 1937.

The investigation was begun on January 1, 1937. The purpose of the survey has been to outline the area of artesian flow and the area of highly mineralized waters, and to study in detail the amount and causes of fluctuation in the artesian water levels.

Seminole County is located in the east central part of the Florida peninsula. This county was organized from a part of Orange County in 1913. The county comprises an area of 205,440 acres or 321 square miles.

The county seat of Seminole County is Sanford, located in the northwestern part of the county on Lake Monroe. The 1935 state census gives it a population of 10,903. The population of the county by the same census is 22,192.

The raising of celery and citrus fruits is the chief industry of the county. The celery farms occupy the lowlands in the vicinity of Lake Monroe and Lake Jessup, and a considerable area south of Oviedo in the south central part of the county. Most of the citrus groves are in the hill country in the south and western part of the county. The area under actual cultivation in truck crops covers approximately 6,000 acres of irrigated land. The water used for irrigation of the truck lands is obtained from artesian wells. Lake water is usually used for grove irrigation.

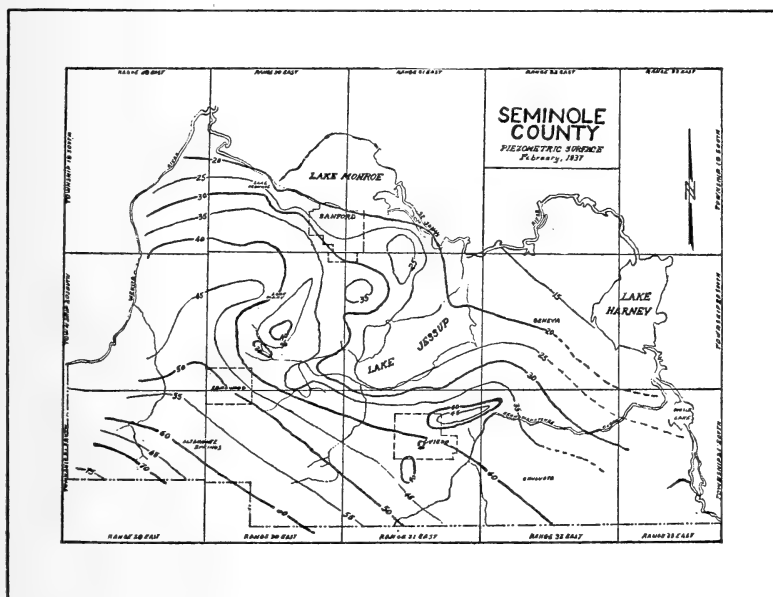

Slightly more than two hundred wells have been under observation, and monthly readings have been taken on key wells. The chloride content has been determined upon a much larger number. The readings of the pressure head of flowing wells have been made with a hose and measuring rod in all practical cases. On flowing wells where the pressure was too high to read by means of a hose, a gauge, regularly checked against a hose, was used. Non-flowing wells were checked by the wetted tape method. The elevations of the wells have been determined by precise levels run from United States Coast and Geodetic bench marks and from elevations established by the county engineering department corrected to Coast and Geodetic elevations. Elevations on a few of the outlying wells were obtained by means of an aneroid barometer.

GEOLOGY

The geologic formations of the county are shown on the chart. Of these formations, four have significance as artesian water horizons; the Coskinolina zone and the Ocala formation of Eocene age, the Hawthorn formation of Miocene age, and the Caloosahatchee marl of Pliocene age. The most important of these are the Coskinolina zone and the Ocala formation.

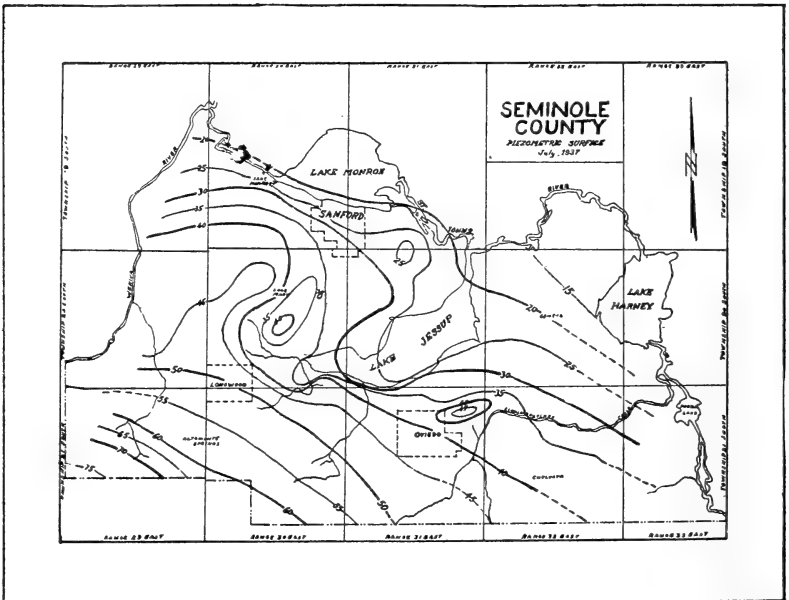

TABLE I.—GEOLOGIC FORMATION IN SEMINOLE COUNTY.

AGE	GROUP	FORMATION	THICK- NESS	CHARACTER
Recent and Pleistocene			0-60?	Undifferentiated sands and soils.
Pliocene		Caloosahatchee marl	0-70	Marl, shell and sand. Minor artesian aquifer.
Miocene	Alum Bluff	Hawthorn	0-70?	Interbedded clay, marl, and sandy limestone. Important artesian aquifer.
Eocene		Ocala limestone (of Jackson age)	0-200?	Limestone. Important artesian aquifer.
		Coskinolina zone	?	Limestone. Important artesian aquifer.
*Eocene and Cretaceous				Undifferentiated sediments.
*Paleozoic or older				Mica schist, etc. Metamorphic basement.

*After Cooke, C. W., and Mossom, Stuart, *Geology of Florida; Florida Geol. Sur. Twentieth Ann. Rept.*, p. 40, 1929.

COSKINOLINA ZONE

I first suspected the presence of an aquifer older than the Ocala from a study of the chloride content of the waters. Well cuttings from areas where the chloride content was high revealed a predominance of the Foraminifer *Coskinolina* and an absence of typical Ocala Foraminifera. I tentatively assigned this zone to the upper part of the Middle Eocene. Through the cooperation of the Florida Geological Survey, it has been possible to have these samples studied by Mrs. E. R. Applin, a micropaleontologist of Ft. Worth, Texas. Mrs. Applin suggested that this limestone is probably Upper Claiborne in age.

This zone lies directly below the Ocala formation. The contact between the two is unconformable, and the Coskinolina zone

was deeply eroded before the deposition of the Ocala formation.

The Coskinolina zone is composed of beds of relatively soft and very hard granular limestone ranging in color from white to rich cream and buff. The well cuttings very often closely resemble brown sugar in color and texture. Numerous cavities occur through the formation. G. M. Arie, a driller at Oviedo, has reported a particularly large cavity in a well drilled for the Lake Charm Fruit Company at Lake Charm northeast of Oviedo. According to the driller, he passed through a fairly hard rock at 340 feet, and from there to 390 feet the drill was hanging free, indicating an opening fifty feet in depth. This cavity probably occurred in the Coskinolina zone.

The Foraminiferal fauna of the Coskinolina zone is rich and distinctive. The following data as to families represented have largely been derived from a study of Mrs. Applin's logs. The family Valvulinidae is represented by at least five genera and an undetermined number of species. The identified genera are *Coskinolina*, *Lituonella*, *Valvulammina*, *Cribobulimina*, and *Arenobulimina*. Of these, *Lituonella* and *Coskinolina* are most common. The Textulariidae are represented by *Textularia*, *Climacammina*, and *Bigenerina*. Three Miliolidae occur commonly, *Quinqueloculina*, *Triloculina* and *Massilina*. Two Peneroplidae occur frequently; *Spirolina* and *Peneroplis*. There is also an abundance

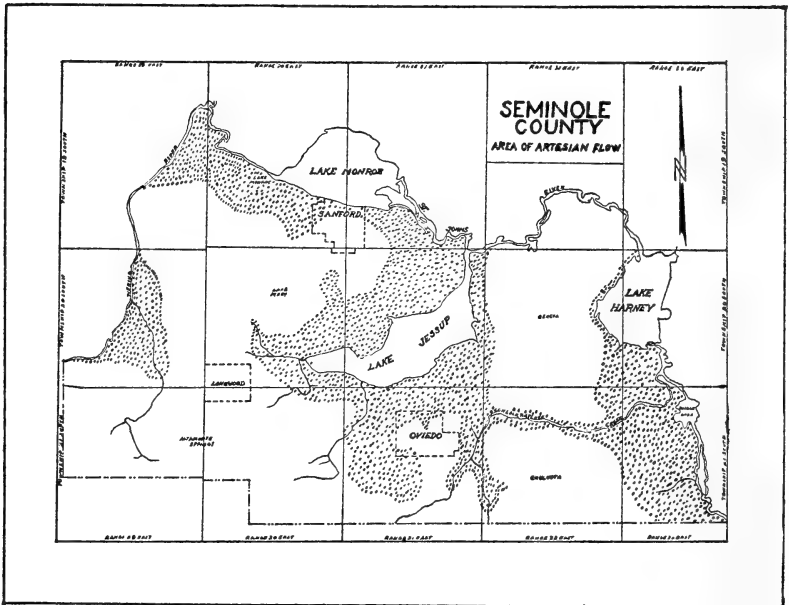

of other species which seem to be characteristic of this zone, some of which do not appear to have been described.

The area in Seminole County that is drawing its water from the Coskinolina zone is confined to the region between Lake Jessup and Lake Monroe, an area almost to Oviedo around the east side of Lake Jessup, and a strip extending east along the St. Johns River to the edge of the county. This zone yields a large quantity of water; but all wells that are definitely known to be flowing from the Coskinolina zone are brackish.

THE OCALA FORMATION

The Ocala formation lies unconformably upon the Eocene Coskinolina zone. As the Ocala occurs in Seminole County, it is a white to light-cream-colored limestone. The formation is generally soft and very porous. Cavities of varying depths are often struck during drilling.

This formation is relatively thin in Seminole County, attaining its greatest thickness to the south and west, thinning rapidly to the north and northeast. The formation is not thought to exceed two hundred feet in this county.

The fauna of the Ocala is rich. *Gypsina globula*, *Operculina ocalana* and *Rotalia* sp. (Cushman) are common. Specimens of *Lepidocyclina* are rare in the samples from wells toward the northern part of the county, but are usually plentiful toward the south and west. Species of *Textularia*, *Reusella*, *Eponides*, and various Miliolidae are abundant.

The farming districts west of Sanford and in the vicinity of and south of Oviedo are obtaining artesian waters principally from the Ocala formation, which yields a large volume of water usually low in chloride content. Toward the area where the Coskinolina zone is the principal aquifer, however, waters from the Ocala are brackish.

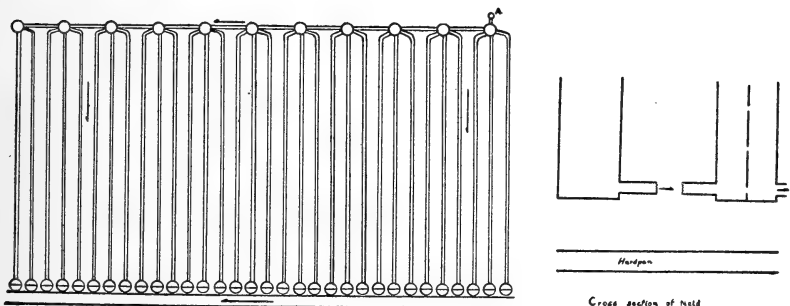

Fig. 1 Irrigation system for a five-acre tract of land

THE HAWTHORN FORMATION

The Hawthorn formation is third in importance as an aquifer. This formation underlies most of the county south and west of Lake Jessup. At one time all the county was covered by Hawthorn strata, but these have been almost entirely removed by erosion along the St. Johns River valley. The maximum thickness probably does not exceed seventy feet.

The Hawthorn formation lies unconformably upon the Ocala formation. In Seminole County it is characterized by beds of white to gray sandy limestones alternating with beds of blue-gray marl. The limestones and marls both contain a large percentage of phosphate pebbles ranging from the size of sand grains to the size of gravel. The limestone beds are usually very hard and range in thickness from one to three feet. The formation caves badly during drilling, and for this reason it has been difficult to get a very accurate picture of the formation.

The fauna of the Hawthorn formation is very poorly preserved and no identifiable invertebrate fossils have been found. Shark and fish teeth are common, however.

The quantity of water that the Hawthorn formation yields is not so great as that from the Eocene formations. A large flow of water is usually obtained at the contact zone between the Hawthorn and the underlying formation. Because water from the Hawthorn is softer than water from the Eocene limestone it has been greatly desired for home water systems. Most of the wells in the county that terminate in the Hawthorn are being used for domestic purposes.

THE CALOOSAHATCHEE MARL

The Caloosahatchee marl lies unconformably upon the Ocala formation and upon the Coskinolina zone of the Eocene in the northern part of the county, and upon the Hawthorn formation in the southern part of the county. It is probably absent along the southwestern border of the county.

This formation is well developed along the St. Johns River valley. It is known to be seventy feet thick in this region and may possibly be thicker. In the southern part of the county it is much thinner, probably not exceeding twenty-five feet in thickness.

In Seminole County, the Caloosahatchee marl is composed of beds of shell marl alternating with beds of shell and sand. The shell and sand beds are usually much thicker than the marly phase. Both of these phases are so variable, however, that it is impossible to give any general average for either.

The fauna of the Caloosahatchee marl present in Seminole County is most closely related to the Nashua phase, which is well

represented by exposures a few miles to the north in Volusia County. The mollusks *Drillia tuberculata*, *Olivella nitidula*, *Mulinia contracta*, *Phacoides multilineatus*, and *Arca camphyla* are very common Pliocene species present. Many other forms are also found. Foraminifera are plentiful. The most common forms present are *Elphidium gunteri*, *E. poeyanum*, *E. sagrum*, *E. incertum*, *Rotalia beccarii* var. *parkinsoniana*, *Discorbis floridana*, and *Cibicides lobatulus*. A particularly noticeable feature of the micro-fauna is the predominance of various species of *Elphidium*.

This formation yields a small flow of soft water, highly impregnated with hydrogen sulphide. Only a few wells are at present obtaining water from this formation, and they are all small driven wells used for domestic purposes. According to some of the older drillers of the county, however, when artesian waters were first developed in Seminole County, many of the wells were flowing from a shell bed. This was undoubtedly the Caloosahatchee marl.

PLEISTOCENE AND RECENT

The marine Pleistocene has not been identified in any well studied from this county to date. The Pleistocene and the Recent deposits are surficial sands. These sands furnish water for a large number of surface-water wells used for domestic purposes.

USES OF WATER

By far the largest percentage of the artesian water used in the county is for irrigation. Public water supplies obtaining water from the artesian formations have been developed by the city of Sanford and the communities of Lake Mary, Longwood and Fern Park. Lake Mary is drawing water from the Hawthorn formation. Sanford, Longwood and Fern Park are obtaining water from the Ocala formation.

At the suggestion of the writer, an effort has been made by C. R. Dawson, County Agent, to obtain an accurate count of the number of artesian wells on the farms in the county. This information has been assembled and supplemental data added by H. James Gut of Sanford. These figures show a total of 2,187 artesian wells. Since these figures do not include unused wells, or wells used for municipal, commercial or domestic purposes, another thousand can safely be added to the 2,187 making a total of something over three thousand wells in the county. The figures for wells on cultivated land give an average of one well to every 2.98 acres. The most common sizes are two, three and four inch wells in the order mentioned.

The common system of irrigation used in this county is unique and deserves special mention. Because the hardpan lies

within only a few feet of the surface, subsurface irrigation is very practical and is now used on most of the celery farms.

Figure 1 shows the general set-up for the irrigation of a five-acre tract of land. The well is drilled on the high corner of the field and is designated as A. This well feeds into a concrete or terra cotta standpipe which is connected to a tile main. Running from this main at twenty-foot intervals, there are lines of three-inch drain tile across the field. Where each of these lines of drain tile connects with the main there is another standpipe, so that it will be possible to plug any line of drain tile and wet only that portion of the field that requires moisture. On the outlet side of the field, the water runs from the drain tile into a sewer or ditch and at each outlet there is a standpipe with a partition through the center. This partition has holes which may be plugged and thereby the level of the water in the field is controlled. This is shown in the cross-section.

During very wet weather this irrigation tile is left open and serves for drainage. Thus the tiling serves a double purpose.

Because it is believed that the water must be kept in circulation during irrigation, this system uses an enormous volume of water.

AREA OF ARTESIAN FLOW

The area of artesian flow in the county has been carefully outlined on the accompanying map. Whether or not an artesian well will flow is dependent upon the pressure head of the water and the elevation of the land. Many attempts have been made to obtain flowing wells in non-flowing areas by the drilling of excessively deep wells. All such attempts have been unsuccessful.

Near the edges of this outlined area, there are wells that flow during very wet seasons and there may possibly be some additional areas where wells will flow, but where none have been drilled to date.

The area of artesian flow is more limited today than it was a number of years ago; and a greater constriction of the flow area is to be expected with increased development of the artesian supply in the county.

PERMANENT LOSS OF HEAD

Previous records on the pressure head of wells in Seminole County are meagre, and it is now impossible to locate most of the wells mentioned in the older reports. Therefore, much of the information necessary in formulating an estimate of the permanent loss of head that has taken place must be inferred from other sources. It has, however, been possible to find the general area of a few of the wells mentioned in the United States Geo-

logical Survey Water-Supply Paper 319. These wells have been rechecked and the following data have been obtained.

Water-Supply Paper 319, which was published in 1913, gives a head of 26 feet for a well on a farm owned by Chas. Campbell. This farm was east of Sanford, and no wells in this area now show a head of more than 16 feet. Wells owned by F. W. Mahoney in Sanford are reported to have had a head of one and one-half feet above the surface at that time. The water in these wells now stands from three to five feet below the surface.

The Fifth Annual Report of the Florida Geological Survey, also published in 1913, reports a pressure of approximately 23 feet above the surface for a well one-quarter mile west of Lake Monroe Station. No wells within this area have a pressure head of more than 18 feet above the surface today.

From these data it can be seen that there has been a minimum permanent loss of head of from four to ten feet within the flowing-well area during the past twenty-five years.

In a study of permanent loss of head, rainfall must be taken into consideration. A comparison must be made between the rainfall at and preceding the time each set of data was being collected. This comparison must not be restricted to the actual years covered by the readings, but must include several years prior to each period represented by the data. The average rainfall for Sanford and vicinity is 50.33 inches per year. This average is based upon the twenty-four year period from 1913 through 1936. The first set of well readings was collected between 1909 and 1911. The period for 1907 through 1911 shows an average yearly rainfall of 45.33 inches. This is 5 inches below the normal. Thus there is an accumulated deficit of 25 inches of rain for this five-year period. On the other hand, the years 1933 through 1936 had an average rainfall of 52.2 inches per year, or an average of 1.87 inches above normal for each year. The year 1937 has been slightly above normal rainfall to date. The accumulated difference between these averages is 32.42 inches, excluding the year 1937. It may be inferred, therefore, that should there be another long period of subnormal rainfall the evident loss of head would be even greater than that shown by the comparison I have made, and that this four to ten foot loss of head is a conservative estimate.

FLUCTUATION OF THE ARTESIAN HEAD

Observation of the artesian wells has shown that the head of the water is constantly fluctuating. The amount of fluctuation was found to range from less than one foot in the non-flowing area to as much as five and six feet within the flowing-well zones.

The causes for the fluctuation of the wells are rainfall, barometric pressure, and draft.

General rains over a large area serve to recharge the water supply of the artesian reservoir. The effect of this recharge, however, is not seen immediately and little or no effect is expected from local rain. The reason for an increase in head immediately after local rains lies in the fact that almost all the farmers shut off their wells, thus very shortly the pressure of the wells is materially increased.

The fluctuation in head due to differences in atmospheric pressure is not so great as that caused by shutting and opening the wells, and such changes are best observed in non-flowing wells.

THE PIEZOMETRIC SURFACE

In order to understand the condition of the underground reservoir of the county, and to determine the direction of flow of the artesian waters, two maps of the piezometric surface have been made. One represents the piezometric surface for February, 1937, a month during which nearly all the truck farms in the county are being irrigated. The second map shows the piezometric surface for July. During this month very few of the farm wells are in use, and the large celery wash houses are not operating. Probably there is less draft on the wells during July than in any other month of the year. The contour lines on both maps represent the artesian head above mean sea level.

Certain general features are characteristic of both maps. The contours rise toward their highest point in the southwest part of the county, and drop to their lowest point in the northeast. Although there are no artesian wells in the extreme northeast part of the county, I suspect that the contour will be below ten feet above sea level. This feature demonstrates that the direction of flow is from the southwest. A small amount of recharge may take place in the lake region in the southwest part of the county; but the principal recharge region is probably Orange, Lake and Polk counties. On both maps the contours swing westward at Lake Jessup. This indicates a heavy leakage zone in that lake. Another heavy leakage zone is also present along the Wekiva River. The forty-five foot contour swings almost due south as it approaches the river. Leakage is probably also taking place in Lake Harney. A permanent depression cone due to excessive draft is present between Lake Jessup and the St. Johns River east of Sanford. In this district there are a number of celery wash houses. These plants use an excessive amount of water, and as yet they have not made any very effective steps toward the conservation of water. During February the center of this cone had dropped to about 21 feet above sea level. In

July the center had risen to nearly twenty-five feet. Another small cone is shown by a 30 foot contour directly south of Sanford. This cone surrounds the wells used for the City of Sanford public supply. The wells located outside the flowing-well zone vary only slightly, and a difference is difficult to show on the piezometric maps.

On the February map, it may be seen that the contours swing back from the farming areas around Lake Jessup and Lake Monroe. Local coning can be seen south of Oviedo, and a slight coning is indicated east of Lake Monroe station. The contours do not represent a closed cone, but the space between the 20 and 25 foot contours broadens perceptibly.

On the July map the contours are higher over the flowing-well district. The local cones due to draft for irrigation have returned to normal, and extremely heavy coning shown around the wash houses is not so pronounced.

SALINITY OF THE WATERS

A large part of the waters used for irrigation in the county is already highly saline. Some wells that have been checked showed a chloride content exceeding eighteen hundred parts per million.

The belief is quite common that this high salinity is due to seepage of sea water into the rocks. This hypothesis is incorrect. All the peninsula of Florida is underlain by connate salt water, salt water contained in the rocks when they were laid down. Over most of the state, this saline water is confined to variable but relatively great depths. In areas where the fresh water head has been sufficiently reduced, however, the salt water has risen to or near to the surface of the artesian strata. As has been pointed out by Badon Ghyben of Amsterdam and Herzberg of Berlin, for every foot of fresh water head that is lost there is an upward encroachment of salt water for approximately forty feet; the exact amount of the encroachment being dependent upon the specific gravity of the salt water. This encroachment can be seen in Florida in certain counties near the coast where the loss of fresh water head has been excessive.

The condition existing in Seminole County is basically a function of the theory set forth by Ghyben and Herzberg, but the manner in which the high salinity has been developed has been much more complex than the ideal problem confronting those writers. The most highly mineralized waters in this county are coming from the Coskinolina zone of the Eocene. This zone was raised above the sea and deeply eroded before the deposition of the younger deposits. The region around Lake Jessup and along

the St. Johns River was undoubtedly a leakage zone during that period of uplift.

After the submergence of this zone and the subsequent deposition and uplift of the Ocala formation, this region was again developed as a leakage zone. Before the second submergence, the Ocala formation was almost completely eroded away in the present highly saline area, and the Coskinolina zone was exposed at the surface. After the Miocene submergence, the same conditions were repeated. This excessive leakage over long periods of time sufficiently reduced the fresh water head to allow the highly saline waters to move upward to the surface of the Coskinolina zone, and today all the artesian waters in this area are saline.

Waters from the Ocala formation are not as yet highly saline; but the excessive draft that is taking place is causing a further upward encroachment of saline waters, and an eventual increase in the highly saline area is to be expected.

CONCLUSION

This survey has shown that there has been a permanent loss of head due to excessive draft, and that a large part of the county is now drawing upon highly saline waters. Further development and excessive use of the artesian waters can be expected to reduce the present area of artesian flow and to materially increase the areas of highly saline waters. A serious curtailment of agricultural operations will undoubtedly result, unless proper precautions are taken and the use of artesian waters wisely regulated in the future.

THE EFFECT OF COLD STORAGE ON CERTAIN NATIVE AMERICAN PERENNIAL HERBS

Part I

HERMAN KURZ

Florida State College for Women

INTRODUCTION

AMONG PRACTICAL growers it is pretty generally known that the perenniating parts of many cultivated flowering herbs must be subjected to a period of cold storage in order to insure the development of normal foliage and flowers. In fact a good many

popular and semi-popular articles dealing with cold storage as a necessary antecedent for subsequent growth have been published in garden journals and in agricultural experiment station bulletins. And when it comes to low temperature relations in general there is prodigious technical literature. Harvey's ('36) "An Annotated Bibliography of the Low Temperature Relations of Plants" is a letter size volume of 240 pages. In the present paper, however, reference will be made only to important pioneer works having a direct bearing and relation to its studies. Foremost among such works is the classical paper of Coville ('19-'20) on "The Influence of Cold in Stimulating the Growth of Plants." Indeed many of the speculations and generalizations regarding the necessity of cold storage, as well as the nature of its effect, for the normal development of various cultivated species trail back to his experiments in the 'teens. He found, for example, that the buds of such American woody species as *Epigaea repens*, *Vaccinium corymbosum*, *Viburnum americanum*, *Pyrus coronaria*, *Larix Laricina* and the seeds of *Cornus canadensis* kept in the green house and deprived of winter exposure would not resume a normal growth following the usual winter period of dormancy. In sharp contrast the plants or even parts of plants that were subjected to winter chilling developed normally. This work is so well known and accessible that its details may be omitted here. Suffice it to say that Coville considers winter chilling a normal necessity for the above and other species.

Nichols ('34), too, in working with the seeds of 141 species of native American herbs and shrubs has made a significant contribution. In the main he found that the seeds of northward distribution were benefitted by exposure to winter temperature; as a matter of fact a good many of southward distribution also responded favorably to refrigeration. Nichols concludes that "refrigeration may be an ecological factor of much importance in relation to the northward distribution of plants."

Coville ('19, '20) gave a direct and significant lead 18 years ago when he stated that "the whole question of the effect of chilling on herbaceous perennials is an open field," but up to the present the writer has found no references to studies attacking the influence of freezing as an ecological or distributional factor on the perenniating parts of native American herbs.

PRELIMINARY EXPERIMENTS

Ever since the writer came to Florida he has had an irrepressible desire to grow northern "spring flowers" in his artificial

woods. This desire led to the importation in 1930 of a number of northern species like *Erythronium americanum*,¹ *Dicentra cucullaria*, *Polemonium reptans*, *Claytonia virginica*, *Dodocatheon meadia*, *Iris versicolor*, *Trillium* spp., *Adiantum pedatum*, and even *Equisetum arvense*! Although only exploratory in nature the writer feels that the behavior and leads suggested by them justify a brief description and discussion.

Equisetum arvense rhizomes set out in a local garden around September 10 proceeded to sprout and to send up typical vegetative shoots within a few weeks. However, after this initial burst of growth lasting for about two months the shoots died and no new ones ever appeared again.

Iris plants potted in common garden soil in the autumn of 1931 produced three small feebly growing shoots in the spring of 1932; by March 1933 the shoots were almost dead. The pot was now put in a mechanical refrigerator and taken out April 23, 1933, one month later. This refrigeration of one month was enough to stimulate the shoots to vigorous growth. From December 11, 1933, to February 27, 1934, the plants were refrigerated again; and still greater growth resulted. From December 1934 to February 1935 they were again refrigerated. As a result of this last refrigeration the plants formed seven shoots with the tallest leaves 16 inches high, and by May a total of 5 flowers. Because of subsequent freezing the plants, although they have not bloomed again, are healthy at this writing.

The *Polemonium* plants set in garden soil survived less than two years and the leaves that appeared proved to be progressively smaller and smaller until the plant died. In the winter of 1932 one plant in the garden was stimulated to new growth and flowers by the simple expedient of covering the dormant plant with ice for a week or so. We see here that although chilling is necessary no great amount seems imperative.

In December of 1933 ten cultures of *Erythronium americanum* containing fifteen bulbs each were placed in a refrigeration room of about 32 degrees Fahrenheit of the Middle Florida Ice Company, Tallahassee. These cultures were taken out one by one: the first one after two weeks of refrigeration; the second at the end of three weeks; the third at the end of four weeks; the fourth at the end of five weeks; the fifth at the end of six weeks; the sixth at the end of seven weeks; the seventh at the end of eight weeks;

¹All nomenclature in this paper is according to "Gray, Asa. New Manual of Botany. 7th Edition. 1908."



LEGEND

Left, stored in cooler; right, left outdoors.

Upper left, *Trillium grandiflora*; upper right, *Dicentra cucullaria*.

Middle left, *Polemonium reptans*; middle right, *Smilacina racemosa*.

Lower left, *Geranium maculatum*; lower right, *Claytonia virginica*.

the eighth at the end of nine weeks; the ninth at the end of ten weeks; and the last one at the end of eleven weeks. The first pot taken out with two weeks of chilling produced only 1 normal leaf of one and one-half inches. Because of disturbance of the cultures by rodents and possibly because certain bulbs require at least one year for thorough establishment when transplanted there were twisted and incompletely unfolded leaves in most cultures. But in general the longer the refrigeration, the more, the larger, and the more nearly normal were the leaves after the cultures were again subjected to out-of-door growing conditions.

PREPARATION AND CARE OF FOLLOW-UP CULTURES

The preliminary findings, it was felt, justified a more elaborate follow-up; accordingly, beginning with the autumn of 1933 and successive autumns propagative parts of a total of twenty-one species of native American herbs were obtained from New England nurseries and other northern sources. Each lot of the twenty-one species was evenly divided and planted in duplicate pots containing local garden loam. One member of each pair was designated for artificial chilling and the other for exposure to natural Tallahassee, Florida, winter conditions. If two pairs of a given species were run, the cultures were designated as "A" and "B"; for instance, "Claytonia virginica (A)" and "Claytonia virginica (B)". Some time in December, the date varying with the year, one half of each species was exposed from 8 to 11 weeks to the north Florida natural winter conditions on the shady, north side of a large bamboo bush; the other half was stored from 8 to 11 weeks in a vegetable cooler room of the Middle Florida Ice Plant. While the attempt was made to keep the temperature of this cooler around 40 degrees Fahrenheit it should be noted that a maximum-minimum thermometer showed a range of 34 to 58 degrees. It is to be regretted that it was not feasible to have a more complete temperature record. In February, date varying with the year, the chilled pots were withdrawn and paired with their mates on the north side and in the partial shade of bamboos. From here, with the exception of watering and cleaning out weeds, nature was left to do the rest. A condensed history or picture of the behavior of each pair of cultures follows in Table I.

TABLE I

SPECIES	Plants or Parts per pot	CONDITION OF CULTURES EXPRESSED IN LEAVES AND FLOWERS The years refer to growing seasons beginning in February.	Distribution
<i>Adiantum pedatum</i>	6 plants	Cooler: 1936—6 fronds, tallest 10" 1937—30 fronds, 400 pinnules with sporangia, tallest 16" Outdoors: 1936—11 fronds, tallest 17" 1937—20 fronds, tallest 12", no sporangia	Rich moist woods (Gray) ¹ Avery Island, Iberia Parish La., (Wherry) ²
<i>Anemone thalictroides</i>	6 plants	Cooler: 1936—15 flowers, tallest shoot 9" 1937—42 flowers, tallest shoot 8", 132 leaflets Outdoors: 1936—11 flowers, tallest shoot 8" 1937—22 flowers, tallest shoot 8", 71 leaflets	s. N. H. to Minn., Kan. (Gray) N. Fla. to Ark. (Small) ³
<i>Claytonia virginica (A)</i>	Many corms	Cooler: 1935—30 inflorescences, tallest 6", 75 healthy leaves, largest 6" 1936—20 inflorescences, tallest 7" 1937—12 inflorescences, tallest 6" Outdoors: 1935—6 inflorescences, tallest 4", 100 leaves, largest 3" 1936—dead	w. N. H. to Ga., westw. to Minn. and Kansas (Gray) n. of Coastal Plain (Small) w.-cent. Alabama (Harper) ⁴
<i>Claytonia Virginica (B)</i>	8 Corms	Cooler: 1935—5 inflorescences, longest 5", longest leaf 5" 1936—3 inflorescences, longest 5.5" 1937—dead—no corms. Outdoors: 1935—no growth 1936—no growth 1937—no corms, dead.	

<i>Dicentra cucullaria</i> (A)	30 bulbs	<p>Cooler: 1934—15 flowers, longest leaf 4" 1935—6 inflorescences, 40 leaves, longest 5" 1936—some flowers, 27 leaves, longest 8" 1937—some flowers, 53 leaves</p> <p>Outdoors: 1934—no flowers, 6 leaves, longest leaf 1" 1935—2 leaves, longest 1.5" 1936—no flowers, 1 small leaf 1937—dead, no corm.</p>	N. S. to L. Huron and Minn., s. to N. C. and Mo. (Gray) Ga. to Nebr. (Small) Tenn. Val. (Harper)
<i>Dicentra Cucullaria</i> (B)	10 bulbs	<p>Cooler: 1935—1 inflorescence, 30 leaves, tallest 6" 1936—1 inflorescence, longest leaf 9" 1937—1 inflorescence, 22 leaves, longest 8"</p> <p>Outdoors: 1935—no flowers, 19 leaves, tallest 7" 1936—no flowers, longest leaf 6.5" 1937—no flowers, 3 leaves, longest 4"</p>	
<i>Dodocatheon Meadia</i> (A)	6 crowns	<p>Cooler: 1934—6 rosettes, 5 of them robust, longest leaf 4", 2 flowering scapes 1935—5 healthy rosettes, longest leaf 7", 2 flowering scapes 1936—5 rosettes, longest leaf 7", 1 flowering scape 1937—7 rosetes, longest leaf 6", no flowers, 8 live crowns in autumn</p>	Pa. and Md. to Man. (Gray) Coastal Plain, Ga. to Texas (Small)

1. Northernmost distribution according to Gray ('08)

2. Southernmost distribution according to Wherry ('36)

3. Southernmost distribution according to Small ('33)

4. West Central Alabama and Tennessee Valley distribution according to correspondence by Dr. R. M. Harper, Plant Geographer, University of Alabama.

TABLE I—Continued

SPECIES	Plants or Parts per pot	CONDITION OF CULTURES EXPRESSED IN LEAVES AND FLOWERS The years refer to growing seasons beginning in February.	Distribution
<i>Dodocatheon Meadia</i> (B)	5 crowns	Outdoors: 1984—5 rosettes, longest leaf 8.5", 1 diseased flowering scape 1985—5 weak rosettes, longest leaf 4.5", no flowers 1986—1 rosette, longest leaf 5", no flowers 1987—dead Cooler: 1985—5 rosettes, longest leaf 5" 1986—6 rosettes, longest leaf 5", 3 flowering scapes, capsules later 1987—1 rosette, longest leaf 4", 1 flowering scape, 4 flowers, capsule Outdoors: 1985—5 rosettes essentially as those from cooler 1986—5 rosettes, longest leaf 5", 1 flowering scape, capsules 1987—2 rosettes, longest leaf 3", 1 flowering scape, 6 flower buds dried up.	.
<i>Erythronium americanum</i> (A)	12 bulbs	Cooler: 1985—9 leaves, tallest 2" 1986—18 leaves, tallest 4" 1987—18 leaves, tallest 4" Outdoors: 1985—8 leaves, tallest 2" 1986—no growth Cooler: 1986—9 leaves, longest 5" 1987—26 leaves, longest 3" Outdoors: 1986—1 leaf, 2" long 1987—no growth	N. B. to Fla. west to Ont. and Ark. (Gray) Fla. to Ark. (Small) West-central Ala. (Harper)
<i>Erythronium americanum</i> (B)	11 bulbs		

<i>Geranium maculatum</i>	5 crowns	<p>Cooler: 1984—6 flower stalks, tallest 12" 1985—no flowers, 75 leaves, tallest 8" 1986—1 flower stalk, 40 leaves, tallest 12" 1987—2 flower stalks, 74 leaves, tallest 12"</p> <p>Outdoors: 1934—no growth 1935—no flowers, 10 leaves, tallest 4" 1936—no flowers, 5 leaves, tallest 7" 1937—no flowers, 1 leaf, 2" tall</p>	centr. Me. to Man. and southw. (Gray) Ga. to Kan. (Small) west-centr. Ala. (Harper)
<i>Hepatica acutiloba (A)</i>	5 crowns	<p>Cooler: 1934—2 flowers, 75 new leaves 1935—no flower, 19 new leaves</p> <p>Outdoors: 1934—no flowers, 13 new leaves 1935—1 flower, 7 new leaves (discontinued)</p>	w. Que., southw. through w. N. H. (Gray) Ga., Mo. (Small) Tenn. Valley (Harper)
<i>Hepatica acutiloba (B)</i>	5 crowns	<p>Cooler: 1936—no flowers, 9 new leaves 1937—no flowers, 5 new leaves</p> <p>Outdoors: 1936—no flowers, 11 new leaves 1937—no flowers, 6 new leaves</p>	N. S. to Fla., Mo., and Minn., and east w. (Gray) N. W. Fla. (Harper)
<i>Hepatica triloba (A)</i>	5 crowns	<p>Cooler: 1934—11 flowers, 55 new leaves 1935—no flowers, 20 new leaves (discontinued)</p> <p>Outdoors: 1934—2 flowers, 15 leaves 1935—no flowers, no new leaves (dead)</p>	
<i>Hepatica triloba (B)</i>	5 crowns	<p>Cooler: 1936—no flowers, 23 new leaves 1937—1 flower, 53 leaves</p> <p>Outdoors: 1936—no flower, 20 leaves 1937—1 flower, 10 leaves</p>	

TABLE I--Continued

SPECIES	Plants or Parts per pot	CONDITION OF CULTURES EXPRESSED IN LEAVES AND FLOWERS The years refer to growing seasons beginning in February.	Distribution
<i>Iris versicolor</i>	6 buds or crowns	Cooler: 1934--in flower, tallest leaf 15" 1935--no flowers, 8 shoots, tallest leaf 14" 1936--no flowers, 9 shoots, tallest leaf 15" 1937--no flowers, plant healthy, 10 shoots, tallest leaf 13" Outdoors: 1934--no flowers, tallest leaf 17" 1935--no flowers, 4 shoots, tallest leaf 18" 1936--no flowers, 4 shoots, tallest leaf 3" 1937--dead	Nfd. to Man. (Gray) Ga. to Miss. (Small)
<i>Isoopyrum biternatum</i>	5 plants	Cooler: 1936--no flowers, 8 leaves, tallest 4" 1937--no flowers, 69 leaflets, tallest leaf 5" Outdoors: 1936--no flowers, 11 leaves, tallest 5" 1937--4 flowers, 99 leaflets, tallest leaf 7"	s. Ont. to Minn. and southw. (Gray) w. Fla. to Tex. (Small)
<i>Lilium canadense</i>	6 bulbs	Cooler: 1934--3 flowers, 6 stems, tallest 12" 1935--2 flowers, 9 stems, tallest 10" 1936--1 flower, 2 stems, tallest 21" 1937--1 flower 10 stems, tallest 18" Outdoors: 1934--no flowers, 6 stems, tallest 12" 1935--no flowers, 8 stems, tallest 8" 1936--no flowers, 7 stems, tallest 10" 1937--no flowers, 2 stems, tallest 3"	e. Que. to Ga., w. to Mo., Minn., and Ont. (Gray) Ga. to W. Fla. (Small) Tenn. Valley (Harper)

<i>Lilium superbum</i> (A)	2 bulbs	<p>Cooler: 1934—2 stems, one 13" high, the other 9", no flowers</p> <p>• 1935—1 stem 20" high, one abortive flower bud</p> <p>Outdoors: 1934—no growth</p> <p>1935—2 stems, one 21" high, the other 8"</p> <p>Cooler: 1936—one stem 20" tall, one abortive flower bud</p> <p>Outdoors: no growth</p>	N. B. to Minn. (Gray) Ga. to Ark. (Small) Also N. Fla. (Kurz)
<i>Lilium superbum</i> (B)	2 bulbs	<p>Cooler: 1938—3 shoots, tallest 29", total of 136 leaves, 2 flowers</p> <p>Outdoors: 1938—4 shoots, tallest 16", total of 170 leaves, no flowers</p> <p>Cooler: 1938—3 shoots, tallest 27", total of 165 leaves, no flowers</p> <p>Outdoors: 1938—4 shoots, tallest 21", total of 85 leaves, 5 flowers</p>	
<i>Lilium superbum</i> (C)	2 bulbs (large)	<p>Cooler: 1934—6 flower stalks, tallest 17", 97 flowers</p> <p>1935—vegetative growth but no flowers (accidentally destroyed)</p> <p>Outdoors: 1934—3 flower stalks, tallest 12", 23 flowers</p> <p>1935—dead</p>	N. Y. and Ont. to Nebr. and southw. (Gray) Coastal Plain, Ala. to Ark. (Small)
<i>Lilium superbum</i> (D)	2 bulbs (small)	<p>Cooler: 1934—6 flower clusters</p> <p>1935—many flowers, seeds formed</p> <p>1936—no flowers, plants not vigorous</p> <p>1937—13 flowers, plants robust, 115 leaves</p> <p>Outdoors: 1934—5 flower clusters</p> <p>1935—no flowers, plant dead</p>	w. Que. to Minn. and southw. (Gray) n. Fla. to E. Tex. (Small)
<i>Mertensia virginica</i>	6 crowns		
<i>Phlox divaricata</i> (A) (from New England)	5 plants		

TABLE I—Continued

SPECIES	Plants or Parts per pot	CONDITION OF CULTURES EXPRESSED IN LEAVES AND FLOWERS The years refer to growing seasons beginning in February.	Distribution
<i>Phlox divaricata</i> (B) (from Iowa)	one plant	Cooler: 1934—20 flower clusters, 65 flowers, several flowering shoots 1935—11 flower clusters, many flowers, about 100 leaves. Plants dead by autumn. Outdoors: 1934—on flower cluster, 8 flowers, one flowering shoot 1935—no flower cluster, about 100 leaves. Plants dead by autumn	
<i>Podophyllum peltatum</i> (A)	At least 5 buds	Cooler: 1936—two leaves, tallest 15" 1937—one flower, aborted, 5 leaves, tallest 12" Outdoors: 1936—2 leaves, tallest 12" 1937—dead	w. Que. and w. N. Eng. to Minn. and southw. (Gray) Fla. to Tex. (Small) n. w. Fla. (Harper)
<i>Podophyllum peltatum</i> (B)	At least 5 buds	Cooler: 1936—4 leaves, tallest 15" 1937—5 leaves, tallest 15" Outdoors: 1936—3 leaves, tallest 10" 1937—dead	
<i>Polemonium reptans</i>	3 crowns	Cooler: 1934—40 opened flowers, large leaves 1935—5 flowers, plant smaller 1936—2 flowers, 24 leaves 1937—no flowers, 12 leaves Outdoors: 1934—no flowers, prostrate dwarf leaves 1935—plant dead	N. Y. to Minn. and southw. (Gray) Ga. to Miss. (Small) w. centr. Ala. (Harper)
<i>Sanguinaria canadensis</i>	6 rhizomes	Cooler: 1936—1 flower, 9 leaves, tallest 8" 1937—2 flowers, capsules, 10 leaves, tallest 7" Outdoors: 1936—no flowers, 1 leaf, 5" tall 1937—dead	Common (Gray) N. S. and Man. to Ark. and n. Fla. (Small)

<i>Smilacina racemosa</i>	rhizomes with at least 6 buds	Cooler: 1934—2 flower clusters, 4 shoots, tallest 14" 1935—2 flower clusters, 15 fruits, 6 shoots, tallest 10" 1936—3 flower clusters, fruits, 8 shoots, tallest 19" 1937—6 flower clusters, fruits, 9 shoots, tallest 16" Outdoors: 1934—1 aborted flower cluster, 4 shoots, tallest 5" 1935—1 flower cluster, 1 fruit, 5 shoots, tallest 8" 1936—1 flower cluster, no fruit, 10 shoots, tallest 12" 1937—no flowers, 9 shoots, tallest 9"	Ga. to Tex., Calif., B. C., Ont. and N. S. (Gray) w. centr. Ala. (Harper)
<i>Symplocarpus foetidus (A)</i>	5 crowns	Cooler: 1936—4 shoots, 15 leaves, tallest 14" 1937—3 shoots, 18 leaves, tallest 10" Outdoors: 1936—1 shoot, 6 leaves, tallest 11" 1937—1 bud, no growth Cooler: 1936—1 shoot, 6 leaves, tallest 10" 1937—1 shoot, 8 leaves, tallest 4" Outdoors: 1936—1 shoot, 2 leaves, tallest 8" 1937—1 bud, no growth	N. S. to N. C., w. to Ont., Minn. and Ia. (Gray) Ga. (or Fla.) (Small)
<i>Symplocarpus foetidus (B)</i>	2 crowns	Cooler: 1934—2 flowers, aborted, 2 shoots 1935—8 shoots, tallest 5" 1936—1 flower, capsule, 3 shoots, tallest 9" 1937—6 shoots, tallest 8" 1 flower Outdoors: 1934—no growth 1935—4 shoots, tallest 3" 1936—1 flower, capsule, 2 shoots, tallest 8" 1937—no growth	w. Que. and w. Vt. to Minn. (Gray) Coastal Plain, N. C. to Ark. (Small) Tenn. Valley (Harper)
<i>Trillium grandiflorum</i>	6 root stocks		

PRESENTATION AND COMMENTS ON THE DATA

In studying the table it appears reasonable to conclude that since they were run in duplicates *Claytonia virginica*, *Dicentra cucullaria*, *Erythronium americanum*, *Hepatica triloba*, *Iris versicolor*, *Phlox divaricata*, *Podophyllum peltatum*, *Polemonium reptans*, and *Symplocarpus foetidus*, all require a period of chilling.

The data also suggest that *Geranium maculatum*, *Lilium canadense*, *Mertensia virginica*, *Sanguinaria canadensis*, *Smilacina racemosa*, and *Trillium grandiflora* also demand a period of low temperature. Had these been run in duplicates, we could be more confident.

The responses of *Anemonella thalictroides*, *Adiantum pedatum*, *Dodocatheon Meadia*, *Hepatica acutiloba*, *Isopyrum biter-niatum*, and *Lilium superbum*, were in terms of rate of growth rather than ultimate growth. In all cases the chilled culture grew and matured earlier than the outdoor mates. In the end, however, there was no significant difference.

It should be noted in passing that getting away to a faster start than their unchilled duplicates was characteristic for all cultures that were chilled.

Of general significance is the fact that chilling temperatures seldom as low as 32 degrees Fahrenheit could, when applied for a sustained period, promote growth in plants accustomed to the much lower temperature of the northern winter woods.

GRADUAL DECLINE OF UNFROZEN CULTURES

In observing Table I the reader will notice that in most cases the unfrozen cultures produced at least some growth the first run and that in some species final disintegration of the unfrozen specimens did not take place until the third year. In this connection see the photograph *Polemonium reptans*. A study of the graphs will reveal similar concrete examples. It appears from this behavior that the chilling of a year suffices to tide certain species over at least one unfavorably warm period. Attention is directed to a statement in the "Preliminary Experiments" section of this paper where it is shown how waning *Iris* and *Polemonium* plants were stimulated to renewed growth and vigor by emergency low temperature treatment.

Another thing to be noted in Table I is the fact that, in a number of cases, even the frozen cultures disintegrated after two or more years. This is probably due to the inability of these wild species to thrive indefinitely in such artificial habitats as potted soils. The fact that the frozen ones still do better than the unfrozen ones is, therefore, still meaningful.

GENERAL DISCUSSION

According to the field observations of R. M. Harper (by letter) *Polemonium reptans*, *Geranium maculatum*, *Claytonia virginica*, *Smilacina racemosa*, and *Erythronium americanum*, reach just about their southern limits in the Tuscaloosa latitude. Those same species, it will be noted, did not resume normal growth upon exposure to the winter conditions of Tallahassee, 160 miles nearer the moderating influence of the Gulf. It becomes of interest, therefore, what the temperature differences are between the two localities. The tabulated data summarize what appear to be some of the significant differences. (Taken from U. S. weather publications.)

TABLE II. TEMPERATURE RECORDS

Average annual number of days with minimum temperature at or below freezing.	Tallahassee, Fla. Region 5-15 (10)	Tuscaloosa, Ala. Region 30-60 (40)	
Average annual number of days with temperature continuously below freezing.	none	1- 5	
Average monthly temperature for:	Tallahassee, Fla. (over pd. of 32 yrs.)	Tuscaloosa, Ala. (over pd. of 43 yrs.)	Difference
December	53.6	45.8	7.5
January	53.6	44.7	5.9
February	55.0	46.5	8.5
Average minimum temperature for:			
December	41.3	31.9	9.4
January	43.8	33.9	9.9
February	44.8	35.1	9.7

Which of these differences in temperature conditions or relations are the most important it is not possible to state. However, it should be pointed out that Coville ('29) found that temperatures as high as 35 to 40 Fahrenheit for a period of two months were low enough to bring about germination of *Cornus canadensis* seeds.

Coville expressed the opinion eighteen years ago that chilling "appears to be a critical factor in determining how far such plants (trees and shrubs) may go into the extension of their geographic distribution toward the tropics." Nichols, already quoted, points out that winter refrigeration of seeds of native plants may be an important factor in determining plant distribution. The responses of the perennial herbs discussed in the present paper lead to a similar conclusion. The behavior of the writer's perennial herbs seems to warrant a similar reasoning and to lead to the following assertions: To speak only of "frost resistance," "hardiness," and "low temperature endurance" gives

a one-sided picture of the temperature relations in the distribution of native plants. Many species are certainly restricted in their northward extension because of low temperature. Statements to that effect are surely true. But it is equally true that a number of, if not many, species are barred from extreme southern distribution, because they cannot forego such a periodic spell of low temperature. Coville has also pointed out "that chilling of dormant trees and shrubs of temperate climates as a prerequisite to their resumption of normal growth in spring ought to be recognized in books on plant physiology as one of the normal processes in plant life." The writer is fully in accord with that observation. Unfortunately Coville's lament has to this day brought little response. It does seem that the contribution made on low temperature requirements fully warrant, if not demand, at least some consideration in modern texts of general botany, ecology, and plant geography, if for no other reason than to stimulate more research in this highly interesting field.

An examination of the distributional column will disclose the fact that the manuals credit Florida with *Symplocarpus foetidus* and *Erythronium americanum*. Theoretically, at least, *Symplocarpus* and *Erythronium* could likewise be represented in Florida by physiological or geographical species. It is a curious fact that up to the present, Dr. R. M. Harper (one who has explored Florida and the whole Southeast, for that matter), and the writer have never seen these species in Florida. Quite naturally the writer wondered if refrigeration experiments would possibly help to establish the fact that these species could not grow in Florida because of freezing requirements. However, *Sanguinaria*, *Podophyllum*, and *Phlox divaricata* may be represented by physiological species that do not require chilling; no corroboration, however, is produced from the reactions of the latter three species.

Physiological or Ecological Species

Anemonella thalictroides, *Isopyrum biternatum*, and *Lilium superbum* are both found locally in north Florida. So the fact that the frozen and unfrozen cultures from New England showed no significantly total amount of growth at the end of the growing season even though they started and bloomed appreciably earlier was not surprising unless one noticed that the *Sanguinaria canadensis*, *Phlox divaricata*,¹ and *Podophyllum peltatum* obtained from the North but which are also local did definitely require or benefit from freezing. The reactions of the latter three species suggest a differentiation of physiological species; the northern

¹According to Wherry ('30) the Iowa specimen which was collected in Benton County is probably *Phlox divaricata laphami*; this variety extends to the northwestern part of Florida. The New England specimen according to the same authority would probably be *Phlox divaricata canadensis*. Both varieties it will be observed benefited by chilling.

forms requiring a chilling period and the southern forms not. But the writer is not quite ready to conclude. He awaits more data. This fact presents a number of questions: Did the northern forms by long residence in a rigorous climate come to require a chilling period as Coville ('19) suggests in connection with his work? Did the southern forms because of a long sojourn in a milder climate lose this freezing prerequisite? And still other questions arise. To all these the writer has at present no definite reply.

AWAITING SOLUTION

The following are some questions that still await answers: (1) What other perennial herbs require refrigeration? (2) Are there really any or more geographical or physiological species? (3) Is the length or intensity of the freezing period in any species directly related to or proportional to the northward or southward distribution of the species? (4) That is, will Minnesota representatives of a species require more freezing (lower or longer) than Tennessee individuals? (5) Will the latter require more chilling than the Florida forms? (6) Will northern species established in Florida benefit from freezing? (7) How does the effect of a long period of freezing (a long continuous dose) compare with shorter, more frequent periods of chilling (frequent, short doses)? (8) What will happen if the cooled culture of one year is separated into two halved cultures, and half designated for artificial cooling and the other half for outdoor Tallahassee temperatures? (9) Will earlier (August and September) chilling induce earlier growth and response? (10) What would be the effect of a period of consistently freezing or even lower temperature on those that responded to chilling as well as those which responded very little? The writer has experiments in progress which should shed some light on most of these questions.

SUMMARY

1. The perenniating parts of twenty-one American native herbs were chilled at temperatures ranging most of the time around 40 degrees Fahrenheit for periods of eight to eleven weeks for four consecutive seasons. Twenty potted duplicates were at the same time subjected to winter exposure of the Tallahassee, Florida, climate. Nine of these gave definite evidence that a period of refrigeration is a necessary and beneficial antecedent to their normal growth and development.

2. *Sanguinaria canadensis*, *Phlox divaricata*, and *Podophyllum peltatum* secured from New England required a preliminary chilling period in order to resume normal growth after dormancy, despite the fact that the species are also native in northern Flor-

ida. This behavior suggests a development of physiological or geographical species within the species. On the other hand, *Anemonella thalictroides*, *Isopyrum biternatum*, and *Lilium superbum* in the same category as to northern and southern distribution responded indifferently and inconsistently to artificial chilling.

3. It is concluded that, while the inability of certain species to endure freezing temperature may restrict their northward extension, there are other species whose southward extension is restricted, because they require a chilling period before normal growth will follow dormancy.

4. Students of plant distribution and texts dealing with ecological or distributional relations of plants should give attention to low temperature requirement as well as to low temperature endurance.

ACKNOWLEDGMENTS

The writer is greatly indebted to the Middle Florida Ice Company, Tallahassee, for donating their refrigeration service. To H. H. Hume, Assistant Director of Research at the Florida Experiment station the author is indebted for cooperation in securing references.

LITERATURE CITED

- COVILLE, F. V. The Effect of Cold in Stimulating the Growth of Plants. *Jour. Agr. Res.* 20: 151-160. 1920.
- COVILLE, F. V. The Influence of Cold in Stimulating the Growth of Plants. *Ann. Report Smith. Inst.*, 281-291. 1919.
- GRAY, ASA. *New Manual of Botany*. Seventh Edition. 1908.
- HARVEY, R. B. *An Annotated Bibliography of the Low Temperature Relations of Plants*. University of Minnesota. 1-240. 1936.
- KINCER, J. B. Temperature, Sunshine and Win. U. S. Dept. Agr. *Atlas of American Agriculture*. Advance Sheet No. 7. 1-34. 1928.
- NICHOLS, G. E. The Influence of Exposure to Winter Temperatures Upon Seed Germination in Various Native American Plants. *Ecology* 15:364-373.
- SMALL, J. K. *Manual of the Southeastern Flora*. 1-1554. 3rd. Edition. 1933.
- WHERRY, E. T. The Eastern Short-style Phloxes. *Bartonia* No. 12. 25-53. 1930.
- WHERRY, E. T. Fern Field Notes, 1936. *Am. Fern Journal* 26: No. 4. 127-131. 1936.

CHECK LIST OF NATIVE AND NATURALIZED TREES IN FLORIDA

LILLIAN E. ARNOLD

University of Florida

BEFORE LISTING the trees of Florida, it becomes necessary to define a "tree." The line of demarcation between a "tree" and a "shrub" is, after all, an arbitrary matter. There is no better rule for separating the two than that contained in the discussion of

their similarities and differences by Sudworth, who states, "Difference of opinion regarding this question has increased or decreased the number of recorded aborescent species. Judgment as to when a plant is to be called a tree and when a shrub appears to be based chiefly on the size, height and diameter attained. The general rule in defining a tree includes woody plants having one well-defined stem and a more or less definitely formed crown, and attaining a height of at least eight feet and a diameter of not less than two inches. Most truly arborescent plants produce a single erect or ascending trunk. Some species of trees, however, have the habit of producing several trunks from the same root. Examples of this type of growth are to be found among the willows, some of which, on account of their large size, obviously are properly classed as trees." It should be borne in mind, also, that there are many plants usually shrubby of nature, that occasionally become trees in some part of their range, even though it is outside our State. All such plants have been included in this compilation. Further and more technically, woody plants may be said to differ from herbaceous in being (1) perennial and possessing (2) vascular or specialized conducting tissue, (3) a trunk, (4) lignification and (5) secondary thickening. These must be taken all together, as no one condition is true solely of a tree. However, these conditions do not need to be discussed in a publication of a popular nature.

With these differences in mind, 313 species are here included in the check list of native trees, together with 53 trees known to have become naturalized in the state. The latter list is incomplete.

ORIGIN OF THE FLORA OF THE STATE

Three elements of flora meet in Florida. To account for their presence it is of interest to set forth briefly the geological history of the region as it is now understood. Schuchert has shown that as late as Upper Eocene times the whole of what is now the State of Florida was submerged. During the Oligocene period an island emerged which occupied a territory that included all of what is now central Florida and extended beyond the present coast lines on the east and west. Warm ocean currents flowed north of this island, the flora of which must have been wholly tropical and similar to that of the West Indies today. During the Miocene period, the eastern and western coast of this island sank slowly, while the northern half of the peninsular was elevated at the same time, thus connecting the island with the mainland. During Pleistocene times, the southern quarter of the peninsula and the keys emerged. During these ages successive glacial drifts sent periods of cold climate southward. Many plants commonly regarded as peculiar to more northerly sections of the United States

were carried by flood waters into what is now known as Florida and, having become adjusted and established, became an integral part of the present flora.

Therefore it may be concluded that certain plants native to the central portion of the peninsula are the original settlers among Florida's flora. Those more tropical plants that could not withstand the advent of a colder climate were destroyed in the northern parts of the state and they remain today only in the southern portions of the peninsula where they constitute a tropical element of the flora related to and in some instances identical with the Antillean. In addition certain plants of the West Indian flora have become established in this region through the agencies of birds, wind and water. Glacial periods have been a factor in the establishment of a northern floral element in the northwestern parts of the state. The margins of the area in which these groups of plants are found are not clearly defined, but rather they merge into one another.

FACTORS INFLUENCING THE FLORA

CLIMATE

The climate of Florida is insular and the immediate and chief factors of climatic control are (a) latitude, (b) elevation above sea-level and (c) proximity to large bodies of water, and (d) the presence of the Gulf Stream along the eastern coast.

Latitude: The State of Florida lies between latitudes $24^{\circ} 32'$ and 31° N. and longitudes $79^{\circ} 48'$ and $87^{\circ} 38'$ W. It is over 427 miles in length along the 82° meridian and 382 miles wide along the $30^{\circ} 10'$ parallel. This geographical location and extension, favors long summers and offers generous scope for a diversified flora. According to Merriam, the greater part of the State lies in the Lower Austral Life Zone, with the most southern part in the Tropical Belt.

Elevation: Since only small areas here and there in the state are above 300 feet elevation, variations in altitude have little effect on the general distribution of plants. However, topography, different soil types and availability of water produce different and distinct ecological conditions, which greatly influence the character of local flora. Plants of the well-drained central ridge section differ from those growing along the larger streams and the dune flora of the coast portrays the effects of another set of ecological environments.

Since Florida is a region of comparatively slight relief, the source of underground water is mainly the local rainfall, which accumulates in various small basins of the subsoil. There are a number of springs from which water pours in enormous volumes, giving support to a typical flora on the banks of the streams they form, as well as within the streams themselves. Again, there is

a vast swampy limestone underlain plain of nearly 5000 square miles, known as the Everglades, which slopes gently southward. Out of this area arise islands, commonly known as keys, clothed with a dense growth of hardwoods among which various representatives of tropical trees and other plants are found.

Proximity to Water: The peninsula lies between the Gulf of Mexico and the Atlantic Ocean. The presence of these large bodies of water, as well as the presence of thousands of lakes, has a beneficent effect upon the vegetation of the State, in that the evaporation from them prevents the occurrence of frost in some instances or minimizes the effects of it in a measure in others. The effect of the inland bodies of water, however, is mainly local.

TEMPERATURE

A difference of 4° in latitude—as from Jacksonville to Miami—gives about a six-degree change in temperature. The average seasonal temperatures for the State are: Summer, 80.8; autumn, 72.5; winter, 59.5; and spring, 70.4. From data collected from 1892 to 1927, it has been established that the mean temperature for the entire State has been 70.9° F.

PRECIPITATION

The Gulf of Mexico and the Atlantic Ocean are the chief sources of supply of Florida's precipitation. The State is so situated geographically as to justify the expectation of generous rainfall, over half of which falls in the daytime in the four warmest months. All districts of the State have received annual amounts in excess of 80 inches, the marked excesses being more frequent in coastal districts than in the interior. The data collected from 1892 to 1927 give 52.29 inches as the average annual rainfall for that period.

It is, therefore, noted that the geographical location of the State of Florida is the controlling factor of a set of climatological conditions that are all conducive to an abundant flora in which large numbers of trees are represented.

The following check list contains the botanical and common names and family of 313 species of trees native to Florida, of which 15 are cone-bearing and 11 are palm or palm-like. In compiling this list, the synonymy and range records reviewed may be found under the heading of references. The nomenclature follows that used by J. K. Small in Manual of Southeastern Flora.

The check list of the naturalized trees of the State contains the same data as the preceding one, but our information on the number of naturalized trees is still incomplete pending a more

thorough survey of the State. The nomenclature follows that used by L. H. Bailey in Standard Cyclopaedia of Horticulture.

REFERENCES

- 1 Bailey, L. H. Standard Cyclopaedia of Horticulture. 3639 pp. MacMillan. New York. 1928.
- 2 Brown, H. P. Trees of New York State Native and Naturalized. N. Y. State College of Forestry (Tech. Pub. 15) 21 (No. 5) : 11-406. 1921.
- 3 Coker, W. C. and H. L. Totten. Trees of the Southeastern States. 382 pp. Univ. of N. C. Press. Chapel Hill. 1934.
- 4 Curtis, A. H. Florida: A Pamphlet Descriptive of its History, Topography, Climate, Soil. Resources and Natural Advantages, in General and by Counties. Prepared in the Interest of Immigration by the Department of Agriculture, B. E. McLin, Commissioner: 264-267. 1904.
- 5 Gifford, John C.
- 6 Hough, Romeyn G. American Woods. Author. Lowville, N. Y. 1910. 3rd ed.
- 7 Mattoon, W. R. Common Forest Trees of Florida—How to Know Them. 98 pp. Florida Forestry Assoc. Jacksonville. Rev. 1930.
- 8 ———. Forest Trees and Forest Regions of the United States. U. S. Dept. Agr. Misc. Publ. 217; 1-54. 1936.
- 9 Merriam, C. Hart. Life Zones and Crop Zones in the United States. 79 pp. 1898.
- 10 Mitchell, A. J. and M. R. Ensign. The Climate of Florida. Fla. Agr. Exp. Sta. Bul. 200: 95-299. 1928.
- 11 Mowry, Harold. Ornamental Trees. Fla. Agr. Exp. Sta. Bul. 261: 5-134. 1933.
- 12 Sargent, C. P. Silva of North America. Houghton, Mifflin & Co., Boston. 1895.
- 13 ———. Manual of the Trees of North America. 910 pp. Houghton, Mifflin and Co., Boston. 1922.
- 14 Schuchert, Charles. Historical Geology of the Antillean-Caribbean Region. 768 pp. John Wiley & Sons. New York. 1935.
- 15 Small, J. K. Florida Trees. 107 pp. Author. New York. 1913.
- 16 ———. Manual of the Southeastern Flora. 1554 pp. Author. New York. 1933.
- 17 Sudworth, George B. Check List of the Forest Trees of the United States. U. S. Dept. Agr. Misc. Circ. 92: 1-295. 1927.

CHECK LIST OF NATIVE TREES OF FLORIDA

<i>Botanical Name</i>	<i>Common Name</i>
PINACEAE	
<i>Pinus taeda</i> L.	loblolly pine
<i>Pinus serotina</i> Michx.	pond pine
<i>Pinus clausa</i> (Engelm.) Vasey	sand pine
<i>Pinus echinata</i> Miller	short leaf pine
<i>Pinus glabra</i> Walt.	spruce pine
<i>Pinus australis</i> Michx. f. (<i>P. palustris</i> Mill.)	long-leaf pine
<i>Pinus caribaea</i> Morelet	Caribbean pine
<i>Pinus palustris</i> Mill. (<i>P. Elliottii</i> Engelm.)	swamp-pine
JUNIPERACEAE	
<i>Taxodium distichum</i> (L.) L. C. Richard	southern cypress
<i>Taxodium ascendens</i> Brongniart	pond cypress
<i>Chamaecyparis thyoides</i> (L.) B. S. P.	white cedar
<i>Sabina silicicola</i> Small (<i>S. barbadensis</i> (L.) Small)	southern red cedar

<i>Botanical Name</i>	<i>Common Name</i>
TAXACEAE	
<i>Taxodium taxifolium</i> (Arn.) Greene	stinking cedar
<i>Taxus floridana</i> Nutt.	Florida yew
ARECACEAE	
<i>Pseudophoenix vinifera</i> (Mart.) Becc. (<i>P. Sargentii</i> H. Wendl.)	Sargent's palm
<i>Roystonea regia</i> (H. B. K.) O. F. Cook	royal palm
<i>Sabal Palmetto</i> (Walt.) Todd.	cabbage palm
<i>Sabal Jamesiana</i> Small	
<i>Thrinax parviflora</i> Sw. (<i>T. floridana</i> Sarg.)	Florida thatch-palm
<i>Thrinax microcarpa</i> Sarg.	brittle-thatch
<i>Coccothrinax argentea</i> (Lodd.) Sarg. (<i>C. jucunda</i> Sarg.)	silver palm
<i>Serenoa repens</i> (Bartr.) Small. (<i>S. serrulata</i> (Michx.) Hook.)	saw-palmetto
<i>Paurotis Wrightii</i> (Griseb.) Britton. (<i>Serenoa arborescens</i> Sarg.)	saw-cabbage-palm
DRACAENACEAE	
<i>Yucca gloriosa</i> L.	Spanish bayonet
<i>Yucca aloifolia</i> L.	Spanish dagger
JUGLANDACEAE	
<i>Wallia nigra</i> (L.) Alef. (<i>Juglans nigra</i> L.)	black walnut
<i>Hicoria aquatica</i> (Michx. f.) Britt.	water-hickory
<i>Hicoria cordiformis</i> (Wang.) Britton	swamp-hickory
<i>Hicoria alba</i> (L.) Britt.	white mocker-nut
<i>Hicoria ovata</i> (Mill.) Britt.	shag-bark hickory
<i>Hicoria austrina</i> Small	
<i>Hicoria pallida</i> Ashe	pale hickory
<i>Hicoria floridana</i> (Sarg.) Small	scrub-hickory
<i>Hicoria glabra</i> (Mill.) Britton	pig-nut
LEITNERIACEAE	
<i>Leitneria floridana</i> Chapm.	corkwood
MYRICACEAE	
<i>Cerothamnus ceriferus</i> (L.) Small. (<i>Morella</i> <i>cerifera</i> (L.) Small)	wax-myrtle
<i>Cerothamnus inodorus</i> (Bart.) Small. (<i>Morella</i> <i>inodora</i> (Bartr.) Small)	odorless wax-myrtle
SALICACEAE	
<i>Populus balsamifera</i> L. (<i>P. deltoides</i> Marsh.)	cotton wood
<i>Populus heterophylla</i> L.	swamp-cottonwood
<i>Salix nigra</i> Marsh	black-willow
<i>Salix marginata</i> Wimm.	gulf-willow
<i>Salix amphiba</i> Small	
<i>Salix longipes</i> Anders	black willow
<i>Salix Chapmanii</i> Small	
CORYLACEAE	
<i>Carpinus caroliniana</i> Walt.	hornbeam
<i>Ostrya virginiana</i> (Mill.) Willd	hop-hornbeam
BETULACEAE	
<i>Betula nigra</i> L.	river-birch
<i>Alnus rugosa</i> (DuRoi) Spreng.	smooth alder
FAGACEAE	
<i>Fagus grandifolia</i> Ehrh. (<i>F. Americana</i> Sweet)	beech
<i>Castanea pumila</i> (L.) Mill.	chinquapin

<i>Botanical Name</i>	<i>Common Name</i>
<i>Castanea Ashei</i> Sudw.	chinquapin
<i>Castanea floridana</i> (Sarg.) Ashe	chinquapin
<i>Quercus alba</i> L.	white-oak
<i>Quercus stellata</i> Wang. (<i>Q. minor</i> (Marsh.) Sarg.)	post-oak
<i>Quercus Margaretta</i> Ashe	small post-oak
<i>Quercus lyrata</i> Walt.	overcup-oak
<i>Quercus Prinus</i> L. (<i>Q. Michauxii</i> Nutt.)	cow-oak
<i>Quercus Muhlenbergii</i> Engelm. (<i>Q. acuminata</i> (Michx.) Honda)	chinquapin-oak
<i>Quercus austrina</i> Small	bastard white oak
<i>Quercus geminata</i> Small	twin live-oak
<i>Quercus virginiana</i> Mill.	live-oak
<i>Quercus Chapmanii</i> Sarg.	Chapman's-oak
<i>Quercus Rolfsii</i> Small	Rolfs'-oak
<i>Quercus myrtifolia</i> Willd.	myrtle-oak
<i>Quercus nigra</i> L. (<i>Q. aquatica</i> Walt.)	water-oak
<i>Quercus laurifolia</i> Michx.	laurel-oak
<i>Quercus Phellos</i> L.	willow-oak
<i>Quercus obtusa</i> (Willd.) Pursh. (<i>Q. hybrida</i> (Michx.) Small)	blue jack-oak
<i>Quercus cinerea</i> Michx.	
<i>Quercus maxima</i> (Marsh.) Ashe. (<i>Q. rubra</i> Duroi)	red-oak
<i>Quercus Shumardii</i> Buckl.	leopard-oak
<i>Quercus laevis</i> Walt. (<i>Q. Catesbaei</i> Michx.)	turkey-oak
<i>Quercus Marylandica</i> Muench.	black-jack
<i>Quercus arkansana</i> Sarg.	
<i>Quercus velutina</i> Lam.	black-oak
<i>Quercus rubra</i> L.	red-oak
<i>Quercus Pagoda</i> Raf. (<i>Q. pagodaefolia</i> (Ell.) Ashe)	spanish-oak
ARTOCARPACEAE	
<i>Morus rubra</i> L.	red-mulberry
<i>Ficus aurea</i> Nutt.	strangler fig
<i>Ficus brevifolia</i> Nutt. (<i>F. populnea</i> Willd.)	wild fig
ULMACEAE	
<i>Ulmus alata</i> Michx.	winged elm
<i>Ulmus floridana</i> Chapm.	Florida elm
<i>Ulmus americana</i> L.	common elm
<i>Ulmus fulva</i> Michx.	slippery elm
<i>Planera aquatica</i> (Walt.) J. F. Gmel.	water-elm
<i>Celtis georgiana</i> Small	georgia-hackberry
<i>Celtis mississippiensis</i> Bosc.	sugarberry
<i>Celtis smallii</i> Beadle	Small's hackberry
<i>Trema floridana</i> Britton	Florida trema
<i>Trema Lamacrkiana</i> (R. & S.) Blume	West Indian trema
POLYGONACEAE	
<i>Coccolobis uvifera</i> (L.) Jacq.	sea-grape
<i>Coccolobis laurifolia</i> Jacq.	pigeon plum
PISONIACEAE	
<i>Pisonia rotundata</i> Griseb.	pisonia
<i>Torrubia longifolia</i> (Heimerl.) Britton	
(<i>Pisonia obtusata</i> (Chapm. Fl.)	blolly
<i>Torrubia Bracei</i> Britton	blolly
<i>Torrubia globosa</i> Small	

<i>Botanical Name</i>	<i>Common Name</i>
ANNONACEAE	
<i>Asimina triloba</i> (L.) Dunal	pawpaw
<i>Annona glabra</i> L.	custard-apple
MAGNOLIACEAE	
<i>Magnolia grandiflora</i> L. (<i>M. foetida</i> (L.) Sarg.)	magnolia
<i>Magnolia virginiana</i> L.	sweet-bay
<i>Magnolia pyramidata</i> Pursh	mountain magnolia
<i>Magnolia macrophylla</i> Michx.	great-leaf magnolia
<i>Magnolia Ashei</i> Weatherby	bushy magnolia
<i>Illicium floridana</i> Ellis	Florida anise
<i>Liriodendron Tulipifera</i> L.	tulip-tree
CAPPARIDACEAE	
<i>Capparis flexuosa</i> L. (<i>C. cynophallophora</i> L. 1759)	bay-leaved caper-tree
<i>Capparis cynophallophora</i> L. (<i>C. jamaicensis</i> Jacq.)	Jamaica caper-tree
HAMAMELIDACEAE	
<i>Hamamelis virginiana</i> L.	witch-hazel
ALTINGACEAE	
<i>Liquidambar Styraciflua</i> L.	sweet-gum
PLATANACEAE	
<i>Platanus occidentalis</i> L.	sycamore
MALACEAE	
<i>Malus angustifolia</i> (Ait.) Michx.	crab-apple
<i>Malus bracteata</i> Rehder	crab-apple
<i>Amelanchier canadensis</i> (L.) Medic.	serviceberry
<i>Crataegus Crus-galli</i> L.	
<i>Crataegus aestivalis</i> (Walt.) T. & G.	may-haw
<i>Crataegus maloides</i> Sarg.	
<i>Crataegus luculenta</i> Sarg.	shining haw
<i>Crataegus viridis</i> L.	
<i>Crataegus flava</i> Ait.	summer-haw
<i>Crataegus Michauxii</i> Pers.	
<i>Crataegus floridana</i> Sarg.	Florida haw
<i>Crataegus spathulata</i> Michx.	
<i>Crataegus Marshallii</i> Eggleston	
(<i>C. apiifolia</i> Michx.)	parsley-haw
<i>Crataegus uniflora</i> Muench.	single-flowered haw
<i>Crataegus lacrimata</i> Small	
AMYGDALACEAE	
<i>Chrysobalanus Icaco</i> L.	cocoa-plum
<i>Chrysobalanus interior</i> Small	
(<i>C. pellocarpus</i> . (FL. SE. U.S. not Mey.)	Everglade cocoa-plum
<i>Prunus americana</i> Marsh.	wild-plum
<i>Prunus umbellata</i> Ell.	sloe
<i>Prunus angustifolia</i> Marsh.	chickasaw plum
<i>Padus virginiana</i> (L.) Mill.	
(<i>P. serotina</i> (Ehrh.) Agardh.)	wild black-cherry
<i>Padus Cuthbertii</i> Small	
<i>Laurocerasus myrtifolia</i> (L.) Britton	
(<i>L. sphaerocarpa</i> (Sw.) Roem.)	West-Indian cherry
<i>Laurocerasus caroliniana</i> (Mill.) Roem.	cherry laurel

<i>Botanical Name</i>	<i>Common Name</i>
MIMOSACEAE	
<i>Pithecolobium Unguis-Cati</i> (L.) Benth.	cat's-claw
<i>Pithecolobium guadelupense</i> Chapm.	black-bead
<i>Lysiloma bahamensis</i> Benth. (L. latisiliqua Chapm.)	wild tamarind
<i>Vachellia Farnesiana</i> (L) Wight & Arn.	opopanax
<i>Leucaena glauca</i> (L.) Benth.	lead-tree
CASSIACEAE	
<i>Cercis canadensis</i> L.	red-bud
<i>Gleditsia aquatica</i> Marsh.	water-locust
<i>Gleditsia triacanthos</i> L.	honey-locust
FABACEAE	
<i>Ichthyomethia piscipula</i> (L.) A.S. Hitch.	Jamaica-dogwood
<i>Andira jamaicensis</i> (W. Wright) Urban	
<i>Erythrina arborea</i> (Chapm.) Small	red cardinal
ZYGOPHYLLACEAE	
<i>Guaiacum sanctum</i> L.	lignum-vitae
MALPIGHIACEAE	
<i>Brysonima cuneata</i> (Turcz.) P. Wilson	
(<i>B. lucida</i> (Sw.) DC)	locust-berry
RUTACEAE	
<i>Zanthoxylum Fagara</i> (L.) Sarg. (<i>Z. Pterota</i> H.B.K.)	wild-lime
<i>Zanthoxylum flavum</i> Vahl. (<i>Z. caribaeum</i> Lam.)	yellow-wood
<i>Zanthoxylum Clava-Herculis</i> L.	toothache-tree
<i>Zanthoxylum coriaceum</i> Rich.	Hercule's-club
<i>Ptelea trifoliata</i> L.	hop-tree
<i>Amyris elemifera</i> L.	torch-wood
<i>Amyris balsamifera</i> L.	balsam-torchwood
SURIANACEAE	
<i>Suriana maritima</i> L.	bay-cedar
SIMAROUBACEAE	
<i>Simarouba glauca</i> DC	paradise-tree
<i>Picramnia pentandra</i> Sw.	bitter-bush
<i>Alvaradoa amorphoides</i> Liebm.	alvaradoa
BURSERACEAE	
<i>Elaphrium Simaruba</i> (L.) Rose. (<i>Bursera</i> <i>Simaruba</i> L.)	gumbo-limbo
MELIACEAE	
<i>Swietenia Mahagoni</i> Jacq.	mahogany
EUPHORBIACEAE	
<i>Savia bahamensis</i> Britton	maiden-bush
<i>Drypetes lateriflora</i> (Sw.) Krug. & Urban.	guiana-plum
<i>Drypetes diversifolia</i> Krug. & Urban	
(<i>D. keyensis</i> Krug & Urban)	whitewood
<i>Gymnanthes lucida</i> Sw.	crab-wood
<i>Hippomane Mancinella</i> L.	manchineel
SPONDIACEAE	
<i>Metopium toxiferum</i> (L.) Krug. & Urban.	
(<i>M. Metopium</i> (L.) Small)	poisonwood
<i>Toxicodendron Vernix</i> (L.) Kuntze.	
(<i>Rhus vernix</i> L.)	thunderwood

<i>Botanical Name</i>	<i>Common Name</i>
<i>Rhus glabra</i> L. (<i>Schmaltzia glabra</i> (L.) Small)	red sumac
<i>Rhus copallinum</i> L. (<i>Schmaltzia copallina</i> (L.) Small)	dwarf sumac
<i>Rhus leucantha</i> Jacq.	southern sumac
CYRILLACEAE	
<i>Cyrilla racemiflora</i> L.	leatherwood
<i>Cyrilla arida</i> Small	
<i>Cliftonia monophylla</i> (Lam.) Sarg.	titi
AQUIFOLIACEAE	
<i>Ilex Krugiana</i> Loesener	Krug's-holly
<i>Ilex verticillata</i> (L.) Gray	
<i>Ilex longipes</i> Chapm.	
<i>Ilex Curtissii</i> (Fernald) Small. (<i>I. decidua</i> Curtissii Fernald)	
<i>Ilex Cuthbertii</i> Small	
<i>Ilex decidua</i> Walt.	deciduous holly
<i>Ilex Buswellii</i> Small	
<i>Ilex ambigua</i> (Michx.) Chapm. (<i>I. caroliniana</i> (Walt.) Trelease)	
<i>Ilex myrtifolia</i> Walt.	yaupon
<i>Ilex Cassine</i> L.	dahoon
<i>Ilex vomitoria</i> Ait.	cassena
<i>Ilex cumulicola</i> Small. (<i>I. arenicola</i> Ashe)	
<i>Ilex opaca</i> Ait.	American holly
CELASTRACEAE	
<i>Euonymus atropurpureus</i> Jacq.	burning-bush
<i>Maytenus phyllanthoides</i> Benth.	
<i>Rhacoma Crossopetalum</i> L. (<i>Crossopetalum austrina</i> Gardner)	
<i>Gyminda latifolia</i> (Sw.) Urban	false-boxwood
<i>Schaefferia frutescens</i> Jacq.	boxwood
DODONAEACEAE	
<i>Dodonaea microcarya</i> Small	varnish-leaf
AESCULACEAE	
<i>Aesculus Pavia</i> L.	red-buckeye
ACERACEAE	
<i>Saccharodendron floridanum</i> (Chapm.) Nieuwl.	Florida-maple
<i>Argentacer saccharinum</i> (L.) Small. (<i>Acer dasycarpum</i> Ehrh.)	silver-maple
<i>Rufacer rubrum</i> (L.) Small. (<i>Acer rubrum</i> L.)	red-maple
<i>Rufacer carolinianum</i> (Walt.) Small	carolina-maple
<i>Rufacer Drummondii</i> (Hook. & Arn.) Small. (<i>Acer Drummondii</i> Hook. & Arn.)	red-maple
<i>Negundo Negundo</i> (L.) Karst. (<i>Rulac negundo</i> (L.) A. S. Hitchcock)	box-elder
SAPINDACEAE	
<i>Sapindus Saponaria</i> L.	soap-berry
<i>Sapindus marginatus</i> Willd.	soap-berry
<i>Talisia pedicellaris</i> Radlk.	
<i>Erothea paniculata</i> (Juss.) Radlk.	inkwood
<i>Hypelate trifoliata</i> Sw.	white-ironwood
<i>Cupania glabra</i> Sw.	

<i>Botanical Name</i>	<i>Common Name</i>
FRANGULACEAE	
<i>Krugiodendron ferreum</i> (Vahl) Urban.	
(<i>Rhamnidium ferreum</i> (Vahl) Sarg.)	black-ironwood
<i>Reynosia septentrionalis</i> Urban.	
(<i>R. latifolia</i> Griseb.)	red-ironwood
<i>Rhamnus caroliniana</i> Walt.	Indian-cherry
<i>Colubrina reclinata</i> (L'Her.) Brongn.	naked-wood
<i>Colubrina Colubrina</i> (Jacq.) Millsp.	wild-coffee
<i>Colubrina cubensis</i> (Jacq.) Brongon.	
TILIACEAE	
<i>Tilia porracea</i> Ashe	
<i>Tilia georgiana</i> Sarg.	
<i>Tilia heterophylla</i> Vent.	
<i>Tilia eburnea</i> Ashe	
<i>Tilia lasioclada</i> Sarg.	
<i>Tilia floridana</i> Small	
MALVACEAE	
<i>Pariti tiliaceum</i> (L.) St. Hil.	mahoe
<i>Pariti grande</i> Britton	mahoe
<i>Gossypium hirsutum</i> L.	wild-cotton
CANELLACEAE	
<i>Canella Winteriana</i> (L.) Gaertn.	wild cinnamon
CLUSIACEAE	
<i>Clusia flava</i> Jacq.	
<i>Clusia rosea</i> L.	
THEACEAE	
<i>Gordonia Lasianthus</i> (L.) Ellis	loblolly bay
LAURACEAE	
<i>Tamala Borbonia</i> (L.) Raf.	red-bay
<i>Tamala littoralis</i> Small	shore-bay
<i>Tamala humilis</i> (Nash) Small	silk-bay
<i>Tamala pubescens</i> (Pursh.) Small	swamp-bay
<i>Nectandra coriacea</i> (Sw.) Griseb.	
(<i>Ocotea Catesbyana</i> (Michx.) Sarg.)	lance-wood
<i>Sassafras Sassafras</i> (L.) Karst.	sassafras
<i>Misanteca triandra</i> (Sw.) Mez.	misanteca
MELASTOMACEAE	
<i>Tetrazygia bicolor</i> (Mill.) Cogn.	tetrazygia
TERMINALIACEAE	
<i>Conocarpus erecta</i> L.	buttonwood
<i>Bucida Buceras</i> L.	black-olive
<i>Laguncularia racemosa</i> Gaertn.	white-mangrove
MYRTACEAE	
<i>Eugenia buxifolia</i> (Sw.) Willd.	Spanish-stopper
<i>Eugenia axillaris</i> (Sw.) Willd.	white-stopper
<i>Eugenia anthera</i> Small	
<i>Eugenia rhombea</i> (Berg.) Urban	red-stopper
<i>Eugenia confusa</i> DC.	ironwood
<i>Ananomis simpsonii</i> Small	
<i>Ananomis dicrana</i> (Berg.) Britton.	
(<i>A. dichotoma</i> —FL. SE. U.S.)	
<i>Mosiera longipes</i> (Berg.) Small.	
(<i>Eugenia longipes</i> Berg.)	

<i>Botanical Name</i>	<i>Common Name</i>
<i>Mosiera bahamensis</i> (Kiaersk.) Small. (<i>Eugenia bahamensis</i> Kiaersk.)	
<i>Calyptranthes pallens</i> (Poir.) Griseb. (<i>Chytraculia chytraculia</i> —FL. SE. U.S.)	spicewood
<i>Calyptranthes Zuzygium</i> (L.) Sw. (<i>Chytraculia zuzygium</i> (L.) Kuntze)	myrtle-of-the-river
RHIZOPHORACEAE	
<i>Rhizophora Mangle</i> L.	red-mangrove
NYSSACEAE	
<i>Nyssa sylvatica</i> Marsh.	
<i>Nyssa biflora</i> Walt.	black-gum
<i>Nyssa ursina</i> Small	bear-gum
<i>Nyssa Ogeche</i> Marsh.	Ogeche-lime
<i>Nyssa aquatica</i> L.	tupelo-gum
<i>Svida alternifolia</i> (L.f.) Small	umbrella-cornel
<i>Svida stricta</i> (Lam.) Small	
<i>Cynoxylon floridum</i> (L.) Raf.	flowering dogwood
HEDERACEAE	
<i>Aralia spinosa</i> L.	prickly ash
ERICACEAE	
<i>Kalmia latifolia</i> L.	mountain laurel
<i>Oxydendrum arboreum</i> (L.) DC	sourwood
<i>Xolisma ferruginea</i> (Walt.) Heller	staggerbush
VACCINIACEAE	
<i>Batodendron arboreum</i> (Marsh.) Nutt.	sparkleberry
THEOPHRASTACEAE	
<i>Jacquinia keyensis</i> Mez.	joe-wood
ARDISIACEAE	
<i>Rapanea guayanensis</i> Aubl.	myrsine
<i>Icacorea paniculata</i> (Nutt.) Sudw.	marlberry
EBENACEAE	
<i>Diospyros virginiana</i> L.	persimmon
<i>Diospyros Mosieri</i> Small	persimmon
SAPOTACEAE	
<i>Chrysophyllum olivaeforme</i> L. (C. monopyrenum Sw.)	satineaf
<i>Sideroxylon foetidissimum</i> Jacq. (<i>S. mastichodendron</i> Jacq.)	mastic
<i>Dipholis salicifolia</i> (L.) A. DC	bustic
<i>Bumelia angustifolia</i> Nutt.	saffron-plum
<i>Bumelia lycioides</i> (L.) Gaertn.	buckthorn
<i>Bumelia lanuginosa</i> (Michx.) Pers.	gum-elastic
<i>Bumelia tenax</i> (L.) Willd.	tough-buckthorn
<i>Mimusops emarginata</i> (L.) Britton. (<i>M. Sieberi</i> A. DC.)	wild-sapodilla
SYMPLOCACEAE	
<i>Symplocos tinctoria</i> (L.) L'Her.	sweetleaf
STYRACACEAE	
<i>Halesia carolina</i> L. (<i>Mohrodendron carolinum</i> (L.) Brit.)	wild-olive tree
<i>Halesia parviflora</i> Michx. (<i>Mohrodendron parviflorum</i> (Michx.) Brit.)	
<i>Halesia diptera</i> Ellis. (<i>Mohrodendron dipterum</i> (Ellis) Brit.)	snowdrop-tree
<i>Styrax grandifolia</i> Ait.	storax

<i>Botanical Name</i>	<i>Common Name</i>
OLEACEAE	
<i>Fraxinus pauciflora</i> Nutt.	swamp-ash
<i>Fraxinus caroliniana</i> Mill.	water-ash
<i>Fraxinus Smallii</i> Britton	
<i>Fraxinus americana</i> L.	white-ash
<i>Forestiera acuminata</i> (Michx.) Poir.	
(<i>Adelia acuminata</i> Michx.)	forestiera
<i>Forestiera pōrulosa</i> (Michx.) Poir.	
(<i>Adelia segregata</i> (Jacq.) Small)	Florida privet
<i>Chionanthus virginica</i> L.	fringe-tree
<i>Amarolea megacarpa</i> Small.	
(<i>Osmanthus megacarpa</i> Small)	
<i>Amarolea americana</i> (L.) Small.	
(<i>Osmanthus americana</i> (L.) B. & H.)	wild olive
<i>Osmanthus floridana</i> Chapm.	
SOLANACEAE	
<i>Solanum verbascifolium</i> L.	potato-tree
EHRETIACEAE	
<i>Sebesten Sebestena</i> (L.) Britton.	
(<i>Cordia Sebestena</i> L.)	geiger-tree
<i>Bourreria revoluta</i> H.B.K.	
(<i>B. Radula</i> —FL. SE. U.S.)	rough-strongback
<i>Bourreria ovata</i> Miers, (<i>B. havanensis</i> — FL. SE. U.S.)	strongback
VERBENACEAE	
<i>Citharexylum fruticosum</i> L.	
(<i>C. villosum</i> Jacq.)	fiddlewood
<i>Duranta repens</i> L.	golden-dewdrop
AVICENNIACEAE	
<i>Avicennia nitida</i> Jacq.	black-mangrove
BIGNONIACEAE	
<i>Enallagma latifolia</i> (Mill.) Small.	
(<i>Crescentia ovata</i> —FL. SE. U.S.)	black-calabash
OLACACEAE	
<i>Schoepfia chrysophylloides</i> (A. Rich.) Planch.	
(<i>S. Schreberi</i> —FL. SE. U.S.)	whitewood
<i>Ximenia americana</i> L.	tallow-wood
RUBIACEAE	
<i>Pinckneya pubens</i> Michx.	fever-tree
<i>Exostema caribaeum</i> (Jacq.) R. & S.	princewood
<i>Casasia clusiifolia</i> (Jacq.) Urban.	
(<i>Genipa clusiifolia</i> Jacq.)	seven-year-apple
<i>Hamelia patens</i> Jacq.	hamelia
<i>Cephalanthus occidentalis</i> L.	buttonbush
<i>Guettarda elliptica</i> Sw.	velvet-seed
<i>Guettarda scabra</i> Vent.	rough velvet-seed
<i>Psychotria nervosa</i> Sw.	wild coffee
<i>Psychotria bahamensis</i> Millsp.	Bahaman wild-coffee
CAPRIFOLIACEAE	
<i>Sambucus Simpsonii</i> Rehder	
(<i>S. intermedia</i> —FL. SE. U.S.)	gulf-elder
<i>Viburnum rufidulum</i> Raf. (<i>V. rufotomentosum</i> Small)	southern black-haw
<i>Viburnum obovatum</i> Walt.	small-viburnum
<i>Viburnum Nashii</i> Small	Nash's viburnum

<i>Botanical Name</i>	<i>Common Name</i>
CARDUACEAE	
<i>Baccharis halimifolia</i> L.	groundsel-tree
<i>Baccharis glomeruliflora</i> Pers.	

CHECK LIST OF THE NATURALIZED TREES OF FLORIDA

JUNIPERACEAE	
<i>Biota orientalis</i> (L.) Endl. (<i>Thuja orientalis</i> L.)	Chinese-arborvitae
ARECACEAE	
<i>Cocos nucifera</i> L.	coconut
<i>Phoenix dactylifera</i> L.	date palm
CASUARINACEAE	
<i>Casuarina equisetifolia</i> Forst.	beefwood
JUGLANDACEAE	
<i>Hicoria Pecan</i> (Marsh.) Britton	pecan
ARTOCARPACEAE	
<i>Morus nigra</i> L.	black-mulberry
<i>Morus alba</i> L.	white-mulberry
<i>Papyrius papyrifera</i> (L.) Kuntze. (<i>Broussonetia papyrifera</i> (L.) Vent.)	paper-mulberry
<i>Toxylon pomiferum</i> Raf. (<i>Maclura aurantiaca</i> Nutt.)	osage-orange
<i>Ficus Carica</i> L.	common fig
ANNONACEAE	
<i>Annona squamosa</i> L.	sweet-sop
MORINGACEAE	
<i>Moringa Moringa</i> (L.) Millsp.	horseradish-tree
MALACEAE	
<i>Pyrus communis</i> L.	pear
AMYGDALACEAE	
<i>Amygdalus Persica</i> L.	peach
MIMOSACEAE	
<i>Albizia Julibrissin</i> (Willd.) Durazz.	julibrissin
<i>Albizia Lebbek</i> (Willd.) Benth.	woman's-tongue
CASSIACEAE	
<i>Parkinsonia aculeata</i> L.	Jerusalem-thorn
<i>Delonix regia</i> (Boj.) Raf.	royal-ponciana
<i>Poinciana pulcherrima</i> L.	dwarf-ponciana
<i>Tamarindus indica</i> L.	tamarind
FABACEAE	
<i>Robinia Pseudo-Acacia</i> L.	black-locust
<i>Daubentonia punicea</i> (Cav.) DC. (<i>Sesbania punicea</i> Benth.)	purple sesban
<i>Micropteryx Crista-galli</i> (L.) Walp. (<i>Erythrina Crista-galli</i> L.)	
RUTACEAE	
<i>Glycosmis citrifolia</i> (Willd.) Lindl.	glycosmis
<i>Poncirus trifoliata</i> (L.) Raf.	trifoliolate-orange
<i>Citrus Aurantium</i> L.	bitter-sweet orange
<i>Citrus sinensis</i> Osbeck	sweet-orange
<i>Citrus aurantifolia</i> (Christm.) Swingle	lime
<i>Citrus Limonum</i> (L.) Risso	lemon
<i>Citrus Medica</i> L.	citron

<i>Botanical Name</i>	<i>Common Name</i>
SIMAROUBACEAE	
<i>Ailanthus altissima</i> Swingle. (<i>A. glandulosa</i> Desf.)	tree-of-heaven
MELIACEAE	
<i>Melia Azedarach</i> L.	chinaberry
EUPHORBIACEAE	
<i>Triadica sebifera</i> (L.) Small. (<i>Sapium sebiferum</i> (L.) Roxb.)	Chinese tallow-tree
<i>Sapium glandulosum</i> (L.) Morong.	milk-tree
<i>Ricinus communis</i> L.	castor-oil plant
SPONDIACEAE	
<i>Mangifera indica</i> L.	mango
MALVACEAE	
<i>Thespesia populnea</i> (L.) Soland.	seaside-mahoe
BUETTNERIACEAE	
<i>Firmiana platanifolia</i> (L.) R. Br. (<i>Sterculia platanifolia</i> L.)	Japanese varnish-tree
PROTACEAE	
<i>Grevillea robusta</i> A. Cunn.	silk-oak
LAURACEAE	
<i>Camphora Camphora</i> (L.) Karst.	camphor tree
<i>Persea Persea</i> (L.) Cockerell	avocado
LYTHRACEAE	
<i>Lagerstroemia indica</i> L.	crape-myrtle
TERMINALIACEAE	
<i>Terminalia Catappa</i> L.	Indian-almond
MYRTACEAE	
<i>Psidium Guajava</i> Raddi.	guava
<i>Melaleuca Leucadendra</i> L.	cajuput-tree
SAPOTACEAE	
<i>Sapota Achras</i> Mill.	sapodilla
<i>Lucuma nervosa</i> A. DC.	egg-fruit
OLEACEAE	
<i>Ligustrum ovalifolium</i> Hassk.	California privet
APOCYNACEAE	
<i>Nerium Oleander</i> L.	oleander
SOLANACEAE	
<i>Nicotiana glauca</i> Graham	
VERBENACEAE	
<i>Vitex Agnus-Castus</i> L.	chaste-tree
BIGNONIACEAE	
<i>Catalpa Catalpa</i> (L.) Karst.	catalpa
<i>Crescentia Cujete</i> L.	calabash-tree

TAXONOMIC CHARACTERS AND HABITATS OF SOME OF THE MOST COMMON FLORIDA MYCETOZOA

CHARLOTTE B. BUCKLAND
Landon High School, Jacksonville

THE PURPOSE of this paper is to acquaint the interested but perhaps uninitiated scientist with some of the most common mycetozoa; hoping to stimulate this interest to such an extent that he will join the collectors of this organism. Thus, the scope of the knowledge of the Florida fauna will be further widened.

The mycetozoa comprise around 400 species placed in 53 genera which in turn, are grouped into 14 families. The taxonomic characters are based on the reproductive phase of the organism. This is a fructification producing spores that give rise to zoospores. The vegetative phase is called a plasmodium, the color of which is sometimes used as a diagnostic character. This paper refers to 10 genera and 13 species found in 4 Florida counties. This number is merely an indication of the number of the organism that may be found in this state. Specimens of the Florida species noted are in the hands of the writer except the specimens collected by Dr. Thaxter which are in the Farlow Herbarium at Harvard University and which have been examined by her.

As previously mentioned, the taxonomy of this group is based upon the structure of the fruiting bodies and the color and size of the spores. The fructifications are divided into two main groups: those in which the spores develop outside a sporophore belonging to the subclass Exosporeae, and those in which the spores develop inside a sporangium belonging to the subclass Endosporeae. In the Exosporeae there is but one family and one genus: the family, Ceratiomyxaceae; and the genus Ceratiomyxa.

During the fall of 1897, Dr. Robert Thaxter collected a specimen of *Ceratiomyxa fruticulosa* Macbr. variety *flexuosa* Lister at Coconut Grove, Florida. The specimen is interesting from the fact that it is a tropical form. The sporophores are long, slender, white, and produce externally, white, smooth, ovoid spores. The straight species of this genus is found everywhere, usually most abundant after a considerable amount of rain. Their dazzling, white sporophores catch the eye of the collector who may erroneously class them among the innumerable fungi.

The endosporeae are composed of 52 genera placed in 13 families. The sporangia are either simple or compound. The simple sporangia are either stalked or sessile or sessile sporangia with an irregular outline called, plasmodiocarps. The compound spo-

rangia are formed from the union of many sporangia and are given the term aethalia. Among the aethalia are found 2 very common forms *Lycogala epidendrum* Fr. and *Fuligo septica* Gmelin. *Lycogala epidendrum* Fr. resembles a miniature puff-ball growing in colonies on wood. The aethalia range in size from 3—15mm. It is cosmopolitan and has been collected from Leon and Duval counties. *Fuligo cinerea* Morg. was collected by Dr. Thaxter at Cocconut Grove, Florida, in the fall of 1897. It is a white aethalium not as common as the yellow *Fuligo septica* Gmelin that is frequently referred to as "Flowers of Tan." The aethalia of *Fuligo septica* Gmelin range in size from 2mm.—20 cm. From Clay county comes an example of the plasmodiocarp, *Hemitrichia Serpula* Rost, the sporangia of which form orange-yellow loops resembling a chain.

The simple fructifications are the most familiar ones and may be sessile or stalked, with or without lime, scattered clustered or heaped upon the substratum. Other sporangial characters are: the capillitium, a system of threads; the peridium, the sporangial wall; and the columella, a continuation of the stalk into the capillitium. To determine whether a sporangium is sessile or stalked; scattered, clustered or heaped is easily accomplished with the unaided eye. But the other structures must be determined with a microscope. A beautiful example of sessile heaped, spherical sporangia is a specimen of *Oligonema nitens* Rost. from Leon county. The sporangia are minute (0.2—0.4mm.), shining, olivaceous yellow, somewhat resembling insect eggs.

The presence or absence of lime is determined by microscopical examination of the sporangia mounted in water. The lime particles are in the form of round granules or stellate crystals. In a water medium, the round, lime granules ably demonstrate Brownian movement and are instantly recognized because of this phenomenon. *Physarum polycephalum* Schwein. collected from Duval county represents a stalked sporangium containing lime. This species with its medusa-like stalked sporangia is a joy for the beginner to encounter since it is easily recognized from its picture. The capillitium and the olivaceous-yellow peridium contain lime granules. Another stalked calcareous form is *Diachea leucopoda* Rost. found in Clay county. The stalks and columellae of this species are chalk white with lime. This particular specimen was collected in July 1937 and covered the leaves, grass, and stems of plants to such an extent that a 16-year-old girl exclaimed with wonder at the sight.

It is, perhaps, well to digress here, in order to explain the spore characteristics. Spore characters are necessarily microscopic due to their size, which range from approximately 4 micra—13 micra. The spore size remains surprisingly constant for a given species. The color of the spores places the mycetozoa in

the 2 orders of the group. In the first order, the spores are violet-brown or purplish-grey. The order comprises 5 of the 13 families of the Endosporeae. In the second order, the spores are variously colored but not violet-brown or purplish-grey. The color of the spores is determined when they are magnified and with transmitted light. The spores are diversely marked, such as: worted and reticulated. The spore markings are best studied under the oil immersion lens. The peculiar character of the spores of the mycetozoa separates the mycetozoa from fungi that might be confused with them.

Among the stalked sporangia with dark colored spores and without lime are two forms with interesting capillitia and columellae. In one form, the sporangium is distinct, the columella is long, and the threads of the capillitium are arranged in the form of a net with small meshes on the surface and large meshes near the columella. The sporangia are cylindrical, clustered and cinnamon-brown in color due to the color of the spore mass. In the field, the sporangia resemble the bristles of a small brush. This form belongs to the genus *Stemonitis* of which *fusca* is a renowned species. The specimen previously referred to is *Stemonitis ferruginea* Ehrenb. and has been collected from Leon and Clay counties. In the second form, the sporangia are distinct, spherical and the columella branches like a tree. The threads of the capillitium also form a network; however, there is no surface net. The peridium of this form is most interesting since it has the shining appearance of Christmas tree tinsel. A specimen of this form, *Lamproderma arcyrionema* Rost., has been collected from Leon county.

In the following specimens the spores are variously colored and the threads of the capillitium are sculptured. *Hemitrichia stipitata* Macbr. is a stalked form with subglobose, yellow sporangia of which the capillitial threads are in the form of a net and are sculptured with 4—5 smooth, spiral bands. This species seems to be abundant during the early summer and was collected in Duval county May, 1933. A red-colored sporangium sometimes sessile, sometimes stalked is *Hemitrichia Vesparium* Macbr. collected in Leon county. The capillitial threads of this species are red and studded with spines. The stalk, when present, and the peridium is red, also.

One of the most common mycetozoa is *Arcyria denudata* Wettstein which has been collected in Leon and Duval counties and is probably found in every county and country. It is a stalked form with a capillitium composed of a much branched net. If not weathered, the crimson, subcylindrical sporangia attract the eye at once, but if weathered the drab reddish-brown sporangia escape unnoticed. The capillitial threads are sculptured with cogs, spines, and half-rings. The stalk is hollow as

indicated by the presence within it of spore-like cells. Another common species of this genus is *Arcyria cinerea* Pers. collected in Leon county. It is similar to *Arcyria denudata* Wettstein except for its ashen color and the character of the capillitial threads which are marked with spines and warts.

The time to collect mycetozoa is after a few days of rain. They are found on logs, leaves, stems, pilei of fungi; in fact almost any moist substratum even the excreta of animals. If a good collecting ground is once discovered continue to return to that region because new species will develop as the season progresses. The Florida lime sinks should be excellent collecting grounds for the calcareous forms. Due to Florida's mild climate, the season should continue twelve months of the year.

The students of Florida's mycetozoa have only skimmed the surface of this rich field. The quantity and rarity of specimens remaining to be collected are manifold. The Everglades, alone, must contain many rare forms, perhaps new species. The lime sinks too, will surely reap a fertile harvest. In Florida, there are new fields to conquer in every Biological science and, certainly, this is true of the mycetozoa.

FLORIDA SNAKE VENOM EXPERIMENTS

E. ROSS ALLEN

Florida Reptile Institute

RELATIVE POTENCY OF VENOMS

POISONOUS SNAKES are born with fangs and venom, and I have seen them kill their prey with one strike when less than a day old. Is the venom of baby snakes as potent as that of the adults? Is there any difference between the venoms of snakes of different sizes? Does venom dried in the sun lose any of its potency? I did not know the answers to these questions, so, Kenneth Freeman, M.S., of the University of Florida, and I began some experiments on November 18, 1936, to find out. Some of the results of the experiments are shown in Table I. (Notice that the weight of the venom injected was 4 milligrams, and an ordinary pin measuring $1 \frac{1}{16}$ inches weighs 80 milligrams, 20 times as much as the venom used.)

TABLE I—THE RELATIVE POTENCY OF VENOMS FROM VARIOUS SNAKES

Snake	Amt. Venom Injected	Wgt. of Guinea Pig	Results
<i>Crotalus adamanteus</i> (Florida Diamond-back) 34 inch, male (Venom was clear white)....	4 mg	250 gm	Death in 1 hr 16 mins
<i>Crotalus adamanteus</i> (Florida Diamond-back) 56.5 inch, female	4 mg	250 gm	Death in 1 hr 54 mins
<i>Crotalus adamanteus</i> (Florida Diamond-back) baby, less than week old.....	4 mg	250 gm	Death in 2 hrs
<i>Bothrops atrox</i> (Fer-de-Lance) 61 inch, female.....	4 mg	250 gm	Death in 2 hrs 32 mins
<i>Agkistrodon piscivorus</i> (Cotton- mouth Moccasin) 58-inch, male	4 mg	250 gm	Death in 2 hrs 45 mins
<i>Micrurus fulvius fulvius</i> (Coral snake) medium size	bit leg of guinea pig	250 gm	Death in 3 hrs
<i>Agkistrodon piscivorus</i> (Cotton- mouth Moccasin) 38 inch, female	4 mg	250 gm	Death in 3 hrs 28 mins
<i>Agkistrodon piscivorus</i> (Cotton- mouth Moccasin) baby about week old	4 mg	250 gm	Death in 3 hrs 57 mins
<i>Bothrops atrox</i> (Fer-de-Lance) 52.5 inch, male	4 mg	250 gm	Death in 6 hrs 14 mins
<i>Bothrops atrox</i> (Fer-de-Lance) 61 inch, male.....	4 mg	250 gm	Death in 6 hrs 18 mins
<i>Crotalus horridus atricaudatus</i> (Canebrake Rattlesnake) about week old.....	4 mg	250 gm	Death in 7 hrs 45 mins
<i>Crotalus adamanteus</i> (Florida Diamond-back) 53.5 inch, female	4 mg	250 gm	Death in 8 hrs 55 mins
<i>Bothrops atrox</i> (Fer-de-Lance) 23.25 inch, female.....	4 mg	250 gm	Death in 14 hrs 26 mins
<i>Crotalus durissus durissus</i> (Tropical Rattlesnake) 48 inches	4 mg	250 gm	Death in 23 hrs 30 mins
<i>Agkistrodon piscivorus</i> (Cotton- mouth Moccasin) 53.5 inch, male.....	4 mg	250 gm	Death in 29 hrs 47 mins
<i>Crotalus adamanteus</i> (Florida Diamond-back) 58-inch, male	4 mg	250 gm	Death in 45 hrs 44 mins

Below are the results of experiments performed on dogs to determine the relative potency of venoms. In each case 6 milligrams of venom to one pound of dog was given:

1. Baby rattlesnake venom; dog died in 3 hours 50 minutes.
2. Pigmy rattlesnake venom; dog died in 9 hours.
3. Diamond-back rattlesnake venom; dog died in 12 hours 35 minutes.

4. Baby Cotton-mouth venom; dog died in 15 hours 25 minutes.
5. Adult Cotton-mouth venom; dog died in 30 minutes.
6. *Crotalus atrox* venom (desiccated); dog died in about 35 hours.
7. *Crotalus atrox* venom (sun-dried); dog died in about 76 hours.

Following is a list of results of experiments carried out to determine whether there is a definite time relation corresponding to the given dosages of venoms (Diamond-back Rattlesnake).

<p><i>2 Milligrams of Venom Per Pound of Dog:</i></p> <p>No. 1 dog died in 40 hours 10 minutes. No. 2 dog died in 24 hours 15 minutes.</p> <p><i>3 Milligrams of Venom Per Pound of Dog:</i></p> <p>No. 1 dog died in 9 hours 40 minutes. No. 2 dog died in 33 hours 30 minutes.</p>	<p><i>4 Milligrams of Venom Per Pound of Dog:</i></p> <p>No. 1 dog died in 6 hours. No. 2 dog died in 7 hours 25 minutes.</p> <p><i>6 Milligrams of Venom Per Pound of Dog:</i></p> <p>No. 1 dog died in 4 hours 30 minutes. No. 2 dog died in 15 hours 25 minutes.</p>
--	---

EFFECT OF COTTON-MOUTH MOCCASIN (*Agkistrodon Piscivorus*) VENOM ON VARIOUS SNAKES

It is popularly known that the King Snake is immune to the poison of the Rattlesnake and the Cotton-mouth Moccasin, but little is known about the effects of venom on other snakes. Therefore, Kenneth Freeman, chemist, and I started a series of experiments to find out the effect of venom on various snakes. This, of course, is by no means conclusive but only indicates the results obtained. To prove anything definite, we will have to continue the experiments using hundreds of snakes.

In these experiments, venom of our own production that had been desiccated and kept in a cool dark place was used. The venom was weighed on balance scales made by Eimer and Amend. The snakes were weighed on a regular 25-pound spring scale. The injections were made with a hypodermic needle. The dried venom was diluted with distilled water just before each injection.

1. *Agkistrodon piscivorus*: This specimen weighed eight ounces and was injected with 150 milligrams of moccasin venom midway, just under the skin on the right side. The dose was divided and injected in two different places. Results: The snake died in three hours. When the skin was removed, the place where the injections had been made was discolored from bloody coagulation for several inches up and down the body.
2. *Agkistrodon piscivorus*: This specimen weighed five and a half ounces and was injected with 100 milligrams of venom on the right side about midway. This dose was divided and injected in two places. Result: There was some swelling, but the snake recovered in four days and continued to live.
3. *Agkistrodon piscivorus*: This specimen weighed eight ounces and was injected with 100 milligrams of venom on the right side about midway in two places. Result: There was swelling, as in the others, but the snake recovered in five days. On the seventh day, I killed the snake and removed the skin to examine the injected spot and found it to be slightly discolored for five inches up and down the body.
4. *Agkistrodon piscivorus*: This specimen weighed one-third pound, was injected with 100 milligrams of venom and recovered.

5. *Agkistrodon piscivorus*: This specimen weighed one-half pound, was injected with 100 milligrams of venom, and recovered.
6. *Crotalus adamanteus*: This specimen weighed one pound and was injected with 200 milligrams of venom on the left side. The snake died in 30 hours. Upon examination, I found the injected area very discolored with coagulated blood.
7. *Sistrurus miliarius barbouri*: This specimen weighed three ounces, was injected with 25 milligrams of venom and died in about 10 hours.
8. King Snake (*Lampropeltis getulus getulus*): This specimen weighed one pound four ounces and was injected with 200 milligrams of venom. There was no swelling evident and the snake continued to live without any ill effects.
9. Indigo Snake (*Drymarchon corais couperi*): This specimen weighed one and a half pounds and was injected with 200 milligrams of venom. The snake did not show any ill effects, except that it became sluggish and remained very quiet. There was a slight swelling evident, but the snake recovered.
10. Congo Water Snake (*Natrix cyclopion floridana*): This specimen weighed one-half pound and was injected with 100 milligrams of venom in the right side just under the skin. There was a slight swelling, but the snake remained active and fully recovered.

We continued the same experiments, using snakes from Central America, also alligators and turtles, the results of which are as follows:

11. Jumping Viper (*Bothrops nummifera*): This specimen weighed one-fourth pound, was injected with 75 milligrams of venom, and died in about 13 hours.
12. Tropical Rattlesnake (*Crotalus durissus durissus*): This specimen weighed 2 ounces, was injected with 25 milligrams of venom, and died in 45 minutes.
13. 2-foot alligator weighing 1½ pounds. This specimen was injected with 150 milligrams of Cotton-mouth Moccasin venom. The result was death in about 14 hours.

EFFECT OF PIGMY RATTLESNAKE (*Sistrurus Miliarius Barbouri*)
VENOM ON THE CORAL SNAKE (*Micrurus Fulvius Fulvius*)

We have a concrete pit six feet square and five feet deep in which we keep Coral snakes and Pigmy Rattlesnakes. On September 15, 1937, David Boyer, an employee at the Florida Reptile Institute, put a new Coral snake into the pit. Almost immediately a small Pigmy Rattlesnake bit the Coral snake on the back, two inches back of the head. The Coral snake apparently had disturbed the Pigmy with its excited movements. In a few minutes the Coral snake lay still and swelling was noticeable around the place where it had been bitten. A few hours later there was a great amount of swelling, increasing the size of the Coral snake's neck about one-third its normal size. Twenty-four hours later, the Coral snake was dead and it was very evident that death was caused from the venom of the Pigmy Rattlesnake.

EFFECT OF COTTON-MOUTH MOCCASIN (*Agkistrodon Piscivorus*)
VENOM IN THE EYE

I was demonstrating with a four-foot Cotton-mouth Moccasin to show the fangs; the snake bit a stick suddenly and some of the venom squirted out and quite a bit of it went directly into my left eye. Immediately there was a smarting and burning sensation and it was difficult for me to see with that eye. The pain continued as my eye became very bloodshot and inflamed. I immediately washed it out with water, which seemed to help some, and continued the treatment with an eye-cup containing boric acid solution. In about an hour the pain left, and in two hours my eye had cleared up.

This happened April 11, 1934, and it is now November, 1937, and I have suffered no bad results from the venom in my eye, even though I have had both Cotton-mouth Moccasin venom and Rattlesnake venom squirted in my eye since that time.

SWALLOWING SNAKE VENOM; ITS TASTE AND EFFECT

It was quite accidentally that I first tasted snake venom. A Cotton-mouth Moccasin bit down on a stick opposite my face and the venom spurted into my mouth. Often, since that time, I have tasted the fresh venom by dipping my finger into it. Twice I have swallowed a half teaspoon of Moccasin venom.

Once, and this was the only time, I swallowed a teaspoonful of Moccasin venom. This large dose of venom caused my mouth to pucker, very much like the effect of a green persimmon. The astringent effect lasted six hours, and was not very pleasant. My lips remained irritated and slightly sore for over a day.

Moccasin and Rattlesnake venom, being a protein, is digested in the stomach and the poisonous properties are destroyed.

In Noguchi's book, *Snake Venoms*, which gives a great deal of information about snake venoms, he states:

Lacerda, Calmette and C. J. Martin state that the venoms of *Lachesis lanceolatus* and *Pseudechis* may cause intense inflammation and hemorrhagic changes in the alimentary tract, when sufficient quantities of these venoms are given by the mouth. If the dosage be sufficiently large death follows usually, their administration, with the usual venom-poisoning symptoms.

With the venom of cobra, alimentary administration gives somewhat different results from those obtained in the case of crotaline venoms. Brunton and Fayrer observed that fatal effect is produced in animals when cobra venom is given from the digestive tract by feeding.

Fraser points out that absorption of cobra venom from the stomach is very slight. In rats and cats, nearly 1,000 times the subcutaneous lethal dose was given without fatal effect. As a result of such administration of venom, the serum of these animals was found to contain a certain amount of antitoxin.

Calmette failed to confirm Fraser's experiments, as he always found the venom to act fatally when given by the mouth in large dosage.

Kanthack fully confirms Fraser's observations that immunity can be secured by feeding the venom to animals.

SNAKE BITES IN FLORIDA RECORDED BY FLORIDA REPTILE INSTITUTE 1934-1937

Snake	1934		1935		1936		1937	
	Bites	Deaths	Bites	Deaths	Bites	Deaths	Bites	Deaths
Diamond-back								
Rattlesnake	6	1	24	7	20	8	15	7
Pigmy Rattlesnake...			10	0	13	0	5	0
Cotton-mouth								
Moccasin	7	2	11	0	17	0	7	0
Coral Snake	1	0						
Copperhead							1	0
Species unknown	1	0	2	0	3	1	2	0
TOTALS	15	3	47	7	52	9	30	7

At the American Red Cross First Aid and Life Saving Institute, I helped administer first aid in a case of Copperhead bite in 1931. Miss Jim Haile, a student, was climbing out of a lake onto the bank when she was bitten by something on her left hip through two layers of bathing suit. She did not see anything but felt a burning pain and complained to a doctor. Upon examination, two fanglike punctures were found, and the Institute doctor made small incisions. Then, to verify our suspicions, I looked for the snake and found a small Copperhead near the water's edge crawling away from the place where Miss Haile had been bitten.

The characteristic symptoms increased and now, certain that it was a poisonous snake, we went to work hopefully. The doctor injected antivenin while I applied suction on the two incisions. The area around the bite became swollen and dark in color and in about two hours had spread around the bite for four inches. The swelling was reduced, probably due to the treatment; however, Miss Haile remained sick for five days. She recovered fully, with no bad results or complications. As this was a mild case of poisoning, I judged that the snake, being small and biting through two layers of wool bathing suit, was not able to inject a full dose of venom, as it could have under more favorable circumstances. This was one of my first lessons that only a drop of venom can cause serious trouble. I decided then and there to handle poisonous snakes more carefully, and with much more respect for their venom.

On one collecting trip in the Everglades, Bill Piper, my assistant, was bitten by a Pigmy Rattlesnake as he turned the snake loose to drop it in a sack. The Pigmy sank both fangs into the index finger, and Bill pulled the snake off. Carol Stryker, Director of the Staten Island Zoo, Staten Island, New York, was with us at the time as our guest, and he immediately treated Bill with a suction outfit. In spite of the treatment, however, there was a severe pain and swelling for about 24 hours.

MILKING SNAKES FOR VENOM

In collecting snake venom the first problem is securing the snakes. We collect them ourselves when time permits, and pay our men an average of \$2.00 each for the snakes uninjured and of a worthwhile size. We keep our snakes for milking in a concrete pit 30'x30', but even under favorable conditions we lose too high a percentage of them, particularly after handling them in the milking process.

We have arranged a box-like table in our pit, with small frames for securing the milking glasses, and with an opening in the center of the table in which to drop the snakes after finishing the milking extraction.

In the actual milking process we catch the snake back of the head by hand, using the snake hook to guide the snake's head or to move it around. We then force the fangs over the edge of the glass and allow the venom to run down into the glass. From one good fresh rattlesnake we may get as much as 3 cc. of venom. This venom must be dehydrated before shipping. In one milking we secured one liquid ounce and found that when it was dehydrated we had about 6 grams of venom.

We have found that the amount of venom extracted is affected profoundly by the number of times the snake has been milked, by the weather, and by the health and condition of the snake.

USES OF VENOM

The Cotton-mouth Moccasin venom is being used for hemorrhagic conditions of the blood. The venom solution is injected in small quantities in the patient which strengthens the blood vessels and prevents bleeding. Diamond-back Rattlesnake venom is being used in experimental work on other diseases and is being used in place of morphine. Fer-de-Lance venom is being used as a local coagulant and is applied directly and stops bleeding at once.

ALLERGIC HYPERSENSITIVITY AND THE FOUR BLOOD GROUPS

LUCIEN Y. DYRENFORTH

*St. Luke's, Riverside, and Duval County Hospitals,
Jacksonville*

BY THE term allergy is meant the natural tendency of an individual to develop certain chronic diseases such as asthma and hayfever. This is the ordinary meaning of the word.

Allergic hypersensitivity is the term used to denote this natural process as contrasted to anaphylaxis, or hypersensitization produced by artificial inoculation. This hypersensitivity is therefore a specific hypersensitivity, which is to say, an individual may be sensitive to a certain substance to a degree considered abnormal.

The specific exciting substance is usually protein in nature, in the case of asthma, hayfever, urticaria, migraine, tuberculin reaction, and so on. The involved protein substance may be in the form of pollen, in asthma or hayfever, or some food product, or some bacterial infection. In such case this exciting substance is termed "allergen", by reason of its antigenic powers of arousing antibody formation in the system of the inoculated individual. This, also, is stated in the usual sense relating to the concepts of immunity.

In a previous publication[†] it was brought out that individuals belonging to blood Group B appeared, from clinical observation, to experience the most acute forms of allergic disease, and it was suggested, on the basis of a statistical survey, that a relatively larger proportion of these Group B persons become hypersensitive than do those of the other groups. No attempt was made to base the premise upon biological grounds other than mere clinical observation. This is important, for it may well be considered from a genetic approach that would tend to give it definite experimental credence. The fact that the blood groups are heritable characters, mendelian dominant in nature, lends plausibility to the thesis that linkage may explain the appearance of allergic manifestations in individuals from Group B matings.

This conception is not entirely new, and there is definite opposition to such argument, principally because of the difficulty to be encountered in demonstrating linkage in families; because of the present paucity of data relating to linkage with the blood groups; and because of improbabilities connected with the 24-chromosome cell nucleus of the human; that is, one case of linkage per twenty-four traits studied.

The burden of this investigation is, therefore, not to attempt to prove impossibilities, but to assemble some data of positive nature regarding the number of individuals showing definite hypersensitiveness plotted against their respective blood groups. If a sufficiently large number of any group is found to possess specific hypersensitivity, then it will be of interest to make familial studies; for the mere fact of chance linkage is enough to warrant scrutiny of these factors. Since these four phenotypes are definitely heritable, and since Group B is especially inter-

[†]See reference at end of paper.

esting because of its freedom from sub-groups, the equally heritable factors of allergic hypersensitivity may after all be related.

It is hardly necessary to say that only the three groups, represented by the specific agglutinogens A and B (groups A, B, and AB), and the one group represented by lack of a specific agglutinin (group O) are being considered. The sub-groups, represented by A₁, A₂, A₁B and A₂B are not considered separately; nor are the more recently discovered (1927) groups, determined by the agglutinogens M and N, taken into this consideration.

In the former study it was brought out that Group B individuals were relatively more susceptible to allergy, based upon 322 persons appearing at random for blood transfusion typings, regardless of any specific history. Since that time a further, more intensive study has been made upon allergic subjects. These were selected from among prospective blood donors known, or subsequently proved, to be allergic; and from definitely allergic patients appearing at allergy clinics or under treatment. The figures, of course, have been checked for duplication and other errors. Only adults with fully established groups have been entered, the youngest 16 years, the eldest 60.

For the sake of reference it is here stated that the distribution of the four groups is as follows:

O	43%
A	40%
B	7%
AB	10%

Group B is thus the rarest, AB next, and groups O and A forming by far the larger percentage.

In material the sexes were about evenly represented. The black and white races were also fairly equitable in distribution. This is interesting to note, in that it has frequently been stated that aboriginal races are predominantly group A, and that they are not susceptible to allergic manifestations. Our figures appear to speak for evident blending of racial characters in this respect, which fact may have some bearing upon the case for or against linkage.

In this more recent study of chosen allergic individuals the figures are once again significant of a possible Group B—allergy linkage.

Ninety-one individuals were typed.

	O(43)	A(40)	B(7)	AB(10)
Groups, No. of Patients	24	55	10	2
Group % of whole	26.4	60.5	11.0	2.1
Factor of incidence	0.61	1.51	1.6	0.2

Conclusions. From these figures several possibilities present themselves, only one of which will be discussed. It is evident that the incidence of allergy among Group B individuals is greater than in the other groups; that is, if projected on to a large scale, all factors being equal, there would be a definitely larger proportion of "B" individuals possessing allergic hypersensitivity. Group B may be linked with a gene for this trait. This supposition would be compatible with the conception that a primordial genotype R gave rise to phenotypes A and B by mutation, and that later there was formed an incomplete linkage between the factors for agglutinin B and a tendency for allergic hypersensitivity. Being a mendelian dominant this character would necessarily survive the haphazard intermatings of the established groups, maintaining its identity.

This condition, if proved to exist, may be the basis for certain other disease linkages, and may some time serve as an index for their diagnosis and treatment.

Future studies will comprehend the further accumulation of data from typing allergic individuals with a view to extending the proof, if possible, of a preponderance of this tendency among Group B individuals.

REFERENCE

Blood Groups and Allergy: A statistical review. *The Southern Medical Journal*, Vol. 29, number 6, pages 617-618, June 1936, by Dr. Lucien Y. Dyrenforth, Jacksonville, Fla..

AN AMPLIFIER FOR SMALL THERMAL CURRENTS

DUDLEY WILLIAMS and RICHARD TASCHEK

University of Florida

IN THE conventional type of infrared spectrometer the dispersed radiation is detected by means of a thermocouple or thermopile. In connection with the thermal element a high-sensitivity galvanometer is used, the intensity of the radiation being measured by the deflections obtained. This simple arrangement is satisfactory in the near infrared region—from 1.5μ to 7.5μ . However, beyond 7.5μ the intensity of the energy emitted by ordinary sources of infrared radiation—the Nernst Glower and the Globar—is very low. In order to work in this region of long wavelengths one must employ an amplifier.

It has been found by other workers in infrared spectroscopy that ordinary forms of resistance-coupled vacuum-tube amplifiers

are unsuited for use in amplifying small thermal currents, a fact due in part to the comparatively low resistance of the thermocouples and thermopiles. Hence, it was decided in the present case to construct an optical amplifier employing barrier-layer photo-electric cells. The general scheme used may be seen from Figure I:

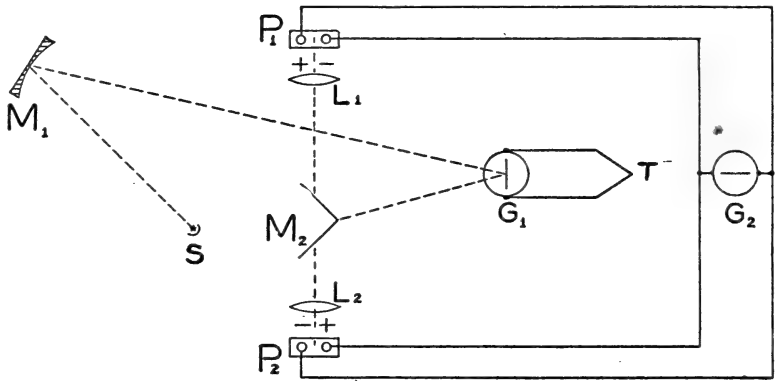

Figure I

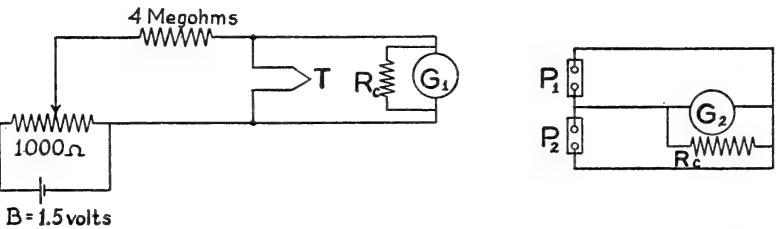

Figure II

Light from a source S (the filament of an auto headlight) is reflected from the surface of a concave mirror M_1 to the mirror of a galvanometer G_1 . From this galvanometer the light passes to right-angled mirror M_2 which divides the beam into two equal parts when no current is passing through galvanometer G_1 . After the original beam has been separated by M_2 , the two resulting beams are focused on the barrier-layer photo-cells P_1 and P_2 by the lenses L_1 and L_2 , respectively. The photo-cells are connected to a second galvanometer G_2 so that their E.M.F.'s are in opposition. This parallel connection keeps the total external resistance in the G_2 circuit constant and independent of relative illumination on the photo-cells. Thus, when the amounts of light falling on them are equal, no current flows through G_2 . However, if the galvanometer G_1 is used in connection with the thermopile T , a small deflection of G_1 results in a large deflection of G_2 , since the amount of light falling on one photo-cell is increased while that falling on the other is decreased. The deflection of galvanometer G_2 is read by means of a lamp and scale and is found to be directly proportional to the deflection of G_1 for small deflections.

The barrier-layer photo-cells are "Electro-Cells" prepared by Loewenberg. Their sensitivity is higher than that of most commercially available cells; the sensitized surface is circular and is 4.5 cm in diameter. Galvanometer G_1 is a Type HS Leeds and Northrup instrument, and G_2 is a Type R galvanometer made by the same firm. The characteristics of these instruments are shown below:

	Sensitivity (Per mm at 1 meter) (Micro-volts)	Period Seconds	Resistance Damping (Ohms)	Coil (Ohms)
G_1	0.2	5	40	17
G_2	0.5	5	27	12

In the calibration of the amplifier the circuit shown in Figure II was used.

Small E.M.F.'s can be applied to G_1 from the 1000 ohm potentiometer connected across the dry cell B. For a given setting of the potentiometer a deflection of galvanometer G_1 was read directly and the corresponding deflection of the second galvanometer G_2 recorded. A comparison of these deflections (at the same scale distance) will give an idea of the amplification obtainable; thus, we may set

$$\text{Amplification} = \frac{\text{Deflection of Galvanometer } G_2}{\text{Deflection of Galvanometer } G_1}$$

It is found that the amplification can be varied over a considerable range by varying the current through the filament of the auto lamp; however trial has shown that an amplification of about 250 is all that can be used conveniently due to mechanical vibrations in the building. (All vibrations of the first galvanometer are amplified.)

The deflections of the second galvanometer G_2 are read at a scale distance of 6 meters. Hence, for every 1 mm deflection of G_1 at a distance of 1 meter, a deflection of $6 \times (250)$ millimeters is obtained from G_2 . Thus, the sensitivity of the amplifier as a unit is given by:

$$\text{Sensitivity} = \frac{0.2 \times 10^{-6}}{1.5 \times 10^3} = 1.3 \times 10^{-10} \text{ volts/mm}$$

Under working conditions deflections of G_2 cannot be read closer than millimeters, and it is found to be desirable to work at lower amplifications, since the above sensitivity is close to the Brownian limit for galvanometer measurements.

With the aid of this amplifier it will be possible to extend the range of spectral energy to be investigated from the former upper limit of 7.5μ to about 15μ . At the present time the amplifier is being used in investigations of the structure of liquid crystals and of sugars. The authors wish to thank the Florida Academy of Sciences for a grant which was used in the construction of the instrument.

ABSTRACTS*

THE INFRARED ABSORPTION OF VITAMINS C AND D

LEWIS H. ROGERS
University of Florida

THE SPECTRUM of Vitamin C has been published in the *Journal of the American Chemical Society* in the 1937 volume. The spectrum of a saturated solution of Vitamin D is shown in the figure below.

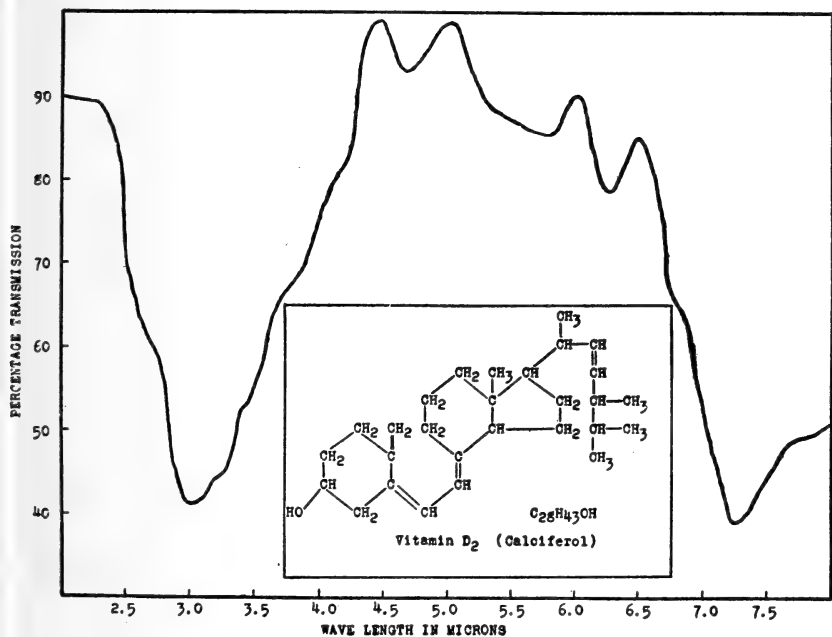

*It is intended to file complete copies of as many as possible of the papers abstracted in this section with the American Documentation Institute from whom it will then be possible to obtain at a nominal cost microfilm copies or photoprint copies readable without optical aid. *Absorption Spectrophotometry and Its Applications* by Lewis H. Rogers, an abstract of which appeared in the PROCEEDINGS, Vol. I (1936), p. 147 has been filed in this manner. The complete paper may be obtained from the American Documentation Institute, 2101 Constitution Avenue, Washington, D. C. by ordering Document 1126, remitting thirty-five cents for copy in microfilm, or \$1.70 for photoprints.

TRAITS IN THE NEUROTIC INVENTORY

CHARLES I. MOSIER
University of Florida

A PREVIOUS study of the forty most significant symptoms in the Thurstone Neurotic Inventory by the methods of multiple factor analysis revealed evidence of eight traits of the neurotic personality. These traits were tentatively identified as cycloid tendency, depression, hypersensitiveness, social introversion, inferiority feeling, stage fright, cognitive defect, and autistic tendency. Using these forty symptoms, scales were developed to yield approximate measures of each of the eight traits. The entire Neurotic Inventory was administered to two hundred college students, and for each student a score in each of the eight traits was obtained. The intercorrelations among the eight scales were low, and no greater than would be expected from the overlapping of items common to two scales, indicating that at least eight traits are necessary to describe the neurotic personality.

For each of the 178 items of the inventory which showed response frequencies between 10% and 90% the correlation coefficient between item and each of the eight scales was obtained. From the knowledge of the extent to which each item was measuring the trait determined by the scale, it was possible to extend the hypotheses concerning the nature of the traits. The trait-scale of cycloid tendency shows confirmation of a tendency toward emotional instability as a valid trait. A trait of depression as distinct from emotional instability is adequately confirmed, though the relations between depression and social introversion remain to be clarified. The existence of the trait of hypersensitiveness and its identification are both strikingly confirmed. The trait of social introversion is borne out by the new evidence. Items apparently social in nature are related either to depression or to social introversion, but not to both. The trait scale intended to measure inferiority feeling yields ambiguous results. The nature of this trait, and its relation to social maladjustment, require further investigation. Concerning the trait scales intended to measure cognitive defect and autistic tendency, no conclusions can be drawn.

PHILOSOPHICAL INTEGRITY IN SCIENCE TEACHING

HAROLD RICHARDS
Florida State College for Women

AN EFFORT to establish a criterion by which to determine what material should be included in undergraduate science courses, and how it should be presented. Illustrations drawn from chemistry, physics, astronomy, biology and psychology are used in the search for a sound criterion. The deficiencies of the most widely stressed form of the periodic table, including those revealed by the facts of isotopes, are discussed briefly to illustrate the distinction between fundamental significance and professional convenience. The criterion of philosophical integrity is applied to the practice of continuing to stress concrete atomic models known to be unsound. The concepts of law and of chance; the dogmatic aspects of current scientific materialism; and the misuse of graphical analogies in an attempt to convey the illusion of explaining a reality which is inherently incapable of being pictured, are other subtopics. Several college texts are cited to serve as examples of the kind of teaching which has led to the demand for greater significance and philosophical validity in science courses. The conclusion is reached that the aims of introductory

science courses of the newer type will be defeated if a nostalgic affection for scientific heirlooms is permitted to seduce us into parading outmoded shoptalk under the guise of significant truth. This approach quite easily leads teachers and authors into the error of treating students for whom technical difficulties must be minimized, as if they were necessarily juvenile in a cultural sense, and fails to give that integrated view of present realities which the student has a right to expect and which philosophical integrity demands.

THE DIVISION OF LABOR IN THE NATURAL SCIENCES

JOHN P. CAMP
University of Florida

THE PAPER is concerned with specialization in the education, interests, and work of the teaching, research, and administrative personnel in the broad field of the natural sciences, which are peculiarly (and possibly a little boldly) defined for the purposes of this discussion as the collection of these very general divisions: Logic, Mathematics, Physics, Chemistry, Biology, and any other which may be yet to come. Just what knowledge is excluded by this definition is not clear.

The primary purpose is to lament the obvious fact that there is a considerable lack of understanding and appreciation between those laboring in different subdivisions and sub-subdivisions of these sciences.

A secondary purpose is to indicate that the general causes of this unfortunate condition lie in the inevitable course of historical development, and the present inadequacy of systems of education. And finally an attempt is made to show that the condition is no longer inevitable or necessary and is to be remedied chiefly by further educational developments. A further, and perhaps not inappreciable contribution might be made by organized adult education of the educated.

TORREYA WEST OF THE APPALACHICOLA RIVER

HERMAN KURZ
Florida State College for Women

THE TREES belong to the genus *Torreya* or *Tumion*, which is a conifer that looks somewhat like a yew. In fact, its full name, *Torreya taxifolia*, means "yew-leaved *Torreya*." Because of its odorous leaves and wood, it has borne such English names as stinking cedar and polecat wood. It has also been nicknamed gopher wood—possibly an allusion to the reputed material of Noah's Ark. But lately the old folk names have been giving way, partly, to the scientific Latin, so that to scientists and the general public alike it may eventually have the same name.

In earlier geologic times the genus was worldwide in its distribution, but during the Ice Age it was cut down to a few relict patches—one in Florida, larger ones in California, Japan, and China.

The Florida *Torreya* trees, a distinct species, are found mainly in a small block of land just east of the Appalachian River in the north part of the state. In the books all the trees are declared to be on the east bank of the river.

However, in 1885 a noted Southern botanist, Dr. A. W. Chapman, found a few trees about half a dozen miles west of the river, and so reported in

one of his publications. When so few individuals of a species exist, the discovery of even a dozen new ones is a matter of some importance. But the find was lost sight of, and from then until now apparently has never been mentioned.

There are about 60 trees, ranging in height from 18 inches to 30 feet, scattered over about an acre of ground. Their assorted sizes constitute evidence that the trees are reproducing, an encouraging sign for their survival. Mixed with them are larger trees, mainly magnolias and beeches—a common timber type in northern Florida.

The locality is now known as Dog Pond, near Lake Ocheesee. In Dr. Chapman's time it was more romantically designated as Cypress Lake.

BANANA WATERLILIES

ERDMAN WEST

University of Florida

THE LARGE number of wild ducks of many species that winter in Florida make the subject of duck food an important one. Among the important sources of supply are ponds containing "banana waterlilies." This term has been found applied to two plants very different botanically but quite similar in several gross characters. The plant usually referred to in literature as "banana waterlily" is known botanically as *Castalia flava*, a true waterlily with yellow flowers. The plant usually designated "banana waterlily" by Floridians is *Nymphoides aquaticum* in the buck bean family, often called floating heart. Both plants have similar leaves and similar clusters of tubers, hence the common name, but the flowers are very distinct and tubers are borne on different parts of the plant. *Castalia* bears its tubers deep in the mud one beneath each node of the long runners that spread through the ooze, while *Nymphoides* bears its tubers, one on each of the many peduncle-petiole combinations that are produced by each crown. If the tubers of the two plants have equal food value, the *Nymphoides* would be much more important because of its greater abundance and accessibility. No chemical analyses or feeding experiments seem to be on record.

THE FLORA OF FORT GEORGE ISLAND

MRS. W. D. DIDDELL

Jacksonville, Florida

FORT GEORGE ISLAND is the fourth from the outside end of a chain of islands in the mouth of the St. Johns River, separated from each other and from the Main Land by salt marshes and the mouths of several small creeks. It was called Alimacani by the Timuqua Indians, from whom it was taken by the Spanish and held successively by the French, Spanish, English, Spanish, United States, Confederacy, United States. Its elevation ranges from a little above sea level to the peak of "Mount Cornelia" with an elevation of 64 feet. It is characterized by shell-heaps with heavy humus top-soil which thins down to hard packed oyster shell at shore line. Its flora includes pteridophytes, palms, conifers, orchids, deciduous and evergreen trees and shrubs, climbers, and herbaceous plants. Fort George Island is the plant collector's paradise by reason of the diversity of its species over so small an area; many of the species are not found elsewhere in this section of the state. *Cheilanthes*

microphylla and *Pepperomia cumulicola* were first discovered here by early botanists.

SCIENTIFIC THEORY AND POSSIBLE PRACTICE OF THE BICHROMATIC SCALE

MAX F. MEYER

University of Miami

THE HISTORY of music is largely a growth through trial and error. But scientific theory and experiment have always been of service, too. Subdivision of the twelve-tone chromatic scale can be scientifically defended only when the result is a twenty-four-tone scale, called bichromatic or quartertone scale. Any scale of just intonation (untuned) is a scientific dream, but practically not wanted.

The use of a quartertone (24 keys) instrument is no revolution in music. This scale can be used to enrich music in quite orthodox ways (1) by occasionally offering three melodic variations to a theme for only two (major-minor, so-called) variations; (2) by permitting to suggest to the hearer certain chords forcefully which are now a rare psychological accident in the hearer; (3) this third is the least important, by permitting a key instrument to approach a sliding pitch.

On the American continent only one quartertone instrument with a single keyboard exists. This unique instrument will be demonstrated to the eye and to the ear. It is a reed organ. Since it is "home-made," this is not offered to the public as "a concert" but as a laboratory demonstration. The disadvantages of the only existing European design of a true bichromatic keyboard will be pointed out.

In theory, the use of fractions (as $1/2$, $5/8$, $6/7$ etc.) must be discarded as leading to complexities unthinkable except to a "lightning calculator." In the analysis of a piece, each tone must be arithmetically expressed, not by the two members of a fraction but by a single number. This becomes possible through discarding (i.e., not writing nor speaking) any factors which are powers of 2. Say 3 instead of 12. Further, only 1, 3, 5 and 7 (no other prime numbers) must be admitted as factors, on psychological grounds. Arithmetical thinking of actual music then becomes simple enough to be possible, though not easy. The physiological theory of music is of course chemistry.

The only numerical symbols which in performance call for a quartertone scale are 35 and products like 3×35 or 5×35 . All other numbers, like 135 or 225 or 405, are expressible in playing the semitone scale. Any novel musical practice but rarely will call for a quartertone, and the introduction of the bichromatic scale must not be regarded as a revolution in music. All those fantastic scales (scattered through literature) other than the bichromatic to replace Bach's tempered one by a more complex one are condemned both on theoretical and on practical grounds.

CHEMICAL ANALYSIS OF SOME NORTH CAROLINA SCALLOPS

CHARLES E. BELL

University of Florida

A COMPARISON of the chemical composition of scallops was made with that of other protein foods. Scallops were found to contain less protein than beef, lamb, chicken or fish but in mineral constituents scallops excel.

Soaking in fresh water materially increased the size of the scallops but at the same time correspondingly decreased the solids, protein and ash content. Scallops should be washed before being placed on the market. This should be done thoroughly but quickly for if allowed to stand in fresh water more than five minutes they will become soaked.

OUR CALENDAR AND ITS REFORM

CECIL G. PHIPPS
University of Florida

THE DAY, the month and the year are incommensurable periods of time. This is the source of our difficulty with the calendar. The use of a 7-day week is an additional complication.

The Egyptians first found the length of the year, first divided it into 12 months, and first divided the day and the night into 12 hours each. The astrology of Mesopotamia contributed the planetary 7-day week (from the sun, moon and five visible planets) and the Saxons contributed the day names. The Metonic cycle (235 moon months = 19 years approximately) was discovered in 432 B. C. and is the basis of all "moon" calendars.

In 45 B. C., Julius Caesar constructed a "solar" calendar with a leap-year every four years. Soon after this the Roman Senate changed the months to their present lengths and adopted their present names.

Since the fraction of a day in the length of the year is not exactly one quarter of a day, the Roman calendar had become ten days out of step with the seasons by 1582. In that year Pope Gregory XIII dropped the extra ten days and changed the leap-year rule to its present form.

There are two principal plans for reforming the present calendar: (a) 13 months of 28 days each, and (b) 12 months with equal quarters composed of 31-, 30-, 30-day months respectively. Both plans would make the extra day over 52 weeks a second Saturday at the end of December. The second extra day in leap-years would be similarly attached to June. Likewise both would fix the date of Easter. Hence the calendar for every year would be the same.

RAMAN SPECTRA OF WATER SOLUTIONS OF METHANOL, ETHANOL, ACETONE, ACETIC ACID, AND DIOXANE

R. C. WILLIAMSON
University of Florida

RAMAN SPECTRA have been obtained for water solutions of several substances. A series of concentrations was run for each substance with molar ratios of water to the substance in question of 1, 2, 4, 6. The frequency shifts observed all seemed to reach a final value at a concentration of about three moles of water to one of the given substance.

Bond	Methanol		Ethanol		Acetic Acid		Acetone		Dioxane	
	M	ΔM	M	ΔM	M	ΔM	M	ΔM	M	ΔM
C — C			883	— 6	895	— ?	788	+ 6	834	— 3
C — O	1034	— 14	1046	— 6					1107	— 10
C = O					1666	+ 43	1712	— 11		
C — H bending	1462	0	1456	0	1431	0	1430	0	1443	0
C — H stretching	2835	+ 5	2928	+ 6	2942	+ 3	2925	+ 5	2852	+ 13
stretching	2943	+ 7	2974	+ 8					2885	+ 11

In general, it will be noted from the above table that (1) the C—H bending frequencies are not measurably affected; (2) the C—H stretching frequencies all increase, Dioxane showing the greatest shift; (3) Acetone differs from the others in that the C—C frequency increases, while the others decrease. In the case of the C = O vibration, Acetone shows a fairly large decrease, as opposed to a very large increase in the case of Acetic Acid.

AN EXPERIMENT TO DETERMINE THE EFFECT OF SEVERE ATMOSPHERIC DISTURBANCES ON THE OZONE CONTENT OF THE UPPER ATMOSPHERE

W. S. PERRY and R. G. LARRICK

University of Florida

THIS EXPERIMENT has been suggested by Dr. E. O. Hulburt of the Naval Research Laboratory and is being carried on in collaboration with investigators at several stations.

The absorption spectrum of the northern sky is determined each day at noon and the extent of the absorption spectrum is measured from a chosen reference line.

This is plotted against the days in order to determine if there is any variation during a hurricane.

Up to this time the results have been negative.

PHYSIOLOGICAL AND EVOLUTIONARY THEORIES OF NON-ADDITIVE GENE INTERACTIONS

FRED H. HULL

University of Florida

WHEN THE effect of two or more genes acting jointly is not the arithmetic sum of their separate effects, it is said that their interaction is non-additive. Non-additive interaction of genes at the same locus is dominance; non-additive interaction of genes at different loci is epistasy. Theories of Wright and Fisher on physiological and evolutionary aspects of dominance are extended to epistasy, i.e. the monogenic theory is extended to the multigenic case to obtain the foundation of a generalized theory of non-additive gene interactions. Some additions to the general theory are proposed.

THE EFFECTS OF ELASTIC STRETCH ON THE INFRARED SPECTRUM OF RUBBER

RICHARD TASCHEK

University of Florida

THE ABSORPTION spectrum of stretched rubber has been studied in the region between 2μ and 8μ . In the case of unilateral stretch transmission measurements indicate that the absorption bands near 3.3μ and 7μ become broader with increasing stretch while the general background absorption be-

comes more pronounced. Radial stretch was found to produce similar effects in the 3.3μ and 7μ regions while the bands near 6μ became less intense for both unilateral and radial stretch. In the spectrum of rubber stretched radially to approximately 12 times its original area a band was found near 4.8μ where there is no intense absorption in the unstretched material. Since both absorption and reflection are involved in transmission measurements, it was necessary to determine reflection and extinction coefficients. The results indicate that the reflection coefficient diminishes and the extinction coefficient increases with increasing stretch. The observed variations in the extinction coefficients are of greater magnitude than those to be expected from the known density changes which accompany stretching.

A NEW AUTOMATIC RESPIRATION CALORIMETER

W. M. BARROWS, JR.

Florida State College for Women

A FULLY automatic respiration calorimeter has been constructed. It operates upon the following principle:

In addition to heat produced by the animal, electrically generated heat is produced within the calorimeter. A device analogous to the self-balancing Wheatstone bridge maintains the total heat supply (as measured by the heat loss) constant. The electric heat is measured and its amount subtracted from the known total. The difference represents animal heat.

Simultaneously, products of respiration are analyzed and the "indirect" heat computed for comparison.

Experimental results will be given demonstrating the order of accuracy of measurement with this instrument.

The author designed, constructed and operated this instrument during the years 1935-37, in collaboration with Dr. J. R. Murlin, Director of the Department of Vital Economics, University of Rochester.

A SUGGESTED NEW NOTATION FOR LOGARITHMS

HALLETT H. GERMOND

University of Florida

A suggested logarithmic notation of the form $b_N = \log_b N$ would simplify the statements of certain logarithmic relationships. Thus, $\log_b N^r = r \log_b N$ would be written $b_N r = r b_N$. Likewise, the statement $b^{\log_b N} = N$ becomes

simply $b^b N = N$. Other simplifications result.

TWO NEW CRAWFISHES FROM FLORIDA

Cambarus hubbelli

Cambarus acherontis pallidus

HORTON H. HOBBS, JR.

University of Florida

CAMBARUS HUBBELLI was taken from roadside ditches in Holmes, Jackson, and Washington Counties. It is a burrowing species and quite common, especially in the flatwoods of these counties.

Cambarus acherontis pallidus inhabits the caves of Alachua County. It is a subspecies of *C. acherontis* taken from an underground rivulet in Orange County, Florida, near Lake Brantley. *C. acherontis pallidus* has been collected from three caves in Alachua County, namely: Devil's Hole, Warren's Cave and Dudley Cave, and one cave in Columbia County.

THE GENUS HAYLOCKIA

H. HAROLD HUME

University of Florida

UP to this time, the genus *Haylockia*, set up by William Herbert in 1880, has embraced a single species, *H. pusilla*, native in Argentina. It had been described previously as *Sternbergia americana* by Hoffmannseggischen in 1824 and, in 1840, Dietrich referred it to *Zephyranthes*. However, the validity of Herbert's monotypic genus is generally accepted.

In recent years three species of plants, two Peruvian and one Bolivian, have been referred to *Zephyranthes*: *Z. Pseudo-Colchicum* Kranzlin (1914), *Z. parvula* Killip (1926) and *Z. Briquetii* Macbride (1930), that present certain important characteristics at variance with the accepted systematic limitations for the genus *Zephyranthes*. Type material of *Z. Pseudo-Colchicum* in the Museo Berolinensis, of *Z. parvula* in the United States National Herbarium, and of *Z. Briquetii* in the Field Museum of Natural History have been examined critically and the conclusion reached that these three should be transferred to the genus *Haylockia* as *H. Pseudo-Colchicum* (Kranzlin) n. comb., *H. parvula* (Killip) n. comb., and *H. Briquetii* (Macbride) n. comb.

Since the genus *Haylockia* heretofore has been monotypic, the generic description has included only such characters as are presented in the species *H. pusilla*. Because of the proposed additions to the genus, the original generic description of *Haylockia* is extended. Such extension does not affect the basic conception of the genus, nor is it incompatible with a satisfactory systematic placement of the three plants together with the type species in the genus *Haylockia*.

CHARTER OF THE FLORIDA ACADEMY OF SCIENCES

ARTICLE I. NAME. The name of this corporation shall be Florida Academy of Sciences.

ARTICLE II. PURPOSES. The purposes of the Academy shall be to promote scientific research, to stimulate interest in the sciences, to further the diffusion of scientific knowledge, to unify the scientific interests of the state and to issue an annual scientific publication.

ARTICLE III. MEMBERSHIP. Election to membership in the Academy shall be by vote of the Council, upon written nomination by two members.

ARTICLE IV. TERM OF CHARTER. This corporation shall have perpetual existence.

ARTICLE V. OFFICERS. The affairs of the Academy shall be managed by the following officers, to-wit: President, Vice-president, Secretary and Treasurer.

ARTICLE VI. COUNCIL. The officers, together with the immediate past President, and such additional members as are provided in the By-Laws, shall constitute the Council of the Academy.

ARTICLE VII. INITIAL OFFICERS. The names of the officers who shall manage all the affairs of the Academy until the first election under this Charter are as follows:

President—Herman Kurz
Vice-president—R. C. Williamson
Secretary—J. H. Kusner
Treasurer—J. F. W. Pearson

ARTICLE VIII. BY-LAWS. The By-Laws of the Academy shall be made, altered, amended or rescinded at any annual meeting by a two-thirds vote of the members present.

ARTICLE IX. INDEBTEDNESS. The highest amount of indebtedness or liability to which the Academy may at any time subject itself shall never be greater than two-thirds of the value of the property of the Academy.

ARTICLE X. REAL ESTATE. The amount in value of the real estate which the Academy may hold, subject always to the approval of the Circuit Judge, shall be \$100,000.00.

BY-LAWS

(As Amended at the 1937 Annual Meeting)

DIVISION I. MEMBERSHIP

1. The annual dues shall be two dollars for members, one dollar for associate members, payable in advance.
2. Members or associate members whose dues become one year in arrears shall be automatically dropped from membership, after due notice has been given by the Secretary.
3. All persons who become members of the Academy during the year 1936 shall be designated as Charter Members of the Academy.
4. Individuals or institutions may be granted Individual Sustaining Membership or Institutional Sustaining Membership, respectively, on terms to be arranged by the Council in each case.

DIVISION II. SECTIONS

1. There shall be such sections of the Academy as the Council may authorize.
2. All section meetings shall be open to all members, but members shall vote concerning section matters only in those sections in which they are enrolled, and no member shall be enrolled in more than two sections, except by permission of the Council.
3. There shall be a Chairman of each section.
4. The Chairman of each section shall be, *ex-officio*, a member of the Council.

DIVISION III. OFFICERS

1. The President shall discharge the usual duties of a presiding officer at all meetings of the Academy and of the Council, and shall give an address to the Academy at the final meeting of the year for which he is elected.
2. The Vice-President shall assume the duties of the President in the latter's absence.
3. The Secretary shall keep the records of the Academy and of the Council. He shall have charge of the sale and exchange of the Proceedings. Subject to the approval of the Council, he may appoint an Assistant Secretary to assist him in performing his duties.
4. The Treasurer shall have charge of the finances of the Academy.

5. The Council shall exercise general supervision over all the affairs of the Academy in the intervals between meetings of the Academy. Specific duties of the Council shall be:
- a) To be responsible for the publications of the Academy.
 - b) To elect members and associate members.
 - c) To fill vacancies in any of the offices of the Academy.
 - d) To invest the funds of the Academy.
 - e) To make recommendations to the Academy in matters pertaining to general policy.
 - f) To appoint a nominating committee.
 - g) To appoint an auditing committee.
 - h) To appoint an Editor, an editorial committee, and a Business Manager of the Proceedings.
 - i) To determine affiliation relations of the Academy.
 - j) To choose the time and place of meetings of the Academy.
 - k) To prepare programs for the meetings of the Academy.
 - l) To authorize the formation of Sections of the Academy.
 - m) To approve the appointment of the Assistant Secretary.

DIVISION IV. ELECTIONS

1. The officers and section chairmen of the Academy shall be elected at the last session of the annual meeting.
2. The Council shall appoint a nominating committee which shall nominate a candidate for each office named in Section 1, but additional nominations may be made by any member.
3. Officers shall be elected by vote of the members present at the annual meeting.
4. Section chairmen shall be elected by vote of the members enrolled in their respective sections and present at the annual meeting.
5. A plurality of the votes cast for each office shall constitute election.
6. The officers thus elected shall enter upon their duties at the adjournment of the annual meeting.
7. Vacancies which occur in any office or committee chairmanship between annual meetings shall be filled by the Council.

DIVISION V. PUBLICATIONS

1. There shall be published an annual volume to be called the *Proceedings of the Florida Academy of Sciences*.
2. The Proceedings shall be under the immediate control of the Council, through an Editor, an Editorial Committee, of which the Editor shall be Chairman *ex officio*, and a Business Manager, all of whom shall be chosen by the Council annually.
3. One copy of the Proceedings shall be supplied free to each paid up member and associate member.

DIVISION VI. FINANCIAL MATTERS

1. The fiscal year of the Academy shall be the calendar year, and the accounts of the Treasurer shall be balanced January 1 of each year.
2. Prior to each annual meeting the Council shall select an auditing committee of two members which shall inspect the financial records of the Academy and report on them to the annual meeting.
3. All orders which involve payment of the funds of the Academy shall be signed by the President and the Secretary.

DIVISION VII. AFFILIATIONS

1. Affiliation relations between the Academy and other organizations may be arranged by the Council on such terms as it may decide in each case, subject to the approval of the annual meeting.

DIVISION VIII. MEETINGS

1. There shall be at least one meeting of the Academy annually.
2. The time and place of meetings shall be determined by the Council.
3. Meetings shall be conducted under Robert's Rules of Order.
4. At least thirty days written notice of each annual meeting shall be given.
5. The Council shall be the program committee for the general sessions at any meeting. The Secretary together with the Chairman of each section shall constitute the program committee for that section.
6. At any meeting of the Academy of which thirty days notice has been given, those present shall constitute a quorum; at other meetings, one-fourth of the members.

DIVISION IX. AMENDMENTS (as provided in Charter)

1. By-laws may be made, altered, amended or rescinded at any annual meeting by a two-thirds vote of the members present.

OFFICERS FOR 1937

President—H. Harold Hume, University of Florida, Gainesville.
Vice-president—Jennie Tilt, Florida State College for Women, Tallahassee
Secretary—J. H. Kusner, University of Florida, Gainesville
Treasurer—J. F. W. Pearson, University of Miami, Coral Gables
Chairman of the Biological Sciences Section—Edward P. St. John, Florid City
Chairman of the Physical Sciences Section—J. E. Spurr, Rollins College,
 Winter Park
Editor of the Proceedings—T. H. Hubbell, University of Florida, Gainesville
Business Manager of the Proceedings—R. S. Johnson, University of Florida,
 Gainesville

OFFICERS FOR 1938

President—R. I. Allen, Stetson University, DeLand
Vice-president—Charlotte B. Buckland, Landon High School, Jacksonville
Secretary—J. H. Kusner, University of Florida, Gainesville
Assistant Secretary—C. I. Mosier, University of Florida, Gainesville
Treasurer—(until March 21)—J. F. W. Pearson, University of Miami, Coral
 Gables
Acting Treasurer—(after March 21)—E. M. Miller, University of Miami,
 Coral Gables
Chairman of the Biological Sciences Section—L. Y. Dyrenforth, St. Lukes
 Hospital, Jacksonville
Chairman of the Physical Sciences Section—B. P. Reinsch, Florida Southern
 College, Lakeland
Chairman of the Social Sciences Section—R. S. Atwood, University of Florida,
 Gainesville
Editor of the Proceedings—H. Harold Hume, University of Florida, Gaines-
 ville
Business Manager of the Proceedings—R. S. Johnson, University of Florida,
 Gainesville

LIST OF MEMBERS—1937

†Adams, R. H., Miami Senior High School, Miami (Biology)

*Albee, Fred H., Venice (Medicine)

Allen, E. Ross, Florida Reptile Institute, Silver Springs (Herpetology)

*Allen, R. I., Stetson University, DeLand (Physics)

*Charter Member

†Associate Member

- *Anderson, W. S., Rollins College, Winter Park (Chemistry)
 *Armstrong, J. D., Box 70, Route 1, South Jacksonville (Chemistry, Physics)
 *Arnold, Lillian E., Experiment Station, University of Florida, Gainesville (Botany)
 *Atwood, R. S., University of Florida, Gainesville (Geography)
 Babcock, Louis, M. & T. Building, Buffalo, New York (Ichthyology)
 *Bacon, Milton E., Jr., 2008 Riverside Drive, Jacksonville (Archeology, Geology)
 *Bahrt, G. M., P. O. Box 629, U.S.D.A. Laboratory, Orlando (Chemistry, Soils)
 Baker, Harry Lee, State Forester, Tallahassee (Forestry)
 *Barbour, R. B., 656 Interlachen Avenue, Winter Park (Chemistry)
 *Barnette, R. M., Experiment Station, University of Florida, Gainesville (Chemistry) [Deceased]
 Barrows, W. M., Florida State College for Women, Tallahassee (Physics)
 *Bass, J. F., Jr., Bass Biological Laboratory, Englewood (Marine Biology)
 Beach, Richard H., Mainland High School, Daytona Beach (Biology)
 *Beardslee, H. C., Altamonte Springs (Mycology)
 *Becker, R. B., Experiment Station, University of Florida, Gainesville (Agriculture)
 *Becknell, G. G., University of Tampa, Tampa (Physics, Mathematics)
 *Bellamy, R. F., Florida State College for Women, Tallahassee (Sociology)
 *Bell, C. E., Experiment Station, University of Florida, Gainesville (Chemistry, Soils)
 *Berger, E. W., Experiment Station, University of Florida, Gainesville (Entomology)
 Berner, Lewis, University of Florida, Gainesville (Biology)
 *Blackmon, G. H., Experiment Station, University of Florida, Gainesville (Horticulture)
 Blair, W. Frank, Laboratory of Vertebrate Genetics, University of Michigan, Ann Arbor, Michigan (Biology)
 *Bless, Arthur A., University of Florida, Gainesville (Physics)
 *Bly, R. S., Florida Southern College, Lakeland (Chemistry)
 *Boliek, M. Irene, Florida State College for Women, Tallahassee (Zoology)
 *Boyd, M. F., P. O. Box 793, Tallahassee (Epidemiology)
 *Brown, C. A., 3408 Lowell Street, N. W., Washington, D. C. (Chemistry, Agriculture)
 *Bruce, Malcolm, 325 Arlington Street, Gainesville (General)
 *Bryan, O. C., Box 209, Bartow (Agronomy)
 *Buckland, Charlotte B., Landon High School, Jacksonville (Biology)
 *Buswell, Walter M., University of Miami, Coral Gables (Botany)
 *Byers, C. F., University of Florida, Gainesville (Biology)
 *Camp, A. F., Citrus Experiment Station, Lake Alfred (Horticulture)
 *Camp, J. P., Experiment Station, University of Florida, Gainesville (Agronomy)
 *Campbell, Nelle, Stetson University, DeLand (Zoology)
 †Carlin, Kathryn L., 248 Rivo Alto Island, Miami Beach (Chemistry)
 *Carr, A. F., Jr., University of Florida, Gainesville (Biology)
 †Carr, Mrs. A. F., Jr., 440 Colson St., Gainesville (Biology)
 *Carr, T. D., 1828 W. Church Street, Gainesville (Physics)
 *Carver, W. A., Experiment Station, University of Florida, Gainesville (Agronomy)
 *Cason, T. Z., 2033 Riverside Avenue, Jacksonville (Medicine)
 *Chandler, H. W., University of Florida, Gainesville (Mathematics)
 *Christensen, B. V., University of Florida, Gainesville (Pharmacy)
 Clawson, Mrs. E. Richey, Ponce de Leon High School, Coral Gables (Chemistry, Physics)

*Charter Member

†Associate Member

- *Clouse, J. H., University of Miami, Coral Gables (Physics)
 *Conn, John F., Stetson University, DeLand (Chemistry)
 *Connor, Ruth, Florida State College for Women, Tallahassee (Home Economics)
 *Conradi, Edward, Florida State College for Women, Tallahassee (Psychology)
 *Dauer, Manning J., University of Florida, Gainesville (History, Political Science)
 †Davis, Barbara J., Apopka (Mathematics, Physics)
 *Davis, E. M., Rollins College, Winter Park (Ornithology, Entomology)
 †Davis, Katherine, P. O. Box 402, Homestead (Psychology, Botany)
 Davis, Norman W., Red Hill Road, Rockland County, New City, New York (Biology)
 *Davis, U. P., University of Florida, Gainesville (Mathematics)
 Dell, Mrs. R. G., 1006 Kennedy Avenue, Duquesne, Pa. (Zoology)
 *DeMelt, W. E., Florida Southern College, Lakeland (Psychology)
 *Deviney, Ezda, Florida State College for Women, Tallahassee (Zoology)
 Diddell, Mrs. W. D., 333 East 7th Street, Jacksonville (Botany)
 *Disher, Dorothy R., Florida State College for Women, Tallahassee (Psychology)
 *Dostal, B. F., University of Florida, Gainesville (Mathematics)
 *Doyle, S. R., Florida State College for Women, Tallahassee (Biology)
 *Dyrenforth, L. Y., 1022 Park Street, Jacksonville (Pathology)
 Eddins, A. H., Agricultural Experiment Station Laboratory, Hastings (Plant Pathology)
 *Erck, G. H., Weirsdale (Agriculture)
 Eyman, Ralph L., Florida State College for Women, Tallahassee (Education)
 *Fairchild, David, 4013 Douglas Road, Coconut Grove (Botany)
 *Fargo, W. G., P. O. Box 874, Pass-a-Grille Beach (Ornithology)
 *Faulkner, Donald, Stetson University, DeLand (Mathematics)
 *Faust, Burton, 436 N. E. 94th Street, Miami (Physics and Mathematics)
 *Fernald, H. T., 707 East Concord Avenue, Orlando (Entomology)
 *Fifield, W. M., Experiment Station, University of Florida, Gainesville (Horticulture)
 *Finner, Paul F., Florida State College for Women, Tallahassee (Psychology)
 *Floyd, B. F., Davenport (Horticulture)
 *Floyd, W. L., University of Florida, Gainesville (Agriculture)
 *Foote, P. A., University of Florida, Gainesville (Pharmacy)
 *French, R. B., Experiment Station, University of Florida, Gainesville (Chemistry)
 †Fuller, Dorothy L., Stetson University, DeLand (Biology)
 *Gaddum, L. W., Experiment Station, University of Florida, Gainesville (Biochemistry)
 *Gautier, T. N., University of Florida, Gainesville (Physics)
 *George, C. R., Jr., 1514 Barnette National Bank, Jacksonville (Archeology)
 *Germond, H. H., University of Florida, Gainesville (Mathematics)
 *Gifford, J. C., University of Miami, Coral Gables (Forestry)
 *Giovannoli, Leonard, Key West Aquarium, Key West (Ichthyology)
 *Gist, N. N., Box 7, McIntosh (Agriculture)
 *Goff, C. C., Leesburg Experiment Station Laboratory, Leesburg (Plant Pathology)
 *Goin, Coleman, University of Florida, Gainesville (Biology)
 Gordon, Donald P., 1852 S. W. Second Avenue, Miami (Biology)
 *Graham, Viola, Florida State College for Women, Tallahassee (Physiology)
 *Greene, E. Peck, P. O. Box 42, Tallahassee (Chemistry)

*Charter Member

†Associate Member

- *Gunter, Herman, State Geologist, Tallahassee (Geology)
 *Gut, H. James, P. O. Box 700, Sanford (Paleontology)
 *Hadley, A. H., 136 Arlington Way, Ormond Beach (Ornithology)
 †Hardin, Lily, Miami Senior High School, Miami (General)
 *Harrison, R. W., 2337 N. W. Flagler Terrace, Miami
 *Hawkins, J. E., University of Florida, Gainesville (Chemistry)
 *Heinlein, C. P., Florida State College for Women, Tallahassee (Psychology)
 *Heinlein, Julia H., Florida State College for Women, Tallahassee (Psychology)
 *Hinckley, E. D., University of Florida, Gainesville (Psychology)
 Hjort, E. V., University of Miami, Coral Gables (Chemistry)
 *Hobbs, H. H., University of Florida, Gainesville (Biology)
 *Hodges, Quinton E., Hinesville, Georgia (Physics)
 *Hodsdon, L. A., N. W. N. River Drive, Miami
 *Hubbell, T. H., University of Florida, Gainesville (Biology)
 Hughes, Ray C., University of Florida, Gainesville (Chemistry, Physics)
 *Hull, Fred H., Experiment Station, University of Florida, Gainesville (Genetics)
 *Hume, H. H., Experiment Station, University of Florida, Gainesville (Botany)
 Johnson, Margaret C., Box 1094, Punta Gorda (Biology)
 *Johnson, R. S., University of Florida, Gainesville (General)
 *Kallman, I. E., P. O. Box 2747, Gainesville (General)
 *Keenan, Edward T., Frostproof (Soil Chemistry)
 *Kelly, Howard A., 1406 Eutaw Place, Baltimore, Maryland (Medicine)
 *Kime, C. D., Box 222, Orlando (Agriculture)
 *Kincaid, R. R., North Florida Experiment Station, Quincy (Plant Pathology)
 Kindred, J. J., Astoria, Long Island, New York City [Deceased]
 *Kinser, B. M., Eustis (General)
 *Kirk, W. G., Experiment Station, University of Florida, Gainesville (Animal Husbandry and Chemistry)
 *Knowles, H. L., University of Florida, Gainesville (Physics)
 Kramer, C. W., 2328 S. W. 17th Street, Miami (Plant Physiology)
 *Kurz, Herman, Florida State College for Women, Tallahassee (Botany)
 *Kusner, J. H., University of Florida, Gainesville (Mathematics, Astronomy)
 *Larson, Olga, Florida State College for Women, Tallahassee (Mathematics)
 *Leigh, Townes R., University of Florida, Gainesville (Chemistry)
 *Lewis, Leland J., Florida State College for Women, Tallahassee (Chemistry)
 †Linson, Elizabeth S., 131 W. University Avenue, DeLand (Chemistry, Mathematics)
 *Longstreet, Rupert J., 610 Braddock Avenue, Daytona Beach (Psychology, Ornithology)
 *Loucks, K. W., Experiment Station, Leesburg (Plant Pathology)
 †Lyle, Lilla, Miami Beach Senior High School, Miami Beach (Mathematics)
 *Lynn, Elizabeth, Florida State College for Women, Tallahassee (Physics)
 McAllister, Birdie, Miami Beach High School, Miami Beach, (Taxonomy, Ecology)
 *McClanahan, R. C., U. S. Biological Survey, Washington, D. C. (Biology)
 †McGinty, Paul, Boynton (Zoology)
 †McGinty, Thomas L., Boynton (Zoology)
 *MacGowan, W. Leroy, 3212 Park Street, Jacksonville (Biology)
 *McKinnell, Isabel, Florida State College for Women, Tallahassee (Chemistry)
 *Mahorner, Sue A., 865 Oak Street, Jacksonville (Psychology)
 *Marshall, J. J., 918 Seybold Building, Miami (Astronomy)
 *Martin, J. M., 1828 W. Church Street, Gainesville (Histology)
 *Mathews, E. L., Plymouth (Horticulture)

*Charter Member

†Associate Member

- Mendenhall, H. D., Florida State College for Women, Tallahassee (Engineering)
- Merrill, G. B., State Plant Board, Gainesville (Entomology)
- *Meyer, Max F., University of Miami, Coral Gables (Psychology)
- †Miller, Dorothy B., University of Miami, Coral Gables (Zoology)
- *Miller, E. Morton, University of Miami, Coral Gables (Zoology)
- Montgomery, J. H., State Plant Board, Gainesville (Entomology)
- *Moore, Coyle E., Florida State College for Women, Tallahassee (Sociology)
- *Moore, F. Clifton, Florida State College for Women, Tallahassee (Medicine)
- *Mosier, Charles L., University of Florida, Gainesville (Psychology)
- *Mowry, Harold, Experiment Station, University of Florida, Gainesville (Horticulture)
- Murray, Mary R., Robert E. Lee Junior High School, Miami (General)
- *Neal, W. M., Experiment Station, University of Florida, Gainesville (Animal Husbandry)
- Newell, Wilmon, University of Florida, Gainesville (Agriculture)
- *Newins, H. S., University of Florida, Gainesville (Forestry)
- Norfleet, Sara C., Bradenton (Chemistry)
- †Ogilvie, Frances May, Stetson University, DeLand
- *Osborn, Herbert, Rollins College, Winter Park (Zoology, Entomology)
- Owen, B. Jay, Box 1111, Tallahassee (Chemistry)
- Palmer, Katharine B., 135 N. W. 60th Street, Miami (Biology)
- Palmer, P. S., 135 N. W. 60th Street, Miami (Chemistry, Physics, Astronomy)
- *Parker, Horatio Newton, 2777 Park Street, Jacksonville (Public Health)
- *Parsons, Rhey Boyd, Florida State College for Women, Tallahassee (Education)
- *Partridge, Sarah W., 508 S. Duval Street, Tallahassee (Biology)
- *Pearson, Hazel M., University of Miami, Coral Gables (Ecology)
- *Pearson, J. F. W., University of Miami, Coral Gables (Zoology)
- Perry, Louise M., Sanibel (Marine Biology, Ornithology)
- *Perry, W. S., University of Florida, Gainesville (Physics)
- *Pfluge, Margaret, 315 W. Park Street, Tallahassee (Biology)
- *Phillips, Walter S., University of Miami, Coral Gables (Botany)
- *Phipps, Cecil G., University of Florida, Gainesville (Mathematics)
- *Pierce, E. Lowe, Jr., 417 Elizabeth Street, Key West (Biology)
- *Ponton, G. M., Florida State Road Department, Tallahassee (Geology)
- †Poole, Eva L., 748 N. W. 39th Street, Miami (Biology)
- *Raa, Ida, Leon High School, Tallahassee (Chemistry)
- *Reinsch, B. P., Florida Southern College, Lakeland (Mathematics, Physics)
- *Reitz, J. Wayne, University of Florida, Gainesville (Agricultural Economics)
- *Richards, Harold F., Florida State College for Women, Tallahassee (Physics)
- *Ritchey, George E., Experiment Station, University of Florida, Gainesville (Agronomy)
- *Robinson, T. Ralph, P. O. Box 1058, Orlando
- *Rogers, J. Speed, University of Florida, Gainesville (Biology)
- *Rogers, L. H., Experiment Station, University of Florida, Gainesville (Chemistry)
- *Rofls, C., 509 E. Church Street, Gainesville (Botany)
- *Rofls, P. H., 509 E. Church Street, Gainesville (Botany)
- *Ruehle, George D., Experiment Station, Homestead (Plant Pathology)
- *Rusoff, L. L., University of Florida, Gainesville (Biochemistry)
- *Sadler, G. G., 315 N. Highland Street, Mount Dora (Zoology)
- *Sandels, Margaret R., Florida State College for Women, Tallahassee (Home Economics)

*Charter Member

†Associate Member

- †Schell, Hannah, 220 2nd Street, N. E., Winter Haven (Biology, Chemistry)
 *Schornherst, Ruth, Florida State College for Women, Tallahassee (Botany)
 *Scott, George G., 1394 Grove Terrace, Winter Park (Biology)
 *Senn, P. H., University of Florida, Gainesville (Agronomy)
 *Shealy, A. L., University of Florida, Gainesville (Animal Husbandry)
 *Sherman, H. B., University of Florida, Gainesville (Biology)
 *Shippey, W. B., Experiment Station, Sanford (Plant Pathology)
 *Shor, Bernice C., Rollins College, Winter Park (Biology)
 *Sieplein, O. J., P. O. Box 212, Coral Gables (Chemistry)
 *Simpson, J. Clarence, 114 S. Plant Avenue, Tampa (Archeology)
 Sims, Harris G., Florida Southern College, Lakeland (General)
 Singleton, Gray, Federal Land Bank, Columbia, South Carolina
 (Horticulture)
 *Smith, Cornelia M., Stetson University, DeLand (Biology)
 *Smith, Frank, 875 Marine Court South, St. Petersburg (Zoology)
 Smith, Maxwell, Lantana (Biology)
 *Smith, Richard M., P. O. Box 212, Tallahassee (Chemistry)
 *Springer, J. Stuart, Bass Biological Laboratory, Englewood (Zoology)
 *Spurr, J. E., Rollins College, Winter Park (Geology)
 *St. John, Robert P., Floral City (Botany)
 *Stevens, H. E., 224 Annie Street, Orlando (Horticulture)
 *Stewart, Alban, Florida State College for Women, Tallahassee (Botany,
 Bacteriology)
 *Stiles, C. Wardell, Rollins College, Winter Park (Zoology)
 *Stokes, W. E., Experiment Station, University of Florida, Gainesville
 (Agronomy)
 *Story, Helen F., 2762 Burlington Avenue, St. Petersburg (Astronomy,
 Mathematics)
 *Stubbs, Sidney A., State Museum, University of Florida, Gainesville
 (Geology)
 *Swanson, D. C., University of Florida, Gainesville (Physics)
 Tallant, W. M., Bradenton (Archeology)
 *Tanner, W. Lee, 732 N. W. 36th Street, Miami (Chemistry)
 †Taschek, Richard, University of Florida, Gainesville (Physics)
 †Terry, Myrtelle H., Box 665, Miami
 *Thomas, R. H., 37 S. Hogan Street, Jacksonville (Electricity)
 *Tilt, Jennie, Florida State College for Women, Tallahassee (Chemistry)
 *Tisdale, W. B., Experiment Station, University of Florida, Gainesville
 (Plant Pathology)
 *Tissot, A. N., Experiment Station, University of Florida, Gainesville
 (Entomology)
 *Tracy, Anna M., Florida State College for Women, Tallahassee (Nutrition)
 *Vance, Charles B., Stetson University, DeLand (Geology)
 *Van Cleef, Alice, Glenwood (Chemistry and Biology)
 *Van Leer, B. R., North Carolina State College, Raleigh, N. C. (Engineering)
 *Vermillion, Gertrude, Florida State College for Women, Tallahassee
 (Chemistry)
 *Waddington, Guy, Rollins College, Winter Park (Chemistry)
 *Walker, Marion N., Experiment Station, Leesburg (Plant Pathology)
 *Wallace, Howard K., University of Florida, Gainesville (Biology)
 *Waskom, Hugh L., Florida State College for Women, Tallahassee
 (Psychology)
 *Weber, George F., Experiment Station, Gainesville (Plant Pathology)
 *Weil, Joseph, University of Florida, Gainesville (Engineering)
 *Weinberg, E. F., Rollins College, Winter Park (Mathematics)
 *West, Erdman, University of Florida, Gainesville (Botany)

*Charter Member

†Associate Member

- *West, Frances L., St. Petersburg Junior College, St. Petersburg (Biology)
- †West, Henry S., University of Miami, Coral Gables (Psychology)
- *White, Sarah P., Florida State College for Women, Tallahassee (Medicine)
- *Williams, F. Dudley, University of Florida, Gainesville (Physics)
- *Williams, Henry W., Drawer C., Umatilla (Herpetology)
- *Williams, Osborne, University of Florida, Gainesville (Psychology)
- *Williamson, R. C., University of Florida, Gainesville (Physics)
- *Willoughby, C. H., University of Florida, Gainesville (Animal Husbandry)
- *Wise, Louis E., Rollins College, Winter Park (Chemistry)
- *Wray, F. L., 1927 Hollywood Blvd., Hollywood
- Yothers, W. W., 457 Boone Street, Orlando
- *Young, John W., 720 Glen Ridge Drive, West Palm Beach (Mathematics, Physics)
- Young, Frank N., University of Florida, Gainesville (Biology)
- *Young, T. Roy, Jr., University of Florida, Gainesville (Entomology)

*Charter Member

†Associate Member

506.73
.F6 F63

PROCEEDINGS

of the

Florida Academy

of

Sciences

for

1938

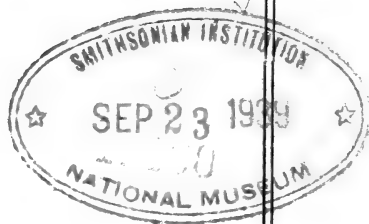

VOL. 3

Published by the Academy

Gainesville, Florida

June, 1939

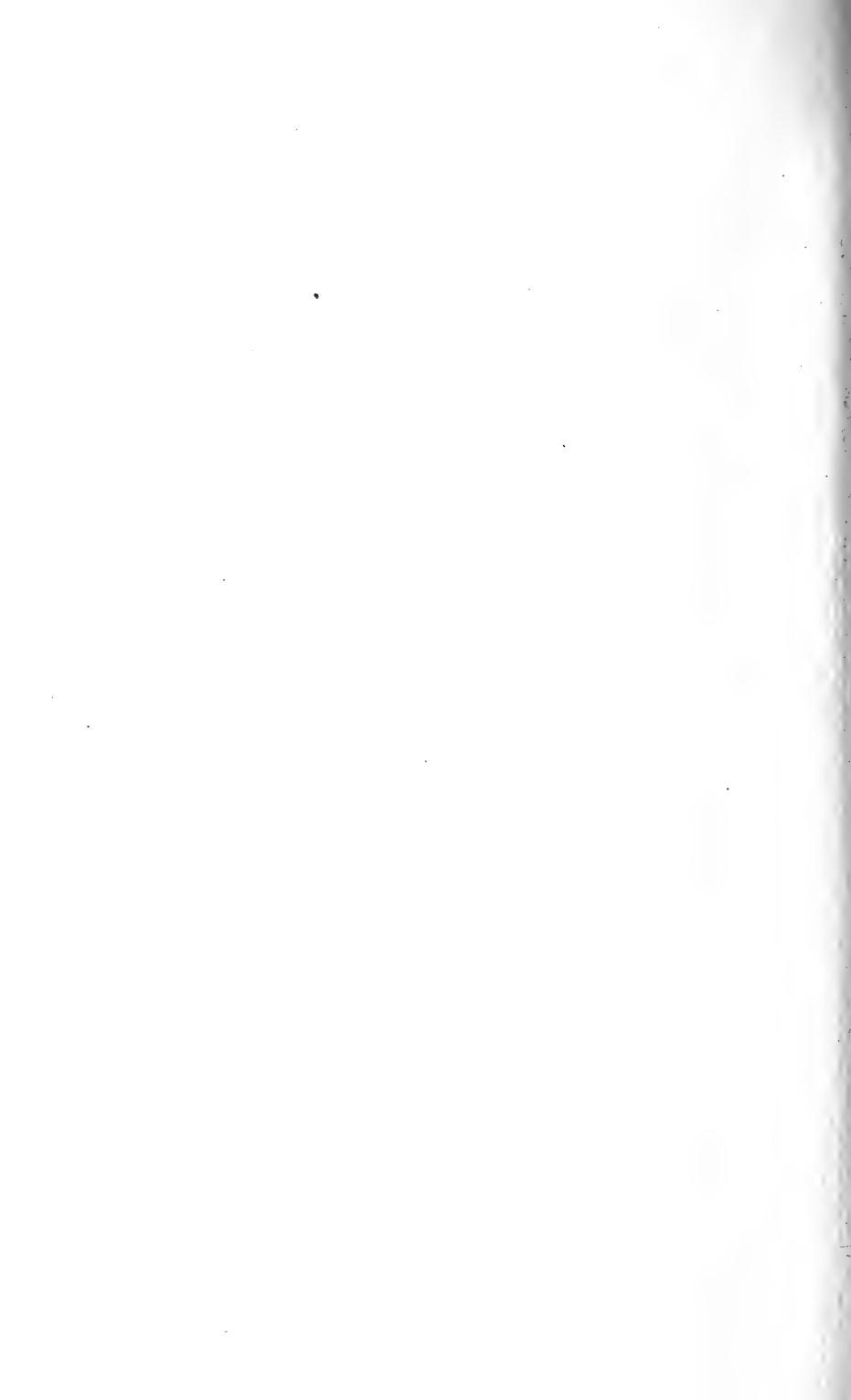

PROCEEDINGS

of the

Florida Academy

of

Sciences

for

1938

VOL. 3

Published by the Academy

Gainesville, Florida

June, 1939

PROCEEDINGS OF THE FLORIDA ACADEMY OF SCIENCES

Published annually by the Academy

Editor: L. Y. Dyrenforth
Managing Editor: J. H. Kusner
Editorial Committee: A. F. Carr
Ezda Deviney
C. I. Mosier
Maurice Mulvania
S. A. Stubbs
R. C. Williamson

A paper-bound copy of the *Proceedings* is sent to each member of the Academy, without charge. A cloth-bound copy may be obtained, instead, upon payment of \$1.00.

The sale price of the *Proceedings* is:

Paper-bound—\$1.00 per copy
Cloth-bound—\$2.00 per copy

The Academy will be pleased to enter into exchange arrangements with other scientific societies in any field and in any country.

Orders for copies of the *Proceedings*, subscriptions, exchange publications, inquiries concerning exchange, and general correspondence concerning Academy matters should be addressed to:

J. H. KUSNER, *Secretary*
Florida Academy of Sciences
University of Florida
Gainesville, Fla.

CONTENTS

1938 ANNUAL MEETING

Page

Secretary's Report.—J. H. KUSNER	1
Report of the Acting Treasurer.—E. MORTON MILLER	3
Program of the Third Annual Meeting	4
Committees for the Third Annual Meeting	7
Changes in the By-Laws	8
The Achievement Medal	8
Research Grant	8

PAPERS

Notes on the Sharks of Florida.—STEWART SPRINGER	9
Variations Within Successive Categories of an Extended Series of Extra-Sensory Discriminations.—ELIZABETH A. BECKNELL	42
Hitherto Unrecorded Vertebrate Fossil Localities in South-Central Florida.—H. JAMES GUT	50
Additions to the Recorded Pleistocene Mammals from Ocala, Florida.—H. JAMES GUT	54
The Role of Hormones in the Development of Higher Plants.—WILLIAM C. COOPER	56
<i>Torreya</i> West of the Apalachicola River.—HERMAN KURZ	66
A Physiographic Study of the Tree Associations of the Apalachicola River.—HERMAN KURZ	78
Pretended Accuracies in Computations.—B. P. REINSCH	91
The Necessity for Artesian Water Conservation in the Florida Peninsula.—SIDNEY A. STUBBS	97
Notes on Florida Water Snakes.—E. ROSS ALLEN	101
Notes on the Feeding and Egg-Laying Habits of the <i>Pseudemys</i> .—E. ROSS ALLEN	105
A Preliminary Report on Studies of Moss Habitats and Distribution in North Central Florida.—RUTH SCHORNHERST	109
Are Women Clairvoyant?—JULIA H. HEINLEIN and CHRISTIAN P. HEINLEIN	115
Ovulation Time in Primates.—JAMES H. ELDER	125
<i>Holothurians</i> from Biscayne Bay, Florida.—ELISABETH DEICHMANN	128

ABSTRACTS

Notes on the Histology of <i>Siren</i> .—G. G. SCOTT	139
The Experimental Techniques of Scientific Psychology versus the Speculative Dogmas of Educational Psychosophy.—CHRISTIAN P. HEINLEIN	139
Resonance in the Telephone and in the Cochlea.—MAX F. MEYER	140
The Basal Metabolism of College Women as Influenced by Race and Degree of Activity.—LOLA SCHMIDT and JENNIE TILT	141
Suggestions Concerning the Teaching of Biology.—G. G. SCOTT	142
Mental Hygiene in Secondary Education.—W. L. MACGOWAN	143
Psychometric Results and Notes on Behavior Before and After a Prefrontal Lobotomy on a Mental Patient.—PHILIP WORCHEL	144
Conditions for Algebraic Solutions of Certain Ordinary Differential Equations of First Order and First Degree.—BARBARA DAVIS	145
The S-H Frequency of the Mercaptans.—DUDLEY WILLIAMS	145
Suggestions for an Improved Notation in Trigonometry.—H. H. GERMOND	145
The Neutron.—D. C. SWANSON	146
An Infra-Red Study of Several Liquid Crystals.—RICHARD TASCHEK and DUDLEY WILLIAMS	147
The Design of Numerical Problems for Instructional Efficiency.—H. H. GERMOND	147
Semantic Analysis: A Basic Step in Scientific Method.—CHRISTIAN P. HEINLEIN	147
A New Concept of Florida Soils.—EDWARD T. KEENAN	148
Natural Phenomena.—MARY W. DIDDELL	148

ACADEMY PERSONNEL

Officers of the Academy for 1938	150
Officers of the Academy for 1939	150
List of Members—1938	151
Institutional Sustaining Members	157

PROCEEDINGS OF THE FLORIDA ACADEMY OF SCIENCES

VOLUME 3

1938

SECRETARY'S REPORT

During 1938 the membership of the Academy has continued to grow. When the Academy was founded in February 1936, the application for the Charter contained ninety-two signatures. By the end of 1936 the membership had grown to 236, and at the Annual Meeting of 1937 the membership totaled 262. Today the Academy has 285 members in good standing. This is, of course, exclusive of the memberships which have lapsed for non-payment of dues. Our members are to be found in every part of the state, in every Florida college and university, in 16 high schools and in many government laboratories and other organizations of a scientific nature, both within the state and elsewhere. Although this growth in membership could hardly be called phenomenal, it is gratifying that we are getting new members more rapidly than we are losing old ones.

Although we are hardly interested in the mere size of the membership roll of the Academy, we undoubtedly do desire to have associated with us all those in the state who share our purposes and who are worthy of membership in this science-wide and state-wide scientific society which is, for Florida, the official counterpart of the American Association for the Advancement of Science, with which the Academy is affiliated.

There are undoubtedly many persons who would like to take part in the activities of the Academy and whom we would desire to have associated with us. The searching out of these people and drawing them into membership in the Academy is a responsibility which should be shared by all members. It is to be hoped that every member who knows of others who are worthy of and would be interested in membership in the Academy will nominate such persons for membership.

At the 1937 Annual Meeting, the By-Laws were amended to provide for sustaining membership, both individual and institutional.

As a result of this action, the following six institutions have become institutional sustaining members of the Academy:

University of Florida
 Florida State College For Women
 University of Miami
 Rollins College
 Florida Southern College
 Stetson University

Incidentally, these six colleges and universities pay a total of \$290 per year as their institutional membership dues.

It is to be hoped that such of our members as are connected with institutions or organizations not yet contained in this list, will put forth efforts to add their institutions to this distinguished roll. The Secretary will be glad to consult with any members in the matter of initiation of such moves.

The Academy has not been quite so fortunate in building up its roll of individual sustaining members. The list of such members is as yet extremely meager, and it is to be hoped that many more of those members who are in a position to do so will undertake this slightly increased responsibility of supporting the work of the Academy. Transfer to Individual Sustaining Membership is open to all regular members automatically upon payment of the small additional sum of \$3 which, incidentally, carries with it a cloth-bound copy of the *Proceedings* instead of the usual paper-bound copy. Many of us are hopeful that the list of individual sustaining members will undergo considerable growth.

Acting on instructions from the Council, the Secretary's office has made some progress in bring about exchange arrangements with other scientific societies. Our *Proceedings* is now being exchanged with periodicals published by most of the academies and many other scientific societies. It is expected soon to issue to all members a list of the publications in the possession of the Academy so that these may be available for their use, upon request.

The reception given to the first volume of our *Proceedings* has been very gratifying. Unsolicited orders, requests for copies, or offers of exchange have been received from places as remote as Great Britain, Germany, and even China.

During the year, the Council of the Academy has had two meetings apart from the Annual Meeting. One of these was held in Gainesville and the other in DeLand. Of course, the bulk of the Council business was conducted by correspondence, to which the

members of the Council of this year have paid serious and prompt attention.

A considerable part of the work of the Secretary's office has been carried on through the cooperation of the University of Florida which has provided clerical and stenographic assistance and many other aids. During the past year, the work of the Secretary's office has been aided through the efforts of Dr. C. I. Mosier of the University of Florida who has occupied the post of assistant secretary created at the 1937 Annual Meeting. Also, many other colleagues have at various times during the year allowed themselves to be impressed into the Academy's service.

The Secretary can truthfully report that the proportion of its membership which has a strong interest in and loyalty to the Academy is sufficiently large to augur well for the Academy's future development.

November 18, 1938

J. H. KUSNER, *Secretary*

REPORT OF THE ACTING TREASURER

(As of November 15, 1938)

INCOME:

Balance carried forward from November 20, 1937	\$734.39
Dues received: 1937 Memberships	116.00
1938 Memberships	309.10
1939 Memberships	14.00
1937 Associate Memberships	6.00
1938 Associate Memberships	5.00
1939 Associate Memberships	1.00
1938 Institutional Sustaining Memberships	165.00
Receipts from the sale of Proceedings, Vol. 1	29.00
A. A. A. S. Research Grant	50.00

\$1,429.49

DISBURSEMENTS:

Publishing of Proceedings, Vol. 1	\$890.79
Maps—drawings for Proceedings	8.00
Administrative Expenses:	
Secretary's Office, Postage and stationery	65.47
Express and freight	41.78
Treasurer, Postage and envelopes	9.56
Business Manager, Express, telegrams, reprint covers	14.85
Publishing of Programs, 1937 Meetings	25.50
Research Grant, 1938	50.00
Miscellaneous: Book adjustments, reassignments of dues	4.00

Total Disbursements on order of

President and Secretary

\$1,109.95

Balance, actual cash available

319.54

ACCOUNTS RECEIVABLE:

1938 Institutional Sustaining Memberships	\$100.00
1937 Univ. of Florida, Purchase of Proceedings	100.00
1938 Memberships yet unpaid (approx.)	180.00
Reimbursements by authors for engravings in Proceedings, 1	58.00
	\$ 438.00

• E. MORTON MILLER, *Acting Treasurer.*

PROGRAM OF THE THIRD ANNUAL MEETING—ROLLINS COLLEGE

FIELD TRIPS ON THURSDAY AFTERNOON, NOVEMBER 17, 1938

1. Two hour boat trip on Winter Park lakes.
2. Wekiwa Springs and Nature's Mystery.
3. Trip to Gentile Brothers' Packing House, Winter Park.
4. Inspection of Orlando Municipal Airport.

FRIDAY, NOVEMBER 18, 1938

9:30 to 11:10 A. M.—GENERAL SESSION—Annie Russell Theater
President R. I. Allen presiding

PRESENTATION OF PAPERS

1. Natural Phenomena—Mrs. W. D. Diddell, Jacksonville. 15 min.
2. The Austin Cary Memorial Demonstration Forest—H. S. Newins, University of Florida. 5 min.
3. The Vitamin C Content of Grapefruit—R. W. Harrison, Miami. 10 min.
4. A Report on the Water Snakes (*Natrix*) of Florida—E. Ross Allen, Florida Reptile Institute, Silver Springs. 12 min.
5. A Preliminary Report on Studies of Moss Habitats and Distribution—Ruth Schornherst, Florida State College for Women. 10 min.
6. A New Concept of Florida Soils—Edward T. Keenan, Keenan Soil Laboratory, Frostproof. 15 min.
7. Notes on the Histology of *Siren*—George G. Scott, Winter Park. 5 min.

11:10 A. M. to 12:15 P. M.—MOTION PICTURES

(Marine Studios, St. Augustine, and Florida Reptile Institute, Silver Springs)

1:45 to 3:00 P. M.—GENERAL SESSION—Annie Russell Theater
President R. I. Allen presiding

PRESENTATION OF PAPERS

1. Pretended Accuracies in Computations—B. P. Reinsch, Florida Southern College. 25 min.
2. The Experimental Techniques of Scientific Psychology Versus the Speculative Dogmas of Educational Psychosophy—C. P. Heinlein, Florida State College for Women. 15 min.
3. Resonance in the Telephone and in the Cochlea—Max F. Meyer, University of Miami. 20 min. (With demonstration.)

3:00 to 3:30 P. M.—INTERMISSION

3:30 to 5:00 P. M.—BIOLOGICAL SCIENCES SECTION

Room 523, Knowles Hall

Chairman L. Y. Dyrenforth presiding

PRESENTATION OF PAPERS

1. The Basal Metabolism of College Women as Influenced by Race and Degree of Activity—Lola Schmidt and Jennie Tilt, Florida State College for Women. 15 min. (Illustrated.)
2. A Comparison of the Plant Associations and Physiography of the Apalachicola and Ocklockenee Rivers Flood Plains—Herman Kurz, Florida State College for Women. 20 min. (Illustrated.)
3. Hitherto Unrecorded Vertebrate Fossil Localities in South-Central Florida—H. James Gut, Sanford. 10 min.
4. Suggestions Concerning the Teaching of Biology—George G. Scott, Winter Park. 25 min.
5. Holothurians from Biscayne Bay, Florida—Elizabeth Deichmann, Harvard University. (By title.)

3:30 to 5:00 P. M.—PSYCHOLOGY SECTION—Room 509, Knowles Hall

Professor C. P. Heinlein presiding

PRESENTATION OF PAPERS

1. Mental Hygiene in Secondary Education—W. Leroy MacGowan, Lee High School, Jacksonville. 15 min.
2. Variations within Successive Categories of an Extended Series of Extra-Sensory Discriminations—Elizabeth A. Becknell, Florida State College for Women. 20 min.
3. Psychometric Results and Notes on Behavior Before and After a Pre-frontal Lobotomy on a Mental Patient—Philip Worchel, Florida State Hospital, Chattahoochee. 15 min.
4. Are Women Clairvoyant?—Julia H. Heinlein and C. P. Heinlein, Florida State College for Women. 20 min.

6:00 to 8:00 P. M.—BANQUET—(Informal)

Assembly Room, Angebilt Hotel, Orlando

Toastmaster: Charlotte B. Buckland, Vice-President of the Academy.

Address of Welcome: Hamilton Holt, President, Rollins College.

Retiring Address¹: Robert I. Allen, President of the Academy.

Presentation of the Achievement Medal for 1937: W. S. Phillips, Chairman, Achievement Medal Committee (1937).

¹“Science versus Unemployment,” *Science*, Vol. 89, No. 2317 (May 26, 1939), pp. 474-9.

SATURDAY, NOVEMBER 19, 1938

8:30 to 10:00 A. M.—BIOLOGICAL SCIENCES SECTION

Room 523 Knowles Hall

Chairman L. Y. Dyrenforth presiding

PRESENTATION OF PAPERS

1. The Role of Hormones and Vitamins in the Development of Higher Plants—William C. Cooper, Bureau of Plant Industry, U. S. Department of Agriculture, Orlando. 20 min.
2. Additions to the Recorded Pleistocene Mammals from Ocala, Florida—H. James Gut, Sanford. 10 min.
3. Notes on the Sharks of Florida—Stewart Springer, Bass Biological Laboratory, Englewood. 15 min.
4. Ovulation Time in Primates—J. H. Elder, Yale Laboratories of Primate Biology, Orange Park. 15 min. (Illustrated.)
5. A Report on the Habits of Florida Terrapins—E. Ross Allen, Florida Reptile Institute, Silver Springs. 12 min.

8:30 to 10:00 A. M.—PHYSICAL SCIENCES SECTION

Room 509, Knowles Hall

Chairman B. P. Reinsch presiding

PRESENTATION OF PAPERS

1. Conditions for Algebraic Solutions of Differential Equation $Mdx + Ndy = 0$ where M and N are Polynomials—Barbara Davis, Apopka. 15 min.
2. The S-H Frequency of the Mercaptans—Dudley Williams, University of Florida. 10 min.
3. Suggestions for an Improved Notation in Trigonometry—H. H. Germond, University of Florida. 5 min.
4. The Neutron—D. C. Swanson, University of Florida. 15 min.
5. An Infra-Red Study of Several Liquid Crystals—Richard Taschek and Dudley Williams, University of Florida. 10 min.
6. The Design of Numerical Problems for Instructional Efficiency—H. H. Germond, University of Florida. 20 min.

10:00 to 10:30 A. M.—INTERMISSION

10:30 to 11:40 A. M.—GENERAL SESSION—Annie Russell Theater

President R. I. Allen presiding

PRESENTATION OF PAPERS

1. Semantic Analysis: A Basic Step in Scientific Method—C. P. Heinlein, Florida State College for Women. 20 min.
2. The Necessity for Artesian Water Conservation in Florida—Sidney A. Stubbs, University of Florida. 10 min.

11:45 A. M. to 12:15 P. M.—BUSINESS SESSION—Annie Russell Theater

12:15 P. M.—COUNCIL MEETING (Both new and retiring members)

COMMITTEES FOR THE 1938 ANNUAL MEETING

COMMITTEE ON LOCAL ARRANGEMENTS

Guy Waddington, Rollins College, *Chairman*
W. S. Anderson, Rollins College
R. T. Robinson, Orlando
G. G. Scott, Winter Park
Bernice C. Shor, Rollins College
E. R. Weinberg, Rollins College
W. Yothers, Orlando

NOMINATING COMMITTEE

Herman Kurz, Florida State College For Women, *Chairman*
R. S. Bly, Florida Southern College
C. B. Buckland, Landon High School, Jacksonville
J. H. Clouse, University of Miami
S. A. Stubbs, University of Florida
C. B. Vance, Stetson University
Sarah P. White, Florida State College for Women

MEDAL COMMITTEE

R. C. Williamson, University of Florida, *Chairman*
E. Deviney, Florida State College for Women
L. Y. Dyrenforth, St. Luke's Hospital, Jacksonville
E. D. Hinckley, University of Florida
M. Mulvania, Florida Southern College

RESOLUTIONS AND MEMORIALS COMMITTEE

B. P. Reinsch, Florida Southern College, *Chairman*
W. M. Barrows, Florida State College for Women
R. T. Robinson, Orlando

PUBLICITY COMMITTEE

E. F. Weinberg, Rollins College, *Chairman*
C. I. Mosier, University of Florida

AUDITING COMMITTEE

B. Faust, Edison Senior High School, Miami, *Chairman*
B. McAllister, Miami

THE ACHIEVEMENT MEDAL

The ACHIEVEMENT MEDAL OF THE FLORIDA ACADEMY OF SCIENCES is awarded annually for a noteworthy paper presented at the annual meeting.

For the 1938 Annual Meeting, the medal was awarded to Stewart Springer, Bass Biological Laboratory, Englewood, for his paper "Notes on the Sharks of Florida," published in this volume, pp. 9-41. The committee which selected the paper to receive the award is listed on page 7 of this volume.

RESEARCH GRANT

For 1938, the AMERICAN ASSOCIATION FOR THE ADVANCEMENT OF SCIENCE allotted \$50 for use as a grant in aid of research, to be awarded to a member of the FLORIDA ACADEMY OF SCIENCES.

The Council of the Academy awarded the grant to Sidney A. Stubbs, Florida State Museum, University of Florida, for field work in a study of the fauna, geographical distribution and structure of a recently discovered¹ artesian aquifer older than the Ocala limestone, and the relationship of this zone to other Eocene horizons of the Atlantic Coastal Plain.

CHANGES IN THE BY-LAWS

At the 1938 Annual Meeting certain divisions of the By-Laws were amended. The changes in these divisions are given below. All other portions of the By-Laws remain as given in Volume 2 of the *Proceedings*, pp. 92-94.

DIVISION III. OFFICERS.

3. The Secretary shall keep the records of the Academy and of the Council and shall act as Managing Editor of the PROCEEDINGS. He shall have charge of the sale and exchange of the PROCEEDINGS. Subject to the approval of the Council he may appoint an Assistant Secretary to assist him in performing his duties.

DIVISION V. PUBLICATIONS.

2. The PROCEEDINGS shall be under the immediate control of the Council, through an Editor, a Managing Editor, an Editorial Committee of which the Editor shall be Chairman ex-officio, and a Business Manager. The Editor, Editorial Committee, and Business Manager shall be appointed by the Council each year for the volume of the Proceedings of that year.

¹See S. A. Stubbs, "A Study of the Artesian Water Supply of Seminole County, Florida," these *Proceedings*, Vol. 2 (1937), pp. 24-36.

NOTES ON THE SHARKS OF FLORIDA ¹

STEWART SPRINGER

Bass Biological Laboratory, Englewood

The sharks, rays, and chimaeras make up the class, *Elasmo-branchii*. The fishes make up a separate class *Pisces*, and the differences between members of the two classes are considerable. While it is unnecessary to go into these differences here, I do wish to emphasize the fact that there is a large gap between the two groups, and to point out the necessity for the appreciation of these differences in taxonomic studies. Our knowledge of the *Elasmo-branchii* is not without its bright spots, but it is weak as compared to our knowledge of other vertebrate classes. In working out systems of classification, the taxonomist is fundamentally concerned with the morphological facts, but if there is a background of knowledge about the organism that is reasonably comprehensive, he can interpret the data derived from a study of the specimen, and erect a system with much greater meaning. The study of sharks is handicapped by both the lack of great collections of specimens and a background of knowledge about the life histories of those specimens before they entered the alcohol bin or bottle.

The fragmentary information I have gathered can not have much value unless it is followed up. My facts are too few for the interpretations or assumptions I have made, and the interpretations do not satisfactorily cover the facts. But a start must be made somewhere, and I do have a specific purpose in presenting this paper. Sharks are frequently bulky and hard to handle. They are expensive to collect and time consuming to examine. Museum facilities do not permit the storage of series of large specimens. Therefore, it is desirable to take the maximum advantage of any material that becomes available. A large quantity of material is collected by the shark fishery in Florida. Each shark is subject to some handling and at least one measurement, and at some stations, the catch is reported on daily. There has not been any general agreement on the names of the sharks included in these reports, and it is my hope to set some standard in the use of common names. I have given preference to common names in general use by the fishery without particular regard to the common names applied by ichthyologists.

¹ Awarded the ACHIEVEMENT MEDAL OF THE FLORIDA ACADEMY OF SCIENCES for 1938.

The scientific nomenclature applied to sharks is badly muddled, species have been poorly described, and where large species are concerned there are rarely any types. The obvious procedure of comparing sharks from different parts of the world is impractical. Consequently, I have emphasized some characters and described them in more detail, so that they may be compared with those characters for sharks in other parts of the world.

Most of the material used in the preparation of this paper has been collected at Bass Biological Laboratory by members of the staff, and at the stations of Shark Fisheries, Inc. I am particularly indebted to Mr. John F. Bass, Jr. for facilities for carrying out investigations, for financial assistance in gathering material, and for many helpful suggestions. I wish to thank the personnel of Shark Fisheries, Inc. and Mr. Ferd Dalton of Bass Biological Laboratory for their very helpful co-operation.

VARIATION AND GROWTH

The initial impression to be gained from an examination of shark specimens with an attempt to identify them, is that great variation in form exists; and variation in form there is, but a very large part of it is change in form due to growth, and a comparison of specimens of exactly equal size shows remarkable similarity of form. I originally thought that the measurements I had taken of *Isogomphodon limbatus* indicated variation in form, but an analysis of them led me to the discovery that two species were involved. Poey recognized and described *I. maculipinnis* years ago, but ichthyologists have not recognized his species, possibly because they have had to work with a small number of young specimens.

While the material has not been sufficient to treat problems statistically, it has been possible to draw some inferences from the series of measurements I have for a few species. Alteration of the body form, in the species of *Carcharinus*, is apparently much greater when maturity is reached. The snout becomes shorter and the fins become proportionately longer. The relative positions of the pectoral and first dorsal remain about the same, but the proportions of the head and tail regions are greatly changed. The size of the eye decreases proportionately with age in *Carcharinus milberti* and probably in *Carcharinus obscurus*, but in *Carcharinus platyodon* the relation of the eye size to total length remains about the same.

Maturity is reached at a fairly definite size in each of the species I have studied. In so far as my material goes, adult sharks of any given species are all about the same size. I have no doubt but that

the size range of adults is a useful character for the separation of species. Unfortunately, I cannot get any conclusive data for the larger species. Most of the adult tiger sharks taken by the Florida shark stations range from ten and a half to thirteen feet in total length. It is possible that some individuals as long as fifteen feet have been taken, but I have not found any objective evidence of these very large ones. I have seen probably twenty thousand tiger shark teeth, taken in Florida and West Indian waters in the past two years, and in the lot there have been none that exceeded the teeth of a thirteen foot specimen in size. This might be conclusive evidence that extremely large individuals exist only as abnormalities except for the fact that the shark fishery uses a more or less standardized equipment which will catch some thirteen foot sharks and not much more. The two great white sharks recorded here were taken on unusually strong equipment, a combination of steel cable and rope, probably capable of withstanding a much greater strain than the ordinary chain lines.

REPRODUCTION

Fertilization is internal in all the sharks. The young are either born alive, or the fertilized eggs are deposited in heavy impervious egg cases. Within the class *Elasmobranchii* there is an amazing variety in specialization of structures to effect internal fertilization and to provide nourishment for the developing embryos. The number of young born at one time varies greatly with different species. Some of the smaller sharks have a fairly definite period for reproductive activity each year and mature females collected in the proper month will all contain embryos. For the tiger shark and the three large *Carcharinus*, there does not appear to be any certain period at which embryos can be collected. It is possible that they are produced at irregular intervals. I have not collected any reliable data on the sex ratio of the large sharks. I have had difficulty in getting measurements of enough mature males of the larger species, although I have always selected males for examination when there was any choice.

FEEDING HABITS

Probably most of the sharks are of little importance as enemies of food fishes. A possible exception is the sand-tiger. The common tiger shark may devour enough of the spiny lobsters to be of economic importance. The mako shark and the great hammerhead get injured or spent game fish. The mako may be fast enough to catch some of the larger uninjured fish, but if the hammerhead gets any it must be on the basis of its superior maneuverability.

MIGRATION

Sharks move about, sometimes for considerable distances, but no investigations of the extent and regularity of their migrations have been made. At Englewood, there are several species which we have taken only in winter and several species which have been collected only in summer. At Salerno, this division is much less clear cut.

TABLE I

PRESENCE OF ONE OR MORE INDIVIDUALS IN CATCH OF ENGLEWOOD SHARK STATION OR IN COLLECTIONS OF BASS BIOLOGICAL LABORATORY (indicated by X)

Shark	Jan.	Feb.	Mar.	Apr.	May	June	July	Aug.	Sept.	Oct.	Nov.	Dec.
Nurse			X		X	X	X	X	X	X		
Gulf smooth hound	X	X	X								X	X
Tiger		X		X	X	X	X	X	X	X		X
Bull				X	X	X	X	X	X	X		
Black nosed	X	X	X	X	X	X	X	X	X	X	X	X
Sand-bar	X	X	X								X	X
Dusky	X	X										X
Spot-fin			X	X	X	X	X	X	X	X		
Black-tip	X	X										X
Lemon			X	X	X	X	X	X	X	X		X
Common hammerhead	X	X	X	X		X					X	X
Great hammerhead			X	X	X	X	X	X	X	X		
Sand tiger		X	X									

The fluctuations in the percentage of a given species in the total weekly catch suggest an irregular wandering on the part of large schools or looser aggregates of individuals. Of the seventeen species taken at Englewood, the free swimming young of only eight have been collected, and I doubt whether the shallow water off Englewood is within the range in which the other nine liberate the young.

THE SHARK FISHERY

Sharks are not used as food in this country, and at present the flesh of sharks taken in Florida has no market value. The carcasses have been cut into strips, dried, and ground for fertilizer but this has been carried out on an experimental basis and most of the carcasses of sharks caught in Florida are discarded. The dried fins find a ready market at a high price per pound for fishery products. The hides are the most valuable single product of the shark fishery, and as the supply is not great, the chances of overproduction are slight. The liver oil is in demand and most of the better quality oil

taken from the Florida shark fishery is processed by a Florida company. Most of the revenue derived from the Florida fishery comes from the hides, fins, and liver oil. The teeth are sometimes sold, and it is probable that the carcasses will eventually be utilized. Investigations are being made as to the possibilities for the production of a very active pepsin from the stomachs of freshly killed sharks.

The industry in Florida is not large, but it is not beset by the dangers of overproduction, and should flourish as long as the supply of sharks remains at the present level. The industry should know how far it can expand without the dangers of overfishing. Biologists can only guess without knowing more about the life histories of the sharks. Questions of the rate growth of the various species, the number of young produced, the frequency of the production of young, the nature and abundance of the food supply, and the kinds of natural enemies should be answered. Probably the best and quickest way to get at these problems is by tagging the young sharks.

1. *Ginglylostoma cirratum* (Gmelin). THE NURSE SHARK.

The nurse sharks are confined to the tropical and semi-tropical waters of the western hemisphere. It appears to be problematical whether more than one species exists, but only one is to be found regularly on the coasts of Florida, where it is common south of the latitude of Tampa, and is present in summer at least as far north as the state line.

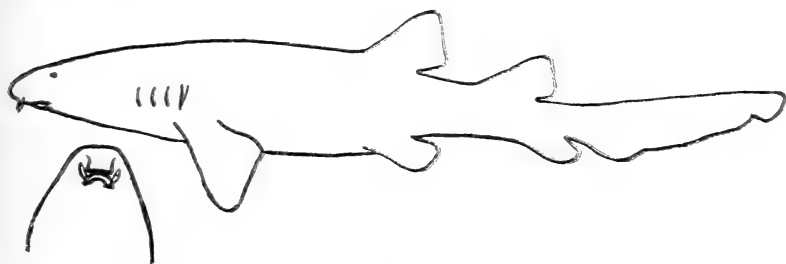

FIG. 1.—THE NURSE SHARK, *Ginglylostoma cirratum*

Mature specimens are from seven and a half to eleven feet long. They are big headed, somewhat flattened sharks with relatively small, but enormously powerful jaws. The jaws are armed with many small teeth, several rows of which are functional. The mouth is close to the tip of the snout, but is definitely inferior and is preceded by a pair of cylindrical nasal cirri. The color is a rich uniform brown, lighter on the belly. Young individuals are spotted with darker color and the spots occasionally persist on old ones.

The dermal denticles are heavy, close-set, and smooth, forming a very strong armor. No doubt this armor is important to a heavy bottom-feeding shark inhabiting coral reef areas, and it is probable that it makes the nurse shark nearly immune to the attacks of other sharks.

The species is said to come into shallow water for mating. Complete shells are produced for the eggs but these are thought to be retained until after hatching.

Nurse sharks take hooks baited with fish, and the stomach of one large specimen from Englewood contained a quantity of crab shell.

The hides bring a slightly higher price than those of other local species, but the fins are not in demand and the liver oil yield is relatively low.

2. *Mustelus canis* (Mitchill). THE COMMON SMOOTH HOUND.

No Florida specimens of this species have passed through my hands, but I have seen specimens from Cuban waters and from the

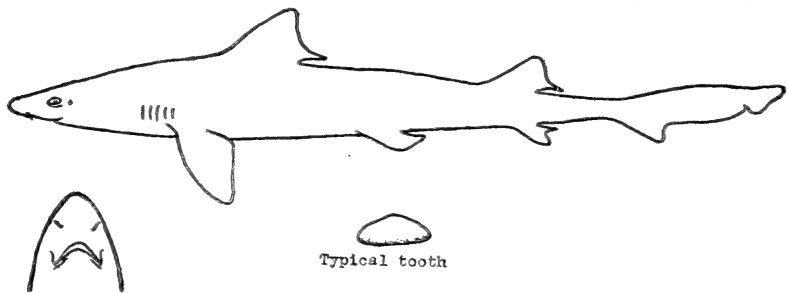

FIG. 2.—THE COMMON SMOOTH HOUND, *Mustelus canis*

coast of Virginia. Smooth hounds are abundant in winter off Norfolk in relatively deep water, usually from November through February; but during this period they travel in large compact schools, which, I am told by fishermen, are not easy to locate in the coldest part of the winter. No doubt they come further south, as the existence of Cuban specimens would indicate, and deep-water fishing with otter trawls in winter on the east coast of Florida might be expected to produce specimens.

At Norfolk I examined a lot of some five thousand pounds of smooth hounds, all taken in one drag by an otter trawl in about fifty fathoms. These were taken in early February, and ranged in length from 510 mm. to 1100 mm. Sexually mature specimens in this lot were all more than 750 mm. in total length. Most of the large

females contained embryos at about the same stage of development; the embryos from 200 mm. to 260 mm. long. The average number of young carried by females, in a lot of ten examined after preservation, was eleven. The embryos are nourished by means of a pseudo-placenta, at least for the later period of development.

During the warmer months the smooth hounds move northward and into shallow water and are rare south of New Jersey.

3. *Mustelus norrisi* Springer. THE GULF SMOOTH HOUND.

This small, slender, smooth dogshark is known only from a series of adult males taken at Englewood and a single female with embryos taken near Key West in 1906. All were collected in the winter months. I have been told by Englewood fishermen, who know the species, that during February, 1938 large numbers were taken in mackerel nets off Naples, Florida. As the fish fauna of the Gulf of Mexico in waters of moderate depth is little known, it is not surprising that the species has been infrequently taken. It is possible that the Gulf smooth hound is common in waters of fifty fathoms and that it comes into shallow water only when the temperature of the water is down.

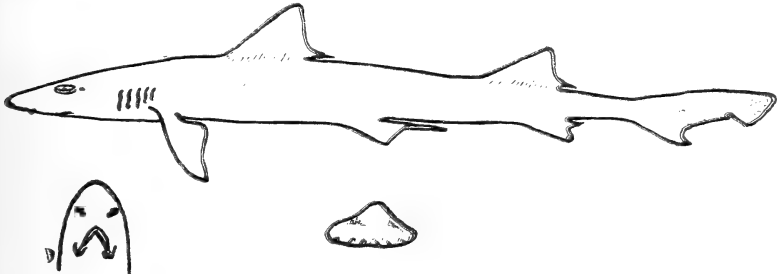

FIG. 3.—THE GULF SMOOTH HOUND, *Mustelus norrisi*

Mustelus norrisi is very close to *Mustelus lunulatus* Jordan and Gilbert, which is found in the Gulf of California. It differs chiefly in having the origin of the first dorsal back of the inner angle of the pectoral instead of in advance of it. *Mustelus norrisi* may be distinguished from *Mustelus canis* by a comparison of the teeth and jaws of adult specimens. In the Gulf smooth hound the jaw is narrow, strongly arched, and the line of occlusion of the jaws forms an angle of 90 degrees or less at the middle of the mouth. The teeth are high crowned. In the common smooth hound the teeth are low crowned and the angle formed by the jaws is more than 90 degrees. With the characters given in the key, identification of the two forms should be comparatively easy.

4. *Galeocerdo arcticus* (Faber). THE TIGER SHARK.

The common name most frequently applied to this shark by Florida fishermen is leopard shark, the name tiger shark being given to the big sand shark, *Odontaspis*. *Galeocerdo arcticus* has a wide distribution in warm seas and the term tiger shark is in general use for it and preferable. Tiger sharks are present on the coasts of peninsular Florida throughout the year, and are probably present in the north Gulf and in Atlantic waters north of Florida during the warmer months.

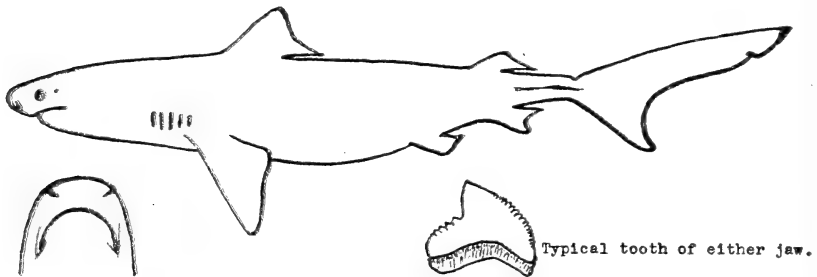

FIG. 4.—THE TIGER SHARK, *Galeocerdo arcticus*

Young specimens are spotted or banded with darker color, but these markings are obscure or absent on large individuals. The shape of the teeth especially, together with the presence of small spiracles and heavy lateral keels will serve to distinguish this species from all other sharks.

Tiger sharks are probably the largest and most powerful of the common species to be found on the Florida coast. The large coarsely serrate teeth are extremely efficient cutting instruments. Only one series is functional and the bites taken by the shark are generally smooth and clean. Bites on large objects are made by a rolling motion with both jaws cutting much in the manner of a saw, and if the object bitten is large enough to offer resistance, the tiger shark is quite capable of cutting through bone and shell. These sharks are very destructive to gill nets, biting out great holes to take a single fish, and, swimming back and forth through the nets as they feed on the gilled fish, they pile up many hours of net mending for the unlucky fisherman.

Stomachs of tiger sharks taken at Englewood most frequently contained horseshoe crabs, small sharks or pieces of large ones, small sea turtles or pieces of large ones, sting rays, tin cans, cormorants, spiny lobsters, and migratory birds such as warblers. Horseshoe crabs formed the largest part of the stomach contents and very

few bony fish remains were found. Although spiny lobsters are not often taken at Englewood, the remains were regularly taken from tiger shark stomachs in the spring of 1938. Probably this shark may be classed as an important enemy of the larger crustaceans and the horseshoe crab as well as a scavenger.

From thirty to fifty young may be born at a time. There is evidently no special period of the year at which the young are liberated. Early and late embryos have been taken from Englewood specimens in April and very early embryos have been found in June.

The tiger shark is one of the most valuable species to the shark fishery. The hides, liver oil, and fins find a ready market. The liver of a single specimen may yield as much as fifteen gallons of high quality oil. The amount of oil in the liver of female sharks seems to be correlated with the development of the young, a high oil content being present when there are ripe ova in the oviducts and a low oil content being present when there are nearly full term embryos.

5. *Prionace glauca* (Linnaeus). THE GREAT BLUE SHARK.

This is a very large shark, more truly pelagic than any of the other species of the family *Carcharinidae*. It is found in most seas,

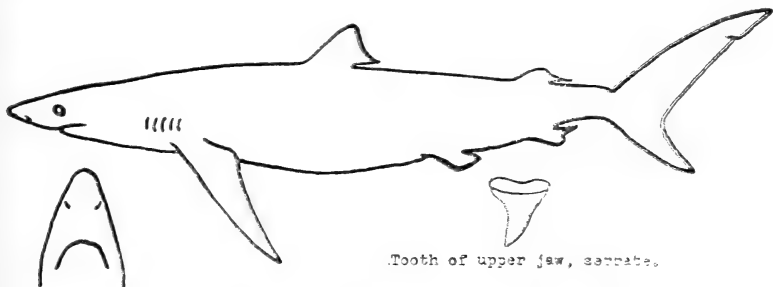

FIG. 5.—THE GREAT BLUE SHARK, *Prionace glauca*

but is apparently rare in Florida waters. I have seen one photograph of a catch of sharks, taken by anglers off Miami, which may include a specimen of this species, and I have one lot of teeth from a small specimen from the Salerno shark station carcass dump. Mr. Mooney, manager of the station, assures me that the teeth must have come from the stomach of some other species, and that no great blue sharks have come in.

Blue sharks are said to reach a length of twenty or twenty-five feet. There is no equipment at any of the shark stations that would

hold a specimen of such size, and large, wandering individuals may be much commoner than captures indicate.

The curved serrate teeth of the upper jaw, differing in shape from those of the lower jaw, afford the best means of identifying the species.

6. *Scoliodon terra-novae* (Richardson). THE SHARP-NOSED SHARK.

Several species of the small sharks of the genus *Scoliodon* have been described from the West Indian region. While a large number of specimens have been taken at Englewood, and these specimens do

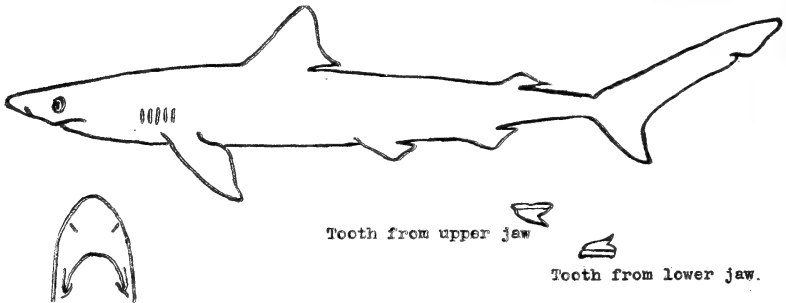

FIG. 6.—THE SHARP-NOSED SHARK, *Scoliodon terra-novae*

show more range of variation than I have seen in other ground sharks, I have not compared them with series from other localities and have not compared series of summer and winter collection. It is possible that two species may be involved, and that both are regularly present in south Florida waters. The sharp-nosed sharks range from Cape Cod to Brazil and are common on the Florida coasts. They are small sharks, about three feet long when mature, and consequently, of little importance to the commercial fishery.

Scoliodon terra-novae differs from species of *Carcharinus*, *Hypoprion*, *Isogomphodon*, and *Aprionodon* in having relatively long labial grooves running forward from the corners of the mouth; and in having teeth similar in shape in the upper and lower jaws, oblique, deeply notched on the outer margins, with the points of all but the central teeth directed toward the angles of the jaws.

Large schools of sharp-nosed sharks frequent the passes into Mississippi sound during the summer months but are absent during the winter. Collections were made there during the months of June through September in 1931, 1932, and 1933. In the total catch of

many hundreds of individuals, only a few (less than ten) half grown specimens appeared. Early in the summer, only adult males were collected on hook and line in any quantity. Females were present in the area, but not in schools with the males, and only a small number were taken on hook and line. In August the newborn young were frequently taken on hook and line in the sound, and in September the schools of adult sharks included a large proportion of females.

At Englewood, specimens have been taken in all months and the number of half-grown specimens is proportionately great in both spring and fall catches. In mid-summer the species is not common. Females with early embryos have not been taken.

7. *Carcharinus platyodon* (Poey). THE BULL SHARK.

Bullhead shark has been used in Florida as a name for this species, but I propose the name bull shark because the former name has wide acceptance for species of sharks of the family *Heterodontidae*. In Florida, the species is also called mackerel shark or mullet shark because it is supposed to follow schools of these fishes. Actually, the bull shark is probably too slow to catch either, and mackerel shark is a better name for the swift, fish-eating sharks such as the mako, in which the lower caudal lobe is well developed, forming a tail fin similar in shape to that of a mackerel.

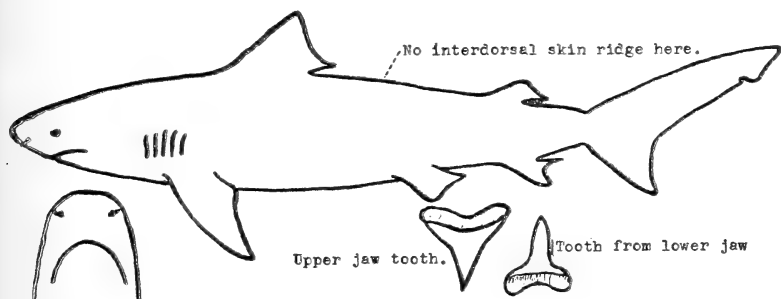

FIG. 7.—THE BULL SHARK, *Carcharinus platyodon*

Most authors have included both this species and another closely related one, *Carcharinus commersonii* in accounts of the West Indian fauna. I have seen but one form from Florida, and, on rather slender evidence, have chosen to recognize it as distinct from the Mediterranean *Carcharinus commersonii*. On theoretical grounds I would be inclined to doubt the existence of West Indian

specimens of that species. Poey's description of *Carcharinus platyodon* is a good one, and covers characters not subject to variation or growth changes.

The genus *Carcharinus* is a large one, well represented in the shore waters of most temperate and tropical seas. It includes an assemblage of sharks of medium and large size, which are very similar in appearance, although differences in the shape of the teeth, in the structure of the dermal denticles, and in the relative positions of the fins are sometimes considerable. In so far as the material I have examined is concerned, the Florida species do not show any marked variation. The characters which have been used for the demarcation of species have frequently been those relating to length of fins, length of tail, and length of snout. As I have already pointed out, these characters are modified during growth, and while they may be useful when large series are available for the identification of species, they are misleading in giving the impression of variation in form within a species. The characters I have given in the accompanying key are apparently stable, nevertheless, identification of specimens within the genus *Carcharinus* is sometimes difficult.

Carcharinus platyodon is found on the Gulf and Atlantic coasts of Florida, and ranges through the West Indies from Texas to the Carolinas. At Englewood, we have not taken specimens in December, January, or February, the species being then replaced by *Carcharinus milberti* and *Carcharinus obscurus*.

The bull shark is a large, heavy bodied species, becoming mature at slightly more than seven feet in length and reaching a little more than nine feet. The snout is short and broadly rounded, its length being much less than the width of the mouth. The color is usually light gray above and white below, without any conspicuous fin markings. A few of the specimens I have seen have been quite dark, and it is possible that the form occurs in two color phases, or that the color may be modified by environmental factors. There is no trace of an interdorsal ridge. The origin of the first dorsal is in advance of the inner angle of the pectoral fin. Typical teeth of the upper jaw are nearly erect and triangular, only slightly angled toward the sides of the mouth, serrate and quite sharp. Typical teeth of the lower jaw are erect and narrow, with fine serration. The lower jaw teeth may be described as two rooted; that is, the lower surface of the basal portion is quite concave, and the enamel line of the outer surface curves upward at the center of the tooth. The lower jaw teeth are proportionately heavier than those of the

dusky shark and the sand-bar shark, with the point more abruptly tapering. The tooth count on seventeen mature specimens taken at Englewood was $\frac{12 \ 1 \ 12}{12 \ 1 \ 12}$ to $\frac{13 \ 1 \ 13}{13 \ 1 \ 12}$. In this formula the figures above the line refer to the number of rows of teeth in the upper jaw, twelve or thirteen rows on either side of the jaw and one central tooth at the symphysis.

8. *Carcharinus acronotus* (Poey). THE BLACK-NOSED SHARK.

Specimens of this small species have been taken on the Atlantic coast at least as far north as the Carolinas, and the species is abundant on the west coast of Florida. I have seen at least one specimen from Biloxi, Mississippi, and the species was described by Poey from Cuban specimens. It does not reach a large enough size to be of importance to the commercial fishery.

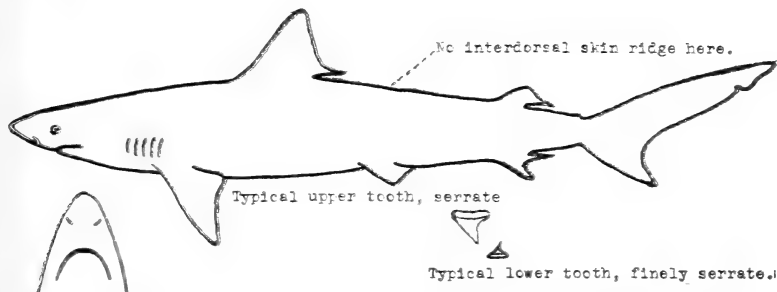

FIG. 8.—THE BLACK-NOSED SHARK, *Carcharinus acronotus*

The black-nosed sharks taken at Englewood have appeared in two color phases. Most of them were cream colored above and white below, without definite fin markings, but with the snout tipped with darker color. Some were uniform brown except for the darker snout tip. While the black or darker colored nose is a good field recognition mark for fresh specimens, I am not sure that the color would be especially noticeable on preserved ones. The nose spot is well marked on young, but becomes obscure and diffuse on old adults.

These sharks are mature at about three feet four inches, and may reach a length of four feet six inches. The origin of the first dorsal is over or slightly behind the inner angle of the pectoral. There is no interdorsal skin ridge. The teeth of the upper jaw are strongly notched on the outer margin, oblique, and roughly triangular in outline. Serrations on the teeth of the upper jaw are just visible to

the naked eye. The teeth of the lower jaw are narrow and erect on broad bases, and the serrations can be seen only with the aid of a microscope. Tooth counts of ten mature specimens from Englewood run from $\frac{12 \ 1 \ 12}{11 \ 1 \ 11}$ to $\frac{13 \ 2 \ 13}{11 \ 1 \ 11}$.

At Englewood nearly full term embryos have been collected from January to April, three to six being taken from a single female.

Full grown black-nosed sharks have frequently been taken from the stomachs of tiger sharks and bull sharks.

9. *Carcharinus milberti* (Valenciennes). THE SAND-BAR SHARK.

It is not improbable that there are two species in the material I have seen and referred to *Carcharinus milberti*. Both Mr. Charles Mooney and Mr. Guy Hunt of Shark Fisheries, Inc., tell me that they have noticed two kinds of sand-bar sharks in their catches on the east coast of Florida, one is the smaller and commoner, more off-shore species which is certainly *C. milberti*, Mr. Mooney tells me that the other form is larger and is taken on the inshore lines. In my measurements of Englewood sharks, I have noted one specimen which I originally thought to be *Carcharinus falciformis* (Bibron). Subsequently, I removed this specimen from consideration because of an obvious error in one of the pectoral fin measurements. The specimen was much too large, nine feet nine inches, for a sand-bar shark, the origin of the first dorsal was almost over the inner angle of the pectoral instead of well in advance, and the tooth count was $\frac{15 \ 2 \ 15}{14 \ 1 \ 14}$ near the extreme for the sand-bar shark. Unfortunately, I did not make an examination of the dermal denticles and did not save a skin sample.

The exact range of the sand-bar shark is not known. Certainly, it is found on the coast of the northern states in summer, and, although I can find no definite record of the species for Florida, it is the most abundant of the commercially valuable sharks taken at Salerno on the east coast of Florida. We have it with *Carcharinus obscurus* at Englewood, replacing *Carcharinus platyodon* in the catch of the shark station during late December, January, February, and early March in the winter of 1937-1938.

In the northern part of its range this form has been called the brown shark but all the specimens I have seen from Florida have been slate-gray. It is possible that, along with *Carcharinus acrono-*

thus, this shark may have color phases or have the color modified by the environment.

The sand-bar shark may be distinguished from other Florida species of the family most certainly, by an examination of the dermal denticles with a microscope. In the sand-bar shark, typical denticles on the skin of the side a few inches below the mid-dorsal line are widely spaced, not touching one another, and with the skin showing through. The denticles are three to five ridged in adults, wider than long, and with the points made by the ends of the ridges at the posterior end of the denticles scarcely projecting.

No very satisfactory characters have been given in the past for separating *C. milberti* from all the rest of the genus, and while the material I have seen is not sufficient to do this, some comparisons may be of interest to students. Both *Carcharinus japonicus*

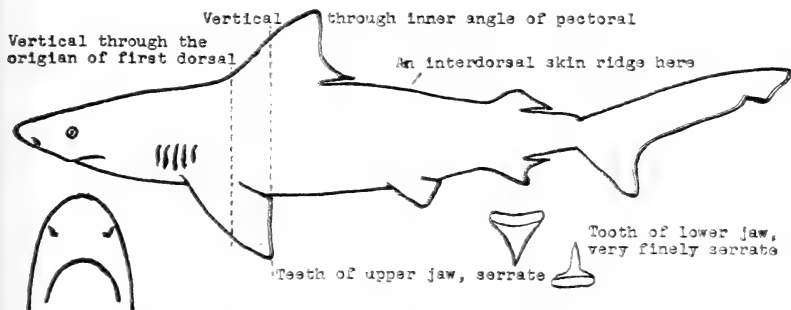

FIG. 9.—THE SAND-BAR SHARK, *Carcharinus milberti*

(Schlegel) and *Carcharinus dussumieri* (Muller and Henle) have widely spaced denticles, broader than long, and both have an interdorsal skin ridge, although in the specimens I have seen, the spacing of the denticles is not so wide as in *C. milberti*. The teeth of *C. japonicus* are smaller in specimens of comparable size, and more oblique in the upper jaw, resembling those figured in Muller and Henle, "Der Plagiostomen," 1841, for *Carcharias menisorrhah* Muller and Henle. The very oblique teeth of the upper jaw and the long slender nasal flap serve to distinguish *C. dussumieri* from *C. milberti*. In all three species the relative positions of the second dorsal and anal are somewhat variable and entirely worthless for consideration as distinguishing features.

Unless the larger inshore form already mentioned turns out to be the same as the common offshore form it should be possible to set a fairly definite limit to the size range of the species. For the present,

I shall eliminate the larger form from the discussion, and assume that it is an unidentified species or the hybrid of *C. milberti* and the closely allied *C. obscurus*.

The sand-bar shark becomes mature at about six feet eight inches, and very large specimens may be as much as seven feet ten inches in total length. It is a heavy bodied shark, but not quite so big-headed as the bull shark. The width of the mouth of adults is about one and one-half times the length of the snout, measured from the front of the mouth. There is an interdorsal skin ridge. The origin of the first dorsal is well in advance of the inner angle of the pectoral. In adults the pectoral fins are long, and when folded back along the sides, reach well past the end of the base of the first dorsal. The distal margin of the pectorals of adults is somewhat concave. In the embryos, however, the pectorals reach past the base of the first dorsal, but the distal margin is nearly straight. The origin of the second dorsal is either over, slightly in advance, or slightly in back of the origin of the anal.

The teeth are comparatively larger than those of the dusky shark and comparatively smaller than those of the bull shark. The upper teeth are similar in shape to those of the bull shark, usually as high or higher than broad and centrally nearly erect, while the lower teeth are similar to those of the dusky shark, but are smaller, narrower, and without the cupped base and central groove of the lower teeth of the bull shark. The tooth count in the specimens examined has

run from $\frac{14 \quad 1 \quad 14}{13 \quad 1 \quad 13}$ to $\frac{15 \quad 2 \quad 15}{14 \quad 2 \quad 14}$.

Three, of the sixteen mature females taken at Englewood, carried embryos, all from 380 mm. to 440 mm. in length, and in litters of eight, eleven, and twelve. No young sand-bar sharks have been collected at Englewood.

10. *Carcharinus obscurus* (Lesueur). THE DUSKY SHARK.

The dusky shark is known from the Atlantic coast of the United States. I do not find definite records of the species from Florida, but it is to be found on the lower west coast, at least in winter, and on the east coast is common throughout the year.

It is a larger species than either the sand-bar shark or the bull shark, and has a proportionately longer snout and smaller teeth. The presence of an interdorsal skin ridge in specimens of all ages will distinguish the dusky shark from the bull shark. It differs from the sand-bar shark in having the origin of the first dorsal in back of the inner angle of the pectoral rather than in advance, and

in having the distal margins of the pectoral fins of the embryos concave.

The upper surface is dirty gray and the lower surface white with the lower surface of the pectoral fins tipped with black. Some specimens are very light in color and the species is occasionally referred to as the white shark. The second dorsal is smaller than the anal and about opposite it. The teeth of the specimens examined usually give a slightly higher count than the teeth of *C. milberti*, but

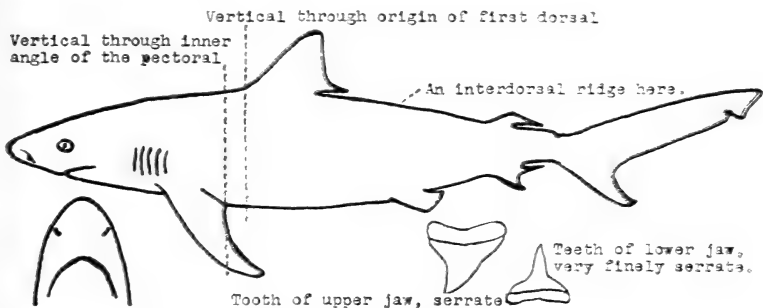

FIG. 10.—THE DUSKY SHARK, *Carcharinus obscurus*

counts from the two species are overlapping. The tooth counts of the dusky shark have run from $\frac{14 \ 2 \ 14}{14 \ 1 \ 14}$ to $\frac{15 \ 3 \ 15}{14 \ 3 \ 14}$. The upper teeth are broadly triangular, with the margin toward the angles of the jaws concave and the opposite margin convex. Typical teeth are broader at the base than high, the height measured along the tooth axis. The teeth of the lower jaw are narrow, erect, and have broad bases without the central groove and cupped base which is characteristic of the teeth of *C. platyodon*. The upper teeth are coarsely serrate, and the lower teeth are very finely serrate on the cusps only.

Nine adult females, ranging in length from ten feet four inches to eleven feet eight inches, were examined. Two of them carried embryos. One litter of ten, taken at Englewood on January tenth, included embryos from 575 mm. to 585 mm. long. Embryos of the second lot, taken January twenty-first, were from 950 mm. to 965 mm. long.

Dusky sharks have been collected at Englewood only in December, January, and February, and no young, half-grown individuals, or adult males have appeared in the collections made there.

11. *Isogomphodon limbatus* (Müller and Henle). THE SPOT-FIN SHARK.

The recent tendency of taxonomists has been to regard this species as one of almost cosmopolitan distribution, with wide variation in form, as the size and shape of the teeth, and in the number of rows of teeth. An examination of the large numbers of specimens collected by the Englewood shark station has shown, that instead of one variable species, we have two species without marked variation for the characters mentioned. It seems unlikely to me that *Isogomphodon limbatus* ranges much beyond the West Indian region

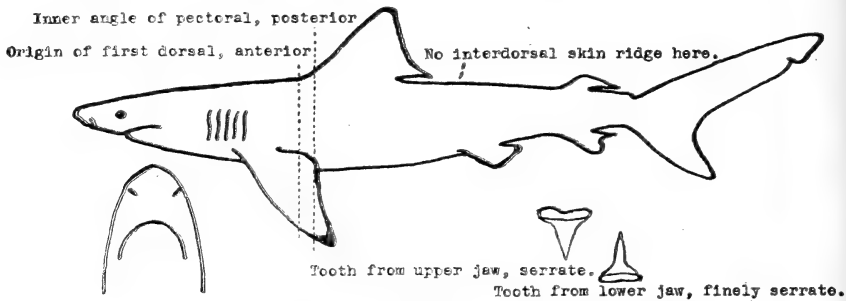

FIG. 11.—THE SPOT-FIN SHARK, *Isogomphodon limbatus*

except possibly up the Atlantic coast of North America as a migrant. As this and the following species have generally been considered synonymous, and the diagnostic features are not given in faunal lists and other publications, it is difficult to assign a range to either. *Isogomphodon limbatus* has been taken at Englewood in all months except December, January, and February, at which time, it is replaced by *Isogomphodon maculipinnis*.

I. limbatus may be mature at six feet in length and probably does not ordinarily reach a length of more than seven and a half feet. It is probably swifter than species of *Carcharinus*, and it does manage to catch some bony fishes. Although it is at least as abundant, it does not appear so often in the stomachs of the larger sharks as *Carcharinus acronotus*. Both the species of *Isogomphodon* give a fast and furious fight when taken on hook and line, often leaping clear of the water. It is possible to wear them out more easily than the kinds of sharks that come up and fight the boat.

Both the species of *Isogomphodon* are gray above and white below with the tips of the pectorals black. The other fins are often black tipped or edged with darker. The line formed on the sides by the meeting of the darker dorsal color with the lighter ventral color is

usually clear cut and the lighter stripe, shown in the figure of *I. limbatus*, is definite, although it appears in many species of *Carcarinus* and related genera, it consequently has little value as a diagnostic feature. There is no interdorsal ridge. The teeth of the upper jaw of this shark are very narrowly triangular on broad bases, with straight-sided somewhat oblique cusps, and serrations which are visible to the naked eye on all but very small specimens. The teeth of the lower jaw have narrow, erect cusps, the sides of which are sub-parallel except near the tip. The teeth are slightly recurved forward near the tip and the cusps are very finely serrate, the serrations just visible to the naked eye on large specimens. The largest tooth of the upper jaw of a six foot six inch male taken at Englewood was 11 mm. from the tip to the enamel line. The largest tooth of the lower jaw of the same specimen was 10 mm. from the tip to the enamel line. The tooth counts of thirteen mature specimens of *limbatus* taken at Englewood run from $\frac{14 \ 2 \ 15}{13 \ 2 \ 14}$ to $\frac{15 \ 3 \ 15}{15 \ 1 \ 15}$.

Full term embryos, 540 mm. to 570 mm. long, were taken from an Englewood specimen captured April fourteenth. The young and half-grown individuals are common at Englewood except in winter.

12. *Isogomphodon maculipinnis* Poey. THE BLACK-TIP SHARK.

The species was described from Cuba and was common at Englewood during January, February, and March 1938. Nothing further appears to be known about the range. This species is very similar in appearance to the preceding. It probably reaches a little larger

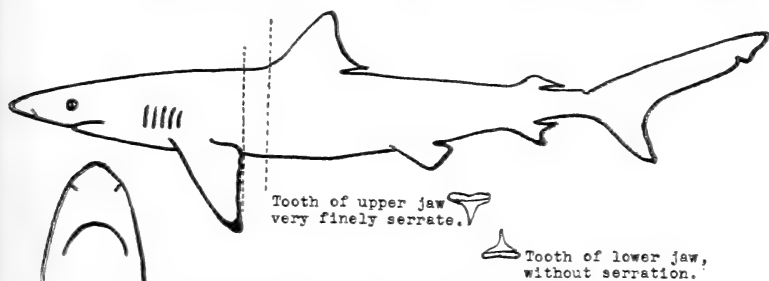

FIG 12.—THE BLACK-TIP SHARK, *Isogomphodon maculipinnis*

size. Three males, taken at Englewood in January, were all between seven, and seven feet six inches long.

Aside from the differences given in the key, *maculipinnis* may be distinguished from *limbatus* by its more slender form, sharper and

longer snout, and more intense colors. These characters, however, are unreliable, and apparently subject to some variation. Local fishermen who have seen numbers of both species recognize *maculipinnis* because it is "keener," the term probably referring to the trim and streamlined appearance given by the pointed snout and the definite color pattern.

The teeth are much smaller than the teeth of *limbatus*, the largest tooth of the upper jaw of a seven foot male being 7 mm. from the tip to the enamel line, and the largest tooth of the lower jaw of the same shark being 6 mm. from the tip to the enamel line. The upper jaw teeth are narrower than those of *limbatus* and the serrations are just visible to the naked eye in large specimens. The lower jaw teeth do not have the tip recurved forward as in *limbatus* and their edges are entire. The tooth count of eight adult specimens taken at Englewood run from $\frac{16 \ 2 \ 16}{16 \ 1 \ 15}$ to $\frac{17 \ 3 \ 17}{16 \ 1 \ 16}$.

Neither embryos nor very young individuals have been seen.

13. *Hypoprion brevirostris* Poey. THE LEMON SHARK.

This large West Indian shark regularly goes up the Atlantic coast as far as the Carolinas and is common on the west coast of Florida at least as far north as Tampa.

It is a heavy bodied shark with large fins and a short, broad snout; usually yellowish brown, but sometimes dark brown. There are no spots or markings of color. The dermal denticles are large and rough to the touch. The second dorsal fin is nearly as large as the first dorsal. There is no interdorsal skin ridge and the origin of the first dorsal is in back of the inner angle of the pectorals. The species may be mature at about seven and a half feet and reaches a length of about eleven feet.

The teeth have rather narrow cusps on broad bases. The upper jaw teeth are a little wider than the lower and the edges of the cusp are entire. The bases of the upper jaw teeth are irregularly serrate. The edges of both cusps and bases of the lower jaw teeth are entire. Tooth counts of eight mature specimens of the lemon shark run from $\frac{14 \ 2 \ 13}{12 \ 2 \ 13}$ to $\frac{15 \ 2 \ 15}{14 \ 3 \ 14}$.

A large female was present in the shallow, salt-water creek adjoining Bass Biological Laboratory on June first, and was under observation frequently for several hours before darkness. The following morning the large shark was gone, but young with open umbilical scars were present. Two of these small specimens, taken

June second, were 624 mm. and 630 mm. long. The young were frequently seen in the creek until July twelfth, but left shortly after. Two specimens taken from the creek on the twelfth were 730 mm.

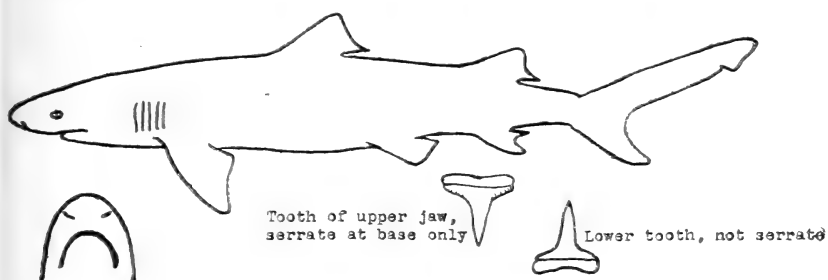

FIG. 13.—THE LEMON SHARK, *Hypoprion brevirostris*

and 750 mm. long. Under the circumstances, I think it very likely that only one litter was present in the creek, and it is probable that an increase in length of 100 mm. the first month is normal. I have records of new born specimens from shallow inlets on the west coast of Florida south of Englewood in May, June, July, and September.

The lemon sharks make up a considerable portion of the catches of the shark fishery. The hides, fins, and oil are of good quality and the species reaches a large enough size to be worth handling.

14. *Aprionodon isodon* (Müller and Henle). THE SMOOTH-TOOTHED SHARK.

This species is evidently rare. At least it is uncommon in our waters. According to Jordan and Evermann it has been taken from

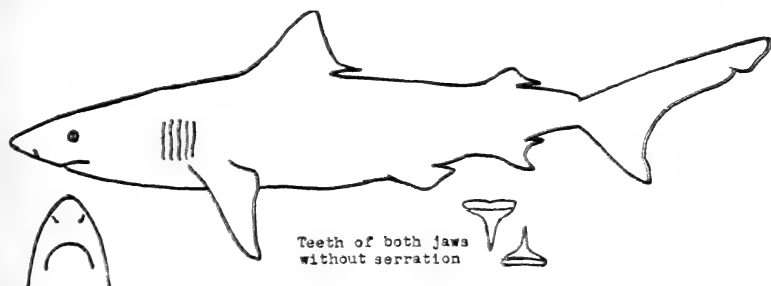

FIG. 14.—THE SMOOTH-TOOTHED SHARK, *Aprionodon isodon*

New York, Virginia, and Cuba. H. W. Norris secured several specimens at Englewood, and I have collected three at Biloxi.

Radcliffe records one from Beaufort, and gives a good description of it.²

The specimens I had were immature, and under two and a half feet long. The species may be recognized by the smooth pointed teeth, which are without serrations on the bases or cusps. The gill slits are comparatively longer than in related species to be found in our waters.

15. *Sphyrna tiburo* (Linnaeus). THE SHOVEL-NOSE SHARK.

This species is thought to have a world wide distribution. Probably specimens from one part of the world have not been compared with series from another part of the world. These are bottom feeding sharks and one would suppose that populations of them might be isolated from one another by broad expanses of deep water. Comparisons would certainly be interesting.

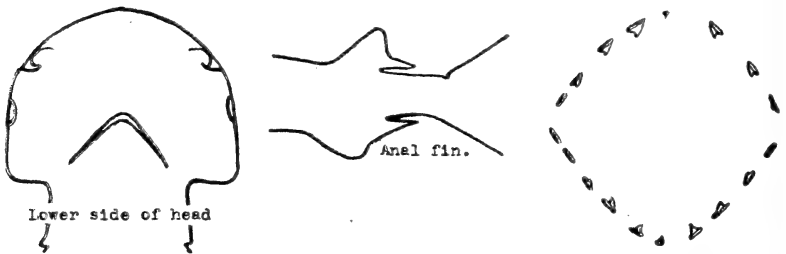

FIG. 15.—THE SHOVEL-NOSED SHARK, *Sphyrna tiburo*

There are so many conflicting bits of information about this species and the hammerheads in the literature that I hesitate to add confusion to the situation without being able to clear up some of the points. Unfortunately, about all I can contribute is the opinion that there are more species than have been recognized, and that the relationships within the family cannot be cleared up until comparisons of series of specimens are made.

The question of genera to which the various forms should be referred may best be left until species have been more adequately defined. The shovel-nosed shark has been placed in Gill's genus *Reniceps* by some authors, and the older name of Swainson, *Platysqualus*, has been used to harbour the great hammerhead on the grounds that Swainson's reference to a figure in Russell depicts the great hammerhead. However, Swainson describes *Platysqualus*,

² "The Sharks and Rays of Beaufort, North Carolina," *Bulletin U. S. Bureau of Fisheries*, Vol. 34 (1914), pp. 252-3.

"Head more or less heart-shaped" and, by no stretch of the imagination can I see how that could be applied to the great hammerhead, either more or less. Heart-shaped has frequently been used to describe the head of the shovel-nose. The description, then, is definite and diagnostic. Judgments about the intent of Swainson seem useless. We evidently have two parts to the description which are in conflict and one of them must be thrown out. It would seem the better policy to use the part of the description that Swainson himself produced, and if a separate genus is required for the shovel-nose sharks, *Platysqualus* of Swainson should be used. In the characters of skull shape and tooth form, the Florida west coast shovel-nose is closer to the smaller Florida hammerhead, a form which I tentatively call *Sphyrna zygaena* (Linnaeus), than to the great hammerhead *Sphyrna tudes* (Cuvier).

The shovel-nose sharks may easily be distinguished from the hammerhead sharks by the characters given in the key. The following discussion refers only to specimens collected at Englewood, and undoubtedly all of the same species. The largest specimen in the lot of several hundred I have seen from Englewood was 110.0 cm. long (43½ inches). The tooth count of ten adult specimens runs from $\frac{12 \ 1 \ 12}{12 \ 1 \ 12}$ to $\frac{14 \ 1 \ 14}{13 \ 1 \ 13}$. The teeth of the upper jaw have rather low pointed cusps, very oblique, and with the points directed toward the angles of the jaws. The cusps of the last two or three rows of teeth toward the angles of the jaws have very low cusps or the cusps are entirely absent. The lower teeth are similar except that the cusps are more nearly erect and the last four rows of teeth have cusps extremely small or absent. None of the teeth have serrate edges.

At most seasons, specimens up to three and a half feet are common at Englewood, but I have no record of midsummer captures. An examination of stomach contents has shown that crabs form a large part of the diet.

16. *Sphyrna zygaena* (Linnaeus). THE COMMON HAMMERHEAD.

The Florida form of the common hammerhead may be readily separated from the great hammerhead by the characters presented in the key. Attention is particularly called to the shape of the second dorsal fin. The very long posterior lobe on the relatively low fin is characteristic and a reliable field mark.

The teeth are never serrate and are usually in $\frac{16 \ 0 \ 16}{15 \ 1 \ 15}$ rows.

The upper teeth are oblique and narrowly triangular, with the points directed toward the angles of the jaws. The margins of some of the teeth are curved so that the points are directed straight out from the jaw. The lower teeth are slender and are more erect.

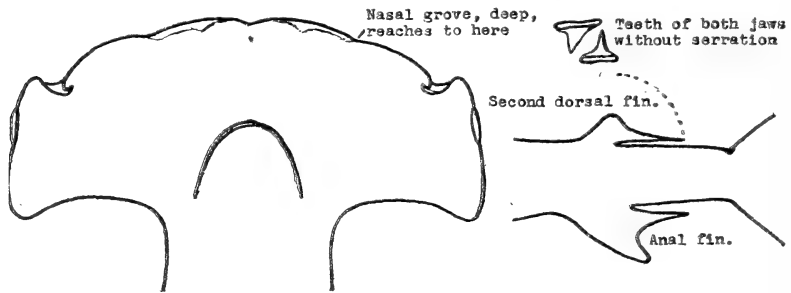

FIG. 16.—THE COMMON HAMMERHEAD, *Sphyrna zygaena*

The common hammerhead is more abundant at Englewood in winter and specimens of all sizes up to nine feet have been taken. No embryos have been collected. A few young individuals have been secured in the late spring.

17. *Sphyrna tudes* (Cuvier). THE GREAT HAMMERHEAD.

At least a part of the original description of *Sphyrna tudes* applied to specimens collected at Cayenne but Mediterranean specimens are mentioned as well. The plate accompanying the description in "Memoires du Museum d'Histoire Naturelle," M. A. Valen-

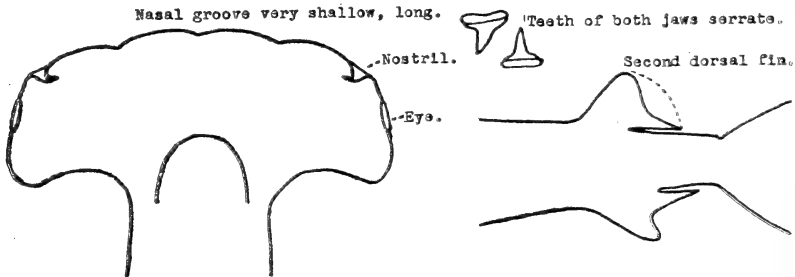

FIG. 17.—THE GREAT HAMMERHEAD, *Sphyrna tudes*

ciennes, Paris, 1822, pl. II, fig. 1a & 1b, is a poor illustration of the Florida *Sphyrna tudes*, and it may represent one of the Mediterranean specimens. Compared with the illustration, the Florida form has the mouth further back and larger. In Florida *tudes*, a line through the angles of the mouth is posterior to a line along the

posterior edge of the hammer. The anterior edge of the hammer in the illustration is more curved, the eyes are further forward and smaller, and the nasal groove is depicted as more prominent than in Florida specimens.

The great hammerhead probably reaches a much greater size than the common hammerhead. Thirteen foot specimens are often taken and there seems to be reliable evidence that fifteen foot individuals have been secured. Apparently the species is not mature at less than ten feet long. No great modification in form has been noted during growth except that the hammer becomes more exactly transverse in old adults, much more so than in adults of the common hammerhead.

The relative positions of the fins seems to be variable in this species as well as in the common hammerhead and the shovel-nose.

The teeth of the great hammerhead are larger, in specimens of the same size, than the teeth of the common hammerhead. They are always serrate in both jaws, and the bases are very heavy. Tooth counts in most of the Englewood specimens have been $\frac{17 \ 2 \ 17}{16 \ 3 \ 16}$ with variations of plus or minus one from each figure of the formula.

At Englewood, the great hammerhead is more abundant in summer and large specimens have not been taken in winter. Three females with embryos have been taken, all in early June. Of these, a twelve foot specimen contained 30 embryos, and two thirteen foot specimens carried 37, and 38 embryos respectively.

18. *Rhineodon typicus* Smith. THE WHALE SHARK.

The whale shark is an enormous shark of the open seas. E. W. Gudger has recorded specimens from the coast of Florida where it

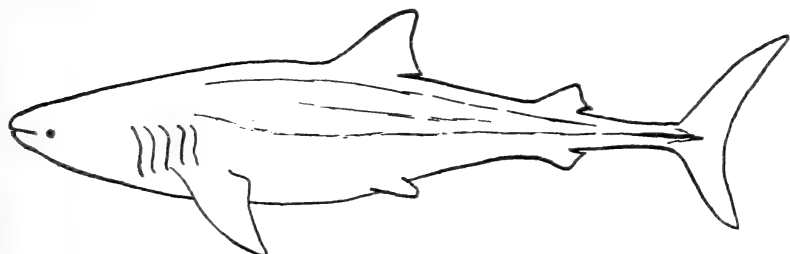

FIG. 18.—THE WHALE SHARK, *Rhineodon typicus*

apparently is about as common as anywhere else. I have not seen one. Dr. Gudger, in various papers, has given about all that is known of the species.

19. *Alopias vulpinus* (Bonnaterre). THE THRESHER SHARK.

This species is not common in Florida waters. I have seen one small one said to have been taken near Miami. I collected one specimen of moderate size at Biloxi, Mississippi.

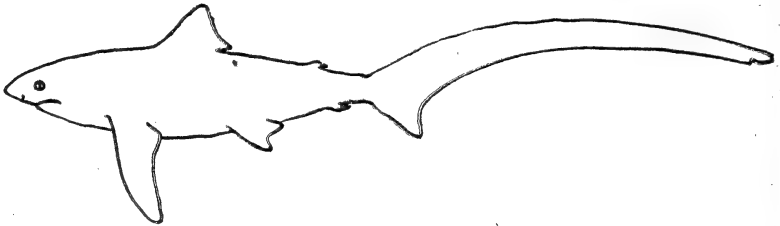

FIG. 19.—THE THRESHER SHARK, *Alopias vulpinus*

20. *Odontaspis littoralis* (Mitchill). THE SAND TIGER.

Two of these big ugly sharks have been taken at Englewood, one specimen nine feet two inches long, and the other ten feet five inches long, on February eighth and March thirteenth. They are often taken on the east coast at all seasons, appearing irregularly in considerable numbers off Salerno. I have compared our specimens with a small one, sent to me by Mr. Breder of the New York Aquarium, and can find no noteworthy differences. Evidently, only the large specimens have been taken in south Florida waters and only small specimens on the northeast coast of the United States.

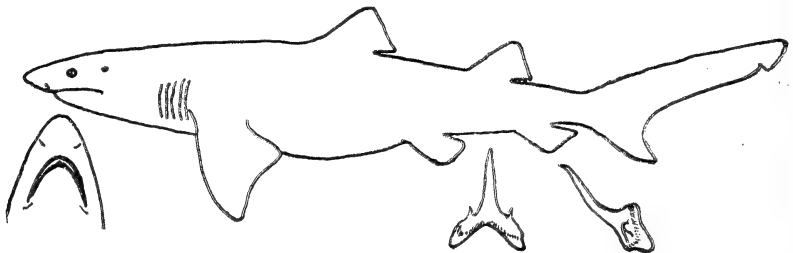

FIG. 20.—THE SAND-TIGER, *Odontaspis littoralis*

The sand tiger bears a superficial resemblance to the lemon shark, but the snout is sharp pointed and the color is usually gray instead of brownish. In both, the second dorsal fin is comparatively large, nearly as large as the first dorsal. The teeth of the sand tiger are very long, slender, and sharp, with small accessory cusps on either side of the main cusp. There may also be rudiments of third cusps on either side. None of the teeth are serrate. The central ones in both jaws are long, in the ten foot five inch specimen the longest

tooth is 30 mm. from the tip to the enamel line, the lateral ones are very short, almost paved. The teeth are similar in both jaws. The fourth lateral teeth, counted from the symphysis, in the upper jaw are small, and the first laterals of the lower jaw are small. At least two series and sometimes three are functional. The tooth counts of the two Englewood specimens are $\frac{19 \ 4 \ 4 \ 20}{21 \ 1 \ 1 \ 20}$ and $\frac{19 \ 4 \ 4 \ 18}{17 \ 1 \ 1 \ 16}$.

A single jaw from Salerno in my possession has the tooth count $\frac{17 \ 3 \ 4 \ 16}{15 \ 1 \ 0 \ 15}$. These three counts indicate a wide variation in

the tooth formula. The bases of the sand tiger teeth are hard, much harder than in any of the sharks of the family *Carcharinidae* and similar to those of the mackerel sharks and great white shark in that respect.

Both the Englewood sharks were adult females but neither carried embryos. When these sharks were captured both of them were enormously distended and on opening them we found that the stomachs contained bony fish, probably a hundred pounds in each. There were a large number of the shark remoras, *Echeneis naucrates*, small *Pogonias cromis*, *Menticirrhus sp.* and *Chaetodipterus faber*. Among the species of fish represented by a few specimens were *Cynoscion nebulosus* and *Mugil cephalus*.

21. *Isurus oxyrinchus* Rafinesque. THE MAKO SHARK.

No mackerel sharks have been taken or sighted at Englewood. I have one set of jaws from off Havana which probably were taken

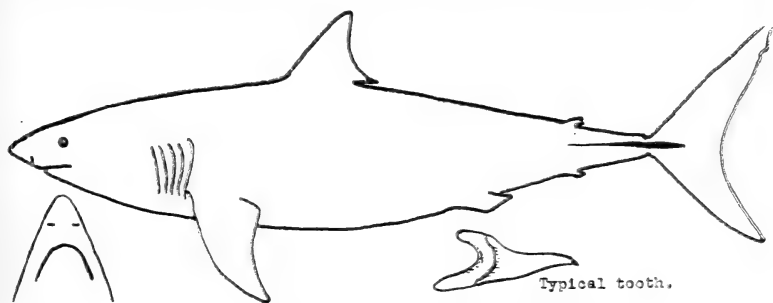

FIG. 21.—THE MAKO SHARK, *Isurus oxyrinchus*

from a specimen of this species, and there is a cast in the Pflueger Museum in Miami of a specimen which I believe should be referred to *Isurus oxyrinchus*. *Isurus tigris* (Atwood) is supposed to be present in the Gulf of Mexico, although it would probably not often

be found in the shallow shore waters of the Florida west coast. *Isurus punctatus* (Storer) may also occasionally appear in Florida waters.

These are primarily fish-eating sharks, swift, powerful species of the open sea. They may be distinguished from other sharks except the great white shark (also a mackerel shark or member of the mackerel shark family) by the presence of a strongly developed lower caudal lobe, making the tail-fin nearly symmetrical.

22. *Carcharodon carcharias* (Linnaeus). THE GREAT WHITE SHARK.

One of these was taken by Mr. Holbrook and Mr. Green at Long Beach near Sarasota in the winter of 1936-1937 and a second specimen was taken by them the following winter. From a photograph, I judge that the second specimen was about fifteen feet long. A num-

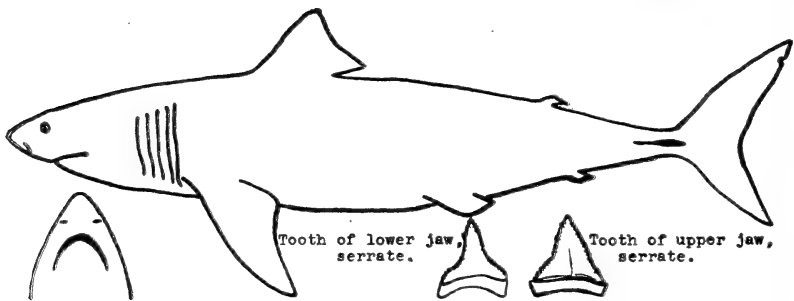

FIG. 22.—THE GREAT WHITE SHARK, *Carcharodon carcharias*

ber of the teeth were collected at the carcass dump of the Salerno shark station but Mr. Mooney tells me that these teeth must have come in in the stomachs of other sharks. It is possible that the species is much commoner than captures suggest. The species may be recognized by the characters given in the key.

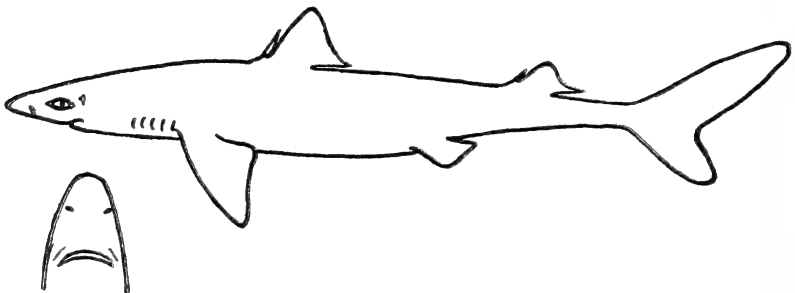

FIG. 23.—THE SPINY DOGFISH, *Squalus acanthias*

23. *Squalus acanthias* Linnaeus. THE SPINY DOGFISH.

The spiny dogfish was recorded from the Indian River by Evermann and Bean. I have no doubt that the species is occasionally present in large numbers in deep water off the east coast of Florida in winter.

KEY TO THE COMMON SHARKS OF THE SHALLOW WATERS OF FLORIDA

1. IF THE SHARK has no anal finIT IS A SPINY DOGFISH
Squalus acanthias
- BUT IF THE SHARK has an anal finREFER TO NO. 2
- 2—from 1. IF THE SHARK has no nasal cirriREFER TO NO. 3
- BUT IF THE SHARK has a pair of nasal cirri (small cylindrical feelers in front of the mouth)IT IS A NURSE SHARK
Ginglylostoma cirratum
- 3—from 2. IF THE SHARK has the mouth opening below the tip of the snout, i. e., inferiorREFER TO NO. 4
- BUT IF THE SHARK has the opening at the tip of the snout, i. e., terminalIT IS A WHALE SHARK
Rhineodon typicus
- 4—from 3. IF THE SHARK has teeth with sharp points or cutting edgesREFER TO NO. 6
- BUT IF THE SHARK has blunt paved teeth without sharp points or cutting edges....REFER TO NO. 5
- 5—from 4. IF THE SHARK has the tip of the lower lobe of the tail pointed, and if the mouth is strongly arched in front with its jaws forming an angle of 90 degrees or lessIT IS A GULF SMOOTH HOUND
Mustelus norrisi
- BUT IF THE SHARK has the tip of the lower lobe of the tail rounded, and if the mouth is not sharply arched in front, and forms an angle of more than 90 degreesIT IS A COMMON SMOOTH HOUND
Mustelus canis

- 6—from 4. IF THE SHARK
has a symmetrical tail fin, with
the lower lobe nearly as large
as the upper lobeREFER TO NO. 7
BUT IF THE SHARK has
an asymmetrical tail, with the
upper lobe much larger than
the lower lobeREFER TO NO. 8
- 7—from 6. IF THE SHARK
has broad, triangular, heavily
serrate teeth in the upper
jawIT IS A GREAT WHITE SHARK
Carcharodon carcharias
BUT IF THE SHARK has
long slender teeth, without serrate
edgesIT IS A MAKO SHARK
Isurus oxyrinchus
or one of the other mackerel sharks
- 8—from 6. IF THE SHARK
has an unusually long tail
which is more than one-third
the total length of the shark.....IT IS A THRESHER SHARK
Alopias vulpinus
BUT IF THE SHARK has
a shorter tail, less than one-
third the total length of the
sharkREFER TO NO. 9
- 9—from 8. IF THE SHARK
has the head expanded later-
ally to form a hammer or spade
shaped partREFER TO NO. 10.
BUT IF THE SHARK does
not have the head so expanded, REFER TO NO. 12
- 10—from 9. IF THE SHARK
has the anterior and lateral
margins of the head forming a
continuous curve, and the head
is spade shapedIT IS A SHOVEL-NOSE SHARK
Sphyrna tiburo
BUT IF THE SHARK has
the anterior and lateral mar-
gins of the head meeting to
form a definite angle, and the
head is roughly hammer-
shapedREFER TO NO. 11
- 11—from 10. IF THE SHARK
has the posterior lobe of the
second dorsal fin short, so that
when it is lifted straight up-
ward, it will reach only a little
higher than the upper tip of
the fin; and if the teeth are
serrateIT IS A GREAT HAMMERHEAD
Sphyrna tudes

BUT IF THE SHARK has the posterior lobe of the second dorsal fin long, so that when it is lifted upward it will reach a point about twice as high as the fin; and if the teeth are not serrate IT IS A COMMON HAMMERHEAD
Sphyrna zygaena

12—from 10. IF THE SHARK has the second dorsal fin nearly as large as the first dorsal fin, REFER TO NO. 13

BUT IF THE SHARK has the second dorsal fin small, half or less than half the size of the first dorsal fin REFER TO NO. 14

13—from 12. IF THE SHARK has a pointed snout, and if its long slender teeth have small toothlets on either side at the base IT IS A SAND-TIGER
Odontaspis littoralis

BUT IF THE SHARK has a broad rounded snout, and the teeth have no small cusps on either side of each large one, IT IS A LEMON SHARK
Hypoprion brevirostris

14—from 13. IF THE SHARK has spiracles; and has large, flattened, strongly serrate teeth with the points directed toward the angles of the jaws, and if the teeth are similar in both jaws IT IS A TIGER SHARK
Galeocerdo arcticus

BUT IF THE SHARK has no spiracles; and if the teeth are not as described for the tiger shark REFER TO NO. 15

15—from 14. IF THE SHARK has long labial folds, grooves in the skin running forward from angles of the mouth for a distance of not less than one-fifth of the width of the mouth (measured from angle to angle) IT IS A SHARP-NOSED SHARK
Scoliodon terra-novae

BUT IF THE SHARK has short labial folds or none REFER TO NO. 16

16—from 15. IF THE SHARK has slender, pointed teeth, without any serration at all (slide a sharp knife along the side

of the teeth of the upper jaw
to feel them if you cannot see
them)IT IS A SMOOTH-TOOTHED SHARK
Aprionodon isodon

BUT IF THE SHARK has
any serration at all on any of
the teethREFER TO NO. 17

17—from 16. IF THE SHARK
has the teeth of the upper jaw
flattened and broadly curved
on their outer and inner mar-
gins, forming a tooth like the
tip of a curved saberIT IS A GREAT BLUE SHARK
Prionace glauca

BUT IF THE SHARK has
teeth not so formed, and either
triangular, notched on the
outer margin, or erect and
slenderREFER TO NO. 18

18—from 17. IF THE SHARK
has a ridge in the skin, run-
ning at least partway between
the first and second dorsal
finsREFER TO NO. 19

BUT IF THE SHARK has
no trace of a ridgeREFER TO NO. 20

19—from 18. IF THE SHARK
has the origin of the first dor-
sal fin in back of the angle
formed by the free inner mar-
gin of the pectoral with the dis-
tal margin (inner angle of the
pectoral)IT IS A DUSKY SHARK
Carcharinus obscurus

BUT IF THE SHARK has
the origin of the first dorsal
fin in advance of the inner
angle of the pectoralIT IS A SAND-BAR SHARK
Carcharinus milberti

20—from 18. IF THE SHARK
has the pectoral fins tipped with
darker color, and has the teeth
of the upper jaw neither
broadly triangular nor sharply
oblique and notched on the
outer marginsREFER TO NO. 21

BUT IF THE SHARK does
not have the pectoral fins tipped
with darker, and has the up-
per teeth either broadly tri-
angular or sharply oblique and
notched on the outer margins, REFER TO NO. 22

21—from 20. IF THE SHARK

has the origin of the first dorsal over, or in advance of the inner angle of the pectoral; and if the teeth of the lower jaw (of full grown specimens) have some slight serration

IT IS A SPOT-FIN SHARK

Isogomphodon limbatus

BUT IF THE SHARK has the origin of the first dorsal in the back of the inner angle of the pectoral; and if the teeth of the lower jaw of full grown specimens have no serrations,

IT IS A BLACK-TIP SHARK

Isogomphodon maculipinnis

22—from 20. IF THE SHARK

has the snout very broadly rounded, without a black tip; and has the teeth of the upper jaw erect and broadly triangular

IT IS A BULL SHARK

Carcharinus platyodon

BUT IF THE SHARK has the snout somewhat pointed, and has a black spot or smudge on the tip; and if it has the teeth of the upper jaw oblique, with the points directed toward the angles of the mouth

IT IS A BLACK-NOSED SHARK

Carcharinus acronotus

VARIATIONS WITHIN SUCCESSIVE CATEGORIES OF AN EXTENDED SERIES OF EXTRA-SENSORY DISCRIMINATIONS

ELIZABETH ANN BECKNELL
Florida State College for Women

The piece of research here reported was carried on in the psychology laboratory at the Florida State College for Women during the regular session of 1937-38. It was the outgrowth of a desire to determine the dependability of a current theory in parapsychology and to provide material meaningful to further scientific investigation in the field of extra-sensory perception.

The literature in the field of parapsychology is extensive, but few adequately controlled experiments can be cited. Reliable scientific evidence on any phase of psychic research, including extra-sensory perception, is exceedingly meager.

As has been pointed out by Moore¹ in his review of the work in the extra-sensory field, the evidence for the existence of "mental telepathy" and "clairvoyance" is questionable as yet. He mentions the fact that methods for investigating the phenomena of extra-sensory perception are not standardized nor agreed upon. He feels that at the present stage of the investigation an agnostic position is the logical one to take—an attitude of not knowing. "Well planned research in this field should be encouraged. The white light of truth will expose the faker and the incompetent investigator no matter which side of the question he takes."

The most widely publicized and most extensive experimentation in extra-sensory perception has been carried on by J. B. Rhine at Duke University. In his book,² Rhine defines the statistical limits of extra-sensory perception, and, in the light of this definition, advances the theory that extra-sensory perception becomes more apparent in extended series of discriminations. The following excerpt (p. 167) will exemplify the theory which Rhine advances:

Above all, one must not, like several investigators, stop with only 25 or 50 or even 100 trials per subject. Most of my good subjects did not do very well in the first 100. With few exceptions, the first 50 to 100 trials give the worst scores. With all my major subjects this is true.

¹ Moore, J. E., "Is There Anything to Mental Telepathy?" *Peabody Journal of Education*, Vol. 15 (1937-38).

² Rhine, J. B., *Extra-Sensory Perception*, (Boston: Bruce Humphries, 1935).

In the light of Rhine's limited data, his theory concerning the shift in variation within an extended series of discriminations needs verification under experimentally controlled conditions. Does the theory, as he states it, find justification in fact when sensory cues are entirely eliminated and when adequate statistical techniques are applied to more extensive data? That is the question which this investigation proposes to answer.

For the preliminary experiments 118 young women from the classes in general psychology were employed as subjects. These students, numbering usually between twenty and thirty to the group, took part in the experiments during their regular class periods. The subjects were seated in the regular laboratory class-room and the experimenter was stationed in the next room, where the timing device was also located. A thick wall separated the two rooms. Both rooms opened on the hall and the heavy doors were closed during periods of experimentation.

On the first day of the experiment a few preliminary remarks were addressed to the various groups by the experimenter. These remarks were brief and stated, in essence, that the positive character of the results in the extra-sensory experimentation at Duke University had precipitated afresh the age-old controversy concerning clairvoyance and telepathy. It was pointed out that the parapsychologists at Duke were convinced of the reality of mental telepathy and their criterion for the operation of extra-sensory perception was a given deviation from chance expectation. It was also explained that the object of the present investigation was to determine to what extent the subjects would deviate from chance expectation in the particular experiment set up, all sensory cues having been eliminated. The preliminary remarks made to each group were essentially the same and were offered for the purpose of creating interest in the investigation. An open attitude was assumed by the experimenter with regard to the results at Duke and with regard to the extra-sensory field in general. Then the following directions were read to the subjects:

This is an experiment in mental telepathy. I shall be in the next room and at a given signal I shall concentrate upon one of these two symbols. (Hold up the cross and the circle.) You will hear the signal at the same time and will also concentrate in an attempt to determine whether I am thinking about the circle or about the cross. We will concentrate for a period of 13 seconds and then the buzzer will sound and you will record either a cross or a circle in the space opposite the number for that particular trial. You will be allowed

3 seconds in which to record your decision. Then the buzzer will sound again and the next period of concentration will begin immediately.

When the buzzer sounds for the first time it will be merely to show you what the signal is like. Very shortly after the first signal the buzzer will sound a second time. This is the signal for you to start concentrating. After 13 seconds the buzzer will sound again. This is the signal for you to record your decision. After 3 seconds the buzzer will indicate the beginning of the second concentration period and so on.

After the directions had been read, opportunity was given for questions pertaining to them. Score sheets were distributed among the subjects in order that they might record their own responses.

The chief piece of apparatus employed in the preliminary experiments was a synchronous electric time clock. A metal brush attached to a revolving hand projecting from the center of the dial made contact with small brass plates along the outer rim of the dial. Whenever the brush contacted one of the brass plates, two buzzers, connected in parallel with the clock circuit, were sounded. The brass plates were arranged at intervals of 14 seconds and 4 seconds respectively. One buzzer was located in the room with the subjects. Control of signalling was entirely automatic.

A table containing all apparatus except the one buzzer mentioned above was located in the room with the experimenter. The mechanical key used in checking responses and in determining the order of the symbols to be concentrated upon by the experimenter was arrived at by observation of the chance fall of two pennies shaken from a box. These pennies were shaken up in the box half a dozen times before being thrown out on the table and recorded as alike (both heads or both tails) or as different (one heads and one tails.) Three hundred throws of the pennies were made and recorded. The two possible combinations of patterns were found to distribute themselves in precisely a 50-50 ratio; one hundred and fifty times the pennies were alike and one hundred and fifty times they were different.

The trials which had resulted in likeness were arbitrarily selected to represent the circle, one of the symbols to be "sent" telepathically by the experimenter. The trials which had resulted in difference were likewise selected to represent the cross, the other symbol to be "sent" by the experimenter. The three hundred results were then typed on two sheets of paper, 150 to a sheet and 6 columns of 25 symbols on each page. The exact order in which the symbols had empirically occurred was preserved, since the purpose in designing such a key in the first place was to avoid "habits of thought" on the

part of the experimenter and to make possible an accurate statement of normal chance expectancy as precisely 50-50. A "chance" distribution was thus obtained, "chance" in this instance bearing the empirical rather than the theoretical connotation.

A small slot was cut in the center of a piece of white cardboard of the same size as the key sheets. The slot was of just the right dimensions so that when the cardboard was fitted over the key, one symbol alone would appear simultaneously with the number for that particular trial. The object of this precaution was to insure that the attention of the experimenter would not be diverted by the mass of symbols surrounding the one to be concentrated on at any given moment. Moreover, this arrangement was of service in keeping track of the correct place in the column.

Two cards from Rhine's regular ESP deck, a circle and a cross, were employed as the symbols to be concentrated upon by the experimenter. These were selected because of their simplicity and because they had apparently been found workable by Rhine.

The experimenter sat at a table in the adjacent room, facing a blank, white wall. The electrical apparatus and the mechanical key were located on this table. As soon as the key and the two cards bearing the chosen symbols were arranged before the experimenter, she started the timing device. At the sound of the buzzer the experimenter began concentrating on the card indicated by the mechanical key for that particular trial. When the buzzer sounded again she shifted the key to the symbol for the next trial. Approximately 150 trials were run at each experimental period of 45 minutes, a total of 300 trials being taken for every subject. With 118 persons participating, a grand total of 35,400 trials was run in the preliminary experiment.

When the 35,400 trials were completed, the results were checked and rechecked by means of the mechanical key. The raw scores for the 118 subjects were plotted in a frequency distribution. Projecting the parameters of the distribution against those of the Gaussian curve as reference criteria of the error function, it was found that the degrees of skewness and kurtosis were not significant. A test of curve fitness gave a probability of one in five that the result obtained was due to sampling errors alone. When the odds are five to one against a random sample giving as great deviations as those obtained, the error function of the normal curve may be used as a function of the obtained curve, provided that the demands made upon the derived limits of prediction by the coefficients of normal ordinate displacement are duly observed. In the observed distribu-

tion, the number of degrees of freedom assigned to the variates from theoretical mean expectation were determined without recourse to conventional methods of condensation of tail frequencies. Use of the latter methods of condensation would have provided a slightly better fit than the one obtained.

Since the number of discriminations scored correctly by any one student in the total distribution did not deviate significantly beyond the fourth probable error, it is not possible on statistical grounds to ascribe extra-chance characteristics to any individual performance if we are willing to define the concept of chance in terms of the error function criteria of the Gaussian curve.

In order to verify Rhine's theory that with practice a subject may increase his number of correct discriminations, the twenty subjects deviating to the greatest extent from normal chance expectancy were selected to serve as subjects in the main investigation. Ten of these selected to serve as subjects deviated in a positive direction from chance, having made the greatest number of hits, and the other ten deviated in a negative direction, having made the fewest number of hits.

The control in this second experiment was essentially the same as in the first experiment. The mechanical key and the two symbols for concentration were employed again exactly as in the preliminary experiment.

The twenty subjects selected to take part in the main project were interviewed individually by the experimenter. To each she pointed out the fact that the subject was a member of the selected group deviating to the greatest extent from normal chance expectation. It was further pointed out that experimentation was being continued for the purpose of investigating the trend of extra-sensory discriminations among this selected group over an extended series.

In view of the fact that many of the subjects were engaged in various extra-curricular activities and in view of the fact that no experiments could be conducted prior to 4:30 in the afternoon, it was impossible to have every individual work at exactly the same time every day. Instead, three periods of experimentation were conducted daily, Monday through Friday, and any subject was free to attend at any one of the three periods proving most convenient to her on any particular day. However, no more than ten persons were ever permitted to work at the same time. The experiment was run from 4:30 to 5:00, 5:30 to 6:00, and 7:30 to 8:00 P. M., the experimenter resting from the exigencies of concentration during the intervening periods.

At each half-hour period 120 trials were completed by each subject. Approximately 2,000 trials were completed by the group each day and approximately 10,000 trials were completed each week. Make-up work was customarily handled on Saturday afternoons.

On the first day of the main experiment directions were again read to the subjects. These directions were essentially the same as those for the first experiment, with the exception that the time intervals for concentrating and recording were reduced from 14 seconds and 4 seconds to 10 seconds and 3 seconds respectively since several students at the close of the preliminary experiment remarked that the time allotted for reception and recording was longer than necessary. Also attention was drawn to the fact that both a bell and a buzzer would be employed in signalling, thus avoiding any confusion resulting from the use of the buzzer alone. The remaining details of the procedure were entirely similar to those of the preliminary experiments.

A total of 60,000 discriminations from all subjects was secured, each subject having made 3,000 discriminations at the close of the experiment. A frequency distribution of all 60,000 discriminations was plotted and tested for normalcy against the parameters of the Gaussian curve of errors. In terms of the chi-square test of curve fitness, it was found that there are only 7 chances in 100 that the chi-square obtained is attributable to some factor other than chance. The probability of 93 in 100 indicates a statistically insignificant degree of difference between the actual frequencies and the theoretical frequencies, and represents an excellent match between theory and observation. The critical ratio expressed in terms of the probable error to the specific error taken from theoretical mean expectancy is, therefore, applicable to the empirical distribution for the purpose of demonstrating sampling limits and the function of variance according to the hypothesis in which 4 probable errors on either side of the central tendency set off the limits within which chance fluctuations are said to operate.

Approximately 25,000 more responses were obtained in the main than in the preliminary experiment, and, whereas in the earlier investigation only 300 trials were given to each individual, precisely ten times that number were given each subject during the main investigation. Hence, it is interesting to note that with an extended number of categories the total response picture assumes a distribution whose chi-square is superlatively good rather than one whose chi-square is only medium or fair as was the case with the earlier study.

A consideration of the individual histograms for each of the twenty persons acting as subjects for the main investigation reveals considerable variability in the configuration of individual performance. Chi-square values obtained for the individual distributions range all the way from 51.3 where n is 14 to 10.4 where n is 15. Despite this marked variation, it is to be remembered that the value for P obtained from the chi-square for the total distribution of 60,000 responses is 0.93, considerably higher than that of the best (i.e. most nearly normal) individual distribution. In other words, with the addition of more scores the curve tends to smooth itself out and to approach the ideal normal curve to a superlative degree.

Taking a score of 60 hits as expressing the theoretical mean expectancy of a single category of 120 individual discriminations made by any given subject during any given experimental period, it is found that in the total distribution of 500 categories only two categories extend 5% of the total distance of a single P. E. unit beyond the 4th P. E. limit. The great bulk of the scores fall within 3 P. E. (plus or minus) from normal chance expectation, 485 of the 500 categories resulting in scores lying within these limits and 419 of them within the limits of 2 P. E. Scores falling between 3 and 4 P. E. on either side of the theoretical mean occurred in only thirteen instances. In the two cases where the 4 P. E. limit was exceeded it was not surpassed by the same individual both times, nor by a distance which would be termed significant, the deviation being 15 units above or below theoretical chance expectation in either instance, and the 4th P. E. extending to 14.8 units. It is interesting to note that the deviation of +15 was obtained by a subject scoring below chance in the preliminary experiment, and that the deviation of -15 was obtained by a subject scoring above chance in the preliminary trials.

In conclusion it may be stated that an evaluation of the data in its entirety reveals no score which is not readily explainable in terms of the chance hypothesis as based on the Laplace-Gaussian curve. In the light of a discussion by Sorenson³ and in the light of the rule of parsimony, an essential step in scientific interpretation, it is unnecessary to posit any extra-sensory factor to account for scores made by any or all of the twenty subjects. Since the normal curve has its limits theoretically approaching infinity and practically approaching the total range of achievement, the amount of the total area extending the 5% of one P. E. beyond the 4th P. E. limit can

³ Sorenson, Herbert, *Statistics for Students of Psychology and Education*, (New York: McGraw-Hill, 1936), p. 288.

not be regarded to have serious weight, either theoretically or practically.

In direct contradistinction to the theory advanced by Rhine, the analysis of individual performance curves reveals no consistent variation either in a positive or a negative direction within successive categories. Those subjects who had scored high on the preliminary experiments evinced about the same tendency toward sporadic, unpredictable shift on successive periods as those who had scored low. Hence, pure guessing is sufficient explanation of the results obtained.

HITHERTO UNRECORDED VERTEBRATE FOSSIL LOCALITIES IN SOUTH- CENTRAL FLORIDA

H. JAMES GUT
Sanford

SANFORD, SEMINOLE COUNTY—Fossils were dredged from Lake Monroe by hydraulic dredges during the years 1926-32. Collecting has been going on from 1926 to the present time. During high water stages in the lake, wave action washes out fossils from the hydraulic fill and they are then collected during low water stages.

<i>Isorus sp.</i>	Mackerel shark
<i>Lamna sp.</i>	Mackerel shark
<i>Carcharodon sp.</i>	Mackerel shark
<i>Galeocerdo sp.</i>	Requiem shark
<i>Hemipristis sp.</i>	Requiem shark
<i>Glyphis sp.</i>	Requiem shark
<i>Myliobatis sp.</i>	Eagle ray
<i>Rhinoptera sp.</i>	Eagle ray
<i>Enchodus sp.</i>	Extinct family
<i>Labrid</i>	Wrasse fishes
<i>Chelonia</i>	Tortoises and turtles
<i>Alligator mississippiensis</i>	Alligator
<i>Didelphis virginiana</i>	Opossum
<i>Sylvilagus sp.</i>	Rabbit
<i>Castoroides ohioensis</i>	Giant beaver
<i>Hydrochoerus pinckneyi</i>	Giant capybara
<i>Procyon lotor</i>	Raccoon
<i>Lynx rufus</i>	Bobcat
<i>Mylodon harlani</i>	Harlan's ground sloth
<i>Holmesina septentrionalis</i>	Giant armadillo
<i>Equus complicatus</i>	Horse
<i>Odocoileus osceola</i>	Fla. White-tailed deer
<i>Bison sp.</i>	Bison
<i>Mastodon americanus</i>	American mastodon
<i>Parelephas columbi</i>	Columbian mammoth
<i>Trichechus sp.</i>	Sea cow

WEKIVA RIVER, SEMINOLE COUNTY—During the fall of 1934 three local men while fishing in the Wekiva River observed through the crystal clear water a large lower jaw lying on the sand bottom. They dived over-board and after breaking it into several pieces succeeded in getting it into their boat. They then observed numerous

bones lying on the river bottom, scattered up and down the stream for a distance of several hundred feet. As they were out of work at the time they spent the next three weeks in recovering all of the bones in sight. Approximately one-half of a mastodon skeleton was recovered and two molars of a mammoth. Through the writer's efforts these specimens are now owned by the Florida Geological Survey. It is hoped that in the near future the balance of the mastodon skeleton which is buried in the sand bottom of the river will be recovered so that the entire skeleton may be mounted.

<i>Tapirus sp.</i>	Tapir
<i>Mastodon americanus</i>	American mastodon
<i>Parelephas columbi</i>	Columbian mammoth
<i>Trichechus sp.</i>	Sea cow

OVIEDO, SEMINOLE COUNTY—During the summer of 1937 in digging a pit for a WPA swimming pool the workmen encountered oyster shell and clay in which were fragments of mastodon, horse and alligator. The mastodon and horse are of Pliocene genera.

<i>Alligator sp.</i>	Alligator
<i>Hipparion sp.</i>	Horse
<i>Serridentinus floridanus</i>	Fla. serrate-toothed mastodon

NORTH SHORE LAKE MONROE, VOLUSIA COUNTY—In black marl underlying Indian Shellmound at low water line fossils are washed out by wave action.

<i>Alligator mississippiensis</i>	Alligator
<i>Castor canadensis</i>	Beaver
<i>Euarctos floridanus</i>	Fla. black bear
<i>Megalonyx jeffersonii</i>	Jeffersonian ground sloth
<i>Mylodon harlani</i>	Harlan's ground sloth
<i>Holmesina septentrionalis</i>	Giant armadillo
<i>Boreostracon floridanus</i>	Fla. glyptodont
<i>Equus sp.</i>	Horse
<i>Odocoileus osceola</i>	Fla. white-tailed deer
<i>Bison sp.</i>	Bison
<i>Mastodon americanus</i>	American mastodon
<i>Parelephas sp.</i>	Mammoth

DELEON SPRINGS, VOLUSIA COUNTY—Found in Pliocene shell pit. The shell is excavated and used for road building purposes.

<i>Lamna</i> sp.	Mackerel shark
<i>Carcharodon</i> sp.	Mackerel shark
<i>Galeocerdo</i> sp.	Requiem shark
<i>Glyphis</i> sp.	Requiem shark
<i>Myliobatis</i> sp.	Eagle ray
<i>Rhinoptera</i> sp.	Eagle ray
Labrid	Wrasse fishes
Chelonian	Tortoises
<i>Carnivora</i> indet.	
<i>Proboscidean</i> indet.	

SEMINOLE SPRINGS, LAKE COUNTY—Found in the bed of Seminole Springs run. The shark and ray teeth are derived from Miocene rocks that floor the bed of the stream near its source. The Pleistocene fossils are washed in.

<i>Ginglymostoma serra</i>	Nurse shark
<i>Isurus</i> sp.	Mackerel shark
<i>Lamna</i> sp.	Mackerel shark
<i>Carcharodon</i> sp.	Mackerel shark
<i>Galeocerdo</i> sp.	Requiem shark
<i>Hemipristis</i> sp.	Requiem shark
<i>Myliobatis</i> sp.	Eagle ray
<i>Rhinoptera</i> sp.	Eagle ray
<i>Dictyodus</i> sp.	Barracudas
Labrid	Wrasse fishes
Chelonian	Tortoises and turtles
<i>Alligator</i> sp.	Alligator
<i>Equus</i> sp.	Horse
<i>Tapirus veroensis</i>	Fla. tapir
<i>Odocoileus osceola</i>	Fla. white-tailed deer
<i>Bison</i> sp.	Bison
<i>Mastodon americanus</i>	American mastodon
<i>Trichechus</i> sp.	Sea cow

LEESBURG, LAKE COUNTY—During the building of the WPA Venetian Gardens at Leesburg a hydraulic dredge was used to fill in some low land. The following were found on the fill:

Chelonian	Tortoises
<i>Alligator mississippiensis</i>	Alligator
<i>Holmesina septentrionalis</i>	Giant armadillo
<i>Parelephas columbi</i>	Columbian mammoth

ROCK SPRINGS, ORANGE COUNTY—Found in the bed of the stream. The shark and ray teeth are derived from the Miocene rock from which the spring flows. This rock also forms the stream bed near the spring.

<i>Galeocерdo sp.</i>	Requiem shark
<i>Hemipristis sp.</i>	Requiem shark
<i>Rhinoptera sp.</i>	Eagle ray
<i>Alligator mississippiensis</i>	Alligator
<i>Odocoileus sp.</i>	Deer
<i>Mastodon americanus</i>	American mastodon
<i>Trichechus sp.</i>	Sea cow

ADDITIONS TO THE RECORDED PLEISTOCENE MAMMALS FROM OCALA, FLORIDA

H. JAMES GUT
Sanford

In 1889 Leidy (1) identified a Sabre-tooth tiger, Horse, Llama, and an Elephant from a collection of teeth and bones collected by Mr. Joseph Willcox from near Ocala, Marion County, Florida in 1888. The fossils were found in a clay filled crevice exposed by quarrying operations in the Ocala limestone.

In 1916, Sellards (2) reported additional specimens collected by the Florida Geological Survey from solution channels in the Ocala Limestone near Ocala. The fossils were found imbedded in a sandy clay matrix which represented material washed in from the surface. In addition to the animals mentioned by Leidy he reported Rabbit, Armadillo, Deer, and Bison.

In 1923, Hay (3), in addition to listing all of the above, added Tapir based on a tooth that Mr. J. D. Robertson of Ocala had found in a phosphate deposit near Ocala.

In 1929, Simpson (4) reviewed the Pleistocene mammals found in or near Ocala in solution channels in the Ocala limestone. He listed all previously mentioned by Leidy, Sellards and Hay, except the Elephant recorded by Leidy. The reason for withholding the Elephant is not apparent as Leidy described and figured two teeth (1).

During the past fifteen months E. J. Moughton, Jr., of Sanford, Florida, and the writer have collected an extensive series of teeth and bones from two localities near Ocala. In both cases the specimens were found in a sandy clay matrix filling solution channels in the Ocala limestone. The most important locality is at the mine of the Dixie Lime Products Co. at Reddick, about fifteen miles north of Ocala. The other is at the Cummer Lumber Co. mine at Kendrick, about five miles north of Ocala.

This collection adds to the previously recorded mammals from near Ocala the following—Opossum, Mole, Shrew, Gopher, Mouse, Rat, Bear, Wolf, Ground Sloth, and Peccary.

TABLE 1
MAMMALS; PREVIOUSLY RECORDED, AND ADDITIONAL

Scientific name	Common name	Previously recorded	Dixie	Cummer
<i>Didelphis virginiana</i>	Opossum		X	
<i>Scalopus aquaticus</i>	Mole		X	
<i>Cryptotis floridana</i>	Shrew		X	
<i>Sylvilagus sp.</i>	Rabbit	X		
<i>Sylvilagus floridanus</i>	Fla. cotton tail	X	X	
<i>Sylvilagus palustris</i>	Marsh rabbit		X	
<i>Geomys floridanus</i>	Fla. pocket gopher		X	
<i>Peromyscus sp.</i>	Mouse		X	
<i>Oryzomys sp.</i>	Rat		X	
<i>Sigmodon hispidus</i>	Cotton rat		X	
<i>Arctodus floridanus</i> ¹	Fla. short-faced bear		X	
<i>Canis ayersi</i> ¹	Dire wolf		X	
<i>Smilodon floridanus</i> ¹	Fla. sabre-tooth tiger	X		
<i>Mylodon harlani</i> ¹	Harlan's ground sloth			X
<i>Tatu bellas</i> ¹	Armadillo	X	X	
<i>Equus leidyi</i> ¹	Horse	X	X	X
<i>Equus sp.</i> ¹	Horse		X	X
<i>Tapirus sp.</i> ¹	Tapir	X	X	
<i>Odocoileus osceola</i>	Fla. white-tailed deer	X	X	X
<i>Odocoileus sellardsiae</i> ¹	Sellard's deer			X
<i>Platygonus sp.</i> ¹	Peccary		X	
<i>Mylohyus sp.</i> ¹	Peccary		X	
<i>Tanupolana mirifica</i> ¹	Camel	X	X	
<i>Bison sp.</i> ¹	Bison	X		
<i>Parelephas sp.</i> ¹	Mammoth	X		

¹ Extinct.

BIBLIOGRAPHY

1. LEIDY, JOSEPH. "Description of Mammalian Remains from a Rock Crevice in Florida," *Trans. Wagner Free Inst. Science*, Vol. 2 (1889), pp. 13-17.
2. SELLARDS, E. H. "Fossil Vertebrates from Florida," *Fla. Geological Survey, 8th Ann. Report*, (1916), pp. 102-3.
3. HAY, OLIVER P. "The Pleistocene of North America and its Vertebrated Animals, etc.," *Carnegie Inst. of Wash. Pub. No. 322*, (1923), pp. 207 and 378.
4. SIMPSON, GEORGE GAYLORD. "Extinct Land Mammals of Florida." *Fla. Geological Survey, 20th Ann. Report*, (1927-28), p. 271.

THE ROLE OF HORMONES IN THE DEVELOPMENT OF HIGHER PLANTS

WILLIAM C. COOPER

*Bureau of Plant Industry, United States Department of Agriculture,
Orlando*

Julius Sachs, as early as 1880, clearly pointed out that the growth of plants may be influenced by "specific substances" not of the nature of foodstuffs. Twenty-five years later hormones were discovered in animals, substantiating the principal point of Sach's theory. The term hormone was derived from a Greek word meaning "I arouse to activity" and was first used by Bayliss and Starling (1) in referring to "those chemical substances secreted by the endocrine glands which, when carried by the blood stream to another organ, profoundly influence the activity of that organ."

It took another twenty-five years before botanists generally became aware of the soundness of Sach's theory, but it is clear now that plants do produce special substances which coordinate the activity of certain organs with that of others. These substances are apparently not nutrients in the ordinary sense, but rather of the nature of specific substances regulating growth.

Known chemical substances which are now regarded as plant hormones include the "auxins" and the "vitamins." In both instances the substances have been isolated from the plant tissues and appear to have a regulating effect on some physiological process in the plant. The physiological effects of these two groups of substances will be considered separately.

THE AUXINS

Isolation and identification of auxin.—A large portion of the known facts about the auxins are based on work done on the cylindrical primary leaf sheath, or coleoptile, of *Avena*. In this organ all cell divisions are completed at a very early stage, and subsequent growth consists entirely of cell elongation. If the tip of the coleoptile is cut off, the coleoptile stops growing. Paal (23) demonstrated that this is not due to a simple wound shock, for, if the tip of a decapitated coleoptile is replaced on the cut surface, the stump will grow faster than without the tip. It therefore appeared that this influence of the tip was caused by some substance diffusing out of the tip. Success in obtaining the active substance from the coleoptile

tips was finally achieved by Went (40). He placed the coleoptile tips upon blocks of agar, and then placed the agar on one side of the stumps of the decapitated coleoptiles. The result was a curvature away from the agar block (See Fig. 1). He measured this curvature, which was found to be proportional, within limits, to the concentration of the active substance. This test, "the *Avena* test," was then used to determine some of the properties of the substance which was shown to be thermostable, readily diffusible, and to have a molecular weight of about 328.

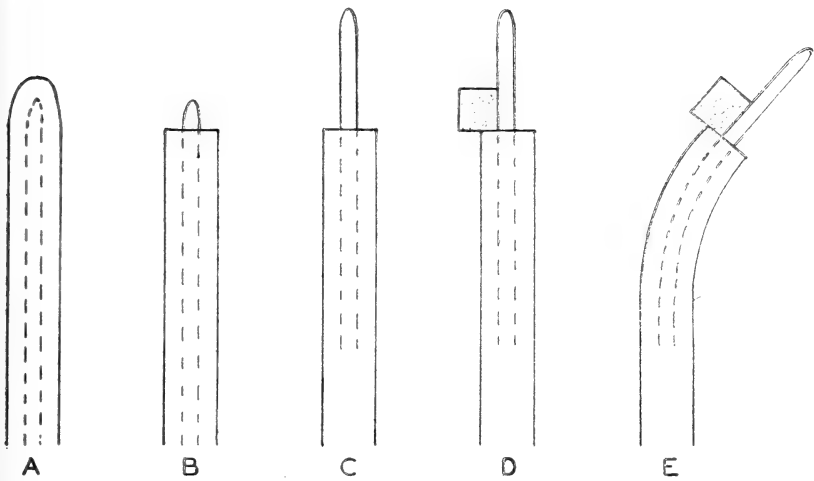

FIG. 1.—Diagrammatic summary of procedure in *Avena* test.

[Abridged from illustration by Went and Thimann (43)]

- A.—*Avena* coleoptile.
- B.—Coleoptile decapitated leaving the primary leaflet protruding above the stump.
- C.—The primary leaf partly drawn out.
- D.—Agar block with auxin placed on one side of cut surface, resting against the leaf so that it is held in place by capillarity.
- E.—Two hours after application of agar the resulting curvature is measured.

The chemistry of various substances active in the *Avena* test was worked out especially by Kögl, Haagen Smit and Erxleben (18) and Thimann (31.). Kögl and co-workers isolated three different crystalline substances, all giving positive reaction in the *Avena* test.

They have been named auxin A ($C_{16}H_{32}O_5$); auxin B ($C_{16}H_{30}O_4$); and heteroauxin (indole-3-acetic acid $C_{10}H_9O_2N$). Their chemical structure is shown in Fig. 2. Auxin A and heteroauxin were isolated from human urine and auxin B from malt and corn-germ oil. Later Thimann (31) isolated heteroauxin from *Rhizopus* cultures. Kögl and co-workers also have given good evidence by indirect methods that the active substance of the *Avena* coleoptile is auxin A. It is also probable that other plants contain the same auxin.

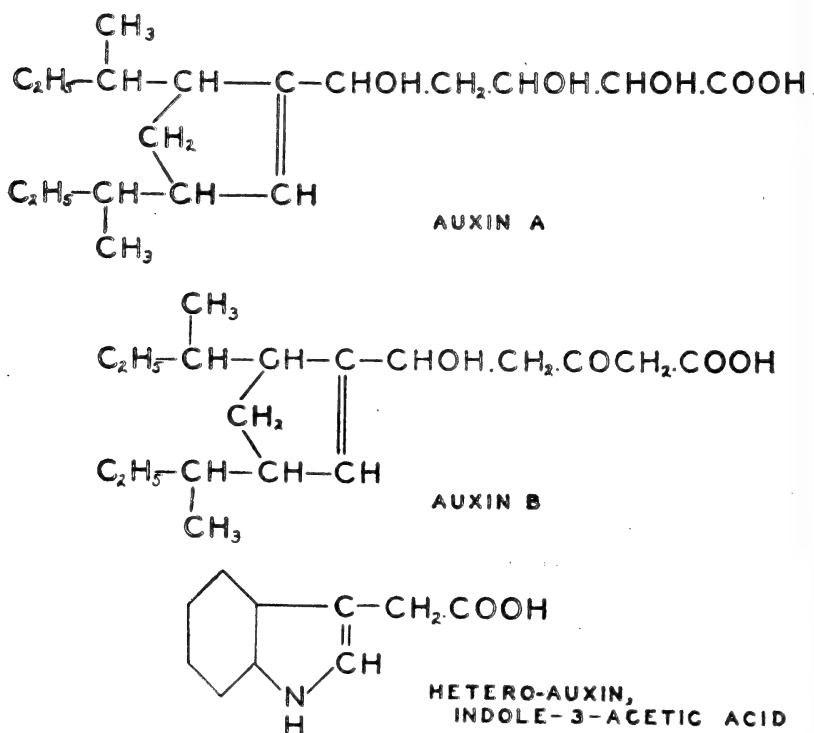

FIG. 2.—Structural formulae for the auxins.

The three auxins are physiologically indistinguishable, all of them giving the same type of growth and root production response. Also, it is now known (44) that a number of other substances, such as indolebutyric acid and naphthyl-acetic acid, affect growth and root formation in a similar way. These substances, however, have not been isolated from plant tissue.

Auxin and Growth.—Results of Went (41) with *Avena* coleoptiles, Overbeek (22) with *Raphanus* hypocotyls, and Dijkman (10) with *Lupinus* hypocotyls have shown that straight growth appears to be strictly proportional to the applied auxin up to a clearly defined limit, which limit varies for different plants. Applications of auxin beyond this limit often result in swellings, and further growth in length is inhibited.

In case of root growth, it has been shown repeatedly that certain concentrations of indoleacetic acid such as promote growth of shoots (1-10 p.p.m.) cause an inhibition of elongation of roots. It has, however, recently been made clear by Thimann (33) that in the presence of extremely dilute solutions (1/100 p.p.m.) roots of *Avena* are slightly accelerated in their growth. Grace (13) reported similar results for *Salvia*, lettuce, tomato, and nasturtium. Excellent results were also obtained from treating germinating seed with a hormone dust consisting of a dilute mixture of indoleacetic acid with talc or a standard mercurial dust disinfectant. Wheat seed treated with a 0.0002% indoleacetic acid preparation resulted in a 65% increase in the length of the roots as compared with that on non-treated seed.

Thimann and Lane (35) in a continuation of their study on the response of roots of *Avena* to auxin has found that the plant soon recovers from the inhibiting effect of a treatment with high auxin concentration. The number of roots is increased and the general vegetative growth of the shoot is accelerated. The leaves may become both longer and wider, and the dry weight of the plant may be increased more than 50 per cent.

Auxin and Root Formation.—Following the discovery of the growth-promoting activity of the auxins, it was found that many well known correlations in organ development are brought about by the same substance. Sachs (27) assumed that root formation was due to a special root-forming substance synthesized in the leaves. Proof that a special substance produced by the leaves is indeed concerned was obtained by Went (42) and the isolation of this active substance by Thimann and Went (37) led to its identification with the auxins by Thimann and Koepfli (34). This identity with the auxins has been independently confirmed by many other workers.

Study of the use of indoleacetic acid for rooting cuttings of horticulturally important plants was begun by Cooper (7). He obtained excellent root formation on cuttings of lemon, *Acalypha* and *Lantana* by application of auxin in lanolin paste form to the tip of the cutting. Later, the application of indoleacetic acid in water solution to the

base of the cuttings was utilized successfully by Hitchcock and Zimmerman (17) and by Cooper (8) for cuttings of many other plants. Subsequently numerous other workers have obtained similar results with thousands of different plants. Also Traub (38) has found that a number of substances, which are not active in the *Avena* test, are active in inducing root formation on cuttings. The furane compounds and nicotine are examples of such compounds. Later, work by Went (45) has suggested that these substances sensitize the cutting, thus more or less preparing the way for the action of the naturally occurring auxin in the cutting.

Auxin and Bud Inhibition.—Another phenomenon long known as a typical correlation is the inhibitory effect of the terminal bud of a shoot on the development of lateral buds [Goebel (12) and Reed and Halma (25)]. The lateral buds, low down on a stem, do not develop in presence of the terminal bud but if the terminal bud be removed, some of the laterals usually grow out at once; this is the basis of all pruning. Thimann and Skoog (36) were the first to demonstrate that this inhibitory influence of the terminal bud is nothing but the auxin produced by it. They removed the terminal bud and put a dosage of indoleacetic acid on the stump. The buds did not start to grow, but if the indoleacetic acid was removed the lateral bud developed. Thus it *appears* that indoleacetic acid is able to prevent buds from developing.

Auxin and Cambial Activity.—The one type of cell division which appears to be readily controlled by auxins under physiological conditions is the formation of, and division in, the cambium. Snow (29) obtained excellent cambial activity in *Helianthus* hypocotyls by application of pure auxin A and indole-3-acetic acid in concentrations comparable to that occurring in the normal plant. He produced evidence that the auxin formed by buds and leaves is responsible for the cambial activity below them.

The stimulation of cambial divisions in trees by auxin has been studied by Söding (30), who showed that insertion of a crystal of indole-3-acetic acid into the cambium of woody twigs gives rise to a rapid growth of new secondary wood. Brown and Cormack (5) also found that the application of indole-3-acetic acid in lanolin (1 p.p.m.) to the distal end of disbudded cuttings of leader shoots of balsam poplar (*Populus balsamifera*) stimulated cambial activity for a distance of 1.0—1.5 inches below the point of application.

A comprehensive study of the histological reactions of bean and tomato plants to indole-3-acetic acid has been conducted by Kraus, Brown, and Hamner (20), and Borthwick, Hamner, and Parker (4).

Seedlings were decapitated and a lanolin-indoleacetic acid mixture (2 to 3%) was applied to the cut surface. In both plants many of the tissues of the stem, in addition to the cambium, become meristematic in response to the treatment, although most of the activity was confined to a zone 0.5 to 2 mm. from the treated surface. The cells of the cortical parenchyma, endodermis, phloem parenchyma (both internal and external in case of the tomato), cambium, xylem rays, and the pith exhibited the greatest activity. Little or no meristematic activity, however, was found in the epidermis, most of the pericycle, sieve tubs, companion cells, and internal fibers.

Auxin and Parthenocarpy.—Parthenocarpy, the production of fruits without pollen, occurs naturally in a number of plants and has been induced in others by a variety of means. Recently Gustafson (14) obtained fruit development in several species, which normally do not exhibit parthenocarpy, by applying lanolin mixtures of indoleacetic acid to the styles which had first been cut off close to the ovaries. Fully developed fruits, without seeds, were obtained with tomato, *Petunia*, pepper, and eggplant. Hagerman (15) reported similar results with *Gladiolus*, and Gardner and Marth (11) produced parthenocarpic fruits on the American holly by spraying the blossoms with aqueous solutions of indoleacetic acid.

From these results and other evidence obtained by numerous workers, it appears that the pollen grain contains a growth promoting substance (probably auxin), which may be carried by the pollen tube to the ovary and cause it to grow.

Other Activities of Auxin.—A number of other effects of auxin have been recorded. These include production of root nodules on roots of leguminous plants (32), crown galls on *Phaseolus* (6), and intumescences on leaves of *Populus* (21). It has also been shown by Traub (38) that dilute solutions of either indole-3-acetic acid or indole-3-butyric acid (1-10 p.p.m.) arrested senescence in fruits of *Passiflora* and *Citrus*.

We have thus seen that the auxins play a varied role in the development of plants, and influence a large number of processes.

THE VITAMINS

Interest in the role of vitamins in plant development has centered upon the water-soluble (B and C) rather than upon the fat-soluble vitamins (A, D and E); so very little of the role of the latter is known at present.

Vitamin B₁ is of general occurrence in the tissue of higher plants, it having been found in leaves, stems, roots, fruits, seeds, etc. [sum-

mary in Sherman and Smith (28)]. The first direct demonstration that B₁ is a growth factor for higher plants was that of Kögl and Haagen Smit (19). They used excised pea embryos grown in vitro on a nutrient medium and found that added B₁ considerably improved the growth of the embryos, even in concentrations as low as 10⁻⁸. The effect in this case was primarily upon the root, the length, weight, and branching of which was considerably increased.

Bonner (2) and Robbins and Bartley (26) worked with the culture of excised roots in vitro and found that pea and tomato roots will grow in vitro in an otherwise optimal nutrient solution only if an adequate supply of B₁ is present. In other experiments with green plants, it has been demonstrated by Bonner and Greene (3) that the root is dependent upon the green leaf for its supply of this vitamin, and the growth of many green plants may be limited by a deficiency of B₁. *Aleurites*, *Buginvillaea*, *Arbutus*, *Eucalyptus*, *Camellia*, and *Bryophyllum* all showed considerably increased growth from the application of an external supply of Vitamin B₁. A similar response was obtained for papaya in the U. S. D. A. laboratory at Orlando. Furthermore, Bonner and Greene (3) have found that organic manure contains appreciable amounts of B₁ and conclude that the beneficial effects of manure upon plant development may be owing in part to its content of Vitamin B₁. The B₁ content of the soil may be expected to be derived also from plant debris and from soil microflora.

Vitamin C, also, is found generally in plant tissues. The work of Virtanen *et al.*, (39), and Ray (24) has shown that good growth of the plant was correlated with a high vitamin C content. Later, Havas (16a) was able to increase the growth rate of wheat seedlings by the addition of Vitamin C. Von Hausen (16) soaked pea seed in a concentrated Vitamin C solution, then grew the seedlings from such treated seed and found that seedlings from the treated seeds increased in dry weight 35% faster than the controls. When young plants were deprived of their cotyledons, the effect of added vitamin C was even more striking.

Vitamin B₂ is an essential part of one of the plant's oxidative mechanisms and is very widely distributed in the plant. This vitamin has a powerful growth promoting activity on young animals but no marked effect of added B₂ has been observed on the development of higher plants other than that it appears to induce germination of pollen (9).

CONCLUSION

We are now beginning to see the array of accessory growth factors which appear to be needed in minute amounts for the normal growth of the higher plants. In this brief review only the effects of known chemical substances have been considered. The existence of many other specific substances, concerned with the development of roots, leaves, flowers, etc., has been postulated, but the identity of these substances with known chemical compounds awaits further research.

BIBLIOGRAPHY

1. BAYLESS, W. M., and STARLING, E. H. "The mechanism of pancreatic secretion," *J. Physiol.*, Vol. 28 (1902), pp. 325-53.
2. BONNER, J. "Vitamin B₁ a growth factor for higher plants," *Science*, Vol. 85 (1937), pp. 183-4.
3. BONNER, J., and GREENE, J. "Vitamin B₁ and the growth of green plants," *Bot. Gaz.*, Vol. 100 (1938), pp. 225-337.
4. BORTHWICK, H. A., HAMNER, K. C., and PARKER, M. W. "Histological and microchemical studies of the reactions of tomato plants to indoleacetic acid," *Bot. Gaz.*, Vol. 98 (1937), pp. 491-519.
5. BROWN, A. B., and CORMACK, R. G. H. "Stimulation of cambial activity, locally in the region of application and at a distance in relation to a wound, by means of heteroauxin," *Can. Jour. Res.*, Vol. 15 (1937), pp. 433-41.
6. BROWN, N. A., and GARDNER, F. E. "Galls produced by plant hormones, including a hormone extracted from *Bacterium tumefaciens*," *Phytopath.*, Vol. 26 (1936), pp. 708-13.
7. COOPER, W. C. "Hormones in relation to root formation on stem cuttings," *Plant Physiol.*, Vol. 10 (1935), pp. 789-94.
8. ———. "The transport of root-forming hormone in woody cuttings," *Plant Physiol.*, Vol. 11 (1936), pp. 779-93.
9. ———. "Vitamins and the germination of pollen grains and fungus spores," *Bot. Gaz.*, Vol. 100 (1939), In Press.
10. DIJKMAN, M. J. "Wuchsstoff und geotropische Krümmung bei *Lupinus*," *Rec. trav. bot. neerl.*, Vol. 31 (1934), 391-450.
11. GARDNER, F. E., and MARTH, P. C. "Parthenocarpic fruits induced by spraying with growth-promoting compounds," *Bot. Gaz.*, Vol. 99 (1937), pp. 184-95.
12. GOEBEL, K. "Regeneration in plants," *Bull. Torrey Bot. Club*, Vol. 30 (1903), pp. 197-205.
13. GRACE, N. H. "Physiological curve of response to plant growth hormones," *Nature*, Vol. 141 (1938), p. 3557.
14. GUSTAFSON, F. G. "Inducement of fruit development by growth promoting chemicals," *Proc. Nat. Acad. Sci.*, Vol. 22 (1936), pp. 628-36.

15. HAGERMAN, P. "Über durch beta-indoleessigsäure ausgelöste parthenokarpie Gladiole," *Gartenbauwissenschaft*, Vol. 11, (1937), pp. 144-50.
16. HAUSEN, S. V. "Die Rolle des Vitamins C beim Wachstum der höheren Pflanzen," *Biochem. Zeit.*, Vol. 288 (1936), p. 378.
- 16a. HAVAS, L. "Ascorbic acid and the germination and growth of seedlings," *Nature*, Vol. 136 (1935), p. 435.
17. HITCHCOCK, A. E., and ZIMMERMAN, P. W. "Effect of growth substances on the rooting response of cuttings," *Contrib. Boyce Thompson Inst.*, Vol. 8 (1936), pp. 63-79.
18. KÖGL, F., HAAGEN SMIT, A. J., and ERXLEBEN, J. "Über ein Phytohormone der Zellstreckung," *Zeits. physiol. Chem.*, Vol. 214 (1933), pp. 241-61.
19. KÖGL, F., and HAAGEN SMIT, J. "Biotin und Aneurin als Phytohormone," *Zeitschr. Physiol. Chem.*, Vol. 243 (1936), pp. 209-26.
20. KRAUS, E. J., BROWN, N. A., and HAMNER, K. C. "Histological reactions of bean plants to indoleacetic acid," *Bot. Gaz.*, Vol. 98 (1936), pp. 370-419.
21. LA RUE, C. D. "Intumescences on poplar leaves. III. The role of plant growth hormones in their production," *Am. J. Bot.*, Vol. 23, pp. 520-4.
22. OVERBEEK, J. VAN. "Wuchsstoff, Lichtwachstumsreaktion und Phototropismus bei *Raphanus*," *Rec. trav. bot. neerl.*, Vol. 30 (1933), pp. 536-626.
23. PAAL, A. "Über phototropische Reizeitung," *Jahrb. wiss. Bot.*, Vol. 58 (1919), pp. 406-58.
24. RAY, S. "On the nature of the precursor of the vitamin C in the vegetable kingdom. I. Vitamin C in the growing pea seedling," *Biochem. Jour.*, Vol. 28 (1934), p. 996.
25. REED, H. S., and HALMA, F. F. "On the existence of a growth inhibiting substance in the Chinese lemon," *Univ. Calif. Publ. Agr. Sci.*, Vol. 4 (1919) No. 3, pp. 99-112.
26. ROBBINS, W. J., and BARTLEY, M. "Vitamin B₁ and the growth of excised tomato roots," *Science*, Vol. 85 (1937), pp. 246-7.
27. SACHS, J. "Stoff und Form der Pflanzenorgane," *Arb. bot. Inst. Wurzburg*, Vol. 2 (1880), pp. 452-88.
28. SHERMAN, H., and SMITH, S. *The vitamins*. (New York Chem. Catalogue Co., 1931).
29. SNOW, R. "Activation of Cambial Growth by pure hormones," *Nature*, Vol. 135 (1935), p. 876.
30. SÖDING, H. "Über den Einfluss von Wuchsstoff auf das Dickenwachstum der Bäume," *Ber. d. bot. Ges.*, Vol. 54 (1936), pp. 291-304.
31. THIMANN, K. V. "On the plant growth hormone produced by *Rhizopus suinus*," *J. Biol. Chem.*, Vol. 109 (1935), pp. 279-91.
32. ———. "On the physiology of the formation of nodules on legume roots," *Proc. Nat. Acad. Sc.*, Vol. 22 (1936), pp. 511-4

33. ———. "On the nature of inhibitions caused by auxin," *Amer. Jour. Bot.* Vol. 23 (1937), pp. 561-9.
34. THIMANN, K. V., and KOEFLI, J. B. "Identity of the growth-promoting and root-forming substances of plants," *Nature*, Vol. 135 (1935), p. 101.
35. THIMANN, K. V., and LANE, R. H. "After-effects of the treatment of seed with auxin," *Amer. Jour. Bot.*, Vol. 25 (1938), pp. 535-42.
36. THIMANN, K. V., and SKOOG, F. "On the inhibition of bud development and other functions of growth substance in *Vicia faba*," *Proc. Roy. Soc. B*, Vol. 114 (1934), pp. 317-39.
37. THIMANN, K. V., and WENT, F. W. "On the chemical nature of the root-forming hormone," *Proc. Kon. Akad. Wetensch. Amsterdam*, Vol. 37 (1934), pp. 456-9.
38. TRAUB, H. P. "Growth substances with particular reference to sub-tropical fruit plants," *Proc. Amer. Soc. Hort. Sci.*, Vol. 35 (1938), pp. 438-42.
39. VIRTANEN, A. V., HAUSEN, S., und SAASTAMOINEN, S. Untersuchungen über die Vitaminbildung in Pflanzen," *Biochem. Zeit.*, Vol. 267 (1933), p. 179.
40. WENT, F. W. "On growth-accelerating substances in the coleoptile of *Avena sativa*," *Proc. Kon. Akad. Wetensch. Amsterdam*, Vol. 30 (1926), pp. 10-19.
41. ———. "Wuchsstoff und Wachstum," *Rec. trav. bot. neerl.*, Vol. 25 (1928), pp. 1-116.
42. ———. "On a substance causing root formation," *Proc. Kon. Akad. Wetensch. Amsterdam*, Vol. 32 (1929), pp. 35-9.
43. WENT, F. W., and THIMANN, K. V., *Phytohormones*. (New York: The Macmillan Co., 1937).
44. ZIMMERMAN, P. W., and WILCOXIN, F. "Several chemical growth substances which cause initiation of roots and other responses in plants," *Contrib. Boyce Thompson Inst.*, Vol. 7 (1935), pp. 209-29.
45. WENT, F. W., 1939. (In Press).

TORREYA WEST OF THE APALACHICOLA RIVER

HERMAN KURZ

Florida State College for Women

INTRODUCTION

In the summer of 1936 I gave little credence to the statement of Carrie Yon Williams, a member of my Field Botany class, that *Torreya*¹ was to be found *west* of the Apalachicola River on the old Yon Plantation near Lake Ocheesee, Jackson County, Florida; for I knew that that gently rolling country was not at all like the rugged *Torreya* hills, cliffs, and ravines east of the river; moreover previous explorations in Jackson County had always shown a singular lack of many of the associates of *Torreya* of northern affinity or origin found east of the river. So, of course, Mrs. Williams must have been mistaken. Nevertheless, within a week specimens of *Torreya* came fresh from Dog Pond on the present J. W. Yon property.

PRESENT AND PAST DISTRIBUTION

Present Distribution.—Now anything new concerning the distribution of *Torreya* is of interest and importance to students of plant and animal distribution. It is not hard to account for this interest: in past geological times *Torreya* was more or less widespread throughout the Northern Hemisphere, but from the heart of this area the species vanished in geological times. The genus, because of its once greater past, its subsequent decline, and its final local last stands, has always fascinated naturalists. Today only remnant areas with four well established relic species remain: *Torreya californica* Torr. in the mountains of California; *Torreya taxifolia* Arn. in the Apalachicola River vicinity of Florida and extending a mile or so into Georgia; *Torreya grandis* Fort. in central and northern China according to Sargent,² and in eastern China according to Rehder,³ and *Torreya nucifera* Sieb. and Zucc. in

¹ Among botanists: either *Tunium taxifolium* (Arn.) Greene, or *Torreya taxifolia* (Arn.).

To the public in general: *Torreya*.

Locally: Gopherwood, Savin, Stinking cedar, or Polecat wood.

² Sargent, C. S., *Manual of the Trees of North America* (3rd Ed.; Boston and New York: Houghton Mifflin Co., 1933), pp. 1-910.

³ Rehder, Alfred, *Manual of Cultivated Trees and Shrubs*. (New York: The Macmillan Co., 1927).

Japan. Sargent² gives the Island of Quelpart as another station for *Torreya* but does not say which species. Rehder recognizes a fifth species, *Torreya Fargesii*, Franch. in central China and in western China. There is some doubt of the fifth species. But in any event great distances lie between any two of the species: *Torreya taxifolia* and *Torreya californica* are separated by a *Torreya*-less stretch of 2500 miles; from *Torreya taxifolia* eastward across the Atlantic Ocean, Europe, and Asia to *Torreya grandis* is about 8000 miles; from *Torreya californica* across the Pacific, 6000 or 7000 miles; and even the species conveniently dismissed as "Asiatic" it must be realized may themselves be great stretches apart.

Past Distribution.—According to Boeshore and Gray⁴ fossil remains of *Torreya* have been reported from Alaska (Cretaceous); Protection Island (Cretaceous); British Columbia (Cretaceous); Oregon (Eocene); California (Oligocene); Colorado (Cretaceous); Georgia (Cretaceous); North Carolina (Cretaceous); Virginia (Mesozoic); Greenland (Cretaceous and Tertiary); France (Pliocene); and Silesia (Miocene). The fact that the species once flourished over such an enormous area lends peculiar interest to the four or five species remaining in as many isolated localities.

EXPLORATION OF LOCALITY

Because of this general interest and distributional significance I explored the new location, on February 4, 1937, with the aid of Mr. Penn King who acted as guide. The area was found to be about an acre in extent and contained about sixty trees. All size classes were represented from one foot high to fifty feet high and ten inches in diameter at breast height. According to I. H. King the colony was larger in former times but clearing adjacent forest land for cultivation has reduced the stand to its present size. And even now the habitat shows signs of burning, cutting, and disturbance by hogs; yet there are seedlings of *Tumion* as well as sprouts. But unless this colony is more violently and consistently abused the species stands a fair chance of perpetuation even in this isolated and maltreated spot.

DISPOSITION OF SPECIMENS

On June 12, 1937 I made my third trip to the Dog Pond station on the J. W. Yon property. At this time I collected specimens.

⁴Boeshore, Irvin, and Gray, William D., "An Upper Cretaceous Wood: *Torreya Antiqua*," *American Journal of Botany*, Vol. 23, No. 8 (October, 1936), pp. 524-528.

Several were sent to the Herbarium of the Florida Experiment Station where they are now preserved as Specimen No. 26,668. On July 6 specimens were sent to the Herbarium of the New York Botanical Gardens and to the Herbarium of the University of North Carolina. Receipt of each of these has been acknowledged.

PREVIOUS RECORDS

Consultation of an early article by Chapman⁵ revealed that fifty-two years ago he had stated "there are, also, a few trees at the southern extremity of Cypress Lake (now Lake Ocheesee) three miles west of the river (Apalachicola River)." In fact he includes a comprehensive, distributional map with *Torreya* hatched for the south side of the southern end of the Lake as well as for the eastern bluffs and tributary streams of the Apalachicola River.

It must be pointed out that Chapman's map of Cypress Lake is far too simple, diagrammatic, and wholly inadequate to have any value in placing or locating this colony of *Torreya*. It will be noted that he hatches *Torreya* on the southern end of Cypress Lake. The map of Ocheesee Lake in the present text is by C. A. Mahan, draughtsman, after Bryan King, designer, both of the State Road Department. Mr. King is a native of the region in question and, therefore, we may consider his map of the Lake reasonably accurate. A comparison of the two maps—Chapman's and the one of this paper—shows at a glance how much Chapman was in error. The colony is actually about six miles west of the Apalachicola River and not three as stated by Chapman. Moreover, the colony is slightly to the west of the south end of Dog Pond which in turn is south of an arm projecting southward from the northwestern end of Lake Ocheesee. Since we do not know which part of the very irregularly shaped Lake Ocheesee his diagram represents, it is difficult to assert just how far his hatched area would be from the actual location of *Torreya* at Dog Pond, but it probably lies about three miles northwest of Chapman's indicated area.

In spite of considerable exploration and consultation with local residents I have as yet no verified record of *Torreya* in this vicinity except the one at Dog Pond. This fact coupled with the inaccuracy of his map and a statement quoted by Chapman elsewhere in this paper make it hard to believe that he actually saw *Torreya* at Cypress Lake. On what basis Chapman mapped the species where he did is up to the present unknown to me.

⁵ Chapman, A. W., "*Torreya taxifolia*, Arnott. A Reminiscence," *Bot. Gaz.*, Vol. 10 (April, 1885), pp. 251-254.

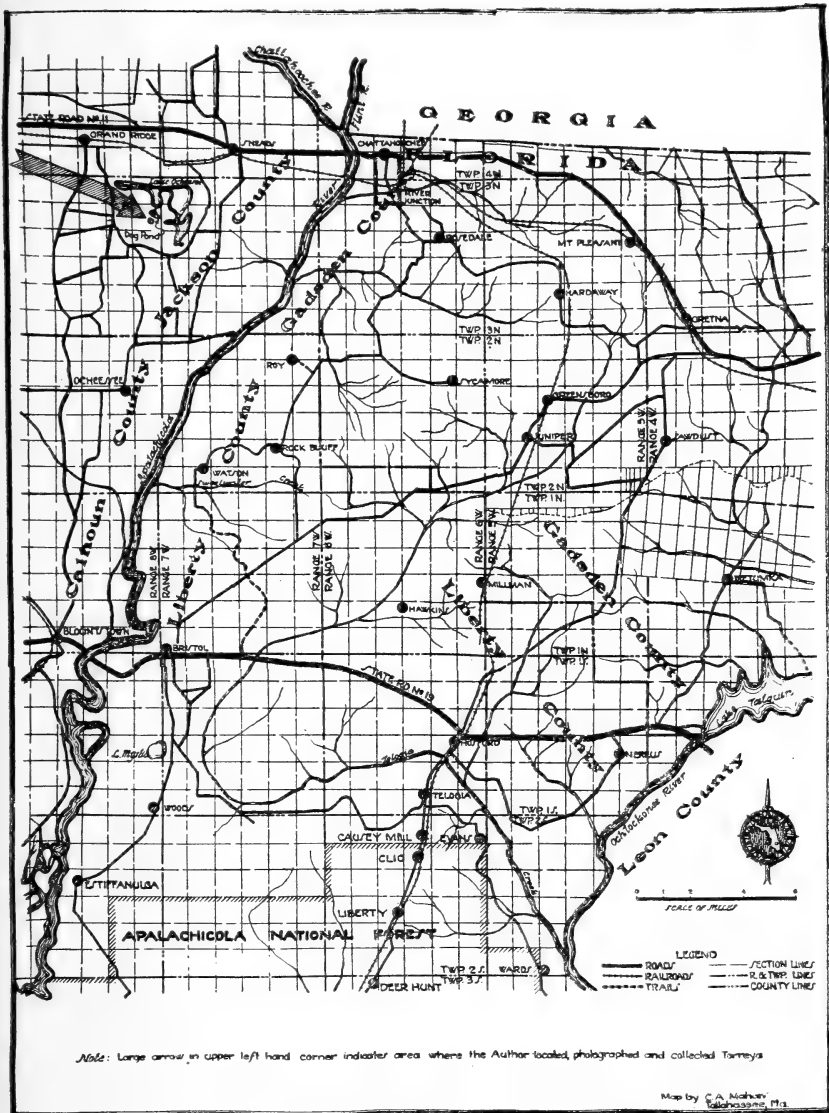

MAP SHOWING LOCATION OF LAKE OCHEESE

However, the following other considerations are also of interest. Sargent⁶ in speaking of *Torreya taxifolia* Arn., says: "Western Florida, eastern bank of the Apalachicola River from Chattahoochee to the neighborhood of Bristol, Gadsden County; doubtfully reported from the shores of a small lake west of Ocheesee and at Wakulla Springs, Wakulla County (Curtiss)." He quotes⁷ Curtiss as follows: "There are two trees in this region of particular interest, as they are not known to grow anywhere else; these are the stinking cedar (*Torreya taxifolia*) and the yew (*Taxus Floridana*). There is reason to believe that the *Torreya* occurs also along the Wakulla River, and perhaps elsewhere in the state, but there is no positive knowledge of its occurrence except along the Apalachicola River, on the limestone hills which border it at intervals on the east." While this volume was not published until 1884 Sargent wrote his manuscript as early as 1880. So just about five years before Chapman's statement and map or 1885 Sargent received but doubted the rumors of the presence of *Tumion* west of the Apalachicola River. Still more puzzling is the fact that Chapman himself confines *Torreya* to "rich soil, eastern banks of the Apalachicola River, middle Florida" in his revised book⁸ published in 1897 twelve years after his article⁹ in the *Botanical Gazette*.

A number of others have written on the restricted distribution and endemism of *Torreya*: Gray,¹⁰ Curtiss (quoted in Sargent⁷), Nash,¹¹ Cowles,¹² and Harper,¹³ All of these, tersely said, have by

⁶ Sargent, C. S., "The Forests of the United States in their Economic Aspects," *Tenth Census of the United States*, Vol. 9 (1884), p. 186.

⁷ *Ibid.*, p. 521.

⁸ Chapman, A. W., *Flora of the Southern United States*, (New York: American Book Co., 1897).

⁹ Gray, Asa, "A Pilgrimage to *Torreya*" *The American Agriculturist*, Vol. 34 (July, 1875), pp. 266-267.

¹⁰ Nash, George V., "Notes on Florida Plants II," *Torreya Botanical Club Bulletin*, Vol. 23 (1896), pp. 95-108.

¹¹ Cowles, H. C., "A Remarkable Colony of Northern Plants Along the Apalachicola River, Florida, and Its Significance," *Report of the Eighth International Geographic Congress*, (1904), p. 599

¹² Harper, R. M., "The River Bank Vegetation of the Lower Apalachicola, and A New Principle Illustrated Thereby," *Torreya*, Vol. 11 (November, 1911), pp. 225-26.

¹³ Harper, R. M., "Apalachicola River Bluff and Bottoms. Geography and Vegetation of Northern Florida," *Fla. Geol. Survey, 6th Ann. Report* (1914), pp. 210-216.

omission or commission limited the tree to a relatively narrow, irregular block of rugged topography on the east side of the Apalachicola from the Florida-Georgia line, but within Florida, to the neighborhood of Bristol. Harper,¹⁴ by discovering a few trees growing just over the Florida-Georgia state line near Chattahoochee, extended the range of *Torreya* a mile or less into Georgia. Both Sargent and Small recognize this extension by Harper. But the same authors disregard Chapman's record of isolated trees stranded near Lake Ocheese, Jackson County about six miles west of the river; Sargent² states: "On bluffs along the eastern banks of the Apalachicola River, Florida, from River Junction to the neighborhood of Bristol, Liberty County, and in the southwestern corner of Decatur County, Georgia (R. M. Harper)." Small¹⁵ says "bluffs and woods along the Apalachicola River and tributary streams." This statement of Small's, because of the omission of such terms as "eastern bank" as used by Sargent, is broad enough to cover any possible new stations of *Torreya* on either side of the river, yet Small's retention of "tributary streams" makes the statement too specific to apply to the distribution of *Torreya* west of the river, for the known disjunctive *Torreya* station west of the river is far from any tributary streams.

CONSIDERATIONS OF THE DISJUNCTIVE AREA

The strange fact that Chapman's record of these *Torreya* disjunctive outliers seems to have been consistently disregarded or overlooked for fifty-two years justifies a re-birth of his distributional statements of 1885. Hitherto the records confine *Torreya* to a more or less irregular strip of about 18 miles in length north and south and varying eastward from the river. Its eastward extension would naturally depend locally upon the size of the tributary streams and their proportional valley bluffs. The maximum would probably be under eight miles away from the river. The extension of this extremely restricted species by five or six miles is therefore in itself noteworthy; but there is still another interesting angle, and that is the freakishness of this outlying colony. Here we have on the one hand a species presumably very specific in its habitat, avoiding bluffs which appear from a vegetative, topographical, and soil aspect just a

¹⁴ Harper, R. M., *Tumion taxifolium* in Georgia," *Torreya*, Vol. 19 (June, 1919), pp. 120-2.

¹⁵ Small, J. K., *Manual of the Southeastern Flora*. (New York: Author, 1933).

continuation of the hills two or three miles farther north and eastward where it does grow; a species avoiding also a rather highly dissected area in the vicinity of Quincy, 20 miles farther east where many of its arboreal associates do grow. There is even no record of the species on the hills a mile across the river nor is it found on the natural levees adjacent to the banks east of the river which harbor many of its tree associates of the bluffs. In fact, though it does often invade the more nearly level adjacent terrain, it seldom, if ever, ventures far into the level uplands bordering the river bluffs. On the other hand the tree has moved six miles in the opposite direction across the river and established itself in an area of about one acre, on soil only a few feet above the adjacent swamp and in a locality devoid of bluffs or ravines and of the northern species associated with *Torreya* at the river.

HABITAT STUDIES

Plant Associates of Torreya.—This Apalachicola River region contains practically all arboreal species to be found in central and north Florida besides some not found elsewhere. In addition many northern species find their southernmost extension here. Cowles,¹¹ Harper,¹² and Kurz¹⁶ have pointed this out. A partial list of significant species often associated with *Torreya* follows. For comparison the commonest species found with *Torreya* at Dog Pond are also given. The nomenclature follows the usage of Small.¹⁵

TORREYA ASSOCIATES AT APALACHICOLA RIVER BLUFFS

TREES AND SHRUBS

<i>Actaea alba</i>	<i>Osmanthus americana</i>
<i>Aesculus Pavia</i>	<i>Ostrya virginiana</i>
<i>Callicarpa americana</i>	<i>Pinus glabra</i>
<i>Cercis canadensis</i>	<i>Ptelea trifoliata</i>
<i>Dirca palustris</i>	<i>Saccharodendron floridana</i> (<i>Acer</i>)
<i>Fagus grandifolia</i>	<i>Symplocos tinctoria</i>
<i>Halesia diptera</i>	<i>Taxus floridana</i>
<i>Magnolia grandiflora</i>	<i>Trillium Underwoodii</i>
<i>Oakesiella floridana</i>	<i>Tumion taxifolium</i>

¹⁶ Kurz, H., "Northern Disjuncts in Northern Florida," *Fla. Geol. Surv., 23rd-24th Ann. Report* (1933), pp. 50-53.

WOODY VINES AND HERBS

<i>Bignonia crucigera</i>	<i>Sanguinaria canadensis</i>
<i>Croomia pauciflora</i>	<i>Smilax Bona-nox</i>
<i>Dentaria laciniata</i>	<i>Syndesmon thalictroides</i> (<i>Anemonella</i>)
<i>Hepatica triloba</i>	<i>Toxicodendron radicans</i> (<i>Rhus</i>)
<i>Mitchella repens</i>	<i>Trillium lanceolatum</i>
<i>Muricauda Dracontium</i> (<i>Arisaema</i>)	

TORREYA ASSOCIATES AT DOG POND

TREES AND SHRUBS

<i>Cercis canadensis</i>	<i>Osmanthus americana</i>
<i>Fagus grandifolia</i>	<i>Ostrya virginiana</i>
<i>Halesia diptera</i>	<i>Pinus glabra</i>
<i>Ilex opaca</i>	<i>Symplocos tinctoria</i>
<i>Magnolia grandiflora</i>	

WOODY VINES AND HERBS

<i>Mitchelia repens</i>	<i>Smilax pumila</i>
<i>Anisostichus crucigera</i> (<i>Bignonia</i>)	<i>Toxicodendron radicans</i> (<i>Rhus</i>)
<i>Smilax Bona-nox</i>	

Outstanding are the facts that not one of the rare northern herbs of Apalachicola River is to be found at Dog Pond; that *Dirca* and *Taxus* are also not here. In fact except for the Magnolia-Beech forest species which are to be found anywhere in North Florida where the mesophytic climax forest exists there is nothing in the way of species that links this *Torreya* out here with the main area east of the river.

Topography and Geology.—Chapman implies that the species is confined to rugged topography: "To these cliffs, and to the precipitous sides of these ravines, the tree seems to be exclusively confined; for it is never seen in the low ground along the river, nor on the elevated plateau east of it, nor, indeed, on level ground anywhere." In considering this statement one is forced to doubt that he really saw the flat habitat of the *Torreya*s he maps for Lake Ocheesee. Sargent¹ says: "there is no positive knowledge of its occurrence except along the Apalachicola River on the limestone hills. . . ." In 1904 Cowles² wrote: "It seems likely, then, that we should regard *Torreya taxifolia* as a northern mesophytic left stranded today only in Florida. It presumably is one of the plants that failed to follow up the last retreat of the Pleistocene ice, and is preserved here perhaps

because of exceptionally favorable topographic conditions." Harper¹⁴ gives a good account of the geology, topography, hydrography, soils, and vegetation in his "Apalachicola River Bluffs and Bottoms." He lists and indicates the relative abundance of one hundred and fifty-one plants. Of the topography he writes: "The topography is everywhere hilly, and dissected by numerous ravines and small valleys, many of which end in amphitheatres or 'steepheads' at the edge of the upland." It seems evident that rugged topography is a favorable factor; it is equally evident from the Dog Pond habitat as well as from the Apalachicola River region that great relief is not imperative. Limestone as such, while favorable, must also be ruled out, for even at the river *Torreya* thrives locally where limestone is no nearer to the surface than it is locally at the Tallahassee Red Hills, fifty-six miles east, nor any nearer than it is at Marianna, twenty miles farther west.

Soils.—I took soil samples from one foot interval levels to a maximum depth of four feet, from three different *Torreya* localities, namely Alum Bluff, Aspalaga, and Flat Creek, east of the Apalachicola River and from the new Dog Pond station. There were some striking differences. The Alum Bluff samples were taken from the side of a steephead; these samples consisted predominately of coarse sand. There were, possibly due to instability, no marked zones of extraction (A-horizon), or concentration (B-horizon), and of neither extraction nor concentration (C-horizon). The Flat Creek samples on the other hand proved to be a much finer sand and the A-, B-, and C-horizons were beautifully in evidence. At Aspalaga, in glaring contrast to the two former samples, the soil consisted of clay and limestone pebbles, the rock being in places near the surface. There were no A-, B-, and C-horizons here either. At Dog Pond there were suggestions of A-, B-, and C-horizons. The soil was predominantly light chocolate colored, silty sand. A table of reaction follows:

TABLE 1
SOIL REACTIONS
(pH)

Depth	Alum Bluff	Flat Creek	Aspalaga	Dog Pond
Surface	5.5, 5.0	5.0, 5.0	8.0, 7.5, 7.5	5.0, 5.0
1 foot	4.5, 4.5	5.0	7.0	5.0
2 feet	4.5	5.0	8.0, 7.5	5.0
3 feet	5.0	4.5		5.5
4 feet	5.0	4.0		4.0

A moment's consideration of these more obvious soil characteristics leads to the disappointing conclusion that the distribution of *Torreya* either east or west of the river is not to be explained by the absence or presence of clay, sand, or humus; by the mesh size of soil particles; by definite or indefinite A-, B-, or C-horizons; nor by alkalinity or acidity.

What the modern, exceedingly delicate and precise spectrographic method of chemical analysis as applied to the soils or tissues of *Torreya* would reveal is of course of tremendous interest and importance here as well as in numerous other freakish plant distributional problems.

Geology.—A geological map by Cooke and Mossom¹⁷ shows that most of the *Torreya* region east of the river is underlaid by Tampa-limestone formation. However, *Torreya* grows several miles farther south and nearer to Bristol than this limestone reaches. The map is a generalized one and whether the limestone actually does or does not go as far south as *Torreya* awaits more careful exploration and mapping. A rapidly tapering and sinuous braid of this same Tampa is mapped across the river and westward across Jackson and into Washington Counties. That the Dog Pond colony falls within this formation is of interest. That the *Torreya*-less Tallahassee and Marianna Red Hills are not of the Tampa age is also of interest. But until we have a more detailed and accurate geological map and until the distribution of *Torreya* is more carefully worked out no conclusions having to do with *Torreya* distribution and geological formation can be drawn.

We can epitomize our habitat studies by saying that a consideration and study of topography, soils, and underlying formations give no conclusive common denominator for the main *Torreya* area east of the river and the isolated colony at Dog Pond.

Torreya parallels Taxus.—Before summarizing I should like to call attention to a similar isolation discovered for *Taxus Floridana* Nutt., a genus related to *Torreya*, and similarly endemic. This species although very much rarer than *Torreya* (forty times Harper says¹⁸) if found at all is usually with *Torreya*. Ten years ago, however, I discovered¹⁸ *Taxus* in the water-logged, acid "Johnson's Juniper

¹⁷ Cooke, C. W., and Mossom, Stuart, "Geology of Florida," *Fla. Geol. Surv., 20th Ann. Report* (1928), pp. 1-294.

¹⁸ Kurz, H., "A New and Remarkable Habitat for the Endemic Florida Yew," *Torreya*, Vol. 27, No. 5 (Sept.-Oct., 1927), pp. 90-92.

Swamp" at least eight or ten miles south and completely isolated from the mesophytic hardwood forest of the Bluffs. This isolated and strange habitat for *Taxus* had even fewer species and factors in common with the Apalachicola River Bluffs than the Dog Pond *Torreya* station. From the standpoint of present ecological knowledge no two habitats could be very much more in contrast than the mesophytic ravines of the Apalachicola River Bluffs, where the yew occurs rather sporadically, and this juniper (*Chamaecyparis thyoides*) swamp. Thus it will be seen that *Torreya taxifolia* and *Taxus Floridana* have been similarly projected from the main area of concentration and have been randomly lodged into two disjunctive spots strikingly different from each other and from the main *Torreya-Taxus* region along the river. In these latter random spots they persist for reasons now unknown.

Torreya's Habitat Prerequisites Unknown.—Statements have been and still are made that *Torreya* is restricted to steep slopes and to lime soil; that the species is waning; that it is reproducing by sprouting only; and that seldom are seedlings seen. A careful review of the environmental studies presented in this paper will disclose the fact that if *Torreya* selects any obvious factors or set of factors we have as yet been unable to ascertain just what they are.

Those who fear that *Torreya* is vanishing may be consoled by the fact that there is no evidence to that effect. Indeed if the devastation of man could be eliminated the species would in all probability be in no immediate danger. Its vegetative reproduction and many seedlings and saplings that we have seen in spite of deforestation and abuse attest that *Torreya* will require nothing for its survival except a severe letting alone.

SUMMARY

1. Chapman's long disregarded or overlooked approximate location of *Torreya* at Lake Ocheese, Jackson County across the Apalachicola River has been re-established.
2. The presence of more than sixty *Torreya* plants in this disjunct station so dissimilar to its main and long known habitat or habitats is almost as inexplicable as the disjunctive station established by me for *Taxus Floridana* in 1927. As a matter of fact, ordinary topographic features, soil peculiarities and characteristics, water, and pH relations give no clue to its habitat requirements anywhere. While it is true that *Torreya* is partial to slopes and cliffs, it is by no means confined to them.

3. The fact that *Torreya* is confined mostly to or near the Tampa formation on the east side of the Apalachicola River and also in the new station is of interest, but at present I cannot say whether this is of any significance.
4. *Torreya* produces enough sprouts and seedlings to insure its survival provided only that man let nature alone in the *Torreya* region.

ACKNOWLEDGMENTS

I am indebted to H. H. Hume, director of Research at the Florida Agricultural Experiment Station, who made a number of original papers available to me, and also to R. M. Harper, Alabama State Geologist, who furnished quotations from papers not available to me. To Mr. Bryan King of the State Road Department I am indebted for furnishing details of the outlines and localities of Lake Ocheesee and Dog Pond. I must thank Mr. Autrey C. Mahan, also of the State Road Department, for technical aid in the field and for preparation of the map.

A PHYSIOGRAPHIC STUDY OF THE TREE ASSOCIATIONS OF THE APALACHICOLA RIVER

HERMAN KURZ
Florida State College for Women

RIVER TOPOGRAPHIC FEATURES AS PLANT HABITATS

Rivers and their environs present fascinating opportunities for botanical studies. Here the nature lover usually finds many species and luxuriant plant life. One popular explanation of this abundance of species is that the water of the stream or stream system itself provides the vehicle and route for plant migration; that the seeds and fruits collected up stream are floated down the valley, favorably lodged here and there and left to germinate. Migration up the valley against the current is not considered in this explanation.

A more plausible accounting for the variety of plant life of river territory begins with a physiographic point of view. This explanation recognizes the bars, banks, natural levees, spillways or runs, oxbow lakes, flood-plains, river terraces, adjacent slopes, bluffs or cliffs, and upland, as topographic features brought about by the work of running water; it realizes, too, that each of the several physiographic features offers a distinct combination of environmental factors. One set of factors may favor or permit foothold for one association; and another set harbor a group entirely different. One situation may be too wet for some species, another may be too dry; in one place the unstable substratum may preclude some, elsewhere the very stability may bar others. Bearing in mind these differences in stability of substratum, and the extremes in soil composition and content, one can readily see why river topography is so remarkable in plant variety.

To return briefly to the problem of plant migration and distribution referred to above, plant ecologists hold that the abundance of species in the vicinity of a river depends on the great variety of conditions that running water brings about by the forces of erosion and deposition. Of course, there must be migration, but water is not the only agent of dispersal. To move seeds across land or up a hill or across country, agencies like wind, animals, and even gravity will often suffice. An important consideration in plant migration is time. In a long period of time plants can and do migrate great distances. How far they move year by year is not so important as

the number of years they have had in moving, and south of the glaciated areas this time has run into millions of years.

PREVIOUS KNOWLEDGE ABOUT THE APALACHICOLA RIVER FLORA

Because of its endemic *Torreya* (*Tumion taxifolia*) and Florida yew (*Taxus Floridana*) its flora of northern affinity, and its abundance of other species the Apalachicola River has long been a subject of much interest and a number of papers. Harper¹ has published an excellent general account of the geology, topography, hydrography, soils, and vegetations of the area in the "Apalachicola River Bluffs and Bottoms" section of his "Geography and Vegetation of Northern Florida." Listing one hundred and fifty species he relates them to such habitats as "bottoms," "banks," "bluffs," "swamps," "richwoods," and so on. Harper's work is also valuable for its references. Since Harper's publication, two papers^{2,3} have been written by the present author dealing respectively with northern disjuncts and a new station for *Torreya*. The latter paper also briefly reviews some of the former works dealing with the Apalachicola River flora.

CONCERNING THE OBSERVATIONS

In the discourse that follows the writer attempts to relate certain tree and shrub species or societies of species to the topographic features of the particular habitats that tend to harbor them. However, the reader should be informed that from the very nature of the problem it is impossible to arrive at inflexible generalizations. A number of reasons can be given. In the first place the river area shows everywhere the influence of lumbering and grazing so that the virgin forest conditions are not at hand; one can only surmise what would be, or tends to be, true by the relic trees or remnants of plant associations found here and there. Secondly, the writer is not prepared to deal with complications introduced by such catastrophic fac-

¹ Harper, R. M., "Apalachicola River Bluff and Bottoms. Geography and Vegetation of Northern Florida." *Fla. Geol. Survey, 6th Ann. Rept.* (1914), pp. 210-216.

² Kurz., H., "Northern Disjuncts in Northern Florida," *Fla. Geol. Survey 23rd-24th Ann. Report* (1933), pp. 50-53.

³ ———, "The Effect of Cold Storage on Certain Native American Perennial Herbs," these *Proceedings*, Vol. 2 (1937), pp. 36-52.

tors as fire. And finally, as any biologist knows, seldom do living things behave unconditionally according to any ironclad formula; not always do plants take advantage of or confine themselves absolutely to particular habitats that may be considered suitable for them. Nevertheless, because of the frequency with which they have been observed, certain tendencies can be stated. It really is often possible to predict that certain species or associations will be found in a specific topographic situation or habitat.

The descriptions and conclusions of the subsequent pages are based on a number of field trips to the eastern side of the Apalachicola River in the vicinity of Aspalaga, Gadsden County, and Alum Bluff, Liberty County, supplemented by a study of the east and west sides of the Chattahoochee River in the vicinity of Butler, Florida. The following river transect is, then, really a generalized and reconstructed one, representing the sum total of observations of a number of duplicate habitats or topographic features.

OBSERVATIONS

Interior Upland.—Here the erosive effect has been relatively slight. A mantle of sterile sand accumulated, or still lies, as the case may be, over the underlying clay or decomposed rock. This particular area of the transect is characterized by long leaf pine and four species of scrub oaks.

Adjacent Uplands.—The immediately adjacent upland more exposed to the erosive work of the river nearby shows clay or even partially decomposed rock outcropping, or at least near the surface. The soil here, approximating a loam, supports a red oak—white hickory—short leaf pine forest.

Unstable Slope.—A slope may locally present a variety of physiographic features. The latter in turn may be characterized by very different plants. The convex side of the curve of a stream, if the geological strata are non-resistant, is often bordered by a more or less sliding mass of clay, sand, or gravel known as a talus slope. On such a raw and creeping substratum only certain plants can exist. At Alum Bluff, for example, pines, sourwood, and wax myrtle were most prominent. Here and there seepage waters form soft, wet, and unstable habitats, where only certain species adapted to such conditions can survive. However, the very talus slope in question presents many peculiar conditions demanding more investigation.

GENERALIZED APALACHICOLA RIVER TRANSECT

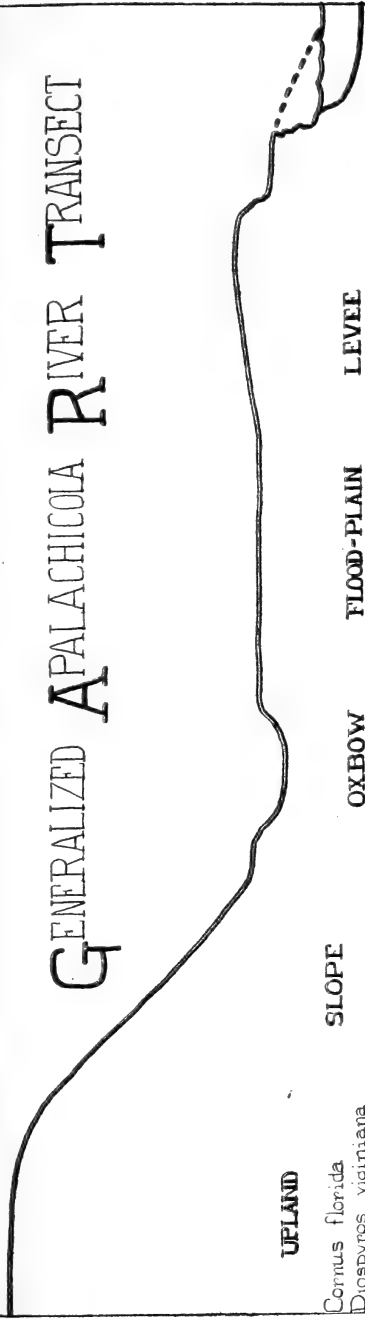

UPLAND

- Cornus florida*
- Diospyros virginiana*
- Hicoria alba*
- Nyssa sylvatica*
- Pinus echinata*
- Pinus taeda*
- Quercus laurifolia*
- Quercus stellata*
- Quercus velutina*
- Vaccinium arboreum*

SLOPE

- Dirca palustris*
 - Hydrangea cinerea*
 - Hydrangea quercifolia*
 - Torreya taxifolia*
- SPECIES OF SLOPE AND LEVEE

- Acer floridanum*
- Callicarpa americana*
- Fagus grandifolia*
- Hicoria glabra*
- Magnolia grandiflora*
- Ostrya virginiana*
- Prunus serotina*

OAK-HICKORY - PINE FOREST

BEECH-MAGNOLIA-HARD MAPLE FOREST

OXBOW

- Cephalanthus occidentalis*
- Gleditsia aquatica*
- Itea virginica*
- Nyssa ogeche*
- Nyssa uniflora*
- Planera aquatica*
- Taxodium distichum*

SWAMP FOREST

FLOOD-PLAIN

- Acer negundo*
- Carpinus caroliniana*
- Celtis mississippiensis*
- Fraxinus americana*
- Hicoria aquatica*
- Planera aquatica*
- Quercus lyrata*
- Ulmus alata*

MIXED FOREST

LEVEE

- Bumelia lycioides*
 - Halesia carolina*
 - Hicoria cordiformis*
 - Juglans nigra*
 - Ulmus fulva*
- SPECIES OF SLOPE AND LEVEE

- Acer floridanum*
- Callicarpa americana*
- Fagus grandifolia*
- Hicoria glabra*
- Magnolia grandiflora*
- Ostrya virginiana*
- Prunus serotina*

BEECH-MAGNOLIA-HARD MAPLE FOREST

RIVER BANK OR BAR

- Acer saccharinum*
- Alnus rugosa*
- Americia fruticosa*
- Betula nigra*
- Populus deltoides*

RIVER BANK OR BAR SPECIES

Rock Outcrop.—Wherever the eroding side of a stream encounters resistant rock vertical cliffs or walls of stone follow as a matter of course. At the approximate level of the channel water the rock is necessarily wetter and therefore softer. These softer rocks near the stream yield to the carving forces of the water more readily than do the higher and drier stones above. Consequently many stream cliffs show undercutting. This undercutting causes blocks of stone to topple over and to go down, or to creep away from the parent formation into isolated "chimneys" or columns. Naturally enough such rocky bluffs have their distinctive species; liverworts and certain mosses in the damper undercut roofs and walls, and other species of mosses and lichens on the drier exposed rocks or cliffs. A number of ferns, flowering herbs, shrubs, and trees may also be sought here. But the writer lacks details and can, therefore, only generalize concerning habitats of this type.

Stable Slope.—Once the stream in its wanderings recedes from a given side the slope begins to stabilize. The gradient tends to become lower and soil accumulates. Plants come in, and associations, succeeding one another over the years, will themselves enrich the soil by decay, stabilize with binding roots, and ameliorate light and water conditions by their very presence. In such a habitat we find the climax forest trees of the particular geographic or climatic region.

To explain a climax forest or vegetation thoroughly, requires considerable space. Suffice it to say that, as far as plant habitats go, there are two extremes: aquatic (hydrophytic) and dry (xerophytic). These two extremes tend to become more moderate. Hydrophytic bodies of water gradually fill up and become less hydrophytic, and dry exposed places tend to wear down and gain more water. That is, both extremes in topographic features tend to approach a common goal where water conditions are medium. Along with these physiographic, water, and air conditions there come succeeding changes in plant personnel. Hydrophytic aquatic species ultimately yield to those requiring less water and xerophytic species give way to those requiring more water and less light, so that ultimately a filled up pond or worn down rock will be inhabited or dominated by species peculiar to or requiring conditions medium as to water, temperature, and light, and a mellow, well aerated soil rich in minerals and humus. In northern Florida, beech and magnolia, or beech, magnolia and Florida hard maple form the dominant climax forest species with an occasional smooth hickory, black cherry or American ash.

Subordinate species of such a climax are the ironwood, a small tree, and French mulberry, a shrub. There are, of course, typical

herbs and vines, too; and if the association is disturbed, a great number of other trees and shrubs may come in as impurities, especially in clearings. The spruce pine is often found in such areas. It is interesting to note that on the stable portion of the slope in our river transect a number of interesting herbs, shrubs, and trees are often associated with or near the climax forest species. The endemic *Torreya*, the leatherwood of the far north, and the northern disjuncts referred to in the introduction are to be found in these more or less stable slopes.

Here and there resistant stone has stood against the wear and tear of the ages. These rocky outcrops, removed from the ravages of the flood water and made moist, cool, and shady by seepage waters and a forest canopy, produce plant habitats which are in striking contrast to the exposed rock masses of the river front. The latter at times may locally be extremely dry, hot, or cold and intensely lighted. These protected rock or cliff relics of the climax forest slope offer a congenial habitat for many species of liverworts, mosses, ferns, some flowering herbs, hydrangeas and still others.

Oxbows.—Not uncommonly meandering streams cut new channels across the neck of the loop. The abandoned loop may now become an oxbow lake with more or less permanent water. Just how permanent or deep the water of such a lake is depends of course on a number of other subsequent physiographic developments. In any event these oxbows, too, have their peculiar species. Here thrive tupelo gum, ogeche gum, bald cypress, red maple, plane tree, water ash, Virginia willow and now and then a water honey locust. The age of the oxbow, frequency of flooding, and permanence of water, all enter in determining the species, but as yet we make no attempt to correlate the species listed with particular stages, ages, or kinds of oxbow lakes.

Flood-plain Proper.—The writer uses this phrase for that part or those parts of a flood-plain that can not be definitely called an oxbow, levee, spillway or run, or bar. The flood-plain proper really comprises most of the river swamp. There we find all kinds of local variations. Some areas are often flooded, and others seldom flooded. Regions of erosion and regions of deposition occur alternately. In one place or level there may be clay or sand; in another, silt or gravel. The flood-plain proper is therefore a locality of great instability, making foothold or rooting difficult for some plants, and making it hard for others to keep heads or tops above flood water. Relatively few perennial herbs can adapt themselves to such periodic

violence. On the other hand, the variety of sub-stratum conditions, the abundance of water along with the new soils that floods bring from time to time, favor a mixed forest luxuriant of growth and abundant in arboreal and climbing species. Even though almost all the species found in the levees, oxbows, or even river banks or bars, may stray anywhere into the flood plains, hackberry, cork elm, water beech, overcup oak, water hickory, walnut, and box-elder may be considered typical. In places the flood-plain will be marked by spillways or runs from the overflowing channel. At the recession of the flood the water returns to the channel by those very runs. The spillways, unstable and often loaded with sand, offer difficulties for plant establishment, but species like sycamore, silver maple, cottonwood, are often found in them.

Levee.—When a stream overflows, it deposits the greater part of its load at or near the rim, building up in this way a natural levee which parallels the channel at the rim. The buried buttresses of the trees attest to this accumulation of sand and silt from over-flowing streams.

The levee may be only a few feet higher than the flood-plain proper; yet this slight elevation, together with the better drainage afforded by the nearness of channel wall, creates a habitat which in environmental factors approaches climax forest conditions. We discover here a reappearance of the dominant climax forest trees of the stable slope—beech, magnolia, Florida hard maple, ironwood, white hickory, redbud, spruce pine, and holly might be mentioned.

Besides these climax trees, there are other species like buckthorn, bitter-nut, hickory, slipper elm, catalpa, smooth sumac, all of which might be considered typical of levees. Then, too, there are some species on the levee that are also common to flood-plain proper. The levee situation offers an interesting illustration of the importance of little niceties in determining plant distribution. This habitat, only a few feet higher than the interior flood-plain, provides conditions just suitable for climax forest trees. On the other hand the violence of occasional flooding or other conditions of the levee seem to preclude establishment of such concomitant species of these climax trees as, for example, *Torreya*, and leatherwood. Along with this perplexing nicety there is here an almost startling illustration of the important role physiography plays in determining the species content or complex of plant associations.

River Bar.—On the concave side of the curve of the stream, because of the lower velocity, the running water deposits its load and

forms a bar of sand or mud. A bar represents new land or habitat for plants. The pioneer species of trees encountered here are black willow, cottonwood, silver maple, alder, sycamore, riverbirch and lead plant. From time to time the river floods the bar and builds it up higher and higher so that eventually it is characterized by a relatively greater stability, with consequent less frequent inundation and more of the species of interior flood-plain.

River Bank.—Very frequently a stream confines its meandering course within its own flood-plain. In such case the convex side of the curve may be considered a river bank. From a vegetational point of view such a topographic feature is most catastrophic. Practically all we ever see here are toppling trees and exposed roots. Retrogression and destruction are the rule. The species or individuals present on such a river bank are those that persist in spite of, not because of the conditions.

SUMMARY

1. River systems are marked by many types of topographic features. The latter in turn are responsible for a great variety of plant habitats. The sum total of all these habitats rather than stream migration accounts for the abundance of species and locally luxuriant river vegetation.
2. The Apalachicola River area is notable for its variety of species, endemic *Torreya*, Florida yew, and for its northern disjuncts.
3. This is the first attempt to show the influence of the topographic features of the Apalachicola River on the character of its tree associations. In this connection it is important to note that the slightly higher elevation, (really only a few feet) of the levee causes a re-appearance of certain climax forest trees there.

TABLE 1
DISTRIBUTION OF SPECIES

Habitat	Total no. of species in habitat	No. of species in only 1 habitat
Upland	27	12
Slope	43	13
Oxbow	12	2
Flood-plain	36	4
Levee	29	3
River bank, bar	11	2

TABLE 2

REPETITION OF SPECIES
(not repeated in other habitats)

	Upland	Slope	Oxbow	Flood-plain	Levee	River bank, Bar
Upland	15	10		5	5	3
Slope		20	2	14	14	1
Oxbow			8	6	2	4
Flood-plain				7	5	1

APALACHICOLA RIVER SPECIES

UPLANDS (27 species)

<i>Asimina angustifolia</i>	Dog pawpaw
<i>Batodendron arboreum</i>	Sparkleberry
<i>Callicarpa americana</i>	French mulberry
<i>Cercis canadensis</i>	Redbud
<i>Cornus florida</i>	Dogwood
<i>Diospyros virginiana</i>	Persimmon
<i>Hamamelis virginiana</i>	Witch hazel
<i>Hicoria alba</i>	White hickory
<i>Hicoria glabra</i>	Smooth hickory
<i>Liquidambar styraciflua</i>	Sweet gum
<i>Nyssa sylvatica</i>	Upland gum
<i>Pinus echinata</i>	Short leaf pine
<i>Pinus palustris</i>	Long leaf pine
<i>Pinus taeda</i>	Old field pine
<i>Pyrus angustifolia</i>	Crab apple
<i>Quercus alba</i>	White oak
<i>Quercus catesbaci</i>	Turkey oak
<i>Quercus cinerea</i>	Upland willow oak
<i>Quercus laurifolia</i>	Laurel oak
<i>Quercus margaretta</i>	Small post oak
<i>Quercus marylandica</i>	Black jack oak
<i>Quercus ruba</i>	Red oak
<i>Quercus stellata</i>	Post oak
<i>Quercus velutina</i>	Black oak
<i>Rhus copallina</i>	Sumac
<i>Viburnum rufidulum</i>	Southern black haw
<i>Zanthoxylum clava-herculis</i>	Prickly ash

SLOPE (43 species)

<i>Acer carolinianum</i>	Red maple
<i>Acer floridanum</i>	Florida hard maple

<i>Aesculus pavia</i>	Red buckeye
<i>Aralia spinosa</i>	Devil's club
<i>Arundinaria tecta</i>	Reed
<i>Asimina parviflora</i>	Pawpaw
<i>Batodendron arboreum</i>	Sparkleberry
<i>Callicarpa americana</i>	French mulberry
<i>Carpinus caroliniana</i>	Water beech
<i>Cercis canadensis</i>	Redbud
<i>Cornus florida</i>	Flowering dogwood
<i>Cornus stricta</i>	Dogwood
<i>Dirca palustris</i>	Leatherwood
<i>Euonymus americana</i>	Strawberry bush
<i>Fagus grandifolia</i>	Beech
<i>Fraxinus caroliniana</i>	Water ash
<i>Halesia diptera</i>	Silver bell
<i>Hamamelis virginiana</i>	Witch hazel
<i>Hicoria alba</i>	White hickory
<i>Hicoria aquatica</i>	Water hickory
<i>Hicoria glabra</i>	Smooth hickory
<i>Hydrangea cinerea</i>	Ash-hydrangea
<i>Hydrangea quercifolia</i>	Oak-leaved hydrangea
<i>Ilex opaca</i>	American holly
<i>Juniperus virginiana</i>	Red cedar
<i>Liriodendron tulipifera</i>	Tulip poplar
<i>Magnolia grandiflora</i>	Magnolia
<i>Magnolia pyramidata</i>	Wood-bread
<i>Morus rubra</i>	Red mulberry
<i>Nyssa sylvatica</i>	Upland gum
<i>Nyssa biflora</i>	Water gum
<i>Osmanthus americana</i>	Wild olive
<i>Ostrya virginiana</i>	Ironwood
<i>Pinus glabra</i>	Spruce pine
<i>Platanus occidentalis</i>	Sycamore
<i>Prunus caroliniana</i>	Cherry laurel
<i>Ptelea trifoliata</i>	Wafernut
<i>Quercus lyrata</i>	Overcup oak
<i>Quercus alba</i>	White oak
<i>Quercus prinus</i>	Cow oak
<i>Quercus shumardii</i>	Leopard oak
<i>Rapidophyllum hystrix</i>	Needle palm
<i>Sebastiania ligustrina</i>	Sebastian bush
<i>Tilia heterophylla</i>	Linden
<i>Torreya taxifolia</i>	Torreya
<i>Viburnum rufidulum</i>	Southern black haw
<i>Viburnum semitomentosum</i>	Haw

OXBOW (21 species)

<i>Acer carolinianum</i>	Red maple
<i>Amorpha fruticosa</i>	Indigo bush
<i>Catalpa catalpa</i>	Catalpa
<i>Cephalanthus occidentalis</i>	Buttonbush
<i>Fraxinus caroliniana</i>	Water ash
<i>Gleditsia aquatica</i>	Water locust
<i>Nyssa ogeche</i>	Ogeechee plum
<i>Nyssa aquatica</i>	Tupelo gum
<i>Platanus occidentalis</i>	Sycamore
<i>Populus deltoides</i>	Cottonwood
<i>Quercus obtusa</i>	Water oak
<i>Salix nigra</i>	Black willow
<i>Taxodium distichum</i>	Bald cypress

FLOOD PLAIN (36 species)

<i>Acer carolinianum</i>	Red maple
<i>Acer negundo</i>	Box elder
<i>Amorpha fruticosa</i>	Indigo bush
<i>Betula nigra</i>	River birch
<i>Bumelia lycioides</i>	Buckthorn tree
<i>Callicarpa americana</i>	French mulberry
<i>Carpinus caroliniana</i>	Water beech
<i>Catalpa catalpa</i>	Catalpa
<i>Celtis mississippiensis</i>	Hackberry
<i>Diospyros virginiana</i>	Persimmon
<i>Fraxinus americana</i>	American ash
<i>Fraxinus caroliniana</i>	Water ash
<i>Gleditsia aquatica</i>	Water locust
<i>Halesia diptera</i>	Silver bell
<i>Hicoria aquatica</i>	Water hickory
<i>Ilex decidua</i>	Holly
<i>Ilex opaca</i>	American holly
<i>Juglans nigra</i>	Black walnut
<i>Juniperus virginiana</i>	Red cedar
<i>Liquidambar styraciflua</i>	Sweet gum
<i>Liriodendron tulipifera</i>	Tulip poplar
<i>Morus rubra</i>	Red mulberry
<i>Nyssa ogeche</i>	Ogeechee-plum
<i>Nyssa aquatica</i>	Tupelo gum
<i>Pinus glabra</i>	Spruce pine
<i>Planera aquatica</i>	Planetree
<i>Platanus occidentalis</i>	Sycamore
<i>Populus heterophylla</i>	Cottonwood
<i>Quercus laurifolia</i>	Laurel oak
<i>Quercus lyrata</i>	Overcup oak

<i>Quercus nigra</i>	Water oak
<i>Quercus obtusa</i>	Water oak
<i>Quercus pagoda</i>	Spanish oak
<i>Quercus prinus</i>	Cow oak
<i>Sabal minor</i>	Blue stem palm
<i>Sebastiania ligustrina</i>	Sebastian bush
<i>Taxodium distichum</i>	Bald cypress
<i>Ulmus alata</i>	Cork elm

LEVEE (29 species)

<i>Acer floridanum</i>	Florida hard maple
<i>Acer negundo</i>	Box elder
<i>Callicarpa americana</i>	French mulberry
<i>Carpinus caroliniana</i>	Water beech
<i>Catalpa catalpa</i>	Catalpa
<i>Cornus florida</i>	Flowering dogwood
<i>Cornus stricta</i>	Dogwood
<i>Fraxinus americana</i>	American ash
<i>Halesia carolina</i>	Silver bell
<i>Halesia diptera</i>	Silver bell
<i>Hicoria aquatica</i>	Water hickory
<i>Hicoria cordiformis</i>	Bitter-nut
<i>Hicoria glabra</i>	Smooth hickory
<i>Ilex opaca</i>	American holly
<i>Juglans nigra</i>	Black walnut
<i>Liquidamber styraciflua</i>	Sweet gum
<i>Magnolia grandiflora</i>	Magnolia
<i>Ostrya virginiana</i>	Ironwood
<i>Pinus glabra</i>	Spruce pine
<i>Pinus taeda</i>	Old field pine
<i>Planera aquatica</i>	Plane tree
<i>Ptelea trifoliata</i>	Wafer-nut
<i>Quercus lyrata</i>	Overcup oak
<i>Quercus nigra</i>	Water oak
<i>Quercus prinus</i>	Cow oak
<i>Rhus glabra</i>	Smooth sumac
<i>Sebastiania ligustrina</i>	Sebastian bush
<i>Taxodium distichum</i>	Bald cypress
<i>Ulmus alata</i>	Cork elm
<i>Ulmus fulva</i>	Slippery elm

RIVER BANK OR BAR (11 species)

<i>Acer saccharinum</i>	Silver maple
<i>Alnus rugosa</i>	Alder
<i>Anorphy fruticosa</i>	Indigo bush
<i>Betula nigra</i>	River birch

<i>Diospyros virginiana</i>	Persimmon
<i>Liquidamber styraciflua</i>	Sweet gum
<i>Platanus occidentalis</i>	Sycamore
<i>Populus deltoides</i>	Cottonwood
<i>Quercus rubra</i>	Red oak
<i>Salix nigra</i>	Black willow
<i>Taxodium distichum</i>	Bald cypress

PRETENDED ACCURACIES IN COMPUTATIONS

B. P. REINSCH
Florida Southern College

INTRODUCTION

In our day and age, in which Michelson measures the length of the standard meter to within an error of less than one in two million, it has become the vogue to think of scientific measurements and computations as uncannily precise and accurate. It may be proper, therefore, to call attention to, and make an analysis of, certain pretended accuracies in mathematical computations with measured quantities found in the various technical periodicals and text books. In all the fields of science where mathematical computations are made (physics, chemistry, biology, hydraulics, strength of materials, etc.), wrong notions of accuracy are prevalent to an unbelievable degree.

PRELIMINARY IDEAS

To keep this paper from being too technical, the discussion will be based on a few very simple ideas, namely:

1. The nature of a physical measurement. All measurements are only approximate. When we say that the length of a rod is measured to be 3.6 inches we mean to say that its true length lies somewhere between 3.55 inches and 3.65 inches. The error in the measurement of 3.6 inches may therefore be as large as .05 inch. This measurement is said to be accurate to the nearest two significant figures. For simplicity we shall omit the consideration of measurements in which the error may be even greater.
2. The idea of *number of significant figures*. For example, each of the following numbers represents a measurement correct to the nearest three significant figures: 84200, .0346, .0000205, .0200, 6.00.
3. The accuracy of a measurement is indicated, in the number representing it, by the *number of significant figures* and *not* by the number of decimal places. This is easily seen in the following illustrations: .000024 Km. = .024 m. = 2.4 cm. = 24 mm. = 24000 mikrons. Here each measurement is obviously correct only to the nearest two significant figures.

4. In computing with measured quantities the result is in general never more accurate than the least accurate measured quantity used in the computation. Let us give a simple illustration. The area of a rectangular field, 2163.18 ft. by 1.27 ft., is computed by multiplication to be 2747.2386 sq. ft. How accurate is this? By considering the true nature of the measurements we see that the correct area lies somewhere between the values

$$\begin{aligned} (2163.175) (1.265) &= 2736.416 \quad \text{and} \\ (2163.185) (1.275) &= 2758.061 \end{aligned}$$

or, rounded off to the nearest three significant figures, somewhere between 2740 and 2760. We see from this that the original product (representing the area) is not accurate to more than three figures, which is the accuracy of the least accurate factor, 1.27. The product is not even correct to the nearest three significant figures.

This general principle is also true for divisions and other more complicated computations. An extensive theory of errors and percent errors gives more information, but it will not be used in this paper.

DESCRIPTION OF VARIOUS TYPES OF ERRORS

Most frequently encountered is:

1. The error of carrying out results to an accuracy incompatible with the accuracy of the data.

Illustrations from various sources follow. In a recent number of *Industrial and Engineering Chemistry*¹ we find the computation,

$$.066395 \times .00282 \times 5963.7 = 1.1166$$

and the statement "this result checks [!] the figure 1.117 used in the formula." Since the number .00282 is correct to only 3 significant figures, the computed result would be reliable to no more than 3 figures, namely, 1.12. How can the author then say that this checks the figure 1.117, to four figures?

In this same issue we find the computation

$$\frac{1.0054}{0.998} = 1.0074$$

Three figure data, yet results pretending to be accurate to five figures! The result should have been given as 1.01, known to the nearest 3 figures only.

¹ Vol. 10 (Jan. 15, 1938), p. 11.

In a famous text on thermodynamics we find

$$\begin{aligned} & \text{"Weight of Fuel Mixture required per minute} \\ & = \frac{(42.44) (80)}{(0.83) (205)} = 19.95 \text{ lb.}" \end{aligned}$$

Here a part of the data is correct to only 2 figures, the factor 0.83 representing the highly uncertain value of the mechanical efficiency of the engine. Hence, the result should be given to no more than 2 figures (20 lbs.)

In a text on mechanics for engineers we find the problem "Find the work done in raising 100 tons of ore from a mine shaft 1500 ft. deep, hoisting apparatus having total efficiency of 45%." The answer is given as 666 666 667 ft. lbs. !

This is a classic! Such an accuracy in the computed result would require the load of ore to be measured to the nearest one-thousandth of a pound, and the depth of the mine shaft correct to the nearest one-ten thousandth of an inch!

In the same text the kinetic energy of a rotating flywheel is computed to five figures,

$$\text{K.E.} = \frac{1}{2} I \omega^2 = \frac{1}{2} (1000/32.2) (2)^2 (20.94) = 27234 \text{ ft. lbs.},$$

even though the value of the acceleration of gravity ($g=32.2$) is given to only three figures.

Similar errors are found throughout the textbooks in the applied sciences of mechanics, strength of materials, hydraulics, thermodynamics, etc. These simple errors are unbelievably frequent. In fairness we must say that some authors are very accurate, but the sad fact remains that only rarely does one find a textbook in the applied sciences that does not contain such silly mistakes.

Who is responsible for all of this? Who taught these writers how to make such ridiculous computations? Evidence will now be given showing that the college textbooks in the basic computational sciences (physics, chemistry, and mathematics) encourage these practices and actually teach these in their illustrative problems.

In a recent excellent textbook in physics, we find an illustrative problem computing the pressure of a column of mercury 76 cm. high at 0° C to seven figures with data given to only two and three figures:

$$P = 76 (13.6) (980) = 1\ 012\ 928 \text{ dynes/cm.}^2.$$

In a general chemistry text the author uses three-figure data to obtain a result to six figures:

$$V_s = \frac{750 \times 10 \times 273}{760 \times (273+20)} = 9.19 \text{ liters,}$$

then $9.19 \times 1.429 = 13.1325$ g. oxygen.

In a college trigonometry text we find the problem:

"The Star Sirius is 5.26×10^{13} miles distant. How long will it take light to travel from the star to us at 186,000 mi. per second?"

The data are given to only 3 figures, yet the answer is given to 5 figures: *Ans.* 3254.4 days.

So far we had only illustrations of carrying out computations to an accuracy incompatible with the accuracy of the data.

Other types of pretended accuracies and undesirable practices are now listed:

2. Problems are given with data appearing to be measured quantities, yet computations are made as if the data were exact.

Illustration from a mathematics text:

$$X = 32.2 (2.6)^{-2} = \text{-----} = 4.7634$$

$$X = \left(\frac{93.5}{3.1} \right)^{1.3} = \text{-----} = 83.807$$

3. Answers pretend to be exact when they are not—can not be exact.

Illustration. The volume of a silo with inside diameter

= 20 ft. height = 12 ft. (using $\pi = 22/7$) is

$$V = \pi R^2 h = 22/7 (10)^2 (12) = 3771 \frac{3}{7} \text{ cu. ft.}$$

4. Many texts, when working with 4—place logarithm tables, always keep 4 figures in the answers, and never mention the fact that the fourth figure is usually considerably in error.
5. When approximate values are substituted for the various irrational and transcendental quantities, they are not taken accurately enough. That is, errors are introduced into the result due to the insufficiently accurate values of the rounded-off values of quantities like

$$\pi \sqrt{2}, \sin 40^\circ, \log 1.05$$

6. Data are sometimes given to an improbable or even impossible degree of accuracy.
7. Problems involving physical constants are often carried out too far. This is frequently done in the kinematics and dynamics problems of mechanics involving the value of acceleration of gravity, $g = 32.2$. Similarly in problems involving densities, specific gravities, or atomic weights.

HOW FREQUENT ARE THESE ERRORS?

Some texts are literally filled with them while others contain very few. They really shouldn't contain any such errors. It must be noted also that some texts have few if any illustrative numerical computations. A check of *eleven* recently published texts in college physics showed *nine* of them to contain such errors. A random examination of *twelve* chemistry texts, that contained numerical computations, showed that *eight* contained such errors. Out of *forty-two* freshman mathematics texts, *twenty-nine* had such errors. Examination of *nineteen* most recently published texts in high school mathematics showed *seventeen* with such errors.

The implications are profound and strange. The errors involve such simple and elementary ideas, that a well-instructed freshman will not only immediately detect them, but not make them himself. Yet these same errors are being made by college professors in the physical sciences and mathematics, men with the degree of Doctor of Philosophy, heads of departments, men listed among the American Men of Science. Think of the enormous amount of time being wasted in making these uselessly accurate computations. Of more serious consequence, consider the deception. To encourage or permit students to believe that they have computed, for example, the weight of a barrel of water to the nearest one-hundredth pound, when the result is not even correct to the nearest pound, is, no doubt, one of the greatest intellectual frauds in education today.

HOW CAN THE GREAT FREQUENCY OF THESE ERRORS BE ACCOUNTED FOR?

Traditionally, the subject has received very little systematic attention or instruction. It has possibly been considered too elementary. It has been taken for granted that students can see and learn these principles by themselves. Not enough attention has been given to the approximate character of *all measurements* of length, time, mass

and the approximate character of all computed results based on these measurements.

Certain recent texts deserve great praise for giving treatments on approximate computations—but they don't go far enough. They don't incorporate these ideas throughout the text; they don't give enough practice.

SOME PROPOSALS FOR CORRECTING THE SITUATION

1. Wherever possible, discuss accuracy of results. This is just as important as the checking of results.
2. Do not give problems with *exact* data only (these are really unnatural) but also give approximate data—data representing actual measurements. Most problems are too idealistic. We need some of these, of course, to illustrate general principles.
3. Insert more illustrative problems showing actual treatment of:
 - (a) computations with approximate data,
 - (b) rounding off results,
 - (c) deciding on the accuracy of results.
4. Insert problems asking the student to investigate the effects upon the results of given errors in the data.
5. All teachers of basic sciences should make a serious study of the theory of measurements² and computations with measured quantities.
6. Have the students find errors in the texts. Have them make criticisms of the authors. Nothing helps more to create confidence in the student than for him to be able to show that some man of science has done something ridiculous.
7. Introduce and use the symbol \approx (approximately equal to) in contrast with the symbol $=$ (equal to).
8. Devote some actual lesson time to the study of the theory of measurement, and computation with approximate quantities, before extended computations are taken up in the course. Time spent on this will not be lost, but, on the contrary, will pay big dividends.
9. Whenever such errors are found in new textbooks make complaint to both author and publisher.

² Two excellent references are:

Scarborough, J. B., *Numerical Mathematical Analysis*. (Baltimore: The Johns Hopkins Press, 1930).

Twelfth Yearbook of the National Council of Teachers of Math. (New York: Bureau of Publications, Teachers College, Columbia University, 1937).

THE NECESSITY FOR ARTESIAN WATER CONSERVATION IN THE FLORIDA PENINSULA

SIDNEY A. STUBBS
University of Florida

We are often prone to think of water in the same terms in which we think of air and sunshine, an unlimited supply to be used or wasted as we see fit. Such is not the case, as I shall attempt to demonstrate.

The artesian water supply of Florida is by far its richest natural resource, both from an agricultural and industrial viewpoint. Untold millions of gallons are used yearly in the raising and processing of truck crops, in the citrus, the phosphate and the pulp industries. Even a great many of the attractions for our winter visitors, such as tropical springs and cultivated gardens, depend upon the artesian waters of the state. Most of our towns and cities use artesian water as a municipal supply.

Underlying the peninsula of Florida there is a vast natural reservoir. This reservoir serves as a storage basin, and like all reservoirs has a limited capacity, the exact measure of which is a physical impossibility. This reservoir is largely filled with unusable saline waters. By unwise draft on the fresh water within this storage tank, this saline water will encroach upward and reduce the fresh water capacity to such an extent that eventually the usefulness of the reservoir will be destroyed.

The artesian water supply of Florida is of course conditioned by the geology of the state. The Florida Peninsula is underlain by several thousand feet of sedimentary rocks resting upon a basement of metamorphic rocks. The age of these sediments goes back into the Upper Cretaceous; but our artesian waters are obtained from only a part of the Eocene, Oligocene and Miocene formations which constitute a comparatively few hundred feet of the accumulated thickness.

The most important of these aquifers are the Coskinolina Zone and the Ocala limestone of Eocene age. Both of these are relatively soft, porous limestones, very susceptible to solution activity, and as a consequence are literally cut to pieces by a ramifying maze of underground channels and caverns. Limestones of this nature are extremely pervious and allow the free passage of underground waters. For this reason they form ideal aquifers.

Oligocene deposits within the Peninsula are limited to a portion of northern Florida adjacent to the Suwannee river, and are therefore of very minor importance as artesian aquifers.

The Tampa limestone and the Hawthorn formation of Miocene age have been rather extensively developed for artesian water. Water from the Tampa limestone is usually of good quality, but the areal extent of that formation is limited. In 1933, research initiated by A. P. Black at the University of Florida established the fact that fluorine is present in some underground waters of Florida in objectionable quantities. Subsequent investigation by the State Geological Survey showed that these fluorine-bearing waters are coming largely if not entirely from the Hawthorn formation. For that reason it seems desirable at present to preclude the Hawthorn formation as an aquifer, especially if the water is to be used for domestic purposes. Experiments are now being carried out under the direction of Dr. Black to determine whether fluorine in waters used for irrigation is transmitted to the plants irrigated.

The most pressing problem in relation to our underground water supply at present is the progressive contamination of the fresh water by an upward encroachment of salt water. Saline water occurs relatively near the surface of the fresh water along our coasts. Within the peninsula, the position of the highly mineralized water is varying, but usually quite deep. As the pressure head of the fresh water is reduced, the salt water moves upward by a definite ratio, the ratio depending upon the specific gravity of the saline and fresh water. In the examples cited by Ghyben and Herzberg, who first demonstrated this relation of fresh and salt water, for every foot of fresh water head that is lost there is an upward movement of saline water for approximately forty feet. At the same time there is necessarily a certain amount of lateral contamination. Peculiar conditions existing within the Florida reservoir do somewhat modify the actual working of the Ghyben and Herzberg theory. The final results, however, are basically the same.

With wise use of our artesian water supply the problem of saline contamination would never have become urgent. The annual rainfall of Florida is sufficient to furnish an adequate underground water supply for every purpose. However, because of a lack of understanding of the principles involved in artesian hydrology, several areas have already been damaged by salt water contamination. Among such areas may be mentioned Seminole and Volusia counties, and a large part of south and southwest Florida, particularly Manatee, Sarasota, Charlotte and Lee counties. The cities of Tampa and

St. Petersburg experienced severe difficulties with their municipal supplies, and were forced to abandon their original sources because of salt water contamination. Many other localities on both coasts might also be cited. A point to be borne in mind is that once salt water enters a well, the damage is irreparable and the well must be abandoned.

The protective measures necessary to guard against salt water contamination are simple and positive. In an area where there is danger of encountering brackish water, the well should be kept as shallow as possible. At all times and in all places, wells should be spaced at sufficient distances apart to insure against severe coning of the water table within a limited area. The casing should be of the best quality, and should be firmly seated in the rock and in large wells cemented in the rock. Last but not least, only that volume of water necessary should be used. We would not think of wasting oil, gas, or any other natural resource; why do we waste water, which is ultimately just as valuable? A wild flowing well is a menace to our artesian water supply, and an extravagance of the owner.

Drainage wells constitute another problem relating to the artesian water supply. The increasing use of these wells for the disposal of storm waters, liquid sewage, and industrial wastes is fast becoming a menace to the purity of the waters in certain localities. The extremely pervious nature of our limestones allows the free passage of these waste products through the rock. An instance has been noted where a section of an old inner tube was bailed from a new well being drilled at a considerable distance from a drainage well. Without a doubt, this inner tube entered the rock by way of the drainage well. If a large object was carried such a distance, unpurified water must be carried a much, much greater distance. This question deserves extensive study before definite conclusions can be drawn. It is, however, very evident that these drainage wells can very soon become a menace to both municipal and adjacent rural domestic supplies.

Since the inception of the Florida Geological Survey in 1907, that department has been active in a study of Florida's water supply. The work has been done both independently and in cooperation with the United States Geological Survey. All the data collected lead to but one conclusion: artesian water conservation in this state is imperative.

Legislation has been enacted aiming at artesian water conservation in several counties of the state. These laws are, however, entirely inadequate because the artesian water supply of any one county

is intimately connected with that of the adjacent counties. Seminole County, as an example, now has a law regulating the use and development of artesian waters. Volusia County bordering Seminole County on the north has a large number of flowing wells. This flowing-well zone in Volusia County is already highly saline, and as the pressure head is reduced in that area, the wells will become more saline. This increased salinity accompanying the loss of head will be transmitted laterally, and no matter how stringent the control measures may be in Seminole County, that county will be adversely affected by a lack of control in Volusia County.

It is clear that state-wide regulation of artesian water supply will eventually become a necessity. The sooner this is done, the fewer will be the acute water-supply problems to be solved and the smaller will be the degree to which the damage already done is irreparable.

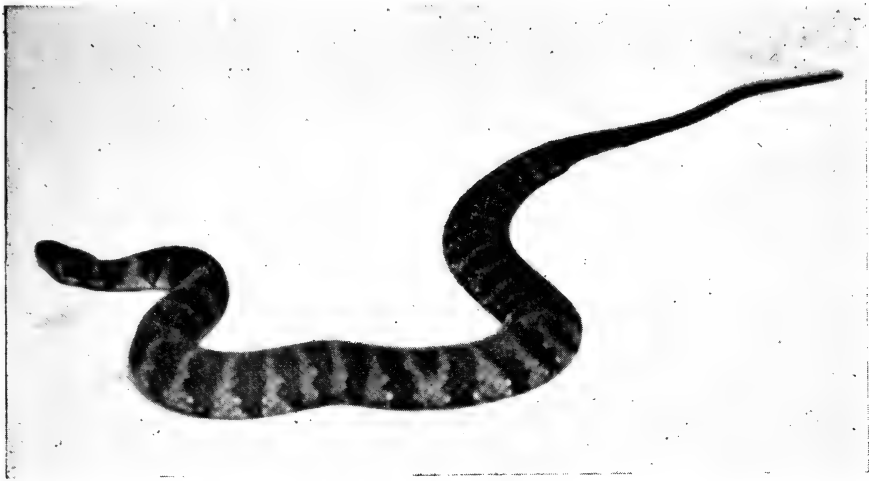

Fig. 1.—*Natrix sipedon pictiventris* (Cope).



FIG. 2.—*Natrix erythrogaster erythrogaster* Forster.



FIG. 3.—*Natrix cyclopion floridana* Goff, from Everglades.

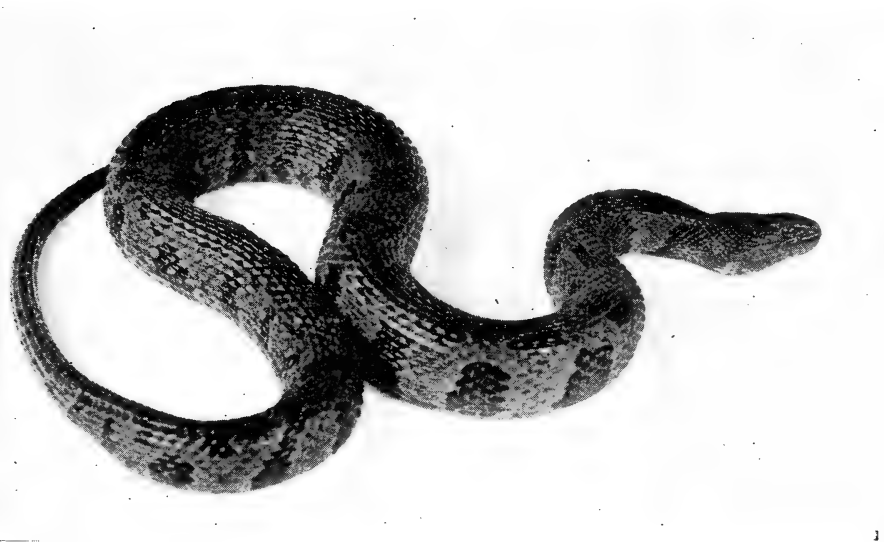

FIG. 4.—*Natrix taxispilota* (Holbrook), Oklawaha River, Marion County.

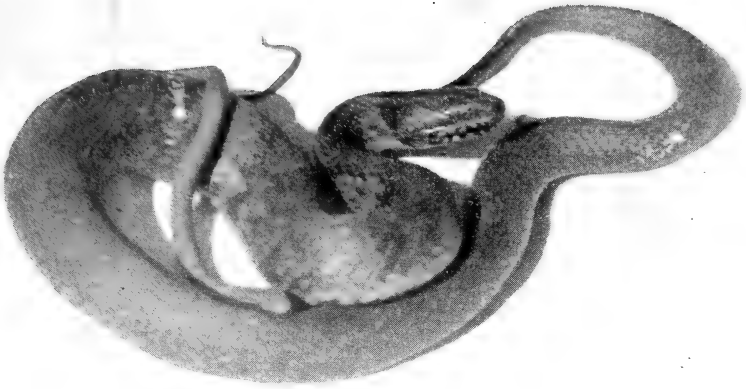

FIG. 5.—*Natrix compressicauda* (Kennicott).
From Key West



FIG. 6.—*Natrix clarkii* (Baird & Girard).
From Cedar Keys



FIG. 7.—*Natrix rigida* (Say), Marion County.

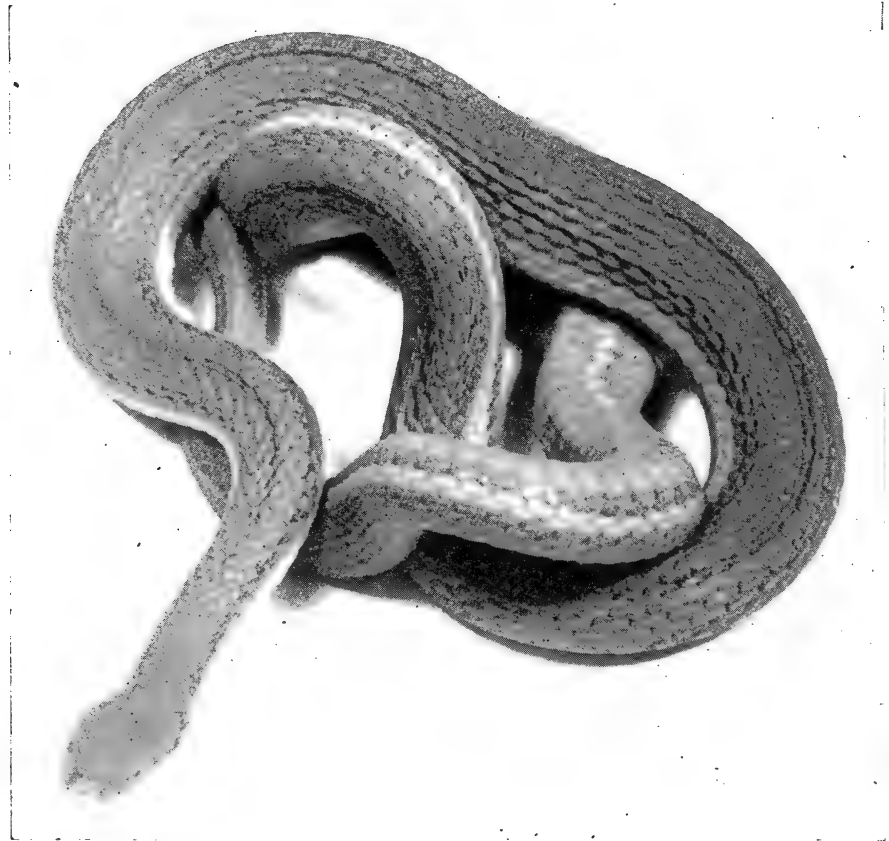

FIG. 8.—*Natrix septemcittata* (Say)

NOTES ON FLORIDA WATER SNAKES

E. ROSS ALLEN

Florida Reptile Institute, Silver Springs

Original data given here are based on collections made from 1933 to and including 1936. Under each species notes are presented on Florida range, habitat, number collected, abundance, habits (where known to author), and our record size. A few characters for the identification of each form are included. All the species discussed are non-poisonous, and all bear living young.

1. *Natrix sipedon pictiventris* (Cope)—Ponds, lakes, streams, marsh-lands; peninsular Florida, south to keys. Very common; collected 846 specimens. Black, brown, gray or red; about thirty transverse bands; ventrals partially or wholly edged with black, brown, red and gray, so as to enclose, wholly or partially, yellow or white areas. Feed on frogs, toads, fish, tadpoles. Broods number from 12 to 40. Principally nocturnal. Record length, 44 inches. (Fig. 1)

2. *Natrix sipedon fasciata* (Linne)—Ponds, lakes, streams, swamps; North Florida and Northwest. Fairly common; collected 32 specimens. Grayish brown with about thirty reddish brown transverse bands; ventrals red and yellow. Feed on frogs and fish. Broods number from 10 to 30. Principally nocturnal. Record length, 27 3-8 inches.

3. *Natrix erythrogaster erythrogaster* (Forster)—Swamps and ponds, North and Northwest Florida, as far south as Gilchrist County. Not common in Florida; collected 5 specimens. Uniform tannish-brown on back; ventral surface immaculate orange-red. Feed on fish and frogs. Broods number from 8 to 20. Record length, 39 inches. (Fig. 2)

4. *Natrix cyclopion floridana* (Goff)—Marshlands, lakes; North Central Florida and south. Very common; collected 126 specimens. Dark green, olive brown, or reddish brown, with numerous narrow black bands on sides and back; ventrals white or yellow; characterized by ring of small scales around the eye, separating the eye from the upper labials. Feed on fish and frogs. Broods number from 20 to 75. Active both by night and by day. Record length, 4 feet 10 inches. (Fig. 3)

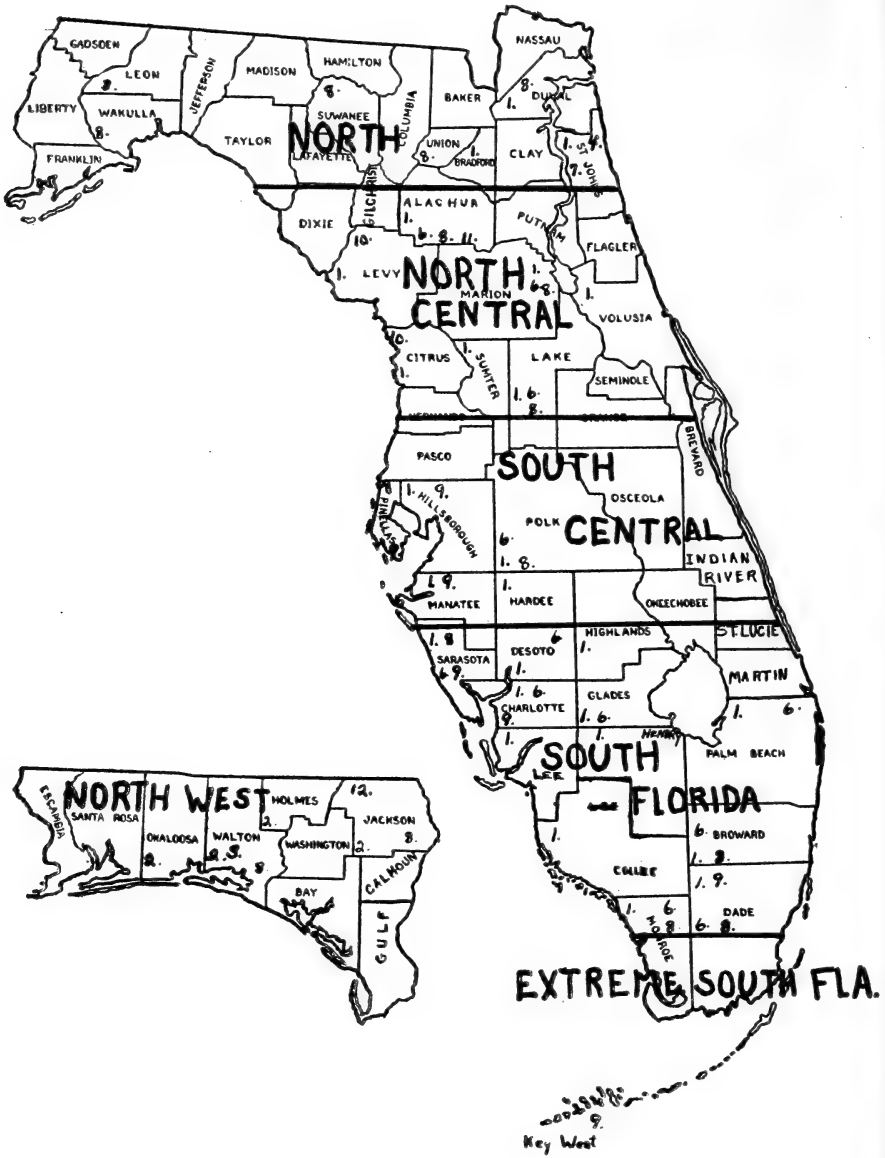

5. *Natrix taxispilota* (Holbrook)—Streams, rivers and lakes; state-wide. Common; collected 408 specimens. Light brown with dark brown alternating blotches; ventrals blotched with brown. Feed on fish, small snakes, lizards and frogs. Broods number from 15 to 40. Diurnal. Record length, 46½ inches. (Fig. 4)

6. *Natrix compressicauda* (Kennicott)—Shallow salt-water; south of Hernando County, West Coast around the Coast to West Palm Beach, all Keys down to and including Key West. Common; collected 27 specimens. Dark brown, light brown, gray, orange or orange-red; ventrals same color, with median row (sometimes two median rows) of light spots. Feed on fish, frogs; very adept at catching fish in shallow water, seizing them as they swim against their curved bodies. Broods number from 8 to 16. Principally nocturnal. Record length, 35 inches. (Fig. 5)

7. *Natrix clarkii* (Baird & Girard)—Shallow salt-water; Gulf of Mexico, Hernando County and northward. Very common at Cedar Keys; collected 22 specimens. Brown with three light stripes; ventrals brown with median row of light spots. Feed on fish and frogs. Broods number from 8 to 15. Principally nocturnal. Record length, 34 inches. (Fig. 6)

8. *Natrix rigida* (Say)—Streams, lakes; North Central Florida from Marion County northward. Rare; collected 5 specimens. Dark brown, with two darker dorsal stripes; ventrals yellow with two rows of brown dots. Record length, 22¾ inches. (Fig. 7)

9. *Natrix septemvittata* (Say)—Swift running streams; North-west Florida; Cope records it from Palatka, Putnam County, Florida; I have not collected any specimens in Florida, but one was authentically reported to have been found in Northwest Florida, Jackson County. Chocolate brown, with green lateral stripes; three indistinct black stripes between lateral stripes; ventrals yellowish, with two brown stripes, sometimes broken or blurred. Feed on fish and frogs. Record length, 22 inches. (Fig. 8)

ACKNOWLEDGMENTS

I acknowledge with thanks the help of the following: Dr. Leonhard Stejneger, U. S. National Museum; Dr. Thomas Barbour, Museum of Comparative Zoology, Harvard University; Dr. A. F.

Carr, Jr., University of Florida; Messrs. Stewart Springer, Zoological Research Supply, Englewood, Florida; L. F. Turner, DeFuniak Springs, Florida; Roy Montgomery, Miami, Florida; Craig Phillips, St. Petersburg, Florida; Harold Williams, Key West, Florida; George Van Hyning, Moore Haven, Florida; T. N. Van Hyning, Gainesville, Florida; Kenneth Freeman, Arcadia, Florida; and C. C. Goff, Leesburg, Florida; and my sister, Mrs. Eleanor Allen Coley, Batavia, New York.

NOTES ON THE FEEDING AND EGG-LAYING HABITS OF THE PSEUDEMYIS

E. ROSS ALLEN
Florida Reptile Institute

FEEDING HABITS

I have observed, through the glass bottom boats at Silver Springs, Florida, turtles feeding on water plants, and in certain places there were always more turtles feeding than in other places, apparently because of a certain variety of vegetation.

The commonly called hard-shelled cooter is continually being shot by fishermen because they believe that they eat fish and fish eggs. I have known for some time that they are vegetarians, but did not have sufficient proof and data to know whether they were carnivorous or not in their natural environment. Therefore, on November 15, 1937 I started to observe closely and gather data on a number of pseudemys under ideal conditions. I kept the turtles under observation until August 19, 1938. The pen, 6x20 feet, was built in the Springs where the warm water could run through and where plenty of water plants were available for feeding. The depth of the water was from four feet to shallow with beach of sand. The water temperature is constant the year round at 72°. The wire mesh was large and allowed fish to come and go freely in the pen. I threw in bread crumbs to attract the fish and the fish came and went continually, and at all times there were schools of minnows in the pen and never once during the nine months did I see the turtles attempt to bother any of the fish. The schools of fish showed no fear of any of the turtles in the pen. Then from time to time I proceeded to feed the turtles a great variety of plants and to notice results. The turtles under observation were adult Florida Terrapin (*Pseudemys floridana peninsularis*), Mobile Terrapin (*Pseudemys floridana mobilensis*), Red-bellied Terrapin (*Pseudemys nelsoni*) and the Suwannee Terrapin (*Pseudemys floridana suwanniensis*).

As the turtles ate some of the things more readily than others, I have the food divided up into three divisions, as follows:

ATE READILY	ATE SPARINGLY	REFUSED TO EAT
Saggittaria Sinensis	Watercress ¹	Live fish
Saggittaria Grandi	Japanese lily pad	Live minnows
Fox tail	Japanese plum tree leaves	Pansies
Myriophyllum	Palmetto tree leaves	Pine needles
Coral ludwigia	Johnson grass	
Needleleaf ludwigia	Thistle	
Money wort	Peanut plants	
Water moss	Touch-me-not	
Water lettuce	Spider dock	
Water hyacinth ²	Duckweed	
Poison ivy	Arrowleaf	
Elderberry leaves	Tiger lily	
Ripe elderberries	Bread	
Lily pads	Meat	
	Dead fish	
	Dead minnows	
	Canned dog-food	

During the nine months I noticed that these turtles had tremendous appetites. Therefore, my curiosity was prompted to find out how much they could consume. I, accordingly, let them go without food for two days and then on August 18, 1938 we took inventory. The list follows: one, Mobile Terrapin (*Pseudemys floridana mobilensis*); forty, Florida Terrapin (*Pseudemys floridana penun-sularis*); twenty-eight, Red-bellied Terrapin (*Pseudemys nelsoni*); twenty-four Suwannee Terrapin (*Pseudemys floridana suwan-niensis*), and eleven *Pseudemys Rugosa*³ from Cuba; a total of one hundred and four turtles. Then at ten A. M. August 18th we collected and measured five bushels of Saggittaria Sinensis and fed it to the hungry turtles. Exactly twenty-four hours later, ten A. M. August 19th, we measured the Saggittaria Sinensis that was left, which amounted to 1¼ bushels. In that short period of time they had consumed 3¾ bushels of Saggittaria Sinensis, an amazing amount of food for those turtles.

¹ Baby turtles ate this readily.

² Could not eat easily unless the water hyacinth was upset in the water.

³ We found that *Pseudemys Rugosa* ate meat just as readily as vegetation; otherwise, its feeding habits were the same as those of Florida Terrapins.

EGG LAYING HABITS

Our large Florida Terrapins seemingly have only a few natural enemies, and yet, with their prolific breeding habits, comparatively few reach maturity. Large alligators eat only a few at certain times of the year. Herons, black bass, carnivorous turtles eat about 60% of the newly hatched turtles. I found, to my surprise, that 95% of the eggs laid were destroyed by skunks, raccoons, opossums, king snakes and hogs.

On January 5, 1938, full moon, the favorite time for pseudemys to lay eggs, two assistants and I proceeded to examine the banks of the Ocklawaha River for turtle nests from Moss Bluff upstream for a distance of about five miles. During the day we found 287 freshly made nests of which number 282 had already been eaten by animals. Of the five good nests, we found two just as the turtles were laying the eggs, of which I made pictures. It seemed just good fortune that the skunks had not found the other three nests. In estimating the percentage of nests destroyed, I took into consideration the fact that turtle nests are very hard to find and we possibly missed some. A turtle so skillfully hides the nests that it takes an experienced eye to notice certain characteristics that give it away. It was very easy to find the nests that were destroyed because the white shells were scattered about. In the nests which we found, the numbers of eggs were: two nests, 19; two nests, 20; one nest, 15. The majority of nests had the batch of eggs in the center and one egg on each side.

At another time I watched a Florida terrapin carefully dig her nest and lay eggs and I made several pictures while the operation was going on. She had just crawled out on the bank about twenty feet from the water. Then she started scratching the dirt with her hind feet, first with one foot and then the other, and kept alternating as the work progressed. She would dig her claws in and then grasp a clawful of sand, lift it out and throw it to the rear. Occasionally she would stop her digging and scratch in the dirt beside her nest, first with one foot then the other, causing two shallow holes on either side of the deep hole. The holes on either side were broad while the deep hole had a small entrance but she had hollowed it out at the bottom, making it much larger at the bottom than at the top. After thirty-two minutes of continuous work, repeating the same motion many times, and when the depth of the center hole was the

length of her hind leg, she immediately started to lay eggs. She laid eggs at twenty to twenty-nine second intervals. Eggs were slightly soft when laid and they hardened very fast. She paid little or no attention to my investigations and taking pictures. Some of the eggs rolled into the side holes. She laid a total of twenty-three eggs, arranged them to suit her with her hind feet, then proceeded to cover them up by scratching the sand in and pushing it down, then smoothing over with her plastron. At the end of eight minutes she had it covered up to satisfy her and walked away, never once having looked at her eggs or work. These same eggs hatched eighty days later.



FIG. 1.—Five bushels of eel grass (*Sagittaria sinensis*).



FIG. 2.—Feeding the tame hungry turtles part of the 5 bushels of eel grass.



FIG. 3.—The five bushels of eel grass fairly covered the pen with a thick mat. The hungry turtles eagerly start to feed. (10:10 A. M., Aug. 18, 1938)



FIG. 4.—Exactly 24 hours after food was put in pen $3\frac{3}{4}$ bushels had been eaten, leaving only $1\frac{1}{4}$ bushels (10:00 A. M., Aug. 19, 1938)



FIG. 5.—After the turtles' appetites have been appeased, they crawl out on the bank to rest and sun-bathe. (10:15 A. M., Aug. 1938)



FIG. 6.—Florida terrapin (*Pseudemys floridana peninsularis*) digging nest. The neighbor is a casual onlooker. (April 8, 1938, in captivity.)



FIG. 7.—Florida terrapin in act of laying first egg. (April 8, 1938, in captivity.)



FIG. 8—Florida terrapin in act of laying 14th egg. This egg is about to drop into center hole. Three eggs have accidentally rolled into side hole. (April 8, 1938, in captivity.)



FIG. 9.—Florida terrapin, after having covered up nest neatly by smoothing over with plastron, leaves the nest. Notice that the turtle has drawn up legs because of intrusion of photographer. (Jan. 5, 1938, on Oklawaha River bank, near Moss Bluff.)

A PRELIMINARY REPORT ON STUDIES OF MOSS HABITATS AND DISTRIBUTION IN NORTH CENTRAL FLORIDA

RUTH SCHORNHERST

Florida State College for Women

Mosses, although small plants as individuals, are really a very conspicuous part of the vegetation of the earth. One has only to see the total lack of them in woods that have been burned to appreciate this fact. They appear in almost every habitat: along stream banks, in swamps, in water, along roadside ditches, on trees and rocks, in fields.

One of the first questions almost invariably asked of a person studying mosses is "*Are mosses of any use?*" Their value and uses are so diversified that a book could be written on the subject. Moss banks in the woods serve as excellent germinating beds for seeds of forest trees since they tend to provide the proper degree of moisture and protection. Nurserymen frequently make a mixture of dried moss and soil for seed beds.

Leaves of mosses are arranged like the shingles on a roof. The rhizoids which attach them to the soil act as soil binders for the surface layers. Thus mosses are efficient in conserving moisture, and prevent both flood and drought. Their value in preventing erosion may be noticed along ditches: the bare places soon show miniature gulleys, while the moss-covered banks remain intact. One gram of dry moss absorbs twice its own weight in water in one minute, and three or four times its weight in ten minutes. This rapid absorption prevents run-off after rains. Since mosses tend to hold water tenaciously the soil beneath likewise remains moist. Thus mosses around the bases of trees in forests are partly responsible for the effects of forests on flood control.¹ It has been suggested that mosses be planted in connection with reforestation.

Mosses are rather sensitive to acidity and alkalinity, and may thus serve as criteria of the condition of the substratum. They are likewise an indicator of the amount of soil moisture. Harper states² that "Native vegetation is probably the most sensitive indicator of geographical conditions that can be found; for every variation in

¹ Grout, A. J., "Mosses," *Sci. Mo.*, Vol. 38, pp. 270-274.

² Harper, R. M., *Geography and Vegetation of Northern Florida*, Fla. Geological Survey, 6th Ann. Report (1914), pp. 163-437.

soil or climate is reflected in some way in the vegetation." This statement seems to be true for mosses as well as for higher plants, of which he was speaking.

Sphagnum or peat moss is perhaps the most important moss in the conservation of moisture.¹ The cells are hollow and equipped with small pores, and the plants will absorb as much as ten to fifteen times their weight in liquid. During the World War Sphagnum was used effectively in surgical dressings because of this high absorptive power. It is also used in packing nursery stock for transportation, for stable bedding, and as mulch around plants. Live fish may be carried long distances packed in moss.

In gardening mosses are frequently used as substitute for grass where shade is too deep for the grass to grow, and paths and walks carpeted with mosses are most attractive. Dried Polytrichum moss is sometimes used for coarse brushes. Mattresses and pillows are stuffed with moss—not Florida or Spanish Moss, for that is no moss at all, but a flowering plant. Not so many years ago mosses were woven into braid and used for hat trimming.

Any discussion of the value of mosses would be incomplete if it did not suggest their aesthetic value. For sheer beauty and delicacy of form there are no plants which can surpass them.

The second question asked is, "*What is a moss?*" Mosses are rather simple plants having stems and leaves but no roots, and capable of living independently. They are held in place by very fine filamentous structures known as rhizoids. Their leaves are not much like those of higher plants, for they are only one or two cells thick and show little specialization of tissue. The stems are very simply organized.

Mosses reproduce asexually by spores—small one-celled bodies produced within capsules. These capsules are so variable in structure that they are frequently used in identification of species. They open by a tiny lid, under which is usually a fringe of teeth which aid in spore dissemination. In wet weather the teeth close over the spores and protect them, but in dry weather they curl back and allow the spores to escape. Spores, like the pollen of higher plants, may be carried by animals, wind or water. Under favorable conditions they sprout and develop new moss plants.

Mosses also reproduce sexually. The plants may be bisexual like a rose or sweet pea, or they may be unisexual like willows or papayas. After fertilization new spore capsules appear. Thus it is seen that mosses reproduce alternately by sexual and asexual means.

Mosses are an ideal group of plants as far as the worker is concerned. They may be gathered in the field, packeted and labeled, and set aside indefinitely for examination at leisure. They are remarkably free from animal molestation. Although the plants look most unpromising after being dried for several weeks, months or even years, they look as good as new upon soaking for a few minutes in hot water. The study and pursuit of mosses, like the study of birds or trees, soon becomes an all-consuming interest and provides healthful out-of-door recreation at all times of the year, for mosses may be collected the year round.

For some reason the mosses of north Florida—and for the entire state in general—have not been studied as carefully as the flowering plants or ferns. This may be accounted for, in part at least, by the lack of available literature and descriptive material for this region. Many of our mosses are different from northern ones, for which manuals have been available for many years. Fortunately this handicap is rapidly being overcome, for a new manual including Florida³ is in process of publication. Another reason for the lack of study is that many people suppose that the study of mosses requires some special training or ability. Dr. A. J. Grout says that anyone with a little perseverance can learn to identify at least 75 in the field with only a hand lens.

There are only three published lists of mosses of the state^{4 5 6} except for scattered reports for one or two genera or species. These furnish the only records except those appearing in Grout's new manual.³ The former lists cover very restricted areas. There are no lists for northern Florida. The writer has had access to unpublished lists of collections made by Dr. Herman Kurz and Miss Olivia Embrey.

The area which this report covers is, roughly speaking, the region between the Aucilla and Apalachicola Rivers and the Georgia-Florida state line to the Gulf of Mexico. The section is divided

³ Grout, A. J., *Moss Flora of North America*. Vol. 1, Parts 1-3; Vol. 2, Parts 1-3; Vol. 3, Parts 1-4 (1928-1938). Published by Author. Newfane, Vt.

⁴ McFarlin, J. B., "Mosses of Polk County, Florida," *Bryologist*, Vol. 40 (1937), pp. 49-57.

⁵ Murrill, W. A., *Bryophytes of Alachua County*, (Gainesville, Fla., 1938), pp. 1-9.

⁶ Rapp, Severin, "A list of Mosses from Sanford, Florida," *Bryologist*, Vol. 22 (1919), pp. 50-54.

into two rather pronounced divisions.⁷ The northern consists of a belt of sandy red clay hills with numerous lakes and ponds. The southern division is more uniform. Here the soil is largely sandy and porous, and rises gradually from the coast. There are several islands of rich soil, one along the Wakulla River, another along the St. Marks River, which have yielded different mosses than those of the sandy coastal plains soils, but the parts grown up to scrub oaks produce scanty collecting grounds for mosses both as to quantity and variety. In the northern section the soil is generally richer and there are numerous lakes, streams and swamps. It is not surprising, therefore, to find a wide variety of mosses. In general, where there is a varied flora of higher plants there is also a wide variety of mosses. For instance, from only three scattered collections along the Apalachicola River Bluffs the yield was 39 species, and in two small swamps near Tallahassee the totals were 31 and 32 respectively. The nearer the coast the fewer kinds of mosses found, except in the swamps. More work needs to be done here before any conclusions can be reached.

The mean annual rainfall in Tallahassee is 56 inches, with more rain in the warm months of the year. The climate is characterized by mild dry winters and wet summers. This, associated with the fact that within the region are many lakes and swamps, means that Bryophytes are produced abundantly. There is not sufficient variation in elevation to produce noticeable effect on distribution, elevations ranging from about sea level to 300 feet near Gretna. Differences in soils seem to produce more appreciable effects.

As a whole there is little surface outcropping of rock; therefore the forms commonly found on rocks are almost lacking from the author's lists. Occasionally mosses are found on bricks, but these are typical soil forms which seem merely to have taken advantage of the moist surface offered. To date only eleven species have been found growing on rocks.

In the rich swamps the ground is almost solidly carpeted with luxuriant growth of mosses, and the tree trunks to a height of 8—12 feet, sometimes higher, are often well covered. In all, 43 species have been collected from standing or fallen trees. As to be expected, the largest number is to be found on soil, for 92 species have been collected in deep woods, along roadsides, in ditches, in swamps and in old cultivated fields. Several species of *Sphagna* have been

⁷ Sellards, E. H., "Geology between the Ochlockneee and Aucilla Rivers in Florida," *Fla. Geol. Survey, 9th Ann. Report* (1917), pp. 85-139.

collected but have not as yet been identified, and five species of mosses growing submerged in water are included.

Since this problem is in reality only well under way, having been in progress slightly over a year, the author was curious to compare figures with some rather complete collection in this section of the country. Mohr⁸ gives the figures which, in the following table, are compared with those of the present writer:

	MOHR	SCHORNHERST
Families	20	23
Genera	64	61
Species	154	115
Varieties	16	8

It is always of interest in a taxonomical problem to see how many new reports for distribution for a region may be found. To date this list contains eleven species with no published record for Florida as far as the author has been able to determine. Of these, four have been collected by Dr. Kurz or Miss Embrey. Several mosses previously reported only from south Florida⁹ have appeared in the collections, extending their range northward considerably.

Steere,¹⁰ working on the mosses of the Keweenaw Peninsula, Michigan, states that "There is remarkable parallelism of Bryophyte distribution to that of vascular plants It can be predicted with confidence, on the basis of studies and maps already made that many of the Bryophytes will be found to fall into phytogeographic groups with as much precision as do the flowering plants, and furthermore, into the very same groups." Since the vegetation of north Florida falls into so many groups,² it will be interesting to study the distribution of mosses from this angle. No studies have been made of moss associations or of the relation of mosses to other plants.

Grout,¹¹ working mostly in peninsular Florida, states that while the southern moss flora is rich in quantity, the number of species is fewer than that found in the north. It will be interesting to see if

⁸ Mohr, Charles, "Plant Life of Alabama," *Geological Survey of Alabama* (1901), pp. 289-309.

⁹ Britton, E. G., "West Indian Mosses in Florida," *Bryologist*, Vol. 22 (1919), p. 2.

¹⁰ Steere, W. C., "Critical Bryophytes from the Keweenaw Peninsula, Rhodora," Vol. 39 (1935), pp. 1-14.

¹¹ Grout, A. J., "Collecting Mosses along the Florida West Coast," *Bryologist*, Vol. 30 (1927), pp. 29-30.

this proves to be the case in the northern part of the state. Since the author is still finding new mosses on every collecting trip, the list for the region is decidedly incomplete. This area has been virtually unexplored as far as the mosses are concerned, so the study is continually turning up interesting forms and new ideas challenging investigation. The author hopes that this paper may have stimulated someone to tackle the mosses of his or her section of the state and thus add to our knowledge and to his or her own pleasure.

ARE WOMEN CLAIRVOYANT?

JULIA H. HEINLEIN AND CHRISTIAN PAUL HEINLEIN

Florida State College for Women

The primary purpose of the investigation which is described in this paper is to ascertain the extent to which college women are clairvoyant to certain situations under laboratory control. Throughout this paper, the word clairvoyance is understood as the personal capacity to know the nature of objects or things at some position in space and time without the known objects or things being mediated through any of the currently known sense organs. This extra-sensory capacity of clairvoyance is sometimes called intuition by the layman. According to a popular tradition of long standing, women are supposed to possess in large measure this self-revealing type of knowledge.

In practically all of the previous investigations of clairvoyance, the subjects to be tested were priorly informed about the specific material which they were expected to perceive. For example, in the parapsychological investigations at Duke University in which ESP cards were utilized, the subjects were informed before experimentation began that a given deck of cards consisted of five patterns quintuplicated. The nature and the forms of the patterns to be perceived were also priorly demonstrated to each subject that was tested. In a recently published article¹ the present authors have pointed out why neither the data nor the interpretations advanced by the Duke parapsychologists and their co-workers are acceptable to the scientific psychologist.

It is herein maintained that any technique which provides a subject with cues or previous knowledge of the specific patterns and distribution of extra-sensory material used can *never* serve as a *crucial test* of clairvoyance. To be clairvoyant, a subject should be able to describe the structure of another person's thinking process without reference to any cues or suggestions which that person might voluntarily or involuntarily supply. To perceive an object or a thing clairvoyantly, a subject should be able to describe the form of the object or indicate in some communicable way the properties of the thing in question without having to be told beforehand the actual

¹Heinlein, J. H., and Heinlein, C. P., "Critique of the Premises and Statistical Methodology of Parapsychology," *The Journal of Psychology*, Vol. 5 (1938), pp. 135-148.

form of the object or the observable properties of the thing which he is expected to select at a random position in some spatial series through an act of sheer guessing.

In order to plan a crucial test in which the specific stimulus patterns consist of *elements* already a part of the daily adaptive behavior of each subject, the authors turned to language for their material.

A preliminary free-association-word task was assigned to the members of a class of 32 students for the purpose of ascertaining individual preference, if any, for syllabic type. The task with which each of these students was confronted consisted in the writing of a list of 25 words through the function of free association. The simple instruction given each student was as follows: "Write as rapidly as possible a list of 25 words of your own free choice."

In classifying the 800 words according to syllabic type, approximately 24% were monosyllabic, 38% dissyllabic, 29% trisyllabic, with the remaining 9% representing higher syllabic forms. Further examination of these data revealed the fact that some students have an individual preference for monosyllables, other students for dissyllables and a few for trisyllables and higher polysyllabic types. Since the sample of data obtained from such a small group did not warrant any generalizations concerning the most probable tendency within a larger and more representative group to prefer one syllabic type over another, the authors finally decided on the arbitrary method of selecting 25 words for each of five syllabic forms, thoroughly shuffling these by a special technique, and extracting without knowledge of word or form a total of 25 words for use as extra-sensory material.

With this arbitrary method of selection in mind, one-hundred and twenty-five words as potential stimulus patterns were selected from the 1938 edition of Funk and Wagnals College Standard Dictionary. Five lists of words representing five syllabic types were selected, each list consisting of 25 words arranged in alphabetic order. Three words beginning with the letter X, one word beginning with the letter Y, and one word beginning with the letter Z were not represented in the five lists.

Words were selected which do not occur frequently in the daily conversation of college students, yet which, the authors believed, were part of the vocabulary of every college student. The point of view was adopted that each college student was familiar with every word selected at one or more of the following levels of response: the subject, if presented with any one of the words, would be able (1) to spell the word; (2) to write the word; (3) to pronounce the

word; (4) to recognize the word as having (a) seen, (b) heard, (c) spoken, or (d) written it on some previous occasion; (5) to use the word meaningfully in a sentence; (6) to define the meaning or operations of the word; and (7) to offer synonyms or antonyms of the word. It was held that levels (1) and (2) were primary and sufficient to warrant correct clairvoyant perception if such perception existed at all. The complete lists of words representing the five syllabic types are given below:

I. (One syllable words): Asp; Brad; Cud; Dock; Elf; Flume; GhouL; Heath; Ilk; Joist; Knob; Lark; Moat; Nape; Oats; Phlox; Quirk; Ramp; Slade; Tusk; Urn; Valve; Wrench; Yule; Zeal.

II. (Two syllable words): Annals; Blazon; Claver; Dormer; Excerpt; Fillip; Gopher; Hotchpotch; Ibis; Joggie; Kickshaw; Lacrosse; Mandrill; Nomad; Ochre; Plastid; Quinsy; Respite; Spangle; Tunic; Unction; Vermuth; Windlass; Yeoman; Zithern.

III. (Three syllable words): Anthracite; Balustrade; Caterwaul; Dilletante; Equipage; Fiasco; Gyroscope; Hippodrome; Incursion; Juniper; Knavery; Lumbago; Matadore; Neophyte; Oligarch; Peristyle; Quiddity; Roundelay; Scallowag; Turpitude; Undertone; Vesicle; Waterspout; YellowthroaT; Xenia.

IV. (Four syllable words): Appurtenance; Biostatics; Contumely; Dessication; Epistrophe; Fecundity; Granulation; Hegemony; Iconoclast; Judicature; Kaleidoscope; Lapidescence; Metallurgy; Necromancer; Osculation; Palliative; Querulousness; Relegation; Streptococcus; Tiddledewink; Ultramarine; Valediction; Whortelberry; Xylographer; Yterbium.

V. (Five syllable words): Agglutination; Brachycephaly; Circumlocution; Dissimilitude; Exacerbation; Fortuitousness; Geniculation; Hypothecary; Ingratiation; Juxtaposition; Kinematograph; Laryngology; Myocarditis; Negotiator; Obituary; Perspicuity; Quadrinomial; Reciprocity; Saturnalia; Telencephalon; University; Vicariousness; Whimsicality; Xenophobia; Zymogenesis.

Each of the 125 words was capitalized in heavy pica print on a rectangular slip of 24 lb. wt. bond paper measuring 1½x6 centimeters. Each slip of paper was inserted into a specially prepared flat capsule of opaque bristol board measuring 2x8 centimeters. Each capsule thus containing a single word was sealed with Scotch tape, the latter seal serving also to identify the word in upright, face position. The printed words were sealed in order of syllabic type.

The five syllabic types were separated into five piles of capsules, each pile containing 25 capsules of a given syllabic type. The twenty-five sealed capsules containing monosyllables were then deposited in an aluminum pot with hinged lid, and shaken vigorously a total of fifty times. This thorough mixing of the capsules constituted the word—shuffle. The father of the junior author who was unacquainted with the purpose of the shuffle was blindfolded and asked to select at random 5 sealed capsules from the pot which contained the lot of 25 monosyllables. After this was accomplished, the process of shuffling and blind selection was applied to the remaining four piles of capsules representing the other four syllabic types and continued until five capsules had been blindly selected from each pile. The composite pile of 25 randomly selected capsules, made up of five capsules for each syllabic type, was then shuffled 50 times. Each capsule of this thoroughly shuffled composite pile was next selected at random until every capsule had been removed from the pot.

These final 25 sealed capsules, in the order of their random selection, were then fitted into a templet and doubly fastened in place by rubber cement and Scotch tape. The templet in this instance consisted of a sheet of paper, $8\frac{1}{2}'' \times 14''$, on which were drafted two columns separated by one-half inch. Each column was divided into 12 spaces, each separate space measuring $15/16'' \times 3\frac{1}{4}''$. A single space, making up the twenty-fifth, was centered to rest on top of the two columns of 24 spaces. A single word capsule, with face outward identifiable by the position of the seal, was fastened to and congruously framed by each space. The completed templet with attached capsules was fastened by glue to a piece of heavy cardboard as back of a picture frame. A mimeographed duplicate of the templet was cemented to a second piece of heavy cardboard to correspond in position with that of the original templet. The mimeographed form, face outward, was inserted in a glass-enclosed picture-frame. On top of this form backed by heavy cardboard was placed the templet with attached word capsules. Thus the capsuled templet was firmly held in position between two pieces of heavy cardboard and arranged in such a way that each space of the invisible templet was made to coincide with each corresponding space of the visible duplicated blank. The cardboard back was nailed to the frame and sealed to the rim of the frame by Scotch tape.

With the verbal contents of this frame unknown to any person and serving as the stimuli for clairvoyant perception, each member of a group of 300 women was asked to serve as subject for a task

in which the following instructions were given. These instructions define for the reader the purpose of the task.

The capacity to perceive correctly various arrangements of visual objects without the aid of the human eye is known as "clairvoyance" or "intuition." You may secure some understanding of your intuitive capacity to know things hidden from view by wholeheartedly cooperating as subject in a test situation which has been especially planned to reveal clairvoyance. In order to provide the best index of your powers, you must make every effort to adopt the proper experimental attitudes before the test begins and to maintain these same attitudes throughout the test period. Subjects who have an active interest in the task, who are able to give a high degree of concentration to the task as presented, who are able to avoid and to disregard the momentary appearance of any distracting thoughts or feelings, who wholeheartedly believe in their ability to succeed, who adopt before the task begins and throughout the task an openminded, experimental attitude, are the subjects who achieve the best results.

In this sealed picture frame enclosed by a glass-plate appears a mimeographed test-form exactly like the one which you have received. Behind the visible form in the frame is a duplicate form invisible to the human eye. The outline of the invisible form coincides with the visible form which you see in the frame. In each of the sections of the invisible form there is printed in capital letters a word selected from a college standard dictionary. Twenty-five words are printed in the form not present to view, one word in each of the twenty-five sections.

Your task is to perceive clairvoyantly the correct words in their proper sections as they are concealed within the frame. As soon as you image a word as belonging to a certain section of the form concealed in the frame, write the word in the same section of your own test form. Continue this process for the remaining sections of the test. If a word image for a given space appears clear and certain, place a check mark in front of the word. If you are wholly in doubt about a given word which you have written, place a question mark in front of the word. If you are in doubt concerning the correct word for a given section, you may guess. However, whenever your response is a mere guess, be sure to enclose in a parenthesis the word which you have written. You must not write more than one word in each space. It is not necessary that your responses be in serial order; you may skip around if you so desire.

Please write each word plainly so that it can be read clearly by an examiner.

After the task had been completed by each of the 300 students and after all data had been collected, the stimulus frame was disassembled by the senior author in the presence of Miss Elizabeth A. Becknell, former graduate assistant at Florida State College for Women, and present member of the Florida Academy of Sciences.

The word capsules in the stimulus frame were opened and the words double checked and copied in the exact order in which they were concealed in the templet. The complete list of stimulus words progressing in order from the topmost space down through the left and right columns respectively were as follows:

Ibis; Palliative; Yellowthroat; Kaleidoscope; Hegemony; Reciprocity; Slade; Ghoul; Roundelay; Querulousness; Lacrosse; Oats; Fortuitousness; Turpitude; Joggle; Fiasco; Nomad; Elf; Ilk; Ultramarine; Brachycephaly; Caterwaul; Zithern; Exacerbation; Whimsicality.

While the results obtained from this test situation may be summarized very briefly, they are not without significance.

In an examination and analysis of the syllabic content of the total distribution of words, 26% were words of one syllable, 31% were words of two syllables, 23% were words of three syllables, 7% were words of four syllables, 4% were words of five syllables, and less than 1% were words of six and seven syllables. Approximately 8% of the spaces were left blank by the students. The above percentages are given within an error of less than 1%.

Of the total number of students, 7% indicated by check marks that every one of the words which they had written was clearly perceived in clairvoyant transmission. Sixty-eight per cent made no check marks on their sheets, indicating thereby that they received no clairvoyant impressions of the words which they wrote. Sixteen per cent judged themselves to have perceived one to five words clairvoyantly. The remaining students of the group, making up 9%, judged themselves to have perceived clairvoyantly words ranging in number from 6 to 23.

What a person thinks he has accomplished by an assumed or felt act of clairvoyance and what he has actually accomplished in the light of his assumption or feeling are two entirely different situations as borne out by the following most important discovery of this investigation. A triple checking of every student's responses reveals the following startling fact: namely, *not one student had written down as much as one single word of those words which were contained within the stimulus frame.* Not one single hit had been scored irrespective of what attitudes the subjects may have adopted. The parapsychologists who have endeavored to prove the existence of clairvoyance through the spurious techniques of statistical numerology may interpret the present finding as the result of clairvoyant inhibition induced by precognitive, negative telepathy. This

objection is automatically rendered ineffective and invalid by the method of control which the authors introduced, since no person knew beforehand just what words were contained within the stimulus frame.

In order to ascertain the extent to which college women are able to perceive clairvoyantly standardized levels of musical preference to a series of piano compositions conventionally reproduced on an electric phonograph, the authors presented under special conditions the Hevner-Landsbury Musical Discrimination Test to a third group of 146 students.

In the first of two different test situations, the Hevner-Landsbury printed test form together with the standard instructions were given to each student. Each student tested was asked to follow the printed set of instructions while they were read aloud by the experimenter. At the close of the instruction period, the experimenter added the following remarks: "After all, I shall not play these selections for you on the phonograph. Instead, I shall ask you to perceive clairvoyantly the right answers contained in the folder which the testers have published. The folder with the correct answers in it is located in my office. Now turn over your test sheet and cross out, in accordance with the instructions given, all those letters which correspond with the correct answers."

Each subject who had taken the test without music as a task in clairvoyant perception, was given the test in the standard manner with phonographic reproduction on the following week. The data obtained from each student responding to the two different types of test situations were projected against the norms prepared by Hevner and Landsbury. For the second type of test situation in which each student was presented with electric phonographic transcriptions of the standardized test recordings, the distribution of raw scores in terms of transmuted deciles for the 146 students tested is as follows:

Decile -----	1	2	3	4	5	6	7	8	9
Frequency -----	40	21	12	8	25	12	14	4	10

For the first type of test situation in which each student was required to perceive clairvoyantly the correct answers, the distribution of raw scores in terms of transmuted deciles for the same 146 students is as follows:

Decile -----	1	2	
Frequency -----	137	9	None beyond the second decile.

Of the nine students who reached the 2nd decile without musical stimulation, five students fell in the first decile, while the remaining four reached the third, fifth, seventh and eighth deciles respectively when musical stimulation was provided.

GENERAL CONCLUSION

From the nature of these results obtained, the authors fail to discover a single convincing trace of clairvoyance in the responses of any one student among the students who were tested. Throughout the entire investigation all sensory cues were completely eliminated and all data were triple checked by trained examiners. In the light of the techniques and controls adopted, the authors finally conclude that if clairvoyance exists at all, it did not reveal itself in this random cross-section of a college population.

The authors wish to thank the various faculty members at Florida State College for Women who contributed subjects for this study.

OVULATION TIME IN PRIMATES

JAMES H. ELDER

Yale Laboratories of Primate Biology, Orange Park

For several years there has been a lively controversy on the question of periodic fertility and sterility in primates. The fact that this problem was solved long ago for other mammals may be attributed to greater freedom for controlled observations. Because of certain conventional restrictions on the use of human subjects, much of our accurate knowledge of the problem has come from experimental work with monkeys and apes.

According to the periodic fertility hypothesis, as it applies to those primates exhibiting menstruation, ovulation occurs once during the cycle. Unless the male germ cells are present at this time, or within a few hours, there will be no fertilization. The hypothesis excludes the possibility of additional or so-called "spontaneous" ovulation at other times in the cycle. A large amount of clinical and experimental evidence gives much support to this hypothesis, and it is now fully accepted by many biologists.

It is not the purpose of this report to argue the case for periodic sterility from data which are already available. This was done most thoroughly by Hartman² in 1936. After reading his summary one is impressed by the lack of good experimental evidence and careful observation and recording. The present report deals with research of the type which Hartman himself has offered as necessary for a solution of the problem.

One of the primary aims in using apes and monkeys for research purposes is to obtain knowledge useful to man. Since I am about to describe results obtained with chimpanzees instead of women it will be necessary that we agree on a few fundamental points before we can accept the pertinence or validity of such evidence in its application to primates in general. It is not necessary that we assume ovulation in man and ape to be governed by identical processes—this is one of the points to be demonstrated—but it is necessary that we appreciate the similarity of physiological function in the primates.

¹ This report is based upon results of investigations supported by the Committee for Research in Problems of Sex, National Research Council, at the Yale Laboratories of Primate Biology.

² Hartman, C. G., *Time of Ovulation in Women* (Baltimore: The Williams & Wilkins Co., 1936).

The discovery, by the inquiring layman, that apes have regular menstrual cycles seldom fails to produce a deep impression. One who is reluctant to admit genetic relationships of man and other primates and attempts to rationalize other anthropomorphic characteristics of the ape is usually awed by the menstrual cycle.

It should be remembered that the phenomenon of menstruation appears only in some of the higher primates—old world monkeys, anthropoid apes, and man. The length of the menstrual cycle is the same in several species. Graphic representations of 1000 cycles in rhesus monkeys and women are indistinguishable, both showing medians and modes of 28 days. As far as we have been able to discover the activity of endocrine glands, and changes in the ovary, uterus, and vagina bear the same relationship to the cycle in the different species.

There are several characteristics of the chimpanzee which make it an ideal subject for sex research. Those which make it especially suitable for ovulation studies are a cycle length of 35 days—extending the possibility of comparisons with other primates—and the presence of external genital swelling corresponding to the period of follicular development.

Most of our knowledge of ovulation time in the chimpanzee has been obtained through the use of the controlled mating technique. The following brief description of this method, quoted from a published report³ on the sexual cycle of the chimpanzee, will facilitate interpretation of the illustrations:

This method consists simply of permitting a single, effective, sexual contact for a limited period of time within the cycle and subsequently determining whether or not fertilization has occurred. Before the procedure begins to yield positive results, however, much preliminary work is necessary. A subject may be allowed to mate only once during a cycle which means that several weeks are required for each trial. As an aid at the outset to the selection of appropriate days for mating were the records of sexual behavior, from which it was possible to make a few general predictions. For example, there were several instances of failure to mate during early and late phases of the cycle and when mating did occur only at these times it was, without exception, infertile. . . . The procedure originally adopted began with a series of mating opportunities using a given female at a late, probably infertile period of the cycle, and gradually advancing (usually by 1 day) the date of mating in succeeding cycles. Thus, for example, a female was used on the twenty-fifth day of a given cycle, the twenty-fourth day of the next, and so on until a fertile mating occurred.

³ Elder, J. H., and Yerkes, R. M., "The Sexual Cycle of the Chimpanzee," *Anat. Rec.*, Vol. 67 (1936), p. 133.

Early this year results of an extensive series of controlled matings were reported which showed that the period of fertility in the typical chimpanzee cycle was between days 16 and 20. Analysis of these data showed that the time of ovulation in a given individual was closely related to length of cycle exhibited. That is, the earliest dates of fertile matings were found in subjects with the shortest cycles, the latest dates in those with long cycles. This seemed to indicate the necessity of considering each case individually, but it was also noted that ovulation always occurred during the last few days of genital swelling, irrespective of the length or regularity of cycles. This was an important confirmation of the hypothesis that the degree of swelling reflected follicular maturation. For several years this period of genital enlargement has been referred to as the follicular phase of the cycle, because it was assumed that development of follicles produced the swelling. Recently we have been able to demonstrate conclusively that the female sex hormone, estrin, is the cause of this phenomenon. When the ripened follicle bursts there is a diminution in secretion of estrin. This event is indicated externally by detumescence.

The external sign is very convenient. We cannot know from appearances whether ovulation has occurred in a given cycle—some of them probably are sterile—but *if* it has we can date it approximately. Furthermore, no ovulation could occur in the chimpanzee without the prerequisite enlargement of a follicle and the estrual swelling accompanying it.

Our menstrual histories show another significant relationship. In mature females detumescence appears 12 days before the subsequent menstrual period. The relative constancy of this period makes possible a generalized and yet more precise statement of ovulation time for all chimpanzees. The 15th day before menstruation is the time when fertility is greatest. The small deviations from this point may represent nothing more than the viability periods of sperm and ova.

The foregoing statement is in exact agreement with Knaus's hypothesis concerning ovulation time in women. The only difference is that I should prefer to make some allowance for variations until certain refinements in our technique of observations are accomplished. However, should anyone doubt that the conclusion is highly reliable my best answer is that it works. As we continue to enlarge our series of observations we are also applying the results practically in our breeding program.

Within a few weeks we were able to arrange for and, with the

coöperation of Doctor Hartman of the Carnegie Laboratories of Embryology, accomplish the recovery of a fertilized egg just after implantation. Without a sound basis for prediction we might have wasted months or years on such a task.

What is the significance of this work with apes in solving human problems? For those who are reluctant to make direct comparisons two suggestions may be offered. The results with monkeys and apes strongly indicate the desirability of more accurate and extensive recording of data relating to the sex life of an individual. Predictions cannot be made from scanty histories; they can and are being made accurately from good records.

It may be argued that women, because of an infinitely more complex mode of life, show greater irregularity than other primates under the relatively uniform conditions of captivity. This may be true but it is not a sound reason for neglecting the problem of accurate recording.

Since the chimpanzee exhibits striking overt effects of the follicular hormone, estrin, it seems rather odd that no signs whatever are to be found in women. The hormone is present. It appears and disappears as a result of the same process. And it produces internal changes which are much the same. Perhaps there is some clue which has been overlooked. Even though it is not obvious there may be a relatively simple means of detecting it.

Investigation is now in progress in a few laboratories on the measurement of differences in electrical potential associated with the ovulatory process. Similar attempts are being made with chimpanzees at the Yale Laboratories (Finch, Yerkes, Elder). There are certain technical difficulties which have led to some equivocal results but these will be overcome eventually. The possibility of detecting ovulation by a method almost as simple as that of taking temperature or pulse readings is truly a cause for speculation on the sociological consequences apart from scientific achievement.

BIBLIOGRAPHY

1. YERKES, R. M., and ELDER, J. H. "The sexual and reproductive cycles of chimpanzee," *Proc. Nat. Acad. Sci.*, Vol. 22 (1936), pp. 276-283.
2. ALLEN, E., DIDDLE, A. W., BURFORD, T. H., and ELDER, J. H. "Analyses of urine of the chimpanzee for estrogenic content during various stages of the menstrual cycle," *Endocrinology*, Vol. 20 (1936), pp. 546-549.
3. YERKES, R. M., and ELDER, J. H. "Oestrus, receptivity, and mating in chimpanzee," *Comp. Psychol. Monog.*, Vol. 13 (1936), No. 5, pp. 1-39.

4. ELDER, J. H., and YERKES, R. M. "The sexual cycle of the chimpanzee," *Anat. Rec.*, Vol. 67 (1936), pp. 119-143.
5. FINCH, G., YERKES, R. M., and ELDER, J. H. "Bodily electrical potential changes associated with ovulation and early pregnancy in the chimpanzee," *Proc. Soc. Exp. Biol. Med.*, Vol. 37 (1937), pp. 560-563.
6. ELDER, J. H. "The time of ovulation in chimpanzees," *Yale J. Biol. Med.*, Vol. 10 (1938), pp. 347-364.
7. ———, "Effects of theelin injections in normal prepubescent chimpanzees," *Anat. Rec.*, Vol. 72 (1938), pp. 37-43.
8. ELDER, J. H., HARTMAN, C. G., and HEUSER, C. H. "A ten and one-half day chimpanzee embryo, 'Yerkes A.,"' *J. Amer. Med. Assn.*, Vol. 111 (1938), pp. 1156-1159.

HOLOTHURIANS FROM BISCAYNE BAY, FLORIDA

ELISABETH DEICHMANN

Museum of Comparative Zoology, Harvard University

The *Holothurians* collected from Florida in earlier days lack accurate data as to their place of collection. In many cases the species are so widespread that this is of minor importance but in others it seems certain that some forms are restricted to distinct areas which do not overlap. This list of the species collected by an experienced naturalist as Dr. H. L. Clark, from Biscayne Bay in April, 1937, is therefore not without interest—especially when supplemented with exact information about color, frequency, habitats, etc. The circumstances under which the individual species were secured are mentioned under "Biological Notes" contributed by Doctor Clark.

The sixteen species are listed in the same order as in Deichmann¹ and Clark.² All other references to literature are omitted except in one or two cases. The locality for all the species is Biscayne Bay, Florida.

KEY TO THE HOLOTHURIANS FROM BISCAYNE BAY, FLORIDA³

1. Tentacles shield-shaped or pinnate; sand-eating forms 2
1. Tentacles dendritic; plankton feeders. Order Dendrochirota 9
2. Tentacles broad shield-shaped; feet numerous. Order, Aspidochirota 3
2. Tentacles pinnate or feather-shaped; feet totally lacking. Order, Apoda 14
3. Five huge anal teeth; spicules irregular rods or rosettes.
 6. *Actinopyga agassizii* (Selenka)
3. No huge anal teeth; spicules of various kinds 4
4. Spicules minute granules and C, O, or S-shaped bodies; (flanks not thickened).
 7. *Astichopus multifidus* (Sluiter)

¹Deichmann, E., "The *Holothurians* of the western part of the Atlantic Ocean," *Bull. Mus. Comp. Zool.*, Vol. 71 (1930), No. 3, pp. 41-219, pls. 1-24.

²Clark, H. L., "A Handbook of the Littoral *Echinoderms* of Porto Rico, etc.," *Sci. Surv. Porto Rico and the Virgin Islands*, (New York Acad. Sci.), Vol. 16 (1933), pt. 1, pp. 1-143, pls. 1-7.

³The number in front of each species refers to explanatory notes to be found at the end of the key.

4. Spicules not minute granules 5
5. Spicules small rosettes often distinctly in heaps and a varying number of tables with few, large conical teeth on the spire. Ventral feet, dorsal papillae; color varying from mottled to almost black.
 5. *Holothuria floridana* Pourtalès
5. Spicules not small rosettes 6
6. Spicules a crowded layer of tables with small disk and tall spire with few large, conical teeth on the top; besides large rods with incised edges. Feet not numerous on the ventral side, dorsal papillae scattered; color brownish-purplish; tentacles and tip of feet usually pale yellow.
 3. *Holothuria surinamensis* Ludwig
6. Spicules tables and buttons 7
7. Smooth buttons with mostly 3 pairs of large holes; tables with 8 regular large marginal holes, spire well developed. Slender form with few feet and papillae, the latter often contracted to warts; skin rough to the touch; color mottled gray or brown.
 4. *Holothuria impatiens* (Forskål)
7. Buttons mostly knobbed; tables in varying number and of varying degree of development 8
8. Huge tack-like tables with conical spire in base of feet; smaller irregular tables with low spire in varying number; buttons knobbed, irregular, often incomplete. Feet and papillae numerous; color dark with a light ring around base of appendages.
 2. *Holothuria princeps* Selenka
8. No tack-like tables; numerous tables, mostly with well developed low spire, which often form a hemispherical mass; buttons regular, mostly strongly knobbed. Feet and papillae small, not prominent; skin rigid with spicules; color white, or with a thin layer of brown pigment.
 1. *Holothuria cubana* Ludwig
9. Tentacles 10, the ventral ones often smaller11
9. Tentacles more than 10, of different size12
10. Spicules huge perforated plates; introvert with rosettes.
 12. *Thyone cognata* (Lampert)
10. Spicules not as perforated plates11
11. Spicules regular knobbed buttons, and small baskets in the outer layer. Calcareous ring low.
 13. *Thyone surinamensis* Semper
11. Spicules few tables, often lacking, and oblong supporting tables and end plate in the feet, calcareous ring high with short posterior prolongations. Feet numerous; color olive green or brown.
 11. *Thyone briareus* (Lesueur)

12. Five small tentacle pairs of equal size, alternating with five large pairs. Tables four-pillared; introvert with rosettes; tentacles with small rods and rosettes.

8. *Euthyonidium seguroensis* (Deichmann)

12. Tentacles of unequal size and in varying number, not regularly alternating in size13
 13. Long posterior prolongations on the calcareous ring; spicules oval tables with two lateral and three triangular terminal holes in each end; tentacles with rosettes and delicate rods.

9. *Phyllophorus destichadus* Deichmann

13. Short posterior prolongations on the calcareous ring; spicules oblong two-pillared tables with a varying number of holes in the disk.

10. *Phyllophorus parvus* (Ludwig)

14. Spicules wheels in numerous heaps and curved rods thinly scattered.

16. *Chiridota rotifera* (Pourtalès)

14. Spicules anchors and anchor plates15

15. Spicules large anchors and anchor plates (0.3-0.6 mm. long).

14. *Leptosynapta multigranula* Clark

15. Spicules small anchor and anchor plates (0.11 mm. long).

15. *Leptosynapta parvipatina* Clark

NOTES:

1. *Holothuria cubana* Ludwig.

Deichman,⁴ Clark.⁵ Five good typical specimens, ranging from 4 to 12 cm. in length.

BIOLOGICAL NOTES.—Found under sponges, rock fragments, or patches of coral, more or less buried in the sandy mud.

2. *Holothuria princeps* Selenka.

Deichmann,⁶ Clark.⁷ One large well preserved specimen measuring over 30 cm. in preserved condition.

BIOLOGICAL NOTES.—A very striking holothurian in life owing to the large size 35-40 cm., the numerous large, more or less conical appendages, and the variegated brown and yellowish coloration. The only specimen seen was brought into the laboratory of the University of Miami. It was reported that it was found on the grassy flat in shallow water near the southwest corner of Virginia Key.

⁴ *Op. cit.*, p. 54, pl. 3, figs. 1-8.

⁵ *Op. cit.*, p. 100.

⁶ *Op. cit.*, p. 58, pl. 2, figs. 1-8.

⁷ *Op. cit.*, p. 101.

3. *Holothuria surinamensis* Ludwig.

Deichmann,⁸ Clark.⁹ Three large specimens prove that this widespread species does actually occur in Florida. Hitherto the only specimens in any collection examined was one of the types of "*H. subditiva*" Selenka, which was stated to come from "Florida."

4. *Holothuria impatiens* (Forskål).

Deichmann,¹⁰ Clark.¹¹ One specimen of this widespread species.

BIOLOGICAL NOTES.—Found on the flat near the northwestern corner of Biscayne Key.

5. *Holothuria floridana* Pourtalès. Figs. 1-8.

Deichmann,¹² Clark.¹³ A large number of individuals (27) ranging in size from a few centimeters to about 15 cm. in length (in preserved condition) were secured. Their coloring shows the usual diversity, from brightly mottled, with or without large black patches, to almost completely black. Examination of the spicules showed that the specimens all belonged to the same species; in the smallest specimen the rosettes were, however, extremely rare. The complete absence in the collection of the other species which resemble this form, viz., *H. mexicana* (reported from Tortugas), and *H. grisea* (one specimen reported from Florida, possibly wrongly identified), seems to indicate that the presence of *floridana* in a locality excludes the two other species.

BIOLOGICAL NOTES.—Widely distributed on "grassy" bottom on the east side of the bay in very shallow water.

6. *Actinopyga agassizi* (Selenka)

Deichmann,¹⁴ Clark.¹⁵ Two specimens were preserved, one yellowish mottled and about 5 cm. long and one more darkly colored, about 10 cm. long, strongly contracted.

BIOLOGICAL NOTES.—One of the commonest holothurians on the grassy flats in shallow water near the keys. Almost always accompanied by the symbiotic fish *Fierasfer*. The largest *Actinopygas* are fully 30 cm. long when alive.

⁸ *Op. cit.*, p. 63, pl. 3, figs. 12-15, 19.

⁹ *Op. cit.*, p. 105.

¹⁰ *Op. cit.*, p. 64, pl. 3, figs. 17-18.

¹¹ *Op. cit.*, p. 102.

¹² *Op. cit.*, p. 72, pl. 5, figs. 5-9.

¹³ *Op. cit.*, p. 107.

¹⁴ *Op. cit.*, p. 78, pl. 5, figs. 21-29.

¹⁵ *Op. cit.*, p. 108.

7. *Astichopus multifidus* Sluiter.

Deichmann,¹⁶ Clark.¹⁷ Three large specimens, up to 20 by 8 cm. in contracted condition were preserved. Hitherto this characteristic species was reported only from the Tortugas and Jamaica.

BIOLOGICAL NOTES.—While collecting on a grassy flat on the east side of the northwestern end of Key Biscayne (southeast of Bear Cut), a small boy, Peter Mills, who was working with us, found 4 specimens of the remarkable holothurian. The specimens measured 20-30 cm. in length and about 4 cm. in diameter; the body was somewhat flattened and *Stichopus*-like and the collar around the tentacles was very marked as were the numerous more or less conical appendages. The body wall was very thick and rather soft, with the appendages quite flaccid. In color, the upper surface was brownish-yellow, much variegated; the conspicuous collar and tentacles were white as was the whole lower surface, whereas the pedicels were pale pink and there were blackish spots scattered here and there among them of varying number and size in the different individuals. Three of the individuals eviscerated before they reached the laboratory.

Euthonidium Deichmann.¹⁸

DIAGNOSIS.—Tentacles, five large pairs alternating with five very small pairs. Calcareous ring high with short indistinct posterior prolongations. Spicules, tables with regular round to squarish disk and four pillars in spire. Feet with distinct end plates; introvert with smaller, more irregular tables and rosettes; tentacles with delicate rods and rosettes.

TYPE SPECIES.—*E. seguroensis* (Deichmann)

TYPE LOCALITY.—Porto Seguro, Brazil.

DISTRIBUTION.—Brazil, Jamaica, Florida.

DEPTH.—Shallow water to few fathoms depth.

REMARKS.—The genus seems to be intermediate between *Phyllophorus* and *Euthonidium*. At the present moment only two species are included in the genus, but probably other tropical species may be transferred to it.

8. *Euthonidium seguroensis* (Deichmann). Figs. 9-14.

Phyllophorus seguroensis Deichmann,¹⁹ Clark.²⁰ Three typical specimens. Formerly this species was known from Porto Seguro, Brazil, Jamaica, and Tortugas.

¹⁶ *Op. cit.*, p. 84, pl. 5, figs. 44-47.

¹⁷ *Op. cit.*, p. 110.

¹⁸ Deichmann, E., "Zaca' Holothurians," *Zoologica*, Vol. 23 (1938), No. 18, pp. 361-87.

¹⁹ *Op. cit.*, p. 141, pl. 17, figs. 10-13.

²⁰ *Op. cit.*, p. 111.

BIOLOGICAL NOTES.—These individuals were dug from sandy mud on the "grassy" flat south of Cape Florida.

9. *Phyllophorus destichadus* Deichmann. Figs. 15-18.

Deichmann,²¹ Clark.²² One specimen, about 4 cm. long, with the anterior end retracted. This is the first record since the type and paratypes were discovered at Tortugas. It agrees well with the type. The tables in the skin are somewhat more delicate than that figured by Deichmann.

BIOLOGICAL NOTES.—Found among eelgrass roots with the preceding species but recognized at once as different from it.

10. *Phyllophorus parvus* (Ludwig). Figs. 19-21.

Thyonidium parvum Ludwig.²³

Phyllophorus parvus, Deichmann,²⁴ Clark.²⁵

DIAGNOSIS.—Small form (length 5-8 cm.) with about 20 tentacles of different size irregularly alternating; feet small, scattered and in indistinct bands along the ambulacra. Calcareous ring tall with long, narrow posterior prolongations. The spicules form a crowded layer of tables with oblong disk with smooth margin and a varying number of holes irregularly distributed, usually eight or ten; spire low, with two pillars and about eight short spines. In the feet a large end plate, often composed of several pieces and a few supporting tables; sometimes completely lacking; tentacles soft with few delicate rods, often with forked or perforated ends.

TYPE.—Possibly found in Germany.

TYPE LOCALITY.—"Coast of Brazil," (van Beneden coll.).

DISTRIBUTION.—Ranges from Brazil to Antigua and Florida; shallow water.

DEPTH.—Low water mark to few fathoms.

SPECIMENS EXAMINED.—One specimen from English Harbor, Antigua (Iowa Expedition, W. K. Fisher coll.), three from Biscayne Bay (H. L. Clark coll., April, 1937).

REMARKS.—The species belongs definitely to the genus *Phyllophorus* as defined by Sars (type species *P. urna*). It has the characteristic long slender tentacles arranged in one or two irregular circles and of very varying size, not alternately large and small as in the typical *Thyonidium*.

²¹ *Op. cit.*, p. 146, pl. 18, fig. 3.

²² *Op. cit.*, p. 112.

²³ Ludwig, H., "Über eine lebendige gebärende *Synaptide*, etc.," *Arch. Biol.*, Vol. 2 (1881), p. 54, pl. 3, figs. 16-19.

²⁴ *Op. cit.*, p. 149.

²⁵ *Op. cit.*, p. 113.

The specimens from Florida are considerably larger than those previously known. In the largest specimen the tentacles are expanded and the lack of a distinct introvert is noticeable; the feet extend almost to the base of the tentacles. The color of the preserved specimens is bright brown with a reddish cast.

BIOLOGICAL NOTES.—In life the most striking feature of these *holothurians* was the uniform crimson color, including the tentacles; four specimens were seen and all agreed exactly in this unusual coloration. While the color seemed crimson to me (H. L. C.), others thought it had a tinge of brown, so it was probably not so bright a red as it seemed to me.

All of the specimens were dug out of the sandy mud, on the "grassy" flat south of Cape Florida (Key Biscayne's southern tip), in very shallow water. The living animals ranged from 5-8 cm. in length with tentacles retracted. After being narcotized with epsom salts, one of the larger specimens expanded its tentacles and was preserved in weak alcohol without retraction. The preserved specimens were noticeably more slender than they were in life.

11. *Thyone briareus* (Lesueur).

Deichmann,²⁶ Clark.²⁷ Two small specimens (2-3 cm. long) were secured. They were yellowish brown and had very few spicules left, save the characteristic elongate supporting tables in the feet and the end plates. They agree in all essentials with specimens of similar length collected at Woods Hole, Massachusetts, and represent specimens 2-3 years old, unless growth is more rapid in the warmer waters of Florida.

This species is known only from the south and east coasts of North America proper, ranging from Texas to Massachusetts. It is a regrettable error when Deichmann²⁸ states that the type locality is St. Bartholomew in the Lesser Antilles—the type locality for most of Lesueur's species, for the type came from Florida.

BIOLOGICAL NOTES.—These specimens were dug close to the area where *Leptosynapta micropatina* was taken, at Cocoplum Beach, on the west side of Biscayne Bay.

12. *Thyone cognata* (Lampert).

Deichmann²⁹ (erroneously quoted from Théel as *cognita*) Clark,³⁰ Seven specimens of medium size, averaging 6 cm., were collected. One was pure white while the others were pale reddish brown, mottled and with a few specks of black scattered on both ventral and dorsal sides. The

²⁶ *Op. cit.*, p. 165, pl. 13, figs. 5-7.

²⁷ *Op. cit.*, p. 113.

²⁸ *Op. cit.*

²⁹ *Ibid.*, p. 169, pl. 15, figs. 1-4.

³⁰ *Op. cit.*, p. 115.

specimens agree well with the material previously examined from Porto Seguro, Brazil, Yucatan, and Tortugas. Apparently a fairly common form.

BIOLOGICAL NOTES.—This specimen is quite common on the "grassy" flat south of Cape Florida, where it buries among the "eelgrass" roots.

13. *Thyone surinamensis* Semper.

Deichmann,³¹ Clark.³² A single small specimen was secured, unusually strongly elongated. This seems to be the first authentic record of this species from Florida, although it is known to range from Brazil, the Lesser Antilles to Bermuda.

BIOLOGICAL NOTES.—This specimen was dug at Cocoplum Beach, in the same "eelgrass" patch as *Thyone briareus*.

14. *Leptosynapta multigranula* Clark.

Deichmann³³ (erroneously called *multigranulata*), Clark.³⁴ One typical but small specimen was collected. Hitherto it was known only from Tortugas.

BIOLOGICAL NOTES.—This young individual was dug from among "eelgrass" roots on the flat south of Cape Florida. It was scarcely 4 cm. long in life. The color was pinkish.

15. *Leptosynapta parvipatina* Clark.

Leptosynapta parvipatina Clark.³⁵ ³⁶

Leptosynapta micropatina Heding.³⁷

Numerous specimens were dug at Cocoplum Beach, near Miami. They agree in all details with the specimens collected at Tobago, B. W. I., the type locality for both Clark's and Heding's material.

The species is, as noticed by Heding,³⁸ closely related to *L. tenuis*, the common form in Woods Hole. It seems to be a much smaller species

³¹ *Op. cit.*, p. 173, pl. 16, figs. 5-8.

³² *Op. cit.*, p. 116.

³³ *Op. cit.*, p. 207.

³⁴ *Op. cit.*, p. 119.

³⁵ Clark, H. L., "The *Holothurians* of the Museum of Comparative Zoology, the *Synaptinae*," *Bull. Mus. Comp. Zool.*, Vol. 65 (1924), p. 490, pl. 4, fig. 30.

³⁶ Clark, H. L., "A Handbook, etc.," *Sci. Surv. Porto Rico and the Virgin Islands*, (1933), p. 120.

³⁷ Heding, S. G., "Synaptidae; papers from Dr. Th. Mortensen's Pacific Expedition 1914-16, No. 46," *Vid. Med. Dansk. Nat. For.*, Vol. 85 (1928), p. 213, fig. 30.

³⁸ *Ibid.*, p. 215.

(length about 5-6 cm. as contrasted with 30 cm. in the Woods Hole form) and the number of sensory cups is smaller (4-7 as contrasted with 15-25 in large *L. tenuis*); also the anchors and anchor plates are definitely smaller and the tentacle rods smaller and more deformed than in the northern species. However, a more complete series of specimens from various localities between Florida and Woods Hole may show that the two species are not sharply set off from each other.

16. *Chiridota rotifera* (Pourtalès).

Deichmann,³⁹ Clark.⁴⁰ Five small specimens of this species, which is so common in Florida, the West Indies, and Bermuda, were collected.

BIOLOGICAL NOTES.—Dug from among "eelgrass" roots, on the flats south of Cape Florida.

EXPLANATION OF FIGURES

Holothuria floridana Portalès

- 1-2. Tables of young individual.
- 3-4. Rosettes, usually complex.
- 5-6. Tables of adult individual.
- 7-8. Rosettes, typical shape.

Euthyonidium seguroensis (Deichmann)

- 9-10. Disks of tables.
- 11. Tip of spire of table.
- 12. Table from introvert.
- 13. Supporting rod.
- 14. Rosette.

Phyllophorus destichadus Deichmann

- 15-17. Disks of tables.
- 18. Spire of table.

Phyllophorus parvus (Ludwig)

- 19-21. Disks of tables.
- 22. Spire of table, seen from above.
- 23. Supporting table from feet.
- 24. Rods from tentacles.

³⁹ *Op. cit.*, p. 212.

⁴⁰ *Op. cit.*, p. 122.

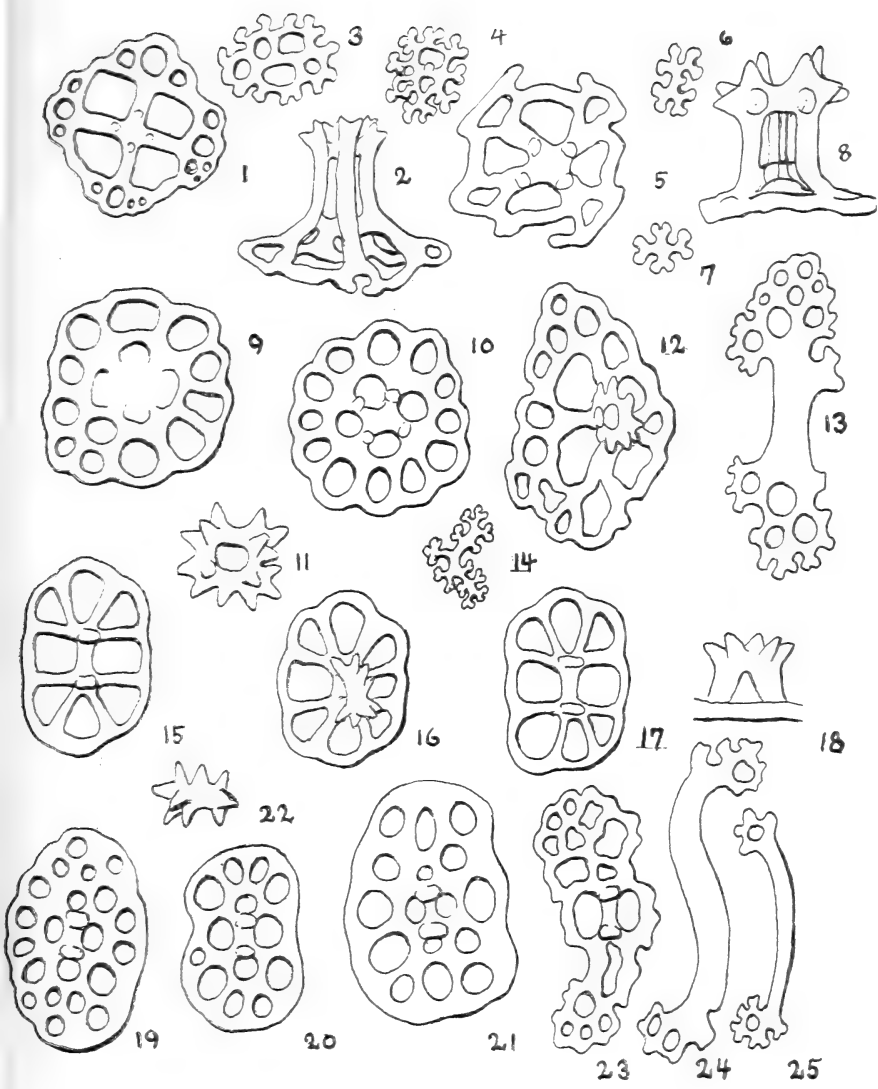

Each division = .01 mm.

ABSTRACTS

THE AUSTIN CARY MEMORIAL DEMONSTRATION FOREST

H. S. NEWINS
University of Florida

This tract of 1519 acres in Alachua County was augmented by 564 additional acres in 1937 and 1938, for the purpose of a field laboratory of the School of Forestry of the University of Florida. Its location 10 miles distant from the campus on State Highway 13 makes it convenient for regular field class work. Curricula are offered for rangers or semi-professional students, as well as for the four year degree. The forest was named for Dr. Austin Cary, pioneer developer of forestry in the South, who died at the University of Florida in 1936. In addition to development by the State of Florida, the Works Progress Administration has assisted in the establishment of roads, telephone lines, etc. A forty-acre plot is allowed to undergo the ordinary fire hazards, but elsewhere there is protection.

Activities relating to the extra-curricular phase of the Demonstration Forest involve the disposal of thinning timber, naval store products and small-scale sawmill operation. Game management is also a part of the work, and there are tests conducted for timber preservatives, grazing experiments and termite investigations.

THE VITAMIN C CONTENT OF GRAPEFRUIT UNDER RETAIL MARKETING CONDITIONS

R. V. HARRISON
Miami

Tests were made upon 2 dozen ordinary Florida grapefruit, half of them exposed to strong sunlight and half protected from exposure. One each was tested daily for Vitamin C content by the method of J. W. Stevens (*Industrial and Engineering Chemistry, Analytical Edition*, May 1938, page 269). In all tests made it was found that the blossom end of the specimens contained less Vitamin C than the stem end. Fruit is not necessarily lacking in Vitamin C because it is not sweet. Although not exhaustive enough to warrant definite conclusions, it seems apparent from these experiments that grapefruit marketing conditions as practiced do not materially detract from the content of the antiscorbutic vitamin.

NOTES ON THE HISTOLOGY OF *SIREN*

GEORGE G. SCOTT
Winter Park

These animals are commonly known as "mud-eels" indicative of their environment. In Florida, I have heard them called "lamper-eels" and that they are poisonous. "Lamper-eel" is probably a colloquial expression for "lamprey-eel." However, lampreys belong to an entirely different class and moreover *Siren* is not poisonous. It is a large aquatic caudate amphibian, about thirty inches long, having a body diameter of well over two inches, with a long vertically disposed tail.

When handled great quantities of mucous are exuded from the skin. Throughout life it has external gills which are probably the chief organs of respiration but at the same time it has a pair of attenuated lungs extending the length of the body cavity. Frogs have external functional gills in the tadpole stage only. Specimens of *Siren* were obtained from Lake Virginia, in Winter Park. Studies in the structure of the organs were made for purposes of comparison with the microanatomy of other Amphibia. Reference in this paper is made to the structure of the skin, gill, tongue, thyroid gland, oesophagus, stomach, small intestine, large intestine, trachea, lung, oviduct, ureter and bladder. The structure of the mucosal lining of the intestine is of especial interest. In mammals this consists of but *one* layer of cells through which digested substances pass from the lumen into the blood stream. A similar construction appears to be the rule in other vertebrates. However, in *Siren*, the mucosal layer consists of *many layers* of very small cells so that one is even more puzzled to explain how absorption takes place through it. Correlating structure with function, observations usually tend toward the conclusion that a many layered epithelium occurs where for the best interests of physiological well-being, absorption should not take place.

THE EXPERIMENTAL TECHNIQUES OF SCIENTIFIC
PSYCHOLOGY VERSUS THE SPECULATIVE
DOGMAS OF EDUCATIONAL PSYCHOSOPHY

CHRISTIAN PAUL HEINLEIN
Florida State College for Women

Psychology conceived as the study of psychophysical relationships is scientific in so far as the data of observation are verifiable by experimental techniques which provide for isolation of factors, measur-

able control of variables identified perceptually as qualitatively homogeneous, provision for repetition of conditions within the limits recorded, and mathematical or symbolic representation of data recorded. Such experimental techniques provide the means for systematic organization, univalent classification and sound logical interpretation. During the last twenty years, psychological laboratories throughout the world have contributed a vast fund of scientific knowledge in the neuro-muscular and sensori-motor fields.

By contrast with scientific psychology, I list under the phrase "educational psychosophy" the most widely taught pseudo-scientific techniques and quasi-measurements as they are applied in college courses of so-called "Educational Psychology." In educational psychology we find repeated attempts to describe and to measure such imaginary forces and abstractions as *intelligence, personality, character, the Will, instincts, conditioned reflexes*, and the persistent superstitions called *nature* and *nurture*. Educational psychology has no *raison d'être* other than the familiar administrative propaganda of "adjectival adoption" through professional proclamation. Historically and developmentally, educational psychology is an artificial branch of applied psychology heavily loaded with rational speculation, dogmatic assumptions arbitrarily termed "laws," and questionable educational devices proclaimed "scientific" by virtue of authority. Reasons for the recurrence in texts of educational psychology of such medieval dogmatism, mysticism and anti-scientific bias are pointed out in this paper.

RESONANCE IN THE TELEPHONE AND IN THE COCHLEA

MAX F. MEYER
University of Miami

The mammalian organ of auditory perception consists of thousands of microphones, hair cells (piezoelectric microphones), all joined together to form a lamella. Can one discover resonance in this lamella? During half a century about fifty-seven experiments have been made on living animals with the preconceived and single purpose to prove that there is some resonance in that lamella. It is no wonder that some of the experimental results seemed to prove it. Even without those experiments one can admit that there is some resonance present. But the cochlea is a tube filled with very watery glue, which undulates under the restraint of the lamella in the direction of its two surfaces. The undulating liquid divided by the lamella presents

a hydraulic problem. Not one of the fifty-seven experimenters honestly tried to think out the hydraulic function and to make clear to himself that this and not the resonance was the essential thing. They kept their thinking outside of the hydraulic function, confined there by a dogmatic belief that resonance was the essence of the cochlea, its reason for existence. It is my hope that this dogma will not live to celebrate its centennial.

I said "by a dogmatic belief" and must add "during the last dozen years also by the popularity of that slogan which considered place and frequency as opposite notions." It is unfortunate that not one of the physiological experimenters recognized the phrase "place versus frequency" as what it is, a slogan, not a plan capable of guiding biological thought.

If we free ourselves from the belief in resonators as being the essence of the cochlea, and also from the uncritical acceptance of the slogan "place versus frequency" we recognize that the real problem is to discover how the lamella on which the cochlear microphones (the hair cells) are standing moves under the hydraulic influence of the surrounding liquid. I assert that when that hydraulic problem is perfectly solved, the sound analysis by the cochlea will be perfectly understood.

THE BASAL METABOLISM OF COLLEGE WOMEN AS INFLUENCED BY RACE AND DEGREE OF ACTIVITY

LOLA SCHMIDT AND JENNIE TILT
Florida State College for Women

Tests made upon female students under basal conditions indicate distinct racial differences in metabolic activity. White subjects ranged in age from 17 to 21 years, apparently normal as to health. Colored subjects were from 18 to 23 years. Using a Benedict-Roth apparatus the white subjects showed an average B. M. R. of -11.6% for the Physical Education (most active) group, and -13.0% for the Chemistry (less active) group. The negro group's average was -12.0 .

SUGGESTIONS CONCERNING THE TEACHING OF
BIOLOGYGEORGE G. SCOTT
Winter Park

In large institutions where many phases of Biology are presented it is the opinion of the writer that more effective work can be accomplished if all the courses are brought together and administered as one department of Biology, with a number of subdivisions such as Botany, Zoology, Physiology or even Embryology, Genetics, etc., each in charge of a competent head who will develop them properly.

One of the principal matters discussed in this paper is the nature of the course in General Biology. It is suggested that the teacher become familiar with the classification of Biological Sciences as adopted by *Biological Abstracts*; thoughtfully consider the wide field of knowledge covered in this periodical survey; plan his own course; make his own syllabus of lectures and laboratory exercises; determine which subjects should be stressed more than others; in what order they should be introduced; how much time may be devoted to each; which may be most satisfactorily handled in the laboratory with the facilities at hand.

The teacher should be ever mindful of the materials and equipment needed for most effective teaching; he should always impress upon students that a laboratory is a place where work is to be done not merely for the sake of keeping busy, but where building is going on, and that this work should begin promptly the first time the class meets and that outside interests should not be permitted to interfere with the progress of the building process.

The operation of a good biological laboratory in actual class use is one of the most difficult of the entire curriculum. How much easier is the physical manipulation of the teacher of history or languages! The biologist on the other hand has not only a wide assortment of materials and equipment peculiar to his own subject, but many things of the chemist and physicist as well as reference books which seem to be the sole equipment of the teacher of history, for example.

The field of Biology is today so vast that proper selection of just what should be presented is difficult. But it would make for real education of the teacher if he were to attack the problem boldly in a common sense way and experiment with it, remembering, however, that whatever he does decide to present should be done thoroughly.

The question is often raised as to whether the graduate schools are training teachers properly. It is claimed by some that the tendency of the graduate school is toward narrow specialization; that emphasis on research makes for poor teaching later and that the graduate schools should deliberately do something concrete about training teachers. Those who have been successful investigators in this or that phase of science are convinced that research accomplishments make for better teaching.

The present writer advances the suggestion that the first part of the graduate training be a thorough survey of the whole field of the science in question, that the problems assigned for research be very carefully considered and that they possess a strong probability of solution with the facilities at hand or possible of procuring or producing, and within a reasonable period of time. It should also be considered that good teachers are born that way. Furthermore, while the pursuit of science for its own sake is a worthy occupation, is it not incumbent upon every teacher of science to recognize his social responsibility?

MENTAL HYGIENE IN SECONDARY EDUCATION

W. L. MACGOWAN

Lee High School, Jacksonville

Health implies normal functioning of body and mind in their full vigor. Since health is fundamental to success in life it should receive at least as much attention as any traditional subject of the curriculum. The consideration of mental health cannot in practice be separated from that of physical health, but since mental hygiene is a comparatively new field and its techniques little known to the average teacher, a campaign of education and training is needed for educators.

Mental hygiene implies individual guidance rather than mass instruction, and not only provides for aiding the normal child in developing a well-integrated personality, but furnishes the key to the problem of delinquency. It is destined therefore to assume an increasing importance in the educational program. Vocation and recreation must also be considered in relation to individual development.

The activities by which students may observe, analyze and develop their personalities often bring unexpected results of value. Teachers mature emotionally as they become more familiar with the marks of maturity and tend to follow in their own living the behavior pat-

terns which they have been teaching. The students' personality profile of the teacher, usually dreaded by the teacher at first, turns out to be a valuable means of diagnosing the individual student. A student who is an usher in a theatre tries the effect on his patrons of treating each one with punctilious deference and care. He finds that 80% respond favorably, but he also finds to his surprise that he has a much greater interest in his job and that he makes many personal friends as a result of his experiment.

Improvement and integration of the personality result not from studying a body of subject matter in the traditional course of study, but from living experiences illuminated by significant knowledge.

There is a rapidly increasing interest in mental hygiene, and the need arises of pooling experiences so that educators can be more quickly and effectively trained in this important field.

PSYCHOMETRIC RESULTS AND NOTES ON BEHAVIOR BEFORE AND AFTER A PREFRONTAL LOBOT- OMY ON A MENTAL PATIENT

PHILIP WORCHEL

Florida State Hospital, Chattahoochee

Prefrontal lobotomy consists of cutting the association fibers in the white matter of the prefrontal lobes of the cerebrum. It is utilized as a means of successfully combatting extremes of depression, worry, agitation and other psychoses in such states as involutional melancholia and manic-depressive insanity. The present study deals with the effect of this treatment on the general behavior, especially as to personal and social adjustment; and also it attempts to extend the knowledge regarding the function of the prefrontal lobes. The case report cited describes a 47-year white female, mentally depressed. After prefrontal lobotomy her subjective condition was markedly improved, and psychometric tests showed slight, but consistently bettered mental condition when repeated after an interval of 10 months.

CONDITIONS FOR ALGEBRAIC SOLUTIONS OF CERTAIN ORDINARY DIFFERENTIAL EQUATIONS OF FIRST ORDER AND FIRST DEGREE

BARBARA DAVIS

Apopka

This paper deals with equations of the type $Mdx + Ndy = 0$ where M and N are both linear or both quadratic polynomials. The problem is to find the conditions under which the solutions of the differential equation are algebraic functions.

Part I discusses the linear type

$$(a_1x + b_1y + c_1)dx + (a_2x + b_2y + c_2)dy = 0$$

under two divisions according as the determinant $a_1b_2 - a_2b_1$ is equal or unequal to 0. In the special case of the exact differential equation the solutions are algebraic and are, in fact, conics with axes $M = 0$ and $N = 0$.

Part II discusses certain cases of the quadratic type. These are: the cases in which M and N are respectively functions of x and of y or of y and of x , the homogeneous exact case, and the non-homogeneous exact case. In the non-homogeneous exact case geometric relations between M and N and the derived solution curves involving the Jacobian of M and N and the Hessian of the derived integral curves are discussed.

THE S-H FREQUENCY OF THE MERCAPTANS

DUDLEY WILLIAMS

University of Florida

Inasmuch as this paper, prior to its presentation at the Annual Meeting, had already been published, in *The Physical Review*, Vol. 54, No. 7 (Oct. 1938), pp. 504-5, its abstract is here omitted.

SUGGESTIONS FOR AN IMPROVED NOTATION IN TRIGONOMETRY

H. H. GERMOND

University of Florida

The designations sine, cosine, etc., at present used in trigonometry are not readily learned by many students; part of this difficulty may be traced to the fact that these designations fail to carry any meaning in themselves so far as the student is concerned. Two other types of designation for these functions are suggested in this paper. In one of these the student would first learn the functions in terms of

the sides and hypotenuse of a right triangle, with base labeled b , the side at right angles to it labeled s , and the hypotenuse (or "long side") labeled l . Then the function now known as the tangent of the acute angle adjacent to b would be known as the side-over-base of A , which would be abbreviated: *sob* A . The other type of designation differs but slightly from this.

THE NEUTRON

D. C. SWANSON
University of Florida

The existence of the neutron was shown by Chadwick in 1932. Since its discovery a considerable amount of work has been done on its interaction with matter and as a consequence many of its properties are familiar. Until recently^{1 2} no attempt has been made to study fast neutron scattering in heavy elements by determining energy distribution of the neutrons as observed from the energies of recoil protons. In these experiments neutrons were produced by bombarding a lithium target by a 1.2 MV. deuteron beam of the cyclotron. The neutron beam was collimated through a tube in a large water shield 25 cm. thick. Effectiveness of such a shield is readily noted by examining photographs of recoils produced with the chamber in front of the collimator and also behind the water shield. Photographs for the recoil protons produced in the cloud chamber by the neutrons were taken as follows:—first, when the cloud chamber was placed in front of the collimator with no scatterer; second, with the 4.8 cm. of lead inserted in the collimator between neutron source and cloud chamber. An examination of the results shows that in the direct beam with no lead scatterer half of the neutrons have an energy greater than 3 MV. while with the lead scatterer only one-third of the neutrons have an energy greater than 3 MV. From this it is evident that the energy distribution has been considerably changed by the presence of the scatterer and this points to a large energy loss by the neutron when scattered. It is probable that the large shift in energy distribution is due chiefly to inelastic scattering and consequently a large loss of energy by the fast neutrons.

¹ Bacher, R. F., and Swanson, D. C., "The scattering of fast neutrons," *Bull. Amer. Phys. Soc.*, Vol. 13 (1938), No. 1, p. 12.

² ———, "On the scattering of fast neutrons," *Bull. Amer. Phys. Soc.*, Vol. 13 (1938), No. 2, p. 15.

AN INFRA-RED STUDY OF SEVERAL LIQUID CRYSTALS

RICHARD TASCHEK AND DUDLEY WILLIAMS

University of Florida

Inasmuch as this paper, prior to its presentation at the Annual Meeting, had already been published, in the *Journal of Chemical Physics*, Vol. 6, No. 9 (Sept. 1938), pp. 546-52, its abstract is here omitted.

THE DESIGN OF NUMERICAL PROBLEMS FOR INSTRUCTIONAL EFFICIENCY

H. H. GERMOND

University of Florida

Many of the problems normally assigned for class work or even as a part of an examination call for a considerable amount of laborious computation along lines with which the student is already familiar. Comparatively little of his time is spared for attention to the new points which the particular problem may be raising. The more laborious and time-consuming such problems are, the fewer the problems which may be assigned. If there is anything to the adage that practice makes perfect, then it is desirable to keep the incidental computational labor at a minimum in order that a maximum number of problems may be treated in the available time. This paper presents a number of aids in the design of problems in which the computational labor is held at a minimum. Some of these aids are in the nature of rules or formulas. Others are in the form of basic tables from which hundreds of different problems may be constructed. These aids are of direct use in such subjects and topics as algebra, trigonometry, the use of logarithms, statistics, and business mathematics.

SEMANTIC ANALYSIS: A BASIC STEP IN SCIENTIFIC METHOD

CHRISTIAN PAUL HEINLEIN

Florida State College for Women

Semantics is the systematic study of the evolution of meanings which language is meant to convey. If "meaning" is understood and accepted as the verifiable operations of some observable event in nature, semantic analysis then refers to the critical examination of the specific operations which are attributed by common agreement and verbal convention to a given language-sign or word-phrase.

Scientific method involves the scrupulously exact definition of observable data, properties and relations. To define is to make definite through language signs or symbols a given set of operations which can be systematically verified under certain known conditions. Definition follows a selected order of systematic observation and verification through controlled experimentation.

Descriptions ranging in scope from gross superstition to statements of concrete facts have been classified under the heading of definition. A priori hunches, tentative hypotheses and assumptions of probable occurrence are not to be confused with scientific definition. To define scientifically is to describe a system of operations which depends for its existence on the selective accumulation, organization and classification of observable data into categories wholly homogeneous with respect to the discriminatory limits of some arbitrarily chosen quality. Descriptions containing abstractions which can not be resolved into observable operations of objective data are not acceptable as scientific definitions. By means of examples, this paper points out the importance of stressing semantic analysis as a basic step in scientific training in colleges.

A NEW CONCEPT OF FLORIDA SOILS

EDWARD T. KEENAN

Keenan Soil Laboratory, Frostproof

The high silica contents of Florida soils, often running above 90%, offers a parallel to certain aspects of soil-less, or tank culture, work. Their low fertility is reflected in the less than 5% colloidal content and less than 3% base-exchange capacity. Thus, considering this as merely a supporting medium the program offered suggests many advantages to agriculture in Florida. Fruits and vegetables may be grown more nearly to specification, as has been the case in citrus culture for many years with satisfactory results.

NATURAL PHENOMENA

MARY W. DIDDELL

Jacksonville

Science in one century has accomplished more for civilization than did the total of human effort in the preceding five thousand years. Nevertheless all of man's cues have come from nature in some such forms as volcanic forces (steam production) the flight power of

birds (aviation), among numerous other similarities upon which many of our practical applications have found basis-in-fact. The are of camouflage, particularly, so useful to plants and animals is a source of never-ending wonder. Exception is taken to the view that chameleons' color changes are a sex-attraction mechanism, rather than protective. Color, as a source of sex attraction is, however, important in animal life. Interesting also is the subject of night-pollinated flowers that attract night-flying insects for this purpose, and such facts as the color attraction of various blossoms for insect pollinators, the role of fragrance and odor, the reliance of some plants on wind-pollination, and the evidences of competitiveness among plants for survival and endurance.

OFFICERS OF THE ACADEMY FOR 1938

PRESIDENT: R. I. Allen, *Stetson University*.

VICE-PRESIDENT: Charlotte B. Buckland, *Landon High School, Jacksonville*.

SECRETARY: J. H. Kusner, *University of Florida*.

ASSISTANT SECRETARY: C. I. Mosier, *University of Florida*.

TREASURER (until March 21): J. F. W. Pearson, *University of Miami*.

ACTING TREASURER (after March 21): E. M. Miller, *University of Miami*.

CHAIRMAN OF BIOLOGICAL SCIENCES SECTION: L. Y. Dyrenforth, *St. Luke's Hospital, Jacksonville*.

CHAIRMAN OF PHYSICAL SCIENCES SECTION: B. P. Reinsch, *Florida Southern College*.

CHAIRMAN OF SOCIAL SCIENCES SECTION: R. S. Atwood, *University of Florida*.

OFFICERS OF THE ACADEMY FOR 1939

PRESIDENT: B. P. Reinsch, *Florida Southern College*.

VICE-PRESIDENT: W. L. MacGowan, *Lee High School, Jacksonville*.

SECRETARY: J. H. Kusner, *University of Florida*.

TREASURER: E. M. Miller, *University of Miami*.

CHAIRMAN OF BIOLOGICAL SCIENCES SECTION: G. G. Scott, *Winter Park*.

CHAIRMAN OF PHYSICAL SCIENCES SECTION: A. A. Bless, *University of Florida*.

CHAIRMAN OF SOCIAL SCIENCES SECTION: R. S. Atwood, *University of Florida*.

LIST OF MEMBERS—1938

*Albee, Fred H., Venice (Medicine)

Allen, E. Ross, Florida Reptile Institute, Silver Springs (Herpetology)

*Allen, R. I., Stetson University, DeLand (Physics)

Anderson, G. W., 376 W. Magnolia St., Gainesville (Chemistry, Physics, Astronomy)

*Anderson, W. S., Rollins College, Winter Park (Chemistry)

*Armstrong, J. D., Box 70, Route 1, South Jacksonville (Chemistry, Physics)

*Arnold, Lillian E., Experiment Station, University of Florida, Gainesville (Botany)

*Atwood, R. S., University of Florida, Gainesville (Geography)

†Babcock, Louis, M. & T. Building, New York (Ichthyology)

*Bacon, Milton E., Jr., 2008 Riverside Drive, Jacksonville (Archeology, Geology)

*Charter Member.

†Associate Member.

- *Bahrt, G. M., P. O. Box 629, U. S. D. A. Laboratory, Orlando (Chemistry, Soils)
 Baker, Harry Lee, State Forester, Tallahassee (Forestry)
- ‡*Barbour, R. B., 656 Interlachen Avenue, Winter Park (Chemistry)
- Barrows, W. M., Florida State College for Women, Tallahassee (Physics)
- *Bass, J. F., Jr., Bass Biological Laboratory, Englewood (Marine Biology)
- *Beardslee, H. C., Altamonte Springs (Mycology)
- *Becker, R. B., Experiment Station, University of Florida, Gainesville (Agriculture)
- Becknell, Elizabeth A., 6900 Dixon Ave., Tampa (Psychology)
- *Becknell, G. G., University of Tampa, Tampa (Physics, Mathematics)
- *Bell, C. E., Experiment Station, University of Florida, Gainesville (Chemistry, Soils)
- Bellamy, R. Edward, 808 N. Jefferson St., Albany, Ga. (Biology)
- *Bellamy, R. F., Florida State College for Women, Tallahassee (Sociology)
- *Berger, E. W., Experiment Station, University of Florida, Gainesville (Entomology)
- *Blackmon, G. H., Experiment Station, University of Florida, Gainesville (Horticulture)
- Blair, W. Frank, Laboratory of Vertebrate Genetics, University of Michigan, Ann Arbor, Michigan (Biology)
- Blaser, R. E., Experiment Station, University of Florida, Gainesville (Botany)
- *Bless, Arthur A., University of Florida, Gainesville (Physics)
- *Bly, R. S., Florida Southern College, Lakeland (Chemistry)
- Boles, Leo L., Groveland High School, Groveland
- *Boliek, M. Irene, Florida State College for Women, Tallahassee (Zoology)
- *Boyd, M. F., P. O. Box 793, Tallahassee (Epidemiology)
- *Browne, C. A., 3408 Lowell Street, N. W., Washington, D. C., (Chemistry, Agriculture)
- *Bruce, Malcolm, 325 Arlington Street, Gainesville (General)
- *Bryan, O. C., Box 209, Bartow (Agronomy)
- *Buckland, Charlotte B., Landon High School, Jacksonville (Biology)
- *Buswell, Walter M., University of Miami, Coral Gables (Botany)
- *Byers, C. F., University of Florida, Gainesville (Biology)
- *Camp, J. P., Experiment Station, University of Florida, Gainesville (Agronomy)
- Campbell, Robert B., 603 Wallace S. Building, Tampa, Fla. (Geology, Paleontology)
- †Carlin, Kathryn L., 248 Rivo Alto Island, Miami Beach (Chemistry)
- *Carr, A. F., Jr., University of Florida, Gainesville (Biology)
- Carr, Mrs. A. F., Jr., 440 Colson St., Gainesville (Biology)
- *Carr, T. D., 1828 W. Church Street, Gainesville (Physics)
- *Carver, W. A., Experiment Station, University of Florida, Gainesville (Agronomy)
- *Cason, T. Z., 2033 Riverside Avenue, Jacksonville (Medicine)
- *Chandler, H. W., University of Florida, Gainesville (Mathematics)
- *Christensen, B. V., University of Florida, Gainesville (Pharmacy)
- Clawson, Mrs. E. Richey, Ponce de Leon High School, Coral Gables (Chemistry, Physics)
- *Clouse, J. H., University of Miami, Coral Gables (Physics)

*Charter Member.

†Associate Member.

‡Individual Sustaining Member.

- *Conn, John F., Stetson University, DeLand (Chemistry)
- *Connor, Ruth, Florida State College for Women, Tallahassee (Home Economics)
- *Conradi, Edward, Florida State College for Women, Tallahassee (Psychology)
- Cooper, William C., United States Department of Agriculture, Orlando (Plant Physiology)
- *Dauer, Manning J., University of Florida, Gainesville (History, Political Science)
- †Davis, Barbara J., Apopka (Mathematics, Physics)
- *Davis, E. M., Rollins College, Winter Park (Ornithology, Entomology)
- †Davis, Katherine, P. O. Box 402, Homestead (Psychology, Botany)
- Davis, Norman W., Red Hill Road, Rockland County, New City, York York (Biology)
- *Davis, U. P., University of Florida, Gainesville (Mathematics)
- Dell, Mrs. R. G., 1006 Kennedy Avenue, Duquesne, Pa. (Zoology)
- *DeMelt, W. E., Florida Southern College, Lakeland (Psychology)
- *Deviney, Ezda, Florida State College for Women, Tallahassee (Zoology)
- Diddell, Mrs. W. D., 333 East 7th Street, Jacksonville (Botany)
- *Disher, Dorothy R., Florida State College for Women, Tallahassee (Psychology)
- *Dostal, B. F., University of Florida, Gainesville (Mathematics)
- *Doyle, S. R., Florida State College for Women, Tallahassee (Biology)
- *Dyrenforth, L. Y., 1022 Park Street, Jacksonville (Pathology)
- Eddins, A. H., Agricultural Experiment Station Laboratory, Hastings (Plant Pathology)
- Elder, J. H., Yale Laboratories of Primate Biology, Orange Park (Psychology)
- *Erck, G. H., Weirsdale (Agriculture)
- Eyman, Ralph L., Florida State College for Women, Tallahassee (Education)
- *Fairchild, David, 4013 Douglas Road, Coconut Grove (Botany)
- *Fargo, W. G., *December through April*: P. O. Box 874, Pass-a-Grille Beach; *May through December*: 506 Union St., Jackson, Mich.
- *Faulkner, Donald, Stetson University, DeLand (Mathematics)
- *Faust, Burton, 436 N. E. 94th Street, Miami (Physics and Mathematics)
- *Fernald, H. T., 1128 Oxford Road, Winter Park (Entomology)
- *Fifield, W. M., Experiment Station, University of Florida, Gainesville (Horticulture)
- *Finner, Paul F., Florida State College for Women, Tallahassee (Psychology)
- *Floyd, B. F., Davenport (Horticulture)
- *Floyd, W. L., University of Florida, Gainesville (Agriculture)
- *Foote, P. A., University of Florida, Gainesville (Pharmacy)
- *French, R. B., Experiment Station, University of Florida, Gainesville (Chemistry)
- *Gaddum, L. W., Experiment Station, University of Florida, Gainesville (Biochemistry)
- *Gautier, T. N., University of Florida, Gainesville (Physics)
- *George, C. R., Jr., 1514 Barnett National Bank, Jacksonville (Archeology)
- Gentry, Vernon S., Florida Southern College, Lakeland (Zoology)
- *Germond, H. H., University of Florida, Gainesville (Mathematics)
- *Gifford, J. C., University of Miami, Coral Gables (Forestry)

*Charter Member.

†Associate Member.

- *Giovannoli, Leonard, Key West Aquarium, Key West (Ichthyology)
 *Gist, N. N., Box 7, McIntosh (Agriculture)
 *Goff, C. C., Leesburg Experiment Station Laboratory, Leesburg (Plant Pathology)
 *Goin, Coleman, University of Florida, Gainesville (Biology)
 *Graham, Viola, Florida State College for Women, Tallahassee (Physiology)
 *Greene, E. Peck, P. O. Box 42, Tallahassee (Chemistry)
 Grimmer, J. Lear, Englewood (Zoology)
 *Gunter, Herman, State Geologist, Tallahassee (Geology)
 *Gut, H. James, P. O. Box 700, Sanford (Paleontology)
 *Hadley, A. H., 136 Arlington Way, Ormond Beach (Ornithology)
 *Harrison, R. W., 2337 N. W. Flagler Terrace, Miami
 *Hawkins, J. E., University of Florida, Gainesville (Chemistry)
 †Hayward, Wyndham, Winter Park (Horticulture)
 *Heinlein, C. P. Florida State College for Women, Tallahassee (Psychology)
 *Heinlein, Julia H., Florida State College for Women, Tallahassee (Psychology)
 *Hinckley, E. D., University of Florida, Gainesville (Psychology)
 Hjort, E. V., University of Miami, Coral Gables (Chemistry)
 *Hobbs, H. H., University of Florida, Gainesville (Biology)
 *Hodsdon, L. A., N. W. N. River Drive, Miami
 *Hubbell, T. H., University of Florida, Gainesville (Biology)
 Hughes, Ray C., University of Florida, Gainesville (Chemistry, Physics)
 *Hull, Fred H., Experiment Station, University of Florida, Gainesville (Genetics)
 *Hume, H. H., Experiment Station, University of Florida, Gainesville (Botany)
 *Johnson, R. S., University of Florida (General)
 *Kallman, I. E., P. O. Box 2747, Gainesville (General)
 Kantor, David, Chez Mme. Zubrowitz, Rue de Leescoy, 71, Anvers, Belgium (Bacteriology)
 *Keenan, Edward T., Frostproof (Soil Chemistry)
 *Kelly, Howard A., 1406 Eutaw Place, Baltimore, Maryland (Medicine)
 *Kime, C. D., Box 222, Orlando (Agriculture)
 *Kincaid, R. R., North Florida Experiment Station, Quincy (Plant Pathology)
 *Kinser, B. M., Eustis (General)
 *Kirk, W. G., Experiment Station, University of Florida, Gainesville (Animal Husbandry and Chemistry)
 Kirkland, Charles, Bonifay (Photography)
 *Knowles, H. L., University of Florida, Gainesville (Physics)
 Komarek, E. V., Thomasville, Georgia (Animal Ecology)
 Kramer, C. W., 2328 S. W. 17th Street, Miami (Plant Physiology)
 *Kurz, Herman, Florida State College for Women, Tallahassee (Botany)
 *Kusner, J. H., University of Florida, Gainesville (Mathematics, Astronomy)
 *Larson, Olga, Florida State College for Women, Tallahassee (Mathematics)
 *Leigh, Townes R., University of Florida, Gainesville (Chemistry)
 †Long, Mrs. Winifred O., 2030 43rd St., St. Petersburg (Botany, Zoology, Geology, Ornithology)
 *Longstreet, Rupert J., 610 Braddock Avenue, Daytona Beach (Psychology, Ornithology)

*Charter Member.

†Associate Member.

- Lord, E. L., Box 1948, Orlando.
- *Loucks, K. W., Experiment Station, Leesburg (Plant Pathology)
Lynch, S. J., Homestead (Sub-tropical Horticulture)
- *Lynn, Elizabeth, Florida State College for Women, Tallahassee (Physics)
McAllister, Birdie, Miami Beach High School, Miami Beach (Taxonomy, Ecology)
- *McClanahan, R. C., U. S. Biological Survey, Washington, D. C. (Biology)
- *MacGowan, W. Leroy, 3212 Park Street, Jacksonville (Biology)
- *McKinnell, Isabel, Florida State College for Women, Tallahassee (Chemistry)
- *Maborner, Sue A., 1663 Margaret St., Jacksonville (Psychology)
- *Marshall, J. J., 918 Seybold Building, Miami (Astronomy)
- *Mathews, E. L., Plymouth (Horticulture)
Mendenhall, H. D., Florida State College for Women, Tallahassee (Engineering)
- *Meyer, Max F., University of Miami, Coral Gables (Psychology)
- †Miller, Dorothy B., University of Miami, Coral Gables (Zoology)
- *Miller, E. Morton, University of Miami, Coral Gables (Zoology)
- Montgomery, J. H., State Plant Board, Gainesville (Entomology)
- *Moore, Coyle E., Florida State College for Women, Tallahassee (Sociology)
- *Moore, F. Clifton, Florida State College for Women, Tallahassee (Medicine)
- *Mosier, Charles I., University of Florida, Gainesville (Psychology)
- *Mowry, Harold, Experiment Station, University of Florida, Gainesville (Horticulture)
- Mulvania, Maurice, Florida Southern College, Lakeland (Botany)
Murray, Mary R., Robert E. Lee Junior High School, Miami (General)
- *Neal, W. M., Experiment Station, University of Florida, Gainesville (Animal Husbandry)
Newell, Wilmon, University of Florida, Gainesville (Agriculture)
- *Newins, H. S., University of Florida, Gainesville (Forestry)
- Ogden, J. G., Florida Southern College, Lakeland (Physical Geography)
- †Ogilvie, Frances May, Stetson University, DeLand
- *Osborn, Herbert, Rollins College, Winter Park (Zoology, Entomology)
Owen, B. Jay, Box 1111, Tallahassee (Chemistry)
- Packham, Audrey, 1230 Richmond Road, Winter Park (Psychology)
- Palmer, Katharine B., 135 N. W. 60th Street, Miami (Biology)
- *Parker, Horatio Newton, 2777 Park Street, Jacksonville (Public Health)
- *Partridge, Sarah W., 508 S. Duval Street, Tallahassee (Biology)
- *Pearson, Hazel M., University of Miami, Coral Gables (Ecology)
- *Pearson, J. F. W., University of Miami, Coral Gables (Zoology)
Penningroth, Paul W., St. Petersburg Junior College, St. Petersburg (Psychology)
- Perry, Louise M., Sanibel (Marine Biology, Ornithology)
- *Perry, W. S., University of Florida, Gainesville (Physics)
- *Phillips, Walter S., University of Miami, Coral Gables (Botany)
- *Phipps, Cecil G., University of Florida, Gainesville (Mathematics)
- *Ponton, G. M., Florida State Road Department, Tallahassee (Geology)
Quade, E. S., University of Florida, Gainesville (Mathematics)
- *Raa, Ida, Leon High School, Tallahassee (Chemistry)
- *Reinsch, B. P., Florida Southern College, Lakeland (Mathematics, Physics)

*Charter Member.

†Associate Member.

- *Richards, Harold F., Florida State College for Women, Tallahassee
(Physics)
- *Robinson, T. Ralph, P. O. Box 1058, Orlando
- *Rogers, J. Speed, University of Florida, Gainesville (Biology)
- *Rogers, L. H., Experiment Station, University of Florida, Gainesville
(Chemistry)
- *Rolfs, C., 509 E. Church Street, Gainesville (Botany)
- *Rolfs, P. H., 509 E. Church Street, Gainesville (Botany)
- *Ruehle, George D., Experiment Station, Homestead (Plant Pathology)
- *Rusoff, L. L., University of Florida, Gainesville (Biochemistry)
- *Sadler, G. G., 315 N. Highland Street, Mount Dora (Zoology)
- *Sandels, Margaret R., Florida State College for Women, Tallahassee
(Home Economics)
- Scarborough, Mrs. Christine, Florida State College for Women, Tallahassee
(Psychology)
- Schell, Hannah, 220 2nd Street, N. E., Winter Haven (Biology, Chemistry)
- Schofield, W. L., Lakeview High School, Winter Garden (Biology)
- *Schornherst, Ruth, Florida State College for Women, Tallahassee (Botany)
- *Scott, George G., 1394 Grove Terrace, Winter Park (Biology)
- *Senn, P. H., University of Florida, Gainesville (Agronomy)
- *Shealy, A. L., University of Florida, Gainesville (Animal Husbandry)
- *Sherman, H. B., University of Florida, Gainesville (Biology)
- *Shippy, W. B., Experiment Station, Sanford (Plant Pathology)
- *Shor, Bernice C., Rollins College, Winter Park (Biology)
- Shudeman, C. L. B., Florida Southern College, Lakeland (Physics)
- *Sieplein, O. J., P. O. Box 212, Coral Gables (Chemistry)
- *Smith, Cornelia M., Stetson University, DeLand (Biology)
- *Smith, Frank, 875 Marine Court South, St. Petersburg (Zoology)
- Smith, Frederick B., University of Florida, Gainesville (Microbiology)
- Smith, H. F., Andrew Jackson High School, Jacksonville (Physics,
Chemistry, Biology)
- Smith, Maxwell, Lantana (Biology)
- *Smith, Richard M., P. O. Box 212, Tallahassee (Chemistry)
- *Springer, Stewart, Bass Biological Laboratory, Englewood (Zoology)
- *Spurr, J. E., Rollins College, Winter Park (Geology)
- *St. John, Robert P., Floral City (Botany)
- *Stevens, H. E., 224 Annie Street, Orlando (Horticulture)
- *Stewart, Alban, Florida State College for Women, Tallahassee (Botany,
Bacteriology)
- *Stiles, C. Wardell, Smithsonian Institution, Washington, D. C. (Zoology)
- *Stokes, W. E., Experiment Station, University of Florida, Gainesville
(Agronomy)
- *Story, Helen F., 2762 Burlington Avenue, St. Petersburg (Astronomy,
Mathematics)
- *Stubbs, Sidney A., State Museum, University of Florida, Gainesville
(Geology)
- *Swanson, D. C., University of Florida, Gainesville (Physics)
- Tallant, W. M., Bradenton (Archeology)
- *Tanner, W. Lee, 732 N. W. 36th Street, Miami (Chemistry)
- *Thomas, R. H., 37 S. Hogan Street, Jacksonville (Electricity)
- *Tilt, Jennie, Florida State College for Women, Tallahassee (Chemistry)
- *Tisdale, W. B., Experiment Station, University of Florida, Gainesville
(Plant Pathology)

*Charter Member.

†Associate Member.

- *Tissot, A. N., Experiment Station, University of Florida, Gainesville (Entomology)
- *Tracy, Anna M., Florida State College for Women, Tallahassee (Nutrition)
- *Van Cleef, Alice, Glenwood (Chemistry and Biology)
- Van Dusen, A. C., University of Florida, Gainesville (Psychology)
- *Van Leer, B. R., North Carolina State College, Raleigh, N. C. (Engineering)
- *Vance, Charles B., Stetson University, DeLand (Geology)
- *Vermillion, Gertrude, Florida State College for Women, Tallahassee (Chemistry)
- *Waddington, Guy, Rollins College, Winter Park (Chemistry)
- *Wallace, Howard K., University of Florida, Gainesville (Biology)
- *Waskom, Hugh L., Florida State College for Women, Tallahassee (Psychology)
- Watson, J. R., Experiment Station, University of Florida, Gainesville (Entomology)
- *Weber, George F., Experiment Station, University of Florida, Gainesville (Plant Pathology)
- *Weil, Joseph, University of Florida, Gainesville, (Engineering)
- *Weinberg, E. F., Rollins College, Winter Park (Mathematics)
- *West, Erdman, University of Florida, Gainesville (Botany)
- *West, Frances L., St. Petersburg Junior College, St. Petersburg (Biology)
- †West, Henry S., University of Miami, Coral Gables (Psychology)
- *White, Sarah P., Florida State College for Women, Tallahassee (Medicine)
- *Williams, F. Dudley, University of Florida, Gainesville (Physics)
- *Williams, Henry W., Drawer C, Umatilla (Herpetology)
- *Williams, Osborne, University of Florida, Gainesville (Psychology)
- Williamson, B. F., 129 E. Main St. N., Gainesville (Tung Production and Manufacturing)
- *Williamson, R. C., University of Florida, Gainesville (Physics)
- *Willoughby, C. H., University of Florida, Gainesville (Animal Husbandry)
- Wimberly, Stan E., University of Florida, Gainesville (Psychology)
- *Wise, Louis E., Rollins College, Winter Park (Chemistry)
- Witmer, Louise R., Florida State College for Women, Tallahassee (Psychology)
- Worchel, Phillip, Florida State Hospital, Chattahoochee (Psychology)
- *Wray, F. L., 1927 Hollywood Blvd., Hollywood
- Yothers, W. W., 457 Boone Street, Orlando
- *Young, John W., 720 Glen Ridge Drive, West Palm Beach (Mathematics, Physics)

INSTITUTIONAL SUSTAINING MEMBERS

Florida Southern College, Lakeland
 Florida State College for Women, Tallahassee
 Rollins College, Winter Park
 Stetson University, DeLand
 University of Florida, Gainesville
 University of Miami, Coral Gables

*Charter Member.

†Associate Member.



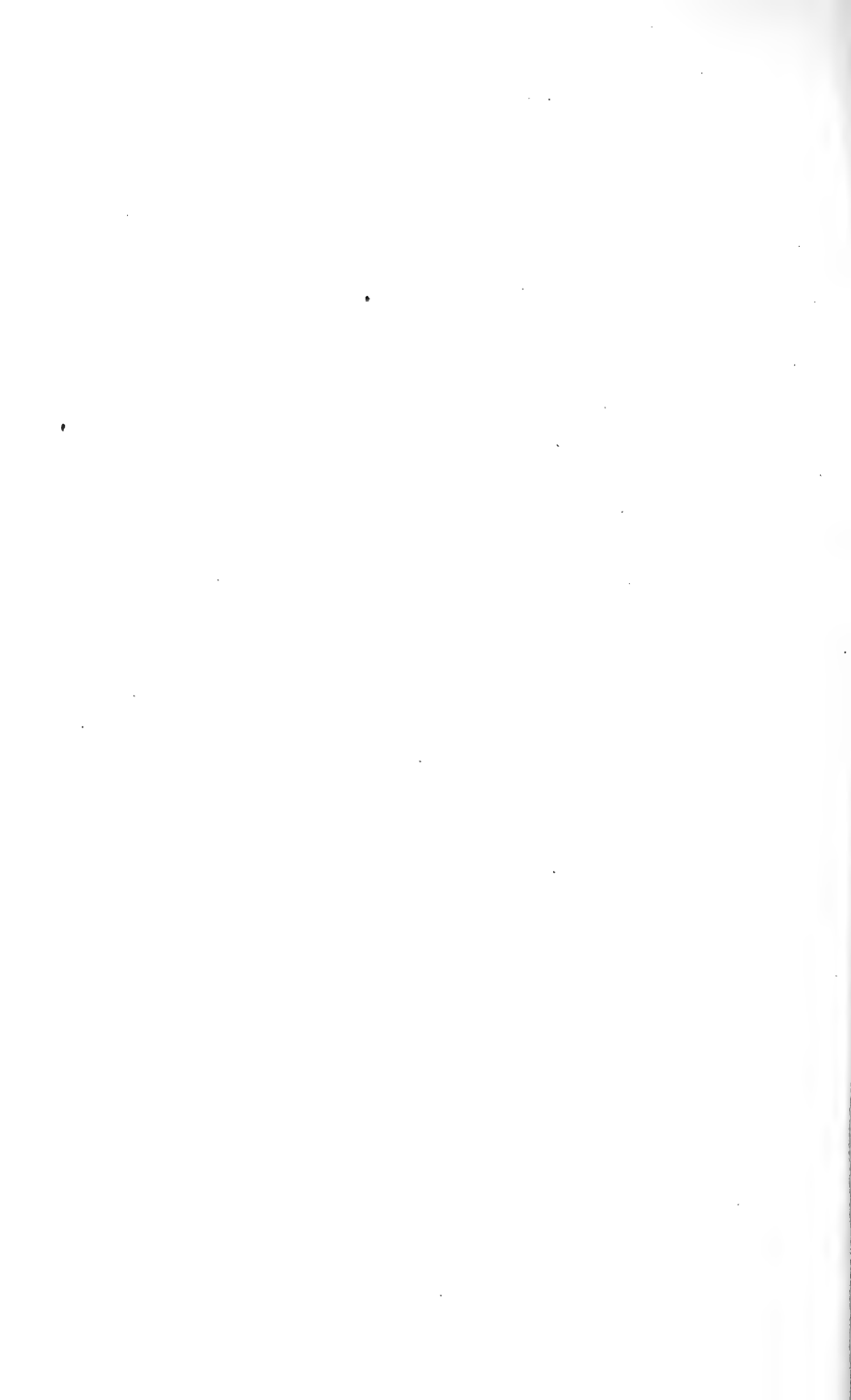

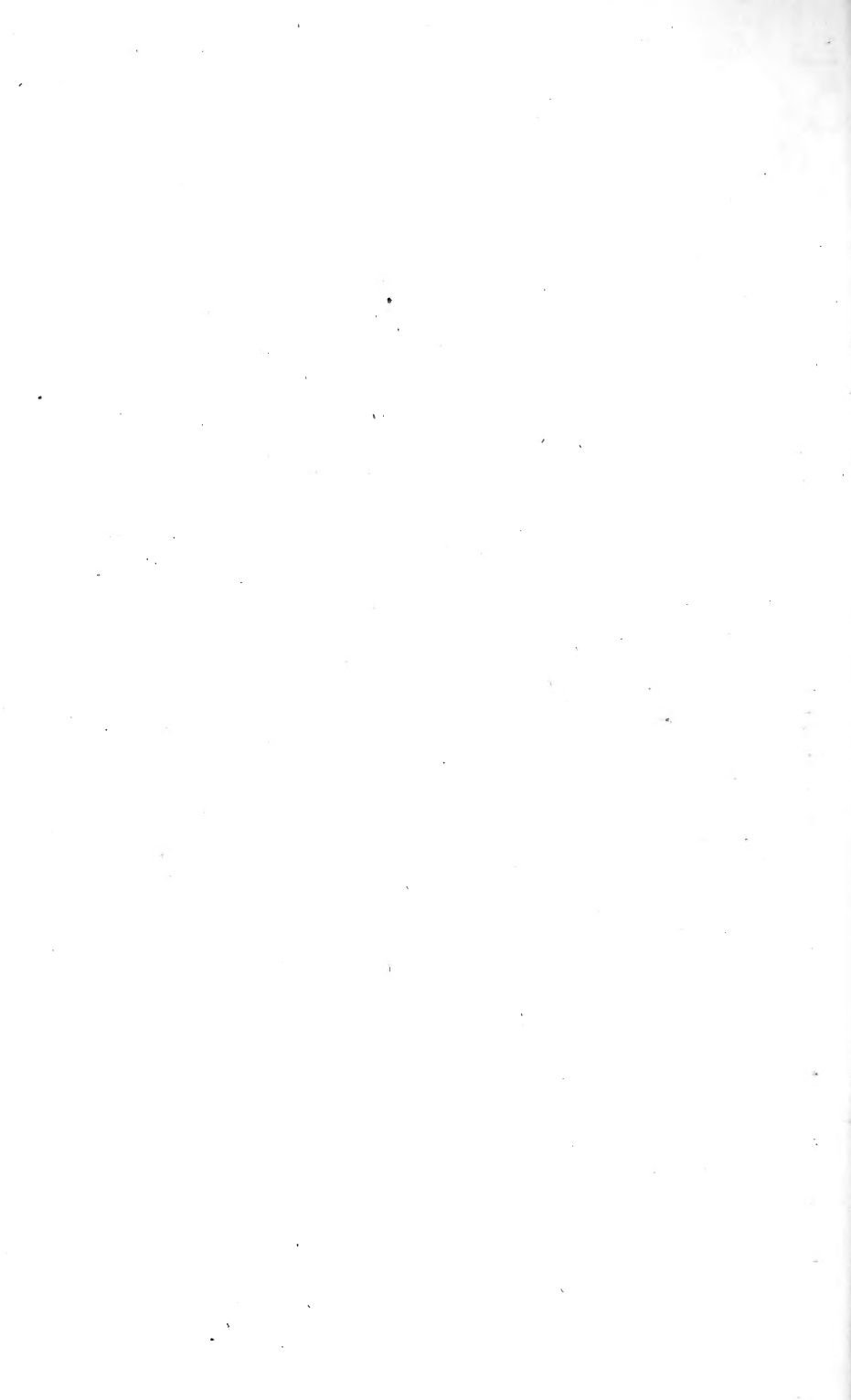

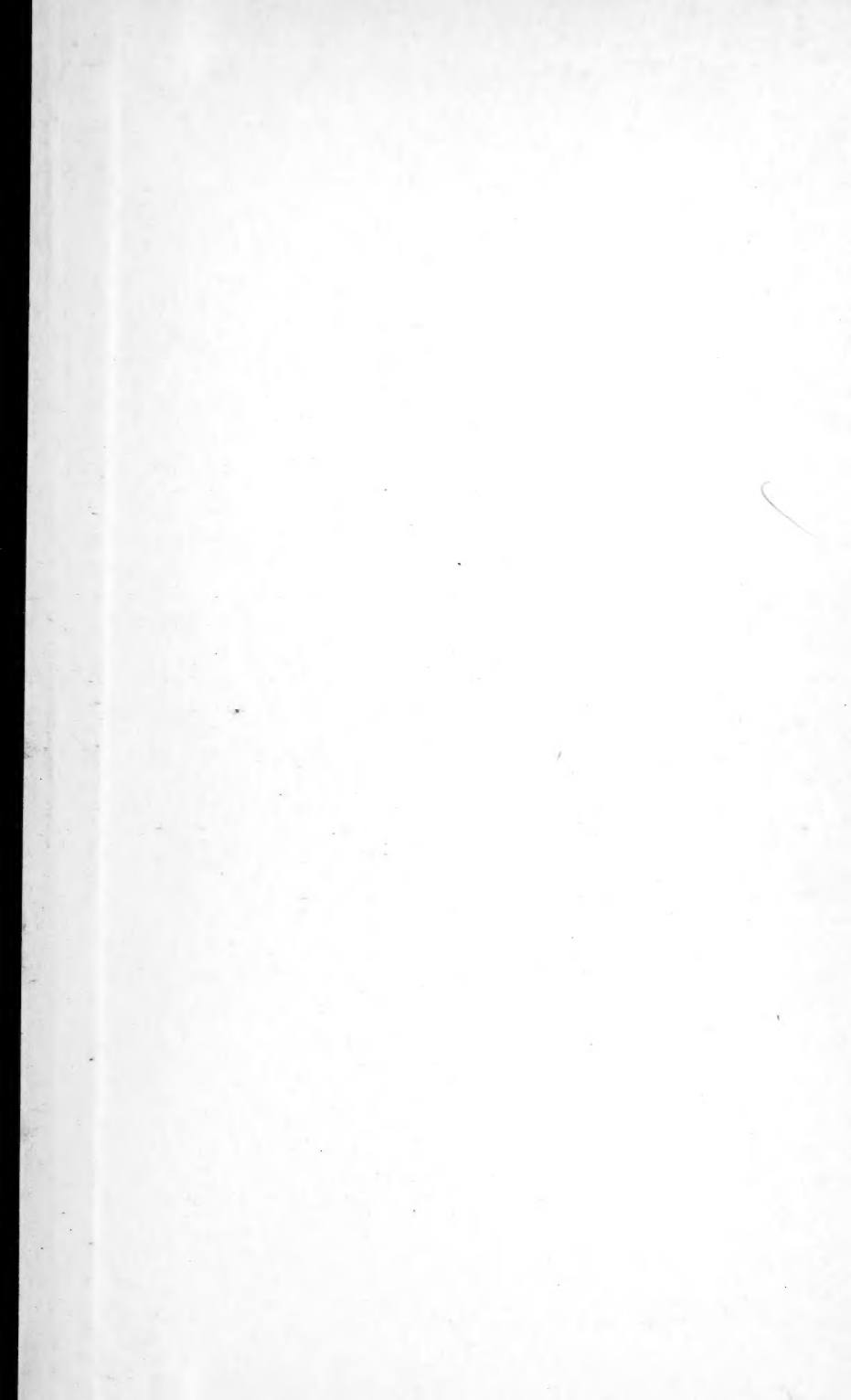

SMITHSONIAN INSTITUTION LIBRARIES



3 9088 01354 1545

