

Library of the Museum
OF
COMPARATIVE ZOÖLOGY,
AT HARVARD COLLEGE, CAMBRIDGE, MASS.

The gift of

No. 248

Jan. 20, 1893 - Jan. 29, 1894.

PROCEEDINGS

OF THE

AMERICAN PHILOSOPHICAL SOCIETY

HELD AT PHILADELPHIA

FOR

PROMOTING USEFUL KNOWLEDGE.

Vol. XXXI.

JANUARY TO DECEMBER, 1893.

PHILADELPHIA:
PRINTED FOR THE SOCIETY
BY MAC CALLA & COMPANY,
1893.

PROCEEDINGS

OF THE

AMERICAN PHILOSOPHICAL SOCIETY,

HELD AT PHILADELPHIA, FOR PROMOTING USEFUL KNOWLEDGE.

VOL. XXXI.

JANUARY, 1893.

No. 140.

January 6, 1893.

The annual meeting for election of Officers and Councilors was held this afternoon between the hours of 2 and 5 o'clock, after due public notice. The result of the ballot was reported by the Judges and the Clerks to the Society at its evening meeting.

Stated Meeting, January 6, 1893.

Mr. THOMAS H. DUDLEY in the Chair.

Mr. Harold Goodwin, a newly elected member, was presented to the Chair and took his seat.

Dr. Elliott Coues requested by letter a further extension for three months of the time during which he could retain the Lewis and Clark MSS. Upon motion, the request was granted.

Acceptances of membership were read from Dr. Samuel G. Dixon, Philadelphia; Dr. James Macfarlane, Lansdowne, Pa., and Dr. James Ellis Humphrey, Amherst, Mass.

An invitation from the Wadsworth Athenæum, at Hartford, to be present at the opening of the new Libraries and Art Galleries, was read.

The Enoch Pratt Free Library of Baltimore requested to be placed on the Proceedings' exchange list. On motion, the application was granted.

The Academy of Natural Sciences acknowledged the receipt of the Secretary's letter of December 16, relating to the Keating-Poinsett Collection, stating that the same had been referred to the Curators.

A circular from the American Folk-Lore Society, announcing its annual meeting for 1892 at Boston.

Accessions to the Library were reported from the Royal Asiatic Society (Straits Branch), Singapore; Royal Society of Victoria, Melbourne; Department of Mines, Wellington, N. Z.; Anthropological Society, Tokyo, Japan; Statistiska Central Byråns, Stockholm, Sweden; Maatschappij der Nederlandsche Letterkunde, Leiden, Holland; Académie Royale de Belgique, Bruxelles; Académie des Sciences, Cracow, Austria; Anthropologische Gesellschaft, Vienna, Austria; Naturforschende Gesellschaft, Altenburg, Germany; Physiologische Gesellschaft, Gesellschaft für Anthropologie, etc., Gesellschaft für Erdkunde, Berlin; Gartenbauverein, Darmstadt; K. Oeffentliche Bibliothek, Dresden; Verein für Erdkunde, Halle a. S.; Deutsche Seewarte, Hamburg; Geographische Gesellschaft, Munich, Bavaria; Naturwissenschaftlicher Verein, Regensburg; Biblioteca N. C. Firenze, Italia; R. Accademia dei Lincei, Rome; Société de Géographie, Lille, France; Commission des Annales des Mines, Société de L'Enseignement, Société de Géographie, Rédaction *Cosmos*, Paris; R. Academia de la Historia, Madrid, Spain; South African Philosophical Society, Cape Town; R. Astronomical Society, R. Geographical Society, Editors of *Nature*, London; University Observatory, Glasgow; Royal Society, Edinburgh; Mr. Horatio Hale, Clinton, Ontario; Canadian Institute, Toronto; Boston Athenæum, Society of Natural History, Boston, Mass.; Harvard University, Cambridge, Mass.; Travelers' Insurance Co., Hartford, Conn.; Editors of *American Journal of Science*, New Haven; Brooklyn Library; Cornell University, Ithaca, N. Y.; American Institute of Electrical Engineers, Mathematical So-

ciety, Meteorological Observatory, Dr. Joel Asaph Allen, New York; Mr. William John Potts, Camden; Free Public Library, Jersey City; College of Pharmacy, Editors of the *Medical News*, Editors of the *Medical and Surgical Reporter*, Hon. Frederick Fraley, Dr. Walter M. James, Dr. D. Jayne and Son, Messrs. Abraham Jordan, J. G. Rosengarten, David Henry Wright, Philadelphia; Editor of the *American Chemical Journal*, Baltimore; Commissioner of Pensions, U. S. Department of Agriculture, Census Office, Hydrographic Office, Washington, D. C.; University of California, Berkeley; Agricultural Experiment Station, Lincoln, Neb.; Instituto Fisico-Geografica, San José, C. A.; Société Scientifique du Chile, Santiago, S. A.

The following deaths were reported :

Sir Richard Owen, December 18, 1892, æt. 89.

John O. Westwood, January 2, 1893, æt. 88.

Eben N. Horsford, January 1, 1893, æt. 75.

Isaac C. Martindale, January 3, 1893, æt. 50.

The President was authorized to appoint a suitable person to prepare the usual obituary notice of Mr. Martindale.*

The report of the Clerks and Judges of the election held this afternoon at the hall of the Society was read, and the following members declared to have been duly chosen Officers and Councilors for the ensuing year, 1893 :

President.

Frederick Fraley.

Vice-Presidents.

E. Otis Kendall, W. S. W. Ruschenberger, J. P. Lesley.

* Dr. Joseph T. Rothrock was subsequently appointed.

Secretaries.

George F. Barker, Daniel G. Brinton, Henry Phillips, Jr.,
George H. Horn.

Curators.

Patterson Du Bois, J. Cheston Morris, R. Meade Bache.

Treasurer.

J. Sergeant Price.

Councilors.

William A. Ingham, Thomas H. Dudley, Robert Patterson,
Charles S. Wurts.

(Councilor for two years, in place of I. C. Martindale, deceased.)

Henry C. Baird.

This being the evening for the nomination of a member to serve as Librarian of the Society during the ensuing year, Mr. Henry Phillips, Jr., was renominated, and the nominations were closed.

Mr. Goodwin exhibited a portrait of the late John Vaughan Eyre.

Pending nominations Nos. 1235, 1249, 1250 and 1251 were read.

And the Society was adjourned by the Presiding Member.

Stated Meeting, January 20, 1893.

MR. RICHARD VAUX in the Chair.

Dr. Francis X. Dercum, a lately elected member, was presented to the Chair and took his seat.

Correspondence was submitted as follows :

A circular from the Royal Academy of Sciences of Turin, Italy, announcing its offer of the Ninth Bressa Prize, to be given to the author or inventor who shall have made the most important and useful discovery, or published the most valuable work, on Science, Natural History, Chemistry, etc., etc., during the years 1891-94.

A letter from the New York State Library, Albany, asking the Society to exhibit a complete set of its publications at the Columbian Celebration, the same to become the property of the State Library when the celebration is over.

The following letter from the Academy of Natural Sciences of Philadelphia, in relation to the Keating-Poinsett collection of Aztec handworks deposited by the American Philosophical Society, which, on motion, was referred to the Curators.

PHILADELPHIA, January 19, 1893.

MR. HENRY PHILLIPS, JR.,

Secretary of the American Philosophical Society :

Dear Sir:—I have the honor to inform you that your communication of the 16th ult., regarding the custody of the Keating-Poinsett collection of Aztec objects, having been referred for consideration to the Curators of the Academy, the following report was received by the Academy at the meeting of the 17th inst., and a copy was ordered to be sent to you in reply to your letter of inquiry :

“The Curators, to whom has been referred a communication from the American Philosophical Society, dated December 16, 1892, and addressed to the President and members of the Academy, in reference to the retention of the Poinsett Collection of Aztec handworks deposited in the Academy several years ago, respectfully report :

“Although all the specimens of the Poinsett Collection are artificial, and therefore not absolutely within the scope of the Academy's chief purpose, which is the study of natural objects, it is considered desirable that

the Academy shall still retain said collection as a loan on the conditions stipulated at the time of its deposit.

“The American Philosophical Society may be assured that the Poinsett Collection, while in custody of the Academy, will be carefully preserved; and that as soon as the perfectly fireproof addition to the Academy’s building now in course of construction, under contract to be completed next June, is finished, there will be ample room for a satisfactory display of it as well as of similar collections. As the Museum of the Academy is freely open to the public from eight to ten hours every day, except Sunday, throughout the year, it is confidently conjectured that the Poinsett Collection will be visited and studied here by a greater number of persons than it would be in any other place of exhibition in the city.

“It is neither necessary nor expedient that the Academy should propose any condition whatever in connection with the retention of the Poinsett Collection as a loan from the American Philosophical Society.”

The report is signed and submitted on behalf of the Curators by Dr. W. S. W. Ruschenberger, the Chairman of the Board.

I remain, yours very truly,

EDWARD J. NOLAN,

Recording Secretary, A. N. S., Philadelphia.

A letter from Dr. Elliott Coues, Washington, D. C., thanking the Society for its grant of extension of time in the Lewis and Clark MSS. loan; also, offering a paper for publication in the Proceedings, descriptive of the Lewis and Clark MSS.

Letters of envoy were received from the Maatschappij der Nederlandsche Letterkunde, Leiden; Instituto Físico Geográfico Nacional de Costa Rica, San José; Mr. William John Potts, Camden, N. J.

Letters of acknowledgment were received from the Royal Geographical Society of Australasia (Queensland Branch), Brisbane (138); Linnean Society of New South Wales (135–138), Royal Society of New South Wales (136, 137), Sydney; Maatschappij der Nederlandsche Letterkunde, Leiden (137, 138); I. R. Accademia degli Agiati, Rovereto, Tyrol (138); K. K. Militär-Geographische Institut, Vienna, Austria (137, 138); Naturforschende Gesellschaft, Emden (138); Naturwissenschaftlicher Verein des Regierungs-Bezirks Frankfurt, a. O. (135); Geographische Gesellschaft (137), Naturhistorische Gesellschaft (138), Hanover, Prussia; Naturwissenschaftlicher Verein, Regensburg, Bavaria (137); R. Accademia di Scienze,

Lettrè ed Arti, Modena, Italy (138); Osservatorio Astronomico, Turin (138); Prof. Gaston Maspero, Paris (138); Zoölogical Society, London (137, 138, and Trans., xvii, 1, 2); Public Library of Boston (132-138); State Library of Pennsylvania, Harrisburg (Trans, xvii, 1, 2); Denison Scientific Association, Granville, O. (138).

Accessions to the Library were reported from the Geographical Society, Tokyo, Japan; Société Finno-Ougrienne, Helsingfors, Finland; Mining Department of South Australia, Adelaide, Australia; Ministerie van Binnenlandsche Lachen, 'S Gravenhage, Z. Holland; Société R. de Geographie D'Anvers, Bruxelles; Naturwissenschaftlicher Verein des Reg.-Bez. Frankfurt a. O., Prussia; Société Vaudoise Sciences Naturelles. Lausanne, Switzerland; Editor of "La Revue des Revues," Prof. E. Levasseur, Paris, France; R. Academia de Ciencias y Artes, Barcelona, Spain; Philological Society, Society of Arts, Royal Meteorological Society, Editor of the "Geological Magazine," London, England; Geological Society, Manchester, England; American Academy of Arts and Sciences, Boston, Mass.; Harvard University, Museum of Comparative Zoölogy, Cambridge, Mass.; Yale University, New Haven, Conn.; New York State Library, Albany; Dr. Joel Asaph Allen, New York, N. Y.; Academy of Science, Mr. George F. Becker, Rochester, N. Y.; Franklin Institutè, College of Pharmacy, Mr. Henry Carey Baird, Philadelphia, Pa.; Prof. J. T. Rothrock, West Chester, Pa.; Maryland Academy of Sciences, Johns Hopkins University, Baltimore, Md.; Anthropological Society, Bureau of the Mint, Bureau of Statistics, Washington, D. C.; Elisha Mitchell Scientific Society, Chapel Hill, N. C.; Denison University, Editors of the "Journal of Neurology," Granville, O.; State Board of Health, Nashville, Tenn.; Agricultural Experiment Stations, Hanover, N. H., New Haven, Conn., Experiment, Ga., Baton Rouge, La., Bryan, Tex.; Agricultural College, Mich.; Madison, Wis.; St. Anthony Park, Minn.; Corvallis, Ore.; Fargo, N. Dak.; Observatorio de Rio de Janeiro.

The Committee on the Michaux Legacy presented the

following report and resolutions, which were unanimously adopted by the Society :

TO THE AMERICAN PHILOSOPHICAL SOCIETY :

The Michaux Committee respectfully reports :

That at a meeting of the Committee held on December 29, 1892, the following letter was received from Prof. J. T. Rothrock :

“ December 16, 1892.

“ TO THE AMERICAN PHILOSOPHICAL SOCIETY :

“ I most respectfully request that the American Philosophical Society will appropriate from the income of the Michaux Fund the sum of three hundred dollars (if said fund will so admit), to aid in defraying the expenses of collecting facts and statistics bearing upon the relation of our forests to the Commonwealth, promising to furnish a report to the Society by February, 1894.

“ Notwithstanding the general interest in the subject of Forestry, there is an utter absence of the data required for any proper presentation of the important questions involved.

“ It is thought that no use more immediately helpful and more in accord with the wishes of the testator could be made of the money.

“ Very respectfully,

“ J. T. ROTHROCK.”

The Committee, having carefully considered the subject, approves of the suggestion of Prof. Rothrock, and submits the following resolution, which it desires shall be passed by the Society :

Resolved, That the sum of three hundred dollars be appropriated out of the income of the Michaux Fund to Prof. J. T. Rothrock, to aid in defraying the expenses of collecting facts and statistics bearing upon the relation of our forests to the Commonwealth of Pennsylvania, which when obtained he shall report in full in writing to the Society.

By order of the Committee,

J. SERGEANT PRICE,

Secretary.

The President was authorized to appoint the Standing Committees of the Society for the ensuing year, which he subsequently did as follows :

Finance.

William B. Rogers, Philip C. Garrett, Charles S. Wurts.

Hall.

J. Sergeant Price, William A. Ingham, Charles A. Oliver.

Publication.

Daniel G. Brinton, George H. Horn, Samuel Wagner,
Patterson Du Bois, Horace Jayne.

Library.

Edwin J. Houston, William John Potts, Jesse Y. Burk,
William H. Greene, William S. Baker.

Michaux Legacy.

Thomas Meehan, J. Sergeant Price, William M. Tilghman,
Isaac Burk, Angelo Heilprin.

Henry M. Phillips' Prize Essay Fund.

Richard Vaux, Henry Phillips, Jr., William V. McKean,
Furman Sheppard, Joseph C. Fraley,
and

The President and the Treasurer of the Society, *ex officio*.

Mr. Henry Phillips, Jr., was unanimously reelected Librarian of the Society for the ensuing year.

Dr. Elliott Coues presented for the Proceedings, through the Secretaries, "A Description of the MSS. Journals and Field Notebooks of Lewis and Clark."

Pending nominations Nos. 1235, 1249, 1250, 1251, and new nominations Nos. 1252, 1253, 1254, were read.

And the Society was adjourned by the Presiding Member.

Stated Meeting, February 3, 1893.

Mr. VAUX in the Chair.

Dr. Macfarlane took his seat.

Correspondence was submitted as follows:

Letters of envoy were received from the Observatoire Physique Central, St. Petersburg, Russia; K. Akademie der Wis-

senschaften, Vienna, Austria; Royal Irish Academy, Dublin; Mr. Henry Carey Baird, Philadelphia, Pa.

Letters of acknowledgment were received from the Royal Geographical Society of Australasia (Victoria Branch), Melbourne (137); Royal Society of New South Wales, Sydney, Australia (138); Geological Survey of India, Calcutta (138); K. K. Sternwarte, Prag, Bohemia (Trans., xvii, 1, 2, and 138); K. K. Astronomisch-Meteorologisches Observatorium, Triest, Illyria (138); K. K. Naturhistorisches Hofmuseum, Vienna, Austria (138); Naturhistorischer Verein, Bonn, Prussia (137, 138); Physikalisch-Medicinische Societät, Erlangen, Bavaria (138); Naturwissenschaftlicher Verein des Reg.-Bez. Frankfurt a. M. (136, 138); Mr. Tommaso Cannizzaro, Messina, Italy (138); Académie R. des Sciences (Trans., xvii, 1, 2, and 138); Prof. Guido Cora, Turin, Italy (138); Dublin Observatory, Dublin, Ireland (137); Mass. State Experiment Station, Amherst (138); Prof. Andrew A. Blair (136-138); Dr. Isaac Norris, Philadelphia (137, 138); State Library, Albany, N. Y. (138); Denison Scientific Association, Granville, O. (138).

Letters of acknowledgment (139) were received from the Academy of Natural Sciences, Historical Society of Pennsylvania, College of Physicians, Library Company of Philadelphia, Numismatic and Antiquarian Society, Admiral E. Y. Macauley, Hon. James T. Mitchell, Profs. John Ashhurst, Jr., Andrew A. Blair, John H. Brinton, J. Solis Cohen, E. D. Cope, F. X. Dercum, F. A. Genth, Jr., H. D. Gregory, L. M. Haupt, Edwin J. Houston, John M. Maisch, John Marshall, Benjamin Sharp, Drs. George Friebis, Henry Hartshorne, Isaac Norris, Charles A. Oliver, C. N. Peirce, J. W. Robins, W. S. W. Ruschenberger, James Tyson, Messrs. R. Meade Bache, Henry Carey Baird, Charles Bullock, Thomas M. Cleemann, Patterson Du Bois, J. S. Harris, Francis Jordan, Jr., A. S. Letchworth, R. Patterson, Henry Phillips, Jr., Franklin Platt, J. Sergeant Price, Theodore D. Rand, J. G. Rosengarten, Coleman Sellers, D. K. Tuttle, Joseph Wharton, Philadelphia, Pa.

Accessions to the library were reported from the Sociétés des Naturalistes, Kiew, Moscow, Odessa, Russia; K. Akademie

der Wissenschaften, St. Petersburg, Russia; Kolonial Museum, Haarlem, Holland; K. K. Sternwarte, Prag, Bohemia; K. K. Geologische Reichsanstalt, Akademie der Wissenschaften, Vienna, Austria; Verein zur Beförderung des Gartenbaues, Berlin, Prussia; Naturhistorischer Verein, Bonn, Prussia; Oberlausitzische Gesellschaft der Wissenschaften, Görlitz, Prussia; K. Sächsische Gesellschaft der Wissenschaften, Leipzig, Saxony; Deutsche Gesellschaft für Anthropologie, etc., Munich, Bavaria; R. Osservatorio, Turin, Italy; Royal Society, London; Royal Society, Edinburgh; R. Irish Academy, Dublin; Harvard College Astronomical Observatory, Cambridge, Mass.; Yale University Astronomical Observatory, New Haven, Conn.; Mr. Henry Carey Baird, Philadelphia, Pa.; Agricultural Experiment Stations, Newark, Del., Raleigh, N. C., Agricultural College, Miss.; U. S. Naval Institute, Annapolis, Md.; U. S. Naval Observatory, Department of the Interior, Publishers of *The American Monthly*, Mr. Lester F. Ward, Washington, D. C.; Historical Society, Chicago, Ill.; State Historical Society, Iowa City, Ia.; Kansas State Historical Society, Topeka; Geological Survey of Missouri, Jefferson City, Mo.; Sociedad Científica "Antonio Alzate," Mexico, Mex.; Institute of Jamaica, Kingston, Jamaica; Sociedad Científica Argentina, Buenos Aires, Argentine Republic.

The death of Dr. F. A. Genth was reported (February 2, 1893, æt. 73,) and Dr. G. F. Barker was appointed to prepare the usual obituary notice.

The Secretaries presented a paper by Prof. A. S. Packard (Providence, R. I.) on "The Life History of the Cochliopodidæ."

Dr. Cope made a communication on "The Fauna of the Eurystylus and Equus Beds of the Staked Plains."

Pending nominations Nos. 1235, 1249, 1250, 1251, 1252, 1253, 1254 were read.

The Curators presented the following report relative to the requested loan of objects for the World's Fair Columbian Exposition :

CURATORS' REPORT UPON THE SOCIETY'S RESOLUTION OF
OCTOBER 7, 1892.

In the matter of the request for the loan of certain articles, belonging to the Society, for the Chicago Exposition, your Curators respectfully recommend the loan of said articles for said purpose, provided that the city authorities are willing to guarantee their safe transportation, custody and return, in accordance with such forms of agreement as may be approved by the President and Treasurer of the Society.

J. CHESTON MORRIS,
R. MEADE BACHE,
PATTERSON DU BOIS,
Chairman.

After considerable discussion the following motion made by Mr. Du Bois was adopted :

Resolved, That the Society, while being desirous of doing everything to gratify the wishes of the Committee of Councils on the World's Columbian Exposition, feels that it cannot allow the articles mentioned in the request of the Committee, to be taken away at this time, as it intends to have a sesqui-centennial exhibition in its own rooms during the latter part of May, 1893, and will need them here. It is compelled therefore to respectfully decline the proposition presented by your Committee.

The Curators presented the following report upon the collections of the Society :

CURATORS' REPORT.

In response to the Society's resolution of December 16, 1892, the Curators respectfully report :

1. That the cost of transferring the collections and arranging them in suitable cases would not exceed, even if it equaled, five hundred dollars.

2. There would be but slight cost of maintenance of the collections apart from any idea of a paid employé who would have personal daily oversight during the hours in which the collections should be open for exhibition and study.

3. In the nature of the case, it is impossible for the Curators to say what the cost of maintaining the collections in other institutions would be.

4. Although undoubtedly the collections of the Society could all be exhibited in the north room of the hall, yet your Curators would respectfully beg leave to say that the settlement of the original question as to whether or not one or more, and which, if any, of them is to be exhibited in the building, is an indispensable preliminary to the determination of some plan for the arrangement of these collections as required by the resolution of the Society.

J. CHESTON MORRIS,
R. MEADE BACHE,
PATTERSON DU BOIS,
Chairman.

Dr. D. G. Brinton moved "that the Society would prefer to have all its collections displayed by such other educational institutions of Philadelphia as would offer the greatest security and usefulness of said collections."

Dr. Brinton read the following letter from the Department of Archæology of the University of Pennsylvania, requesting the deposit of the Keating-Poinsett collection :

PHILADELPHIA, January, 1893.

TO DANIEL G. BRINTON, M.D.,

Secretary of the Philosophical Society :

Sir :—The Board of Managers of the Department of Archæology and Palæontology of the University of Pennsylvania, understanding that the Philosophical Society is holding under consideration the disposal of a collection of objects of archæological and ethnological interest, known to the public as the "Poinsett Collection," has instructed me to place before your Society a request that the above-named collection be deposited at the Museum of the University of Pennsylvania.

In so doing, I wish respectfully to submit to your Society the following facts :

The Museum of Archæology and Ethnology of the University was founded for the precise purpose of advancing, in this city, the sciences, the names of which appear in its title, and already possesses large and valuable collections, illustrative of the development of man and civilization.

It, moreover, disposes of the services of a competent staff of special scholars, fully qualified to scientifically classify, properly label, and thoroughly "work up" such collections, and to display them to the very best advantage for the use of students.

An isolated collection, containing specimens of the arts and industries of man, as founded upon a few disconnected points—such as the one now at the disposal of the Philosophical Society—however valuable it may be, is practically of very limited use to science. But made to fill an important place in a large ethnological series—where the story it tells forms an interesting chapter of scientific research in the history of mankind—it becomes of priceless value to scholars, and is a link in the long chain of human evolution.

In respectfully submitting the above to the consideration of the Philosophical Society, the Department of Archæology and Palæontology of the University of Pennsylvania pledges itself—if its earnest request be granted—to give the collection the very best accommodation ; to provide suitable cases ; to display, classify and label it with the most conscientious care, and to spare no pains to insure its preservation, and to make it of the highest possible value to scholars and to the general public.

I remain respectfully yours,

SARA Y. STEVENSON, *Secretary pro tem.*

After discussion, on motion of Dr. J. Cheston Morris, the matter was referred to the Council of the Society.

And the Society was adjourned by the Presiding Member.

Stated Meeting, February 17, 1893.

Dr. J. CHESTON MORRIS in the Chair.

Correspondence was submitted as follows:

A letter from the Société Impériale de Minéralogique, St. Petersburg, announcing the death of its Director, Hon. Nicolas Kokcharow; also the death of its member, Hon. Axel Gadoline.

A letter from the I. R. Accademia degli Agiati, Rovereto, Austria, announcing the death of its member, Prof. D. Giuseppe Pedessalli.

A circular from Columbia College, New York, announcing the regulations for 1893 concerning the Loubat Prize.

A circular from the Bureau of Education, Washington, D. C., in regard to the Educational Exhibit of the World's Columbian Exposition.

Letters of envoy were received from the Geological Survey of India, Calcutta; Royal Statistical Society, Meteorological Office, London, Eng.; Mr. William John Potts, Camden, N. J.; Treasury Department, Washington, D. C.

Letters of acknowledgment (139) were received from the Nova Scotia Institute of Science, Halifax; Geological Survey, Dr. Alfred R. C. Selwyn, Ottawa, Canada; Hon. J. M. Le Moine, Quebec, Canada; Canadian Institute, Toronto; Manitoba Historical and Scientific Society, Winnipeg; Society of Natural History, Portland, Me.; N. H. Historical Society, Concord; Dartmouth College, Hanover, N. H.; Amherst College Library, Amherst, Mass.; State Library of Massachusetts, Public Library of Boston, Massachusetts Historical Society, Boston Society of Natural History, Massachusetts Institute of Technology, Prof. Thomas M. Drown, Messrs. S. P. Sharples, Robert C. Winthrop, Boston, Mass.; Museum of Comparative

Zoölogy, Mr. Robert N. Toppan, Cambridge, Mass.; Free Public Library, New Bedford, Mass.; Essex Institute, Salem, Mass.; American Antiquarian Society, Worcester, Mass.; Profs. O. C. Marsh, Hubert A. Newton, W. D. Whitney, New Haven, Conn.; Albany Institute, Prof. James Hall, Albany, N. Y.; Society of Natural Science, Buffalo, N. Y.; Prof. Edward North, Clinton, N. Y.; Profs. B. G. Wilder, J. M. Hart, Ithaca, N. Y.; American Museum of Natural History, N. Y. Mathematical Society, Astor Library, New York Hospital, Historical Society, Prof. J. J. Stevenson, Messrs. R. S. Hayes, R. W. Raymond, New York; Vassar Brothers Institute, Poughkeepsie, N. Y.; Oneida Historical Society, Utica, N. Y.; U. S. Military Academy, West Point, N. Y.; Prof. Henry M. Baird, Yonkers, N. Y.; Free Public Library, Jersey City, N. J.

Accessions to the Library were reported from the Geological Survey of India, Calcutta; Asiatic Society of Japan, Tokyo; K. Danske Geografiske Selskab, Copenhagen; État Indépendant du Congo, Bruxelles, Belgium; Société Hongroise de Géographie, Budapest; Naturforschende Gesellschaft, Freiburg i. B.; Université de Lyon, France; Messrs. Bela de Gonda, Paul Topinard, Paris, France; Académie R. des Sciences de Lisbonne, Commission des Travaux Géologiques de Portugal, Lisbon; R. Statistical Society, Meteorological Council, Dr. Henry Calderwood, London, Eng.; Philosophical Society, Glasgow, Scotland; Theological Seminary, Andover, Mass.; Brown University, Providence, R. I.; University of the State of New York, Albany; American Chemical Society, Astor Library, American Museum of Natural History, New York; Academy of Natural Sciences, Mercantile Library, Historical Society of Pennsylvania, Wagner Free Institute, Messrs. Abraham Jordan, Benjamin Smith Lyman, Henry Phillips, Jr., Philadelphia, Pa.; Enoch Pratt Free Library, Editor of *Journal of Philology*, Baltimore, Md.; Treasury Department, Lighthouse Board, Dr. Albert S. Gatschet, Washington, D. C.; University of California, Sacramento; State University of Iowa, Iowa City; Historical Society of the State of Montana, Helena; Agricultural Experiment Stations, Burlington, Vt., Amherst, Mass., Des Moines, Ia.

Dr. Charles S. Dolley read a paper on "The Thyrsus of Dionysos and the Palm Inflorescence of the Winged Figures of Assyrian Monuments."

This being the regular evening for balloting for candidates for membership, pending nominations Nos. 1235, 1251, 1252 and 1254 were read, spoken to and voted upon.

New nominations Nos. 1255 and 1256 were read.

Pending nomination No. 1249 was referred to Council.

Pending nominations Nos. 1250 and 1253 were postponed until May 19, in consequence of the absence of the proposers.

The Proceedings of the Board of Officers and Council were submitted, and under the call of New Business, were taken up and considered.

On motion, the resolution of Council suggesting the withdrawal of the deposits of the Society was made the special order for March 17.

The following preambles and resolution, offered by Dr. Rothrock, were adopted by the Society:

Whereas, The forests of Pennsylvania, which are of such vast importance to the future prosperity of the State, are being removed, and no serious attempt is being made towards their restoration; and,

Whereas, The problem growing out of this condition of affairs is a complicated one, for the solution of which, by wise legislation, sufficient information is not available; therefore, be it

Resolved, The American Philosophical Society respectfully requests the members of the Senate and House of Representatives to vote in favor of a bill entitled "An Act Relative to a Forestry Commission," which has been introduced into the House of Representatives of Pennsylvania by the Hon. D. Smith Talbot, of Chester county.

The ballots cast for candidates for membership having been counted, the Tellers reported the result to the Presiding Member, who declared the following gentlemen to have been duly elected members of the Society:

2210. M. Hippolite Taine, Menthone, Haute Savoie, France.

2211. Charles Schaeffer, M.D., Philadelphia.

2212. Prof. George Lincoln Goodale, Cambridge, Mass.

2213. Hon. Robert E. Pattison, Harrisburg, Pa.

And the Society was adjourned by the Presiding Member.

Description of the Original Manuscript Journals and Field Notebooks of Lewis and Clark, on which was based Biddle's History of the Expedition of 1804-6, and which are now in the possession of the American Philosophical Society in Philadelphia.

By Dr. Elliott Coues, Washington, D. C.

(Read before the American Philosophical Society, January 20, 1893.)

It is well known that the *History of Lewis and Clark's Expedition* was written by Mr. Nicholas Biddle, of Philadelphia, and first published there in 1814, in two octavo volumes, by Bradford and Inskip. It is also common report that the manuscripts of the famous explorers, upon which Mr. Biddle worked, are extant. But what these are, and where they are kept, few could have told.

All the Journals and Notebooks, in the handwritings respectively of Lewis and of Clark, upon which Mr. Biddle based his work, were deposited by him with the Philosophical Society in April, 1818. I have before me his original letter, of date April 6, 1818, making the deposit; also a copy of the receipt given by the Society. Both of these papers I owe to the kindness of Judge Craig Biddle, who also placed in my hands about fifty other documents, mainly Clark-Biddle correspondence relating to the preparation and publication of the work.

By the terms of this deposit, as accepted by the Philosophical Society, William Clark, his heirs or assigns, were and are always to have access to and use of these manuscripts for the preparation of any other edition of the work.

Mr. Jefferson K. Clark, of St. Louis, the only surviving son and heir of William Clark, very kindly furnished me with a letter to the Philosophical Society, desiring the manuscripts to be placed at my disposition for the preparation of the edition which I have now (Dec., 1892) in press.

I lately spent a week in the rooms of the Society, making there a preliminary study of the manuscripts, during which I was favored by Mr. Henry Phillips, Jr., the Secretary and Librarian, with every attention and facility. But finding it impossible to do the necessary work in the few days I could spend in Philadelphia, I preferred a formal request to be put in possession of the manuscripts for a limited period. By vote of the Society in open meeting, December 16, 1892, this request was granted, promptly and with great liberality; and the whole of the material thus passed into my hands.

Diligent and minute examination of these manuscripts satisfies me that their character should be made known, as a matter of great historic interest. Accordingly the present description is offered.

I will first describe the bound books and loose papers, just as I found them, in general terms; next, in terms of their several deposits—for there are more of them than Mr. Biddle deposited; and then I will give an

account of them in detail, as I have arranged them in a series of codices, which I call alphabetically Codex A, etc., to T.

I. THE BOOKS AND PAPERS AS FOUND.

Of four sorts : (1), (2), (3), three different styles of bound field Notebooks and Journals ; (4), several lots of loose papers, mainly belonging with one of the styles of the bound volumes.

1. Thirteen (13) bound volumes, all alike, forming the most conspicuous part of the collection, and known since Biddle's time as "the red books." These are Journals and Notebooks of Lewis and of Clark, respectively, all in the handwriting of one or the other of the explorers. Eleven (11) of these are a part of the Biddle deposit ; one (1) was deposited by Mr. Jefferson ; one (1) is an unrecorded deposit. All are in remarkably good order, clean and sound inside and out ; form oblong ; back along short diameter, and as the pages were written on both sides, up and down, across the same diameter, the books open to and from the reader, not right and left ; covers smooth bright *red* morocco, gilt-tooled edges, marbled inside, fastened at the fore end with brass clasps (now gone from eight of the volumes, intact on five of them) ; size of covers $8\frac{1}{8} \times 5\frac{1}{8}$ inches (very nearly same size and shape as the leaves of the printed Philadelphia edition of 1814) ; paper about one quarter inch smaller each way than cover, or $7\frac{7}{8} \times 4\frac{3}{8}$, rather thin, rough and tough, white (now with a slight brownish tinge), unruled ; gathering supposed to be 76 folios or 152 pages in each book, exclusive of a pair of flyleaves marbled one side like inside of cover ; but the number of leaves varies a little, and in several cases some leaves have been intentionally torn out—nowhere breaking the text, but to write something else on, or for another purpose. These books, as a whole, are written almost entirely full. Lewis' hand is particularly fine, fair and even ; Clark's is larger, stronger and less regular ; both are so good, and the pages are so perfectly preserved, that there is perhaps not a word, possibly not a letter, in the whole of these manuscripts not now distinctly legible. Seven (7) of these thirteen books are by Lewis alone ; six (6) are by Clark alone. Eleven (11) are "Journals"—*i. e.*, narratives of the progress of the Expedition day by day, entered under consecutive dates. Two (2) are "Notebooks"—*i. e.*, miscellaneous entries, of various dates or none, of astronomical, geographical, ethnological, zoölogical, botanical, etc., items. In my arrangement these thirteen books become Codices D, E, F, G, H, I, J, K, L, M, N, O, P (see further on). With them belong more or less intimately certain parcels of loose sheets (see on).

2. One (1) bound volume, the "brown" book, standing alone. This is almost exactly the size, shape, etc., of the foregoing, but quite unlike them in appearance. It is bound in rough brown leather, sides and edges alike, not marbled inside ; it is thicker than any of the other volumes, the paper being heavier and coarser ; the leaves are 137, pages 274. This

is mainly a Journal, and mainly in Clark's hand, but with some entries by Lewis, and some by another hand. It includes the whole of the wintering of the Expedition at Fort Mandan, and various other matters. For contents see beyond, Codex C, which this volume now forms.

3. Four (4) bound volumes, which may be called the "marble" books, from the style of their covers. Form oblong, like that of all the foregoing; size of covers $6\frac{3}{4} \times 4$ inches, leaves $6\frac{1}{2} \times 3\frac{3}{4}$; paper rough, whitish, unruled; covers pasteboard, overlaid with marbled paper, back and corners of thin, smooth, brown leather. All in good order but one, which is worn and shabby; all written full, and perfectly legible throughout. The gathering of these four books is supposed to be 92 leaves or 184 pages; in one I find but 164 pages, though without any break in the text that I can discover. Two of these books are Clark's Journals, from the starting of the Expedition to October 3, 1804; the other two are Notebooks, chiefly natural history notes, by both Lewis and Clark. The four now form my Codices A, B and Q, R (see beyond).

4. Several parcels of loose sheets of manuscript, some in Lewis' hand, some in Clark's. Most of these papers are of the same size, shape and quality as the leaves of the red books, having been, in fact, taken from some of the latter, as may be seen by fitting the torn ends to the stubs remaining in the volumes. Those parcels which thus obviously belong to certain of the red books, or with the red books as a set, I have arranged as Codices Fa, Fb, Fc, Fd, Fe, La, Lb. One of the parcels is a different fragment, imperfect, once part of a Notebook, not found, like the small marble books; this is now Codex Ia. Two of the parcels belong with the small marble books, and thus become Codices Aa, Ba. Two remaining parcels, not directly connected with any of the bound volumes, are now Codices S, T. These manuscripts were all loose; as arranged they make twelve (12) parcels and as many codices, for the particular description of which see beyond.

The above are all the books and papers in my hands which are actual manuscripts of Lewis or of Clark. They are accompanied by Mr. Biddle's letter of deposit, and several memoranda concerning them, in Biddle's or another hand.

II. THE BOOKS AND PAPERS AS DEPOSITED.

I do not find quite all of the Biddle deposit, as itemized in the receipt given him by the Society; for example, no vocabularies and no maps. The "Meteorological Register" he specifies is simply certain leaves detached from the red books, and thus already accounted for. All the loose manuscript above specified is supposed to be included in the Biddle deposit. But I find four books from other sources remaining to be accounted for. As to their deposits, therefore, the Lewis and Clark manuscripts fall into the following arrangement:

1. The Biddle deposit, fourteen bound volumes, viz.: Two of the four

small marble books ; the one brown book ; and eleven of the thirteen red books. With these belong all the loose papers, as above said.

2. The Jefferson deposit, consisting of three bound volumes. Two of these are small marble books, matching the other two deposited by Biddle. Each is by both Lewis and Clark, and each consists of miscellaneous field notes, mainly on zoölogy and botany. They now form Codices Q, R. The third volume is one of the red books. It is a Clark, and contains miscellaneous notes, chiefly on natural history. It is now Codex P. These three were deposited by Mr. Jefferson in November, 1817, as appears by memorandum in each of them, in Biddle's hand.

3. Unknown deposit : One of the thirteen red books, without record of source whence obtained. This is a Lewis, and consists of certain astronomical observations and geographical notes. It is now Codex O.

III. THE BOOKS AND PAPERS AS ARRANGED.

I have gone very carefully through these precious manuscripts, and arranged them in what appears to be their natural sequence or logical order. All the red books, making the bulk of the collection, fall easily together, preceded by two of the small marble books and by the brown book, followed by the other two small marble books, and the set of bound volumes is interspersed with the twelve parcels of unbound manuscripts which I have made up from the loose sheets, securely fastened in stiff paper covers, and for the most part interleaved with onion-skin writing paper. I have also paginated the whole of the manuscripts, which can now be cited by codex and page throughout, as if by volume and page of a published work. There is in all upward of 2,000 pages. Description in detail of the now thirty (30) codices here follows :

CODEx A.—One of the four small marbled cover books. Biddle deposit No. 1. Clark's original No. 1. In good order. Folios 92, pages 184. Being CLARK'S Journal, complete, from May 13, 1804, to Aug. 14, 1804. This takes the Expedition from the 1803-4 winter camp on Du Bois or Wood river up the Missouri to the creek on which the Omahas resided (to p. 44, Vol. i, of the printed text).

Contents.—(1) Table of Missouri river distances up to Big Sioux river, canceled in red ink by Clark or by Biddle, inside front cover. (2) Memorandum of wintering, p. 1. (3) Memorandum of the country, p. 2. (4) Journal, May 13-Aug. 14, 1804, pp. 3-179. (5) Tables of latitudes, pp. 180, 181. (6) Astronomical observations, pp. 182, 183. (7) Memorandum of the badger, p. 184. (8) Astronomical observations, inside back cover.

CODEx Aa.—Fragment. Biddle deposit. No number ; collate with Clark Codex A. In good order. Folios 4, loose, torn from a book like one of the red books ; 5½ pages written. Being LEWIS' Journal, of dates May 20 and 15, 1804, covering starting of the Expedition, which Lewis joined at St. Charles on the 20th.

Contents—(1) Blank, p. 1. (2) Entry May 20, 1804, pp. 2-6. (3) Entry May 15, 1804, pp. 6, 7. (4) Blank, p. 8 (memorandum in another hand, "Part of No. 1").

CODEx B.—One of the small marbled cover books. Biddle deposit No. 2. Clark's original No. 2. In good order. Folios 90, pages 180, counting front flyleaf; one leaf and the flyleaf gone at end, but no break in the MS., which continues on from p. 180 to inside of cover. Being CLARK'S Journal, complete, from Aug. 15, 1804, to Oct. 3, 1804. This takes the Expedition from the creek on which the Omahas resided to next day beyond Caution island (pp. 44-97 of Vol. i, of the printed text).

Contents.—(1) Blank, front flyleaf, p. 1. (2) Memorandum of Corvus bird, back of flyleaf, p. 2. (3) Journal as said, pp. 3-180, and on to inside back cover. (4) Memorandum of pay due men, inside back cover. Item, Clark's classification of Sioux tribes, pp. 56, 57. Item, description of the celebrated "fortification" on Bon Homme island, pp. 66-69 (but the sketch map of this natural formation is in Codex N, one of the red books, and only half of this was engraved for the copperplate facing printed p. 63, Vol. i).

CODEx Ba.—Fragment, torn from a book like one of the red books. Biddle deposit. No number; collate with Clark Codex B. In fair order; some corners gone; loose folios 4, pages $7\frac{1}{2}$ written. Being LEWIS' Journal, Sept. 16 and 17, 1804, when the Expedition was at Corvus creek.

Contents.—(1) Two entries, at dates said, pp. 1-8; Corvus creek named; antelope described, etc. See printed text, pp. 72, 73 of Vol. i. (2) Memorandum in another hand, "This a part of No. 2," reversed on p. 8. The fragment ends in the middle of a sentence on middle of p. 8.

CODEx C.—The brown leather cover book above described, and which may be also known as "The Mandan Codex." Biddle deposit No. 3. Clark's No. 3. Biddle's No. 3. In perfect order. Folios 137, pages 274, and inside of both covers written over. Being CLARK'S Journal, complete, traversing dates Oct. 1-3, 1804, from Codex B, then of dates Oct. 4, 1804, to April 7, 1805, when the Expedition left Fort Mandan; LEWIS enters Feb. 3-13, 1805, when Clark was away on a hunt; another hand invoices, etc. This Journal covers route from Cheyenne river to the Mandans, and residence there.

Contents.—A. Reading forward: (1) Indian memorandum, inside front cover. (2) Botanical memorandum, lengthwise on p. 1. (3) Clark's Journal, Oct. 1, 1804, to Feb. 2, 1805, pp. 2-160. (4) Lewis' Journal, Feb. 3-13, 1805, pp. 160-174. (5) Clark's entries of his hunting trip, Feb. 3-13, 1805, pp. 174-177. (6) Clark's Journal, Feb. 14 to March 21, 1805, pp. 178-198. (7) Lewis' entry of March 16, 1805, pp. 199-202. (8) Clark's Journal, March 22 to April 7, 1805, pp. 202-214; blank p. 215. B. Reading backward: (9) Memorandum of British forts, inside back cover. (10) Baling invoice of sundries for Indian presents, stores, etc., by another hand, pp. 274-256. (11) Sketch map of Red and St. Peter's

ivers, p. 255. (12) Blank p. 254. (13) Summary statement of the rivers, etc., pp. 253-248. (14) Distances of sundry places up the Missouri to the Mandans, p. 247. (15) Weather diary, etc., Jan. 1, 1804, to April 7, 1805, pp. 248-216. (16) Blank p. 215.

Note.—This is one of the most important, as it is also the most miscellaneous, of all the codices. Both Lewis and Clark have a hand in it, as does also another person. The progress of the Expedition covered by it is as above said. It has all the matter of the residence at Fort Mandan. The Journal proper covers pp. 94-178 of Vol. i of the Biddle print, but the codex contains much other matter. Items (1), (2), (9) and (11) were not used by Biddle. Item (10) is a most elaborate invoice of the goods, stores, etc., summarized by Biddle, p. 2 of Vol. i. Item (8) gives on pp. 208-211 a detailed invoice of the natural history specimens, curiosities, etc., sent to Jefferson April 7, 1805. Item (13), the "Summary Statement," is *not* the original of that printed by Biddle, Vol. ii, p. 462 *seq.*, being an early rough draft of Clark's, afterward improved upon in another codex; and it also includes places and distances on the Missouri above the Mandans, and on the Yellowstone, from Indian information gathered before April 7, 1805. Item (15), the Weather Diary and Remarks, is the original of Biddle's print, Vol. ii, p. 476, to the date April 7, 1805, on p. 484, but the corresponding "Remarks and Reflections" of the Biddle print, pp. 495-505, are compiled only in part from this item, in part from another weather diary of same dates.

CODEx D.—One of the thirteen red morocco cover books. Biddle deposit. Biddle's No. 4. In perfect order, brass clasp half remaining. Cover clean and scarcely warped. Folios 70, pages 140, besides two flyleaves marbled one side like inside of covers; there should be folios 76, pages 152, but several leaves are torn out at end (these are preserved, being now part of Codex Fe, which see). This is Lewis' Journal, complete, April 7, 1805, to May 23, 1805, from the Mandans to a little above Musselshell river, and *corresponding* in dates with Biddle's pp. 177-226 of Vol. i; but the printed text follows mainly a Clark Journal I have not found.*

Contents.—(1) Blank, marbled flyleaf and pp. 1, 2. (2) Journal as above said, pp. 3-139. (3) Page 140, reading backward, is the end of the remarks belonging to the weather diary for April to June, 1805, torn out and now a part of Codex Fe. The Journal itself is intact for the dates said. (4) Marbled flyleaf, blank, but for a penciled memorandum of mine to above effect.

CODEx E.—One of the thirteen red morocco cover books. Biddle deposit. Biddle's No. 5. In perfect order inside, brass clasp gone, covers clean, one of them creased crosswise. Folios 78, pages 156, and both

* One of Clark's Journals is now in the possession of his son, Mr. Jefferson K. Clark, of St. Louis. I am not informed of the dates covered by this volume, nor of the nature of its contents.

marbled flyleaves written over one side. Being LEWIS' Journal, complete, pp. 1-156, and both flies, May 24, 1805, to July 16, 1805, carrying the Expedition from North Mountain creek to the Gates of the Rocky Mountains, followed in the Biddle text, mainly, pp. 226-303 of Vol. i.

Contents.—(1) Text of Lewis' Journal as above sufficiently indicated. But also : (2) Colored sketch map of the Great Falls and Portage of the Missouri, pp. 132, 133. This sketch covers the Missouri from the cache near Portage creek up to above Smith's river, with Fort Mountain in the southwest corner ; only about two-thirds of it was engraved for the plate facing p. 261, Vol. i, of the Biddle edition. The scale is "600 poles to the inch," much reduced in the copperplate as engraved.

CODEx F.—One of the thirteen red morocco cover books. Biddle deposit. Biddle's No. 6. In perfect order inside and out, except brass clasp gone. Folios 76, pages 152, and one side of both marbled flyleaves written over = pages 154 ; p. 153, on back fly, continued as p. 154 on front fly. Being LEWIS' Journal, complete and intact, July 17, 1805, to Aug. 22, 1805 (except Aug. 1-4), carrying the Expedition from the Gates to the Three Forks of the Missouri, thence up Jefferson river and over the Rocky Mountains to the Shoshone village ; corresponding to pp. 303-398 of Vol. i, of the Biddle text.

Contents.—As above ; no other matter. See Codex Fa.

CODEx Fa.—Fragment. Biddle deposit. No number. In perfect order. Folios 4, pages 8, loose sheets, written over $6\frac{1}{2}$ pages, same paper as one of the red books. Being LEWIS' Journal, Aug. 1-4, 1805, but merely another narrative of those days, already fully written up at pp. 52-66 of Codex F, with which collate.

Contents.—As just said.

CODEx Fb.—Fragment. Biddle deposit. No number. In perfect order. Folios 13, pages 26, written $25\frac{1}{4}$, loose sheets, same paper as the red books. LEWIS' Journal, Aug. 23-26, 1805, therefore in direct continuation of Codex F. Text mainly the account of the Shoshone Indians as given in Biddle's Chap. xvi, Vol. i. The *dates* are included in Clark's Journal, Codex G.

Contents.—As above said. Verso of folio 13, p. 26, has inked memoranda : (1) "This comes into No. 7 [Codex G] between the 23d and 26th August, 1805," *i e.*, put this account of the Shoshone Indians in text to be got from Clark's Journal of those dates. (2) "This has been copied from W. C. Journal and comes in as above in No. 7 [Codex G]."

CODEx Fc.—Fragment. Biddle deposit. No number. In perfect order. Folios 2, pages 4, full. Loose sheets, paper of the red books. LEWIS' Journal, Sept. 9 and 10, 1805, at and near Traveler's Rest creek. This codex comes after Codex Fb, but not connectedly. The dates are covered by Clark, Codex G.

Contents.—As above.

CODEx Fd.—Fragment. Biddle deposit. No number. In perfect order. Folios 4, pages 8, full. Loose sheets, paper of the red books. LEWIS' Journal, Sept. 18-22, 1805, Hungry creek, Chopunnish Indians, etc. Follows Codex Fc, but not connectedly. Dates covered by Clark, Codex G.

Contents.—As above. At end: (1) Memorandum, "This is a part of Book No. 7 [Codex G] to be referred to and examined after the 9th Sept., 1805.—W. C." (2) Memorandum, "Look forward 4 leaves," in Biddle's hand.

CODEx Fe.—Two fragments. Biddle deposit. No number. In perfect order. Folios $5 + 3 = 8$, pages $10 + 6 = 16$. Paper like that of the red books, from two of which these fragments have been torn. LEWIS' weather diary for April, May and June, 1805, and for July, Aug. and Sept., 1805.

Contents.—(1) April to June, [1805, 5 leaves belonging to Codex D (which see), as the torn ends of the sheets fit the stubs left in the book, p. 140 *seq.* These folios are in fact pp. 141-152 of Codex D, or reading backward, as the weather diary began at end of book, pp. 152-141, continued on to p. 140 of the book with remarks for June, 1805. (2) July to Sept., 1805, 3 leaves, likewise torn from one of the red books.

Note.—This codex is the basis of Biddle's meteorological tables, April 1 to Sept. 30, 1805, in Vol. ii, pp. 484-488, and of the "Remarks and Reflections" pertaining to these dates, pp. 503-508. By dates Codex Fe is to be collated with Codices D, E, F, G.

CODEx G.—One of the thirteen red morocco cover books. Biddle deposit. Clark's No. 5. Biddle's No. 7. In perfect order inside and out; brass clasp intact. Folios 76, pages 152, besides the marbled flyleaves, one of which is written on. CLARK'S Journal, complete, July 1, 1805, to Oct. 10, 1805, covering the whole of the route from White Bear islands, at the head of the Great Falls of the Missouri, to the mouth of the Kooskooske or Clearwater river.

Contents.—(1) Certain distances and latitudes, p. 1 and overrun on front flyleaf. (2) Journal, dates as above, pp. 2-150. (3) Blank, pp. 151, 152, and back flyleaf. This narrative is the main basis of Biddle's pp. 289-end of Vol. i, though of course the parallel narrative of Lewis is collated in its proper connections. It is utilized by Biddle for the dates in which it laps back over Lewis Codex F.

CODEx H.—One of the thirteen red morocco cover books. Biddle deposit No. 8. No Clark number. In perfect order, inside and out; brass clasp intact. Folios 76, pages 152, besides back and front marbled flyleaves. CLARK'S Journal, complete, Oct. 11, 1805, to Nov. 19, 1805, going down "Lewis'" river and the Columbia to the mouth of the latter.

Contents.—(1) Biddle's memorandum for engraving plates, verso of front flyleaf. (2) Colored sketch map of Great Falls of the Columbia, scale 200 yards to the inch, p. 1 and overrunning on fly. (3) Colored

sketch map of Long and Short Narrows of the Columbia, continuously on pp. 2 and 3, scale 426 poles to the inch. (4) Colored sketch map of the Great Shoot or Rapid of the Columbia, same scale, p. 4. (5) Journal as above said, pp. 5-152, including colored sketch map of "Lewis'" river, etc., p. 33.

Note.—Codex II is main basis of Biddle, Vol. ii, pp. 1-81. Of the maps above said, only (2) and (4) were ever engraved. These form two of the three plates of Biddle's Vol. ii.

CODEx I.—One of the thirteen red morocco cover books. Biddle deposit No. 9. No Clark number. In perfect order, inside and out; only brass clasp gone. Folios 78, pages 156, besides the two marbled flyleaves. CLARK'S Journal, complete, Nov. 19, 1805 (directly continued from same date in Codex II) to Jan. 29, 1806, at and about the mouth of the Columbia and residence in Fort Clatsop, with various other matter, for which see contents following.

Contents.—*A.* Reading forward: (1) Blank, p. 1. (2) Estimated distances, etc., mouth of the Missouri to mouth of the Columbia, by the route the Expedition went out, pp. 2-12—not the basis, however, of the "Summary Statement" as printed. (3) Diary of the weather, etc., April, 1805, to Jan., 1806, pp. 13-33. (4) Journal, as above said, pp. 34-144. *B.* Reading backward: (5) List of traders visiting the Columbia, p. 156. (6) Estimate of the Western Indians, pp. 155-147, in the midst of which is (7) colored sketch map of the mouth of the Columbia, p. 152. (8) Three journal entries, Jan. 1-3, 1806, pp. 146, 145.

Note.—Codex I is the main basis of Biddle's printed text, Vol. ii, pp. 80-146, though of course with collation of Lewis' parallel narrative. The list of traders is on Biddle's p. 145. Biddle also uses the weather diary in one part, for the months not taken from Lewis. The sketch map forms the third of the copper plates of Biddle's Vol. ii. But the most important special matter in this Codex is the "Estimate of the Western Indians," an original basis of Biddle's pp. 471-476. The printed pages, however, do not follow this Clark Codex I, but are from some revised manuscript furnished by Clark.

CODEx Ia.—Fragment. Biddle deposit. No number. In perfect order. Folios 5, pages written 8; small paper like that of one of the small marble cover books. LEWIS' Journal, Nov. 29-Dec. 1, 1805, when he explored by himself a place on the S. W. side of the Columbia.

Contents.—(1) Entries Nov. 29 to Dec. 1, 1805, as above said, pp. 1-6, ending abruptly unfinished. (2) A very slight sketch map, Point Adams, p. 7. (3) Fragment of a botanical description, not connected with the rest of the text. (4) Label of the fragment in another hand, p. 8. Lewis' going and coming is noted in Biddle, p. 87 and p. 90, Vol. ii. The fragment should have extended to Dec. 5. Slight as it is, it is significant, as this was the trip on which Lewis discovered and determined upon the site for Fort Clatsop.

CODEx J.—One of the thirteen red morocco cover books. Biddle deposit, No. 10. In perfect order inside and out, only clasp gone. Folios 76, pages 152, besides marbled flyleaves. LEWIS' Journal, complete, Jan. 1, 1806, to March 20, 1806, thus covering the residence of the party in Fort Clatsop. The manuscript is very close, clear and clean, and illustrated with numerous pen and ink sketches of Indian implements and utensils, birds, fishes, etc. There is a well-drawn head of the California condor, the white-fronted goose, and some full-length fishes, size of the page. We will specify this as "The Clatsop Codex."

Contents.—*A.* Reading forward: (1) Sketches, p. 1. (2) Journal as said, pp. 3-145. *B.* Reading backward: (3) Weather Diary, Jan. to March, 1806, pp. 152-145, meeting ending of Journal in the midst of the page. By dates the matter of this codex, as far as the Journal is concerned, is comprised between Biddle's pp. 103-147 of Vol. ii.

CODEx K.—One of the thirteen red morocco books. Biddle deposit. Biddle's No. 10. In perfect order inside and out, only brass clasp gone. Folios 76, pages 152, and two marbled flyleaves. LEWIS' Journal, complete, March 21, 1806, to May 23, 1806, in direct continuation of Codex J, covering voyage up the Columbia and journey over the Bitter-root mountains.

Contents.—*A.* Reading forward: (1) Journal, as just said, pp. 1-147, includes a sketch map of the Multnomah river, p. 28. *B.* Reading backward: (2) Weather diary, April and May, 1806, pp. 152-147, meeting the Journal near bottom of the page.

Note.—The Journal of this codex, so far as it is utilized, makes Biddle's pp. 205-299 of Vol. ii.

CODEx L.—One of the thirteen red morocco cover books. Biddle deposit. Biddle's No. 12. In good order inside and out, brass clasp intact. Total folios 75, pages 150, inclusive of three folios I have fastened in where they belong, exclusive of the two marbled flyleaves, both written on one side. LEWIS' Journal, not complete, May 24, 1806, to Aug. 8, 1806, excepting July 5-14, which is Codex La, completing the Journal between dates said. This Codex L, together with La, covers the making of "Lewis and Clark's Pass," Lewis' exploration of Maria's river, and his Indian fight. It is continued by Lb, which see.

Contents.—(1) Astronomical memorandum, verso front fly. (2) Journal, May 24 to July 4, pp. 1-80. (3) Blank pp. 81-98, left so by Lewis to copy in here the Journal of July 5-14, which is now Codex La. (4) Journal, July 15 to Aug. 8, pp. 99-144, where text calls for a supplement, which supplement is my Codex Lb, Lewis' Journal, Aug. 9-12, 1806, and end of all his Journals. (5) Weather diary, June, July, Aug., 1806. (6) A memorandum of the traders Dickson and Hancock, on back flyleaf.

Note.—This codex, with its important belongings La and Lb, is the sole basis of Biddle's Vol. ii, pp. 332-365, relating to Lewis' party, at the dates said separated from Clark's.

CODEx La.—Fragment. Biddle deposit. No number. In poor order; one sheet in bad order. Sheets $4\frac{1}{2}$, folios 9, pages 18, of a folded note-paper, not matching paper from any of the bound books, and one sheet not matching the rest. LEWIS' Journal, July 3-15, 1806, the making of "Lewis and Clark's Pass." We will call it "The Pass Codex."

Note.—This is by far the most important of all the fragments, and unhappily in the worst order of all the manuscripts. Sheet 1, folios 2, pages 4. is larger than the rest, thin and now very brittle. Having been handled and picked with smaller sheets, the edges are ragged, especially at bottom. The last line on each of the four pages was probably going in Biddle's time, for he has interlined some words that were then in danger of becoming illegible. Others that were only made out with difficulty when I got the manuscript I have interlined to like purpose; and certainly every word is saved. The top was in the same state, but has no lines so near the edge, and I have trimmed it smooth. This sheet is badly stained, also, perhaps from getting wet when Lewis forded a river with it in his pocket. The Pass is made July 7, at the bottom of p. 7 of this fragment. The MS. ends illegibly near the bottom of p. 18. Two other hands make a memorandum across the blank space, to the effect that this fragment belongs to Biddle's No. 12, my Codex L, where 10 folios were left blank by Lewis for its insertion, and where it should be carefully copied into the clean book.

CODEx Lb.—Fragment. Biddle deposit. No number. In good order. Folios 4, pages 7 written + 1 blank, paper like that of the red books. LEWIS' Journal, Aug. 9-12, 1806, and last; includes his being shot by Cruzatte.

Note.—Sole basis of Biddle's pp. 363-365, Vol. ii.

CODEx M.—One of the thirteen red morocco cover books. Biddle deposit. Biddle's No. 13. In perfect order inside and out, brass clasp intact. Folios 76, but pages 154, including one side of each marbled flyleaf. CLARK'S Journal, complete, June 7, 1806, to Aug. 14, 1806. Parallel narrative with Lewis' to July 3, when the party separated, then Clark's sole narrative of the journey from Traveler's Rest creek to the Jefferson river, making "Clark's Pass," thence down the Jefferson, up the Gallatin, over to the Yellowstone, and down this to its mouth, below which the separated parties reunited; also weather diary, June to Aug., 1806. This may be known as "The Yellowstone Codex."

Contents.—(1) Chopunnish Indian sketch map of various rivers, pp 1, 2. (2) Journal as said, pp. 3-145. (4) Weather diary, Aug., July and June, pp. 146-152, properly reading backwards. (5) Blank, p. 153. (6) Certain memoranda, p. 154 (back flyleaf).

Note.—The sketch map is that mentioned in Biddle, as drawn by Chopunnish Indians and copied on paper by Clark. It was never engraved. With Lewis' parallel narrative to July 3, this codex is the basis of Biddle, Vol. ii, pp. 309-332: then it is sole basis of pp. 366-404.

CODEx N.—One of the thirteen red morocco cover books. Biddle deposit. Biddle's No. 14, and last. In perfect order inside and out, only brass clasp gone. Folios 76, but pages 154, one side of both flyleaves being written over. CLARK's Journal, complete, Aug. 15 to Sept. 26, 1806, and his last, bringing the reunited party down the Missouri to St. Louis; also various other matter (see contents).

Contents.—*A.* Reading forward: (1) Memorandum of articles forwarded from St. Louis to Louisville, Ky., pp. 1, 2 (one side of front fly and next page). (2) Journal as above said, pp. 3-78. (3) Blank, pp. 79, 80. (4) Sketch of the "Ancient fortification on Bon Homme island," pp. 81, 82; text to the same, pp. 83-85. (5) Blank, pp. 86-121. *B.* Reading backward: (6) Certain natural history notes, pp. 154, 153. (7) Weather diary, Sept., 1806, pp. 152, 151. (8) Important sketch map of the "River of the Road to Buffalo," locating "Lewis and Clark's Pass," etc., pp. 150, 149; never engraved. (9) Courses and distances from Traveler's Rest creek to the Great Falls of the Missouri, pp. 143-144. (10) Summary Statement of the Rivers, etc., "by Capts. Lewis and Clark," pp. 142-133. (11) Summary Statement of the Yellowstone distances, etc., pp. 132, 131. (12) Portage from the Yellowstone to the Three Forks of the Missouri, pp. 130, 129. (13) Various notes, pp. 128-122.

Note.—An important codex. As Lewis kept no Journal after Aug. 12, 1806, when he had been shot, the remainder of Biddle's Vol. II is based on this codex, as far as p. 433, end of the History. "The Summary Statement," item (10) above, in Clark's hand, forms pp. 462-470 of Biddle's appendix; it is printed almost word for word. Items (11), (12) and (13), however, were never printed.

CODEx O.—One of the thirteen red morocco books. No Biddle number. Not deposited by Biddle; perhaps by Jefferson; by whom unknown; not one of the regular series of Journals. In perfect order inside and out; brass clasp intact. Folios 64 only, pages 128 only, exclusive of the two flyleaves, probably up to the usual 72 folios, cut out of end. Text as far as it goes perfect and signed "Meriwether Lewis," showing end there. Whole MS. is in LEWIS' hand. The gone leaves were probably taken to be used for other writing, and their absence in no way affects what is in the book (see contents).

Contents.—(1) Entry "Camp ten miles above the mouth of the river Platte, July 22, 1804," p. 1, and following to p. 5 is description of the astronomical instruments used on the Expedition. (2) Astronomical observations for latitude and longitude, May 18, 1804, to March 30, 1805, pp. 6-52. (3) Blank, pp. 53-58. (4) Torn out, 4 folios, pp. 59-66, but no text broken. (5) Blank, pp. 67, 68. (6) Description of the Missouri and other rivers, etc., from the mouth of the Missouri to the Mandans, according to the observations of the Expedition, and beyond the Mandans upon Indian and other information, pp. 69-128. This is a connected general account, the original draft of which was doubtless written at Fort Mandan, winter of 1804-5, as text to accompany the map which was sent

thence to President Jefferson, April 7, 1805. Hence I infer that the substance of this codex was among the papers dispatched to the President at that date; but I have no record of how or when it came into the possession of the Philosophical Society. It does not seem to have been known to Biddle, or at any rate was not used by him in writing the history of the Expedition. (7) Torn out, p. 129 to end.

CODEx P.—One of the thirteen red morocco cover books. No Biddle number. Not one of the regular Journals. Jefferson deposit, Nov., 1817. In perfect order inside and out; only brass clasp gone. Folios only 68, pages 136, exclusive of two flyleaves written on; 4 folios = 8 pages gone, but no break in the manuscript. CLARK'S Natural History Notes, etc., April 9, 1805, to Feb. 17, 1806 (see contents).

Contents.—*A.* Reading forward: (1) Memorandum of weather, Feb. 28 to March 28, 1804, on front flyleaf and p. 1. (2) Memorandum of Jefferson's deposit of this Codex, in Biddle's hand, across p. 1. (3) Missing 4 leaves, pp. 3-10. (4) Blank, pp. 11, 12. (5) Numerous and various zoölogical and botanical notes, at entries of dates above said, pp. 13-124 (missing pp. 80-84). *B.* Reading backward: (6) Some money accounts, canceled, on one side of back flyleaf. (7) Blank, pp. 136-134. (8) Memorandum, p. 133. (9) Blank, p. 132. (10) Weather diary, July, Aug., Sept., 1805, pp. 131-125.

Note.—This codex is important in item (5), which is the main though not the sole basis of Biddle's natural history chapter vii, in Vol. ii. Some of this chapter is almost literally from this codex, but zoölogical and botanical matter from various other codices is there compiled. I may here give the simple explanation of the extreme meagreness and paucity of the natural history notes in Lewis and Clark, with the sole exception of what is in Chap. vii, Vol. ii. It was intended that Dr. B. S. Barton should work up the natural history in both branches, as stated by Biddle in the Preface which he allowed Paul Allen to sign. The codices (Journals) are everywhere rich in such materials—often giving elaborate descriptions of animals and plants which the printed text barely mentions. These manuscripts will doubtless suffice for the scientific identification of the objects described, in nearly all cases. But these passages are almost always canceled in red ink by Biddle or by Clark, with the remark, "Dr. Barton," "Copy for Dr. Barton," "Copied for Dr. Barton," etc., showing that the editor designedly passed them by for the purpose thus indicated. But Dr. Barton never did anything with this wealth of new material; his death occurred soon after the volumes were published, and nothing that I know of bearing on the zoölogy and botany of Lewis and Clark was ever found among his papers. Thus the whole intention miscarried; what little zoölogy was ever made out of the expedition was done by Wilson, Ord and Rafinesque, mainly, and what little botany, I think, by Pursh. In 1876 I worked out the mammals and birds as well as I could from the printed text of Chap. vii, Vol. ii.

CODEx Q—One of the four small marbled cover books. No Biddle number. Jefferson deposit. In good order. Folios 92, pages 184. LEWIS and CLARK'S Miscellaneous Notes, chiefly on natural history, 1804-1806. A mate to Codex R (see contents).

Contents.—(1) Biddle's memorandum of Jefferson's deposit of this codex, inside front cover. (2) Blank, pp. 1, 2. (3) Lewis' natural history notes, pp. 4-24. (4) Blank, pp. 25-30. (5) Lewis' natural history notes, pp. 31-45. (6) Blank, pp. 46, 47. (7) Lewis' natural history notes, pp. 48-56. Lewis' notes run consecutively by dates, entries being from Aug. 2, 1804, to May 9, 1805. (8) Clark's natural history notes, pp. 57-181. Clark's notes are by dated entries, but in no consecutive order. (9) Blank, pp. 182-184.

Note.—This and R are the only codices of the whole series of which Lewis and Clark are joint authors—though Lewis has a few entries in Clark Codex C. I observe no marks by Biddle in the MS, and probably he did not use this codex at all. It has some valuable descriptions, found nowhere else, but on the whole is of much less importance to the naturalist than Codex P. It was long in Mr. Jefferson's hands, and deposited by him in Nov., 1817.

CODEx R—One of the four small marbled cover books. No Biddle number. Jefferson deposit. Cover most worn of any of the books, and very shabby; inside sound and clean, except a torn flyleaf. Folios 82, pages 164. LEWIS and CLARK'S Miscellaneous Notes, chiefly on botany and zoölogy, May, 1804, to March, 1806. A mate to Codex Q (see contents).

Contents.—(1) Biddle's memorandum of Jefferson's deposit of the book, inside front cover. (2) Half of the same memorandum duplicated on the torn p. 2. (3) Blank, p. 3. (4) Lewis' Botanical Register; List of specimens of plants, Nos. 1-108, entered May 10, 1804, to Nov. 17, 1804, pp. 4-49. (5) Lewis' Zoölogical Notes, Fort Clatsop, Dec. 18, 1805, pp. 50-53. (6) Blank, pp. 54-58. (7) Clark's Botanical and Zoölogical Notes, Fort Clatsop, Feb. 18 to March 11, 1806, pp. 59-162. (8) A memorandum of "lava" by Lewis, p. 163. (9) Blank, p. 164. (10) Word "mineralogy," and memorandum of a bird, inside back cover.

Note.—The same remarks apply to this as to Codex Q.

CODEx S.—Fragment. Biddle deposit. Loose sheets 4 = folios 8 = pages 16, of notepaper, unlike the paper of any of the bound codices. In good order. LEWIS, Two letters of.

Contents.—(1) Letter to President Jefferson, dated St. Louis, Sept. 23, 1806, announcing the return of the Expedition. This is the rough original, full of interlineations and erasures, from which a fair copy was doubtless made and mailed to the President, Lewis retaining the present MS. It is of great historic interest as a curiosity, but of no special value otherwise. It is complete, with official signature and address; it makes 5½ folios, or 11 pages, the second letter being on the same sheets as the

first one, occupying the remaining $2\frac{1}{2}$ folios, or 5 pages. (2) A letter, fragmentary, without signature or address, presumably intended for the President, in Lewis' hand, misdated St. Louis, Sept. 21 (probably meant for 24), 1806, and proceeding to give a general account of the Expedition, till it breaks off in the middle of a sentence at bottom of p. 16. It announces the discovery of the Yellow Rock or "Roghejone" river—that is, of the Yellowstone or Roche jaune.

CODIX T.—Fragment. No record or identification. One folio, 2 pages, apparently Clark's hand, but "Capt. Clark" spoken of in the third person. It is a half sheet of notepaper, not from any one of the bound books, and a mere excerpt, without proper beginning or end, speaking of some geographical and other matters of no special consequence.

Note to Codices A-T.—The four small marble cover codices, and the brown codex, were actually penned in the field, day by day, as the Expedition proceeded. So were some of the fragmentary codices, notably the "Pass Codex." But this cannot have been the case with the red books, nor with those of the fragmentary codices which are on paper of the same size, shape and quality as that of the red books. The covers are too fresh and bright, the paper too clean and sound, for these books to have ever been through the wear and tear of such a journey. The handwritings are too good, and too uniform, for either of the explorers to have executed them in the vicissitudes of the camp. The red books were certainly written after the return of the Expedition, and before Lewis' death in October, 1809—that is, in 1806-9. They were certainly put in Mr. Biddle's hands very early in 1810, and were probably written at St. Louis. I suppose the explorers bought a stock of these blank books, and proceeded to copy into them their Journals and Notes, from rough field-books like the marble ones and the brown one. They appear to have agreed upon a fair division of the work of authorship—each to write certain portions of the narrative, each in the first person singular speaking of the other in the third person, and each drawing what he wished from the rough field-books of both. They evidently intended to become the joint authors of their own Travels, though each should write certain portions himself. This design was frustrated by Lewis' untimely and tragic death; upon which Clark at once secured Mr. Biddle's invaluable services as editor and virtual author. But in making this explanation concerning the red books, I must not be misread as saying that they are not "original" manuscripts of Lewis and of Clark; simply that they are not books which were written in the field. Every word of them all is in the handwriting of one or the other of the explorers; they are original, they are genuine, and they are authentic.

With the foregoing codices, all "Lewis and Clark," are certain papers which need not be codified therewith, but which may be mentioned here. These are:

Paper 1.—Letter of Nicholas Biddle, in his handwriting, dated Philadelphia, April 6, 1818, addressed to Hon. William Tilghman, Chairman of

the Historical Committee of the Philosophical Society, making the deposit of fourteen of the volumes which form part of the above codices, etc.; 1 sheet letter paper, 2 folios, 4 pages, the last $\frac{1}{2}$ blank, endorsed in another hand "received and read to the Historical Comme., April, 1818, see Minutes." It is an important record. I have also in hand (from Judge Craig Biddle) the rough draft whence this clean copy was made.

Paper 2.—A memorandum in Mr. Biddle's hand of Mr. Jefferson's deposit (Nov., 1817) of three bound volumes of the Lewis and Clark Journals and Notes. A mere slip of paper. I have added in my hand a memorandum of these volumes, which are above Codices P, Q, R, making with the fourteen bound volumes of the Biddle deposit, and one of the red books of unascertained deposit, the eighteen books—thirteen red, four marbled, one brown—which I received from the Philosophical Society, December 16, 1892.

Paper 3.—Another memorandum of these codices; a mere slip of paper serving as a label to the books when shelved.

Paper 4.—A memorandum of *intended* illustrations of the published volumes—four for Vol. i, three for Vol. ii. But the engravings actually made do not agree with this memorandum. The paper is a mere slip, written one side, and was found pasted inside the cover of one of the red books.

Paper 5.—A blind memorandum, five items, headed "Papers, &c., of Capt. Lewis, &c." The items speak of "ten or twelve pocket vols., morocco bound;" of some natural history matter, "probably with Dr. Barton's books;" of certain vocabularies, ditto; of certain "observations of Lat. and Long.—of these probably Mr. Patterson knows something;" and of some maps "probably in the hands of the Publishers." It is a small square of letter paper, written one side, and rather a groping after something than any intelligible statement.

Paper 6.—Engraved copperplate of "The Fisher" or pekan, *Mustela pennanti*, perhaps having no connection with Lewis and Clark matters.

Note.—Mr. Biddle speaks in some of his letters of having had the original manuscript Journals of Sergeants Ordway and Gass. I find neither of these. His letter above cited, of April 6, 1818, speaks of the Ordway Journal as having been purchased from that person, and of Governor Clark's desiring, in letter of January 24, 1818, that it should be returned to him (Clark). I have no clue whatever to the Gass manuscript. The printed volume of Gass is of course well-known.

From the manuscripts above described it will be seen at once that the whole history of the Expedition might easily be reconstructed, if this were desirable. Mr. Biddle made a noble narrative, which has become a classic. The question, how closely he followed the original Journals and Note-books, has often been raised but never settled. It is now easy to see that

he wrote the whole work himself, nowhere following the actual words of the explorers themselves in his main text, though using tabular statistical matter literally in his Appendix. Had he done otherwise the world would have been treated to an unexampled curiosity in literature. Biddle's narrative should stand forever as the authentic History of the Expedition; but if the actual texts of Lewis and of Clark are ever published, they should be printed word for word, letter for letter, and point for point. This would make a wonderful book, and I am inclined to think it should be done; but no new editorial narrative need or should ever be made, nor should the Biddle text ever be tampered with. It may be annotated to any extent in the light of contemporaneous criticism, but should itself be left to stand, as a model of methodical, painstaking, precise and judicious editorship.

Judging from the Clark-Biddle correspondence, Mr. Biddle spent two or three years (1810-12) in writing the book, and about as much more time in superintending its publication, which was not finished till February, 1814. Sometimes he worked upon Lewis' manuscript, sometimes upon Clark's; oftener upon both, which he welded together into a third; the resulting text is altogether his, excepting in so far as it was mangled in the press. I presume Mr. Paul Allen is mainly responsible for the shocking punctuation and other errors of the published pages. He had absolutely no joint authorship with Mr. Biddle; he had not the shadow of a claim, that I can discover, to be even mentioned in connection with the work, much less to have his name put on the title-page; he was a mere hack, who received \$500 for some alleged or perhaps imaginary services, not discernible in the light of history; even the Preface, signed "Paul Allen," is Mr. Biddle's; and the memoir of Lewis, ostensibly addressed to Mr. Allen, was secured by Mr. Biddle from Mr. Jefferson. I am utterly at a loss to imagine from what motive Mr. Biddle voluntarily relinquished to another the credit justly due to himself as the actual writer of an immortal book.

The only serious criticism of Mr. Biddle's most admirable performance, which examination of the original manuscripts induces me to venture, concerns the exclusion of all tabular matter from the body of his text. The manuscripts of both the explorers, and of Clark especially, are replete with astronomical observations for latitude and longitude, tabulated courses by points of the compass, bearings of prominent landmarks by the same, formally estimated distances, etc. These are of great intrinsic interest in meandering the Missouri and other rivers, and invaluable in tracking the routes of the explorers across the mountains. It is true that such things do not make easy reading, and perhaps the publisher objected; but the benefit to the student of Lewis and Clark that would have resulted from the publication of these data is simply incalculable.

*Vocabulary of the Kwakiutl Language.**By Dr. Franz Boas.**(Read before the American Philosophical Society, November 18, 1892.)*

The Kwakiutl language is spoken on the coast of British Columbia, from Cape Mudge to Douglas and Gardner Channels, excluding Dean Inlet and Bentinck Arm, which are occupied by the Bilqula. The language forms a branch of the Wakashan stock, being affiliated with the Nootka or Aht of the west coast of Vancouver Island. The form of these languages reminds us in many respects of that of the Salishan stock, and it may be that a connection exists between both.

The Kwakiutl language is spoken in three dialects: the Kwakiutl proper, the Hëiltsuk and the Gyi'tamā't. The first is spoken by the tribes of Vancouver Island and of the coast southeast of Rivers Inlet; the second by the tribes inhabiting the coast between Rivers Inlet and Gardner Channel; the last in Gardner and Douglas Channels. It will be found that phonetics and vocabulary of the northern and southern tribes are much alike, while the middle dialect stands more apart. This is probably due to the admixture of Bilqula elements in the central region.

The vocabularies contained in the following pages were collected by the author in 1886, 1888, 1889, 1890. As slight differences are found between the vocabularies of the various tribes, the tribe from which the words were collected are given. The following abbreviations have been used:

L. for Lē'kwiltok,	}	Kwakiutl Dialect.
N. —Nimkish,		
K. —Kwakiutl,		
TL. —Tlatlasik'oala,		
A. —Awī'ky'ēnoq.	}	Hëiltsuk Dialect.
H. —Hë'iltuk,		
G. —Gyi'tamā't,		

The literature of this language is very scanty. The following writings are of importance:

W. FRASER TOLMIE and GEORGE M. DAWSON, *Comparative Vocabularies of the Indian Tribes of British Columbia*. Montreal, 1884.

G. M. DAWSON, *Vocabulary in Trans. Royal Soc. of Canada*, 1887, ii.

A. HALL, *A Grammar of the Kwagiutl Language*, *Trans. Royal Soc. of Canada*, 1888, ii, pp. 59-105.

F. BOAS, "Grammatical Notes on the Kwakiutl Language," in the "Sixth Report of the Committee on the Northwestern Tribes of Canada," *Proc. British Association for the Advancement of Science*, 1890.

THE GOSPEL according to Saint John, translated into the Qāgūtīl Language. London, 1884 (by Rev. A. F. HALL).

THE GOSPEL according to Saint Matthew, translated into the Qā gūtīl (or Quoquols) Language. By Rev. A. F. HALL. London, 1882.

The following alphabet has been used ; the vowels have their continental sounds :

â = *av* in *law*.

ē = *e* in *flower*.

Consonants.—The following consonants require a special description :

k', g',

k, g,

ky (kH), gy.

This is a series of k sounds beginning with the posterior guttural *k'*, passing through the ordinary *k* to the anterior palatal *ky*. There is a tendency in the Hēiltsuk' dialect to transform *ky* and *gy* into *k* and *g*. The distinction between sonans and media is here, as in many other Indian languages, exceedingly difficult, and it may be that to the Indian ear there is no real distinction between both classes. The same is true in the case of labials and dentals. *s* and *c* (= English *sh*) are evidently modifications of the same sound ; *s* is always pronounced with open teeth and post-alveolar position of the tip of the tongue. Thus it obtains a similarity with *c*, while the latter partakes in the same way of the characteristics of *s*.

q, Q, H correspond to k, k, ky, the first being the German guttural *ch* in *ach*, the last the German palatal *ch* in *ich*, the q an intermediate sound like *ch* in the Westphalian dialect.

The vowels of the Kwakiutl language are extremely variable, and I have not been able to ascertain satisfactorily the meaning of lengthening and shortening, of apparent contractions and dieresis. I had, therefore, to confine myself to give the various forms which I obtained from the Indians. We find a series of very indistinct vowels which are not articulated, but indicated by position of the mouth. The most frequent among these is *u* following a terminal *k*, for which I have used the sign ' ; for instance, in the passive participle —k'. In compounds, when a syllable follows the —k' the *u* is often articulated.

Pauses in words are very frequent, and are almost always accompanied by an increased stress of the preceding consonant. I have found it impossible in this language to distinguish clearly between consonants articulated with ordinary stress and increased stress, although the latter are undoubtedly found, *p. e.*, ky'ē, *no*.

VOCABULARY.

A.

- to be able to compete with somebody*, **N.** lā'kyusta (—usta, *up*); wī'kyusta, *not to be able to get up against* (wī, *negation*; —usta, *up*) = *to rise opposite to somebody?*
- about*, —uili(la); **N.** tlē'kuilila, *moving about*; lākuilila, *camping about, here and there* (lēk'u'la, *to camp*).
- above*, **N. L.** aikH, aikya; **H. G.** aikH; **N.** aikyak'au'ē, *uppermost* (—k'auē, *farthest in a certain direction*); **L.** ai'kyaqala, *from above* (—aqa, *down*; —la, *verb. suf.*); **L.** aikyak'E'miit, *to look up* (—k'E'm, *surface of round thing* = *face*; —nit, *v. a.*); tlāq-k'o-it aikH, *evening sky* = *red above*; **G.** au'kyoa, *upper side* (see *On top of*); **H.** mā'tea, *to fly above*.
- to abuse one another*, **H.** laa'lk'au.
- to ache*, **L.** ts'ē'hila (see *Sick*).
- across*, **N.** —nitla(la); lā'lauitlala, or lā'laōtla, *always going across* (lā—, *to go*).
- Adam's apple*, **H.** k'ōk'oqā'oa (—qāoa, *neck*).
- adrift* (see *On surface of water*).
- adze*, **H.** tlā'k'oabala (same type as the *Pacific Island adze*); towai'ū (D shaped handle with blade attached to its flat side); tlē'q-kaul.
- afraid*, **N.** ky'ē'tlala; **L.** ky'ē'tlen, *I am—*; **H.** wō'se; wō'senō'gua, or lenō'gua wō'sile, *I am—*.
- to make afraid*, **N.** ts'E'ntiyim; ts'E'ntikya, *to be—*.
- after, behind*, **N.** E'leqtlē; lā'tlin, E'laqtlin, *I will go after him*.
- afternoon*, **H.** tlkyā'qa.
- again*, **N.** hē't'ēt; ē'tēlis, *again in earth*.
- ago, long ago*, **L.** k'aiū'tlutl; **H.** k'aiū'tlutl'ats (—ats, *distant, invisible*).
- agreeable noise*, **H.** aikH'ē'kala (aikH, *good*; —kala, *noise*).
- ahead*, **N.** lalak'a, *to go ahead*; (lak'a, *to pass by, from*; la, *to go*; —k'a, *reaching*); Lā'la-k'ayū'k'oa, *name of female* = *made to go ahead*.
- air*, **H.** nā'la.
- alder*, **N.** tl'ā'k'ōmis (tl'ā'k'ō, *red*; —mis, *tree*); **H. G.** tlā'k'ōtas (from: *red*).
- alive*, **N.** k'o'la; k'o'lasta, *water of life* (—sta, *water*).
- all*, **L.** k'ā'lauē, **N.** nā'qua, **H.** āgy, **G.** wā'qau; *that is all*, **L.** lem-k'ōā'tla, **H.** au k'ōā'tl.
- alone*, **N.** nā'nawa; nā'nawalaqisē'aq'ēnoq, *one who wants to work alone*; **N.** nemō'k' (nem, *one*); NEMō'kuis, *the only one on earth*; NEMō'kynstālis, *the only one who came up out of earth* (—usta, *up*; —lis, *ground*); NEMō'kua, *alone on rock* (—a, *stone, rock*); NEMō'kuak'amē, *all alone on rock* (—k'amē, *superlative*); NEMō'kuitsālis, *alone on prairie* (—itsālis, *flat open country*).
- *to eat, drink, work alone*, **N.** na'qula.
- along*, **N.** —nta(la).
- *long object*, **N.** —nūtsentala (along side of); k'ātsnūtsentāla, *to walk along long object*.
- *flat object*, **N.** —unqentala (—inqē, *edge*); k'ā'senqentāla, *to walk along flat object*; **H.** tōnō'olsa, *to walk along plank*.

always, **N.** —tl; amā'qutatl, *always giving away coppers* (amā'qut, to give away coppers); hā'qk'olatl, *always giving away blankets* (ia'k'ola, to give away blankets); hamā'lagyilatl, *always giving away blankets* (mā'lē, to distribute blankets); —gyilis, *earth, always*; baqbaku'latl, *always eating human flesh* (baqbā'k', eating human flesh, from bek', man).

—**N.** gyilis, *literally: on earth*; hamā'lagyilatl, *always distributing blankets*; winā'lagyilis, *always fighting*; hame'lagyilitlen, *I eat always in house* (ham—, to eat; —itl, in house); hame'lagyilisen, *I eat always on beach* (—is, on beach); Nū'tlk'ala-gyilis, *always acting foolishly*.

among, **N. H. G.** —ak'a; **N.** neq'ak'ā'la, to pull out of a bag; doq'ok'ā'la, to look among —; aih'ak'ā'la, good among others; wā'hak'a, to lead *Hamatsa* around after *Tsētā'ēk'a*; **H.** lē'lt'ak'a, to search among; p'ēpēya'k'a, to feel among; **G.** du'mduk'ak'a, to look everywhere among.

ancestor, **N.** gyāhgyilā'itl = first of house (gyil, first; —itl, house).

anchor stone, **H.** k'alīā'ois (—is, in water); **G.** t'ayaqai'ū.

to anchor; **L.** mō'koanut, cast anchor! (see *To tie*); **H.** tle mē'h'ēnem, to anchor; **G.** t'ayaiā'q, canoe is at anchor.

to angle, **L.** tlā'k'a, k'ē'ta, **H.** t'ōpha'; to drop hook into water, **L.** ts'e'qstenta k'ē'taiō.

angry, **L.** ē'en, **N** tlā'uis; tl'e'tlespis, expert in anger (—pis, expert); **H.** hai'lala (= angry noise; —ala, noise); hailalak's,

angry noise woman (—k's, female).

animal, **H.** sisa'kwimis; a certain —, k'ā'iskatō, large ear (k'ā's, large; —atō, ear).

ankle, **L.** k'oā'tlk'ok', **H.** k'ō'k'anūtl (perhaps: foot side), **G.** k'au'k'ōmatl.

antless, **L. N. H.** wutle'm.

anus, **L.** pō'laqstēe (—qstēe, hind part of body), **H.** amā'kyas.

apron, **L.** tsāp (borrowed from *Common*), **G.** se'paqstēya (—qstēya, hind part of body).

arm, **L. N.** ā'yasō, **H.** haiā'sō, **G.** hā'isō.

—above elbow, **N. H.** ōqsiapē': skin of —, **N.** tl'ētsēapē, **H.** k'uk'uts-ēā'pē.

armor made of wood or skin, **H.** pā'k'aitem.

armpits, **H.** dā'dōk'ola'tsē (—atsē, receptacle).

to arrange bed, **L.** hēitlā'lit; **H.** hailē'tlatl, to make right.

around, **N. H. G.** —istā; **N.** āwī'st around a thing; awistā'lis, hēistā'lis, around the world; lē'istala, to go around; k'ā'tsēstāla, to walk around; maqistā'lisa, making pollatch all around the world (ma'qoa, to give two blankets to each; —lis, earth); **N.** Nūtlemistalitse'mk'a, woman made to go like a fool around the world (nō'lō, nū'tlem, fool; —ista, around; —lis, earth; —tsem, made to; —k'a, woman), **H.** ōē'sta, view; d'ōqsista'la, to look around; tōē'stala, to go around; gy'ēqse'stala, to run around; **G.** k'ā'tsistala, to walk around.

to arrive, **L.** lamen lā'kya, I—; **N.** lē'intih lā'kyaatla, when I arrived.

- arrow*, **L. N. H. W. G.** hā'ntlem; **H.** hā'ntlempa, *arrow point* (—pa, *point*); hā'ntlema'tse, *quiver* (—atsē, *receptacle*).
- bird arrow*, **N.** k'ō'lōk'oiū.
- arrow point*, **H.** k'ē'mkyim.
- to ascend river in canoe*, **H.** sīa'.
- to ascend a mountain*, **N.** lägyustā'la (la, *to go*; —usta, *up*; —la, *v. s.*), **H.** nā'qa.
- to be ashamed*, **L.** mā'qts'a.
- ashes*, **L.** k'onā'i, **H.** gumō'.
- *white of wood*, **L.** k'oa'tlōpes, **H.** k'oa'tlōm.
- *to roast in ashes*, **L.** ā'sa.
- asked by everybody to give feast*, **N.** wutlē't.
- to assemble*, **N.** hōk'onā'kula (—na-kula, *motion*); hōgsta'la, *an assembly (crowd) running into water (?)* (—sta, *water*); kyim-k'onā'kula (*used in songs only*).
- assistant of Hawē'natl*, **N.** nē'qatla, wā'tatla.
- *Hamatsa*, **N.** sā'latlila.
- aunt, father's and mother's sister*, **N.** H. ani's.
- *uncle's wife*, **N.** āpā'tsō (*step-mother*).
- autumn*, **G.** gyā'lemgyilis (—gyilis, *earth*).
- to awake, v. n.*, **L.** ts'ī'nūt, **H.** ts'ihūt.
- *v. a.*, **H.** koia'.
- axe*, **L. N.** sōpai'ū (sōpa, *to hew with axe*; —aiū, *instrument*), **H.** k'ōkuma'kula (k'ō'koa, *to hew with axe*; —nakula, *motion*).
- stone axe for war (long, sharp stone fastened in a perforated handle)*, **N.** neb'ai'ū.
- B.
- baby*, **N.** wī'sa, **H.** qenū'q'ō, **G.** qābq (*from qap'ē', cradle (?)*).
- back*, **N.** —ikyē, —igya, **H. G.** —ēgya; **N.** awī'kyē, *back*; k'ō'k'ō-igya, *hunchbacked*; ts'it'kigyila, *feathers on back* (—la, *v. s.*); mōē'gyint, *to carry on back*; penē'gyalil, *to warm one's back*; nā'lagyiligya, *back of day of world* (—gyil—, *earth*); **H.** ōsk'amē'gya, *back* (—sk'am, *outside of round thing*); ts'ē'm-tōgya, *dorsal fin*; k'u'tsemē'gya, *skin of back*; ōwē'gyatlkyā'nē, *back of hand* (—tkyā'nē, —skyā'nē, *hand*); k'u'tstsc'gyatlkyā'nē, *skin of bark of hand*; ōwī'gyatlsc'tsē, *instep* (—(t)tsētsē, *foot*).
- *support (lazy seat)*, **N.** yi'mk'oas (—as, *place*).
- bad*, **L. N.** ia'qsum (i—, *negation*; —aii, *good*), **H.** iaki, **G.** iai; **N.** ia'qp'aqsta, *to speak bad of one* (—qsta, *mouth*); **G.** iakhe-k'ala, *bad noise* (—k'ala, *noise*).
- bad tempered*, **H.** thsa'la (—ala, *noise*).
- baileer*, **H.** qa'lygilis.
- bald headed* (see *Bare*).
- ba'qus* (*season when no Tsōtsā'ōk'a must be held*), **N.** ba'qus.
- bare*, **H.** t'ōk'; t'ōk'k'ea', *bare headed* (—k'ea, *head*); t'ōk'u's, *country bare of plants* (—us, *outside*); t'ōqse'mla, *bare mountain* (—k'sem, *outside of round thing*; —la, *v. s.*).
- bark of tree*, **L.** qā'k'um, **H.** qk'um.
- *of cedar*, **N. Tl. H. W. G.** tena's, **H.** dā'deotl (?).
- to bark*, **L. N.** wō'koa, **H.** wā'kya; **L.** wō'kōq ta wa'tsē, *the dog barks*; **N.** wā'wakulitla, *barking in house* (—itl, *in house*).
- barnacle*, **L. N.** qā'ik'.
- basket*, **L.** leqā'; **N.** Leqlā'q (*a name*), *basket eater* (?).

basket, small, for fish, **N.** lā'laqam.

— *large, for blankets*, **L.** tlā'pat, **H.** ku'ē'patsē (—atsē, *receptacle*).

— *for fish and clams*, **H. G.** ts'ela'.

— *for berries*, **H. W.** nanā'k'em (nāk'a, *to drink, the basket is watertight*).

— **L.** pē'kyoo.

bat, bak'oalā'uē, making sleepy, from bā'k'oatlēla, sleepy.

baton, used in winter dance, **L. N.** t'a'miaiō, **H. W.** tlē'qem; **N.** t'a'msala, *to beat time* (—ala, *noise of (?)*; —sila, *to make (?)*); t'ā'miatsē, *master of batons*; t'a'miasilāla, *rhythm*; **H.** tlē'qala, *to beat time*.

baton, **H.** hauā'qala (—ala, *noise*).

— *of chief*, **tl.** sik'a'kyanō, **H.** sī'kyak'em.

bay, **L.** awētlē'sela, **N.** ō'jtllalis (*perhaps only head of bay*), **H.** ōtsoi's.

beach, **N. L.** —is, —lis; **H. G.** —is, —lis; **L.** tlē'māis, *beach*; t'ā'tis, *lying on beach*; **N.** ōk'omā'lis, *face of beach* (—k'am, *facing*); d'apā'lis, *covered by tide* (d'apa, *to flood*); ha'lqsualis, *killing on beach at mouth of river* (—sinaē, *river mouth*); **H.** ūwi's, *beach*; ai'kyitskolis, *flat beach* (āikh, *good*); hana'qtis gyi'loaq, *canoe is on beach* (han—, *hollow object, canoe*); **G.** wō'qanuis, *beach*; goā'is, *to sit on beach*; aigyitsui's, *flat beach* (āikh, *good*).

heavy beams supporting roof, parallel to ridge of house, **L.** ky'ā'tēwan, **H.** k'aqā'wa.

grizzly bear, **N. L. tl.** **H.** nān; **N.** gyi'la; **G.** sān; **N.** Nuqnēm̄is name: nē'nēnk'as (= *bear woman*); nanis, *bear in bottom of*

sea (—is, *in sea*); nanqa, *called bear* (—qa, *eulled*); na'ntsē, *great bear* (—tsē, *great*); na'n-k'amā'lis, *bear facing beach or earth* (—k'am, *facing*; —lis, *beach*); na'nqtlō, *cinnamon bear*.

skin of grizzly bear, pas'ena'ē.

black bear, **L.** tlē, **N.** tlā'ē, **H.** tl'a, **G.** t'ē'noa; **N.** Nuqnēm̄is name: tl'ē'tlēk'a, *bear woman*.

beard, chin, **L.** hapa'qstēya (hap—, *hair*; —qstē, *mouth*), **H.** hā'p-ensia' (hap—, *hair*; —ensia, *tooth*).

— *moustache*, **L.** hapa'qstēya, **H.** hāpqtā'ē (—qtaē, *mouth*), **G.** hapēqtē (—qtē, *mouth*).

to beat time, **N.** t'a'msela (see *Baton*).

— *on beach at marriage ceremony*, **N.** ts'ā'qa.

beaver, **L. N.** ts'ā'ōē, **tl.** ts'ō'k'oa, ts'ā'ō, **H. G.** kolō'n (*borrowed from Bilqula*); **H. L. N.** ts'ā'e-atsē, *young beaver* (—atsē, *young of —*); **N.** Nuqnēm̄is names: d'akyā'lis, hē'lumutasōla.

bed, **L.** k'ē'nutl, **H.** k'oi', **G.** ku'l'ilas (ku'l'itl, *to sleep*; —as, *place of*).

bedroom, **N.** gyū'las, **H.** k'wē.

to beg, **N.** k'ōē'k'oasa; k'ōē'k'oasalatl, *beggar dance*.

behind, **N.** ōqtlē'ē; **L.** ōqtlak-ī'tsē, *heels*; alqtlac'istala, *coming around last*; **H.** —qtlē; wala'q-tlēk's, *youngest daughter*; d'ōk'ōqtlā'la, *to look back*; goa'qtlē, *to sit on hind part*; kōpaqtlā'ut, *to break off hind part*; **G.** d'ō'k'ōqtlā, *to look back*; hā'nts'-aqtlē, *rest of foot*.

to believe, **N.** nē'nky'ek'ala.

Bellabella village, **H.** G'alts.

Bella Coola, **N. K. H.** Bī'qula.

- belly*, **L.** tā'ikyē, **H.** tky'č, **G.** tēku ; **H.** k'utsēqtlā'ēs, *skin of* — ; tlē'qoaqtlāli'sēla, *sick in* — .
- below*, **N.** pē'n'a, **H.** ōa'poa, ēsa'poa ; **G.** āu'apōa, **H.** hēsā'po-itl, *below in house* ; wīwunk'apo-is, *bottom of sea* (—wunk', *edge* ; —apoa, *below* ; —is, *in sea*) (see *Under*).
- below (down river)*, **N.** gua'ē (also *north*), gua'tsē.
- belt of women*, **L.** wusī'kyanem, **H.** wāu.
- to bend with hammer*, **H.** mōkpta'ut (mōkoa', *to strike with hammer*).
- berries (species unknown)*, **TI.** haītlus ; k'ē'qēlis ; k'ēmko'alē' ; k'ē'sk'ēlē'q ; k'ōā'k'ugē'e ; k'ō'q-k'uls ; nek'utl ; sī'lem ; waopa'litse ; tlē'k'um ; tliq ; **L.** ts'ē'nina ; tsī'k'etl.
- black berries*, **H.** ciā'k'unatl.
- cranberries*, **L.** tū'stak'a, **TI.** tū'stik'ua.
- hackleberries*, **L.** k'ōā'tem, **H.** koā'tem ; **L.** k'ōā'tlmis, — *bush* ; k'ōā'tqut, *eating* — .
- salmonberries*, **L.** k'ē'ntsuk ; **A. H.** kau'lali ; **H.** kau'tlila, *country full of berries*.
- sallaberries*, **N.** nēqnā'k', *eating* — .
- soapberries*, **N. TI.** nēquski'n ; **H.** nuqsku, *berry soup*.
- dried berries*, **L.** t'č'ka, **H.** lek'k.
- to bewitch by putting clothing of a person in contact with a corpse*, **N.** lā'pētantē, lā'pētanū.
- *by putting clothing in a skull which is heated*, **N.** ē'k'a ; *person who knows to do so*, ē'k'ē-noq.
- *to counteract the ēk'a, by repeating the process*, **N.** de'gyinta ; de'gyinteēnoq, *person who knows to perform this act*.
- bile*, **H.** k'u'lumas.
- bill of bird*, **H.** ū'tlpa (—itlpa, *nose*).
- bird*, **L.** ts'ek, **H.** ts'ē'kō, **G.** ts'ek'. — *hammering bird*, **N.** k'wā'kumtē. — *meadow lark (Sturnella magna, neglecta)*, tlē'tsēn, **N.** ōtseq-tāla. — *warbler*, **N.** mā'mēma. — *Oregon junco (Junco hyemalis)*, **N.** tsō'pamalē. — *Ampelis garrulus*, **N.** kyaā'kyētaqtlē. — *violet green scallow (Tachycineta thalassina)*, **N.** mā'matlēkya (mā'tlē, *to fly, flying around in short cuts*). — *Ammodramus sandwichensis*, **N.** k'ē'qēgyila. — *chickadee (Parus rufescens)*, **N.** tsōtsā'k'a. — *thrush (Hesperocichla uæia)*, **N.** tsōp'alē. — *Merula migratoria propinqua*, **N.** k'ak'alā's. — *Zonotrichia cornata*, **N.** tses-k'ōā'nē. — *snipe*, **N.** t-ā'tsatkyaawa. — *Bubo virginianus*, **N.** te'itēnialētl, **H.** tuūmī. — *Nyctea*, **N.** ky'ā'sāqa. — *Nyctala acadica*, **N.** bekue' (soul, ghost). — *screech owl (Megascops asio Kennicottii)*, **N.** uōpūōp, kyō'kyōkyō. — *licker (Colaptes caper saturator)*, **N.** gu'item. — *woodpecker (all kinds)*, **N.** tlā'tlanaētl. — *kingfisher (Ceryle alouon)*, **N.** kyetelā'wē. — *Corvus caurinus*, **N.** kyiqēlā'k'a ; *Nuguēmis name* : ky'ā'nauōk'a ; **TI.** ts'eqsā'k'ē ; *Nuguēmis name* : kīrk'alā'k'a ; **H.** kī'ā'k'a.

- bird, blue jay, **N.** ku'ckuc.
 — hawk (various kinds), **N.** mā'-
 manē.
 — eagle, bald and golden, **N.**
 kuē'k', **H.** wīk', **G.** aiusto-
 k'oē'oa.
 — Swainson's hawk (*Buteo Swain-
 soni*), **N.** l'ōt'ā'lōtl.
 — red-tailed hawk (*Buteo borealis
 calurus*), **N.** ā'ukganē.
 — fish hawk (*Pandion haliaetus,
 carolinensis*), **N.** ts'ēhts'ēk.
 — sandpiper (*Creunetes occiden-
 talis*), **N.** ts'esqanē'k' .
 — *Tringa alpina*, **N.** tsō'p'apa'lā.
 — plover (*Charadrius squatarola*),
N. tsō'tsetsa.
 — *Aegialitis semipalmata*, **N.**
 k'a'l'ia.
 — *Limosa fedra*, **N.** k'oā'k'oa-
 k'um.
 — pintail (*Dafila acuta*), **N.** wē'-
 wapēs (—wap, water; —pēs,
 expert=liking fresh water).
 — petrel (*Oceanodroma furcata*),
N. k'oē'k'oēk'oē.
 — gull, **L.** ts'ā'ek'oaam, **N.** ts'ē'-
 k'oa, **H.** ts'ē'kyēla'k'a; **N.**
Nuqnēmīs name: **N.** mā'tagyla
 (making fly (?)), tsē'nqk'aiō.
 — *Diomedea albatrus*, **N.** bā'tla.
 — tern (*Sterna paradisæa*), **N.**
 k'ā'k'akyitawa, biting off from
 man's head; k'ā'gyuk', a piece
 bitten off.
 — *Merganser serrator*, **N.** k'ōk'ō'-
 os; *Nuqnēmīs* name: k'ōk'ō'-
 ts'aqsmā'lak'a (as mīnk's wife);
 tlē'mk'ēu (=gummy head).
 — coot (*Oidemā perspicillata*),
 lēk'ā'p'āla.
 — scaup duck (*Aythya marila
 nearctica*), **N.** tsō'ts'espēs.
 — loon (*Urinator Imber*), **N.** qā'-
 wē.
- bird, Holboell's grebe, **N.** hā'masilalis;
Nuqnēmīs name: hā'maqsta.
 — horned grebe (*Colymbus aurī-
 tus*), **N.** k'ā'u'tak.
 — *Brachyramphus marmoratus*,
N. tegyē'gyila.
 — *Urū Grylle Californensis*, **N.**
 l'Enq.
 — cormorant (*Phalacrocorax pel-
 agicus resplendens*), **N.** lā'qlaq.
 — — (*Phalacrocorax pelagicus
 robustus*), **N.** tlō'panē; **tl.** tlō'-
 patl.
 — *Cepphus Columba*, **N.** tsē'ssa.
 — gray-ruffed grouse (*Bombosa
 umbellus umbelloides*), **N.** ku-
 ku'mq'a.
 — *Dendragapus obscurus fuligi-
 nosus*), **N.** hō'mbōm.
 — pigeon (*Columba fasciata*), **N.**
 hamō'.
 — sandhill crane (*Grus mexicana*),
N. atē'mkulē.
 — blue heron (*Ardea herodias*),
N. k'oā'k'oānē.
 — oyster catcher (*Hamatopus
 bachmani*), **N.** guē'guēguē.
 — swan (*Olor columbianus*), **N.**
 k'ak'ā'uk'.
 — snow goose (*Chen hyperborea*).
N. tl'ē'staq.
 — *Anser albifrons Gambeli*, **N.**
 ne'lla.
 — *Branta nigricans*, **N.** nā'naqā-
 kem.
 — *Branta Canadensis*, **N.** neqā'k'.
 — pelican, **N.** hā'uqaukoā'yatl.
 — *Charitonetta albeola* (male), **N.**
 tl'aā'tlē.
 — *Charitonetta albeola* (female),
N. hū'pē.
 — Mallard duck (*Anas boschas*),
N. tlā'tlky'ēū.
 — *Clangula hyemalis*, **N.** hahā'nē.
 — harlequin duck, **N.** mā'tsēna.

bird, golden eye (Glauconetta clangula Americana), **N.** kutē'na.
 — *Spatula clypeata*, **N.** sisōk'na.
 — *Oidemia Deglandi*, **N.** nōqnp-stā'la, **TL.** k'āmtsē'q.
 — *Urotrichus Gibsii*, **N.** gyā'gy'-apes; *Nuquēmis name*: hāla-mā'lak'a.
 — (*species unknown*) **TL.** tlē'stlēk': tlā'tsem; mā'tsēnē; ky'ī'nōt, **H.** kūi'nk'; nēsna'k'.
 — *fabulous birds*, **N.** hā'utlak'anus; mā'kōkyū, *said to make canoes in woods*.
to give birth to, **L.** mā'yōtlam, **H.** mā'yōtla.
biscuit, **N.** kwā'k'uqsem; kwā'k'uq, *eating* —.
to bite, a piece bitten out, **N.** k'a gyuk' (k'amgyuk' (?)).
black, **L.** ts'ō'tla, **H.** ts'ō'tla, **G.** ts'u'thō.
bladder, **H.** te'qatsē (—atsē, *receptacle*)
 — *of fish*, **H.** wulē'tl.
blankets, all kinds of, when used, **L.** ne'q'unē, **H.** k'ō'tih, **G.** tsat-sāg'ō'ōtl, **H.** —ōtl; **N.** alā'gyim, *skin* —; tlē'k'oqsem, *martin* — (tlē'k'ek', *martin*); pelpe-lask'e'm, *mountain goat wool* — (p'ā'lem, *wool of mountain goat*); k'ā'sasqem, *sea otter* — (k'ā'sa, *sea otter*); tlō'qsem, *red* — (tlāk'oa, *red*); k'ō'tsem, *black* — (*the ending common to these words is probably* —k'sem, —sem, —k'em, *related to*: *outside of round object, in reference to their being put around the body*); k'utá'otl, *skin* — (**H.** k'utse, *skin*; **H.** —ōtl, *blanket*); gy'ō'paoas, *blanket made of yellow cedar bark*; yā'k'ēlak, *another style of the same*. **H.** mā'ms-tlk'ōtl, *martin* — (mestlk'an,

martin): ts'atsaqkō'tl, *mountain goat wool* — (ts'ak', *mountain goat*); k'ak'ā'sōtl, *sea otter* — (k'asa, *sea otter*); te'qsem, *green* —; tlā'ōqstō, *red* — (tlāk'oa, *red*); kye'lqsem, *white* —; ā'mesem, *black* —; tsatsoa'la, *skin* — *for children*; yiqtu'mkena, *Chilcat* — (yiq—, *dance*).

blankets, lying about, **L.** k'uī'lk'nēla, **H.** mā'mētl.

— *in pollutch*, **N.** iō'k'ala.

— *tied around belly*, **L.** sā'qstaō (—qsta, *end of body*), **H.** sap'ā'qstēgyila (—qsta, *end of body*; —gyila, *to make*).

— *to put on blanket*, **L.** k'ō'qotlsut (—ōtl, *out of* (?)).

— *to take off blanket*, **L.** k'ō'qtsut (—tsoā, *in* (?)).

blind, **L.** p'ā'p'as, **H.** b'āk'.

block by means of which Huiē'na'at is raised, **N.** k'ā'k'čūyī.

blood, **L.** Elk, **N.** a'lg'um, **G.** be'lu'tem; **H.** a'lkoasa, *blood in body*; a'lūsimala, *blood on outside of something* (—sem, *outside of round object*; —la, *v. s.*); a'lhokyanā'la, *blood on hand* (skyāna, *hand*).

to bleed, **L.** a'lu'uit, **H.** a'lkoa; **H.** a'lkuītlpa, *nose bleeds* (—itlpa, *nose*); a'lkmāla, *face bleeds* (—ma, *face*; —la, *v. s.*); aqa'lkus *blood on ground* (—us, *ground, outside, country*).

to blow fire, **L.** pū'quit.

to blow, wcale, **N.** tlā'tla; Tlā'tlac-gyilis (*name of a woman*), *blowing on land* (—gyilis, *land*).

blue, **TL.** tsā'ca, **H.** koā'yēlak's, **G.** koilā'qstō.

board, made by means of wedges, **H.** hā'was (*also board of roof*).

— *sawed*, **H.** kēqk' (kēqa, *to saw*).

- body*, **N.** ō'gwinē, **H.** ōkōna' (*only surface of body*); **H.** k'EMEQā'otlna, *left side*; hai'tlkoitlna, *right side*; tlōqoana'la, *sick, sore all over*.
- body, corpse*, **H.** k'a'lkuis; k'a'lkūē, *drifting* (—ē, *on surface of water*); k'a'lkuntsis (—unts, (?); —is, *in sea*).
- to boil, v. n.*, **L.** tlema', **H.** tlema', tlōō'm.
- to bolt*, **N.** ts'ē'mk'oa.
- bone*, **L. W. G.** qāk; **L.** hāk'ō'poi, *sternum* (—pōē, *breast*); **H.** ts'īō'poa, *sternum* (—poa, *breast*); k'ō'tsaqā'oa, *collarbone* (—qāoa, *neck*).
- *of fish*, **L.** k'ō'k'oiāō.
- boom (of canoe sail)*, **L.** tsē'kyinū'tlemē (—nū'tlemē, *side of*), **N.** tsī'kyanqai'.
- born (perhaps: from beginning)*, **N.** nū'tlamō, *born a fool* (nū'tlem, *fool*); nō'k'amō, *born wise*, (nō'k'at, *wise*).
- both*, **N.H.** waqs; **N.** waqse'nqē, *both sides* (—ENqē, *edge*); wa'qsen-gilis, *somebody on each side of an object on beach*; waqsemk'a'sela, *to put into mouth from both sides*; waqsistaut, *to divide*; **H.** waqsōde'toa, *both ears* (—Etoa, *ear*).
- bottle made of kelp, kelp*, **L. N. H.** wā'watē.
- bottom of an object*, **N.** ō'qstē, —qste; **L.** pō'laqstē, *anus*; sā'qstaē, *blanket tied around belly*; **H.** —stē (?); kyā'qtē, *notch of arrow* (= *notch in bottom*); sap'ā'qstē-gyila, *blanket tied around belly*.
- bottom of sea*, **N.** k'ā'tsī's (—is, *in water*), **H.** wīwu'nk'āpois, (—unk', *edge*; —apoa, *under*; —is, *in water*).
- bow*, **L. N.** tlā'kuis, **H. G.** tle'kuis. *bowstring*, **H.** tlkūē'tsem.
- bow of canoe*, **H.** tlē'tskina.
- *man in bow of canoe*, **N.** ō'kyinē.
- box, Indian*, **L.** QE'tSEM (*borrowed from* ʕatłōltg), **L. N. H.** gyī'ltas.
- box for blankets*, **H.** pāk ēye'la, **G.** ɭāk'ea'la.
- — *grease*, **H.** tenguā'tsē (—atsē, *receptacle*).
- — *blankets*, **H.** ky'ē'lqsema'tsē (= *white blanket receptacle*).
- *woman's working box*, **H.** ōkwal-ā'tsē (—ātsē, *receptacle*).
- *for berries*, **A.** k'atlk'.
- boy*, **L. N.** gyinā'num (*child*), **H.** gāpqō' (*about twelve years old*).
- bracelet of mountain goat horn*, **N.** yē'k-wēkila, **L.** gy'ō'kula.
- bracelet of copper*, **TL.** k'ōō'k'ōē, **H.** ts'EWā'ta.
- braid*, **L.** haē'qstō, **L.** k'ā'tlēc.
- brain*, **L.** tle'k'oa, **H.** tlqk'ōā'tsoa.
- branch*, **L.** wū'tlā'nē, **H.** tl'ESna'.
- to break, L.* kyū'q'uit (*see To fight*), **N.** kyō'k'oa; kyō'qkyōk'oa'la, *noise of breaking* (—ala, *noise*); **H.** kōu'mesiūt; kō'kumsia, *to break to pieces (reduplicated)*; kōkoapoa'lut, *to break by bending*; kōpaqlā'ut, — *off hind part* (—qtlāē, *hind part*); kōō'upaūt, — *off point*.
- *with hammer*, **H.** mu'qsiut, — *with one stroke*; mumu'qsia, *with many strokes*.
- *coppers in potlatch*, **N.** laqs'E'nt; ɭā'laqs'E'nt'aiō, *means of breaking copper (a name)*.
- *I break it*, **N.** t'ap'ētēn.
- breaker for cedar bark*, **L.** kyā'ts'aiō, **A.** yītsai'ō, **H.** tlāna'kula (—nakula, *motion*) (*shape of the tapa beaters*), tss'oi'ō (*shape somewhat like a mincing knife without handle*).

breakers, **H.** kwē'ta.

breast, **L. N.** ōpō'ē, —pōē; **L.** hāk'-ō'pōē, *breast bone*; **L.** nak'pō'ē, *stomach*; **N.** tlē'tsepō'ē, *skin of* —; **H.** tūk'āpoa', —poa; ts'i-ō'poa, *breast bone*; k'utsepō'a, *skin of* —; tlōqoapō'ala, *sick on* — (tlōqoala'sō, *sick in* —); **G.** tak'apō'a

breast, female, **L.** ts'ām, **H.** tsaa'm, **G.** dzām (see *To suck*).

breath, **N.** hā'asaē, **H.** hā'spiō; hā'sōt, *to breathe out*.

bride, **H.** qaē'tl.

to bring back novice from woods by dancing, **N.** wutlā'qut.

broom, **H.** ky'alai'ō.

brother (*said by male*), **N.** ne'mwīut; collectively: ne'ne'mwīutlāla, *brothers and male cousins*; nā-tlemwī'ut, *relatives*; **H.** menū'ya; **G.** menō'suwa.

— *said by female*, **N. H.** wā'k'oa.

— *younger*, **L. N. H. G.** ts'ā'ya; also: parent's younger brother's or sister's child.

— *younger, addressed*, **N.** wis.

— *elder*, **N. H. G.** nō'la; also: parent's elder brother's or sister's child.

— *elder, addressed*, **N.** gyi'E (see *Chief*).

brother-in-law (both kinds), **N.** k'olis, gyi'mp; **H.** also: *sister-in-law*.

brush, **H.** ky'ā'taiō (= *paint instrument*).

bucket, **L.** nā'k'atsē (= *drink receptacle*), **H.** nā'k'em (from nāk'a, *to drink*).

buttocks, **H.** me'nkyatse.

to buy, **L.** kni'hoa, **H. G.** tlēa'; **H.** tlēa'nuq, *something that has been bought*; tlēi'lks, *storekeeper* (= *expert in buying*); tlēaē'les, *store* (= *buying house*); **G.**

tl'ēla's, *store*; tl'ē'lgis, *store-keeper*.

by and by, **L.** k'oatlemā'stl.

C.

calf of leg, **H.** tl'ē'tl'ēkya (—ēkya, *leg below knee*).

to call, **L.** lā'k'oalasō; lamanqt lā'k'oa gyā'tlk'ē, *I call again*.

to call to feast, to invite, **N.** g'ē'la; tlallig ēlā'lait, *every one calls him to feast*.

called, to call, **N.** —qa; quā'kunaqan, *I call canoe, i. e., I wish to buy a canoe* (quā'k'un, *canoe*); nānqa, *called bear*.

calm, **H.** k'auqk'ula; k'au'k'o-is, *place where it is always calm*.

to camp, **N.** lēk'u'la; lā'k'u'ilila, *tribe always camping about*.

canoe, **L. N.** quā'k'un; quā'kunatl, *canoe that is going to be, i. e., that is making*; quā'qukunatsē, *large canoes*; quakunamēn'q, *small canoes*; quā'kunatses, *fragments of canoe*; quā'quakuiala, *to look for a canoe wanting to buy it*; quā'kunaqan, *I call a canoe, i. e., wish to buy it*; **N.** gyā'lō (*obsolete*), **H.** gyi'l'oa, **G.** gyi'l'oa; **H.** gyil'oaai'asē, *place of canoe in woods*; gyi'l'okō'tlē, *broken canoe*; **N.** guī'tes, ku'mtsala (?).

— *Chinook canoe*, **L.** se'qem, **H.** sqam.

— *war canoe*, **N.** d'aku'n.

— *large war canoe*, **N.** me'nk'a.

— *Fort Rupert canoe*, **L.** quē'taq'tla.

— *Haida canoe*, **H.** hai'dats.

— (*what kind?*), **L.** yā'atsē.

— *legendary (folding)*, **N.** dā'tldat'ta.

— *in canoe*, **N.** ō'qse; laqs, *to go*

into canoe (la--, to go); gyā'-qaqsala, to come in canoe; gua'-qsela, to sit in --; mō'qsela, to load --: **H.** lōpqs, empty canoe (lōp, empty); laqsut, to load canoe (la--, to go: --ut, v. a); goa'qs, to sit in --; **G.** laqs, to go into --; wā'meqsūt, to load --; goa'qsala, to sit in --.

— lying on side, **N.** k'ōk'ōatla; k'ōk'ōmā'lis, canoe lying on side in front of beach.

— drift, **H.** k'auk'ōansela'k'tlē (—tlē, on surface of sea).

— han--; this stem probably means a hollow vessel (see Kettle), and is used in composition with local suffixes; **N.** ha'nk'amlis, canoe landing in front of beach (—k'am, in face of: --lis, beach); hanhsī'waē, canoe at mouth of river (—siwaē, river mouth); hanuē'lagyitlē, canoe is on water; **H.** hana'qtis (gyi'loaq), canoe is on beach; hanā'eas gyi'loaq, canoe is on water; hanā'laktla, canoe at anchor; hanēā'sēs gyi'loa, place of canoes in forest; **G.** hanēilwā'paqt, canoe is on water.

— place of -- in forest, **H.** tlq'ēā'sē.

out of canoe, --otlt; **N.** gyaqotltā'lisuisus, he brought one out of canoe to beach; **G.** wā'mōtltut, to unload.

to make canoe, **H.** ā'tl'a; ā'tl'eskīō, canoe builder.

cap, dancing --, **N.** ts'ē'qēōē (ts'ēk'--, secrets, winter dance; --ēōē--, forehead).

capable of --, **N.** ts'ēs; d'ō'qis'ēs, seer; **H.** --tes; k'ā'wates, with good power of hearing.

cape, **N.** wāqsā, **H.** ōa'qsiwa.

to capsize, **L.** k'apā', **H.** k'pacē';

k'pē'tla, something turned upside down; k'pē'tla-itl, something turned upside down on floor.

to take care of --, **N.** aā'qsila; tlā'-tlaqsila, taking care of cedar-bark rings (tlā'k'ok', cedar-bark ornament); mā'menatsila, taking care of drums (?) (menā'tsē, drum; --ila, to make; probably drum maker).

to treat carefully, cautiously, **N.** mā'-yanila.

something one does not care for, one does not want to keep, **N.** wā'iat (w--, negation).

cariboo, **H.** tl'aqt.

to carry in hand, **N.** dā'la, --enk'ula, māsemenk'olawis, always carrying two round ones in hand; mamō'sk'amenk'ola, carrying four round ones in hand.

to carry into house, **H.** laai'tla (la--, to go; --itl, in house).

to carry on back, **N.** mōē'gyint (—igya, back).

to carry load into canoe, **L.** mā'wa (see To load).

carrying something in mouth, **N.** tē'kuqsta (—qsta, mouth); k'ē'tyeqstils, -- outside (see To bite, --qsta, mouth; --ils, outside); k'ētyeqstā'litl, -- in house.

to carry fire, **H.** pē'n'it (?).

to carve meat, **L.** k'ā'qit; k'ōā'tlaiō, carving knife.

carved figure, **N.** ky'ēk'.

carving knife, **L.** k'il'uatlam, k'ōā'tlaiō, **H.** ky'ē'olem.

cat, **L.** mā'matlis (see European), **H.** mā'qoa.

cataract, **L.** tsē'qoaqala (—aqa, down), **H.** gy'ā'matsen.

cat's cradle (game), **N.** ts'etltsē'nu.

to catch salmon in net, **A.** tlakil, **H.** k'ō'koayōt.

cause of —, —im; ia'kuim, cause of evil; ē'ikuim, cause of good; alē'tsim, cause of being firm.

cedar, **L.** tēnā'smis (te'nas, cedar bark; —mis, tree), **A.** te'nies, **H.** dē'was, **G.** koaqtā'.

cedar bark ornament for winter dance, **N. H.** tl'ā'k'ōt (tlā'k'oa, red = made red).

chair, **H.** goā'utema (goa—, to sit).

cheek, **N.** āu'tsē, **L.** ō'nutlemē (—nutl, side of; —mē, face), **H.** ōwa'mia (—mia, face); **N.** t'ēkyu's, mythical name of deer = strike face.

to chew, **L.** mā'lekula, **H.** k'askyā'la (gum and food = noise of chewing), au'akō (tobacco).

chips, k'ōk'oakā'oa (k'ōk'oa, to heat; —āoa, refuse).

chief, **N. L.** gyī'k'amē (gyī, elder brother, chief; —k'amē, superlative); gyē'qsem, group of chiefs; **N.** hē'meskyas, real chief (name of raven; —kyas, real); **A. H.** hēma's, coll. hē'mas, **G.** hai'mas.

chieftainess, chief's wife who gave her husband at time of marriage much valuable property, **N.** ō'ma; ō'magyila, to make —; ō'mak'asemaē, chieftainess in face of all; ōmaqtā'latlē, chieftainess on sea (?).

chief's wife who did not give her husband much property, **N.** mō'tsitl (= keeping blankets from floor).

chief's eldest son, **N.** tlēō'tek'amē.

chief's daughter, **N.** ky'ē'itl.

child, **N. L.** qōnū'k', col. gyī'ngyīnam, **H.** qōnū'k', col. s'ā'sem, **G.** qōnū'q.

— eldest, **L.** nō'lasnek'emā'ē (nō'-

la, elder brother; —k'amaē, superlative), **H.** nōla'k'amē.

— second, **L.** k'ā'yāē, **H.** qankē's.

— third, **N.** g'au'i, **H.** g'auioaqtlē (—qtlē, behind).

— youngest, **L.** tsa'inqē (tsa'ēa, younger brother; —inqē, edge of), a'ma-inqē (ama—, small); **H.** wāla'qtlē, youngest son (—qtlē, hind); wala'qtlēk's, youngest daughter (—k's, female).

parents with children, **N.** gyinlī'kyelē.

chin, **L.** pē'nkyutaqstē (pēn, below; —kyut, opposite; —qstē, mouth), **H.** k'ō'a'u, **G.** gy'uq.

chisel, **L.** ky'ī'mtāiō.

to chop, **L. N.** sō'pa; **N.** sō'ps'al, to chop in half in house; sōps'a'lsa, — on beach; sōps'ali'sa, to chop log on beach in half; sō'pē-tl'anē, to chop in many places; sō'paiō, adze = chopping instrument; **H.** k'ō'koa; k'ō'konakula, adze; k'ōk'oakā'oa, chips.

clams, **L.** kyā'ōēk'anem; large —, mat'ā'nē; **N.** clamshell, gyō'gwis; **H.** clam, ts'ē'koa; large —, tsēma'nē.

a clean house, **N.** ku'muelalitl (—itl, floor).

to climb a tree, **N.** tl'ēpa'; — a mountain, tl'ēpustā'la (—ustā, up; —la, v. s.).

cloud, **L. H.** anū'ē; **N.** a'nk'ōla, cloudy; A'nk'ōlayūk'oa, female making cloudy weather; a'nk'ōalagyilis, country always cloudy.

clover root, **N.** tliqē; tliq-ī'wāē, — at mouth of river.

club, fish —, **L.** t'ē'lusqān, **H.** hō'tl'em.

— war —, **N.** kuē'qaiō; to strike with —, kuē'qa.

coal, **L.** ts'ō'tlā, **H.** ts'ō'tla.

- coat, European*, **L.** kipō' (Chinook), **N.** dā'datsowāk', **H.** d'ā'datsoa.
— *old style*, **N.** t'Epē'tsāē.
- cod, red*, **L.** tlā'tlaqon (tlā'k'oa, red), **N.** nē'ts'ē, **H.** tlā'k'o-itk.
- cod, black*, **TI.** t'ē'ha, **H.** hā'tanē.
- cod*, **TI.** **H.** nā'tlēm, **L.** kyū'mak' (borrowed from Çutlōltq).
— *sp. (?)*, **H.** sītqta'la (—qta, mouth).
- cold*, **L.** wu'ta, **H.** t'Enē'k', **G.** t'Enē'q; **H.** kh'enē's, to feel cold.
- collarbone*, **H.** k'ōtsaqā'oa (—qā'oa, neck).
- column, heraldic*, **N.** mo'qpik' (mo'q—, to tie; —pik', pole; because blankets are tied to it); **TI.** **H.** ts'ōā'qse (—qse, outside).
- column, memorial*, **H.** ālaqtE'n.
- comb*, **L.** qa'k'em, **H.** gy'i'ngyanētl.
- to comb*, **L.** qā'k'a-it, **H.** gy'i'ngya.
- to come*, **N.** gyaq; gyaq'ōltsoa, to come out of; ōmen gyaqwulī'tla, I come unasked; k'anlō gyaqa'la, when I come back (obsolete); k'anlō gyaqē'tlētō, when I come back; alqtlāē'istala, coming around last (—qta, last; —ēista, around); **H.** nōgua ā'k'ēla, I come here.
- common man*, **TI.** **H.** qā'mala.
- company, group*, **H.** k'atē'tl, col. k'atk'atē'tl, **N.** —qsem, gyē'qsem, group of chiefs
- companion of Hamats'a*, **N.** sâ'latlila.
- to conquer*, **H.** ai'khoa; **L.** lamēn ai'khaumasē, I — thee.
- constellations*, **A.** kyai'utla, **A.** ali'qua.
- to cook*, **L.** metE'lquit, **H.** a'mgyila.
- copperplate*, **L.** **N.** **A.** tlā'k'oa (= red); tlā'tlaqsem, small copperplates tied together (—qsem, group of —).
- copperplate, woman for whom father plants copperplates in ground*, **N.** sēpā'alētlilaok'.
- corner*, **H.** ōā'toa, p'esaai'; **N.** gcā'nē, to sit in corner.
- to cough*, **L.** lēqā', **H.** lēqoa'.
- council*, **N.** k'uē'qala (—ala, noise); kuā'kunqs'ala, to council; **H.** hāsqa'la (—qta, mouth).
- councillor*, **N.** k'uē'qtās; kuē'qalagylis, councillor of his own country.
- to count*, **N.** hō'sa; Hōstā'lakyimō, people counting objects thrown into water (?) (—sta, water).
- country*, **L.** t'E'kya, **H.** tsqams (= dirt), —is; **N.** wī'nakuis, country; ōtsā'lis, flat country, prairie; k'ā'lōkwis, crooked country; Gyinginā'mis, children of earth = dwarfs; —gyilis.
- , — us (see Outside), **H.** —us; t'ō'k'us, country bare of plants; aq'ā'lkus, blood on ground; k'an'k'ois, place where it is always calm; —ila, —gyila, probably originally no local meaning (see To make); k'a'mtlila, country where deer are found; waā'nēgyila, — where herring are found; ts'ā'k'gyila, — where mountain goat are found (the meaning is probably: catching deer, herring, etc.); —ēnoq, iukuē'noq, windy place = knowing to blow; **G.** —gyilis, gyā'lemgyilis, autumn.
- cousin*, **N.** ne'muōt; nene'muiutāla, cousins and brothers; **N.** **L.** **H.** nō'la, parent's elder brother's or sister's child = elder brother; ts'ā'ea, parent's younger brother's or sister's child = younger brother.
- cover*, **H.** tāk k'; tak'k'ēā'la, cover over head (—k'ēa, head; —la,

r.) ; tã'k'umt, *to cover face with blanket.*
crab. **L. N.** k'õ'mis (—*is, sea*) ; k'õ'tsatsë, *young crab* (—*tsatsë, young*).
crack in dish. **H.** koëk'oa'tloa'la.
cradle. **L.** qaã'p, **A.** qap'ë', **G.** qãbq, *infant.*
crazy. **N.** nõ'ntsistal ; nõntsistã'latl, *dancing like a madman* (—*latl, dancing, acting*).
crooked. **L. N.** k'õ'tlala ; **N.** k'õ'k'oigya, *with crooked back* (—*igya, back*) ; k'ã'lõkwis, *crooked land* ; k'antlanëã'la, *to walk crookedly.*
crossbeam over door of house. **H.** gaitsoa' (—*tsoa, inside*).
crown of head. **L.** õqtlë'n, **H.** k'ã'tsoak'ë'a (—*k'ëa, head*).
to cry. **L. N. G.** k'õã'sa.
cup. **L.** koã'asta (—*sta, water*), **H.** nak'a'msta (nak'a, *to drink* ; —*sta, water*), **G.** nak'ai'ũ (—*drinking instrument*).
to cut. **N.** paqa'ia, **L.** paq'it ; **A.** k'oa'la paqa', *do not cut* ; lã'qsa, *to cut up* ; lã'qsent'ãë'noq, *one who knows to cut up* ; **N.** sakwa', *to cut meat* ; sakwa's, *place where meat is cut* ; **H.** qta, qtl-tsiüt, qtlã'kyëtsiüt, *to carve game* ; qõ'tltsia, *to cut to pieces* ; qtlptã'ut, *to make a cut in an object* ; k'õqskyana, *hand cut off* (—*skyana, hand*).
to cut tobacco. **L.** t'õ's'it, **H.** t'õs.

D.

dagger, long stone —, **H.** ts'õai'ũ.
Dã'gyulk', **N.** *name of a place.*
to make a dam across a river. **N.** tsũ'pa.
to dance. **L. N. H. G.** yiqoa' ; **N.** yiqõ'euë, *dancing cap* (—*euë,*

forehead) ; **H.** yiqstë'kya, *dancing apron* (—*ëkya, leg below knee*) ; yii'qstënsiüsë, —*leggius* (—*sitsë, foot*) ; yiqtu'mkëna, *Chilcat blanket* ; **N.** kyí'lkyilnala, *dance at night when novice returns* ; **N.** —latl, Tsõ'nok'olatl, *dancing like Tsonok'oa* ; **N.** ts'ã'ëk'a ; **TI. H.** ts'ëtsã'ëk'a, *winter dance* (= *secrets*) ; ts'ë'tsëk'ã'laiũ, *song used in winter dance* (—*ala, noise* ; —*aiũ, instrument*) ; ts'ë'qpëk', *pole used in winter dance* ; ts'ë'qpëk'ã'lagyilis, *dancing pole in earth* ; **N.** d'ë'nts'ik', *Sisiutl dancing pole* ; **N.** tõ'quit, *war dance* (**H.** *to walk*) ; **TI.** nõ'ntlem, *a winter dance* (= *foolish*) ; **TI.** iã'tiãti, *a summer dance* ; **H.** tlõ-olã'qa, *pollatch dance* ; **N.** ba'qus, *time when no winter dances are held.*

dancing implements (whistles and masks). **N. H.** nau'alak'.

dancing apron, noise of —, **TI.** ts'õk'oa'la.

darling. **N.** ã'ta ; *put-daughter,* ã'tak'a.

daughter, second. **H.** k'anioã'qtlëk's ; *only* —, hãu'ldsëk's (—*k's, female*).

day. **L. N.** nã'la ; nã'laqstãla, *having day in month* (—*qsta, month*) ; nãlaqõ'tau, *the sold day* ; nã-lagyiligya, *back of day.*

daylight. **N.** hã'nitsum, **H.** ts'ë'lqait.

dead. **L. N. H. G.** tlël ; **N.** —õtlë, *dead, past, broken* ; Tlatlësilõ'tlë, *the dead Tlatlësil* ; **H.** —lë, õ'mptë, *the dead father.*

deaf. **L. N. H.** gu'lkum ; **N.** gu'lkumqemtl, *mask of deaf man* ; **H.** guluk'õ'tutõ, *deaf on one ear* (—*atõ, ear*).

death, **N.** wānumgyila; wā'lagyila, *making die (only in song)* (wē, negation (?); —gyila, *to make*).

decayed tooth, **TI.** Nae'nsHE (—SHE, *tooth*).

deer, **L. N.** k'ē'was, t'čkyu's (= *struck against cheek*), k'ē'-**HUSTĀLA** (*Nuquēmīs name*), **H. G.** k'ā'mēla; k'ā'ntlila, *where always deer are found*.

Delphinus Orca, **L. N.** mā'q'ēnoq (= *pursuing secretly*), **A. H. G.** ha'iq'ēnoq (= *killer*).

dentalia, **N.** a'tlela.

to descend river, **H.** iuā'tūseLA (see *Fast*; —tūseLA, *down river*).

to descend mountain, **H.** kiinkqa.

to desire, **H.** meSELA'.

to dip, **N.** tsē'u'it.

dirt = *earth*, **N.** d'e'kyā, **H.** tek'um, **N.** ne'sa, tse'sa.

dish of earthen ware, **H.** qa'lk'oa.

dish, small grease —, **N. H.** ts'epā'-tsē, **G.** da'q'tla.

— *large*, **N.** tlō'k'ōō.

to dive, **H.** tā's'it, tā'sela; — *head-long*, **A.** tsastā'ak'a.

to divide, **N.** waqsi'stant (waq, *both*): **N.** māls'alitla, *to divide in half in house* (mātl, *two*; s'al, *in half*; —itl, *in house*).

dog, **L. N. TI. H.** wa'tsē, **G.** wa'ts; **N.** wā'sus, *eating dogs*.

dolphin, **TI.** tistawu'lk.

do not! **N.** k'oa'la.

door, **L.** t'e'nila, **TI.** t'ē'g'a, **H.** tl'ape'm.

down, —*aq*; **N.** tē'k'aqala, *to drop*; k'ā'seqala, *to walk down*; nek-ā'qala, *to beat time in slow measure* (= *straight down*); akyai'-aqala, *from above*; **L.** tse'qoaqala, *cataract*; **W.** alas'aga', *name of a dance* (= *great from above*); **H.** sōā'got, *to take down*; huē'tlaqals, *to fall down*; huē'-

tlaqitl, *to fall down in house*; lā'qa, *to go downward*; tq'oa'qa, *to jump down*; d'ō'k'oaqala, *to look down*; **G.** lā'qa, *to go downward*; d'ō'k'oaqa, *to look down*.

to look down, **L.** penk'e'mhit (pen, *below*; —k'em, *outside of round thing*; —hit, *v. a.*).

down river —, **N. H. G.** —tus(ELA); **N.** latū'sela, *canoe descends river*; latuseLā'gyilis, *to walk down river* (—gyilis, *land*), *sunrise*: Hēitlatō'sela, *coming down river* (*name of K'ā'nigylak' in L.*); **A.** toatuselā'gyilis, *sunrise*; iuā'tūseLA, *canoe descends river*; **G.** lā'tus, *to go down river*.

down (feathers), **H.** k'ōs.

to draw breath, **H.** tlhui't.

to dream, **H.** ky'ā'tlāč.

drifting at sea, **N.** tsē'tsa (*log of driftwood on which a person stands*); tsēnā'yō, *drifted out of river*; **H.** p'uqola'k'tlē, *a log adrift* (—tlē, *on sea*); kukiē'i, *many things adrift* (k'ai'nem, *many*); yā'k'ōō, *driftwood adrift*; yā'k'ois, *driftwood on beach*; k'a'lkūē, *body adrift* (k'alk—, *body*); k'au'qo-it, *canoe drifts away*.

to drill, **H.** sele'm.

to drink, **L.** nā'q'it; **N.** nā'nak'a, *trying to drink*; nāk'e'lkun, *I — often* (—elk, *expert*; —un, *I*); nanik'a'matsa, *wanting to give every one to drink*; nā'k'atsē, *bucket* (—atsē, *receptacle*); **H.** nā'k'a, *to drink*; nāqps, nāk'e'lk, *drunkard* (—qs, —elk, *expert*); nak'a'msta, *cup* (—sta, *water*); nā'k'am, *bucket*; nānā'k'em, *watertight basket*; **G.** nā'k'a, *to drink*; nā'k'aiō, *bucket*.
drowned, **G.** p'equē.

drum, **L. N. A. H. G.** menā'tsē ;
N. mā'menatsila, *taking care of*
drums.

drummer, **N.** mi'uila (= *striking*),
G. miuilis.

to dry salmon, **H.** kō'tl'a ; kō'las,
where salmon are dried.

drying frame, **H.** ka'l'iō.

dried salmon, **H.** qam'a's.

to dry, **N.** ts'ō'sa ; ts'ō'tēt, *fish just*
beginning to get dry ; ts'ō'temit,
coll. ts'ō'ts'ō'tem, *salmon, half*
dry ; **H.** tsō'sa, *dry* ; tsō'sk'ēa,
to dry head(—k'ēa, *head*) ; **G.**
ts'ū'sa, *dry* ; tsō'sems, *thirsty.*

to dry, **L.** le'muuit.

dry, **L.** k'aqō'la.

dull, **L.** iē'upa (= *bad point*), **G.**
p'aspē'luqpa (—pa, *point*).

dearths, **N.** gyngyiuā'nemis (= *child-*
ren of country).

E.

eagle, **L.** kū'ik, **H.** wīk' ; wī'kuilak',
painted eagle (—ilak', *made*).

— *whiteheaded*, **N.** miō'mēqpa
(mōk'oa, *white*) ; —pa, *point*).

ear, **L. N.** p'e'spaya, **H. G.** p'espē'-
yō ; **N.** (awa)to'ē ; ts'ēnā'tōla,
ear is sick ; **H.** —atoa ; waqsōdē'-
toa, *both ears* ; k'ōā'k'ootoa,
perforations of ears ; mō'koatō,
coll. mū'mkoatō, *earring* ; tl'ō-
qoatoā'lē, *ear is sick* ; kuluk'ō'-
lato, *deaf on one ear.*

earth, dirt, **L.** tsqems, **H.** tsqams,
N. —is ; **N.** heistā'lis, *around*
the world (—ēista, *around*) ;
ē'tēlis, *again in earth* ; nemō'-
kwitsālis, *alone on flat ground* ;
—gyillis ; kuč'qalalagyillis, *coun-*
cilor of his own country, of
earth ; ā'nk'oalagyillis, *his land*
cloudy ; tlā'tlaēgyillis, *whale*

blowing on land ; ts'ēqpēk'ā'-
lagyillis, *dancing around dan-*
cing pole in earth.

east, **N.** metla's (**L.** *southeast*), **H.**
nelk' ; **N.** mētlā'lanuk', *having*
east wind.

to eat, **N.** ha'mu'it ; lemen ha'mu'it
hē't'ēta, *I eat again* ; hamu'it-
ten, *I am eating* ; hamu'it'len,
I am going to eat ; ha'msa, *to*
eat ; hā'maa, *trying to eat* ;
hamā'putlen, *I pretend to eat* ;
nā'quamku hamā'pa, *all eat* ;
hā'mk'olisem, *I eat together with*
— ; hamaā'k', *eaten* ; hame'lk,
pl. hehē'melk, *eating much* ; ha-
me'lkun, *I eat often* ; (—elk, *ex-*
pert) ; hamasā'hagyillis, *look-*
ing for food all over world ; ham-
ē'lagyiliten, *I eat continually in*
house ; **H.** ha'msa, *to eat* ; ha'm-
sps, ha'mtsilk, *enter* ; hā'm-
ats'a, *trying to eat* ; hā'meh'it,
to take water and spit it out
again ; hamasā'oa, *rests of food*
(—āoa, *refuse*) ; **G.** ha'mspis,
hamdzi'lek, *enter* ; hamdzai'ō,
spoon ; ha'mstoa, *to eat walking* ;
ni'msela, *to know to eat* ; ha'm-
ts'aqlilē, *rest of food* ; hā'm-
ts'imas, *food.*

to eat meat, **N.** k'asā' ; k'ak'ēk'atsā'-
la, *always wanting to eat meat* ;
k'atsa'la, *sound produced by peo-*
ple eating meat ; **N.** wā'sus, *to*
eat dog flesh ; beqbā'k', *to eat hu-*
man flesh ; baqbaku'latl, *always*
eating human flesh ; kwā'k'uq,
eating biscuit ; neqñā'k', *eating*
sallaberries ; leqlā'q, *basket*
eater (?) ; g'ōā'tg'ut, *eating*
huckleberries ; k'ō'kyes, *to eat*
much (k'ō'nem, *much, many* ;
—es, *to partake of*) ; **G.** k'ā'-
ikes, *to eat much.*

ebb tide, **L.** g'ā'tsaqala, **H.** tl'ō'pū'it.

- eclipse of sun*, **N.** nek'ē'k' (= *sawaloved*).
- egg*, **L.** ts'ē'k'unō; **N.** ts'ē'kuat, *egg-island*; **H.** k'ē'lqamīn.
- edge*, **N.** —nqē; mākyinqēlis, *at end of a row on beach*; gyō'q'ēnqē, *house on edge*; k'āsēnqentāla, *to walk along a plank*; ōqse'nqē, *one side of a flat object*; Nōmase'nqēlis, *oldest of all*; wu'nqē, *edge of a flat object*; waqse'nqē, *both sides*; wa'q-sēnqēlis, *one on each side*; ama-ī'nqē, *smallest* (= *small at edge*); **H.** tqu'neqaut, *to jump along*; wīwu'nk'apois, *bottom of sea* (—apoa, *under*; —is, *in sea*); tsā'inqē, *youngest child* (ts'ā'ea, *younger brother*); **G.** wu'nk'q, *edge of flat object*.
- eight*, **N.** mā'tlguanatl, **H.** yū'tquaus, **G.** yutqā's.
- eighteen*, **N.** mātlguanatlagyū, **H.** yukquau'sgyū, **G.** yūduqōās-gī'u.
- eighty*, **H.** yutqsūkaus, **G.** yūduq penkyā'sk'ā'pō.
- elbow*, **H. G.** tlā'koanē.
— *joint*, **H.** āā'ē'.
- eleven*, **N.** ne'n.āyū, **H.** menē'egyū, **G.** na'qugī'u.
- elk*, **L.** tlō'ēls; *Xuquēmī's name*: nenō'elō (= *foolish*); **H.** tlāō'ls (—is, *outside* (?)); **G.** wudzi'ii.
- empty*, **L.** lō'pītl, *empty house*; lō-puēpītō, *you have no teeth in mouth* (—nē, *tooth*); **H.** lōpq̄s, — *canoe* (—qs, *in canoe*); lō'pītl, — *house*; lō'pēs, *inside of man empty* = *hungry*; lōu'mtsoa, — *dish* (—tsoa, *inside*); lōpla', *a hole, a piece missing*.
- end of anything*, **N.** mā'qpē.
- enough*, **N.** wī'k'asēla, *not to have enough*; wē'k'as, *idem* (wē, *negation*); wī'emk'asēla'sōqtis, *with which he was not satisfied (in song)*.
- to enslave*, **N.** k'ā'k'akwis (k'ā'kyū, *slave*).
- to enter*, **TL.** gya'q̄tsoa (gyaq—, *to come*; —tsoa, *into*); **H.** lā'tsoa (lā—, *to go*).
- to be envied*, **N.** liē'nakyała (—kyala, *noise*).
- ermine*, **H.** gy'ī'lem.
- European*, **G. H.** k'ōmūsī'ua (k'ōm—, *rich*; —ūsī'ua, *at mouth of river*); **H.** k'ōmūsī'uaakyała, *language of white man*.
- evening*, **L.** tsā'k'oa, **G.** p'ā'nequit.
- to examine*, **H.** d'ō'k'oa (see *To see*).
- expert*, **N.** —pes; tl'ē'tlespes, *angry*; lāq'ōtpes, *expert in breaking coppers*; **H.** nāqps, *drunkard*; kōhpis, *sweating*; hamsps, *eater*; **G.** ha'mspis, *eater*.
- , —*Elk*, **N.** hame'l̄k, *eater*; hame'l̄kun, *I eat often*; **H.** nak'ē'l̄k, *drunkard*; ha'mtsilk, *eater*; **G.** hamdzi'lek, *eater*.
- to extinguish*, **L.** ku'ī'lqit, **H.** ku'ī'lqa-eye, **L. N.** k'ā'yak's; k'ayak'ēsak'ōs, *thy eyes*; **N.** (ōstō'ē) *eye*; gyīs-tō'ē, *something in eye*; ēikī-sōqstō'ē, *with pretty eyes*; **H.** k'ks, *eye*; —qstoa; hā'paqstoa, *eyelashes* (hap—, *hair*); k'oa'qstō, *one eyed*; bā'koanēmqs-toa, *pupil of eye* (= *man in eye*); tl'ōqstoa'lē, *eye is sick*; wunk'ē'qstoa, *lower eyelid* (= *edge of eye*).
- eyeball*, **L.** k'ēpelu'qstoē (—stoē, *eye*), **H.** k'ā'pelē'.
- eyebrow*, **L.** ā'an, **H.** aaini'ii, **G.** aa'nii.
- eyelashes*, **L.** hā'pēlik' (hap—, *hair*); lā'paqstoa (= *eye hair*).
- eyelid*, **L.** k'ēpelu'qstoē (?) (—stoē, *eye*); **H.** ōwē'kyatltoa, *upper* —; wunk'ē'qstoa, *lower* —.

F.

- face*, **L. H.** k'ō'k'omē; **L. N.** —mē, tl'ē'semē, *skin of face*; **L.** k'oate'mēya, *scar on face*; ō'nutlemē, *check (= side of face)*; mē'maatlemē, *two faces*; **H.** —mē, —ma; tl'ōqoma'lē, *face sick*; k'u'smē, *skin of face*; alk'mā'la, *face bleeds*; ōwa'mia, *check*; ts'ō'tsoqma, *to wash face*; **G.** hāitlkyutemē, *right side of face (= kyut, opposite)*.
- facing*, **N.** —k'am; ōk'amālis, *facing beach*; ha'nk'amālis, *canoe in front of beach*; ā'tlk'am, *hind side of man, box (= facing backward)*; ā'tlk'amala, *house facing woods*; Nā'nk'amālis, *bear facing world*; kuā'k'amā'tla, *facing river mouth*; k'ōk'ōmā'lis, *canoe lying on side in front of beach*; **L.** tlas'kamā'tlin, *I stand facing sea (=tlē, surface of water)*; **H.** ōsk'amē'kya, *back (=čkya, back)*. See also **N.** sintlē'k'am, *face of Sintlaē*; minstēk'ē'mt, *to strike face. It would seem that —mē designates: face*; —k'am, *an action performed with the face*. See also *Outside of round object*.
- face, upper part of*, **N.** —tem; gyi'ls-gyiltem, *the long-headed ones*.
- to fall down from an elevated position*, **H.** nuē'tlaqitl, — *in house* (—aqa, *down*; —itl, *in house*): nuē'tlaqals, — *outside (als, outside)*; nuē'tla, *to fall into water*.
- to fall, to roll down hill*, **N.** k'u'mia; k'ōmēnē'tē, *explained as: everything falls upon him*.
- to fall down (walking)*, **H.** ku'ā'ns'ē'nem.
- to fall*, **L.** ku'i'uals.
- to fall (tree)*, **L.** tā'n'it, **H.** kuilā'q'it.
- to fall to pieces*, **N.** tlē'na.
- to fall*, **L.** tō'q'it; tē'q'itlala, *to fall into fire (=qtlala, flames)*.
- to fall into water*, **L.** elā'ts'ō.
- river falls*, **L.** kyō'tla.
- family*, **H.** manō'ma (see *Gens*).
- famous*, **N.** ts'ē'tloala; K'ā'laitē (*name*), *explained as: famous*.
- far*, **N.** k'ōē'k'; **L.** k'ōē'sala, *it is far*; k'ōē'k'sōt, *far away on other side (=sōt, on other side)*; K'ōē'k'sōt'ēnoq, *people on the far other side*; k'ōē'sōtē'nqēlis, *far other side, end of world* (—Enq, *edge*; —lis, *land*); k'u'i'seila, *to go far off*; **H.** quē'sala, *far*.
- farthest*, **N.** —k'aua; bē'benak'aua, *the lowest*; ē'kyak'aua, *above*; aōlak'oak'aua'sō, *speaking in lowest tones*; nanō'ak'aua, *the wisest one*.
- to fart (said of male and female)*, **H.** wa'qua.
- fast*, **N.** i'na; i'hak'amē, *the fastest one*; wē'hala, *slow* (wē—, *negation*); **G.** hā'lagyilis.
- father*, **N.** ōmp, **H.** āu'mp, **G.** āpf; **N.** ō'mptē, *dead father*; **N.** addressed: āts, āts; *addressed by children*: dā'da.
- father-in-law, mother-, son-, daughter-in-law*, **L. N. H.** negn'mp.
- fathom and subdivisions*: *fathom*, **L.** pā'tl'it, **H.** pā'tl'a; *one fathom*, ō'p'enku; *two —*, mā'tlp'enku. — *left elbow to fingertip of right hand*, **H.** k'asē'ta'k'. — *left shoulder to fingertip of right hand*, **H.** asō'tqa-int. — *middle of chest to fingertip of right hand*, **H.** asō'd'apōt (—apoa, *breast*). — *right shoulder to fingertip of right hand*, **H.** k'ā'pōt.
- fawn of deer*, **H.** d'ōphē'wa.

to fear somebody, **N.** wa'lipolo.
feared, **N.** gyi'lEM; gyi'lEMkyas,
the one really feared.
to feast, **N.** k'uī'las; k'uī'lastEMs,
place where feasts are regularly
held; k'ō'lselas, people going
to a feast.
 — *to give a feast*, **L.** tlē'la.
feathers, **N.** k'a'mqua; k'a'mquaq-
 stalis, *feathers on mouth on*
beach.
 — **N. H.** ts'i'lKEM, *coll. ts'el'ts'E'-*
lku; ts'i'lkyEmpa, feathers on
top.
 — *wing* —, **L.** p'E'tLEM.
to feel, **N. H.** p'ē'hula; iā'kuis
 p'ē'hula'sō, *bad to feel; H.*
 p'ēpēyo'k'a, *to feel among*
 (—ak'a, among).
to fell a tree, **H.** tlā'k'ama.
fellow, **L.** kyā'gyiqa (?); —lōt; **N.**
 gyō'uklōt, *tribe (= village fel-*
lows).
fern, **L.** sā'kuam (*Pteris aquilina*);
 — *root*, **L.** sā'kum.
 — **H.** k'ē'sTEM.
to fetch fire, **L. A.** ā'noa; **L.** acano-
 ā'tLEM, *I am going to* —; **L.**
 anē'k'a, *to fetch fuel.*
few, **L.** hō'latlpetā'ō (—pētāō. *small*).
to fight, to make war, **N.** qō'metlela.
to fight, **L.** khū'q'uit.
 — *against each other*, **H.** ts'ē'katla.
 — *always fighting*, winā'lagyilis.
 — *fighting place*, hā'k'oqTEMS.
fin of whale, **L.** tlā'kya (—ēgya, *back*).
 — *dorsal fin of fish*, **H.** ts'E'mtē-
 gya (—ēgya, *back*).
 — *anal* —, **H.** temtemua'tsē.
 — *pectoral* —, **H.** k'a'lk'alk'EM.
to find something unexpectedly, **N. H.**
 tlō'k'oala; *this term is used es-*
pecially for meeting a supernatu-
ral being; tlō'k'ōē, what is found
unexpectedly.
to find while walking, **N.** k'āk'asky-

inā'la (see *To walk*); *in songs* :
 tayukuinā'la.
hand and fingers, **L.** k'oa'k'oaqtsanē
 (—tsanē, *hand*), **H.** k'ā'k'oaq-
 skyā'nē (—skyānē, *hand*), **G.**
 nihnaqsky'ā'nē (—sky'ānē,
hand).
first finger, **L.** ts'ē'mala, **H. G.** ts'EM.
second —, **L.** nō'la (=elder brother),
H. k'ōm. **G.** k'ā'qtē.
third —, **L.** ā'lt'aq, **H.** ss'ā'lō, **G.** sāl'lē.
fourth —, **L.** kh'ēt, **H.** kh'ē'ta, **G.**
 kyida'.
finger ring, **L.** k'ē'k'ateqtlē, **G.** k'ē-
 k'et'gyā'nē.
fir, **L.** iaiaqpā'lamis (—mis, *tree*),
H. anē'oas (=fuel (?)).
fire, **N.** hē'k'ala; hēk'ālā'la ni'kyē,
mountain is on fire; L. N.
 le'k'ōitl, *fire in house; —qtlala,*
fire, flames; ō'qtlala, flames;
tu'qtlala, to jump into fire;
hāntlala, kettle on fire (han—
vesel); k'antlalatsē, great fire
(k'ai, much; —t-ē, large);
tē'qtlala, to fall into fire; H.
qui'llela, fire; leguī'las, fire-
place (—il, in house; —as,
place): t'qtlā'lis, to jump into
fire; G. qulika'ā'gē, fire;
k'aiutlala, large fire; t'qtlā'la,
to jump into fire; qu'ltqulta,
lightning; kha'k'italōda'tsē, ket-
tle (—atsē, receptacle).
fire drill, **L.** ā'nek', **A.** anō'ku, **H.**
 anō'k'.
base of fire drill, **H.** aq'ō'k (used
 with ear wax).
firm, immovable, **N.** a'latlē; alē's,
immovable in ground; alē'tl—
in house; alē'tSEM, firmness.
first, **N.** gyil; gyilgyilā'itl, *ancestor*
 (=first of house); gyā'lamus-
 tāla, *salmon beginning first to*
ascend the river; H. gyā'la;
 gya'lu'it, *first time.*

fish, **H.** mā'gyilis (see *meā'*, *s ilmon* ;
—gyilis, *carth* = *all*).

— *sp* (?), **TI.** t'ō'tōp.

— *sp* (?), **TI.** qō'ltsus.

fishline, **L.** k'āk', **H.** k'uue'm.

— *for deep sea*, **L.** mak'ā'noē, **H.** me'lek.

fish, **L.** k'ōē'k'otse'māē.

five, **N. H.** sky'a, **G.** sikyō'q; — *round objects*, sikyā'sk'em ; — *long objects*, sikyātsq.

fifteen, **N. H.** sky'a'gyū, **G.** sikyā-gū'u.

fifty, **H.** sky'ā'ksuk, **G.** sikyapenk'ā'pōpena

flagstaff, **N.** semtlē'p'iq (—p'iq, *pole*).

flat land, **N. A.** ōtsā'lis, **N.** Nēmō-kuistā'lis, *alone on flat, open land*.

flee, **L. H.** tōpēatsē.

floodtide, **L.** iū'nak'oa, **H.** ī'ī'oit.

to flood, **N.** d'ā'jā : d'apalī's, *covered by tide* ; d'ape'lis, *to flood ground outside of house*

floor of house, **N.** —itl, **H.** wīl.

flower, **L.** k'ōā'san.

— *sp.* (?), *a white* —, **H.** k'ōī'k.

— *sp.* (?), *red and blue* —, **H.** mats'ē'k'ola.

to fly, **L.** tlanā'k'ua, **H.** mā'tela ; mā'tēa, *to fly above something* ; mā'taput, *to fly below* (—pōl, *below*) ; mā'tlmatem, *wings*.

foam, **N.** ā'owē ; ā'watsē, *large foam (name of a place)*.

fog, **L.** p'e'lqela, **H.** ā'nk'oola, **G.** a'nq'ank'ōē (see *Cloud*).

food, **H.** hā'mts'imas (*ham* —, *to eat*) ; hā'mts'aqtlē'e, *rest of food*.

foolish, **L.** nenō'lō, **N.** nō'ntlem, nenō'lō ; nōlō'kamē, *greatest fool (mythical name of porcupine)* ; Nōlōyūēgyilis, *fool in middle of canoe on earth* ; Nū'tlemistalitse'mk'ua, *female, all*

around foolishness (—ista, *around* ; —sem, —ness ; —k'ua, *female* = *male to walk around everywhere like a fool*) ; Nū'tlk'alagyilis, *always acting like a fool* ; Nū'tlnū'elī'kya, *highest of all fools* ; Nū'tlatla, *similar to a fool* ; Nū'tlamō, *born a fool* ; Nō'ntlemgyila, *making foolish*.

foot and leg below knee, **N.** gyūkoīū', **L.** gyū'koāē, **H.** kō'kuē', **G.** gyū'goē.

— **N. H. G.** (ōq)si'tsē ; ō'p'atsētsē, *foot of an object* ; **L.** ts'ōqt-ō'is'tsē, *hoofs* ; ō'qlak-sī'tsē, *heel* ; **H.** amēa'tltsīsē, *skin of heels* ; yī'iqstēūsīsē, *dancing leggins* ; k'uk'ntsī'tsa, *skin of feet* ; **G.** dzū'qlzqudzīsa, *dancing leggins*.

forehead, **N.** —ēōē, **L.** ō'kwēōē, *forehead* ; ai'kyā'ōē (= *good forehead*) ; k'ōats-ē'ōē, *scar on forehead* ; ts'ēqē'ōē, *dancing cap* (ts'ēk'ua, *secrets*) ; **TI.** yī'qōēōē, *dancing cap* ; tl'ēsī'ōē, *skin of* — ; nī'sī'āē, *wolf's head mask for Tlōkoala* ; ōkū'iatlē, *forehead on sea* (—tlē, *on sea*) ; **H. G.** tak'ē-īōa', *forehead* ; **H.** k'ā'kēīōa, *glabella* (= *notch in forehead*?) ; qapē'īōa, *head presser* (qapē, *cradle*) ; tl'ā'k'ōēīōa, *headdress of cedar bark* (tl'āk'ok', *red*) ; tlōqēīōa'la, *forehead is sick*.

forest, **L.** ā'tlen (= *inland, behind*), **H.** k'ā's.

foundation, **N.** ky'ā'k'atla ; ky'ā'k'ua, — *on stone* (—a, *stone*) ; ky'ā'k'is, *house founded in water* (—is, *in water*), *pile dwelling*.

to founder, **L.** wuns'it.

four, **N. H.** mū, **G.** mūq.

fourteen, **N. H.** mū'agyū, **G.** mūa-gū'u.

forty, **H.** mōk'suk, **G.** mōpen k'ā'-pōpena, **N.** Mamō'sk'amee'n-koa, *carrying four round ones*.
fox, *white-tailed* (?), **H.** mōk'uqt (mō'k'oa, *white*; —qt, *end of body*).

fragment, **N.** —tses; quā'kunatSES, — *of canoe*; qa'l'k'oatsES, — *of dish*.

those free from Tsētsā'ēk'a, **N.** k'uē'-k'utsē.

my friend! **N.** k'āst.

to frighten, **N.** hawī'natla.

to be frightened, **L.** ts'ē'tlkya.

frog, **L. TL.** wok'ā'c, **H.** atsi'.

front, **H.** tl'ās—; tl'ā-k'am, — *of box*, *man* (—sk'am, *outside surface*); tlā'satsē, *painted front of box*; tlā'sanoa, — *of house*, *island*, *round object*.

fuel, **L.** lē'k'oa; *fireplace*, lē'k'o-itl (= *fire in house*).

full, **L. H. G.** k'ō'uta; **H.** k'ō't'auq gis la'mhimisa, *this box is full of food*.

to make fun of somebody, **N.** āa'mt-lala.

to make fun of somebody's words, **N.** guā'k'wāla.

funnel for mending kelp bottle, **N.** ts'ēts'equmēā'wāē.

fursal, **L. N.** qā'oa.

future, **L. N.** —tl; ganē'mtl, — *wife*; quā'kunatl, *canoe that is making*.

G.

game of hoops, **N.** gyā'naē, **A.** gyā'-natala.

game (children stand in a circle around one who tries to make the others laugh by tickling them), **A.** quā'ni.

gens, **N.** nēm'ē'mut.

ghost, **L. N.** bakuinē'i (*from bākus*,

man). lā'lēnoq (—ēnoq, *people*), **H.** lōa'tl; **N.** lōlō'tlalatl, *ghost dance* (—latl, *dance*).

giant, **N.** hē'itsē (= *the great one*; —tsē, *great*).

gills, **L.** k'ō'senāē, **H.** g'u'ntsē.

girl (about twelve years old), **L.** kya-yā'lam (= *little woman*), **H.** g'ānē'mō.

to give, **N.** ts'ā, **H.** tsoā'.

glabella, **H.** k'ākēioa' (k'āk—, *notch*; —ēioa, *forehead*).

to gnaw, **N.** ky'ā'pa, **H.** gy'ā'p'ēt-ō.

to go, **L. N.** la—; lō'otlō, — *out of canoe* (—ōilt, *out of canoe*); laqta'la, — *out seaward*; la'laō-tla, *always going across*; laqs. — *into canoe* (—qs, *in canoe*); lē'istala, — *around* (—ist, *around*); latu'sela, *canoe goes down river*; latu'selagiyilis, *walking down river*; **G.** lēā'tl, *to enter* (—itl, *in house*); laqs, *to go into canoe*; **H.** laai'tl, *to enter* (—itl, *in house*); laai'tla, *to carry into house*; laq-ī'ua, *to go through*; lā'qa, *to go downward* (—aqa, *down*); lēnakula, *to go moving towards an object* (—nakula, *motion*); tōua', *to walk*; tōtsoa', — *over a plank*; tōkoia', — *over a pile of planks*.

— **N.** g'ō'lselin laq John, *I am going to John*.

to go to look for —, **N.** —uia; qeā'qoakua'la, — *canoe*; hā'-natlailala, — *canoe* = *to go to buy a canoe*; hamasuiā'lagiyilis, *always going about to look for food*.

go on! **L.** wēkiā'a.

god, **L.** k'ants'ō'ump (= *our father*); k'ants amiqala'soē (*whom we praise*).

good, **L. N.** aikn, **H. G.** ain; **N.** aiwakā'la, *good among others*;

e'igiytlala, good on water; *ia'q-num*, bad; *ia'kuim*, cause of evil; *e'ikuim*, cause of good (luck, etc.); *e'ikun-ōqstō'ē*, with pretty eyes; *e'iky'ēs*, sand (= good beach); *aihp'aqsta*, to speak good of one; **H.** *aiknits-kolis*, good, flat beach; *iaku*, bad; **G.** *ainpa*, good taste; *aihp'a'la*, good smell; *aigyitsui's*, sand (= good beach).

good-by! **L.** *alā'kyasla*, **H.** *wilē'-itsēqa*.

goose, **L.** *ne'qāk'*.

grandfather, **L. N. H.** *g'ā'g'ēmp* (*g'āg'a's*, *thy* —), **G.** *g'ag ā'p*.

grandson, **N. L.** *ts'ō'qtēma* (*ts'ō'qtēma* (?)), **H.** *ts'ō'qtēma*.

granddaughter, **N.** *ts'ō'qtēmak'as* (*ts'ō'qtēmak'as* (?)) (—*k'as*, *female*), **H.** *ts'ō'qtēmak's* (—*k's*, *female*).

to grasp, **L.** *k'ō'ēsāt*, **N.** *čā'n'it*, **H.** *tqsemē'*.

grass, **H.** *ky'č'ēm*; **N.** *ky'č'tōkwis*, *grassy place*.

grave, **L.** *tēgyā'ya*, **H.** *tsuwī'k'*, **A.** *alā'k'*.

— *of chief*, **A.** *tk'alē'em*.

— *in tree*, **H.** *ky'ā'kqlatlak'* (see *Foundation*).

graveyard, **A. H.** *al'aiā's* (—*as*, *place of*).

great, **N.** —*tē*; *sā'tsē*, *great man*; *hō'its-ē*, *giant*; *Nā'ntsē*, *great bear*; *nā'k'atsē*, *the great wise one*; (see *Large*); **H.** *k'aiē'kyas*, *really great* (see *Many*).

great among —, **N.** *Nēm'č's'ānatl*, *the greatest among the Ninkish*; *gyčqsem's'ānatl*, *the greatest among the gyčqsem*.

great-grandparent, **N.** *hē'lus*.

great grandchild, **N.** *hē'lōgwinē(m.)*, *hē'lōgwinēk'as* (*f.*), **H.** *tlētlau-lstoā*.

great-great-grandfather, **N.** *č'ā'os*.

grease of blachen, **H.** *tlē'na*.

grebe, **N.** *k'ō'taq*.

green, **L.** *tlē'nqa*, **H.** *tē'qa*; *tē'qsem*, *green blanket*.

ground, **N.** —*gyis*.

grouse, **L.** *hōmhōm* (?), **TI.** *mā'k'ō-als*, **H.** *mkyels* (—*als*, *in woods* (?)).

group of, **N.** —*qsem*; *t'ā'tloqsem*, *copperplates tied together*; *gyč'qsem*, *a group of chiefs*.

to grow, **N.** *k'ō'ā'qa*.

gum, **L.** *k'ōalī'ku*, **TI.** *k'ōā'k'ōalē*, **H.** *k'olē'n*.

gun, **L.** *hā'ntlem* (see *Arrow*), **N.** *hā'natlalala*, *to go to buy a gun*, **G.** *kyidai'ō*.

gutts, **H.** *ts'ē'i'ē'm*.

Gyīmanoitq, **G.** *Qanā'ks'iala*.

Gyītamut, **H. G.** *Qāisla'*.

Gyītamut language, **G.** *awī'kyala*, = *correct noise*.

II.

Haida, **H.** *Haida*, **G.** *Qa'ēdaq*.

to hail, **L.** *tsi'lqa*, **N.** *tsi'lqm̄is*, **H.** *tse'lq̄is* (= *knowing to* —), **G.** *tse'lqa*.

hair, **L.** *sā'ya*, **G. H.** *sī'a*, **L. N. H.** *hap*—; **L.** *hapa'qstēya*, *beard* (= *mouth hair*); *bā'pēlik'*, *eyelashes*; *hapa'mtsō*, — *in armpits*; *hāpēhsia'*, *chin beard* (= *tooth hair*); **H.** *hapta'ē*, *beard* (= *mouth hair*); *hā'paq-stoa*, *eyelashes*; *hā'mtsoa*, — *in armpits* (—*tsoa*, *inside*); **G.** *hā'bilii*, *eyelashes*.

half, **L.** *nek'ō'ioi* (see *Middle*), **H.** *k'ā'ns-ē*, **N.** *sō'ps'al*, *to cut in half*; *sōps'a'lsa*, *to cut in half in woods*; *sōps'alī'sa*, *to cut in half on beach*; *mātls'alī'tla*, *to divide into two halves in house*.

- half breed*, **N.** mā'matl'atsē (= *young of white man*).
- halibut*, **L. N. H.** p'ō'ē.
— *dried*, **H.** d'ā'lōs.
— *fabulous*, **N.** nemhā'likyō.
- haliotis*, **L. N. A. H.** ai'htsum; **N.** Aihsumā'litlilak', *made — in house*; Aihsumk'amlitl, *covered with — in house*; āl'ēih-
isem, *real — (?)*; **A.** Aihsum-
k'anak'.
- Hammer's w.*, **N.** hā'mats'a, **H.** tanī's.
hammer, **N.** liky'ai'ō.
—, *stone*, **L. N.** pe'lpeik, **H.** p'ā'-
yoq, qā'utsē; p'ā'yoq t'ē'sem-
ā'qa, *the hammer is of stone*.
- hand (and fingers)*, **L.** k'ōā'qoaq—
tsanē, **H.** k'ōā'k'oaqskyanē
(*hands*); haiā'sō, **G.** hā'isū;
L. N. — tsana, tsānē; k'em-
qōtltsā'na, *left —*; t'l'ē'stsānē,
skin of —; hē'tlkyutts'ā'na,
right — (= right opposite hand);
k'utsā'nē, *scar on —*; t'at'i'q-
tsāna, *to scratch —*; **H. G.**
—kyānē; k'uk'uskyā'nē, *skin
of hands*; hā'itlkyutts'ā'nē,
right —; k'oqskyā'na, *to cut
off —*; al'nskyānā'la, *blood on —*;
ōwē'gyatlkyā'nē, *back of —*;
pāk'atlkya'nē, *palm of —*; **G.**
niunaqskyā'nē, *fingers*; k'ē'-
k'etgyā'nē, *ring*.
- to hang over rope, v. n.*, **L.** k'ā'q'uit.
— *v. a.*, **N.** k'ē'hoā; k'ē'us, *wash
line (= place of hanging)*; k'ē-
hustāl, *woman hanging wash
(—usta, up)*.
— *one's self*, **L.** mō'kuaqōt (mōq,
to tie (?)); —aqa, (*down*).
- to hang on to nail*, **L.** tē'kuitl; **N.**
tēk'uqstā'ē, *something hanging
down from mouth*.
- to make happen*, **N.** k'ōē'gyilisa.
happy, **H.** aikyek Ela' (see *Good*).
hard, **L.** p'ē'isa.
- harelda glacialis*, **H.** ā'anak'.
harpoon for salmon, **L.** alē'winoq,
k'atlāya (k'atlā'yō (?)), **H.** ts'-
ā'kyem.
— *double point of —*, **H.** kqpa
= *notch point*.
— *shaft of —*, **H.** mā'siūtł.
scaling harpoon, **N.** māstō.
- hat*, **L. N.** tleie'mtl (—emtl, *head
cover*), **H.** k ā'it; **N.** gyē'k aml,
chief's hat (—gyē, chief); yiq-
u'mtl, *head mask (= duncing
head cover)*; **H.** t'l'ē'kyimtl,
wooden hat for war.
- to hate (see Envy)*, **N.** tlē'selasuē,
the hated one; hā'inakyalasō,
the hated one; hē'nakyaala, *to
hate, to slander (?)*.
- hau-hau*, **H.** hā'ok'hāok'.
- to have*, **N.** aqnō'kuatē, *he has it*;
—nuk, *having*; Metlā'lanuk,
having east wind; Koanilanō'-
kunē, *having smoke = who always
gives away smoke*.
- head*, **L.** qums, **H. G.** haintē; **H.**
—k'ēa; k'usk'ēa, *skin of head*;
t'l'ōqk'ēā'lē, *head is sick*; tak'-
k'ēā'la, *head cover*; k'ā'tsoa-
k'ēa, *crown of —*; tsō'sk'ēa,
dried head.
— *to cut off head*, **L.** k ā'p'it; **L.**
N. k'ā'gyik', *head cut off*; **N.**
qauē'k', *head cut off*.
- head ring of cedar bark*, **Tl.** k'agē-
ma'la tlā'k'oq, **H.** t'l'ā'k'ōēioa
(—ēioa, *forehead*); **N.** Yiqumā'-
lakilak', *made to use head dress*.
- head presser*, **H.** qapē'ioa (qap'ē,
cradle; —ēioa, *forehead*).
- head, top of a thing*, **N.** ō'qtlē.
— *of river*, **N.** ōgyēqtōē
— *of land, cape*, **N.** ō'kuitemē;
Ō'kuitemālis, — *on beach*.
- to hear*, **H.** hā'umētl, k'ā'uwatela;
k'ā'wat'ēs, *with good power of
hearing*.

- heart*, **L.** no'k'ē, **N.** nā'k'āē, **H.** wa'stēma.
- heaven*, **TI.** lō'ua, nā'la, **A.** lēua'; **N.** lē'nagyila, *heaven maker, name of the raven.*
- heavy*, **H.** goiō'k'.
- heel*, **L.** ō'ɬlaksī'tsē (—sītsē, *foot*), **H.** ō'ɬlā'tlmoa.
- hemlock*, **L.** tlē'nēk; **TI.** koa'q, **H.** lō'k'oa's.
- hermaphrodite*, **H.** koa'lk'.
- herring*, **L. H.** wā'nē; **H.** waā'nē-gyila, *where herring use to come.*
- *roe, fresh and dried*, **H.** ā'nt.
- *rake*, **L.** tlētā'io
- to hew with axe*, **L. N.** sō'pa; sō'paiō, *axe (—aiō, instrument)*; **H.** k'ō'koa.
- to hide*, **L.** wu'na.
- high*, **L. N.** ai'ky'a, **H.** aiky'ē (see *Above*).
- high water*, **L.** t'ē'tēpēmē; **H.** iqōē't, *it is flood*; iqumē', *it is high water.*
- hill, gently sloping*, **L.** aikuiūēū (see *High*).
- to hit*, **L.** k'ā'pa.
- to hold by ear*, **N.** nī'sa.
- hole*, **L.** ko'qsoala, **N.** guā'qoē; **H.** guā'p, *torn, no piece missing*; lōpla', *a piece missing (see Empty)*.
- hoof*, **L.** ts'ōqtsōqsi'tsē (—sītsē, *foot; distributive*), **H.** kskinā'tl.
- hook*, **L.** k'ē'taiō, tlā'k'aiō, **H.** k'ā'tlaiō, ak's.
- horn*, **H.** wutlē'm.
- house*, **L. N. TI.** gyō'k; **N.** gyigyō'qtsē, *large house*; gyōqsi'wāē, *house at mouth of river*; gyōq'enqē, *house on edge*; gyōq'tēms, *village site*; gyōgyōkōnūtlem-āla, *houses on both sides*; **H.** gōk'; **G.** gyū'kuila, *to make* —; gyūqtli's, *house at mouth of river*; gyūqstāis, *house is in water*; gyōk, *also: winter village.*
- house with many steps*, **TI.** tsō'ya-yuk'.
- **TI.** —tsēms, ō natse'ms, *large house.*
- *on piles*, **N.** ky'ā'k'is = *founded in water.*
- *housefellow*, **G.** wā'oitl.
- *inside of* —, *house floor*, —itl; **N.** ts'āi'tlēla, *to run into house*; tō'wīt, *to jump* —; d'ō'quūla, *to look* —; wā'wakulūla, *to bark* —; k'ē'tyēqsiā'litl, *carry-ing in mouth in house*; mō'tsūt, *chief's wife = keeping from floor blankets*; ku'mhelalūt, *clean house*; lē'k'ōitl, *fire* —; han-ī'tl, *kettle on floor*; d'ō'k'ōitlila, *to look into* —; lō'pīt, *empty* —; laa'itla, *to carry into* —; laa'itl, *to enter*; **G.** g'ōā'itl, *to sit in* —; wā'oitl, *house mate.*
- humming bird*, **H.** koā'kumta.
- hundred*, **G.** skyōq beguā'num = *five men.*
- hungry*, **N. L.** pō'sk'a; pōsk'anlōtl, *I am — to you*; **H. G.** pō'ēs (—ēs, *inside of man*); **N.** pawē'tsit, *one whom the hungry ask for food.*
- to hunt deer*, **H.** k'ā'k'amela (see *Deer*).
- to hurt one's foot*, **L.** iā'lelkoa.
- hunting box for canoe*, **N.** ō'tsaqs (—qs, *in canoe*).
- husband*, **L. H.** tlā'wudem.

I.

- I*, **N. H. G.** nō'gua; **N.** yin.
- ice*, **L. N. H. G.** t'ōq.
- Indian*, **N.** bā'k'um, **G.** beguā'num (= men).
- *of inland*, **N.** Lā'qolis, **N. H.** ā'tlasimih (ā'tla, *inland*).

infant, **N.** wī'sa, **G.** qābq (see *Cradle*).

inland, **N.** ā'tla ; atlā'lēnoq, *inland people* = *volees*.

inside, **N.** ōtsā, ōtsō' ; lā'tsūt, gyī'tsō', *to put flat object into a box* ; tle'nqtsūt, *to put long object into a box* ; hī'lqtsūt, *to put blanket, shirt into a box* ; k'apā'tltsut, *to put round thing into a box* ; aqtsū't, *to put anything into a box* ; kyā'tsō, *it is in box, lid closed* ; kyētsō'mō, kyā'taqtlēmō, *it is in box, lid opened* ; hape'mtsō, *hair in armpits* ; ts'ih̄tsā'la, *headache* ; **TI.** gya'qtsoa, *to enter* ; **H.** ō'tsoa, *inside* ; gyē'tsōt, *to put into* ; tuq'tsoa, *to jump into* ; lōu'mtsoa, *empty inside* ; lā'tsoa, *to enter* ; ha'mtsoa, *hair in armpit*.

— *a second thing inside a larger one*, **N.** hē'l'ō ; hēl'utsā'ls, *a small house in a larger one* ; hē'l'utsō, *a small lake in a larger one*.

— *of mouth*, **N.** awētlqā'ōē.

— *of salmon, birds*, **N.** awitsē'.

— *of man*, **H.** ōwa'qtē, **N.** —is ; sē'ilis, *snake in belly* ; **H.** —is ; lōpē's, *hungry* (= *inside empty*).

— *corner*, **N.** ō'nē.

instep, **H.** wī'gyatlsī'tsē = *back of foot*.

instrument, **N. H.** —aiō.

interstices of fingers, **H.** ōwaqts'Esā'wa.

inventor (see *Councilor*), **N.** kuē'q'ēnoq ; Kuēkuaqā'oē, *great* —.

to invite, **N.** a'etsēsta, *to invite all around to feast* ; k'ō'stītses, *to invite guests arriving in canoes to land*.

island, **L. N.** makyā'la, *distr. maa'mkyāla* ; mē'mkumlis, *islands opposite village* ; **H.** tl'ēkyā'ē.

— *at low water peninsula*, **H.** wēq'tlai's.

J.

jaw, lower, **H.** wunk'ēuqtē (= *edge of mouth*).

— *joint*, **H.** aqak'E'm.

blue Jay, **L.** ku'ckuc, **H.** koā'ēleqs.

joint, **H.** kqta (*notch* (?)).

juice of berries, **L.** saā'k', **H.** k'ōē-lē's.

to jump, **L. N.** tu'q'nit ; **N.** tu'qwu's, *to jump upon ground* ; tō'wīt, — *into house* ; tu'qsta, — *into water* ; tuq'tla'la, — *into fire* ; **H.** tqūā'lut, — *towards* ; tqtlā'lis, — *into fire* ; tqū'neqaut, — *along* ; tq'ōā'qa, — *down* ; tq'ō'tltsōa, — *out of* ; tq'sī'oa, — *through* ; tq'sō'stēoa, — *up* ; tqsta, — *into water* ; tqtsōa, — *into* ; **G.** tqū't ; tqtlā'lis, — *into fire* ; tqsta, *into water*.

— (*salmon*), **G.** t'ā'lema.

K.

to keep on, to continue, **N.** iā'la.

kelp, **L.** pāpōk'ōā'nim, **H.** wā'watē.

kettle, **N.** hanī'tl, — *on floor* ; ha'nūtllala, — *on fire* (—*utllala, fire*) ; **H. G.** gy'āntlalō'tatsē (—*atsē, receptacle*).

— *wooden*, **L.** k'ō'latsē (—*atsē, receptacle*), **H.** ky'etlā'tl, **G.** kyeba'tsē.

to kick, **L.** koa'c'it ; **H.** k'a'naqēit, — *with toes* ; tsē'qoit, — *with heels*.

killed, **N.** ky'ē'lagyuk'.

to kill, **H.** elq, tlatlala', **N.** halqa ; halai'ō, *means of killing* ; halq-siua'lis, *killing on land at mouth of river* ; ha'lq'ainoq, *murderer* ; ha'lqagyilak', *made to kill* ; halqubo'ē, *killing underneath*.

killer whale, **L. N. TI.** mā'q'ēnoq (= *knowing to pursue secretly*), **A.** ha'lqainoq, **H. G.** ha'lq'

ēnoq (= murderer); **H.** ha'lq'-ainō'quilak'oō, *killer kettle*; ha'lq'ailak', *painted killer whale*. kindly, **N.** ē'ikyala (= good noise; see *Happy*); k'ēk'ak'ā'lis, *a dance said to mean: every one kind to him*.

knife for cleaning skins, **L.** ky'auwai'ō, **H.** k'auwai'ō.

— *fish knife*, **H.** k'qtsem.

— *pocketknife*, **H.** qtai'ō, **G.** k'etk'tā.

— *large*, **L.** gy'ā'qōla, **G.** ts'u'tla.

— *of hawinolatl*, k'a'nlaiō.

— *stone knife*, **H.** nebai'ō.

knot on tree, **N.** k'ō'k'oa; k'ōk'oop'e'kyē, — *on lower part of tree* (= knot on shinbone; —p'ē'kyē, *shinbone*).

to know (see *To hear*), **L.** k'ā'tlam, **N.** k'ā'la; k'ā'lamōtl, *he — it*; k'ā'lak'olits, *the world knows*; **H.** k'ā'ō'tlnō'gua, *I know it*.

— *I do not know*, **H.** hō'ta.

knowing everything on earth (see *Story*), nū'qñemis (see *Wise*. *Name of the animals in myths*).

knuckle, **H.** ōk'oiā'.

L.

labret, **H.** k'a'tqtala (—qta, *mouth*).

lake, **L.** tsā'latl, **H.** g'ā'us.

lame, **H.** d'ē'mkoa.

lance, **N.** wī'tlpa (—pa, *point*).

land, **N.** —gyas, —lis, —gyilis, **H.** wa'q'nis.

to land, **L.** **H.** lā'gyilis (= *to go to land*), **L.** ā'tlēstēir quā'k'un, *the canoe lands*.

language (see *To speak*), **H.** k'ōm-hsiuakya'la, *white man's language* (*noise*); **G.** awī'kyala, *Gyil'amat language* = *correct noise*.

large, **L.** **N.** wa'las; wā'lasila, *to*

give fifty blankets to each in potlatch (= *to make large*); awō'gyōq, *large house*; **TL.** ō'mas; ōmatse'ms, *large house*; **G.** aō'mas, **H.** k'ē'kyas, k'aiē'kyas (= *really large, much*); k'ētsoa', *large water*; k'ēutla'li, *large fire*; **N.** k'ē'qtlala, *large fire*; k'aitlalatsē, *place of great fire*; (k'ē'kyēna, *many on drifting log*).

large, **N.** —tsē; gyō'ktsē, *large house*; gyig'ō'qtsē, *distr. large houses*; quā'quaku'natsē, *large canoes*; **K.** K'ō'titsē, *large one pointing to earth*.

last, **H.** walā'qtlē (—qtlē, *hind*) (see *Daughter*).

to laugh, **H.** dā'tlila; dātltsē'm, *laughter*; **G.** dā'tla.

I launch canoe, **L.** wī'qstēn q'quā'kun.

lazy, **N.** **L.** k'ā'msa; **L.** k'a'msēn, *I am —*; **K.** K'ā'msihtlē, — *on top*; **H.** kysk'ās.

to lead hamats'a around after Tsā'ēk'a, **N.** wā'lek'a.

leaf, **L.** paā'k'; paā'k'mis, *maple* (= *leaf tree*); **H.** mēmē'eqtlao, **G.** qā'k'um.

to learn, **N.** g'ā'gōtla; g'āg'ōtlā'numa, *I come to learn* (see *To hear*).

to leave, **L.** pā'ō.

left, **L.** k'ēm'qōtltsāna (—tsāna, *hand*), **H.** k'ēm'eqā'ot; k'ēm'eqā'otlha, *left side of body* (—na, *body*); **G.** ādzgyut (—gyut, *opposite*).

leg below knee, **N.** ō'p'ēkyē, —p'ēkyē; k'ōk'ooq'p'ēkyē, *swelling on shinbone*; **H.** k'ō'spēgya, tl'ē'tl'ēgya.

— *above knee*, **L.** ōnutsa'qstē (—nuts, *side*; —qstē, *bottom*), **H.** asā'nōtsēqtlē (—nōts, *side*;

- qtlē, *hind*), —tāmo; koak-tā'maluk, *having splint in leg*; k'uk'usqtā'mō, *skin of legs above knee*; **G.** kyukqōtā'moa, *knee*.
leggins, **H.** tē'telqts'oa; **G.** dzūdzuqtsī'tsa, *dancing* — (tsītsa, *foot*).
let us not! **N.** koā'lahīts.
lid of box, **N.** kok'ētayā'nō, gyī'seqstāl.
to lie down, **L.** kulī'tl (—ītl, *in house*); **H.** ka'lkuitl, *lying person*.
to lie down to sleep, **H.** la'htstātl (—ītl, *in house*).
to lie on back, **L.** netlē'tsō, **N.** d'ē'kyatla; **D'**ēikyā'la, *lying on back on sea*; d'ē'ih̄tlala, *lying on back in fire*.
to tell a lie, **N.** tlē'lkoala, **H.** k'ē'ik'us.
light, **N.** nā'k'ula; na'qnaikya, *day by day* (?); Naqnaaisilā'k'oa, *making the earth always lighted*; Na'qnaikyim, *making light*; naqnaais, *earth being always lighted*; nā'k'roatlāiō, *means of giving light*; Na'qnaikyimgyī'lak', *made light maker*.
to light fire, **L. H.** lek'uē'la.
light (not heavy), **H.** k'us.
lightning, **L.** tlēnē'quit, **G.** qu'lt-quata (see *Fire*).
lips, **H.** salī'qtē (—qtē, *mouth*).
liquid, **L.** iā'qa.
to listen, **N. H.** k'ā'watēla, **G.** k'ā'tēla (see *To hear*).
liver, **H.** tl'ēgyē's.
to load canoe, **L.** mā'wa, **N.** mō'qsēla (—qs, *in canoe*), **H.** la'qsut (—ut, *v. a.*), **G.** wā'meqsut; wā'mō-tlūt, *to unload* (—ōlt, *out of canoe*; —ūt *v. a.*).
to lock, **L.** īā'k'ēmt.
locked, **L.** k'ōē'tlk'ient.
log, **N.** t'ēna'ē (?); **H.** ya'k'ōē, *driftwood*; p'uqoai, *a log always drifting on same place*.
long, **L. N.** gyī'ltā; **N.** gyil'tā'la, — *river*; gyiltē'itl, — *house*; gyī'lsgyiltēm, *long-headed people*; **H. G.** gyilt.
 — *mouth of long shape*, **N.** ts'ē'k'atla.
 — *in composition with numerals*, **N. H. G.** —tsq.
long ago, **L. H.** k'aiū'tlutl; **H.** k'ai-ū'tlutl'ats, *in reference to invisible objects*.
to look, **L. N. H. G.** dō'quit; **N.** dō'p'ok'ala, — *among*; dō'quitla, — *into house*; dōqtsas-taitlēla, *he was —ing into house*; dōqsemaintlak, *I — after*; **H.** dōqōqtlā'la; — *back* (—qtla, *hind*; —la, *v.*); dōk'ōitlīla, — *into house*; dōk'ōaqala, — *down*; dōqsisstala, — *all around*; dōq-sōstēwala, — *up*; **G.** dumdu'k'qk'a, — *among*.
 — *up*, **L.** ēikyak'ē'muit (= *to make face up*), **G.** hā'tēla.
 — *down*, **L.** penk'ē'mhit (= *to make face down*).
 — *along*, **H.** koē'k'a (—k'a, *reaching towards*).
loan, **H.** bā'tla.
to lose, **H.** tēkō'sō't.
loud, **N.** hā'sēla (see *Council*), **H.** iā'ky'ēk'la (= *loud noise*).
louse, **L.** k'ēn, **H.** gā'ina.
to louse, **L.** k'u'tla.
low, **H.** ne'qwas.
low voice, **N.** aō'lak'ula; aō'lak'-oak'awasō, *the one speaking with lowest voice* (—k'awa, *extreme*; —sō, *participle*).
low, the lowest house of a row along river, **N.** gua'pē.
low water, **L.** ky'ā'ts'aias, **H.** tl'ō'palis.
lungs, **H.** qu'sa.
lynx, **K.** wā'lashe (= *large tooth*) (—she, *tooth*).

M.

- made of* — **N.** —tses; t'ē'sumtses, *made of stone.*
- to make*, **N. H.** —gyila; **N.** ō'ma-gyila, *to make chieftainness*; hē'iligyilik'aka, *always wanting to cure* (hēitl—, *right*); wā'num-gyila, *death*; ha'mgyila, *to feed*; le'wagyila, *heaven maker*; ha'lqagyilak', *made a murderer*; K'oe'gyilak', *made a whale*; T'ē'sumgyilak', *made stone*; k'oe'gyilisa, *to make something happen*; —ila; te'msila, *to beat time*; **H.** a'mgyila, *to cook*; —guila; gō'guila, *to make house*; wī'guilak', *painted eagle*; —ila; halq'aalak', *painted killer whale*; tlē'nuila, *to make mat*; **G.** gyū'guila, *to make house.*
- to make fire with fire drill*, **H.** sela'.
- man (homo)*, **N. H.** beguā'num; **N.** beg'u's, *man in woods*; baql ā'k', *eating human flesh*; baqbaku'l-atl, *always eating human flesh*; Baqbakuālanusī'waē, *always eating human flesh at mouth of river*; begyā'sit, *acidocer*; bā'guala, *to talk (man)*; bā'bakum, *youth*; **H.** beguā'numkyasō, *a real man*; bgua'la, *to talk (man)*; bgōpēs, *a talker.*
- man (vir)*, **H. G.** wē'sem; Bilqulā' s wē'sem, *a Bilqula man.*
- **ēnoq.** N. lāps'entaē'noq, *who knows to cut up.*
- many (see Much, Great, Large)*, **N.** k'ē'nem; k'ē'kyes, *eating much*; k'ak'ē'ky'ē'in, *I try to eat much*; k'ayē'nkui, *many in hand*; k'ai'tē, *many in him*; k'ē'kyēna, *many on a log of driftwood*; k'ai'uq, *precious*; **H.** k'ai'nem; k'ai'ntla'la, *much fire*; kykiē'i, *many things adrift*; k'ē'kyats, *large.*
- maple*, **L.** paā'k'mis (= *leaf tree*). *married*, **H.** hā'isk'.
- martin*, **L. N.** tle'k'ek', **Tl.** tlā'k'ik', **H.** me'stlk'an.
- martin blanket*, **N.** tle'k oqsem, **H.** mā'mastlk'ōtl.
- mask*, **L. N. H.** yi'qamt (yiq—, *dance*; —amtl, *head cover*); **H.** ha'lqamt, *killer whale mask* (ha'lqa, *to kill*); mī-i'uaē, *small wolf's mask for T'ōkoala, worn on head* (—iuaē, *forehead*); nau'alak' (*general term for dancing implements*).
- mast*, **L.** iau'apek', **H.** yai'uaspēk', **G.** yū'p'iq (*wind pole*).
- mat of bleached cedar bark*, **N.** gyī'tsus.
- *diagonal*, **L. N. G.** tlē'wē, **H.** tlē'oa; tlē'nuila, *to make mat.*
- *diagonal with black stripes*, **N.** tsā'tsaēuq.
- *for salmon*, **N.** yipelō'.
- *of bulrushes*, **N.** kulē'e.
- *strands parallel to rim*, **N.** tsā'kuitl.
- me*, **N.** gyā'qen.
- meat*, **L.** elts.
- medicine*, **L.** pātā'e. **H.** ē'qsa.
- to mend*, **N.** hai'atlila (= *to make right*); Hai'atlilak'as, *mending woman.*
- to meet*, **N.** kyi'mk'a (—k'a, *reaching towards*). **H.** bā'kō.
- to melt, ice melts*, **L.** yā'qētlā tlōq.
- menses*, **H.** ē'qenta.
- middle*, **N.** ā'k'aualis; nā'k'otlēua, *the — one*; nā'k'elta, — *on water*; nā'k'otlōoisēn s nā'la, *middle of sky*; nak'ō'yuitlē, — *in something on sea*; **L.** nak'ē'kiē, *midnight*; nek'ā'la, *noon*; **N.** gyū'iuē, *the middle one*; gyū'iuilis, *middle one of all*; ō'yūē, *the middle one in canoe*; nōlōyūēgyilis, *fool in middle of canoe on world.*

- midnight*, **L.** nak'ē'kiē (see *Middle*),
H. k'ā'ikya, **G.** k'ā'sk'amīya
 (k'ā'stisa, *noon*).
- mild*, **N.** iantlemē'tl, *made* — (*in
 song*).
- mill*, **H.** d'E'lyim.
- mink* (*Putorius vison*), **L. N.** metsa',
TI. H. kō'na, **G.** kunā'q; **N.**
 KHĒH, *in tales* (probably bor-
 rowed from the *Coast Salish*
 k'ā'iq); **N. K. TI.** name *in*
myths: tlē'selagyila, *sun maker*.
- to miss*, **L.** tlē'k'oa.
- monster in sea*, **L.** iā'kñim (= *cause
 of evil*), **H.** iā'kñis (= *evil in
 sea*).
- moon*, **L.** mū'k'ola, **A. H.** nō'si, **G.**
 gyīdzō'a; **A.** *in myths* Ky'ē'lō-
 yak'amē = *the first one*.
- morning*, **L.** nā'n'it (= *light*), **H.**
 wī'ōtl, k'oa'k'aa'la, **G.** na'q-
 k'oa.
- mortar*, **H.** mekoa'tsē (—atsē, *recep-
 tacle*).
- mosquito*, **H.** k'ā'ēqa.
- mother*, **L. N.** abe'mp, **H. G.** abō'uk,
N. L. āt (*said by children*), **H.**
 mā'ma (*said by children*).
- motion*, **N. H.** —nakula; **N.** mā'na-
 kula, *to swim* (= *fish motion*);
 K'ōmena'kula, *getting rich*;
H. lēina'kula, *to go toward*;
 tlāna'kula, *bark breaker*;
 k'ōkena'kula, *aze* (see *To here*);
 k'ēina'kula, *to go straight ahead*.
 — *to go far off moving*, k'nī'setla
 (see *Far*).
- mountain*, **L.** nī'kyē (*borrowed from
 Nootka* (?)), **A.** k'ōk's, **H.**
 g'ō'guis, **G.** wawē's.
 — *with snow on top*, **H.** nask'EM-
 ā'la (na'ē, *snow*; —sk'EM,
round thing).
- *goat*, **L.** me'lqtlō, **H. G.**
 ts'āk'; ts'ā'k'gyila, *where
 many* —.
- mountain kid*, **H.** mēmE'nīl.
- *blanket*, **L. N.** pelpelask'E'm,
H. ts'atsaqk'ā'utl.
- *tallow*, **N.** ia'sek'.
- mouse*, **N. L.** gyigya'tsk', **A.** tsā'mi,
H. askyā'nēk'qs (*female*).
- mouth*, **L. N. A. H. G.** sums; **N.**
 —qstē, tl'ē'tseqstē, *skin of* —
 (a'oaqstē, *mouth*); ak'aqstālis,
with open mouth on beach (ak'—,
open mouth); pe'nkyutaqstē,
chin (= *below opposite mouth*);
 tē'kuqsta, *carrying in mouth*;
 nā'laqstala, *carrying day in
 mouth*; k'amquaqstalis, *feath-
 ers in mouth on beach*; hā'paq-
 stēya, *beard*; ēkyut'eqstēn,
palate (= *above opposite mouth*);
H. —qtaē; hā'pqaē, *mus-
 tache*; sītqta'la, *a cod*; hasq-
 ta'la, *council*; saliq'ē, *lips*;
 k'atqta'la, *labret*; pō'qtaē,
oesophagus; qtlqta'ē, *pipe stem*;
 tl'ōqta'la, *sick at* —; agya'qtala,
to scold.
- open mouth*, **N.** ak'—; a'k'ētl, — *in
 house*; ak'aqstālis, *with open
 mouth on beach*.
- inside of mouth*, **L. N.** —ētlqā'oc;
N. tl'ētsētlqā'oc, *skin* —; wa'-
 pētlaqō'ya, *saliva*; **H.** tl'ōqoē-
 tlaqua'la, *sick* —.
- mouth of river*, **N.** ā'siwē; —sīwāē;
 hanhsī'wāē, *canoe at* —; gyō'q-
 sī'wāē, *house at* —; tliqsi'wāē,
clover root at —; tsūtsūpatsī'wāē,
river mouth dammed up; ha'lq-
 siualis, *killing on land at mouth
 of river*; **H.** K'ōmsiwa, *Eur-
 opean* (*rich at mouth of river*);
G. wastā's; gyūqtlis, *house
 at* —; **N.** kwā'k ēmatla, *facing
 mouth of river*; kwā'kyūtis,
*shorter one of two points at
 mouth of river* (*compare*: gua—,
north; guaḡē, *the lower one on*

river: —kyūt, *opposite*: —is, *land*).

to put into mouth, **N.** k'·a'sela; woqsem k'·a'sela, — *from both sides*.

mouth full of water, **N.** hamā'la (see *To eat*).

to move, change home, **N.** k'·ō'stis.

to move head while dancing, **N.** quā'nēk'a; gyē'sela (*in songs*.)

to move wildly, to boil (water), **N.** p'ō'iēqola.

murderer, **N.** kuē'qagyila (= *killling with club*); ky'ē'laky'ēnoq.

muskrat, kyilā'k'.

N.

nail of finger, **L. N. G.** ts'ē'mts'ēm, **H.** ts'ēmts'ē'mk'amē.

name, **N.** tlē'qk'am; tlē'k'ala, *to* —; tlatlik'ēlā'lait, *every one — s him*; ā'nkoaqtlas? *what is your* —? tlēk'atē'ntlas Nā'ntsē, *my name is Nā'ntsē*.

nape, **L.** ā'wapē, **H.** k'·oā'kukēnē.

narrow, **L.** amā'pitoq t'ē'uila, *narrow (small) road*.

navel, **L.** k'·etelō'k'ōitsē, **H.** pō'k'·tsē, **G.** pe'tsdzē.

near, **L. H.** neqoa'la.

nearly, ha'lsela —; ha'lsela'min wē'tsem, *I was nearly not in time*.

neck, **L.** k'·ō'k'·ōn; **N.** ōqtlāā'toē, *posterior part*; ōqā'oē; —qāōē, *anterior part*; **H.** k'·ok'·ō'nē; —qāōa; pētseqā'oa, *wind pipe*; k'·ōtsaqā'oa, *collar bone*; k'·ōk'·oqā'oa, *Adam's apple*; t'āk'·qā'oa, *neckring of bark*; tlō'·qoaqāola, — *is sick*; —skylene, — *posterior part*; tlō'qoaskyēnā'la, — *is sick*.

neckring of Hā'mats'a, **Tl.** tla'k'ak', **A.** k'·ā'lamōt.

needle, **L.** k'·ēnā'iō, **H.** k'·oā'qpa (—pa, *point*).

— *for macerating bark*, **A. H.** tl'akoā'nē.

nephew, **L. N.** tlōlē', **H.** tlō'ēl.

nest of bird, **H.** sīwa'tsē (—atsē, *receptacle*); k'·ēlqaila'tsē.

net (various kinds), **A.** tlakim, qā'·utem, **N.** gyigy'ē'tlem, **H.** yik'qk', k'·ōk'hoayai'ō.

nettles, **N.** ts'ē'tsenqtleM.

new, **L.** ā'tltsem.

news, **N.** ts'ē'tlwala (see *Famous*).

to nibble, **L.** k'·ēnī'ttsāō.

niece, **L. N.** tlōlē'k'as.

night, **L.** k'·ā'nutl, **H.** nēkk, **G.** g'ā'nūtl; **L.** nek'ē'kiē, *midnight*.

nine, **N. H. G.** mūwō's.

nineteen, **G.** mōuasgī'u.

ninety, **G.** mōpenkyāsk'ā'pōpena.

no [i, wī, ky'ē], **N.** wī, *not*; ky'ē, ky'ē'us, *no, none*; wī'lok', *none (obsolete)*; wī'ēmk'·asela'sōqtis, *with what he was not satisfied*; wī'k'·as, wī'k'·asela, *not to have enough*; wī'utl, *not to get what one wants*; wē'kyaē, *not quite full* (—kyaē, *top of box*); wī'tsem, *not in time*; wīō'sukuila, *making that there is no time to escape*; ia'qsum, *bad*; **H.** ky'ē, *no*; iakH, *bad*; **G.** wē'tlimas, *weak*.

it is not right, **N.** ō'tsatla.

noise, **N. H.** —ala; **N.** ba'quyala, *summer song* (ba'qus, *time when no ts'ētsā'ēk'a is held*); ts'ē'k'ala, *ts'ētsā'ēk'a song*; k'·ōē'k'·oqala, *raven's voice*; hā'sela, *loud*; kuā'kunq'ala, *council*; hauā'q'ala, *baton*; sa'oltala, *noise of falling objects*; tlēana'la, *noise of falling to pieces*; qē'nt'ala, *to snore*; de'nqēla, *to sing*; **H.** tlusa'la, *bad tempered*; tlō'qala, *to beat time*; hai'lala,

to scold; kē'q'ala, noise of saw;

G. Guē'tala, *Tsimshian language*; **H.** —k'oala; **N.** tsō'k'oala, noise of dancing apron; aō'lak'ula, low voice; gyō'qgyō-k'oala, noise of breaking; **H.** aikn'ēk'ula, good noise; **G.** Hēiltsa'k'oala, *Hēiltsuk language*; **N. H. G.** —kyala; **N.** hē'ikyala, noise; kumlēqkyala, noise; ts'ē'koikyala, voice of gull; hā'inakyalasō, hated; **H.** k'ōmūsiuakyala, white man's language; ky'ē'kyala, wooden trumpet; **G.** awi'kyala, correct language.

noise, **N. H.** ku'nqula; **N.** Ku'm-kumlēqa'tsē, name of rocks near Ft. Rupert = noise place; **H.** kunqlā'lis, noise place.

noon, **L.** nek'ā'la, **H.** k'ā'ek'ea, **G.** k'ā'stisa.

Nootka Sound tribe, **N.** Tsē'qltis'atq. north, **N.** gua'ē, gua'tsē; guaē'noq, northern tribe; **H.** atl'E1.

north wind, **TI.** qaiō'tl, **A.** yuyā'lanok'.

nose, **L.** ni'nts'as, **H.** hmāk, **G.** hūma'q, **N.** —itlpē; **L.** kwā'witlpē, perforation of septum; **N.** tl'ē'tsitlpē, skin of —; **H.** —itlpa; ū'itlpa, bill; tlōqōētlpē'lē, nose is sick; tle'nk'oitlpa, point of —; k'ōā'k'oiulpa, perforation of septum.

nose ornament, **TI.** kyū'kuis.

upper part of nose, **H.** ōwak'ā'ois.

nostril, **H.** ni'nts'as (see Nose).

not, **N.** ky'ē, **G.** ky'ū.

notch, **N.** k'aq; k'aqaq'tla', with two points; **H.** k'aqdē, notch of arrow.

novice in forest, **N.** gyi'egyila (= making chief); d'ē'k'ematla; tsē'tlela, — after his return from the forest.

O.

obsidian (?), **TI.** tsk'uls.

ocean, **N. H.** tl'ā'sak'; tsk'ē'noq, people of —; tlā'tlasik'oala, those on —; **L.** ā'owēkii, foam (?).

oesophagus, **H.** pō'qtaē (see Mouth). often, **N.** —pes; dōk'ulā'psentlak', I see him —; ts'ēqk'ā'pesen, I am — sick; —elk'; ts'ēqk'ē'lek'en, I am — sick (see Ex-
pert).

oil, **L.** k'ēls, **H.** tlē'na.

olachen, **N. H.** tsā'qun; **H.** tsā'quila, where — is always dried; **N.** ts'ē'mt'ek', half dry; wī'ōt'en. old man, **N.** k'ū'liak', **L.** nō'mas; **N.** Nōmase'nqēlis, the oldest on earth (—enq, edge); **H.** nō'mas.

old woman, **L. N. H.** tlekuā'nē.

old, **L.** k'ē'ōtl.

old (inanimate objects), **N.** k'ā'tla (see Long ago).

ō'mamis, name of a place.

on, (1) — long object, **N. G.** ō'kyena; **N.** k'ē'kyena, many on log; **G.** goā'kyena, to sit on long object.

— (2) — flat object, **N.** ō'tsuē; k'ā'seltsuē, to walk —; goā'tsoas, settie; **H.** ō'tsoa; tōtsoa', to walk over plank; goā'tsoa, to sit on plank; goā'tsāitl, to sit on bed in house; **G.** k'ā'tsoa, to walk on plank.

— (3) — round object, **N.** ōk'unē.

— (4) — a pile (on surface), **H.** —tlala; dlā'qolatlela, to stand on planks; goā'latlela, to sit on planks.

once, **L.** ne'mp'ana.

one, **N.** nemō'k'; NEMō'kuis, the only one; NEMō'kyustālis, the only one who came up out of ground; **H.** MEN; **G.** nōq; misk'em, one round object; mitsq, — long object; me'n-

Eq̄tla, — *cup*; mentsq, *twenty* (*one man*).

one another, **N. G.** —ap; **N.** mak'ā'p, *to throw* —; **G.** alqa'p, *to kill* —.

one eyed, **H.** k'oa'qstō.

only; **N.** ō'ma.

open, **N.** ak'—; ak'stā'la, *open box*; ak'ā'tla, *open mouth*; a'k'ētl, *open mouth in house*; aqstū't, *to open*.

opposite, **N.** —kyut; neqkyū'tis, *the one — outside*; neqkyū'ta, — *rocky place* (—a, *stone*); neqkyū'titl, — *in house*; kwakyū'tis, *the shorter one of two points at mouth of river*; **L.** pe'nkyutaqstē, *chin* (= *below opposite mouth*); ē'kyut'ēqstēn, *palate* (= *above opposite mouth*); hēitlkyuttsāna, *right hand* (= *right opposite hand*); K'ōmkyū'tis, *rich one opposite on land*; **H.** —kōt; hai'tlkoṭlna, *right side of body*; hai'tlkoṭkyanē, *right hand*; **G.** —kyut, ādzkyut, *left side*.

orator, **G.** ha'tleqteqs.

ornament of ear, **H.** mō'koato, *distr.* mu'mkoatō (— ato, *ear*; mōk, — *tied* (?)).

other side of, **L. N.** apsūt, —sūt; k'ō'sut, *far other side*.

otter, **L. Tl.** qu'mti, **H.** k'u'la; **G.** kutlsk'ē'qta; **H.** ky'ā'ma, — *young*.

overhanging, **N.** tlā'k'anuk.

our, **N.** sins.

outside, **N. H.** —ns, is; **N.** beg'u's, *man in forest*; aq'a'lkus, *blood on ground outside*; **H.** tlō'k'us, *country bare of plants*; **N. H.** — lis, els; **N.** tu'qwuls, *to jump upon ground outside*; kuī'nals, *to fall* —; d'ape'ls, *to flood ground*; **L.** lā'wils, *outside*;

tseqtsetk'oa'ls, *sicamp*; **H.** d'ō-k'olisēla, *to look out of house*; k'USE'ls, *wolf*.

out of, **L. N.** —ōtl; lō'otlto, *to go out of canoe*; k'ō'qoiltst, *to take off blanket*; **H.** —ōtlsoa; tqō'tlsoa, *to jump* —; sō'tltsōt, *to take out of box*; gyaq'ō'tlsoa, *to come — outside of house*, **H. G.** —aqsc; ts'ō'a'qscē, *heraldic column*; gō-a'qscē, *to sit* —; **G.** gō'qscē, *to sit* —; ky'ā'taqst, *to paint* —.

outside of whole body, **N.** ō'gwitaē.

outstretched legs, **N.** ilē'fis (= *Cormorant Island*).

over, **N.** —tlanē; k'ā'tsētlanē, *to walk over log*; **G.** —tlna; k'a'tlna, *to walk over log*.

owl, **H.** tttthnī.

P.

paddle, **L.** sīwā'io, **H.** g'āu'ma.

to paddle, **L. N.** sē'quit; **N.** hē'mēnatlēn sē'qoa, *I always* —; **H.** g'āu'sa.

pain ceases, **N.** ō'mat'ēt.

to paint, **L.** ky'ā'ta; ky'ā'taiō, *brush, pencil*; **H.** ky'ā'ta; ky'ā't'ēnoq, *painter*; ky'ā'taqst, *to paint outside of house*; ky'ā'tl-sēmt, *to — outside of house*; ky'ā'tgyōt, — *inside of box*.

paint, white for face, **L.** k'ue'q.

— *red for face*, **L.** k'ums, **H.** gums.

— *black for face*, **H.** ts'ō'tsetlēm.

palate, **L.** ē'kyutēqstēn (= *above opposite mouth*).

palm of hand, **H.** pāk 'atlkya'ne (—kyanē, *hand*).

panther, **L.** mamī's, **K.** betē', **H.** nāt'l'ai'a, **G.** mayā's.

parents of twins, **N.** yikwī'tl.

part of, **N.** —k'tis.

participle, **N.** —sō; —sue, *the one, who* —.

— *passive*, —k'; k'a'mgyik', *bitten*; hamañ'k', *eaten*.

parting of hair of woman, **L.** KH'ĉ'—nita; **H.** k'āqtpa'ls.

partridge, **L.** k'uku'm.

to pass by, to go past, **N.** lā'k'a (la—, *to go*; —k'a, *reaching toward*); ts'ĉ'k'oĉ, *passage*.

passage where travelers meet, **N.** ky'imk'it.

past, **N.** —tēis; quā'kunatēis, *broken canoe*; **H.** —ōltē; gyil'okō'tlĉ, *broken canoe*.

P'ā'tsis, *name of place*.

to pay, **L.** k'ō'na.

to peel off cedar bark, **L. A.** s'inga.

pelvis bone, **H.** kwā'kōleqtlē (—qtlē, *hind*).

pencil, **L.** ky'ā'taiō (= *painting instrument*).

penis, **N.** oqsak'ā'ōĉ; mōqsak'ā'ōĉ, *with tied* —.

people, **L.** bā'k'um, **H.** beguā'num; **N.** —ēnoq; Tlask'ĉ'noq, *people of ocean*; mā'q'ĉnoq, *pur-suing secretly*; **H.** ha'lq'ĉnoq, *murderer*; **H.** —itq, K'ō'k'aitq, Wiltē'tq.

perfect, real, **N.** aowī'la, *rough sea*; **G.** awī'kyala, *correct language*.

perforation, **N. H.** koa—; **L.** koa's-koanĉ, — *of ear*; koa'witlpē, — *of nose* (—itlpē, *nose*); **H.** koa'koathoa, — *of ears* (—athoa, *ear*); koa'koitlpa, — *of nose*.

pestle, **H.** mekoā'io.

pillow, **L.** k'ĉ'ī'nūtl, **H.** k'ai'nōtl.

pine, **L.** qā'qumis (—mis, *tree*), **A.** ā'nhit.

pipe, **L. H.** wā'q'atsĉ (= *smoke receptacle*), **G.** k'a'k'patsĉ (k'ak'pa, *smoke*).

pipe stem, **L.** tlā'noĉ, **H.** qtlqta'ĉ (—qta'ĉ, *mouth*).

to pity, **N.** waiatihiētla'soq, *I — him*; wā'iatigyilak', *not pity-ing any one*.

place, **N.** —lis; iuā'lis, *where always wind*.

— **N.** —us, as, —las; k'ĉ'us, *wash line (drying place)*; KH'ĉ'—tōkwas, *grassy* —; k'ō'lselas, *where always feasts are given*; sakwa's, *cutting place*; gy'ō'lō-tas, *porpoise place*; goā'tsoas, *settee (sitting on place)*; **H.** le-gni'las, *fire* —; alāea's, *grace-yard*; **G.** tl'ĉ'las, *store (selling place)*; ku'ilas, *bed (sleeping —)*.

— **N.** —at; ts'ĉ'kuat, *egg island*.

— **H.** —ĉles; tlēĉ'les, *store*.

— **H.** —ā'sĉ, tlq'ĉā'sĉ; hanĉa sĉ s gy'iloa, *place of canoes in woods*; gy'iloaia'sĉ, — *of canoes on beach*.

— **H.** —ĉnoq; koĉ'saĉnoq, *where always snow*; iōlaĉnoq, *where always wind*.

— *where always something happens*, — **TEMS**, **N.** k'ōā'iastems, *where always whales*; gyū'qtEMS, *village site*; k'ū'i'lastems, *feasting place*; bā'k'ōqtEMS, *fighting place*; **G.** —TEMA; gyū'qtEMA, *village site*.

to plait a braid, **L.** k'a'sk'ĉlqtlē, **H.** k'ā'tla.

platform of canoes, **H.** hā'wanak'k'. — *of house*, **L.** pā'ĉitl, **H.** ĉnsuaa-ī'tl (—itl, *in house*).

to play, **N.** a'mtla; hamā'tlāla, *women* —.

point, —pa; **N.** wī'tlpa, *lance*; Ts'ī'lkyempa, *feathers on top*; mō'mĉqpa, *white headed*; gua'pĉ, *lowest house on river*; mā'q'pĉ, *end*; awī'tlpē, — *of land*; ōpĉ, *point*; mā'tilpē, *point of Mā'taggyila*; aiñpa, *sharp* —; iĉ'ñpa,

dull (= bad point); k'ō'm-pigylis, richest in land; gyō'-k'opasila, house at point; ē'i-gyispalis, sand point; **H.** k'ō'm-pa-ut, to break off —; tE'nk'oitl-pa, point of nose; hā'ntlempa, — of arrow; goa'pa, to sit on —; sE'msempa, Sisiutl (= month at both ends); **G.** ssī'npa, sharp; paspe'luqpa, dull.

poison, **N.** wā'lagyila (in song = making people die), **A. H.** au'qsölē.

pole, —pek'; **N.** iau'apek', mast (= wind pole); sentlē'pek', flag staff; ts'ē'qpek', dancing pole; moqpek', heraldic column (= tie pole, — to which blankets are tied); ha'nspek', hamats'a pole; **H.** yai'uaspēk', mast (= wind pole).

pole for roasting salmon, **H.** tl'ō'm-sanō.

— of tent, **H.** tl'ā'qsem.

poor, **N.** wā'natlē.

porcupine, **N.** mē'hītē, **H.** nūt, **G.** nūlā'k'amē (= greatest fool).

porpoise, **N.** gy'ō'lōt; gy'ō'lōtas, — place; **H.** tl'ā'tlela, **G.** gyi'titl.

post of house, **L.** tlām, **H.** ts'ō'wīl (—itl, in house).

— carved, **H.** ts'itsoē'tl.

potato, **L.** k'ās.

potlatch. **L. N.** iā'k'oa; iā'k'ola, what is given in —; Hāaq'olā'tlemēk'a, woman always giving away presents in potlatch; hā'q-k'olatl, always distributing blankets; p'asa', to distribute blankets; p'asa'gyila, to make potlatch; p'ē'p'āyala, to promise to distribute blankets; mā'qoa (in songs), to give ten blankets to each guest; mā'qoagyila, to give a feast during which ten blankets are given each guest; mā'qola-

gyilis, mā'qsistā'lisa, to give ten blankets to each person of all tribes of the world; tlā'qōlēlem, to give feast during which twenty blankets are given to the opposite gens; wā'lasila (= to make great), to give feast during which fifty blankets are given to guests; la'qt'ūt, to give a feast to the opposite gens; la'qt'ōtpe, one who always —; mā'lē (obsolete), to distribute blankets; hamā'la gyilatl, always distributing blankets; amā'qut, to give away copperplates or other objects, a pile of objects; amā'qulatl, always giving —; **H.** iā'ha, potlatch; tlōola'qa, — dance; tlī-e'nq, time of —; **tl.** k'uitlā'qalus, potlatch.

potlatch, notice to friends that a potlatch will be given, **N.** tlē'lala, **H.** tlē'la.

— invitation to potlatch, **L. N.** tlē'la, **H.** tlē'tla.

power, **L.** ts'ō'laio.

to praise, **L.** ā'miaqa; ā'miaqēt, the one praised; **H.** k'antsamiqala-soē, God (= our praised one); **N.** tselō'k'a (see Famous).

precious, **N.** k'ā'iuq.

to pretend, **N.** —būtlā; hamā'būtlēn, I — to eat; mē'qabūtlēn, I — to sleep.

pretty, **N.** aikyā'ōē (= good forehead); **G.** aiku s beguā'num, a — man.

puffin, **H.** ōwī'tlpa (—itlpa, nose).

to pull, **L.** ku'ī'minūt.

to pull canoe into water, **L.** wī'quit, **H.** tluqstā'ūt (—sta, water; —ut, v. a.).

to pull out from among, **N.** neq'ak-ā'la (—ak'a, among).

to pull out hair, **L.** k'ulā'ō; k'ulā'ō, tongs.

pupil of eye, **L.** ts'ā'ts'olik'; **H.** bā'koanemstoa (= *man in eye*).
purpose, **N.** hē'numa; —numa;
 k'āk'otlā'numa, *I come to learn*,
to pursue, **L.** k'āk'ēnit.
 — *secretly*, **N.** mā'qa; mā'q'ēnoq,
killer whale (= *knowing to* —).
pus, **L.** tl'ōp.
to push canoe into water, **H.** tlqsta'ūt
 (—sta, *water*).
to push canoe ashore, **H.** tlqsiā'isa,
 tlqsiā'ūt.
to put, **N.** muqtsā'la, — *round thing*
into box (muq—, *round thing*;
 —tsā, *into*; —la, *v.*); muqwi'l-
 sēla, — *round thing outside on*
ground; seh'ātlts'ūt, ky'atsā'la,
 — *long thing into box*; leq'ā'tl-
 tsūt, *to* — *blanket into box*; **H.**
 gyētsoa'la, *something long that*
has been — *into box*.
to put on blanket, **N.** k'ōqtsā'la, **H.**
 k'ō'tih'it.
 — *hook into water*, **L.** ts'e'qstent.

Q.

Qā'ēqaas, *name of tribe*.
Qā'isla, *name of tribe*.
Qō'ēas, **N.** *name of extinct tribe*.
quail, **TL.** kui'lkau.
quartz, **A. N.** qū'ēla.
quick, **L.** hā'nakuē, **H.** hālakyelak's;
 hā'lakēla, *to work* —; hē'hala,
to walk —; i'ha, *fast*.
quiet, **N.** tenu'lk'oa'tla, ōmatatlā'la.
quilt, **H.** mākhia'.
quiver, **H.** hā'ntlematsē (= *arrow*
receptacle).
quotative, **N.** —lawē.

R.

raccoon, **L. TL. N. H.** mā'yus; *Nuq-*
nēmis name, māyusōstā'layilak';
A. kuē'k'qt.

rafters, **L.** pu'qbala, **H.** ōwau'tlt'a
 (*running from ridge to side*
walls), kaiiaa'us (*running length-*
wise, horizontally over the last
named).
rain, **L. H. G.** iū'koa; **H.** iūkuē'noq,
rainy country; iūkoaila, *it is*
raining.
rainbow, **L.** aai'htlala, **H.** mihsā'k'.
to raise, **L.** tlā'h'it.
herring rake, **L.** tletai'ō.
rapids, **L.** ts'ā'la.
rattle, **L. N. TL. H.** ia'ten; **N.** kuā'-
 qaten, *tlokoala rattle*.
raven, **L. N.** k'oa'wina; k'ōē'k'ua-
 qala, *raven's cry*; **H.** gō'ē, **G.**
 gā'aq; **N.** lē'labalis, *flying from*
one end of world to the other;
 le'wagyila, *heaven maker*.
to reach towards, **N. H.** —k'a; **N.**
 lā'k'a, *to go past*; k'ōā'k'a, *to*
surpass; kyim'k'a, *to meet*; **H.**
 koē'k'a, *to look along*; tse'k'a,
to throw toward; tsek'a'nut,
to throw at —.
to reach, **N.** k'ō'tis, *reaching to*
earth.
real, **N. H.** —kyas; **N.** gylēmkyas,
really feared; hē'meskyas,
real chief; beguā'numkyasō.
 — *man*; ku'nquakyasō. *what a*
thunder! **H.** k'ē'kyas, *large*.
receptacle, **L. N. H. G.** —atsē; **L.**
N. wā'qatsē, *pipe*; mena'tsē,
drum; nā'k'atsē, *bucket*; ts'ep-
 a'tsē, *small dish*; **N.** ā'watsē,
foam place; k'ō'latsē, *wooden*
kettle; **H.** hā'ntlematsē, *quiver*;
 sīwa'tsē, *nest*; k'ēlqaila'tsē,
nest; dā'dōk'ola'tsē, *armpits*;
 tē'qatsē, *bladder*; kh'ē'patsē,
large blanket basket; tēngua'tsē,
grease box; kh'ēlqēma'tsē,
white — *blanket box*; ōkwala'tsē,
woman's working box; mena'tsē,
drum; ts'epa'tsē, *dish*; gy'āntla

lō'tatsē, *kettle*; **G.** k'a'k'patsē, *pipe*; gyēba'tsē, *wooden kettle*; gy'ānthālō'tatsē, *kettle*.

to recover one's property, **N.** ē'toqa.
red, **L. N. H.** tlā'k'oa; **L.** tlā'k'oa-tač'ku, *evening sky*; tlā'qsem, *red blanket*; **H.** tlā'oqstō, — *blanket*; tlā'k'oēioa, *red cedar-bark head ring* (—ēioa, *fore-head*); tlak'qā'oa, *red cedar bark neck ring* (—qāoa, *neck*); tlā'k'ōtas, *alder*; **G.** tlā'qstō, *red blanket*; **L. N. A.** tlā'k'oa, *copper*.

relatives, **L.** tlā'la, **L. N.** nā'tlem-wiwut.

— **L. N. H.** —emp; gāge'mp, *grandfather*; negu'mp, *father-in-law*; **L. N.** ap'e'mp, *mother*; ōmp, *father*; gy'imp, *sister-in-law*; **H.** āu'mp, *father*; qtlemp, *uncle*; **G.** —ap; gaga'p, *grandfather*; āpf, *father*.

refuse, **H.** —āoa; hāmasā'oa, *rest of food*; k'ōk'oakā'oa, *chips* (= *refuse of chopping*); kēkēqā'oa, *sawdust*; —qtlēe (*hind part* (?)); ha'mts'aqtlē'e, *rest of food*.

to return, **L.** č'tsecta; **N.** k'antlogyiaqa'la, *when I return (old form)*; k'antlogyiaqē'tlētō (*new form*).

to take revenge, **L.** k'ēsē'tō.

rib, **L. N.** k'e'tem, **H.** hā'kya (—kya, *back* (?)).

rich, **N.** k'ā'yamala; k'ō'matlan, *I am* —; K'ō'mpigyilis, *richest on earth*; K'ō'mkyū'tis, *the richer one opposite*; K'ō'mk'ōm'kili'kya, *richest of all*; K'ō'mō'k'oa, *rich*; K'ō'mēna'kula, *getting rich*; K'ō'mōyuē, *rich one in middle*; **H.** K'ō'musiwa, *European (rich at mouth of river* (?)).

right, **N.** he'tlala, *it is* —; hē'ilkyut,

right side; hē'ilkyutlenū'tlemē, *right side of face*; hēitlā'lit, *to arrange bed*; hē'iligyila, *to cure*. *to mend*; hē'il'gya, *shaman*; **H.** hā'itlkōt, *right side*; hāilē'tlatl, *to cure*; hāilē'kya, *shaman*; **G.** hā'itlkyūt, *right side*; hāilikyala, *shaman*.

right, it is not right, **N.** ō'tsatla.

rim, **N. H.** ōč'sta (see *Around*).

— *hollow rim of lid of box*, **N.** hā'lek'.

to rise, **L.** lāq ai'kyēta kō'anila, *smoke rises* (= *goes up*); khaq-pā'tla it, *river* —; **N.** lā'tuse'lā'gyilis, *sun rises*; **A.** toatuse'lā'gyilis, *sun rises* (see *Down river*).

river, **N. H.** wa, **G.** wap (= *water*).

road, **L.** t'ē'nila; **G.** k'ā'tlōwa, *to walk on* —.

to roast salmon, **H.** tl'ō'pa; **L.** tl'ō'puk', *roasted salmon*.

robin, **N. Tl. H.** ku'tlem.

to rock cradle, **L.** tē'kula.

rock, **N.** —a; wī'nak'oa, *rocky place* (see *Stone*).

roe (unlaid), **L. H.** d'e'lgyim (**H.** k'u'te (?)).

— (*laid*), **H.** d'asō'k.

salmon roe, **L.** k'ē'nī, **H.** kai'nē.

to roll up a thing, **N.** lē'k'oa, **L.** kh'i'lhsem (to *wind a ball of string*).

roof, **L.** sōō'k'.

roof boards, **H.** hā'was.

roots, **N. L.** tl'ō'pikh, **H.** tl'ō'kum.

— *edible*, **L.** mō'taqsten, qā'tem (= *meč'n*, *Čatlōttq*), ts'ā'kyus; tlīqs'īm, *lover root*; **A.** qō'kum, *Indian rice*; t'ō'qsōts.

rope of seaweed, **H.** sā'nap'at.

rope, **L.** ts'ā'čqan, **H.** ts'ā'iq.

— *large, heavy*, **N.** ta'tuwīqotl.

— *of cedar bark*, **L.** mō'koanoč, **H.** milk'.

rope of skin, **H.** k'ō'tsē (see *Skin*).
 — *of spruce roots*, **L.** tl'ō'piku,
H. tl'ō'kum (see *Root*).
 — *of cedar twigs*, **L.** tlē'nakya.
rough sea, **N.** p'ō'lēk'olā'mas, *mak-*
ing sea rough; auwī'la; auwi-
 lakyitlanuk, *having rough weath-*
er and sea; **H.** tlā'qola.
to speak with rough voice, **N.** tlā'la-
 wulak'ula.
round, **L.** ki'lHSEM, **H.** lo'qSEM;
 lo'qSEMītl, *round thing on floor*;
N. mūk'ola, *moon* (= *round*
thing put down); pā'k'aqlēmō,
round thing is in box.
 — *outside of round thing*, —k'am,
 —k'EM, —SEM; **L.** pēak'E'muīt,
to look down (pēn—, *down*;
 —k'EM, *outside of round thing*,
face; —uīt, *v.*); ēikyak'E'muīt,
to look up; **N.** ō'sqEMē, *outside of*
round object; mamōsk'amEE'n-
 koa, *carrying four round ones*;
 Añtsumsk'amītl, *covered with*
haliotis in house; lō'sEMhit, *to*
uncover face; kuā'kuqSEM, *bis-*
cuit; **H.** nask'EMā'la, *moun-*
tain with snow on top; tā'k'umt,
to cover face; tl'ā'sk'am, *front*
of box; ō'sk'amē, *outside of*
round thing; ts'ē'koisk'EM,
wash bowl; goa'sk'amils, *to sit*
outside on round thing; tl'ō'q-
 SEMla, *mountain bare of plants*;
 qau'sEMt, *to wash canoe*; alHsi-
 mā'la, *blood on a round thing*.
to run, **N.** ts'aē'tlela, — *into house*;
H. gy'ēqsēsta'la, — *around*
 (—ista, *around*); gy'ē'qoalūt,
 — *towards*.
 — *river*, **N.** tsinā'la, **H.** tsē'HEla.

S.

sacred object, **N.** k'ā'mina.
sad, **L.** tsiqe'la nā'k'ōē (= *heart is*
sick).

sail, **L.** iā'oapEM, **H.** yai'uastEM;
 yai'uatsk, — *hoisted*; **G.** yai'-
 wadzEM (*from: wind*).
saliva, **L.** wa'pētlaqō'ya (= *water in*
mouth).
salmon, **H. G.** mēa'; **H.** mā'agyila,
where always salmon; **H. G.**
 mamē'a, *to catch* —; **H.** mamē'-
 asilas, *where always houses on*
beach for catching salmon; **N.**
 wā'wa, *salmon trap*.
 — *dog salmon*, **L.** k'ōā'qnis; **H.**
 goā'qanis.
 — *spring salmon*, **L.** sās's'EM, **H.**
 hai'sEN, **G.** k āps.
 — *cohoes salmon*, **TI.** tsawu'n, **G.**
 tsū'EN.
 — *sockeye salmon*, **N.** mē'tl'k'.
 — *sp.?* **TI.** hann'n; *sp?* **A.** tlo-
 qo'lamis.
 — *humpback salmon*, **N. G.** ky'-
 ā'pē.
 — *hooknose salmon*, **H.** was, **G.**
 huma'q'i.
to catch salmon, **L.** wā'yala.
salmon, split, **L.** t'ā'lek'.
 — *dried*, **L.** ky'ō'loq, **H.** qam'a's.
 — *roe, dried*, **H.** k'aknk.
salmon berry bush, **L.** k'cā'tlmis
 (—mis, *tree*).
salt, **L.** tEMSH; tE'mp'a, *salt taste*
 (—p'a, *taste*).
sand, **N.** ēiky'ēs (= *good beach*); ēi-
 gyispālis (see *Sea*), *sand point*
on beach; **G.** aigyitsuī's.
satisfied, **N.** mē'ntlē, **H.** pa'nk'la
 (see *Stout*).
to save, **N.** nā'la.
saw, **H.** kēqscy'ā'ō; kēq'ā'la, *noise*
of —; kēkēqā'oa, *sawdust*.
to say, **N.** nēkhsewē'tikh, *they —*
to me.
scalp, **H.** kunuqtlē'e.
scar, **L.** k'oa —; k'ōatē'oaē, — *on*
forehead; k'ōatsā'nē, — *on hand*;
 k'ōate'miga, — *on cheek*.

- to scold, **H.** agya'qtala (—qta, mouth).
- to scratch, **L.** tlā'qa, t'āt'i'qtsānak (—tsāna, hand).
- sea, **L. H.** temsq, **G.** demqs (?), **L.** aō'waky (foam (?)).
- in sea, —is; **N.** tsā'čk'is, secret in water; k'ā'mis, crab; **H.** ia'kuis, monster —; k'a'lkun-tsis, body on bottom of sea.
- on sea, **N.** —tlē; nak'ō'yuitlē, middle of something on sea.
- sea egg, large, **L.** mesē'k', **H.** ts'e'kuī'tsē.
- small, **L. Tl. H.** ā'mtem.
- seal, **L. N.** mē'kuat, dītr. mē'emkoat; mēmē'koatk', cating —; **A. H. G.** sāgu'm.
- young, **L.** khe'miastō, **H.** wu-lē'q.
- sealion, **L. N. G.** tlē'qčn, **H.** mau'akya; mau'akyaitem, sealion island.
- young, **H.** k'ta.
- sea monster, **H.** hā'nak'atsē (= canoe receptacle).
- sea otter, **N. H.** k'ā'sa; **N.** k'ā'sas-qem, — blanket; **H.** k'āk'ā'sōil, — blanket; **G.** a'ng'usta.
- young, **H.** tsī'sa.
- sea snail (holothuria), **Tl. H.** ā'las.
- sea weed, dried, **H.** tlk'ast.
- to search among, **H.** lē't'ak'a (—ak'a, among).
- secret, **N.** ts'ē'k'a.
- to see, **N.** dō'k'oala; d'ō'qtsas, seer (shaman seeing soul of dying person); **G.** dō'k'ula; **H.** d'ō'k'la.
- self torture ceremonial, **N.** hawinā'tl.
- to sell, **N.** la'qō'yō, la'qūt; laqōta'io, something sold.
- semiliquid, **L.** k'e'nkya.
- to send, **H.** ia'pa.
- settee, **N.** goā'tsoas (= sit in place).
- seven, **N.** ā'tlibū, **G.** matlō's; mase-mō's, — round objects; mats-k'ō's. — long objects; matlqltā'us, — cups.
- seventeen, **G.** matlā'sgūi.
- seventy, **G.** matlpenkyāsk'ā'pō-pena.
- to sew, **L.** k'ā'na; k'ā'naiō, thread; **H.** g'a'na; g'anama'las, thread.
- shadow, **L.** gyagū'mas.
- shaft of double headed harpoon, **H.** mā'siūt.
- to shake, v. a., **L.** iā'wiuelitl, qōā'yuseja, **N.** k'uā'yakula (—akula, motion (?)); nā'natlis, shaking his greatness (song).
- , **N.** —nila, —hula; yā'iawirila, yā'wiūila, shaking himself (host at tsētsā'čk'a).
- shaman, **N. Tl.** paqa'la, **L. N.** nau'alak', hē'ilikya (only when conjuring disease = mender), **H.** tsā'čk'a, hāilē'kya, **G.** hāilgyila.
- shame, **H.** mā'hts'a.
- shark, **H.** k'oa'k'oina.
- sharp, **L.** ā'ihpa (= good point), **G.** ssi'ihpa.
- to sharpen, **L.** t'ē'h'it.
- sheets, **L.** wā'taiō, **H.** k'ō'k'očgya (—čgya, back).
- shellfish, **H.** kyāōč'kam.
- shinbone, **N.** —p'čkyč, ō'p'čkyč; k'ōk'ōq'p'č'kyč, knot on lower part of tree (see Leg below knee).
- shirt, **L.** k'ēsēnā'č.
- shoe, **L.** t'ē'paiō, **H.** k'ē'naq.
- to shoot, **L.** hā'ntlitl, **G.** hā'ntla; hā'ntlem, arrow gun.
- shore, far from —, **L.** tlā'tlasatl (see Ocean).
- to go close to shore, **L.** lā'gyilis (= to go landward).
- short, **N.** tse'kua; tsekuā'la, short river; ts'ē'tsakūila, to shorten life; **L.** tsekue'qst, a — man;

tsu'qpitū, *short* (—pitū, *small*):
H. ts'EK'; qā'pHō, *a — man* ;
N. nemā'lis, *short lived*
shoulder, L. tlā'stalē, **H. G.** ō'quīna.
shoulder-blade, L. pā'lōts, **H.** tlā'k'-
 oTEN.
to show one's teeth, L. hī's'it.
to shred cedar bark, A. tsqa.
a shrew, H. thsela'k's (k's, *woman*).
to shut door, L. kh'E'mihit.
sick, N. L. ts'ē'nīla; ts'ē'nīla nā'k'ōē,
heart sick = sad; ts'ē'nā'tōla.
ear is —; ts'ihtsāla, *headache*
 (= *sick inside*); ts'E'qk'an hē-
 menatlama, *I am continually*
sick: ts'E'qk'E'lken, ts'E'qk'ā'-
 pESEN, *I am often sick*; **H.**
 t'ōqoa'la; t'ōqoa'la, *ear*
is —; t'ōqoēt'laqau'alē, *mouth*
inside —; t'ōqk'ca'lē, *head —*;
 t'ōqoēt'pē'lē, *nose —*; t'ōqo-
 ma'lē, *face —*; t'ōqstoa'lē,
eye —; t'ōqoaqā'ola, *throat —*;
 t'ōqoaskyenā'la, *neck near*
nape —; t'ōqēioa'la, *forehead —*;
 t'ōqoaqtalā'ēla, *inside belly —*;
 t'ōqoapō'ala, *on chest —*; t'ōqo-
 ala'so, *in chest —*; t'ōqta'la,
mouth —; t'ōqoana'la, *all*
over —; t'ōqoa'la s gyi'lem,
tongue —; **G.** ia'kh.
sick eye, N. g'ōgumē'k'ENō.
side of a thing, ō'nutsē; ā'tlanutsē,
one behind the other; **H.** asā'-
 nōtseqtlē, *leg above knee (side of*
hind part).
 — **N.** ōnutlemāla; hēilkyōtlenū-
 tlemē, *right side of face*; guā'-
 nutlemē, *sitting at side of —*;
 gyōgyokōnutlemala, *house on*
each side of —; gyō'gykōnutlem-
 ala, *something — —*.
side of a flat thing = edge, H.
 ōnaqé'.
sinew, L. H. ad'E'm.
to sing for pleasure, L. sālala, **H.**

nē'nōya, **G.** hā'na; ha'nqto'a,
 — *while walking*.
to sing to dance, N. de'nqela, **L.**
 k'E'mTEN (?).
singing master, N. nā'k'at, dā'k'ola,
H. hā'hts'as, *distr.* haiā'hts'as ;
the three assistants of singing master,
N. guā'nutlemē (= *sitting at*
side).
to sink angle, L. ts'E'qstenta k'ē'taiō.
river sinks, L. kyō'tla.
Sindlaē, N. *ancestor of a gens*; sin-
 tlē'kam, *face of —*; sintlē'pek',
flagstaff.
sinus of hair, H. tsī'kye.
S'isutl, fabulous double-headed
snake, N. H. sī'siūt, **H.** se'm-
 semspa (= *mouth at each end*).
sister calls sister, L. N. nemē'mak'as
 (—k'as, *woman*), **H.** menū'-
 yak's (—k's, *woman*).
sister, elder, L. N. H. G. nō'la.
 — *younger, L. N. H. G.* ts'ā'ya.
brother calls sister, L. N. H. G. wa'-
 k'oa.
sister-in-law, N. H. gy'imp.
to sit, N. H. G. goa—; **N.** goa'qsala,
 — *in canoe*; goā'goagyilitl, — *in*
middle of house; goā'nē, — *in*
corner of house; goā'goagilēlas,
sitting down in house without
back support; goā'tsaos, *settee*;
 goā'nutlemē, *sitting along side*;
H. goā'tsāitl, — *on bed*; goa'-
 sk'amitl, — *inside a thing*;
 goagoa'k'itl, — *on top of*; goa'-
 tsoa, — *on flat thing*; goā'latla,
to sit on planks; g'ā'latlēla, *sit-*
ting down on chair, on planks;
 goa'qtoa, — *on top, point of a*
thing; goā'pa, — *on point,*
front end; goala', — *on stone*;
 goā'gyena, — *on long thing*;
 goaū'ioa, — *on point of a thing*;
 goa'qtlaē, — *on hind end*; go-
 a'qtis, — *on beach*; goa'sk'am-

- ils, — *on round thing outside* ; goa'luqlēas, — *on roof* ; goā'qs, — *in canoe* ; goa'itēma, *settee* ; goa'qsē, — *outside of house* ; **G.** goa'itl, — *in house* ; goa'qtoa, — *on top of, on point* ; goa'kyena, — *on long object* ; goa'sk'am s t'ē'sem, — *on stone* ; goa'itlō-wa, — *under cover*.
- six, **G.** k'ētlō'q ; k'ētla'sk'em, — *round ones* ; k'ētla'tsq, — *long ones* ; k'ētla'iqta, — *cups*.
- sixteen, **G.** k'a'tlagin.
- sixty, **G.** k'atlapenk'ā'pōpēna.
- skates, **H.** gau'm.
- skillful boatbuilder, **H.** ā'tl'eskiō.
- skin, **L. N.** tl'ēs ; tl'ē'siapē, — *of upper part of arm* ; tl'ē'tsēpoē, — *of chest* ; tl'ē'tseqtlē, — *of crown of head* ; tl'ē'semē, — *of face* ; tl'ē'tsitlpē, — *of nose* ; tl'ēsī'nē, — *of forehead* ; tl'ē'tsanē, — *of hand* ; tl'ē'tsētlqā'oē, — *of inside of mouth* ; tl'ē'tseqstē, — *of mouth* ; **H.** k'u'tse ; k'uk'uskyā'nē, — *of hands* ; k'utsemē'kyē, — *of back* ; k'u'smē, — *of face* ; k'utsikyatlkyā'nē, — *of back of hand* ; k'uk'ut-sēā'pē, — *of upper part of arms* ; k'uk'usqtā'mō, — *of legs above knee* ; k'utsēpō'a, — *of chest* ; k'uk'utsī'tsa, — *of feet* ; **N.** k'utā'otl, *skin blanket* ; **G.** tl'ēs. — *of heels*, **H.** amea'tltsitsē.
- to skin, **L.** sā'p'a.
- skull, **L.** qā'uik'.
- skunk, **H.** ia'qp'ala (= *bad smell*).
- sky, **N.** lō'ua, nā'la ; nēnā'lanuk, *changing (having) weather* ; **H.** lewa'.
- slabs of wood sewed to hand of hawin-all, **N.** sē'quitēm.
- slave, **L. N.** k'ā'kyū, **H.** k'ā'kō, **G.** k'ā'nō ; **N.** k'ak'akuistā'lista, *making slaves all around* ; slave, a whole tribe enslaved, **N.** ē'iatl-ela (*in song*).
- to sleep, **L. N.** mē'q'it ; mēqabū'tlēm, *I pretend to —* ; ky'ē'sen mē'q'ēqsta, *I do not want to —* ; **H.** gy'ā'tla ; gy'atlē'qstē, *wanting to —* ; **G.** ku'l'itl ; ku'l'ilas, *bed*.
- sling, **TL.** ye'nkn'aiō.
- slow, **L.** ōya ; **H. G.** wē'hala (= *not fast*), *to walk —* ; auā'kya, *to work —*.
- small, **N. L.** amā'e ; ama'enqē, *smallest* (= *edge of small*) ; amā'pitō, *small* ; amamēnēn'q, *small things* (= *mēnēq, small distr.*).
- *s.*, — *pitō* ; **N.** tsuqpitō, *short* ; gyōkpitū, — *house*.
- *distr.*, — *mēnēq* ; **N.** gyōkmenēn'q, — *houses* ; quākunamēn'q, — *boats*.
- smallest, — *enqē* (= *edge*) ; ama'enqē, *smallest* ; ts'ētsēqk'ē'nqē, — *dancers*.
- smallpox, **N.** tēma'c (= *boil*), ia'knim (*cause of evil*).
- to smell, **L.** mē'sela ; **N.** ai'np'ala, *good —* ; **H.** ai'np'ala is wē'sum, *good smelling man* ; ia'np'ala, *skunk* (= *bad smell*) ; ua'qp'ala, — *of smoke* ; **G.** hu'mk'ata.
- smoke, **L. N.** koanī'la ; Kua'itanō'kumē, *who has most smoke* (*i. e.*, *always giving feasts*) ; **H.** ua'qela ; ua'qpis, *smoker* ; ua'qp'ala, *smell of —* ; uaqoaqtoa, *smoking in walking* ; uaqoaq-ā'qtis, *smoking on beach* ; uaqa'tsē, *pipe* ; **G.** k'ak'pa, *to smoke* ; k'ak'paqtoa, — *in walking* ; k'ak'patsē, *pipe*.
- *hole*, **L.** qsātla, **H.** waqa'wa. smooth ; **N.** k'ē'tsila, — *beach* ; k'ē'tsitl, — *house floor*.
- snail, **L.** k'ōā'ts'ek', **H.** k'ōā'tas.
- snake, **L. N.** sē'itlēm ; sē'ilis, — *in*

- belly*; **H.** sī'tlēm, **G.** k'a'k'el-k'oa.
- to sneeze*, **L.** asī'isit.
- to snore*, **L.** qe'nt'āla.
- to snow*, **L. H. G.** k'uē'sa; **H.** k'uē'-sainoq, *where it is always snowing.*
- snow (on ground)*, **L. G.** nē'e, **H.** nā'ē; **nask'emā'la**, *mountain with snow on top.*
- soft*, **L.** telk'.
- sole of foot*, **H.** t'ē'pēm.
- solemn*, **N.** beku'm; **Bē'bekumlisila**, *making solemn in house.*
- something in eye*, **N.** gyistō'ē.
- son (see Child)*, **H.** hāu'itsē, *only* —; **wala'qtlē**, *youngest* — (—qtlē, *hind*); **nō'lak'amē**, *eldest* —; **g'au'ioa**, *second* —.
- *chief's eldest son*, **N.** tlēō'le-k'amē.
- son-in-law*, **L.** nequ'mp.
- song*, **N.** ts'ē'k'ala, *winter song* (= **Tsētsā'ēk'a**, *noise*); **baquyala**, *summer song* (= **Ba'qus noise**); **k'a'mtēm**; **tsā'qatla**, — *in quick measure.*
- soring*, **N.** k'anā'tla.
- sorcery (see To bewitch).*
- soul*, **N.** begua'ē, **beq'una'ē** (**beg—**, *man*).
- sour*, **N.** sā'k'a, **H.** ts'ē'qp'a (—p'a, *taste*).
- span*, **L.** pātł, **H.** ōp'e'nkh.
- spark*, **L.** anopē'q'it, **H.** pē'gyak'ala.
- *spark spirits*, **N.** menak'itł.
- *to emit sparks*, **L.** tle'msa.
- sparrowhawk*, **H.** t'ih'tēgus.
- to speak, male*, **N.** bā'guala, **H. G.** bgu'a'la (= *man's noise*); **bgō'pēs**, *good speaker.*
- , *female*, **N. G.** k'ā'kyala, **H.** k'kyala (= *woman's noise*); **k'kyapēs**, *good speaker.*
- **N.** iā'k'antal; **iā'k'ēgyatlēla**, *to deliver oration*; **iā'k'antēnoq**, *orator.*
- to speak with rough voice*, **N.** tlā'la-wulak'ula.
- *good of one*, **N.** ai'hp'aqsta (**aiH**, *good*; —p'a, *taste*; —qsta, *mouth* (?)); **iā'qp'aqsta**, *to — bad of one.*
- **N.** hā'sak'awasuē, *trying to speak loud*; **ēiwa'la**, *to speak about one's wishes (song).*
- to spear*, **L.** sēkya'.
- spider*, **L.** y'k'a, **A. H.** hāuma'qa.
- spike (of spruce, etc.)*, **A.** kh'ā'mamō, **H.** mamē'em.
- to spin*, **L.** mē'ta, **N.** k'emk'ā'.
- spindle*, **N.** ni'lp'aqstō.
- to spit*, **L.** ku'c'it.
- to split*, **N.** kuē'q'it, **kuā'qsant.**
- *wood*, **N.** tle'mh'it, **H.** koā'k'—; **koak'tā'maluk**, *splint in thigh.*
- *canoe splits*, **N.** hō'uqoa.
- *cedar bark*, **L.** pe'q'it, **A.** pā'sa.
- *salmon*, **L.** t'ā'lēk', **H.** ky'ē'a.
- spoon*, **N.** ts'ē'qta, *large* —; **H.** g'ōtai'ō, — *made of mountain goat*; **ky'ā'tsenak'**; **tsyā'laiō**, *large* —; **G.** hamdsai'ō (= *eating instrument*).
- spring of water*, **L.** ts'ē'thēla.
- *of year*, **H. G.** wīā'gyiōa.
- to spudder*, **L.** tseō'quit.
- squid*, **N.** t'a'k'oa; **k'ak'ō'mis**, — *in cheek*; **t'ā'ēk'ōtl**, *where squids are eaten*; **H.** tk'oa.
- *sp. (?)*, **N.** ky'i'nut.
- squirrel*, **L.** tamī'nas, **tl.** māł, **H.** tsā'mi.
- to stand up*, **N.** dlā'uis; **dlask'amā'tlin**, *I — facing sea*; **dlā'witł**, — *in house*; **dlā'qoē**, *proper place of each gens in feast*; **H.** dlaa'u's, — *outside*; **dlā'qolatlēla**, — *on top of a long thing*; **dlā'auwitł**, — *in house.*
- to stay at home*, **N.** nek'a'; **nek'ē's**, *always* —; **Nak'ō'mgyilisila**, *always staying in their own country.*

- star*, **L.** t'ō't'ō ; amā'qemis is t'ō't'ō, *shooting* —; **H.** t'ō'tōa, **G.** nīnik'edzō'a.
- starfish*, **L. N.** k'ātsk'.
- steady*, **L.** t'ā'aq.
- to steal*, **N. L.** gyilō'tla ; **L.** gyilō'tlik ; *thief*; **N.** gyilō'tlē, — *on sea*.
- steamer*, **N.** hō'k'ayala, **H.** qu'tlēala (= *fire inside*).
- to steer*, **H.** tlā'lanila ; **L.** tlih'it, — *canoe, pressing paddle from canoe* ; tlō'k'umH, — *pressing paddle towards canoe*.
- stem of canoe*, **L.** ā'kyiūc.
- to step on something*, **N.** t'ē'patla.
- stepchild*, **L.** k'oa'o (?) , **N.** wawa.
- stepmother*, **H.** ā'patsō.
- stern of canoe*, **L. N.** ō'qtlē (= *hind part*).
- stick for spreading salmon*, **H.** tlā'qem.
- "*stick shoe*," **N.** k'ā'k'anās.
- stomach*, **L.** nā'k'apoč, **H.** pō'qums.
- stone*, **L. N. H. G.** t'ē'sum ; **N.** t'ē'sumtses, *made of* — ; t'ē'sumgyilak', *made* —.
- **N. H.** —a ; **N.** neqkyū'ta, *opposite rocky place* ; kyā'k'a, *found on stone* ; nemō'k'oa, *alone on rock* ; wī'nakua, *rocky place* ; **H.** goala', *to sit on* —.
- to stop a water course*, **N.** tsū'pa ; tsūtsūpatsi'waē, *stopped mouth of river*.
- store*, **H.** tlēāē'les (= *buying house*) ; tlē'ilks, *storekeeper* ; **G.** tl'ē'las, tl'ē'lgis, *storekeeper*.
- stores of dry salmon*, **L.** hēitlē'laiō.
- story*, **N.** nū'yam, *distr.*, nū'nim ; nū'qnemis, *name of all animals in myths*.
- stout*, **L.** pentlē'is.
- straight*, **L. N.** nek'a'la ; nek ā'qala, *slow measure rhythm* (= *straight down*) ; **H.** k'ē'inakula, *straight ahead* ; **N.** hayim (*in song*).
- strait*, **H.** wunā't'hus.
- strap of basket*, **L.** k'ā'tlin, **H.** tena'qōtl.
- to strike with fist*, **N.** miu'it ; miu-stēk'ē'mt, — *face* ; miu'ikyent, — *back* ; mi'nīla, *drummer* ; **H.** mēma' ; miuptā'ut, *to bend by striking with fist* ; **G.** miu'lis, *drummer*.
- *against*, **N.** t'ih'ā'tlēla.
- **H.** a'lqa, **G.** alqa ; alqā'p, — *one another*.
- *with palm*, **H.** tlā'sa.
- *a dog*, **H.** watsē'la.
- *with hammer*, **H.** mōkoa' (see *To bend*).
- strong*, **L. N.** tlō'k'uimis ; tlō'kum, *cause of strength* ; **G.** tlōq.
- sturgeon*, **TI.** hā'nak'ois, **H.** k'ā'is.
- to suck*, **H.** tsā'ma ; tsā'mamis, *to suckle*.
- sugar*, **L.** ē'kyisilā.
- summer*, **L.** hē'ianq, **H. G.** hāi'nq (— anq, *time of*).
- sun*, **L.** tlē'sela, **N.** ā'ta, — *as deity* ; **H. G.** tlē'hsioala.
- sunrise*, **N.** tōatuselagyilis ; **H.** latuselagyilis (= *goes down river on earth*) ; **G.** k'ēkyō'ia.
- sunset*, **L.** lā'pēta, **G.** lā'is.
- superlative*, **L. N. H. G.** —k'amē ; **N.** i'hak'amē, *fastest* ; gyē'k'amē, *greatest chief* ; nō'lok'ēmaē, *greatest fool* ; nō'lasnek'ēmaē, *eldest child* ; nemō'k'oa-k'amē, *all alone on rock* ; **H.** nō'lak'amē, *eldest child*.
- supernatural*, **N. H.** tlōkoa'la.
- to support*, **N.** tlā'tēla (= *to make stand*) ; tlā'lamin, *supporter*.
- surface of sea*, **N. H.** —tlē ; dlas-k'amā'tlin, *I stand facing sea* ; gyilō'tlē, *to steal on sea* ; tlatlasik ō'tlikH, *here is a canoe with Tlatlasik'oulu* (—KH, *present* ; —tlē, *on sea*) ; **H.** k'auk'ouase-

la'k-tle, *canoe drifting to and fro*; mā'tlēla, *to swim*; **G.** hanēilwa'paqē, *canoe on water.*

to surpass, **N.** k'ā'k'a.

to swallow, **N.** nek'olā'laqōm; nek'·E'k', *swallowed* (= *eclipse of sun*); **H.** k'·u'nquit.

swamp, **L.** tseqtsek'oa'ls (—als, *outside*), na'hila.

sweat, **N.** k'ō'sa; **H.** k'ō'hpis, *sweating*.

to sweep, **H.** ky'ē'tla.

sweet, **L.** **TL.** aihp'a (= *good taste*). *sweetheart*, **L.** wā'tela.

when always high swell, **H.** t'ō'qelis.

to swim, **N.** mā; **L.** mā'nakula (= *fish motion*); **L.** te'msēlaiō (?); **H.** mā'tlela (*nan*, = *swimming on surface*); mamā'lama, *children trying to swim*; **H.** k'ola'la (*fish*), **G.** k'ōā'la (*fish*).

T.

tail of quadruped, **L.** hats'E'qstēe (—qstē, *bottom*), **H.** ha'ts'iqtē (—qtē, *bottom*); **N.** nū'naqstē, — *of wolf* (= *wolf's end*).

— *of bird*, **H.** nā'kyaqtlāc (—qtlāc, *hind*).

— *of fish*, **L.** ts'ā'snē, **H.** ts'anē't.

— *of whale*, **H.** t'ēk'aqtē'; *white tailed fox*, mō'k'·uqt (= *white tailed*); **A.** kuē'qt, *raccoon*.

to take, **N.** āq'ē't.

tall, **L.** gyi'lteqst (gyi'la, — *long*), **H.** noā'kila.

tallow, **N.** k'ā'tsek; **H.** tl'ā'tai, gō'luk', — *of mountain goat*.

taste, **N.** **H.** —p'a; **G.** **N.** aihp'a, *sweet*; **L.** te'mp'a, *salt*; **H.** ts'ē'qp'a, *sour* —.

tear, **L.** koā'kuistoē; tsē'tsāokula, *to weep*.

to tease, **N.** mē'itla.

to tell, **L.** nē'tlasō; — *myths*, **N.** nō'sa.

temples, pelnūtlemā'ē (= *thin side of face*), **H.** pā'spelē' (see *Ear*).

ten, **G.** k'·ā'pō; k'·ā'p'usk'em, — *round ones*; k'·ē'putsq, — *long ones*; k'āpō s beguā'num, *two hundred*.

thick, **L.** wōk.

thief, **L.** gyil'ō'tlik'.

thin, **L.** pe'lpitō (—pitō, *small*); k'ā'tläis (*person*).

things lying about, **L.** t'ā't'its, **H.** mamē'kyas.

to think, **L.** gyē'gyēk'a.

thirsty, **L.** nā'k'·ēqst (= *wanting to drink*), **H.** tsō'sētliqa (= *dry mouth*), **G.** tsō'sems, nā'k'abū.

thirteen, **G.** yūduqgīū.

thirty, **G.** yūduqpenk'·ā'pōpēna.

thorn, **N.** k'·ā'k'anē.

thou, **L.** **N.** sō'wa, yūtl; **H.** k'qsō, k'qsoā'ēoa; **G.** yi'qsō.

thread, **L.** k'·ā'naiō (= *sewing instrument*), **H.** g'a'nema'las.

three, **G.** yūdu'q; yūdu'qsem, — *round ones*; yūdū'tsq, — *long ones*.

thrice, **N.** yū'duqp'ana.

throat, **H.** k'·u'nkoas (see *Neck*).

through, **H.**—sioa; tqsi'oa, *to jump* —; laqsī'oa, *to go* —; maqsō't, *to throw* —.

to throw, **N.** mā'k'a; mak'·ā'p, — *one another*; mak'·ā'io, *stick of shaman for throwing* (—ing, *instrument*), mā'mak'a, *trying to* —; maq'ē't, *to drop*; **H.** maqsū't, *to* — *through*; maqsō'stūt, — *up*; maqlā'lisa, — *into fire*; mā'k'·ak'a, — *among*; mak'a'neqant, — *along*; ma'qautlts'ōt, — *out of*; ma'qtsōt, — *into*; mak'a'qōt, — *down*; **G.** mā'quitt.

— *into canoe*, **N.** lek'yá's; lā'la-kyutsē, *throwing every one into canoe*.

to throw, "to throw song out of canoe,"
k'amt'Emō'tltūt (k'ā'mtEM,
song; —ōtlt, out of canoe; —ut,
v. a.), (i. e., a singer in the
canoe which goes to a feast greets
the host with a song).

— into water, **H.** nuē'tltaut (man,
animal), ts'aqsta'ūt (a stone,
—sta, water).

to throw, **H.** ts'ek'anu't, — towards;
ts'aqsiaa'lsa, — ashore; ts'Eqā'-
lilila, — into house.

to throw copper, paddle, board (flat
objects (?)) into house, **N.** sepā-
alilēla.

thumb, **L. N.** k'ō'ma, **H.** k'ō'na, **G.**
k'auna'; **H.** kōna'hsitsē, big toe
(—hsitsē, foot).

thunder, **N.** ku'niqua; ku'nuatēla,
noise of —; ku'nquakyasō, what
a —! **G.** lu'qlisla.

thunderbird, **L. N.** Kunkunqulī'kya,
N. ts'ō'na; ku'n'ōas, home of —.

tide (current), **H.** ts'ā'la.

to tie, **N.** mōq; mō'qpek', heraldic
column (pole to which [blankets]
are tied), **L.** mō'quit; **N.** mōq-
sak'ā'o, with tied penis; **G.**
muk.

time of, —Enq; **L.** hē'ianq, summer;
tsāwu'nq, winter; **H.** tlīē'nq,
potatch; hāi'nq, summer; tsā-
wu'nq, winter; **G.** hāinq, sum-
mer; tsōnq, winter.

— to be on time, **N.** hū'ilts'a (see
Right); wī'ts'a, not on time;
nīō'sukuila, making that there is
no time to escape.

tired, **N.** mā'mentlēas, making
him —; me'nl'ēt, tired of eat-
ing certain things; **H.** tlā'lasō.

Tumē'latsē, **N.** house in which tse-
tsā'ēk'a is held.

tobacco, **L. N. H.** tlā'uk'.

to-day, **L.** qoanā'laq, **H.** goa'k'ēla-
ioq.

toes, **N.** k'ōā'k'ōasitsē (—sitsē, foot),
H. k'ōā'k'ōansitsē (—hsitsē,
foot).

— big toe, **H.** k'onā'hsitsē,
(= thumb of foot).

together, **N.** k'apē'; k'ā'pēgatl
gyā'qEN, they will come together
to me; k'ā'pēgawāstlis, they
will come together to you.

— **N.** ha'mk'ōlisEN, I eat with you.

— **N.** gyinlikyelē, parents with
children.

— **N.** nēmā'la, **A.** wē'wauk'ua'si.
to-morrow, **L.** tlē'nstla, **H.** tla'ns-
tlats.

— day after to-morrow, **H.** tli'nsē-
tlats.

tongue, **L. H. G.** gy'i'lem.

tongs, for pulling out hair, **L.** k'ulai'ō
(= pulling instrument).

— for taking stones out of fire, **L.**
ts'ē'stlala (—tlala, fire); **H.**
k'ōē'sten.

tooth, **L. N. H. G.** gyīgy; **N.** gyī'-
gyatlen, I have —ache; gyī'-
seqstāl, cover of box (= teeth
around (?)).

— **N.** (ōiwē), —nē; k'aqhē, hav-
ing lost a tooth (= notch tooth);
nae'nshē, with decayed teeth;
lōpñēpitō, you have no teeth;
H. —nsiā; tsē'tsēnsia, having
lost a tooth; lē'k'ēnsia, having
lost all teeth; hā'pēnsia, chin
beard (= hair tooth).

top of —, **L. N. H.** —qtlē: **L.** mā'kyaq-
tlaowē, top of tree; k'ā'msiqtlē,
lazy on top; tl'ē'tseqtlē, skin
of crown of head; **H.** gā'luqtlēas,
to sit down on top of —.

— **N.** —ōqtoē, **H. G.** —qtoa; **H.**
goa'qtoa, to sit on —.

— a pile, **N.** ōky'ē; ōkuyalis, on
top of a pile on beach; ō'magya-
lis, highest of all (?); **H.** —koia,
—kyioa; tōkoia', to walk over a

pile of planks; goau'ioa; **G.** goa'gyioa, *to sit on a pile.*
top of basket, box, **N.** —kyaē; wē'-kyaē, *not quite full*; **H.** ky'ā't-gyōt, *to paint inside of box.*
torch, **H.** anō.
to touch, **N.** tlō'pala; mā'kyapala, — *almost*; mākyitlē'sela, *almost touching roof.*
towards, **H.** —alut; tqūā'lut, *to jump* —; gy'ē'qoalut, *to run* —.
town, **N.** gyōk', **H.** gō'kula (= *houses*).
trail (see *Road*), **N.** la'qsō, *to walk on* —; **H.** tō'wi.
trap for fish, **N.** mō'ē; mā'muqsila, *taking care of* —; **G.** ā'mala.
trap for game, **A.** khrāiō, lā'um.
to travel, **N.** ē'iowa; sē'qoa, — *in canoes*; k'unē'sta, — *about* (—ē'sta, *around*); K'unēstā'la-gyilis, *always traveling about.*
tree, **L.** tlā'qilos, **A.** k'oā'as, **H.** lek'oa' (= *fuel*); k'oaiyō'k'ula, lek'oa'gyila, *country full of trees.*
 — **L. N.** —mis; k'oā'tlms, *salmon berry bush*; qā'qumis, *pine*; paā'qmīs, *maple* (= *leaf tree*); iaiqrpā'lamis, *fir*; tl'ā'qomis, *alder* (= *red tree*).
to tremble with hands, dancing, **L.** qō'lēqōla.
tribe, **N. H.** lē'lk'olatlē, **N. G.** gyō'uklōt; **H.** gō'uklōt (= *village community*).
to troll, **H.** k'ē'ma, dō'koa.
to be troubled, **N.** nō'tla, tsīnaqua'la (*in song*).
trousers, **L.** k'qsis.
trout, **L. N.** k'ō'la, quitlā'la, **H.** tk'ā'nē; gōlē'stē, *speckled* —.
trumpet, **N.** ts'ē'kōkyala, **H.** ky'ē'kyala (—kyala, *noise*).
to try, **N.** wā'hsala, *let us try!* hā'maa, *trying to eat*; nā'nak'a,

trying to drink; kwa'na, *to try*; **H.** hā'mats'a, *trying to eat.*
Tsētsā'ēk'a (*winter dance*), **N.** tsētsā'ēk'a (= *the secrets*).
 — *house in which — is held*, tlamē-a'tsē.
 — *host giving* —, yē'winila (= *shaking himself*).
Tsimshian, **N. H.** Guē'tela (= *north people*); **H.** Atlā'itq, *a tribe living west of the Quē'qaes*; **MES-**mā'miint, *tribe of Mettuk'āhtla*; Guē'tela, — *language.*
Tsōnō'k'oa, *a fabulous woman* (ts'ō'na, *thunderbird*; —ō'k'oa, *female* (?)).
turned upside down, **H.** k'pē'tla; k'pē'tla itl, — *in house* (see *To capsized*).
to turn round, **L.** k'ui'sk'emri't (= k'em, *face*); me'ls'it.
tide turns, **H.** ts'ā'ista (—sta, *water*).
twelve, **G.** mātlg'i'ū.
twenty, **G.** mentsq.
twice, **L.** mā'tlp'ana.
twiy, **L.** mā'mē.
twins, **N.** tl'ā'lēatsē (—atsē, *young*).
two, **N.** mātl; Mā'tsemenk'olāwis, *always carrying two round ones in each hand*; **G.** malō'q; mā'sems, — *round ones.*
two hundred, **G.** k'āpōs beguā'num (= *ten men*).
 .
 U.
ugly, **N.** iakyā'ōē (= *bad forehead*).
uncle, **N.** k'ulē' (*addressed*), **H.** qtlēmp.
to uncover face, **L.** lō'semhit (—sem, *face*), **H.** t'ē'lk'emtl (—k'em, *face*).
under, **N.** pen'a; pen'a'tsē, *lower side*; bē'bēnak'aua, *the lowest*; —aboē, *underneath*; aoā'boē, *underneath*; halqabo'ē, *to kill*

- ; **H.** oā'poa; wunk ā'poa, *virgin*, **N.** ky'ēa'la.
bottom, lower side (= *edge underneath*); ēsā'poa, *lower side*;
 mā'taput, *to fly under*; tōā'put, *to walk under cover*.
unexpected, **N.** k'ōc'nit'ā'āstl, *hap-*
pening unexpectedly.
to unloud canoe, **N.** mō'tltōla; **H.**
 wā'mōtlut (—ōtl, *out of*
canoe).
unsteady, **L.** gyē'tēla.
to untie, **N.** k'uī'tla; k'uī'tlaqala,
to untie from trees (—aqa,
down).
upper part of river, **N.** nā'laē; nē'l-
 pē, *house highest up river*; nē'-
 nelgyas, *country highest up*
river; nē'tse, *up river*.
up, **N.** —usta; lagyustā'la, *to ascend*;
 Nēmōkyustālis, *the only one*
coming out of ground; k'ē'hus-
 tāl, *washerwoman* (= *hanging*
up); gyalamustāla, *salmon first*
ascending river; t'Epustāla, *to*
ascend mountain; gyā'qustā, *to*
come up; tsū'husut, *to hold up*;
 wī'kyustoa, *not to be able to hold*
up against; k'asustāla, *to walk*
up; **H. G.** —ōstēoa; lā'kōstēoa,
to walk up; d'ōqsōstēwala, *to*
look up; tqōstē'oa, *to jump up*.
to turn upward, **H.** d'ā'tēk'ēila.
to urinate (male), **H.** k'u'ē'lk'oa.
to urinate (female), **H.** aiā'sa.
urine, **H.** kuiloqpē's.
useless, **N.** gyōkk'ā'laam, —*house*;
H. a'mtla; a'mtlask'am, *a*
strumpet.
urula, **H.** me'smes.
- V.
- rein*, **H.** haia'spēatsēe.
vertebra, **H.** k'ō'tsō (see *Bone*).
village, **N.** gyōq, **H.** gōk', **G.** gyōq;
N. gyōqtēms, **G.** gyō'qtēma,
village site.
- W.
- waistcoat*, k'ē'qsawok'.
to walk, **N.** k'a'sa; k'ā'sēltsue, —
on flat object; k'ā'tsēlanē, —
on log; k'ā'seqala, — *down*;
 k'ā'tsēstāla, — *around*; k'ā'-
 sustāla, — *up*; k'asēnqētāla,
 — *along edge*; k'atsnūtsēntāla,
 — *along long object*; k'ak'asky-
 inā'la, — *and find*; **L.** lā'tlēn
 k'ā'sat, *I* —; k'ak'ā'lagyilis,
walking together; k'autlanēā'la,
to walk meandering; **G.** k'ā'tl-
 tōwa, — *on road*; k'ā'ldzoa, —
on plants; k'atlna, — *over*
log; k'ā'tsistala, — *around*.
 — **G.** lātus, *to walk down river*;
 lā'qa, — *down*; lā'kuīwa, —
up.
 — **N.** tayukuinā'la, — *and find*;
 tāyōk'oa'lagyilis, *walking to-*
gether; **H.** tōnō'olsa, — *along*;
 tōā'put, — *underneath*; **A.** tō'-
 quit (**N.** = *war dance*).
 — **G.** sī'q'uit, — *up river*.
 — *on trail*, **N.** ts'ē'k'oa
 — **N.** hauqsā'yō, hauqsā'lo, — *on*
trail; hōqsta'la, — *into water*
 (—sta, *water*).
 — **H.** uaqoaqtoa, *to smoke walk-*
ing; **G.** ha'mstoa, *to eat walk-*
ing; ha'nqtoa, *to sing walking*;
 k'ā'k'paqtoa, *to smoke walking*.
 — *softly*, **N.** se'lalala.
wall, **L.** tsā'k'am; **N.** gyōk'opa'sila,
 — *at point*; **H.** gāuwim.
wanting to, **L. N.** —ēqst; mē'q'ēqs-
 tēn, *I want to sleep*.

- not obtaining what one wants, **N.** wī'ñtl.
- war, **N.** hō'utlō, to go to — ; **H.** ts'ē'kyatla.
- dance, **N.** tō'q'uit (see *To walk*).
- warm, **N.** ts'E'lqua ; ts'E'lquat, place where it is warm ; **H.** kō'qoa, **G.** ky'u'qula.
- to warm one's back, **L.** penē'kyalitl (—ēkyā, back).
- warrior, **N.** wināe'noq ; ā'listalits, great — (perhaps victorious).
- to wash, **L.** tētēk'EMU'it, — face (—k'EM, face); lā'asta, — body (= to go into water : la, to go ; —sta, water) ; tsE'ntsenk'oa, — hands ; **H.** ts'ō'tsoqma, qau'semāt, — face (—SEM, face) ; ts'ō'qoēta, — body ; muqsta', — body (—sta, water) ; ts'ō'k'oa, — hands ; dēi'sēta, — with cedar branches ; ky'i'lpa, — clothing.
- washbowl, **H.** ts'ē'koisk'EM (—k'EM, round).
- watchman, **L.** k'ā'k ala (see *To hear*).
- water, **L. N.** wa'p, **H.** waa'm.
- **N. H. G.** —sta ; **N.** k'ola'sta, water of life ; tsuqsta, to jump into — ; koā'asta, cup ; **H.** tlqsta'ūt, to push canoe into — ; tqsta, to jump into — ; nak'a'msta, cup (= drink water) ; **G.** gyūqstā'is, house in —.
- is, in sea, **N.** k'atsi's, bottom of sea ; nā'nīs, bear in sea ; **H.** k'alīā'ois, anchorstone.
- on water (see *Surface*).
- wave, **L.** k'elē'e ; aqumā'lē, breaking wave ; **H.** gane'mala.
- we inclusive, **L. N.** nō'guaments, **H.** nō'guants, **G.** nōguā'nīs.
- we exclusive, **N. G.** nō'guanūq, **H.** nōguā'ntk'.
- weak, **G.** wē'tlimas (= not strong).
- weasel (*Putorious*), **N.** gyēgyi'lEM (= climber).
- weather, **N.** nā'la ; nēnā'lanuk, having — (i. e., being able to change —).
- to weave basket, **L.** yi'p'a.
- cedar bark mat, **TL.** ky'ē'ta ; ky'ē'tamitl, weaving frame ; **H.** tlē'huila.
- rush mat, **L.** ō'ta.
- wedge, **N.** tle'mkyaiō, **A.** tlā'nut.
- weir for fishing, **N.** mō'a, **A.** kō'lem, **G.** mā'mēas.
- west, **H.** qā'īs ; qā'ēqāē, western people.
- whale, **N. H. G.** k'o-i'm ; **N.** k'oē'gyilak', made a — ; k'oā'fastems, place of whales.
- **TL.** t'ōto'sk'amis (a. p. (?) perhaps = star-fame in sea).
- whetstone, **L.** t'ē'kyaiō.
- whirlpool, **L.** k'ō't'is (—is, in sea).
- whirlwind, **L.** halō'pēk'a.
- whiskers, **N.** hāpqstē'e (= mouth hair).
- to whistle, **N.** hō'uqoa.
- whistle, **N.** metsē's, — of hū'mats'a ; ts'ē'kōkyala, trumpet ; **A.** k'oa'k'ōmōlaku'la, — of mō'itla ; ky'ē'kyala, trumpet ; k'ōs, — of tloola'qa ; tē'qatsk, — of tsā'ēk a ; **H.** nuē'k'oa, — small.
- white, **L.** mela', **H.** mō'k'oa, **G.** mō'qstō.
- white blanket, **H.** kye'lqsem.
- who is that? **A.** ak'oīq'au.
- wide, **N.** lē'qō ; lē'qōis, wide beach.
- widow or widower, mourning, **N.** ā'amsila, **G.** g'ōā'itlōwa (= sitting in house).
- widow, **N.** beky'ā'sit (= without man).
- widower, **N.** k'eky'ā'sit (= without woman).
- wife, **N. G.** gane'm ; **N.** gane'mtl, future — ; **H.** g'ane'm.

wild, *hā'mats'a* growing —, **N.** quā'sa.
wind, **L.** iā'la; iā'oapsēm, *sail*;
 iā'u'pek', *mast*; **H. G.** iā'la;
H. iā'lis, *place where always*
wind; iā'u'aspek', *mast*; iā'u-
uastēm, sail; iā'u'atsk, *hoisted*
sail; **G.** iā'u'atsēm, *sail*; iū'p'iq,
mast.

— *north wind*, **N.** t-ā'k'oa, **H.**
 tsāk'oa'la.

windpipe, **H.** pētseqā'ō (—qāō, *neck*).
wing, **H.** mā'tlmatēm (see *To fly*).

— *first feathers of* —, **L.** p'ē'tlēm.

— *hind feathers of* —, **L.** ts'ē'l-
 khim.

winter, **L. N.** tsawā'nq, **H.** tsawu'nq,
G. tsōnq (—anq, *time of*).

wise, **N.** nō'k'at; nā'k'atsē, *the*
great wise one; nō'k'amō, *born*
wise; nanō'ak'aua, *the wisest*
one; **H.** nō'ak'aua, *the wisest one*.

to wish, **N.** ā'itla.

wolf, **L.** ā'tlanēm (see *Inland*); **N.**
Nuqnemis name, Nūn; Nūnkyē'-
 qūō, *chief of*—; Mamalēlēk'ala,
 ōlē'kyin, **H.** k'use'ls, **G.** asila',
 tl'esyegumi'h.

wolverine, **N.** wā'gigya, nā't'bēē.

woman, **L.** tsetā'q.

— **L. N.** k'aky—; **N. G.** k-ā'kyala,
woman speaks (= *woman's*
noise); **N.** k-ā'qk'ēkyā'la, — *is*
always talking; **H.** k'ky—;
 k'kyala, *woman speaks*; k'ky-
 apē's, *female talker*.

— **N.** —k'as; —k'a: nēmē'mak'as,
sister; k'ōk'otsaqsemā'lak'a,
Koskimo woman; hā'at'ilalak'as,
mending woman (= *female shu-*
man): ts'ō'tlemak'as, *grand-*
daughter; ā'tak'a, *pet daughter*;
 nē'nenk'as, *bear woman*; **H.**
 —k s; menū'yak's, *sister*; tluse-
 la'k'sa, *shrew*; ts'ō'qtlemak's,
granddaughter; g'anioa'qtlēk's,
second daughter; hau'ldsēk's,
only daughter.

woman, **N. H.** —aqsem; **N.** Nim-
 k'ēa'qsem, *Nimkish woman*;
 Guā'gulaqsem, *Kiwakiutl wo-*
man; **H.** Awī'wiky'a'qsem,
Awiky'ō'noq woman; Bī'bilqu-
 la'qsem, *Bilgula woman*; k'ōē'-
 k'ōēntēnoqa'qsem, *K'ōchtēnoq*
woman; Tlatlasik'oa'qsem, *Tla-*
tlasik oala woman; Hēiltsōk'ō-
 a'qsem, *Hēiltsuk' woman*,

— **N. H.** —ūk'oa, —ōk'oa, —in
names; **N.** A'nk'oalayū'k'oa,
making it cloudy; Lālak'āiyū'-
 k'oa, *made to go ahead of all*;
 Tsōnō'k'oa, *thunderbird wo-*
man (?) **H.** Tlālēt'ilalayō'k'oa.

womb, **H.** mā'ēōtlatsē.

wonderful! **TI. N.** sā'kyas, au'ila
 (= *real*).

wood on beach, **L.** k'ē'qatl.

— *dried*, **A.** kyā'p'as.

— *damp*, **A.** ts'ē'mos.

woodpecker, red-winged, **L.** sā'k'oa,
TI. tlā'tlanitl, **L.** tlā'tlanē'k',
H. tlā'tlapēkn.

wool of mountain goat, **L.** p'ā'lēm;
 pelpe'la'sk'ēm, *blanket of* —.

wool and fine hair, **H.** kyā'tltema.

word, **N.** wā'tldēm.

world, **N.** wī'nakuis.

Y.

to yarn, **L.** hā'nila.

yellow, **H.** tē'qa.

yes, **H.** la'a, **G.** kyaā'.

yesterday, **L.** tlā'nsutla, **H.** tla'ntsē.

— *day before yesterday*, **H.** tlā'-
 ntsēēda.

yeu tree, **TI. H.** tlē'mk'a.

you, **H.** k'āēk'soā'ea, **G.** yii'qsō.

young man, **L. N.** lā'bakum, **N.**
 hē'itla.

young of —, **N. H.** —atsē; **N.** mā'-
 matlatsē, *half breed* (= *young*
of European); k'ō'tsatsē,
 — *crab*; **H.** tsāca'tsē, — *beaver*.

The Life History of Certain Moths of the Family Cochliopodidæ, with Notes on their Spines and Tubercles.

By A. S. Packard, Providence, R. I.

(Read before the American Philosophical Society, February 3, 1893.)

I am under special obligations to Miss Emily L. Morton for the eggs of several species of this family, which gave me the opportunity of rearing them and thus of observing the freshly hatched larvæ of species of three genera of this most interesting group, none having heretofore been described, unless we except a very brief notice in Buckler's *Larvæ of the British Butterflies and Moths* (iii, 76) of the freshly hatched larva of *Heterogenea asella*, as follows: "As well as my strongest lens would show them to me, these very small specks of creatures were of an ovate, roundish figure, dark brown above and pale greenish beneath—in short, miniature representations, apparently, in all respects of the mature larva."

I was very eager to learn whether the freshly hatched larva of any of this group was born in the form of the fully grown larva, and entirely without abdominal legs, or whether its body might not be more generalized in shape and structure and with the vestiges at least of such legs. The result appears to be that, the young larvæ are, so far as known, without traces of abdominal legs, and that while those of the more specialized though primitive genera, as *Adoneta* and *Empretia*, are born with the tubercles already nearly as much specialized as in the full-grown larva, in the more modified genus *Lithacodes* (*L. fasciola*), the body is much more cylindrical and simpler, and thus more modified than in the foregoing genera, being without tubercles, but with forked glandular setæ.

Another result of great interest is that the shape of the young larva of *Adoneta* and also of *Empretia*, with their large tubercles bearing three radiating setæ or bristles, is such as to remind us of the larvæ of the Saturniidae, and to suggest one of two alternatives, viz., (1) either the Cochliopodidæ have originated from the Saturniidae or forms allied to them; or (2) both the Saturniidae and Cochliopodidæ have descended from a common stem-form, and this perhaps some Notodontian.

At all events the systematic position (and in this connection I may say that the pupal and imaginal characters bear me out) of the group represented by *Limacodes* and its allies is very near the Saturniidae, and not far from the Notodontians. It would seem as if the oldest, most generalized, or less modified forms, viz., the original ancestors, were the tuberculated larvæ of *Euclea*, *Adoneta* and *Empretia*, as they are more like the larvæ of other Bombyces, particularly the Saturniidae and Notodontians. On the other hand the nearly smooth slug-worms, without hairs or tubercles when fully grown (such as *Limacodes* and *Heterogenea*), seem to be the most aberrant and modified, viz., have become the most adapted to the peculiar mode of larval life emphasized by the term "slug-worm;" these

being caterpillars which have lost by disuse their abdominal legs, the thoracic ones being greatly reduced in size, while by their sluggish disposition, by their slug-like, slow gliding mode of progression, and by the peculiar coloration of such forms as the larval *Heterogenea*, which mimics the red, swollen spots on the leaves of various trees, particularly the oak, chestnut, wild cherry etc., we have, as the result of gradual modification brought about by adaptation, perhaps the most strange and bizarre type of Lepidopterous larva in existence.

Thus, as a result of adaptation, probably brought about by a series of causes unlike those affecting any other caterpillars, we have larvæ which, as in that of *L. fasciola* and also the larvæ of *Packardia*, are entirely green, oval in form, and which we have noticed might easily be mistaken for a fold or bend in a leaf. These smooth bodied, unarmed slug-worms are protected (1) by their oval shape, the expanded edges of the body appearing to merge into the surface of the leaf; (2) by their sluggish almost imperceptible gliding motions; (3) by their pale pea-green ground color, with faint yellowish or reddish shadings on the more exposed ridges and projections of the body. These and other wholly green ones may have been eliminated during the struggle for existence from the earlier, tuberculated genera by their resemblance to green galls or swellings on the surfaces of leaves. That the larvæ of *Heterogenea*, such as *H. flexuosa* and *H. testacea*, are wonderfully similar to the red dipterous or aphidid galls on oak and other leaves was first suggested to us by the late Mr. S. Lowell Elliott,* and since then we have frequently verified his observations, and been struck with the wonderful resemblance between these larvæ and the small reddish and greenish galls which appear late in summer on the leaves at the time when the larvæ themselves become fully grown. These forms being thus protected from observation and harm, do not need the armature of the other group, the tubercles and spines have disappeared through simple disuse; while being without poison-bearing spines, they have also lost by disuse the bright colors and conspicuous spots of the armed genera. On the other hand, the larvæ of *Adoneta*, *Empretia*, *Euclea* and allied forms, with their remarkably bright colors and markings, and poison-bearing tubercles, feed conspicuously, the warning colors and showy ornamentation repelling the attacks of birds. We are inclined to the belief that the armed slug-worms were the earlier, from the probability that in the Coleoptera the earliest and most generalized groups were the Staphylinidæ, and the carnivorous Carabidæ, and allies, while the later, most extremely modified forms were the Weevils and Scolytidæ, in which the larvæ are footless. In the Diptera also it is not improbable that those families with the most perfectly developed larvæ, such as the Culicidæ

* Compare the remarks of Mr. Poulton on the meaning of the peculiar method of progression in the larvæ of *Cochliopodidæ* in *Trans. Ent. Soc.* of London, 1888, 591, wherein he states that Mr. Tate could not remember any object which the larvæ of *H. oslla* resembled. Mr. Poulton remarks that they "may suggest the appearance of some kind of gall on the surface of the leaf."

and Tipulidæ, were the earliest and most generalized types, while the Muscidæ, with their apodous maggots present the extreme of modification though not of specialization, and so with other apodous insects and apodous Arthropoda in general.

To return to the Cochliopodidæ: the great difference between the tuberculated and spinose and the smooth, unarmed genera show that the forms were more or less plastic, and though all of them are born without abdominal legs, yet after atrophy had taken place, the larvæ of different genera became exposed to quite different surroundings and stimuli, and responded to such varied changes with the result seen in the numerous genera characterizing the eastern regions of North and South America, as well as Southeastern Asia; Europe only possessing two species, and none being yet known from the Pacific slope of North and South America.

It will, of course, be a matter of great interest to examine the embryos of this family in order to determine how late in embryonic life the abdominal legs disappear, for, undoubtedly, as in the embryos of such Lepidopterous larvæ as have been examined by embryologists, each segment bears a pair of temporary embryonic legs. Probably the legs are represented by the transversely oval ventral areas or muscular folds on each segment of the abdominal region in the slug-worms.

As a result of studies with larvæ and moths I may add that the genus *Heterogenea* is more largely represented in the United States than formerly supposed, and the genera *Kronea* and *Tortricidia* are with little doubt synonyms of *Heterogenea*, the characters which I originally employed not being of generic value.

THE LIFE HISTORY OF *EMPRETIA STIMULEA* CLEMENS.

I am indebted to Miss Emily L. Morton, of East Windsor, N. Y., for the eggs of this interesting form. The larvæ hatched July 9 to 12 at Brunswick, Me., from the eggs sent a few days previous.

Egg.—As usual in the family, an irregular, oval, flattened, scale-like body, with a very thin edge; under a half-inch objective the shell is seen to be thin, transparent, and without any markings. They are laid in an irregular mass, partly overlapping each other. Length, $1\frac{1}{2}$ to 2 mm.; breadth, 1 mm.

Freshly Hatched Larva.—Length, 1.2 mm. The body is broad and high, about three times as long as high, but much more cylindrical than in the full-grown larva. The head is pale and the body is pale straw-yellow. The eyes are black and distinct. The prothoracic segment is large, somewhat hood-like, not bearing any visible tubercles, but with two obsolete warts, giving rise each to three hairs. The other segments are in this stage distinctly marked, especially dorsally and ventrally. On each of the second and third thoracic, and the first abdominal segments is a pair of high conical tubercles, which are moderately thick at base, and nearly as long as one-half the thickness of the body, each giving rise to but three

setæ, which on the average are about three-fourths as long as the tubercles; the first (mesothoracic) pair are as large as the second and third, all being alike in shape, length and size (Fig. 1).

Succeeding the three pairs of large high tubercles are five pairs (on segments 2 to 6) of tubercles which greatly contrast in size with those at each end of the body, being very much smaller, only about one-third as high as the others, or about one-half as high as the others are thick in their middle. On the end of the body are three pairs of large tubercles, the first pair of these (on abdominal segment 7) being larger and thicker than those on the thoracic and first abdominal segments; those of the pair on the eighth segment are about as large as the pair in front, but those on the last pair (on the ninth segment) are about one-half as large and long as those on the eighth segment. They all bear only three setæ each.

The setæ or hairs appear under a half-inch objective to only taper like a simple seta, the tip, however, not being acute, neither very blunt; but under a higher power ($\frac{1}{2}$ obj. A. eyepiece), the points are seen to be divided or forked, but with only two divisions. Fig. 2 represents a tubercle highly magnified, showing the finely forked glandular setæ, each of which is moved by a retractor muscle (*m*).

Larva. Stage II.—Length, 5 mm. The three anterior pairs of tubercles are paler, the largest (hinder) thoracic pair much darker reddish purple. Between the first and second dorsal pair of tubercles are two parallel dorsal rows of three pale dots, forming two short parallel broken lines. A yellow spot between the two larger tubercles, and in front is a fine transverse line connecting two yellow dots, and a similar smaller mark behind the yellow spot. Three similar marks, *i. e.*, a yellow median spot and two transverse lines at the base between the abdominal tubercles. The brown-and-white edged lines nearly enclose each set of tubercles as before. The body is green and straw or lemon color above, and greenish amber low down on the sides.*

Stage III (?).—(July 23.) Length, 6 mm. The ten anterior fleshy appendages are all pale lilac; those in front the paler; the second dorsal pair about one-third larger than the first pair, and the third pair about one-third larger than the second, and nearer together at their base; the latter are deeper purple, and are dark at the end. The large pair near the end are also purple, and only slightly larger than the second anterior

*Miss Multifeldt thus describes the young, probably in Stage II, as she observed them at St. Louis: "Late in August of the present year I found quite a colony, probably ten or twelve, on a single leaf of the above-mentioned tree. They had but recently hatched, but tiny as they were—not more than an eighth of an inch in length—they had all the tubercles and other characteristics of the mature larva, except that the saddle-cloth-like spot was deep yellow instead of green and the central dorsal spot pinkish gray. They had perforated the leaf with small irregular holes. Not thinking that they would readily loosen their hold on the leaf, I carried it carelessly in my hand, and when I reached the house was much disappointed to find that but two larvæ remained on it. As these thrived and perfected their development to the point of enclosing themselves in cocoons, it is evident that maple may be included in the list of their food-plants" (*Bull. Dir. Ent.*, 13, 65).

pair. The small pair of dorsal ones near the end are greenish yellowish. The two lateral ones in front on each side are about three times as large as the eight on each side behind them, and they are purplish, while those (the eight) behind are pale greenish.

On the back, behind the first pair of appendages, are two parallel purplish longitudinal patches, with the pale whitish median line between them, and behind them are two dark patches, also separated by the median line. Between the second and third pair of appendages is a transverse dark brown stripe, which passes around behind the appendages but does not meet behind, and behind it is a roundish yellowish median patch; behind this patch, between the bases of the two appendages, is a short transverse white line. The tip of the body behind is lemon-yellow, and on the second, third and fourth segments behind the third pair of appendages is the saddle-like median spot. It has a median oblong lilac-brown patch, bearing two transverse broken white short stripes edged with brown. On each side of this patch is a white border with three scallops externally, and edged with black, the black line forming three scallops. The two large purple posterior appendages are partly surrounded at base by a brown curved line, the two not meeting in front or behind, and between the bases of the long conical fleshy tubercles are two linear dark stripes. The rest of the body is pale greenish, with a slight yellowish tint. The appendages have each slender purplish spines of quite even length. It is bright colored and showy, and must depend on its spines for immunity from attack.

It feeds in this stage on the upper surface of cherry leaves, eating off the surface, leaving large dark patches. Crushed one of the small ones, and found the hairs painful and annoying to my hand.

Stage III or IV (?).—Length, 7-8 mm. The thoracic segments—*i. e.*, all the region bearing the anterior tubercles or papulae—is now dark reddish brown; the third, or hinder thoracic tubercles, dark reddish brown, and the yellowish dots and lines are obsolete, only the bright yellow spot behind the third pair of thoracic tubercles being left. The two anterior pairs of tubercles are much paler than the third pair and the pair on the eighth abdominal segment. The last pair on the end of the body are pale amber. The lateral papulae or tubercles are still green. The yellow dorsal region between the thoracic and abdominal papulae is now yellow, edged with white on the side low down, and in front and behind are white borders edged part of the way with dark reddish brown. In front of and behind the "saddle" are two twin dark dots. The saddle is plain brown, oval, cylindrical, bordered with white, which is edged within with rosy, and, on the outer edge, with dark brown, this border being interrupted in front and behind, opposite the twin dark dots. All around, and at the base of the large tubercles on the eighth abdominal segment, the back is dark reddish brown with a median yellow spot, and behind on the next segment are two large oblique oval white spots, meeting on the middle of the body, and faintly tinged with lemon-yellow.

Full-fed Larva.—Length, 20 mm.; breadth, 7 mm. The body is very thick and stout, nearly one-half as long as broad, the dorsal surface regularly convex, being well rounded above, a little wider in front than behind. The prothoracic segment, with no tubercles, forming a hood for the head, which is dull amber colored with darker spots. The second thoracic segment with four spinulose fleshy conical tubercles, the dorsal ones slightly larger than the lateral ones. Similar ones on the third thoracic segment, but they are a little larger. On the first and eighth abdominal segments are two very large diverging horn-like processes, and armed with coarse spinules, which like those elsewhere are simple, ending in a slender, stiff corneous black point. On the last segment is a pair of small tubercles and a terminal pair of rust-brown flattened branches of singular spinules. The body is rust-brown, with a livid hue, and the skin is granulated. Abdominal segments 2-7 are pea-green, bordered below with a white lateral line, and enclosing a large dorsal round brown spot bordered with whitish. Between the base of the horns is a small pale spot, and behind are two nearly adjoining yellowish-white patches.

The shape of the stout spines on the tubercles of the full-grown larva is represented by Fig. 3, *a*, which is, however, one of the smaller spines. A singular spine is represented at Fig. 3, *b*; it is clavate, and arises from a papilla situated on the middle of the tubercle near the edge; such clavate setae as these are very rare, the only other one observed was situated on the middle of another tubercle below the group of papillae, which extends to the end of the tubercle. A very remarkable spine, and one which we believe is largely concerned in producing the poisonous and irritating effects resulting from contact with the caterpillar of this species, is one situated in scattered groups near the end of the tubercles. A group of three is represented at *c*. They are not firmly embedded in the cuticle, but on the contrary appear to become very easily loosened and detached, and they probably, when brought into contact with the skin of any aggressor, burrow underneath, and are probably in part the cause of the continual itching and annoyance occasioned by this creature. It will be seen by reference to Fig. 3, *e'*, that the body of the spine is spherical with one large elongated conical spine arising from it, the spherical base being beset with a number of minute, somewhat obtuse spinules. This spine reminds one of an old-fashioned caltrop, and a group of them constitutes a formidable armature. The cuticle at the end of the tubercles is granulated, each fine projection being the end of a vase-shaped papilla, all being closely crowded together, as at *c*. The skin of the body between the tubercles is seen to be finely shagreened, an appearance due to the presence of fine clear teeth more or less curved and bent, which arise from a very finely granulated surface, as at *d*. It will thus be seen to what an unusual extent the differentiation of the spines and of the armature of the cuticle itself is carried in this highly specialized form.

Miss Murtfeldt has called my attention to the variation in the larva in the length of the tubercles, in the intensity of coloring, and the presence or absence of the cream-colored spots.

RECAPITULATION OF THE MORE SALIENT ONTOGENETIC FEATURES.

A. *Congenital Adaptational Features.*

1. The tubercles on the second and third thoracic and the first, seventh and eighth abdominal segments three times the size of those on abdominal segments 2-6; these tubercles being already differentiated at birth and more markedly so than in *Adoneta*.
2. Head not capable of being withdrawn into and concealed by the prothoracic segment.
3. The tubercles each bear only three two-forked glandular setæ.
4. The body is more cylindrical than in the later stages, and colorless.

B. *Evolution of Adaptational Features.*

1. In Stage II the form and general colors of the full-fed larva are assumed.
2. The tubercles are now armed with numerous poisonous spinules.

Note.—From what we now know of the congenital, as compared with the later acquired adaptational characters of *Cochliopods*, it is evident that the latter are acquired at an earlier stage than in most other caterpillars.

LARVA OF *EUCLEA QUERCETI* (H. S.) (MONITOR PACK.).

The following description is based on over a dozen individuals, found from August 25 to September 8 at Brunswick, Me., on the red or swamp maple and the beech, most abundantly, however, on the former, and always on the under side of the leaves.

Last Stage.—Length, 18 mm.; breadth, 5-6 mm.

The outline of the body seen from above is regularly elliptical, each end being alike. Body with a broad dorsal, flat, plateau-like surface, not so wide as the body, extending from one end to the other, and bearing a row of high conical papilliform tubercles of unequal size. From this plateau-like surface the sides of the body fall away nearly vertically down to a slight ridge bearing long slender papulæ, and situated above the edge of the creeping disk. The body is in general pea-green of two shades, a lighter and darker, with a yellowish hue, assimilating it to the color of the under side of the leaves of its food-plant.

Along the body are two dorsal rows, wide apart, of high, elongated, densely spinose conical tubercles, the spinules black on the distal half. Those of the first pair, situated on the second thoracic segment, are green; those of the second and third pair yellowish; those of the third pair are larger than the second, and the second than the first. All these tubercles are usually reddish on the distal half. On the next five segments is a pair of small rounded tubercles; the first pair, situated on the second abdominal segment, the smallest, and the third pair the largest. The ridge bearing these tubercles is orange, edged with yellow. Between the second and third pair of large anterior tubercles is a rounded madder-brown

spot, and a much larger second one between the first and second pair of small tubercles, which is a deep rust-red or brown-madder squarish or oblong patch; a similar one lies between the fourth and fifth tubercles, and a fourth smaller, more rounded one between the first and second pairs of the large terminal tubercles. At the end of the body are three pairs of high conical tubercles like those in front. The two anterior pairs are the largest, and those of the posterior pair project out horizontally backwards and are green, the others being yellowish. In the green median dorsal space is a pale median dorsal line, edged distinctly with black, and the sides of the area are edged with black, and dilate near the base of the tubercles, forming black blotches.

The outer side of the subdorsal ridge is edged with black in the same way, and this system of black marks connects with a lateral series of polygonal nearly circular black rings on the vertical sides of the body, and each enclosing two pale, depressed, oval, green areas. There is a lateral series of nine green, long, slender, pointed, spinulate tubercles. Nearly each tubercle on the upper side bears a large pale brown patch like a mass of sand (under a high-power Tolles' triplet I cannot discover the nature of this sand-like mass, which is wanting on the first two and last one). At the end of the body are four conical, high, deep black pencils of fine hairs; one between the last and penultimate subdorsal tubercle and another in front between the penultimate subdorsal and last lateral tubercle. On the first thoracic segment are a few fine hairs; it is green and not spotted. The head is green, with the mouth-parts dark. Fig. 4 represents a dorsal tubercle with its spines; it is perhaps from too old a specimen to show the unicellular poison glands at the base of the spines; *s.*, a single forked minute spinule; *ct.*, the cuticle at the base of the tubercle containing clear roundish spaces with a raised edge. There seem to be no caltrops or minute spines in the cuticle of this genus.

Two specimens living on the oak were received from New York through Mr. Simpson. One of them is colored as usual, but the subdorsal madder-brown or reddish squarish spots between the papule are dull and rather faint. The other, larger, is quite different in color from normal individuals. The body and dorsal papule instead of green are dull orange-reddish, while the reddish patches between the subdorsal papule are faint and smaller than usual. The network of what are usually black lines on the sides is rather reddish. The polygonal lateral areas include an upper often dumbbell-shaped pale spot, and a lower double pale spot, the oblique oval spot being supplemented by a pale dot just below and in front. The posterior black conical tuft of hairs is much larger than the lateral ones in front.

It began to spin a thin cocoon September 14.

Two full-grown larvae, apparently of this species, were found August 1, on the back of a pear tree and received from J. H. Pearson, of Portsmouth, N. H. I will copy my description: Body oblong, flattened beneath, convex above, with a slight subdorsal ridge on each side of the

back, giving a slightly quadrilateral outline to the animal in section. It is pale ultramarine green, the fleshy conical spines or papulae being deeper green. Of these papulae there are two subdorsal rows, ten in a row, and otherwise as already described. The spinules of these papulae are white at the base, with the distal end black. There is a row of lateral spines similarly spinulated and of uniform size. The four pairs of square spots are blackish, those of the anterior pair (on second thoracic segment) being rounded. They are more or less connected with dorsal irregular lines and dots. On the side of each segment is a blackish ring, lined within more or less distinctly with white, and enclosing a roundish hexagonal green spot.

Remarks.—The larvae of the genus *Euclea* are wonderfully differentiated and specialized as to their papillae and surface markings, as well as colors. The object of this or rather the process by which these structures and markings have gradually appeared, can, so far as we can now see, only be explained by supposing that they are warning structures and colors, the gay colors enabling the insect to be easily seen and the forbidding spines preventing their being swallowed by birds after once being detected. On the other hand, the more plain, unarmed larvae of *Heterogenea* are instances of protective resemblance, as their lives are saved by their exceedingly sluggish movements and their green colors, assimilated to the hues of the under side of the leaves, in which they rest, for the most part nearly immovable. Yet why should *Euclea* feed like *Heterogenea* and allies on the under side of the leaf, and not on the upper, where it would be readily seen?

PARASA CHLORIS H. SCH. (P. FRATERNA GROTE).

The larva, like those of many other Cochliopods, lives on the under side of the leaf of its food-plants. It often, however, begins at the end of a leaf and eats down to the base; it remains on the under side, but the hood bends over so as to be seen from above, but the color, exactly like that of a brown sere part of the leaf, protects it. Several specimens were kindly sent me by Miss Morton, September 4.

Full-grown Larva.—Length, 15 mm. The body is oblong, square; when seen in section it is somewhat trapezoidal, the dorsal surface being flattened, though still somewhat convex, and one-half to two-thirds as wide as the creeping disk or under side of the body. Posteriorly the body ends in a long, slender, fleshy projection or "tail," which is somewhat spinose and slightly forked at the end. Along each side of the dorsal area is a row of short, thick, retractile tubercles which bear peculiar stout spines, which are whitish, tipped with brown at the ends. Fig. 5, *sp.* represents a part of one of these tufts of sharp spines, which are white, becoming dark towards the ends; *ct.*, the spiny cuticle of the body, the spinules being modified cuticular cells; *ct'*, the same seen from above. A few caltrops were to be seen. The third pair from the head is situated nearly on

the second abdominal segment, and is twice as large as the others; those on the eighth abdominal segment are much larger than the other abdominal tubercles (which are minute), and the spines on this pair are whiter than those on the other tubercles. A brown line washed externally with paler bounds the sides of the back. A lateral row of small tubercles bearing spines is situated around the edge, the middle of each tubercle being raised, convex. The spiracles are minute, white, somewhat raised, and situated in a darker round area. Low down between the two rows of tubercles is a row of smooth, kidney-shaped depressed spots. The head is chestnut, the labrum paler. The under side or creeping disk is pale flesh color edged above with a reddish stripe, becoming reddish brown above. The body above is of a rich velvety dark flesh-red brown. Some individuals are much darker than others. The under side of the "tail" is flesh colored, reddish above, and on top of a rich brown.

In this species the spiracles are plainly seen to be arranged, as in *Lima-codes scapha*, on the side of the body rather low down, but above the edge of the creeping disk.

In *P. chloris* (*fraterna* Grote) the tail-like end of the body is longer and better developed, and more movable and nutant than in the larva of Packardia. It is slowly raised and lowered while the animal is creeping, with the result that it must be deterrent to ichneumon and other insect enemies. The "tail" is quite hirsute, and is flesh-colored below and at the end, but on the upper side is brown like the body. It varies in length. The "hood" or prothoracic segment is in this species larger and freer from the second thoracic segment than usual.

On one of the larvæ was observed an oval cylindrical ichneumon egg.

LIFE HISTORY OF ADONETA SPINULOIDES HERRICH-SCHAEFFER.

Batches of the eggs of this Cochliopod were also very kindly sent me by Miss Emily L. Morton, from New Windsor; they hatched July 18 or 19. The eggs are so flat, scale like and transparent, that they must be very difficult to detect on the leaf of the food plant. Thus the eggs must be to an unusual extent free from attack of other insects or the gaze of birds, etc.

In Stage II, when feeding, the upper (never the lower) surface, says Mr. Bridgham, is eaten, and all the contents, leaving only the lower skin of the leaf, thus forming little pits on the surface.

Egg.—Very flat, rounded, oval, with very thin edges; varying much in size, some being twice as large as others, varying from 0.7 to 1.4 mm. in length, and nearly as broad as long. The cast shell is thin, membrane-like, not preserving its shape after the exit of the larva, and not showing any markings. Though the eggs themselves vary so much, yet the larvæ within are of nearly the same size. This variation in size is very unusual in insects and may be correlated with some interesting peculiarities of the oviduct.

The Freshly Hatched Larvæ.—Length, 0.8 to 1.2 mm. The body is oval, cylindrical, with both ends nearly alike. The dorsal tubercles are large, prominent, conical; those on the second and third thoracic and first abdominal segments are large, conical, and twice the size of those on the second and third abdominal segments, while those (in one of my specimens) on the fourth segment are as large as those on the first or seventh segment, but in another no larger than those on segments 2, 3, 5 and 6; those on segments 5 and 6 are of the same size as those on segments 2 and 3; those on segment 7 are as large as those on segment 1; those on segment 8 a little smaller than those on segment 7; those on segment 9 of the same size as those in the middle of the body. From each of these tubercles arise three glandular hairs or setæ, which are on the average about a third longer than the tubercles themselves; they are rather stout, tapering slowly from the base to the tip, slightly curved, and divided at the end (as seen under a $\frac{1}{2}$ objective B eyepiece) into three short minute forks.

There is a lateral row of tubercles, one to each segment, beginning with the second thoracic, which are smaller or about half as large as the smallest dorsal ones, and each bearing three setæ. The segments are quite well distinguished. The head is white, about one-half or two-thirds as wide as the body; the latter is at first pearly white, and later with a purplish shade on the back; the skin is very finely granulated, and the spines are blackish towards the tips.

Fig. 6. A camera sketch, from an alcoholic specimen, of the freshly hatched larva; both rows of dorsal tubercles are represented (author del.). Fig. 7. A restoration of the same by Mr. Bridgham, corrected by the author; *f*, front view. Fig. 8, *a*. Third thoracic dorsal tubercle (or first abdominal), bearing three spinules at the end, each terminating in three short, minute, obtuse forks; *a'*, ends of four spinules; from each fork or branch a stria passes down to the base of the spinule.

The following description of Stage II has been drawn up from a specimen stated by Mr. Bridgham (to whom I sent the eggs and freshly hatched young) to have molted once, and from which he made his Fig. 215. The drawing was made July 20, the specimen feeding on the scrub oak.

Stage II.—Length, 2.8; width, 1.4 mm. The larva is now at least three times as large as before molting, and it would be difficult (as I have not myself seen the larva alive in this stage) to believe that it could be in Stage II, unless Mr. Bridgham had noted the fact on his sketch that it was drawn “after the first molt.” The larva has now assumed nearly the shape and nearly the colors of the fully-grown larva, the tubercles even being a little larger in proportion, and with the spines as numerous and as large as in the last stage. The body is broad and flat, and the head is entirely concealed by the prothoracic hood. The skin is finely granulated. The tubercles are now completely differentiated, and are indeed a little larger in proportion to the body than in the full-grown larva.

Fig. 9 represents a small anterior lateral tubercle after the first molt; the unicellular poison cells not distinctly seen; *a*, a larger lateral tubercle.

Fig. 10, tubercles of last stage; *a*, tubercle with venomous spinules; *b*, space at the base of a tubercle densely covered with caltrop-like spinules; these caltrops are very easily loosened, and can readily work under the skin; *c*, end of a tubercle; *c'*, part of the base of a tubercle, with the granulated cuticle near the base; *d*, two caltrops enlarged; *e*, two venomous spines, with the unicellular gland in the expanded base of the spine; *e'*, a spine of different shape on the same tubercle (author del.).

The second and third thoracic dorsal tubercles are a little slenderer and smaller than the pair on the first abdominal segment. The pair on the fourth abdominal segment are nearly three times larger than those on abdominal segments 2, 3, 5 and 6; those on segments 7 and 8 are of the size of those on abdominal segments 4 and 1.

The ground color is a pale, delicate pea-green; most of the tubercles are green, but the large dorsal tubercles on first, fourth and seventh abdominal segments are now rose reddish; the others only faintly stained with roseate.

It thus appears that all the essential characters of the fully grown larva are assumed in the second stage, and at a period much earlier than in the larvæ of some, if not all, of the other Bombycine families. This acceleration of development of the adaptational characters of the larva seems to occur also in *Empretia*, and probably in *Lithacodia*, and is perhaps common to the group. Additional observations are, however, much needed on this interesting point.

The following description is drawn up from ten larvæ kindly sent me by Mr. Fred. B. Simpson from New York. It feeds on japonica, and will, he says, eat the wild rose.

Stage III.—Length, 4 mm. Body with the segments in this genus distinct. It is rather narrow and elongated, nearly three times as long as wide. The back of the body is well rounded, forming a slight approach to that of ordinary caterpillars; the segments convex, and the sutures between them deep and distinct; the dorsal region is narrower than the sides, which flare out somewhat; in transverse section the body is somewhat trapezoidal. The prothoracic segment forms a true hood, which is slightly bilobed on the front edge, and encloses the head when the latter is retracted. The head is moderately large, pale green, and the region of the mouth is darker, pale chestnut.

The three segments behind the first thoracic each bear a pair of large high pear-shaped or high conical bright pale coral-red tubercles, densely spinose and pappose. At the end of the body, on the three last segments, are three similar pairs of coral-red tubercles, those of the last pair being slenderer, more pointed, and projecting out backwards; they are also green, of the same hue as the body, but in the larger specimens they become red. Between these two sets of large red tubercles are five pairs of small green ones, which are one-third as large as the largest red ones; they are not situated quite so near together, and are all of the same size; the third pair are connected by a transverse greenish ridge; from this

ridge to the back of the second segment, or between the first pair of red tubercles is a broad, irregular patch of dull purple, interrupted between the second and third anterior red tubercles by a transverse green line.

On the posterior half of the body is a patch formed of three purplish patches connected together; the third and last of the three portions forming the patch, which ends before reaching the middle pair of the three posterior pairs of tubercles. The sides of the body fall away precipitously, spreading out a little at the base or edge of the creeping ventral disk. On this edge is a series of nine green pappose and spinose papillæ or tubercles, the anterior two or three and the last being very slightly larger than the middle ones. Between the ventro-lateral and subdorsal rows the sides are variegated with upright ridges connecting the lower and upper tubercles. The sides of the body are dark pea-green, and the dorsal region faintly yellowish green, the subdorsal papillæ being yellowish green and the lower ones dark pea-green.

In one slightly larger (4.5 mm. in length) the body above is stained less red and purple than usual, the posterior purplish patch not yet formed, and only represented by purplish points, while the third pair of anterior papillæ and the first and third pair of the posterior set are still green. Also the subdorsal line along the tubercles are whitish yellow.

It thus at this stage varies considerably in coloration and in the distinctness of the hues.

Stage IV.—Length, 7 mm. When in this stage it only differs from the smaller ones in the dorsal purplish patches being more greenish in the middle, and edged distinctly with darker and externally brighter tints. Each segment, also, covered by the purplish patches bears a pair of minute greenish warts, which are much less distinct in the smaller ones; sometimes two of these warts are connected by a greenish line. Also in this stage the last pair of dorsal papillæ are red, and the middle papillæ are stained with bright red on the inside at the base, sometimes the red stain being connected with the red border of the dorsal patch. In this and the next stage the body is somewhat higher over the thoracic region, falling away slightly posteriorly.

Last stage (V), fully grown larvæ.—Length, 12 mm. (The largest and most distinctly marked larvæ selected for description.) The body is of the same shape as before, *i. e.*, when one-half grown. The dorsal plateau is as wide as the body, the sides falling away rapidly from the edge of the plateau; the sides of the plateau are rounded over, not forming ridges. The two great patches on the yellowish plateau are pale purplish madder, darker on the edges, and edged with bright brick-red or Venetian red, while the papulæ are bright cherry or vermilion red. There is a faint, pale medio-dorsal line. The purplish patch begins on the front end of the second thoracic segment and contracts deeply between the second pair of papulæ and again between the third pair, ending suddenly in a mucronate point situated between the sixth pair of papulæ. The second patch begins at a point situated between the sixth and seventh pair of papulæ, contracts

narrowly between the ninth pair, ending just in front of and between the penultimate or tenth pair. The first patch then is composed of three sections or saddle-shaped dilatations, of which the last or third extends a little way down the sides of the plateau, and there are two divisions of the second patch, the first the larger, and extending down the sides of the plateau, but not so far as the third division of the first or anterior patch. Between the first pair of papule is a greenish median, transverse spot, and on each side of the first section of the purple patch are two greenish dots like a stunted exclamation mark. These dots appear to be modified surface dorsal piliferous warts, but they bear no hairs. A few fine piliferous tubercles are scattered along the sides of the body. On the middle section of the first or anterior purplish patch are four rounded, impressed, modified, greenish warts, and on the third section there are six of them. On the posterior or second patch the first and larger division bears four such round greenish spots, with a darker centre representing an aborted hair, and on the last division are two similar spots. The last two pairs of spots are connected by a faint line of the same color. The three anterior pairs of papule which increase in size to the third pair are all bright, delicate cherry or vermilion red. The three last pairs are of the same color, except the last pair which are green at base; of these three the middle pair (the tenth pair of all) are longest and highest, being twice as long and high as the ninth pair. The fourth and fifth pair are very small and green, while the sixth pair are somewhat larger than the two pairs in front, and the two pairs behind, and tinged with bright reddish. The papule are all densely spined, the spines stiff and sharp and blackish at the ends, greenish at the base. On each side, low down, is a row of nine small, spiny papule, rather difficult to detect as they are concolorous with the body. Directly below them are the minute, pale, circular spiracles. The papule are situated on a ridge, while the spiracles are just below it. Between the papule is a pale lemon-yellow streak. The plateau is yellowish green above and on the sides, while the sides are dark pea-green. The skin of the entire body is finely granulated.

This larvæ indicates in some points of its structure its descent and that of the group to which it belongs, from the *Attaemæ*; these points are the setiferous tubercles, and the distinctness of the segments from one another, the sutures between them being well marked. *Adoneta* is one of the more generalized forms, while *Limacodes (scapha)* and *Heterogenea* seem to be the most modified, specialized or aberrant forms. Hence *Adoneta*, etc., are more like the probable ancestors of the group than any other genus.

Several singular microgaster cocoons occurred on some individuals, being white and projecting vertically from the back.

RECAPITULATION OF THE MORE SALIENT ONTOGENETIC FEATURES.

A. *Congenital Adaptational Features.*

1. No tubercles on the prothoracic segment.
2. The dorsal tubercles on the second and third thoracic and first, fourth, seventh and eighth abdominal segments double the size of those on the other segments, the tubercles being already differentiated at birth.
3. The prothoracic segment not yet forming a hood, the head not retracted within it so readily as in the last stages.
4. The tubercles each bear only three three-forked glandular setæ.
5. The segments are more distinct than in the later stages.
6. The body is pearly white, slightly purplish on the back.

B. *Evolution of Adaptational Features.*

- 1 The body in Stage II assumes nearly the form and colors of the last stage, the tubercles being armed with numerous spines, and some of them tinted with red.
2. In Stage III, the colors and appearance of the full-fed larva are assumed.

LARVA OF PHOBETRON SP.

Received from Miss Soule, of Jamaica Plain, Mass., September 10, on maple. Length, 9 mm. Anterior pair of flaps (of which there are ten pairs, five pairs being larger than the others), spreading out on each side, and as broad at the end as long; those of the four other pairs directed backwards; those of the second pair are one-half as large as the third pair, and are flattened. The fourth pair are very small; the fifth pair slightly larger than the third. The ninth pair are elongate, conical pointed and pale in hue. The tenth pair are minute, directed horizontally backwards and pale yellow. The upper surface of the body is much flattened. The color of the body is pale sandy brown, becoming paler towards the end of the body. Though young it appears to be quite different from the ordinary larva of *P. pithecium*.

The spines and hairs of *Phobetrum pithecium* present some interesting peculiarities. Fig. 11, *a*, represents one of the flaps, which is connected with the body by a very slight attachment at *a t*, situated at the base of the flattened bilobed process, which is naked beneath; the free lobe is fringed with delicate plumose hairs; *b*, represents the end of one of the smaller flaps, clothed with plumose hairs and naked at the end, which bears a very long seta; *b'*, this terminal seta, enlarged still more, with a few thick spinulate setæ near the base.

Fig. 12, two of the plumose hairs from a flap; all of the other processes have similar hairs.

The last genus of the spinose Cochliopodids is *Isa* (*Sisyrosea*). Fig. 13 represents the end of one of the lateral tubercles of the first abdominal seg-

ments of *I. (Sisyrosea) inornata*. Fig. 14, *a*, end of the same still more enlarged containing the supposed venomous glands; *b*, a group of three minute spines at the base of a tubercle, two of them containing the nuclei of the poison-cells; *c*, the basal minute spines at the base of the adjoining tubercle, with the spinulated cuticle (*d*) of the skin of the body between them; *d'*, granulations of the skin, with two minute spines and a fine hair-like seta; *d''*, portion of the cuticle, with minute forked spinules and granulations; *p*, a hollow spine filled with poison.

THE EARLY STAGES OF LIMACODES SCAPHA HARRIS.

The young live on the under side of the leaf, eating holes out of the middle.

Stage II (?)—Length, 3 mm. On *Myrica* gale, August 4, from Miss C. E. Soule. The body is oval, much flattened compared with the full-grown larva, being of the shape of a flat iron, the back being much depressed instead of rising into a conical dorsal ridge as in the final stage. It is square or docked in front and pointed at the end of the body. It is greenish, with a slight amber-yellow tint; but the much raised thick rim or edge of the body is stained brick-red, both the outer and inner edge of the red portion being scalloped, while a reddish bridge is thrown across the depression just in front of the middle.

Stage IV, or that before the last.—Received, August 26, from Miss Soule. Length, 6 mm.; breadth, 3 mm. The body is still much broader and flatter above than in the full-fed worm; the dorsal surface is broader than the ventral, the sides overhanging the creeping disk, while the dorsal surface is broad and depressed, the sides rising or turned up somewhat, while the sides of the body are deeply hollowed in. The body is widest in the middle where there are two large, dark blood-red patches which touch each on the median line of the body. Near the end on each side of the body (on the third or fourth segments from the pointed end of the body) are two pairs of small dark-red spots, connected at the base on the reddish rim of the dorsal field; and on the first pair of spots at the base on the edge of the body is a clear white dot which extends underneath. The edge of the dorsal depressed surface is somewhat stained irregularly with dark blood-red; the red accentuated at intervals by four or five dark-red dots. On each side of the body are two alternating series of round areas, as if stamped into the skin. On each side of the body below are two rows of somewhat similar roundish impressed spots. On each side above is a row of nine chitinous crescent-shaped marks. These spots do not differ in hue from the body. The prothoracic segment or hood is reddish in front and the shoulder of the next segment is stained with red. The head is pale green, dark around the eyes and mouth.

The specimen described below agrees exactly with Harris' figure (Corr.

Pl. iii, Fig. 8). It was found on *Vaccinium corymbosum* at Providence, October 5.

Full-fed Larva.—Length, 15 mm.; greatest height, 7 mm.; breadth of body, 8.5 mm. The body is short and high, quadrangular in transverse section, bulging out a little near the creeping disk. The back slopes rapidly down from the middle to each end, which is acute, ending in a point or process, so that the caterpillar looks like a little rough skiff. The head end is a little truncated, the head not seen from above, while the posterior end is acutely pointed and held somewhat elevated from the surface. Each side of the broad flat back is sharply ridged, and on the outside on the lateral edge of the ridge is a row of eight small, square, brownish spots. The segments are flat and continuous, the sutures obsolete, so that neither above nor on the sides is the body segmented, a characteristic of the larvæ of this genus, which as regards the caterpillar is highly modified or specialized in shape and external structure. In the middle of the back the ridge is slightly swollen and inside are two large diffuse pale-lilac patches; there is a similar pair of patches near the end of the body. The head is brown and of the usual shape. The prothoracic segment or hood has a V-shaped fissure or opening in front; it is lilac above, greenish behind. On each side of the body above is a series of faintly impressed, oblong (vertically situated) impressed areas, each containing a round pale-brown scar. There is a row of scars below the spiracles, and a row of smaller scars along the edge of the bottom of the body. There are seven round pale-brown spiracles visible; the eighth, if present, I have been as yet unable to detect.

The larva of this species differs generically from that of *Lithacodia fasciola* in the very broad dorsal plateau, which is as broad as the body, the sides being perpendicular, and either full or hollow, this being dependent on the motions of the insect. The skin is smoother, less rough and granulated than usual, and there are in general no minute setæ or fine hairs, except a few scattered hairs near the edge of the creeping disk.

The peculiar shining, glistening green color is half way in hue between the color of the upper and under side of the leaf. There is a narrow, threadlike yellow dorsal line from which a fine yellow line passes off at right angles along the suture of three of the segments near the middle of the body. On the third and fourth abdominal segments the lateral ridge, which is well pronounced, is swollen and raised, and stained yellow, but tinged with deep blood red on the top of the dorsal ridge. On the seventh abdominal segment it is flattened and hollow, and there is a subtriangular hollow, pale, yellowish brown, edged with deep red. All the four subdorsal patches resemble the small sere and brown spots on the oak leaf, which are generally yellowish brown and reddish; the imitation in color, as in other Limacodid larvæ, being striking. The edge of the creeping disk is whitish yellow. The body ends in a short, conical, tail-like process, the tip of which is brownish, and on this process the two subdorsal ridges and the two lower yellowish-white lines above the

creeping disk meet. On each side of the dorsal plateau is an alternating row of impressed areas representing flattened and otherwise modified warts, and on the sides are the spiracles, which are round and colored like parchment. Below, alternating with the spiracles, is a row of minute sunken warts, and above, also alternating with the spiracles, is a row of ten oval or dumbbell-shaped pale spots, situated on a large subtriangular impressed field. This field is seen under the microscope to be granulated, while the surface of the body around them is singularly roughened with minute raised, curved or new-moon-shaped granulations.

LARVA OF *PACKARDIA ELEGANS* (PACKARD).

The larvæ of this species frequently occurred on the leaves of the wild cherry at Providence, in rather dense, dark pine woods near the banks of the Seekonk river, during the last two weeks of September. The flexible tongue-like tail, reminding one of that of *Parasa fraterna*, though not perhaps homogenetic with that, is a good generic character, and it may be an incipient deterrent movable organ serving to frighten away ichneumons and tachinas.

Full-grown Larva.—Length, 14 mm.; breadth, 5.5 mm. This larva is allied to that of *Limacodes fasciola*, but differs generically in the long tail-like prolongation at the end of the body. The body is oval, but longer and narrower than usual, and rather high, with a rather narrow but well-marked median plateau-like surface bounded by well-marked, distinctly scalloped ridges, which are stained whitish lemon-yellow. From this plateau the sides of the body fall rapidly off; the surface of each lateral region or declivity is steep and somewhat hollowed, and about twice as wide as the median plateau (in *L. fasciola* the plateau is about as wide as one of the lateral regions). The sutures between the segments are indistinct, not so well marked as in *L. fasciola*. Along the middle of the plateau is a row of pale, whitish-green, rounded spots which extend nearly to the whitish ridge, and are centred by a slightly raised, dark-green spot. It does not form a tubercle or flattened wart. On each side along the middle of the lateral region is a row of ten similar spots, and farther down is a submarginal row of irregular subtriangular lemon-yellow spots, each situated directly below the dark-green centre of the whitish spots above.

The sides of the body, viz., the margin above the creeping disk, are slightly scalloped (the drawing well shows this), the points of the scallops being under a high-power Tolles triplet seen to be well emphasized by a minute piliferous tubercle, a little larger than the other granulations which roughen the skin.

The end of the median plateau is greatly prolonged into a long, tail-like, flexible, fleshy, acutely conical granulated process which is stained cherry-red above, the only red on the body. The end of the creeping disk is provided with fine short hairs.

A moth appeared in the breeding box June 6, and another June 7; it rested on the sides, with its wings depressed and the abdomen raised in the air.

Cocoon.—Rounded oval, of the usual shape; length, 6.5 mm.; shorter diameter, 4.6 mm.

My larva and also some excellent figures, with details, agree with Mr. Dyar's description of the larva of *P. elegans* in *Can. Ent.*, Dec., 1891, 277.

I have two good figures by Mr. Bridgham of the larva of *P. geminata*, which agree well with Dyar's description in *Can. Ent.*, Dec., 1891, p. 277, except that the tail is not slightly tipped with reddish. It was found on the chestnut, September 16, and also on the wild cherry.

THE PARTIAL LIFE HISTORY OF LITHACODIA FASCIOLA (HERR.-SCHAEFFER).

I am indebted to Miss Emily L. Morton for the opportunity of studying the freshly hatched larva of this species, as about the middle of June she very kindly sent me the eggs from New Windsor, N. Y., which hatched out at Brunswick, Me., July 18 or 19.

Egg.—Irregularly oval; length, 1 mm.; thin, scale-like, and the shell very thin and transparent. As they had dried on the paper on which they were laid, it is impossible to see whether the shell is marked with polygonal areas or not.*

The Freshly Hatched Larva (Fig 15).—Length, 0.8 mm. The body is white, tinged with yellowish; and the head instead of being white, as in *Adoneta* and *Empretia*, is somewhat amber colored; the eyes are black and distinct; the body is about four times as long as thick and slightly thicker through the second and third thoracic segments than elsewhere. The thoracic legs are unusually small. There are no tubercles, and the large setæ appear to arise directly from the skin; there are two dorsal and two subdorsal rows, one of each on each side. The granular setæ (Fig. 15)

* I also received from Miss Morton the eggs of *Phobetron pithecium* and of *Eulea querceti*. Like those described in this paper, they do not present good generic or specific characters, enabling them to be readily identified. I give, however, the following descriptions of them.

Egg of Phobetron pithecium.—The sexes were mated July 3. The eggs are orbicular-oval, flat, scale-like, rather large and of a more definite shape than usual; 2 x 1.5 mm.; somewhat raised in the middle, but with very thin edges, resembling a shallow plate turned bottom-side up. Some fortunately laid on glass showed very plainly that the very thin shell is covered with irregular, usually elongated polygonal markings; here and there one being one-third smaller than most of the others. As usual they are laid in an irregular group, partly overlapping each other.

Miss Morton writes me that the males seek their mates between nine and ten o'clock in the morning, and that she never succeeded in mating a captive female at any other time. She adds that the larva will feed on the chestnut, maple, hazel, oak, wild cherry, and possibly on other trees.

Egg of Eulea querceti.—Quite regular orbicular-oval in outline; thin, scale-like; 2 x 1.5 mm.; the edge is quite definite, and the polygonal areas much as in those of *Phobetron pithecium*.

are large and unusually thick and stout, and are only slightly enlarged at the base; on one side of each seta at the middle is a short, obtuse turn, just beyond which it contracts, and the blunt end is forked; the forks, however, not spreading wide apart. They are all (those of both rows) alike in shape and size and length from the second thoracic to, and including, the ninth abdominal segment, and are about one-third as long as the body is thick.

The segments are distinct, and low down is a lateral series of minute papilliform tubercles, one to each segment, and bearing a single minute short hair.

This larva is very different from those of *Empretia* and *Adoneta*, and probably is a fair type of the young or freshly hatched larvæ of *Limacodes* and *Heterogenea*.

The young larva was found feeding on the under side of a leaf of the red maple at Brunswick, Me., August 12; it also occurred on the under side of the leaf of the wild cherry in September, at Providence, and I have received it from Miss Caroline G. Soule, of Jamaica Plain, Mass., where it was found September 4, feeding on *Carya tomentosa*.

Stage III (?).—Length, 5.5 mm. The shape of the body is like an inverted skiff, the flat dorsal keel being about half as broad as the whole body, which is oval in outline, the body ending behind in a dull point, which bears two bristles. The larva is pea-green, much darker than the under side of the red maple leaf, and a little lighter than the upper side. The head is pale green, the jaws dull amber. The crenulated ridge along the back is pale straw-yellow. There is a dorsal row of about eight roundish, pale straw-yellow spots. All the tubercles, which are concolorous with the body, bear short, stiff, dark bristles. There is a row of from six to eight faint greenish-yellow rounded spots along the slope of the back, outside of the crenulated yellowish line.

Stage IV (?).—Length, 7 mm. Body oval, flattened, in general rounded; the surface elevated into a dorsal region bounded by two keel-like ridges, the edge of each being serrated, each tooth bearing two obliquely situated short spines which are green tipped with brown, the keel itself being yellowish. Along the middle of the dorsal ridge is a row of ten whitish spots with a greenish centre. Each spot is accompanied in front by two lateral white dots. Outside and below each dorsal ridge is a row of ten large white roundish spots, with dark centres; below this row is a series of white dots, and near the edge of the upper side is a row of obscure white dots. The edge of the body seen from above is scalloped, and on each scallop is a row of laterally projecting minute green spines, the largest one of which is brownish. The body in general is pale green; the head paler, dark on the mouth parts, and the eyes are dark. The surface of the body above is roughly granulated.

Several larvæ living on the under side of the leaf of the wild cherry and chestnut occurred at Providence during the middle and last of September.

Last Stage.—Length, 12 mm.; width, 6-7 mm. The body is regularly

oval in outline, rounded in front, and behind slightly produced. The head is pale pea-green, the mandibles dark, the labrum whitish. The prothoracic segment is as usual without markings. The rest of the body is divided longitudinally into three regions: There is a median, elevated plateau-like region, bounded by a well-marked irregular ridge; from this ridge the body falls off rapidly on each side to the lateral ridge overhanging the creeping disk; the surface of each lateral region may be steeply inclined or somewhat hollowed out, as it depends on the movements of the larva. The segments are defined by well-marked sutures. The skin is very rough, the soft, fleshy rugosities standing well up, and the sides of the body are finely crenulated. The body is pale pea-green, the general tint being like that of the under side of the cherry leaf, but more yellowish. The rough edge of the plateau, *i. e.* the two parallel ridges bounding it, the surface of the plateau being level, and not hollowed, is lemon-yellow; these two lemon-yellow lines are wavy, and they connect in front on the second thoracic segment; but behind, on the last segment of the body, they do not quite meet. Along the middle of the plateau is a median series of eleven irregular roundish lemon-yellow spots centred by a depressed wart, each situated on a suture. On each segment and each side of the sutural spots, in the middle of each segment, is a pair of lemon-yellow dots. On each of the lateral slopes of the plateau are four rows of lemon-yellow spots, the highest and first being a row of minute transverse spots situated on the suture. Below this row is a series of large transverse oval yellow spots centred by a depressed dark-green point. This row is succeeded nearer the edge by a row of yellowish dots, two on each segment; one, the smaller of the two, situated on each suture. The fourth row is on the margin of the body, and is a broken series of short lines.

There is no red on the body. The end of the body is a rather narrow, obtuse, slightly upcurved portion, being the end of the dorsal plateau. There are no setæ or coarse hairs above, but around the lower edge of the body are sparsely scattered very short fine hairs. The spiracles are situated just above the edge of the creeping disk. *The dorsal setæ of the preceding stage are wanting in the final stage.*

A figure made for me, by Mr. Bridgham, of a larva found feeding by Miss Morton, September 4, on the walnut, in probably next to the last stage, represents bristles, distinct sutures, and the segments as convex, features which are not indicated in the full fed worm.

One example was ichneumoned. It will be noticed that in its last stage this species loses its slight armature of minute bristles; and it apparently has no use for them, since I have been struck with the resemblance in the shape and color of the larva to a simple slight fold in a leaf, so much so that it might readily be mistaken for such a bend in the leaf by a passing bird; and then the very sluggish motion of the creature would further aid in the deception.

RECAPITULATION OF THE MORE SALIENT ONTOGENETIC FEATURES.

A. Congenital Adaptational Features.

1. The larva is hatched without any tubercles.
2. The glandular hairs are of the same size and shape in the dorsal and subsdorsal rows; being short, with a tuft at the middle, and forked at the truncated end.
3. The body is more cylindrical than in the last stages and not skiff-like, and the segments are distinct and simple.
4. The body is at first colorless.

B. Evolution of Adaptational Features.

1. The body becomes skiff-like when 5.5 mm. in length.
2. The color is pea-green, like that of the leaf it feeds on, with straw-yellowish marks and spots.
3. The skin becomes rough and granulated, and the plateau distinctly marked in Stage III or IV.
4. In the last stage the minute spines disappear.

YOUNG LARVA OF HETEROGENEA SP.

Very near B.'s drawing, August 8, 1888, on the wild cherry. It must be that species, as both want the anterior median reddish dorsal stripe.

My specimen, found on under side of leaf of wild cherry, September, 1890, only differs from Bridgham's figure in wanting the row of small tubercles on each side; these may be developed in the penultimate stage, but my specimen is of the same length (5.5 mm. by 3.5 mm. wide). It is closely allied to if not the same as the *Heterogenea testacea* found on the beech. It differs from those, and an unpublished figure by Emerton, however, in the line from the front edge of the second thoracic segment to the cross being obsolete, and simply represented by a faint, small, transverse discoloration, where two are represented in Bridgham's Fig. A. The red Greek cross is not very well marked, as the arms of the cross are very broad and triangular, and the base does not reach the end of the body. But the colors are as in *H. flexuosa*, the general color purple madder, with a longitudinally oblong pale Venetian-reddish patch containing still paler spots, the whole margined with deep brick-red, and edged on the outside with yellow.

This and other *Heterogeneas* look just like a reddish patch often to be seen on the under side of some of the cherry leaves and afford remarkable examples of protective coloration.

FULL-GROWN LARVA OF HETEROGENEA SP.

Occurred on the under side of leaf of oak at Brunswick, Me., September 6 (Bridgham's MS. Fig. 273).

Length, 9 mm.; breadth, 5 mm. The body is broad, oval, somewhat flattened, with two narrow dorsal ridges, which are a little wider apart on the second thoracic segment, and in the middle of the body. The ridges are irregular, wavy, crenulated and lemon yellow, uniting on the last abdominal segment. From the ridges the sides of the body fall away at a low angle forming a gentle declivity, on which are two alternating rows of depressed lemon-yellow oval areas, bearing a minute depressed pit, a sunken piliferous wart, without the seta. A series of scattered very minute slender short hairs can be seen with a Tolles high-power triplet. On the second thoracic segment the ridge and space between is filled with bright red; in the middle is a sunken pit, containing a small pale wart, but not bearing a bristle. A larger subtrapezoidal red spot in the middle of the body is edged with lemon-yellow, but the tubercle in its centre is stained with reddish. Besides the median warts there are nine other green ones along the middle of the dorsal ridge, one to each segment. The segments are distinct enough to be counted. The general color is pea-green, slightly more yellowish than the under side of the oak leaf. The prothoracic segment is unspotted. The head is pale greenish, the mouth parts pale chitinous. The skin of the body is in general rough and corrugated, subgranulated.

FULL-GROWN LARVA OF HETEROGENEA (TORTRICIDIA) TESTACEA PACK.

The larva (a ♂) in shape much like that of the European *Heterogenea asella*, occurred September 8, on the under side of a beech leaf, at Brunswick, Me. It spun its cocoon on September 10, and the moth appeared on May 27 following.

Larva.—Length, 11 x 6 mm. Skiff-shaped, being oval in outline, with the front full and rounded, but also rather blunt at the end, not pointed. Dorsal surface full and convex, neither angulated nor keeled, as it is in *Limacodes scapha*. On the anterior and also the posterior third of the body are two nearly parallel, slight, irregular ridges, which are not so distinct in the middle of the back, and which send out a red line, and spreading out in the middle of the body form a broad red loop nearly reaching the side of the body. The ridge at each end is a rich, bright Venetian red, edged externally with yellow. The space between these ridges is filled in with pale Indian-red almost exactly of the color of the reddish-brown withered spots on the leaves of the same tree, as I especially noticed; the mark is, in other words, a large faded reddish blotch like a Greek cross, extending from end to end of the body, the lateral triangular expansion or arms of the cross nearly reaching the sides. There is a median dorsal row of impressed rounded warts, which do not bear bristles, for there are no fine hairs or setae on the body. From the dorsal ridges the sides of the body fall gradually away to near the edge of the body, where there is a much thickened rounded bead or ridge overhanging the edge of the creeping disk. On the sloping side are two rows

of impressed areas, the subdorsal consisting of a large transversely situated, acutely oval depression, one on each segment on each side of the body, and those of the second lower series are about one-third as large as the subdorsal ones. Low down on the side of the creeping disk is a row of small round impressed areas. In front the red top of the cross widens a good deal, ending in the front edge of the second thoracic segment; while at the end of the body, what corresponds to the foot of the cross is narrowed to an obtuse point. The skin is corrugated and somewhat granulated, and the body in general is pale green, being concolorous with the under side of the beech leaf.

On each side are two rows of depressed areas, the upper row of ten are oval, the smaller end pointing up, and the middle five on the purple madder spot or arm of the cross are longer and narrower oval than those in front or behind. The row of ten below are round sunken areas; still below, but quite near the second row, and alternating with those of the second row, is a series of ten minute button-like round depressed marks; also most distinct on the purple madder of the arms of the cross. The prothoracic segment and head are dull pea-green; the head a little paler and chitinous around the mouth-parts. The skin is rough, finely granulated and punctured, but bearing no setæ, except some sparse, minute, slender ones around the edge of the creeping disk.

The spiracles are situated just above the edge of the creeping disk.

The "frass" or castings are irregular, short, barrel-shaped pellets.

Two larvæ were found on the wild cherry in which the anterior median line is broken up into three reddish spots. In one specimen the reddish cross is much paler than usual.

(An unpublished figure by Emerton of a larva from Kittery, Me., August 27, 1867, is the same species.)

One found at Providence, on the oak, September 17, and figured by Bridgham (285), is like the one above described, but the head of the red cross is slenderer, and the whole cross is broader and larger in proportion to the body; the two arms of the cross are wider. In the middle of the body on the plateau is a square, pale, sere brown and green spot. Another specimen (Bridgham's Fig. 284) occurred September 16, on the witchhazel.

The larva of this species feeds on the under side of the leaf as do the larvæ of *Packardia elegans* and *Lithacodia fasciola*. They all eat brown patches here and there, or small holes in the leaf.

THE LARVA OF *HETEROGENEA FLEXUOSA* GROTE?

The following description was drawn up from a larva received from Mr. H. G. Dyar, of Rhinebeck, N. Y. Mr. Dyar writes: "I am not sure of the determination of *L. flexuosa*, as I never raised but one."

Length, 8 mm.; breadth, 4.5 mm. Body oval, thickest a little behind the middle of the body. The median dorsal plateau is not well marked,

the two ridges bounding it not being very distinct, but nearly obsolete. From the plateau, which is rather broad, the sides fall off at a moderate slope to the edge of the body. The width of the plateau is about the same as the body on either side. The body is pea-green, tinged with yellow in front. The second thoracic segment or front of the body as seen from above is mostly bright brick-red (Rubens' madder red), becoming darker in the middle; the red extends on each side to the front edge of the segment behind, and extends back to the great central reddish patch; it encloses a rather large, green, sunken, rounded wart, and two smaller, less distinct ones behind. There are no hairs or bristles on the body. The great central patch consists of a large central orange or pale Venetian-red spot extending along the plateau and including four median oval, round, sunken warts, with a flattened button-like wartlet in the centre, and four oval warts which are depressed and acute at the smaller end, each pair alternating with the median areas. This brighter red plateau spot is surrounded by a large pale purple madder patch forming a spot of the shape of an irregular Greek cross, which sends a broad arm to each side of the body, reaching to and including the side of the lateral ridge just above the creeping disk. The same patch sends a broad, triangular posterior arm along the plateau, spreading out each side of it to the end of the body and ending in a sharp point, which is at the foot of the cross. The entire cruciform patch is edged with carmine red, and outside of that, especially behind, with lemon-yellow.

LARVA OF HETEROGENEA (TORTRICIDIA?).

Occurred on *Vaccinium*. Length, 9 mm.; width, 4.5 mm. In outline seen dorsally to be oval-elliptical and produced behind into an upturned point, which is obtuse at the end, with two setiferous tubercles. The surface of the body is round and irregular, the back is raised into two great, longitudinal, irregular, fleshy ridges, with large, fleshy tubercles of the same color, bearing short, stiff, dark setæ which are pale at base and black at tip. Each of these ridges is irregularly stained with pale yellow. There are also two similar lateral ridges, the lowermost forming the edge of the creeping disk. They are broken up into a series of conical, setiferous, fleshy tubercles, but are not stained with yellow. The body is pale pea-green, the surface of the skin finely granulated. There are no reddish marks.

EXPLANATION OF THE PLATES.

PLATE I.

- Fig. 1. Freshly hatched larva of *Empretia stimulea*. (Much enlarged.)
2. Tubercle of the same, bearing three forked glandular hairs.

- Fig. 3. Spines, caltrops and cuticle of a fully fed larva of the same species. (For further explanations of this and other figures, see text.)
4. *Euclea querceti*, a dorsal tubercle with its spines.
 5. *Purasa chloris*, spines and spiny cuticle of fully grown larva.

PLATE II.

- Fig. 6. Freshly hatched larva of *Adoneta spinuloides*.
7. The same, drawn by J. Bridgham.
 8. Forked glandular hairs of the same, Stage I.
 9. A lateral anterior tubercle of the same species, Stage II.
 10. Tubercles and poison cells of the same species, last stage, with caltrops and cuticle.
 12. Plumose hairs of *Phobetron pithecium* taken from one of the lateral flaps.
 15. *Lithacodia fasciola*, freshly hatched larva.
 16. *Lithacodia fasciola*, glandular hairs, Stage I.

PLATE III.

- Fig. 11. *Phobetron pithecium*, a lateral flap; and seta at end of flap; last stage.

PLATE IV.

- Fig. 13. *Isa inornata*, a lateral abdominal tubercle.
14. End of the same still more enlarged, containing the poison, *p*.

(All the figures, except 7, drawn by the author with the camera.)

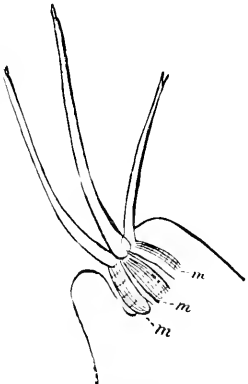

Fig. 2.

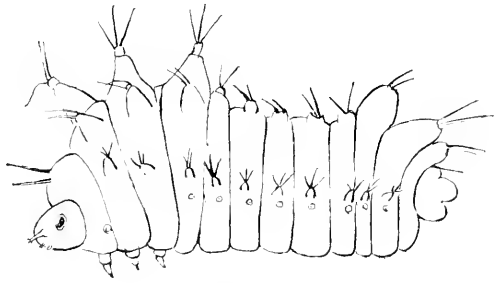

Fig. 1.

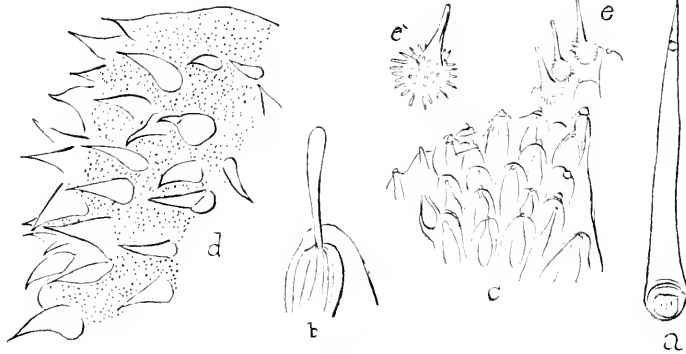

Fig. 3.



Packard del.

Fig. 4.

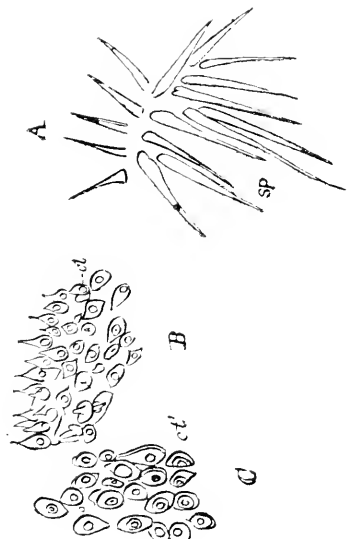

Fig. 5.

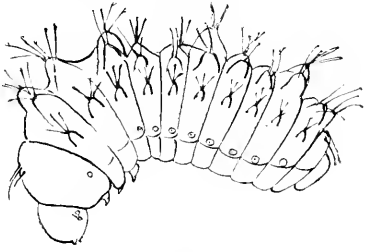

Fig. 6.

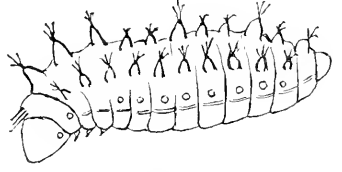

Fig. 7.

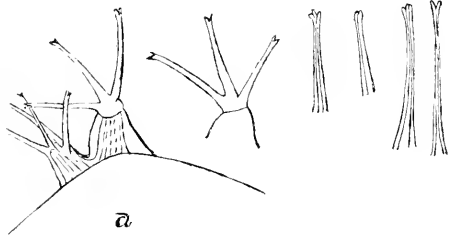

Fig. 8.

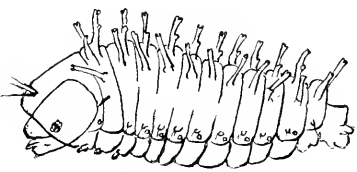

Fig. 15.

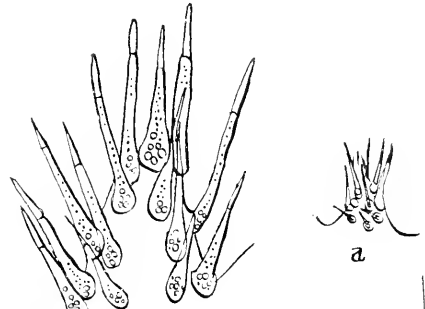

Fig. 9.

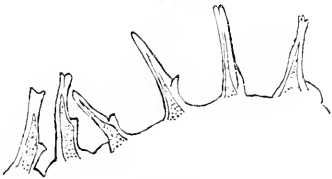

Fig. 16.

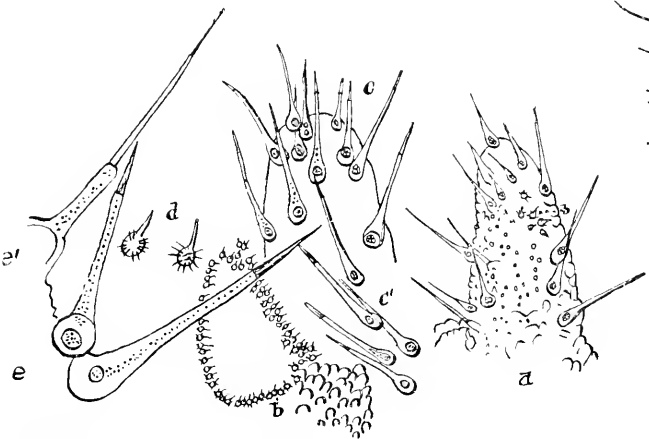

Fig. 10.

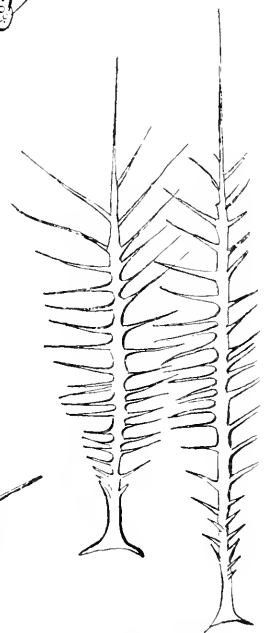

Fig. 12.

Packard del.

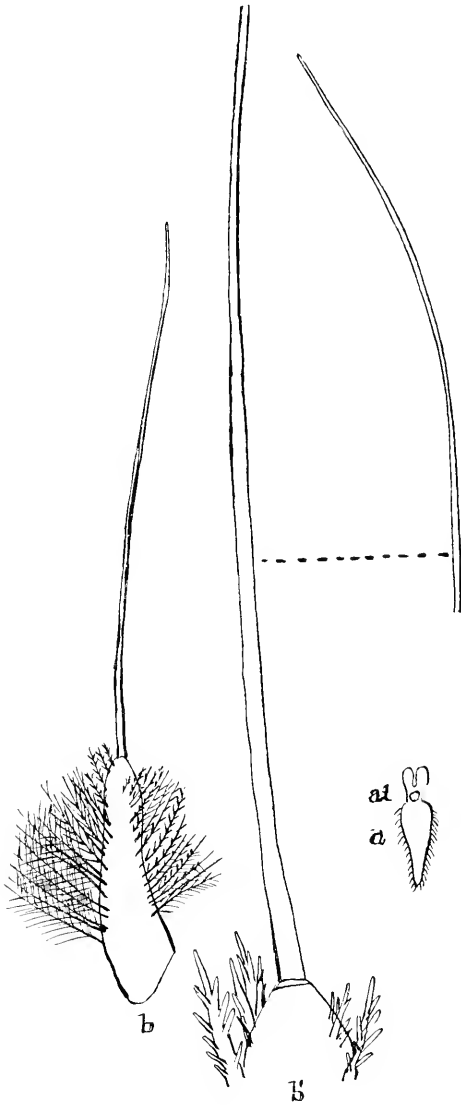
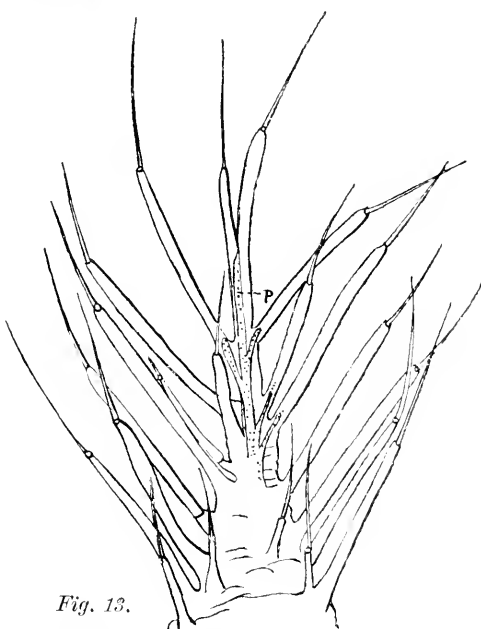
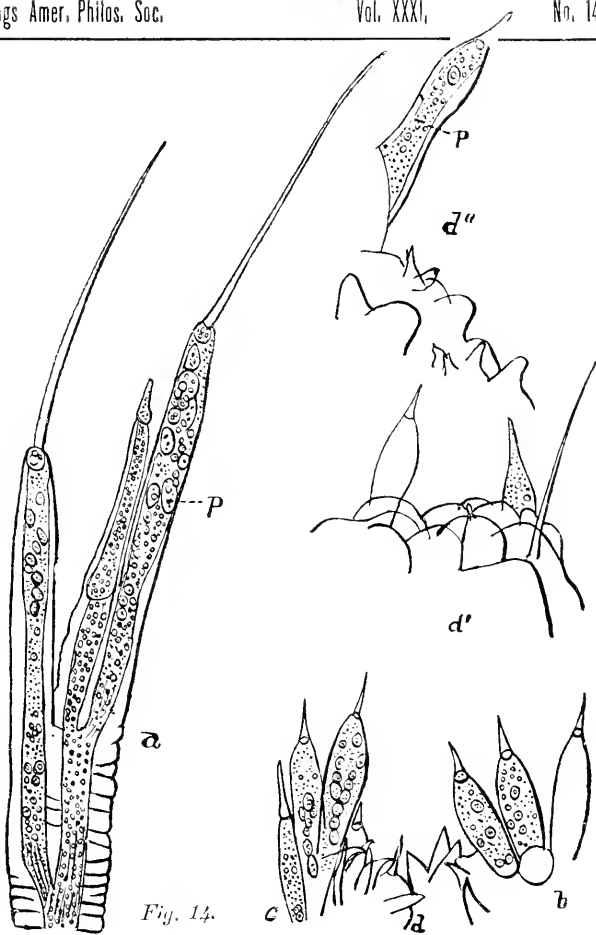

Fig. 11.

Packard del.

Larvæ of Cochliopodes and their armature.



Packard del.

Larvæ of Cochliopodes and their armature.

The Thyrsos of Dionysos and the Palm Inflorescence of the Winged Figures of Assyrian Monuments.

By Dr. Charles S. Dolley.

(Read before the American Philosophical Society, February 17, 1893.)

The generally accepted interpretation of the conical structure terminating the thyrsos, carried by Dionysos and his Thyasos, is that it represents the pine or fir cone.

Notwithstanding the number of authors, both ancient and modern, acquiescing in this interpretation, it seems to the writer entirely inconsistent with the present state of knowledge regarding the origin and spread of the Dionysos cult, and the significance of the Dionysiac mysteries. Brunck,¹ Welcker,² Smith³ and others regard the fir tree and its cones (*ζωνοφόρος*, *ζῶνος*, Theoph.) as being dedicated to Dionysos in consequence of the use of the cones and of the turpentine and resin obtained from the fir trees (*πεύκη*, Theoph.) in making wines.

Buchholtz⁴ comes to the same decision regarding the pine (*πίτυς*), basing his opinion upon the same line of reasoning, and the authority of Plutarch.⁵

The custom of flavoring wines with resinous substances was not confined to the ancients, but is prevalent in Italy and Greece to-day,⁶ and a careful review of the list of wines mentioned by Homer and earlier Greek writers, and the statements of Theophrastus, Dioscorides and Pliny regarding turpentine and resins, goes to show that there is no sufficient foundation for the above conclusion. It will furthermore be shown in the following examination of the subject, that such associations as exist between the Dionysos cult and the pine or fir tree are based upon considerations having nothing to do with wine.

The epithet or surname Bacchus (*βάκχος*, *Διόνυσος βάκχεϊος*) does not occur until after the time of Herodotus (484 B. C.). According to Lenormant,⁷ the "name is derived from the joyous cries with which the young god was accompanied, and it at first denoted the procession itself, or the song which was sung in it, before it was applied to the god." It seems possible that the term primarily referred to the thyrsos or rod carried by the god and each of his followers.

The drunken, riotous characteristics of the mysteries were probably

¹ *Griech. Anal.*, i, 42.

² *Griech. Götterleh.*, i, 424.

³ *Dict. Greek and Roman Antiq.*, Article "Thyrsos."

⁴ *Hom. Realien.*, i, 2, p. 266.

⁵ *Symp. quest.*, 3.

⁶ The modern Greek name *κρασὶ ρήτσινάτο* is applied to wines flavored with the resin of the Aleppo pine, *Pinus halepensis*, Mill. See Heldreich, *Die Nutzpflanzen Griechenlands*, pp. 14 and 41.

⁷ "Eleusian Mysteries," by Françoise Lenormant, *Contemp. Rev.*, Vol. xxxviii, p. 856

added to the original cult by the Phrygians and Phœnicians ;⁸ moreover, Euripides lays the scene of the Bacchanals in Thebes, a Phœnician settlement. Creuzer⁹ derives the word from the Phœnician and the Hebrew ככח (*bachch*). The religious ideas of the Phrygians were impressed directly upon the Greeks, but originally derived from the Syro-Phœnicians. With the Greeks the Dionysos cult had taken form and symbol long before the taste for artificially flavored wines arose, and, in fact, before wine became a common drink. The symbols came along with the cult, but having to a certain extent lost their original significance, so plain to the dwellers of Asia, the Greeks endeavored to account for them, as numerous writers have since, by giving them new and varied meanings. Thus the tall, slender fennel stalk, with a cluster of male date flowers fastened at the tip, as used by the Assyrian priests in the process of palmification, became the symbol of fructification in its widest sense. Carried in processions in honor of the deity of fruitfulness, it gave its name first to its bearers, and then to the god himself, and finally, when, far from its original home, the cult had lost its primitive purity, and its celebration had degenerated into the orgies of a frantic mob, the name (*βάζχος* = *rod*) came to signify the frenzy of intoxication.

But to revert to our objections to the plea that the pine cone was sacred to Dionysos because employed in flavoring wines, we find that the resinous taste was not by any means imparted to wines by means of the products of cone-bearing trees alone ; on the contrary, Theophrastus¹⁰ in his chapter on resins¹¹ refers to the relative values of the different varieties of gum resins, and places, far in advance of all others in public esteem, that produced by the terebinth (the turpentine tree of the Bible, *Pistachia terebinthus* L., or *τέρμινθος* of Theoph.), a tree common in the Greek islands and in Palestine, Egypt and North Africa, and belonging to an order of plants totally distinct from the conifers. The modern product of this tree is known in commerce as Chian turpentine, and comes mostly from the island of Chios, which excelled in the quality and quantity of this product in the time of Dioscorides and ancient Rome. The specific name had been changed, at the time of Dioscorides, from *τέρμινθος* to *τερπέβινθος*, and that writer refers to it as *ἐλατον μάστιγον*. According to Pliny¹² the terebinth was used in wine making, by boiling the new wood with the must. The same writer¹³ quotes Plautus as stating that the wines most highly esteemed among the ancients were those perfumed with myrrh, a product of two distinct plants, neither of them conifers. On the other hand, while the pitchy flavor was, without doubt, frequently produced by the resin of cone-bearing trees, such wines were not specially popular, nor were they considered wholesome, judging from the follow-

⁸ Gerhard., *Mythol.*, i, 495.

⁹ *Symbolik d. Mythol.*, iii, 125.

¹⁰ ix, 2, 7 and 3, 1.

¹¹ Cf. Koch, *Bäume und Sträucher des alten Griechenlands*, pp. 26 and 31.

¹² *Nat. Hist.*, xiv, 19.

¹³ xiv, 15.

ing statement : "The most wholesome wine of all is that to which no ingredient has been added when in a state of must ; indeed, it is still better if the vessels even in which it is kept have never been pitched." . . . "New wines seasoned with resin are good for no one, being productive of vertigo and headache ; hence it is that the name of *crapula* has been given equally to new resined wines and to the surfeit and headache which they produce."¹⁴ In the making of "crapula," Στρούβιλιτης οἶνος,¹⁵ pine cones (Στρούβιλος) were certainly employed, being steeped in the must, but it seems hardly probable that a custom not altogether prevalent, and producing a product regarded as unwholesome, should have given rise to the most common and characteristic Dionysiac symbol. Moreover, the resinous flavor was frequently produced in the wines by smoking either the grapes or the wine itself in wine lofts—*apothecais*¹⁶—in the smithies or the chimneys. The Libanian grape produced a wine having a natural odor of frankincense, and which was preferred in making libations to the gods.¹⁷ Rætian and Allobrogian grapes had naturally a strong flavor of pitch.¹⁸ At the time of Homer, Dionysos was unknown as the god of wine. According to Herodotus¹⁹ not only was the name of Dionysos, but also the various extraordinary rites accompanying his worship, introduced into Greece by Melampus.

Euripides in many places clearly points to a well-understood Eastern origin of the cult, thus :

"DION. And I have left the golden Lydian shores,
The Phrygian and the Persian sun-seared plains,
And Bactria's walls ; the Medes' wild wintry land
Have passed, and Araby the Blest ; and all
Of Asia, that along the salt sea coast
Lifts up her high-towered cities, where the Greeks,
With the Barbarians mingled, dwell in peace.
And everywhere my sacred choirs, mine Orgies
Have founded, by mankind confessed a God
Now first in an Hellenic town I stand."

Or again :

"But ye, who Tmolus, Lydia's strength, have left
My Thyasus of women, whom I have led
From lands barbarian, mine associates here,
And fellow-pilgrims ; lift ye up your drums,
Familiar in your native Phrygian cities."

Melampus is supposed to have received his knowledge of the cult from Cadmus, who, with the Phœnicians accompanying him to Bœotia, brought these rites either directly from Egypt or from Tyre.

General tradition points to the introduction of the Dionysiac mysteries

¹⁴ Pliny, xxiii, c. 24.

¹⁵ Dios., 5, 44.

¹⁶ Pliny, xiv, 16.

¹⁷ *Ibid.*, xiv, 22.

¹⁸ *Ibid.*, xiv, 3.

¹⁹ ii, 49.

into Greece from India—compare the Assyrian title of the sun god *Diannisu*, “judge of men” (Fox Talbot),—by way of Parthia and Thrace, and this seems to be confirmed by Strabo’s²⁰ assertion that all Greek music was of Thracian origin. The choragic monuments of Athens show the intimate relation of music and the worship of Dionysos. The worshipers of the god in Thrace were in fact known as Orpheans, and with them the thyrsos-tip represented no longer a date-palm inflorescence, and not yet a pine cone, but the heart of Dionysos-Zagreus, torn from the young god by the Titans.²¹

As to the thyrsos, its primitive use in the Dionysiac processions was that of a wand or staff, to be tossed by the hands or feet of the dancers ; thus :

“ PENTHEUS. The Thyrsus—in my right hand shall I hold it ?

Or thus, am I more like a Bacchanal ?

DIONYSOS. In thy right hand, and with thy right foot raise it.”

For this purpose the light stalks of the giant fennel, the *Náροδῆξ* of the ancients, *Ferula communis* L.,²² a native of the regions about the Mediterranean, were admirably adapted, their structure being of so fragile a character as to obviate any danger being done by such blows as might be given by the rioters, as has been pointed out by Féé.²³ The same plant, and probably for similar reasons, was associated with Silenus, the companion of Dionysos :

“ Venit et agresti capitis Silvanus honore
Florentis *ferulas* et grandia lilia quassans.”

Virg. Ecl., x, 25.

(Sylvanus also came with the rustic honor of his head
Shaking the flowering fennels and the large lilies.)

The custom of twining garlands about the thyrsos was but an imitation of nature. Pierre Loti, in his charming descriptions of Morocco, refers more than once to these gigantic fennels, spreading over the country in every direction, a “forest of yellow verdure,” . . . “the flower-clad stalks of which are like yellow trees, and which are *festooned* by the great white blossoms of the bind weed, such as we see in our gardens.” This very bind weed, *Convolvulus sapium* L.,²⁴ was used in decorating the bacchantes and their staves, together with the ivy, there being a great resemblance between the leaves of the two plants.

From the above and many similar considerations, we are led to believe that the early worship of Dionysos was free from the frenzied debauchery of later days, and that the god’s peculiar relations to wine were the result

²⁰ x, pp. 469-471.

²¹ Cf. De Gubernatis, *Mythologie des Plantes*, ii, p. 290.

²² Hierbach, *Flora Mythologica*, p. 67 ; Heldreich, *l. c.*, p. 40.

²³ Féé, *Flore de Virgile*, p. lvi.

²⁴ J. Murr, *Die Pflanzenwelt in der Griechischen Mythologie*, p. 235 ; Euripides, *Bacchicals*, 702.

of corrupting influences affecting the cult during its westward spread. According to Pindar,²⁵ Plutarch²⁶ and Appolonius,²⁷ instead of the wild and wanton Thyasos depicted by Euripides, who, "at the appointed hour, shoot their wild thyrsi in the bacchic dance," Dionysos was in the earliest times accompanied by the Graces, and near the grove of Pelops, at Olympia,²⁸ shared an altar in common with them. In fact, while tracing back the cult through Parthia and the East, we pass from the home of the grape to lands where wine was the product of the date, and if the cone-like structure tipping the thyrsos finally came to symbolize the bacchic and wine-loving attributes of Dionysos, it was through a substitution of the grape for the date, a combining of the Eastern symbol of fertilization with the garlanded rod of the dancers, and a failure to comprehend the significance of the cone-like thyrsos tip, which in reality originally represented the date inflorescence found in the hands of gods, priests and winged figures on Eastern monuments.²⁹

That the Greeks and Latins were for a long time at a loss properly to account for this cone-like tip, being in no position to understand the import which the male date-palm inflorescence and the process of palmification held in lands further to the East, where dates formed the staple article of food, is shown by the substitution of various plants for the cone. The shaping of ivy and vine leaves into conical form, or "entwining with leafy greens the blades of javelins,"³⁰ shows as little comprehension of the real significance of the thyrsos on the part of the Greeks, as well as the corruption into which the cult had fallen, as does the story of the death of Orpheus the poet-guardian of the bacchic mysteries, at the hands of the frantic throng of Ciconian matrons beside Hebrus' stream.

Without going into the question of the identity of Dionysos and Osiris,³¹ or of Dionysos and the Priapus of Lampsacus, there can be no question that the basis of Dionysos worship was the belief in his universal quickening or procreative powers. The similarity of Osiris and Dionysos worship, the association of Dionysos with Demeter and the various symbols of his worship—phallus, serpent, bull, goat, fauns, satyrs, and the seasons of the year devoted to his festivals—all go to confirm the conclusion that the original cult rested entirely upon the personification or deification of the active propagative or creative powers of living nature. It is a significant fact that the Greeks held and still hold that pulverized date seeds have the property of provoking and facilitating parturition.³²

²⁵ *Ol.*, xiii, 5-10, 20.

²⁶ *Quaest.*, Gr., 36.

²⁷ *Rhod.*, iv, 421.

²⁸ *Pausanias*, v, xiv, or Taylor's transl., ii, p. 42.

²⁹ Cf. Edw. B. Tylor, "The Winged Figures of the Assyrian and Other Ancient Monuments," *Proc. Soc. of Biblical Archeology*, Vol. xii, pp. 383-393.

³⁰ Ovid, *Metam.*, xi, 27, 28; iii, 667.

³¹ Cf. King, *The Gnostics and Their Remains*, 2d ed., 1887, pp. 321-323.

³² *Grisard et Vanden Berghe, Les Palmiers Utile et leurs Allies*, Paris, 1889, p. 146.

In early art we find Dionysos frequently represented in association with the palm tree, or its conventionalization, the palmette.³³

At a later date, we find associated with the god some thirty odd plants, chief among which are the ivy, the silver-leaved poplar, the grapevine, the myrtle, the fig, the bind weed, etc.

Most of these plants, from the damp, shady character of their habitat, or from their productiveness, were held to be symbolic of the dews or moisture so essential to vegetation.

The aphrodisiac and stimulating qualities of wine naturally led to the placing of the vine among the plants symbolic of the quickening, rejuvenating god. Certain plants evidently refer to the soft, florid skin of the god, and to his general effeminate character.

In all the symbols of Dionysos, we find some obvious motive, except in the case of the fir or pine cone, and we cannot admit any force to the argument of Murr, Bœtticher and others, that the association of the pine with the god may be traced to the Corinthian myth of Pentheus, hiding among the branches of a pine tree from the frenzy of his mother Agave and the furious bacchantes :

“PEN. Well said : against a woman who would fight?
I'll hide my-elf upon some shady pine.”³⁴

It is curious that Milman, in translating this passage, calls the tree an ash, by what authority I cannot even surmise. In Paley's text the word ἐλάτρηξ is used to indicate the tree, *i. e.*, the silver fir, *Pinus picea* (distinguished by Theophr. as ἑλ. ἄρρηγ and ἑλ. θύλιζα, probably *Pinus abies* and *P. picea*,³⁵ but oddly enough this word was also used to refer to the young bud of the palm.

Neither can any inference regarding the origin of the thyrsos tip be drawn from the use of pine wood in the making of statues of the god, since Pausanias³⁶ describes the head found by the Methymnean fishermen, and declared by the Pythian deity to be a representation of Bacchus, as being made of olive wood. No one would, however, care to argue that the olive should, on this account, be considered a Dionysiac symbol. It is much more probable that the association of the pine with Bacchus was based upon the gathering of the throngs upon the pine-clad hills :

“DION. There's not a woman of old Cadmus' race,
But I have maddened from her quiet house ;
Unseemly mingled with the sons of Thebes,
On the roofless rocks, 'neath the pale pines they sit.”

³³ I do not agree with Goodyear in the belief that the palmette is derived from the lotus or any other motive than the palm.

³⁴ Cf. translation, by James Thorold Rogers, of Euripides' *Bacchantes*.

³⁵ See Daubeny, *Trees of Ancients*, p. 26.

³⁶ x, c. 19 ; Taylor's translation, Vol. iii, p. 152.

Or the customary use of pine torches in the Orgies :

“CHOR. The while the frantic Bacchanal,
The beaconing pine torch on her wand,
Whirls around with rapid hand.”

Or :

“TIR. As him shall we behold on Delphi's crags,
Leaping, with his pine torches lighting up
The rifts of the twin-headed rock ; and shouting
And shaking all around his Bacchic wand
Great through all Hellas.”

It was, as Dyer points out,³⁷ not at all uncommon for the priests of the temples “to combine and maintain with equal hand the various cults of various divinities centred there.” There was an early brotherhood of this kind established between Dionysos and Apollo, accompanied at times by an exchange of attributes and symbols, as is done by Æschylus when he sings :

“Apollo, ivy-god and prophet bacchanal.”³⁸

Or by the words of Euripides :³⁹

“Lord Bacchus, lover of the laurel tree.”

We see the blending of the Apollo and Dionysos cult in the appellations *Dionysos melpomenos*⁴⁰ and *Apollo Dionysodotos*. In the frequent transfer of insignia of one god to another, the tripod, originally a bacchic symbol, is permanently turned over to Apollo—*χορηγικὸν τρίποδός ἐξ Διονυσίου*, “dedicated to a god by victorious choruses”⁴¹—although given as a prize at the festivals of Dionysos in the Attic dithyrambic contests⁴² and we find it associated with the vine on the shields of warriors, pictured on certain Greek vases.⁴³ Again Bacchus was worshiped in the shape of Apollo's bull,⁴⁴ as at Elis, *ἄλιε τὰ ὄρε*,⁴⁵ or in turn lends his crown of ivy to Poseidon.⁴⁶

Apollo as the god of light, Dionysos as the earth god, combine the attributes of light, heat and moisture, the essentials of all organic life. We can, therefore, understand the close relation of their cults, and explain the presence of a date palm tree alongside the oracle of Apollo.

³⁷ *Studies of the Gods in Greece*, Macmillan, 1891, pp. 29-36.

³⁸ *Æschylus Tr.*, 394 ; cf. Macrobius, *Saturn*, 18, 6.

³⁹ Macrobius, *Saturn*, 18, 6.

⁴⁰ Pausanias, i, 2, 3, 4 ; xxxi, 3.

⁴¹ Gerhard, *Ausdrucksene Griechische Vasenbilder*, etc., i, p. 115 ; cf. Muller, *Der tripod delphico*, p. ii ; *Amalthæa*, i, s. 127.

⁴² Athen, ii, 37, *ὑπὸ τῆς ἰσχυρίας ἐν Διονυσίῳ*, “the festival of victory.”

⁴³ Gerhard, *l. c.*, Tab. xxxi.

⁴⁴ Gerhard, *l. c.*, p. 114, Tab. xxxii.

⁴⁵ Plut. *Quæst. Gr.*, 36 ; *Historia Natorum*, pp. 33, 66 ; Creuzer *Symbol*, iii, 87-95.

⁴⁶ Gerhard, Tab. x ; Paus., vii, 20, 1 ; iii, 24, 6.

The date palm, like the Dionysiac cult, was unknown to the early Greeks, to which Victor Hehn⁴⁷ refers as follows: "The *Iliad* never mentions the palm, which was as foreign on the Anatolian coast as in Greece proper; but in the oldest and most beautiful part of the *Odyssey*, the palm at Delos is described in words that express the admiration excited in the Greeks of the Epic period by a figure so novel and strange in the vegetable world. Ulysses has approached Nausicaa on the strand, and flatteringly beseeches her assistance:

" 'Never, I never viewed till this blest hour
Such finished grace! I gaze and I adore!
Thus seems the palm with stately honors crowned
By Phœbus' altars; thus onlooks the ground;
The pride of Delos. (By the Delian coast
I voyaged, leader of a warrior host;
But ah, how changed; from thence my sorrow flows;
Oh fatal voyage, sum of all my woes.)
Raptured I stood, for earth ne'er knew to bear
A plant so stately, or a nymph so fair.'

The far-traveled Ulysses had nowhere else on earth seen a tree like this, to the slender form of which he compares the figure of the royal maiden, just as Solomon does in his song, 'This thy stature is like to a palm tree,' and as the daughters of kings in the Old Testament bear the name of *Tamar*, the date palm. The palm tree, the pride of Delos, is also mentioned in Homer's hymn to the Delian Apollo; at its foot, clasping its stem with her arms, Leto was said to have given birth to her glorious son. The fame of the Delian palm grew with the increasing fame of the island, both as a resort of Apollo's pilgrims and as an emporium, especially as its fame had been echoed in the *Odyssey*. In later times, palm leaves were used at the four great festivals as symbols of victory. They were sometimes worn as wreaths on the head, sometimes carried in the hand. . . . In the middle of the seventh century B. C., the tyrant Kypselus, ruler of semi-Oriental Corinth, dedicated a bronze palm tree to the temple at Delphi, where there were no living palms. . . . The Athenians also erected a bronze palm tree at Delphi in honor of their double victory on the Eurymedon, and another at Delos through Nikias. Palms are found figured on the coins of Ephesus, of Hierapytna and Priansus in Crete, of Karystos in Eubœa, and on painted vases."⁴⁸

From the evidence before us, I am convinced that the conical flower cluster of the palm, as conventionalized in sculpture, and as the thyrsus tip, was mistaken by the later Greeks for the pine cone, and that they and subsequent writers have been ignorant of the peculiar relations of the date palm to the primitive Dionysiac cult.

⁴⁷ *Wanderings of Plants and Animals from their First Home*, by Victor Hehn, London, 1855, p. 201.

⁴⁸ Cf. Imhoff Bloomer and Otto Keller, *Thier- und Pflanzenbilder auf Münzen und Gemmen des Klassischen Altertums*, Pl. i, Fig. 8; ii, 13; x, 2-1.

*Observations on the Psoas Parvus and Pyramidalis. A Study of Variation.*By *Thomas Dwight, M.D., LL.D.,**Parkman Professor of Anatomy at Harvard University.**(Read before the American Philosophical Society, March 17, 1893.)*

The only anatomist who has made observations as to the presence or absence of the psoas parvus on a really large scale is the late Prof. Gruber, of St. Petersburg. After him, at a considerable interval, comes Mr. Hallet, and again, at an interval, Mr. Perrin. So far as I am aware no other anatomist has published observations sufficiently numerous to discuss.* As evidence that this deficiency really exists, I may refer to the zeal with which Theile's results on 20 bodies are quoted.

Perrin † found the psoas parvus in 32 of 112 subjects. Of these 32, 21 were males and 11 females. He states that the sexes were about evenly divided in the whole number examined. He gives no details as to the occurrence of the muscle on one or both sides.

Hallet ‡ gives the results of two years' observations in the dissecting room at Edinburgh, on about one hundred subjects each year. In his first set of observations the psoas parvus was more frequently present than absent, 61 to 54, and this proportion was preserved throughout the second hundred subjects. He remarks that when it is present it is most frequently found on one side, and that the right one. "In the first hundred subjects dissected it was found as often deficient in the female as in the male, but in the second hundred it was more frequently present in the proportion of seven to six."

We come now to the only satisfactory statistics, those of Gruber. § He gives first a series of observations of both sides of 450 bodies, of which 300 were male and 150 female. He made later observations for a particular purpose on 300 subjects in which the sexes were equally divided. The close correspondence between these two series is very remarkable.

FIRST SERIES.

	300 MALE.	150 FEMALE.	450 OF BOTH SEXES.		
Present on both sides. . . .	142 = 47.3 %	56 = 37.3 %	198 = 44 %		
Present on neither side. . .	111 = 37	72 = 48	183 = 40.6		
Present on right side	} 47 = 15.7	} 22 = 14.7	} 69 = 15.4		
only.				22	33
Present on left side				} 11	} 36
only.	25				

* This paper was read December 28, 1892, at the meeting of the Association of American Anatomists at Princeton. The context will show that one addition has been made since the reading.

† *Medical Times and Gazette*, 1872.

‡ *Edinburgh Medical and Surgical Journal*, 1848, Vol. i, and 1849, Vol. ii.

§ *Beobachtungen aus der menschlichen und vergleichenden Anatomie*, Heft 1, 1879. I have transposed Gruber's figures so as to show the presence rather than the absence of the muscle, and have substituted percentages for his rather crude proportions.

SECOND SERIES.

	150 MALE.	150 FEMALE.	300 OF BOTH SEXES.		
Present on both sides.....	70 = 46.6%	59 = 39.3%	129 = 43%		
Present on neither side....	56 = 37.3	69 = 46	125 = 41.6		
Present on right side	} 24 = 16.1	} 10	} 21		
only.....				} 22 = 14.7	} 46 = 15.4
Present on left side					
only.....	13	12	25		

The percentages are so nearly alike that there is no occasion to combine the series. The subjects came from all parts of Russia, and were mostly Slaves. The following results are self-evident: 1. That, at least on one side, the muscle is more frequently present than wanting, although in more than half the cases it is wanting on at least one side. 2. That it is more common in man than woman. 3. That the two sides are alike very much more often than unlike. This is directly contradictory of Hallet's results. 4. That practically it is found as often on one side as on the other.

Since this paper was first read the report of the Committee of Collective Investigation of the Anatomical Society of Great Britain and Ireland has appeared.* It shows that 457 bodies were examined and that the muscle was wanting in 270 (59 per cent.), that it was present on both sides in 139 (30 per cent.), on one side in 48 (11 per cent.). It was found only on the right side 27 times against 21 on the left. It was therefore more often wanting than present. The sex was stated only in 174 instances. Both muscles were wanting in 54 per cent. of the males, and in 65 per cent. of the females.

The observations about to be reported were made at the Harvard Medical School. Those on negroes are not included in any series. As it often happened that the observation on one side of a subject had been neglected, or for some reason had to be discarded, I give first a series of observations in which only the number of sides of bodies is considered. It comprises 608 sides, divided into 299 right sides and 309 left sides, and also by the sexes. It shows that considering sides only, the muscle is more often wanting than present; that it is more common in man than in woman, and that there is little difference between the sides.

FREQUENCY OF PSOAS PARVUS IN 608 SIDES.

	RIGHT.	LEFT.	TOTAL.
<i>Male</i>Present	89	88	177
Wanting	102	121	223
Total.....	191	209	400
Per cent. present.....	46.5	42.1	44.2

* *Journal of Anat. and Phys.*, Vol. xxvii, January, 1893.

	RIGHT.	LEFT.	TOTAL.
<i>Female</i>Present	33	30	63
Wanting	75	70	145
Total.....	108	100	208
Per cent. present.....	30.5	30	30.2
<i>Both Sexes</i>Present	122	118	240
Wanting.....	177	191	368
Total.....	299	309	608
Per cent. present.....	40.8	38.1	39.4

The next table shows the results of observations on both sides of two hundred and fifty subjects.

PSOAS PARVUS. RECORDS OF BOTH SIDES OF 250 SUBJECTS, 165 MALE, 85 FEMALE.

	MALE.	FEMALE.	BOTH SEXES.
Present on both sides.....	60 = 36.3%	20 = 23.5%	80 = 32%
Present on neither side....	84 = 50.9	53 = 62.3	137 = 54.8
Present on right side only.....	14 } 21 = 12.7	5 } 12 = 14.1	19 } 33 = 13.2
Present on left side only.....			
Total.....	165 = 99.9	85 = 99.9	250 = 100.0

This shows the muscle decidedly less frequent than Gruber found it, and a little more frequent than would appear from the English observations; thus suggesting the influence of race.

In order to study the relative variability of muscles, to ascertain whether the presence of one occasional muscle renders the presence of another more probable, the pyramidalis was chosen as a starting point. It was chosen because it is generally held that while it is present in a large majority of instances it is not uncommonly wanting. Though this impression is, I believe, general, there is, so far as I know, no large series of observations on the pyramidalis excepting Hallet's. In his two hundred subjects he found it wanting in the proportion of once in nine or ten.* In the following table of observations at the Harvard Medical School, individual sides only are considered.

PYRAMIDALIS IN 673 SIDES.

	RIGHT.	LEFT.	TOTAL.
<i>Male</i>Present.....	180	189	369
Wanting.....	45	36	81
Total.....	225	225	450
Per cent. present.....	80	84	82

* *Loc. cit.* It is worthy of notice that in his first hundred it was wanting once in every three subjects, and once in every fifteen in his second hundred.

	RIGHT.	LEFT.	TOTAL.
<i>Female</i>Present.....	80	83	163
Wanting.....	34	26	60
	—	—	—
Total.....	114	109	223
Per cent. present.....	71	76.1	73
<i>Both Sexes</i>Present.....	260	272	532
Wanting.....	79	62	141
	—	—	—
Total.....	339	334	673
Per cent. present.....	76.6	81.4	79

The above table of sides only shows the muscle present only in 82 per cent. of the male sides, in 73 per cent. of the female, and in 79 per cent. of those of both sexes, which, however, were unequal. It was somewhat more common on the left.

The next table shows the results in the same series of two hundred and fifty subjects which was used for the *psoas parvus*.

PYRAMIDALIS RECORDS OF BOTH SIDES IN 250 SUBJECTS, OF WHICH 165 WERE MALE AND 85 FEMALE.

	MALE.	FEMALE.	BOTH SEXES.
Present on both sides.....	125 = 75.6%	58 = 68.1%	183 = 73.2%
Present on neither side...	25 = 15.1	22 = 25.9	47 = 18.8
Present on right side only.....	5	0	5
Present on left side only.....	10	5	15
	15 = 9.0	5 = 5.8	20 = 8.0
	—	—	—
Total.....	165 = 99.7	85 = 99.8	250 = 100.0

This shows, in addition to what was shown by the preceding table, that the two sides were alike in 92 per cent.

We must now subdivide this series into smaller groups according to the presence or absence of *pyramidalis* and *psoas parvus* considered collectively.

RECORDS OF BOTH MUSCLES ON BOTH SIDES IN 250 CASES, OF WHICH 165 WERE MALE AND 85 WERE FEMALE.

GROUP.	SEX.	NUMBER.	PER CENT.
A. <i>Pyramidalis</i> and <i>psoas parvus</i> on both sides.	Male.....	48	29
	Female.....	16	18.8
	Both sexes.....	64	25.6

GROUP.	SEX.	NUMBER.	PER CENT.
B. Pyramidalis on both sides. Psoas par- vus on one side.	Male.....	18	10.9
	Female.....	9	10.5
	Both sexes.....	27	10.8
C. Pyramidalis on both sides. No psoas parvus.	Male.....	59	35.7
	Female.....	33	33.8
	Both sexes.....	92	36.8
D. Pyramidalis on one side. Psoas par- vus on both sides.	Male.....	4	2.4
	Female.....	0	0
	Both sexes.....	4	2.4
E. Pyramidalis on one side. Psoas parvus on one side.	Male.....	1	.6
	Female.....	1	1.1
	Both sexes.....	2	.8
F. Pyramidalis on one side. No psoas parvus.	Male.....	10	6
	Female.....	4	4.7
	Both sexes.....	14	5.6
G. No pyramidalis. Psoas parvus on both sides.	Male.....	8	4.8
	Female.....	4	4.7
	Both sexes.....	12	4.8
H. No pyramidalis. Psoas parvus on one side.	Male.....	2	1.2
	Female.....	2	2.3
	Both sexes.....	4	1.6
I. No pyramidalis. No psoas parvus.	Male.....	15	9.6
	Female.....	16	18.8
	Both sexes.....	31	12.4

These tables show, as would naturally be expected, that the largest group (C) is that of two pyramidales and no psoas, and that this is the largest in either sex. For the next largest groups we have to examine the sexes separately, for we find that 29 per cent. of the men (A) have all four muscles, while precisely an equal number of women (18.8 per cent.) (A

and I) have all four, and none of the four. Only 9.6 (I) per cent. of the men have all four wanting.

By way of a more exact method of determining what relation there may be between the presence or absence of one muscle and that of the other, I have put together all the cases of presence of both pyramidales, groups A, B and C, into one series, and reckoned the percentages of instances of a *psaos parvus* on both sides and on neither side, to compare them with the percentages of the normal series.

We find 125 men and 58 women, 183 in all, having both pyramidales; of these 48 men and 16 women have the *psaos parvus* on both sides. Calculating the percentages we find that 38.4 per cent. of these men, 27.6 of the women and 34.9 of the whole, have the *psaos parvus* on both sides, against 36.3, 23.5 and 32 respectively as percentages of the whole series of 250. We find, therefore, that a subject with two pyramidales is a little more likely to have the *psaos* on both sides than one which has not. The next step is to take as a basis the cases of no pyramidalis, and to find whether in them the percentage of *psaos parvus* on both sides is different from that of the entire series. We find that 25 men and 22 women, 47 in all, had no pyramidalis; of these, 8 men and 4 women, 12 in all, had the *psaos parvus* on both sides, giving percentages of 32, 18.4 and 25.5 respectively, against 36.3, 23.5 and 32 in the entire series, showing that subjects with no pyramidales are less likely to have the *psaos parvus* on both sides than others. Thus we seem to have found a tendency, though a slight one, in variations by excess and variations by defect to go together respectively.

By way of further comparison I have counted the number in these 250 subjects in which the *palmaris longus* was known to be absent on both sides. I find this is recorded in 21 cases, and very probably occurred in some others. Let us see whether in these 21 cases there was a more frequent deficiency of either pyramidalis or *psaos parvus* than one would expect. We find nothing of the kind. As for the pyramidalis we find it was wanting in three cases only on both sides and once on one side. The *psaos parvus* was present on both sides seven times, almost precisely the percentage of the series of 250.

Finally I found among these 250 cases, 12 in which a *sternalis* was present on one or both sides (twice on both sides and ten times on one). This is what may be called an anomaly by excess. Let us see whether the series of subjects presenting it was marked by more than ordinary frequency of the pyramidalis and *psaos parvus*. The result is certainly remarkable, for it is the very reverse of what might be expected. In these 12 the pyramidalis was wanting on both sides in 4, and on one side in 3, leaving it therefore present on both sides in only 5. The *psaos parvus* was more normal, being present on both sides in 5, on one side in 1, and wanting in 6. If we take these two muscles together we find that both were absent on both sides 3 times, a percentage of 25, which is about twice that in the entire series. It cannot be denied that this series of twelve

subjects with *sternalis* is too small, and yet there is some reason to think that a larger series would give the same result only more strikingly. Thus there are three other cases of *sternalis* which could not be included, because in each the record of one *psaos* was wanting. The first had 2 *pyramidales*, one *psaos* was wanting, the other unaccounted for; in the second and third both *pyramidales* and the recorded *psaos* were wanting. As we have found that the two sides generally agree it is probable that the unrecorded *psaos* was in all these instances wanting. In any case if these could have been added to the series they would materially have diminished the frequency of *psaos parvus* and *pyramidalis* when the *sternalis* was present. The criticism may be made that the *sternalis* should not be reckoned as an instance of excessive differentiation, for it is found with abnormal frequency in anencephalous fetuses and there is reason in some cases at least to look upon it as a displacement of some fibres of the *pectoralis major*. It is to be remarked, however, that it is in these monsters, rather than in adults, that the deficiency of the *pectoralis* is common. No one would think of including them in a series for the study of the frequency of variations. In normal bodies the *sternalis* may, I think, be called an anomaly by excess.

These two sets of cases, namely those of absence of the *palmaris longus* and presence of the *sternalis*, the latter especially, tend to disagree with the conclusions reached on the series of the *psaos parvus* and *pyramidalis*. None the less I am disposed to allow the series of *psaos* and *pyramidalis* a certain weight. But granting that there is a tendency for variations by excess and deficiency to go together respectively, the fact seems to be that the tendency is a slight one and that probably the cause, whatever it may be, that determines the differentiation of muscles must be considered as acting in most cases on each independently of the others.

Again the only large series of observations bearing on this point is by Gruber. It deals with the *psaos parvus*, the *palmaris longus*, and the *plantaris* of 300 subjects equally divided between the sexes. His system of tabulation is not easy nor altogether satisfactory. He discusses the relative frequency of defect of these muscles, but apparently from rather a different standpoint. In no case were all three muscles wanting on both sides. In three cases only were two of them wanting in both sides and one on one side. Absence of *palmaris* and *plantaris* in the same subject was also very uncommon. In two cases both *palmares* and one *plantaris* were wanting. In no case, apparently, were both wanting on both sides.

On a New Method of Determining the General Perturbations of the Minor Planets.

By W. F. McK. Ritter, of Milton, Pa.

(Read before the American Philosophical Society, March 17, 1893.)

In finding the general perturbations of the minor planets the special difficulty arises from the large eccentricity and inclination of these bodies. The methods used in case of the major planets fail when applied to the minor, on account of want of convergence in the series. Astronomers were content, therefore, for a long time, with computing the special perturbations of these bodies from epoch to epoch. Hansen finally succeeded in effecting a solution of the problem, and his work entitled, *Auseinandersetzung einer Zweckmässigen Methode zur Berechnung der Absoluten Störungen der Kleiner Planeten*, contains all the formulæ necessary in the cases thus far occurring.

Instead of determining the perturbations of the coördinates, rectangular or polar, or of finding the variations of the elements, as had been done by his predecessors, Hansen, in his mode of treatment, regards the elements as constant, and finds what we may term the perturbation of the time. Thus, in place of the time, he uses a function of the time, which he designates by z ; so that if g_0 is the mean anomaly at the epoch, we have the mean anomaly at any time, in the disturbed orbit, given by $g_0 + n_0z$, n_0 being the mean daily motion, and being one of the constants. If there were no perturbations we should have $g_0 + n_0t$, t being the time elapsed since the epoch.

In effecting his solution of the problem, Hansen does not attempt to give general and complete analytical expressions of the series. Instead, he, at the start, converts the coefficients into numbers, and multiplies the series together, two and two, by the methods of trigonometry. Thus, although we find, finally, the perturbations as functions of the time, that is, have the general perturbations, yet, in applying the method to different bodies, we must find the values of all the quantities involved for the particular case under consideration. It would be a great advance if we had at hand complete analytical expressions, of sufficient convergence, as is the case with the larger planets.

Besides the method of multiplying series together by the methods of trigonometry, which Hansen calls "Mechanical Multiplication"—a method he was the first to employ—he also adopts different angles with which to express his arguments. Thus at the outstart he uses the eccentric anomaly for both bodies. When he has computed the powers of the reciprocal of the distance between the disturbed and disturbing bodies, he transforms from eccentric to mean anomaly in case of the disturbing body. And then, when he has expressions for the perturbing function and the forces, he makes another transformation so as to be able to effect the integrations.

The transformations must be done with great care, and require a large measure of time. In addition to the tedium arising from extended operations of this kind (which must be generally done in duplicate to insure accuracy), many of the processes in various stages of the work are not easily grasped, and certainty is often only secured by performing the numerical calculations. Thus, then, although the method has been published for a long time, it has been applied only in a very limited number of cases. Watson, in the Preface to his *Theoretical Astronomy*, says: "The refined and difficult analysis and the laborious calculations involved were such that, even after Hansen's methods were made known, astronomers still adhered to the method of special perturbations by the variation of constants as developed by Lagrange."

Hansen seems himself to have felt the force of these drawbacks on his method, as in a posthumous memoir devoted to the larger planets he abandons his peculiar method of treatment and uses that of Lagrange.

As far as the minor planets are concerned, there is no doubt that Hansen's method, as left by him, is too long and difficult to be practicable.

What we need now is some mode of determining general perturbations that is easily applied and sufficiently short to attract the efforts of a larger number of competent computers. Only in this way can the constantly growing material be utilized. The new method of treatment will now be given as briefly as possible.

If J be the distance between the disturbed and disturbing bodies, Hansen has the equation

$$\left(\frac{a}{J}\right)^n = \left\{ C - q \cos(\varepsilon' - Q) \right\}^{-\frac{n}{2}} \left\{ 1 - q_1(\cos \varepsilon' + Q) \right\}^{-\frac{n}{2}}$$

for finding $\left(\frac{a}{J}\right)$, $\left(\frac{a}{J}\right)^3$, etc.

Instead of the two factors of the second member, I have used a transformation of them given by Hill, and have

$$\left(\frac{a}{J}\right)^n = N^n \left(1 + a^2 - 2a \cos(\varepsilon' - \theta) \right)^{-\frac{n}{2}} \left(1 + b^2 - 2b \cos(\varepsilon' + Q) \right)^{-\frac{n}{2}},$$

where $\left(1 + a^2 - 2a \cos(\varepsilon' - \theta) \right)^{-\frac{n}{2}} = \left[\frac{1}{2} b^{\binom{0}{n}} + b^{\binom{1}{n}} \cos(\varepsilon' - Q) + b^{\binom{2}{n}} \cos 2(\varepsilon' - Q) + \text{etc.} \right]$,

and similarly for $\left(1 + b^2 - 2b \cos(\varepsilon' + Q) \right)^{-\frac{n}{2}}$.

The coefficients of both these factors are the La Place coefficients, and their values have been tabulated. Thus the part of the work relating to the determination of expressions for $\left(\frac{a}{J}\right)$, $\left(\frac{a}{J}\right)^3$, etc., is rendered comparatively short and simple.

In finding J^2 in terms of the radii vectores of the two bodies and of the cosine of the angle between these radii-vectores, the true anomaly of both bodies is introduced. In the analysis we use the equivalent functions of the eccentric anomaly for those of the true anomaly, and then, when making the numerical computations, we cause the eccentric anomaly of the disturbed body to disappear. This is accomplished by dividing the circumference into a certain number of equal parts relative to the mean anomaly, and employing for the eccentric anomaly its numerical values corresponding to the various values of the mean anomaly.

Having found the expressions of $\left(\frac{a}{J}\right)$, $\left(\frac{a}{J}\right)^3$, etc., in series, in which the angles are the mean anomaly of the disturbed and the eccentric anomaly of the disturbing body, the series are changed at once into others in which both angles are mean anomalies. To effect this transformation there is need of functions called the J functions; and a chapter is given in which the expressions for these functions are found in a form convenient for application.

When we have the powers of the reciprocal of the distance between the disturbed and disturbing bodies, we next find the term expressing the effect of the action of the disturbing body on the sun. This is effected without difficulty.

The expressions for the perturbing function and the perturbing forces can now be formed. Instead of using the force involving the true anomaly, the transformation of this, in which the mean anomaly appears instead of the true, has been used. This is the method given by Hansen in his post-humous memoir, in which he has abandoned some of his former notions. The disturbing forces employed are those in the direction of the disturbed radius-vector, in the direction perpendicular to this radius vector, and in the direction perpendicular to the plane of the orbit. The forces in these three directions have been deduced from those in the direction of the three rectangular axes. The force $a \frac{d\Omega}{dg}$ is found at once from the perturbing function by differentiating with respect to the mean anomaly, g .

To find the other two forces symbolized by $a r \frac{d\Omega}{dr}$, and $a^2 \frac{d\Omega}{dz}$, z being the coördinate perpendicular to the plane of the orbit, it is necessary to multiply a number of series together, two and two, by the formulae of plane trigonometry.

Having the values of the forces, we next find the value of a function W obtained by the integration of the expression

$$\frac{dW}{dt} = A. a \frac{d\Omega}{dg} + B. a r \frac{d\Omega}{dr},$$

A and B being two factors easily determined. W being known, the function \bar{W} is next found by simple mechanical processes, and the perturbations of z and of the radius-vector are found at once by the equations

$$n. \delta z = n \int. \bar{W}. dt$$

$$v = -\frac{1}{2} u \int \frac{d\bar{W}}{dt}. dt,$$

γ being a particular form for g .

The symbol δ designates the perturbation of the quantity to which it is prefixed.

The perturbation of the latitude is found by integrating the equation

$$\frac{d. \frac{u}{\cos i}}{n. dt} = C. a^2 \frac{d\Omega}{dz},$$

where C is a factor found in the same manner that A and B were.

To find $n. \delta z$, or the variation of the mean anomaly, two integrations are necessary; in finding the perturbation of the radius-vector, and of the latitude, one integration is needed for each.

The arbitrary constants introduced by these integrations are so determined that the perturbations become zero for the epoch of the elements.

In making an application of his formulæ, Hansen selected the planet Egeria, whose eccentricity is comparatively small, the angle of eccentricity being less than five degrees. In making use of the formulæ given in the method here presented the eccentricity is considerably larger. The convergence of the series is, however, all that can be desired. In computing the perturbations of those of the minor planets whose eccentricities and inclinations are quite large, it may be necessary to divide the circumference into a larger number of parts. In exceptional cases, such as for Pallas, it may be necessary to divide the circumference into thirty-two parts. In case of the applications made of the present method, sixteen divisions have been used: this is the number employed by Hansen for Egeria.

When a larger number than sixteen is used, the calculation of the values of $\left(\frac{a}{j}\right)$, $\left(\frac{a}{j}\right)^3$, etc., is longer; the process is, however, the same in every case.

After the perturbations have been found it is necessary to have them in convenient form for the computation of ephemerides, and there has, hence, been added the method employed for doing this.

The writer has endeavored to present the whole theory in a manner easily comprehended by those having a respectable mathematical education, and in a compass such that the computations can be performed within a reasonably short time. The endeavor throughout has been to use convenient methods, not to devise new ones.

Stated Meeting, March 3, 1893.

Dr. BRINTON in the Chair.

Correspondence was submitted as follows:

Letters accepting membership were received from Prof. George Lincoln Goodale, Cambridge, Mass.; Dr. Charles Schäffer, Philadelphia.

A circular from the Académie de Belgique, Bruxelles, requesting subscriptions to a commemorative edition of the works of Jean-Servais Stas.

The death of Prof. C. Schorlemmer, Manchester, England, January 27, 1892, was announced.

Letters of acknowledgment were received from the Royal Society of Victoria, Melbourne (137); Tokyo Library, Tokyo, Japan (136, 137, 138); Royal Zoological Society, Amsterdam, Netherlands (137, 138); Naturwissenschaftlicher Verein des Reg.-Bezirks, Frankfurt a. O., Prussia (135-138); Oberhessische Gesellschaft für Natur- und Heilkunde, Giessen, Hesse (138); Verein für Thüringische Geschichte und Alterthumskunde, Jena, Saxe-Weimar (138); Verein für Erdkunde, Metz, Lorraine (138); Società Italiana delle Scienze, Rome, Italy (138); Natural History and Philosophical Society, Belfast, Ireland (138); Université Laval, Quebec, Canada (137, 138, and Catalogue i-iv); Editor of *Popular Science Monthly*, New York, N. Y. (139); Wyoming Historical and Geological Society, Wilkesbarre, Pa. (138); Enoch Pratt Free Library, Baltimore, Md. (137, 138, and Catalogue i-iv); Mr. T. L. Patterson, Cumberland, Md. (139); Texas Academy of Science, Austin (137, 138, and Catalogue, i-iv).

Letters of acknowledgment (139) were received from the Laval University, Quebec, Canada; Natural History Society, Sir John W. Dawson, Montreal, Canada; Public Library, Marine Biological Laboratory, Boston, Mass.; Agricultural Experiment Station, Kingston, R. I.; Historical Society, Providence Franklin Society, Providence, R. I.; Mr. George F. Dunning, Farmington, Conn.; Connecticut Historical Society, Hartford,

Conn. ; Prof. W. Henry Green, Princeton, N. J. ; Dr. Charles B. Dudley, Altoona, Pa. ; Dr. Robert H. Alison, Ardmore, Pa. ; Prof. Robert W. Rogers, Carlisle, Pa. ; Prof. Martin H. Boyé, Coopersburg, Pa. ; Hon. Eckley B. Coxe, Drifton, Pa. ; Drs. Traill Green, J. M. Moore, Thomas Conrad Porter, Easton, Pa. ; State Library of Pennsylvania, Harrisburg, Pa. ; Mr. John Fulton, Johnstown, Pa. ; Linnean Society, Lancaster, Pa. ; Wagner Free Institute, Judge Allison, Profs. Charles S. Dolley, H. V. Hilprecht, Albert H. Smyth, W. H. Greene, Messrs. Philip C. Garrett, Edward Hopper, W. W. Jefferis, G. de B. Keim, Joseph D. Potts, L. A. Scott, Richard Wood, Philadelphia ; Prof. John F. Carll, Pleasantville, Pa. ; Rev. F. A. Muhlenberg, Reading, Pa. ; Miss R. C. Longstreth, Sharon Hill, Pa. ; Dr. John Curwen, Warren, Pa. ; Philosophical Society, Hon. Washington Townsend, Mr. Philip P. Sharples, West Chester, Pa. ; Wyoming Historical and Geological Society, Wilkesbarre, Pa. ; Mr. William M. Canby, Wilmington, Del. ; U. S. Naval Institute, Annapolis, Md. ; Maryland Institute, Enoch Pratt Free Library, Maryland Historical Society, Baltimore, Md. ; Smithsonian Institution, Anthropological Society, U. S. Geological Survey, U. S. Coast and Geodetic Survey, Library Surgeon General's Office, Scientific Library U. S. Patent Office, Weather Bureau, Col. Garrick Mallery, Prof. Charles A. Schott, Dr. John S. Billings, Washington, D. C. ; University of Virginia, Leander McCormick Observatory, Prof. J. W. Mallet, University of Virginia, Va. ; N. C. Agricultural Experiment Station, Raleigh ; South Carolina College, Columbia ; Historical Society, Savannah, Ga. ; University of Alabama, University P. O. ; Agricultural Experiment Station, Baton Rouge, La., College Station, Texas ; Academy of Science, Austin, Texas.

Accessions to the Library were reported from the Institut Égyptien, Cairo ; Royal Society of South Australia, Adelaide ; Linnean Society of New South Wales, Sydney ; Royal Geographical Society, St. Petersburg, Russia ; Société Finno-Ougrienne, Helsingfors, Finland ; Société Hollandaise des Sciences, Harlem, Holland ; K. K. Geologische Reichsanstalt,

K. K. Naturhistorische Hofmuseum, Vienna, Austria; Deutsche Seewarte, Hamburg, Germany; K. B. Akademie der Wissenschaften, Munich, Bavaria; Württembergische Commission für Landesgeschichte, Stuttgart; Messrs. Friedländer & Sons, Berlin, Prussia; Society of Antiquaries, Geological Society, London, England; Royal Irish Academy, Dublin; Public Library, Salem, Mass.; American Chemical Society, New York, N. Y.; Bureau of Statistics of New Jersey, Trenton; Pennsylvania Forestry Association, Dr. J. C. Ayer & Co., Dr. Charles A. Oliver, Messrs. Henry Phillips, Jr., Julius F. Sachse, Prof. M. B. Snyder, Philadelphia, Pa.; U. S. Fish Commission, Hydrographic Office, Washington, D. C.; Mr. William Harden, Savannah, Ga.; State Historical Society of Wisconsin, Madison; Agricultural Experiment Stations, Kingston, R. I., Blacksburg, Va., Lexington, Ky., Manhattan, Kans., Fort Collins, Col., Laramie, Wyo.

Pending nominations Nos. 1249, 1250, 1253, 1255 and 1256 were read.

A motion to introduce electric lighting into the building was after discussion withdrawn.

And the Society was adjourned by the Presiding Member.

Stated Meeting, March 17, 1893.

Mr. PRICE in the Chair.

Correspondence was submitted as follows:

A letter from Hon. Robert E. Pattison, Harrisburg, Pa., accepting membership.

A letter from Prof. Robert E. Thompson, Philadelphia, resigning from membership at end of the current year, which was accepted.

The Journal of the United States Artillery School, Fortress Monroe, Va., was placed on the Proceedings exchange list.

Letters of envoy were received from the Meteorological Office, London, Eng.; Royal Irish Academy, Dublin, Ireland; Observatorio Astronómico Nacional, Mexicano, Tacubaya.

Letters of acknowledgment (139) were received from the Theological Seminary, Andover, Mass.; New York Academy of Sciences, Columbia College, New York; New Jersey Historical Society, Newark; Prof. Charles F. Himes, Carlisle, Pa.; Rev. F. A. Muhlenberg, Reading, Pa.; Department of State, Washington, D. C.; Prof. James B. Angell, Ann Arbor, Mich.; Col. William Ludlow, Gen. W. F. Reynolds, Detroit, Mich.; State Library, Lansing, Mich.; Oberlin College, Oberlin, O.; Prof. E. W. Claypole, Akron, O.; University of Cincinnati, Hon. J. D. Cox, Cincinnati Observatory, Cincinnati, O.; Dr. Robert Peter, Lexington, Ky.; Geological Survey of Missouri, Jefferson City; Academy of Sciences, St. Louis, Mo.; Historical Society, Chicago, Ill.; State Historical Society of Wisconsin, Madison; University of California, Prof. Joseph LeConte, Berkeley, Cal.; Lick Observatory, Mount Hamilton, Cal.; Prof. J. C. Branner, Palo Alto, Cal.; Prof. Daniel Kirkwood, Riverside, Cal.; Free Public Library, San Francisco, Cal.; Academy of Natural Sciences, Davenport, Ia.; State University of Iowa, Iowa City; Washburn College, Kansas Academy of Science, Topeka; Agricultural Experiment Stations, Las Cruces, N. M., Lincoln, Neb., Laramie, Wyo.; University of Arizona, Tucson.

Accessions to the Library were reported from the K. Nordeske Oldskrift Selskab, Copenhagen, Denmark; Société Batave de Philosophie Expérimentale, Rotterdam, Holland; Physikalische Gesellschaft, Berlin, Prussia; Verein für Erdkunde, Metz, Lorraine; K. B. Akademie, München, Bavaria; Messrs. Alphonse Pictet, Henri de Saussure, Geneva, Switzerland; Società Africana D'Italia, Naples; Direzione Generale della Statistica, Rome, Italy; Société Languedocienne de Géographie, Montpellier, France; Mr. Manuel de Peralta, Madrid, Spain; Meteorological Office, London, Eng.; Literary and Philosophical Society, Manchester, Eng.; Mr. Robert T. Swan, Boston, Mass.; Free Public Library, New Bedford,

Mass.; Scientific Alliance, New York, N. Y.; Pennsylvania State College, Harrisburg; Mr. Herbert Welsh, Philadelphia; Smithsonian Institution, United States Geographical and Geological Survey of the Rocky Mountains, Adjutant General's Office, Washington, D. C.; Artillery School, Fortress Monroe, Va.; Society of Natural History, Cincinnati, O.; Academy of Science, Tacoma, Washington; Agricultural Experiment Stations, College Park, Md., Morgantown, W. Va., Little Rock, Ark.

The following decease of members was announced:

Hippolyte Taine, Paris, March 5, 1893, æt. 65.

William B. Rogers, Philadelphia, March 15, 1893, æt. 55.

On motion, the President was requested to prepare an obituary notice of Mr. Rogers.

Secretary Barker presented for the Transactions a paper by Prof. Francis C. Phillips entitled, "Researches upon the Chemical Properties of Gases," which was referred to Drs. Barker, Marshall and Smith, a Committee to examine and report upon the same.

A paper by Prof. A. S. Packard, entitled "The Life Histories of Certain Moths of the Families Ceratocampidæ and Hemileucidæ, etc.," was presented by the Secretaries for the Proceedings.

Prof. Snyder presented a paper by W. F. McK. Ritter, "On a New Method of Determining the General Perturbation of the Minor Planets."

Dr. Cope presented a paper by Prof. Dwight, on "Psoas Parvus and Pyramidalis."

Pending nominations Nos. 1249, 1250, 1253, 1255, 1256, were read.

According to notice, the stated business of the evening, the question of withdrawing the Society's collections now on deposit in other institutions, was taken up.

The following minute of the meeting of Council was read :

STATED MEETING, FEBRUARY 10, 1893.

Present : Messrs. Morris, Brinton, Baird, Ingham.

In the absence of the President, on motion, Mr. Baird took the chair.

Minutes of the last meeting of Council were read.

Dr. Brinton, acting Clerk, read the resolution of the Society which was referred to Council for action.

Dr. Morris read the resolution of the Curators, and gave his reasons for holding that the collections of the Society should be retained and exhibited in its present hall.

Mr. Ingham moved that all the collections of the Society be brought back to the hall of the Society ; seconded by Dr. Morris.

Dr. Brinton spoke strenuously in opposition to the motion, and claimed that it was contrary to the spirit of the act incorporating the Society.

Other remarks were made by the members present, Dr. Morris urging the adoption of the motion as in accordance with the spirit of the Society.

The motion being put by the Chair, it was carried.

The Council was adjourned by the Chair at 9.30.

D. G. BRINTON, *Clerk.*

Mr. Prime moved to lay the resolution of Council on the table, but subsequently withdrew the motion in order that the subject might be fully discussed. An animated debate ensued, participated in by Messrs. Houston, Prime, Brinton, Morris, Cope, Jayne, Biddle, Du Bois, Barker, Field and others.

The Presiding Member stated certain reasons that in his opinion rendered the return of the collections at the present time desirable.

The question being put and a call of the yeas and nays demanded, the motion was lost by a vote of 16 yeas to 8 ayes.

And the Society was adjourned by the Presiding Member.

April 7, 1893.]

135

PROCEEDINGS
OF THE
AMERICAN PHILOSOPHICAL SOCIETY
HELD AT PHILADELPHIA FOR PROMOTING USEFUL KNOWLEDGE.

VOL. XXXI.

APRIL, MAY, JUNE, 1893.

No. 141.

Stated Meeting, April 7, 1893.

Mr. SMYTH in the Chair.

Letters of envoy were received from the Nederlandsche Maatschappij ter Bevordering van Nijverheid, Haarlem, Holland; Società Italiana delle Scienze, Naples; Meteorological Office, London, England; Geological Survey Department of Canada, Ottawa; Academy of Science, Tacoma, Washington; Museo de La Plata, Buenos Ayres.

Letters of acknowledgment were received from the Institut Egyptien, Cairo (138); Società Africana d'Italia, Naples (137); Prof. Gaston Maspero, Paris, France (136); Geological Society of America, Rochester, N. Y. (139); Mr. Andrew S. McCreath, Harrisburg, Pa. (139); Department of State, Washington, D. C. (131-136); "Journal of the U. S. Artillery," Fortress Monroe, Va. (137, 138, 139); Society of Natural History, Cincinnati, Ohio (139); Oberlin College, Oberlin, Ohio (137, 138, Catalogue, Parts i-iv); Lick Observatory, Mount Hamilton, Cal. (133); Mr. Everard F. im Thurn, Georgetown, British Guiana (139).

Accessions to the Library were reported from the Institut Egyptien, Cairo; Nederlandsche Maatschappij ter Bevordering van Nijverheid, Haarlem, Holland; Geographische Gesellschaft, Vienna, Austria; Physiologische Gesellschaft, Deutsche Geologische Gesellschaft, Berlin, Prussia; Prof. H. von Helmholtz, Charlottenburg, Prussia; Naturwissenschaftliche Gesellschaft, St. Gall, Switzerland; R. Istituto Lombardo, Milan,

Italy; Società delle Scienze, Naples, Italy; Rassegna delle Scienze Geologiche in Italia, Institut Internationale de Statistique, Rome; R. Accademie delle Scienze, Turin; R. Istituto Veneto, Venice, Italy; Institut de France, Paris; Harleian Society, London, England; Geological Survey of Canada, Ottawa; New England Historic Genealogical Society, American Statistical Association, Boston, Mass.; Connecticut Historical Society, Hartford; Cornell University, Ithaca, N. Y.; American Museum of Natural History, New York; Board of Directors of City Trusts, Engineers' Club, Messrs. Henry Phillips, Jr., Herbert Welsh, Philadelphia; Department of the Interior, U. S. Fish Commission, Washington, D. C.; Academy of Science, St. Louis, Mo.; Lick Observatory, Mount Hamilton, Cal.; Agricultural Experiment Stations, Morgantown, W. Va., Larami, Wyo.; Las Cruces, N. Mex., Tucson, Ariz.; Museo de La Plata, La Plata, Argentine Republic.

Photographs for the Society's Album were received of Dr. F. A. Genth and Prof. F. A. Genth, Jr., Philadelphia.

The death of Isaac Burk (March 30, 1893, æt. 77) was announced.

The Committee on Dr. Phillips' paper on "Gases" reported it worthy of publication in the Transactions of the Society, and was discharged.

Pending nominations Nos. 1249, 1250, 1253, 1255, 1256 were read.

Dr. Ryder presented for the Proceedings a paper entitled "Energy as a Factor in Organic Evolution."

Dr. Cope presented a paper by Thomas G. Gentry on "The Higher Fungi of Philadelphia and its Neighborhood."

Dr. Cope offered the following resolution:

Resolved, That the American Philosophical Society disapproves of the terms of the bill, No. 163, presented by Mr. J. H. Fow to the Legislature of Pennsylvania, entitled "An act to prohibit public exhibitions of mental or physical deformities in certain public places," as opposed to the interests of education and scientific research, and as injurious to the

interests of the class of persons whose exhibition for compensation is forbidden by its terms.

On motion, the Society adopted the resolution and referred the matter to the President, with power to make such representations to the Legislature as he might choose, if in his discretion he saw fit so to do.

And the Society was adjourned by the Presiding Member.

Stated Meeting, April 21, 1893.

President, Mr. FRALEY, in the Chair.

Correspondence was submitted as follows :

A circular relating to the Hodgkins prizes offered by the Smithsonian Institution.

Letters of acknowledgment were received from Mr. Samuel Davenport, Adelaide, Australia (138); Société de Géographie de Finlande, Helsingfors (137, 138); K. Bibliothek, Berlin, Prussia (Transactions, xvii, 1, 2); Société de Géographie, Société Philologique, Marquis de Nadaillac, Profs. E. Levasseur, G. Maspero, Paris, France (139); Comte Hyacinth de Charencey, St. Maurice-les-Charencey, France (139); Prof. Alexander Agassiz, Cambridge, Mass. (139); Mercantile Library, St. Louis, Mo. (Catalogue, Parts i-iv).

Accessions to the Library were reported from the Congrès Internationaux, d'Anthropologie, Archæologie préhistorique et Zoologie, Moscow, Russia; Société de Géographie de Finlande, Helsingfors; Nederlandsche Maatschappij ter bevordering van Nijverheid, Harlem, Holland; K. P. Meteorologisch Institut, K. P. Akademie der Wissenschaften, Berlin, Prussia; Frau Gerhard vom Rath, Leipzig, Saxony; R. Istituto di Studi Superiori, Firenze, Italy; Accademia di Scienze Morale e

Politiche, Naples, Italy; Bath and West and Southern Counties Society, Bath, England; British Association for the Advancement of Science, London, England; Natural History and Philosophical Society, Belfast, Ireland; Harvard University, Mr. A. McF. Davis, Cambridge, Mass.; American Antiquarian Society, Worcester, Mass.; American Oriental Society, New Haven, Conn.; Historical Society, Buffalo, N. Y.; Mr. Lucien H. Smith, Rochester, N. Y.; Free Public Library, Jersey City, N. J.; College of Physicians, American Pharmaceutical Association, Messrs. Finley Acker, Henry Phillips, Jr., Julius Sachse, Philadelphia, Pa.; Office of Chief of Engineers, Department of State, Treasury Department, Bureau of Education, Washington, D. C.; University of Virginia, Charlottesville; California Academy of Sciences, San Francisco; Agricultural Experiment Stations, Storrs, Conn., and State College, Pa.

The following announcements of deaths were made:

Esquiron de Parieu, Paris, died April 9, 1893, *æt.* 79.

Thomas H. Dudley, Camden, N. J., died April 15, 1893, *æt.* 74.

The President was authorized to appoint a suitable person to prepare the usual obituary notice of the late Mr. Dudley. (Mr. William John Potts was subsequently appointed.)

The President announced that Dr. Ruschenberger had been appointed to prepare the obituary notice of the late W. B. Rogers.

Mr. Prime made some remarks on "The Present Revolution taking place in Iron-making in the United States," and was followed by Dr. Morris on the subject.

Dr. Ryder presented a paper "On the Mechanical Genesis of the Fowl's Egg."

Nominations Nos. 1249, 1250, 1253, 1254, 1255, 1256, 1257, 1258 and 1259 were read.

And the Society was adjourned by the President.

The Life Histories of certain Moths of the Families Ceratocampidæ, Hemileucidæ, etc., with Notes on the Armature of the Larvæ.

By *Alpheus S. Packard.*

(Read before the American Philosophical Society, March 17, 1893.)

FAMILY CERATOCAMPIDÆ.

Judging by the larvæ alone, this group is well circumscribed. The most generalized forms are *Dryocampa* and *Anisota*. In these there is no "caudal horn," and the single median dorsal spine on the ninth abdominal segment in *Dryocampa* is about one-third as long as that of *Anisota*, while in *Sphingicampa* the spine is reduced to a minimum. That the larva of *Dryocampa* is the simplest of the family is also shown by the fact that the two rudimentary spines on the third thoracic segment are shorter and less forked, and the other abdominal spines are shorter than in the other genera.

The suranal plate has the shortest spines in *Sphingicampa* and longest in *Anisota*, being of a length intermediate between these two genera in *Dryocampa*, in which, however, they are still long.

Sphingicampa may be regarded as a transitional form connecting *Dryocampa* and *Anisota* with *Eacles* and *Citheronia*.

Eacles in its first larval stage, as compared with that of *Sphingicampa*, differs in the following respects :

The prothoracic segment is armed with spines ; the thoracic spines are in Stage I forked at the end ; the caudal horn is much longer and slenderer, and also forked at the end ; also there is a single median spine on the ninth abdominal segment. *Eacles* is peculiar in the abdominal segments being marked with two black transverse stripes.

Aglia tau, a connecting link between the *Ceratocampidæ* and *Saturniidæ* and the type of a new subfamily, *Aglinae*. In this European Bombycine moth we have surviving, side by side with the generalized *Saturnia*, a most interesting form, which is a *Ceratocampid* in its earlier larval stages, the larva in its last stage and the moth being very near the *Saturnians*, although it does not spin a cocoon, and should be regarded as a *Ceratocampid*. We could not have any clearer demonstration of the origin of one family from another by direct genetic descent.

The transformations of this form, originally figured in Duponchel et Guénée's *Iconographie** (Tome ii), has been more fully elaborated by Mr. Poulton.

Having received, through the kindness of Dr. Heylaerts, a young larva of *Aglia tau* in its third stage, I have been able to compare it with *Eacles*

* Guénée states that after attaining its full size : " Elle se retire à la surface de la terre, entre des mousses et des débris de végétaux qu'elle attache avec de la soie, et elle s'y change en une chrysalide grosse, courte, d'un brun foncé saupoudré de grisâtre, et dont l'anus est terminé par une faisceau de pointes recourbées."

imperialis in its third stage, a thing Mr. Poulton could not do for want of specimens. The resemblance between the two genera at this stage is most striking, although the fully fed larvæ are so different, *Aglia* passing at a single molt (the third and last, this larva only having *four* stages), from one family to another! We know of no parallel case, or at least of one so very striking and conclusive.* Thus the ontogenetic development of this caterpillar epitomizes that of two families, whereas that of most Bombyces is simply usually only an epitome of that of a subdivision of a family, or of a small group of genera.

Aglia tau in its third stage differs from *Eacles imperialis* in its third stage in having a pair of dorsal "horns" on the first and third thoracic segments, where *E. imperialis* has only minute ones on the prothoracic segment, while those on the second thoracic segment are as well developed as those on the third segment; those on the second segment are minute; all the "horns" are forked as in *Eacles*. The dorsal spines on the abdominal are simple and minute, like those on the second thoracic segment. The shape of the head and of the anal legs is much as in *Eacles*, but the suranal plate differs strikingly in being produced into a rather large, spinulated spine, a feature not known to exist in any Ceratocampids.

It should be observed in regard to the large size of the prothoracic horns of *Aglia*, that those of *Citheronia regalis* are quite well developed, being about two-thirds as long as those on the two succeeding segments.

Upon examining the adult of *Aglia*, I find that its head and antennæ are closely similar to those of *Hyperchiria io*, and the Hemileucidæ in general; the antennæ form a close approach to those of *H. io*, as on careful examination with a good lens a second branch of the pectinations of the male antennæ can be perceived; it forms a long, separate branch, but is in the dead and dry specimens very closely appressed to the anterior main pectination. In the venation of both wings *Aglia* shows a most unexpected resemblance to that of *Eacles imperialis*; like that and other Ceratocampidæ and the Hemileucidæ, having five subcostal branches, while in the Saturniidæ there are only four, the first one wanting in the latter family.

Thus the moth belongs with the Ceratocampidæ, while the larva after the last molt loses all its spines and becomes very much like a Saturnian, perhaps of the type of *Telea*, though it is without tubercles or spines, and especially like a smooth form, the larva of *Attacus betes* Walker, figured by Burmeister in his *Atlas of the Lepidoptera of the Argentine Republic*. We therefore suggest that *Aglia tau* should be regarded as the type of a distinct subfamily of Ceratocampidæ, and thus the latter group may be divided into the two subfamilies, Ceratocampinæ and Agliinæ.

*Over twenty years ago, in 1863, when first beginning my studies on the Bombyces, my attention was attracted to the singular changes of *Aglia tau* and I compared the young larva to the full-grown larva of *Citheronia regalis* and pointed out that the latter genus was an "embryonic form and therefore inferior in rank to the Tau moth" (*Amer. Naturalist*, June, 1870, and *Our Common Insects*, 52).

At present both from their larval and their imaginal characters, and in their spinning a cocoon we are disposed to consider the Hemileucidæ as a family closely allied to, though distinct from, the Ceratocampidæ.

On examining the European genus *Endromis*, we are disposed to think that the family Endromidæ is a natural one. It would, however, be a violation of the principles of classification to include *Aglia* with it. The two genera, both as regards their larval and their adult characters, are quite distinct. I find that *Endromis versicolora* has the head, palpi and antennæ and the hairy abdomen very closely like those of our *Hemileuca maia*, but the median vein of both wings divides into four branches, and the subcostal vein of the four wings divides into five branches, as in *H. maia* and the other Hemileucidæ. Judging by the colored figures of the larva in European works, the larva of *Endromis* is smooth, with a small retractile head, oblique bars, and a conical caudal horn. The group Endromidæ is a branch of the Bombycine tree, parallel to but distinct from the Hemileucidæ, and stands above the latter, connecting the group and the Ceratocampidæ and Saturniidæ with the higher families of the Bombyces, in which there are four branches of the median vein, all the families mentioned agreeing with the Notodontidæ in having but three. In its general shape, the small retractile head, the mode of coloration, and the caudal horn, the larva of *Endromis* appears to be remarkably near the Sphingæ. Buckley describes the cocoon as "composed of an open-worked reticulation of coarse black or black-brown silk threads, with round or broad oval interstices, as the fabric is extremely strong, tough and elastic, covered externally with moss and birch leaves firmly adherent" (iii, 65).

It is interesting that in the transformations of *Rhescynthis erythrinæ*, as figured by Burmeister, we have a parallel to the case of *Aglia tau*. The fully grown larva is smooth-bodied and without the four long large thoracic spines, and the caudal horns on the eighth and ninth abdominal segments of the previous stage. The genus appears to belong to the Ceratocampidæ.

Although we are not yet acquainted with the early larval stages of *Endromis*, we do not see why the Sphingidæ may not have sprung from a form like this as much as from *Aglia*, as the shape and markings of the full-grown caterpillar are much nearer a typical Sphinx than those of *Aglia*. Moreover, taxonomically, *Aglia* is by no means so "closely" allied to the Sphingidæ as Mr. Poulton in his able papers would lead us to infer. In its venation *Endromis* is much nearer, and the latter is a more generalized or synthetic form than *Aglia*. From the Ceratocampidæ the families of Saturniidæ and also of Hemileucidæ may have originated, and indeed all the Bombyces, unless we except the Arctians and Lithosidæ, may have evolved before the Sphingidæ appeared. Judging by the characters of the head, the antennæ, thorax, and especially the venation, the Sphingidæ are far removed from the Ceratocampidæ, and their origin from the latter family was at least remote, and there must be some lost, extinct annectant forms which originally connected them.

THE LIFE HISTORY OF DRYOCAMPA RUBICUNDA (Fabr.).

The unfertilized eggs laid in New York, July 15, were kindly sent me by Mr. James Angus, but they did not hatch.

Egg.—Length, 1.4 mm. Oval, a little flattened; the shell yellow, thin, parchment-like, the surface smooth, polished, under a one-half inch objective showing no traces of pits or polygonal areas. The shell is so thin that unfertilized eggs collapse irregularly.

Larva Stage I and II.—The larva was found at Providence by Mr. Bridgman about June 20. The following description is drawn up from his excellent colored figures. He says it molts in a day after hatching, and after the molt the larva is the same as before, except that the general color of the body is a little darker, so that the following description will provisionally apply to both stages.

Length, 5 mm. The head is rather large, rounded, no wider than the body, and deep black. The body is of the same width throughout to the ninth abdominal segment. The prothoracic segment a little wider than the rest of the body. From the second thoracic segment arises a pair of thick large horn-like tubercles, which are about as long as the thickness of the segment bearing them; they are greenish at the base and black beyond; the end is blunt, not tapering at all, giving rise to a hair on each side of the end. All the tubercles on the other segments are in the form of small, simple acute spines of nearly uniform size, those on the prothoracic segment being of the same size as those behind the succeeding segment. There are three rows of spines on each side of the body, and the dorsal ones are no larger than those of the subdorsal and subspiracular series. On the eighth abdominal segment there are two widely separate dorsal spines, and two shorter ones on the ninth segment. The body is pale yellowish green, with a median dorsal and a subdorsal dark-green stripe, also a distinct lateral ridge low down, from which the infraspicular spines arise. The next stage was drawn June 25, "after second molt."

Stage II (?).—Length, 7 mm. The head is now smaller in proportion than before, but still black. *The two horns are now shorter than before in proportion to the body, but otherwise the same; the other spines are slightly stouter. The six lines are now reddish, as is the lower (infraspicular) side of the body.*

Five caterpillars were found feeding side by side on the under side of a red maple leaf, August 12, at Brunswick, Me. They do not start when irritated or use their horns.

Stage III (?).—Length, 8-9 mm. Head rounded, scarcely as wide as the body, very dark chestnut to nearly black. Body cylindrical, not so much flattened as in Anisota. On the first thoracic segment, which is slightly narrower than the second, are two rounded black flattened conical tubercles, not piliferous, and two smaller flatter ones behind. Two larger subtriangular subdorsal black tubercles give rise to three minute short hairs. On the second thoracic segment are two long subdorsal black

spines tapering to the end, which is slightly forked and setiferous, and the spines are minutely spinulated; the two horns are about two-thirds as long as the body is broad. They are represented on the third thoracic segment by two minute conical black tubercles, the homologous ones on the abdominal segments being minute and greenish, tipped with black. Those on the sides of each segment are larger, acutely conical and black. On the eighth abdominal segment are four conical black tubercles, two dorsal and two subdorsal, one on each side. On the ninth segment is a single median conical tubercle, not quite so high as those on the eighth segment, but larger at the base. The subdorsal tubercles on this segment are slightly larger than those on the eighth segment. The suranal plate is subcordate, being excavated in front; behind it is subtriangular, with two black tubercles at the end, which are smaller than those on the side in front of the middle; the suranal plate is greenish, like the prothoracic segment, while the body is tinged with yellowish, with eight faint rather broad whitish longitudinal stripes. The spiracles are black. The thoracic legs are black. The anal legs are greenish, with a blackish patch on the outside near the planta.

In this and the next stage it continues to feed on the under side of the leaf.

Stage IV (?).—(After third molt, June 29) Length, 8 mm. The head is still black, but the two horns are now wholly black, as long as the body is thick, and spinulated. All the other spines are solid and black; the two dorsal spines on the eighth abdominal segment being two or three times larger than the others. The body is now somewhat reddish above as well as beneath, and the longitudinal stripes are reddish. The prothoracic spines are now rudimentary and button-like.

Stage V (?).—(After fourth molt, July 5, Bridgham.) Length, 10 mm. The head is now gamboge yellow, smooth and polished. The two horns as before, being rather slender and spinulated throughout. The body is yellowish green, with faint darker green longitudinal stripes. The tubercles are obsolete, except those on the eighth and ninth abdominal segments, which are black and moderately large.

The following notes were made on caterpillars found in Maine and represent the two last stages of the larva.

Stage V (?).—Length, 20 mm. Head cherry red, about two-thirds as wide as the body, smooth and rounded. Prothoracic tubercles arranged as in the previous stage, but a little larger and more conspicuous; in one example the anterior and posterior dorsal ones are coalesced. The second thoracic horns are black, not much more than half as long as the body is broad. Now the white stripes alternate with the dark-green ones, which are quite distinct, the black tubercles being situated partly on them. The tubercles on the abdomen are longer and sharper than before, and on the base in the middle of the suranal plate is a transverse black plate. The black plate on the ends of the abdominal legs are larger and more conspicuous than before.

Note.—Being now somewhat more exposed when feeding, the head has become of a bright cherry red color, and the body more striped; the armature is longer and sharper, except the two most conspicuous horns of the second thoracic segment.

Final Stage.—Length, 35 mm. The head is considerably narrower than the body, of a uniform pale clay ochre yellow. The prothoracic segment is armed with eight black tubercles arranged in a row across the front edge, the lowest one being placed just above the insertion of the legs, and being acute, while the others are more rounded and button-like. The second thoracic segment bears two dorsal slender black horns, one-half as long as the segment itself is wide, slightly tapering from the base to the end, which is rounded and somewhat truncate. The third thoracic segment with four black conical tubercles like those on the first segment.

The eighth abdominal segment is provided with three black tubercles on each side; the lowest one on this and the seventh segment being larger and sharper than the corresponding ones on segments 1-6. The ninth segment is furnished with a median sharp tubercle, apparently of double origin, as it is slightly forked at the tip; it is about two-thirds smaller than the lateral ones.

The suranal plate is triangular, with the surface flat and rough, ending in two black conical spines, with three on each side in front (in one example two are wanting on one side, and the corresponding ones on the other side are white).

The body is pale pea-green, washed with white on the back between the seven dark-green stripes, one dorsal and three on each side, which are wider and diffuse. The thoracic legs are pale flesh, the abdominal ones greenish. Anal legs large, triangular, rough and granulated, with a few black and white conical spines on the edge above the planta. The fleshy lateral ridge is well developed and washed with a reddish flesh tint on the eighth and ninth segments. The spiracles are jet-black and are conspicuous. The body beneath is as deep, if not deeper green in hue than on the upper side.

LIFE HISTORY OF ANISOTA SENATORIA (Abbot and Smith).

The larvæ hatched August 1 and 2.

Stage I.—Length, 3.5 mm. Head large, round, smooth, wholly black, a little higher than wide; when seen from in front a little wider than the body. Prothoracic segment a little wider than the second thoracic segment, smooth, unarmed, but with a transverse dusky patch extending across it. The second thoracic segment bears a pair of high clavate spines, which are a little longer than the head is wide, and each bearing two terminal bristles of unequal length. The spines are black, being of the same color as the thoracic legs. The body is *wholly greenish yellow*, with long, rather pale, yellowish-brown hairs arising from conical tubercles. The end of the body is a little more yellowish than towards the head.

August 4 the same larvæ had become 5.5 mm. in length. The body was now *green*, with no yellow tints, and the two horns are *black*. The head is scarcely as wide as the body, and the hairs are greener and less conspicuous.

Stage II.—August 10-12. Length, 7-8 mm. *Head, prothoracic segment* above and horns, with the suranal plate and anal legs jet-black. The body is now *dark green with yellowish-green lateral lines and black conical acute warts. A median dorsal dark line; a subdorsal pale yellowish-green line, and below it a lateral wider line of the same hue, separated by a very narrow dark-green line from a broad lateral line which includes the lateral swollen ridge, and a row of conspicuous black tubercles.* Under side of body dark green. The tubercles on the eighth and ninth segments larger than those in front, suranal plate rough, tuberculated, black. Thoracic horns large, long, black, nearly twice as long as the body is wide, and one-third longer than the head is wide. Thoracic legs black; abdominal feet dark green, except the anal pair, which are black.

Stage III.—August 20. Length, 13 mm. The specific characters now appear, so that the larvæ may be easily identified. The head is slightly narrower than the body. Prothoracic plate distinct, black. The thoracic horns are black, one-third longer than the body is thick. The body is dark yellowish green, or rather olive green, *with two narrow yellowish dorsal lines, and a subdorsal and a lateral yellowish line on each side.* The spines are a little longer and sharper than before, otherwise the larva is as in Stage II.

PARTIAL LIFE HISTORY OF ANISOTA VIRGINIENSIS (Drury) (PELLUCIDA A. and S.).

For the larvæ on which the following descriptions are based, I am indebted to Joseph Bridgman, Esq., who sent them from Providence, July 1.

Stage II.—Length, 7 mm. Head large and full, dark amber, wider than the middle of the body. The prothoracic segment is broad, with the front and sides flaring; upper surface dark chestnut. Body chestnut-amber. From the second thoracic segment two very long, sparsely spinulate, black horns arise, which are nearly half as long as the body; they are a little flattened at the tip, ending in two piliferous tubercles. There are on all the other segments six rows of conical acute black tubercles; the eighth segment is armed exactly as the seventh. On the ninth is a single median spine. The tenth segment or suranal plate is paler than the body, and near the edge are six whitish tubercles; and at the end are two long, piliferous tubercles. The spiracles are distinct, being ringed with black. The thoracic and middle abdominal legs are black; the anal legs of the same varnish-colored tint as the suranal plate. The skin of the body is rough, with two lateral ridges, on the upper one of which the spiracles are situated and on the lower a spine. Across each segment behind the

spine is a transverse row of small whitish warts, and other granulations are scattered over the body. The caterpillar is dark, and a somewhat conspicuous object on an oak leaf. It molted about July 14 or 15.

Stage III.—Length, 15 mm. Head light chestnut; slightly narrower than the body, which is much as before in color and appearance. The two horns on the second thoracic segment are now much shorter in proportion, being one-third longer than the segment is wide, or as long as the second and third thoracic and first abdominal segments taken together. The color of the body is the same, but the white granulations, very unequal in size, are more distinct than before. The spiracles are wholly black, and situated between two indistinct broken white parallel lines. The black dorsal spines on the third thoracic and first abdominal segments are smaller than those on the other abdominal segments; those on the eighth and ninth segments are of the same size and larger than those on the other abdominal segments. The suranal plate and anal legs are of the same color as the rest of the body. It molted July 22, having been about seven days in this stage.

Stage IV.—Length, 21 mm. Head as before, as wide as the body in the middle. Some new marks now appear; there is a *broad, dorsal, dark, longitudinal band* composed of a series of square, dark patches, sprinkled over with thickened white granulations, and a *subdorsal band* of the same color, composed of oblong, dark patches, bearing a spine above, and on the lower edge the black spiracle, situated on a white field. The skin is of the color of beeswax. There is a median black forked spine on the ninth abdominal segment. The suranal plate is as before, but the tubercles are long and slender, rounded at the tip, and porcelain white. The two spines at the end of the suranal plate are tipped with black; this plate and the anal legs being paler than the body. The horns on the second thoracic segment are now shorter than before, or as long as the third thoracic and first abdominal segments taken together. The other spines are as before, those on abdominal segments 4-8 being larger than those on the three segments in front.

For comparative descriptions of the final stage of this and of *A. stigma*, by Dr. C. V. Riley, see our *Forest and Shade Tree Insects*, 125, 127.

PARTIAL LIFE HISTORY OF ANISOTA STIGMA (Fabr.).

For this larva, received September 12, I am indebted to Mr. James Angus, of West Farms, N. Y.

Stage IV (?).—Length, 25 mm.; length of second thoracic horns, 10 mm. Head Indian red or dull cherry red. *Prothoracic segment with six large stout forked spines*, where those of *A. virginiensis* are small, almost rudimentary, and they are larger than in the final stage. Also the porcelain white granulations are much larger than in *A. virginiensis*. The horns on the second thoracic segment are movable and much longer than in the last stage, being nearly twice as long in proportion. The spines on all the

succeeding segments are of nearly the same size, being nearly one-half as long as the body is thick; those on the third thoracic segment are unevenly forked and of the same size as those of the sixth and eighth abdominal segments; those on segments 1-5 being a little smaller; those on the third thoracic segment are more regularly bifid than the abdominal ones, which have the smaller fork lower down. The single median spine on the ninth segment is no larger than either of the two on the eighth segment, and armed with white spinules. The suranal plate is rounded with six black and several white spines, the basal black ones the largest. The skin is of a peculiar blackish pitchy color. Spiracles black. The thoracic and abdominal legs are dark pitchy; sides of the anal legs reddish, like the suranal plate. *No subdorsal or lateral pinkish stripe, like those in A. virginiensis.*

Last Stage.—Length, 35 mm.; of the second thoracic dorsal spines, 6.5 mm. The head is of the same color as in the previous stage. The second thoracic spine is about as long as the body is thick, and recurved; the other spines are more curved backwards and downwards than in the previous stage, and their shape is very different, the upper surface being smooth, the spinules being collected on the under side; the usually single large spine being white, and beyond the middle, with smaller abortive spinules on the side; these spinules are larger on the spines of the eighth and ninth segments; suranal plate reddish, its surface rough, with white piliferous granulations; near the base is a large black spine on each side, and two black ones of about the same size at the end forming a fork. Spiracles black. Thoracic and abdominal legs pitchy black; sides of the anal legs reddish. Skin dark, with more numerous white granulations than in the previous stage.

It is quite different and easily distinguished from *A. virginiensis*; compared with this species, the head is of the same size but the color quite different, being *dull cherry or Indian red*, while that of *A. virginiensis* is yellowish amber. All the spines are much longer; those on the back of the second thoracic longer, and those behind two or three times longer; *that on the ninth abdominal certainly three times as long as in A. virginiensis.* The skin is blacker, and thus the granulations are more distinct, besides being larger, while *A. stigma* lacks the subdorsal and lateral pink or flesh-colored bands present in *A. virginiensis*.* The spines on the suranal plate are stouter and longer.

LIFE HISTORY OF SPHINGICAMPA BICOLOR (Harris).

Dr. H. S. Jewett has already (*Pupilio*, ii, 38 and 144) fully described the egg and the larval and pupal stages of this interesting insect, and I have only to add some details omitted by him. My descriptions were drawn up from living specimens, supplemented by examination of the

* Riley says that the body of *A. pellucida* is two-striped and that the spines are shorter than in *A. stigma*.

alcoholic specimens of the different stages. We have, perhaps, a no more interesting and beautiful caterpillar, whether we consider its peculiar appendages, its rich and gorgeous coloration, or its defensive habits, and the most carefully described details will not be superfluous in comparing the different stages with those of its allies, *Citheronia regalis* and *Eacles imperialis*, and the allied South American forms. I am indebted to my friend, Mr. W. N. Tallant, of Columbus, Ohio, for sending me a good supply of eggs from which the second or July brood of larvæ hatched. The food plant is the honey locust (*Gleditschia triucanthos*), though Dr. Jewett adds *Gymnocladus canadensis*, or Kentucky coffee-tree.

Egg.—Flattened oval, disk-like, each end alike. Length, 1.8 mm.; width, 1.5 mm. At first green in color, as the embryo grows, states Jewett, the egg becomes biconcave and changes to yellowish brown, and from thirty-six to forty-eight hours before hatching the head of the larva shows through as a dark brown spot. The egg is about one-half as large as that of *Eacles imperialis*, but of the same shape. The shell under a lens appears smooth, like parchment; under a one-half inch objective the surface is seen to be ornamented with very faint polygonal impressed areas, which are much fainter and less easy to detect than those of the egg of *E. imperialis*. The swollen nucleus or bubble in each polygon is very indistinct.

It is interesting to compare the sculpturing of the shell with that of *E. imperialis* and *Citheronia regalis*, the former being intermediate between *Sphingicampa* and *Citheronia*. In *E. imperialis* the shell is sculptured a little more distinctly with irregular polygonal imprints which are not so closely crowded as in *Citheronia*, and the median raised nucleus or bubble is pale but tolerably distinct. Length, 3 mm.; width, 2.5 mm. In the shell of the egg of *C. regalis* the polygonal impressed cells are easily recognized under the microscope and faintly detected under a strong lens. The cell imprints are much more distinct and more crowded than in the two other genera, while the median nucleus or bubble is more prominent and darker; it varies in diameter in different cells, being from about a third to a half as wide as the cell itself. The walls are quite irregular and not always distinct.

Larva Stage I.—(Described four to five hours after hatching.) Length, 4 mm. The head is large, rounded, smooth, unarmed, except with a few scattered tapering dark hairs; it is blackish chestnut; it is wider than the body and slightly wider than the prothoracic segment, which is broad and flaring in front, as in *Anisota*. It is rather higher than wide, and on the vertex slightly bilobed and is paler in front than behind. The terminal joint of the antenna is slightly bulbous and bears besides the tactile bristle about three olfactory rods.

The body is subcylindrical, a little flattened, but not so much so as in *Anisota*. The prothoracic segment is broad and flattened, smooth and unarmed, except with about a dozen dark small hairs. On each side of the second and third thoracic segments is a subdorsal pair of remarka-

ble movable spines, nearly two-thirds as long as the body, which open and close together like great arms, spreading apart, or directed forwards and outwards more or less constantly while walking, the creature at this age being rather active; they are evidently at this period defensive organs. They are stout, thick at the base, those of each pair close together at their base; they slowly taper towards the end, and are armed with 12-14 short, thick, blunt, dark spines; at the end of the spine is a remarkable bulbous expansion somewhat chestnut-shaped, being a little flattened and subtriangular, broad at the end, from each side of which arises a small slender tubercle bearing a blunt, stout spine about a third longer than the tubercle. The appendages themselves are dark chestnut, pale amber at base and on the outer third, but the bulbous tip is dark reddish black. Those of the third thoracic segment are very slightly shorter than the pair in front and in each pair the outer spine is the shorter. These horn-like appendages are flexible, especially near the end, and are sometimes bent over and around so as to form a decided bow or curve, or even a nearly complete circle. Compared with those of *Citheronia regalis*, which they most nearly resemble, those of *Eacles imperialis* being forked at the end, the bulbous tips are a little longer, but still of the same general shape and size.

Along the abdominal segments are six rows of very long and slender conical tubercles, giving rise each to a single black seta, which is about a third longer than the tubercle; there are thus six piliferous tubercles on each segment (1-7), the lowest of which, one on each side, is situated just above the base of the legs, and has a double base, sending off posteriorly at nearly right angles to the main tubercle a small lateral one, which emits a black bristle.

On the eighth segment is a very large, stout, acute, bright-red horn, which is borne either erect or directed a little forward; it ends in two long, slender tubercles, each bearing a bristle about as long as the tubercle, and along the trunk are several large spinose tubercles, each ending in a black bristle. The dorsal median tubercle on the ninth segment is broader than long, being transverse, and bears two bristles. The suranal plate is rather narrow, much narrower than long, and ending in two long slender tubercles, each bearing a dark bristle, besides four other bristles. The anal legs are provided with a dark patch on the side and bear long bristles, while there are three black bristles on the base of each middle abdominal leg. There are sixteen (possibly eighteen) crochets on each of the abdominal legs. The body in general is pale green, with a slight yellowish tinge.

There is a median linear dorsal line along the body, and on each side are four narrow dark lines on a green ground, the two middle lines being diffuse, and enclosing a dark band and bearing a row of bristles. The freshly hatched larva spins a silk thread, which after a while is annoying to the observer from its being in the way and adhering to the leaves of its food plants.

The larva, July 17, just before moulting.—Length, 7 mm. The head is now small, black, one-half as wide as the body, which is filled out from five days' feeding. The longest thoracic spines are scarcely one-third as long as the body, and all are pale reddish amber at base and on the outer third, the terminal knobs being black-brown. The caudal horn is also pale reddish amber at base. There is now a definite, broad, white, lateral stripe along the abdominal segments (not appearing in the thoracic), which is bordered above by a dark, thread-like, brownish, spiracular line, enclosing the spiracles which are minute and difficult to detect. Above the spiracular line is a linear distinct white line, and above this is the pale-green subdorsal stripe, diffusely edged on each side with a darker tint. There is a median, small, rounded, amber-colored, dorsal tubercle on the ninth segment, which is double, bearing two bristles. The end of the suranal plate is reddish amber, bifurcate and bearing black bristles. There is a dark patch on the outside of the anal legs.

Stage II.—Moulted July 18 and 19. Length, 10 mm. The head is now high, *slightly angular on the sides*; black-brown with a *light-brown or greenish lateral stripe* on each side, diverging from the light-green vertex to the antennæ, the two stripes varying from pale brown to green. The great spines (both thoracic and caudal) are of about the same proportions and colors as in Stage I, except that the eight thoracic spines, which are still no shorter in proportion to the body, are not so much swollen at the end, the bulb being shorter and broader, and the spines larger, making a more decided fork, and thus resembling those of *Eacles imperialis*. On each of the abdominal segments there is a posterior, transverse row of *six dorsal, distinct, piliferous, conical warts*, there being only two minute ones in Stage I. The anterior series of piliferous tubercles on each segment are now rather large, conical, *the two dorsal ones large and stout*, twice as large as the subdorsal and lateral ones, and all being lemon-yellow (less greenish than before) bearing a terminal black spine, and with a second piliferous tubercle growing out from the side.

The dorsal lines have almost disappeared, there being a subdorsal, pale, almost whitish line, besides a faint, narrow, dorsal, greenish line. *The lateral ridge is now prominent, and bright lemon-yellow*, forming a distinct broken line, bearing in the middle of each segment a very slender, blackish, piliferous wart. A dark reddish purple, narrow, spiracular line; between this and the yellow line is a white stripe and another narrower one above it, while still above is another reddish purple line. Otherwise the markings are the same, the suranal plate, however, is edged with lemon-yellow, being the continuation of the lateral yellow band.

Thoracic and abdominal legs "green tipped with brown" (Jewett).

In this stage upon touching or teasing the larva the thoracic spines spring out, at the same time the head together with the thoracic region jerk violently, as if to beat off an intruder. Also when two caterpillars meet they evidently attack each other, butting and striking with their horns, like two hostile goats, deer or cattle. It seemed evident, after

repeated observations, that the great thoracic spines are of real defensive use.

An examination of Fig. 2 will illustrate better than a prolix verbal description the appearance of the spines in Stages I and II of this species. They are all drawn with the camera, and it is to be observed that the "horns" are more like those of *Citheronia regalis* than *Eacles imperialis*. *a*, one of the horns on the second thoracic segment; *a'*, the extremity enlarged, showing the circular corrugations; *a''*, the same more magnified; *a'''*, a terminal spine enlarged, showing its mode of insertion; it contains a central mass of minute globules; *b*, the first abdominal segment enlarged to show the position of the dorsal, subdorsal, supra-spiracular and spiracular stripes, the latter enclosing the spiracle; also the position of the four spines, one dorsal, one subdorsal and two infraspiracular; the spines are all minutely barbed; *c*, a dorsal spine, bearing a spinule at its base; *d*, "caudal horn" or medio-dorsal spine on eighth abdominal segment; *ix*, that on the ninth segment; it is small, conical and forked at the end, each fork bearing a long seta. All the foregoing in Stage I. *f*, a "horn" from the second thoracic segment, Stage II; the two terminal spines have entirely changed in shape, being larger and longer, and bearing a tapering fine bristle; a third smaller conical tubercle has appeared near the base of one of the forks. The spinules on the trunk now bear a bristle; *e*, "caudal horn" of Stage II; now large and high, deeply forked at the end; the spines or tubercles on the trunk at the horn now bear each a slender bristle.

Stage III.—Molted July 26, 27. Length, 13-15 mm. The head is now high, the face subtriangular, not black as before, with a green lateral stripe, but *pea-green with a yellow stripe on each side*, shaded more or less with black between the yellow V; and on the outside, in one example, the black is reduced to a diffuse patch inside, while in another larva it is outside of the yellow V. The head is now nearly as wide as the body.

The eight horns are still nearly half as long as the whole body and are now paler than before, being reddish chestnut and yellow at base, with black spinules and blackish at the tips, which are now not bulbous, only irregularly forked. The spines along the body are larger and stouter than before; the tubercles at base are deeper yellow than before, tipped with black, while the high, conical or (sometimes) rounded granulations are snow-white. The lateral yellow stripe along the body is more distinct than before; it is bordered above with pure white, and above this is the linear dark purple spiracular line, shaded above more distinctly than in the preceding stage with deep blue-green or verdigris green; the caudal horn as before being pink, with white spines bearing black bristles. The larva also differs from that of Stage II in the suranal plate, which is more deeply forked, *the forks being thicker, larger and with several tubercles*; the sides of the plate are heavily spined and on the surface are about six central, small, conical spines. Now the dorsal abdominal

spines are *distinctly ivory-white on the outer side from the base up to the dark tip*. The spiracles are much larger than before, distinctly interrupting the dark purple spiracular line which is paler than before.

Stage IV.—Molt not seen, but it probably occurred August 1 or 2. Length, 25–28 mm. The head is, as before, with two yellow stripes, one on each side, and bordered more or less on each side, especially in front, with black. *The four pairs of thoracic horns are now but little longer than the body is thick* and are reddish flesh-color, dark at the slender forked tips, and yellowish green at the base.* *The "caudal horn" is now considerably shorter in proportion than before, being about two-thirds as long as the body is thick*, and is of the same peculiar deep flesh-red as the thoracic horns. The sharp, stout, spine-like tubercles on the fourth and sixth abdominal segments are slightly over twice as large and thick as the other dorsal tubercles which are as in the previous stage, and bear a vertical of from three to five short blunt spinules; *they are now silvery white on the outside* (Jewett says burnished silver). The lateral yellow, carmine, white and blue bands are much as before. The increase in size of this stage over the preceding one is noticeable.

In his account of this stage Jewett states that the head is "green, bilobed, minutely pubescent," also that the thoracic horns had lost their knobs at their extremities; but this appears to take place at the time of the second molt.

In a larva 20 mm. long, and probably of this stage, the lateral band is tricolored, marked below with straw-yellow, the yellow enclosing the base of the black spines. Jewett says: "The legs of some larvæ are green and of others brown. Prolegs of some green and in others green tipped with brown. In some larvæ the stigmatal space has numerous small, black tubercles on each segment; in others there are no black tubercles."

The following description of another larva, drawn up October 10, and probably in the fourth stage, may be useful.

Stage IV (?).—Length, 24 mm. Body rather thick. Head remarkably Sphinx or Smerinthus-like, as wide as the body, flattened in front, broad below about the mouth, but narrowing towards the vertex, as in Sphinx; the skin rough; with two lateral, rather broad, yellow lines, which arise from the base of the antennæ and converging nearly meet on the vertex; across the upper division of the clypeus is a blackish band which adjoins a black blotch on each side, and which touches the yellow line. Labrum pale yellowish, blackish in the middle; eye-patch and mandibles black.

Prothoracic segments very slightly wider than the rest of the body in front; the front edge flaring and rising up somewhat collar-like; this edge armed with a single row of white tubercles, about ten on each side of the segment, those above nearly adjoining at base and tinged with

* Jewett says the spines are "brown in some larvæ and green in others."

yellow; those on the sides below pure snow-white; behind the front edge are four small but distinct white warts, two in the middle.

The second and third thoracic segments each with two widely separated pairs of horns, not quite so thick as the caudal horn, each about two-thirds as long as the segments bearing them are wide; they are slightly recurved and scattered over them are conical white tubercles which are irregular and blunt at the end; they are yellowish at base, near the middle becoming dark pink and at tip reddish black-brown. On the front edge of the second thoracic segment between the horns is a row of three conical sharp tubercles, with a similar and some minute ones on each side, while on the third segment are two similar white warts.

Across the dorsal side of the abdominal segments 1-7 are two rows of white, sharp, conical tubercles; two of those on the front edge of each segment being longer and sharper than the others and directed backwards. On these same segments (1-7) is a third set of curious tubercles, mostly large conical and black internally, but on the outside shining opalescent pearl or silvery white, and resplendent, glittering brightly by lamplight. Of these curious spines those on the first abdominal segment are smallest, and those on segments 4-6 are largest, being about one-third as long as the caudal horn; the pair on segment 6 being the largest. The "caudal horn" on the eighth segment is large, with a few white tubercles, those at the end of the horn being reddish; the tip is slightly forked, there being two minute tubercles; all those on the sides of the horn bear a short fine hair. In the middle of the ninth abdominal segment and in a position homologous with the caudal horn, is a minute, short, median, white wart, which is reddish at the base. The suranal plate and hind legs are very large, the surface rough and heavily warted, especially on the edges; the lower edge of the anal legs and suranal plate are interrupted with black. The eighth and ninth segments and base of the suranal plate are a little wider than the middle abdominal segments. The suranal plate is a little longer than wide, subacutely triangular, the tip forked and ending in two rather large tubercles, which are greenish at the end, blackish at base, with a little transverse median black stripe in front.

The stigmata are deep flesh colored, with a slit in the middle, whitish, especially at the end. The stigmatal line along the side of abdominal segments 1-8 is whitish, edged above with purple, and still above washed irregularly with livid greenish blue, while from the eighth segment to the tip of the suranal plate the line is straw-yellow. Below, near the base of the feet, is a lateral row of sharp black spines; there are several on the sides of the thoracic segments and one rather large one under each spiracle, with smaller sharp ones below. The thoracic legs are black; the middle abdominal legs large, greenish, with two or three alternating rows of sharp black spines near the base, and also with fine white tubercles like those on the rest of the body. Along the middle of the under side of the body the skin is immaculate green.

Stage V and last.—Length, 35–38 mm. (Jewett says from two to two and a half inches when fully grown). The head is now not angular but rounded, though slightly narrowing and produced above; dark pea-green, considerably darker than the body; with a broad yellow band beginning on the antennæ and fading out on the vertex. The ocelli are black; the mandibles black; the anterior lobes of the labrum brown, including the palpi. The head is about two-thirds as wide as the body, the surface covered with fine minute granulations arranged in groups (only seen under a strong Tolles lens).

The body is thick; the prothoracic segment short, and not so wide as the second thoracic segment. It is unarmed, its front edge with a transverse series of white bead-like warts set close together. Behind, the body is thick, being of the same thickness as far as the eighth abdominal segment. Second and third thoracic segments each with two pairs of very large spines which are about two-thirds as long as the body is thick; the outer one of each pair is slightly shorter and slenderer than the inner, but those of both pairs are alike in size; they are roseate, pale coral-red and not so near in tint to the spines of the food-plant as in the young; when the caterpillar is at rest they are held close together in a recurved position and in the grown-up larva when touched they are not moved or the body jerked in response to such stimulus. They are adorned with white blunt spines, which are often tipped with black.

“The ‘silver horns’ on the fifth to the tenth segments are now one-sixteenth to one-eighth of an inch long, bright pink inside and burnished silver externally. The number of these ‘silver horns’ varies in different larvæ, some having them only on the seventh and ninth segments; others have them on the fifth, seventh and ninth segments; still others have them on the fifth, seventh, ninth and tenth segments” (*Papilio*, ii, 49). “I have now to add that this year I reared three larvæ having these silver horns on every segment except the twelfth; still the imagines from these three larvæ did not differ from the ordinary form” (Jewett, *Papilio*, ii, 144).

The horn on the eighth abdominal segment is now only about one-fourth shorter and thicker than the thoracic spines, and is of the same color and structure, the spinules being conical, rounded, blunt, white, and bearing a fine bristle.

On abdominal segments 1–7 are two dorsal rows of acutely conical spines, which are recurved and directed backwards. Those on the fourth and sixth segments are twice or thrice as large as those on the other segments (1–3 and 4 and 7) and provided with three or four blunt spinules; the spines themselves are roseate on the inner side, and externally brilliantly painted with a pearly silvery white, giving off all the colors of the rainbow during the movements of the animal. The corresponding spines on the other segments are painted in the same fashion though less brilliantly.

On the side of the body from the third thoracic horns to the eighth ab-

dominal spiracle is a bicolored stripe; it is pure marble-white below, and above rosy purple, and is interrupted by the wax-colored spiracles, which extend above the upper limits of the reddish line. The suranal plate is very large and long, deeply divided at the end, the two forks being, like the surface, coarsely granulated with stout short conical spines; the plate is green, with the edge straw-yellow. There is a minute median spine on the ninth abdominal segment. Each abdominal segment with two dorsal transverse rows of white, bead-like, coarse granulations. Below the bicolored lateral stripe is a black, double, conical spine on each segment, and underneath on abdominal segments 1, 2, 7 and 8 is a group of unequal, smaller, black, sharp spines. The body beneath is granulated with white, and also on the sides, as well as above.

The thoracic legs are black, partly greenish beneath; the abdominal legs, including the anal pair, are greenish, with a group of singular black piliferous spines, while some of the spines are tipped with white.

The general color of the body is of nearly the same hue as the under side of the leaves of the honey-locust, and thus colored it is partly assimilated and protected by its color, while the horns are in general like the spines of its food plants. On the other hand the gleaming silvery spines certainly render the creature conspicuous, as well as the lateral parti-colored band.

It would appear probable that the formidable spines of the grown-up caterpillar save it not infrequently from being swallowed by birds; though the horns are probably of greater use in the earlier stages when they are much longer and much more movable, in frightening away ichneumonids and Tachinæ. For example, even when 20 mm. in length, a larva was seen when teased to spread apart its great arm-like horns, while the full-fed ones did not notice such stimulus.

SUMMARY OF THE SALIENT FEATURES IN THE ONTOGENY OF SPHINGICAMPA BICOLOR.

A. Congenital Characters of the Larva; all appearing in Stage I.

1. The two pairs of enormous spines of second and third thoracic segments one-half as long as the body, and ending in a two-spined, large, flattened, dark bulb; freely movable and plainly defensive in function.

2. The large, reddish, spiny "caudal horn," on the eighth uromere, ending in two bristles.

3. The double piliferous tubercle on the ninth uromere; becoming obsolete in Stages IV and V.

4. The abdominal region is longitudinally striped with dark and whitish bands, but there are no transverse marks in Stage I or in later stages.

B. Evolution of Later Adaptational Characters.

1. The head slightly angular, face subtriangular, with a light brown or greenish lateral stripe (Stages II-V).

2. Appearance of a transverse row of dorsal granulations on the hinder end of each segment in Stage II, persisting through larval life.

3. The eight thoracic spines lose their bulbous tips, and become simply slightly forked in Stage III, and later.

4. The two dorsal spines of uromeres 1-7 are in Stage II larger than the others; in Stage III they become ivory-white externally, and in Stage IV larger and silvery white on the outside.

5. In the last two stages the eight thoracic spines become very much shorter in proportion to the size of the body and become less movable; as they decline in size and functional importance, the metallic, silvery, dorsal spines on the abdominal segments become conspicuous and apparently useful to the larva.

One larva, 36-37 mm. in length, ceased feeding August 7, and began to pupate, but I did not carry any into the pupa stage.

What Dr. Jewett means by saying that "the larvæ change only in size during the last moult," we do not understand, as the increase, so far as we have noticed, is gradual from Stage I to V, as in other larvæ. The brood which Dr. Jewett raised in Ohio, "began to quit feeding on the 20th of June, entering the ground within a few hours after ceasing to eat. Then they pupated within an oval cell lined with a thin cocoon of silk, the first casting its skin on the 24th. The pupa is at first bright green, but changes to jet black in a few hours."

"Imagines began to appear on July 3, and had nearly all emerged by July 10. The insect is three-brooded here, hibernating in pupa. Although the large majority of each brood follows the cycle of development as described, yet a few of each brood are much slower in making their changes. Thus a few of the brood did not complete their growth till the end of July, and three pupæ, formed June 26, are still alive (February 28), having hibernated. Other pupæ of the same brood disclosed their imagines at various periods during July and August. This accounts for the fact that larvæ in all stages of development may be found at any time throughout the summer till frost kills their food-plants" (Jewett).

Remarks on Sphingicampa bicolor.—This is the most Sphinx-like of any Ceratocampid or other Bombycid I know, resembling sphingid caterpillars in the following characters:

1. The shape of the head and its markings.
2. The four thoracic horns (like those of *Ceratomia*) perhaps a case of reversion in the latter.
3. The caudal horn.
4. The large, square, heavy anal legs.
5. The skin granulated with small white tubercles.

One can, when we take into account the larvæ alone, well imagine that the Sphinges are, as claimed by Mr. E. B. Poulton, descended from the Ceratocampidæ, though these may be only adaptative characters, and not applicable to the imagines, which differ in venation, in the tongue, and in the proportions of the head pieces.

The horns in *Sphingicampa* are not held spread out as in *C. regalis*, but those of each pair are constantly held close to each other. The horns and the six silvery, opalescent, shining tubercles probably become terrifying by the movements of the larva. The latter are turned on and throw their light out suddenly like flashes and may thus have a deterrent effect on their enemies.

LIFE HISTORY OF *EACLES IMPERIALIS* (DRURY).

The eggs were received from Mr. James Angus, and the larvæ hatched from them reared in Maine, so that their development, owing to the cooler climate, may have been less rapid than in New York, where the eggs were laid.

Egg.—Length, 3 mm.; breadth, 2.5 mm.; thickness, 2 mm. Flattened elliptical, each end alike, white, with an equatorial, smooth, distinct ridge. The shell is white, the surface under a high-power triplet is seen to be finely pitted, the pits being shallow and not closely crowded. Under a half-inch objective the pits are seen to be shallow, and not often with a definite raised edge; often there is a boss or bead in the centre. Arising from the spaces between the bosses are slender, short, very minute hairs, originating from a swollen base. Under a one-fifth objective, as well as a one-half and a triplet, I cannot distinguish between the microscopic structure and markings of *imperialis* and *regalis*.

The Freshly Hatched Larvæ.—Some were seen drawing themselves out of the shell June 30, at noon. Length in a few minutes after hatching 7-8 mm.; width of head, 1.5 mm. The tubercles and spines become erect before the larva entirely deserts the shell.

The head is large and full, smooth, shining, nearly twice as wide as the body behind the middle, but the prothoracic segment is much wider than the body; the prothoracic segment is above of the same color and the surface shines like the head. The body is pale chestnut, with a slight pinkish tint. All the spines are, before it entirely leaves the egg, shining jet-black; the five longest ones (four thoracic and one median abdominal) bearing white hairs, the end hairs on all the shorter ones being black. The thoracic segments are without transverse dark stripes, but on each of abdominal segments 1-7 there are three transverse, distinct, conspicuous, black dorsal stripes; the first one in front of the spines is broken, and wanting on the first abdominal segment; but the two behind are unbroken and extend a little below the position of the spiracles. The spiracles are hard to detect as they are situated on an oblong or fourth transverse black band between the two lateral spiracles. The eighth and two last segments are not banded. The large anal legs are edged with black behind. The thoracic legs are black.

There are four spines on each side of the prothoracic segment, all of very unequal length; the lowest one minute and bifid; the one in front of the spiracle stumpy and ending in five slender, papilliform, piliferous

tubercles. The subdorsal one is much longer and forked, while the two dorsal ones are very long and slender, about as long as the head is broad and deeply forked, each fork bearing a bristle. *The two dorsal tubercles on the second and third thoracic segments are enormously long and very slender, being about half as long as the body. They are deeply forked, each fork long and slender, and bearing a long bristle. The tubercles on abdominal segments 1-7 are small and short, of nearly equal length, simple except those of the infraspicular row, which are deeply forked. The single median tubercle on the eighth abdominal segment is remarkably long and slender, about two-thirds as long as the thoracic ones. There is also a single median forked tubercle on the ninth segment, not half as long, however, as the one directly in front. The suranal plate bears at the end two long five-branched piliferous tubercles.* All the tubercles are of nearly the same color as the body, the five longest ones, however, a little brownish near and at the end.

The four middle pairs of abdominal legs are shining black externally on the outer half; otherwise they are concolorous with the body.

The following description is drawn up from some larvæ at the end of Stage I, living October 9 or 10 and reared by Mr. Bridgman: they were about 7 mm. in length and had been kept for a number of days and died before molting. The head is large, full and rounded, smooth and shining honey-yellow; nearly twice as wide as the body (actual width, 1.5 mm.), rounded above on the apex; the eyes and mouth-parts black; labrum whitish. The body is ochreous. The prothoracic segment is very broad and flaring in front, nearly as wide as the head, bearing ten black spines, of which the two dorsal ones are about as long as the body is thick, each bearing three or four small, short tubercles, and ending in a long fork, each branch bearing a long seta which is white at the base. The subdorsal spines are a little less than half as long and large as the dorsal ones. The dorsal second and third thoracic horns are very long and large, being nearly twice as long as the middle of the body is thick; the stalks are knotted (not tuberculated), and deeply forked at the end; each fork thick and ending in a seta. Those on the third segment are slightly shorter with a smaller fork than the two on the second thoracic segment. Each abdominal segment is provided with six black spines; the two dorsal ones about half as long as the body is thick, with two or three minute warts; they are forked at the end, the lower fork small, about as long as the spine is thick, and not bearing a seta, while the other fork or tine is directed obliquely upward.

The spines of the next row outside (subdorsal) are small and simple, while the lateral row near the base of the legs is composed of branched spines nearly as large as the dorsal ones, and with each branch ending in a long seta. The caudal spine on the eighth abdominal segment is nearly as large as those on the second and third thoracic segments, but with a smaller fork, each ending in a seta. There is a median dorsal spine on the ninth segment, about one-half as long and large as that on the eighth,

with three branches, the two terminal forming an uneven fork. There is no distinct suranal plate, only a subtriangular flattened area bearing along the edge six black spines of very unequal size. Around abdominal segments 1-7 is a double, black band, and the lateral and subdorsal spines on these segments are connected by a black band, also enclosing the spiracles; these short bands alternating with long bands passing over the body. The thoracic legs are black; the abdominal legs dull ochreous, with a large, black patch covering the outside. The anal legs are rather large and square, ochreous, the hinder edge pitchy red.

It may be observed that the median dorsal spines on the eighth and ninth abdominal segments are forked like those of *H. io*; this and *H. maia* being apparently earlier forms.

Stage II.—July 10, 11. Length, 13-15 mm. The head is as wide as the thoracic segments (exact width, 2 mm.); it is chestnut brown, a little darker on the sides above the eyes and on the clypeal region. The spines on the prothoracic segment are much as before, *but stouter and shorter*. The dorsal spines on the second and third thoracic segments are much as before *but not quite so deeply forked*; they are dusky amber wax at the base, and black beyond; they are irregularly spinose from base to tip; each fork bears a white hair. *All the other spines are black*. The "caudal horn" on eighth abdominal segment is stouter at base, the trunk with larger, longer and more numerous spinules, which end in a bristle which is not present in Stage I; it is still evenly forked.

The subdorsal spines are now much shorter than before and simple and conical; while the lateral series, instead of being nearly as long as the dorsal ones and deeply forked, are short and stout, ending in three short, stout, piliferous spines.

The body is now dull chestnut, with dusky discolorations, but *without the decided black bands and spots of Stage I*, the body being decidedly darker. The black spiracles are surrounded by a diffuse black ring. The thoracic legs are black; the middle abdominal legs jet-black outside, on a chitinized portion; the anal legs are of the color of beeswax, with a jet-black spot or wart at the tip, and a dusky patch on the sides; these black plates are *larger and longer than in Stage I*.

The descriptions of Stages III and IV were drawn up from a series reared at my request by the late Mr. S. Lowell Elliott and preserved in alcohol; the colors are described from a set of drawings by Mr. Bridgman. Mr. Elliott observed five stages.

Stage III.—(Preserved the third day after the second molt.) Length, 30 mm.; width of the head, 3 mm. The head is narrow, about one-half as wide as the second and third thoracic segments; chestnut brown with two pale, longitudinal bands in front, each band ending at the base of the pale antennæ. *The two dorsal spines on the prothoracic segment are much shorter* than in Stage II, with much stouter lateral spinules, and with shorter forks at the tip, and the spines on the trunk are shorter. The two second thoracic dorsal spines are a little stouter than before, but are

nearly as in Stage II, and are spinulated in the same way; they are 4.5 mm. in length; they are pale on the basal half and dark brown on the distal half; the corresponding spines on the third thoracic segment are a little shorter. *The dorsal and lateral spines on abdominal segments 1-7 are much smaller in proportion than in Stage II, the dorsal spine being still unevenly forked. The "caudal horn" on the eighth segment is now 3 mm. in length, and is still regularly forked as before. The corresponding single median spine on the ninth segment is minute and much smaller than before. The two larger spines on the suranal plate are smaller than before, each bearing four spines, and behind these on the edge of the plate are four minute conical spines; the plate is regularly rounded behind; it is dark brown in the middle, with paler rounded granulations. On the side of the anal legs is a similarly ornamented distinct, narrow, triangular field not developed in Stage II. The middle abdominal legs are tipped with black as before. The body is more hairy than before.*

The general hue of the body is at first pale yellowish brown (raw sienna), with a large pale area around the dark spiracles. There are no distinct markings. Towards the end of the stage the body in those feeding on white pine becomes decidedly reddish, and in fact the color varies from violet through all shades of golden brown and orange purple to black. The horns are rosy-red at base; there is a broad, pale, diffuse, subdorsal band on each side and the dark spiracles are rendered very conspicuous by the broad yellowish ring around them.

Fig. 3.—Armature of *Eacles imperialis*. Stage I. *a*, a dorsal prothoracic spine; *b*, a subdorsal prothoracic spine; *c*, a dorsal spine of the second thoracic segment; *d*, a dorsal spine of the third thoracic segment; *e*, the first abdominal segment, side view, showing the anterior and posterior black band, and the position of the dorsal, subdorsal and infraspicular spines with the spiracle; *f*, the suranal plate, in part, bearing the anterior spine, ending in four setiferous tubercles and the two smaller, simple spines at the end of one side of the plate; *g*, the "caudal horn" or medio-dorsal forked spine of the eighth uromere, seen partly from the side; *g'*, end of the same, seen from in front, showing the two forks; *h*, one of the dorsal spines on the ninth uromere; all drawn with the camera to the same scale.

Fig. 4.—Armature of *Eacles imperialis*. Stage II. *a*, end of one of the dorsal prothoracic "horns;" *b*, one of the dorsal second thoracic "horns;" *c*, the "caudal horn," or medio-dorsal spine on the eighth uromere. Stage III. *d*, one of the second thoracic "horns;" *e*, the "caudal horn" or medio-dorsal spine of the eighth uromere. All drawn with the camera to the same scale.

Stage IV.—(Four days after the third molt.) Length, 40 mm.; width of the head, 4.5 mm. The characters of the full-grown larva are now nearly assumed. The head is, in one specimen, twice banded with pale yellowish in front, in another the bands are nearly obsolete and the head almost entirely dark chestnut. The two dorsal prothoracic tubercles are now

very short, not so high as broad, and end in a group of rounded conical spinules; those on the side of the same segment having the same general shape. *The second and third thoracic segments, with the dorsal horns, now much as in the full-grown larva, though a little slenderer; length, 5 mm.; they are more curved than before and directed backwards and provided with numerous dense conical tubercles; they are pale yellowish at base, and rosy on the distal half, becoming black at the tip, which is still regularly forked; the two pairs are of the same shape and length. The abdominal dorsal spines are much stouter and shorter in proportion than in Stage III. The subdorsal (supraspiracular) spines are simple, conical; the lateral (infraspinal) spines are very short, and composed of four spines. The "caudal spine" (single median dorsal spines on eighth abdominal segment) is now much stouter, more conical than before; 2.5 mm. in length and furnished with crowded spines, but still ending in a regular fork. The suranal plate is as before, but the spines are shorter, and the exterior of the anal legs are ornamented as before.*

The hairs are now long and abundant, some of the dorsal ones longer than the body is thick. The spiracles are very conspicuous, each being surrounded by a broad green ring, outside of which is a yellowish ring, which is margined with yellowish brown. The body is dark umber-brown; the reddish spines and the spiracles, as well as the reddish edges of the suranal plate and anal legs, decidedly contrasting with the dark hue of the body. The color of the spiracles varies in different individuals, being sometimes mostly white or green or red. Also the yellow color around it is sometimes large and of different width, sometimes being reduced to a line.

The last stage differs from Stage IV in the shorter dorsal horns and caudal horns, those on the sides also being decidedly shorter, and the anal legs are larger, with a wider dark granulated area on the sides, and the body is much thicker and heavier, while the head is pale.

Last (Fifth) Stage.—Length, 10 cent. (Described from one living on the choke cherry.) Head one-half as wide as the body; width, 7 mm.; deep gamboge-yellow, and green on the side; a double deep black frontal line extending from the vertex, diverging below so as to leave a median yellowish line on the upper division of the clypeus. The front division of the clypeus (clypeus anterior), the antennæ, and the base of the jaws yellowish. The thoracic legs and the horns on the second and third thoracic segments and the anal legs with the suranal plate are all of the same color, *i. e.*, deep shining gamboge-yellow. The general color of the body in the green individuals is a delicate pea-green (more usually the individuals are brown or tawny), varying from the shade of the upper side of the cherry leaf to that of the under side, being paler above along the back and especially on the sutures than on the sides. The hairs are long and slender and whitish, most of the dorsal ones as long as the body is thick. There is a prothoracic plate of the same green hue as the body, but with yellowish edges. Of the four horns on the second thoracic seg-

ment, the outer ones are half as long as the inner or dorsal ones, which are 4.5 mm. in length; those of the third thoracic segment are of the same size as those on the second. There are four similar but much smaller dorsal and subdorsal horns on each of the abdominal segments (but they are shorter and more regularly conical than in Stage IV), those on each segment being of the same size, the two dorsal ones being almost three times as large as the subdorsal ones, each dorsal one bearing three terminal spines. Those on the thoracic segments are tuberculated, ending in a fork. On the eighth abdominal segment is a median dorsal horn, now shorter in proportion than in Stage IV, small and short, length 2 mm., nearly twice as large as the other dorsal ones in front, tuberculated and slightly forked at the end, but not so regularly forked as in Stage II. There is a minute median one on the ninth segment, and two minute lateral ones on each side of the segment. The spiracles are very large and conspicuous, yellow with an outer ring of very dark green, which is edged on each side with paler green; those on the prothoracic segment are without the deep-green outer ring. The suranal plate is regularly triangular, gamboge-yellow, with a swollen, rough, coarsely granulated edge, within which the surface is black, with yellow coarse granulations. A similar narrow triangular plate on the anal legs. The middle abdominal legs dark pea-green, with a deep ochre-yellow transverse band above the black planta.

For a careful description of the egg and the larva in its first four stages see Dr. J. A. Lintner's *Ent. Contr.*, ii, 150. His larvæ molted four times, and he thought from the small size of the specimens after the fourth molt, that there might be a fifth one.

The fifth and last stage differs from Stage IV in the shorter dorsal horns and "caudal" horn; the tubercles on the sides of the body also being decidedly shorter, while the anal legs are larger, with a wider, dark, granulated area on the outside. The body is also thicker and heavier, while the head is paler.

It is noticeable that in this form, as in the *Attacinae*, there is a great increase from one stage to another in the size or bulk of the body, while the head does not increase in a corresponding ratio.

SUMMARY OF THE CHIEF ONTOGENETIC FEATURES.

A. *Congenital Characters.*

1. In Stage I there are three pairs of very long dorsal deeply forked thoracic horns, nearly half as long as the body.
2. A similar median spine on the eighth abdominal segment, with one half as long on the ninth.
3. The abdominal segments are transversely banded with black.
4. The lateral spines on the abdominal segments bifid and nearly as large as the subsimple dorsal ones.
5. Body pale chestnut brown; head light reddish.

6. The spiracles minute and difficult to detect, as they are situated in one of the transverse black bands.

B. *Evolution of Later Adaptational Characters.*

1. The forks of the larger dorsal spines disappear at the end of Stage III.
2. The dorsal thoracic spines become recurved in Stage III.
3. The dorsal thoracic and caudal horn become much shorter and stouter in Stage IV, when the characters of Stage V (and last) are nearly assumed.
4. In Stage II the dorsal spines on the prothoracic segment begin to grow shorter and stouter.
5. In Stage II the large horns begin to be less deeply forked.
6. The transverse black stripes disappear at the end of Stage II.
7. The dorsal and lateral spines on abdominal segments 1-7 are much smaller in proportion in Stage III than in Stage II.
8. Towards the end of Stage III the colors of the body become more conspicuous and variable.
9. In Stage III the spiracles become particolored and very conspicuous.
10. The dorsal thoracic and the "caudal horn" become much shorter in Stage IV, and not forked at the tip.
11. The hairs become long and abundant in Stage IV.
12. The body in Stage IV becomes much stouter and heavier than before, while the head has not greatly gained in size proportionately.

LIFE HISTORY OF CITHERONIA REGALIS (FABR.).

For the eggs I am indebted to Miss Morton, who sent them June 25 from New Windsor, N. Y. They hatched July 11. The eggs being indistinguishable in size, shape and color from those of *E. imperialis*, the reader is referred for a description to those of the latter insect. The egg-shell is so transparent that just before the larva hatches it can be seen lying curved up on its side. The head is large and black, while the body is pale, with distinct yellow sutures. Also the black thoracic legs are visible, and the black spots, those on the thoracic segments, elongated; also the dark spines and certain large ochreous patches on the thoracic segments.

Larva, Stage I.—Length, 6 mm. The head is large, wider than the body, smooth and shining black all over, with a few fine dark hairs. The body is cylindrical, black all over, with no stripes or spots of a lighter hue. A pair of large, long dorsal horns on the first thoracic segment, ending in a peculiar bulbous swelling, and on each side of the segment is a smaller subdorsal spine one-third as long as the dorsal ones, which is simple at the end, tapering to a point, bearing a short tine near the middle, and ending in a stout bristle. On each of the second and third thoracic segments is a pair of dorsal horns on each side, or four to each segment. The outer or subdorsal horns are only a little more than half as long as

the inner, but otherwise like the latter; the trunks are spiny, the spinules minute, sharp, nearly equal in size, there being about fifteen to each trunk or stem of the spine. The singular bulbous termination is flattened, rather deeply divided, but somewhat like a chestnut in shape, but wider in proportion, and each side is produced, ending in a blunt spinule, with a stout thick base; the trunk is umber-brown, but the bulbous extremity is blackish brown.

On being touched the larva jerks its head and front body sideways vigorously.

Each of abdominal segments 1-7 has a pair of smaller sharp spines about one-third as long as the longest thoracic spines, which are bent just beyond the middle where it sends off a spur; the end bearing a stout, not very long bristle. Besides these there is a pair of subdorsal spines and a lateral smaller one situated above the insertion of the legs, or six spines to a segment. There is a single median spine on the eighth segment just like the shorter outer ones on the thoracic segments in shape and color, and ending like them in a forked bulbous expansion. Also on the ninth segment is a smaller, shorter, single median dorsal spine, but regularly forked at the end, not swollen. On the tenth segment near the base are two stout, short spines, ending in four branches. Behind them at the end of the suranal plate are four minute spinulose piliferous spines, which are black, all the others in front being brown. The large, broad, squarish anal legs are corrugated on the side. All the legs, thoracic and abdominal, are black. The specimens died before molting.

Fig. 5.—Armature of *Citheronia regalis*. Stage I. *a*, the first abdominal segment, showing the relative position of the spines; *sp*, spiracle; *b*, one of the dorsal prothoracic "horns;" *c*, one of the dorsal horns of the third thoracic segment; *d*, one of the dorsal abdominal spines, those on segments 1-6 not differing in size or structure, near the base are two minute blunt setæ; *e-h*, the armature of the last three abdominal segments; *e*, the caudal horn; *e'*, the subdorsal spine of the same (eighth) segment; *f*, one of the dorsal spines of the ninth segment, which is evenly forked at the end; *g*, one of the large lateral spines arising from the suranal plate (*x*); *h*, the end of the suranal plate. All the figures drawn with the camera to the same scale.

The following description is drawn up from specimens bred at Providence, and described October 10. They fed on hickory, and were sent to Mr. Bridgman from Georgia.

Stage II(?).—(Probably Stage II, as the increase in size between the later stages is very marked.) Length, 25 mm. The head (width, 2.8 mm.) is rather large, rounded, as wide as the body, smooth and shining, mahogany brown, with two faint black shades converging towards the apex. The body is somewhat slender, the skin smooth and dull flesh-brown, with smoky blackish marks, the spines and spinules a little paler than the body and tipped with black. The prothoracic segment is broad, the front edge raised and flaring, with a transverse row of six black spines,

four dorsal and one subdorsal ; of the four dorsal the inner two are about as long as the body is thick, and sharp at the end, with long spinules ; the two adjoining spines are minute. The four spines on the second thoracic segment are much larger, the outer ones on the second and third thoracic of nearly the same size, but the inner two on the third thoracic segment are a little longer than those on the second.

The spines on abdominal segments 1-8 are of even size, and armed with long spinules ; they are about two-thirds as long as the body is thick, and end in two long diverging spinules. On the eighth segment, arising from a large, fleshy base, is a much spinulated caudal spine, nearly half as long as the large thoracic ones ; it is mostly black, but flesh-colored in the middle. Behind it, on the ninth segment, is a median dorsal horn, about one-third as large as that on the eighth.

The suranal plate is small, rough, bearing two large spines ; the end is rounded, with two minute spines between the last pair of lateral spines ; the anterior two of the spines on this plate are larger, but simpler than those on the ninth abdominal segment, and end in four spreading spinules, the main stem being nearly smooth.

The prothoracic segment is blackish, reddish dark flesh color in the middle ; the second thoracic segment is of nearly the same color, but the third is entirely black. The stigmata are black, surrounded by a blackish cloud, while in front is a velvety black oblique dash, and beneath a flesh-colored oblique raised ridge or fold. All the legs, both thoracic and abdominal, are black ; the anal pair are large, rough and black. There is a large spine under each spiracle.

Stage III.—Length, 30-35 mm. Molted on the morning (9 A.M.) of October 10. When first seen the color of the body was uniformly purplish flesh color, with black markings. The head (width, 4 mm.) is dark chestnut brown, with the clypeus and adjoining parts pale. *It differs from the preceding stage in the considerably shorter abdominal spines, while their spinules are somewhat larger in proportion than in the previous stage.* The thoracic spines are about, or a little more than, twice as long as the body is thick, and the abdominal spines are about one-third as long as the body is thick. The lateral oblique fleshy fold on the abdominal segments have a more distinct dark dash above than in the preceding stage. The legs are black. The caudal spine is now about one-third as long as the larger thoracic ones, being in the former stage about, not quite, one-half as long as the longer thoracic spines.

By 2 P.M., October 10, the thoracic and caudal spines, at first pale flesh color, became black, and the head and thorax, as well as the body generally, had turned darker.

It assumes, like *E. imperialis* and *S. bicolor*, a Sphinx-like attitude, so that this feature is possibly inherited by the Sphingidæ from the Ceratocampidæ or a similar group. The thoracic and caudal spines are somewhat sensitive to touch by an intruder.

Last Stage.—I will first describe an alcoholic specimen, 45-50 mm. in

length, which at first I thought must belong to a fourth stage, or at least one before the last, but as the head is of nearly the same size as full-grown specimens, I am inclined to regard it as simply a belated individual, or one which had recently molted, and had not fed up so as to fill out to its full size.

Length of body, 45-50 mm.; breadth of the head, 6.5 mm. The head is yellowish brown, with a dark spot on each side of the head opposite the apex of the clypeus. The two dorsal prothoracic spines are nearly as long as the head is wide, but without the long slender spinules of the previous stage; they are yellowish, but black on the distal third; the third or metathoracic pair are a third longer than the body is thick, and like the others, with short, stout spinules. The abdominal spines are now much shorter than before, with short spinules, though slightly longer than in the fully grown examples. The "caudal spine" on the eighth abdominal segment is as in the full-sized specimens. The general hue of the body is as in the full-grown larva, but the thoracic dorsal black spots are smaller, though the metathoracic segment in front of the horns is deeply stained with black.

Full-grown Larva.—Length, 125 mm.; thickness of the body, 20 mm.; width of head, 7 mm. The head is about one-third as wide as the body rounded, smooth, free from hairs, and yellowish, not spotted on the sides, and not banded as in *Eacles imperialis*. The body is cylindrical; the skin smooth and shining, not granulated, as in *Sphingicampa* and *Eacles*. The two middle prothoracic spines are large and long, being nearly as long as the head is wide, but the spinules, like those of the other "horns," are now short, thick and acute, not long and slender as in the previous stages; length, 6 mm.; they are yellowish and black on the outer third. This and each segment of the body succeeding have six well-developed spines, except the eighth and ninth abdominal, which have each an additional spine, the large median one. The two large median horns on the two hinder thoracic segments are each about 20 mm. in length; the horns of the second row corresponding to the subdorsal or supraspiracular row of the abdominal segments, being about half as long (10 mm.) as the dorsal ones; they are also yellowish and blackish on the outer third. All the six abdominal spines of segments 1-7 are now very small, slender and only about twice as long as the large dorsal horns are thick at the base; viz., 4 mm. in length. Unlike the full-grown *Eacles*, the supra and infraspircular spines are as well developed as the dorsal ones. On the eighth and ninth abdominal segments the "caudal horns" are supplemented by two small, slender spines, situated just behind the large median horn. Whether these have any morphological significance is doubtful; they do not exist in *Eacles*. Length of the "caudal horn" on the eighth segment, 9 mm.; that on the ninth segment being one-half as long. The suranal plate is triangular, the surface rough, with two small tubercles on each side, but no spines. The anal legs are very large, subtriangular, with the outer surface rough, and on the

lower edge above the planta is a group of seven or eight minute spines ; a similar group of minute spines occurs near the end of the middle abdominal legs.

For the colors the reader is referred to the description and figure by Riley, of the living animal, in the *American Entomologist*, i, 230. We have not yet seen a full-grown living larva. The foregoing description has been drawn up from four well-preserved alcoholic specimens.

This larva differs generically from *Eacles* in having well-developed dorsal spines on the prothoracic segment ; while the lateral ones along the abdominal region are also well developed, these being nearly obsolete in *Eacles*. The genus *Citheronia* is unique in having seven spines on the eighth and the ninth abdominal segments respectively. All these characters are seen to be secondary and adaptive, and yet they are good generic characters, showing that the acquirement or loss of generic characters is due to adaptations to the surroundings. The specific characters are well brought out by comparing *C. regalis* and *C. sepulchralis*.

RECAPITULATION OF THE SALIENT FEATURES IN THE ONTOGENY OF CITHERONIA.

A. *Congenital Characters of the Larva, as seen in Stage I.*

1. The three pairs of enormous spines ; the first or prothoracic pair but little shorter than the third, and the middle pair about two-thirds as long as the body, all ending in a swollen, triangular, two-horned flattened bulb ; these appendages being deterrent and for offensive use in the earliest as well as latest larval life.

2. Both the eighth and ninth abdominal segments bearing a high median dorsal horn ; and these segments bearing seven, instead of only five, spines.

3. The lateral spines on the abdominal segments nearly as large as the dorsal ones.

4. Body dark ; head dark in color.

B. *Evolution of Later Adaptational Characters.*

1. The bulbous tips of the thoracic horns dropped at the end of Stage II (?).

2. The thoracic horns become curved in Stage II or III (?).

3. The thoracic dorsal spines become much stouter, with much shorter and stouter spinules at the last molt.

4. The mature larval features mostly assumed in Stage III.

5. The dark colors exchanged after the last molt for pale green, with bluish tints.

6. The black dorsal thoracic spots and the lateral yellowish bands most showy in the last stage.

Attention should be drawn to the colossal size of this larva, as compared with that of *Sphingicampa* and even *Eacles*, though the head is not so

much larger. This is due, perhaps, to its sluggish life, greater digestive and assimilative powers, so that a rapid acceleration of the growth of the body takes place; owing to its protection from the attacks of birds it may feed openly and continuously. It is thus like Spingid and Attacine larvæ in its huge body and enormous appetite. The largest Cochliopod larvæ are the spiny ones, and the spiny or tuberculated Saturnians and Attacinae have thick, large bodies.

FAMILY HEMILEUCIDÆ.

NOTES ON THE EARLY STAGES OF HYPERCHIRIA IO (FABR.).

At Brunswick, Me., the eggs were laid in confinement, June 5-7, and the larvæ hatched June 25, or about three weeks afterwards. Another year, larvæ in the second stage were observed July 16. For an excellent but brief description of all the stages see Riley's *Fifth Rep. Ins. Missouri*, 135; also Lintner's *Entomological Contributions*, ii, 146. Both authors state that there are six stages.

Egg.—Length, 1.8 mm.; width, 1.4 mm. It is regularly oval-cylindrical in form and slightly flattened; yellow during early embryonic life, with sometimes an orange spot on each side. Under a high-power triplet the surface of the shell is seen to be very finely granulated (not smooth and shining), and under a one-half-inch objective the surface is seen to be divided into close-set, very small, slightly raised but flattened areas, separated by narrow valleys; the areas are very irregular, but often are somewhat polygonal in outline.

Larva, Stage I.—Length, 5.5, when freshly hatched; the head, 0.8 mm. in width. The body is uniformly yellowish brown; the head and spines are dark, blackish brown. All the feet, both thoracic and abdominal, are of the same color as the body. The spines are in four rows, *i. e.*, there are eight on each segment, except on those bearing the abdominal legs, when the smallest or infraspicular ones are wanting. The eversible glands are well developed; a pair on the first and a second pair on the seventh abdominal segment; they are situated behind the spiracle of their segment and between the subdorsal and spiracular row of spines. The spiracles are very small and hard to detect in this stage. The subdorsal spines are about as long as the body is thick, the dorsal ones a little thicker and longer; they end in usually fine setæ, one of which is finely barbed about as long as the spine itself. Both the subdorsal and dorsal spines of the three thoracic and of the eighth and ninth abdominal segments are deeply forked, the forks of equal length and each bearing the long bristle as well as four or five short ones. Those of the other segments are not forked. The first thoracic dorsal and subdorsal spines are as long and large as those on the two hinder segments. The spines are represented in Fig. 6.

Fig. 6 represents the freshly hatched larva, drawn with the camera, with the lateral, eversible glands (*g*).

Fig. 7 represents the armature of the three thoracic segments. *Pp*, the prothoracic shield ; I, II, III, the bifid dorsal spines of the three thoracic segments, about three-fourths or four-fifths as long as the segments are thick ; *sd'*, *sd''*, *sd'''*, the bifid subdorsal spines ; *s'*, *s''*, *s'''*, the spiracular spines ; the prothoracic ones throw off a bristle near the middle ; in those behind this bristle is wanting ; they are inserted just in front of the spiracle, the corresponding ones, however, on the abdominal segments being situated just below the spiracles ; *i'*, *i''*, *i'''*, the small infrspiracular spines which are about half as long as the spiracular ones ; *l'*, *l''*, *l'''*, insertion of the thoracic legs.

Fig. 8 represents the armature of some of the other segments. A, the third thoracic and the first and second abdominal ; III, I', II'', the dorsal spines ; and the other lettering as before ; *sp*, the spiracle ; *g*, the lateral eversible gland of the first abdominal segment. B, the sixth to tenth (and last) abdominal segments ; faint traces of the spiracular and infrspiracular yellowish lines are to be seen, hence the medio-dorsal, the subdorsal, and the two lateral longitudinal lines of the larva in its second stage are already indicated in the first stage. The abdominal legs each bear eight ungues, or four on each side ; and all except the anal legs bear a piliferous wart just above the planta ; *sp*, the rugose suranal plate, bearing five piliferous warts on each side ; *lp*, the lateral plate of the anal legs, with three or four piliferous warts.

Stage II.—Length, 7 mm. ; width of head, 1.3 mm. The head is chestnut-brown. The body is uniformly reddish amber-brown ; the spines are blackish brown, with the spines black at the tip. *The dorsal and subdorsal spines are now approximate in shape to those of the last stage, being bulbous at base, and with radiating stout spinules, but the latter are less in number than in the fifth and sixth stages.* The dorsal spines of the prothoracic segments are bifid, the forks of the same length, and each bearing a long hair ; along the trunk are pale scattered tubercles, each ending in a long hair. The second thoracic dorsal spines have but one terminal piliferous spinule and a single lateral one, the other spinules ending in a sharp black point. The third thoracic is like all the abdominal dorsal spines which bear radiating spinules, not ending in a single piliferous spinule, as in *Fig. 9, vi*.

Fig 9, sd''', represents a spine of the subdorsal series, the one figured being that on one side of the third thoracic segment, but those on the abdominal segments (except x) are like it, though most of the abdominal ones have two or three small tubercles near the base which bear barbed bristles, as at *sd^{vi}*. All the long setæ bear a few minute barbs.

In Stage IV (?), when the larva is 20 mm. in length, the prothoracic dorsal spines are nearly twice as long as the second thoracic ; the latter, however, have more spines at the base than those in front, and the lateral terminal are a little shorter than those on the first thoracic segment. The two dorsal spines on the third thoracic segment are, in size and spinulation, now exactly like those on the abdominal segments 1-9. The

median double one on the eighth abdominal segment is thicker than the single ones in front, also higher, and ends in two spines; the lateral spines are much more numerous than those in front. The spines of the subdorsal series are alike on both the thoracic and abdominal segments.

Last Stage.—The shape of the dorsal spines of the larva in its final stage is represented by Fig. 10. I, a prothoracic dorsal spine, ending in two equal terminal piliferous spinules, with seven or eight just below it, while at and near the base are the long, pale spines, each ending in a sharp black point; II, one of the second thoracic dorsal spines, the base short, bulbous, with very numerous radiating spines, and a single terminal, central piliferous spine, with a smaller one near it; III, a bush-like dorsal spine of the third thoracic segment, no piliferous spinules present. The abdominal dorsal spines are all on the same type.* The median spine on the eighth abdominal segment is about twice the size of the other dorsal single ones in front, though no higher, and it spreads more, having about twice as many spines on the sides. On the ninth segment are two dorsal and two subdorsal ones, and behind these four on the same segment is a median one. *These types are already attained in Stage II, though the spinules are fewer in number.*

It is to be noticed that the characters of the full-fed larva appear in large part in Stage II, and are almost fully developed in Stage III.

Fig. 11 represents the spiracle and lateral eversible gland of the full-fed larva; *g*, the eversible gland; *sp*, spiracle; *g'*, an eversible gland, enlarged.

In the large dark (in alcohol) larva of *Hyperchiria*, or perhaps of a *Gamelia*, referred to by me in *Proc. Bost. Soc. Nat. Hist.*, xxv, 91, the dorsal spines of the three thoracic segments are represented by Fig. 12. I, a prothoracic; II, one from the second thoracic; III, one from the third thoracic; VII, one from the seventh abdominal segment. It will be seen that the spines of this species are rather more generalized than in the mature *H. io*, and approximate those of the second stage of that species; the dorsal spine of the third thoracic segment ending in three piliferous spinules, there being no piliferous spinules at all in the homologous spines of *H. io*; the abdominal spines also (VII) ending in three piliferous spinules, though the other spinules are much (about one-half) less numerous.

Intermediate between those of *H. io* and the Mexican species is the *Hemileuca artemis*, from Las Cruces, New Mexico (Fig. 13), in which the prothoracic dorsal spine is like the Mexican form, the second thoracic dorsal spine like the prothoracic ones of *H. io*, and the third thoracic dorsal tuft like the second dorsal one of *Hemileuca yavapai* from Arizona (Fig. 14). In this last species the dorsal tufts of the body, as a whole, are intermediate between *H. maia* and *H. io*, but as regards the second and third dorsal and the dorsal abdominal ones, it approaches much

*The spines have been somewhat flattened in the animalcule box, but have been drawn with the camera.

nearer to *H. io*, as will be seen by an examination of the figures, the second and third thoracic spines being alike in shape. Hence the most generalized or primitive form, as regards its larval armature, appears to be the genus *Hemileuca*, and *H. maia* is the most like the young larva of *Hyperchiria io*; then succeeds the Cordova larva, then the New Mexican larva, while *Hemileuca yarapai* is more modified, *Hyperchiria io* being the most so of any under consideration and this may have been the last to be evolved.

THE YOUNG LARVA OF HYPERCHIRIA IO VAR. LILITH (Strecker).

About a dozen living specimens of these interesting caterpillars were kindly presented to me by Mrs. Annie Trumbull Slosson, who had collected them at Punta Gorda, Fla., where they were found in March feeding on the mangrove. They were described April 6. Mrs. Slosson considered them as belonging to Strecker's var. *Lilith*.

Length, 20-25 mm. The body is yellowish green all over. The lateral broad, reddish, spiracular band is as in northern specimens of *H. io*; it is broadly and distinctly bordered below with white. The head and all the legs, both thoracic and abdominal, are straw-yellow. The spines in general are bright, straw-yellow, more yellow than the body; the ends of the dorsal ones on the prothoracic segment are black, while the ends of the long spinules in general are more or less black, some merely tipped with black.

This is apparently a case of acceleration of development, as *the larva in its second (or third) stage resembles in coloration the full-grown northern form of the larva of H. io*, the markings, including the lateral reddish and white spiracular line, being as in the full-fed normal larva of *H. io*, and the general color of the body and spines being yellow, instead of gray and reddish, as in the normal *H. io* in its second and third stages.

NOTES ON HEMILEUCA MAIA (DRURY).

Stage I compared with that of H. io.—In this stage *maia* is very similar to *io*; only the bifid dorsal tubercles or spines have shorter branches, the spines themselves being a little shorter, while the longest bristle is longer, the other bristles arising from the end of the spines being fewer, indeed only one, instead of three or four, as in the abdominal segments of *io*. The medio-dorsal spines on the eighth and ninth abdominal segments are much shorter and with a shorter fork, but with as long or slightly longer bristles arising from the forks. The larvæ of the two forms are of the same size.

Stage II (or III?).—*Maia* in what appears to be the second stage differs from *H. io* in its second stage in having much longer dorsal spines, with very much longer spinules. Thus the generic characters appear in the second stage, as in *H. io*.

THE LARVA OF *HEMILEUCA ARTEMIS* sp. nov.*

Several full-grown larvae were received from Las Cruces, New Mexico, kindly sent me June 15, 1891, by Mr. C. H. Tyler Townsend; they were found feeding on a species of long-leaved willow, and on a populus. Mr. Townsend writes regarding these caterpillars:

"I am informed that in previous years this caterpillar has been extremely abundant here, almost denuding the cottonwoods (*P. fremontei*). They are said to appear in force later in the season. I rather doubt this, but will look out for more."

Mature Larva.—Length, 45 mm. The body is long and thick, of the general shape and thickness of *H. io*, rather than of *H. maia*. Head dull shining red, about half as wide as the body in the middle. Segments of the body each with an irregular, deeply impressed, transverse wrinkle, just behind the middle. A moderately large prothoracic plate, which is irregular in shape and divided in the middle into two pieces; it is dull reddish honey-yellow or chitinous in color. On the prothoracic segment are eight large, high-branched spines, as large as any of the others on the body behind; they are black, with the spinules black at base, pale flesh color beyond; the terminal bristles are dark; there are about 16–18 spinules on each spine, nearly as in *H. maia*, and the prothoracic spines of *H. io*. The spines on the second thoracic segment are similar in shape and length to those in front, but slightly shorter and with a smaller number of spinules towards the end. On the third thoracic, to and including the seventh abdominal segment, the two rows of dorsal spines are like those of *H. io* behind the prothoracic segment, being short, thick, bushy spines, with numerous radiating, yellow spinules, which are black at tip. On the eighth segment there is a single, slightly larger one, with two central spines, one on each side. Those on the ninth segment are like the prothoracic ones, the median one being of the same size as the lateral ones. There are no spines on the tenth or last segment. There is a subdorsal and an infraspicular row of spines like those on the first thoracic segment along the sides of the abdomen, but on the thoracic segments are two rows of infraspicular spines. There is a rather large, broad, V-shaped or short subcordate plate on the tenth segment of the same color

* *Hemileuca artemis* sp. nov. 1 ♀ with wings not fully expanded. At first doubtfully referred to *H. juno*, I find on comparison with my types in the Museum of Comp. Zoölogy at Cambridge that it is quite different. The head and body are larger. The thorax is much more white, both on the prothorax and on the patagia, which are entirely white. The disk of the mesothorax is brown; the two tufts, one on each side behind, are orange-red, instead of claret-red as in *juno*, and the hairs between the forelegs and those on the fore femora are of the same deep orange-red as the thoracic tufts. *Juno* has more reddish hairs on the end of the abdomen, where they are all white in *artemis*. The fore wings are white, with a black-brown border all around, completely enclosing the entirely opaque black-brown discal spot, which, in the unexpanded specimen, does not enclose (as it does in *juno*) a lunate white spot. The blackish costal edge is as wide as the outer edge. The hind wings are apparently much as in *juno* and in *grovi*. It does not agree with the description of *grovi* (*Trans. Amer. Ent. Soc.*, ii, 192, Pl. ii, Fig. 60, 1868).

as the prothoracic plate, and a bristly, concolorous plate on the outside of the anal legs.

The body is smooth, without the granulations of *H. maia* and without the lateral reddish band of *H. io*. The body is pale, sea-greenish, with irregular brown spots and slashes in the spaces between the spines of the subdorsal rows, and they also occur lower down near the spiracles, which are yellow, edged with dark brown. Thoracic legs dark honey-yellow; abdominal ones washed with cherry reddish.

The eversible glands were not everted in any of the six specimens, but their position is indicated, as in *H. maia*, by an irregular oval, liver-colored patch behind the first thoracic and eighth abdominal spiracles.

Fig. 13 represents the dorsal spines of the three thoracic segments respectively. I, one of the dorsal prothoracic spines, in which the spinules, with long setæ, are scattered along the whole length of the main trunk; II, one of the dorsal spines of the second thoracic segment, surrounded at the base by a dense thicket of acute spinules, the latter not bearing a terminal seta; III, a dorsal spine from the third thoracic segment, forming a short, broad tuft or clump of non-setiferous, but acute spinules, the clump having a broad base, from near the centre of which arises a long spinule, bearing a slender seta, like those near and at the ends of those in front. The two dorsal rows of abdominal spines extend back to and including the seventh uromere.

FAMILY LASIOCAMPIDÆ.

On the Flattened and Scale-like Hairs of the Lasiocampidæ.—Dr. T. W. Harris* describes an Acronycta larva, *A. americana*, as "beset with a few long black bristles dilated at the end," and again says, "the long, black, spear-headed hairs grow from the skin and not from warts." A year or more ago, in examining the median dorsal tufts on the second and third thoracic somites of the European *Gastropacha quercifolia*, I found that they were composed of broad lanceolate oval scales, which were opaque and dark steel purple in color, with the surface quite regularly striated, though not invariably so. The striæ do not appear to extend to either end. They vary in shape and in size, some being narrow and with a simple point at the distal end, while the majority are variously notched or toothed, as shown in *Fig. 15*. They thus appear to be true scales, like those on the wings of Lepidoptera, etc.

In the same species the lateral tufts along the body contain each a few long hairs with flattened ends, the latter varying in shape from oval to triangular, with the ends often very broad and ragged, with from one to four very irregular teeth. No striæ are perceptible, and the hairs throughout are pale, colorless and transparent (*Fig. 16*).

* *Entomological Correspondence of T. W. Harris*, edited by S. H. Scudder, Boston, 1862, Pl. iii, *Fig. 2*. The same larva has also been figured in my *Guide to the Study of Insects*, *Fig. 236*.

Fig. 15—Scales from the dorsal thoracic tufts of *Gastropacha quercifolia*.

Fig. 16.—Hairs with flattened ends, all from a single lateral tuft. *a*, a hair ending in two slender points, the only one seen.

On examining the lateral tufts of *Gastropacha americana*, I found some very long similar hairs flattened at the end and of extraordinary form, usually projecting beyond the simple hairs; some ending in regular lanceolate-oval shapes, with the point much attenuated, others broader, while some are oval and broad at the end, which terminates in a fine attenuated point, with usually three minute teeth at the base. They are similar in shape to those of *Gastropacha quercifolia*.

On turning over the beautiful plates of Burmeister's Atlas of the Lepidoptera of the Argentine Republic, I found that the author represents on Pl. xxii, Fig. 9, similar long hairs, much flattened and expanded at the ends, with 3, 4 or 5 long slender teeth, in the larva of his *Clisiocampa proxima*,* which, however, seems to differ from *Clisiocampa* proper. The hairs are visible to the naked eye, and are much more regular than any I have seen, and are also striated, with beads or clear spots.

In *G. americana*, the scales forming the dorsal tufts both on the two hinder thoracic segments and on the eighth abdominal one are very different from those of the European species; they are dark and opaque, but are long, narrow, flattened, very gradually increasing in width to the end, which has a single notch, and from the single notch an impressed line or stria extends along the middle for some distance.

Fig. 17.—Scales from the tuft on the dorsal tubercle of the eighth abdominal segment. *a*, the setæ $\times \frac{1}{2}$ in. obj.; *b*, *c*, similar ones $\times \frac{1}{3}$ A eyepiece.

Fig. 18.—Flattened hairs from the lateral tufts of the second and third thoracic segments of *G. americana*, color pale brown.

These flattened hairs seem common to the family of Lasiocampidæ, and should be looked for in the European species of this group. In *Heteropacha rileyana* there are no dorsal scales, but some of those in the lateral tufts have flattened ends, which are very long and slender, lanceolate-oval, with the tip much attenuated.

Fig. 19.—Flattened hairs from the lateral tufts of the second thoracic segment of *H. rileyana*.

I have been unable to discover these singular scales and flattened hairs in *Clisiocampa americana*,† or *C. neustria* of Europe, or in any other family

* Burmeister (p. 52) remarks: "Stoll has figured (Suppl. de Cramer, Pl. xix, Fig. 5) a similar larva with the same hairs, à *palatte terminale*, situated on the first and last rings of the body." He names it *Bombyx cyphonia* (Pl. xxxv, Fig. 6, of the same volume). Walker refers this species with doubt to the genus *Oxytenis*. Burmeister adds: "Some other species of the genus *Clisiocampa* have the same hairs placed at the two ends of the body."

† In *C. sylvatica* the hairs on the lateral thoracic tubercles are tapering and finely barbed, with scattered slender spikes like smooth simple setæ.

In *Tolype villosa* there are no such scales or hairs with flattened ends as in *Gastropacha*, those on the dorsal tubercles of the thoracic and eighth abdominal segments being simple, tapering, with large scattering spike-like dark opaque setæ, these latter being perhaps the homologues of the dark scales of *Gastropacha*.

of Lepidoptera, except in the hairy Noctuidæ or Noctuo-bombycæ, or Bombycoidea, where the hairs with flattened ends probably occur in the more hairy and penciled species. In the larva of the common American *Acronycta hastulifera*, many of the barbed hairs forming the black pencils are flattened at the end and black, but not striated.

Fig. 20.—Flattened setæ of various shapes, usually pointed. *a*, a small one; *b*, its barbed base; *c*, portions of the white barbed hairs; *d*, one blunt and notched at the end; all $\times \frac{1}{3}$ in. obj., and from tuft on the third thoracic segment of *A. hastulifera*.

These specialized and highly differentiated setæ, so like the scales of adult Lepidoptera, appear to be of use in rendering the pencils and tufts more conspicuous and stiff. The shortest and broadest, striated, scale-like setæ occur on the low, broad, stout, dorsal median tubercles of *Gastropacha*; and, perhaps, add a repellent nature to these shiny dark metallic tufts. At all events the occurrence of such scales is an interesting example of the acceleration of development of the setæ in these larval forms, and it is not improbable that in the ancestors of the *Lusiocampidæ* they were characters acquired during the later stages of their larval lifetime.

PARTIAL LIFE HISTORY OF *CLUSIOCAMPA THORACICA* (Stretch).

Specimens in the third (?) stage were mailed April 28 from California by Mr. L. E. Ricksecker, and received and described May 5. It was feeding on willow leaves, but will eat sparingly of the eastern wild cherry. It has the same habits as the eastern *C. sylvatica*, spinning a web and living in clusters.

Larva, Stage III(?).—Length, 10–12 mm. In this stage it closely resembles *C. sylvatica* when next to the last molt, both in the shape and color of the exclamation-point-like pale dorsal spots; in having on each side an ochre-brown subdorsal line, though it is more broken, and a distinct, broad, lateral line, which is edged above and below with black. Below this line, low down on the sides of the body, are two whitish, reddish-yellow, wavy, irregular thread-lines, the lower one a little more distinct and pale tawny. The upper of these two lines is present in *C. sylvatica* (but the lower one is not present in Bridgman's drawing). The space between these two lines is somewhat livid, with pale blue and black dots.

The head is pale blue, with fine black dots, which are thickest on each side of the median line, and in the middle of each side. The prothoracic segment is bluish, with a median black hair-line, with two converging, lateral, black patches in front, and two shorter ones behind. The hairs on the body are deep tawny, those on the sides, low down, mixed with gray hairs.

Stage IV(?).—Length, 20 mm. Molted about May 10, observed from May 11 to 16. The marks and spots, especially the blue ones, are much more distinct than before. The black dots on the head are arranged more regularly than before, forming a triangular area on the vertex and

including the median suture, while there are two areas on each side containing the black dots, the lower group situated behind the eyes. The yellowish-white dorsal, median, exclamation marks are on a black field. The broad, now very distinct sky-blue subdorsal line is irregularly edged with black and above and below with a distinct, ochreous, wavy line. The blue line is, on the second and third thoracic segment, interrupted by a conspicuous square black spot, and a similarly situated black dot in the middle of each segment appears on the lower edge of the blue band, being a local dilatation of the lower black edging of the blue band. The eighth abdominal segment is slightly humped, and on the side the subdorsal blue band ends in a squarish black spot. The two lower ochreous lateral lines are distinct, the lower one extending along the base of the legs. The hairs are now snuff-colored; those on the sides, low down, being mixed with whitish ones.

Stage IV(?).—May 18 it molted again, its length being 18–21 mm. It is now quite different from the former stages. The yellowish-white exclamation point is now less distinct, the dot often obsolete, and the mark is now ochreous and white in the centre. The previously black dorsal band enclosing the median series of exclamation marks is now partly filled with blue specks, and *contains traces of a much interrupted wavy, deep reddish ochreous line*. The lateral blue lines and sides of the body in general are scarcely different from the former stages, though the red thread lines are deeper in hue. The hairs above and on the sides are now rather denser and more decidedly snuff yellow (the short, red, wavy lines in the dorsal spaces are new to this stage).

FINAL STAGES OF CLISIOCAMPA THORACICA (Stretch).

Received living from Mr. Ricksecker, May 5, having been fed on willow. Length, 28–30 mm. This belongs to the same stage as that described May 18, in my notes, but the dot of the exclamation mark is less distinct, the markings are more distinct, and the larva is larger, and they feed better. The blue and snuff or deep ochreous wavy spots and short lines are more distinct. Of the very irregular blue spots there are three on a side of the dorsal space on each segment enclosed by the subdorsal, reddish, ochreous lines. The second or lateral line is now, instead of being reddish ochreous, decidedly yellowish ochreous. May 27, one has molted to the last (?) stage. This larva is interesting as passing through a *sylvatica* stage with its dorsal exclamation mark.

The following description is drawn up both from living specimens and blown ones loaned by Prof. Rivers and named *thoracica* by him.

Full-fed Larva.—Length, 45 mm. Head deep blue, with two series of fine black dots along the top, and another broader series along the sides; with a clear bluish space between. The prothoracic or cervical shield is more distinct than in any others of the California species which I have seen, as it is freer from hairs and marked with blue; it bears two black

dots in front and one on each side. There are four subdorsal, ochreous, rust-red, fine, wavy, irregular lines, which are broken at the sutures and enclose three still slighter and much less regular more broken dorsal lines. Near the front of each segment these three short dorsal lines more or less unite to form a conspicuous oval, dull ochreous-red spot, irregularly centred with a paler hue; the spots on the second and third thoracic segments being paler and running more into each other. The ground color of the body is dull bluish, with black specks. The dot of the dorsal ochreous exclamation mark is now nearly or quite obsolete, sometimes represented by a few scales or irregular dots, and the main mark is itself sometimes irregular and reduced in size. On each side, just behind each exclamation mark, is a conspicuous black dot, and another similar pair behind, making four conspicuous dots, the anterior two more distinct than the others.

There are two irregular, subdorsal, wavy, Scotch-snuff-colored thread-lines edged with black. The pale sky-blue field of the back of each segment is divided by the two black spots into three bluish patches on each side of the dorsal area. The sides of the body blue, speckled with black. A lateral pale snuff line above the spiracles edged with black, which gathers in the middle into a dot, which is situated above the spiracle. A faint, double, flesh-colored, infrastigmatal line, very irregular, sometimes sending streaks towards the black spiracles, the lower of the two lines forming elongated patches at the base of the legs, the two lines being more or less confluent on the thoracic segments. In some specimens there is only a short, broken, snuff-colored line at the base of the abdominal legs; and a snuff-yellow dot on each side of the first thoracic segment.

The body is less hairy perhaps than in any of the other species. There are a few long, dark, dorsal hairs, with an undergrowth of fine ochreous hairs, and on the sides of the body below the spiracles are lateral, whitish gray, rather dense hairs, directed downwards. The hairs are longest on the thoracic and eighth abdominal segment, the latter being well swollen or humped on the back.

The body beneath is livid bluish, with pale flesh-colored patches on the front of each abdominal leg, except the anal pair.

This species differs from *C. fragilis* or *C. californica* in the rather less hairy body, and the four subdorsal rust-red lines, enclosing the three dorsal, short, rusty, broken lines which in front of each segment form a distinct, short, oval, reddish spot; and also in the distinct bluish cervical shield.

CLISIOCAMPA CONSTRICTA (Stretch).

The following description was drawn up from blown specimens kindly loaned me by Prof. J. J. Rivers, of the University of California.

Full-fed Larva.—Length, 46–48 mm. Head mottled with dull blue and black spots, the spots not arranged in lines, as they are in *C. thoracica*. The body is rather more hairy than in the other Pacific coast species, and

there is no distinct cervical shield. There is a dorsal row of about twenty ochreous rust-red patches, very irregular in shape, connected by two short parallel wavy lines of the same color. Each spot is situated on a deep velvety black field, ending behind in two conspicuous large black dots. From each red patch arise numerous hairs, forming a wedge-shaped ochre-yellow tuft. The ground color of the body is deep blue, spotted and mottled with black. There is a lateral row, one to each segment, of black dots, irregularly surrounded by ochre-red. Just below is a row of conspicuous short, thick tufts of white hairs situated near the front edge of each segment. Below each black spiracle is an obscure flesh-colored diffuse patch enclosing a small black dot, while beneath is a long black patch. All the legs, both thoracic and abdominal, and the under side of the body are livid blackish. The few dorsal hairs (the ochreous ones excepted) are black, those on the thoracic segments being longer than the others, while the lateral and ventral hairs are grayish, with an intermixture of ochreous ones.

The larva of this species differs from all the others of the genus known to me by the large, conspicuous, ochreous-red, dorsal spots giving rise to the peculiar wedge-shaped ochreous tufts, and by the lateral row of short white tufts, while the body in general is much more hairy than in the other species. No eastern species approaches it in these characters.

CLISIOCAMPA FRAGILIS (Stretch) (?).

This larva, referred with some doubt to the above species, was received from Mr. J. J. Rivers, who collected it in the Sierra Nevada. The following description was made from a blown specimen :

Full-grown Larva.—Length, 42-44 mm. Head bluish, mottled with heavy coarse black spots, with a tendency in their arrangement similar to that in *C. thoracica*. The cervical shield is very indistinct. The body is pale blue, with black specks and very irregular fine ochreous-red lines, more or less broken and confluent on the first three or four segments. The species is at once distinguished by the dorsal row of long, narrow, whitish-blue, distinct spots, beginning with the second thoracic segment, each spot extending nearly the whole length of the segment. On each side of the same segments are two large, conspicuous, irregular spots of the same color, beneath which is a band made up of broken, irregular, ochre-red hair-lines. The spiracles are situated in a broad bluish band. Body beneath black, with pale flesh-reddish or ochreous patches between all the legs, both thoracic and abdominal. There is a black dot near the base of the four median pairs of abdominal legs. The hairs above are rather denser than in *C. thoracica*, and ochreous; those on the side are ochreous running into gray, those on the sides of the thoracic segments being whitish.

This larva is at once known by the conspicuous, long, dorsal, pale-blue, almost whitish-blue spots, flanked on each side by two large, distinct, irregular spots of the same hue, with the space between conspicuously

deep black. Also by the numerous close, broken, fine, dorsal, alternating black and ochreous lines.

Two specimens of the same larva were collected by myself in the middle of June at Virginia City, Montana. It has the same markings, but the blue patches on the side are not so distinct, as they merge into the blue of the side of the body. On this account the black spots between the two blue patches is more distinct. In one example, however, the lateral blue spots are present. The markings on the head and the irregular ochreous-red lines on the anterior part of the body are just the same in the Montana example.

PARTIAL LIFE HISTORY OF CLISIOCAMPA DISSTRIA Hübner (SYLVATICA Harris).

Of this caterpillar about a dozen described below were found on an oak leaf at Providence, May 24.

Stage III(?).—Length, 10 mm. Head not so wide as the body, black. The shape of the body is as in *C. americana* of the same age. The lateral prothoracic and other thoracic piliferous warts as in *C. americana*, but the markings are already very distinct. The prothoracic shield much as in the other species. There are four large, conspicuous, lateral, black, raised spots, two on the second and two on the third thoracic segment. The body is blue above, with two contiguous, parallel, broken, black lines, each dorsal bordered externally by a broken, deep, straw-yellow line, which widens on the sutures. *These black lines are wide, and in most of the specimens so encroach on the blue band, on abdominal segments 1-7, as to break it up into a median row of more or less pear shaped blue spots, which are diagnostic of the species*; thus the specific characters appear in this stage. Two lateral, linear, white lines enclosing a broad, blue stripe, the latter edged with a fine, broken black line. Abdominal segments 8 and 9 dull, livid blue. The body beneath is pale, livid, whitish. The thoracic legs are black; the abdominal legs with a black spot on the outside near the end.

The body is not quite so densely hairy as in *C. americana*, but the hairs are of about the same color, being pale brown above and whitish on the sides of the body and beneath.

In these examples the row of dorsal spots are seen to originate from the breaking up of the median blue band, owing to the encroachment of the black border.

LIFE HISTORY OF CLISIOCAMPA CALIFORNICA (Pack.).

I owe to the kindness of Mr. Cockerell a mass of eggs received from West Cliff, Custer county, Colo., and which hatched at Providence, April 14-15.

Larva, Stage I.—Length, 3 mm. Head and body of nearly the same proportions as in *C. americana*, but decidedly thicker and stouter, though

no longer. The color of the head and body are the same, being dull black, the head somewhat polished. The hairs are white, uneven in length, and, as in *C. americana*, a few are yellowish gray. The piliferous warts are distinct and rough. There is on each side of the median line of the body a row of about seven small but distinct, transverse, snuff-yellow dorsal spots, beginning on the first abdominal and ending on the seventh segment, there being more to be seen on the thoracic segments; they almost form a transverse linear spot, but are interrupted on the median line, though often continuous on the hinder edge of the segment, yet sometimes they are separate and the spots are narrowly triangular, the apices pointing outward away from the median line of the body.

Stage (?).—Length, 25 mm. The distinctive marks of this stage is *the row of lateral, black, elongated spots, sometimes broken into two portions, and then resembling a short, thick exclamation mark*. There is a diffuse, irregular, double black-brown dorsal band, enclosing on each segment an irregular, elongated, pale-blue dash, which is more or less spindle-shaped, and ending in a point before reaching each suture. The clear, pale-blue sides of the body are also speckled with fine black dots.

Also in the last (!) stage the short, irregular, sienna or deep ochreous brown lines in the dorsal black bands become obsolete.

It differs from the eastern *C. sylvatica* in the dorsal median spots being pale blue; in the obsolete, ochreous, lateral lines, and in the much larger, lateral dark spots, while the entire side of each segment is pale blue, not gray below.

C. californica is in a more advanced larval stage than *C. sylvatica*, and should stand above it, the lateral black line disappearing, being broken up into spots, and the dorsal ochre lines being obsolete. It is thus a more specialized form. The larvæ eat sparingly on willow and aspen, living until July 15.

I received a bunch of eggs from Mr. Rieksecker, of Santa Clara, California, April 7. Some of the larvæ hatched on the journey east; they seemed unable to eat their way out. I assisted one by removing the uneaten rim, and as it came out the hairs were still moist and lay along the back; several (those arising from one wart) stuck together before it was able to extend the end of the body and to walk away. In four or five minutes the end of the body became extended, and it began to walk. The head and body are dull black; the hairs grayish white; the ochreous dorsal markings not yet to be seen.

The larvæ described below were received from Miss Morton, June 4. Do not eat willow, but feed on oak.

Stage II.—Length 10 mm. (after first molt). The body and head are of the same shape and proportions as in *C. americana* and *sylvatica*, but with the dorsal piliferous warts more distinct; a pair of dorsal warts on each segment, making two distinct rows, between which are two parallel broken, irregular, snuff-yellow, thread lines, beginning on the third thoracic and ending on the seventh abdominal segment. The body is dull

livid blackish, with a dull bluish tint. The sutures are smooth and shining; hairs reddish brown. The eighth segment is scarcely humped.

The duration of this stage was about 6-10 days, as it molted the second time June 10-14.

Stage III.—Length 14-15 mm. (after second molt). *The body is now distinctly deep blue and black; the two yellow-brown dorsal lines are still more broken up. On the side of each segment the blue contains a distinct longitudinal, somewhat pear-shaped black spot, preceded in front by a black dot, like a short, thick exclamation point. The hairs are distinctly snuff-brown. A dorsal median row of blue linear stripes, separated by the sutures.*

Remarks on Clisiocampa californica.—In two alcoholic, full-grown larvae, length 36-38 mm., which I collected near Virginia City, Montana, the distinguishing marks are the two irregular, wavy, parallel dorsal fine tawny red lines, which, in my alcoholic specimens, enclose a faint blue median stripe, one on each segment, so that I think my Montana “(?) *fragilis*” is only a variety of *C. californica*. (In the third stage, Mr. Bridgham’s figure of the Californian specimens, the median blue stripe is very distinct, becoming fainter in the fourth stage.) The parallel, tawny, reddish lines are very irregular, sending off short twigs and branches, and on the hinder edge of each segment there are short, broken, irregular, subdorsal, tawny-red lines. The body is unusually hairy, the dorsal hairs being tawny reddish. The body beneath is mottled and irregularly streaked with blackish and paler lines and marks.

In Stretch’s “(?) *fragilis*” the two blue spots on each side, and in my specimens, are merged into the blue of the side of the body, but in another example they are distinct, and in the alcoholic Montana examples they are wanting. I am, therefore, inclined to think that “(?) *fragilis*” is only a variety of *californica*.

In one alcoholic specimen from Montana, the two blue spots on the side are just as in “(?) *fragilis*.”

NOTES ON VARIATION AND ON A VARIETY OF CLISIOCAMPA CALIFORNICA.

The Californian species of *Clisiocampa* seem to vary more in the larval state than our two eastern species, probably on account of the greater variety of climate, especially *C. californica*, which occurs in Montana, Colorado, Southern Nevada, and in the lowlands of California, thus extending over a vast region whose physical geography is very much varied, while it has different food plants. It is not improbable that *C. constricta*, in which the hairs and sides of the body are somewhat alike, has been derived from *C. californica*.

In a blown larva loaned by Prof. J. J. Rivers, the following remark is written on the label: “Supposed to differ from *C. californica*.” It is probably only a variety, and allied to a blown larva labeled by Mr. Rivers “(?) *fragilis*,” and kindly lent me by him. The hairs, ochreous

above and gray on the sides, are just as in *C. californica* and "(?) *fragilis*," but the dorsal pale-blue lines are nearly obsolete, being, however, present, though narrow, on the second and third thoracic segments, and on abdominal segments 4-7. The dorsal ochreous-red lines are present in front, but obsolete on the posterior half of the body.

It is characterized by a narrow, distinct blue streak on the side of each abdominal segment, extending from the lateral pale-blue stripe up into the dark-brown subdorsal region. There is a minute blue dot in front of the much more distinct streak, and these two spots are the remnants of the two normal lateral pale-blue dots of *C. californica* and "(?) *fragilis*."

LARVA OF A CLISIOCAMPA NOT CALIFORNICA.

Received from Santa Rosa, Cal., from E. L. Ricksecker, April 20. The cast skin of the head of a larva of the first stage was found in the box.

Stage II.—Length, 3-4 mm. Head large, considerably wider than the body, including the first thoracic segment; black. Body dark, with a distinct, firm subdorsal and two lateral pale, snuff-yellow lines, the upper lateral one being the more wavy and thread-like. The subdorsal lines send in yellowish points or dilations along the sutures. A dorsal row of dull blue elongated spots, that on the second thoracic segment larger and shorter and broader than the others. The blue spots are wanting at the end of the body, the one on the eighth abdominal segment not so distinct as the others in front. The dorsal hairs are long and unequal, snuff-yellow brown; those low down on the side being gray, and uniformly shorter than those on the back.

LIFE HISTORY OF CLISIOCAMPA AMERICANA (Harris).

From a mass of eggs found on the apple at Providence, and several of which hatched April 14, one was seen, April 15, to make its way out of the egg. The hairs, immediately after the shell is broken open, stand up as erect and stiff as a few hours later, not being soft, flabby and matted together as often seen in hairy or spiny larvæ, such as the Attacinae.

A brood of larvæ in the second stage and 5 mm. long was noticed in the crotches of apple and wild cherry trees at Providence, April 26.

Larva, Stage I.—Described when from ten to twenty-four hours old. Length, 2-3 mm. Head moderately large, as wide as the second and third thoracic segments, shining black, with numerous long, uneven white hairs. The prothoracic segment is a little wider than the second and third and than the head, and the lateral piliferous tubercle projects so as to add to the appearance of the width of the segment. From this segment the body narrows very gradually backward to the end. The body is wholly dull black, clothed with white hairs which arise from minute but yet distinct rough warts. While the sutures are livid and the front edge of the prothoracic segment is also livid, I can see no traces of any other colored spots like those of *C. californica*.

Stage II.—Described May 13. Length, 4-5 mm. The body still decidedly tapers to the end, though now the head is no wider than the body, which is blackish, *with a blackish dorsal line not yet turned blue*; the sutures are brownish; the hairs long and rusty brownish. The piliferous prothoracic tubercles are now small and not conspicuous as they are in Stage III.

In some observed April 26 (length, 5 mm.), and belonging to an earlier brood, *the median dorsal black line was broken and on each side of each segment is a black blotch*. The dorsal hairs brownish, those on the side gray, and some of those on the back tawny.

In another set of larvæ, from the web on wild cherry, 5-6 mm. long, described May 5, and apparently at end of second stage, the head is not so wide as the body, and considerably narrower than the prothoracic segment. *There is no blue about the body*. The head and prothoracic segment are black. A distinct black dorsal line interrupted at the sutures. On each side is an obscure similar dark line, but more interrupted and the spaces between the sections longer; below each section on each segment is a large, conspicuous, black, longitudinal, irregular, oval spot, immediately below which is a wavy light line, and parallel to this is a similar light line, below which is a fringe of whitish hairs projecting from the body. The dorsal hairs are pale ash-gray, not distinctly tawny. Abdominal segments 8-10 black, without markings. Some of the larvæ are much paler than most of the lot examined.

Stage III.—Length, 7-8, becoming 9-10 mm. Described May 13. The body still tapers to the end. The lateral prothoracic tubercles are well marked, and there is a pair of small dorsal ones on each succeeding segment of the body, bearing the usually tawny hairs, those on the sides being white, with some black hairs. *A distinct blue dorsal stripe, beginning on the second thoracic segment and disappearing on the eighth abdominal segment*; it is of the same hue as in the full-fed larva, and bordered with a fine wrinkled white line. *There are two lateral white thread-lines*, the upper one the more distinct; towards the end of the stage these lines change to a blue. Between these two lines is a row of minute black warts. The larvæ when in this stage vary much in the distinctness of the dorsal median blue stripe. It molted May 20-22, the length of the stage being about seven days.

Stage IV.—Length, 13-14 mm. The blue line is as in the full-fed larva, *but the lateral, linear, upright blue lines, one on each side of each segment, have now appeared, and also the very irregular, short, thread-like blue and yellow lines on the top and sides of the body*. The lateral prothoracic tubercles are still pronounced. It molted June 5-6; the duration of the stage being about fourteen days. June 8, 9, 10, full-grown larvæ seen out of doors. June 14, they were spinning their cocoons. The season was two weeks late.

In specimens of this stage, 22 mm. in length (described May 24), the dorsal band is now continuous and firm, not broken, and pale blue. On

each side of the median line along the back are faint, thread-like, fine, short broken lines, only perceptible under a lens. Besides the continuous pale-blue dorsal line, the distinctive marks are the two darker blue spots, short and straight; the one in front longitudinal and at right angles to the other, which is transverse and more distinct because situated on a black field. The sides of the body are filled in with blue, containing some fine ochreous lines, especially on the upper edge of the blue area below the longitudinal blue mark. The ordinary spinulated hairs of *C. americana* are represented by Fig. 21.

A variety of the larva of Clisiocampa americana observed at Providence, June 5 and 6.—One full-grown larva has the white dorsal line twice as wide as usual, and broken up into a series of exclamation marks. The line is interrupted at the sutures and each stripe swells out at the posterior end into a knob, and on the sixth abdominal segment it is short, and succeeded by a large, round, white spot, while on the first abdominal segment the stripe is represented by two large round spots.

THE YOUNG LARVA OF GASTROPACHIA AMERICANA.

Found on an apple tree at Brunswick, Me., July 28.

Stage III (?).—Length, 17 mm. The head is rather small, about three-fourths as wide as the body, rounded but flattened in front, blue slate-gray, nearly concolorous with the body. The prothoracic segment is much broader than the head, with a very large and prominent pale clay-yellow or luteous lateral tubercle on each side, bearing numerous long gray hairs. The second and third thoracic segments each with two dark, flattened, button-like warts centred with grayish. The sutures at hinder edge of second and third thoracic segments respectively are stained with pale ochre-yellow or luteous, forming a transverse stripe which is partly visible when the worm is at rest, but revealed more distinctly when it is in motion. On each segment behind first thoracic are four dorsal piliferous warts, two most conspicuous on second and third, and others on the side; those on the abdominal segments four in number and arranged in a square. From the first yellowish transverse dorsal streak is a longitudinal subdorsal concolorous (yellowish) line, and below it a concolorous fine hair-line between two dark lines. The body is dull, livid, bluish slate-gray, mottled and finely spotted with blackish points and piliferous warts. Along the side of the body the lateral tubercle, one on each side of second and third thoracic segments, is large, but not so long and slender as that on the segment in front, but yet they are unusually large and well developed, and they are replaced on the abdominal segments by the large fleshy lappets, bearing long, dense, fine, gray hairs, which are directed downwards. There are as yet no traces of the dorsal tuft of flattened hairs present in the mature larva. On the eighth abdominal segment is a decided rounded hump bearing two black flattened warts, from which arise numerous fine black hairs. The dorsal hairs are in general black,

and about one-third as long as the body is thick. The thoracic and abdominal legs are slate-gray, of the same color as the body.

LIFE HISTORY OF *HETEROPACHA RILEYANA* (Harvey).

This caterpillar has been reared from the honey locust (*Gleditsia triacanthos*) by Mr. Pilate (*Papilio*, ii, 67), while Prof. G. H. French writes that he has also found it on that plant. In response to my request, Mr. W. N. Tallant, of Columbus, O., sent me early in August several young larvæ, at Brunswick, Me., where its food plant flourishes; and a year later he kindly sent me the eggs and larvæ of this interesting form. Regarding its habits he writes me as follows: "Eggs deposited May 15. We have two and probably three broods per year. Eggs generally laid in a cluster or in a row or rows of twenty to forty. In confinement they will be deposited on the leaves or branches, but in nature I think they are always deposited on the bark, at least I have never found them on the leaves." The eggs hatched during May 25 and 26, not all simultaneously, and the description was made from the freshly hatched individuals, those which had been out of the shell for about half a day not differing from one I saw creeping out of the egg.

Egg.—Length, 1.5 mm. Cylindrical, though but slightly longer than broad. The shell is of a peculiar bluish white, the surface not highly polished, and under a Tolles triplet (about 12–15 diameters) it is not seen to be pitted, but under a half-inch objective, small, faintly marked hexagonal areas can be seen which are quite irregular in shape and with a thickened or raised central area. The surface of the shell is of a peculiar porcelain texture and bluish white, with short, broad, curved, darker blue streaks.

Larva, Stage I.—Just hatched. Length, 3 mm. The head is large and about one-third wider than the middle of the body; it is broad, being a little wider in front of the middle than behind. It is of a pale horn color, with a broad dark median band extending from behind and ending at the apex of the clypeus, where it spreads out somewhat, stopping at the transverse pale band crossing the head, and which dilates at the end on each side of the head. On each side of the dark band is a parallel pale band which passes down to the middle of the front, and then curves outward at a right angle, dilating at the end.

The side of the head is blackish, or rather the white portion leaves a large, much curved black band. The head is clothed with long, rather thick blackish and gray hairs.

The body gradually tapers backwards from the broad prothoracic segment which flares outward and upward in front. The segment is pale horn color above, rather naked. On each side is a piliferous tubercle, which is slightly larger than those on the succeeding segments, but not so well developed and prominent as usual in the group; at first pale, it afterwards turns darker, and it bears mixed dark and gray hairs, more

numerous than those on the succeeding segments. A broad median dorsal band, enclosing a fine, narrow, more or less interrupted dorsal dark line. On top of the second and third thoracic segments is a broken transverse fine black line, and on the same situation on each of the first eight abdominal segments are four minute square black dots, sometimes coalescing to form two transverse lines. A broad lateral (almost subdorsal) black band, consisting of a dark rounded oval patch, on each segment enclosing a minute pale piliferous wart. Below this and on the under side the body is pale livid flesh color, including the thoracic and abdominal legs. The hairs in general are short, rather evenly and closely cropped, and the dorsal ones of quite uniform length, not so long as the body is thick and mostly black, while the lateral ones are gray and spread straight out as usual in the group, touching, or nearly so, the surface the larva rests on; they are much more unequal in length than the dorsal ones. The anal legs are large and long, rather slender, spreading wide apart.

Stage II.—Length, 9 mm. All molted June 1. The head is now scarcely wider than the body, which is now dull blackish brown. The markings are nearly as before, the two parallel whitish lines turning out at right angles opposite the apex of the clypeus, which is now white, and the front of the head beyond the eyes is whitish. The head is hairy, with dense gray hairs in front. The body still tapers towards the end, and is now dull black-brown striped with eight fine whitish lines; of these the two dorsal ones are very faint, while the single subdorsal line is distinct, and in one or two, a day after molting, already stained with reddish ochreous; below are two parallel lateral whitish lines, the lower of which is wrinkled. On the eighth and ninth abdominal segments the two subdorsal lines are broken up into two dots on each segment. All the legs, both thoracic and abdominal, are dark brown. Many of the short dorsal hairs are black, those on the sides of the body longer and gray, as before. The lateral prothoracic tubercles are well marked, a little larger than those behind. In this stage nearly all the characteristic markings and colors are assumed.

Stage III.—June 4, 5, 6, 7, different ones molting on each of these days. Length, 12 mm. Head brown, with the whitish markings more *distinct than before*. The markings (spots and lines) are *decidedly brighter and more conspicuous than before*; and the body behind the prothoracic segment is *rust red ochreous above*. Prothoracic segment dark brown, with two yellowish triangular dots or notches on the outside of the dark dorsal tubercles. Behind this segment the dorsal, median, ochreous, rust-reddish band is distinct. The two subdorsal lines enclosing or forming the band are fine and distinct *ochreous rust-reddish and yellow, and they include on each segment a pair of long, somewhat wavy black stripes*, which are connected on the second and third thoracic segments, but separated by the sutures on the abdominal segments, so that there is a pair to each of these segments. The sides of the body are dark leaden brown, with two distinct lateral lines, and sometimes the lower broken whitish line is wanting. The

essential markings of the full-fed larva are now assumed. The clypeus is dark in the centre, white on the apex and edges. The whitish gray hairs are conspicuous and nearly conceal the thoracic and abdominal legs. The two dorsal yellowish dots on abdominal segments 8 and 9 are now conspicuous. The larvæ feed more or less concealed under and among the leaves in the breeding box, and this habit persists throughout the larval life.

Stage IV.—June 15-16. Most of them had molted June 16.

Stage II (?).—Summer brood. Length, 4.5-5 mm. Described August 6. The head is moderately large, considerably wider than the body, which tapers gradually to the end. The head is densely covered with long slender pale hairs of the color of the head, which, like the body and legs, is a greenish yellow-brown or pale snuff color. It is not easily to be seen while resting on the green leaf stalk of its food plant. The head is broad, full and rounded, with a median longitudinal dark-brown band, ending in front in a darker spot; the head on each side is brown, sending a point forward towards the middle of the head, and a brown band along the side of the head to the ocelli, from which another brown band extends across in front to the side of the clypeus, which separates it from its fellow on the other side.

The piliferous warts are minute, low, bearing several short, fine hairs, so that the body is quite hirsute. The lateral prothoracic tubercles, instead of being, as usual in the Lasiocampians, large and prominent, are in this larva scarcely larger than the others on the body. There is a faint dorsal median brown line. There is a subdorsal row of thoracic and abdominal piliferous tubercles, darker than the others; also a broader, darker lateral row of spots, each surrounding a broad, flat, dark, piliferous wart, connecting with the lateral dark band on the head. Below this is a narrower, paler lateral spiracular line, enclosing the pale, inconspicuous spiracles. The anal legs are broad and large, spreading widely. Both the thoracic and abdominal legs are concolorous with the body, and are densely hairy.

In another larva, 7 mm. in length and better fed, with the body filled out, the head was no wider than the body, as in the other, but the bands and spots, especially the dorsal and subdorsal ones, were more distinct than before. The subdorsal tubercles are flattened and enclosed in large, oblong, dark, longitudinal spots. The spiracular line is broad and more distinct, and below it, directly above the base of the legs, is a series of dark gibbosities.

In a third larva of about the same age and size, the body is more reddish than in the others.

Stage III.—August 16-20, summer brood. Length, 17 mm. The head is narrower than the body, dull slate-brown, like the brown portions of the body. On each side of the vertex are two parallel, dull ochreous brown stripes, soon becoming distinctly yellow, and opposite the apex of the clypeus turning outward at right angles and following a

sinuous course, and ending on the side of the head. There is a V-shaped yellow patch on the clypeus, which also sends an obscure yellowish line outward, in a course parallel to the line above. The labrum is pale; the face very hairy, as is the whole head. The body is dull, dark manganese or iron-brown. There is a dorsal, obscure, median, irregular, reddish-brown line; also two dull-yellow, narrow lines on each side of the body, the upper one of the two being the subdorsal one, and more or less stained with reddish. *There is an obscure, broken, yellowish line along the base of the legs below the dark spiracles.* The prothoracic segment is slightly swollen on the sides. The dorsal hairs are short and fine, but along the lower part of the face, and along the side of each thoracic and abdominal segment, is a swelling from which arise dense, long, pale-gray hairs directed downwards, much as in *Gastropacha*. The thoracic and anal legs are dark livid, and the body beneath is livid. The surface of the skin in general is rough and rather dull in color.

Stage IV.—Molted August 25 and described a few hours after. In the larva of the previous stage the left (?) anal leg was injured and shorter than the other; this defect was retained after this and the last molt.

Length, at first, 17 mm. The head is now larger in proportion than before, being a little wider than the body; it is somewhat bluish brown, with the markings as before, but much more distinct; the two parallel lines on the vertex not so diffuse and reddish as before, but nearly black, and each enclosing a lanceolate-oval, distinct, fleshy, whitish spot of the same color as the two sets of transverse, sinuous lines below. The face below is pale carneous; and on the sides and in front more densely hairy than above.

The body is of the same shape as before, still tapering to the end. Along the body extends a dorsal, reddish-brown, diffuse line as before, but a new system of markings appears in this stage, consisting of a set of four small light dots, two on each side of the dorsal median line. The prothoracic shield is now very distinct and concolorous with the head, and the segment is slightly wider than those succeeding, while the lateral, prothoracic, piliferous warts are still small. The subdorsal stripe is concolorous with the single dorsal one, but the lateral and infraspicular line at the base of the legs are now more yellow; otherwise the body in general is dark brown as before. On the end of the seventh and eighth abdominal segments are two pale-yellowish spots, and on the base of the suranal plates are two dark-yellow spots; the surface of the plate itself is concolorous with the prothoracic shield. All the legs are dark. The hairs low down along the side of the body are whitish gray, dense and depressed, partly concealing the legs, especially the middle abdominal ones.

Stage V and Last.—Molted September 4. Described September 12. Length, 32 mm. The head is as before. There is now visible, when the larva creeps, what had not been noticed in the preceding stages, *viz.*, a

bright, transverse, deep-orange, irregular band in the sutures between the second and third thoracic and the third thoracic and first abdominal segments. In the middle of each band is a black dot situated in the median line of the body. When the larva is at rest and the segments contracted, these two conspicuous stripes are not visible. They are evidently warning or danger signals, like the showy, bright band of *Gastropacha americana*.

The anterior corners of the prothoracic segment are dull orange-brown, the segment itself being dull dark-brown, with no lines. The median dorsal rather bright tawny-brown stripe begins most distinctly on the first abdominal segment, and extends uninterruptedly to the base of the suranal plate. The subdorsal lines, one on each side, are brighter ochreous orange, but are broken up, not only at the sutures, but by the transverse wrinkles, of which there are usually about five to each abdominal segment. The subdorsal lines or stripes are interrupted at the hinder end of each segment, next to the suture, by an irregular, squarish, light, tawny, ash patch, those on abdominal segments 7 and 8 being much paler and more distinct than the others in front.

The lateral supraspiracular line is narrower than the subdorsal stripe, less ochreous, with a little more pale yellow in it; it is irregular and broken, contains short, wavy, blackish lines and isolated dots, and dilates a little at the hinder end of each segment, forming a linear, light, pale, obscure yellowish spot opposite the light spots in the subdorsal stripe. Spiracles distinct, dull carneous, surrounded by a blackish-brown ring. An infraspicular indistinct, wavy, narrow, tawny-yellowish, much-broken line, most distinct under the spiracles. Still below this obscure line the lateral ridge, which is quite broken, is marked with two obscure tawny-reddish, vertical slashes on each segment; one is single, and the other is slightly V-shaped, the apex pointing upwards. The suranal plate is ornamented in front by the end of the dorsal tawny or Scotch-snuff brown band, broadly edged with ochreous yellow, the rest of the plate being black-brown.

The anal legs are dark-brown, with no markings; the middle abdominal legs are spread out laterally a good deal, so as to show from above almost their whole length; the legs themselves are, at base, livid lilac-brown, the plantæ pale livid, with a black chitinous streak on each side; these peculiar black chitinous pieces are narrow triangular, with the slender very acute apex pointing upwards, and are distinctly visible from above. The dense hairs arise from the longitudinal folds of skin situated over the abdominal and thoracic legs and corresponding situations on the other segments.

THE YOUNG LARVA OF ARTACE RUBRIPALPIS (Feld). (A. PUNCTISTRIGA (Walk.).)

A batch of eggs was kindly sent me by Prof. Roland Thaxter, from Cullowhee, N. C., early in July, the larvæ hatching July 9. The larvæ

were fed with oak, maple, raspberry, willow, poplar, hazel, rose, sumach and fir leaves, but they did not eat them. On being taken up, the freshly hatched larvæ spun a thread by which they let themselves down.

Egg.—Round, with the surface granulated; of a dirty white, clouded with reddish brown. They are laid separately in an irregular bunch.

Larva directly after Hatching.—(Fig. 22.) Length, 3 mm. The head is large, as wide as the prothoracic segment, dark brown, with two transversely oval light-gray spots above; along the front edge of the epieranium is a broad gray stripe, and at the base of the labrum is a transverse less distinct pale band.

The prothoracic segment is very large, slightly wider than the head, and from this segment the body tapers to the end. On each side of the prothoracic segment, and projecting outwards, is a large piliferous amber-colored tubercle, which is three times as large as those behind it on the succeeding segments. Between these are two minute dorsal piliferous tubercles. On each side of the second and third thoracic segments is a

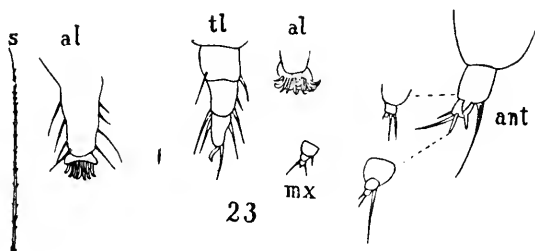

lateral amber-colored piliferous tubercle, while the dorsal tubercles between are rather larger than the lateral ones. On the abdominal segments the dorsal tubercles are amber-colored, becoming dark on the terminal segments, while the lateral tubercles are dark, concolorous with the body. The hairs are gray and dusky, those on the large lateral tubercles the longest and curved forwards in front of the head. Behind these the longest hairs are a little longer than the body is thick. The body is dark. On the abdominal segments the dorsal tubercles are amber-colored, becoming dark on the terminal segments, while the lateral tubercles are dark, concolorous with the body. The hairs are gray and dusky, those on the large lateral tubercles the longest, and curved forward in front of the head. Behind these the longest hairs are a little longer than the body is thick. The abdominal legs are long and slender, spreading outward beyond the body. The eighth pair of dorsal abdominal tubercles are a little larger than the others.

In general appearance, viz., the large, broad, first thoracic segment, the body tapering backward from it, and the large prominent lateral piliferous warts, one on each side of the segment, this larva is a true *Lasiocampid*,

with its characters rather more exaggerated than in *Clisiocampa*, and perhaps much as in *Gastropacha*.

Some details of the freshly hatched larva are represented in Fig. 23. *ant*, antenna; *mx*, maxilla; *tl*, a thoracic leg; *al*, an abdominal leg, showing the planta and crotchets; *al'*, another leg; *s*, a spinulate seta. (Author del.)

EXPLANATION OF THE PLATES.

PLATE V.

- Fig. 1. *Dryocampa rubicunda*. Larva in Stage II. The line under the figure should be nearly one-half longer. Bridgham del.
 2. *Sphingicampa bicolor*. Armature, Stage I. For explanation of details and of lettering, see the text.

PLATE VI.

- Fig. 3. *Eacles imperialis*. Armature, Stage I.
 4. *Eacles imperialis*. Armature, later stages.

PLATE VII.

- Fig. 5. *Citheronia regalis*. Armature, Stage I.
 6. *Hyperchiria io*. A freshly hatched larva, showing the eversible glands (*g*), etc.
 7. *Hyperchiria io*. Armature of the three thoracic segments, Stage I.

PLATE VIII.

- Fig. 8. *Hyperchiria io*. Armature of the last thoracic and abdominal segments, 1, 2, 6-10, Stage I.
 9. *Hyperchiria io*. Armature of the sixth abdominal segment, Stage II.
 10. *Hyperchiria io*. Spinulated dorsal tubercles of each thoracic segment, final stage.

PLATE IX.

- Fig. 11. *Hyperchiria io*. Eversible gland, with the adjoining spiracle, *sp*.; *g'*, a gland enlarged.
 12. *Hyperchiria*, sp. from Mexico. Armature of final stage; dorsal tubercle of each thoracic and of the seventh abdominal segment.
 13. *Hemileuca artemis*. Spinulated dorsal tubercles of each thoracic segment, final stage.

PLATE X.

- Fig. 14. *Hemileuca yavapai*. Spinulated dorsal tubercles of each thoracic segment, final stage.
15. *Gastropacha quercifolia*. Scales from dorsal tuft on second thoracic segment of the mature larva.
16. *Gastropacha quercifolia*. Flattened hairs from the lateral tuft of the second thoracic segment of the larva.
17. *Gastropacha americana*. Flattened hairs from the lateral tuft on eighth abdominal segment of the mature larva.

PLATE XI.

- Fig. 18. *Gastropacha americana*. Flattened hairs from the lateral tuft on second and third thoracic segments.
19. *Heteropacha rileyana*. Flattened hairs from the lateral tuft on the second thoracic segment of the mature larva.
20. *Acronycta hastulifera*. Flattened hairs.
21. *Clisiocampa americana*. Normal hairs, densely spinulated.
22. *Artace rubripalpis*. Freshly hatched larva. Bridgham del.

Note.—All the figures, except 1 and 22, were drawn by the author with the camera.

Energy as a Factor in Organic Evolution.

By John A. Ryder.

(*Read before the American Philosophical Society, April 7, 1893.*)

The fact that the energy developed by living bodies is correlated with cosmical energy is now a recognized canon of physiology. To give the proper emphasis to the part played by the energy developed within organisms, as a factor in the development of their own forms or *morphogeny*, is the purpose of the present paper. To define exactly the kinds of energy displayed and the mode in which its effects are produced in particular cases is another part of the subject to be dealt with. The definition of these subjects renders necessary the introduction of a few new terms, in order to avoid awkward circumlocution, to achieve brevity or directness of expression, and to eliminate the risk of indefiniteness in the use of words.

Hæckel very felicitously proposed the term *phylogeny* to express the fact that a certain tendency directed the drift or trend of development of a being along a line parallel with that of the series of forms ancestral to it. The being in the course of its development briefly recapitulated that of the ancestral series to which it belonged. This, in substance, is the famous fundamental *biogenetic law* first suggested by F. Müller.

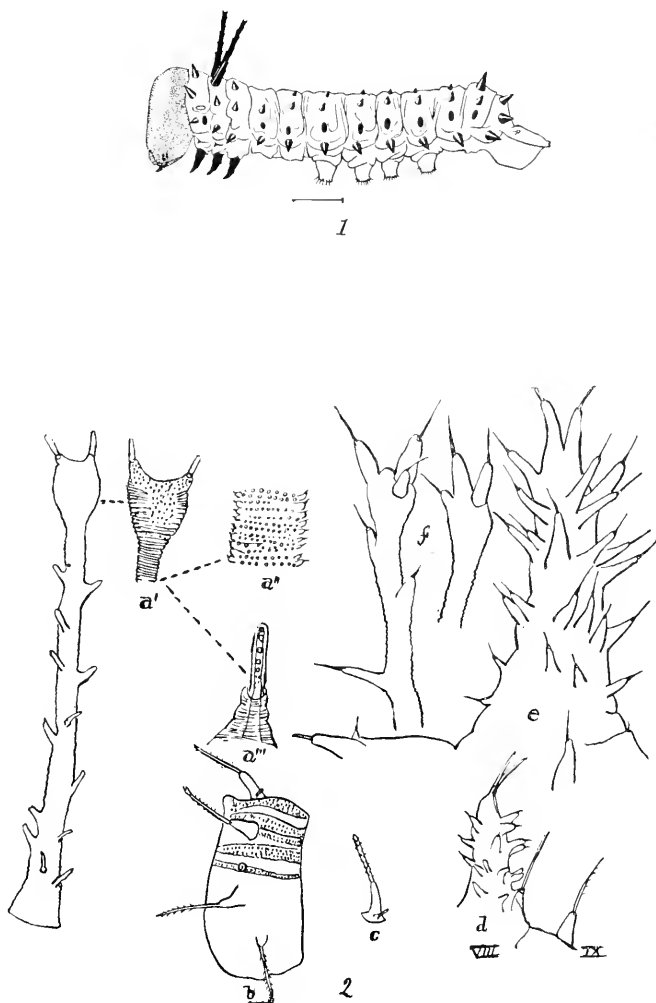

YOUNG LARVA OF *DRYOCAMPA* AND ARMATURE OF *SPHINGICAMPA*.

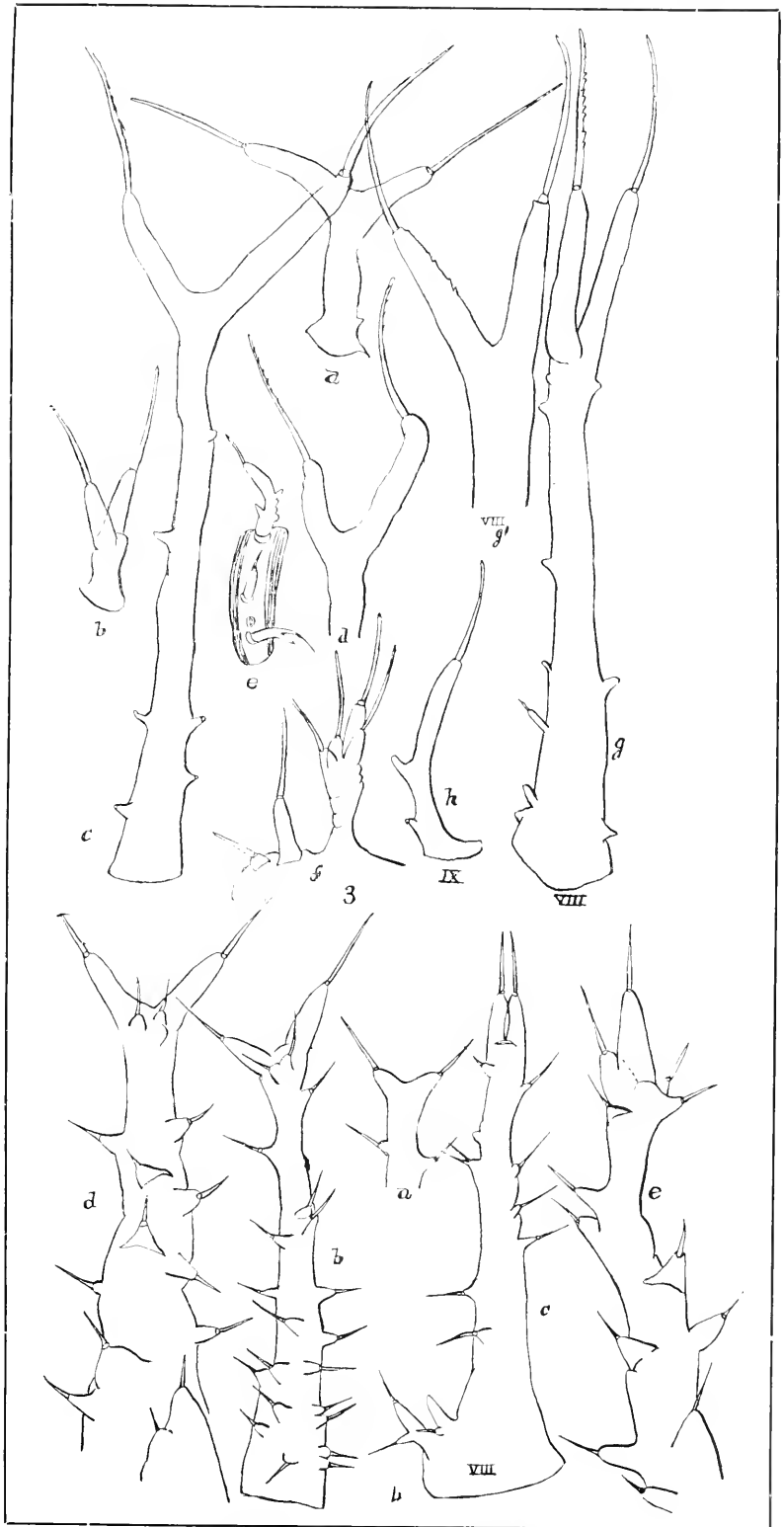

ARMATURE OF *EAGLES IMPERIALIS*.

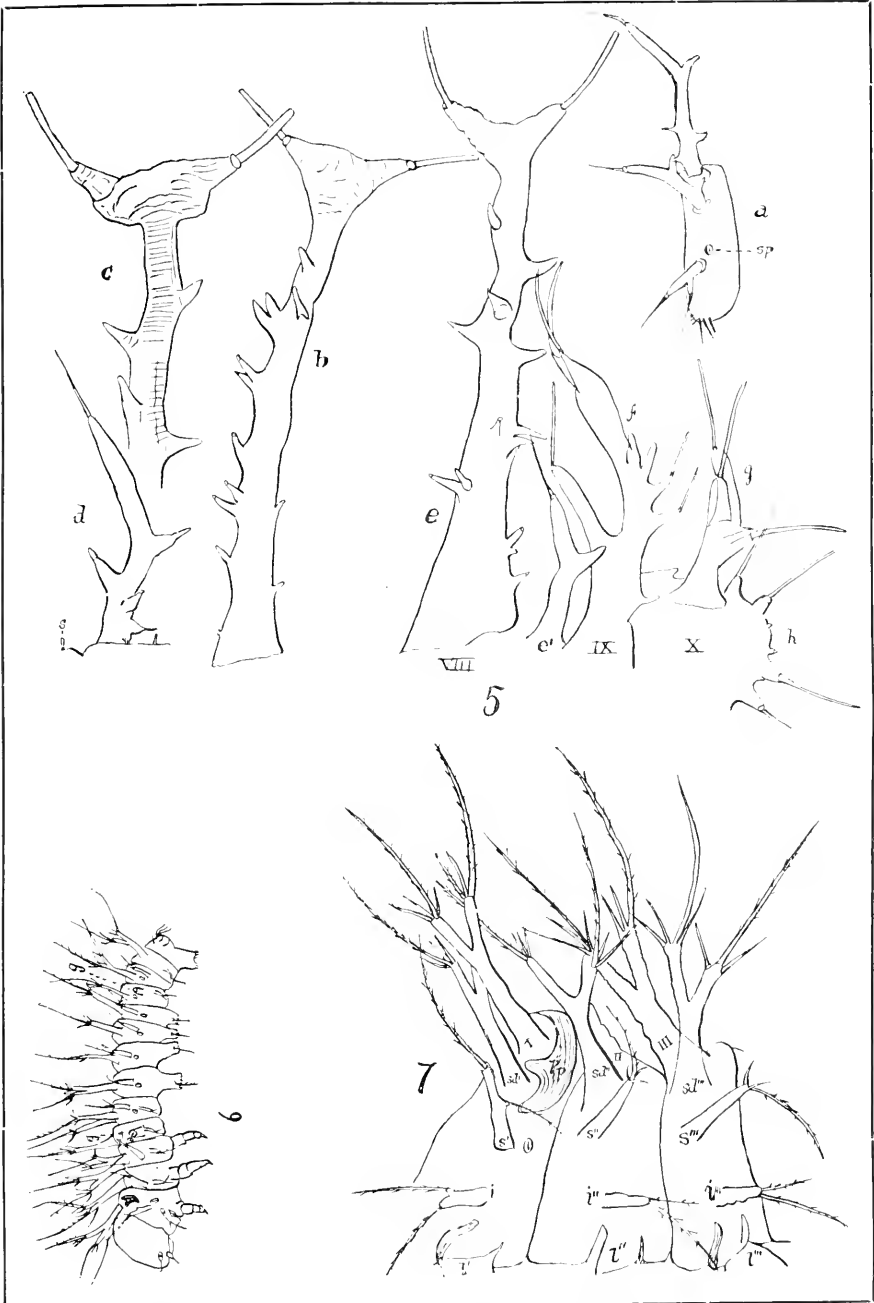

ARMATURE OF CITHERONIA REGALIS AND OF HYPERCHIRIA IO.

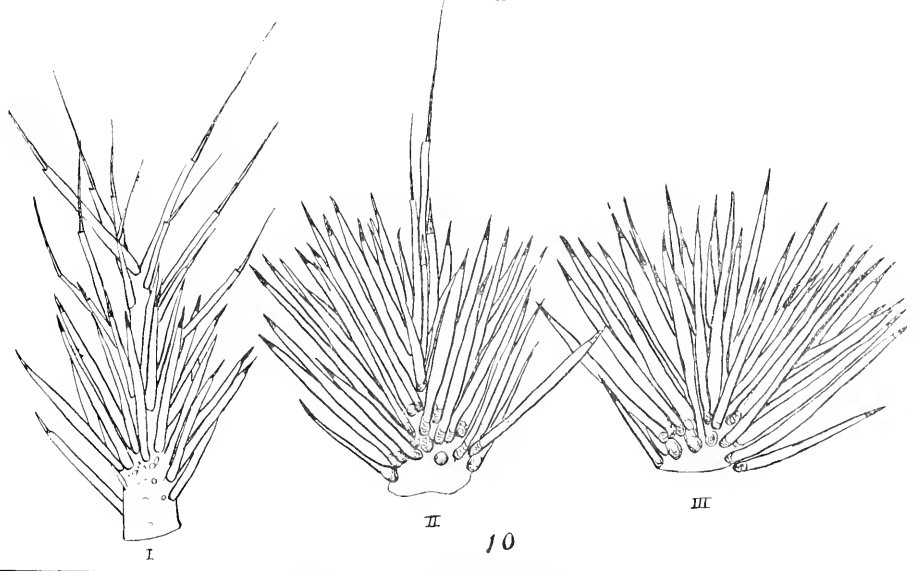
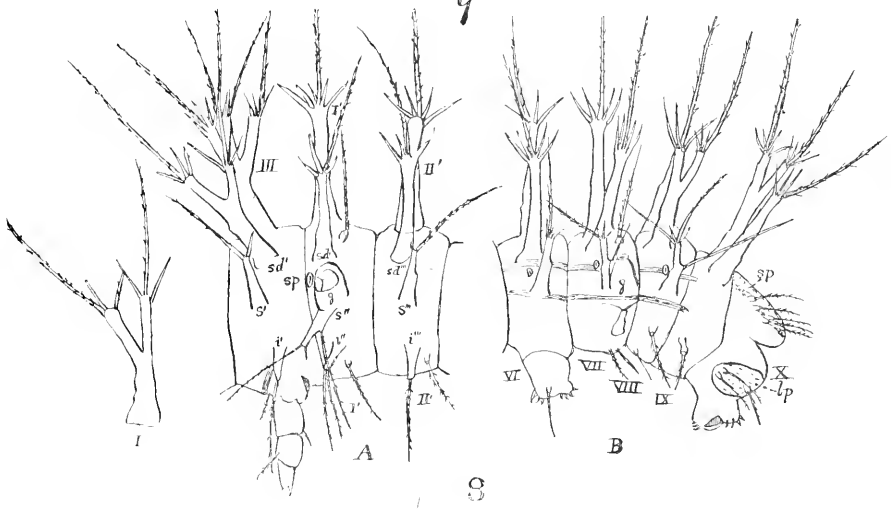
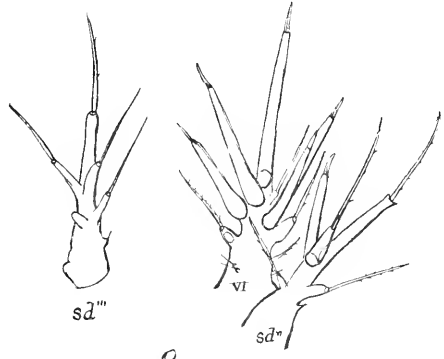

ARMATURE OF HYPERCHIRIA 10.



ARMATURE OF HEMILEUCA AND OF HYPERCHIRIA.

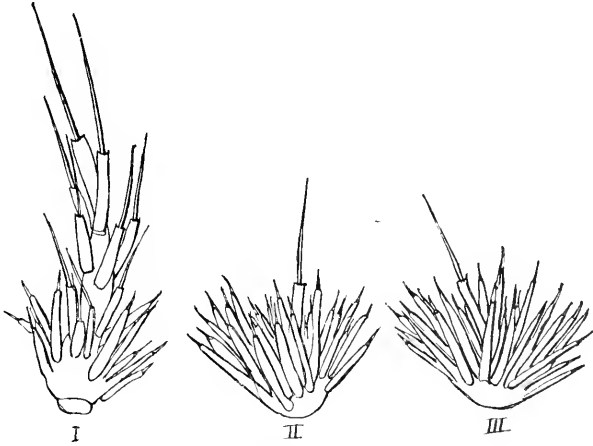

14

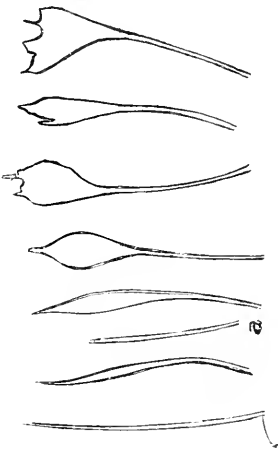
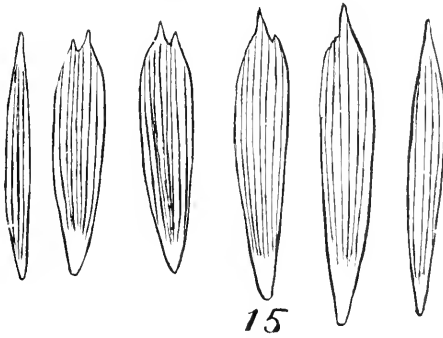

16

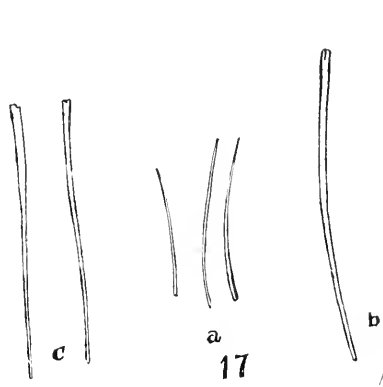

17

ARMATURE OF HEMILEUCA YAVAPAI AND SCALES OF GASTROPACHIA.

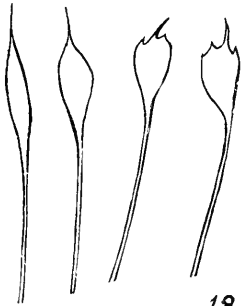

18



19

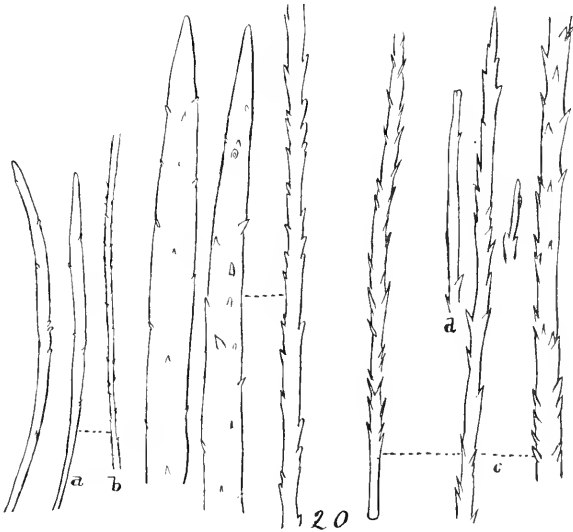

20

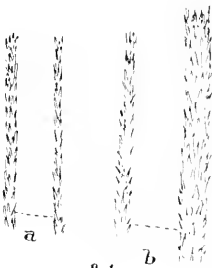

21



22

FLATTENED HAIRS OF CATERpillARS, AND (22) LARVA OF ARTACE.

Hæckel also proposed for the process of the development of the individual the term *ontogeny*, genesis of the individual being. The displays of energy, in time and space, controlling the process of development, both racial and individual, that is, the *phylogenetic* and *ontogenetic* processes, are now admitted on all hands to run more or less closely parallel. When old characters tend to reappear very early in *ontogeny*, it is explained that this is a case of reversion, atavism or *palingeny*. If, on the other hand, a new character tends to appear very late in the ontogeny, it is explained that it is because such a feature was late in appearing in the phylogenetic or racial history, it is therefore said to have arisen from comparatively recent variations of the type form, or to be *cænogenetic*. The registration upon the germinal matter of organisms of these developmental tendencies to reappear in a certain sequence and relation, in time and space, comprehends what is generally understood by the term *heredity*.

Hereditary phenomena are therefore *ontogenetic*, and in so far as the latter repeat an ancestral history they are *phylogenetic*. That is, the energies of individual development reflect or epitomize in the sequences and relations of their display those which have attended the evolution of the race.

Thus far the use of these terms, which have become current and well understood in biological literature, seems to be justified, in that they stand for a formula which is so largely true in spite of occasional discrepant facts that we must accept these words as brief or shorthand expressions for two great biological principles.

Adaptation of the organism to its conditions of life is now, as it always has been, a very difficult subject. Some have supposed it to be due to variation of the potentiality of the germinal matter derived from the two sexes, or to *Amphimixis*, and that the individual variations thus produced that were unfitted for survival were eliminated by natural selection. Others have maintained that there is more or less evidence of the occurrence of direct adaptation or adjustment of the organism to its surroundings with accompanying variation, and that consequently the energies developed within and without the organism had to do with the process of adaptation and the origin of variations. The development of adaptations was, therefore, according to this latter view, a resultant consequent upon the interaction of two sets of forces, namely, those developed within and also those developed without the organism. Natural selection in this case was also supposed to be operative as the agent eliminating the unfit. Weismann, Lankester and others have defended the first view. Hæckel, Cope, Spencer and even Huxley (the latter with some reserve, perhaps) have supported the latter opinion. Darwin himself was inclined to the last to ascribe a certain influence to external agencies, and also to use and disuse, in doing which he showed his leaning towards what has since his death been regarded as the more distinctly Lamarckian view of the origin of variations.

Prof. Cope has sought to establish a recognition of the factor of energy

as developed in the motions of organisms and their parts as an agency in the modification of the forms and proportions of their hard parts. In this he has distinctly followed Lamarek, Spencer and the writer, and to this agency he has applied the term *kinetogenesis*, which may also be written *kinetogeny* in order to make its Anglican spelling conform to that of the very useful terms proposed by Hæckel.

Unfortunately this term, *kinetogeny*, does not embrace a consideration of all the forms of energy that concern the problem of adaptation. My only reason, therefore, for invading this field of terminology is that there appears to be a need for another term which shall be more comprehensive and which shall apply to all the forms of energy involved in a study of adaptive processes, namely, the potential or static and the actual or kinetic. This will embrace both the energy of rest or equilibrium and that of motion or lack of equilibrium. The most general term that can be used for this purpose seems to be *ergogeny*, the etymology of which is apparent. This general term, *ergogeny*, will include not only *kinetogeny*, but also its antithesis, *statogeny*.

If an organism suffers morphological modification in consequence of the display of the energy of motion, any modification thus caused would be developed kinetogenetically. If, on the other hand, an organism were modified in such a way that the energies developed by it were in a condition of statical equilibrium, and, moreover, if its specific form depended upon the maintenance of such a statical balance, then any formal modification thus caused and maintained would be developed *statogenetically*. If it is meant that energy has been concerned in producing a certain modification without specifying the kind of energy, such modification may be said to have been produced *ergogenetically*. Concrete illustrations will, however, be necessary in order to give a clear notion of the very real difference that exists between the two processes, namely, *kinetogeny* and *statogeny*, embraced under the still more general term of *ergogeny*.

If the motion of the developing parts of an organism condition their structural modification in a definite and precise way, as in the case of the development of vertebral centra, of the vertical rows of scales on fishes, or the fractures across the fin rays of certain fishes, as I have shown elsewhere,* then the effects so produced are developed ergogenetically. In that such effects are the result of the expenditure of energy in the form of motion they are also developed kinetogenetically.

If, on the other hand, the process is one in which the energy developed is a consequence of growth itself, and is dependent merely upon the gross physical and statical properties of the living matter itself, such as the varying surface-tension of different parts of the surface of the plasma, then the problem becomes one, not of motion, but of the want of motion, of forces in equilibrium or a statical one. Such conditions of statical equilibrium of surface-tensional forces of the adjacent surfaces of the cells of

* "Proofs of the Effects of Habitual Use in the Modification of Animal Organisms," *Proc. Amer. Philos. Soc.*, Vol. xxvi, Nov. 21, 1889.

the early stages of segmenting eggs are known by the thousand to the skilled embryologist.

In that these cannot at first be overmastered by either phylogenetic or ontogenetic forces, or by both combined, proves that the forms so developed are, therefore, the resultants of the energy represented by the phylogenetic and ontogenetic or the sum of the hereditary forces working in antagonism against a recurring statical condition of the substance of the germ. This statical condition reasserts itself at the close of every segmentation, so that there is a recurrent conflict between these two sets of forces at every step of development. In fact, the round or oval form of the egg is a statical condition of the germinal mass dependent wholly or partially upon its own surface-tensional properties. That this is gradually overcome in the course of the ontogenetic process is well known, but it is also a fact that no known form of animal or vegetable development is exempt from the influence of the interference of statical forces of equilibrium, mainly those of surface-tension. In so far, therefore, as the form of the early stages of the development of an embryo are thus interlarded with, such modifications are statogenetic. The great generality of this principle, therefore, becomes apparent. The generality of statogeny is, in fact, coextensive with that of phylogeny and ontogeny. But this is not all. Every statogenetic state alternates with a kinetogenetic state, since every new statogenetic condition is heralded by a kinetogenetic one. It is this incessant organic and organizing seesaw of processes that is comprehended under the still more general term of ergogeny.

Such must, therefore, be my excuse for adding this new set of terms to those already in use, since they represent a series of processes of such universality as to be of an importance second only to those of phylogeny and ontogeny. To illustrate in detail the great variety of phenomena with which ergogeny and its forms, kinetogeny and statogeny, have to deal would much transcend the purposes of this paper. Only sufficient additional examples will therefore be given to show the far-reaching character of these principles.

In the motion of *Amœba proteus*, kinetogenetic phenomena either alternate rhythmically with statogenetic phenomena, or perhaps more correctly, both constantly accompany one another in the course of the movements made by this very simple organism. The chemical processes within the Amœba by means of which its surface-tension is constantly being disturbed are kinetogenetic, since this equilibrium or statical balance of the plasma is thus recurrently overthrown. This leads to a temporary rupture of the surface layers of molecules and an intrusion of new molecules from within to repair the rent. When this is accomplished a statical equilibrium is temporarily restored only to be followed by a recurrence of motion or overthrow of statical equilibrium. This leads to the more or less fitful or interrupted motion seen in these organisms. These alternating and conflicting processes also determine the figure of the organism at every instant, so that ergogeny becomes, in the lowest forms, through its elementary

types of kinetogeny and statogeny, form-determining or morphogenetic. The development of the figure of the body of *Amœba proteus* is also partially conditioned by cohesion to adjacent surfaces, and is also, to some extent, pulled upon as a semifluid mass by gravity and flattened. The vortical flux of its own particles through themselves also elongates it in the direction of its own motion. This causes the anterior end of the organism to present a tense, rounded outline, while its posterior end is wrinkled, papilliform or uneven. The vortical flux of particles in the centre of the body of the organism flow fastest while they gradually move slower towards the surface where the ultimate and outermost layer is at rest. Thus in every detail of its morphology do we discover that *Amœba* is absolutely the creature of energy conditions. Its shape at every instant of its existence is determined ergogenetically as we may speak of the form-conferring forces developed from within as distinguished from those of gravity, adhesion and cohesion that are operative from without. Even the ideally perfect form of vortex motion of the particles of its substance is disturbed and distorted by the interaction of this complex set of forces. Moreover, since the physical properties of the different species of *Amœboids* are very different, their kinetogenetic and statogenetic characteristics differ correspondingly, so that their behaviors are very different for this reason. The profound differences of form presented by their pseudopodia are to be partially accounted for on this ground, and partially on the ground of the differing physical constitution of their substance.

The phenomena of motion of plasma or cells may be generally comprehended under the term *cytokinetic*, their statical conditions under the term *cytostatic*. In the same way the active and resting stages of nuclei may be regarded as *karyokinetic* and *karyostatic*. The motion and rest of the centrosomes of cells may be named as their *astrokinetic* and *astrostatic* conditions. These six terms, one of which is already in use, are proposed in order to connect the phenomena of cell division with ergogeny in general. The origin of the motion of the *Amœba* is to be sought in its own plasma; it is therefore cytokinetic. The alternating periods of quiescence of *Amœba* are cytostatic; its spherical form in the encysted condition is the result of a perfect cytostatic equilibrium in every direction. These results are also ergogenetic; that is, the changes of configuration due to motion are kinetogenetic; those due to a condition of temporary statical equilibrium are statogenetic.

Osmotic processes in combination with surface tension and reciprocal pressures developed against adjacent structures develop the most manifold changes of configuration. If osmotic pressure is the same in every direction within a cell or a mass of cells, a spherical figure results such as that of *Volvox*. If, on the other hand, the equal internal pressures are antagonized from without by unequal pressures at different points corresponding modifications of figure are developed. This is illustrated in the most manifold ways in the cells of plants and animals. Such modifications thus caused are largely statogenetic.

If motions of hard parts upon each other tend to alter or deform the modeling of the surface in a particular way, as seems to have been the case with teeth, the process is kinetogenetic. If the basal part of the conical surface of a pointed tooth have its enamel organ folded under constraint during growth in a conical matrix into which it expands by growth more rapidly at its basal region than the walls of this matrix expand, the result is partly kinetogenetic and partly statogenetic.

If the development of a blastoderm be conditioned by surface and interfacial tension in such wise as to cause it to conform to the configuration of double curvature of the yolk mass upon which it extends itself, the result is mainly statogenetic. If an embryo be pressed down into the blastoderm as the result of constraint from above during its growth, and the surrounding non-embryonic area is thus caused to be reflected over it more and more as growth of both embryo and blastoderm go on, an amnion is developed. This process is kinetogenetic so far as the growth and reflection of the blastoderm is concerned, but statogenetic in so far as the permanent molding and retention of the figure of the amniotic cavity is concerned. If fin-rays are fractured or segmented in a regular fashion and in response to the exigencies of the motions of the fin, such a result is kinetogenetic. If the calcifiable matrix developed about a notochordal axis be regularly segmented at points alternating with the intervals between the myotomes by the agency of the motions to which such an axis is subjected during use, the result is again kinetogenetic. If an originally globular egg be distorted into an ovoidal body within a tubular oviduct due to circular pressure, as happens in birds and insects, the result is almost purely statogenetic. An empirical mathematical formula may therefore be written for every variation in the shape of the common hen's egg for a curve which shall account also for its shape.

If, as in the case of the double monsters developed in meroblastic eggs due to karyokinetic disturbances, there is a strong interfacial tensional attraction between the germ and yolk substance, it is impossible to shake the first blastomeres apart as in the case of holoblastic eggs, so that fused embryos or monsters only can be produced from such meroblastic ova. Such a result is statogenetic, that is, statical conditions in the meroblastic egg so far override the ontogenetic processes that fused monsters only are here possible, whereas in holoblastic ova in which the blastomeres can be completely separated two or more distinct embryos can be produced from what had begun its development as a single embryo.

So universal is this interference of the statical conditions of the plasma of segmenting ova with the ontogenetic processes, that not a single metazoan organism can be named the development of which is not thus marred in some way or other. It is often a long time relatively after development has begun that there is any obvious delineation of the embryo. In fact, this cannot take place until the statical energies of surface-tension which have kept the egg globular are overridden. In so far as the ontogeny of any organism is marred by statical conditions of energy-display, its em-

bryonic form is also modified. In so far as such statical interference affects the figure of the organism they are morphogenetic or form-determining. In so far the figure of a developing being is disturbed or modified by statical agencies its figure may be said to be subject to statogenetic influences. No existing larval form has escaped the influence upon its own shape of a constantly active statical equilibrium of its own substance. There is, therefore, a constant struggle going on during development between the phylogenetic and ontogenetic forces, determining the sequence and relations of the successive cleavages of the egg and the statical equilibria that obtain amongst its several parts. Statogenetic processes are, therefore, as constant and universal as the phylogenetic and ontogenetic. One may even go so far as to say that possibly the relations thus tending to be established by statical conditions may tend to become transmissible as hereditary tendencies. Such indeed is the view upheld by Prof. E. B. Wilson in his remarkable paper on "The Cell-lineage of Nereis."* I have myself seen no less than three consecutive recurrences of the same statical conditions in a fish egg, none of which can, for this reason, be definitely proved to be purely ontogenetic.

The faceted eyes of insects are usually hexagonal, but not invariably so. I have found triangular, quadrangular and hexagonal facets in the eyes of *Tachinus*. Now these different forms are due to disturbances of the statical conditions obtaining between the individual ommatidia during growth of the eye. If the pressure is the same from every direction laterally during growth, a cylindrical eye would result. If the lateral pressure is the same from six points at equal distances apart around each eye, the regular hexagon will result; should any two opposite pairs of the six pressures be less than the pressures from the other two pairs irregularities in the hexagons will appear. If cylinders are grouped so that the side of every one touched the sides of six others, which may be done by bringing their tops into rows in three directions, and if now each cylinder be increased in diameter, there will be pressure developed in six directions diverging at equal angles of 60° from one another, a hexagonal configuration of the ends of the cylinders would ultimately result, provided they were formed of plastic material. The same thing sometimes happens when a plastic and nearly homogeneous mass cools and contracts, when cracks appear in the mass generally dividing it into pentagonal and hexagonal prisms, as happened in case of the cooling of intruded mass of molten basalt in the Giant's Causeway in Ireland. A series of cylinders arranged so that every one shall touch six others is also most economical of space, and in the processes of growth is the natural result of a statical equilibrium due to equal pressure from six directions in a plane. If a series of cylinders be brought into rows in two directions only, and so as to touch their neighbors at only four points, quadrangular columns would result were the diameter of every cylinder increased against four others, provided all were composed of plastic material. In these ways have the

* *Journ. Morphology*, Vol. vi.

various forms of the facets of the compound eyes of insects arisen. So too the reciprocal marginal interference of the growth at six equidistant points of the scutes of such forms as the extinct *Glyptodonts*, has developed in such scutes a hexagonal configuration. In these cases growth is the kinetogenetic factor, and the statogenetic factor is the struggle to bring about an equilibrium of marginal pressures during growth, as a consequence of which a hexagonal figure results.

The development of a cylindrical form of the body is also a case where an equilibrium is concerned that is largely statical in character. The tense condition of its fluid-containing cavities, such as the alimentary canal, will confer upon such an organ a cylindrical configuration; so also in the case of blood vessels. It is indeed probable that the very form of the blood corpuscles or disks is discoidal in virtue of a statical equilibrium of their substance within the fluid plasma in which they are immersed, and that there is a double vortical flux of the substance of these disks from the centre to the periphery on both faces, or the reverse. This vortical flux is probably maintained by the exigencies of metabolism and calls for the incessant exhibition of a tendency towards a condition of statical equilibrium. In this way we may conceive that the thousands of millions of red blood disks coursing through our vessels are enabled to not only maintain their flattened configurations, but to also thus greatly increase the areas of their surfaces and be thus rendered more efficient agents in the processes of oxidation and deoxidation. Here is a statical condition, as we may suppose, that has been adaptively developed through the direct expenditure of energy, by the matter of the corpuscle itself. In other words, our red blood corpuscles have, in the first place, and with the utmost probability, acquired their present configuration ergogenetically. If this is true in the case of the blood disks of ourselves, it is probably also true of the blood disks of all other forms.

The globular form of the egg is a statically developed condition, so is that of the more or less nearly globular morula and also of the blastula; but in the latter internal osmotic pressure is also a factor. Even the brain shows in its earliest form the tendency to develop as vesicles under statical conditions. Here its growth is the kinetogenetic factor, and the tendency for the hemispheres to be at first globular vesicles is owing to the statical influence of the substance composing their walls. Later, as these vesicles grow, they press upon each other along the median line when they present a flattened aspect towards one another from the operation of the same causes, and we at last have developed the "hemispheres" of anatomists. In this way it results that a single somewhat globular body is formed, made up of two halves. Under constraint within the membranous cranial walls the latter conform to this pressure of the growing brain-globe within and conform to its shape, so that a somewhat globular cranium results. Following in detail the evolution of the fissures of the brain, even these are developed kinetogenetically through growth; the pallium or cortex under restraint within the skull grows and shows a tendency to

have its wall folded into ridges, with intervening fissures that tend, for assignable mechanical laws, to join one another at an angle of 120° , as first pointed out by the late Dr. A. J. Parker, and, as it seems to me, correctly attributed by him in part to ergogenetic influences. It may also be shown that the heart, in the course of its development, gives evidence of being subject to the morphogenetic influence of ergogeny.

The spiral or torsional form of many of the articular faces of the ends of bones in the limbs of terrestrial vertebrates can probably be shown to be associated with the development of torsional stress in locomotion. That such torsional stress is actually developed during the locomotion of terrestrial vertebrates has been conclusively proved by Prof. Allen from a careful study of the work of Muybridge upon animal locomotion. Upon every hand, therefore, there is evidence of structure that has been developed in conformity with the conditions of the expenditure of animal energy. I have myself called attention to the fact that digital reduction first began in the hind limbs or in those subjected to the greatest stress, in leaping, by land vertebrates. The forelimbs show this tendency later and in conformity with the fact that they cannot become the channel for the dissipation of such large amounts of energy, impulsively, as the hind ones. Digital reduction and specialization is therefore to be regarded as having been induced and begun ergogenetically.

In the course of other work I have had occasion to call attention to the fact that the foundations of the skeleton were in every case laid down in certain comparatively inactive, or, as I have elsewhere expressed it, ametabolic tracts. These tracts were either external, protective non-plasmic envelopes or they were developed between the organs. In both cases they tend to take the form of intercellular or circumcellular matrices, or as matrices laid down between organs. Metabolism is *nil* in them everywhere because of the non-plasmic and the non-metabolic character of their substance. Such matrices, therefore, present from the lowest protozoa up to the highest metazoa tolerance of inert foreign matters within their substance. Such matrices being colloid, they often attract inert calcareous or silicious matters that are held in solution in the circulating fluids as deposits, just as such deposits are seized and held under laboratory and non-vital conditions by colloids in the presence of hypersaturated solutions. In other words, there is here a tendency to revert to a statical condition on the part of these inert salts, which thus tend to crystallize within such a matrix and within the living body. These matrices are thrown out as a protection, or as the result of irritation of cell tracts, or to increase the volume of an organism; the colloids of which they are composed attract the inert calcareous or silicious salts that pass through the living and adjacent plasma and a statical equilibrium is thus restored. The skeletal matrix thus calcifies, as we express it, whereas the truth is that we are probably dealing with a phenomenon that differs but little in its essential nature from one that may be imitated in the laboratory. The process is one that ultimately develops a statical equilibrium when the

matrix is saturated with inert silicious or calcareous materials. This may be especially well shown in regard to the wonderfully complex shells of Radiolarians, Foraminifera, the spicules and skeletons of sponges, the shells of the eggs of birds, the calcification of bone and cartilage, etc. I therefore very much question whether there is a single skeletal structure anywhere to be met with, the development of which does not take place in some measure statogenetically. Especially is this true of the configuration of the skeletons of such complex objects as Radiolarians, Foraminifera, etc., where surface tension coöperating with the process of the gradual statogenetic saturation of the matrix gives to them their wonderful complexity and beauty. While such phenomena as those of the genesis of the heterocercal or upwardly deflected condition of the axis in the tails of fishes, or the downwardly deflected condition of the axis in Ichthyosauri are almost purely kinetogenetic, the multiplicity of factors concerned, statogenetic as well as ontogenetic and phylogenetic, must always be considered and each given its due weight and importance in achieving the morphogenetic result. That there is an absolute conflict between statogeny and kinetogeny on the one hand, and of phylogeny and ontogeny on the other, in the case of the development of the ova of multicellular forms admits of no doubt. All metazoa pass through larval stages in which the statical condition of equilibrium of the plasma of the egg is gradually, in a great measure, overridden by the hereditary energies represented by phylogeny and ontogeny. That there still remain traces of the effects of kinetogeny and statogeny in the adult organism cannot be denied in view of the facts to be derived from the shapes of tissue elements, and even of organs, as the foregoing paragraphs show.

These few observations and reflections will, I think, at least make it clear that the terms *ergogeny*, and its forms of *kinetogeny* and *statogeny*, are justified, and that they stand for what constitutes a very important part of the machinery of organic evolution, the generality and importance of the influence of which is certainly not less than second to that of phylogeny and ontogeny. The energy factor or *ergogeny* left entirely out of consideration must therefore seriously cripple the symmetry and completeness of any general theory of organic evolution.

APPENDIX.

The introductory chapters to Hæckel's great work on the Radiolaria, forming part of the series of *Challenger Reports*, contains much that is suggestive in relation to the subject of this paper. Also papers by Dreyer and others in the *Jenaische Zeitschrift*, in reference to the ergogenetically developed forms of the tests of Radiolarians, Rhizopods and Foraminifera. The botanists have long since appreciated the importance of this subject, and Berthold's *Protoplasmechanik* is an especially suggestive work. Sachs has also contributed to the subject. Much that is suggestive is also to be found in the *Principles of Biology* of Herbert Spencer, though his facts

are not invariably to be depended upon, owing to the very different interpretations now to be given many of them. Papers by Cope on the mechanical development of the structure of the hard parts, teeth and joints, are to be found in the *American Naturalist*, *Journal of Morphology* and *Proc. Amer. Philos. Soc.* Prof. Hyatt has also published several important papers on this subject, especially in reference to Molluska. Suggestive papers have also been published in this connection by Dr. W. H. Dall, while Lang has considered the development of the shells of univalve mollusks from a mechano-physiological standpoint in his *Lehrbuch d. Vergleichenden Anatomie*.

Purely physical papers by Plateau, Mensbrugghe, Quincke and others are also important as well as the experimental and biological results published by O. Bütschli and H. Virchow.

The subjoined list of papers by the author of the foregoing paper embraces the principal part of what he has published upon the ergogenetic development of morphological characters in the animal kingdom :

On the Laws of Digital Reduction, *Am. Naturalist*, 1877, pp. 603-607.

Nature, xvii, 1877, p. 128.

On the Mechanical Genesis of Tooth-forms, *Proc. Acad. Nat. Sciences*, Philadelphia, 1878, pp. 45-80 (Abstr. by C. N. Peirce).

Dental Cosmos, xx, 1878, pp. 465-472.

Further Notes on the Mechanical Genesis of Tooth-forms, *Proc. Acad. Nat. Sciences*, Philadelphia, 1879, pp. 47-51. Review of by E. D. Cope, *Am. Naturalist*, 1879, pp. 446-449.

On the Origin of Bilateral Symmetry and the Numerous Segments of the Soft Rays of Fishes, *Am. Naturalist*, xiii, 1879, pp. 41-43.

The Gigantic Extinct Armadilloes and Their Peculiarities, With a Restoration, *Pop. Sci. Monthly*, xiii, pp. 139-145. 4 figs. [Discusses the mechanical genesis, degeneration, and coalescence of vertebral centra.]

The Significance of the Diameters of the Incisors of Rodents, *Proc. Acad. Nat. Sciences*, Philadelphia, 1877, pp. 314-318.

On the Position of the Yolk-blastopore as Determined by the Size of the Vitellus, *Am. Naturalist*, 1885, pp. 411-415.

On the Availability of Embryological Characters in the Classification of the Chordata, *Am. Naturalist*, 1885, pp. 815-819 and 903-907.

On the Genesis of the Extra Terminal Phalanges in the Cetacea, *Am. Naturalist*, 1885, pp. 1013-1016.

An Outline of a Theory of the Development of the Unpaired Fins of Fishes, *Am. Naturalist*, 1885, pp. 90-97.

The Origin of the Amnion, *Am. Naturalist*, 1886, pp. 179-185.

On the Origin of Heterocercy, etc., *Ann. Rep. U. S. Com. of Fish and Fisheries for 1884*, pp. 981-1085, Pl. ix, 1886.

A Theory of the Origin of Placental Types, etc., *Am. Naturalist*, 1887, pp. 780-784.

On the Homologies and Early History of the Limbs of Vertebrates, *Proc. Acad. Nat. Sciences*, Philadelphia, 1887, pp. 344-386.

On the Development of the Cetacea, etc., Ann. Rep. U. S. Com. of Fish and Fisheries for 1885, pp. 427-485, Pl. iii, 1887.

A Physiological Theory of the Calcification of the Skeleton, Proc. Am. Philos. Society, xxvi, 1889, p. 9.

The Polar Differentiation of Volvox, etc., Am. Naturalist, 1889, pp. 218-221.

The Quadrate Placenta of *Sciurus hudsonius*, Am. Naturalist, 1889, pp. 271-274.

The Origin of Sex, etc., Proc. Am. Philos. Society, xxviii, 1890, pp. 109-159.

The Placentation of the Hedgehog and Phylogeny of the Placenta, Am. Naturalist, 1890, pp. 376-378.

A Geometrical Representation of the Relative Intensity of the Conflict Between Organisms, Am. Naturalist, 1892, pp. 923-929.

On the Mechanical Genesis of the Scales of Fishes, Proc. Acad. Nat. Sciences, Philadelphia, 1892, pp. 219-224.

The Principle of the Conservation of Energy in Biological Evolution; A Reclamation and Critique, Proc. Acad. Nat. Sciences, Philadelphia, 1892, pp. 455-468.

The Inheritance of Modifications Due to Disturbances of the Early Stages of Development, Especially in the Japanese Domesticated Races of Gold-carp, Proc. Acad. Nat. Sciences, Philadelphia, 1893, pp. 75-94.

The Mechanical Genesis of the Form of the Fowl's Egg.

By John A. Ryder.

(Read before the American Philosophical Society, April 21, 1893.)

The configuration of the outline of the hen's egg is determined apparently by mechanical means while the egg-membranes and shell are in process of formation within the oviduct.

The conditions, after the passage of the ovum or yolk proper into the oviduct, seem to be about as follows :

1. In the upper part of the oviduct the albumen is laid down upon the yolk by the activity of the albumen-secreting structures forming the wall of the duct. This albumen is laid down in successive layers, as is proved by the structure of the albumen and chalazæ, when these are coagulated by heat and then cut into thin sections. This lamination of the albumen is a result of the mechanical relations that the yolk sustains to the surrounding albumen-secreting surfaces, and this structure of the albumen is mechanically caused. The chalazæ are produced as the first deposits of albumen in the oviduct behind and in advance of the yolk. The twisting of the chalazæ is mechanically caused for the reason that the twist of the chalazæ

at opposite poles of the yolk is in opposite directions. This could not occur except under conditions of rotation of the yolk or true egg during the early steps of its passage down the oviduct. The laminae of the chazae are in a continuous spiral scroll such as is developed by a thin lamina rolled upon itself, such as a scroll of paper. This would seem to prove that a rotation of the forming egg was necessary in order to give rise to the phenomena described.

2. The membrana putaminis is deposited in the lower portion of the oviduct. Its fibres are cemented together where they cross one another, showing that they must be formed in a plastic condition. The putaminis, moreover, is laminated, showing that, like the yolk, it is a secretion, the laminae of which are deposited in succession. It finally covers the entire egg and albumen as a secondary egg envelope, and possesses certain characteristic traits of figure, firmness and elasticity.

3. From the beginning of the process of the development of the secondary egg envelopes in the oviduct there is circular constraint around the yolk and albumen owing to the tubular shape of the oviduct itself. The walls of the latter, press upon the contained egg somewhat after the manner of a broad elastic girdle. This pressure around the egg elongates the whole mass in the direction of the long axis of the oviduct. If this pressure of the elastic walls of the oviduct were not associated with peristalsis of the oviduct, in other words, were the forming egg to remain at rest within the duct, it would be deformed only from a spherical to an elliptical figure. This restraint is least at the ends of the mass where it tends to be extended into the lumen of the duct. This elastic annular compression of the forming egg within the oviduct may be regarded as the true cause of the deformation of the hen's egg towards a stable elliptical configuration, while still in the plastic state.

4. After the completion of the membrana putaminis a third homogeneous layer is deposited upon the latter in which the shell is formed. This shelly deposit consists at first of isolated circular nodules of calcareous matter, that only become fused together at a late stage of their deposition; when in fact they commence to become crowded against one another and pressed into close contact as they enlarge from within outward. Previous to this fusion the shell is flexible, if an egg is prematurely laid with an imperfect shell, as every farmer's boy knows. After the fusion of these minute calcareous plates the shell becomes rigid, as seen in a fully matured egg. It is probable that a certain differential of pressure has been maintained at opposite ends of the egg during the formation of the membrana putaminis, the matrix of the shell, and the shell itself that is instrumental in giving to the hen's egg and birds' eggs in general their particular forms. This differential of pressure at opposite sides of the elastic girdle formed round the egg by the oviduct is caused by the physiological necessity of propelling the egg down the oviduct, or, in other words, is due to the fact that the egg is moved along by forces developed within the wall of the oviduct itself. As this differential of pressure increases on one of the sides of the oviductal

girdle round the egg will the form of the latter depart more and more widely from the figure of a true ellipse and become more and more ovoidal or egg-shaped.

The problem of the development of the figure of the hen's egg is one that may be very easily dealt with mathematically. In fact, judging from the great variety of variations of form presented by eggs it is probable that a different equation would be required for every case, thus showing that the forces operative in the process were themselves variable, a result which is *a priori* most probable. The pressure preventing the passage of the elliptical mass down through an elastic tube must be developed

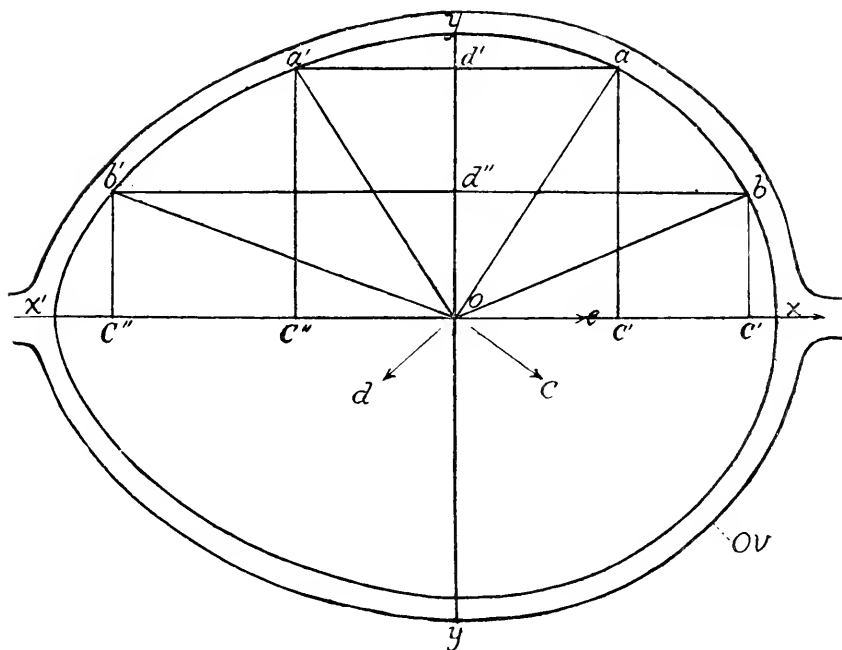

largely in the form of friction, and the resistance of the walls of the oviduct to dilation. To overcome this a greater pressure must be exerted on the elliptical egg-mass at a point above its minor axis than below the latter. This will tend to squeeze part of its substance, since it is at last enclosed in an elastic capsule before shell formation takes place, into the lower or larger end of the mass. In this way the ovoidal form of the egg seems to have first arisen. The mechanism by which this is accomplished can, however, be best understood by means of a diagram showing the manner and conditions under which the forces involved cooperate.

If the wall of the oviduct ov is supposed to conform to the shape of

the egg and to be closed in front and behind it, in a longitudinal section of the egg in place in the oviduct, we should obtain a diagram* somewhat like the foregoing. The major axis of the egg coincides with x , which produced is also coincident with the closed lumen of the oviduct. The minor axis y is transverse to the oviduct. If it is sought to move the egg within the oviduct, dilated as it is, at the point where the egg lies, a certain propulsive force must be developed annularly by the circular fibres in the wall of the duct. This requires that the force exerted from x' to y shall be greater than that exerted from x to y , else the egg will not be moved along x in the direction of e . This implies that the annular muscular coat in the wall of the oviduct shall contract with greater energy from x' to y than from x to y , but as a matter of fact the egg is not elliptical so that the major axis x is cut into unequal parts, $x' o$ and $o x$ by the axis y . Since this true, if the annular muscular coat of Oe be of the same thickness throughout its length by the very conditions which now obtain in respect of the statical equilibrium of the figure of the egg, it would, upon the simultaneous contraction of those parts of the wall of the oviduct in contact with it, be impelled down the latter, or in the direction of e . We stated above, however, that so long as the egg contents were not confined to a rigid envelope and were at rest within the duct that the figure of equilibrium would be an elliptical one through the long axis x of the mass. Now this is just what does not happen and we can only seek the cause for such a departure from the elliptical figure in the added propelling force which must be applied at one side of y in order that the mass may be moved at all. If the fluid mass is not rigid the very application of the greater force on one side of y will cause the elliptical figure of the longitudinal section of the mass at rest to pass into an ovoidal one the instant the mass is put into motion. This simple statement of the facts as to the conditions which obtain will make it self-evident that the force which causes an egg to become ovoidal within the oviduct is developed as a differential of force manifested between two immediately adjacent annular segments of the duct and on opposite sides of y .

The geometrical demonstration of this fact is so simple that it will present no difficulty to any one familiar with the rules of elementary geometry. It two lines $a' a$ and $b' b$ be drawn parallel to x through y , so as to touch at either end the outline of the semicircumference of the egg and ordinates be then erected, as $a c'$ and $b c'$ and $a' c''$ and $b' c''$, four rectangles will be formed which will completely exhibit the quantitative antagonism of the forces developed symmetrically upon either side of y or of x . The two rectangles, $a' d' c'' o$ and $b' d'' c'' o$ are greater in area than the rectangles $a d' c' o$ and $b d'' c' o$ on the other side of y . The sum of the diagonals $a' o$ and $b' o$ of the first pair to the left is greater than that of $a o$ and $b o$ of the second pair to the right of y , therefore the sum of the former as representing the propelling energy developed by the pressure

* This diagram has been constructed from the outline of a hen's egg very carefully plotted. It therefore represents an actual contour.

of the oviduct from x' to y must be greater than the sum of the first pair representing the resistance developed by the walls of the oviduct from y to x . It is this difference of annular pressure thus developed between x' and y along the curve and y and x along the remainder of the same curve that is responsible not only for the energy which propels the egg along the oviduct, but which also deforms it while in a plastic condition, before rigid membranes are deposited over it, and causes it to permanently assume the ovoidal figure so familiar to every one in the form of the hen's egg.

Pursuing the analysis further, the composition of forces developed from x' to y would take the direction c . Those from y to x would take the direction d . A similar set would be developed from the two inferior quadrants below x , but these we may neglect, since they are of the same value exactly as the pair of antagonistic energies already considered and developed above the axis x . Since $c > d$ the tendency will be for the mass to be propelled in the direction of e and there will thus be a second composition of antagonistic forces in the direction of e which will not only propel the egg along the oviduct, but also tend to deform the egg-mass prior to its becoming encased in a rigid egg-shell.

The development of the figure of the eggs of birds is therefore in all probability a purely dynamical problem or one in which energy is applied in a definite manner to the plastic surface of a mass in statical equilibrium within the oviduct. The moment motion is set up to propel the egg through the duct the forces operative in determining the figure of the as yet unformed shell depend upon the physiological activity and condition of tone of the muscular walls of the oviduct which must first deposit the membrana putaminis, the figure of which as a somewhat elastic closed membrane is determined as here supposed. This in turn definitely determines the figure of the shell, which is deposited upon it. In this way it can be shown that the interplay of energies developed by the soft parts or oviduct have determined the conformation of a hard part or of the shell.

The shell itself is, however, deposited by a process involving the development of a statical equilibrium which is finally satisfied when the development of the shell has been completed. What is meant here is that the shell-matrix is a non-cellular colloidal body which has a strong attraction for soluble, inert, earthy substances such as lime salts, circulating in the fluids of the body. These being particularly abundant, partly as excreta, in the vicinity of the cloaca, near which the shell of the eggs of birds is formed, the source of the supply of these matters is not far to seek. These soluble but inert salts are attracted by this colloidal matrix which they finally saturate when the shell may be said to be completed.

The shell of the eggs of birds has therefore probably been developed statogenetically, while the figure of the shell has been developed kinetogenetically. Both factors are, however, ergogenetic, that is, form and structure has here been developed by the expenditure of energy.

That there has been great variation in the mode of exhibition of the

kinetogenetic factor in the development of the shells of eggs is proved by the fact that the latter vary in form very widely. So much is this the case that a distinctly different algebraic formula would have to be worked out for every variation of the form and size of eggs laid by even the same bird. If the very slight disturbances of the counterpoise of the energies on either side of the axis y which condition and determine the figure of such a body as a hen's egg are sufficient to produce the remarkable variations which we may see by the thousand in any marketplace, how slight must be the disturbances of the interplay of the living energies that need to be set up in living bodies in order to produce the endless number of variations that they present. If the figure of the hen's egg is dependent upon the mode and condition of the equilibration of forces developed within an oviduct, what reason is there to doubt that plastic organisms are so modified, only in ways a thousand times more complex and difficult to unravel and explain.

The application of the principle here developed is very extensive. It applies also to an explanation of the oval and ovoidal forms of the eggs of many animals that are manifestly due to causes operating in much the same way. Those of many insects at once occur as a case in point. The elongated blastocysts of mammals growing under a condition of annular constraint within a tubular uterus or uterine tubule are other cases that illustrate the same doctrine. The foregoing discussion also clearly explains why it is that the blunt end of the hen's egg comes down the oviduct as its foremost portion and not the sharp end, as one would be led to suppose, were it not positively established that such is not the case.* It also makes it evident that variations in the figure of the eggs of birds are due to the exhibition of varying quantities of energy and to different conditions of activity of the walls of the oviduct during the formation of the secondary egg envelopes, in the thus protracted process of oviposition.

One may be further permitted to surmise that in its nearly completed state in the oviduct that the prolonged and at first voluntary retention of the egg in the latter by the parent distinctly tended to cause the deposit of the third and last homogeneous matrix into which calcareous infiltration occurred automatically as suggested above. The retention of the egg in the oviduct caused it to act as an irritant when a second and last basement membrane, the matrix of the future shell, was thrown down in the oviduct comparable to that of the basement membrane or zona deposited around the ovum as the vitelline membrane in the ovarian follicle. The evolution of the eggshell itself may, therefore, with the utmost show of probability, be traced to a voluntary and more or less intelligent desire of the female parent to protect its potential offspring for a time within her own body. In carrying out this protective instinct which preceded the habit of nest-building, concealment or burial of the whole laying was resorted to, as still practiced by reptiles, such as alligators and turtles. The entire brood or nestful were also at first laid at once and concealed, and a

* The evidence for this was first adduced by Nathusius, *Zoolog. Anzeiger*, Vol. viii.

crude egg-burrow only, without subsequent parental care, as in the case of *Pityophis*, was constructed. We can thus understand that the often elaborate and intelligent nest-building habits of Aves were preceded by the far cruder and hastier and simpler nesting habits of the Reptilia, which, on account of the phylogenetic relations between the two groups, should, on *a priori* grounds, be the case.

The origin of the egg-shell of the eggs of birds and reptiles may therefore be traced to physiological causes acting automatically under the control of those instincts or intelligent efforts at self-preservation and protection extended by the parent to the young even while still in the form of the outwardly and apparently quiescent condition of the egg. The prolonged retention of the eggs in the oviducts must have begun in reptiles where the whole laying of a season is found to occupy the oviducts at one time. Such prolonged retention would distinctly tend to develop a shell owing to the operation of agencies that we can in a great measure trace and specify as above. Such a retention of the ova within the oviduct for a period would also distinctly tend to develop the amniote placental and viviparous forms of development, provided the retention of the eggs was from any cause prolonged. There is, in fact, much evidence to indicate that eggshells or secondary egg envelopes were, in the first place, evolved because of the prolonged retention of the eggs within the oviduct by the wary female for purposes of protection. Such a prolonged retention of the eggs in the oviduct was only the prelude to the evolution of placental viviparity and to the highest forms of parental care as exemplified in the human species. Both processes were, therefore, adaptive as they were also manifestly superposed in the order of their development. The mechanical genesis of the amnion was begun in fishes, and was completed amongst higher forms. Its conditions have been in part traced by the present writer and Dr. T. W. Shore. In the same way the successive steps of the evolution of the allantois may be traced. It may accordingly be shown that the lines of demarcation between egg-laying and viviparous vertebrates are in large measure arbitrary, and that if the evolution of these processes be carefully studied, direct and obvious connections can be established between both. Not only is this the fact, but there also now exist sufficient data to establish upon a tolerably firm foundation the doctrine that the various types of placentation are developed as the results of direct mechanical and physiological adaptation. The evidence for this appears quite as clear as that which has been adduced above in regard to the dynamical method and mechanical conditions under which the form of the eggshell is determined in the oviduct of birds.

Notes on the Classification and Taxonomy of the Testudinata.

By G. Baur, University of Chicago.

(Read before the American Philosophical Society, May 5, 1893.)

I. THE TYPE OF *HYDROMEDUSA TECTIFERA* Cope, WITH GENERAL OBSERVATIONS ON THE GENUS *HYDROMEDUSA* AND THE CLASSIFICATION OF THE PLEURODIRA.

Through the kindness of Prof. E. D. Cope, I have received for examination the type specimen of *Hydromedusa tectifera* Cope. The carapace is totally different from that figured by Boulenger* as *Hydromedusa tectifera*.

1. *Osteological Differences.*—In the diagnosis of *Hydromedusa* Boulenger states the number of neural bones as seven, and in the figure mentioned seven are shown. In the type specimen there are only six neural bones, allowing pleuralia 7 and 8 to meet in the middle line. The neurals are much more slender than in the specimen figured by Boulenger. The first neural is 39 mm. long and extends to the second pleural, excluding neurale 2 from pleurale 1. The first neural measures 6 mm. in front and 15 mm. behind. The second neural is only in connection with pleurale 2. The sixth neural bone is placed between the fifth and sixth pleuralia. The pleuralia 6 do not meet in the middle line, but are separated by the sixth neural and the seventh pleural of the right side, which touches the sixth pleural of the left. The first peripheral (marginal bone) is completely excluded from the second pleural; it is placed between the nuchal and the second peripheral. Notwithstanding the carapace measures over curve 29 cm. in length, it is not fully ossified; there are small fontanelles on the side between the pleurals and peripherals and also between the plastron and the peripherals.

2. *Differences in the Dermal Shields.*—The first vertebral shield is very much longer than broad (58 mm. : 31 mm.); where it meets the posterior cervical shield it is 32 mm. broad; the breadth of the posterior end of the second cervical shield is 68 mm. There cannot be any doubt that the specimen figured by Boulenger as *H. tectifera* belongs to a different species from the type. What name it ought to receive I am unable to determine.

Boulenger considers the specimen figured by Wagler† as *Hydromedusa maximiliani* and that figured by Peters‡ under the same name as identical species, which he also considers as *H. tectifera*.

There seems to be no doubt that the specimens figured by Peters and Wag-

* Boulenger, G. A., *Catalogue of the Chelonians*, London, 1889, p. 211.

† Wagler, Joh., *Natürliches System der Amphibien*, Pl. iii, Fig. 25-42, 1830.

‡ Peters, W., "Zur Osteologie der *Hydromedusa maximiliani*," *Müll. Archiv.*, 1839, pp. 280-289, Pl. xiv. I may mention here that this paper originally appeared as Peters' *Dissertatio Inauguralis*, under the title "Observationes ad Anatomiam Cheloniorum," with one plate (Berolini, 1838).

ler belong to two different species. This is at once seen from the structure of the squamosal and frontal.

In the specimen of Peters the posterior ends of the frontals are very slender and *not* connected with the very slender inner branches of the squamosals. In the specimen of Wagler the posterior ends of the frontals are well developed and *united* with the inner branches of the squamosals. There is a frontosquamosal arch in Wagler's specimen, but there is only a supraoccipito-squamosal arch in the specimen of Peters.

Unfortunately, the skull of the type of *Hydromedusa tectifera* Cope is not preserved, and it is therefore impossible to determine whether one of the specimens figured by Peters and Wagler belongs to this species. In spite of the papers of Dr. Günther and Boulenger on the subject, it is now again as undecided as ever. Further studies have to decide about it.

The characters of the genus Hydromedusa Wagler. The skull of *Hydromedusa* shows a peculiarity which separates it widely from its allied forms, *Chelys* and *Chelodina*. In *Hydromedusa* the posterior nasal openings are of enormous size and the *pterygoids* form their posterior and inner border. In other words, the palatines have no inner process at all to connect the vomer (Peters). This seems important enough to place *Hydromedusa* in a separate family, *Hydromedusidæ*, with the following characters :

Hydromedusidæ.

A slender parieto-squamosal-, or supraoccipito-squamosal arch. Posterior nasal openings bounded by maxillary, palate, pterygoid and vomer; frontals double; nasals free; premaxillary double.

I also propose to establish separate families for both *Chelys* and *Chelodina*, with the following characters :

Chelyidæ.

A strong parieto-squamosal arch. Posterior nasal openings bounded by maxillary, palate and vomer; frontals double, no free nasals; premaxillary single.

Chelodinidæ.

No parieto-squamosal arch nor supraoccipito-squamosal arch. Posterior nasal openings bounded by maxillary, palate and vomer; frontal single, nasals free; premaxillary double.*

The other genera of the *Chelyidæ*, in the sense of Boulenger, are :

Rhinemys † Wagler, 1830 = *Phrynops* Wagler, 1830 = *Hydraspis* (Blgr.)
+ *Rhinemys* (Blgr.).
Platemys Wagler, 1830.

* Baur, G., "The Pelvis of the Testudinata," *Journ. Morph.*, Vol. iv, 1891, p. 352.

† Baur, G., "Note on the Genera *Hydraspis* and *Rhinemys*," *Am. Nat.*, May, 1890, p. 485.

Emydura Bonaparte, 1836.*

Elseya (Gray part, 1867) Boulenger, 1889.

These I place all in one family which I call *Rhinemydidae*.

Rhinemydidae.

A slender or broad parieto-squamosal arch. Posterior nasal openings bounded by maxillary, palate and vomer; frontal double; nasals free; premaxillary double.

The Chelyidae, Chelodinidae, Rhinemydidae and Hydromedusidae form one natural group of the Pleurodira, which has been already established by me in 1887,† but without proper name. I propose to call it

CHELYOIDEA. ‡

Fifth and eighth cervical vertebrae biconvex; no mesoplastron; no quadratojugal; vomer present and complete.

The second group of the Pleurodira, which contains the families Pelomedusidae and Podoenemididae, may be called

PELOMEDUSOIDEA.

Second cervical biconvex; a mesoplastron; quadratojugal present; vomer rudimentary or absent.

Pelomedusidae.

Quadratojugal without connection with parietals.

Pelomedusa Wagl., *Sternothaurus* (Bell) Gray.

Podoenemididae.

Quadratojugal in connection with parietals.

Podoenemis Wagler; *Peltocephalus*, Dum. and Bibr.

Erymnochelys Baur. §

Intermediate Extinct Family Bothremydidae. ||

Vomer well developed; no free nasal bones; dentaries coössified; small mesoplastron present.

January 16, 1892.

* This genus was proposed by Bonaparte, in 1836, in his *Cheloniorum Tribula Analytica*, p. 7, and not in 1838, *Arch. f. Nat.*, i, p. 140, as stated by Boulenger.

† Baur, G., "Osteologische Notizen über Reptilien," Fortsetzung, ii, *Zool. Anz.*, No. 24, 1887, p. 101.

‡ In the *Zool. Anz.*, No. 285, 1888, I had given the names Amesoplastralia and Mesoplastralia to the two groups, among which I placed at this time several fossil forms which do not belong there.

§ Baur, G., "The Genera of the Podoenemididae," *Am. Nat.*, May, 1890, p. 483 (*Zool. Anz.*, No. 285, 1888; No. 290, 1888).

|| Baur, G., "Notes on Some Little Known American Fossil Tortoises," *Phil. Ac. Nat. Sci.*, 1891, p. 124.

II. NOTES ON SOME TYPES OF THE TESTUDINATA COLLECTED BY SPIX AND PRESERVED IN THE ZOÖLOGICAL MUSEUM AT MUNICH.

Rhinemys.—In my note on the genera Hydraspis and Rhinemys (*Am. Naturalist*, May, 1890), I have stated that the number of the neuralia in *Rhinemys rufipes* Spix, the type of Rhinemys, was not yet known. I have now examined the type specimen and have found that the number is seven. All the pleuralia 1-7 are separated by the neurals; the pleuralia 8 alone are in contact.

Emys erythrocephala Spix, 1824.

An examination of the type specimen shows that this species is identical with *Podocnemis unifilis* Troschel, 1848; the name *Podocnemis erythrocephala* has therefore to be used.

Emys amazonica Spix, 1824.

This species is nothing but the *Podocnemis sextuberculata* Cornalia and the *Bartlettia pitipii* Gray, and the name *Podocnemis amazonica* has to be used therefor. The skull shows so considerable differences from the other species of *Podocnemis* that it seems justified to accept Gray's generic term *Bartlettia* for this form.

The type specimen has six neuralia; in the specimen figured by Boulenger seven are present.

I have to state here that these facts were fully brought out already by the late Prof. v. Siebold. The labels written by him give Spix's original names and Troschel's and Gray's names are added respectively.

I am greatly indebted to Prof. R. Hertwig for the permittance to examine these interesting types and to Inspector Will for assistance given during the examination.

MÜNCHEN, August 1, 1892.

III. THE GENERA OF THE TRIONYCHIDÆ.

The generic name *Trionyx* was established by E. Geoffroy St. Hilaire in 1809* (or 1808†). Schweigger ‡ had introduced the name *Amyda* in a MS. handed to the French Institut in 1809.

Geoffroy mentions the following species:

Trionyx subplanus Geoffr.

“ *egyptiacus* Geoffr., *Testudo triunguis* Forskal.

“ *stellatus* Geoffr., *Testudo cartilaginea* Boddaert.

“ *carinatus* Geoffr., one of the American species.

* Geoffroy St. Hilaire, E., “Mémoire sur les Tortues molles, nouveau genre sous le nom de *Trionyx* et sur la formation des Carapaces.” *Ann. Mus. Paris*, xiv, 1809, pp. 1-20, Pl. 1-5

† Geoffroy St. Hilaire, E., “Sur les tortues molles,” *Paris Soc. Phil. Bull.*, i, 1808, pp. 363-367 (not seen).

‡ Schweigger, “Prodromus monographiæ Cheloniorum.” *Königsberger Archiv. für Naturw. and Math.*, Bd. i, Königsberg, 1812, pp. 271, 272.

- Trionyx javanicus* Geoffr., *Testudo cartilaginea* Boddaert.
 “ *coromandlicus* Geoffr., *Testudo punctata* Lacépède.
 “ *gergicus* Geoffr., *Testudo ferox* Schneider.
 “ *euphraticus* Geoffr., *Testudo euphratica* Daudin.

In 1830 Wagler* divided the genus *Trionyx* Geoffr. into two genera—*Trionyx* and *Aspidonectes*.

Aspidonectes is thus characterized: “Thorax cartilagine flexibili limbatus; digiti tres palmæ plantæque unguiculati;” and the following species are named: *Trionyx ægyptiacus* Geoffr., *Trionyx javanicus* Geoffr., *Testudo ferox* Penn., *Trionyx muticus* Les., *Trionyx carinatus* Geoffr.

Trionyx is characterized thus: “Thorax limbo osseo mobili auctus; digiti Aspidonectis;” and the single species *Testudo punctata* Lacép. is noted.

One year later, in 1831, Gray† divides also the genus *Trionyx* Geoffroy in two divisions—*Trionyx* and *Emyda*. Among *Trionyx* he names *T. ferox* Merr., *T. muticus* Les., *T. ægyptiacus* Geoffr., *T. indicus* Gray, *T. lurum* Gray, *T. javanicus* Geoffr., *T. subplanus* Geoffr., *T. euphraticus* Geoffr. Among *Emyda* he names *Trionyx* (*Emyda*) *punctata* Lacép.

The characters of *Trionyx* are: “The margin of the shields cartilaginous and the sternum narrow.” Those of *Emyda*: “Margin of the shield with a series of small bones in front and behind; limbs covered, when withdrawn, by the valves on the side of the sternum.”

It is evident that *Trionyx* Gray is the same as *Aspidonectes* Wagler, and *Emyda* Gray the same as *Trionyx* Wagler; the name *Emyda* Gray can therefore not be admitted. Besides the name *Emyda* had already been used by Rafinesque (*Analyse de la Nature*, Palerme, 1815, p. 75) for *Emys* Dum. A few months later Gray‡ published a “new edition” of his *Synopsis Reptilium*. He now separates *Emyda* completely as a distinct genus from *Trionyx*. Meanwhile he had seen Wagler’s paper, and he states in the Additions and Corrections, p. 78, “Dr. Wagler keeps the generic name of *Trionyx* for my *Emyda* and uses that of *Aspidonectes* for my *Trionyx*.”

In 1832, Bonaparte§ follows Wagler, using *Trionyx* and *Aspidonectes*.

In 1835, Duméril et Bibron|| propose the new names *Gymnopus* for *Aspidonectes* Wagler and *Cryptopus* for *Trionyx* Wagler, which, of course, cannot be accepted.

* Wagler, Dr. Joh., *Natürliches System der Amphibien*, München, Stuttgart und Tübingen, 1830, p. 134.

† Gray, J. E., “A Synopsis of the Species of the Class Reptilia,” pp. 18, 19, Appendix to Vol. ix of Griffith’s *Animal Kingdom*, London, 1831.

‡ Gray, John Edward, *Synopsis Reptilium; or, Short Descriptions of the Species of Reptiles*, Part i., “Cataptracta,” London, 1831, pp. 44-50.

§ Bonaparte, C. L., *Saggio d’una Distribuzione Metodica degli Animali Vertebrati a Sangue Freddo*, Roma, 1832, p. 13.

|| Duméril, M. C., et G. Bibron, *Espéologie Générale*, Paris, 1835, Vol. ii, pp. 172, 199.

Fitzinger divides, in 1836,* the genus *Trionyx* into five sections :

Section 1. *Trionyx*, s. str.

- “ 2. *Aspidonectes*.
 “ 3. *Platypeltis*.
 “ 4. *Pelodiscus*.
 “ 5. *Amyda*.

The characters of *Trionyx*, s. str., are : “Ossicula marginalia distincta. Os cervicale vertebralibus conjunctum, in tota superficie rugosum. Ossa costalia postica contigua.” This section contains *T. granosus* Schweigg. (*T. punctata* Lac.).

The characters of *Aspidonectes* are : “Ossicula marginalia nulla. Os cervicale vertebralibus conjunctum, in tota superficie rugosum. Ossa costalia postica contigua.” (“Vertebralia septem; costalia utringue octo.”) This section contains *T. javanicus* Geoffr., *T. agyptiacus* Geoffr., *T. hurum* Gray, *T. indicus* Gray.

The characters of *Platypeltis* are : “Ossicula marginalia nulla. Os cervicale vertebralibus conjunctum, in medio tantum rugosum. Ossa costalia postica contigua.” (“Vertebralia sex, costalia utringue septem.”) This section contains *T. brogniarti* Schweigg., *T. ferox* Schweigg.

The characters of *Pelodiscus* are : “Ossicula marginalia nulla. Os cervicale a vertebralibus separatum, in medio tantum rugosum. Ossa costalia postica contigua.” This section contains *T. sinensis* Wigm., *T. laticatus* Bell.

The characters of *Amyda* are : “Ossicula marginalia nulla. Os cervicale a vertebralibus separatum, in medio tantum rugosum. Ossa costalia postica interposito vertebralibus discreta.” This section contains *T. subplanus* Geoffr., *T. muticus* Lesueur, *T. euphraticus* Geoffr.

Bonaparte ‡ follows mainly Fitzinger, but uses the generic names *Amyda* Schweigg. and *Trionyx* Wagler.

“AMYDA Schweigg.

† Ossa costalia postica contigua.

1. *Aspidonectes* Fitz.
2. *Platypeltis* Fitz.
3. *Pelodiscus* Fitz.

‡ Ossa costalia postica interposito vertebralibus discreta.

4. *Amyda* Fitz.

TRIONYX Wagler.”

In 1844, Gray § gave the following synopsis of the genera :

“A. Sternum broad, with valves over the feet. The margin of the shield supported by bones.

1. *Emyda*. Head moderate, sternal callosities five

* Fitzinger, Leopold, “Entwurf einer systematischen Anordnung der Schildkröten,” *Ann. Wien. Mus.*, i, 1836, pp. 119, 120, 127.

‡ Bonaparte, C. L., *Cheloniorum Tabula Analytica*, Ratisbæ, 1836.

§ *Catalogue of the Turtles, Crocodiles and Amphibians*, London, 1844, p. 46.

- B. Sternum narrow at each end. The margin of the shield expanded, flexible, thin. Sternal callosities four.
2. *Tyrse*. Head moderate, ovate, narrow in front; lips thin. Ribs eight pair, forming a disk with the vertebrae when young.
 3. *Dogania*. Head very large, dilated behind, narrow in front; lips thin. Ribs eight pair, not united in a solid disk until late in life.
 4. *Chitra*. Head dilated behind, broad and short in front; lips very large, swollen. Ribs eight pair.
 5. *Trionyx*. Head moderate, ovate, narrow in front. Ribs seven pair."

The following species are placed with the different genera :

Emyda—*E. punctata*, *E. senegalensis*.

Tyrse—*T. gangetica*, *T. javanica*, *T. perocellata*, *T. nilotica*, *T. rafect*.

Dogania—*D. subplana*.

Chitra—*Ch. indica*.

Trionyx—*T. ferox*, *T. muticus*.

Gray did not accept Fitzinger's classification, because, he says, the characters given by him "alter with the age of the animals" (p. 50).

It may be noted here that in 1843 Fitzinger* had separated the *Aspidonectes javanicus* Wagl. under the name of *Potamocheilus*, without giving any characters.

In 1854, Peters† established the genus *Cycloderma* for *Cycloderma frenatum* Peters.

The last work we may mention, before discussing the question, is that of Agassiz.‡

He retains the following genera :

Trionyx Wagler (*Emyda* Gray).

Chitra Gray.

Dogania Gray.

Cycloderma Peters.

Aspidonectes Wagl. (*Tr. javanicus*, *T. aegyptiacus*, *T. spinifer*, *A. asper*, *A. nuchalis*, *A. cnoryii*).

Platypeltis Fitz. (type, *Tr. ferox* Schweigger, *Tr. gangeticus* Cuv.).

Amymda Ag. (type, *T. muticus* Les.).

It is now the time to discuss the value of the different genera proposed. There is no doubt about *Trionyx* Wagler, for this genus has to stand with *Testudo punctata* Lacép. as the type; *Emyda* Gray and *Cryptopus* D. et B. are synonyms of it.

* Fitzinger, L., *Systema Reptilium Indobanar*, 1843, p. 30.

† Peters, W., "Ueber die auf seiner Reise nach Mosambique beobachteten Schildkröten," *Berl. Acad. Monatsb.*, 1854, pp. 215, 216.

‡ Agassiz, Louis, *Contributions to the Natural History of the United States*, Vol. i, Boston, 1857, pp. 394-397.

The question now is, What is the type of *Aspidonectes* Wagler?

Since *Aspidonectes javanicus* = *Testudo cartilaginea* Bodd. is fully figured by Wagler, Pl. ii, Figs. 1-12, and this species is also placed in *Aspidonectes* Fitzinger, I consider it as the type of *Aspidonectes*.

Besides this species, three others are mentioned by Fitzinger with *Aspidonectes* :

- T. aegyptiacus* Geoffroy = *Testudo triunguis* Forskal.
- T. horum* Gray.
- T. indicus* Gray.

None of these belong to *Aspidonectes*.

Aspidonectes contains besides the type, *Trionyx formosus* Gray and *Trionyx phuyrei* Theob.

Aspidonectes Wagl. may be characterized thus :

Posterior nares reduced in size by the inner and posterior extension of the maxillaries. Alveolar surface of lower jaw with a strong longitudinal symphyseal ridge (*vide* Boulenger). Eight pairs of pleuralia, last pair in contact in the median line; a single neural between the first pair of pleurals.

1. Type, *Testudo cartilaginea* Boddaert.
2. *Trionyx formosus* Gray.
3. *Trionyx phuyrei*, Theob.

The genus *Platypeltis* was established by Fitzinger for *T. brogniarti* Schweigg. and *T. ferox* Schweigg. Agassiz retains the genus *Platypeltis* with *Testudo ferox* Schweigg. as type. But the species considered as *Testudo ferox* Schweigger, by Agassiz, does not represent this species at all, but a new one, which I have called *Platypeltis agassizii*;* and this species belongs to a different genus than *Platypeltis* Fitz.

The *Platypeltis* Fitzinger is the same as *Aspidonectes* Agassiz. The type of *Platypeltis* Fitzinger is *Testudo ferox* Schneider. To this genus belong the following American species :

- Trionyx spiniferus* Les.
- Aspidonectes asper* Ag.
- “ *nuchalis* Ag.
- “ *emoryi* Ag.

The genus *Platypeltis* Fitzinger (name only) may be characterized in this way : Posterior nares not reduced in size by the inner and posterior extension of the maxillaries. Alveolar surface of lower jaw without a longitudinal symphyseal ridge; seven or eight pairs of pleuralia, last pair in contact in the median line; a single neural between the first pair of pleurals.

The question now is, To what genus does the form belong described by Agassiz as *Platypeltis ferox* and named by me *Platypeltis agassizii*? By

*Baur, G., "Notes on the American Trionychide," *Am. Nat.*, Dec., 1888, pp. 1121, 1122.

the study of different skulls I have found that this species *Aspidonectes* has to be associated with *Trionyx triunguis*, *T. sinensis*, *T. californianus*, *T. sinhoi* and *T. euphraticus*.

The following generic names have been applied to these forms since Fitzinger, in 1835, besides the many names given by Heude :

Pelodiscus Fitzinger, 1836 (*T. sinensis* Wieg., *T. labiatus* Bell), =

Amyda Fitz., 1836 (*T. euphraticus*, *T. triunguis*).

Tyrse Gray, 1844 (*T. triunguis*, *T. sinensis*, *T. euphraticus*).

Rafetus Gray, 1864 (*T. euphraticus*).

Laudemania Gray, 1869 (*T. sinensis*).

Fordia Gray, 1869 (*T. triunguis*).

Potamocheilus Gray, 1870 (*T. sinensis*).

Oscaria Gray, 1873 (*T. sinhoi*).

Of all these, *Pelodiscus* is the oldest, and I shall therefore introduce it again.

Pelodiscus Fitzinger (name only).

Posterior nares reduced in size by the inner and posterior extension of the maxillaries. Alveolar surface of lower jaw without longitudinal symphyseal ridge ; seven to eight pairs of pleuralia, last pair in contact in the median line ; a single neural between the first pair of pleurals.

Type, *Aspidonectes sinensis*, Wieg.

Other species : *P. triunguis* Forsk.

P. sinhoi Gray.

P. euphraticus Daud.

P. agassizii Baur.

P. californianus Rivers.

The genus *Amyda* Fitz. contains the three species *Trionyx cartilagineus*, *T. muticus* and *T. euphraticus*. Of these, *T. euphraticus* has already been placed in *Pelodiscus*.

The *Trionyx cartilagineus* was placed in a special genus by Gray, with the name *Doganis*, in 1844. *Trionyx muticus* was kept in *Amyda* by Agassiz, in 1857. Both these genera have to be retained, each with a single species.

Doganis Gray, 1844.

Posterior nares reduced in size by the inner extension of the maxillaries. Alveolar surface of lower jaw without a longitudinal symphyseal ridge ; eight pairs of pleuralia, all separated by neurals ; a single neural between the first pair of pleurals.

Type, *Trionyx subplanus* Geoffr.

Amyda Fitzinger, 1836 (name only), Agassiz, 1857.

Posterior nares not reduced in size by the inner extension of the maxillaries. Alveolar surface of lower jaw without a longitudinal symphys-

eal ridge; seven to eight pairs of pleurals, all separated by neurals; a single neural between the first pair of pleurals.

Type, *Trionyx muticus* Les.

There is one group left, consisting of three species, which cannot be united with any of the preceding genera, but which come nearest to *Aspidonectes* and to *Pelodiscus*. This group consists of the *Trionyx gangeticus* Cuvier, *Trionyx leithii* Gray and *Trionyx hurum* Gray. I shall use the generic name *Isola* for this group proposed by Gray in 1873 for *Trionyx leithii*.

Isola Gray.

Posterior nares reduced in size by the inner extension of the maxillaries. Alveolar surface of lower jaw without a strong longitudinal symphyseal ridge; eight pairs of pleurals, the posterior ones meeting in the middle line; two neurals between the first pair of pleurals.

Type, *Trionyx leithii* Gray.

The *Trionyx indicus* Gray, placed by Fitzinger with *Aspidonectes*, has been separated by Gray as long ago as 1844 under the generic name of *Chitra*. This genus, as well as *Pelochelys* Gray (1864), *Cycloderma* Peters (1854) and *Cyclanorbis* Gray (1852), I accept in the way as they have been used by Boulenger in the *British Museum Catalogue*.

I give now a table of the different genera, with the type species and their original locality, and also the names of the other species with their original localities.

Trionyx Geoffr., 1809 (name), Wagler (*Emyda* Boul.).

1. Type, *Testudo punctata* Lacépède, 1788.
Exact locality of type not known, India.
2. *Trionyx vitatta* Peters, 1854.
Locality of type, Goa, West Coast of British India.
3. *Trionyx scutata* Peters, 1868.
Locality of type, Pegu, British India.

Cycloderma Peters, 1854.

1. Type, *Cycloderma frenatum* Peters, 1854.
Locality of type, Zambesi river, East Africa.
2. *C. aubryi* A. Dum., 1856.
Locality of type, Gaboon, West Africa.

Cyclanorbis Gray, 1852.

1. Type, *Cryptopus senegalensis* Dum. et Bibr., 1835.
Locality of type,* Senegal, West Africa.
2. *C. elegans* Gray, 1869.
Locality of type, West Africa.

*The real type of *Cyclanorbis* is *Cyclanorbis petersii* Gray, 1852, from Gambia.

Aspidonectes Wagler, 1830 (name), *Aspidonectes* Fitzinger (part.) (*Trionyx*, i, B. 2, Boulenger).

1. Type, *Testudo cartilaginea* Boddaert, 1770.
Locality of type, Java.
2. *A. formosus* Gray, 1869.
Locality of type, Pegu.
3. *A. phayrei* Theobald, 1868.
Locality of type, Aracean range, west of Pegu.

Platypeltis Fitzinger, 1833 (name) (*Trionyx*, ii, Boulenger, part.).

1. Type, *Testudo ferox* Schweigger.
Locality of type, Savannah river, Ga.
2. *P. spinifer* Les.
Locality of type, Wabash river, Ind.
3. *P. asper* Ag.
Locality of type, Lake Concordia, La.
4. *P. nuchalis* Ag.
Locality of type, Cumberland river, Tenn.
5. *P. emoryii* Ag.
Locality of type, Lower Rio Grande river, Texas, near Brownsville.

Plodiscus Fitzinger, 1836 (name) (*Trionyx*, i, B. 3, Boulenger, part.).

1. Type, *Aspidonectes sinensis* Wieg., 1834.
Locality of type, near Makao.
2. *P. scinhoci* Gray, 1873.
Locality of type, Shanghai.
3. *P. euphraticus* Daudin, 1802.
Locality of type, Euphrates.
4. *P. triunguis* Forskal, 1775.
Locality of type, Nile.
5. *P. agassizii* Baur, 1886.
Locality of type, Western Georgia.
6. *P. californianus* Rivers.
Locality of type, Sacramento river, near Sacramento, Cal.

Dogania Gray, 1844 (*Trionyx*, i, A., Boulenger).

1. Type *Trionyx subplanus* Geoffr., 1809.
Locality of type, probably, Ganges.

Amyda Fitzinger, 1836 (name), Agassiz, 1857.

1. Type, *Trionyx muticus* Les., 1827.
Locality of type, Wabash river, Ind.

Isola Gray, 1873 (*Trionyx*, ii, B. 1, Boulenger).

1. Type, *Trionyx leithii* Gray.
Locality of type, Poonah.

2. *I. gangetica* Cuv.
Locality of type, Ganges.
3. *I. hurum* Gray, 1837.
Locality of type, Ganges (probably).

Chitra Gray, 1844.

1. Type, *Trionyx indicus* Gray, 1831.
Locality of type, Ganges, Pinang.

Pelochelys Gray, 1864.

1. Type, *Pelochelys cantorii* Gray, 1864.
Locality of type, Pinang.
2. *P. cummingii* Gray, 1864.
Locality of type, Philippines.
3. *P. poljakowii*, Strauch.
Locality of type, Fu-tschan.

It may be seen that in the circumscription of the species I have nearly completely followed Boulenger. This, however, is only provisional. I am fully convinced that Boulenger has gone too far in contracting species. This I may especially say in regard to his *Trionyx sinensis*, *triunguis* and *subplanus*. Further detailed studies have to decide about this question.

I do not believe at all that the system proposed here is finished; but I think that it gives a more correct idea of this difficult group of tortoises. Much remains to be done yet for an exact knowledge of the Asiatic and African forms. But it is only by an exhaustive study of the osteological characters that any light can be brought here.

January 15, 1892.

IV. THE SPECIES OF THE GENUS PSEUDEMYIS.

The genus *Pseudemys* was established by Gray* in 1855. The species referred to it were *Testudo concinna* LeC., *Emys hieroglyphica* Holbr. (*Pseudemys* (?) *hieroglyphica* Gray) and *Testudo rubiventris* LeC. (*Pseudemys serrata* Gray). Two years later, Agassiz † gave the generic name *Ptychemys* to the same group, distinguishing the following species:

- Ptychemys rugosa* Ag. (*Testudo rubiventris* LeC.).
- “ *concinna* Ag.
- “ *mobilienis* Ag.
- “ *hieroglyphica* Ag.
- “ *decussata* Ag.

It is evident that *Ptychemys* Ag. is a synonym of *Pseudemys* Gray. As the type of this genus I consider *Testudo concinna* LeC.

* Gray, J. E., *Catal. Shield Rept. Coll. Brit. Mus.*, Part i, “Testudinata,” London, 1855.

† Agassiz, Louis, *Contrib. Nat Hist. Un. States*, Vol. i, Boston, 1857.

Pseudemys concinna LeC., Gray.

This species was described by LeConte* under the name of *Testudo concinna* LeC. LeConte says: "Inhabits the rivers of Georgia and Carolina, where the beds are rocky. I have never seen them below Augusta on the Savannah, or Columbia on the Congaree." We have therefore to consider specimens from these localities as typical.

The upper jaw in this species is smooth, not notched, and without lateral cusps; the lower jaw is serrated and has a sharp median cusp on the symphysis. This species is characterized by its broad and low shell and its small head.

Pseudemys hieroglyphica Holbrook.

This species was described by Holbrook, in 1836, in the first edition of his *Herpetology* (Vol. i, p. 47, Pl. ii). The type now in the collection of the Philadelphia Academy came from the Cumberland river, Tenn.

A species very close to *Pseudemys concinna* LeConte, but distinguished by its elongated, narrow shell and its head, which is still smaller. The yellow stripes and dots on the head and neck are also very much more expressed than in *Pseudemys concinna* LeConte.

Pseudemys labyrinthica Lesueur, MSS., C. Duméril.

Boulenger places this species as a synonym of *Molaclemys geographica*, but there cannot be any doubt that it belongs to *Pseudemys*. It was originally described by C. Duméril, in *Catalogue méthodique de la Collection des Reptiles*, Paris, 1851, p. 13. The type specimens collected by Lesueur came from the Wabash river, Ill., probably from New Harmony.

That it cannot be *Molaclemys geographica* is at once seen from the description of the jaws: "Mâchoire inférieure dentelée, munie à son extrémité antérieure d'un crochet venant se loger dans une petite échancrure de la supérieure." Duméril correctly compares it with *P. hieroglyphica* Holbr., and says: "Cette E. diffère de la précédente [hieroglyphica] par la forme de sa carapace, dont l'ovale est moins allongé, et par l'élévation quelle présente sur la ligne vertébrale, qui est au contraire déprimée dans l'E. hiéroglyphique, et enfin par le volume proportionnellement plus considérable de la tête."

This species shows the coloration of head and neck of *P. hieroglyphica*, but the head is larger and the shell more as in *P. mobiliensis*, but by far not so large.

I have examined two heads of this form, from Illinois, preserved in alcohol; it is mentioned as *Pseudemys concinna* LeC. by H. Garman in "Notes on Illinois Reptiles and Amphibians" (*Illinois State Laboratory of Nat. Hist.*, pp. 185, 186). This species is said to be found at Mt. Carmel, Ill.

* LeConte, J., "Description of the Species of North American Tortoises," *Ann. Lyr. Nat. Hist.*, New York, Vol. iii, Febr., 1836.

Pseudemys floridana LeC.

In 1830, LeConte described a tortoise from the St. John's river, in East Florida, under the name of *Testudo floridana*. This species was recognized as distinct by Holbrook, in 1842, and figured (Pl. viii). Agassiz stated that it has to be considered a synonym of *P. concinna* LeC., and it seems that all recent authors have followed him.

There is no doubt that this species is distinct from *Pseudemys concinna* LeC. and *P. mobiliensis* Holbr.

The description given by LeConte is very good. The species is at once distinguished by its oval form and the great elevation of the carapace and its color. The carapace is not emarginate in front. It has a very dark-brown color, with numerous irregular lines of yellow. The marginals are also dark brown and have only one vertical median yellow line and are without the yellow concentric lines so characteristic for *P. concinna* and *P. mobiliensis*. The carapace is much more arched than in *P. mobiliensis* and nearly forms a half circle. The skull is also larger than in this species and the jaws are not serrated. This species seems to be restricted to Florida and Southern Georgia.

Pseudemys texana, sp. nov.

Agassiz mentions specimens of his *Ptychemys mobiliensis* "from Guadalupe mountains, Pecos river, Texas, and New Leon, near Cadereita, Mexico," and also young specimens collected in Texas by Mr. G. Stolley.

I have examined different specimens of this so-called *Ptychemys mobiliensis*, from Texas, and reach the conclusion that it belongs to a new species of *Pseudemys* related to *P. rubiventris* LeC., which may be called *Pseudemys texana*. As typical specimen of this new species I consider a stuffed specimen, No. 246, of the Philadelphia Academy, collected by Dr. Hermann in San Antonio, Texas.

Pseudemys texana, sp. nov.

Shell very thin behind, posterior border serrated, longitudinally rugose; nuchal long and slender; upper shell brown, with yellow reticulations similar to *Pseudemys concinna*; shell not much elevated. Plastron emarginated behind, yellow or with brown markings.

Skull small, similar to *P. rubiventris*; upper jaw notched in the centre, with a rounded tooth on each side, not so prominent as in *P. rubiventris*. Lower jaw similar to *P. rubiventris*. The coloration of the head quite different from the other species. A yellow longitudinal spot behind the eye; above this, a yellow line ending in a long longitudinal spot above the temples; from the lower posterior portion of the eye a yellow line appears, sending a branch upwards in front of tympanic cavity, and continues behind on the neck. Three very strong yellow and some slender yellow stripes on lower face of neck.

Locality of type, San Antonio, Texas.

There is a shell of the same species in the Philadelphia Academy. No. 247. It has the Smithsonian Institution number 7173 and was collected near Old Fort Cobb, I. T. The soft parts, limbs and head are preserved in alcohol at the Smithsonian. The two specimens mentioned by Agassiz are also at the Smithsonian (No. 80, Guadalupe mountains, Pecos river, Texas, and No. 76, New Leon, near Cadereita, Mexico) and belong to this species.

I consider *Pseudemys texana* as the representative of *Pseudemys* in the southern portions of this country west of the Mississippi—Texas, Indian Territory, Northern Mexico.

Pseudemys rubiventris LeC., Baur.

This species has been first mentioned by Say,* who described it erroneously as *Emys serrata* Daudin, in 1825. LeConte † introduced it as a new species under the name of *Testudo rubiventris* LeC., the "red-bellied terrapin, vulg." According to LeConte, it inhabits "in rivers from New Jersey to Virginia, chiefly in such as are rocky." He says that they are very numerous in the Delaware, near Trenton; specimens from this locality may be considered as typical, therefore.

In this form both jaws, especially the lower one, are strongly serrated; the upper one is notched mesially and has a cusp on each side; the lower jaw has a strong, median, serrated cusp and a notch on each side of it.

Pseudemys alabamensis, sp. nov.

In the collection of Mr. Gustave Kohn, of New Orleans, La., I found two specimens from Mobile, Ala., which are closely allied to *P. rubiventris*. They are at once distinguished, however, by their much more arched shell. This species has been noted by Agassiz as *Ptychemys mobiliensis*. It is, however, totally different from this, having the structure of the skull of *Pseudemys rubiventris* LeC. The shell is much more arched than in *P. rubiventris*; the coloration is like that in the latter form, but the plastron is yellow, or yellow with brown reticulations or dots.

Locality of types, Mobile bay, Ala. Collection of Mr. G. Kohn, New Orleans, La. This species exists in different museums, with the name *P. mobiliensis* Holbr.

Pseudemys mobiliensis Holbr.

The types of this species are from Alabama and are Nos. 241 and 242 of the Philadelphia Academy collection. I have examined the types and found that they are very close to *P. concinna* LeC. The skull agrees exactly with that of *P. concinna*, but is considerably larger. There is no notch in the upper jaw and no lateral cusps; the lower jaw only has a

* Say, Thomas, "On the Fresh-water and Land Tortoises of the United States," *Journ. Acad. Nat. Sc.*, Philad., Vol. iv, Part 2, 1825.

† LeConte, J., l. c.

sharp median hook, but no lateral notches. The upper jaw is very finely, the lower one strongly, serrated. A number of specimens in Mr. Kohn's collection from Mobile bay, Ala., and New Orleans, La., agree with the type.

Skull like *Pseudemys concinna* LeC., but larger; shell very much more arched, especially in front, than that of *P. concinna*; coloration as in the latter form. Animal much larger than *P. concinna*, the upper shell reaching a length of 385 mm. (over curve).

We have, therefore, the following species of *Pseudemys*:

Pseudemys concinna LeC.

“ *hieroglyphica* Holbr.

“ *labyrinthica* C. Dum.

“ *floridana* LeC.

“ *mobilicensis* Holbr.

“ *rubiventris* LeC.

“ *alabamensis* Baur.

“ *texana* Baur.

These forms can be arranged in two series.

A. Both jaws strongly and coarsely serrated; upper one notched medially, with a cusp on each side. Lower jaw with a median cusp.

1. *Pseudemys rubiventris* LeC., Baur.

Type from Delaware, near Trenton.

2. *Pseudemys alabamensis* Baur.

Syn., *Ptychemys mobiliensis* Ag. (part).

Type from Mobile bay, Ala. In the collection of Mr. G. Kohn, New Orleans, La.

3. *Pseudemys texana* Baur.

Syn., *Ptychemys mobiliensis* Ag. (part).

Type from San Antonio, Texas. No. 246 Philadelphia Academy.

B. Generally lower jaw only strongly and coarsely serrated; upper without median notch, no cusps on the sides. Lower jaw with a median cusp.

1. *Pseudemys concinna* LeC., Gray.

Type from upper parts of rivers of South Carolina and Northern Georgia.

2. *Pseudemys mobiliensis* Holbr., Baur (non Ag., non Boul.).

Type from Mobile, Ala. Philadelphia Academy, Nos. 241, 242.

Syn., *Emys orthonix* Wied.

3. *Pseudemys floridana* LeC., Baur.

Type from St. John's river, Eastern Fla.

4. *Pseudemys hieroglyphica* Holbr., Gray.

Type from Cumberland river, Tenn. No. 217, Philadelphia Academy.

5. *Pseudemys labyrinthica* (Les. MSS.) C. Dum., Gray.

Type from Wabash river, Ill. Museum Natural History, Paris.

Stated Meeting, May 5, 1893.

Vice-President, Dr. RUSCHENBERGER, in the Chair.

Correspondence was submitted as follows :

Letters of envoy were received from the K. Sächsische Gesellschaft der Wissenschaften, Leipzig; Bath and West and Southern Counties Society, Bath, Eng.; Royal Statistical Society, Meteorological Office, London, Eng.; Texas Academy of Science, Austin.

Letters of acknowledgment (139) were received from the Naturforschende Gesellschaft des Osterlandes, Altenberg, Germany; Deutsche Seewarte, Hamburg, Germany; Profs. Aristides Brezina, Matthew Much, Friederich Müller, Vienna, Austria; Société de l'Histoire de France, Paris; Sir John Evans Hensel, Hempstead, England; Philosophical and Literary Society, Leeds, England; Royal Astronomical Society, Victoria Institute, Royal Society, Royal Institution, Zoölogical Society, Institution of Civil Engineers, Royal Statistical Society, Royal Meteorological Society, Mr. C. Jublin Dannfeld, London, England; Natural History Society, Newcastle-on-Tyne, England; Sir Lowthian Bell, Northallerton, England; Radcliffe Observatory, Prof. J. J. Sylvester, Oxford, England; Mr. Alfred R. Wallace, Parkstone, Dorset, England; Academy of Science, Rochester, N. Y.

Accessions to the Library were reported from the Zoologisch-Botanische Gesellschaft, K. K. Naturehistorische Hofmuseum, Vienna, Austria; Deutsche Seewarte, Hamburg, Germany; K. Sächs. Gesellschaft der Wissenschaften, Leipzig; Ministero di Agricoltura, Industria e Commercio, Rome, Italy; R. Osservatorio Astronomico, Turin, Italy; Royal Institution, Meteorological Council, Royal Microscopical Society, London, England; American Academy of Arts and Sciences, Cambridge, Mass.; Connecticut Academy of Arts and Sciences, Yale University, New Haven; American Museum of Natural History, Messrs. J. Wiley & Sons, New York, N. Y.; Smithsonian Institution, U. S. Department of Agriculture, Mr. J. C.

Mendenhall, Washington, D. C.; Prof. Alexander Macfarlane, Austin, Tex.; University of Michigan, Ann Arbor; University of Nebraska, Lincoln; Agricultural Experiment Stations, Amherst, Cambridge, Mass.; New Haven, Conn.; Newark, N. J.; Morgantown, W. Va.; Byran, Tex.; Lafayette, Ind.; Lincoln, Neb.

Mr. Fraley moved that the letter in reference to the Halde-
man Indian collection be referred to the Curators, to report
to the Society. Remarks were made by Dr. Morris, Mr.
Prime and Prof. Cope. The Chairman observed that no
objects should be loaned, according to a By-Law of the Society,
except for the purpose of study. The motion was carried.

A portrait of the late Matthew Carey was presented to the
Society, on behalf of the Hon. Henry Carey Baird.

On motion of Curator Dr. Morris, the Secretaries were re-
quested to return to Mr. Henry C. Baird the thanks of the
Society for the gift of the portrait of Matthew Carey.

Prof. Cope presented a paper for the Proceedings, by title,
"Notes on the Classification and Taxonomy of the Testudi-
nata," by G. Baur, University of Chicago.

Pending nominations for membership, Nos. 1249, 1250,
1253, 1254, 1255, 1256, 1257, were read.

Dr. J. Cheston Morris presented a communication from the
Curators, which was received and referred to the Hall Com-
mittee for reply.

Dr. Morris moved that the Curators be authorized to dis-
pose of such objects as are of no value to the Society.

Discussion by Dr. Brinton, Prof. Cope, Mr. Fraley, Mr.
Prime, Dr. Morris. The motion was adopted.

Prof. Cope requested information about the programme of
the Sesqui-Centennial Celebration.

Dr. Brinton gave information as to the action of the Com-
mittee appointed for the purpose.

Remarks were made by Prof. Cope, Dr. Brinton, Dr. Morris,
Mr. Fraley on the publication in reference to the proceedings
of the Society in the public papers, with reference to the
report of the proceedings of the Society at a previous meeting.

And the meeting was adjourned by the presiding member.

Stated Meeting, May 19, 1893.

The President, Mr. FRALEY, in the Chair.

In the absence of all the Secretaries at the opening of the meeting, Mr. Lyman was appointed Secretary *pro tem*.

Mr. Cramp, a newly elected member, was presented to the President, and took his seat.

Letters of envoy were received from the Royal Geographical Society of Australasia (Victoria Branch), Melbourne; Geological Survey of India, Calcutta; Université Royale, Lund, Sweden; K. K. Astronomisch-Meteorologische Observatorium, Triest, Austria; Musée Guimet, Bureau des Longitudes, Paris, France.

Accessions to the Library were reported from the Royal Geographical Society of Australasia (Victoria Branch), Melbourne; Finska Litteratur, Salskapet, Helsingfors; Lund University, Lund, Sweden; M. W. Pleyte, Leiden, Holland; Observatorio Marittimo, Trieste, Austria; Naturwissenschaftliche Verein, Bremen, Germany; Naturforschende Gesellschaft, Zurich, Switzerland; Academie N. des Sciences, Bordeaux, France; Société N. des Sciences Naturelles et Mathématiques, Cherbourg; Société de Borda, Dax; Academie des Arts et Belles-Lettres, Dijon; Union Geographique du Nord de la France, Donai; Société des Sciences Naturelle et Archæologiques de la Creuse, Guéret; Société des Sciences Naturelles, La Rochelle; Comité de Rédaction des Annales de la Faculté des Sciences, Marseille; Musée Guimet, Museum d'Histoire Naturelles, Société Zoologique de France, Société D'Anthropologie, Bureau des Longitudes, Société N. des Antiquaires de France, Paris; Société des Antiquaires de la Morinie, Saint Omer; Société de Geographie, Toulouse, France; Société de Geographie, Lisbon, Portugal; Geological Society, Manchester, Eng.; Natural History Society, Montreal, Canada; Boston Public Library; Academy of Sciences, New York;

Mr. Burnet Landreth, Bristol, Pa.; Mr. William John Potts, Camden, N. J.; Franklin Reformatory Home for Inebriates, Prof. E. D. Cope, Messrs. Alexander E. Outerbridge, Joseph Wharton, Philadelphia; U. S. National Museum, Prof. Edward Goodfellow, Washington, D. C.; Agricultural Experiment Stations, Geneva, N. Y.; Raleigh, N. C.; Lake City, Fla.; Brookings, S. Dak.

The donations to the library were announced.

The minutes of the Council meeting of the 12th of May were read. The resolution

That the Council recommend to the Society the appointment of Messrs. Meehan, Houston and Price as a Committee to Examine the Catalogue of the Martindale Library, in order to ascertain if any books contained therein are important to complete our list, and if so, to purchase the same at a cost not exceeding \$100—provided the money can be obtained from the income of the Michaux Fund, or by subscription.

recommended by the Council was considered.

Mr. Prime moved that Dr. Rothrock be added to the Committee. Carried.

Mr. Prime moved to amend by striking out from the last clause the words, "or by subscription." Carried.

The resolution so amended was carried.

The business of the election of new members was taken up.

Nominations Nos. 1250, 1253, 1254, 1255, 1256, 1257, 1258 and 1259 were read, spoken to, and balloted for.

Prof. Barker and Mr. Price were appointed tellers by the President.

Prof. Cope made a communication in regard to some stone implements occurring in Maryland, on the Potomac, the simplest yet found by him in forty years' collecting. The locality is two or three miles from the Potomac, is one-half mile to one mile in length, in material that is supposed to be derived from the Triassic and that has apparently been carried by floating ice. The locality is traversed by a small stream, with small hills on each side. There is a bed of reddish clay, up to six feet in thickness, filled with cobble-stones, many of them broken, and many worked; and some of them

have the external portions of the original shape entirely removed. Some of the most numerous class of them were exhibited, and have a portion of the original surface; others have a small portion of it; and others none at all. Many hundreds have been carried away by inhabitants of Washington, and many by Mr. W. H. Holmes, of the Bureau of Ethnology there. The method of manufacture was described; showing that the fractures could not be natural, but must be artificial. The question is, What are these objects? In Europe similar objects are reckoned as made by the earliest men, and are found at the lowest bed of the cave deposits. They are not polished. Now in Switzerland, for example, the paleolithic man is quite definitely associated with certain extinct animals. The later paleolithic man was an artist, while the following neolithic men were less artistic. Now, however, the Washington men insist that these ruder implements are only the imperfect or rejected implements of later men, merely the residue and rejected work of neolithic men; and in part the effect of weathering. One reason given why the more perfect implements are not found with them is, that the better ones have been carried away. The evidence in America is less perfect than in Europe, yet it is against supposing that the makers of the imperfect implements also had better ones. None of the better ones have been found in the whole region. The geological part of the investigation by the Washington men has been well done. At Trenton, however, they are thoroughly opposed by the good authority of Prof. F. W. Putnam. The history of man in America may be affected by the result of the discussion; but not that of European man. In America, too, the study of the caves has not been studied so far as in Europe; and the cave deposits give much the most trustworthy evidence. Mr. Clarence B. Moore has made important discoveries in Florida. He found a ramus of the lower jaw of a dog in a shell heap there this past winter. The shell heaps are post-Columbian. But this dog does not appear to be the present domestic dog. The jaw has three premolar teeth, instead of four, a deficiency which is

rare in the recent domesticated or wild dogs. There are also other peculiarities. Probably it is an extinct species, and it is a normal healthy specimen.

Prof. Ryder made a written communication for the Proceedings, entitled, "The Adaptive Forms and the Vortex Motion of the Substance of the Red Corpuscles of Vertebrates." He gave orally the substance of the paper.

The tellers reported the following named to have been duly elected members of the Society :

- 2218. Hon. Charles P. Daly, New York, N. Y.
- 2219. Prof. Isaac H. Hall, New York, N. Y.
- 2220. Gen. Isaac J. Wistar, Philadelphia.
- 2221. Mr. Edward Vincent d'Invilliers, Philadelphia.
- 2222. Prof. Waterman L. Hewitt, Ithaca, N. Y.
- 2223. Dr. Justin Winsor, Cambridge, Mass.
- 2224. Dr. William Hyde Appleton, Swarthmore, Pa.
- 2225. Prof. James E. Rhoads, Bryn Mawr, Pa.

Mr. Blodget obtained unanimous leave to make a communication. He had prepared a series of ten maps to show the resources of the State of Pennsylvania for the Chicago World's Fair. The maps are some thirty inches by twenty inches. Bituminous coal, oil and other products are represented on the series of maps, showing their past and present importance. The true capitalization of the yearly industrial earnings of the State he finds to be about \$10,000,000,000. The results have been reached by five or six months' labor.

And the Society was adjourned by the President.

Sept. 1, 1893.]

233

PROCEEDINGS
OF THE
AMERICAN PHILOSOPHICAL SOCIETY
HELD AT PHILADELPHIA FOR PROMOTING USEFUL KNOWLEDGE.

VOL. XXXI.

JULY TO DECEMBER, 1893.

NO. 142.

Stated Meeting, September 1, 1893.

ERRATUM.

Page 132, thirteenth line from top, *should read:*

“The President was authorized to appoint a suitable person to prepare the usual obituary notice.”

An invitation from the New Haven Colony Historical Society, New Haven, Conn., to be present at the dedication of the new building erected as a memorial to James E. and Caroline A. English, to take place September 28, 1893, at 8 P.M.

A circular from the Congrès International de Zoologie, Paris, relative to the prizes which will be awarded by the Congrès.

A circular from the Anthropological Society of Washington in regard to the Citizenship Prizes to be awarded for essays on specified subjects.

A letter from the U. S. Coast and Geodetic Survey, Washington, D. C., requesting certain numbers of the Society's Proceedings and Transactions to complete their set.

PROCEEDINGS
OF THE
AMERICAN PHILOSOPHICAL SOCIETY
HELD AT PHILADELPHIA FOR PROMOTING USEFUL KNOWLEDGE.

VOL. XXXI.

JULY TO DECEMBER, 1893.

No. 142.

Stated Meeting, September 1, 1893.

Prof. ALBERT H. SMYTH in the Chair.

Correspondence was submitted as follows :

Acknowledgments of election to membership were received from

Prof. Isaac H. Hall, New York.

Gen. Isaac J. Wistar, Philadelphia.

Mr. Edward Vincent d'Invilliers, Philadelphia.

Prof. Waterman L. Hewitt, Ithaca, N. Y.

Prof. Justin Winsor, Cambridge, Mass.

Prof. William Hyde Appleton, Swarthmore, Pa.

President James E. Rhoads, Bryn Mawr, Pa.

An invitation from the New Haven Colony Historical Society, New Haven, Conn., to be present at the dedication of the new building erected as a memorial to James E. and Caroline A. English, to take place September 28, 1893, at 8 P.M.

A circular from the Congrès International de Zoologie, Paris, relative to the prizes which will be awarded by the Congrès.

A circular from the Anthropological Society of Washington in regard to the Citizenship Prizes to be awarded for essays on specified subjects.

A letter from the U. S. Coast and Geodetic Survey, Washington, D. C., requesting certain numbers of the Society's Proceedings and Transactions to complete their set.

The following communication was read and referred to the Curators:

AMERICAN HISTORICAL ASSOCIATION, SMITHSONIAN INSTITUTION,
WASHINGTON, D. C., August 2, 1893.
THE SECRETARY OF THE AMERICAN PHILOSOPHICAL SOCIETY,
PHILADELPHIA, PA. :

Dear Sir :—I am desirous of obtaining for the use of the American Historical Association definite information regarding the collections of the various Historical Societies in the United States. I have been informed that under the supervision of your Society an interesting collection of historical objects has grown up. May I ask your assistance in furnishing me with a few lines explaining the scope of the collection, with a little history of its growth, and the names of those who have been and are now most conspicuous in its development. If a catalogue of the collection has been published, may I beg that you will furnish me with a copy.

I am, sir, yours very respectfully,

A. HOWARD CLARK,

Assistant Secretary of the American Historical Association, Curator Hist. Coll., U. S. N. M.

Letters of envoy were received from the Geological Survey of India, Calcutta; Royal Society of New South Wales, Sydney; Societas pro Fauna et Flora Fennica, Helsingfors, Finland; Fondation de P. Teyler van der Hulst, Harlem, Holland; K. Danske Videnskabernes Selskab, Copenhagen; Université Royale, Lund, Sweden; Naturforschende Verein, Brünn, Austria; Verein für Erdkunde, Dresden, Saxony; Wetterauische Gesellschaft für die Gesammte Naturkunde, Hanau, Hesse; K. Sächsische Gesellschaft der Wissenschaften, Leipzig, Saxony; Gesellschaft zur Beförderung der Gesammten Naturwissenschaften, Marburg, Prussia; Naturwissenschaftliche Verein, Osnabrück, Prussia; Royal Observatory, Greenwich, England; Zoölogical Society, Meteorological Office, Statistical Society, London, England; Museum of Comparative Zoölogy, Cambridge, Mass.; Meteorological Observatory, New York; Direccion General de Estadistica, Mexico, Mexico; Observatorio N. Argentino, Cordoba, Argentine Republic.

Letters of acknowledgment (Trans. xvii, 3, and xviii, 1) were received from the Geological and Natural History Survey, Ottawa, Canada; Public Library, Boston, Mass.; Museum of

Comparative Zoölogy, Cambridge, Mass.; American Antiquarian Society, Worcester, Mass.; Yale University, New Haven, Conn.; University of the State of New York, Albany; Buffalo Library; New York Historical Society; Astor Library, New York; United States Military Academy, West Point, N. Y.; New Jersey Historical Society, Newark, N. J.; Academy of Natural Sciences; Franklin Institute, Philadelphia; Smithsonian Institution, Washington, D. C.; University of California, Berkeley; State Historical Society of Wisconsin, Madison; Kansas Academy of Science, Topeka.

Letters of acknowledgment were received from the Anthropologische Gesellschaft, Profs. Franz Ritt v. Hauer, F. S. Krauss, Vienna, Austria (139); Anthropologische Gesellschaft, K. Bibliothek, Gesellschaft für Erdkunde, K. P. Meteorologische Institut, Physikalische Gesellschaft, Berlin, Prussia (139); University of Bonn (139); K. Sächsische Meteorologische Institut, Chemnitz (139); K. Sächsische Altertumsverein, Verein für Erdkunde, Dresden (139); Prof. Otto Böhtlingk, Leipzig, Germany (139, 140); K. P. Geodätische Institut, Potsdam, Prussia (139); Naturwissenschaftliche Verein für Schleswig-Holstein, Kiel, Prussia (139); Verein für Vaterländische Naturkunde in Württemberg, Stuttgart (139); Prof. Robert W. Bunsen, Heidelberg, Germany (139); Société de Géographie (131-134), Naturhistorische Gesellschaft (139), Schweizerische Naturforschende Gesellschaft, Berne (139); Prof. Carl Vogt, Geneva, Switzerland (139); Société Vaudoise des Sciences Naturelles, Lausanne (139, 140); Mr. Samuel Timmins, Arley, Coventry, England (139, 140); Philosophical Society, Cambridge, England (139, 140); Sir Rawson W. Rawson (139), Institution of Civil Engineers, London, England (131-139); Geographical Society, Manchester, England (139, 140); R. Geological Society of Ireland, Dublin (139, 140); Royal Observatory, Prof. James Geikie, Edinburgh, Scotland (139, 140); Société d'Histoire et d'Archéologie, Chalon-sur-Saone, France (137-140); Société N. des Sciences Naturelles et Mathématique, Cherbourg, France (136); Université de Lyon (139, 140); Rédaction de "Cosmos," Paris,

France (131-136, 139); Yale University, New Haven, Conn. (139); Prof. G. L. Goodall, Cambridge, Mass. (137-139); Prof. James Ellis Humphrey, Weymouth Heights, Mass. (137-140); Kentucky Historical Society, Frankfort (137); Instituto Fisico-Geografico Nacional, San Jose de Costa Rica, Central America (138); Museo Nacional, Santiago, Chile (137).

Letters of acknowledgment (140) were received from the Geological Survey, Ottawa, Canada; Université Laval, Hon. J. M. Le Moine, Quebec; Dr. Alfred R. C. Selwyn, Montreal; Canadian Institute, Toronto; Bowdoin College Library, Brunswick, Me.; Experiment Station, Orono, Me.; Society of Natural History, Portland, Me.; Prof. Charles H. Hitchcock, Hanover, N. H.; Amherst College Library, Amherst, Mass.; Marine Biological Laboratory, Massachusetts Institute of Technology, Boston; Society of Natural History, Massachusetts Historical Society, State Library of Massachusetts, Messrs. T. M. Drown, Hamilton A. Hill, Robert C. Winthrop, Boston, Mass.; Museum of Comparative Zoölogy, Prof. G. L. Goodall, Mr. Robert N. Toppan, Cambridge, Mass.; Free Public Library, New Bedford, Mass.; Rev. Edward E. Hale, Roxbury, Mass.; Essex Institute, Salem, Mass.; American Antiquarian Society, Worcester, Mass.; Rhode Island Agricultural Experiment Station, Kingston, R. I.; Providence Franklin Society, Rhode Island Historical Society, Providence; Mr. George F. Dunning, Farmington, Conn.; Hartford Theological Seminary, Connecticut Historical Society, Hartford; New Haven Colony Historical Society, Profs. O. C. Marsh, H. A. Newton, W. D. Whitney, New Haven, Conn.; Prof. James Hall, Albany, N. Y.; Society of Natural Science, Buffalo Library, Buffalo, N. Y.; Profs. T. F. Crane, B. G. Wilder, Ithaca, N. Y.; Astor Library, American Museum of Natural History, New York Historical Society, New York Academy of Medicine, New York Hospital, Profs. Joel A. Allen, Daniel Draper, Henry F. Osborn, John J. Stevenson, New York, N. Y.; Vassar Brothers' Institute, Poughkeepsie, N. Y.; Prof. W. Le Conte Stevens, Troy, N. Y.; Oneida Historical Society, Utica, N. Y.; U. S. Military Academy, West Point, N. Y.; Free Public

Library, Jersey City; New Jersey Historical Society, Newark; Profs. W. Henry Green, C. A. Young, Princeton, N. J.; Dr. Robert H. Allison, Ardmore, Pa.; Prof. Robert W. Rogers, Carlisle, Pa.; Prof. M. H. Boycé, Coopersburg, Pa.; Hon. Eckley B. Coxe, Driffton, Pa.; Dr. Traill Green, Prof. J. W. Moore, Rev. Thomas C. Porter, Easton, Pa.; Mr. Andrew S. McCreath, Harrisburg, Pa.; Prof. Lyman B. Hall, Haverford, Pa.; Mr. John Fulton, Johnstown, Pa.; Linnean Society, Lancaster, Pa.; Mr. P. F. Rothermel, Linfield, Pa.; Dr. F. A. Muhlenberg, Reading, Pa.; University of Pennsylvania, Library Company of Philadelphia, *The Medical News*, Wagner Free Institute of Science, Academy of Natural Sciences, Historical Society of Pennsylvania, Numismatic and Antiquarian Society, Mercantile Library, Admiral E. Y. Macauley, Hon. James T. Mitchell, Hon. Henry Reed, Profs. John Ashhurst, Jr., E. D. Cope, F. A. Genth, Jr., H. V. Hilprecht, E. O. Kendall, J. P. Lesley, John M. Maisch, Albert H. Smyth, Drs. John H. Brinton, Persifor Frazer, George Friebis, John Marshall, George R. Morehouse, Isaac Norris, Charles A. Oliver, C. N. Peirce, W. S. W. Ruschenberger, H. Clay Trumbull, William H. Wahl, Messrs. Arthur E. Brown, R. Meade Bache, Charles Bullock, Thomas M. Cleemann, Patterson Du Bois, Robert Patterson Field, J. S. Harris, Francis Jordan, Jr., William W. Jefferis, Henry Phillips, Jr., Franklin Platt, Theodore D. Rand, J. G. Rosengarten, L. A. Scott, Talcott Williams, Charles Stewart Wurts, Mrs. Helen Abbott Michael, Philadelphia; Prof. John T. Carll, Pleasantville, Pa.; Mr. Heber S. Thompson, Pottsville, Pa.; Rev. George W. Anderson, Rosemont, Pa.; Dr. John Curwen, Warren, Pa.; Mr. Philip P. Sharples, Hon. Washington Townsend, West Chester, Pa.; Mr. William M. Canby, Wilmington, Del.; U. S. Naval Institute, Annapolis, Md.; Enoch Pratt Free Library, Baltimore, Md.; Mr. T. Leeper Patterson, Cumberland, Md.; Smithsonian Institution, U. S. Naval Observatory, Anthropological Society, U. S. Weather Bureau, U. S. Coast and Geodetic Survey, Library Surgeon-General's Office, U. S. Geological Survey, Dr. J. S. Billings, Prof. S. F. Emmons, Dr. W. J. Hoff-

man, Prof. Charles A. Schott, Mr. W. B. Taylor, Washington, D. C.; University of Virginia, Charlottesville; Journal U. S. Artillery, Fortress Monroe, Va.; Agricultural Experiment Station, Morgantown; Prof. J. W. Mallet, University of Virginia, Va.; Agricultural Experiment Station, Raleigh, N. C.; Georgia Historical Society, Savannah; University of Alabama, Tuscaloosa; Agricultural Experiment Station, Baton Rouge, La.; Texas Academy of Science, Austin; Museo Oaxaqueño, Oaxaca de Juárez, Mex.; Observatorio Astronomico Nacional, Tacubaya, Mex.; Agricultural Experiment Station, Las Cruces, N. M.; Prof. E. W. Claypole, Akron, O.; University of Cincinnati, Cincinnati Observatory, Society of Natural Science, Cincinnati, O.; Oberlin College; Rev. Henry S. Osborn, Oxford, O.; Kentucky Historical Society, Frankfort; Dr. Robert Peter, Lexington, Ky.; University of California; Prof. Joseph LeConte, Berkeley, Cal.; Lick Observatory; Mt. Hamilton, Cal.; Prof. J. C. Branner, Palo Alto, Cal.; Prof. Daniel Kirkwood, Riverside, Cal.; Prof. George Davidson, San Francisco, Cal.; Geological Survey of Missouri, Jefferson City; Academy of Sciences, St. Louis, Mo.; Arkansas Agricultural Experiment Station, Fayetteville; Purdue Experiment Station, La Fayette, Ind.; Historical Society, Chicago, Ill.; Academy of Natural Sciences, Davenport, Ia.; State University of Iowa, Iowa City; Wisconsin State Historical Society, Madison; Agricultural Experiment Station, Lincoln, Neb.; State Agricultural College, Manhattan, Kans.; Academy of Sciences, State Historical Society, Washburn College, Topeka, Kans.; Agricultural Experiment Station, St. Anthony Park, Minn.; Tacoma Academy of Science, Tacoma, Wash.

Letters of acknowledgment (141) were received from Dr. Charles B. Dudley, Altoona, Pa.; Dr. Robert H. Alison, Ardmore, Pa.; Prof. James E. Rhoads, Bryn Mawr, Pa.; Dr. Charles F. Himes, Carlisle, Pa.; Prof. Martin H. Boyé, Coopersburg, Pa.; Hon. Eckley B. Cox, Drifton, Pa.; Drs. Traill Green, J. W. Moore, Thomas C. Porter, Easton, Pa.; Mr. Andrew S. McCreath, Harrisburg, Pa.; Mr. John Ful-

ton, Johnstown, Pa.; Linnean Society, Lancaster, Pa.; Numismatic and Antiquarian Society, Historical Society of Pennsylvania, Academy of Natural Sciences, Library Company of Philadelphia, Hon. Joseph Allison, Prof. John Ashhurst, Jr., Messrs. R. Meade Bache, Henry C. Baird, Cadwalader Biddle, Patterson Du Bois, Jacob B. Eckfeldt, Robert P. Field, Dr. Henry Hartshorne, Prof. H. H. Houston, Messrs. William A. Ingham, E. V. d'Invilliers, Francis Jordan, Jr., Prof. J. P. Lesley, Dr. John Marshall, Mrs. Helen Abbott Michael, Drs. Isaac Norris, Charles A. Oliver, C. N. Peirce, William Pepper, Messrs. Franklin Platt, Theodore D. Rand, J. G. Rosengarten, Dr. W. S. W. Ruschenberger, Prof. Benjamin Sharp, Rev. H. Clay Trumbull, Prof. James Tyson, Messrs. W. P. Tatham, D. K. Tuttle, Samuel Wagner, Philadelphia; Prof. John F. Carll, Pleasantville, Pa.; Mr. Heber S. Thompson, Pottsville, Pa.; Rev. F. A. Muhlenberg, Reading, Pa.; Dr. W. H. Appleton, Swarthmore, Pa.; Philosophical Society, Mr. Philip P. Sharples, Hon. Washington Townsend, Prof. J. T. Rothrock, West Chester, Pa.

Accessions to the Library were reported from the Government Geologist, Adelaide, Australia; Royal Society of N. S. Wales. Hon. Arthur Renwick, Sydney; New Zealand Institute, Wellington; Tokyo Library, Tokyo, Japan; Madras Observatory, Madras, India; R. Asiatic Society (China Branch), Shanghai, China; Societatea Geografica Romăna, Bucuresci; Societates pro Fauna et Flora Fennica, Helsingfors, Finland; Société Physico Mathématique, Kasan, Russia; K. Mineralogische Gesellschaft, Comité Géologique, Bibliothèque Géologique, Société de Géographie, Prof. Serge Nikitin, St. Petersburg, Russia; K. Norsk. Oldskrift Selskab, K. Danske Videns-Rabernes Selskab, Copenhagen, Denmark; Bataviaasch Genootschap van Kunsten en Wetenschappen; Friesch Genootschap van Geschied, etc., Leewarden, Friesland; Musée Teyler, Haarlem, Holland; Academie R. de Belgique, Société R. Malacologique de Belgique, Bruxelles; Naturforschende Verein, Brünn, Austria; K. K. Sternwarte, Prag, Bohemia; I. R. Accademia degli Agiati, Roveredo, Tyrol; K. P.

Geologische Landesanstalt und Bergakademie, Berlin, Prussia; Verein für Schlesische Insektenkunde, Breslau, Prussia; Sächsische Meteorologische Institut, Chemnitz, Saxony; Naturwissenschaftliche Gesellschaft "Isis," Verein für Erdkunde, Dresden, Saxony; K. Gesellschaft der Wissenschaften, Göttingen, Prussia; Wetterauische Gesellschaft für die Gesamte Naturkunde, Hanau a.-M.; Gesellschaft zur Beförderung der gesammten Naturwissenschaften, Marburg, Prussia; Bayerische Botanische Gesellschaft, Munich, Bavaria; Dr. P. Steiner, Neuwied, Germany; Naturwissenschaftliche Verein, Osnabrück, Prussia; Verein für Vaterländische Naturkunde in Württemberg, Stuttgart; Commission Internationale de la carte Geologique d'Europe, Prof. E. Renevier, Lausanne, Switzerland; Société Neuchâteloise de Geographie, Neuchâtel, Switzerland; R. Accademia di Scienze, etc., Modena, Italy; Accademia dei Lincei, Prof. Guiseppi Sergi, Rome, Italy; Société Linnéene, Bordeaux, France; Société Languedocienne de Géographie, Montpellier, France; Prof. Dr. Jules Oppert, Paris, France; Société de Géographie, Lisbon, Portugal; Philosophical Society, University Library, Cambridge, England; Royal Polytechnic Society, Cornwall, England; Philosophical and Library Society, Leeds, England; Zoölogical Society, Meteorological Office, Linnean Society London, England; Natural History and Antiquarian Society, Penzance, England; Université Laval, Quebec, Canada; Nova Scotia Institute of Science, Halifax; Agricultural Experiment Station, Bangor, Me.; Massachusetts Institute of Technology, American Philological Association, Massachusetts Historical Society, Capt. J. W. Norcross, Miss Cornelius Horsford, Boston, Mass.; Astronomical Observatory of Harvard College, Museum of Comparative Zoölogy, Cambridge, Mass.; Essex Institute, Salem, Mass.; Rhode Island Historical Society, Providence; Connecticut Historical Society, Hartford; Yale University, American Oriental Society, New Haven, Conn.; Albany Institute, Albany, N. Y.; Buffalo Library, Buffalo, N. Y.; Hamilton College, Clinton, N. Y.; Academy of Sciences, Meteorological Observatory, American Geographical Society,

Profs. J. A. Allen, Isaac H. Hall, Mr. Cortlandt F. Bishop, New York, N. Y.; Mr. William John Potts, Camden, N. J.; Free Public Library, Jersey City, N. J.; American Chemical Society, Easton, Pa.; Pennsylvania State Weather Service, Zoölogical Society, Pennsylvania Hospital, Prof. George F. Barker, Dr. D. G. Brinton, Prof. E. D. Cope, Messrs. Herbert Welsh, Joseph Wilcox, Philadelphia; Peabody Institute, Baltimore, Md.; Departments of Labor, Agriculture, U. S. National Museum, Messrs. J. W. Fewkes, Lester F. Ward, Washington, D. C.; Leander McCormick Observatory, Charlottesville, Va.; Virginia Historical Society, Richmond; Agricultural Experiment Station, Raleigh, N. C.; Col. Charles C. Jones, Augusta, Ga.; Geological Survey of Arkansas, Little Rock; Agricultural Experiment Station, Knoxville, Tenn.; Geological Survey of Texas, Austin; University of California, Berkeley; Mercantile Library Association, San Francisco, Cal.; University of Cincinnati; Archæological and Historical Society, Columbus, O.; Academy of Natural Sciences, Davenport, Ia.; Washburn College, Topeka, Kans.; Observatorio Astronomico N. de Tacubaya, Chapultepec, Mex.; Direccion Général de Estadística, Mexico, Mex.; Direccion General de Estadística, Guatemala, C. A.; Observatoria N. Arjentino, Buenos Aires, S. A.; Museo Nacional, Santiago de Chile, S. A.

The following donations to the Cabinet were received:

A photo-lithographic copy of the certificate of membership of the American Philosophical Society of Robert Strettle Jones, presented by his grandson, Robert J. Fisher, Washington, D. C.

A phototype (framed) of the old "Liberty Bell," presented by Mr. F. Gutekunst, Philadelphia.

Photographs for the Society's Album were received from Dr. Isaac H. Hall, New York; Mr. Henry C. Baird, Dr. Charles A. Oliver, Philadelphia; Dr. F. A. Muhlenberg, Reading, Pa.

The following deaths were announced:

Anthony J. Drexel (Philadelphia), died June 30, 1893, æt. 60.

Col. C. C. Jones (Augusta, Ga.), died July 19, 1893, æt. 62.

Robert Cornelius (Philadelphia), died August 10, 1893, æt. 84.

Prof. William H. C. Bartlett (Yonkers, N.Y.), died May 11, 1893.

The President was authorized to appoint a suitable person to prepare the usual obituary notice of Mr. Cornelius.

List of deficiencies, part third, was laid before the Society.

The University of Missouri wrote that its Library had been destroyed by fire, and requesting that certain of the Society's Proceedings should be replaced.

On motion the matter was referred to the Librarian with power to act.

And the Society was adjourned by the presiding member.

Stated Meeting, September 15, 1893.

Prof. ALBERT H. SMYTH in the Chair.

Letters of acknowledgment were received from the Observatoire Phys. Central de Russie, St. Petersburg (139); Taschkent Observatory, Taschkent, Turkestan (139); Societas pro Fauna et Flora Fennica, Helsingfors, Finland (136-138); K. Norske Videnskabernes Selskab, Throndhjem, Norway (139); K. Universitetet, Lund, Sweden (139); K. Svenska Vetenskaps Akademien, Stockholm, Sweden (140); Société Royale de Géographie, Antwerp, Belgium (139); K. Zoologisch Genootschap "Natura Artis Magistra," Amsterdam, Netherlands (140); Colonial Museum, Fondation de P. Teyler vander Hulst, Harlem, Holland (139, 140); K. Bibliotheek, The Hague, Holland (139, 140); K. K. Sternwarte, Prag, Bohemia (139, 140); Anthropologische Gesellschaft (137, 138); K. K. Central Anstalt für Meteorologie und Erdmagnetismus (140); Profs. Friederich Müller (140), Gustav Tschermak (136-139), Vienna, Austria; K. Preuss. Geol. Landesanstalt und Bergakademie,

Berlin (140); Verein für Schlesische Insektenkunde, Breslau, Prussia (139); Verein für Geographie u. Statistik, Frankfurt a.-M. (138, 139); Geographische Gesellschaft, Hannover, Prussia (139); K. Sächsische Gesellschaft der Wissenschaften, Prof. J. Victor Carus, Leipzig, Saxony (139, 140); Verein der Freunde der Naturgeschichte, Mecklenburg, Germany (139); K. Sternwarte, Munich, Bavaria (140); Verein für Vaterländische Naturkunde in Württemberg, Stuttgart (136-139, and Trans., xvii, 1, 2); Prof. Carl Vogt, Geneva, Switzerland (140); Biblioteca N. C., Florence, Italy (139); R. Accademia dei Lincei (140); Prof. G. Sergi, Rome, Italy (139, 140); Osservatorio Astronomico, Académie R. des Sciences, Turin, Italy (139); Société d'Émulation, Abbeville, France (140); Société Linnéenne, Bordeaux, France (140); Société d'Anthropologie (135, 138, 139), Ministère des Travaux Publics (140), Marquis de Nadaillac, Profs. Hovelacque, Moscart, Mospero, Paris, France (140); University Library, Prof. J. P. Postgate, Cambridge, England (140); Philosophical and Literary Society, Leeds, England (140); Royal Society, Victoria Institute, R. Meteorological Society, Society of Antiquaries, R. Geographical Society, Linnean Society, Mr. C. Juhlin Dannfeld, London, England (140); Literary and Philosophical Society, Manchester, England (140); Natural History Society, Newcastle-upon-Tyne, England (140); Radcliffe Observatory, Sir H. W. Acland, Oxford, England (140); Royal Society of Edinburgh, Scotland (140); Mr. Horatio Hale, Clinton, Ontario, Canada (140); New York State Library, Albany (135-140); Geological Society of America, Rochester, N. Y. (140); Prof. George Stuart, Philadelphia (136, 137, 139); Dr. W. H. Appleton, Swarthmore, Pa. (137-140); Philosophical Society, Washington, D. C. (140); State Agricultural College, Michigan (139, 140); Kansas State Agricultural College, Manhattan (139); Bishop Crescencio Carrillo, Mérida de Yucatan, Mexico (139, 140); Central Meteorological Observatory, Mexico (140).

Letters of acknowledgment (141) were received from the Geological Survey of Canada, Ottawa; Historical and Scientific Society, Winnipeg, Manitoba; Bowdoin College, Bruns-

wick, Me.; Maine Historical Society, Society of Natural History, Portland, Me.; Prof. C. H. Hitchcock, Hanover, N. H.; Vermont Historical Society, Montpelier; State Library of Massachusetts, Boston Society of Natural History, Massachusetts Historical Society, Athenaeum, Marine Biological Laboratory, Prof. T. M. Drown, Mr. Robert C. Winthrop, Boston, Mass.; Harvard College, Museum of Comparative Zoölogy, Profs. A. Agassiz, G. L. Goodale, Mr. Robert N. Toppan, Cambridge, Mass.; Free Public Library, New Bedford, Mass.; Essex Institute, Salem, Mass.; Prof. Elihu Thomson, Swampscott, Mass.; Ames Antiquarian Society, Worcester, Mass.; Agricultural Experiment Station, Kingston, R. I.; Providence Franklin Society, Rhode Island Historical Society, Providence; Connecticut Historical Society, Hartford; Yale University, New Haven Colony Historical Society, New Haven, Conn.; Agricultural Experiment Station, Storrs, Conn.; New York State Library, Albany, N. Y.; Society of Natural Science, Buffalo, N. Y.; Prof. Edward North, Clinton, N. Y.; Profs. J. M. Hart, J. W. Oliver, B. G. Wilder, Ithaca, N. Y.; Meteorological Observatory, Ames Museum Natural History, Ames Geographical Society, Historical Society, Profs. Isaac H. Hall, John J. Stevenson, New York; Vassar Brothers' Institute, Poughkeepsie, N. Y.; Geological Society of America, Rochester, N. Y.; Prof. W. Le Conte Stevens, Troy, N. Y.; Oneida Historical Society, Utica, N. Y.; Free Public Library, Jersey City, N. J.; Historical Society, Newark, N. J.; Prof. Charles A. Young, Princeton, N. J.; Prof. H. D. Gregory, Philadelphia; Agricultural Experiment Station, Newark, Del.

Donations to the Library were announced.

Mr. W. P. Tatham presented to the Society, on the behalf of Mrs. Mifflin Wistar, a handsomely bound collection of letters to the late Dr. Caspar Wistar, accompanied by the following letter:

TO THE PRESIDENT AND MANAGERS OF
THE AMERICAN PHILOSOPHICAL SOCIETY.

Gentlemen:—The Manuscripts described in the accompanying list have

been selected from the papers of Prof. Caspar Wistar, M.D., who was the fourth President of your ancient and honorable Society.

Among them are letters in English, in French, in German, and in Latin, from some of the most learned men of science of their day. The direct information that they convey may be of little value; it is not from writings of the early years of this century that we look for scientific instruction. But some of the letters are from men so eminent, that they cannot fail to be of interest both in what they tell us of their authors, and in the history of scientific discovery. And the fact that Dr. Wistar's talents were so honored, and his friendship so valued by great and learned men in distant countries, at a period in our history when America attracted little attention among the nations of the earth, will perhaps be gratifying to his successors in this Society, and to American scholars in general.

I beg of you to accept these letters as a memorial of Prof. Wistar's son, my late husband, Dr. Mifflin Wistar, who inherited a love of his profession and a love of his fellow-men, and who died in 1872. No descendant of Prof. Wistar now survives.

I am, gentlemen, most respectfully yours,

ESTHER F. WISTAR.

September, 1893.

*The following is a catalog of the letters, etc., presented:

1. Geneva, July 19, 1794. Letter from Dr. Sylvestre to Dr. Caspar Wistar. (French.)
2. Charleston, May 20, 1796. De Beauvoir to Dr. Wistar, proposing a scientific journey in Georgia.
3. Richmond, April 25, 1798. Same to same, describing the discovery of a skeleton of an elk in Virginia. (French.)
4. North Carolina, May 13, 1797. Letter from Rev. Samuel Spring and Samuel McCorkle to Robert Patterson.
5. New York, February 14, 1792. From Dr. Samuel L. Mitchell to Dr. Wistar, describing a new invention of distilling fresh water from salt.
6. New York, June 30, 1798. Same to Jonathan Williams, describing geological discoveries in New York.
7. Boston, October 12, 1799. Notice of Dr. Wistar's election to the Historical Society of Massachusetts.
8. Paris, April 3, 1801. Printed Prospectus of a work of G. Cuvier, on Quadrupeds, received by the American Philosophical Society from the author.
9. Washington, Mississippi Territory, August 24, 1803. Letter from Samuel Brown to Thomas Jefferson, President of the United States, describing discovery of large bones.
10. Paris, November 15, 1807. Letter from Dr. Delile to Dr. Wistar, relating to poison of the Upas Tree. (French.)
11. Paris, November 21, 1808. Same to same, informing Dr. Wistar that the writer is engaged in a work on the Flora of Egypt, at the Government's expense. (French.)
12. Dissertation on Upas poison, referred to in No. 10. (French.)
13. Paris, October 21, 1809. Letter from Dr. Delile to Dr. Wistar, sending the said dissertation. (French.)
14. Paris, September 14, 1810. Same to same. (French.)
15. Paris, October 10, 1808. Report of G. Cuvier to the Institut National, Classe des Sciences, Physiques et Mathematiques, on a collection of fossils sent by Jefferson. (French.)
16. Paris, November 14, 1808. Letter of thanks for the above from Cuvier to Jefferson. (French.)

On motion, the sincere thanks of the Society were tendered to Mrs. Milflin Wistar for her valuable gift, for which the Society ordered suitable acknowledgment should be made.

The deaths of Edward Hopper, August 7, 1893, æt. 82, and John M. Maisch, September 10, 1893, æt. 63, were announced, and the President authorized to appoint suitable persons to prepare the usual obituary notices.*

Mr. Lyman read a paper on "The Great Mesozoic Fault in

17. Paris, May 27, 1809. Letter from Andre Michaux to Dr. Wistar, referring among other things to his work. (French.)

18. Paris, November 29, 1809. Same to same. (French.)

19. Paris, September 7, 1810. Same to same, introducing Monsieur Borges. (French.)

20. Paris, December 5, 1811. Same to same, introducing the Abbe de Correa de Serra. (French.)

21. Paris, January 28, 1812. Same to same. (French.)

22. Paris, June 26, 1814. Same to same. (French.)

23. Paris, September 17, 1816. Same to same. (French.)

24. Paris, December 18, 1817. Same to same. (French.)

25. No date. Same to same. (French.)

26. No date. Same to same, sending the first volume of Michaux's book on the trees of the United States.

27. No date. Instructions from the American Philosophical Society to Mr. Andrew Michaux, for exploring the country along the Missouri and thence westwardly to the Pacific Ocean.

28. Francker (Holland), July 31, 1809. Letter from A. G. Camper about fossils collected by his father, the late Professor of Anatomy, Pitrus Camper.

29. Francker, November 10, 1809. From same to Dr. Wistar, about same, etc.

30. Francker, June 2, 1815. From same about same, etc.

31. Francker, June 20, 1816. From same to Dr. Wistar, about an alligator skeleton, etc.

32. Paris, December 4, 1811. From D. B. Warden to Dr. Wistar, introducing Correa de Serra.

33. Boston, September 27, 1813. From I. Correa de Serra to Dr. Wistar.

34. Lexington, August 20, 1814. From same to same.

35. St. Petersburg, October, 1813. From Dr. Tilesius to Dr. Wistar, about skeletons, etc. (Latin.)

36. St. Petersburg, October, 1813. From same to same, about fossils, skeletons, etc.

37. St. Petersburg, January 27, 1814. From same to same, accompanying a box of casts of skulls, bones, etc. (German.)

38. New York, May 1, 1815. Notice of Dr. Wistar's election as an honorary member of the New York Literary and Philosophical Society.

39. Bethlehem, June 2, 1816. Letter from John Heckewelder to Dr. Wistar, about the publication of a book, etc.

40. Bethlehem, July 1, 1816. From same to same, about said book.

41. Bethlehem, April 26, 1817. From same to same.

42. March 3, 1815. Report of the Committee on Dr. Wistar's Memoir on the Othmoid Bone.

43. January 19. —. Report of the Committee on Dr. Wistar's Paper on Fossil Bones.

44. Philadelphia, July 22, 1830. Letter from the President of the American Philosophical Society, asking for the loan of Dr. Wistar's portrait in order to have it copied and hung in the Hall of the Society.

* The President subsequently appointed Dr. Charles S. Dolley for Dr. Maisch.

New Jersey," after the conclusion of which the author, in answer to a query by Mr. Williams as to whether he could suggest any other name for the Newark group, stated that Montgomery shales would be more suitable, because the beds occur more fully and have been studied more thoroughly in Montgomery county (Pennsylvania) than in any other like district; but that the beds are probably of two various ages to be properly called by a single name.

New nominations Nos. 1260, 1261, 1262, 1263, 1264 were read.

Mr. Williams moved "that a Committee of five members be appointed to consider a plan for preparing a Coöperative Index of all Transactions."

After discussion, the motion was deferred until the next meeting of the Society, notice of same to be placed on the card, and the Society was adjourned by the presiding member.

Stated Meeting, October 6, 1893.

President FRALEY in the Chair.

Correspondence was submitted as follows:

A letter from Hon. Charles P. Daly, New York, accepting membership.

A letter from the Naturhistorische Verein der Preussischen Rheinlande, Westfalens und des Regierungs-Bezirks Osnabrück, Bonn, Prussia, inviting the Society to attend the celebration of its Fiftieth Anniversary, held May 23 and 24, 1893.

A letter from the Niederrheinische Gesellschaft für Natur- und Heilkunde, Bonn, Prussia, inviting the Society to attend the celebration of its Seventy-fifth Anniversary, held July 2, 1893.

Letters of envoy were received from the K. Akademie der Wissenschaften, Vienna, Austria; Naturforschende Gesellschaft, Bamberg, Bavaria; K. Geologische Landesanstalt und

Bergakademie, K. P. Meteorologische Institut, Berlin, Prussia; Verein für Schlesische Insektenkunde, Breslau, Prussia; K. Sächsische Gesellschaft der Wissenschaften, Leipzig, Saxony; Verein für Vaterländische Naturkunde, Stuttgart, Württemberg; Société des Sciences Physiques et Naturelles, Bordeaux, France; Musée Guimet, Paris, France; Smithsonian Institution, Washington, D. C.; Mr. William John Potts, Camden, N. J.; Academy of Natural Sciences, Davenport, Iowa; Dirección General de Estadística de la República Mexicana, Mexico.

Letters of acknowledgment were received from the Royal Society of Victoria, Melbourne (139); Royal Society of N. S. Wales, Sydney, Australia (139); K. Vetenskaps Akademiens, Stockholm, Sweden (141); Royal Society of Sciences, Upsal, Sweden (140); K. Danske Videnskabernes Selskab, Prof. Japetus Steenstrup, Copenhagen, Denmark (139, 140); Royal Zoölogical Society, Amsterdam, Netherlands (139); K. Zoolisch-Botanische Genootschap, The Hague, Z. Holland (139, 140); Imperial Academy of Science, St. Petersburg, Russia (139); K. K. Naturhistorische Hofmuseum, Drs. Aristides Brezina, Friederich S. Krauss, Matthæus Much, Vienna, Austria (140); Naturforschende Gesellschaft des Osterlandes, Altenberg, Saxe-Weimar (140); Deutsche Geologische Gesellschaft (139, 140), Editor of *Naturwissenschaftliche Wochenschrift* (140), Gesellschaft für Erdkunde (140), Berlin, Prussia; Verein für Erdkunde, Dresden, Saxony (140); Physikalisch-Medicinische Societät, Erlangen, Bavaria (139, 140); Oberhessische Gessellschaft für Natur- und Heilkunde, Giessen, Hesse (139, 140); Physikalisch-(Ökonomische Gesellschaft, Königsberg, Prussia (139); Verein für Erdkunde, Metz, Lorraine (139, 140); Instituto di Studi Superiori, Firenze, Italia (140); R. Osservatorio dell' Università, Torino, Italia (140); Académie des Sciences et Belles-lettres, Angers, France (139); Société Historique du Cher, Bourges, France (139); Société des Sciences Naturelles et Archéologiques de la Creuse, Guéret, France (139); Prof. León de Rosny, Paris, France (139); Mr. Samuel Timmins, Arley, Coventry, England (141); Bath

and West and Southern Counties Society, Bath, England (140, 141); Royal Meteorological Society (141), Victoria Institute (141), Linnean Society (141), Royal Astronomical Society (141, and *Trans.*, xvii, 3, xviii, 1), Prof. William Crookes (141), Mr. C. Juhlin-Dannfelt (141), Dr. W. H. Flower (140), London, England; Literary and Philosophical Society, Geographical Society, Manchester, England (141); Royal Observatory, Edinburgh, Scotland (141, and *Trans.*, xvii, 3, xviii, 1); Massachusetts Agricultural College, Amherst (141), Dr. Justin Winsor, Cambridge, Mass. (137-140); Prof. James Hall, Albany, N. Y. (141); American Geographical Society, Prof. Isaac H. Hall, New York (137-140); Prof. C. W. Shields, Princeton, N. J. (141); Wyoming Historical and Geological Society, Wilkesbarre, Pa. (141); State Library of Pennsylvania, Harrisburg, Pa. (*Trans.*, xvii, 3, xviii, 1); Mercantile Library (141), Prof. E. D. Cope (141), Mr. E. T. D'Invilliers (137-140), Mr. G. de B. Keim (141), Prof. Albert H. Smyth (141), Prof. George Stuart (135, 141), Philadelphia; Prof. James E. Rhoads, Bryn Mawr (137-141); Agricultural Experiment Station, Newark, Del. (139, 140); U. S. Naval Institute, Annapolis, Md. (141); Maryland Institute, Enoch Pratt Free Library, Baltimore, Md. (141); Mr. T. L. Patterson, Cumberland, Md. (141); Smithsonian Institution (544 packages), Bureau of Ethnology, Surgeon-General's Office, U. S. Weather Bureau (*Trans.*, xvii, 3, xviii, 1), Anthropological Society, U. S. Coast and Geodetic Survey, U. S. Geological Survey, Col. Garrick Mallery, Rt. Rev. John J. Keane, Profs. S. F. Emmons, Charles A. Schott, Drs. J. S. Billings, Albert S. Gatschet, W. J. Hoffmann, Mr. W. B. Taylor, Washington, D.C. (141); University of Virginia, Leander McCormick Observatory, Charlottesville, Va. (141); U. S. Artillery, Fort Monroe, Va. (141); Prof. J. W. Mallet, University of Virginia, Va. (141); N. C. Experiment Station, Raleigh (141); Canebrake Experiment Station, Uniontown, Ala. (141); University of Alabama, University P. O. (141); State Experiment Station, Baton Rouge, La. (141); Academy of Sciences, Austin, Texas (141); Society of Natural History, Prof. T. H.

Norton, Cincinnati, Ohio (141); Oberlin College, Oberlin, O. (141); Agricultural Experiment Station, Knoxville, Tenn. (141); Purdue Experiment Station, LaFayette, Ind. (141); State Agricultural College, Michigan (141); Academy of Natural Sciences, Davenport, Ia. (141); Washburn College, Topeka, Kans. (141); State Historical Society, Madison, Wis. (141); Colorado Scientific Society, Denver (141); State Agricultural College, Fort Collins, Colo. (137, 139, 140, 141); Academy of Science, Tacoma, Wash. (141); Experiment Station, Lincoln, Neb. (141); University of California, Prof. Joseph LeConte, Berkeley, Cal. (141); Prof. J. C. Branner, Palo Alto, Cal. (141); Prof. Daniel Kirkwood, Riverside, Cal. (141); Prof. George Davidson, San Francisco, Cal. (141); Observatorio Astronomico de Tacubaya, Mexico (141); Bishop Crescencio Carrillo, Merida, Yucatan, Mex. (141).

Accessions to the Library were reported from the K. K. Militär-Geographische Institut, Vienna, Austria; Naturforschende Gesellschaft, Bamberg, Bavaria; K. P. Meteorologische Institut, Berlin, Prussia; Verein für Erdkunde, Cassel, Prussia; Naturforschende Gesellschaft, Emden, Prussia; Oberhessische Gesellschaft für Natur- und Heilkunde, Giessen, Hesse; Geographische Gesellschaft, Hanover, Prussia; Physikalisch-Ökonomische Gesellschaft, Königsberg, Prussia; Verein für Kunst und Alterthum, Ulm, Württemberg; Société des Sciences Physiques et Naturelles, Bordeaux, France; Académie N. des Sciences, etc., Caen, France; Société de l'Histoire de France, Prof. Paul Topinard, Paris, France; Société d'Agriculture, Lyons, France; Instituto y Observatorio de Marina, San Fernando, Spain; Société de Géographie, Lisbon, Portugal; Rousdon Observatory, Devon, England; Department of Public Works and Mining, Halifax, N. S.; Natural History Society, Montreal, Canada; Royal Society of Canada, Ottawa; Massachusetts Institute of Technology, Boston, Mass.; Scientific Alliance, Prof. J. A. Allen, New York, N. Y.; Mr. Henry Phillips, Jr., Philadelphia; Smithsonian Institution, Anthropological Society, Dr. Elliott Coues, Washington, D. C.; Georgia Historical Society, Savannah; Public Library, St.

Louis, Mo.; Michigan Mining School, Lansing; University of Wisconsin, Madison; Mr. Alton H. Thompson, Topeka, Kans.; Nebraska State Historical Society, Lincoln; Colorado Scientific Society, Denver; Agricultural Experiment Stations, Kingston, R. I., Madison, Wis.

A photograph for the Society's album was received from Mr. Robert P. Field, Philadelphia.

A circular from the Friesch Genootschap voor Geschied-, Ondheid en Taalkunde, Leeuwarden, Friesland, announcing the death of three of its members.

The Secretaries reported that the paper by Prof. Gentry was undesirable for publication, and it was ordered to be returned to its writer.

Dr. Ruschenberger read an obituary notice of the late William Barton Rogers.

Prof. W. B. Scott, of Princeton, N. J., presented a paper for the Transactions entitled, "On the Mammalian Fauna from the Deep River Beds of Montana," of which he gave an oral synopsis.

On motion, the President was authorized to appoint a Committee of three members to examine and report on same.*

Dr. Brinton read a paper on "The Central American Native Calendar."

In answer to a query by Dr. Morris, Dr. Brinton made some remarks on the meaning of the Mexican Calendar.

Pending nominations Nos. 1260, 1261, 1262, 1263 and 1264 were read.

At the call of deferred business, the motion of Mr. Williams, offered at the last meeting, was taken up and considered. The motion was as follows:

Resolved, That a Committee of five members be appointed to consider a plan for preparing a Coöperative Index of all Transactions."

The subject was discussed by Messrs. Smyth, Brinton, Cope, Prime, Phillips, Morris and others, and was explained by Mr. Williams.

* Dr. Cope, Dr. Ryder and Mr. Lyman were subsequently appointed as such Committee.

Dr. Horn moved to amend the resolution so that it should read as follows: "*Resolved*, That a Committee of five members be appointed to consider the expediency of preparing a plan of a Coöperative Index of all Transactions and if expedient to report such a plan to the Society."

Mr. Williams accepted the amendment.

The question was put on the motion as amended and the resolution was carried by a vote of seven ayes to six nays.

And the Society was adjourned by the President.

Stated Meeting, October 20, 1893.

President, Mr. FRALEY, in the Chair.

Dr. James E. Rhoads, of Bryn Mawr, was presented to the Chair and took his seat.

Accessions to the Library were reported from the Government Geologist, Adelaide, Australia; R. Societatis Scientiarum, Upsal, Sweden; Naturwissenschaften Verein des Reg.-Bez. Frankfurt a. O., Prussia; Direzione Generale della Statistica, Rome, Italy; R. Accademia de Scienze, R. Osservatorio Astronomico, Turin, Italy; Union Géographique du Nord de la France, Douai; Société de Géographie, Paris, France; Geological Survey of Canada, Ottawa; Historical and Scientific Society of Manitoba, Winnipeg; Vassar Brothers' Institute, Poughkeepsie, N. Y.; Ferry Co., Hoboken, N. J.; Mr. Henry Phillips, Jr., Philadelphia; Board of Public Charities, etc., Harrisburg, Pa.; Surgeon-General's Office, Bureau of American Republics, Dr. Albert S. Gatschet, Washington, D. C.; Public Library, Cincinnati, O.; Iowa Geological Survey, Des Moines; Department de Fomento, Caracas, Venezuela.

Letters of envoy were received from the Société Royale des

Sciences, Upsal, Sweden; Académie R. des Sciences, etc., Bruxelles, Belgium; Geological Survey of Canada, Ottawa; Bureau of American Republics, Washington, D. C.

Letters of acknowledgment were received from the Royal Geographical Society (Queensland Branch), Brisbane (139); Société Royale des Sciences, Upsal, Sweden (125-139); K. Zoologisch Genootschap, Amsterdam, Netherlands (141); Fondation de P. Teyler van der Hulst, Colonial Museum, Haarlem, Holland (141); Museum van Oudheiden, Leiden, Holland (141); Royal Library, K. Zoologisch-Botanisch Genootschap, 'S-Gravenhage, The Hague (141); Académie R. des Sciences, etc., Bruxelles, Belgium (139); K. K. Central-Anstalt für Meteorologie, etc., Vienna, Austria (141); Naturhistorische Verein, Bonn, Prussia (139); Naturwissenschaftliche Verein des Reg.-Bez. Frankfurt a. O., Prussia (137, 139, 140); Direktion der Deutsche Seewarte, Hamburg, Germany (140); K. Sternwarte, Munich, Bavaria (141); Marquis Antonio de Gregorio, Palermo, Italy (139, 140); Philosophical Society, Cambridge, England (141, and Trans., xvii, 3, xviii, 1); Royal Geographical Society, Zoölogical Society, Dr. W. H. Flower, Mr. P. L. Selater, London, England (141); Prof. W. Boyd Dawkins, Manchester, England (139, 140, 141); Natural History Society, New-Castle-on-Tyne, England (141); Royal Society, Dublin, Ireland (141); Prof. W. D. Whitney, New Haven, Conn. (141); Prof. L. B. Hall, Haverford, Pa. (141); Dr. John H. Brinton, Philadelphia (141); Smithsonian Institution, Washington, D. C. (141); University of Michigan, Ann Arbor, Mich. (141); Prof. E. W. Claypole, Akron, O. (141); Cincinnati Observatory (141); Prof. H. S. Osborn, Oxford, O. (141); Prof. J. L. Campbell, Crawfordsville, Ind. (141); Mr. Everard F. im Thurn, Georgetown, British Guiana, South America (140); Bureau de Statistique, La Plata, Buénos Ayres, South America (96, 107-128, 135-138).

The Committee on Prof. W. B. Scott's Paper reported the same to be worthy of publication in the Transactions of the Society.

On motion, the Committee was discharged.

Pending nominations Nos. 1260, 1261, 1262, 1263 and 1264 were read, spoken to and balloted for.

Mr. Prime made some remarks on the classification of ore deposits and proposed a new system.

Dr. Cope made an oral communication on the forms of fossil sharks, family Cladodontidæ.

The President reported the appointment of Mr. William P. Tatham on the Committee of Finance in place of W. B. Rogers, deceased.

The business of the meeting being over, the Tellers examined the ballots cast and reported to the President the state of the poll.

The President thereupon declared that the following had been duly elected to membership in the Society :

2222. Dr. Samuel A. Green, Boston, Mass.

2223. Dr. John G. Morris, Baltimore, Md.

2224. Prof. J. M. Hoppin, New Haven, Conn.

2225. Chevalier Rousseau d'Hoppancourt, Vienna, Austria.

2226. Dr. Isaac Roberts, London, England.

And the Society was adjourned by the President.

A Notice of William Barton Rogers.

By W. S. W. Ruschenberger, M.D.

(Read before the American Philosophical Society, Oct. 6, 1893.)

According to its long-existing practice on the death of a member, the Society, at the proper time, resolved that a notice of the late William B. Rogers should be recorded in its *Proceedings*, and that the President should appoint a member to prepare it. He has been pleased to kindly assign the duty to me. And now, with diffidence, I submit the following brief sketch.

Mr. Rogers was a son of Dr. James Blythe Rogers, who succeeded

the distinguished chemist, Dr. Robert Hare, in the Professorship of Chemistry in the University of Pennsylvania. His three uncles, as well as their father, Dr. P. K. Rogers, were widely known in the field of science. Dr. P. K. Rogers was appointed, in 1819, Professor of Natural Philosophy and Mathematics in the ancient college of William and Mary, at Williamsburg, Va. William B. Rogers, the uncle after whom our subject was named, was Professor of Natural Philosophy and Geology in the University of Virginia, and, from July, 1835, the Director of the Geological Survey of the State. Henry Darwin Rogers was Director of the First Geological Survey of Pennsylvania, and, from 1858, Regius Professor of Natural History in the University of Glasgow; and Dr. Robert E. Rogers was Professor of Chemistry during many years in the University of Pennsylvania, and subsequently in the Jefferson Medical College.

William B. Rogers, Jr., was born Dec. 17, 1833, in Baltimore, where his parents then resided. In 1840, they settled in Philadelphia. William was first at a Friends' School, taught by Miss Mary Tyson. On leaving it, he was, from 1843 to 1846, at the Public Grammar School, N.E. corner of Twelfth and Locust streets, of which Mr. Clevenger was Principal.

In 1846, he entered the Central High School of Philadelphia, then under the direction of Mr. John S. Hart, and graduated Bachelor of Arts in 1850. The same year he matriculated at the University of Virginia, but being called home in the spring of 1852 by the illness of his father, who died June 15, he did not resume his course in the University.

In the winter of 1852-53, he was appointed an assistant on the First Geological Survey of Pennsylvania, and for three years did field or office duty, as occasion required, and in the fourth year, desultory work. This Geological Survey was ended by the failure of the Legislature of the State to appropriate money to continue it, and all who had assisted in the work were released from their connection with it.

Mr. Rogers was without regular occupation during many months. To him profitable and continued employment of some kind was very desirable. He was always an earnest student, and his acquirements were notable at that time. It seemed probable that the example of the lives of his father and uncles, as well as his own preference, would induce him to select for himself only some one of

the vocations associated with science. Possibly, however, observation may have satisfied him that toiling on any purely scientific path does not always lead to sufficient compensation, reckoned either in fortune or in fame. Whatever reason may have determined his course, he abandoned science as a career, but adhered to it as a proper diversion and amusement for leisure hours.*

In December, 1859, The Western Saving Fund Society of Philadelphia appointed him a clerk in the institution. There his habitual exactness, devotion to duty, pleasant demeanor, and manifest integrity in every sense won for him unreserved confidence and esteem, and secured his advancement step by step in the institution. In July, 1862, he was promoted to be Secretary and assistant of the President.

He married, Nov. 12, 1862, a daughter of Mr. William Wynne Wister, of Germantown, and in December of that year was appointed Treasurer of the Saving Fund. He was chosen Vice-President of it in February, 1878, and elected one of the Board of Managers of the Society in October, 1882.

To obtain temporary relaxation from official duty after almost continuous attention to it during thirty-one years, and also for the benefit of his health, which was in some degree impaired, he went to Europe in June, 1890; and, having visited the British Islands, Belgium, France, Germany and Switzerland, returned and resumed his official work, after an absence of about three months.

His educational training and impressions, received while in view of near relatives engaged in scientific work, possibly imparted the taste which led him to seek temporary diversion from cares incident to his vocational occupation in certain societies, devoted to the increase and diffusion of knowledge, as well as to the promotion of general interest in intellectual pursuits. He was interested in several such associations.

Mr. Rogers became a member of the Union League, May 13, 1863, and resigned from it Nov. 13, 1866.

He was a member of the Academy of Natural Sciences of Philadelphia from September, 1870, and was elected one of the Board of Trustees of the Building Fund of the Academy, and Secretary of the Board in January, 1893.

* The writer of this notice learned since "reading" it, that Mr. Rogers, about three months before his death, told a friend that the reason why he abandoned science for finance was his inability to obtain any scientific appointment.

He was a member of the Board of Directors of the Mercantile Library Company of Philadelphia from 1878 till 1887, when he resigned.

He was chosen a member of the American Philosophical Society April 16, 1880, and served on its Finance Committee from January, 1885.

He was elected a member of the Historical Society of Pennsylvania, December 19, 1887; and was also a member of the Geographical and of the Photographical Societies.

The titles of the institutions in which Mr. Rogers was interested may suggest the various subjects that, at different times, occupied his attention. Intellectually liberal, generous in disposition, and naturally endowed with a well-balanced mind—good sense—his diversified and reliable knowledge greatly enhanced his qualifications to be an efficient officer and manager in a financial institution.

His general health had become impaired in the past year. After a few hours' illness at his home in Germantown, he died on the evening of March 15, 1893, in the sixtieth year of his age, leaving a widow, a son, and a daughter, bereaved of a considerate, loving husband and affectionate father.

The Western Saving Fund Society of Philadelphia, at a special meeting, March 20, recorded on its minutes an expression of its sense of loss in the death of its Vice-President, who with entire approbation had served the Society during thirty-three years. His extensive knowledge of finance enabled him to judiciously select securities suitable for the investment of funds entrusted to the care of the Society. He had the confidence and respect of depositors; and with those who desired to transact other business with the institution, his relations were always friendly and confidential.

The value of an officer so highly qualified cannot be easily estimated nor definitely expressed. William B. Rogers will long be kindly and respectfully remembered by his daily associates and numerous friends.

Philadelphia, in his death, lost a modest, intelligent, unpretentious citizen, whose conduct was exemplary in every respect—a man who never forgot to do his duty.

*The Native Calendar of Central America and Mexico.**A Study in Linguistics and Symbolism.**By Daniel G. Brinton, M.D.**(Read before the American Philosophical Society, Oct. 6, 1893.)*

1. Purpose and Method of the Inquiry.
2. Geographic Extension of the Calendar System.
3. Mathematical Basis of the Calendar. The 20 and 13-day Periods.
4. The 5-day Periods and "Year-bearers."
5. The 7-day Periods.
6. The Vague Solar Year.
7. Methods of Divination by the Calendar.
8. Calendar Festivals of the Modern Quichés.
9. Where was the Calendar Invented, and by what Nation?
10. The Linguistic Analysis.
11. Analysis of the Day-Names in the Maya, Tzental, Quiché, and Cakchiquel Dialects, and in the Zapotec and Nahuatl Languages.
12. Analysis of the Month-Names in the Maya, Tzental, Quiché, and Cakchiquel Dialects, and in the Chapanec Language.
13. The Symbolism of the Day-Names.
14. General Symbolic Significance of the Calendar.

§ 1. PURPOSE AND METHOD OF THIS INQUIRY.

Of all the intellectual monuments which remain to us of the native race of the Western Continent, the most remarkable without doubt is the Calendar system which was in use among the more civilized tribes of Mexico and Central America. Years ago, Alexander von Humboldt assigned to it the first rank among the proofs that they had reached a certain degree of true civilization; indeed, so deeply did its intricacies impress him, that he could not believe that it was wholly developed by tribes so uncultured in some other respects, and sought for its chief principles an origin among the old civilizations of Asia.*

A profounder study of the subject, rendered possible by more abundant documents, especially of a linguistic character, has shown that the hypothesis of the great naturalist is unnecessary,

* See his *Vues des Cordillères et Monumens des Peuples Indigènes de l'Amérique*, Tome i, p. 332, etc.

and indeed contrary to the evidence. The peculiarities which mark this Calendar belong to itself alone, and differ completely from those on which the time-counts and astronomical measurements of the ancient nations of the Old World were based. It is strangely and absolutely independent and American in its origin and development.

The especial object which I have in view in this essay is to collect the month and day-names of all the nations of the Maya stock within my reach, and subject them to an etymological analysis and comparison with their correspondents in the Zapotec and Nahuatl tongues, and to endeavor to reach the symbolic significance of the Calendar as a mythical record and method of divination.

I confine myself to the linguistic analysis, and avoid that based on the hieroglyphic writing, of which so much use has been made by Prof. Cyrus Thomas, Dr. Schellhas, Dr. Seler and others, because I believe it must be brought into requisition with great caution and under strict limitations. The leading principle of this writing is, in my opinion, essentially phonetic, and not representative; but phonetic according to what I have called the "ikonomatic" method, which means that the glyph or figure is a picture, not of the object, but of the name of the object, as in what is called a "rebus."*

The consequence of this is, that it becomes quite misleading to seek the real meaning or derivation of a day-name or other word from the figure which represents it in the hieroglyphic writing. The latter stands usually for a word of an entirely different meaning, the only connection being a more or less similarity in sound.

This will readily be understood by a few examples of this method of writing in our own tongue. In it, for instance, the pronoun "I" would be represented by the picture of an eye; a (writing) pen by the picture of a (hog) pen; "matron" by a mat, and a person running; and so on.

It is evident that any attempt to derive from such figures the literal names of the day or month would lead the inquirer wholly astray. Yet in spite of the fact that we have any number of examples proving that this method was constantly in use by the

* See my *Essays of an Americanist*, pp. 213-229 (Philadelphia, 1890), for a full explanation of the ikonomatic method.

Nahuas and Mayas, the authors above referred to and others have repeatedly overlooked it, and have often been led into obviously erroneous interpretations.

§ 2. GEOGRAPHIC EXTENSION OF THE CALENDAR SYSTEM.

We know to a certainty that essentially the same Calendar system was in use among the Nahuas of the Valley of Mexico and other tribes of the same linguistic family resident in Tlascallan and Meztitlan, in Soconusco, Guatemala and Nicaragua; that it prevailed among the Mixtecs and Zapotecs; and that of the numerous Mayan tribes, it was familiar to the Mayas proper of Yucatan, the Tzentsals and Zotzils of Chiapas, the Quichés and Cakchiquels of Guatemala, and to their ancestors, the builders of the ruined cities of Copan and Palenque.

There is no direct evidence that it had extended to the Huastecas, of Maya lineage, on the Rio Panuco; but it was in vogue among the Totonacos, their neighbors to the south, on the Gulf of Mexico. The Pirindas, Matlazincas and Tarascos of Michoacan had also accepted it, though perhaps not in a complete form.* The Chapanecs (Chiapanecs) or Mangues, part of whom lived in Nicaragua and part in Chiapas, had also adopted it.

The tribes above named belong to seven entirely different linguistic stocks, but were not geographically distant. Outside of the area which they occupied, no traces of this Calendar system, with its many and salient peculiarities, have been found, either in the New or the Old World.

The date of this wide dispersion we cannot assign, but we can positively say that it was many centuries before the conquest of the country by the Spaniards. We know that in the Mayan territory the builders of the ancient cities of Palenque in Tabasco, and Copan in Honduras, both of which had been deserted and ruined long before the arrival of Cortes, were familiar with a well-developed form of this Calendar, and with the graphic methods for carrying out its computations. We further know that the migrations of the Nahuas from Central Mexico, to form the colonies of the Pipiles in Guatemala, and of the Nicaraos in Nicaragua, took place after that stock had elaborated their special

* On this point, consult the *Anales del Museo Michoacano*, Tomo i (1888), p. 85, for a critical exposition of the question, by the Rev. Paso y Troncoso. Also, Orozco y Berra, *Historia Antigua de Mexico*, Tomo ii, p. 144 *et seq.*

form of the Calendar, because these emigrants carried it with them, and preserved it until the advent of the Europeans. Such facts incline us to accept the statement of the Quiché astronomers to the effect that they had been regularly keeping their national annals by this time measurement for at least eight hundred years before the advent of the Spaniards in 1524.*

The Mayan dialects of which I can avail myself are the Maya proper of Yucatan; the Tzentäl of Chiapas; and the Quiché and Cakchiquel of Guatemala. The last two differ very slightly from each other, and may be considered as one language. The Tzentäls and Zotzils were closely allied branches of the stock, who inhabited a considerable portion of Chiapas and Tabasco when this region was first explored by the Spaniards. Early writers often call the Tzentäls, "Tzendals" and "Zeldals," through a corruption of their proper name, which is Tzentäl, there being no *d* in their alphabet. The Zotzils called themselves Keren, "young men," which the Spaniards changed into Quelenes.

García de Palacio, writing in 1576, includes both under the compound name, Zeldal-Quelen, as one language.† They have from time to time been spoken of erroneously as Chiapanecs. These, whose right name is Chapanecs, are linguistically in no way related to the Mayan stock.

The Tzentäl dialect is not distant from the pure Maya. In his scheme of the divarication of the stock, Dr. Stoll places it, indeed, as the branch nearest allied to the tongue spoken in Yucatan.‡ I am inclined, however, from my own studies of these dialects, to accept as correct the uniform traditions of the Cakchiquels, Quichés and Tzutuhils of Guatemala, who traced their ancestry to the same parentage as that of the Tzentäls and Zotzils; thus bringing the dialects of Chiapas into closer relationship to those of Guatemala than to those of the Peninsula of Yucatan. §

* "Demas de ochocientos años," Herrera, *Historia de las Indias Occidentales*, Dec. iii, Lib. iv, cap. 18.

† *Carta al Rey*, p. 20 (Ed. Squier).

‡ Dr. Otto Stoll, *Ethnographie der Republik Guatemala*, s. 84 (Zurich, 1884). The form "Tzotzil" adopted by this writer is not so correct as "Zotzil."

§ I do not include the Chol among the proper dialects of the Tzentäl territory. It is of modern introduction, from the upper valley of the Usumacinta river.

§ 3. MATHEMATICAL BASIS OF THE CALENDAR.

The general outlines of this Calendar system are so well known—or rather, I should say, are discussed in so many accessible books—that I need not more than refer to them here.

The basis is a so-called “month” of 20 days. Each day is designated by a name of some object, animate or inanimate; and besides its name, each day is numbered, but not from 1 to 20, but only from 1 to 13, when the numbering begins again at the unit.

The result of this combination evidently is, that a day bearing both the same name and the same number will not recur until 13 of the “months” have elapsed. This gives a period or cycle of 260 days, and this anomalous period is at the foundation of the native Calendar.

Why was it chosen? Does it correspond to any series of recurring events in nature? Is it astronomical? Or was it purely mythical and terrestrial?

The answers to these inquiries are not entirely satisfactory. It is generally admitted that the number 20 was chosen because the arithmetical system of these nations was vigesimal, and grouping the days by twenties was a natural method with them; and it has usually been stated that the number 13 represents one-half the number of days during which the moon is visible between its heliacal conjunctions, and that it owed its selection to this observation.*

An obvious difficulty in this theory is, that according to it the Calendar ought not to take note of the days when the moon is in conjunction, as otherwise after the very first month it will no longer correspond with the sequence of natural events from which it is assumed to be derived; but as these days *are* counted, it would appear, although the lunar relations of the calendar in later days cannot be denied, that it had some other origin.

The month may have been counted from new moon to new moon; but the 26 days in which the moon was actually visible alone have been included in a ritual or ceremonial lunar count, 13 of these being assigned to the waxing, 13 to the waning moon.

* See Orozco y Berra, *Historia Antigua de Mexico*, Tome ii, p. 12. Another theory which he suggests is that the 13 may have had reference to the 13 lunar months which approximately make up a solar year.

Dr. Förstemann is of opinion that the 13-day period arose from an effort to divide the vague solar year, counted as 364 days, into equal parts, thus making $13 \times 28 = 364$.*

Another theory, especially urged by the able Mexican antiquary, Paso y Troncoso, is that the period of 260 days and the number 13 owe their selection to astronomical observations of the planet Venus. He points out that 5 synodical revolutions of Venus equal 8 solar years; and that after 13 periods of 8 years, forming a cycle of 104 years, on the initial day of the next cycle the relative positions of Venus and the sun would be the same as at the commencement of the first cycle.†

An entirely different explanation of the selection of the number 13 is that which traces it to certain widespread terrestrial and mythical connections.

Whether these mythical relations were adopted from the Calendar or whether they gave rise to it, they certainly were present in marked prominence among these nations. According to Aztec mythology the heavens were 13 in number, and 13 divinities ruled over the under world. The Quichés and Cakchiquels believed that 13 was the number of the first ancestors of the human race, so they divided their tribes into 13 divisions or gentes. And other instances could be quoted of the sacredness of this number.

Whence did it derive this mythical character?

A possible explanation has been suggested to me by Mr. Frank H. Cushing, based on his observations among the Zuñis.

In the ceremonies of this nation the complete terrestrial sphere is symbolized by pointing or blowing the smoke to the four cardinal points, to the zenith and the nadir, the individual himself making the seventh number. When the celestial is also to be symbolized only the six directions are added to this seven, because the individual remains the same. So that the number typifying the whole universe, terrestrial and celestial, becomes 13.

When, on the other hand, in their ceremonies the rite requires the officiant to typify the supra- and the infra-terrestrial spheres,

* "Die Zahl 364 scheint den Anlass gegeben zu haben das Jahr in Perioden von je 13 Tagen zu teilen. Denn die Natur scheint die Zahl 13 nicht geliefert zu haben." *Globus*, Bd. 63, No. 2. 1892.

† See his lengthy and careful study in the *Anales del Museo Nacional de Mexico*, Tomo ii, pp. 350, *seq.*

that is, the upper and the under worlds, the same number, 13, results, as it is held that in each the sun stands for the individual, being in turn the day-sun and the night-sun, the light and the dark sun, but ever the same, and therefore counts but once.

The number 13 possesses certain properties and relations which appear to have recommended it widely for divinatory purposes and games. The Mexican "cycle" was composed of 52 years arranged in 4 series of 13 each; precisely analogous to a pack of our playing cards. These cards can be traced back to primitive games played for purposes of divination; and no doubt the numbers were selected and combined in both instances from the same motives.

The Nahuas certainly regarded the ritual year of 260 days as equivalent to 9 lunations, as they divided it in some of the most important of their Calendars—the celebrated "Tonalamatl," for instance—into 9 equal divisions, ruled over by the so-called 9 "Lords of the Night;" thus $29 \times 9 = 261$; though what they did with the supernumerary day is not clear.*

An ingenious theory of the mathematical development of this Calendar has been offered by Mrs. Zelia Nuttall. It assumes that at the close of each period of $20 \times 13 = 260$ days, 5 intercalary days were inserted before the next 260-day period was technically commenced. This naturally brought its commencement on the next subsequent Dominical day, and also caused the whole period, 265 days, to equal, very nearly, nine lunations. If it can be shown that this intercalation actually took place, Mrs. Nuttall's suggestion will have cleared up one of the most obscure problems in American archæology.

It seems inherently probable that there was some such very accurate hieratic plan of keeping the time count, as we are assured by many writers that certain native festivals, etc., were observed precisely on days of the year fixed by the European Calendar.†

* On the Tonalamatl see Dr. Selser's very thorough article in the *Compte-Rendu* of the Congress of Americanists for 1888, p. 527, *seq.*

† Dr. Stoll has shown that the Cakchiquels must have *subtracted* 3 days from the 260 in order to keep their reckoning as we know they did. (*Ethnologie der Indianerstämme von Guatemala*, p. 66. Leiden, 1889.) His comparison of the methods of reckoning time among the Nahuas, Mayas and the nations of Guatemala is highly suggestive.

§ 4. THE 5-DAY PERIODS AND "YEAR-BEARERS."

The sequence of the days is found to be the same in all the Calendars which have been preserved, from whatever stock they have been derived. In all, also, the "month" of 20 days was divided into a series of 4 shorter periods of 5 days each. But here the similarity ends, for these 5-day periods did not uniformly begin on the day which we know was the first of the 20, nor was there any agreement between the various Calendars as to when they should begin. As the counts of the years and cycles were named after and adjusted by these "Dominical days," or, as the Mayas called them, "Year-bearers," this led to a certain confusion.

The differences will be seen in the following table, in which the numbers are those of the 20-day period on which the shorter periods of 5 days began in the several Calendars.

MAYA.	TZENTAL.	QUICHÉ-CAKCHIQUEL.	ZAPOTEC.	NAHUATL
4	3	2	1	3
9	8	7	6	8
14	13	12	11	13
19	18	17	16	18

It will be seen that the only two which agree are the Tzental and the Nahuatl; and the only one which began the 5-day and the 20-day periods on the same day was the Zapotec.

Nevertheless, the fact that the Calendar did begin on the first day of the 20-day period was distinctly recognized by these peoples. It is mentioned concerning the Mayas by Bishop Landa,* and by various writers of the Mexicans. Why and when the change was made remains extremely obscure and has received a variety of explanations at the hands of students.

Orozeo y Berra questioned the accuracy of Landa's statement, that the day *Imix* began the count in Maya, and suggested that what his informant meant was, that the day and number of *Imix* were duplicated every four years as a bissextile day, and in that sense began the reckoning.†

Dr. Seler explains the Nahuatl and Maya Dominical days thus: "The day *Acatl*, like *Kan*, belongs to the four chief signs with which the sequence of the years is indicated, and both refer

* Landa, *Relacion de las Cosas de Yucatan*, p. 246.

† *Historia Antigua de Mexico*, Tom. ii, p. 128.

especially to those years which are assigned to the East, the place of beginning."* This does not explain why these days rather than others were chosen as the "Year-bearers," or as the Dominical days. Nor is it accurate to say that the Calendars, when arranged, as was the custom, with reference to the cardinal points, began at the east. Motilinia tells us those of the Nahuas, at least those which he had seen, began with *Tochlli*, which was placed to the south; † and Ordonez y Aguiar, in the scheme of the Tzentel Calendar, which he copied from a native original, begins with *Lambat*, which he also places to the south; ‡ both of these being the eighth day of these calendars.

According to Dr. Förstemann, who has prosecuted such valuable researches into the Maya Codices, the Maya years began with *Imix* until towards the close of the fifteenth or the beginning of the sixteenth century, when the lack of an intercalary day led to a disorder in the reckoning. They then intercalated 17 days, and recommenced the regular account with *Kan*. He is of opinion that the Codex Troano shows the older form of reckoning, the Codex Dresdensis the newer.§

In some correspondence I have had with Prof. Cyrus Thomas, who has given long and fruitful attention to the study of the Maya Codices, he states his entire agreement with Dr. Förstemann that the Dresden Codex "follows the usual method of counting by the four-year series as the *Kan*, *Muluc*, *Ix* and *Cauac* years." As to the statement of Bishop Landa, Dr. Thomas writes me: "As we find several of the time series in the Codices commencing with this day (*Imix*), it is probable that the Indians in explaining to Landa hit on one of these, thus causing him to believe this to be a rule in counting years."

M. de Charencey believes that the Aztecs chose the third day of the series, the Mayas the fourth day, etc., with which to begin the count, because these numbers were specially sacred in these various nations from mythical associations or historic incidents. ||

* *Zeitschrift für Ethnologie*, 1888, p. 42.

† *Historia de las Indias de la Nueva España*, Trat. i.

‡ *Historia del Cielo y de la Tierra*, MS. This singular work is now in a private library in the United States.

§ See his article, "Zur Maya Chronologie," in the *Zeitschrift für Ethnologie*, 1891, pp. 111, 899.

|| Charencey, *Des Nombres Symboliques chez les Toltèques Occidentaux*, p. 19 (1893).

None of the above solutions can be deemed satisfactory. The fact remains, that among all these peoples the first day of the 20-day series was well known and recognized as such: and yet, except among the Zapotecs, it was not used as a Dominical day or a year-bearer. The Nahuas were well aware of this curious discrepancy, and had their own explanation of it, which, of course, is either purely mythical, or so esoteric that its interpretation escapes us. They said that the 5-day periods and the years did originally begin with day 1 and number 1 (*ce Cipactli*), and that this continued from the time of the invention of the Calendar down to the close of the fourth age of the world, a period of 2028 years; but as the fifth or present age began on the 8th day of the series and number 1 (*ce Tochtli*), this was then chosen in place of the former.* This 8th day was therefore placed on the south of the "wheel," and as the count was from right to left, it necessarily brought the 13th day, *Acatl*, to the east, and therefore the true series of Dominical days in the Aztec Calendar would run thus: 8 : 13 : 18 : 3.

Making this correction in this and the other Calendars, we obtain the following as the true sequence of the year-bearers in them, the numbers showing the position of the days in the 20-day series.

MAYA.	TZENTAL.	QUICHÉ-CAK.	ZAPOTEC.	NAHUATL.
4. Kan.	8. Lambat.	17. Noh.	1. Chilla.	8. Tochtli.
9. Muluc.	13. Ben.	2. Ig.	6. Lana.	13. Acatl.
14. Ix.	18. Chinax.	7. Queh.	11. Goloo.	18. Tecpatl.
19. Cauac.	3. Votan.	12. E.	16. Guilloo.	3. Calli.

Here again the Tzental is in accord with the Nahuatl, which diminishes the probability of it being a mere coincidence.

§ 5. THE 7-DAY PERIOD.

The Tzental appears to have developed the number 7 as an arithmetical element in their astronomical system. They had in their Calendars 7 days painted with black figures, the first be-

* See the discussion of the Nahuatl myths on the subject, by Paso y Troncoso, in the *Anales del Museo Nacional de Mexico*, Tom. ii, p. 354 *et seq.*, and Orozco y Berra, *Historia Antigua de Mexico*, Tom. i, p. 17. According to Ixtlilxochitl, the Tezeucans did not begin with *Tochtli*, but with *Tecpatl*, the latter being the date of the destruction of Tollan. This would give still another series: 18 : 3 : 8 : 13.

ginning with a Friday.* It is not possible from the jejune account we have of this feature to say whether it was based on the European week, or was the result of the subtraction of the 13 days of the native week from the 20 days of the month.

I am inclined to the latter view; for the Tzentsals were not the only nation employing this Calendar who had a 7-day period, although Orozco y Berra, in discussing the subject, asserts that they were.† We have, however, the testimony of Father Thomas Coto to the fact that the Cakchiquels of Guatemala had a period of similar length in their time count, though unfortunately he took so little interest in the subject that he mentions nothing beyond the bare fact.‡ And Father Varea, writing of the same nation, says that they observed a period of 7 days annually in Lent, during which they believed all animals, etc., retired into seclusion. To this period they gave the name *K'apî k'ih*, closed days or days apart, the same term which they applied to the intercalary days. §

The close relation of the 7 period to the 13 period is shown in the traditional history of the Cakchiquels. From the earliest times they were divided into 13 divisions, *K'hob*, and 7 tribes, *Amag'*. These were undoubtedly drawn from the numbers of the Calendar. ||

The attention of the native arithmeticians was naturally attracted to the number 7, as in order to know the number of the day in the 13-day list on which a given month would commence, they were obliged to add 7 to the number of the first day of the preceding month. This was the foundation of a series of tables preserved in several of the Maya "Books of Chilán Balam," bearing the title *Buk Xoc*, or General Computation, specimens of which have been given by Pió Perez. ¶

* "En muchos pueblos de las provincias de este obispado tienen pintados en sus repertorios o calendarios siete negritos para hacer divinaciones y pronosticos correspondientes á los siete dias de la semana, comenzandola por el Viernes á contar." Nuñez de la Vega, *Constituciones Diocesanas del Obispado de Chiappa*, Lib. i, p. 9.

† Orozco y Berra, *Historia Antigua de Mexico*, Tom. ii, p. 160.

‡ "Algunos meses duran veinte dias, y otros siete; que ni los acabaremos de entender, ni ellos se entienden, aunque tienen sus maestros en esta facultad." Thomas Coto, *Vocabulario de la Lengua Cakchiquel*, MS., 1651.

§ "K'apî kib: Siete dias que suelen caer en la quaresma, en los quales dicen los indios que se recogen todos los animales, montes, etc." Varea, *Vocabulario Cakchiquel*, MS.

|| *Annals of the Cakchiquels*, *passim*.

¶ In his Essay on the Maya Calendar, printed in the *Registro Yucateco* and in Brasseur's edition of Diego de Landa's *Relacion*.

Dr. Forstemann brings evidence to show that the Mayas at one time arranged the days of the solar year in 4 groups of 7 weeks each, each week being the native one of 13 days ($4 \times 13 \times 7 = 364$), and that each of these groups of 7 was assigned to a particular cardinal point.*

§ 6. THE VAGUE SOLAR YEAR.

Whatever might have been its origin or earlier uses, this period of 260 days was no longer at the time of the Conquest the received civil time measure, but was confined to divinatory, astrological and sacred purposes. It served to fix the festivals and fasts of religion, and to foretell the fate of individuals and nations.

No doubt these nations, like the northern hunting tribes, had in early times a rude and inaccurate method of noting the solar year, either by seasons, or lunations, or by the regular recurrence of natural phenomena. An effort was made to adjust to this the computation by vigesimal day periods, 18 of which gave 360 days. This still required 5 days every year and 1 more every 4 years to render the count accurate. The 5 days were noted, and annually allowed for as "useless," or uncounted days; but the 1 every 4 years, which we intercalate in our leap year, was probably not recognized in most tribes, and several careful authors think not anywhere. The assertions in reference to this by early authorities are obscure and unsatisfactory.

In spite of the fact that these 20-day periods in no wise corresponded to the lunar months nor were derived from them, they seem to have been very generally called by terms connected with the word for moon, which indicates that at some time they superseded a more ancient system of reckoning the solar year by a series of lunations.

This will be seen from the following examples:

The Cakchiquels, according to Varea, had two expressions for "month," the one, *iq*, evidently allied to *iq*, moon; the other, *atit*, the literal meaning of which is "old woman" (*muger*

* *Globus*, No. 2, 1892. The Nahuatl legend of the "Seven Caves, Chicomoztoc," whence issued their ancestors, and the repeated use of the number seven in the *Popol Vuh*, are other indications of the general sacredness of this number among the tribes under discussion. I have already quoted Mr. Cushing in reference to its meaning in the mythical rites of the Zuni's.

vieja). The Mayas spoke of the 20-day period as *u*, the moon or lunar month. The Tzentsals employed the corresponding term *i*, moon or month, and for year the word *avil* from the same root as the Maya *haab*.

There was no uniformity in the date of beginning the solar year. The Mayas were said to have begun it on July 16, the Cakchiquels on January 31, and as for the Quichés, three authorities before me, Ximenes, Gavarrete and a native Calendar, assign respectively February 27, December 24 and February 7. The same uncertainty prevailed everywhere.

§ 7. METHODS OF DIVINATION BY THE CALENDAR.

A study of the methods of divination by the Calendar as employed by these nations would be by no means profitless. To them, this use of it was far more important than as a time count. Man's fears and hopes, all the emotions which prompt his actions, look to the future rather than to the past; and for that reason prophets, when accredited, have ever enjoyed greater popular consideration than historians. We may be reasonably sure that the key to the few ancient Calendars which have been preserved to us, and also to the strange inscriptions on the ruined buildings of Central America, is to be found in astrology rather than in chronology.

The only early writer who enters into this with any degree of fullness is Father Sahagun, who devotes the fourth book of his "History of New Spain" to the judicial astrology of the ancient Mexicans.* Writing a hundred and fifty years later, Bishop Nuñez de la Vega, of the Diocese of Chiápas, states explicitly that the general principles then in use for soothsaying from the Calendar in that district were the same as those practiced in Mexico from the remotest known period; † and that they have

* The information on this subject supplied by Father Duran in his *Historia de las Indias de Nueva España*, Tom. ii, App. Cap. ii, is, according to his own statements, of doubtful correctness.

† "En cada successo escogian un Dios; y llegó cada uno a tener su *nagual*, y aun muchos, uno solo de astros, elementos, aves, pezes, y brutos animales, y algunos tan viles, y asquerosos, como hormigas, ratones, lechuzas y murciélagos. Este error fué passando y arraigandose tanto en los subsecuentes *Nagualistas*, que hasta oí en dia se ha practicado por Reportorios y Kalendarios del primitivo gentilismo, que en la substancia y modo de pronosticar por el numero de 20 y de 13, concuerdan los mas modernos con los mas antiguos, que se practicavan en Mexico; y solo en los nombres significado por los 20 caracteres en cada provincia son diversos, ó por ser diferente los idiomas, ó por no ser unos mismos los que poblaron." Nuñez de la Vega, *Constituciones Diocesanas*, Lib. ii, p. 134 (Roma, 1702).

not materially differed down to the present day, is proved by a native Quiché Calendar of 1854, which I have in my possession.

The decisions of the native astrologers as to which days are auspicious or the reverse did not seem to depend on any theories transmitted from nation to nation; although in the Calendars of a given nation there was a prevailing consensus of opinion among them. Thus, Sahagun remarks of the Mexican repertoires, "In general, in all the signs, the tenth and thirteenth days are good," while "the eighth and ninth days are usually bad."* It is consistent with this that we find the 9th days of all the signs chosen by malicious witches and sorcerers as those on which they would be most active in their evil designs.† The same number, 9, appears to have had some special meaning for the Quiché diviners, as in each of their months they had 9 good and 9 bad days, the remaining 2 being indifferent.‡ The Aztecs had 6 good days, 7 indifferent and 7 bad. §

The painted paper or skin on which the Calendar was represented by its symbols was taken as a ground on which lots were cast, and as they fell on one or other of the signs, they betokened a fortunate or unfavorable outcome of an undertaking.||

But it was especially to foretell the fate of a new-born child and to select his guardian spirit or *naqual*, that the Calendar was chiefly called in by the priesthood.¶ One name of a child was that of the day of its birth, both the number and the day name being expressed. This gives us those curious personal appellations often recurring in the early Spanish historians, such as Seven Winds, Five Serpents, and the like. Wherever they occur, we may be sure the nation made use of this Calendar.

§ 8. CALENDAR FESTIVALS OF THE MODERN QUICHÉS.

The natives of Guatemala of aboriginal blood continue to reckon by this ancient Calendar, and regulate by it certain recurrent festivals and rites which have little to do with the Christi-

* Sahagun, *Historia de Nueva España*, Lib. iv, Cap. ii, 16.

† Orozco y Berra, *Historia Antigua de México*, Tom. ii, p. 21.

‡ See Scherzer, *Die Indianer Santa Catalina Islavacm*, p. 15.

§ Diego Duran, *Historia de las Indias*, Tom. ii, p. 239, who names them.

|| Duran, *ubi supra*, p. 239.

¶ Father Juan de Cordova, who is our only authority for the Zapotec Calendar, explains at length its employment in divination, *Arte de la Lengua Zapoteca*, p. 201, *seq.* I do not extend my remarks on this subject, as I shall examine it fully in an article on "Nagualism," as it prevailed before and after the Conquest among these peoples.

anity to which they are ostensibly adherents. A writer of that country has furnished a description of these, and as the publication in which his article appeared is extremely rare,* and the facts pertinent, I shall quote some of them.

When a day name coincides with the number 8, the day is considered sacred and a rite is celebrated either of the first, second or third order of solemnity, according to its object, for instance :

The day 8 *Camcy* is that on which the souls of the departed are prayed for, and the sorcerers implored to keep evil-minded souls from injuring the living.

The day 8 *Kamel* was that on which in ancient times they sacrificed to the divinities of the field and of agriculture. At present, Saint Anthony occupies the place of the dethroned old gods, and to him they offer the first fruits and dance to the sound of the marimba.

On the day 8 *Batz*, which by their count falls in the last month of their year, † there is a sort of general summary of all the festivals of the year, when there is much dancing, much copal burned as incense, much discharge of rockets, the whole closing with a general intoxication of the participants on aguardiente.

The day 8 *Ee* is that devoted to the adjuration of a particular monkey, who is supposed to be seated on one of the hill-tops, and is therefore called "The God of the Hill" (Dios del Cerro). The native priests require numerous offerings from the faithful to placate him, which naturally find their way into their own stores.

The day 8 *Ah-mak*, like *Camcy*, is set apart to commemorate the dead. The native priests go forth in the evening and call upon them with loud voices, while the mourners tell the spirits thus summoned whatever family news or other incidents they think will interest them.

On the day 8 *Noh* is celebrated a festival dedicated to the house and the family. They call upon the names of their deceased ancestors and place upon the altar which is invariably set up a cup of water in which a piece of money is dropped, which piece will be handed the cura of the parish the next day

* H. Spina in *Boletín de la Sociedad Económica de Guatemala*, Dec., 1870.

† The Calendar to which this refers evidently, like that of the Cakchiquels, drops 3 of the 260 days; otherwise, 8 *Batz* would not always fall in the last month.

to pay for masses for the dead.* A curious feature of the invocations on this day is one to their navel strings, which, at birth, are buried within or close to the house. This recalls an ancient Mexican superstition. †

§ 9. WHERE WAS THE CALENDAR INVENTED, AND BY WHAT NATION ?

The comparison I institute throughout the different nations which adopted this Calendar of the names of the 20 days which make up the month, and those of the 18 months which make up the solar year, proves beyond doubt that the former are translations from some one original source, while the latter are almost entirely different in the different nations, and represent, therefore, later developments of the astrological Calendar, and various adaptations of it to the solar years of the several nations.

This fact leads the way to an important historical inquiry : To which one of the many linguistic stocks employing this Calendar must we assign the original form and meaning of the names of the days ? Whichever it is, to it we must also assign the first invention of this strange and intricate system which has played so important a part in the development of Mexican and Central American art, thought and religion.

Most of the older authors who credulously accepted the fables of the natives, and those of later date who follow in their footsteps, join in attributing the Calendar to the " Toltecs," who are imagined to have been a mighty people, of high culture, whose " empire " extended far and wide in southern Mexico and Central America. In another publication I have given abundant reasons to disprove this ancient story, and to reduce the Toltecs to the inhabitants of the small town of Tula, north of the city of Mexico. ‡

* Another name for this day is *gua raballú*, which I suppose to refer to this ceremony, and to be a compound of *gua*, fountain, spring ; *r*, his or its ; *ballú*, to fill ; *há*, house ; " the water that supplies the house," or something to that effect.

† At birth, the Nahuas buried the navel string (and placenta) with important ceremonies, as they believed its disposition influenced the after-life of the child. If it was a boy, an arrow and a shield were interred with it, that he might be brave ; if a girl, a *metate* and corn-roller were substituted, that she might make a diligent house-wife. See the Codex Mendoza in Kingsborough's *Mexico*, Vol. v. p. 91, and Sahagun, *Historia*, Lib. v, Appendix.

‡ See the article entitled " The Toltecs and their Fabulous Empire," in my *Essays of an Americanist* (Philadelphia, 1890).

Quite different is the opinion of more recent and able archaeologists.

In a work published in 1880 the historian of Mexico, Manuel Orozco y Berra, stated that, "without any doubt," the Calendar of the Zapotecs of Oaxaca was the original on which were based and from which were developed all the other Calendars of Mexico and Central America which had as their fundamental relations the periods of 13 and 20 days. He founded this conclusion, not on linguistic grounds, but on the more ancient and primitive character of the Calendar as preserved by the Zapotecs.*

In 1890, consequently ten years later, Dr. E. Seler expressed a similar belief that the Zapotecs were the probable inventors of the Calendar, his reasons being chiefly linguistic and archaeological.†

I frankly acknowledge that after carefully weighing all the evidence brought forward by these writers, and much more from my own researches, I have been unable to reach any definite decision on this question; though from various minor indications I think the probability is in favor of the opinion that it was the invention of that ancient branch of the Mayan stock who inhabited the present States of Chiapas and Tabasco, and left still visible proofs of their remarkable culture in the ruins of Ocozingo and Palenque.

In the relics from these ancient cities we find a development of art unequalled elsewhere on the American continent; and to this region the admirable analysis of Mayan antiquities by Dr. Schellhas inevitably points, ‡ as the scene of the definite beginnings of that stock's remarkable cultural evolution.

I have discovered no conclusive or even weighty evidence that we should look to the Zapotecs as the discoverers of the Calendar system; but I am far from denying the possibility that it may hereafter be adduced. It must be borne in mind, however, that we lack the material for studying the Calendar as

* Orozco y Berra, *Historia Antigua de Mexico*, Tomo II, cap. 1 (Mexico, 1880). M. Eugene Boban, in his *Catalogue de la Collection Goupil* (Paris, 1892), quotes and directs attention to Orozco's opinion.

† In the *Zeitschrift für Ethnologie* (Berlin, 1891), and in the *Compte Rendu* of the Seventh Congress of Americanists, p. 735 (Berlin, 1890). I have not observed that he refers to the priority of Orozco y Berra in defending this opinion.

‡ See his article, "Vergleichende Studien auf dem Felde der Maya-Alterthümer," in the *Internationales Archiv für Ethnographie*, Bd. III, 1890.

it was employed by the Mixtecs, a tribe of antique and developed culture, who had employed it for an indefinite period;* and are equally ignorant of its form and names among the Totonacos, who put forth the claim that they themselves had invented it, and had constructed the celebrated pyramids of the sun and moon on the plain of Teotihuacan as a permanent memorial of it.†

The period of 20 days is characteristic of this Calendar; and wherever in America we find the solar year divided into periods of this duration, we may be sure that the local Calendar is based on this ancient divinatory scheme. So far as I know, this does not occur outside of Mexico and Central America. The Peruvians divided their year into lunar months, and the Muyscas or Chibchas of Colombia, although, like the Cakchiquels of Guatemala, they had a year cycle of 20 years, measured each year by 12 months of 30 days each. In the Old World no similar combination of 20 and 13 in a time-count has come to my knowledge.

§ 10. THE LINGUISTIC ANALYSIS.

All who have made a study of this Calendar have appreciated the importance of a close etymological analysis of the names of the days and months. It was, as regards the Nahuatl, attempted by Boturini in the last century and more successfully by those versed in that language at the present day—but still leaving much to be desired.

In the Maya, Don J. Pio Perez paid considerable attention to these etymologies, and so also have Dr. P. Schellhas and Dr. Ed. Seler in Germany.‡ They have left, however, many gaps to fill, principally from their defective resources in a lexicographic appa-

* There are said to be one or two Calendars extant, as yet unpublished, of Mixtec origin. That this nation had a "month" of 20 days bearing the same names as those of their neighbors is evident from the statements in Herrera, *Hist. de las Indias*, Dec. iii, Lib. iii, cap. xiv, and Garcia, *Origen de los Indios*, Lib. v, cap. iv. These give the day names, Wind, Snake, Deer, Monkey, Tiger, Rose, etc.

† Torquemada, *Monarquía Indiana*, Lib. iii, cap. 18. According to the same authority, the first king of the Totonacos bore the name Ome Acatl, 2 Reed, which, if true, proves their knowledge of the Calendar at that time.

‡ Pio Perez's translations may be found in various publications, especially in Brasseur's edition of Landá's *Relacion de las Cosas de Yucatan*. Dr. Schellhas' analysis is in the *Zeitschrift für Ethnologie*, 1886, p. 19, *seq.*, and Dr. Seler's in the same periodical, 1888.

ratus for the Mayan stock. In this respect I am more fortunately situated, having access to a number of unpublished vocabularies in the Library of the American Philosophical Society and in my own collection. These include, for the Maya proper, the MS. dictionaries obtained from the convents of Motul and San Francisco, Yucatan, and named from them; for the Tzental the vocabulary of Father Domingo Lara,* and for the Quiché and Cakchiquel the MS. vocabularies of Fathers Varea, Coto, Guzman, Ximenes and Villacañas. For the Zapotec I have depended on an anonymous vocabulary in MS., the published works of the licentiate Belmar, the grammar of Father Juan de Cordova and the *Vocabulario Hispano-Zapoteco* recently issued in the city of Mexico. The Nahuatl is easily accessible through the dictionaries of Molina and Siméon.

With these at hand, I believe I am able to show beyond question :

1. That the day-names in all five of these languages and dialects are substantially identical in signification, and therefore must have had one and the same origin.

2. That in all the Mayan dialects the names belonged already at the time of the Conquest to an archaic form of speech, indicating that they were derived from some common ancient stock, not one from the other, and that, with one or two possible exceptions, they belong to the stock and are not borrowed words. On the other hand, none of the Nahuatl day-names are archaic, which appears to indicate that these received the Calendar at a later date.

3. That the theory of Boturini, subsequently espoused by the Abbé Brasseur and others, that the day-names refer to historic characters, is wholly without foundation.

4. That there is no evidence to connect them with astronomical bodies or processes, but that they seem purely divinatory and mythical.

*This is the writer called by the Abbé Brasseur in his *Bibliothèque Mexico-Guatiemalienne*, p. 10, "Ara," and the MSS. he describes are those now in my hands, two in number, copied in 1616 and 1620. Father Lara was provincial of Chiapas in 1596. See Beristain y Souza, *Biblioteca Hispano-Americana Selectiorum*, Tom. ii, p. 132.

§ 11. ANALYSIS OF THE DAY-NAMES.

List of the Usual Day-Names in the Maya, Tzental and Quiché-Cakchiquel Dialects, and in the Zapotec and Nahuatl Languages (the Dominical days in small capitals).

	MAYA.	TZENTAL.	QUÉ-CAK.	ZAPOTEC.	NAHUATL.
1.	Imix,	IMOX,	IMOX,	CHILLA,	Cipactli.
2.	Ik,	Igh,	IK,	Gui, Ni, Laa,	Ehecatl.
3.	Akbal,	VOTAN,	Akbal,	Guèla,	CALLI.
4.	KAX,	Ghanan,	Kat,	Guache,	Cuetzpallin.
5.	Chic chan,	Abagh,	Can,	Zii,	Coluatl.
6.	Cimi,	Tox,	Camey,	LANA,	Miquiztli.
7.	Manik,	Moxic,	QUEH,	China,	Mazatl.
8.	Lamat,	LAMBAT,	Canel,	Lapa,	TOCHTLI.
9.	MULUC,	Molo,	Toh,	Niza,	Atl.
10.	Oc,	Elab,	Tzi,	Tella,	Itzcuintli.
11.	Chuen,	Batz,	Batz,	GOLOO,	Ozomatli.
12.	Eb,	Euob,	EE,	Pija,	Malinalli.
13.	Ben,	BEEN,	Ah,	Quii,	ACATL.
14.	Hix,	Hix,	Balam,	Eche,	Ocelotl.
15.	Men,	Tziquin,	Tziquin,	Naa,	Quauhtli.
16.	Cib,	Chabin,	Ah mak,	Loo,	Cozcaquauhtli.
17.	Caban,	Chic,	NOH,	Xoo,	Ollin.
18.	Edznab,	CHINAX,	Tihax,	Goppa,	TECPATL.
19.	CAUAC,	Cahogh,	Cooc.	Appe,	Quiahiutli.
20.	Ahau,	Aghaua,	Ihunahpu,	Lao,	Nochitl.

The First Day.

1. Maya, *imix*; 2. Tzental, *imox* or *mox*; 3. Quiché-Cak., *imox* or *moxin*; 4. Zapotec, *chilla* or *chiylla*; 5. Nahuatl, *cipactli*.

It is evident that the three Maya dialects have the same word. Pio Perez regarded it as a transposition of *ixim*, maize, while Dr. Selser, following Dr. Schellhas, derives it from the root *im*, a teat or udder, both conveying an idea of fruitfulness.*

The occurrence of *mox* in Tzental, and *moxin* in Quiché-Cak. (the latter given by Ximenes in his *Vocabulario Cakchiquel*, MS.), shows, however, that the radical syllable is not *im*, but *m-x*. This leads me to identify it with the Maya *mex* or *mexx*, which is the name of a fish (the "pez arana," "un pescado que tiene

* The figure of a mamma, which represents this day in some of the drawings, is merely ikonomatic. This representation is noted by Dr. Schellhas, *Zeitschrift für Ethnologie*, 1886, p. 22.

muchos brazos"), probably so called from another meaning of *mex*, the beard, often used metaphorically, as *a mex kin*, the rays (beard) of the sun (*Diccionario de San Francisco*, MS.) The change of the vowel, in *mex* to *miz*, is not unusual in Maya. Pio Perez in his *Dictionary* gives, for instance, the old form *benel* to modern *binel*, *pem* to *pim*, etc.

On the other hand, we find in various dialects of the Maya the *i* retained in the word for "beard;" as Huasteca, *itzim*; Chaneabal, *itzimal*; Zotzil, *isim*, etc.; thus proving the identity of the two forms.

This identification brings this day name into direct relation to the Zapotec and Nahuatl names for the first of the Calendar. In the former *chiylla*, sometimes given as *pi-chilla*, is apparently from *bi-chilla-beoo*, water-lizard (lagarto de agua); and the Nahuatl, *cipactli* certainly means some fish or fish-like animal, a sword-fish, alligator, or the like, though exactly which is not certain, and probably the reference with them was altogether mythical.

The Second Day.

1. Maya, *ik*; 2. Tzental, *igh*; 3. Quiché-Cak., *ik'*; 4. Zapotec, *gui*, or *ni*, or *laa*, or *laala*, or *liua*; 5. Nahuatl, *hecatl*.

The three words of the Maya dialects all mean air, wind, breath, and, metaphorically, life, spirit, soul. So also does the Nahuatl *hecatl*, and indeed it may be questioned whether the Maya word is not a form of the radical *eh'e* of the Nahuatl.

The Zapotec offers greater difficulties. In that tongue we have *uii*, air, wind; *chiiv*, breath; which we may bring into relation with *gui*; and we find *guiiebo*, wind-and-water cloud (nube con viento y agua). Dr. Seler prefers to derive *gui* from *quii*, fire, flame, the notion of which is often associated with wind. *Ni* is apparently the radical of *nici*, to grow, increase, gain life; while *laa* or *laala* is a word with many meanings, as, warmth; heat; reason or intelligence. The sense common to all these expressions seems to be that of life, vitality.

The Third Day.

1. Maya, *akbal*; 2. Tzental, *rotan*; 3. Quiché-Cak., *akbal*; 4. Zapotec, *guèla*; 5. Nahuatl, *calli*.

The Maya *akbal* is a shortened form of *akabhal*, to grow dark, to become night. The Cakchiquel *akbal* signifies dark and, by

transfer, confused. The Zapotec *guèla* also means night, and, by transfer, old, harvest time, etc. These three, therefore, apply to the day a name of the same meaning.

The Nahnatl *calli* means "house," the Tzentatl *votan*, "heart." It is not difficult to connect these with the idea of darkness night or old age, on the ground that the house is that which is within, is dark, shuts out the light, etc. Possibly the derivation was symbolic. Votan, as a hero-god, was much venerated by the Tzents, says Bishop Nuñez de la Vega; he was called "The Heart of the Nation;" and at Tlazoaloyan, in Soconusco, he constructed, by breathing or blowing, a "dark house" (*una casa lóbrega*), in which he concealed the sacred objects of his cult. In this myth, therefore, which I have explained at some lengths in a previous work,* we find an unequivocal connection of the ideas of "darkness" and "house" united in the myth of Votan, indicating the oneness of the origin of all three in this relation. This is proved by the coincidence that Tepeyolltl, which has in Nahuatl the same meaning as Votan in Tzentatl, is the god who is patron of this day.†

The Fourth Day.

1. Maya, *kan* or *kanan*; 2. Tzentatl, *ghanan*; 3. Quiché-Cak., *k'at* (*k'ate, k'atic, gatu*); 4. Zapotec, *guache*, or *gueche*; 5. Nahuatl, *cuetzpallin*.

All sorts of meanings have been attributed to the Maya day name *kan*; as, hamac, rope, yellow, snake, and, by Dr. Selser, to abound in, abundance, to be in excess, etc. All agree that the Tzentatl *ghanan* is the same word under a slightly different form. In Cakchiquel, according to Guzman, *Compendio de Nombres*, MS., *k'an* is the name applied to the female of the iguana, or tree-lizard, and this I believe to be the original sense of the Maya and Tzentatl terms, corresponding closely to the Nahuatl *cuetzpallin*, which meant some species of lizard. The Za-

* *American Hero Myths*, p. 217: The word *votan* is the general term in Tzentatl for "heart" in both its physical and figurative senses, such as feeling, sentiment, courage, affection, life, etc. Dr. Selser finds in the prefix *o* an indication of the Maya *ol*, Nahuatl *yol*, heart; but it is needless to explain this prefix from foreign tongues. In Tzentatl, *yol* means that which is held or owned in common, that which belongs to the community and is common property (*comun cosa, yol; comunidad, yol, olol, olil*, Lara, *Vocabulario*).

† For a full discussion of this point, see Dr. Selser, in the *Compte-Rendu* of the Congress of Americanists, vii Session, pp. 561-569. He believes the Nahuatl Tepeyolltl was a deity borrowed from the southern nations (Zapotec or Maya stocks).

potec *guache*, translated by Seler as frog or toad, is more than likely to be a variant of *gorache*, or *gorache*, iguana (see *Vocabulario Castellano-Zapoteco*, s. v. Lagarto).

This leaves the Cakchiquel *kat* or *qat* to be explained. Ximenes says it is *cat*, a net for carrying maize, but means lizard. Scherzer states that the present translation of the word among the Quichés is *kat*, fire. The connection probably was symbolic, the iguana being the type of fullness or food, which the net full of maize ears also typified. Precisely parallel to this is the name for this day in the Nahuatl of Meztitlan, *xilotl*, an ear of corn.

The Fifth Day.

1. Maya, *chic chan*; 2. Tzental, *abagh*; 3. Quiché-Cak., *can*; 4. Zapotec, *cí*, or *ziie*, or *guii*; 5. Nahuatl, *cohuatl*.

Pio Perez offers no explanation of the Maya *chic chan*, while Dr. Seler says that "undoubtedly" it means "a sign marked or taken." To give this sense it would have to be read *chech*, a sign or mark; *ch'uan*, something taken or carried away. There is much less difficulty in construing it as *chich*, strong or great, and *chan*, the generic Tzental term for serpent. The Cak. *can* also means serpent, especially the viper, Guzman giving *raxa can*, the green viper; *k'ana qanti*, the yellow viper, and other compounds. The Nahuatl *cohuatl* is the generic term for serpent in that tongue.*

The Tzental *abagh* is a different word. It means in that dialect and in Cakchiquel, luck, fate, fortune (*dieha ó ventura*, Ximenes, *Vocabulario*, MS.). This is identical with the Zapotec *ci* or *zii*, and *gui* (*xi-gui*, hado ó ventura; *bi-zi*, agorar; *gui*, ganancia; *rnni-bizii*, agorar ó ereer en el canto de las aves ó *culebra*. *Vocab. Castellano-Zapoteco*). As in this last example the serpent is especially noted as the animal whence portents were derived, the close connection of the day-names is obvious.

The Sixth Day.

1. Maya, *cimi*; 2. Tzental, *tox*; 3. Quiché-Cak., *camey*; 4. Zapotec, *lana*; 5. Nahuatl, *miquiztli* or *tzoutcomatl*.

The Maya *cimi* is from *cimil*, death, to die; the Quiché-Cak. *camey* means death, or, a corpse; the Nahuatl *miquiztli* = death;

* Dr. Schellhas points out that the Maya sign for this day is derived from the head of a snake (*Zeitschrift für Ethnologie*, 1886, p. 20).

and *tzontecomatl* = a human head cut off, or, a skull. The Tzentäl *tox* seems to refer to the last-mentioned idea; it means what is separated, sundered, cut off; hence *tox-oghbil*, the axe or hatchet;* *q-tox*, to split, to divide, cut off (Lara, *Vocabulario*, MS.). In this it agrees precisely with the Zapotec *lana*, which the Zapotec Vocabulary renders as a separated part or thing, like a single syllable, word or letter (*silaba ó parte*).†

In this and the previous day-name it is interesting to find the Tzentäl and Zapotec coinciding, while differing entirely from the other tongues. These analogies have escaped the attention of other students of the subject; and their importance in throwing light on ancient ethnic relations is manifest.

Though the immediate meanings of the various names of the day differ widely, they are clearly connected by the same underlying train of ideas, and indicate unity of origin.

The Seventh Day.

1. Maya, *manik*; 2. Tzentäl, *moxic*; 3. Quiché Cak., *queh*; 4. Zapotec, *chína*; 5. Nahuatl, *mazatl*.

The Nahuatl, the Zapotec and the Quiché-Cak. words are all the ordinary terms for "deer" in those languages (Zap. *bi-chína*).

The Maya *manik*, I am persuaded, is derived, as Pio Perez suggested, from the irregular verb *mal* (*mani*, *manac*, as given in the *Dicc. Motul*), to pass by rapidly, to have a quick, restless motion, and *ik*, wind, the deer being referred to metaphorically by this characteristic trait.‡ Dr. Seler's suggestion, that it is a compound of *may-nik*, cloven hoof, seems more remote.

The Tzentäl *moxic* offers greater difficulty. It is not easy to accept Seler's suggestion that it is from the Maya *maxan*, swift, for this is a secondary word in that dialect, compounded of the negative *ma*, and means "not slow;" it is not likely that it would be used as a stem word in another dialect. According to Guzman, *Compendio de Nom. en Lengua Cakchiquel*, MS. 1704,

* "*Tox*, hacha para cortar leña." different in form from the "*hacha para labrar tierra*," called *bat-zil*, to be referred to later.

† Other meanings of *lana* are: the middle; dark; flesh or meat; words; secretly; etc.

‡ The hieroglyphs of this day sign, both in the Maya and Nahuatl, sometimes contain the elements of the sign of the four winds, as has been pointed out by Dr. Schellhas and Dr. Seler.

the Cakchiquels used as the generic word for deer the term *matzat*, evidently from the Nahuatl *mazatl*; and perhaps the Tzental *moríc* is merely a further corruption of the same.

The Eighth Day.

1. Maya, *lamat*; 2. Tzental, *lambat*; 3. Quiché-Cak., *canel* or *kanel*; 4. Zapotec, *lapa* or *laba*; 5. Nahuatl, *tochtli*.

The names of this day differ widely in meaning. The Nahuatl *tochtli* is the ordinary word for "rabbit," and Dr. Seler attempts to trace an analogy by translating the Zap. *lapa* as "the divided (nose)," referring to the rabbit, and then that the Tzental *lambat* and Maya *lamat* are corruptions of this word.

This procedure is unnecessary. The Maya *lamat* is evidently a shortened form of the Tzental *lambat*, which is composed of *lam*, to sink into something soft ("hundirse en cosa blanda," like light loam), and *bat*, the grain, the seed, and the name refers to the planting of the crops.

The Quiché-Cak. *kanel* is the name of the Guardian of the Sown Seed,* probably from *kan*, yellow, referring to the yellow grains of maize. The Zapotec *lāpa* or *laba* means, a drop, and a crown or garland; here probably the latter, in reference to the product of the fields. The rabbit, in Nahuatl, is the symbol of ease and intoxication.

There seems, therefore, a close analogy between these terms.

The Ninth Day.

1. Maya, *muluc*; 2. Tzental, *mulu* or *molo*; 3. Quiché-Cak., *toh*; 4. Zapotec, *nizu* or *queza*; 5. Nahuatl, *atl* or (Pipil) *quihuitl*.

The Nahuatl names mean respectively "water" and "rain;" the Zapotec are also the words for "water." *Toh* was the Quiché name of the god of the thunder-storm, from *tohil*, to sound loudly, to resound, and was thus associated with the rains. The Tzental and Maya *mulu* and *muluc* are from the radical *mul*, to heap up, to pile up; which evidently cannot refer to the "gathering together of waters," as Dr. Seler suggests,

* "Genius der Aussaat" of the natives of Ixtlavacan in Guatemala (Scherzer). On this day the ancient Cakchiquels sacrificed to the gods of fertility and abundance. *Boletín de la Sociedad Económica de Guatemala*, Dec. 15, 1870. In the *Popol Vuh*, the goddess of fertility is called *Xpunitl*. Another meaning of *bat* in Tzental is hoe (*hacha para labrar tierra*, Lara, *Vocabulario*).

but rather to the heaping up of the clouds in the sky on the approach of the rains.

Compare the Tzental *toh-cal*, clouds; Mame *muh*, Maya *muh-yal*, clouds (Stoll, *Ethnog. Guatemalas*, p. 59).

The Tenth Day.

1. Maya, *oc*; 2. Tzental, *elab*; 3. Quiché-Cak., *tzi*; 4. Zapotec, *tella*;
5. Nahuatl, *itzcuintli*.

The Nahuatl and the Quiché-Cak. are the ordinary terms for "dog." Such also, according to Bartolomé de Pisa, is the meaning of the Zapotec *tella*, though I do not find it in this sense in the Vocabularies.* Probably it refers to some particular species.

The Maya *oc* has a variety of meanings, as, a foot or footprint; a handful; an entrance (from the verb, *ocol*, *ocoltah*, *ocolte*, to go in); a theft or thief (from the verb, *ocol*, *oclah*, *ocle*, to steal). I am inclined to believe that the last-mentioned sense was intended, the dog being characterized as "the stealer," as this seems to be the signification of the Tzental *elab*. The two words given by Lara for "theft" (*ladronico*) are *elec* and *ochol*, in which we can scarcely fail to recognize the two names of the day in these two dialects. The dog steals in and carries off the meat whenever he gets a chance. The Mayas adopted the term from the stem *ochol*, because this was the word for theft in their dialect, in which the stem *elec*, common to the Tzental, Zotzil, Cakchiquel and Quiché, does not appear.†

The Eleventh Day.

1. Maya, *chuen*; 2. Tzental, *batz*; 3. Quiché-Cak., *batz*; 4. Zapotec, *loo*;
5. Nahuatl, *ozomatli*.

The Nahuatl is the term for "monkey;" *batz* in Quiché, Cakchiquel and Tzental also means monkey, specifically a dark-haired, bearded variety. In the Tzental, according to Lara's Vocabulary, another species is called *chiu*, and this unquestion-

* "En el pueblo de Coatlan tenian un Cazique que se llamaba *Ptella*, que significa *perro*," etc. Herrera, *Decadas de Indias*, Dec. iii, Lib. iii, cap. xiv. This chief was one of the Zapotec rulers who secretly continued the ancient rites after the introduction of Christianity. Dr. Seler attempts to obtain the meaning "dog" by supposing *tella* is derived from *tee-lao*, "mouth downward," referring to some myth of a dog falling from the sky. This seems strained.

† The common term for "wolf" in Tzental and Zotzil is *ocquil*.

ably is the origin of the Maya *chuen* (a word which has no signification in that dialect) and of the name *chouen* in the National Book, the *Popol Vuh*, of the Quichés.*

The Zapotec syllable *loo* is given as the name of the 11th, the 14th and the 20th days, but is probably an abbreviation of different words. Taken alone, it has various meanings, as, face; eyes; above; point; beginning, first, etc. Here it may be intended for *bil-loo*, monkey, as the form of the name generally given in Cordova's Calendar is *pel-loo*.

The Twelfth Day.

1. Maya, *eb*; 2. Tzental, *euob*; 3. Quiché-Cak., *e* or *ee*; 4. Zapotec, *p̄ja*; 5. Nahuatl, *malliulli* and *itlan*.

The Nahuatl and Zapotec names both signify the brush or broom of twisted twigs or stiff grass used for cleaning and dusting, and this grass itself.

In Maya, *eb* is the plural of *e*, which means points or ends, like those of pins, or thorns (*puntas como de alfiler, aguja, espina, y cosas asi, Dice. Motul*), and plainly was intended to designate the broom by reference to its numerous points. From the same idea, rows of teeth received the same name. The Tzental and the Quiché names, *e* and *euob*, the latter a plural, were from the same radical and had the same signification. All five, therefore, conveyed similar ideas, and it is noteworthy that the day-name *itlan*, used in Meztitlan, is from *tlantli*, tooth.†

The Thirteenth Day.

1. Maya, *ben*; 2. Tzental, *ben*; 3. Quiché-Cak., *ah*; 4. Zapotec, *quii*, or *i*, or *lau*; 5. Nahuatl, *acatl*.

The Nahuatl means reed or stalk, as do also the Zapotec *quii* and *lau*. The Quiché-Cak. *ah* denotes a green cornstalk or sugar cane (*la caña ó la caña dulce; ó mais tierno, Ximenes*). The Tzental and Maya *ben* has been more difficult to analyze. Pio Perez and Dr. Selser expressed themselves at a loss to offer

* The brothers Hun Batz and Hun Chouen were conquered and transformed into monkeys by the victors. *Popol Vuh*, p. 1B. The present pertinence of this myth is that it shows that the words *batz* and *chouen* were both understood to refer to species of monkeys by the Quichés.

† Though it may possibly be a shortened form of *itlan*, the name of a plant used in making such brooms. Comp. Sthagan, *Historia de Nueva España*, Lib. xi. cap. vii.

a satisfactory rendering of it. I find, however, that in Tzentäl the dried cornstalk (*caña de mais seco*) is called *cagh-ben*, and from this I doubt not this day-name in that dialect and the Maya was taken and syncopated. The verb *ben* or *been* in Tzentäl means "to walk, to go;" but in the above compound the *ben* is from the Maya stem *benel*, to be used up, to be dead (*faltar ó quedar algo por hacerse de lo que se hacia, morirse, Dicc. Motul*).

We thus obtain substantially the same meaning for all the names of the day.

The Fourteenth Day.

1. Maya, *ix* (*gix, hix*); 2. Tzentäl, *hix*; 3. Quiché Cak., *balam* or *hix*;
4. Zapotec, *eche*; 5. Nahuatl, *ocelotl*, or (Pipil) *teyollocuani*.

The Nahuatl name *ocelotl* means tiger, as does the Zapotec *eche* and the Quiché *balam*, referring of course to the American tiger or jaguar.* The Pipil *teyollocuani*, literally "soul-eater," means sorcerer, as does the Maya, Tzentäl and Cakchiquel word, *hix* or *ix*. The power of transforming themselves into a tiger was one of the peculiar faculties of the sorcerers; hence they were called by the Quichés, *balam*, which means both tiger and to transform one's self into one (*Balam*: tigre, ó hacerse tigre, Ximenes).

It is probable that *ix* is a variant of *ik'* or *igh*, wind, breath, life, as Lara gives: "*Vuch-igh*, ó *Vuch-ix*, hechicero que cura soplando," in which *vuch* is to blow, as the medicine man through a tube; and *igh* is air, wind, etc. In the medicine rites over most of the continent, and especially in Central America, blowing upon the part or in a certain direction was the leading ceremony.

The Fifteenth Day.

1. Maya, *men*; 2. Tzentäl, *tziquin*; 3. Quiché-Cak., *tziquin*; Zapotec, *naa* or *ñaa*; 5. Nahuatl, *quauhtli*.

The Nahuatl *quauhtli*, eagle, and the Tzentäl and Quiché *tziquin*, bird in general, are sufficiently alike to show a common origin.

The Zapotec *naa* is identified by Dr. Seler with *naa*, mother; but I believe it is from the widely extended root word, *na* or *ña*,

*The full form in Zapotec is *be-eche-guia*.

to know, to understand, to be able through knowledge. In this sense it exactly corresponds to the Maya *men*, which means to understand, to be able to do (*men*: entender algo, hacer algo, *Dicc. Motul*). Hence, in this latter tongue, *ah-men* means the man of knowledge, the wise one, the master of wisdom.* The bird, as the symbol of wisdom and knowledge, was familiar to the mystical lore of these peoples.

The Sixteenth Day.

1. Maya, *cib*; 2. Tzental, *chabin*; 3. Quiché-Cak., *ahmak*; 4. Zapotec, *guilloo*, or *loo*; 5. Nahuatl, *cozcaquauhtli*, or (Pipil) *tecolotl*, or (Meztitlan) *teotl ñonal*, or *temetlatl*.

The Nahuatl names of this day mean: *cozcaquauhtli* (from *quauhtli*, eagle; *cozcatl*, necklace), the ringed vulture, *Sarcorampus papa*, or "royal zopilote" of the ornithologists, a handsome bird with a ring of red feathers around its neck; *tecolotl*, the owl; *teotl ñonal*, the day god, or the sun god; *temetlatl*, the pestle or corn-crusher. The Zapotec, which Cordova gives also in the forms *pillaloo*, *peoloo*, etc., is likely to be for *ba-loo*, crow or raven. The Quiché *ahmak* means "the master of evil," which appears to be a reference to the owl, which was esteemed a bird of evil omen and bad fortune by these peoples †—a metaphorical rendering therefore of the Pipil *tecolotl*.

The Maya *cib* is assigned by Pío Perez the meaning "wax," or "copal gum," and is derived by Dr. Selser from *ciz*, something that smells or tastes good, as spice or incense. I believe it to be merely another form of *tzib*, to paint (*tzibal*, cosa pintada de muchos colores), and that it refers to the brilliant neck and head feathers of the ringed vulture.

The Tzental radical *chab* means honey, wax, a bee, a late meal, to fast, syrup, to end or cease, to remain, mourning, funeral rites. It is not easy to select from such an abundance. In the

* As the Zapotec *benni chi na*, "man of knowledge." Another meaning of Zap. *ñaa* is "hand."

† For examples see my *Essays of an Americanist*, pp. 114, 169. The Nahuatl *tlaca-tecolotl*, "man-owl," meant a necromancer, one who worked injury. See Sahagun, *Hist. de Nueva España*, Lib. iv, cap. xi. Dr. Selser translates *ah-mak* by "der die Augen auffrisst," but in this he has mistaken the word *mak*, evil, for *mah* (arrebatar, Villacañas, *Vocabulario*, MS.). But I observe that Dr. Stoll gives as the Chontal word for zopilote, *ajmaa* (*Zur Ethnographie Guatemalas*, p. 54). The adjective *mak*, bad, is a compound of *ma lek*, not good.

Cakchiquel, *chab* means arrow, and to shoot one; also to open the mouth; while *ch'ab* is mud, clay, mire. As red and black clays were the primitive pigments, this last may connect the Tzentlal day name with the Maya.

The Seventeenth Day.

1. Maya, *caban*; 2. Tzentlal, *chic*; 3. Quiché-Cak., *noh*; 4. Zapotec, *xoo*; 5. Nahuatl, *ollin*, or (Meztitlan) *nahui olli*, or (Pipil) *tecpila nahuatl*.

The Maya *caban* has been explained by Dr. Seler diversely as "what is below," or "brought below," and again as "above," "what is above," "heaven," etc. Pio Perez offered no explanation of it. I derive it from the Maya radical *cab*, might or strength (la fuerza, rigor, ó fortaleza de alguna cosa, *Dicc. Motul*). In this sense it corresponds precisely in meaning with the Tzentlal *chic* (= Maya, *chich*, cosa fuerte y dura), the Quiché-Cak. *noh*, strong, great, and the Zapotec *xoo*, which has the general signification of force, power or might (comp. Cordova, *Arte Zapoteca*, p. 114).

The Nahuatl *ollin* or *olin* means motion or movement, the result of force applied, as *in tlalli olini*, the earth moves, an earthquake. *Nahui olin*, "the four movements," is an expression which refers to the apparent movements of the sun.

The Eighteenth Day.

1. Maya, *edznab*; 2. Tzentlal, *chinax*; 3. Quiché-Cak., *tihax*; 4. Zapotec, *gopaa*; 5. Nahuatl, *tecpatl*.

The Nahuatl term means flint, especially the flint stone knife used in sacrificing to cut the victim. The Zapotec *gopaa*, which Dr. Seler derives from *rogopa*, cold, is more likely to be a variant of *guipa*, a sharp point or edge, whence the word for stone knife, *guezá-guipa*, from *guia*, stone.

The Tzentlal *chinax* is an old or sacred form for the usual *zú-nax*, knife (Lara); and the Cakchiquel *tihax*, the literal meaning of which is, according to Ximenes, "it bites, scraping" (muerte rasgando), would seem to be a figurative and highly correct expression for such an implement.

There remains the Maya *edznab*. Pio Perez offers no explanation of it, while Dr. Seler suggests that it may be from the

root *edz*, hard, solid. It appears rather to be a figurative expression for the sacrificial knife, from *nab*, something anointed or blood (*cosa ensangrentada*),* and *edz*, to adjust, to point, to sharpen (as in the phrase, *edzcable a tokyah*, punta la lanceta para sangrar, *Dicc. Molul*). Thus, the same signification underlies these various names.

The Nineteenth Day.

1. Maya, *cauac*; 2. Tzental, *cahogh*; 3. Quiché-Cak., *caok*, or *cook*; 4. Zapotec, *ape*, *appe*, or *aape*; 5. Nahuatl, *quiahuiltl*, or (Pipil) *ayoll*.

The three Maya dialects present obviously the same word. The Tzental has been by some writers erroneously spelled *cahogh*, and Dr. Seler, following this false orthography, obtains for it the extraordinary meaning, "the darkness descending and overspreading the Earth!" Nuñez de la Vega gives *cahogh*, and no other form. It is a pure Mayan word, meaning "lightning and thunder," the concomitants of the electrical storm. The Pokomchi and Pokomam have precisely this form, *cahok*, *cohoc*; Lara gives the Tzental *chauc* (relampago, trueno, tronido, *Vocabulario*, MS.), the Chontal *chanoc*; the Huasteca, *tzoc*, proving that it is an ancient radical of this family, as this is the remotest of the Mayan dialects.

The Zapotec *ape*, *api*, etc., which Dr. Seler translates "cloud covered," evidently means the same, as we see in the words *laari-api-niza*, *ri-api-laha*, translated "relampago, relampaguear," in the *Vocabulario Castellano-Zapoteco* (Mexico, 1893).

The Aztec *quiahuiltl* is the ordinary word for ruin; while the Pipil *ayoll* means turtle, which is quite in correspondence with "lightning" as the day-name, this being, as Dr. Schellhas has so well shown, the "lightning animal," *das Blitzhier*. †

*To confirm this rendering, I add that Sahagun specially states that the *terpall*, or flint, was represented in the Mexican Calendars "stained with blood for the half of its length," *Historia de la Nueva España*, Lib. iv, Appendix. It was the *iztapaltotec*, "pedernal ensangrentado" of the *Codex Telleriano-Remensis*, Lam. xxxii.

† Dr. Schellhas points out that in the Maya pictography the turtle is a sign of the lightning, or the thunder-storm. It is associated with the hieroglyphs of the months Kayab and Pop. See his article, "Die Göttergestalten der Maya Handschriften" in the *Zeitschrift für Ethnologie*, 1892, p. 120. It is not easy, at first sight, to understand why so proverbially slow an animal should become the symbol of the lightning. My explanation is that it is an example of the "ikonomatic" method. The Mayan term for lightning is *caoc*, or *cauc*; the word for turtle is *coe*; from the similarity of the sounds, the turtle was used in the picture writing to mean "lightning."

The Twentieth Day.

1. Maya, *ahau* ; 2. Tzental, *aghual* ; 3. Quiché-Cak., *hun ahpu* ; 4. Zapotec, *lao*, or *loo* ; 5. Nahuatl, *xochitl*, or (Meztlitlan) *ome xochitonal*.

The Maya word means ruler or chieftain, literally, "the master of the collar," *i. e.*, the insignia of office ; * the Tzental *aghual* is from the same root and signifies "sovereignty ;" the Quiché *hun ahpu*, the One Master of Power, conveys a similar idea. The Nahuatl *xochitl*, flower or rose, is explained in its real sense by the *xochitonal* of the dialect of Meztlitlan, "the flower of the day," *i. e.*, the sun. This has been fully shown for the Nahuatl by Dr. Seler, and there is no doubt but that the "ruler" referred to by the Maya dialects is specifically the sun, the day god.

The Zapotec *lao*, or *loo*, here has the meaning "eye," that is, in reference to the sun as "the eye of the day," precisely as in the Maya expression *Kin ich*, which I have elsewhere explained. †

All the names of the 20th day, therefore, convey the same esoteric signification.

A careful examination of this list of day-names shows that at least in eight instances (Days 1, 2, 7, 11, 13, 17, 18, 19) the names are merely translations of the same word ; and that substantially in all the remainder, the differences which exist arise from using a figurative instead of a literal rendering of the name.

There can be no question therefore but that the Calendar names had one and the same origin ; but in which of the three linguistic stocks represented the list offers no positive evidence. The Zapotec, which is the language geographically intermediate between the Maya dialects and the Nahuatl, agrees with the latter in five instances where it disagrees with the former ; and agrees with the Maya in three instances where it disagrees with the Nahuatl names. Three times the Zapotec agrees with the

*The derivation of *ahau* from a theoretical root *ahu*, as proposed by Dr. Seler, is unnecessary ; *ah-auh*, "the collar-bearer," because this was a symbol of authority (compare the stone collars from Porto Rico, etc.), remains the most plausible etymology.

† The full expression is *Kin-ich-ahau*, Lord of the Eye of the Day, which explains this day-name, Ahau. See my *American Hero Myths*, pp. 153, 158

Tzental, where both disagree with all the other dialects. But these instances do not justify any conclusion. The possibility remains that all five of the lists are derivatives from some older and now lost series of day-names, such as we know existed among the Mixtecas and among the Totonacos, tribes of ancient culture, who made use of this Calendar at a remote date.

In all five instances there is evidence that at the time of the Conquest there was considerable uncertainty among the natives themselves as to the derivation and literal meaning of many of these names. Either they belonged to a much older and forgotten stratum of the tongue, or to a priestly and esoteric form of speech, such as has been found among many native tribes on the continent. But this esoteric speech is nearly always largely archaic.

§ 12. ANALYSIS OF THE MONTH-NAMES.

While the names of the twenty days of each month are practically identical in all the five languages under consideration, the reverse is the case with the names of the eighteen months which made up the vague solar year. These differ widely in tribes very closely related, as the Quiché and Cakchiquels; and even in the same dialectic area, as among the Nahuas. The month-names of the last-mentioned have been carefully analyzed by various writers, notably Dr. Selser, and I have not found the names of the Zapotec months; so I shall confine myself to an examination of them in the Maya, Tzental, Cakchiquel and Quiché dialects, and in the language of the Chapanecs, in which the month-names, but not the day-names, have been preserved.

THE MAYA MONTHS.

The earliest authority for the names of the Maya months is the Bishop Diego de Landa in his well-known description of Yucatan, composed about the middle of the sixteenth century.* Another list, not differing materially, was published by the Yu-

* Landa, *Relacion de las Cosas de Yucatan*. An edition with a French translation by the Abbé Brasseur (de Bourbourg) was published at Paris in 1861. One more correct and complete, in Spanish only, appeared under the editorship of Juan de Dios de la Rada y Delgado at Madrid, in 1884. For a comparison of these, see my "Critical Remarks on the Editions of Diego de Landa's Writings," in the *Proceedings of the American Philosophical Society*, 1887.

catecan antiquary, Pio Perez, copied from the books of Chilán Balam in his possession.*

An examination of these names shows that they are materially different from those in use among the other tribes of this stock. They appear, in Yucatan, to have reference generally to the religious festivals and ceremonies recurring at certain seasons; while in the other branches of the stock, they usually indicate the seasons or the appropriate periods for agricultural operations.

Months of the Maya Calendar.

1. Pop.	10. Yax.
2. Uo.	11. Zac.
3. Zip.	12. Ceh.
4. Zodz.	13. Mac.
5. Tzec.	14. Kan kin.
6. Xul.	15. Moan.
7. Yax kin.	16. Pax.
8. Mol.	17. Kayab.
9. Chen.	18. Cum ku.

Derivation.

1. *Pop.*—Literally, a mat or rug. But in its metaphorical sense in most Maya dialects, the community or commonwealth. Thus *popol no*, the public buildings, people's house; *popol vuh*, the national book, etc. As the name of the first month of the year it probably refers to the great national festival which then took place as described by Landa, p. 276, sq.

2. *Uo.*—Usually translated "frog;" there is a large edible species so called, who croak in a melancholy way (dan *gritas muy tristes*, *Dicc. Motul*). It is also the word for the fruit of the pitahaya, *Cereus trigonus*; in Tzental, *uanac*. The frog was the symbol of water and the rains.

3. *Zip.*—Pio Perez says there is a tree called *zip*. I can find

* Don Juan Pio Perez gave a copy of his essay to Mr. John L. Stephens, who published it (imperfectly) in the Appendix to his *Travels in Yucatan*. Later it appeared in the *Registro Yucateco*; from which it was copied by the Abbé Brasseur into the volume containing his edition of Diego de Landa.

The "Books of Chilán Balam" are the sacred books of the modern Mayas. I have described them at length in an article in my *Essays of an Americanist* (Philadelphia, 1890).

none such in my authorities. The real significance of the name is revealed by that of the goddess of hunting, in whose honor the festivals of the month *Zip* were held. This was *Zuhuy Zip*, the virgin *Zip*, her name being properly *Dzip*, to skin, to dress slain animals (see Landa, p. 290).

4. *Zodz*.—Also given *Tzoz* and *Zolz*. Probably the correct orthography is *Dzoz*, which means to be seated, as in waiting; Landa stating that in this month there was no festival, but merely preparations for one which was to follow. Another meaning of *Dzoz* is the setting or brooding of birds. *Zodz* is the generic term for the bat; there are no words *Zolz* or *Tzoz*.

5. *Tzec* or *Zec*.—In this month the bee keepers held their annual fast and festival. The word *Tzec*, to admonish, to correct by chastisement, apparently refers to some religious penance which was then practiced. In Tzental, *Tzec* means scorpion.

6. *Xul*.—Means end, conclusion. At the end of this month, on its last day, at the close of the five days' feast of *chich kaban*, "the calling down of the Great Hand," the chief god of the Mayas, *Ku kul can*, was believed to descend from heaven and accept the offerings presented to him by the faithful (Landa, p. 302).

7. *Yax kin*.—A compound of *yax*, blue or green (the Mayas not distinguishing between these hues); and *kin*, sun, day or season. This month was largely passed in a religious exercise called *olob dzab kam yax*, "giving the hearts to the service of the blue." All instruments, weapons and utensils, and even the doors of the houses, were then stained with a blue dye (Landa, p. 303). These were therefore the "blue days." The form *Dze yax kin*, given by Pio Perez is explained by the *Dicc. Motul* as the height of summer, probably from the blueness of the sky at that season.

8. *Mol*.—From the verb *mol*, to come together *en masse*, referring to the general reunion, *fiesta general*, which Landa tells us was celebrated in this month, when even the little girls were

present, brought under the care of an old chaperon known as the *ix mol*, "conductress of the crowd."

9. *Chen* or *Cheen*, properly *Ch'een*.—Derived by Pio Perez from the word for well or spring, but properly from a homonymous root which means, to be quiet, to keep silence, referring, I take it, to the solemn action of renewing the gods or making new idols, which took place in this month; a work, says Landa, they undertook with great fear—*con mucho temor*.

10. *Yax*.—In this month occurred the cleaning and renovation of the temples and the installation of the new gods. Hence *yax* is here used in the sense green, fresh, new or first, with reference to this function.

11. *Zac*.—In this month an important rite was celebrated by the hunters in expiation of the blood shed in the chase. As in the native symbolism white signifies peace and propitiation, the month probably derived its name, *zac*, white, from this rite.

12. *Ceh*.—The common word for deer or any large food game. Landa does not assign any festival to this month, but the name probably has reference to that of the hunters just referred to.

13. *Mac*.—In this month the Mayas celebrated the rite of *tup kak*, "extinguishing the fire," for the purpose of securing abundant rains for the harvest. A fire was built in the court of the temple, the hearts of various animals thrown into it, and as soon as they were consumed the priests poured water upon the flames and extinguished them (Landa, p. 254). The root *mac* means to cover, or, a cover, the rite being a "couvre-feu," or covering up of the fire.

14. *Kan kin*.—Translated by Pio Perez "yellow sun," "because in this month, owing to the forest fires, the sun looks yellow through the smoke in the air."

15. *Moan*, or, *Muan*.—Rainy or cloudy. Pio Perez adduces the term *moan kin*, cloudy day, threatening to rain. The word is not in the old dictionaries, but it is doubtless from the same

root as *manaal*, which the *Dicc. Motul* explains as “aguaceros que vienen antes de que entran las aguas de golpe, con los cuales suelen florecer arboles, matas y yerbas.” *Muyal* in Maya means “cloud.”

16. *Pax*.—The principal feast in this month was called *pacum Chac*, the recompense or repayment of *Chac*, the gods of rain. The name was probably derived from this term; though it may be from *pa.rah*, to play upon a musical instrument, as Pio Perez suggests, with reference to the music of the festival.

17. *Kayab*.—From *kay*, to sing, to warble; applied both to persons and birds. No festival is assigned to this month.

18. *Cum ku*.—Translated by Pio Perez as a loud and distant noise like thunder, etc. No such derivation is supported by the old authorities. *Cum*, in Maya, is an earthen jar or pot, Nahuatl, *comill*; *cum ku* is the potter's furnace in which such jars are burned (*Dicc. Motul*); but as *ku* also means “god,” *cum ku* is the god of the vase or jar, the deity so often represented in Maya and Nahuatl art, reclining on his back and holding a vase in the centre of his stomach (Le Plongeon's *Chac mol*, etc.). He was the god of the rains, this month being at the height of the rainy season.

THE TZENTAL MONTHS.

The original authority for the names of the Tzental months is Fr. Juan de Rodaz, in his *Arte de la Lengua Tzotzlem ó Tzincanteca*, 1688, MS., a copy of which was in the possession of the late Abbé Brasseur de Bourbourg, but which I have not seen. It would appear that the Zotzils and Tzentials had the same month-names. We have, further, the testimony of a Mexican writer, Emetorio Pineda, who says that at the time he wrote, 1845, the natives continued to divide the solar year into eighteen months, the names of which he gives.* Their use, he states, was to arrange for their agricultural operations, and to fix the dates for their overt or secret religious rites.

* Pineda, *Descripcion Geografica de Chiapas y Soconusco*, pp. 111, sq. (Mexico, 1845).

The order and the names which he gives are as follows :

Months of the Tzental Calendar.

1. Tzun.	10. Elech.
2. Batzul.	11. Nichquin.
3. Si sac.	12. Shan viniquil.
4. Mucta sac.	13. Xchibal viniquil.
5. Moc.	14. Yoxibal viniquil.
6. Olalti.	15. Xchaubal viniquil.
7. Ulol.	16. Poin.
8. Oquinajual.	17. Mux.
9. Vch.	18. Yan kin.

Derivation.

1. *Tzun*.—Allied to the Maya *chun*, the beginning; *dzunul*, to begin; so called from being the first month of the Tzental year (about April 1). Or from Zotzil *tzunel*, to sow (sembrar, Ferraz, *Lenguas Indigenas de Centro-America*, p. 57).

2. *Batzul*.—The Tzental word *batz* means a species of monkey which make a howling noise and are bearded; *batzil* means native, as opposed to foreign, e.g., *batzil tuh*, a knife of native manufacture; but I would not derive the month-name from either of these; rather from *bat*, the word in Tzental and Maya for grain, seed, etc., referring to the month in which the seed-corn was prepared.

3. *Si sac*.—For *tzi zac*, “little white;” probably, as in the Quiché Calendar, from the blossoming of certain white flowering plants at this time.

4. *Mucta sac*.—“Great white,” referring to the increasing abundance of flowers.

5. *Moc*.—Pineda says this signifies the month in which the fences of the cornfields were made. It is evidently the Maya *moc*, to fasten together, whence the Tzental *macteibil*, wooden fence (cercado de palos, Lara, *Vocabulario Tzental*).

6. *Olalti*.—This and the two following months were those in which the corn was planted. Both *olalti* and *ulol* appear

related to the noun *anal*, planting, and the verb *sanalighon*, to plant. In Zotzil *obolak'* is to produce, to bring forth.

7. *Ulol*.—See the preceding name.

8. *Oquinajual*.—Probably “the planting time.” from *anal*, planting, and *quin*, time, day, season.

9. *Veh* or *uch*.—Pineda's note here is: “In this month the plants are attacked by diseases.” The name is plainly from the verb *uchel*, applied to the premature falling of leaves and fruits (caerse la semilla y granos y las hojas de los arboles, Lara, *Vocabulario*).

10. *Elech*.—Pineda remarks, “the healthy winds arrive.” The name is a compound of *ochel*, west, and *ihc*, wind, these being dry and salubrious.

11. *Nichquin*.—This name, observes Pineda, “indicates the flowering season.” It is the Tzental word *nichim*, flowers, from *snich*, to flower, and *quin*, day, season.

12. *Sban viniquil*.—The word *viniquil*, *viniquilel*, or *vinaquin* means time, period or season. This and the three following months, called respectively the first, second, third and fourth seasons, are understood by Pineda to refer to the four periods of the growth of the maize, the first that of fecundation, the second of the formation of the grain, the third when it is in milk, the fourth when the grain hardens. This seems an error, as it does not require in that latitude eighty days for these changes after the fecundation of the ear. No doubt it refers to the ripening of the various plantings, and so the expressions are understood by Lara: “*ox vinaquin ixim*, mais que se hace en 60 dias.”

13. *Xchibal viniquil*.—“Second season.” See above.

14. *Yoxibal viniquil*.—“Third season.” See above.

15. *Xchanbal viniquil*.—“Fourth season.” See above.

16. *Poin*.—“In this month,” observes Pineda, “the beehives should be emptied and the harvests gathered.”

17. *Mux*.—"This name," says Pineda, "indicates the approach of cold." This suggests a derivation from the Tzental *q'muc ba*, to cover one's self; which is confirmed by the similar meaning of the Cakchiquel month-name, *Pariche*, which see.

18. *Yax quin*.—From *yax*, green or new; *quin*, day or season. Pineda remarks that it is the season of Easter, thus showing that the Tzental year began about April 1.

THE CAKCHIQUEL MONTHS.

The names of the Cakchiquel months are furnished by several old authorities, as by Father Varea in his *Vocabulario*, MS., and Father Coto in his similar work.* There are also extant several native Cakchiquel Calendars, a careful copy of one of which, bearing the date 1685, is in my possession.

The names of both the Cakchiquel and Quiché months, with proposed translations, were published by Señor Gavarréte in his school Geography of Guatemala, edition of 1868, but this portion is omitted in all other editions of that work.†

There is considerable confusion in the Spanish authorities about the sequence of the Cakchiquel and Quiché months; for this reason I have not followed any of them, but have adopted the sequence as given in the Calendars in my possession composed and written by the natives themselves.

Months of the Cakchiquel Calendar.

1. Tacaxepual.	10. Rucab tok'ik'.
2. Nabey tumuzuz.	11. Nabey pach.
3. Rucab tumuzuz.	12. Rucab pach.
4. Cibixic.	13. Tziquin k'i'h.
5. Uchum.	14. Cakan.
6. Nabey mam.	15. Ibota.
7. Rucab mam.	16. Katic.
8. Lik'in k'a.	17. Izcal.
9. Nabey tok'ik'.	18. Pariche.

*Both these MSS. are in the Library of the American Philosophical Society, Philadelphia.

† *Geografía de la República de Guatemala*, p. 82. Segunda Edición (Guatemala, 1868).

Derivations.

1. *Taca repual*, or *Tecorepual*, or *Teque repual*.—The best authorities agree that this was the first month of the Cakchiquel year, and the first corn planting (*tiempo principio de año ó tiempo de sembrar las primeras milpas*. Varea, *Vocab.*, MS.). The word is clearly a corruption of the name of the second month in the Nahuatl Calendar, *Tlaca Xipeualiztli*.

2. *Nabey tumuzuz*.—The first *Tumuzuz*. Father Varea states that this month was at the beginning of the winter rains, and that it derived its name from a species of flying insect which then made its appearance (*viene quando empiezan los primeros aguaceros del invierno*. Aparean y andan volando unos gusanillos que llaman *tumuzuz*. *Vocabulario*, MS.).*

3. *Rucab tumuzuz*.—The second *Tumuzuz*.

4. *Cibivic*.—From *cib*, smoke, mist or vapor. Varea observes that the natives were accustomed to plant in this month, and that it follows *tumuzuz*. It derived its name from the smoky appearance of the atmosphere at this season, or from the custom of burning brush in clearing the ground. Compare the Maya month *Kan kin*.

5. *Uchum*.—"Season for replanting." Father Coto describes it as the month for planting gardens (*bueno para hacer almagos y sembrar ortaliza*. *Vocabulario Cakchiquel*, MS.). The derivation is obscure. The root *uch* means a species of fox; a louse; gum copal; and chills and fever. In the neighboring dialect of the Tzotzils, *uchum* means to grind in a mill, from which *ghuchumbil*, a corn mill (*moler*, *molino*).

6. *Nabey mam*.—"First old man." In most of the dialects *mam* means the maternal ancestor. Here the word is used metaphorically in the sense "prematurely old," because the corn planted in this and the following months ripened prema-

*Dr. Stoll (*Ethnologie der Indianerstämme von Guatemala*, s. 60) found the swarming times of the termites, *Culotermes castaneus*, in Guatemala, to be March 22 and May 21, dates which do not coincide with the Calendar. He omits, therefore, the former, and refers to an occasional flight about the middle of June.

turally, and did not reach full growth; and they believed the same was the case with animals born at this time (tiempo de revejidos, porque no crecia muy alta la milpa que por este tiempo se sembraba, y aun las criaturas que nacian. Note to the Calendar). Doubtless it was for this reason that, as Father Varea tells us, both months of *mam* were regarded as of evil portent, and the natives were accustomed to say: *Itzel k'ik ca vinak k'ih mam*, "they are bad days, the forty days of mam." *Vocabulario*, MS.

7. *Rucab mam*.—"Second old man."

8. *Lik' in k'a*.—"Soft to the hand," from *lik'*, soft, and *k'a*, hand. The expression refers to the soil which was then soft owing to the rains (tiempo en que esta la tierra blanda y resbalosa por las muchas aguas. Note to the Calendar).

9. *Nabey tok' ik'*.—"The first cacao harvest," from *tok'*, the cacao harvest (cosecha de cacao, Ximenes. *Vocabulario*, MS.).

10. *Rucab tok' ik'*.—"The second cacao harvest."

11. *Nabey pach*.—"The first hen hatching." (Tiempo de empollar las cluecas. Note to the Calendar.) The name is from the verb *pache*, to brood, to set as a bird (Ximenes).

12. *Rucab pach*.—"The second hen-hatching."

13. *Tziquin kih*.—"The season of birds," from *tziquin*, bird, *k'ih*, day, time, season.

14. *Cakan*.—Derived from *k'ak*, red; according to the Cak. Calendar from the reddish clouds (celages rojas) often seen at this season; according to others, and more probably, from a species of red flowers which blossom at this time.

15. *Ibota*, or *Obota*, or *Botam*.—A note to the Calendar says: "The season of various colors, or, of mats rolled up." In the latter sense the name would be from the verb *bot*, to roll up, *botal*, that which is rolled up (lo arollado como petate. Guzman, *Vocabulario*, MS.). Gavarrete gives "rollo de estera," a roll of mats. The signification is not clear.

16. *K'atic*, or *Qatic*.—This is explained in a note to the Calendar as “pasante ó siembra comun.” The derivation suggested would be from *k'atoh*, a banquet, a festival, and to invite to such.

17. *Izcal*, or *Itzcal*.—Translated in the Calendar as “the season of sprouts or of throwing out shoots” (retoñar ó echar primipollos). The word is undoubtedly the Nahuatl *Itzcalli*, the name of the eighteenth month in the Mexican year. Its signification is “renewal,” or “resurrection,” or “growth;” this is indicated in the application of the word in the Cakchiquel Calendar.

18. *Pariché*, or *Payriché*.—“The season for covering, in order to protect one’s self from the cold,” says a note to the Calendar. The derivation is from *parah*, the covering of palm leaves used to protect a person from the rain; and *che*, tree or wood. The same idea is conveyed in the Tzental month-name *Muc*. Gavarette’s explanation, “firewood,” from *che*, wood, and *parquii*, bushes or small trees, is not tenable.

THE QUICHÉ MONTHS.

Although there was little difference between the Quiché and Cakchiquel dialects, their month-names varied in several instances. Our sources of information concerning the Quiché names are authentic, several of their Calendars dating from the seventeenth century having been preserved. From these Gavarette published a list in the work already referred to, and I have in my possession a copy of a native Calendar in the Quiché dialect written about 1722.

Months of the Quiché Calendar.

1. Tequexepual.	10. Ucab pach.
2. Tziba pop.	11. Tzizi lakam.
3. Zac.	12. Tziquin k'ih.
4. Ch'ab.	13. Cakam, or Cakan.
5. Nabey mam.	14. Botam.
6. Ucab mam.	15. Nabey zih.
7. Nabey lik'in k'a.	16. Ucab zih.
8. Ucab lik'in k'a.	17. Rox zih.
9. Nabey pach.	18. Chee.

Derivations.

1. *Teque.repual*.—See Cakchiquel months, No. 1.
2. *Tziba Pop*.—"Painted mat." Compare the Maya name for their first month.
3. *Zac*.—"White." The same as the eleventh Maya month, but with the Quichés it probably referred to certain white flowers blooming at this season.
4. *Ch'ab*.—Gavarrete translates this as "bow," which is, in fact, the meaning of *chab*;* but I have no doubt that the right word is *ch'ab*, from *ch'aban*, mud, mire, from the muddy condition of the soil at this season.
5. *Nabey mam*.—See the sixth Cakchiquel month, of this name.
Gavarrete inserts as the fifth month, between *Ch'ab* and *Nabey mam*, a month named *Hun bix k'ih*, "the season of the first singing" of certain birds, or, "of the first fires," *bix* having both these significations. He omits the name of *Botam* for the fourteenth month, and thus preserves the proper number.
6. *Ucab mam*.—The second *mam*. See above.
7. *Nabey lik'in k'a*.—The first *lik'in k'a*. See the Cakchiquel month of this name.
8. *Ucab lik'in k'a*.—The second *lik'in k'a*.
9. *Nabey pach*.—The first *pach*. See the Cakchiquel month of this name.
10. *Ucab pach*.—The second *pach*.
11. *Tzizi lakam*.—*Tzizi*, from *tzizil*, the small sprouts or shoots which begin to appear; *lakam* means flags, or banners, and seems to refer to the shape or appearance of these.

*In the Quiché, Cakchiquel, Pokomam and Pokomchi dialects, *chab* means both "bow" and "arrow." Strictly it means the bow only, the arrow being *al*, or *yal chab*, "son of the bow."

12. *Tziquin zih*.—"Season of birds." See the Cakchiquel month of this name.

13. *Cakam*.—See the Cakchiquel month of this name.

14. *Botam*.—See the Cakchiquel month *Ibola*.

15. *Nabey zih*.—The first *zih*. The word is explained as a tree which bears abundant white flowers and blossoms at this season. Gavarrete gives erroneously *Tzih*, "word."

16. *Ucab zih*.—The second *zih*.

17. *Rox zih*.—The third *zih*.

18. *Chce*.—Trees or wood. See the Cakchiquel month *Pariche*.

THE CHAPANEC CALENDAR.

The Chapanecs of Chiapas, belonging to a linguistic stock wholly different from the Mayas, Nahuas or Zapotecs, also made use of this Calendar. This we know from the fact that they counted 18 months to their year, each of twenty days, and allowed five intercalary days, called *ubu*, precisely as did the Nahuas and Mayas.

It is peculiarly unfortunate that we have not the names of their days, and those of their months are preserved in a sadly imperfect manner. Mr. Alphonse Pinart has published two lists, both incomplete, at the close of his edition of the *Arte de la Lengua Chiapaneca*, of Fray Juan de Albornoz; but they do not seem to have constituted a part of that work; at least they are not in the MS. copy of it in my possession.

It would not be difficult for a person acquainted with the climate and routine of culture pursued by the Chapanecs to construct from these two lists one which would be accurate and complete, but as I do not possess that knowledge, I give them as they are, so as to complete this portion of my study. I add, in some instances, possible derivations, from the MS. Chapanec Vocabulary of Dr. Berendt, but in most cases the etymology of the names is quite obscure.

Months of the Chapanec Calendar of Chiapa.

1. May 15. *Tumugûi*, or *Tamugûi*.—"Chile is sown." Begins May 15.
2. June 4. *Iatati*, or *Hatati*.—"The winds begin."
3. June 24. *Ñumbi*.—"Magney is sown."
4. July 14. *Cutamé*.—"The weather changes."
5. August 3. *Iaumé*, or *Haumé*.—"Dampness."
6. August 23.
7. September 12. *Majua*, or *Mahua*.—"Cold."
8. October 2.
9. October 22.
10. November 11. *Mua*.—"Camotes (batatas) are planted." In Chapanec these are called *nua*.
11. December 1. *Tupiu*.—"The dampness increases." Probably from *tipi*, mist or fog.
12. December 21. *Tuhu*, or *Tujiu*.
13. January 10. *Muhu*, or *Mu-u*.—"Mosquito time."
14. January 30. *Turi*.—"Ripeness."
15. February 19. *Manga*.—"Time for little fishes" (fish, *nangasi*).
16. March 11. *Puri*.—"The jocote ripens" (jocote, *luri*, *Spondias edulis*).
17. March 31. *Cuturi*.—"The jicalpestle (gourd) ripens."
18. April 20. *Cupané*.—"The coyol (*Bactris vinifera*) ripens."

Months of the Chapanec Calendar of Su-Chiapa.

1. June 4. *Yucu*.
2. June 24. *Ñumbi*.—"Magney is sown."
3. July 14. *Muhu*.—"Mosquito time."
4. August 3. *Hatati*.—"The winds begin."
5. August 23. *Mundju*.—"Chile is sown."
6. September 12. *Catani*.—"The rains cease. Maize begins."
7. October 2. *Manga*.—"Fishing begins."
8. October 22. *Haumé*.—"Rivers fall, and fish leave."
9. November 11. *Mahua*.—"Cold begins."
10. December 1. *Toho*.—"No planting done."
11. December 21. *Mua*.—"Camotes are planted."

12. January 10. *Topia*.—"The dampness increases."
13. January 30. *Tumahu*.—"Nothing is done."
14. February 19.
15. March 11. *Cujamé*.—"The coyol ripens."
16. March 31. *Pari*.—"The jocote ripens."
17. April 20. *Pahuari*.
18. May 10. *Turi*.—"Time of ripening."

§ 13. THE SYMBOLISM OF THE DAY NAMES.

Whatever other uses of an astronomical and time-measuring character the Calendar had, the best known and most general service which it rendered was for divinatory purposes. Indeed, early writers, such as Sahagun and Cordova, assert that the ritual Calendar of 260 days was confined to this object.

Unfortunately, they have not left us precise details. For in spite of a large amount of desultory information in their works and those of other early writers, the basic theory of the art of divination, according to this Calendar, is nowhere stated. I propose to offer a suggestion as to what this was, as appears to be indicated by the Calendar itself, and to be supported by a number of collateral facts mentioned by early authorities.

The period of 20 days, each bearing its own name, was certainly derived from the vigesimal system of counting. This was in use in precisely the same manner in all those of the linguistic stocks under discussion. In all, the unit of the higher integers was 20.* This multiplied again by 20 gave 400, and this again by 20 gave 8000, which in each was the highest number for which they had a single expression.

This number 20 was based on finger-and-toe counting, and so clearly was this reflected in the languages that in Nahuatl it bore the name *cem poualli*, "one (whole) count;" in Tzental *hun vinit*, "one man;" and in Quiché and Cakchiquel, *vinak*, "a man" (homo). The Maya *kal*, and the Zapotec *cal-le*, appear to have the signification "completed," "filled up," referring to the completed count of fingers and toes.

In this manner the number 20 came to represent symbolically

*The vigesimal (quinary-vigesimal) system obtained in most of the stocks of Mexico, Central America and Northern South America. North of Mexico it is rarely found, as among the Tinkit and Pawnees. Elsewhere the decadal plan is in vogue (see Müller, *Grundriss der Sprachwissenschaft*, Bd. ii, Ab. i, s. 183).

the whole of man, his complete nature and destiny, and, mystically, to shadow forth and embody all the unseen potencies which make or mar his fortunes and his life.

I have already spoken of the various theories to account for the 13-day period. Whatever one we accept, I am persuaded that this period was posterior and secondary to the 20-day period. At any rate, it was distinctly so regarded in the divinatory systems. Cordova, speaking of the Zapotec Calendar, which was certainly the most primitive in form, tells us that each of the 20 signs had not only 13 numbers each, but 13 names, or rather 13 varieties of the same name.*

In the region of the Tzentals, Bishop Nuñez de la Vega describes as a common figure in their books of divination the demon *Coslahuntox*, who was painted in a sitting position and with horns on his head, his name meaning "the demon with 13 powers." †

In this garbled account we must correct *Coslahuntox* to *oxlahun tox*, "the thirteen divisions" or "parts;" ‡ and the "horns" to the plumed headdress of quetzal or other feathers.

Just such seated and crowned figures are found on sculptures from the ancient cities of Ocozingo and Palenque, in the territory of the Tzentals; one from the latter seated on a double-headed tiger, and another from the former where the tiger is conventionalized into an elaborately carved block of stone. § These, and others like them, represent the divinity of the day, seated with empty hands to show that he is a ruler and is not required to labor, precisely as the early missionaries tell us was the native idea of sovereignty among those peoples. ||

* "Cada uno de aquellos animales que eran veynte tenia trece nombres, y aunque todos estos trece nombres eran en si como una cosa, diferenciavanlos con les añadir ó quitar letras." Cordova, *Arte de Lengua Zapoteca*, p. 203.

† "Al que llaman Coslahuntox (que es el demonio, segun los indios dicen con trece potestades) le tienen pintado en silla y con astas en la cabeza como de carnero." Nuñez de la Vega, *Constituciones Diocesanas*, p. 9.

‡ The Tzentel verb *q'tox* means to divide, to separate, to split. See above, note to page 281.

§ The figure from Ocozingo is given by E. G. Squier in his *Observations on the Chacthiuilt of Mexico and Central America*, p. 11 (New York, 1839). The bas relief from Palenque is familiar from the works of Stephens, Charnay and others. In the Museum of the Trocadero, Paris, are several small seated figures of a similar character, some bearing a day sign upon. They were collected by M. Pinart in Tzentel territory, and have by some been remarked upon as similar to the seated statues of Buddha. I take them to be of the same class with the images just mentioned.

|| See the remarks of Father Coto in his *Diccionario de la Lengua Cakchiquel*, which I quote in my *Essays of an Americanist*, pp. 115, 116, note (Philadelphia, 1890).

That the same allocation obtained among the Nahuas is testified to by Sahagun, whose words are, speaking of the divinatory Calendar: "It was composed of 20 signs. . . . To each sign were allotted 13 days." He adds: "This method of divination has nothing to do with natural astrology, or the movements or aspects of the planets, but takes as its point of departure certain signs and numbers which are not derived from natural phenomena, but must have been invented by the Devil himself." "They asserted this system was a divine revelation from Quetzalcoatl; it consisted of 20 signs, each multiplied 13 times."*

This writer dilates more than any other on the details of the Nahuatl divinatory system, but leaves his readers in the dark why the individual signs were chosen, or what their relation to each other and the general system was supposed to be.

I do not pretend to be able fully to supply this regrettable lacuna in our knowledge of the philosophy of these ancient nations. But I believe that their system was in a certain sense philosophic; that it grew out of ripe meditation on the agencies which direct and govern life; and that it was merely veiled—not smothered—in the symbolism which has been transmitted to us, and which they found it convenient to throw around it, in presenting it to the unlearned.

The 20 potencies or agencies, fixed at that number for the reason above given, follow each other in the sequence in which they were believed to exert their influence on the life or existence not of man only, but of things and of the universe itself. This opinion exerted a strong constructive and directive influence on the national myths, rites, and symbolism, extending to architecture and ornament, to details of government, and to the everyday incidents and customs of national and domestic life. In all of these we perceive a constant recurrence of the signs and their correspondent numbers, drawn from the composite relations of 20 : 13.

Turning to the symbolic meaning which may be discovered in the signs and names of the twenty days, I shall examine each briefly :

Day 1.—The Swordfish, Crocodile, Spiderfish or other "Marine Monster."

According to the Codex Fuenleal, at the beginning of things the gods made thirteen heavens, and beneath them the primeval

* Sahagun. *Historia de la Nueva España*, Libro iv, *passim*.

water in which they placed a fish called *cipactli* (que es como caiman). This marine monster brought the dirt and clay from which they made the Earth, which therefore is represented in their paintings resting upon the back of a fish.

This sign, therefore, signifies the material beginning of existence or life in the Earth or in the individual, the substance into which it is shaped.

The *cipactli* was an entirely mythical creature, and was not intended to represent any known species.* Therefore any curiously shaped fish was selected. The word has been variously interpreted, but none of the renderings seems appropriate.† I would suggest that it is a compound of *ce*, one the whole, and *patia*, to liquefy, to become water, which is in full concordance with the native myth of creation above referred to.

Day 2.—Wind or Air, Breath, Spirit, Soul.

In American symbolism air or wind constantly signifies the immaterial life, that which exists apart from physical substance.

The first two of the twenty symbols therefore point to the double origin of being conceived as matter and spirit, body and soul, extension and thought.

Day 3.—Night, Darkness, the House.

The symbolic idea underlying these signs is that of repose. Night is the time for sleep, the house is the place of rest, darkness suspends labor and relaxes effort. Old age and the harvest close, the one the activities of the career, the other the toil of the agriculturist.

Day 4.—The Lizard, the Iguana.

The flesh of the iguana was a favorite article of food, and the animal was taken as the symbol of nutrition and abundance. Among the Pipils the god of maize and the food supply presided over this sign and its signification was plenty and fullness.‡

* This is also the opinion of Orozco y Berra. *Hist. Antigua de Mexico*, Tom. i, p. 54.

† Several may be found in Boturini, *Idea de una Nueva Historia General*, p. 46.

‡ Nuñez de la Vega, *Constituciones Diocesanas*, p. 10, and *Codex Telleriano-Remensis*, Lam. xiii (in Kingsborough's *Mexico*).

Day 5.—The Serpent.

Dr. Seler thinks that the signification of this symbol is poverty or want. According to Pedro de los Rios, however, the serpent, in Mexican symbolism, represented especially the phallus and therefore the reproductive force, the sexual life.* Of course, here as in other symbolisms, this animal conveyed many other meanings; but there is reason to suppose this was the one especially intended in this relation.

Day 6.—Death, the Severed Head, the Skull.

The chief signification of this sign illustrates the notion of "counter-sense" which so often occurs in language, mythology and folk-lore. Modern dream-lore says that dreams before midnight "go by opposites," that is, they must be taken opposite to their obvious purport. This theory of contrasts is based on some idea of compensation, or else on that of esotericism, which "least does mean, what it most does show."

In accordance with this plan, the meaning of this sign in Nahuatl symbolism was chiefly, not death, but birth. The goddess of parturition, Tonacacihuatl, was patroness of the day; and the snail shell, typical of the womb (for out of it, as the snail from its shell, emerges the neonatus), was her emblem; to which may be added the sad and close connection which often exists in child-bearing between birth and death (of the mother).

The intimate relation of this to the preceding sign, and the natural sequence thus established, will be evident.†

Day 7.—The Deer.

The signification of this symbol is obscure. According to some of the interpreters, it meant drought; but its patron among the Aztecs was Tlaloc, the god of the rains. The Nahuas of Nicaragua, on the other hand, explained this sign as representative of success in hunting.‡

* De Rios, in his notes to the Codex Vaticanus, in Kingsborough's *Mexico*. The phallus was a prominent object of worship in ancient Mexico. See Tayrayre, *Explor. des Regions Méridionales*, p. 233, and other modern authorities.

† The contrasted meaning of this sign is fully recognized by Dr. Seler (*Utzek. und Maya Handschriften*), though he fails to see its relation to the sign preceding it.

‡ Oviedo, *Historia de Indias*, Tomo iv, p. 55.

Day 8.—The Rabbit, the Seed, the Flower Garland.

As the former sign seems to indicate fortune in the chase, so does this one in cultivating the fields. The figure in the full moon was called by the Nahuas "the rabbit;"* the animal also symbolized ease, idleness, and especially drunkenness. The god of drunkards bore this name.† This, however, must have been a later application, as the intoxicating pulque was known in but a limited area and probably its invention was much later than the adoption of the sign.

This and the previous sign seem to refer to the two chief sources of the food supply, hunting and agriculture.

Day 9.—Water, Thunder-storms.

The rains may be regarded as the agents of productiveness and the creators of fertility; or, on the other hand, as those which bring gloomy, sunless days, dampness, chilliness, rheumatic pains, coughs and disease. The thunder terrifies, the lightning destroys, the floods overwhelm.

It is from the latter aspect that water is contemplated in this sign. It represented sickness and desolation. Hence, among the Nahuas, it was deemed ominous of evil and its patron was the yellow-visaged god of fire, Ixcocauhqui, indicative of its desolating portent.

Day 10.—The Dog, the Stealer.

The dog among the Nahuas was held in small esteem, and was badly treated. "A dog's life," with them, as with us, meant a miserable one. Their verb *itzcuinizcallia*, "to be brought up like a dog," conveyed the same ideas of bad treatment and hardship that the phrase does among ourselves. A very common locution in Nahuatl to signify affliction is *in tell, in quahuil*, "with stick and stone," as one treats a dog.

The dog was closely associated with the notion of death; the Nahuatl patron of the day was the god of hades, Mictlantecutli, and he was painted with a man in the last stages of misery fol-

*As do now the common people of India and some Mongolian tribes. See Grimm, *Teutonic Mythology*, p. 716 (Eng. Trans.).

† See my *Sacred Songs of the Ancient Mexicans*, p. 61 (Philadelphia, 1890), for an illustration of the "Totochtin," or rabbit gods of drunkenness and a hymn to them taken from the unpublished MSS. of Father Sahagun.

lowing him. The animal holds the same relation in the Maya hieroglyphs.*

The sign of the dog, therefore, denoted hardship and suffering.

Nevertheless, by the concurrent testimony of Sahagun and Duran, both this and the following day sign were deemed peculiarly prosperous and fortunate. Children born on them would arrive at positions of dignity and importance and shed lustre on their families. The notion would seem to be that such would overcome all difficulties.

Day 11.—The Monkey.

The monkey, like the dog, was a domesticated animal among some of the Nahuatl and adjacent tribes. Father Sahagun narrates the artifices adopted to catch them while young for the purpose of taming them.† There seems a purpose in placing these two domestic animals side by side in the Calendar. They were both highly auspicious signs, and indicated successful contest with obstacles.

Day 12.—The Broom, Teeth or Points.

The twisted brush of mallinalli grass or of the sharp *itztlaitl* was probably the symbol intended by this sign, whether referred to as "the thing twisted," or "the thing with many points."

Its meaning is obvious. As that which is swept away is dirt and dross, lost to sight and discarded, it has been recognized by most of the old writers that the significance is the evanescence, the transitory character, of earthly possessions.‡

Day 13.—The Reed or Cornstalk.

In Tzental and Maya it is distinctly the dry and dead cornstalk, *cagh-ben*, which corresponds to the Nahuatl patron of the day, the god of cold and dryness, Itztlacoliuhqui.§ The sug-

* See Dr. Schellhas' observations and references in *Zeitschrift für Ethnologie*, 1892, pp. 119, 120.

† *Historia de Nueva España*, Lib. xi, cap. i, sec. 5.

‡ "Symbol der Vergänglichkeit, Unhaltbarkeit, des Dahinsterbens." Seler, "Das Tona-hamatl," in *Compte-Rendu* of the Congress of Americanists, Eighth Session, p. 591 (Berlin, 1890).

§ Literally, "pinched or bent with cold," applied also to a peculiar headdress designating thús. Sahagun, *Hist. de Nueva España*, Lib. ii, cap. xxx. I prefer the derivation of this word from *itzlic*, cold, as given by Simón, to the more remote one from *itzli*, obsidian, offered by Seler.

gestion distinctly is of advancing years with the loss of the vital warmth of youth.

Day 14.—The Tiger (Jaguar), or Sorcerer.

According to the *Annals of Cuauhtitlan* the tiger symbolized the nocturnal heavens dotted with stars as the jaguar skin with spots.* That this was the significance of this day sign receives added probability from a figure in the Codex Borgia, where the goddess of the sign is accompanied by a picture of the moon and the night sky sown with star-points.†

The moon and the stars were the especial field of study of the seers, the sorcerers and the wise men; hence the underlying meaning of the sign was occult or mystical knowledge.

The especial constellation known to the Nahuas as *ocelotl* was the Great Bear; it mythically represented the god Tezcatlipoca deposed from his position as the sun god, and falling into the sea. ‡

Day 15.—The Eagle, the Bird, Knowledge.

In the Nahuatl symbolism the eagle, *quauhtli*, is generally understood to mean "war." But this sign in the other languages would seem to stand for knowledge or skill.

Day 16.—The Vulture, or Owl.

According to the Nahuatl interpreters, this is the sign of old age, of long life, derived perhaps from the bald head of the vulture. The owl in all these nations was regarded as a bird of evil omen. We may understand the reference in both to be to the infirmities and losses of old age.

Day 17.—Strength, Motion.

The idea apparently conveyed by this sign is the disastrous results of strength exerted. It is in the myths connected with earthquakes, eclipses and the end of the world, and its representations portray death, human sacrifice, and destruction. The

* See *Anales del Museo Nacional de Mexico*, Tom. ii, p. 254.

† Given by Dr. Scler, *Attek. und Maya Handschriften*, p. 25, who, however, derives a different meaning from it.

‡ See Orozco y Berra, *Historia Antigua*, Tom. i, cap. ii.

motion is the shaking, tottering movement of the paralyzed or the aged, or that of the earth in its convulsions.*

Day 18.—The Flint Knife.

What is intended is the sacrificial knife or the spear point, stained with blood as an instrument of death. The suggestion is death in war, or as a victim.

Day 19.—The Lightning.

In this sign the thunder-storm was considered as the begetter of sickness, and, like water, as portrayed under the ninth day sign, the maleficent effects of the thunderbolt, the pouring rain and the floods were those intimated. The interpreters considered it, therefore, a day of evil omen.

Day 20.—The Chieftain, the Flower.

As previously stated, the real symbol of this day was the sun. This is to be understood in its mythical sense as the haven of life, the place of repose of souls, the resting place of the dead: as I have stated in general terms in a previous work, "The home of the Sun is the heaven of the Red Man."† This is true all over the continent, and there is a peculiar significance in finding it borne out by the symbolism of this remarkable Calendar.

§ 14. GENERAL SYMBOLIC SIGNIFICANCE OF THE CALENDAR.

Restoring the figurative terms to their literal meaning, we may conclude that the general and original symbolism of the day names in all the tongues in which we have them were as follows:

DAY.	SYMBOL.	MYTHIC SIGNIFICANCE.
1.	Swordfish.	Birth, the beginning.
2.	Wind.	Breath, life, the soul.
3.	Darkness, the house.	Sleep, rest, repose.
4.	Iguana.	Food, nourishment.
5.	Snake.	Sexual life, reproduction.

*The present (the fifth) age of the world, according to Mexican mythology, was expected to end in this sign. *Codex Telleriano-Remensis*, Lam. x.

† See my *Myths of the New World*, Chap. ix, for abundant testimony on this point.

DAY.	SYMBOL.	HIERATIC SIGNIFICANCE.
6.	Death.	Child-bearing, children.
7.	Deer.	Hunting.
8.	Rabbit, seed.	Agriculture.
9.	Water, rain.	Illness (or, productiveness).
10.	Dog.	Hardship and suffering (success through them).
11.	Monkey.	Difficulties surmounted.
12.	Broom, teeth.	Loss, evanescence.
13.	Reed.	Cold, drought, advancing years.
14.	Tiger.	Learning, wisdom.
15.	Eagle, bird.	Knowledge, skill.
16.	Vulture, owl.	Old age, misfortunes.
17.	Motion.	Debility, failing powers.
18.	Flint knife.	War, death.
19.	Lightning.	Sickness, destruction.
20.	Sun.	The house of the soul.

An examination of this sequence here exhibited, which is in the main accurate, though doubtful in some specifications, reveals that it was intended to cover the career of human life, from the time of birth until death at an old age.

The individual emerges from the womb of his mother and the parturient waters, as did the earth from the primeval ocean; he receives breath and with it life, which is supported by repose and food. The man reproduces his kind; the woman, at the risk of death, brings her child into the world. The chase and tilling the ground are the leading occupations of peace, and he who holds firm through illness, suffering and hardships, will gain the prizes of life. Having reached the acme of his career, the decline commences. Losses multiply, years increase, and though knowledge and wisdom are augmented, old age comes on apace with failing powers, with vanquished struggles, with sickness and death; until at last, its course run, its task completed, the soul quits the worn-out body and soars to its natural haven and home, the abode of the Sun.

Such, it seems to me, without any straining, is the philosophical conception of life which was intended to be conveyed by the symbols of this strange old Calendar. They may not have originated contemporaneously with it; certainly not, if it was primarily deduced from astronomical observations; but quite probably, if, instead of this, it was built on terrestrial relations and mythical concepts.

In the twenty headings under which the agencies which influence human life were arranged, the ancient seers believed they had exhausted the arithmetical unit which stood for the completed individual—his vigesimal equation and correlate; in the thirteen modes of activity which they assigned to each of these agencies, they had taken into account the thirteen possible relations of each to both the material and immaterial worlds; and the fact that the result of 20×13 expressed in days gives approximately nine lunar months, the period required for the unborn babe to pass through its evolution from conception to birth—a period perfectly familiar even to the wild hunting tribes—gave them whatever needed confirmation they wished for the mystic potencies of these cardinal numbers.

The Great Mesozoic Fault in New Jersey.

By Benjamin Smith Lyman.

(Read before the American Philosophical Society, September 15, 1893.)

Great faults, the ever-ready, easy resource of geologists to cover up their own deficiencies or mistakes, have, without any substantial proof, been liberally conjectured again and again to account for what has been supposed to be a wholly impossible apparent thickness of the older Mesozoic rocks of New Jersey. For those rocks have, from their conformability throughout, and their predominant color and a comparative lack of fossils through a great part of them, been commonly lumped together as only a single group, formation, or system, under the general name of New Red, or Triassic, or Jurassico-Triassic, or Rhaetic. Nearly forty years ago, with the bold assurance born of ignorance, perhaps quite pardonable at that time, the special name of Newark group was proposed for the whole lot, from one of its most striking local economic features, though otherwise an extremely subordinate one, and even economically perhaps inferior to the Richmond coal; and latterly there has been an effort to revive the name, long after it had fallen into well-merited oblivion. The assumption has been: the whole series is but one formation; one formation can be no more than about 5000 feet thick; therefore, the whole series is at most 5000 feet thick.

It now appears, however, from recent researches in course of publication by the Geological Survey of Pennsylvania, that the total thickness of the so called New Red does incontestably far exceed the thickness

usually given to any single formation ; but, on the other hand, that there is no sufficient reason yet to believe that all the rocks do belong to one paleontological group or formation. The comparatively few fossils found have hitherto been ascribed indiscriminately to the whole so-called formation, without any exact knowledge of the relations of beds of different localities to one another. Perhaps too great reliance has been placed in the capacity of fossils to indicate the geology of a vast series of beds in great measure devoid of them ; and the more laborious, purely geological methods of combining numerous observations of dip, strike and elevation, with the help of topographical indications, have long been neglected, because there was likely to be no sufficient immediate economic return.

At length, however, the series has been practically worked out by proceeding throughout from one exposure to another near it ; instead of simply assuming a nearly constant dip in one northwesterly direction and estimating the consequent total thickness from the whole breadth of the region filled by the beds. It has now become possible to ascertain from what part of the series the different fossils of the region have come, at least in Eastern Pennsylvania ; and it is seen that nearly all of them have in reality been taken from one small portion, although they have been supposed to indicate the age of beds many thousands of feet above or below. It is also seen that the geological structure is not so extremely simple as it was formerly supposed to be ; and that no set of straight parallel faults could have diminished to the desired extent the apparent thickness of the series of beds in Eastern Pennsylvania, for the beds curve strongly and extensively in many directions.

It has, however, long been known that, in the midst of the New Red there, an island, so to speak, of ancient Paleozoic rocks occurs. It was never certainly known, to be sure, whether it was really an island in the New Red sea, with New Red beds of equal age north and south of it ; or had later been thrust up through the New Red beds (or remained fixed while the New Red beds on the south sank down), so as to occasion a great disparity in the age of the beds of the two sides. Now it is positively known that there is such a great difference, and that the New Red beds to the south are several thousand feet higher in the series than those on the north. The line of the southern edge of the ancient island continues westward as a great fault ; but far from parallel to the strike, and consequently not helping much, if at all, to diminish the great apparent thickness of the New Red. The fault is there the more obvious from a marked difference in the color of the rocks on its two sides.

But at the eastern end of the island of ancient rocks, just in the edge of New Jersey, the circumstances are somewhat different. There the strike of the beds on the northwest and on the southeast is nearly the same ; and, moreover, the beds of both sides are mainly red ; and they are, besides, in general rather soft shales. Consequently, without the proof given by the observations in Pennsylvania, or perhaps by some not yet made in other parts of New Jersey, it would be extremely difficult, if

not wholly impossible, to detect, still more so to prove, the existence of the fault, in spite of its great throw of over fourteen thousand feet.

The accompanying sketch map shows, at least roughly, the prolongation of the fault nine miles northeastward into New Jersey and of equidistant strike curves, a thousand feet apart in level, on the bottom of different sets of Mesozoic shales north and south of the island-like mass of Paleozoic limestone, of Pennsylvania formation No. II, from the positions determined west of the Delaware by the recent survey. It has been possible to make, roughly, the prolongation of the lines without observing any rock exposures in New Jersey; because the topography shows the geological structure very distinctly on the north of the fault, and with some clearness on the south. On the north, the long straight hills and valleys show very plainly that the strike of the rocks continues almost straight northeasterly in the same general course as on the Pennsylvania side of the Delaware, and nearly parallel to the fault, but gradually bending more to the north. South of the fault the strike as shown by the topography, though not very far from parallel to the fault, is evidently decidedly less straight in the western edge of New Jersey, as it is also in Pennsylvania; but farther east becomes for a space straighter and more closely parallel to the fault and to the northern strike. This structure of the southern shales is confirmed by the topography outside the limits of the map.

The shales on the north of the limestone and fault belong to the same set of beds, mostly soft shales as those near Norristown, and near Yardleyville; while those next south of the limestone and fault are of the set of likewise red, mostly soft shales that is seen near Pottstown, overlying the couple of thousand feet of generally harder and in good part greenish shales of the Perkasio tunnel and its neighborhood, that themselves rest on the red shales of Lansdale. The trap masses given are copied from the New Jersey State geological map, except that the limits of solid trap in place have been conjecturally restricted, according to our experience in Pennsylvania, to only a portion of the whole space covered by blocks of trap and its decomposed earth.

It is very interesting to see how clearly the mere topography shows the geological structure, and so in conjunction with the ascertained relations of the beds north and south of the limestone, makes the presence of the great fault in New Jersey to be known with certainty, in spite of its otherwise thorough concealment through the similarity of the northern and southern shales and of their strikes. The topography, indeed, gives good indication of the geological structure far beyond the limits of the little map, and would perhaps do so through all the New Jersey portion of the older Mesozoic, in spite of the less pronounced variation in character of its beds as regards hardness than what we find among Paleozoic rocks. Now that the older Mesozoic series of beds has been so fully worked out in Eastern Pennsylvania, with several subdivisions of such different color and texture as to be very noticeable in traversing country

SKETCH MAP
 OF PART OF THE
 GREAT FAULT
 IN THE
 NEW JERSEY MESOZOIC,
 BY
 BENJAMIN SMITH LYMAN,
 SEPT., 1893.



THE TOPOGRAPHY IS FROM THE MAPS OF THE NEW JERSEY AND U. S. GEOLOGICAL SURVEYS, WITH 20-FT. CONTOUR LINES. THE NATURE OF THE FAULT AND THE EXTENT OF THE TRAP BEES ARE UNKNOWN.

- | | | | |
|----------------|--------------------|------------------|---------------------|
| TRAP RUBBISH. | POYTS TOWN SHALES. | LANSDALE SHALES. | NORRISTOWN SHALES. |
| TRAP IN PLACE. | PERKASIE SHALES. | GWYNEDD SHALES. | PA NO 11 LIMESTONE. |

SCALE:— 2 MILES TO AN INCH, OR 1 : 126 720.

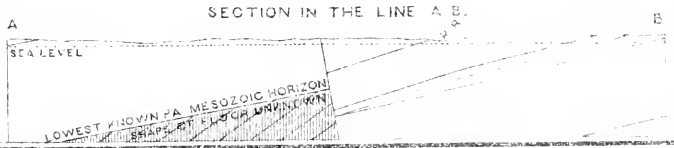

roads, it seems hardly too much to hope that the details of the New Jersey field with its extremely useful topographical map could be very rapidly determined. Without the previous Pennsylvania work, the same result would require much labor and time; and even with the Pennsylvania results at hand, the lack of a good topographical map would occasion great delay and difficulty in working out the details. Such, for example, would be the case in the portion of the Pennsylvania Mesozoic field southwestward from the one already mapped. This matter, among many others, gives New Jersey good reason to rejoice in its topographical map as a means of saving great outlays; while Pennsylvania cannot but find frequent cause to regret its own penny-wise and pound-foolish economy in neglecting so long to make a thorough topographical survey of its whole territory. That neglect is all the more surprising in a State that might well be called the home of American topography as an aid to geology.

NOTE.—Through a misunderstanding of instructions the lithographer has in the cross-section extended the trap rubbish all along the trap bed, instead of confining it to the surface of the ground.

On the genus Tomiopsis.

By E. D. Cope.

(Read before the American Philosophical Society, November 3, 1893.)

TOMIOPSIS gen. nov. Tooth consisting of a much flattened cylinder of hard dentine, which is enclosed in cementum. The latter forms a layer of medium thickness on the external side, and a very thick layer on the internal side, which does not extend below the middle of the length. Crown compressed, tapering gradually to the root, the external face separated from the convex interior face by an angle. Pulp-cavity large, extending to near the cutting face, but occupied near the middle (? normally) by a mass of dentine, which substance also forms the centre of the cutting face, which is thus concave on wear.

The general characters of this tooth are those of mammal of the order Bruta (Edentata). It resembles no known form of the order, but might be said to be intermediate between those of an armadillo and a sloth. It, however, differs from both and from members of the order generally in the gradual anteroposterior contraction of the crown to the root (which is broken off). This circumstance, together with the hollowness of the crown, shows that it is not adapted for continuous service during the life of the animal, but is probably a member of a dentition consisting of more than one series. In this respect it resembles the incisor tooth of some

fishes, but it differs from all of these in the long crown without distinction of root, and in the thick cement investment.

Char. specif. Crown elongate, curved transversely to the long diameter of the grinding face. The latter is a little narrower than a semicircle, and the internal half of it consists of cementum. The dentinal plates form two cutting edges which are separated by a shallow valley of soft dentine. The two edges of dense dentine are in contact at one end of the grinding face, but leave an interval at the other, and both extremities of the external and shorter ridge are folded inwards, forming two loops. External face flat and smooth. Other surfaces also smooth. Length of tooth minus root, on external curve, 14 mm.; long diameter of grinding surface, 7 mm.; short do., 4 mm.; long diameter at broken base, 4 mm. I propose for the name of this species, *Tomioopsis ferruginatus*.

This animal left its remains in a bed of probably Neocene age, which is exposed on the Lapara creek in Western Texas. It was associated with scales of *Lepidosteus*, and bones of *Trionyx* and a tooth of a crocodile, which do not furnish an exact clue to the age of the formation. The specimens were obtained by Dr. E. T. Dumble, Director of the Geological Survey of Texas, and submitted to me for determination.

The Conservation of Osmazome in Roasting.

By Mr. R. Meade Bache.

(Read before the American Philosophical Society, November 17, 1893.)

Time was, and not so very long ago, when I should have hesitated about touching in this hall upon any subject related to cookery, despite the fact that we are by the Constitution of our Society devoted to the promotion of useful knowledge. But now, when the art of cooking seems to be beginning to receive some general recognition in this country, and is rising in some small measure to the dignity of a science, through expert articles in magazines and through departments of special schools, I need no longer fear that even here gastronomical discussion allied to dietetic good might fall upon unwilling ears.

In the days when I was a mighty hunter before the Lord, before I ceased to take satisfaction in killing for pleasure, when I shot deer on the mountain side, once at a safe distance at a retreating grizzly bear, and on another even followed a she one and two cubs towards their lair, without finding it, to which gracious dispensation I doubtless owe the honor of addressing this meeting of the Society, I made a casual observation in the pure air of the mountains whenever I came to cook an evening meal of venison. This was, of the exceedingly large development of osmazome on the roast. Reflection I did not at that time make on the subject. The

simple fact was then observed unreflectingly, to be later collated with other observed facts, from which in sum I drew the conclusion to which this paper points. Intermediately I learned (chiefly through Brillat Savarin's famous work on the physiology of taste) of the great gustatory value of osmazome as a culinary product, but without reference to its dietetic value. This, perhaps, it was that prompted me mentally to revert to my former mountain experiences, when I had seen osmazome developed to the highest degree of excellence that I have ever met, and thereupon other facts connected with the roasting and baking of meat fell into line, leading to the conclusion to which I have referred.

These facts resolved themselves finally into two coördinated ones, open to the observation of any one who has lived in a time which combined roasting meat with the Dutch-oven (sometimes called the tin-kitchen) and baking it in the ordinary household oven. We may observe in the three methods of cooking mentioned, that in the open air, that in the Dutch-oven, and that in the ordinary oven, two steps of degradation. What, then, makes the difference in their products, when the substances submitted to the heat, being essentially the same, can possess no difference in heat-ray selective capacity? It seems to me, obviously, to be caused by the diminution, in two of these processes, of the presence of pure air; that is to say, the deficiency of oxygen, with sufficient aqueous vapor, in association with these processes. Oxygen seems to me, for two reasons, to be the prime factor in the best effect, because that effect seems analogous to other effects in the presence of oxygen, and because nitrogen is recognized as a very inert gas. I do not believe that the effect would be produced at all in a vacuum. Stated in final terms, the perfect development of osmazome in roasting depends, in my view, upon the roast's being immersed in a copious and ever-changing bath of pure air, causing what may be termed oxygenation of the meat.

With the Dutch-oven, the air bath is copious and changing, but it is derived from the kitchen, full of effete matter in suspension, and in a measure deoxygenated by breathing, and sometimes by artificial lights. With the ordinary oven, the same objectionable conditions, in lesser degree, attend the process of baking meat, but their diminution is more than compensated by the circumstance that all the waste products are for the most part confined within the narrow limits of the oven, and the juices of the meat evaporate, on account of the lack of moisture in the deficiency of aqueous vapor in the air. Hence we have, to take the extreme case, the average farm meat-product of the oven, with the osmazome of the exterior utterly destroyed in a black crisp, and even with the Dutch-oven, unless with ceaseless basting, a product far inferior to that of the Homeric method.

I need not pause to descant upon the value of osmazome as a constituent of meat, to be developed, not to be destroyed or impaired by the process of cooking. You are all aware that it consists of various principles, found sometimes even in vegetable substance, combined with empyreumatic pro-

ducts, and is, in sum, most succulent and wholesome for the gourmet, besides being excellent dietetically for the sick and convalescent.

Having had, through my particular course of life, an exceptionally good opportunity of seeing the average mode of cooking in the land, I can say without hesitation that I do not upon reflection consider my conviction at all exaggerated, when I state that its general cooking of meat, as being innutritious and wasteful, is barbarous, and for this reason I once be-thought me of making a small contribution to the sum of knowledge of better things. With the conviction of which I speak in my mind, I thought, a few years ago, in 1887, to aid in the improvement of the art of cooking, at least among the well educated, whence the knowledge might spread, by devising an oven which should approximate in its function to the task of yielding the osmazome which a given piece of meat is capable of producing, in nearly the most perfect form of which the piece is susceptible. We must remember that we do not create osmazome by any process, and that its manifestation on the outer layers of meat subjected to the roasting or baking process does not represent all the osmazome in the piece, but merely that portion which has submitted to what Savarin aptly calls caramelization. Nevertheless, the proper caramelization on a piece of roasted meat is the outward sign of an inward grace. If the piece has been countrified, the outer layers are charred and the interior dried by long continued evaporation of the juices of the meat. If the piece is represented by the opposite extreme of treatment, the outside has never been allowed to become so hardened as to present a serious barrier to the penetration of heat to the interior; the outside is sapid, though crisp, and the interior shaded off from the outside by insensible gradations of rareness: the flavor of the whole surviving in the so-called juice, containing the active principles, osmazome and other extractives, that give delicious flavor. But the ordinary oven is not an instrument capable of effecting this result to a high degree; no existing oven is. Well adapted as the oven is to the drying of dough incidentally to the baking of bread, cake and pies, it is for that very reason, besides others, the poorest possible instrument in its present form wherewith to attempt to imitate a roast.

I fully realized that the course of cookery could not be turned backward in a land where the frying-pan still wields the sceptre against the invasion of the gridiron. I accordingly applied for a patent for an oven which depends upon the simple device of allowing a controllable stream of air, as pure as procurable, to pass through it while the process of cooking is proceeding. For the first time, however, in applying for a patent, I failed to obtain one. The objection made to my device by the patent examiner to whom it was, in the course of routine, submitted, was that it had been anticipated by some one who had invented a wire-gauze door for an oven. I have not, however, changed my opinion that the device does not conflict in the slightest degree with the other invention cited as preventing its acceptance. There are examiners and examiners, and some are not infallible, as I found out many years ago, when, having incidentally used, as a

detail to the production of a new thing, an article that happened to be in the market, an examiner decided against allowing a patent, upon the ground that the man who had invented the incidentally used article had invented it for all the possible uses to which it might in the future be applied; an untenable proposition, easily disposed of upon appeal, by an argument that I made, supported, as witnesses, by Prof. Joseph Henry, Dr. Henry Morton, Mr. J. E. Hilgard, and General Meade.

The validity of patentable invention depends upon two factors, the realization of an idea as embodied in an original apparatus. Thousands of men since Dædalus have conceived of the practicability in various manners of aerial navigation under the open skies, but the embodiment of the idea still remains undemonstrated. The person who invented the gauze-wire door for an oven certainly thereby made a step in advance towards culinary aëration of the oven for meat, and therefore a step in the right direction towards the oxygenation of it, whatever may have been his intention with reference to the result observable. But, even conceding his full intention in that regard, and the incontestability of the result, the apparatus is still a most imperfect one for securing the desirable end, so remote from anything but embryonic function, that it may justly be regarded as simply tentative in the right direction. When, moreover, we additionally consider that patents issue under the characterization of "improvements" in some designated category, containing thereby the implication that there can be no absolutely new invention, it is impossible to see why the apparatus which I submitted to the Patent Office of the United States does not at least come under the designation of an improvement on the gauze-wire door oven, of which my patent agents knew before they entered my application for a ventilated oven (the records always being consulted previously), and therefore could not have thought barred my claim.

If we are to concede that exposing the interior of an oven more or less to circumambient air, of whatever quality, and dependent for its movement solely upon radiation, then any one who ever purposely left an oven door ajar while meat was cooking in it, made to the wire-gauze door an approximate invention. Everything leaks to air and water. If the adoption of either method constitutes oxygenation of an interior, in the sense in which it is here used, then it follows that every natural and artificial cavity on earth can be deemed aërated, even the receiver of an air-pump, except one where there is no untraversed space in the cylinder, secured by surrounding the piston by mercury, as in the air-pump of Kravogl. Aërated and oxygenated, in a certain narrow sense, the oven with the gauze-wire door may certainly be considered to be, but in the true sense, which I had in view in my device, it cannot be considered effective. Such an oven receives from the kitchen all the effete products floating in the air. Its change of air, such as it is in amount, whatever it may be in quality, is only owing to the erratic flux and reflux primarily set up by radiation from the mouth of the oven. On the contrary, the device which I presented for the purpose defined admits the purest outdoor air at com-

mand, the flow of which is compelled to pass continuously around the meat in process of cooking, perfectly controlled by a simple and a single damper, the waste products being liberated into the chimney.

I will anticipate being ask why, if this be so, I have not prosecuted my claim by renewal of it. I reply that it is my intention to take that course when I have time. I still hope to give the first examiner, if he has survived the precariousness of office, or if not, his successor, an opportunity of enlightenment through further demonstration, and of change of mind as to the possibility of a claim to the invention of an oven, characterized by

FIG. 1.

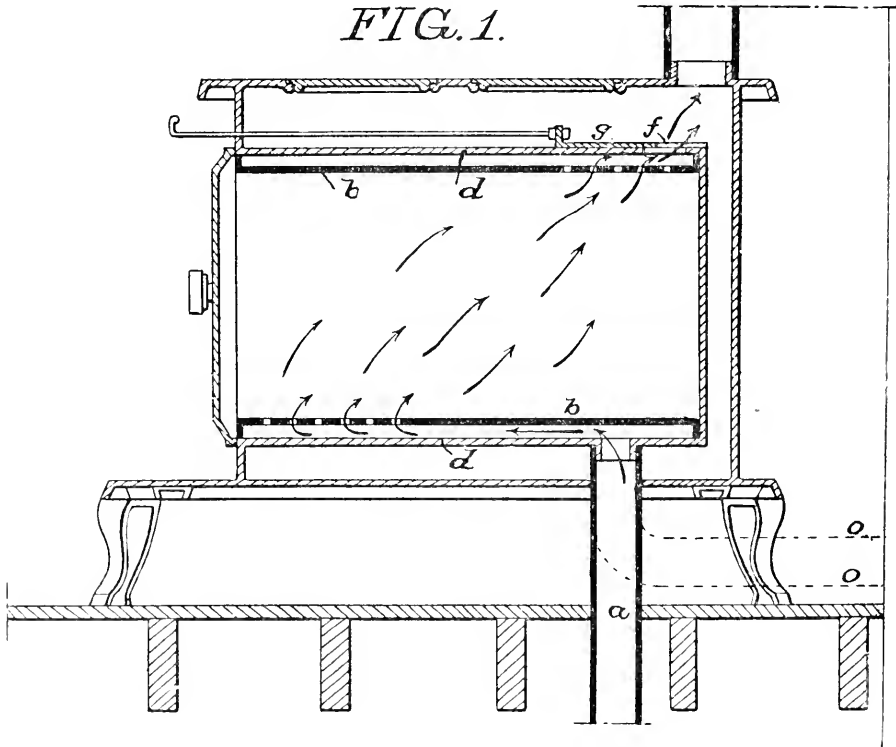

the purity and the regular flow of its air, being invalidated by the previous invention of an oven with a gauze-wire door. If an examiner, whoever he may be, is not open to conviction on a point, then the appeal of a case to the Board of Examiners of the Patent Office is always open to the applicant.

The two diagrams on the blackboard represent the very simple device by which the object that I proposed to myself can be accomplished.

Figure 1 represents a longitudinal section of a modified cooking stove, illustrating the device.

A pipe (*a*) is carried down from the oven of a modified cooking stove, through the floor, and into the cellar beneath the room in which the stove is situated; or where, because of the impurity of the air of the cellar, this plan is not available, the pipe (*a*) may be deflected, as shown by the dotted lines (*o*), and led to the open air through the walls of the room, or in any other convenient manner. In order that the air may be properly diffused and caused to circulate effectively, flanged plates (*b*) are fastened at top and bottom of the oven, between each of which plates and the oven-casing is enclosed a chamber (*d*). The bottom plate, it will be observed, is perforated at and near the front of the oven, and the top plate perforated at and near the rear, and in the top of the oven-casing (*f*) a discharge opening is formed, communicating with the chimney flue, the effective area of this opening being governed by means of the common form of sliding damper (*g*).

It will be seen that thus the volume of cool, pure air, entering the lower chamber (*d*), passes thence to the front, and then escapes into the oven through the perforations of the lower (*b*) plate, there taking the course of diffusion indicated by the direction of the arrows, until it finally escapes from the oven through the perforations in the upper (*b*) plate. It is evident that the perforations in the two plates may be so located as to compel the air to take any course desired through the oven.

It will be observed that, although the flow of air is, for convenience, represented by the diagram as taking place within a somewhat determinate line, yet that, in point of fact, the air entering the oven will, on account of its immediate and great increase of volume, expand into every part of the oven, and its consequent flow towards the upper vent will be from all lateral and inferior directions.

Figure 2 represents a modification of the device illustrated in Figure 1.

In this case the bottom plate of a cooking-range oven is cast, technically "dished," with a depression (*h*) near the front end. Both dish and opening are covered by perforated plates (*b'*). The dish (*h*) has a neck (*h'*), to which is adapted a fresh-air supply-pipe (*a*), and in the upper flue of the range is located a hinged damper (*g'*), turned from the outside by a crank handle, by which the flow of air from the oven into the chimney-flue through the upper perforated plate may be governed.

If it be sought to approach or to rival the excellence of roasting, through the instrumentality of a ventilated oven, five conditions must be fulfilled. The air supplied to the oven must be pure, plentiful, continuous, well-distributed, and regulatable.

The movement of all air, whether free on the surface of the earth, confined in houses, or occupying lesser space, being dependent upon differences of density in different parts, and these differences of density being in turn dependent upon differences in the relative temperature of those parts, purity of air for a ventilated oven may be secured with all the other conditions as concomitants.

The source of supply may be through a conduit from the open air, or through one leading from a properly cemented and sanitarily kept cellar, the terminal of the conduit in either place being covered with metallic gauze to exclude dust. The air of a dwelling-house cellar should be as pure as that of the rest of the house. Hence it is a mistake in a furnace-heated house to draw for the air-chamber of the furnace, directly from outdoors, most of its supply. In a cellar properly regulated in every particular, the air from the furnace should be drawn from outdoors, mostly, if not entirely, through the intermediation of the cellar, thus searching and keeping sanitarily sweet its inmost recesses.

FIG. 2.

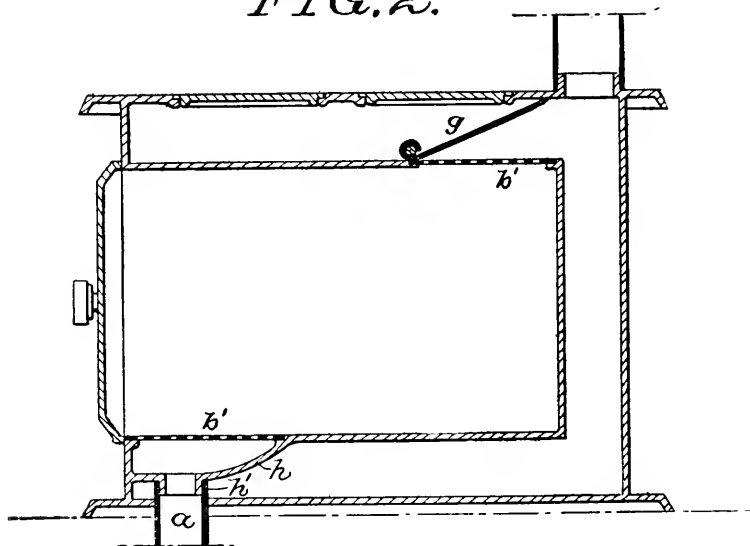

Rapidity of movement of the air for the oven, dependent upon differences of density, being secured by constituting either outdoors or the cellar the source of supply, ample amount of it is thereby necessarily involved. The ability to secure purity for this air being naturally associated with the means adopted to obtain ample movement, involving amount, it remains only to remark that continuity of the movement of the air is necessarily a concomitant of the other conditions, and to consider lastly the points of its regulation and distribution. The first of these ends is secured by the construction of the apparatus described, and the second by the employment of the single damper, as represented in the diagrams exhibited.

Whether the air, after having passed through the oven, shall be dis-

charged outdoors or into the chimney may be determined by household construction. That it should not be allowed to carry its effluvia into the kitchen is certain. Owing to the position in which cooking ranges are usually placed, it would, as a general rule, be most convenient for the air to find its way into a flue to the chimney. But its finding exit there has no especial advantage, physically speaking, over the other mode of exit, for the movement of air at any season of the year, dependent upon the differences of density between the air outdoors and that in the oven, would always afford superabundant volume, to be regulated by the damper, without adding to its updraught the great radiation up the chimney.

I have heretofore confined myself, as in duty bound, to the elucidation of the theme represented by the title of my paper. But it should not be inferred from my omitting discussion of anything beyond it, that I limit the good effect of the presence of ample oxygen in cooking to the preparation of meat for the table. On the contrary, I believe, as the result of observation, not experiment, that some vegetables, and therefore, I conclude, all, are so affected, and cook better in free air than elsewhere. In a qualified sense observation, however, is experiment, where work is done to the hand of one who has not opportunity to do it for himself, but seizes it in observing effects casually offered by that of others, and then combines the facts in conclusions.

A Vocabulary of the Nanticoke Dialect.

By Daniel G. Brinton, M. D.

(*Read before the American Philosophical Society, Nov. 3, 1893.*)

Among the valuable MSS. in the library of the American Philosophical Society is one, now a little over one hundred years old, which contains the only known vocabulary of any length of the Nanticoke dialect or language, once spoken in Maryland, on what is called the "Eastern shore," the region between Chesapeake bay and the Atlantic. Several requests have reached me from time to time to prepare this vocabulary for publication, and it seems to be a duty which the Society owes the republic of letters to make it available for purposes of study and comparison.

The vocabulary was collected at the request of a former President of this Society and of our country, Mr. Thomas Jefferson, by Mr. William Vans Murray, from an old woman called Mrs.

Mulberry, said to be the widow of the last chief of the Nanticokes. She at that time resided at Locust Neck town, Goose creek, Choctank river, Dorchester county, Maryland. The circumstances connected with obtaining the vocabulary are recounted in a letter from Mr. Murray to Mr. Jefferson, which is as follows :

LETTER FROM MR. MURRAY TO MR. JEFFERSON.

Dear Sir:—The enclosed little attempt to make a vocabulary of the language of the *Nanticokes*, may remind you of a circumstance, and promise of mine, which probably have escaped your memory. You gave me the printed list of words last spring. On the reverse of the printed side which is filled up, is added a number of words which occurred to me. The tribe has dwindled almost into extinction. It is still, however, possessed of five thousand acres of land which were reserved to them by the Assembly of Maryland in the first settlement of the Province. The little town where they live consists but of four genuine old wigwams, thatched over with the bark of the Cedar—very old—and two framed houses—in one of which lives the queen, Mrs. Mulberry, relict of the Colonel who was the last Chief. They are not more than nine in number: The others of the tribe, which in this century was at least Five hundred in number, having died or removed towards the Frontiers, generally to the Six nations—perhaps by a comparison of the languages of them and of those a correspondence may be discovered. They went to the Senecas often—you will find they have no word for the personals *he* and *she*. They were much at a loss for all terms to express abstract ideas. It is a little surprising they had a word for *Truth*. They speak their language exclusively among themselves. A few years must totally extinguish the remains of this Tribe and it will be owing to you, Sir, if a trace is left of their language.

I have preferred the very list which I filled in a Wigwam to any neater copy—and therefore have chosen that to transmit to you.

I have the honour to be
Dear Sir with great
respect and attachment

yr. mo. obt.,
W. V. MURRAY.

CAMBRIDGE DORSET, E. S. MARYLAND,
18 September, 1792.

THE HONBLE MR. JEFFERSON.

Mr. Albert Gallatin has made use of this vocabulary in his *Synopsis of the Indian Tribes of the United States*, and from time to time others have borrowed from it; but no effort has been made to publish it in full.

The Nanticokes are first mentioned by Captain John Smith, who encountered them in 1608. Their subsequent history does not offer much of interest. I have traced it in sufficient detail in my publication, *The Lenâpé and their Legends*, pp. 22-25 (Philadelphia, 1885).

A note to the vocabulary states that their last "King," "the famous Wyniaco," died about seventy-five or eighty years before (about 1712-15), and that "his body was preserved and very formally kept in a Awacason-house (Chio-ca-son house), seventy years dead," which means, I presume, for seventy years after his death. The preservation of the bones of their dead was a characteristic trait in the religion of the Nanticokes.

In publishing the vocabulary, I have thought it of interest to add comparative words from other dialects of the Algonkin stock, to illustrate how thoroughly the Nanticoke belonged to it. With a few exceptions, every word collected by Mr. Murray is seen to be a slightly varied form of some expression in Lenâpé or other adjacent dialect. The exceptions would probably fall into the same category were the analysis prosecuted further.

I have also thought it desirable to arrange the words in alphabetical order, for convenience of reference.

The exclamation point, !, so frequently introduced by Mr. Murray, he explains to signify a peculiar, forcible, explosive enunciation of the syllable.

At the close of the vocabulary, the writer adds the following proper names:

We ning go mi usk, the personal name of Mrs. Mulberry, "Mulberry woman" (see below, *Mulberry tree*).

Ama namp quun, the name of the Indian town of Locust neck.

Matt appenen, the name of the Nanticoke Indian town.

VOCABULARY OF THE NANTICOKE DIALECT.

Abbreviations — Len., Lenâpé; N. J., New Jersey Delawares; N. Eng., New England Indians; Chip., Chipeway; Pot., Potomacs; H., Hecke-welder's Nanticoke Vocab.; Sh., Shawnee.

Air, <i>ayewash</i> ; comp. wind, <i>ewesh</i> ;	Ash, <i>pa-w-kawque</i> ; Sh. <i>mea-lawckuo</i> .
Len. <i>geschen</i> .	Autumn, <i>wee-saw-panu</i> (= <i>wee-sapanu</i> , little or short light)
Arm, <i>nickpitq</i> ; Len. <i>w'nachk</i> .	Axe, <i>tummehek</i> ; Pot. <i>tomahack</i> ;
Arrows, <i>allontz</i> ; Len. <i>alluns</i> .	N. J. <i>tomahickan</i> .
Arrowhead, <i>ik-ke-hek</i> (see "Spear").	

- Back, *daduck-quack* ; N. J. *huckun*.
 Back-creek, *pomamato*.
 Back-woods, *ah payw-wagh*.
 Bad, *mattitt* ; Len. *medhik*.
 Banks, *lemouck-coi-um*.
 Basket, *munnole* ; N. Eng. *munnote*.
 Bear, *weinquipim*.
 Beard, *nee-weeghtoniwaah* ; Len. *ni-toncy*, my beard ; N. J. *ni-tuuna*.
 Beaver, *nataque* ; N. J. *nakuee*, or *tomoque*.
 Beech, *pah!-scanemintz* ; Len. *schawemishsi*, red beech-tree.
 Bees, *amook* ; Len. *amoe*.
 Belly, *nut-ah!* Len. *nachtey* (my).
 Belt, *uckq-shit lark* ; Len. *ochquasu* (belt of wampum).
 To bend, *ne wack-kaw-quin-nimon* ; Chip. *nin wakinan*.
 Berry, *mec-cents* ; Len. *mintschi*.
 Bed, *dapp-in*.
 Bird, *piss-seequcs* ; Chip. *binessi*.
 Bitter, *wee-suck un*.
 Black, *oaskag-u* ; *uschkeju* II ; Len. *sucken*.
 Blackberry, *munk-qui-suck* ; Len. *min*, berry ; *sucken*, black.
 Blackbird, *husquinoek*.
 Blood, *puck-cuchque* ; N. J. *mo-hoock*.
 Blue, *puh-squai-loau* ; Cree *sipik-kwaw* ; N. Eng. *peshaui*.
 Body, *no-waw-auh* ; N. J. *uatu-huape*.
 Bone, *whis-scan* ; Len. *wochgan* ; N. J. *okuaan*.
 Bone-house, *man-to-kump* (house to put the bones of the dead into). Probably "sacred place," from Len. *manito*, god, sacred.
 A bow, *kullah'ow*.
 Boy, *wahocki-a-wauntit* ; N. J. *penaetit*.
 Brave, *matt whee-saw-so* (= not cowardly).
 Bread, *app'ow* ; Len. *u'dapponhe*, I make bread ; N. J. *apoon*.
 To break, *ne poick-shitt-own* ; Len. *poquihillen*, it is broken ; N. Eng. *pokeshattouwin*.
 Broad, *manckupah-sai u* ; Len. *amaugi*, large.
 Brother, *ne-ee mat* ; Len. *ni'mat*, my brother.
 Bubby, *noo-naque*, *i. e.*, the mamma ; Len. *uwanagan* (my).
 Buck, *i-e-ape* ; Len. *ajapen*.
 Butterfly, *aumau-co hunt* ; N. J. *amookas*.
 Cedar, *weensquaaquah*.
 Channel, *an-da-timp*.
 Chesnut-tree, *ch! qua-mintz*.
 Chin, *unt-tampquet* ; Chip. *o'dami-kan* (his).
 Child, *awauntet* ; Len. *w'unit* (his).
 Cloud, *matchkatquot* ; *ichemockqh* II ; Len. *machtaquoll* ; N. J. *kumhaak*.
 Cold, *tagh!quior* ; Len. *t'heu* ; N. J. *tua*.
 Cowardly, *wee saw-so ak* (see "Brave").
 Crab, *tah!quah* ; Len. *schaha-muis*.
 Crane, *ah!secque*.
 Creek, *pauptuckquaskque* (see "River").
 Crow, *kuh!-hos* ; Len. *ahus*.
 Cry, to, *num-moan* ; Len. *ganschalamuim*.
 Dance, to, *zdocumb*.
 Day, a, *nuwtocquon* ; *kisucku* II ; Len. *gischgu*.
 Day-break, *waupancy* ; *keesequo*, II ; Len. *gisch-apan*.
 Darkness, *samp-oo-somow* (radical, *pōs* ; = Len. *pis-gu*, it is dark).
 Daughter, *hun taen* ; Len. *w'tàn* (his) ; N. J. *duan-us*.

- Dead, place for the, *mutz-uck-zumpq* (the place where the dead are deposited).
- Death, *ungue-lack*; H. *eweeshawaak ungel*; Len. *chángelükjik*, they are dead; N. J. *nongil*.
- Deep, *timmoh*; Chip. *dimi*.
- Deer, *attque, youcat* (four legs); Len. *achtú*; N. J. *uatu*.
- Devil, *matt-ann-tote*; Len. *nachtando*.
- Dew, *quesuppost*; N. J. *sussuskui*.
- Distance, *wah'soc et*.
- Doe, *noose-at-q*; Len. *nunsch-etto*.
- Dog, *al'um*, H.; Len. *allum*.
- Dog wood, *ah'lauchunnimints*; Len. *hattucano munschi*.
- Dove, *weetuh-tomps*; Sh. *po-weatha*.
- Drink, to, *minnik*; Len. *mene*.
- Dry, *kow-kitt-ow-a*.
- Duck, *quah!quamps* (imitative?); N. J. *quing-quing*.
- Eagle, *ah'whap-pawn top*.
- Ear, *nuch-tow-huck* (my); Len. *w'ittuwak* (his); N. J. *nitruk*.
- Earth, *ahkee*; Len. *hacki*; N. J. *haukke*.
- Eat, to, *meetsce*; Len. *mizu*, he eats; N. J. *miitshe*.
- Eel, *pall'in*.
- Egg, *wauwhq* (with a whiff); Len. *wahhcall*, pl.
- Evening, *weaku*; Len. *wulaku*.
- Eye, *nucks-skencequah* (my); Len. *w'uschginquall*, his eyes; N. J. *uiiskingul*.
- Face, *assung-gui*; Len. *w'uschgink*, his face (comp. "Eye"); N. J. *uiisking*.
- Fall, to, *ah-kinnitsish*; Len. *meschiechán*.
- Falsehood, *e-kitt-co*.
- Far, *wachschuit*; Chip. *wassa*.
- Fat, *pim*; Len. *pomi*.
- Father, *nowoze* (my); Len. *w'och*; N. J. *nukuaa*.
- Fear, *quischa-asch*, H.; Len. *wischusi*.
- Finger, *na-mishah!qu-ulganz*.
- Fire, *tunt*; Len. *tindey*; N. J. *tuande*.
- Fish, *wammass*; Len. *namees*.
- Fly, a, *pootzah*; Len. *utsche*; N. J. *sa-kiime*.
- Fog, *howewen*; *awwan*, H.; Len. *awan*; N. J. *anan*.
- Food, *mettsah* (comp. "Eat, to").
- Foolish, *cuip-shee-in quo*; Len. *gubtocha*; N. J. *kipitsheote*.
- Foot, *nist* (my); Len. *uchsit*.
- Fox, *wauks*; Len. *woacus*.
- Frog, *clacqu-iss*; Cree *ayekis*.
- Frost, *togh!poh!* Len. *topan*; N. J. *tuupan*; N. Eng. *taquattin*.
- Girl, *pukquah*; Len. *ochquetsch*.
- God, *mann!-itt*; Len. *manitto*.
- Good, *wec-ee*; *watti-e u*; Len. *wulit*.
- Grass, *mass-que-quise*; Len. *masgik*; N. J. *muskiikal*.
- Grave, *wawskouko*; Len. *pokawen*, a hole.
- Green, *ah'skaah-tuck-qui-a*; Len. *asken*.
- Gum, *pook-sacq-in-ment*.
- Guts, *walah-kiss-sisk*.
- Hail, *ah'sinlipro* (*assin*, stone); N. J. *sidonitla*.
- Hair, *nee-eesquat*; Cree *w'estakaya*.
- Hand, *nut untz*; N. J. *nacking*.
- Hard, *mois-kai u*; Chip. *mashkawissin*, it is hard.
- Hare, a, *timihawque*.
- Hate, to, *ne man-nin-now*.
- Hawk, *mah'squallen*.
- Head, *uelahammon*; Len. *w'il*, his head; N. J. *wheel*.

- Hear, to, *no-oun-tum*; N. J. *ni-in-dum*.
- Heart, *wea'scheu*, II. (his); Len. *w'dce*.
- Heat, *nip(ow)kiss*, from Alg. *nibin*, summer.
- Hickory-tree, *psee-cun*.
- High, *whu-sa-nee-p-ai-u*; *schpum-mend*, II.; Chip. *ischpumagad*, it is high.
- Hill, *lemuckquickse*; Len. *welemuck-queck*.
- Hot, *app et-tuwr!* Cree *abweeyaw*.
- House, *youch-huck*; *iahach*, II.; Len. *wik*; Pot. *ye hawkins*.
- Husband, *nups-soh'soh!* (my).
- I, *nee*; Len. *ni*.
- Ice, *hah'laggu-quitz*; Len. *m'hoc-quami*; N. J. *hukkooen*.
- Joy, *ne-moo ye-ow-wass*.
- Jump, to, *ni-s poiecksh*, I jump; Len. *ni-pouktsch*.
- Kill, to, *nepoieckt-tow*; Alg. root, *nipa*.
- King, *tall'ak*; N. J. *qualis*, master, from Len. *alokakasın*, to have power over another, from *allowat*, strong.
- Large, *mang-ai-u*; Len. *amangi*.
- Laugh, to, *wci aih-e mitt-a-ha*; Len. *wchemooluk*, he laughs.
- Lean, *moosor wak*; Chip. *asowa*.
- Leg, *muck-cat*; Len. *w'ickaut* (his).
- Lie down, to, *cow-si-nee*.
- Life, *ne quee quawack*; Pot. *kekugh*.
- Light, *wassaguitayw*; Len. *waché-jen*.
- Lightning, *ton-que-ah*.
- Lip, *nussihecque*.
- Lizzard, *oh!-kaush-kiss*; Len. *gégáchxiis*.
- Locust-tree, *klu-one-nahq*.
- Long, *quah!nah!! qut*; Len. *guna, quounagen*.
- Love, to, *w'rummoi*; *quummosch*, II.; N. Eng. *cowanmaunsch*, I love you.
- Low, *tah'quah'quah!-su*; Len. *tachpachs*.
- Maize, *cart-na-woop*.
- Man, *wohacki*; *uwap*, II; Len. *lennāpe*.
- Maple tree, *waw-see-ke-me*; Len. *schiechikiminsi*.
- Marsh, *nah'squuh!* Len. *masgeku-wici*.
- Mocking-bird, *ahmittongha*.
- Mat, a, *yawsky*.
- Meat, *pumantah* (hog's meat).
- Milk, *noo-oo-wack*.
- Mole, *alcmob-schkim-nitz*.
- Month, a, *nuquoluc quaquoa*.
- Moon, *atupquonihanque*; Len. *tpocuniwi gischuch* (night sun).
- Morning, *weschpa* II.; from Len. *gischgu*, day.
- Mother, *nieque*; Chip. *ninge*; N. J. *onna*.
- Mountain, *pomat-tinike*; *pemetenackk*, II.; from Alg. root *āmat*, to mount up.
- Mouth, *huntooney*; *mettoon*, II.; Len. *w'toon* (his).
- Mud, *piss-suequa*; Len. *assiscu*.
- Mulberry-tree, *whie-in-guaque*; Len. *mint quaqu*.
- Muskrat, *wak-keh!* Chip. *wachashk*.
- Nails (finger), *nuck-can sump*; Len. *nichgasch*.
- Narrow, *tsipais-u*.
- Near, *pechtschtschu*, II.; Len. *pech-hutsch*.
- Neck, *nissi-kip-puehgh!* N. Eng. *sitchipuck*.
- New, *whuis-kai-u*; N. J. *uiisksu* (young).

- Night, *toopquow*; *tuppucku*; Len. *tpoku*; N. J. *tipaake*.
- No, *mattah*! Len. *matta*.
- Nose, *nick-kee-u* (my); Len. *w'ickiwon* (his); N. J. *uikiiko*.
- Oak, *wee-seek-e-mintz*; Len. *wisach-gak*.
- Old, *kutt-a-nai-u*; Cree *ketteyatisu*, he is old.
- Opossum, *nih'simîn*.
- Owl, *quōo-waant*; Chip. *koko*.
- Oysters, *kaw-sheh*!
- Oyster-shells, *tsee-ko-mack*.
- Partridge, *kittycawndipqua*.
- Peas, *pee wah!sh-quist*.
- Peace, *e-wee-ne-tu*; Chip. *inawen-divin*; N. Eng. *aquène*.
- Pheasant, *uh!quis capitz*.
- Perch, *kosh-kike nesuc*.
- Persimmon-tree, *law wacq* (see "Mints").
- Pigeon, *not siminîsuk*.
- Pine-tree, *qaat*; Len. *cuwe*.
- Point of land, *alla-maa-wampk*.
- Pole-cat, *tzuckquakq*; N. J. *skuwak*.
- Pond, *nippiss* (*nip*, water).
- Poplar-tree, *wee-saa-quack*.
- Pretty, *wee-e-eat*.
- Queen, *tulla!kesk* (see "King").
- Raccoon, *anasup*; Len. *espanni*; N. J. *nahanuan*.
- Rain, *winiow*; *sokelan*, H.; Len. *sokelangetsch*, when it rains; N. J. *suuklan*.
- Rainbow, *quenuck-quenuck*; N. J. *monukooen*.
- Rattlesnake, *eeh!seekq*; Chip. *jishigwe*; N. Eng. *sesak*.
- Raven, *uckquak*.
- Red, *psquai-u*; N. Eng. *msquû*.
- Red-bird, *pishquiss eeps*.
- Religion, *Lapp!-poi o-wees*; probably "a coming together," from Len. *lappi-lenin*.
- River, *pumptuckqual'*; *peemtuck*, H.; Len. *kikhit-tuck*; Chip. *pim*, to flow.
- Rock, *kosheup*; Chip. *kischcab*, a perpendicular rock.
- Kun, to, *un-to-mho-waish*.
- Salt, *tzee-e-oose*; Len. *sîkey*.
- Sand, *loh!-ki*; Len. *lékau*.
- Sea, *mank-nippint*; *kittuhend*, H.; N. J. *kihittuan*.
- See, to, *naa-m-m*; Len. *nemen*; N. J. *nî-naaman*.
- Shark, *witt-ameek*; Len. *ameek*, fish.
- Shallow, *tacq-e-timps oh*.
- Shame, *katt-ak-katts*.
- Shoes, *meckhîsins*; Pot. *mockasins*; C. *maskîsins*.
- Shore, *saumps-a-mu*.
- Sick, *huntoi-miss*; Chip. *nin nani-pinio*, I am sick.
- Side, *pomeetempquat*.
- Sing, to, *nuck-und-oh*; Len. *nachgo-homân*.
- Sister, older, *nimpz*; Chip. *nimisse*.
- Sister, younger, *neighsum*; Chip. *nishime*.
- Sit, to, *qui-ah quup*.
- Skin, *nowas-sium*.
- Sky, *moosecaquit*; Len. *moschhac*; N. J. *musheek*.
- Sleep, to, *n-upp*; Chip. *nipa*.
- Small, *lumaîsu*; *namahchtschu*, H.; Chip. *maskig*.
- Smell, to, *ne quees-sum-un*.
- Smoke, *niponguôt-tai* (I smoke); Chip. *nin pashkinauce*.
- Smoke, to smoke a pipe, *p-simoi*.
- Snake, *ash-quoque*; Len. *achgook*.
- Snakeroot, *pah!scho-hook-quick*; Len. *blëu-hôtik*.
- Snakebite, *ah!sckok-kas sipekoke*.

- Snow, *qūōono*; *gu'no*, H.; Len. *guhū*; N. J. *niūna*.
- Soft, *patt-ah-ki-u*; Len. *w'tācku*; N. J. *taukke*.
- Son, *nucks-quah* (my); Len. *quis-soll* (his).
- Sorry, *dah-qua-a-nee* (I am sorry).
- Sour, *tchee-ee-run*; Len. *schwon*.
- Speak, to, *ne kitt-o-was*; N. J. *gi-kūu*.
- Spear, *ne poikē-hek* (see "Arrow-head").
- Soul, *tsee-e-p*; Len. *tschipey*.
- Spring, the, *see-qui no*; Len. *siquon*; N. J. *sick-quim*.
- Spring, a, *mōō-nip-pque* (nip, water).
- Squirrel, *moock-key*; N. J. *hou-neck*.
- Squirrel, flying, *ah!sappaneques*; ground squirrel, *muck quissah*.
- Stand, to, *dogh-kīnch*; Len. *pach-suequin*.
- Star, *poomolasuque*; Pot. *pumma-hump*.
- Stone, a, *kaucsup* (see "Rock").
- Straight, *lemat-tah'-quot*.
- Strike, to, *ne pack-come*; Len. *po-pachgan-damen*, to strike dead.
- Strong, *miss-ki-u*; Cree *maska-wisū*.
- Summer, *mashaquapan-u*; *mech-schak wapau*, H. (= the great or long light).
- Sun, *ah-quak*; *aquequaque*; *aeque-ckky*, H.; Len. *gischuch*; N. J. *kiisku*.
- Sweet, *wee-ing-on*; Len. *wingun*.
- Sweat, *nip-oo-kiss*.
- There, *emuk*, H.
- Thick, *kee-puck-an*; Len. *cabbach-can*.
- Thigh, *hunts-sunque*.
- Thin, *ah-shee-penz-o*; Len. *w'scháb-hm*.
- This, that, *yon-kan-nah*; Len. *nanni*.
- Thou, *kee*; Len. *ki*.
- Thunder, *wrah!-shuck*; Len. *ped-hakquon*, it thunders; N. J. *patihaakun*.
- Tobacco, *oh'pucque*; N. Eng. *puck*.
- To-day, *ecapawegup*.
- Toe, *nicks-see-equunumps* (my) (= my foot, *iks it*).
- To-morrow, *allappahree*.
- Tongue, *neeannow-ah!* (my); Len. *w'ilano* (his).
- Tooth, *neeput-tumps* (my); Len. *w'ipit* (his); N. J. *nipitil*.
- Tree, *petuicque*; *pauk*, H.; Chip. *pak*.
- Truth, *ko-o-lam*; Len. *leke*, true; *wulam*, true.
- Turkey, *pah!quun*; Len. *bloeu*; N. J. *tschikuuna*.
- Turkey-buzzard, *moh waas*.
- Ugly, *matt-it* (= bad).
- Valley, *qualliquackimuck*; *pech-sechkamikot*, H.; Len. *pachsujeck*.
- Vine, a, *mallaw cominamintz*.
- Viper, *apo-tass-sees-a*.
- Walnut-tree, *ah!sin-ni-mintz* (from *assin*, stone).
- Walk, to, *n-gutt-o-was*.
- War, *matt-ah-kass-on*; Len. *nach-tájeen*.
- Warrior, *matt-ah-ki-ween* (see "War").
- Water, *nip*; Len. *m'bi*; N. J. *bee*; Alg. *nipi*.
- Wet, *kiss-ep pai-u*; Len. *niskpeu*.
- Whistle, to, *ne queezkso-uh quitt-um*; Len. *ni quischktoonheen*.
- White, *waap-pay-u*; Len. *wopasu*; N. J. *opeck*.
- Whore, *amattz-e-no*.
- Wild-cat, *lul'waa!quepuss*; N. Eng. *pussow*.

Wild goose, *quà-hāw-quunt*.
 Winding, *apuas suc-tucqut*.
 Winter, *pooponu*; *iluppoon*, H.; C.
pipon; N. Eng. *popon*.
 Wife, *nee-eeswah!* (lit. "my wo-
 man").
 Wise, *wee-sauce*.
 Woman, *acquahique*; *aquahoag*,
 H.; Len. *ochqueu*.
 Wood, *meeh-shiz*; *michsez*, H.;
 Len. *mīnschī*; Pot. *musses*.

Woods, *pump tuck-koisk*; Len.
tékene; Sh. *teikon*.
 Year, a, *nuquolacutquomai* (see
 "Month").
 Yes, *a-a mch!*
 Yesterday, *holacqueor*.
 Yellow, *wee-sa-way-u*; Len. *wisa-
 weu*.
 You, *kee* (= thou).
 Young, *luimaisu* (see "Small").

1, *nukquit*.
 2, *ni-eez*.
 3, *nis* (*whu*).
 4, *yaguh* (*whu*).
 5, *nup-pai-a*.
 6, *noqūttah*.
 7, *my-yay-wah*.
 8, *tzah*.
 9, *passa-conque*.
 10, *millah!*
 11, *ah!tzickquit*.
 12, *ahiz-naecz*.
 13, *ahiz-whus*.
 14, *ahiz-yough*.
 15, *ahizup-pay-ah*.
 16, *ahizaquutah*.
 17, *ahiz mayaway*.

18, *ahiz-wah*.
 19, *ahiz-passa, conque*.
 20, *nee-es-mittah*.
 21, *neequa-nichquit*.
 30, *su-pooks-kay*.
 40, *yow-pookay*.
 50, *nuppay-e poosquah*.
 60, *nequuttah-e poosquah*.
 70, *may-ah-wa-e poosquah*.
 80, *tzaw-e poosquah*.
 90, *passaconque-e poosquah*.
 100, *weenba kissana*.
 200, *nees kissana*.
 300, *waiswa kissana*.
 400, *you-wah!kissana*.
 500, *nuppaia tashakissana*.
 1000, *nuttah-taska kissana*.

*Second Addition to the Knowledge of the Batrachia and Reptilia of
 Costa Rica.*

By E. D. Cope.

(*Read before the American Philosophical Society, November 17, 1893.*)

The present paper is a second supplement to a memoir on the Batrachia and Reptilia of Costa Rica, published by myself, in the *Journal of the Academy of Natural Sciences of Philadelphia*, for 1875, p. 93. The first supplement is a brief one, and was published in the *Proceedings of the American Philosophical Society*, 1879, p. 271. The whole number of species enumerated up to the latter date was one hundred and thirty-three.

The present supplement is based on material which I have received from my friend, Mr. George K. Cherrie, who is an officer of the Museo

Nacional, of San José. This material differs from that described in former papers in the fact that it was mainly obtained on the Pacific slope of the country,* while the latter was collected on the Atlantic slope and on the central plateau. In the enumeration which follows, the localities are mentioned in greater detail. The total number of species sent by Mr. Cherrie is thirty-three, of which sixteen are additions to the fauna of Costa Rica, and nine are new to science. I hope to be able to figure these species at an early day.

BATRACHIA.

URODELA.

HAPTOGLOSSA PRESSICAUDA, gen. et sp. nov.

Char. gen..—Group of Thoriinae, which includes *Thorius* Cope and *Typhlotriton*† Stejneger; hence the vertebrae are opisthocelous and the carpus and tarsus not ossified. Tongue adherent in front and by the middle. Digits not distinct, 4-5.

This genus is of much interest as the first one discovered in Tropical America in which the tongue is not boletoid in form. It seems also that the relation of this form of the western coast to those of the east coast in this group is the same in Costa Rica as that which prevails in North America. It is well known that no species of salamander, with a boletoid tongue, is found on the Pacific coast of North America.

Char. specif..—Form slender, limbs very small. Length of tail equals that of the body without the head. Length of head contained in that of the body to the vent, seven and a half times; the width less than the length. A gular and nineteen costal folds, the latter not very distinct. Fore and hind limbs each equal to three intercostal spaces. Digits indicated by emarginations of the foot border. Vomerine teeth in two moderately arched transverse series, not produced posteriorly on the middle line, hence well separated from the rather wide single patch of parasphenoid teeth. Tongue rather small, oval. Nostril of moderate size, situated well anteriorly. Eye, large. Tail compressed from near base to apex, with a median dorsal, but no ventral groove, and well-marked vertical grooves.

Color, uniform black; under side of head and tail a little paler than other regions.

Measurements.

	MM.
Total length	62
Length to posterior angle of mouth	4
Length to fore limb	8
Length to hind limb	28.5
Length to base of tail	31.5
Width of head at angle of mouth	3

This species resembles superficially the three small salamanders of

* The only exceptions are Nos. 338, 339, and 347.

† For the place of this genus, see Cope, *Proceeds. Acad. Phila.*, October, 1893.

Mexico and Central America, the *Thorius pennatulus* Cope, and the two species of *Edipina* (*Opheobatrachus*). Besides the generic characters, it differs from the latter in the shorter and compressed tail, etc. From the former it differs in the larger number of costal folds, smaller nostril, and in coloration, etc. The single specimen was found at Palma, and is No. 293 of the collection.

EDIPUS VARIEGATUS Gray. From Buenos Ayres, No. 301.

SALIENTIA.

BUFO MARINUS L. Lagarto, Nos. 342, 345; Buenos Ayres, Nos. 305-312.

BUFO HÆMATITICUS Cope. Buenos Ayres, 310; Rio Grande, 366.

HYLA GABBII Cope. Buenos Ayres, 306, 309; Lagarto, 375.

HYLA NIGRIPES Cope. Buenos Ayres, 311.

LIOHYLA RANOIDES Cope. *Lithodytes ranoides* Cope. *Proceeds. Amer. Philos. Soc.*, 1885, p. 275.

This species differs from the *L. rugulosa* Cope (*Proceeds. Amer. Philos. Soc.*, 1869, p. 160) in its more elongate muzzle and in the smaller and differently shaped tympanic membrane. In the *L. rugulosa* the membranum tympani is round, and is about equal to the eye; while in the *L. ranoides* it is a vertical oval of about half the same diameter. The belly of the *L. ranoides* is free from rugosities.

Three specimens of this species are in the collection, and they are very dissimilar in coloration, and neither of them resembles the type. They may be arranged thus.

- I. Light gray; no dorsal stripe or interocular cross-band. No. 333, near Buenos Ayres.
- II. Dark brown, a light interorbital crossband, and black W-shaped mark on interscapular region. No dorsal stripe. Type from Nicaragua. No. 14,179, U. S. National Museum.
- III. Dark brown, with a pale, narrow dorsal line, and pale interocular cross-band. No. 288, Terraba.
- IV. Dark brown above with a broad pale dorsal stripe, as wide as the internareal space. No interocular cross-band. No. 304, Buenos Ayres.

These specimens agree in having four dark spots on the upper lip, of which the anterior is below the nostril; in the legs being marked with a few dark brown cross-bands; and in the femur being obscurely marbled behind. The vomerine teeth are close together, entirely within the interior border of the internal nares, and much posterior to the latter. In No. 304 the dorsal integument displays a fold from cranium to sacrum on each side of the wide dorsal stripe; on the external side of each of these anteriorly three short folds extend upwards and backwards from the orbit.

No. 288 is a female, and resembles in color the *Lithodytes melanostictus* Cope (*Journal Phila. Acad.*, 1875, p. 109), which is from alpine

Costa Rica. That species, however, has no digital webs, and the tympanic membrane is only half as large, its transverse diameter being only a quarter of that of the eye fissure. The vomerine teeth also are not so close together. Specimen No. 288 is a female, and is distended with eggs. There are no traces of dermal folds. In No. 333 there are traces of the folds. Dr. Boulenger (*Catal. Batr. Sil. Brit. Mus.*, Ed. ii, p. 201) describes a species of *Liohyla* under the name of *Hylodes palmatus*, although he places under it as synonymous the older names of *Ligla* (*Liohyla*) *guentherii* Keferstein and *L. rugulosa* Cope. The size of the tympanum, and length of hind limb are indefinitely described, but the back and sides are said to be tubercular, which is not the case in this species. Mr. Boulenger also states, rather indefinitely, that the toes of his *H. palmatus* are "one-third webbed." The palmation in *L. ranoides* extends to the extremity of the metatarsals. This is one-third the length of the first and second digits, but much less than a third the length of the other digits.

The eggs of this species are of extraordinary size, equaling large peas.

LITHODYTES FLORULENTUS, sp. nov.

In introducing a new species of Central American Lithodytes, it is necessary to point out clearly the distinctive features of those already known. I confine my attention at present to the species with plain frontoparietal bones, and therefore omit further reference to the *L. plicatus*, *L. megacephalus* and *L. gulosus*, where there is a crest along the superolateral angle of the skull. The other species differ as follows:

I. Heel not reaching the muzzle.

- Vomerine patches widely separated; digital dilatations large; colors plain.....*L. diastema* Cope.
 Vomerine patches close together; digital dilatations small; colors variegated.....*L. florulentus* Cope.

II. Heel of extended leg reaching muzzle or beyond.

- a.* Tympanic drum equal half to two-thirds diameter of orbit.
 Digital dilatations small, especially on hand.....*L. rhodopis* Cope.
a. Tympanic drum small, one-fourth diameter of orbit.
 Digital dilatations large, especially on hand.....*L. melanostictus* Cope.

The only specimen of the *L. florulentus* is damaged as to the integument of its head, which has been destroyed by agencies unknown to me. The skull with its muscles, and the rest of the body with the integument, are preserved. The head is short and depressed, and the canthus rostralis is not distinct. The length of the muzzle from the nostril to the orbit is about equal to the antero-posterior diameter of the latter, and the nostril is quite near the end of the nose. The tongue is subround, and is a little wider than long in its present condition. The internal nares are well forwards; and the vomerine teeth are in two fascicles which are close together, and are so far posterior to the nares as to be in transverse line with the pala-

tine ridges. They are also as far as their own diameter within the antero-posterior line of the internal nares. The ostia pharyngea are narrow slits about as long as the nares. The tympanic drum is destroyed, but the space for it is a vertical oval, with about half the anteroposterior diameter of the orbit. The heel of the extended hind limb reaches the anterior border of the orbit. The extremital dilatations are very small. There is a rather large oval internal or prehallucal tubercle which is entirely sessile; there is a small external tubercle. There are two palmar tubercles, and those of the anterior digits are distinct but flat; those of the posterior digits are less distinct. The integuments of the inferior and concealed surfaces are smooth; on that of the back a few small tubercles are present.

The color of the upper surfaces is gray dusted with blackish. The inferior or posterior surface of the hind legs is black, and this color is continuous with dark-gray cross-bands which cross the superior faces of the tibia and femur, four over each. The spaces between these cross-bands are scarlet. The posterior part of the sides and anterior part of the abdomen is blackish to brownish, with crimson and orange spots of various sizes and shapes, the largest in the groin. Three cross-bands on upper side of foot, and three across forearm. Coloration of head unknown.

Measurements.

	MM.
Total length of head and body.....	35
Length of head to posterior line of tympanum	12.5
Width of head at posterior line of tympanum.....	15
Interorbital width.....	3.5
Length of fore limb.....	20
Length of fore foot.....	9
Length of hind limb from groin.....	51
Length of hind foot.....	24
Length of tarsus.....	9

The only specimen of this handsome species contained in the collection is from Boruca, and is No. 327.

LITHODYTES RUODOPIS Cope, *Proceeds. Acad. Phila.*, 1866, p. 323; *Proceeds. Amer. Philos. Soc.*, 1869, p. 160. *Hylodes sallai* Günther, *Proceeds. Zool. Soc.*, London, 1868, 487, Pl. 38, Fig. 3. *Lithodytes podiciferus* Cope, *Journal Acad. Phila.*, 1875, p. 107, Pl. 23, Fig. 9. *L. habenatus* Cope, *l. c.*, p. 109. *L. muricinus* Cope, *l. c.*, p. 108, Pl. 23, Fig. 13.

After full comparison of the material at my disposal, I strongly suspect that all the forms described above as distinct species are simply varieties of a single variable one. In some young individuals the vomerine series of teeth appear more transverse, as in the individual called muricinus. In such small individuals, the pigment is apt to be brilliant. In

the present collection a small specimen of only 13 mm. in length has the entire superior surfaces of a bright violet, as in the specimen called *muricinus*; but it presents no structural difference from the form *habenatus*, and small examples of the form *podiciferus*. From Buenos Ayres; No. 331.

HYLODES STEJNEGERIANUS, sp. nov.

Muzzle flat, canthus rostralis distinct, concave, extremely little prominent. Nostril near the extremity and as far anterior to the eye as the long diameter of the eye slit. This latter dimension equals the diameter of the nearly round tympanic membrane. Integument of head smooth; that of back with a delicate median fold, and a fold on each side which diverges at the scapular region and extends to the orbit. Parallel to the laterodorsal fold is a dorsolateral fold on each side which terminates anteriorly near to the oblique fold just mentioned. Between these folds the integument is tubercular. Sides and belly roughened with small tubercles; breast and throat smooth. Tongue longer than wide, pyriform, scarcely notched. Vomerine teeth in two fascicles well behind the choanae, and farther apart than each one is within the longitudinal line of the internal border of the nares. The heel of the extended hind limb reaches the anterior border of the orbit. Width of head 2 3 times in length of head and body. Digital enlargements small.

Color above a dark bistre brown, with a pink band extending on each side from the eye to the sacrum, passing above the tympanic membrane. Posterior limbs blackish brown, except the inferior side of the femora, which are a lighter brown. Fore limbs pink with brown cross-bands. Belly dirty white, the breast and throat densely dusted with brown. Head uniform blackish brown, with the exception that on the edge of the upper lip there are three pairs of pale vertical bars which represent the borders of three lip-spots.

Measurements.

	MM.
Length of head and body.....	15
Length of head to posterior border of tympana.....	5.5
Width of head at posterior border of tympana.....	5.5
Length of fore limb.....	11
Length of fore foot.....	2.5
Length of hind limb.....	24.5
Length of hind foot.....	11
Length of tarsus.....	4.5

It is only necessary to compare this species with the *H. polyptychus* Cope (*Proceeds. Amer. Philos. Soc.*, 1885, p. 276) from Nicaragua. In this species the top of the head and especially the eyelids are tubercular, while they are smooth in the *H. stejnerianus*, and the integument generally is covered with larger and more numerous warts. The muzzle is shorter

and wider, and the tympanic disc is only two-thirds the eye diameter. Finally, the series of vomerine teeth are more transversely extended.

This species is dedicated to Dr. Leonard Stejneger, the distinguished zoölogist now in charge of the herpetological department of the U. S. National Museum, Washington. It is from Palmar; coll. No. 295.

LEPTODACTYLUS QUADRIVITTATUS, sp. nov.

Form lanceolate; muzzle narrow and prominent, nostril a little nearer the orbit than the extremity of the muzzle, but further from the orbit than the diameter of the latter. Extended hind limb reaching the anterior orbital border with the heel. Interorbital space wider than eyelid. Skin smooth except some warts about the scapular region. Two stout glandular ridges on each side of the vertebral median line. A discoidal abdominal fold. Subdigital tubercles well developed; unguis phalanges not dilated. A distinct oval internal metatarsal tubercle.

The vomerine teeth are in two arched series which extend outwards to the line of the external border of the choanæ, and approach close together on the median line. The choanæ are large and about equal the ostia pharyngea. Tympanic disc a horizontal oval, its long diameter equal two-thirds that of the eye. Tongue a wide longitudinal oval, openly notched behind.

The ground color above and on the sides is gray, which is marked above with four longitudinal black bands. The two median of these are wider and commence at the end of the muzzle, and extend to the extremity of the urostyle. They expand above and over the eyelids. The lateral bands commence narrow at the orbits, and widen on the sides, extending to the groin. The median dorsal band of the ground color is paler than the rest of the ground, and has a pinkish tinge, which is probably more distinct in life, judging from traces of pink near the orbit. The side of the head is black to and including the tympanic disc; excepting a pale stripe which passes below the eye to the lower border of the tympanic disc. It is crossed by two or three black lines which descend from the eye to the black lip. A pale crescent in front of tympanic disc. A pale line extends upwards and forwards from the groin on the side. The limbs are all cross-banded, except the tibia, whose upper surface displays an irregular, wide, longitudinal band, which is a marked peculiarity. Posterior face of femur bounded below by a pale line, which is bordered above by a brown band. Tibia uncolored, foot brown, below.

Measurements.

	MM.
Length of head and body.....	37
Length of head to line of posterior edge of tympana.....	14
Width of head at line of posterior edge of tympana.....	15
Length of anterior limb from axilla.....	18
Length of anterior foot.....	8

Measurements.

	MM.
Length of posterior limb	65
Length of posterior foot.....	31
Length of tarsus.....	12

From Buenos Ayres; No. 365.

This species is allied to the *L. labialis* Cope and the *L. longirostris* Blgr.; the former Mexican, the latter Brazilian. In the latter the dentition and form of head are similar; but the front is narrower than the eyelid, the hind legs are longer (the heel reaching the end of the muzzle), and there are but two dorsal glandular folds. The length of the limbs is as in *L. labialis*, but the series of vomerine teeth are further extended outwards, the muzzle is longer; and the glandular tubercles of the groin of the *L. labialis* are wanting. The original description of the latter species was taken from young individuals, and includes the statement that the species has no discoidal abdominal fold. This is a mistake; the fold is present.

ATELOPUS VARIUS Stannius.

Nos. 296-298, Palmar.

DENDROBATES TINCTORIUS Wagl., subsp. AURATUS Gird.

Nos. 290, 369, 370, 371, from Palmar. No. 339 from Talamanca is similar, but the pale cross-bands both above and below are much wider, much reducing the area of the black ground color.

Subspecies VITTATUS, nova. In this color form the ground is black everywhere, and the only marks are a pale stripe on each side, which passes from above the groin above the extremities of the diapophyses of the vertebrae, on the upper eyelids, and joins its mate on the end of the muzzle. This form has the lateral stripes of the *D. talamanca*, but resembles it in no other respect. The second finger equals or is longer than the first. In *D. talamanca* it is shorter. Nos. 367, 368, from Buenos Ayres.

REPTILIA.

LACERTILIA.

MOCOA CHERRIEI, sp. nov.

This species resembles the *M. assata*, but differs conspicuously in these respects: First, the limbs are relatively considerably more elongate, for when appressed to the side they overlap by the length of the anterior foot. In the *M. assata* they fail to meet by the length of the fore leg. Second, the scales are more numerous, being in thirty-four rows: and those on the sides are smaller than those on the back and belly. In *M. assata* the number of rows does not exceed thirty, and the scales are of equal sizes. Thirdly, the coloration is different. The ground is blackish olive, and there is a black dorsolateral band which has a not very distinct pale dorsal border. A faint pale median dorsal band is bordered on each side by a narrow black line. There are small pale dots on various scales, which

are especially conspicuous on the sides of the body and tail. On the latter they are arranged in transverse rows. Fore legs blackish with pale variegations; hind legs blackish. The black lateral band extends to the end of the muzzle, and a less regular one extends from the orbit to the humerus. Head above pale brown. Fourth, the tail is compressed; in *M. assata* the section is round.

Measurements.

	MM.
Total length	56
Length of head and body.....	23.5
Length to axilla	11
Length of fore limb.....	7
Length of hind limb	10

Palmar; No. 292. This species, the second one of the genus found in America, is dedicated to Mr. George K. Cherrie, the well-known zoölogist of San José, who has added much to our knowledge of the life of Costa Rica.

GYMNOPHTHALMUS LÆVICAUDUS Cope. *Tretioscincus levicaudus* Cope.
Epaphelus sumichrasti Cope. *Gymnophthalmus sumichrasti* Boulenger.

No. 287, Terraba.

AMIVA QUADRILINEATA Hallow. (*Cnemidophorus*). *A. gabbiana* Cope,
Journ. Acad. Phila., 1875, p. 117, Pl. 28, Fig. 3.

Why Boulenger regards this lizard as identical with the *A. undulata* is difficult to understand. The differences are numerous, that in the form and size of the gular scales being especially marked. The species was characterized by Hallowell from small individuals; the present collection contains one (No. 379) which measures (with tail) 205 mm., which equals the types of *A. gabbiana*.

Nos. 303, 313, 322-324, Buenos Ayres; 373, Lagarto; 379, Boca Sacate.

I have before me fifteen specimens of *A. undulata*, and find that ten of these have three supraorbital plates and four have four. In none of them are the gular scales so small as in the *A. quadrilineata*. The specimens are from various localities between middle Vera Cruz and Guatemala inclusive.

AMIVA FESTIVA Licht.

Boruca, No. 325; one specimen.

AMIVA LEPTOPHRYS, sp. nov.

Abdominal plates in eight rows, those of the external row as large as those of the next row. Keels of caudal scales forming straight lines. Gular scales larger in several longitudinal rows, the two median especially

enlarged. One row of seven very large scales on the mesopterygium. Anal scuta consisting of two large medians surrounded by numerous smaller scales, separated by several rows from the vent. Femora with only three rows over the distal fourth of the length; within this point small rows separate the plates from the femoral pores; the latter twenty-four in number. Tibial plates in three rows, those of the internal very small; no heel spurs. The heel of the extended hind limb reaches the elbow. Five large labials below the orbit. One postnasal and one large loreal longer than high. Two preoculars, wide and keeled at their middle. A preculo-loreal resting on the labials. Six inferior labials and six infralabials, the last small. Three supraorbitals; first and second longer than wide, the third long as wide. Two parietals on each side; the interparietal separated from them and the frontoparietals by small scales.

Color brown above and olivaceous below. On the line where the back passes into the side, a series of dark-brown spots situated close together, and presenting angles upwards and downwards. There are about a dozen between the groin and the scapular region, and a series of indistinct pale spots is seen between their inferior apices. From their superior apices, narrow and indistinct dark-brown lines cross the back, sometimes alternating with each other on the median line.

Measurements.

	MM.
Length to extremity of tail.....	327
Length to vent	102
Length to axilla.....	37
Length to posterior border of ear (axial)	25
Length of fore leg.....	42
Length of fore foot.....	19
Length of hind leg.....	88
Length of hind foot.....	47

From Buenos Ayres, No. 318; one specimen.

This species is allied to both the *A. festiva* and *A. undulata*, but differs from both materially in the scutellation of the head. The middle and posterior supraorbital plates are broader than long in these species, and the superior preocular is narrower, and is keeled near to its anterior border in whole or in part. The interparietal plate is in contact with the surrounding scuta, and not, as in *A. leptophrys*, surrounded by small scales.

CELESTUS STEINDACHERII Cope.

From Boruca; No. 300; one specimen. This individual has thirty-six longitudinal series of scales, which have nine longitudinal keels on the middle and posterior parts of the body and on the tail, and are without prominent median keel. Anterior scales smooth. Two prefrontals. This specimen presents characters of both the *C. steindachnerii* and the *chaly-*

bæus Cope, and in some respects differs from both. Whether there is one variable species or not, more abundant material is necessary to decide.

CTENOSAURA, sp. young, Nos. 376, 377.

IGUANA TUBERCULATA, L., No. 378.

ANOLIS LONGIPES, sp. nov.

Size of *A. biporcatus*; head short, wide; limbs long, the posterior when extended reaching the end of the nose. Tail cylindrical, covered with scales of equal size, which are freely keeled above and below. Tibia equal length of head to auricular meatus, and longer than length to occiput. Scales of body of medium size, subequal, those of belly imbricate and keeled; those of back not imbricate and smooth. Occipital plate rather smaller than the large auricular meatus, and separated by two rows of scales from supraorbital rows. The latter are separated from each other by two rows of scales. Frontal ridges well defined, and separated from each other by five and six rows. Five loreal rows and six supraorbital rows, the latter diminishing in size gradually outwards. Scales of limbs keeled. Scales of top of head, including supraorbitals, with a single keel. Tail elongate.

Color brown above, dirty white below. A dark-brown band originates on each side of the occiput, and extends continuously on the basal part of the tail. On the body a delicate brown line extends above and parallel to it. A dark-brown cross band between orbits, and a dark-brown chevron with the angle pointing backwards on the prefrontal concavity. Four broad dark cross-bands across lips; limbs indistinctly cross-banded.

<i>Measurements.</i>	MM.
Total length.....	245
Length to vent.....	83
Length to axilla.....	40
Length to auricular meatus posteriorly.....	23
Width at auricular meatus posteriorly.....	16
Length of fore limb.....	39
Length of fore foot.....	17
Length of hind limb (to acetabulum).....	80
Length of hind foot.....	34

Palmar, No. 343, adult; No. 299, Boruca, young.

The small size of the fan in No. 343 indicates that it is a female; it is much better developed in the young, No. 299, which is quite small. In the young, the scales of the head are not keeled, and the keels of the adominal scales are less distinct. The color is a bright yellow, with a broad brown band surrounding the head above and below at the orbit, and another capping the nose and chin, the loreal region remaining yellow. The yellow cross-band on the chin which separates these two areas leaves a visible trace on the adult.

This species is allied to the *A. bransfordii* Cope, which has been found so far in Nicaragua only. The *A. bransfordii* was described from a specimen about half the size of the type of *A. longipes*, but of very similar proportions. In various details of structure they are similar, but in the *A. bransfordii* the scales of the head and belly are smooth, and the latter are longer than the dorsal scales. The latter are quite small, which cannot be said of those of the *A. longipes*. Finally the coloration is very different. The affinities of *A. longipes* to *A. capito* Pet. are not distant. In the latter species the head is still shorter and wider, and it is covered above and on the sides with larger and fewer scales, which are without keels.

ANOLIS INTERMEDIUS Peters.

San José, No. 338.

ANOLIS TROCHILUS Cope.

Palmar, 319; Sierpe, 383, 384; loc? 291. No. 384 is a male with very large fan. There is a trace of carination on the median dorsal scales, and the tail is compressed, and the median superior row of scales form a rather prominent serrate outline.

BASILISCUS VITTATUS Wieg. From Sierpe.

OPHIDIA.

COLOBOGNATHUS HOFFMANNI Peters.

San José, No. 347.

RHADINÆA IGNITA Cope.

Boruca, No. 348. This specimen differs from the type in having only one preocular plate, and in having the angle of the third superior labial plate enter the orbit. The first-mentioned character was variable in the specimens which served as types. In coloration the dots on the gastrosteges are confined to the anterior sixth of the body, and the belly is yellow and not red. There are 117 gastrosteges, while in the type there are 128. Bocourt has shown the great variability in the number of gastrosteges in this genus. I suspect, however, that the specimen sent by Mr. Cherrie represents a local race.

DRYMOBIUS RHOMBIFER Peters.

Palmar, No. 382.

DRYMOBIUS CÆRULEUS Fisch.

Boruca, No. 381.

DRYMOBIUS PERCARINATUS, sp. nov.

Scales lanciform, in seventeen longitudinal rows, all keeled except the first, the second feebly. Head elongate; eyes large, their horizontal diameter equal the space from their anterior border to the posterior border

of the rostral plate. Rostral plate a little visible from above; internasals subquadrate; frontal about as wide at middle as each superciliary, and a little shorter than the parietals. Loreal longer than high; one preocular, which does not reach the frontal. Two postoculars, the superior the longer, and half bounded posteriorly by the parietal. Temporals, 2-2, the anterior elongate. Superior labials nine, fourth, fifth and sixth in orbit; all longer than high, except the second, which is quadrate, and the seventh, which is subtriangular. The eighth is much the longest. Inferior labials ten; genials long, the posterior the longer. Gastrosteges 155; anal 1-1; urosteges 145.

Color above, brown; below, cream color. Small rusty spots appear on the sides throughout the length, at intervals of two scales, on the fourth or fourth and fifth rows; and they are bounded posteriorly by a small deep brown spot. From the middle of the body posteriorly, the first three rows of scales are paler than those above them, and the third row carries a small black spot on each scale. These spots become confluent into a narrow stripe, which is distinct on the posterior fourth of the body and on the side of the tail. The scales of one and two rows above this stripe are paler than those of the median dorsal region. Head uniform brown, upper lip and below uniform yellowish.

Total length 815 mm.; total length of tail 352 mm.; length of head to canthus oris, 20 mm.; interorbital width 8 mm.

Boruca, No. 326, adult; Buenos Ayres, No. 336, young. In the young, the anterior half of the body presents the cross-bars characteristic of the young of this genus. On the posterior half the cross-bars are broken up into a series of small dark spots on each side, and a narrow longitudinal lateral stripe below them, as has been already shown to exist in the adult.

SYNCHALINUS CORALLIGIDES, gen. et sp. nov.

Char. gen.—Teeth equal, smooth. Scales with two terminal fossæ. Body compressed, gastrosteges sharply angulated near extremities; head distinct. Pupil round. Anal plate entire; subcaudals in two rows. Cephalic plates normal except that the nasals and loreal are fused into a single, elongate plate.

In this genus we have apparently a colubrine snake of arboreal habits, which has assumed a boæform character rather than that characteristic of the tree-snakes proper. In the thin scales and fusion of lateral head plates we have a resemblance to the little known genus, *Amastridium*, but that form is of entirely terrestrial habit.

Char. specif.—This snake has at first sight considerable resemblance to some of the color varieties of the tree-boá, *Corallus hortulanus*. In its color tints and patterns it also resembles the *Spilotes lunulatus* m. The body and tail assume a coiled attitude in spirits like the species of *Corallus*, and the sharp angles of the gastrosteges show that the habits are similar.

Scales in twenty-three rows, the first and several median composed of

the largest scales. Three or four median rows faintly keeled on the posterior three-fourths the length of the body. Muzzle subtruncate; eye large, its horizontal diameter equal the distance from its anterior border to the posterior border of the rostral plate. Rostral plate slightly visible from above; internasals subquadrate; prefrontals wider than long. Frontal shorter than superciliaries, with concave lateral borders; as wide at the middle as a superciliary. Parietals as wide as long, and regularly rounded in posterior outline. Nasal part of the nasoloreal plate with the superior and inferior borders parallel; the superior border posterior to the nasal part, sloping downwards to a subacute angle with the inferior border, which is in contact with the wide preocular. The latter barely reaches the frontal on one side, and fails to do so on the other. Postoculars two, the superior larger and half bounded posteriorly by the parietal. Temporals 2-2; the inferior anterior temporal in contact behind with the parietal. Superior labials eight, the last very long on both sides, and probably consisting of two plates fused. Fourth, fifth and sixth plates bounding orbit, the seventh a horizontally placed parallelogram. Inferior labials 12-13, much divided anteriorly, the posterior six all longer than deep. Genicals elongate, the posterior pair longer. Gastrosteges 209; anal 1; urosteges 134. Total length 450 mm.; length of tail 125 mm.; length of head to rictus oris 20 mm.

The ground color of the upper surfaces of this snake is a rich yellowish brown. On the narrow dorsal region is a median series of parallelogrammic spots of an iron-rust color, each of which has a small blackish spot at its anterior extremity. On the sides are wide vertical spots of iron-rust color, which are of equal width with the length of the dorsal spots, and which sometimes coincide with the latter, forming with them broad crossbands. The chin and throat are cream-colored, but this color becomes clouded, first with light, then with darker brown, and then with rusty red with blackish specks, till the middle line of the abdomen posteriorly is a dark mahogany. Opposite each vertical lateral bar is a dark spot on the upturned extremity of the gastrostege. These become darker posteriorly, forming subquadrate mahogany spots. Immediately below them a wide pale border further varies the colors of the abdomen. A dark-brown band passes to the neck posterior to the eye, and three descend from the eye across the upper lip. Top of head rich yellowish brown, with a mahogany spot on the posterior part of the prefrontal common suture, the posterior part of the frontal, on the middle of each parietal, and on the posterior external border of each parietal. Loreal region mahogany. Black spots on the anterior and middle inferior labial plates.

Buenos Ayres, one specimen, No. 340. This is a handsome species, whose colors are well calculated to conceal it on tree trunks and branches where rusty colors predominate. In general character they are a good deal like those of the *Amastridium veliferum* of Veragua.

SIBON SEPTENTRIONALE Kenn., subsp. RUBRICATUM.

No. 346, from Boca Mala, represents a form of this species to which sub-specific rank may be at least accorded. If additional specimens confirm the characters it may even rank as a species. A decision cannot now be reached, as only a single specimen has been sent by Mr. Cherrie.

In this form the body is robust, and the head is not separated by a narrow neck, although the temporal region is somewhat swollen. The muzzle is short, and there are eight superior labials, of which the fourth and fifth enter the orbit. Oculars, 2-2, the lower preocular, labial. Twenty-three rows of scales. Five undivided scuta posterior to the vent. The color of the dorsal regions is bright red; of the inferior regions, light salmon color dusted with brown. There are sixty-one transversely oval black spots on the back, which cover twelve rows of scales transversely, and two and a half to three and a half rows longitudinally. Small black spots alternate with them on the third row of scales; and a less definite row of smaller spots alternate with these on the second and third rows. A black band extends from the eye to the last labial plate, and behind and above it a parallel black band extends from the parietal plate. The extremities of these bands are fused with the first dorsal spot, the interspaces being red. Superior labials red, with a black spot in the centre of each plate. Inferior labials black spotted. Top of head dark brown, bordered posteriorly on outline of parietal plates by a red crescent. This is bordered posteriorly by a black crescent, and is traversed by a median black stripe which connects the dark brown of the vertex with the anterior four black dorsal spots. Tail blackish red, spotted above. Total length, 660 mm.; of tail, 133 mm.

I have seen the Mexican *Sibon septentrionale* living, and the ground color is light brown, and not red. The color pattern of the form *rubricatum* is peculiar about the head, but in other respects it resembles individuals of the *S. septentrionale* which have numerous dorsal spots.

OXYBELIS ACUMINATA Wied.

Terraba, No. 289; No. 385 without locality.

ELAPS NIGROCINCTUS Girard.

Buenos Ayres, No. 341; Boruca, No. 329.

Summary.

	NO. OF SPECIES.	NEW SPECIES.
Urodela.....	2	1
Salientia.....	10	3
Lacertilia.....	12	3
Ophidia.....	9	2
	—	—
Totals.....	33	9

Stated Meeting, November 3, 1893.

Secretary, Dr. DANIEL G. BRINTON, in the Chair.

Correspondence was submitted as follows :

Letters of acceptance of membership were received from (2221) Dr. Samuel A. Green, Boston, Mass.; (2222) Dr. John G. Morris, Baltimore, Md.; (2224) Prof. J. M. Hoppin, New Haven, Conn.

A letter of resignation was received from Hon. Joseph Allison, Philadelphia, and on motion the resignation was accepted.

The following were placed on the Proceedings exchange list: Société Scientifique du Chili, Santiago de Chili; Oberlin College Library, Oberlin, Ohio; Texas Academy of Science, Austin, Texas; Enoch Pratt Free Library, Baltimore, Md.; Institute of Jamaica, Kingston, Jamaica; Journal of the U. S. Artillery, Fortress Monroe, Va.; Rassegna delle Scienze Geologiche, Rome, Italy; Royal Microscopical Society, London, England; University of the State of Missouri, Columbia, Mo.; Observatorio Meteorologico-Magnetico Central, Mexico, Mex.; State Historical Society, Lincoln, Neb.; Faculté des Sciences, Marseilles, France; Société Physico-Mathématique, Kasau, Russia; Society of Bohemian Students, Prague, "Slavia," Bohemia; University Quarterly, Lawrence, Kans.; California State Mining Bureau, San Francisco, Cal.

Accessions to the Library were reported from the K. Svenska Vetenskaps Akademie, Stockholm, Sweden; R. Académie des Sciences, Amsterdam, Netherlands; K. Bibliothek, 'S Gravenhage, The Hague; Académie Royale de Belgique, Bruxelles; Magyar Tudományok Akadémiai, Budapest, Hungary; Senckenbergische Naturforschende Gesellschaft, Frankfurt a. Main, Germany; R. Accademie dei Lincei, Institut International de Statistique, Rome, Italy; Canadian Institute, Toronto; Yale University, New Haven, Conn.; Geolog-

ical Society of America, Rochester, N. Y.; Indian Rights' Association, Messrs. MacCalla & Co., Philadelphia; Department of State, Bureau of Education, Washington, D. C.; Dr. John Mallett, University of Virginia; Agricultural Experiment Stations, Orono, Me., Providence, R. I., Raleigh, N. C.; Board of Education of School District No. 1, Denver, Colo.; Sociedad Mexicana de Historia Natural, Messrs. José G. Aguilera y Ezequiel Ordonez, Mexico, Mexico.

The following deaths were announced: Dr. C. Leemans, Leiden, October 14, 1893, æt. 84; Furman Sheppard, Philadelphia, November 3, 1893 (b. November 21, 1823).

On motion, the President was authorized to appoint a suitable person to prepare the usual obituary notice of the latter.

Prof L. M. Haupt made some remarks on the proposed Atlantic Coast Ship Canal. He advocated the canal which is to connect the waters of the Delaware river with those of New York harbor. Such a canal, he said, would reduce the distance by water to the coal fields from New York city. As there are over 6,000,000 tons of coal consumed annually in New York alone, the saving in this item would be not less than \$3,000,000, which is the interest of \$50,000,000, or about four times the estimated cost of the work. The canal would appear to be needed by the ports of both New York and Philadelphia. The commerce of Philadelphia especially would be greatly stimulated by such a water-way. Cheap transportation was the basis of his remarks. What was advocated is the construction of a deep draught canal. It would be quite as practicable to ship freight by this canal as it is by railways, and quite as economical and rapid.

Prof. Haupt then detailed the operations of the great canals of the world. Leaving the Suez and Nicaragua canals out of the question, he said no canal accomplishes such a great saving as this one would.

A resolution read in the Senate by Senator Higgins was then quoted by Prof. Haupt, asking that the Secretary of War be "authorized and directed to cause a survey and examination to be made, at the earliest practicable time, for the lo-

cation of a ship canal from Philadelphia across New Jersey to New York Bay.”

With these water-ways open, it would be of great advantage to the United States in war time. Except in an exceedingly severe winter the canal could be kept open by running ice-boats.

The following resolution, offered by Dr. J. Cheston Morris, was unanimously adopted :

That Prof. Haupt's proposition for a ship canal between New York and Chesapeake Bay be referred to Council for consideration and recommendation of such action, if any, as it may deem advisable for the Society.

Dr. Brinton made some remarks upon a Nanticoke Indian Vocabulary compiled for President Jefferson in 1792, in the possession of the Society, dilating upon its value as the only surviving relic of that language. On motion of Mr. Smyth, Dr. Brinton was requested to edit and prepare the same for publication in the Society's Proceedings.

Prof. Cope presented a paper for the Proceedings on a new genus *Tomiopsis*.

Mr. Prime called attention to a new gold field in Western Australia. About 350 miles east of Perth, the chief city of the Colony, slate occurs broken through by dykes of diorite. The country is very arid, so much so that water has to be transported for watering stock and is sold at fifteen cents per gallon. The gold deposit has been opened to but a slight depth. At the outcrop the bonanza is but two feet wide and about ten feet long; at a depth of about twelve feet it widens to four feet, while the length is doubled. Several tons of ore have been taken out, which carry 2000 ounces of gold to the ton, which is probably the richest ore hitherto found. The gold occurs very coarsely distributed in quartz. The gold is separated by screening and then blowing the gangue away by air-blast. Owing to the richness of the ore, the owners work the mine themselves, being afraid to trust hired miners.

And the Society was adjourned by the presiding member.

Stated Meeting, November 17, 1893.

President, Mr. FRALEY, in the Chair.

A circular was received from the Wyoming Historical and Geological Society, Wilkesbarre, Pa., inviting the Society to be present at the opening of its new building, Nov. 20, 1893.

Letters of envoy were received from the Geological Survey of India, Calcutta; K. Svenska Vetenskaps Akademien, Stockholm, Sweden; Royal Academy of Sciences, Amsterdam, Netherlands; Ministero della Instruzione Publica, Rome, Italy; Schlesische Gesellschaft für Vaterländische Cultur, Breslau, Prussia; K. Sächsische Gesellschaft der Wissenschaften, Leipzig; Central Bureau der Internationalen Erdmessung, Potsdam, Prussia; Geological Society of America, Rochester, N. Y.; Bureau of Education, Washington, D. C.; Kansas University, Lawrence, Kans.

Letters of acknowledgment were received from the Public Library, Wellington, N. Z. (140); China Branch of the Royal Asiatic Society, Shanghai (139, 140); Imperial Academy of Science (141), Observatoire Physique Central (141), Prof. Sergé Nikitin (139-141), St. Petersburg, Russia; Prof. Japetus J. Steenstrup, Copenhagen, Denmark (141); Académie Royale des Sciences, Amsterdam, Netherlands (137-140, and Trans., xvii, 1, 2); K. K. Astronomisch-meteorologische Observatorium, Triest, Austria (139, 140); K. K. Geologische Reichsanstalt (140), Dr. Aristides Brezina, Prof. Dr. Friedrich Müller, Vienna, Austria (141); K. Geodätisches Institut, Potsdam, Prussia (140, 141); Redaction der *Naturwissenschaftlichen Wochenschrift*, Berlin, Prussia (139); University of Bonn (140); Naturforschende Gesellschaft, Emden, Prussia (139, 140); Geographische Gesellschaft, Hamburg, Germany (140, 141); M. Otto Böhlingk, Leipzig, Saxony (141); Verein der Freunde der Naturgeschichte, Mecklenburg, Germany (140); Prof. Guido Cora, Turin, Italy (140); Académie des Sciences et Belles-Lettres, Angers, France (140); Société d'Histoire et d'Archéologie, Chalon s. Saone, France (141); Université de

Lyon, Lyon, France (141); Redaction de Cosmos, Cmte. de Charencey, M. Victor Duruy, Profs. E. Mascart, Gaston Maspero, Marquis de Nadaillac, Paris, France (141); Society of Antiquaries, London, England (141, and Trans., xvii, 3, xviii, 1, 2); Royal Geological Society of Ireland, Dublin (141, and Trans., xvii, 3, xviii, 1); Prof. James Geikie, Edinburgh, Scotland (141); American Antiquarian Society, Worcester, Mass. (141); University of the State of New York, Albany (141); Prof. W. L. Hewett, Ithaca, N. Y. (137-141); Bureau of Ethnology (139), Prof. C. V. Riley, Washington, D. C. (141); Nebraska State Historical Society, Lincoln (140, 141); California Academy of Sciences, San Francisco (137-139, 141).

Accessions to the Library were reported from Prof. O. A. L. Pihl, Christiana, Norway; Association Gécodésique Internationale, Bruxelles, Belgium; K. K. Central Anstalt für Meteorologie und Erdmagnetismus, Vienna, Austria; Schlesische Gesellschaft für Vaterländische Cultur, Breslau, Prussia; Verein für Geographie u. Statistik, Frankfurt a. M. Germany; Naturhistorische Gesellschaft, Nürnberg, Bavaria; Nassauische Verein für Naturkunde, Prof. F. v. Sandberger, Wiesbaden, Prussia; Ministero della Instruzione Publica, Rome, Italy; Société Autopsie, Société N. d'Acclimation, Paris, France; Islenzka Fornleifafélag, Reykjavik, Iceland; Peabody Education Fund, Cambridge, Mass.; Prof. John Henry Comstock, Ithaca, N. Y.; Dr. Charles A. Oliver, Messrs. Henry Phillips, Jr., Frederick Prime, Philadelphia; California State Mining Bureau, Sacramento, Cal.; Kansas University, Lawrence.

Photographs for the Society's album were received of Hon. Frederick Fraley, Drs. D. G. Brinton, J. C. Morris, Mr. William A. Ingham, Mr. Joseph Zentmayer, Prof. E. Otis Kendall.

Announcements were made of the death of M. Karl Chevalier Rousseau d'Happoncourt, Captain of the Imperial and Royal Ship of the Line, *Fruntsberg*, at Pola, Austria, October 26, 1893, æt. 51; and of Prof. Hermann August Hagen, Cambridge, Mass., November 9, 1893, æt. 76.

The President reported the appointment of Mr. McKean to

prepare the obituary notice of Mr. Furman Sheppard, and that he had accepted the same.

The President reported the appointment of C. Stuart Patterson, Esq., a member of the Henry M. Phillips Prize Essay Committee, to fill the vacancy occasioned by the death of the late Furman Sheppard.

A paper on "The Conservation of Osmazome in Roasting," was read by Mr. R. Meade Bache.

Prof. Cope presented for the Proceedings a "Second Contribution to the Batrachia and Reptilia of Costa Rica."

The proceedings of the Board of Officers and Council were submitted, as follows :

COUNCIL.

Stated Meeting, November 10, 1893, 8 P.M.

Present : Messrs. Phillips, Tatham, Horn, Morris, Brinton.

Dr. Cattell in the chair.

Minutes of last meeting were read, and after discussion were adopted.

A letter from the President was read, stating that, owing to a prior engagement, he was unable to attend, and suggesting, should anything be laid before Council of sufficient importance, a special meeting should be called. [See letter file, 1893.]

Pending nomination No. 1249, which had been referred by the Society to the Council, was taken up and considered. A letter from pending nomination 1249, soliciting membership, was read. After discussion it was unanimously the opinion of the Board that the old custom of the Society in regarding as disqualified a person who has solicited membership in the Society was a good rule, and should be continued.

On motion of Dr. Brinton, seconded by Dr. Morris, pending nomination No. 1249 was laid on the table.

On motion of Dr. Brinton, Messrs. Brinton, Phillips and Morris were appointed a Committee to prepare for election to membership a list of distinguished men [pursuant to the Laws of the Society, Chap. vii, Sec. 4] "of our own or foreign countries, as may in their judgment merit such distinction ;" and to report such list at the next stated regular meeting of Council.

Prof. Haupt, who was present by invitation, explained fully the nature and object of the proposed Atlantic Coast Ship Canal, from New York to the South ; and stated that, in his opinion, the best method in which the Society could coöperate was by helping to create and enforce a public sentiment in favor of the project. After discussion it was

Resolved, That when the Board of Officers and Council adjourn this evening, it shall be

adjourned to meet at the call of the President, at such time and place as he shall designate, to consider a memorial on the subject to Congress, the rough draft of which will be prepared for submission at that time by Prof. Haupt.

And at 9.30 p.m. the Council was adjourned by the presiding member.

Adjourned Meeting, Thursday, November 16, 1893, at 2 P.M.

Present : Messrs. Tatham, Ingham, DuBois, McKean, Morris, Price, Wurtz, Phillips, Cattell.

President Fraley in the chair.

Prof. Haupt, who was present by invitation, explained the object of the meeting, and submitted a preamble and resolutions, which, after discussion and amendment, were unanimously adopted, as follows :

The Board of Officers and Council of the American Philosophical Society, to whom was referred the question of the ship canal along the Atlantic coast, has the honor to report :

That after due consideration of the subject in its various bearings, it would recommend the Society to prepare and transmit a memorial to Congress urging definite and immediate action by the United States, and to this end it has prepared the accompanying draft of the same, which is respectfully submitted as a basis for action.

Whereas, The construction of interior deep draught water communication along the seaboard is of the utmost importance in a military point of view, and would have great incidental commercial advantages in time of peace ; it is, therefore,

Resolved, That the American Philosophical Society respectfully memorializes your honorable bodies to make such appropriations for the examinations, surveys and reports upon the more important links in this system, especially as to the connection between New York bay and Delaware river, and between Delaware bay and Elk river, as in your judgment may be considered sufficient to inaugurate the work.

And your petitioners will ever pray.

On motion of Dr. Morris, the action on pending nomination 1249 was reconsidered.

Various suggestions and resolutions were offered, and ultimately, upon motion of Dr. Morris, the Council resolved unanimously to report to the Society unfavorably upon nomination 1249.

And at 3.30 p.m. the Council was adjourned by the President.

On motion of Mr. Prime, the consideration of the proposed memorial to Congress was postponed until the next stated meeting of the Society, announcement of the same to be placed on the meeting notices.

The President stated, in reply to a question, that the unfavorable report upon nomination 1249 had the same effect as a similar action upon the part of a committee of a legislative or deliberative body.

New nominations Nos. 1265, 1266, 1267, 1268 and 1269 were read.

Pending nomination 1249 was read.

And the Society was adjourned by the President.

Stated Meeting, December 1, 1893.

Secretary, Dr. BRINTON, in the Chair.

Photographs of Dr. Ruschenberger and Dr. Wurtz were received for the Society's album.

The President reported the following as the Committee under the resolution of Mr. Williams to consider a plan for a general Index of all Transactions, viz.: Messrs. Williams, James, Brinton, Horn, Price.

The death of Thomas M. Cleemann (Nov. 16, 1893, æt. 50) was reported, and the President was authorized to appoint a suitable person to prepare the usual obituary notice. Mr. Frederick Prime was subsequently appointed.

The Treasurer's report was presented and referred to the Finance Committee.

The Publication Committee reported.

The pending resolution relative to the Atlantic Coast Ship Canal was taken up and considered. After discussion by Messrs. Prime, Morris, Haupt, Cope, Dolley, *et al.*, the Society adopted the resolution reported by Council on November 17.

Dr. Cope made an oral communication on "*Spermatodus pustulosus*," from the Permian beds of Texas.

Pending nominations 1249, 1265, 1266, 1267, 1268 and 1269, and new nominations 1270, 1271, 1272, 1273 and 1274 were read. On motion of Dr. Morris, nominations 1268, 1269, 1270, 1271, 1272, 1273 and 1274, being of non-resident members, were referred to Council to examine and report upon the same before action should be taken thereon by the Society.

And the Society was adjourned by the presiding member.

Stated Meeting, December 15, 1893.

President, Mr. FRALEY, in the Chair.

Dr. Charles Schäffer was presented to the Society and took his seat.

The President reported that the memorial authorized by the Society at its last meeting had been signed, and presented to Congress by Senator Cameron and Representative Harmer.

Letters of envoy were received from the Ministère des Travaux Publics, Paris, France; Société de Géographie de Toulouse, France; Royal Statistical Society, Zoölogical Society, London, Eng.; Royal Irish Academy, Dublin; Literary and Historical Society, Quebec, Canada; Bureau of Ethnology, Washington D. C.; Wisconsin Academy of Sciences, Arts and Letters, Madison; Colorado Scientific Society, Denver, Colo.; Geological Survey of Texas, Austin.

Letters of acknowledgment were received from Institut Egyptien, Cairo (139, 140); Comité Géologique de la Russie, St. Petersburg (139-141); Societas pro Fauna et Flora Fennica, Helsingfors (139-141); Akademia Umiejetnosci, Krakow, Austria (139-141); Prof. Peter R. von Tunner, Leoben, Austria (139-141); Anthropologische Gesellschaft (140, 141); Dr. Friedrich S. Krauss, Vienna, Austria (141); Naturforschende Gesellschaft des Osterlandes, Altenburg (141); Anthropologische Gesellschaft, Berlin, Prussia (141); Universitäts Bibliothek, Bonn, Prussia (141); K. Sächs. Meteorologische Institut, Chemnitz, Saxony (141); Geographische Gesellschaft, Naturhistorische Gesellschaft, Hannover, Prussia (140); Naturwissenschaftlicher Verein für Schleswig-Holstein, Kiel, Prussia (140); K. Sächs. Gesellschaft der Wissenschaften (137, 141); Prof. I. Victor Carus, Leipzig, Saxony (141); Société de Physique et d'Histoire Naturelle, Geneva, Switzerland (140); R. Comitato Geologico d'Italia, R. Accademia dei Lincei, Rome, Italy (141); Musée Guimet (141), Dr. Edward Pepper (139, 140), Paris, France; Royal Society (141, and

Trans., xvii, 3 ; xviii, 1), Geological Society (141, and Trans., xvii, 3 ; xviii, 1), Dr. W. H. Flower (140, 141), London, Eng.; Radcliffe Observatory, Oxford, Eng. (141, and Trans., xvii, 3 ; xviii, 1); R. Geological Society of Cornwall, Penzance, Eng. (141); Mr. Joseph Prestwick, Kent, Eng. (139); Academy of Science, Rochester, N. Y. (140, 141); State Mineralogist, San Francisco, Cal. (140, 141); Dr. C. S. Dolley, Philadelphia (140); Smithsonian Institution, Washington, D. C. (137-139); Museo Nacional, Buenos Aires, S. A. (136-138).

Accessions to the library were reported from the Nederlandsche Botanische Vereeniging, Nijmegen; M. Richard Wagner, Jena, Germany; Ministère des Travaux Publics, Paris, France; Victoria Institute, Editors of *Nature*, London, Eng.; Literary and Historical Society, Quebec, Canada; Indian Rights Association, Dr. C. A. Oliver, Mr. Henry Phillips, Jr., Philadelphia; U. S. Coast and Geodetic Survey, Bureau of Ethnology, Washington, D. C.; Academy of Sciences, Austin, Texas; University of California, Berkeley; Agricultural Experiment Station, Fayetteville, Arkansas.

An obituary notice of the late Joseph Zentmayer, by Dr. Charles A. Oliver, was presented.

The following deaths were announced :

Joseph D. Potts, Philadelphia, December 3, 1893, æt. 64.

John Tyndall, London, December 5, 1893, æt. 74.

On motion, the President was authorized to appoint a suitable person to prepare an obituary notice of the late Joseph D. Potts.

The appropriations for the ensuing year were deferred until the next regular meeting of the Society.

This being the evening for balloting for candidates for membership, nominations Nos. 1249, 1265, 1266, 1267 were read, spoken to and balloted for.

Pending nominations Nos. 1268-1274 were read.

A communication entitled, "A Tabulation of the Movement of Civilized Society Westward in the Natural Order of Time," was presented through the Secretaries with a negative recommendation.

On motion, the Secretaries were instructed to return the same to the author as undesirable for publication by the Society.

Dr. Cope presented for the Proceedings a paper by Prof. Jesse W. Hubbard, entitled, "The Yolk Nucleus in *Cymatogaster aggregatus*."

Dr. Cope made some remarks upon the results of late explorations by Mr. Henry C. Mercer, of the Durham Cave of Bucks county, Pa., near Easton, and of Hartman's cave, Monroe county, Pa., near Stroudsburg.

Dr. Brinton spoke of the negative results from the researches heretofore made by Mr. Mercer in American caves, as furnishing no evidence of the existence of a race prior to the Indian inhabitants of this continent.

After all the other business of the meeting was ended, the ballots cast were counted by the Tellers, who reported to the President that the formalities necessary for election to membership had not been fulfilled in the present instance.

And the Society was adjourned by the President.

*Obituary Notice of Joseph Zentmayer.**

By Charles A. Oliver, M.D.

(Read before the American Philosophical Society, December 15, 1893.)

"Two things," says Kant, "fill me with awe, the starry heavens and the sense of moral responsibility in man," but how insignificant are these wonderful words to that marvelous expression,

"Whene'er a noble deed is wrought,
Whene'er is spoken a noble thought,
Our hearts in glad surprise
To higher levels rise. . . ."

of one of America's greatest teachers of poetical truth. So here, when it becomes the duty of one to give the life history of another greater than

* The writer is under obligations to Prof. Ryder and many others for the facts and dates herein given.



JOSEPH ZENTMAYER.

himself, and to tell that story truthfully to those who have better and greater understanding of the details of that life's work than himself, the task becomes not only necessarily difficult, but doubly a happiness. So to the present memoirist, although knowing the subject of this sketch most intimately in his chosen pursuit, yet he feels a deep sense of duty and doubt in action when confronted with an undertaking which he can do no less than denominate as a labor of love.

His first meeting with Mr. Zentmayer was some thirteen years ago, when he found himself ushered into a most curious little workshop on Fourth street above Walnut street, replete with all manner of cumbersome, peculiarly shaped and intricate devices in what seemed old steel and dirty brass; from the midst of which, the plain though truly honest face of Teutonic type welcomed him with a cheery "Good-morning!"

From that first acquaintanceship, the most revered and kindly friendship existed; a friendship which was only severed and broken upon the day that word came that he was no more—the day when the first knowledge of the loosening of the silver cord and the breaking of the golden bowl that bound and held him with us, was made known.

He left us, not for evermore, but passed from us filled with Beethoven's hope, as he, too, was about to tread into that great unknown way.

"Brüder, über im Sternenzelt
Muss ein lieber Vater wohnen."

Joseph Zentmayer first saw the light of day in Manheim, Baden, on the 27th day of March, 1826. After the completion of his studies in the town gymnasium, he found himself for the first time ushered into that work to which he was destined to contribute so much that is good and so much that is useful. After faithfully serving his apprenticeship with the optician of his native place, and obtaining the foundation of the knowledge and skill which has marked him as a correct analyzer and a wonderfully ingenious contriver of mathematical and optical instrumentation, he further increased his power of observation and improved his technique by associating himself with some of the principal optical establishments in Karlsruhe, Frankfort, Munich and Hamburg. At the last named place, he was under the tutelage of the world-famous Repsold brothers, and there received advantages which he put to account in the later construction of astronomical apparatus.

The rapidity of strength of his character, and the early maturity of his love for individual independence and national liberty made themselves the keys by which the recesses of his future life were opened. Republican in spirit, he actively vouchsafed his nation's unsuccessful stroke for freedom when he was about twenty-two years of age, thus bringing him into this country in the year 1848. For five years he nobly fought his battle of wage-earning in some of the best optical establishments in Baltimore, Washington and Philadelphia, until in 1853, with a single foot-lathe, a stout heart, willing hands, and a steadfast purpose, he began the manu-

facture of mathematical and optical instruments at the corner of Eighth and Chestnut streets.

One of his earliest orders was the construction of a large compound microscope for the late Dr. Paul B. Goddard. The excellence of the instrument and his continually increasing local reputation amongst the prominent scientific men soon secured him the patronage of many of the leading histologists, microscopists and mineralogists. These business connections soon brought with them the pleasant and ever extending social and scientific associations, so common and so universal amongst those whose life aims are for intellectual good and philosophical research. Although reticent to a degree and unassuming amongst large bodies of men, yet his uncompromising honesty of opinion when sought for, his constant willingness to help solve the most difficult problems in theoretical and applied optics, and the clear, forcible and logical manner with which he grasped and handled any subject in question, made men seekers of him rather than he of them.

Ever thus he was surrounded by distinguished men of all professions and occupations who were interested in microscopical and optical science; men, who as friends and brothers, sought his workshop to take his counsel in the solution of vexed problems in the laws of light; men, who as students came to him to gain his advice as to the best form of construction of instruments of precision; and aye, even overwise tyros willingly found in this patient and unassuming man the calm and dignified correction that they had not supposed themselves able to receive.

Most approachable; always cordial; unbiased in his feelings towards the crudities of individual belief; and unlimited in his liberality in regard to personal and national opinion, he embraced those qualities that make a man lovable, craved for, and sought after.

For nearly a quarter of a century he fought and rapidly subdued many of the vexatious questions in the construction of some of the most important mechanical details of the microscope, thus not only simplifying and perfecting the necessary apparatus, bringing greater ease, more comfort and superior results in technique to the practical microscopist, but obtaining those incentives and inducements for better and increased action. For these endeavors he received those official recognitions, by prize, medal, honorable mention and scientific distinction, that lead all honest and conscientious workers and observers to higher planes of employment.

As early as 1865 he received a diploma as an award for merit from the Massachusetts Charitable Mechanical Association, followed but nine years later by another from the Franklin Institute of this city. How much he was commended for in the receipt of the Elliott Cresson gold medal on the 18th of January, 1875, which was entrusted to the recommendation of the Franklin Institute of the State of Pennsylvania, by the provision of the founder's will, can only be guessed at by the following points of excellence—the marked superiority of general workmanship and finish; the

improved plan of setting the binocular prism; the introduction of a circular rotating and concentric stage; the plan by which exact amplification of the image in the binocular instrument is obtained; the invention of a direct vision-erecting prism; the improved and perfect (mark the word "Perfect") mechanical finger; the optical superiority of the lenses ("the lenses have no superiors"); and lastly, "for the erection and conduct of an optical establishment in our own city wherein work equaling the best done abroad is done on principles of honesty and thorough mechanical skill; and all this as the result of one unaided individual." The Franklin Institute of the State of Pennsylvania also deemed it wise to give a silver medal for the same reasons. These all-sufficient reasons—which were the embodiment of the combined opinion of the Committee on Sciences and the Arts of the Franklin Institute, a committee composed of such representative men as B. Howard Rand, M.D., J. G. Hunt, M.D., George R. Morehouse, M.D., J. Solis Cohen, M.D., E. Otis Kendall, Charles M. Cresson, M.D., E. Thomson and H. C. Wood, Jr., none of whom as members of this Society are now with us in higher and more exalted positions—must bring vividly before us, in this later generation, the admiration and respect with which he was held at that time—a proof of scientific gratitude for individualized success, made still greater when it is known that its award was the second since its founding in the year 1848.

Listen to what the United States Centennial Commission for Awards at the International Exhibition held at Philadelphia in 1876 found sufficient reasons to offer a bronze medal for the microscope stands of Mr. Zentmayer: "For superiority of workmanship, rigidity and freedom from tremor, and the convenient arrangement of their moving parts as unsurpassed by any in use." "Besides the forms already familiar to microscopists, he has presented one which is substantially new, and which embodies a number of important improvements . . . this exceedingly ingenious stand is in every important respect original with the exhibitor, and is presented as a characteristically American stand." . . . "The objectives of 3-inch focus, 1½-inch, 1⁸/₁₀-inch, ½ inch, ¼-inch and ⅓-inch are not surpassed in defining power by those of any other maker." "The resolving power of the ¼ and ⅓-inch is also remarkable." . . . "For a pocket microscope which folds up without separation of parts into a case, which when in use forms its stand, and is small enough to be carried without inconvenience in the coat pocket." "For an admirable dissecting microscope, furnished at a low price." "Further, of the numerous forms of apparatus accessory to microscopic observations, exhibited by Mr. Zentmayer, may be mentioned as especially worthy of commendation, a very ingenious erecting prism, a mechanical finger for picking up and arranging diatoms and other minute objects," etc.

To this stand he added a most important arrangement, without which no microscope can be considered complete. This consisted in a swinging sub-stage, which, while carrying an achromatic condenser or illuminating apparatus, held a mirror which swung around a pivot placed behind the

stage, of which the axis passed through the object observed, so that the object is in the focus of the illumination in every position. This remarkably ingenious plan of swinging the substage and the mirror so as to have the object as its centre, induced numerous foreign and domestic makers to employ this important principle in optical construction.

Two years later, a third and most important honor was added to the list by the Committee of Awards on Microscopes at the Paris Exhibition, who found fit to give a silver medal and a diploma to Mr. Zentmayer for the superiority, manifold value and simplicity of his workmanship.

Recognizing the value and convenience of the Abbe system of condensing lenses or illuminator in stands that are provided with substages, he modified the ordinary form by so placing the carrier that the diaphragms can be readily changed and arranging the contrivance so that the diaphragm cannot only be moved over the field by rack and pinion, but that it can be revolved. How much we must praise his exquisitely simple, single-prism, total-reflecting camera lucida which is so contrived as to be used either in the upright, angular or horizontal positions of the draw-tube of the microscope.

How exasperatingly easy of comprehension and yet how excellently adapted for their purpose are his contrivances of the life current and siphon-slides so arranged in accordance with Mr. S. D. Holman's ideas that varying degrees of circulation in animalcules can be made visible, not only to the individual student at work with his highest powers, but actually made recognizable to large audiences during class-work instruction and lecture-room demonstration. Again, the wonderful mechanical construction of Prof. John A. Ryder's automatic microtome, where, with an ordinary razor, tissue-sections of .0025 mm. thickness can be cut by the merest novice, and objects to the length of fifteen centimetres and two centimetres wide can be completely cut serially into almost any desired thickness. Further, the botanical dissecting microscope designed and constructed to meet the requirements of Prof. J. T. Rothrock, of the University of Pennsylvania (a member of this Society), in his botanical class; his clinical stand for accurate examination of any object by a large class, by being passed from hand to hand, that the memoirist has so often used in his student-days; the cheapening and simplification of the microscope so as to bring a properly constructed and adequately working piece of apparatus into the hands of the student of limited means, thus allowing him to become an essential factor in scientific progress: these few contrivances are but a limited number of the mechanical triumphs that resulted from the employment of the never-ceaseless mind of Joseph Zentmayer (the optician), as he proudly styled himself, for more than a half century. Is it any wonder that we exclaim with Von Humboldt, "In the moral world there is nothing impossible, if we bring a thorough will to it. Man can do everything with himself."

An interesting incident in his life is the history of the patent of his doublet photographic lens, which is composed of two deep meniscus lenses

with their convex sides placed outwardly. He made the outer meniscus one-half larger than the back lens, thus allowing six different combinations with seven single lenses. Such a lens having an angle of nearly ninety degrees and great depth of focus, and giving extreme sharpness over the whole field, and being free from all distortion, necessarily became a most excellent instrument for architectural work and copying.

The story of the invention is this: One year before the patent of the lens was obtained, Mr. Coleman Sellers, who was at that time greatly interested in photography, requested Mr. Zentmayer to explain the theory of the then favorably known "Globe lens." Whilst examining a sample of the lens, Mr. Zentmayer remarked, "Why did the inventor adopt an achromatic combination, when the same or even better results could have been obtained by the combination of two simple meniscus lenses? Recognizing the force of the query, Mr. Sellers requested Mr. Zentmayer to experiment with a double lens. This having been successfully accomplished, he urged him to apply for a patent, which was reluctantly agreed to and done after the most earnest solicitation.

The introduction of this lens engendered a most spirited controversy as to question of the theory in optics involved in its construction. Prof. Henry Morton, Dallmeyer and other well-known authoritative scientists and experts, both here and abroad, took part in this discussion. Mr. Zentmayer's personal appearance in the matter, which showed itself in a short article entitled "Refraction without Dispersion and some Reflection," in the August, 1867, number of the *Philadelphia Photographer*, proved at once in a most forcible and logical manner that the writer was a consummate master in the field of theoretical and applied optics; a paper that immediately established him as America's foremost optician.

One monograph, as further illustrating the remarkable clearness, ease of expression and fullness of comprehension with which he surrounded one of the most abstruse and most readily misunderstood of the theoretical and applied sciences—optics—is his illustrated brochure of twenty-three pages entitled "A Lecture on Lenses." This, which appeared in the May and June, 1876, numbers of the *Journal of the Franklin Institute*, is even now authoritatively recognized as one of the best, the most concise, and the clearest expositions of the subject that has ever been presented to the public.

Engaged as the official maker of the microscopes used in the hospitals of the United States Army; appointed a member of the Iowa Total Eclipse Exhibition in 1869, to the success of which he contributed largely by the device of some of the most delicate of the photographic machinery; a member of the Judge of Awards in the 1874 Fair of the Franklin Institute, the International Centennial Exhibition in 1876, and the Electrical Exhibition in 1885; a life-member of the German Hospital, and a member of the American Philosophical Society, the Academy of the Natural Sciences of Philadelphia, both the American and British Associations for the Advancement of Science, the Franklin Institute of Philadelphia, both

the American Society and the New York Society of Microscopists, the Biological and Microscopical Society of Philadelphia, the Philadelphia Photographic Society, the Young Männerchor, the Turn-Gemeinde, the Künstlerverein, we can well see that not only was his public work of the most varied character, the most useful to both his city and his country, and of the most value to science, but that his associations were the widest, the most congenial, and the most elevating in character.

Amongst his intimate German friends, his literary knowledge of the authors in his native tongue was well known. Ever a lover of Goethe and the cynical wit of a Heine; deep in the matchless guessings and wonderful intuition of a Von Humboldt, he lived with them the ideal life that always remain ideal to a kindred Teutonic mind.

How much we must praise him when in spite of the fact that he acquired our language (one of the most difficult) after he had gained his majority, he read and reread that never-to-be-repeated series of studies of the human passions by William Shakespeare, enjoyed the young passionate and conscienceless words and thoughts of Byron, laughed and sighed with Burns, walked with Dickens, and followed our own poet laureate, Longfellow.

These associations, as well as those higher correlated ones of music, painting and sculpture, formed both in public life by active membership in various local literary and physical-culture societies, and in the privacy of home with its small, though well-selected collection of works of arts, to which he brought many of his literary and artistic friends, evidence not only his exceptional taste in these the pleasures of higher mental life, but exhibit his acumen and critical judgment in their enjoyment.

After a lingering and extremely sad illness he died in Philadelphia, Pa., on the 28th day of March, 1888.

How can we better do in this meagre sketch than repeat the words of the resolution passed by those nearest and dearest to him in his daily work, his workmen for the last quarter of a century.

Resolved, That we give public expression to our regard for the memory of the late Joseph Zentmayer, as a man whose benevolence, good nature, modesty and friendly disposition endeared him to us through many years of social intimacy; as a workman whose originality, thorough practical skill and energy has made his name known throughout the scientific world; as an employer whose sense of justice and equity equaled his superior natural abilities; as a friend upon whose judicious counsel we could always rely; and that, in our memories, he shall ever be an example of what constitutes a good man."

Justum et tenacem propositi virum.

VOLUMES AND DATES OF PROCEEDINGS AND
TRANSACTIONS OF THE AMERICAN
PHILOSOPHICAL SOCIETY.

PROCEEDINGS.

VOLS.	YEARS.	NUMBERS.
I.	1838-40.	1, 2, 3, 4, 5, 6, 7, 8, 9, 10, 11, 12, 13, 14.
II.	1841-43.	15, 16, 17, 18, 19, 20, 21, 22, 23, 24, 25, 26.
III.	1843.	27.
IV.	1843-47.	28, 29, 30, 31, 32, 33, 34, 35, 36, 37, 38, 39.
V.	1848-53.	40, 41, 42, 43, 44, 45, 46, 47, 48, 49, 50.
VI.	1854-58.	51, 52, 53, 54, 55, 56, 57, 58, 59, 60.
VII.	1856-60.	61, 62, 63, 64.
VIII.	1861.	65, 66.
IX.	1862-64.	67, 68, 69, 70, 71, 72.
X.	1865-68.	73, 74, 75, 76, 77, 78, 79, 80.
XI.	1869-70.	81, 82, 83, 84, 85.
XII.	1871-72.	86, 87, 88, 89.
XIII.	1873.	90, 91.
XIV.	1875.	92, 93, 94, 95.
XV.	1876.	96.
XVI.	1876-77.	97, 98, 99.
XVII.	1877-78.	100, 101.
XXVIII.	1878-80.	102, 103, 104, 105, 106.
XIX.	1880-81.	107, 108, 109.
XX.	1882-83.	110, 111, 112, 113.
XXI.	1883-84.	114, 115, 116.
XXII.	1885.	117, 118, 119, 120. (119 is Part iii, of Vol. xxii; the early proceedings 1744-1833.)
XXIII.	1886.	121, 122, 123, 124.
XXIV.	1887.	125, 126.
XXV.	1888.	127, 128.
XXVI.	1889.	129, 130.
XXVII.	1889.	131.
XXVIII.	1890.	132, 133, 134.
XXIX.	1891.	135, 136.
XXX.	1892.	137, 138, 139.
XXXI.	1893.	140, 141, 142.
XXXII.	1894.	143, Sesquicentennial Anniversary Volume.

TRANSACTIONS.

[*Old Series.*]

VOLS.	YEARS.	VOLS.	YEARS.	VOLS.	YEARS.
I.	1759.	III.	1793.	V.	1802.
II.	1786.	IV.	1799.	VI.	1809.

[*New Series.*]

VOLS.	YEARS.	VOLS.	YEARS.	VOLS.	YEARS.
I.	1818.	VII.	1841.	XIII.	1869.
II.	1825.	VIII.	1843.	XIV.	1871.
III.	1830.	IX.	1846.	XV.	1881.
IV.	1834.	X.	1853.	XVI.	1890.
V.	1837.	XI.	1860.	XVII.	1893.
VI.	1839.	XII.	1863.	XVIII.	

INDEX TO VOL. XXXI.

Meetings Held.

	<i>Page.</i>		<i>Page.</i>
1893, January 6	1	1893, May 19	228
January 20	5	September 1	233
February 3	9	September 15	242
February 17	14	October 6	247
March 3	128	October 20	252
March 17	130	November 3	348
April 7	135	November 17	351
April 21	137	December 1	355
May 5	226	December 15	356

New Members Elected.

February 17, 1893.

No. 2210. Hippolyte Taine	Menthone, Haute Savoie, France	16
2211. Charles Schœffer	Philadelphia	16
2212. George Lincoln Goodale	Cambridge, Mass	16
2213. Robert E. Pattison	Harrisburg, Pa.	16

May 19, 1893.

No. 2211. Charles P. Daly	New York, N. Y	231
2215. Isaac H. Hall	New York, N. Y	231
2216. Isaac J. Wistar	Philadelphia	231
2217. Edward Vincent d'Invilliers	Philadelphia	231
2218. Waterman L. Hewitt	Ithaca, N. Y	231
2219. Justin Winsor	Cambridge, Mass	231
2220. William Hyde Appleton	Swarthmore, Pa	231
2221. James E. Rhoads	Bryn Mawr, Pa	231

October 20, 1893.

No. 2222. Samuel A. Green	Boston, Mass.	254
2223. John G. Morris	Baltimore, Md	251
2221. J. M. Hoppin	New Haven, Conn	254
2225. Chev. Rousseau d'Happonecourt	Vienna, Austria	254
2226. Isaac Roberts	London, England	254

Decease of Members.

Sir Richard Owen	3	C. C. Jones	242
John O. Westwood	3	Robert Cornelius	242
Eben N. Horsford	3	William H. C. Bartlett	242
Isaac C. Martindale	3	Edward Hopper	246
F. A. Genth	11	John M. Maseh	246
C. Schorlemmer	128	Furman Sheppard	349
Hippolyte Taine	132	Conrad Leemans	349
William B. Rogers	132	Karl Chev. Rousseau d'Happonecourt	352
Isaac Burk	135	Hermann August Hagen	352
Esquiron de Parieu	138	Thomas M. Cleemann	355
Thomas H. Dudley	138	Joseph D. Potts	357
Anthony J. Drexel	241	John Tyndall	357

Obituary Notices.

	<i>Page.</i>
Obituary Notice ordered—Isaac C. Martindale by Joseph T. Rothrock.	3
F. A. Genth by G. F. Barker	11
Thomas H. Dudley by William John Potts	138
John M. Maisch by Charles S. Dolley.	246
Furman Sheppard by Mr. McKean.	349, 353
Thomas M. Cleemann by Mr. Frederick Prime.	355
Joseph D. Potts	357
Obituary Notices read—William B. Rogers by Dr. Rusehenberger.	251, 254
Joseph Zentmayer by Dr. Charles A. Oliver.	357, 358

Resignations of Members.

Robert E. Thompson.	130
Joseph Allison	318

Acceptance of Membership.

Samuel G. Dixon, Philadelphia 1	Justin Winsor, Cambridge, Mass. 233
James Macfarlane, Lansdowne, Pa. 1	Waterman L. Hewitt, Ithaca, N. Y. 233
James Ellis Humphrey, Amherst, Mass. 1	James E. Rhoads, Bryn Mawr, Pa. 233
George Lincoln Goodale, Cambridge, Mass. 128	William Hyde Appleton, Swarthmore, Pa. 233
Charles Schäffer, Philadelphia. 128	Charles P. Daly, New York. 247
Robert E. Pattison, Harrisburg, Pa. 130	Samuel A. Green, Boston, Mass. 348
Isaac H. Hall, New York. 233	John G. Morris, Baltimore, Md. 348
Isaac J. Wistar, Philadelphia 233	T. M. Hoppin, New Haven, Conn. 348
Edward Vincent d'Invilliers, Philadelphia 233	

Written Communications.

	<i>Page.</i>
BACHE, R. MEADE.	
The Conservation of Osmazome in Roasting	318, 353
BAUR, G.	
Notes on the Classification and Taxonomy of the Testudinata	210, 227
BOAS, FRANZ.	
Vocabulary of the Kwakintl Language	31
BRINTON, D. G.	
The Central American Native Calendar.	251, 258
A Vocabulary of the Nanticoke Dialect	325
COPE, E. D.	
On the Genus <i>Toniopsis</i>	317
A New Genus <i>Toniopsis</i>	350
Batrachia and Reptilia of Costa Rica	353
Second Addition to the Knowledge of the Batrachia and Reptilia of Costa Rica	333, 353
COPE, ELLIOTT.	
A Description of the MSS. Journals and Field Notebooks of Lewis and Clark. 9, 17	

DOLLEY, CHARLES S.	<i>Page.</i>
On the Thyrsus of Dionysos, and the Palm Inflorescence of the Winged Figures of Assyrian Monuments	16, 109
DWIGHT, THOMAS.	
Observations on the Psos Parvus and Pyramidalia. A Study of Variation.	117, 132
GENTRY, THOMAS G.	
The Fungi of Philadelphia and Its Neighborhood	136, 251
HUBBARD, JESSE W.	
The Yolk Nucleus in Cymatogaster aggregatus.	358
LYMAN, B. S.	
The Great Mesozoic Fault in New Jersey	246, 247, 314
PACKARD, A. S.	
The Life History of Certain Moths of the Family Cochliopodidae, with Notes on their Spines and Tubercles	11, 83, 132, 139
PHILLIPS, FRANCIS C.	
Researches upon the Chemical Properties of Gases	132
RITTER, W. F. MCK.	
On a New Method of Determining the General Perturbations of the Minor Planets	124, 132
RYDER, JOHN A.	
Energy as a Factor in Organic Evolution	136, 192
On the Mechanical Genesis of the Fowl's Egg.	138, 203
SCOTT, W. B.	
On the Mammalian Fauna from the Deep River Beds of Montana	251
A Tabulation Movement of Civilized Society Westward in the Natural Order of Time.	357, 358
<i>Oral Communications.</i>	
BLODGET, MR.	
Maps showing the resources of the State of Pennsylvania for the Chicago World's Fair	231
BRINTON, D. G.	
On the meaning of the Mexican Calendar	251
Nanticoke Indian Vocabulary (requested to prepare same for publication) . . .	350
COPE, E. D.	
On the fauna of the Eurystylus and Equus beds of the Staked Plains.	11

COPE, E. D.	Page.
In regard to some stone implements occurring in Maryland, on the Potomac	229
On <i>Spermatodus pustulosus</i>	355
The results of late explorations by Mr. Henry C. Mercer	358
HAUPT, L. M.	
On the Atlantic Coast Ship Canal	349, 353, 354
PRIME, MR.	
On the present revolution taking place in iron making in the United States.	138
On the classification of ore deposits, and proposition of a new system	254
RYDER, JOHN A.	
The adaptive forms and the vortex motion of the substance of the red corpuscles of vertebrates	251
On the forms of fossil sharks, family Cladodontidæ	254

Miscellaneous.

Academy of Natural Sciences, Philadelphia, letter from in relation to the Keating-Poinsett Collection.	5, 6
Académie de Belgique, Bruxelles, circular requesting subscription to the works of Jean-Servais Stas.	128
American Historical Association, Washington, D. C., communication from.	234
Anthropological Society, Washington, D. C., circular relative to citizenship, prizes to be awarded	223
Atlantic coast ship canal, referred to Committee.	349
Reported on by Committee	353, 354
Memorial to Congress on	355, 355
American Folk Lore Society, circular announcing its annual meeting	2
Appropriations for ensuing year deferred	357
Bressa Prize, announcement of, by R. Academy of Sciences, Turin, Italy	5
Committees :	
Standing Committees	8, 9
On Michaux Legacy	7, 8
On Finance, William P. Tatham appointed in place of W. B. Rogers, deceased	254
On Publication, reported.	355
To Examine and Report upon a Paper by Francis C. Phillips	132, 136
To Examine Catalogue of Martindale Library, and to purchase any books contained therein, important to the Society.	229
To Examine and Report on W. B. Scott's Paper	251, 253
On Phillips Prize Essay, C. Stuart Patterson appointed a member of the Committee	353
To Prepare a General Index of all Transactions.	355
Coöperative Index of Transactions.	247, 251, 252
Congrès Internationale de Zoologie, circular relative to prizes to be awarded	233
Curators, communication from.	227
Report.	12
Columbia College, New York, circular from, concerning the Loubat Prize.	14
Cones, Dr. Elliott, request for further extension of time to retain the Lewis and Clark MSS	1
Letter thanking the Society for its loan of same	6
Council, Election, annual	3, 4
Minutes of, submitted.	16, 133, 229, 353
Endorses Atlantic coast ship canal.	353, 354
Crampton, Mr. C. H., presented to the chair.	228

	<i>Page.</i>
Dereum, Dr. Francis X., presented to the chair	5
Erratum, page 132, line 12 from top, should read, "President was authorized to appoint a suitable person to prepare the usual obituary"	
Number commencing the list of newly elected members should be 2214 instead of 2218	231
Forestry Commission, resolution requesting Senate and House of Representatives to vote in favor of the bill	16
Friesch Genootschap voor Geschied Oudheid en Taalkunde, Leeuwarden, Friesland, letter announcing the death of three of its members	251
Gadoline, Hon. Axel, death of	14
Goodwin, Mr. Harold, presented to the chair	1
Hodgkins' Prizes, circular relating to	137
Keating-Poinsett Collection, letter from the Curators of Academy of Natural Sciences relating to the	2, 5, 6
Letter from Department of Archaeology of the University of Pennsylvania requesting the deposit of the	13
Kokcharow, Hon. Nicholas, death of	14
Liberty Bell, prototype of, presented by Mr. F. Gutekunst	241
Librarian nominated	4
Re-elected	9
Loubat Prize, regulations concerning	14
Macfarlane, Dr., presented to the chair	9
Motions :	
To introduce electric lighting into the building	130
Mr. Fraley, in reference to the Haldeman Indian Collection	227
Dr. Morris, Curators to dispose of objects of no value	227
Dr. Morris, Nominations 1271-1274 referred to Council	355
Mr. Prime, memorial to Congress considered	354
Mr. Smyth, Nanticoke Indian Vocabulary to be prepared for publication	350
Mr. Williams, Coöperative Index of Transactions	247, 251, 252
Nanticoke Indian Vocabulary	350
Naturhistorische Verein der Preussischen Rheinlande, etc., Bonn, Prussia, invitation to celebration of its fiftieth anniversary	247
Niederrheinische Gesellschaft für Natur- und Heilkunde, Bonn, Prussia, invitation to celebration of its seventy-fifth anniversary	247
New Exchanges ordered	1, 130, 248
New Haven Colony Historical Society, invitation to dedication of new building	233
New York State Library, Albany, letter from, asking the Society to exhibit its publications at the Columbian Celebration	5
Nominations read	4, 9, 11, 16, 130, 132, 136, 138, 227, 229, 247, 251, 254, 354, 355, 357
Balloted for—Nos. 1235, 1250, 1251, 1252, 1253, 1254, 1255, 1256, 1257, 1258, 1259	16, 229
Nos. 1260, 1261, 1262, 1263, 1264	254
Nos. 1249, 1265, 1266, 1267	357
Pedessalli, Prof. D. Guiseppi, death of	14
Photographs received :	
Dr. F. A. Genth and Prof. F. A. Genth, Jr.	136
Dr. Isaac H. Hall	241
Mr. Henry C. Baird	241
Dr. Charles A. Oliver	241
Dr. F. A. Mühlenberg	241
Mr. Robert P. Field	251
Hon. Frederick Fraley	352
Dr. D. G. Brinton	352
Dr. J. C. Morris	352
Mr. William A. Ingham	352
Mr. Joseph Zentmayer	352

	<i>Page.</i>
Photographs received :	
Prof. E. Otis Kendall	352
Dr. Rueschenberger	355
Dr. Wurtz	355
Portrait of John Vaughan exhibited and deposited	4
Portrait received, Matthew Carey, and thanks returned to Mr. Henry C. Baird for same	227
Prime, Mr. Frederick, on a new gold field in W. Australia	350
Reports :	
Curators', relative to the requested loan of objects for the World's Fair Columbian Exposition	11, 12
Curators upon the collections of the Society	12
Of Treasurer presented	355
Of Publication Committee	355
Resolutions :	
Dr. Cope, exhibition of mental or physical deformities	136, 137
Mr. Du Bois, in reference to loan of articles for the Chicago Exposition	12
Dr. J. C. Morris, Atlantic coast ship canal	350
Dr. Rothrock, in reference to Forestry Commission	16
Rhoads, Dr. James E., presented to the chair	252
Royal Academy of Sciences, Turin, Italy, circular announcing its offer of the ninth Bressa Prize	5
Sesqui-Centennial Celebration, Prof. Cope requested information about the programme of	227
Schätfer, Dr. Charles, presented to the chair	356
Society's Collections, question of withdrawing the Society's Collection on deposit in other institutions	132, 133
Tomiopsis, Dr. Cope on	350
University of Missouri, request for certain numbers of the Proceedings	212
U. S. Coast and Geodetic Survey, Washington, D. C., letter requesting certain numbers of Proceedings and Transactions	233
Volumes and dates of Proceedings and Transactions	365
Wadsworth Athenæum, Hartford, invitation to attend the opening of the new Libraries and Art Galleries	1
Wistar, Mrs. Millin, presented to the Society a collection of letters to Dr. Caspar Wistar	241, 245
Thanks tendered to, for same	246
World's Columbian Exposition, Curators report relative to requested loan of objects for the	11, 12
Circular from Bureau of Education, Washington, D. C., in regard to the Educational Exhibit	14
Mr. Blodget's maps showing the resources of Pennsylvania for the	231
Wyoming Historical and Geological Society, Wilkesbarre, Pa., invitation to opening of its new building	351

LIST OF SURVIVING MEMBERS
OF THE
AMERICAN PHILOSOPHICAL SOCIETY,
HELD AT PHILADELPHIA
FOR
PROMOTING USEFUL KNOWLEDGE.

Corrected to January 5, 1894,

BY

HENRY PHILLIPS, JR.,

A Secretary of the Society.

*List of surviving Members of the American Philosophical Society,
held at Philadelphia for Promoting Useful Knowledge.*

The addresses here given so far as known are at the present time. Corrections of this list are respectfully solicited.

A name printed in *italics* indicates that the Society is uncertain as to whether such member is still living and desires information on the subject.

The Society will be happy to receive *photographs* (cabinet size preferred) of such of its members as have not already sent.

<i>Name.</i>	<i>A</i>	<i>Date of Election.</i>	<i>Present Address.</i>
1657. AEBE, CLEVELAND.	July	21, 1871,	Army Weather Bureau, Washington, D. C.
2170. ABBOTT, CHARLES C.	Dec.	20, 1889,	Bristol, Pa.
1463. ABBOT, HENRY L.	April	18, 1862,	New York city, N. Y.
1800. ÅCKERMAN, RICHARD	July	21, 1876,	Stockholm, Sweden.
1713. ACLAND, HENRY W.	Jan'y	17, 1873,	Oxford, England.
2128. ADAM, LUCIEN.	Dec.	17, 1886,	Rennes, France.
2081. ADAMS, H. B.	May	21, 1886,	Baltimore, Md.
1381. <i>Adinson, Rev. John C.</i>	July	13, 1856,	
1779. AGASSIZ, ALEXANDER	April	16, 1875,	Cambridge, Mass.
1612. AGASSIZ, ELIZABETH.	Oct.	15, 1869,	" "
2001. ALBRECHT, PAUL.	May	21, 1886,	Hamburg, Germany.
1860. ALISON, ROBERT H.	May	3, 1878,	Ardmore, Pa.
1869. ALLEN, JOEL ASAPH.	Sept.	20, 1878,	New York, N. Y.
1927. AMES, CHARLES G.	Jan'y	21, 1881,	Boston, Mass.
2051. ANDERSON, GEORGE B.	Feb'y	19, 1886,	West Point, N. Y.
1655. ANDERSON, GEORGE W.	Oct.	15, 1869,	Resemont, Pa.
2164. ANGELL, JAMES B.	Oct.	18, 1889,	Ann Arbor, Mich
1122. <i>Angolis, Pedro de.</i>	Jan'y	17, 1849,	<i>Buenos Ayres, S. A.</i>
2224. APPLETON, WILLIAM HYDE	May	19, 1863,	Swathmore, Pa.
2102. AEGYLL, DUKE OF.	May	21, 1886,	London, England.
1761. ARMSTRONG, WM. GEORGE	July	17, 1871,	Newcastle-on-Tyne, England.
1996. ASHURST, JOHN.	Jan'y	18, 1884,	Philadelphia.
2012. ASHURST, RICHARD L.	April	18, 1884,	" "

3

B

<i>Name.</i>	<i>Date of Election.</i>	<i>Present Address.</i>
1995. BACHE, R. MEADE	Jan'y 18, 1884,	Philadelphia.
1832. BACHE, THOMAS HEWSON	Feb'y 2, 1877,	"
1630. BAIRD, HENRY CAREY	Jan'y 15, 1869,	"
1991. BAIRD, HENRY M.	Jan'y 18, 1884,	Yonkers, N. Y.
2075. BAKER, WILLIAM S.	May 21, 1886,	Philadelphia.
2191. BALL, ROBERT S.	May 15, 1891,	Dublin, Ireland.
1936. BARBER, EDWIN ATLEE.	April 15, 1881,	West Chester, Pa.
1818. BARCENA, MARIANO.	Feb'y 2, 1877,	Mexico.
1741. BARKER, GEORGE F.	April 18, 1873,	Philadelphia.
2011. BARKER, WHARTON	April 18, 1884,	"
2144. BARNARD, WILLIAM T.	May 20, 1887,	Boonton, N. J.
1902. BARTHOLOW, ROBERTS	April 16, 1880,	Philadelphia.
1133. BARTLETT, W. H. C.	April 17, 1849,	Yonkers, N. Y.
2119. BASTIAN, ADOLPH	Dec. 17, 1886,	Berlin, Germany.
1968. BELL, ALEXANDER GRAHAM. . . .	July 21, 1882,	Washington.
1966. BELL, JOSEPH SNOWDEN	July 21, 1882,	Philadelphia.
1802. BELL, LOWTHIAN.	April 21, 1876,	Northallerton, England.
2149. BIDDLE, ALEXANDER	Feb'y 17, 1888,	Philadelphia.
2154. BIDDLE, ARTHUR	Dec. 21, 1888,	"
1920. BIDDLE, CADWALADER	Oct. 15, 1880,	"
1831. BIDDLE, CRAIG	Feb'y 2, 1877,	"
2134. BILLINGS, JOHN S.	Feb'y 18, 1887,	Washington, D. C.
2157. BLAIR, ANDREW A.	May 17, 1889,	Philadelphia.
1554. BLAIR, THOMAS S.	Jan'y 19, 1866,	Pittsburgh, Pa.
1669. BLAKE, WILLIAM PHIPPS	Oct. 21, 1870,	New Haven, Conn.
1790. BLASIUS, WILLIAM	Oct. 15, 1875,	Philadelphia.
1700. BLODGET, LORIN	April 19, 1872,	"
1444. BÖITTLINGK, OTTO	Jan'y 17, 1862,	Leipzig, Germany.
2047. BONWILL, W. G. A.	Oct. 16, 1885,	Philadelphia.
1126. BOYÉ, MARTIN H.	Jan'y 17, 1840,	Coopersburg, Pa.
1826. BRACKETT, CYRUS FOGG.	Feb'y 2, 1877,	Princeton, N. J.
2083. BRANNER, JOHN C.	May 21, 1886,	Palo Alto, Cal.
2195. BREZINA, ARISTIDES	May 21, 1886,	Vienna, Austria.
1636. BRINTON, DANIEL G.	April 16, 1869,	Philadelphia.
2069. BRINTON, JOHN H.	Feb'y 19, 1886,	"
1745. BRITTON, J. BLODGETT.	Oct. 17, 1873,	"
2080. BROOKS, WILLIAM KEITH	May 21, 1886,	Baltimore, Md.
1881. BROWN, ARTHUR ERWIN	April 18, 1879,	Philadelphia.
1333. BROWN-SEQUARD, E.	Jan'y 20, 1854,	Paris, France.
1614. BRUGSH, HENRI	Jan'y 15, 1869,	Berlin, Prussia.
1547. BRUSH, GEORGE J.	Jan'y 20, 1865,	New Haven, Conn.
1653. BULLOCK, CHARLES	Oct. 15, 1869,	Philadelphia.
1452. BUNSEN, ROBERT W.	Jan'y 17, 1862,	Heidelberg, Germany.
2007. BURK, JESSE Y.	Jan'y 18, 1884,	"
1938. BUTLER, WILLIAM	April 15, 1881,	West Chester, Pa.

C

1788. CAMPBELL, JOHN LYLE	July 16, 1875,	Crawfordsville, Ind.
1606. CANBY, WILLIAM MARRIATT	Oct. 16, 1868,	Wilmington, Del.
2051. CANNIZZARO, TOMMASO	Oct. 16, 1885,	Messina, Italy.
1731. CAPELLINI, GIOVANNI	April 18, 1873,	Bologna, Italy.
1796. CARLL, J. F.	Oct. 15, 1875,	Pleasantville, Pa.
2130. CARRILLO, CRESCENCIO	Dec. 17, 1886,	Merida, Yucatan.
1911. CARSON, HAMPTON L.	April 16, 1880,	Philadelphia.

<i>Name.</i>	<i>Date of Election.</i>	<i>Present Address.</i>
1707. CASSATT, ALEXANDER JOHNSON .	Oct. 15, 1872,	Philadelphia.
2147. CASTNER, SAMUEL, JR.	Dec. 16, 1887,	"
2152. CATTELL, J. MCKEEN	May 18, 1888,	New York, N. Y.
1675. CATTELL, WILLIAM C.	Jan'y 20, 1871,	Philadelphia.
1908. CHANCE, HENRY MARTYN . . .	April 16, 1880,	"
1783. CHANDLER, C. F.	April 16, 1875,	New York, N. Y.
1778. CHAPMAN, HENRY C.	April 16, 1875,	Philadelphia.
2132. CHARENCEY, COMTE HYACINTH DE	Dec. 17, 1883,	St. Maurice les Charencey France.
2111. CHILDS, GEORGE W.	Dec. 17, 1886,	Philadelphia.
2158. CLARK, CLARENCE H.	May 17, 1889,	"
1717. CLARKE, THOMAS C.	Jan'y 17, 1873,	New York, N. Y.
1983. CLAYPOLE, E. W.	Jan'y 19, 1883,	Akron, Ohio.
1876. CLOISEAUX, DES, A.	Oct. 18, 1879,	Paris, France.
1999. COHEN, J. SOLIS	Jan'y 18, 1884,	Philadelphia.
2095. COLERIDGE, LORD	Jan'y 18, 1881,	London, England.
1555. COPE, EDWARD D.	Jan'y 19, 1866,	Philadelphia.
1367. COPPÉE, HENRY	Jan'y 18, 1856,	Bethlehem, Pa.
2129. CORA, GUIDO	Dec. 17, 1886,	Turin, Italy.
1867. COUES, ELLIOTT	Sept. 20, 1878,	Washington, D. C.
1662. COX, J. D.	April 15, 1870,	Cincinnati, O.
1672. COXE, ECKLEY B.	Oct. 21, 1870,	Drifton, Pa.
2207. CRAMP, CHARLES H.	Dec. 16, 1892,	Philadelphia.
1836. CRANE, THOMAS F.	Feb'y 2, 1877,	Ithaca, N. Y.
2100. CROOKES, WILLIAM	May 21, 1886,	London, England.
2172. CRUZ, FERNANDO (of Guatemala)	Dec. 20, 1889.	
1439. CURWEN, JOHN	April 18, 1861,	Warren, Pa.

D

1567. DA COSTA, J. M.	Oct. 19, 1866,	Philadelphia.
2214. DALY, CHARLES P.	May 19, 1893,	New York, N. Y.
1354. DANA, JAMES D.	July 21, 1854,	New Haven, Conn.
1806. DANNEFELD, C. JUHLIN	April 21, 1876,	Stockholm, Sweden.
1516. DAUBRÉE, A.	July 17, 1863,	Paris, France.
1811. DAVENPORT, SAMUEL	Oct. 20, 1876,	Adelaide, S. Australia.
1557. DAVIDSON, GEORGE	Jan'y 19, 1866,	San Francisco, Cal.
1923. DAWKINS, WILLIAM B.	Oct. 15, 1880,	Manchester, England.
1468. DAWSON, JOHN W.	April 18, 1862,	Montreal, Canada.
2131. DELGADO, JUAN DE DIAS DE LA RADA Y.	Dec. 17, 1886,	Madrid, Spain.
2208. DERCUM, FRANCIS X.	Dec. 16, 1892,	Philadelphia.
2013. DICKSON, SAMUEL	April 18, 1884,	"
2208. DIXON, SAMUEL G.	Dec. 16, 1892,	"
2108. DOLLEY, CHARLES S.	Dec. 17, 1886,	"
2089. DONNER, OTTO	May 21, 1886,	Helsingfors, Finland.
1946. DOOLITTLE, C. L.	Oct. 21, 1881,	Bethlehem, Pa.
1839. DOUGLASS, JAMES, JR.	April 20, 1877,	Spuytenduyvil, N. Y.
1924. DRAPER, DANIEL	Oct. 15, 1880,	New York, N. Y.
1787. DROWN, THOMAS M.	July 16, 1875,	Boston, Mass.
1918. DU BOIS, PATTERSON	Oct. 15, 1889,	Philadelphia.
1878. DUDLEY, CHARLES BENJAMIN .	Jan'y 17, 1879,	Altoona, Pa.
2063. DUNCAN, LOUIS	Feb'y 19, 1886,	U. S. Navy.
1573. DUNNING, GEORGE F.	Jan'y 18, 1867,	Farmington, Conn.
1727. DUPONT, EDOUARD	April 18, 1873,	Brussels, Belgium.
2086. DURUY, VICTOR	May 21, 1886,	Paris, France.
1679. DUTTON, CLARENCE E.	Jan'y 20, 1871,	Washington, D. C.

E

<i>Name.</i>	<i>Date of Election.</i>	<i>Present Address.</i>
2105. EASTON, MORTON W.	Dec. 17, 1886,	Philadelphia.
1917. ECKFELDT, JACOB B.	Oct. 15, 1880,	"
1825. EDDY, HENRY T.	Feb'y 2, 1877,	Terre Haute, Ind.
1686. ELIOT, CHARLES W.	April 21, 1871,	Cambridge, Mass.
1981. EDMONS, S. F.	Jan'y 19, 1883,	Washington, D. C.
1943. EVANS, JOHN	Oct. 21, 1881,	Hemel Hempstead, Eng.

F

2180. FIELD, ROBERT PATTERSON . . .	May 16, 1890,	Philadelphia.
1901. FLINT, AUSTIN, JR.	April 16, 1880,	New York, N. Y.
1621. FLOWER, WM. HENRY.	Jan'y 15, 1869,	London, England.
1875. FOGGO, EDWARD A.	Oct. 18, 1879,	Philadelphia.
2197. FORBES, GEORGE	Oct. 16, 1891,	London, England.
1170. FRALEY, FREDERICK	July 15, 1842,	Philadelphia.
1912. FRALEY, JOSEPH C.	April 16, 1880,	"
1695. FRAZER, PERSIFOR	Jan'y 19, 1872,	"
2171. FRIEBIS, GEORGE	Dec. 20, 1889,	"
1459. FROUDE, J. A.	Jan'y 17, 1862,	London, England.
2179. FULLERTON, GEORGE S.	May 16, 1890,	Philadelphia.
1739. FULTON, JOHN.	April 18, 1873,	Johnstown, Pa.
1914. FURNESS, HORACE HOWARD . . .	April 16, 1880,	Philadelphia.
1130. FURNESS, WILLIAM H.	April 17, 1840,	"

G

1988. GARRETT, PHILIP C	April 20, 1883,	Philadelphia.
2079. GATES, M. E.	May 21, 1886,	Auberst, Mass.
1025. GATSCHE, ALBERT S.	Oct. 17, 1884,	Washington, D. C.
1897. GEIKIE, ARCHIBALD	Jan'y 16, 1880,	London, England.
1803. GEIKIE, JAMES.	April 21, 1876,	Edinburgh, Scotland.
2067. GENTH, F. A., JR.	Feb'y 19, 1886,	Philadelphia, Pa.
1355. GIBBS, OLIVER WOLCOTT.	July 21, 1854,	Cambridge, Mass.
1587. GILL, THEODORE NICHOLAS . . .	July 19, 1867,	Washington, D. C.
1800. GILMAN, DANIEL C.	April 21, 1876,	Baltimore, Md.
1940. <i>Giraldes, J. P. C. Cassado de.</i> . .	July 20, 1827.	
1950. GLADSTONE, WM. EWART	Oct. 21, 1881,	London, England.
2212. GOODALE, GEORGE LINCOLN . . .	Feb. 17, 1893,	Cambridge, Mass.
2162. GOODE, G. BROWN	Oct. 18, 1889,	Washington, D. C.
1835. GOODELL, WILLIAM	Feb'y 2, 1877,	Philadelphia.
1680. GOODFELLOW, EDWARD.	Jan'y 20, 1871,	Washington, D. C.
2203. GOODWIN, HAROLD	May 20, 1892,	Philadelphia.
1271. GOULD, BEN. APTHORP	Jan'y 17, 1851,	Cambridge, Mass.
1851. GRAY, ELISHA.	Jan'y 18, 1878,	Chicago, Ill.
1605. GREEN, TRAILL	Oct. 16, 1868,	Easton, Pa.
1504. GREEN, WILLIAM HENRY	April 17, 1863,	Princeton, N. J.
1880. GREENE, WILLIAM H.	April 18, 1879,	Philadelphia.
2155. GREGORIO, IL MARCHESE ANTONIO DE	Dec. 21, 1888,	Palermo, Italy.
2159. GREGORY, HENRY D.	May 17, 1889,	Philadelphia.
2188. GREGORY, CASPAR RÉNÉ.	May 15, 1891,	Leipzig.
1229. <i>Grimaldi, Ceva</i>	Oct. 16, 1846,	<i>Naples, Italy.</i>
1939. GRISCOM, WM. WOODNUTT	April 15, 1881,	Haverford, Pa.
1815. GROTE, AUGUSTUS RADCLIFFE . . .	Oct. 20, 1876.	
2090. GUBERNATIS, ANGELO DE	May 21, 1886,	Florence, Italy.
1438. <i>Guyangos, Pascual de.</i>	April 19, 1861,	<i>Madrid, Spain.</i>

6

H

<i>Name.</i>	<i>Date of Election.</i>	<i>Present Address.</i>
2054. HAECKEL, ERNEST.	Oct. 16, 1885,	Jena, Prussia.
1658. HALE, EDW. EVERETT.	Jan'y 21, 1870,	Roxbury, Mass.
1709. HALE, HORATIO.	Oct. 18, 1872,	Clinton, Canada.
1853. HALL, ASAPH.	Jan'y 18, 1878,	Washington, D. C.
1795. HALL, CHARLES EDWARD.	Oct. 15, 1875,	Westport, N. Y.
2219. HALL, ISAAC H.	May 19, 1893,	New York, N. Y.
1356. HALL, JAMES.	July 21, 1854,	Albany, N. Y.
2027. HALL, LYMAN B.	Jan'y 16, 1885,	Haverford, Pa.
1412. HAMMOND, WILLIAM A.	Oct. 21, 1859,	New York, N. Y.
2194. HAMY, E. T.	May 15, 1891,	Paris, France.
1337. HARDING, GEORGE.	Jan'y 20, 1854,	Philadelphia.
2136. HARRIS, JOSEPH S.	May 20, 1887,	"
1827. HART, JAMES MORGAN.	Feb'y 2, 1877,	Ithaca, N. Y.
1510. HARTSHORNE, HENRY.	July 17, 1863,	Philadelphia.
1764. HAUER, FRANZ RITTER VON.	Oct. 16, 1874,	Vienna, Austria.
1681. HAUPT, HERMANN.	April 21, 1871,	St. Paul, Minn.
1862. HAUPT, LEWIS M.	May 3, 1878,	Philadelphia.
2082. HAYES, R. SOMERS.	May 21, 1886,	New York, N. Y.
2071. HAYS, J. MINIS.	Feb'y 19, 1886,	Philadelphia.
2165. HAZLEHURST, HENRY.	Oct. 18, 1889,	"
1985. HEILPRIN, ANGELO.	April 20, 1883,	"
1734. HELMHOLTZ, HEINRICH.	April 18, 1873,	Berlin, Prussia.
2222. HEWITT, WATERMAN L.	May 19, 1893,	Ithaca, N. Y.
1963. HILL, HAMILTON ANDREWS.	April 21, 1882,	Boston, Mass.
2110. HILPRECHT, HERMANN V.	Dec. 17, 1886,	Philadelphia.
1768. HIMES, CHARLES FRANCIS.	Oct. 16, 1874,	Carlisle, Pa.
1663. HITCHCOCK, CHARLES HENRY.	April 15, 1870,	Hanover, N. H.
2160. HOFFMAN, WALTER J.	Oct. 18, 1889,	Washington, D. C.
2068. HOLLAND, JAMES W.	Feb'y 19, 1886,	Philadelphia.
1898. HOLMES, OLIVER WENDELL.	Jan'y 16, 1880,	Boston, Mass.
1624. HOOKER, JOSEPH D.	Jan'y 15, 1869,	London, England.
1607. HORN, GEORGE HENRY.	Oct. 16, 1868,	Philadelphia.
2070. HORNER, INMAN.	Feb'y 19, 1886,	"
1941. HOTCHKISS, JEDEDIAH.	Oct. 21, 1881,	Staunton, Va.
1696. HOUGH, GEORGE W.	Jan'y 19, 1872,	Evanston, Ill.
1698. HOUSTON, EDWIN J.	Jan'y 19, 1872,	Philadelphia.
2143. HOUSTON, HENRY H.	May 20, 1887,	"
2084. HOVELACQUE, ABEL.	May 21, 1886,	Paris, France.
1843. HUMPHREY, H. C.	July 20, 1877,	"
2211. HUMPHREY, JAMES ELLIS.	Dec. 16, 1892,	Amherst, Mass.
1623. HUXLEY, THOMAS HENRY.	Jan'y 15, 1869,	London, England.
1426. HYRTL, JOSEPH.	July 20, 1860,	Vienna, Austria.

I

2052. IM THURN, EVERARD F.	Oct. 16, 1885,	Georgetown, British Guiana.
2221. D'INVILLIERS, EDWARD VINCENT.	May 19, 1893,	Philadelphia.
1773. INGHAM, WM. ARMSTRONG.	April 16, 1875,	"

J

2010. JAMES, EDMUND J.	April 18, 1884,	Philadelphia.
1933. JANNET, CLAUDIO.	April 15, 1881,	Paris, France.
2049. JAYNE, HORACE.	Oct. 16, 1885,	Philadelphia.
1954. JEFFERIS, WILLIAM W.	Jan'y 20, 1882,	"
2017. JORDAN, FRANCIS, JR.	April 18, 1884,	"

K

<i>Name.</i>	<i>Date of Election.</i>	<i>Present Address.</i>
1989. KANE, ELISHA KENT.	April 20, 1883,	Kane, Pa.
2169. KEANE, JOHN J.	Dec. 20, 1889,	Washington, D. C.
1348. KEATING, WILLIAM V.	April 21, 1854,	Philadelphia.
2021. KEEN, WILLIAM W.	July 18, 1884,	"
1723. KELVIN, LORD (WM. THOMSON). .	April 18, 1873,	London, England.
2118. KIEPERT, HENRI.	Dec. 17, 1886,	Berlin, Prussia.
1161. KENDALL, E. OTIS.	Jan'y 21, 1842,	Philadelphia.
1708. KING, CLARENCE.	Oct. 18, 1872,	New York, N. Y.
1284. KIRKWOOD, DANIEL.	April 18, 1851,	Riverside, Cal.
1767. KÖNIG, GEORGE A.	Oct. 16, 1874,	Houghton, Mich.
2167. KRAUSS, FRIEDERICH S.	Dec. 20, 1889,	Vienna, Austria.

L

1694. LAMBERT, GUILLAUME.	Jan'y 19, 1872,	Louvain, Belgium.
1858. LANDRETH, BURNET.	Jan'y 18, 1878,	Bristol, Pa.
1781. LANGLEY, SAMUEL P.	April 16, 1875,	Washington, D. C.
1721. LA ROCHE, C. PERCY.	Jan'y 17, 1873,	Rome, Italy.
1711. LAUTH, FRANZ JOSEPH.	Oct. 18, 1872,	Munich, Bavaria.
1974. LAWES, JOHN BENNETT.	Jan'y 19, 1883,	Rothamstead, Herts, Eng.
1595. LEA, HENRY CHARLES.	Oct. 18, 1867,	Philadelphia.
1737. LE CONTE, JOSEPH.	April 18, 1873,	Berkeley, Cal.
1986. LEHMAN, AMBROSE E.	April 20, 1883,	Philadelphia.
2182. LELAND, CHARLES G.	May 16, 1890,	London, Eng.
2174. LE MOINE, J. M.	Dec. 20, 1889,	Quebec, Canada.
1934. LE ROY-BEAULIEU, PAUL.	April 15, 1881,	Paris, France.
1382. LESLEY, J. PETER.	July 13, 1856,	Philadelphia.
1376. LETCHWORTH, ALBERT S.	Jan'y 18, 1856,	"
2085. LEVASSEUR, EMILE.	May 21, 1886,	Paris, France.
1415. LEWIS, FRANCIS W.	Jan'y 20, 1860,	Philadelphia.
1383. LEYBURN, JOHN.	July 13, 1856,	Baltimore, Md.
1756. LOCKYER, JOSEPH NORMAN. . . .	April 17, 1874,	London, England.
2202. LOW, SETH.	Feb. 19, 1892,	New York, N. Y.
1872. LONGSTRETH, MORRIS.	Sept. 20, 1878,	Philadelphia.
2019. LUBBOCK, JOHN.	July 18, 1884,	London, England.
2003. LUDLOW, WILLIAM.	Jan'y 18, 1884,	U. S. A.
1629. LYMAN, BENJAMIN SMITH.	Jan'y 15, 1869,	Philadelphia.

M

2107. MACALISTER, JAMES.	Dec. 17, 1886,	Philadelphia.
2209. MACFARLANE, JOHN M.	Dec. 16, 1892,	Lansdowne, Pa.
1970. MALLERY, GARRICK, JR.	Oct. 20, 1882,	Washington, D. C.
2042. MALLEY, JOHN WM.	Jan'y 16, 1885,	University of Virginia, Va
1847. MANSFIELD, JOHN.	Jan'y 18, 1878,	Cannelton, Pa.
1857. MARCH, FRANCIS ANDREW.	Jan'y 18, 1878,	Easton, Pa.
1861. MARKS, WILLIAM D.	May 3, 1878,	Philadelphia.
1604. MARSH, OTHNIEL C.	Oct. 16, 1868,	New Haven, Conn.
2078. MARSHALL, IRA.	May 21, 1886,	Philadelphia.
1018. <i>Martínez, Juan José</i>	April 20, 1832,	<i>Spain.</i>
2184. MASCART, E.	Dec. 19, 1890,	Paris, France.
1572. MASON, ANDREW.	Jan'y 18, 1867,	New York, N. Y.
2196. MASPERO, GASTON.	May 15, 1891,	Paris, France.
1654. MAYER, ALFRED M.	Oct. 15, 1869,	Hoboken, N. J.
1928. MCCAULEY, EDWARD Y.	Jan'y 21, 1881,	Philadelphia.
1685. MCCOSH, JAMES.	April 21, 1871,	

<i>Name.</i>	<i>Date of Election.</i>	<i>Present Address.</i>
1888. MCCREATH, ANDREW S.	July 18, 1879,	Harrisburg, Pa.
1821. MCKEAN, WILLIAM V.	Feb'y 2, 1877,	Philadelphia.
2004. MCMASTER, JOHN BACH	Jan'y 18, 1884,	"
1677. MEEHAN, THOMAS	Jan'y 20, 1871,	"
1903. MERRICK, JOHN VAUGHAN	April 16, 1880,	"
1947. MERRIMAN, MANSFIELD	Oct. 21, 1881,	Bethlehem, Pa.
1744. MESSCHERT, MATHEW HUIZINGA.	Oct. 17, 1873,	Douglassville, Pa.
2142. MICHAEL, HELEN ABBOTT.	May 20, 1887,	Philadelphia.
2175. MITCHELL, JAMES T.	Feb'y 21, 1890,	"
1461. MITCHELL, S. WEIR	Jan'y 17, 1862,	"
2114. MONIER-WILLIAMS, MONIER	Dec. 17, 1886,	London, England.
1791. MOORE, GIDEON E.	Oct. 15, 1875,	New York, N. Y.
2029. MOORE, JAMES W.	Jan'y 16, 1885,	Easton, Pa.
1841. MOREHOUSE, GEORGE R.	April 20, 1877,	Philadelphia.
1054. <i>Morelli.</i>	Jan'y 15, 1836,	<i>Naples, Italy.</i>
1976. MORRIS, J. CHESTON.	Jan'y 19, 1883,	Philadelphia.
1577. MORTON, HENRY	Jan'y 18, 1867,	Hoboken, N. J.
2121. MUCH, MATTHEUS.	Dec. 17, 1886,	Vienna, Austria.
1866. MUILLENBERG, F. A.	Sept. 20, 1878,	Reading, Pa.
2120. MUELLER, FRIEDERICH	Dec. 17, 1886,	Vienna, Austria.
1486. MUELLER, F. MAX.	Jan'y 16, 1863,	Oxford, England.
2192. MUNROE, CHARLES E.	May 15, 1891,	Washington, D. C.
1892. MUONI, DAMIANO	Jan'y 16, 1880,	Milan, Italy.
2062. MURDOCK, J. B.	Feb'y 19, 1886,	U. S. Navy.
1937. MURRAY, JAMES A. II.	April 15, 1881,	Oxford, England.

N

2087. NADAILLAC, MARQUIS DE.	May 21, 1886,	Paris, France.
1852. NEWCOMB, SIMON	Jan'y 18, 1878,	Washington, D. C.
1582. NEWTON, HUBERT ANSON	April 19, 1869,	New Haven, Conn.
1703. NICHOLS, STARR HOYT	July 19, 1872,	New York, N. Y.
2060. NIKITIN, SERGE	Feb'y 19, 1866,	St. Petersburg, Russia.
1805. NORDENSKIÖLD, ADOLF ERIC	April 21, 1876,	Stockholm, Sweden.
1712. NORRIS, ISAAC.	Oct. 18, 1872,	Philadelphia.
2106. NORRIS, WILLIAM F.	Dec. 17, 1886,	"
2046. NORTH, EDWARD.	Oct. 16, 1885,	Clinton, N. Y.

O

2072. OLIVER, CHARLES A.	Feb'y 19, 1886,	Philadelphia.
1715. OLIVER, JAMES E.	Jan'y 17, 1873,	Ithaca, N. Y.
2195. OPPERT, JULES.	May 15, 1891,	Paris, France.
2135. OSBORN, HENRY F.	Feb'y 18, 1887,	Princeton, N. J.
1581. OSBORN, HENRY S.	Jan'y 18, 1867,	Oxford, O.
2039. OSLER, WILLIAM	Jan'y 16, 1885,	Baltimore, Md.
1801. OWEN, P. CUNLIFFE	April 21, 1876,	London, England.

P

1868. PACKARD, A. S., JR.	Sept. 20, 1878,	Providence, R. I.
1578. PACKARD, JOHN H.	Jan'y 18, 1867,	Philadelphia.
1331. PAGET, JAMES	Jan'y 20, 1854,	London, England.
1984. PANCOAST, WILLIAM HENRY	Jan'y 19, 1883,	Philadelphia.
2036. PARVIN, THEOPHILUS	Jan'y 16, 1885,	"
2056. PASTEUR, LOUIS	Oct. 16, 1885,	Paris, France.
2035. PATTERSON, C. STUART.	Jan'y 16, 1885,	Philadelphia.
1282. PATTERSON, ROBERT	April 18, 1851,	"

<i>Name.</i>	<i>Date of Election.</i>	<i>Present Address.</i>
1320. PATTERSON, THOMAS L.	April 15, 1853,	Cumberland, Md.
2213. PATTISON, ROBERT E.	Feb. 17, 1893,	Harrisburg, Pa.
1772. PEARSE, JOHN B.	Jan'y 15, 1875,	Boston, Mass.
1859. PEIRCE, C. NEWLIN	May 3, 1878,	Philadelphia.
1722. PEMBERTON, HENRY	Jan'y 17, 1873,	"
2101. PEÑAFIEL, ANTONIO	May 21, 1886,	Mexico.
2073. PENNYPACKER, SAMUEL W.	May 21, 1886,	Philadelphia.
1518. PENROSE, R. A. F.	July 17, 1863,	"
2059. PEPPER, EDWARD	Feb'y 19, 1886,	Paris.
1666. PEPPER, WILLIAM	July 15, 1870,	Philadelphia.
951. <i>Percira, José Maria Dantes.</i>	April 18, 1828,	<i>Lisbon, Portugal.</i>
1705. PETER, ROBERT	July 19, 1872,	Lexington, Ky.
1824. PHILLIPS, HENRY, JR.	Feb'y 2, 1877,	Philadelphia.
1760. PLATT, FRANKLIN	July 17, 1874,	"
2127. PLATZMAN, JULIUS	Dec. 17, 1886,	Leipzig, Germany.
2053. POMIALOWSKY, JOHN	Oct. 16, 1885,	St. Petersburg, Russia.
1539. PORTER, THOMAS CONRAD	Oct. 21, 1864,	Easton, Pa.
2044. POTTS, WILLIAM JOHN	Oct. 16, 1885,	Camden, N. J.
2097. POSTGATE, J. P.	May 21, 1886,	Cambridge, England.
2161. POWELL, J. W.	Oct. 18, 1889,	Washington, D. C.
1619. PRESTWICH, JOSEPH	Jan'y 15, 1869,	Shoreham, England.
1592. PRICE, J. SERGEANT	Oct. 18, 1867,	Philadelphia.
1780. PRIME, FREDERICK, JR.	April 16, 1875,	"
2088. PULZSKY, FRANCIS	May 21, 1886,	Buda-Pesth, Hungary.
1758. PUMPELLY, RAPHAEL	April 17, 1874,	Newport, R. I.

Q

973. <i>Quadrada, Francisco de Paolo</i>	Oct. 16, 1829,	<i>Madrid, Spain.</i>
1143. <i>Quaranta, Barnardo.</i>	Jan'y 15, 1841,	<i>Naples, Italy.</i>

R

1736. RAND, THEODORE D.	April 18, 1873,	Philadelphia.
1849. RANDALL, F. A.	Jan'y 18, 1878,	Warren, Pa.
1644. RAWLINSON, GEORGE.	Oct. 15, 1869,	Oxford, England.
1765. RAWSON, RAWSON W.	Oct. 16, 1874,	London, "
2099. RAYLEIGH, LORD	May 21, 1886,	Essex, England.
1784. RAYMOND, ROSSITTER W.	April 16, 1875,	New York, N. Y.
1585. RAYNOLDS, WILLIAM F.	April 19, 1867,	Detroit, Mich.
1591. READ, JOHN MEREDITH	July 19, 1867,	"
2077. REED, HENRY	May 21, 1886,	Philadelphia.
1889. REMSEN, IRA	July 18, 1879,	Baltimore, Md.
1918. RENARD, A.	Oct. 21, 1881,	Brussels, Belgium.
1343. RENARD, CHARLES	Jan'y 20, 1854,	Moscow, Russia.
1890. RENEVIER, E.	July 18, 1879,	Lausanne, Switzerland.
1816. REULEAUX, F.	Feb'y 2, 1877,	Berlin, Prussia.
2122. RÉVILLE, ALBERT	Dec. 17, 1886,	Paris, France.
2225. RHOADS, JAMES E.	May 19, 1893,	Bryn Mawr, Pa.
1500. RICHARDSON, BEN. WARD	April 17, 1863,	London, England.
1808. RILEY, CHARLES V.	April 21, 1876,	Washington, D. C.
1957. ROBINS, JAMES W.	April 21, 1882,	Philadelphia.
1390. ROGERS, FAIRMAN.	Jan'y 16, 1857,	Newport, R. I.
2177. ROGERS, ROBERT W.	Feb'y 21, 1890,	Madison, N. J.
1462. RÖHRIG, F. L. O.	April 18, 1862,	Los Angeles, Cal.
2050. ROLLETT, HERMANN.	Oct. 16, 1885,	Vienna, Austria.
1907. ROOD, OGDEN N.	April 16, 1880,	New York, N. Y.

<i>Name.</i>	<i>Date of Election.</i>	<i>Present Address.</i>
1964. ROSNY, DE, LÉON	July 21, 1882,	Paris, France.
1732. ROSSI, GIOVANNI BATTISTA	April 18, 1873,	Rome, Italy.
2198. ROSENGARTEN, JOSEPH G.	Oct. 16, 1891,	Philadelphia.
1718. ROTHERMEL, PETER F.	Jan'y 17, 1873,	Limerick P. O., Pa.
1838. ROTHROCK, JOSEPH T.	April 20, 1877,	Philadelphia.
1264. RUSCHENBERGER, W. S. W.	Oct. 19, 1849,	"
1620. RUTIMEYER, CARL L.	Jan'y 15, 1869,	Basel, Switzerland.
2109. RYDER, JOHN A.	Dec. 17, 1886,	Philadelphia.

S

1766. SADTLER, SAMUEL PHILIP	Oct. 16, 1874,	Philadelphia.
2148. SAJOUS, CHARLES E.	Feb'y 17, 1888,	Paris, France.
1563. SANDBERGER, FRIDOLIN	April 20, 1896,	Würtzburg, Bavaria.
1958. SARGENT, CHARLES SPRAGUE	April 21, 1882,	Brookline, Mass.
1730. SAUSSURE, HENRI DE.	April 18, 1873,	Geneva, Switzerland.
2211. SCHÄFFER, CHARLES	Feb'y 17, 1893,	Philadelphia.
1498. SCHOTT, CHARLES ANTHONY	April 17, 1863,	Washington, D. C.
1864. SCHURZ, CARL	Sept. 20, 1878,	
1725. SCLATER, PHILLIP LUTLEY	April 18, 1873,	London, England.
1919. SCOTT, LEWIS A.	Oct. 15, 1880,	Philadelphia.
2112. SCOTT, W. B.	Dec. 17, 1886,	Princeton, N. J.
1870. SCUDDER, SAMUEL HUBBARD.	Sept. 20, 1878,	Cambridge, Mass.
1883. SEILER, CARL	April 18, 1879,	Philadelphia.
1704. SELLERS, COLEMAN	July 19, 1872,	"
1533. SELLERS, WILLIAM	April 15, 1864,	"
1770. SELWYN, ALFRED R. C.	Oct. 16, 1874,	Montreal, Canada.
1728. SELYS, DE, LONGCHAMPS.	April 18, 1873,	Liège, Belgium.
2057. SERGI, GIUSEPPE	Oct. 16, 1885,	Rome, Italy.
1965. SÈVE DE BAR, EDOUARD	July 21, 1882,	Ramsgate, England.
2076. SHARP, BENJAMIN.	May 21, 1886,	Philadelphia.
1944. SHARPLES, PHILIP PRICE	Oct. 21, 1881,	West Chester, Pa.
1960. SHARPLES, STEPHEN PASCHALL.	April 21, 1882,	Boston, Mass.
2002. SHARPLESS, ISAAC	Jan'y 18, 1884,	Haverford, Pa.
1797. SHERWOOD, ANDREW	Oct. 15, 1875,	Mansfield, Pa.
1822. SHIELDS, CHARLES W.	Feb'y 2, 1877,	Princeton, N. J.
1532. <i>Shinz, Carl.</i>	April 15, 1864,	<i>Strasburg, Germany. (?)</i>
2146. SMITH, EDGAR F.	Oct. 21, 1887,	Philadelphia.
1544. SMITH, GOLDWIN	Jan'y 20, 1865,	
1789. SMITH, STEPHEN	Oct. 15, 1875,	New York, N. Y.
2141. SMYTH, ALBERT H.	May 20, 1887,	Philadelphia.
1742. SNOWDEN, A. LOUDON	Oct. 17, 1873,	"
2009. SNYDER, MONROE B.	Jan'y 18, 1884,	"
2189. SPANGLER, HENRY W.	May 15, 1891,	"
1720. SPOFFORD, A. R.	Jan'y 17, 1873,	Washington, D. C.
1949. STALLO, JOHN B.	Oct. 21, 1881,	Cincinnati, O.
1446. STEENSTRUP, J. J. S.	Jan'y 17, 1862,	Copenhagen, Denmark.
1990. STEVENS, WALTER LECONTE	Jan'y 18, 1884,	Troy, N. Y.
1840. STEVENSON, JOHN JAMES.	April 20, 1877,	New York, N. Y.
2168. STOKES, GEORGE G.	Dec. 20, 1889,	London, England.
1834. STRAWBRIDGE, GEORGE	Feb'y 2, 1877,	Philadelphia.
1559. STRONG, WILLIAM	Jan'y 19, 1866,	Washington, D. C.
1820. STUART, GEORGE.	Feb'y 2, 1877,	Philadelphia.
2193. STUBBS, WILLIAM	May 15, 1891,	Oxford, England.
2094. SUESS, EDWARD	May 21, 1886,	Vienna, Austria.
2023. SYLE, E. W.	July 18, 1884,	Philadelphia.

<i>Name.</i>	<i>Date of Election.</i>	<i>Present Address.</i>
1841. SYLVESTER, J. J.	July 20, 1877,	Oxford, England.
2092. SZOMBATHY, JOSEF.	May 21, 1886,	Vienna, Austria.

T

1786. TATHAM, WILLIAM P.	April 16, 1875,	Philadelphia.
1846. TAYLOR, WILLIAM B.	Oct. 19, 1877,	Washington, D. C.
2098. TEMPLE, RICHARD CARNAC	May 21, 1886,	Upper Burma, India.
2096. THOMAS, ALLEN C.	Jan'y 18, 1881,	Haverford, Pa.
1897. THOMSON, ELIHU	April 21, 1876,	Swampscott, Mass.
1993. THOMPSON, HEBER S.	Jan'y 18, 1884,	Pottsville, Pa.
1726. THOMPSON, HENRY.	April 18, 1873,	London, England.
1754. THOMSON, FRANK	April 17, 1874,	Philadelphia.
1723. THOMSON, WILLIAM (see LORD KELVIN)	April 18, 1873,	London, England.
1909. THOMSON, WILLIAM	April 16, 1880,	Philadelphia.
1530. THURY, A.	April 15, 1861,	Geneva, Switzerland.
1688. TILGHMAN, BENJAMIN C.	July 21, 1871,	Philadelphia.
1233. TILGHMAN, RICHARD A.	April 16, 1847,	"
1657. TILGHMAN, WILLIAM M.	Jan'y 21, 1870,	"
2176. TIMMINS, SAMUEL	Feb. 21, 1890,	Arley, near Coventry, Eng.
2123. TOPINARD, PAUL	Dec. 17, 1886,	Paris, France.
2065. TOPPAN, ROBERT NOXON.	Feb'y 19, 1886,	Cambridge, Mass.
1597. TOWNSEND, JOSEPH B.	Jan'y 17, 1868,	Philadelphia.
1955. TOWNSEND, WASHINGTON	Jan'y 20, 1882,	West Chester, Pa.
1691. TROWBRIDGE, WILLIAM P.	Jan'y 19, 1872,	New York, N. Y.
2024. TRUMBULL, HENRY CLAY	July 18, 1884,	Philadelphia.
1973. TSCHERMAK, GUSTAF	Oct. 20, 1882,	Vienna, Austria.
1983. TURRETTINI, THEODORE.	Dec. 19, 1890,	Geneva, Switzerland.
2166. TUTTLE, DAVID K.	Oct. 18, 1889,	Philadelphia.
2163. TYLER, LYON G.	Oct. 18, 1889,	Williamsburg, Va.
1529. TURNER, PETER	April 15, 1864,	Leoben, Austria.
2138. TYSON, JAMES	May 20, 1887,	Philadelphia.

U

2185. UNWIN, WILLIAM C.	Dec. 19, 1890,	London, England.
---------------------------------	----------------	------------------

V

2000. VAUX, RICHARD.	Jan'y 18, 1881,	Philadelphia.
2045. VERE, DE, SCHEELE M.	Oct. 16, 1885,	University of Virginia, Va.
1475. VIRCHOW, RUDOLPH.	Oct. 17, 1862,	Berlin, Prussia.
1646. VOGT, CARL	Oct. 15, 1869,	Geneva, Switzerland.
2115. VON MELTZEL, HUGO	Dec. 17, 1886,	Kolozsvar, Hungary.
1670. VOSE, GEORGE LEONARD.	Oct. 21, 1870,	Boston, Mass.
2186. VOSSION, LOUIS	Dec. 19, 1890,	Philadelphia.

W

2034. WAGNER, SAMUEL	Jan'y 16, 1885,	Philadelphia.
1748. WAHL, WILLIAM H.	Jan'y 16, 1874,	"
1724. WALLACE, ALFRED R.	April 18, 1873,	Parkston, Dorset, England.
2156. WARD, LESTER F.	May 17, 1889,	Washington, D. C.
2033. WEIL, EDWARD HENRY	Jan'y 16, 1885,	Philadelphia.
2028. WEISBACH, ALBIN	Jan'y 16, 1885,	Freiburg, Saxony.
1639. WHARTON, JOSEPH.	April 16, 1869,	Philadelphia.

<i>Name.</i>	<i>Date of Election.</i>	<i>Present Address.</i>
1637. WHITE, ANDREW D.	April 16, 1869,	Ithaca, N. Y.
1848. WHITE, ISRAEL C.	Jan'y 18, 1878,	Morgantown, W. Va.
1487. WHITNEY, JOSIAH DWIGHT . . .	Jan'y 16, 1863,	Cambridge, Mass.
1502. WHITNEY, WILLIAM DWIGHT. . .	April 17, 1863,	New Haven, Conn.
1863. WILDER, BURT GREEN	May 3, 1878,	Ithaca, N. Y.
2151. WILLIAMS, TALCOTT	May 18, 1888,	Philadelphia.
2178. WILLIS, HENRY	Feb'y 21, 1890,	"
2150. WILSON, EDMUND B.	Feb'y 17, 1888,	Bryn Mawr, Pa.
2041. WILSON, JAMES CORNELIUS. . . .	Jan'y 16, 1885,	Philadelphia.
1747. WILSON, JOSEPH M.	Jan'y 16, 1874,	"
2137. WILSON, WILLIAM POWELL	May 20, 1887,	"
2223. WINSOR, JUSTIN	May 19, 1893,	Cambridge, Mass.
1896. WINTHROP, ROBERT C.	Jan'y 16, 1880,	Boston, Mass.
2140. WIREMAN, HENRY D.	May 20, 1887,	Philadelphia.
2220. WISTAR, ISAAC J.	May 19, 1893,	"
1561. WISTER, OWEN JONES	April 20, 1866,	"
1884. WOOD, RICHARD.	April 18, 1879,	"
1762. WOODWARD, HENRY.	July 17, 1874,	London, England.
1751. WOOTTEN, J. E.	Jan'y 16, 1874,	Reading, Pa.
1854. WORMLEY, THEODORE G.	Jan'y 18, 1878,	Philadelphia.
1932. WURTS, CHARLES STEWART. . . .	Jan'y 21, 1881,	"
2061. WYCKOFF, A. B.	Feb'y 19, 1886,	U. S. Navy.

Y

1904. YARNALL, ELLIS	April 16, 1880,	Philadelphia.
1759. YOUNG, CHARLES AUGUSTUS . . .	April 17, 1874,	Princeton, N. J.

4248

PROCEEDINGS

OF THE

AMERICAN PHILOSOPHICAL SOCIETY

HELD AT PHILADELPHIA FOR PROMOTING USEFUL KNOWLEDGE.

VOL. XXXI.

JANUARY, FEBRUARY, MARCH, 1893.

No. 140.

TABLE OF CONTENTS.

PAGE

<i>Annual Meeting, January 6, 1893</i>	1
<i>Stated Meeting, January 6, 1893</i>	1
<i>Stated Meeting, January 20, 1893</i>	5
<i>Stated Meeting, February 3, 1893</i>	9
<i>Stated Meeting, February 17, 1893</i>	14
Description of the Original Manuscript Journals and Field Note- books of Lewis and Clark, on which was based Biddle's History of the Expedition of 1804-6, and which are now in the possession of the American Philosophical Society, in Philadelphia. <i>By Dr. El-</i> <i>liott Coles</i>	17
Vocabulary of the Kwakiutl Language. <i>By Dr. Franz Boas</i>	34
The Life History of Certain Moths of the Family Cochliopodidæ, with Notes on their Spines and Tubercles (with four plates). <i>By Dr.</i> <i>A. S. Packard</i>	83
The Thyrsos of Dionysos and the Palm Inflorescence of the Winged Figures of Assyrian Monuments. <i>By Dr. Charles S. Dolley</i>	109
Observations on the Psoas Parvus and Pyramidalis. A Study of Variation. <i>By Thomas Dwight, M.D., LL.D.</i>	117
On a New Method of Determining the General Perturbations of the Minor Planets. <i>By W. F. McK. Ritter</i>	124
<i>Stated Meeting, March 3, 1893</i>	128
<i>Stated Meeting, March 17, 1893</i>	130

☞ It is requested that the receipt of this number be acknowledged.

☞ In order to secure prompt attention it is requested that all corre-
spondence be addressed simply "To the Secretaries of the American
Philosophical Society, 104 S. Fifth St., Philadelphia."

PUBLISHED FOR THE SOCIETY

BY

MACCALLA & COMPANY,

NOS. 237-9 DOCK STREET, PHILADELPHIA.

EXTRACT FROM THE LAWS.

CHAPTER XII.

OF THE MAGELLANIC FUND.

SECTION I. John Hyacinth de Magellan, in London, having in the year 1786 offered to the Society, as a donation, the sum of two hundred guineas, to be by them vested in a secure and permanent fund, to the end that the interest arising therefrom should be annually disposed of in premiums, to be adjudged by them to the author of the best discovery, or most useful invention, relating to Navigation, Astronomy, or Natural Philosophy (mere natural history only excepted); and the Society having accepted of the above donation, they hereby publish the conditions, prescribed by the donor and agreed to by the Society, upon which the said annual premiums will be awarded.

CONDITIONS OF THE MAGELLANIC PREMIUM.

1. The candidate shall send his discovery, invention or improvement, addressed to the President, or one of the Vice-Presidents of the Society, free of postage or other charges; and shall distinguish his performance by some motto, device, or other signature, at his pleasure. Together with his discovery, invention, or improvement, he shall also send a sealed letter containing the same motto, device, or signature, and subscribed with the real name and place of residence of the author.

2. Persons of any nation, sect or denomination whatever, shall be admitted as candidates for this premium.

3. No discovery, invention or improvement shall be entitled to this premium, which hath been already published, or for which the author hath been publicly rewarded elsewhere.

4. The candidate shall communicate his discovery, invention or improvement, either in the English, French, German, or Latin language.

5. All such communications shall be publicly read or exhibited to the Society at some stated meeting, not less than one month previous to the day of adjudication, and shall at all times be open to the inspection of such members as shall desire it. But no member shall carry home with

4248

PROCEEDINGS

OF THE

AMERICAN PHILOSOPHICAL SOCIETY

HELD AT PHILADELPHIA FOR PROMOTING USEFUL KNOWLEDGE.

VOL. XXXI.

APRIL, MAY, JUNE, 1893.

No. 141.

TABLE OF CONTENTS.

	PAGE
<i>Stated Meeting, April 7, 1893.....</i>	135
<i>Stated Meeting, April 21, 1893.....</i>	137
The Life Histories of Certain Moths of the Families Ceratocampidæ, Hemileucidæ, etc., with Notes on the Armature of the Larvæ (with seven plates). <i>By Alpheus S. Packard.....</i>	139
Energy as a Factor in Organic Evolution. <i>By John A. Ryder....</i>	192
The Mechanical Genesis of the Form of the Fowl's Egg (with one cut). <i>By John A. Ryder.....</i>	203
Notes on the Classification and Taxonomy of the Testudinata. <i>By G. Baur.....</i>	210
<i>Stated Meeting, May 5, 1893.....</i>	226
<i>Stated Meeting, May 19, 1893.....</i>	228

☞ It is requested that the receipt of this number be acknowledged.

☞ In order to secure prompt attention it is requested that all correspondence be addressed simply "To the Secretaries of the American Philosophical Society, 104 S. Fifth St., Philadelphia."

PUBLISHED FOR THE SOCIETY

BY

MACCALLA & COMPANY,

NOS. 237-9 DOCK STREET, PHILADELPHIA.

EXTRACT FROM THE LAWS.

THE HENRY M. PHILLIPS PRIZE ESSAY FUND.

Miss Emily Phillips, of Philadelphia, a sister of Hon. Henry M. Phillips, deceased, presented to the American Philosophical Society, held at Philadelphia for Promoting Useful Knowledge, the sum of five thousand dollars for the establishment and endowment of a Prize Fund, in memory of her deceased brother, who was an honored member of the Society. The Society accepted the gift and agreed to make suitable rules and regulations to carry out the wishes of the donor, and to discharge the duties confided to it. In furtherance whereof, the following rules and regulations were adopted by the Society :

First. The Prize Endowment Fund shall be called the "Henry M. Phillips Prize Essay Fund."

Second. The money constituting the Endowment Fund, *viz.*, five thousand dollars, shall be invested by the Society in such securities as may be recognized by the laws of Pennsylvania, as proper for the investment of trust funds, and the evidences of such investment shall be made in the name of the Society as Trustee of the Henry M. Phillips Prize Essay Fund.

Third. The income arising from such investment shall be appropriated as follows :

(a) To making public advertisement of the prize and the sum or amount in United States gold coin, and the terms on which it shall be awarded.

(b) To the payment of such prize or prizes as may from time to time be awarded by the Society for the best essay of real merit on

PROCEEDINGS
OF THE
AMERICAN PHILOSOPHICAL SOCIETY
HELD AT PHILADELPHIA FOR PROMOTING USEFUL KNOWLEDGE.

VOL. XXXI.

JULY TO DECEMBER, 1893.

No. 142.

4248

TABLE OF CONTENTS.

	PAGE
<i>Stated Meeting, September 1, 1893</i>	233
<i>Stated Meeting, September 15, 1893</i>	242
<i>Stated Meeting, October 6, 1893</i>	247
<i>Stated Meeting, October 20, 1893</i>	252
A Notice of William Barton Rogers. <i>By W. S. W. Ruschenberger, M.D.</i>	254
The Native Calendar of Central America and Mexico. A Study in Linguistics and Symbolism <i>By Daniel G. Brinton, M.D.</i>	256
The Great Mesozoic Fault in New Jersey (with one plate). <i>By Benjamin Smith Lyman</i>	314
On the genus <i>Tomioipsis</i> . <i>By E. D. Cope</i>	317
The Conservation of Osmazome in Roasting (with two figures). <i>By R. Meade Bache</i>	318
A Vocabulary of the Nanticoke Dialect. <i>By Daniel G. Brinton, M.D.</i>	325
Second Addition to the Knowledge of the Batrachia and Reptilia of Costa Rica. <i>By E. D. Cope</i>	333
<i>Stated Meeting, November 3, 1893</i>	348
<i>Stated Meeting, November 17, 1893</i>	351
<i>Stated Meeting, December 1, 1893</i>	355
<i>Stated Meeting, December 15, 1893</i>	356
Obituary Notice of Joseph Zentmayer (with one plate). <i>By Charles A. Oliver, M.D.</i>	358
Volumes and Dates of Proceedings and Transactions of the American Philosophical Society	365

☞ It is requested that the receipt of this number be acknowledged.

☞ In order to secure prompt attention it is requested that all correspondence be addressed simply "To the Secretaries of the American Philosophical Society, 104 S. Fifth St., Philadelphia."

PUBLISHED FOR THE SOCIETY

BY

MACCALLA & COMPANY,

NOS. 237-9 DOCK STREET, PHILADELPHIA.

EXTRACT FROM THE LAWS.

CHAPTER XII.

OF THE MAGELLANIC FUND.

SECTION I. John Hyacinth de Magellan, in London, having in the year 1786 offered to the Society, as a donation, the sum of two hundred guineas, to be by them vested in a secure and permanent fund, to the end that the interest arising therefrom should be annually disposed of in premiums, to be adjudged by them to the author of the best discovery, or most useful invention, relating to Navigation, Astronomy, or Natural Philosophy (mere natural history only excepted); and the Society having accepted of the above donation, they hereby publish the conditions, prescribed by the donor and agreed to by the Society, upon which the said annual premiums will be awarded.

CONDITIONS OF THE MAGELLANIC PREMIUM.

1. The candidate shall send his discovery, invention or improvement, addressed to the President, or one of the Vice-Presidents of the Society, free of postage or other charges; and shall distinguish his performance by some motto, device, or other signature, at his pleasure. Together with his discovery, invention, or improvement, he shall also send a sealed letter containing the same motto, device, or signature, and subscribed with the real name and place of residence of the author.

2. Persons of any nation, sect or denomination whatever, shall be admitted as candidates for this premium.

3. No discovery, invention or improvement shall be entitled to this premium, which hath been already published, or for which the author hath been publicly rewarded elsewhere.

4. The candidate shall communicate his discovery, invention or improvement, either in the English, French, German, or Latin language.

5. All such communications shall be publicly read or exhibited to the Society at some stated meeting, not less than one month previous to the day of adjudication, and shall at all times be open to the inspection of such members as shall desire it. But no member shall carry home with



3 2044 093 310 571

