

S. 1.

A. 58

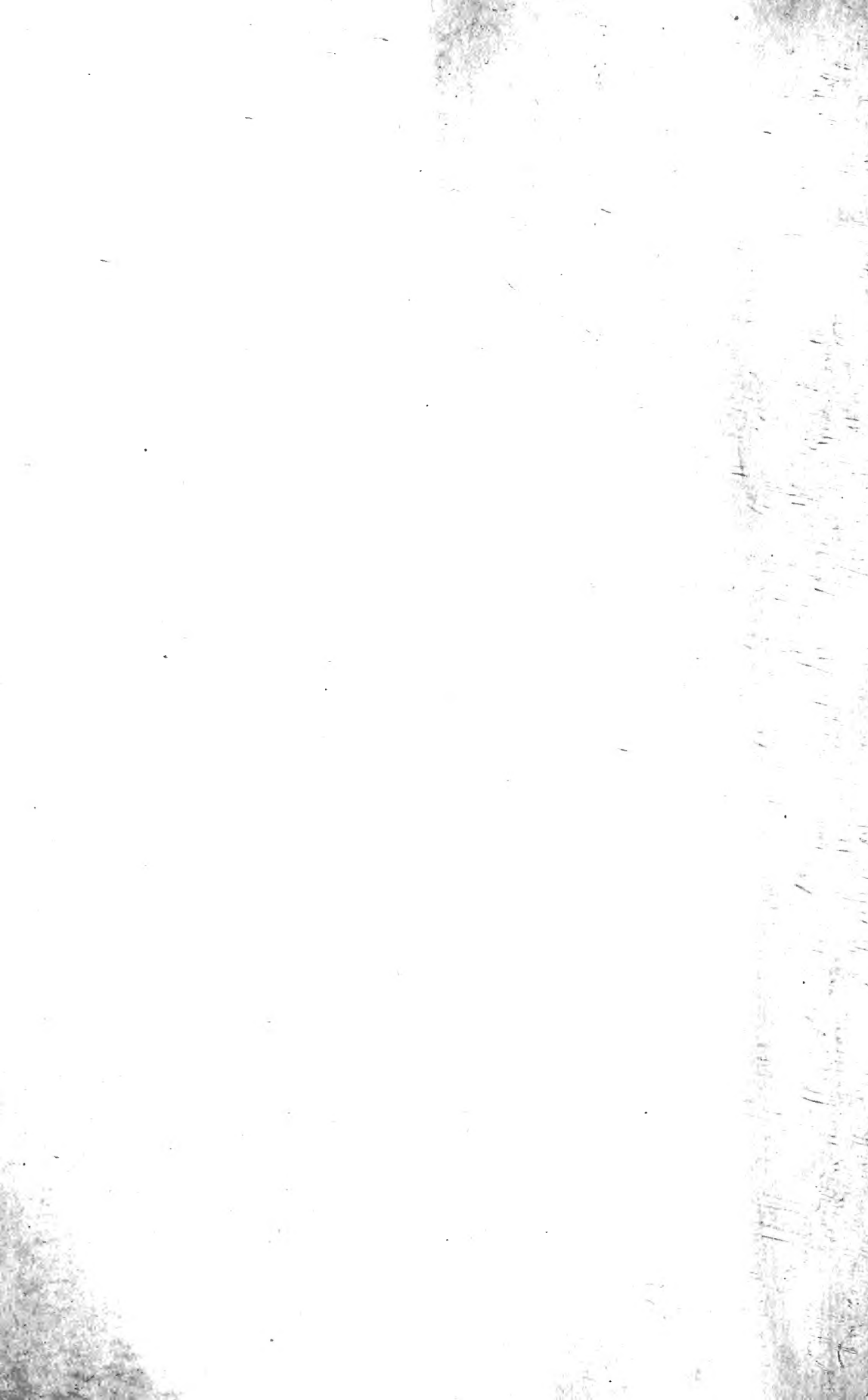

PROCEEDINGS
OF THE
GENERAL MEETINGS FOR SCIENTIFIC BUSINESS
OF THE
ZOOLOGICAL SOCIETY
OF LONDON
FOR THE YEAR
1898.

PART I.
CONTAINING PAPERS READ IN
JANUARY AND FEBRUARY.



JUNE 1st, 1898.

PRINTED FOR THE SOCIETY,
SOLD AT THEIR HOUSE IN HANOVER SQUARE
LONDON:
MESSRS. LONGMANS, GREEN, AND CO.,
PATERNOSTER-ROW.

[*Price Twelve Shillings.*]

LIST OF CONTENTS.

PART I.—1898.

January 18, 1898.

	Page
The Secretary. Report on the Additions to the Society's Menagerie in December 1897. (Plate I.)	1
The Secretary. Exhibition, on behalf of Dr. R. Collett, of a specimen of a supposed hybrid between the Fieldfare (<i>Turdus pilaris</i>) and the Redwing (<i>T. iliaeus</i>)	3
Mr. W. E. de Winton. Exhibition of a skin of a Zebra (<i>Equus boehmi</i>) from British East Africa	3
1. On the Development of the Hyobranchial Skeleton of the Midwife-Toad (<i>Alytes obstetricans</i>). By W. G. RIDGEWOOD, D.Sc., F.L.S., Lecturer on Biology at St. Mary's Hospital Medical School, London. (Plate II.)	4
2. On the Cteniform Spiders of Africa, Arabia, and Syria. By FREDK. O. PICKARD CAMBRIDGE, B.A. (Plates III. & IV.)	13
3. On some Crustaceans from the South Pacific.—Part I. <i>Stomatopoda</i> . By LANCELOT ALEXANDER BORRADAILE, M.A., Lecturer in Natural Sciences at Selwyn College, Cambridge. (Plates V. & VI.)	32

February 1, 1898.

Mr. Oldfield Thomas. Exhibition of, and remarks upon, the skull of a supposed new sub-species of Giraffe from West Africa, proposed to be named <i>Giraffu camelopardalis peralta</i>	39
Mr. Selater. Exhibition of photographs of Giraffes showing the differences in markings between the two recognized forms	41
Mr. J. Graham Kerr. Notes on the dry-season habits of <i>Lepidosiren</i> , communicated to him in a letter by Mr. R. J. Hunt, of Paraguay	41
Mr. G. A. Boulenger, F.R.S. Notice of a memoir on the Fishes collected by Dr. J. Bach in the Rio Jurua, Brazil	44

PROCEEDINGS

OF THE

GENERAL MEETINGS FOR SCIENTIFIC BUSINESS

OF THE

ZOOLOGICAL SOCIETY

OF LONDON

FOR THE YEAR

1898.



PRINTED FOR THE SOCIETY,
AND SOLD AT THEIR HOUSE IN HANOVER-SQUARE

LONDON:

MESSRS. LONGMANS, GREEN, AND CO.,
PATERNOSTER ROW.

L I S T
OF THE
COUNCIL AND OFFICERS
OF THE
ZOOLOGICAL SOCIETY OF LONDON.

1898.

COUNCIL.

(Elected April 29, 1898.)

SIR W. H. FLOWER, K.C.B., LL.D., D.C.L., Sc.D., F.R.S., *President.*

WILLIAM BATESON, Esq., F.R.S.

HIS GRACE THE DUKE OF BEDFORD.

COL. JOHN BIDDULPH.

WILLIAM T. BLANFORD, Esq.,

LL.D., F.R.S., *Vice-President.*

GEORGE A. BOULENGER, Esq.,

F.R.S.

EDWARD NORTH BUNTON, Esq.

HERBERT DRUCE, Esq., F.L.S.

CHARLES DRUMMOND, Esq., *Treasurer.*

SIR JOSEPH FAYRER, Bt., K.C.S.I.,

F.R.S., *Vice-President.*

GEN. THE HON. SIR PERCY

FEILDING, K.C.B.

F. DUCANE GODMAN, Esq., F.R.S.,
Vice-President.

DR. ALBERT GÜNTHER, F.R.S.,
Vice-President.

PROFESSOR GEORGE B. HOWES,
LL.D., F.R.S., *Vice-President.*

LT.-COL. LEONARD H. IRBY.

RICHARD LYDEKKER, Esq., F.R.S.

DR. ST. GEORGE MIVART, F.R.S.,
Vice-President.

SIR THOMAS PAINE.

HOWARD SAUNDERS, Esq., F.L.S.

PHILIP LUTLEY SCLATER, Esq.,

M.A., Ph.D., F.R.S., *Secretary.*

CHARLES S. TOMES, Esq., F.R.S.

PRINCIPAL OFFICERS.

P. L. SCLATER, Esq., M.A., Ph.D., F.R.S., *Secretary.*

FRANK E. BEDDARD, Esq., M.A., F.R.S., *Vice-Secretary and
Prosector.*

MR. CLARENCE BARTLETT, *Superintendent of the Gardens.*

MR. F. H. WATERHOUSE, *Librarian.*

MR. JOHN BARROW, *Accountant.*

MR. W. H. COLE, *Chief Clerk.*

LIST
OF THE
CONTRIBUTORS,

With References to the several Articles contributed by each.

	Page
ALCOCK, N. H., B.A., M.D., Assistant to the Professor of Institutes of Medicine, Trinity College, Dublin.	
On the Vascular System of the Chiroptera.—Part I. Thoracic Vessels of <i>Pteropus medius</i> ; with a Summary of the Literature of the Chiroptera	58
ANDREWS, CHARLES WILLIAM, B.Sc., B.A., F.Z.S.	
Exhibition of, and remarks upon, some Bird-remains from the Lake-dwellings of Glastonbury, Somersetshire..	852
BEDDARD, FRANK E., M.A., F.R.S., Vice-Secretary and Prosector to the Society.	
On the Anatomy of an Australian Cuckoo, <i>Scythrops novae-hollandiae</i>	44
On certain Points in the Anatomy of the Cunning Bassarisc (<i>Bassariscus astutus</i>)	129

	Page
BEDFORD, F. P., B.A., King's College, Cambridge.	
Report on the Holothurians collected by Mr. J. Stanley Gardiner at Funafuti and Rotuma. (Plates LII. & LIII.)	834
BELL, FRANCIS JEFFREY, M.A., F.Z.S.	
On the Actinogonidiate Echinoderms collected by Mr. J. Stanley Gardiner at Funafuti and Rotuma	849
BLANFORD, W. T., LL.D., F.R.S., V.P.Z.S., &c.	
Notes on <i>Lepus oiostolus</i> and <i>L. pallipes</i> from Tibet, and on a Kashmir Macaque	357
BORRADAILE, LANCELOT ALEXANDER, M.A., F.Z.S., Lecturer in Natural Sciences at Selwyn College, Cambridge.	
On some Crustaceans from the South Pacific.—Part I. <i>Stomatopoda</i> . (Plates V. & VI.)	32
On some Crustaceans from the South Pacific.—Part II. <i>Macrura anomala</i> . (Plate XXXVI.)	457
On some Crustaceans from the South Pacific.—Part III. <i>Macrura</i> . (Plates LXIII.—LXV.)	1000
BOULENGER, GEORGE ALBERT, F.R.S., F.Z.S.	
Notice of a Memoir on the Fishes collected by Dr. J. Bach in the Rio Jurua, Brazil.	44
Description of a new Sea-Snake from Borneo. (Plate IX.)	106
An Account of the Reptiles and Batrachians collected by Mr. W. F. H. Rosenberg in Western Ecuador. (Plates X.—XVIII.)	107
Exhibition of a living specimen of a hybrid Newt between a male <i>Molge cristata</i> × <i>M. marmorata</i> and a female of <i>M. cristata</i>	127

	Page
BOULENGER, GEORGE ALBERT, F.R.S., F.Z.S. (<i>Continued.</i>)	
A Revision of the African and Syrian Fishes of the Family <i>Cichlidae</i> .—Part I. (Plate XIX.)	132
Fourth Report on Additions to the Batrachian Collection in the Natural-History Museum. (Plates XXXVIII. & XXXIX.)	473
Exhibition of, and remarks upon, specimens of <i>Polypterus lapradii</i> from the Lower Congo	493
Notice of a Memoir on the Fishes collected by Mr. J. E. S. Moore in Lake Tanganyika	494
A Revision of the Genera and Species of Fishes of the Family <i>Mormyridae</i> . (Plate LI.)	775
Exhibition of, and remarks upon, a dancing-stick from New Guinea to which two skulls of the Chelonian <i>Carettochelys insculpta</i> were attached	851
Exhibition of, and remarks upon, a specimen of a Sea-snake (<i>Distira stokesii</i>)	851
Third Report on Additions to the Lizard Collection in the Natural-History Museum. (Plates LV.—LVII.)	912
BRADY, G. STEWARDSON, M.D., LL.D., C.M.Z.S.	
Notice of a Memoir on new or imperfectly known Species of Ostracoda, chiefly from New Zealand	203
BRINDLEY, H. H., M.A., St. John's College, Cambridge.	
On certain Characters of reproduced Appendages in Arthropoda, particularly in the <i>Blattidae</i> . (Plate LVIII.)	924
BUDGETT, JOHN S., F.Z.S.	
Extracts from a letter from, on his Expedition to the Gambia	852

	Page
BURR, MALCOLM, F.Z.S., DIXEY, F. A., M.A., M.D., and CAMBRIDGE, Rev. O. PICKARD-, M.A., F.R.S., C.M.Z.S.	
On a Collection of Insects and Arachnids made by Mr. E. N. Bennett in Socotra, with Descriptions of new Species. (Plates XXX. & XXXI.)	372
BUSHELL, S. W., C.M.G., M.D., B.Sc., C.M.Z.S.	
Extract from letter from, on the herd of <i>Cervus david-</i> <i>ianus</i> in the Imperial Hunting Park, Peking	588
BUTLER, ARTHUR G., Ph.D., F.L.S., F.Z.S., &c., Senior Assistant-Keeper, Zoological Department, British Museum.	
On a Collection of Lepidoptera made by Mr. F. V. Kirby, chiefly in Portuguese East Africa	49
On the Lepidopterous Insects collected by Mr. G. A. K. Marshall in Natal and Mashonaland in 1895 and 1897. (Plate XX.)	186
On a Collection of Lepidoptera made in British East Africa by Mr. C. S. Betton. (Plates XXXII. & XXXIII.)	395
A List of Butterflies obtained in the Harar Highlands by Capt. H. G. C. Swayne, R.E.	821
On a small Collection of Butterflies made in the Chikala District, British Central Africa, by Mr. George Hoare ..	823
On a small Collection of Butterflies from British East Africa, obtained at the end of 1897 and beginning of 1898 by Mr. R. Crawshay	825
On a Collection of Butterflies almost entirely made at Salisbury, Mashonaland, by Mr. Guy A. K. Marshall, in 1898	902
BYRNE, L. W., F.Z.S., and HOLT, ERNEST W. L.	
Exhibition of, and remarks upon, specimens and drawings of a supposed new Sucker-fish (<i>Lepadogaster</i> <i>stictopteryx</i>)	589

	Page
CAMBRIDGE, FREDERICK O. PICKARD-, B.A.	
On the Cteniform Spiders of Africa, Arabia, and Syria. (Plates III. & IV.)	13
On new Species of Spiders from Trinidad, West Indies. (Plate LIV.)	890
CAMBRIDGE, Rev. O. PICKARD-, M.A., F.R.S., C.M.Z.S.	
Note on the generic name <i>Eatonia</i>	348
On some Spiders from Savoy.	487
CAMBRIDGE, Rev. O. PICKARD-, M.A., F.R.S., C.M.Z.S., DIXEY, F. A., M.A., M.D., and BURR, MALCOLM, F.Z.S.	
On a Collection of Insects and Arachnids made by Mr. E. N. Bennett in Socotra, with Descriptions of new Species. (Plates XXX. & XXXI.)	372
COLLETT, Prof. ROBERT, F.M.Z.S.	
On some Pigeons and Parrots from North and North- west Australia. (Plates XXVIII. & XXIX.)	353
CUNNINGHAM, J. T., M.A.	
On the Early Post-larval Stages of the Common Crab (<i>Cancer pagurus</i>), and on the Affinity of that Species with <i>Atelecyclus heterodon</i> . (Plate XXI.)	204
DEAN, Dr. BASHFORD.	
Remarks on the Affinities of <i>Palæospondylus gunni</i> . In reply to Dr. R. H. Traquair	343
DE WINTON, W. E., F.Z.S.	
Exhibition of a skin of a Zebra (<i>Equus boehmi</i>) from British East Africa	3

	Page
DE WINTON, W. E., F.Z.S. (<i>Continued.</i>)	
Exhibition of, and remarks upon, a head-skin of a Roan Antelope (<i>Hippotragus equinus</i>) from British East Africa.	127
On a new Genus and Species of Rodents of the Family <i>Anomaluridae</i> from West Africa. (Plates XXXIV. & XXXV.)	450
List of the Mammals obtained by Mr. R. McD. Hawker during his recent Expedition to Somaliland.	761
On the Moulting of the King Penguin (<i>Aptenodytes pennanti</i>) in the Society's Gardens	900
DIXEY, F. A., M.A., M.D., BURR, MALCOLM, F.Z.S., and CAMBRIDGE, Rev. O. PICKARD-, M.A., F.R.S., C.M.Z.S.	
On a Collection of Insects and Arachnids made by Mr. E. N. Bennett in Socotra, with Descriptions of new Species. (Plates XXX. & XXXI.)	372
DUCKWORTH, W. L. H., M.A., Fellow of Jesus College, Cambridge.	
Note on an Anthropoid Ape	989
DUGÈS, ALFRED, M.D.	
Description d'un Genre nouveau d'Ophidiens, <i>Geotracetus</i>	539
FEDARB, Miss SOPHIE M.	
On some Earthworms from British India	445
FLOWER, STANLEY S., 5th Fusiliers, F.Z.S., Director of the Zoological Gardens, Cairo, Egypt.	
On the Identification of a Gecko from Penang	455
Extract from letter from, on the locality of the Siamang (<i>Hylobates syndactylus</i>)	924

	Page
FOWLER, G. HERBERT, B.A., Ph.D., Assistant Professor of Zoology, University College, London.	
Contributions to our Knowledge of the Plankton of the Faeroe Channel.—No. VI. Description of a new Mid- water Tow-net. Discussion of the Mid-water Fauna (Mesoplankton). Notes on <i>Doliolum tritonis</i> and <i>D. na- tionalis</i> , and on <i>Parathemisto abyssorum</i>	567
Contributions to our Knowledge of the Plankton of the Faeroe Channel.—No. VII. A. General Data of the Stations. B. The Protozoa. C. The Medusæ. (Plate LXVI.)	1016
FOWLER, G. HERBERT, B.A., Ph.D., Assistant Professor of Zoology, University College, London, and THOMPSON, ISAAC C., F.L.S.	
Contributions to our Knowledge of the Plankton of the Faeroe Channel.—No. IV. Report on the Copepoda collected by Dr. G. H. Fowler from H.M.S. 'Research' in the Faeroe Channel in 1896 and 1897.	540
GARDINER, J. STANLEY, M.A., Gonville and Caius College, Cambridge.	
On the Perforate Corals collected by the Author in the South Pacific. (Plates XXIII. & XXIV.)	257
On the Fungid Corals collected by the Author in the South Pacific. (Plates XLIII.—XLV.)	525
On the Turbinolid and Oculinoid Corals collected by the Author in the South Pacific. (Plate LXII.)	994
GOELDI, DR. EMIL A., C.M.Z.S., Pará.	
Further Notes on the Amazonian Lepidosiren	852
GORHAM, The Rev. HENRY S., F.Z.S.	
On the Serricorn Coleoptera of St. Vincent, Grenada, and the Grenadines (<i>Malacodermata</i> , <i>Ptinidæ</i> , <i>Bostrychidæ</i>), with Descriptions of new Species. (Plate XXVII. figs. 1-5 & 7-10.)	315

	Page
GORHAM, The Rev. HENRY S., F.Z.S. (Continued.)	
On the Coleoptera of the Families <i>Erotylidæ</i> , <i>Endomychidæ</i> , and <i>Coccinellidæ</i> , collected by Mr. H. H. Smith in St. Vincent, Grenada, and the Grenadines, with Descriptions of new Species. (Plate XXVII. figs. 6, 11, 12.) . .	334
HAMPSON, Sir GEORGE F., Bart., F.Z.S.	
A Revision of the Moths of the Subfamily <i>Pyraustineæ</i> and Family <i>Pyralidæ</i> .—Part I. (Plates XLIX. & L.) . .	590
HICKSON, SYDNEY J., M.A., D.Sc., F.R.S., F.Z.S.	
On the Species of the Genus <i>Millepora</i> : a preliminary Communication	246
Notes on the Collection of Specimens of the Genus <i>Millepora</i> obtained by Mr. J. Stanley Gardiner at Funafuti and Rotuma	828
HOLDING, R. E.	
Exhibition of, and remarks upon, a pair of horns of the "Sunga" or Galla Ox of Abyssinia	202
Remarks on the Zoological Gardens at Belle Vue, Manchester	493
HOLT, ERNEST W. L.	
Exhibition of, and remarks upon, some advanced larvæ of the luminous Fish <i>Scopelus glacialis</i>	279
On the Breeding of the Dragonet (<i>Callionymus lyra</i>) in the Marine Biological Association's Aquarium at Plymouth; with a preliminary account of the Elements, and some remarks on the significance of the Sexual Dimorphism. (Plate XXVI.)	281
Contributions to our Knowledge of the Plankton of the Faeroe Channel.—No. V. Report on a Collection of very young Fishes obtained by Dr. G. H. Fowler in the Faeroe Channel. (Plates XLVI. & XLVII.)	550

	Page
HOLT, ERNEST W. L., and BYRNE, L. W., F.Z.S.	
Exhibition of, and remarks upon, specimens and drawings of a supposed new Sucker-fish (<i>Lepadogaster stictopteryx</i>).....	589
HOWES, G. B., LL.D., F.R.S., V.P.Z.S.	
Exhibition, on behalf on Mr. E. W. L. Holt, of a specimen of a new British Fish (<i>Argentina silus</i>)	493
Exhibition of, and remarks upon, series of embryos and living eggs of the Tuatera (<i>Sphenodon punctatus</i>)	589
JACOBY, MARTIN, F.E.S.	
Additions to the Knowledge of the Phytophagous Coleoptera of Africa.—Part I. (Plate XXII.)	212
JOHNSTON, Sir HARRY H., K.C.B., F.Z.S.	
On the Larger Mammals of Tunisia	351
KERR, J. GRAHAM, F.Z.S.	
Notes on the dry-season habits of <i>Lepidosiren</i> , communicated to him in a letter by Mr. R. J. Hunt, of Paraguay	41
Exhibition of specimens of <i>Lepidosiren</i> and other Fishes collected in the Gran Chaco of Paraguay	492
LE SOUËF, DUDLEY, C.M.Z.S.	
Letter from, on the transfer by the mother of an embryo Kangaroo (<i>Macropus giganteus</i>) by her mouth into her pouch	79
LYDEKKER, RICHARD, B.A., F.R.S., F.Z.S.	
On the Geographical Races of the Banting. (Plate XXV.).....	276
MITCHELL, P. CHALMERS, M.A., F.Z.S.	
Exhibition of, and remarks upon, some etched studies of young Orang-Outangs	851

NEUMANN, OSCAR.

On a new Antelope of the Genus *Hippotragus* 850

PARSONS, F. G., F.R.C.S., F.Z.S., F.L.S., Lecturer on Comparative Anatomy at St. Thomas's Hospital, and Hunterian Professor at the Royal College of Surgeons.

On the Anatomy of the African Jumping-Hare (*Pedetes caffer*) compared with that of the *Dipodidae* 858

PARSONS, F. G., F.R.C.S., F.Z.S., F.L.S., Lecturer on Comparative Anatomy at St. Thomas's Hospital, and Hunterian Professor at the Royal College of Surgeons, and WINDLE, B. C. A., M.A., M.D., D.Sc., Professor of Anatomy at Mason University College, Birmingham.

The Myology of the Terrestrial Carnivora.—Part II. 152

PERACCA, Count M. G., D.Sc., Ph.D., F.Z.S.

Note on an Italian Newt, *Molge italica*. (Plate XL.) 482

POCOCK, R. I., of the British Museum (Natural History).

On the Scorpions, Spiders, and Solpugas collected by Mr. C. Steuart Betton in British East Africa. (Plates XLI. & XLII.) 497

PYCRAFT, W. P.

Contributions to the Osteology of Birds.—Part I. *Steganopodes*. (Plates VII. & VIII.) 82

Contributions to the Osteology of Birds.—Part II. *Impennes*. (Plates LIX.—LXI.) 958

RIDEWOOD, W. G., D.Sc., F.L.S., F.Z.S., Lecturer on Biology at St. Mary's Hospital Medical School, London.

On the Development of the Hyobranchial Skeleton of the Midwife-Toad (*Alytes obstetricans*). (Plate II.) 4

On the Skeleton of Regenerated Limbs of the Midwife-Toad (*Alytes obstetricans*) 101

	Page
ROTHSCHILD, Hon. WALTER, F.Z.S.	
Exhibition of a mounted specimen of the Ribbon-fish, <i>Regalecus argenteus</i> (?)	280
SCHUSTER, E. H. J., F.Z.S.	
On a new Flagellate Protozoon of the genus <i>Lophomonas</i> .	242
SCLATER, PHILIP LUTLEY, M.A., Ph.D., F.R.S., Secretary to the Society.	
Report on the Additions to the Society's Menagerie in December 1897. (Plate I.)	1
Exhibition, on behalf of Dr. R. Collett, of a supposed hybrid between the Fieldfare (<i>Turdus pilaris</i>) and the Redwing (<i>T. iliacus</i>)	3
Exhibition of photographs of Giraffes showing the dif- ferences in markings between the two recognized forms..	41
Report on the Additions to the Society's Menagerie in January 1898	79
Exhibition of a series of Lepidopterous Insects showing the system of mounting adopted in 'Denton's Patent Butterfly Tablets'	81
Exhibition of, and remarks upon, two skins of the White- legged Falconet (<i>Microhierax melanoleucus</i>)	128
Report on the Additions to the Society's Menagerie in February 1898	201
Exhibition of, on behalf of Sir Edmund Loder, Bart., and remarks upon, some photographs of the Beaver-pond at Leonardslee, Horsham	201
Report on the Additions to the Society's Menagerie in March 1898	245
Remarks on the principal animals observed during recent visits to the Marseilles Garden, the menagerie of the Bey of Tunis at Marsa, and the Jardin d'Acclimatation, Paris.	280

	Page
SCLATER, PHILIP LUTLEY, M.A., Ph.D., F.R.S. (<i>Continued.</i>)	
Report on the Additions to the Society's Menagerie in April 1898	348
Exhibition of, and remarks upon, some specimens of Mammals from the Gambia, with a List of the Antelopes known from that Colony	349
Report on the Additions to the Society's Menagerie in May 1898	456
Remarks on the arrival in the Society's Gardens of four living specimens of the Australian Lung-fish (<i>Ceratodus forsteri</i>)	492
Reports on the Additions to the Society's Menagerie in June, July, August, September, and October 1898. (Plate XLVIII.)	585
Exhibition of, and remarks upon, a photograph of Grévy's Zebra (<i>Equus grevii</i>)	588
Exhibition of a set of photographs of the Bangkok Museum, Siam	588
Report on the Additions to the Society's Menagerie in November 1898	924
SHARPE, Miss EMILY MARY.	
On a Collection of Lepidopterous Insects from San Domingo. With Field-notes by the Collector, Dr. CUTHBERT CHRISTY	362
A List of the Lepidopterous Insects collected by Mrs. Lort Phillips in Somaliland	369
SHIPLEY, ARTHUR E., F.Z.S., Fellow and Tutor of Christ's College, Cambridge, and University Lecturer in the Advanced Morphology of the Invertebrata.	
Report on the Gephyrean Worms collected by Mr. J. Stanley Gardiner at Rotuma and Funafuti. (Plate XXXVII.)	468

	Page
THAYER, ABBOTT H.	
Remarks on his method of demonstrating the underlying principle of protective coloration in animals	494
THOMAS, OLDFIELD, F.Z.S.	
Exhibition of, and remarks upon, the skull of a supposed new subspecies of Giraffe from West Africa, proposed to be named <i>Giraffa camelopardalis peralta</i>	39
On some Mammals obtained by the late Mr. Henry Durnford in Chubut, E. Patagonia	210
Exhibition of, and remarks upon, a series of specimens of a Siamese Squirrel showing variability in coloration ..	245
Description of a new Dik-dik Antelope (<i>Madoqua</i>) discovered in N.E. Africa by Mr. H. S. H. Cavendish.....	278
On a small Collection of Mammals obtained by Mr. Alfred Sharpe, C.B., in Nyasaland	391
On Mammals collected by Mr. J. D. La Touche at Kuatun, N.W. Fokien, China	769
Extract from letter from Señor Ameghino on the newly-discovered Mammal <i>Neomylodon</i>	852
THOMPSON, ISAAC C., F.L.S., and FOWLER, G. HERBERT, B.A., Ph.D., Assistant Professor of Zoology, University College, London.	
Contributions to our Knowledge of the Plankton of the Faeroe Channel.—No. IV. Report on the Copepoda collected by Dr. G. H. Fowler from H.M.S. 'Research' in the Faeroe Channel in 1896 and 1897.....	540
THOMSON, ARTHUR, Head-Keeper of the Society's Menagerie.	
Report on the Insect-house for 1897	80
WIGLESWORTH, L. W.	
Remarks on the Theories of the Origin of Secondary Sexual Characters	457

	Page
WINDLE, B. C. A., M.A., M.D., D.Sc., Professor of Anatomy at Mason University College, Birmingham, and PARSONS, F. G., F.R.C.S., F.Z.S., F.L.S., Lecturer on Comparative Anatomy at St. Thomas's Hospital. and Hunterian Professor at the Royal College of Surgeons.	
The Myology of the Terrestrial Carnivora.—Part II...	152
WOODWARD, HENRY, LL.D., F.R.S., F.G.S., F.Z.S.	
Exhibition of, and remarks upon, an abnormal pair of antlers of the Red Deer	924

LIST OF PLATES.

1898.

Plate		Page
I.	<i>Felis dominicanorum</i>	2
II.	Hyoid of <i>Alytes obstetricans</i>	4
III. } IV. }	African Cteniform Spiders	13
V. } VI. }	Stomatopoda from the South Pacific	32
VII.	Osteology of Steganopodes.—Fig. 1. <i>Fregata ariel</i> . Fig. 2. <i>Phaëthon flavirostris</i> . Fig. 3. <i>Phalacrocorax carbo</i>	82
VIII.	Osteology of Steganopodes.—Figs. 1, 1 a, 5. <i>Phaëthon flavirostris</i> . Fig. 2. <i>Sula leucogastra</i> . Fig. 3. <i>Phalacrocorax carbo</i> . Fig. 4. <i>Fregata ariel</i> . Fig. 5. <i>Pelecanus rufescens</i>	82
IX.	<i>Hydrophis floweri</i>	106
X.	Fig. 1. <i>Anolis peraccæ</i> . Fig. 2. <i>A. elegans</i> . Fig. 3. <i>A. chloris</i> . Fig. 4. <i>A. lemniscatus</i>	107
XI.	Fig. 1. <i>Anolis maculiventris</i> . Fig. 2. <i>A. granuliceps</i> . Fig. 3. <i>A. gracilipes</i>	
XII.	Fig. 1. <i>Synophis niops</i> . Fig. 2. <i>Leptognathus ellipsifera</i>	
XIII.	<i>Elaps rosenbergi</i>	
XIV.	Fig. 1. <i>Phyllobates infraguttatus</i> . Fig. 2. <i>Hylodes anomalus</i> . Fig. 3. <i>Syrrhopus areolatus</i> . Fig. 4. <i>Leptodactylus pulcher</i>	
XV.	Fig. 1. <i>Hylodes longirostris</i> . Fig. 2. <i>H. achatinus</i> . Fig. 3. <i>H. gularis</i> . Fig. 4. <i>H. latidiscus</i>	
XVI.	<i>Hyla rosenbergi</i>	
XVII.	Fig. 1. <i>Nototrema angustifrons</i> . Fig. 2. <i>Hylella parabambæ</i>	
XVIII.	<i>Nototrema cornutum</i>	
XIX.	Fig. 1. <i>Pelmatochromis welwitschi</i> . Fig. 2. <i>Chromidotilapia kingsleyæ</i>	132
XX.	Butterflies from Natal	186
XXI.	<i>Cancer pagurus</i> . First Post-larval Stages, magnified.	204

Plate	Page
XXII.	New species of African Phytophagous Coleoptera 212
XXIII.	} Corals from the South Pacific 257
XXIV.	
XXV.	Heads of (1) Burmese and (2) Javan Races of the Banting (<i>Bos sondaicus</i>) 276
XXVI.	<i>Callionymus lyra</i> 281
XXVII.	Serricorn and other Coleoptera from the West Indies 315 & 334
XXVIII.	<i>Petrophassa rufipennis</i> } 353
XXIX.	<i>Ptilopus (Leucotreron) alligator</i> }
XXX.	Insects from Socotra } 372
XXXI.	Araneidea from Socotra }
XXXII.	} British-East-African Lepidoptera 395
XXXIII.	
XXXIV.	} <i>Aëthurus glirinus</i> 450
XXXV.	
XXXVI.	<i>Macrura anomala</i> from the South Pacific 457
XXXVII.	<i>Gephyrea</i> from Rotuma and Funafuti 468
XXXVIII.	Fig. 1. <i>Phrynobatrachus perpalmatus</i> . Fig. 2. <i>Ar-</i> <i>throleptis moorii</i> . Fig. 3. <i>Phrynixalus oxyrhinus</i> . Fig. 4. <i>Mantophryne robusta</i> } 473
XXXIX.	Fig. 1. <i>Hylodes alfredi</i> . Fig. 2. <i>Borborocates mexi-</i> <i>canus</i> . Fig. 3. <i>Hyla microcephala</i> . Fig. 4. <i>Hyla</i> <i>fallax</i> }
XL.	<i>Molge italica</i> 482
XLI.	} British-East-African Arachnida 497
XLII.	
XLIII.	} Corals from the South Pacific 525
XLIV.	
XLV.	} Plankton of the Faeroe Channel 550
XLVI.	
XLVII.	} <i>Cercopithecus thoeesti</i> , ♀ 586
XLVIII.	
XLIX.	} <i>Pyralidæ</i> of the Subfamily <i>Pyraustinæ</i> 590
L.	
LI.	Sciagraph of <i>Gnathonemus rhynchophorus</i> 775
LII.	} Holothurians from Funafuti and Rotuma 834
LIII.	
LIV.	New Spiders from Trinidad, W.I. 890
LV.	Fig. 1. <i>Phyllodactylus siamensis</i> . Fig. 2. <i>Anolis</i> <i>curtus</i> . Fig. 3. <i>Arthroseps weneri</i> . Fig. 4. <i>Lygosoma alfredi</i> } 912
LVI.	Fig. 1. <i>Diploglossus nuchalis</i> . Fig. 2. <i>Varamus</i> <i>brevicauda</i> }
LVII.	Fig. 1. <i>Lygosoma aignanum</i> . Fig. 2. <i>L. gastrostigma</i> }
LVIII.	Tarsi of <i>Blattidæ</i> 924

Plate	Page
LIX. Osteology of the Impennes.—Fig. 1. <i>Spheniscus magelanicus</i> . Fig. 2. <i>Pygoscelis papua</i> . Fig. 3. <i>Aptenodytes patagonica</i> . Fig. 4. <i>Eudyptula albosignata</i> . Fig. 5. <i>Catarrhactes chrysocome</i>	} 958
LX. Osteology of the Impennes.—Fig. 1. <i>Eudyptula albosignata</i> . Fig. 2. <i>Catarrhactes chrysocome</i> . Fig. 3. <i>Megadyptes antipodum</i>	} 958
LXI. Osteology of the Impennes.—Figs. 1, 4, 5. <i>Catarrhactes chrysocome</i> . Figs. 2, 3. <i>Pygoscelis papua</i> .	} 994
LXII. Corals from the South Pacific	994
LXIII. }	
LXIV. } Macrura from the South Pacific	1000
LXV. }	
LXVI. Plankton of the Faeroe Channel	1016

LIST OF ILLUSTRATIONS IN THE TEXT.

1898.

	Page
<i>Lepidosiren</i> , Views of dry-season burrows of, as seen in section . .	42, 43
<i>Scythrops</i> , Skull of, ventral view	47
<i>Eudynamis</i> , Skull of	49
<i>Scythrops</i> , Skull of, lateral view	49
<i>Eudynamis</i> , Skull of, lateral view	49
<i>Pteropus medius</i> , Heart and lungs of, seen from the ventral aspect. .	63
<i>Pteropus medius</i> , Heart and lungs of, dorsal aspect	64
<i>Pteropus edulis</i> , Heart of, ventral surface	65
<i>Pteropus medius</i> , Heart of, dorsal surface	66
<i>Pteropus edulis</i> , Heart of, with portion of wall of right ventricle turned back	68
<i>Pteropus edulis</i> , Heart of, with right auricle opened and wall of right ventricle removed	68
<i>Pteropus</i> , Internal Mammary Arteries and Veins of, from the dorsal aspect	71
<i>Phaëthon flavirostris</i> , Sternum of, left side view	87
<i>Phalacrocorax carbo</i> , Sternum of, left side view	88
<i>Phalacrocorax carbo</i> , Dorsal aspect of the pelvis of	88
<i>Phaëthon flavirostris</i> (nestling), Dorsal aspect of the pelvis of	89
<i>Phaëthon flavirostris</i> , Anterior aspect of the proximal end of the humerus of	90
<i>Pelecanus rufescens</i> , Anterior aspect of the proximal end of the humerus of	90
<i>Phalacrocorax carbo</i> , Anterior aspect of the proximal end of the humerus of	90
<i>Steganopodes</i> , Diagram showing the probable relationships between the various families of the Suborder	92
<i>Alytes obstetricans</i> , Skeleton of regenerated left hind limbs of	103
<i>Alytes obstetricans</i> , Outlines of developing hind limbs (normal) of. .	104
Falconets, The White-legged	128
<i>Bassariscus astutus</i> , Brain of	130
<i>Canis familiaris</i> , External muscles of thigh of	156
<i>Herpestes</i> , Inside view of thigh-muscles of	161
<i>Herpestes</i> , Muscles of hind foot of (dorsal view)	166
<i>Herpestes</i> , Plantar tendons of foot of	170
<i>Procyon</i> , Plantar muscles of foot of	173
<i>Lutra</i> , Muscles of sole of foot of	174
Ox (<i>Galla</i>), Horns of	203

	Page
<i>Lophomonas sulcata</i>	243
<i>Lophomonas sulcata</i> , Possible cyst of	244
Dragonets, Male and female, preparing to ascend, and bundle of prismatic bodies	289
Dragonets, Male and female, in coition	290
<i>Oreas derbianus</i> , Horns of	349
<i>Perichæta cupulifera</i> , Ventral view of XVIIIth segment of	446
<i>Perichæta crescentica</i> , Spermatheca from VIIIth segment, right side, of	448
<i>Gnaphosa molesta</i> : epigyne	489
<i>Gnaphosa molesta</i> : eyes from above and a little behind	489
<i>Lycosa riparia</i> : epigyne	490
<i>Lycosa riparia</i> : portion of palpus and palpal organs	490
Tow-net, Mid-water	569, 572
<i>Orthoraphis obfuscata</i> , ♂	604
<i>Neurophyseta clymenalis</i> , ♂	605
<i>Psephis myrmidonalis</i> , ♂	605
<i>Gonodiscus amplalis</i> , ♂	606
<i>Homophysa glaphyralis</i> , ♂	607
<i>Scybalista bifascialis</i> , ♂	608
<i>Symphysa sulphuralis</i> , ♂	609
<i>Monocoptopera ecmetallescens</i> , ♂	610
<i>Voliba scoparialis</i> , ♂	611
<i>Lipocosma sicalis</i> , ♂	611
<i>Catapsephis apicipuncta</i> , ♂	612
<i>Sufetula sunidesalis</i> , ♂	613
<i>Erpis macularis</i> , ♂	614
<i>Massepha absolutalis</i> , ♂	615
<i>Aulacoptera fuscinervalis</i> , ♂	617
<i>Xanthomelena schematias</i> , ♂	617
<i>Rhimphaleodes macrostigma</i> , ♂	618
<i>Entephria jaguaralis</i> , ♂	619
<i>Ravanoa xiphialis</i> , ♂	622
<i>Rehimena striolalis</i> , ♂	622
<i>Zinckenia fascialis</i> , ♂	623
<i>Tabidia aculealis</i> , ♂	624
<i>Eurrhyparodes bracteolalis</i> , ♀	625
<i>Heterocnephes lymphatalis</i> , ♂	627
<i>Agroptera magnificalis</i> , ♂	628
<i>Desmia funeralis</i> , ♂	630
<i>Ætholix flavibasalis</i> , ♂	634
<i>Pagyda salvalis</i> , ♂	634
<i>Ercta elutalis</i> , ♂	637
<i>Cnaphalocrocis medinalis</i> , ♂	638
<i>Marasmia veniialis</i> , ♂	638
<i>Rhimphalea trogusalis</i> , ♂	640
<i>Hyalea dividalis</i> , ♂	641
<i>Leucochroma corope</i> , ♂	642
<i>Syngamia floridalis</i> , ♂	643

	Page
<i>Hyleithia decostalis</i> , ♂	646
<i>Samea ecclesialis</i> , ♂	647
<i>Trithyris scyllalis</i> , ♂	648
<i>Bocchoris onychinulis</i> , ♂	650
<i>Salbiomorpha torsalis</i> , ♂	654
<i>Pilocrocis ramentalis</i> , ♂	655
<i>Ulopeza idyalis</i> , ♂	660
<i>Nosophora althealis</i> , ♂	661
<i>Chalcidoptera emissalis</i> , ♂	664
<i>Mesocondyla dardusalis</i> , ♂	666
<i>Leucophotis pulchra</i> , ♂	667
<i>Caprinia conchylalis</i> , ♂	668
<i>Spilomela perspicata</i> , ♂	669
<i>Macaretæra hesperis</i> , ♂	669
<i>Acridura gryllina</i> , ♂	670
<i>Filodes fulvidorsalis</i> , ♂	671
<i>Tyspanodes fascialis</i> , ♂	673
<i>Conchylodes diptheralis</i> , ♂	674
<i>Nevrina procopia</i> , ♂	676
<i>Dichogama redtenbacheri</i> , ♂	676
<i>Phryganodes noctescens</i> , ♂	677
<i>Proconica nigrocyanalis</i> , ♂	687
<i>Oligocentris deciusalis</i> , ♂	687
<i>Dichocrocis punctiferalis</i> , ♂	688
<i>Nacoleia pæonalis</i> , ♂	694
<i>Goniorhynchus plumbeizonalis</i> , ♂	704
<i>Erinothus lollialis</i> , ♂	706
<i>Achantodes cerusicosta</i> , ♂	707
<i>Pileosoma novalis</i> , ♂	707
<i>Deba surrectalis</i> , ♂	708
<i>Ceratarcha umbrosa</i> , ♂	709
<i>Botyodes asialis</i> , ♂	709
<i>Authæretis eridora</i> , ♂	711
<i>Prorodes mimica</i> , ♂	711
<i>Sylepta sellalis</i> , ♂	712
<i>Endographis acrochlora</i> , ♂	726
<i>Lygropia quaternalis</i> , ♂	726
<i>Agathodes ostentalis</i> , ♂	730
<i>Glyphodes bivitralis</i> , ♂	731
<i>Cliniodes opalalis</i> , ♂	748
<i>Pygospila costiflexalis</i> , ♂	749
<i>Heortia vitessoides</i> , ♂	751
<i>Euclasta defamatalis</i> , ♂	751
<i>Polythlipta cerealis</i> , ♂	752
<i>Lephyrodes pueritia</i> , ♂	753
<i>Syllepsis marialis</i> , ♂	754
<i>Analyta singularis</i> , ♂	755
<i>Leucinodes orbonalis</i> , ♂	756

	Page
<i>Metrea ostreonalis</i> , ♂	757
<i>Crocidolomia suffusalis</i> , ♂	758
<i>Ommatospila descriptalis</i> , ♂	759
<i>Hellula undalis</i> , ♂	760
<i>Pseudocucumis</i> , Diagram of oral tentacles of	844
Pirisál at Dunas, Marajó	854
<i>Lepidosiren</i> , Head of living, showing the ramifications of the fore- limb	855
<i>Lepidosiren</i> , Head of living, on the left side	855
<i>Pedetes caffer</i> , Dorsal view of carpus of	863
<i>Pedetes</i> , Forearm of	867
<i>Pedetes</i> , The Panniculus of	868
<i>Pedetes</i> , Inner view of wall of pelvis of	870
<i>Pedetes</i> , Knee-joint of, with the femur removed	875
<i>Pedetes</i> , Knee-joint of, from behind	876
<i>Pedetes</i> , Inner view of ankle and foot of	877
<i>Pedetes</i> , Palate of	879
<i>Pedetes</i> , Digestive organs of	879
<i>Pedetes</i> , Cæcum of, viewed from behind	880
<i>Pedetes</i> , Under surface of liver of	881
<i>Pedetes</i> , Heart of, with right auricle opened from in front	884
<i>Catarrhactes chrysocome</i> , Lateral view of the innominate of a nestling, to show the separate elements	979
<i>Spheniscidæ</i> , Diagram showing the probable relationships of the various genera of the family	981
Apes, Outline tracings of the heads of various	991
Faeroe Channel, Chart of the	1017

LIST OF NEW GENERIC TERMS.

1898.

	Page		Page
Aclonophlebia (Lep.)	428	Leptomyrina (Lep.)	405
Aëthurus (Mamm.)	450	Metabetaeus (Crustacea)	1014
Arthroseps (Rept.)	920	Metaculasta (Lep.)	444
Bathybates (Pisces).....	495	Monocoptera (Lep.) ...	596, 610
Bettonia (Lep.)	418	Perissodus (Pisces)	496
Catapsephis (Lep.)	594, 612	Petrochromis (Pisces)	496
Cheiridisia (Coleopt.)	226	Piletosoma (Lep.)	595, 707
Chromidotilapia (Pisces)	151	Pisenorodes (Arachn.).....	504
Ectodus (Pisces)	497	Plecodus (Pisces)	497
Eretmodus (Pisces).....	495	Proconica (Lep.)	598, 686
Erinothus (Lep.)	595, 706	Pseudedusia (Coleopt.)	229
Eucratoscelus (Arachn.)	500	Simochromis (Pisces)	496
Geatractus (Rept.)	539	Symphysa (Lep.)	594, 609
Hameopis (Lep.)	435	Tarsocera (Lep.)	903
Julidochromis (Pisces)	495	Telmatochromis (Pisces)	495
Lembopteris (Lep.).....	438	Torynesis (Lep.)	903
		Tropheus (Pisces)	496
		Trotonotus (Lep.)	431

ERRATUM AND ADDENDUM.

P. 486, 6th line from top, for 'Taranto' read 'Otranto.'

P. 487, add EXPLANATION OF PLATE XL.

The largest specimen, upper, lower, and side views, represents a breeding female of *Molge italica*, the others breeding males. The skull on the right hand is that of *M. italica*, the one on the left is that of *M. vulgaris* var. *meridionalis*, both enlarged two diameters. The outline figures between the skulls represent sections of the body of *M. italica*, ♂ (lower figure), and *M. vulgaris* var. *meridionalis*, ♂ (upper figure).

PROCEEDINGS
OF THE
GENERAL MEETINGS FOR SCIENTIFIC BUSINESS
OF THE
ZOOLOGICAL SOCIETY OF LONDON.

January 18, 1898.

Dr. A. GÜNTHER, F.R.S., Vice-President, in the Chair.

The Secretary read the following report on the additions to the Society's Menagerie during the month of December 1897 :—

The total number of registered additions to the Society's Menagerie during the month of December was 79, of which 45 were by presentation, 18 by purchase, 15 were received on deposit, and one was born in the Menagerie. The total number of departures during the same period, by death and removals, was 154.

Amongst these attention may be called to :—

1. Two White-naped Weasels (*Pœcilogale albinucha*)¹ from Natal, presented by Mr. William Champion, F.Z.S., Dec. 1st. This curiously marked Weasel, which much resembles a Zorilla in its markings (see P. Z. S. 1864, p. 69, pl. x.), is new to the Collection.

2. A specimen of an apparently new species of Wild Cat from Foochow, China, presented by Messrs. Rickett and J. La Touche of that Port, and received December 6th, for which I propose to adopt (at all events for the present) Mr. La Touche's suggested

¹ Cf. Thomas, Ann. N. H. (5) xi. p. 370 (1883).

name of *Felis dominicanorum*, after the Dominican Monks from whom he received the specimen.

I exhibit a coloured drawing by Mr. Smit of this animal (Plate I.), and read an extract from a letter of Mr. La Touche's to Mr. Thomas relating to it (dated Foochow, 10. viii. 97):—

“I have lately acquired a wild cat which I suspect to be new. This cat was obtained at Kuatun last winter, and sold to one of the Spanish Missionaries, who kept it for several months and who eventually sent it to me. It would appear to resemble *Felis temmincki* of India, but differs in some ways so far as I can see. The animal is of somewhat cross disposition, and won't bear too close inspection. In size it would seem to be about 3 ft. from head to root of tail. The tail is long and of uniform width, perhaps may measure 20 inches. The height at shoulders is quite 18 inches. The marks on the face answer to those given in the description of *F. temmincki*; the chin is white, breast dirty white with not well-marked stripes; ears black outside with paler centres. The general colour is a reddish brown; the hair would appear to be grey at base, brown in the centre, and tipped with grey or whitish, which gives the beast a greyish-brown appearance. The tail is, I believe, darker at tip and buff underneath. The nose is dull red, and the iris a brownish yellow, pupil round or nearly so.”

3. Two White-legged Falconets (*Microhierax melanoleucus*), presented by the same gentleman at the same date, being the first examples of this diminutive Bird of Prey received by the Society.

4. A Lucan's Crested Eagle (*Lophotriorchis lucani*) from West Africa, presented by Dr. H. O. Forbes on December 18th. This rare Bird of Prey, originally based by Messrs. R. B. Sharpe and A. Bouvier (Bull. Soc. Zool. France, ii. p. 471, 1877) on an example from French Congoland, is new to the Society's Collection.

5. A young Bear presented by Mr. William Crosley on the 28th December, which I have not been able to determine satisfactorily. As will be seen by its skin which I now exhibit, it does not show the characteristic markings of *Ursus ornatus*, the generally known Bear of the South-American Andes, being of a uniform black with a slight greyish-white patch on the throat. It may possibly be the young of a different species from the Colombian Andes, and in such case may be referable to that which I shortly described before this Society in 1868 (P. Z. S. 1868, p. 73, pl. viii.) as *Ursus nasutus*. Mr. Crosley has kindly supplied me with the following note on the exact locality of this specimen, which it is proposed to deposit in the British Museum:—

“The little Bear I sent to you came from the banks of the Simitara, an affluent of the Magdalena on the western side. You will see that this is on the eastern slope of the Central chain of the Andes in their northern extremity.

“Approximately you may fix the position as 7° 30' North latitude and 74° West of Greenwich long., on the meridian of Bogotá more or less.”





Dr. Forbes has also kindly sent us seven examples of the celebrated Walking-Fish of the West Coast of Africa (*Periophthalmus boelreuteri*), which, however, we have unfortunately not been able to keep alive.

On behalf of Dr. R. Collett, of Christiania, F.M.Z.S., the Secretary exhibited a mounted specimen of a bird obtained in Norway, and believed to be a hybrid between the Fieldfare (*Turdus pilaris*) and the Redwing (*T. iliacus*). It was intermediate in size and colour between these two species.

Mr. W. E. de Winton exhibited the skin of a Zebra, obtained by Mr. S. L. Hinde near Machakos, British East Africa, of the form described by Dr. Matschie as *Equus boehmi* (S.B. Ges. naturf. Fr. Berlin, 1892, p. 131). The only specimens from Brit. E. Africa hitherto received by the British Museum had been obtained by Dr. Gregory on the Thika Thika River, one of the headwaters of the Tana R., this form being named *E. burchelli granti* De Winton (Ann. Mag. N. H. 1896, xvii. p. 319). The form *E. b. boehmi* might readily be distinguished from *E. b. granti* by the presence of well-marked shadow-stripes upon the haunches, the body-markings generally being of much the same character and proportions as those of the Zebra of Mashonaland, *E. b. selousi* Pocock (Ann. Mag. N. H. 1897, xx. p. 45); but the feet of the present specimen being wanting, it was impossible to compare the pasterns; the dorsal stripe in this single specimen, from the saddle backwards, was not separated from the side-stripes by distinct white spaces as in the specimens from the Tana R., but how far this character would be found constant could not now be determined.

Mr. Hinde was of opinion that the two forms occur in separate herds in country not geographically separate but of different characters: one keeping to open plains, the other living in bush-country. Be this as it may, it was of very great interest to have undoubted evidence of these two apparently distinct forms occurring so close together, Dr. Matschie having described his species from a sketch of an animal from the neighbourhood of Kilimanjaro and from a living specimen in the Zoological Gardens at Berlin of doubtful origin.

It might be hoped that other specimens, with careful data recorded, would be brought home when it was realized how badly skins are wanted, and how little is known of the distribution and habits of these interesting animals.

The following papers were read:—

1. On the Development of the Hyobranchial Skeleton of the Midwife-Toad (*Alytes obstetricans*). By W. G. RIDEWOOD, D.Sc., F.L.S., Lecturer on Biology at St. Mary's Hospital Medical School, London.

[Received November 15, 1897.]

(Plate II.)

The object of the present investigation was to ascertain how far the peculiarities of the hyobranchial development of *Pelodytes*, already detailed in the Proceedings of this Society (9), are to be considered normal for phaneroglossal Anura generally. The adult hyobranchial skeleton of *Pelodytes* is so aberrant in structure that it is natural to suspect that the mode of development of the parts may not conform very closely with that of a more generalized type of Anuran. Since the arciferous type of shoulder-girdle, the presence of free ribs, the frequent persistence of postcardinal veins, and the primitive nature of the carpus and tarsus show *Alytes* to be one of the most lowly organized of the Anurous Batrachians, and in consideration of the larger size of the tadpoles of this genus as compared with those of the otherwise equally suitable genus *Discoglossus*, *Alytes* was chosen to supply the test.

The material for the investigation was, as before, generously provided by Mr. G. A. Boulenger, F.R.S., of the Natural History Museum, London. Twenty-one specimens were dissected, and from these the eight here described and figured were so selected as to exhibit the most even gradations from the youngest stage to the adult condition. The stages are numbered 1–8 to distinguish the order in which they succeed one another; but the use of these figures does not imply correspondence with any stage bearing a similar number in the previous descriptions of the hyobranchial skeleton of *Xenopus*, *Pipa* (8), and *Pelodytes* (9). In order to facilitate comparison the figures are not drawn to the same scale, but as nearly as possible of the same absolute size. The approximate magnification is given in each case. Figures 1–7 exhibit the dorsal surface of the hyobranchial skeleton, but fig. 8, of the adult, is drawn from the ventral surface, so that the ventral splint-bone may be more clearly seen. The method of procedure was the same as in the two earlier investigations; and as the nomenclature of parts adopted in this paper is the same as that previously employed in the description of the hyobranchial apparatus of *Pelodytes*, a lengthy introduction is here unnecessary,

The adult skeleton of *Alytes* (Plate II. fig. 8) is not very remarkable. The hyoidean cornua (*h*) are thin and continuous, but rather more flattened than in the Common Frog. The posterior cornua or thyrohyals (*t*) are normal, and in the middle of the ventral surface of the body of the hyoid is a V-shaped

superficial bone (*v*) which is related to the hyoglossus muscle in the same way as the H-shaped splint-bone of *Pelodytes*. The antero-lateral or alary processes (*pal*) and the postero-lateral processes (*ppl*) are feebly developed, but they are hardly so reduced in size as to justify the statement by Stannius (10. p. 65, footnote): "bei Alytes ist, statt zweier Seitenfortsätze, jederseits eine breite Platte vorhanden."

Of the published figures of the hyoid skeleton of *Alytes*, that by Parker (7. pl. 24, fig. 4) is the most reliable. This author regards the splint-bone as an ectosteal basibranchial (p. 134), and describes (p. 133) the hyoidean cornua as having small hypohyal lobes (= proc. ant. 9. p. 589), lobes which I find to be altogether wanting in the Discoglossid genera *Alytes*, *Discoglossus*, and *Bombinator*. The much earlier figure of Henle's (5. pl. 2, fig. 24), reproduced by Hoffmann in the 'Klassen und Ordnungen des Thierreichs' (6. pl. 46, fig. 24), is not much inferior to that of Parker's; but the one given by Dugès (2. pl. 3, fig. 20) is decidedly poor. Only the proximal ends of the hyoidean cornua are shown, and the lateral parts of the basal plate are represented in the figure, and described in the text (2. p. 56), as ossified in the same manner as in *Bombinator*. Cope (1. pl. 76, fig. 3) endeavoured to compromise matters by combining the figures of Dugès and Parker, from which fact it is evident that he had never seen the hyoid of *Alytes*, or he would have rejected Dugès's figure entirely. The statement by Cope (1. p. 234) that "sometimes the third ceratobranchial is ossified, as in *Alytes* (pl. 76, fig. 2)," involves a confusion of *Alytes* with *Bombinator*, for the figure referred to is that of the latter genus. The statement would, however, in neither case be correct.

STAGE 1. *Specimen measuring from snout to root of tail 20 mm. Length of tail 40 mm. Length of hind limb 2 mm. (Plate II. fig. 1.)*

The ceratohyals (*ch*) are broad and flat at their mesial ends, while their lateral extremities bear each a convex surface for articulation with the palatoquadrate cartilage and a terminal process for muscular attachment. They are not in contact with one another in the median line, but between them occur first an elliptical cartilage, the anterior copula (*ca*), then a space, then a fibrous mass, the "pars reuniens" (*pr*), and finally a posterior copula (*cp*) of larger size than the first. The postero-internal edges of the ceratohyals abut on the hypobranchial cartilages (*hb*). The anterior copula ("erste Copula" of Gaupp, 3. pp. 411 and 412, to whom the discovery of this cartilage is due¹) is elliptical in shape, the long axis of the ellipse being disposed at

¹ Götte (4. pl. 18, fig. 332) gives a figure of the larval hyobranchial skeleton of *Bombinator* showing three axial structures which probably represent the first and second copulae, with the pars reuniens between. The relations, however, are not clearly indicated, and no special description is given of these parts in the text, so that the credit of the discovery of an anterior copula in Anuran tadpoles must be accorded to Gaupp.

right angles to the length of the body. It is united by fibrous tissue with the ceratohyal of each side, and is separated from the pars reuniens by a space or foramen. This latter is closed by loose connective tissue, and must not be confounded with the hyoglossal foramen of the aglossal Toads, transmitting the hyoglossus muscle. The pars reuniens is a dense mass of whitish fibrous tissue, with a straight anterior edge, slightly convex lateral margins, and a notched posterior border. It is slightly broader than long, and serves to bind the ceratohyals together. The second mesial cartilage, the posterior copula, corresponding with what was called "basihyal" in *Pelodytes* (9. p. 583), is much larger than the first. It is pentagonal in shape and considerably longer than broad. The pointed anterior end can be traced on the ventral surface of the pars reuniens, reaching as far forward as the foramen above mentioned, so that the length of the cartilage is greater than appears in a dorsal view. The antero-lateral edges abut on the ceratohyals, the lateral edges on the hypobranchial plates, while the posterior and smallest edge forms the anterior boundary of the laryngeal sinus. This complete separation of the hypobranchial plates by the second copula, which, like the presence of the anterior copula, is, I believe, peculiar to the Discoglossidæ, was incidentally referred to in my previous contribution (9. p. 581). There is in *Alytes* no triangular space on either side of the posterior copula such as occurs in *Pelodytes* (9. pl. 35, figs. 1, 2, and 3, s), *Pelobates*, and a great number of other genera.

The hypobranchial plates (*hb*) are approximately triangular in shape, and the posterior extremity of each bounds the laryngeal sinus laterally. The anterior angle runs up to the point where the ceratohyal and posterior copula touch one another, while the lateral angle is attached to the base of the first ceratobranchial (*cb* 1). The four branchial bars or ceratobranchials are united with one another at their proximal ends and at their distal ends. The last (*cb* 4) is the shortest and the broadest. The distal part of the third ceratobranchial is somewhat expanded, and is continued beyond the commissural cartilage into a pointed process which is much larger than those into which the ceratobranchials 1 and 2 are produced. There is no corresponding process to the fourth ceratobranchial. Five to eight warty outgrowths of cartilage occur on the anterior and posterior edges of the bars, but, while those on the posterior border of the fourth ceratobranchial are almost obsolete, those on the anterior border of the first ceratobranchial are greatly prolonged, so as to form a sort of palisade. There is a tendency for these latter processes to fuse in an irregular manner to form an anterior protective wall, as in *Pelodytes* (9. p. 584). Only three pairs of spicula are present. Those which constitute the free, recurved proximal ends of the third ceratobranchials are long (*sp* 3), but those of the second ceratobranchial are short and stunted. There are no spicula at all to the first ceratobranchial, and those of the fourth are continued back, as usual, over that posterior part of the

hypobranchial cartilage which will ultimately develop into the thyrohyal.

There is not the same continuity of ceratobranchial and hypobranchial cartilage as is found in *Pelodytes*; such coalescence, in fact, only occurs in the case of the fourth ceratobranchial. The third ceratobranchial is attached to the postero-lateral edge of the hypobranchial cartilage by fibrous tissue, while opposite to the place where the second ceratobranchial should be attached is a small foramen, the proximal end of the bar being kept in position only by its connections with the first and third ceratobranchials. Ceratobranchial 1 is attached by fibrous tissue to the lateral angle of the hypobranchial plate at some distance outward from the posterior cusp of the ceratohyal¹, and does not during later development become fused with it. There is thus an interesting difference between the relations of the proximal end of ceratobranchial 1 in *Alytes* and *Pelodytes*, for while in the latter genus it is fused with the hypobranchial cartilage and bound by connective tissue to the proximal end of ceratobranchial 2 (9. p. 584), in *Alytes* it is united with the hypobranchial by connective tissue and is fused with the end of the second ceratobranchial. The difference is important as well as interesting, inasmuch as the basal portion of the first ceratobranchial of *Pelodytes* can be clearly seen to persist as the postero-lateral process of the adult hyoid, while in *Alytes* the whole of the first ceratobranchial becomes absorbed, and the process of the hypobranchial cartilage to which it was attached broadens out into a plate from the edge of which the postero-lateral process (*ppl*) subsequently grows out (see figs. 5-7).

STAGE 2. *Specimen measuring 21 mm. from snout to root of tail. Length of tail 41 mm. Length of hind limb, extended, 19 mm. Fore limbs extruded and measuring 8 mm. when extended.* (Plate II. fig. 2.)

Although at this stage the tadpoles have four well-formed legs, and have shed their horny jaws, but slight changes have occurred in the hyobranchial skeleton. The ceratohyals are larger and slope a little more posteriorly than in the first stage. The front copula is still present, but is smaller in proportion to the adjacent parts. The width across the hyoid region is now equal to the width across the branchial, whereas in the first stage it was less. The first ceratobranchial exhibits a wrinkling at its distal end, the absorption of cartilage having already begun in this position; and the laryngeal sinus is larger than before.

¹ Herein probably lies the explanation of the view propounded by Gaupp in his paper on *Rana* (3. p. 403), that the part of the first branchial arch between the spiculum and the hypobranchial plate belongs to the latter cartilage rather than to the ceratobranchial. There is no indication of any separation of the cartilages in *Rana* tadpoles, but as this author had, judging by his remarks on page 411 of his treatise, already made an examination of the larval hyobranchial skeleton of *Alytes*, it is just possible that his determination was influenced by the division which in this genus occurs in the position in question. The division is no more present in *Pelodytes* than in *Rana*, whence my hesitation (9. p. 584, footnote 2) to accept Gaupp's theory.

STAGE 3. *Specimen measuring 19 mm. from snout to root of tail. Length of tail 29 mm. Length of hind limb, extended, 21 mm. Length of fore limb, extended, 10 mm. (Plate II. fig. 3.)*

The ceratohyals are more massive than before, and have acquired a distinct backward slope. Examined from the ventral surface, the two ceratohyals are seen to meet in the median line and to be overlapped (ventrally) by the tapering anterior end of the larger copula, although in the two preceding stages they were separated from one another by a distance equal to one-half of the total width of the pars reuniens. The pars reuniens itself is less conspicuous than before. The anterior copula has disappeared, and the hyoglossal sinus (*hgs*) thus makes its first appearance.

The posterior copula is now thicker than the hypobranchial plates; the two are flush above, but the copula projects ventrally. The future thyrohyals are assuming shape and are thicker than the surrounding cartilage. In fact, the cartilage immediately external to the middle part of the rod is already so much resorbed as to present an incipient foramen (*tf*), the "thyroid foramen" of the previous communication (9. p. 586). The fenestration does not begin exactly at the region of attachment of the thyroid bodies, but more posteriorly; the absorption, however, continues in a forward direction and also externally (see figs. 3 and 4). Since both the developing thyrohyals and the copula are thicker than the surrounding cartilage, the former appear to be processes of the latter, for the line of junction is no longer to be seen on the ventral surface, and is barely visible above.

Considerable reduction has occurred in the branchial skeleton, and it is chiefly this which is responsible for the new aspect which the whole hypobranchial skeleton has assumed. The ceratobranchials are not only thinner, but shorter than before, judging by the diminution in the length of the branchial clefts, so that a shrinkage of cartilage must occur as well as absorption, a fact already pointed out in the case of *Pipa* (8. p. 105) and *Pelodytes* (9. p. 588). The distal end of the first ceratobranchial has separated from its commissural cartilage, but the second and third clefts still remain enclosed. The spicula have practically disappeared, and the warty outgrowths on the ceratobranchials are mostly absorbed.

STAGE 4. *Specimen measuring 18 mm. from snout to cloaca. Tail reduced to 3 mm. Length of hind limb, extended, 21 mm. Length of fore limb, extended, 10 mm. (Plate II. fig. 4.)*

The hyoglossal sinus is wider than before, and the ceratohyals slope more backwardly and are much more slender, especially at their distal or posterior ends. Here the surfaces of articulation with the palatoquadrate cartilage are no longer distinguishable. The pars reuniens has entirely disappeared, and the two ceratohyals can, in a dorsal view, be seen to unite in the median line. In Stage 3 this was only visible ventrally. A central oval area is differentiating in the middle of the hypobranchial skeleton. Its outline, though faint and ill-defined in front, is sharply marked behind, and

is caused partly by the now indistinct lateral limits of the second copula, but mainly by the white fibrous tissue, from which the ventral splint-bone will later develop, showing through the thickness of the cartilage.

The absorption of cartilage in the hypobranchial plates has proceeded apace, and the thyroid foramina are now quite large crescentic spaces. One of the consequences of this absorption is that the lateral promontory of the hypobranchial plate to which the first ceratobranchial is attached now stands out boldly at right angles to the median plane. On the anterior edge of this process a new cartilage is developing. It is as yet distinct from the hypobranchial cartilage, but in Stage 7 it fuses on, and forms part at least of, the alary or antero-lateral process of the adult hyoid (see figs. 4-7). A pair of cartilages similarly placed are figured by Parker in the hyobranchial skeleton of a recently metamorphosed specimen of *Rana palustris* (7. pl. 5, fig. 9), but he speaks of them (p. 37) as "remains of the branchial pouches," a determination which their position shows to be untenable.

The absorption of hypobranchial cartilage by the enlargement of the thyroid foramina causes the ceratobranchials to be *drawn in*, so that the proximal ends of ceratobranchials 2 and 3, which in Stage 3 were in a line with the extremity of the thyrohyal and the proximal end of the first ceratobranchial, are now much closer to the middle line. This, of course, is partly to be accounted for by the growth in length of the thyrohyals. The general result is that a transverse line drawn through the posterior ends of the thyrohyals now passes behind the branchial skeleton, whereas in the preceding stage the line passed through it. The fourth ceratobranchial has almost disappeared, only its distal end, fused with the external edge of the posterior extremity of the thyrohyal, remaining.

STAGE 5. *Specimen measuring 17 mm. from snout to cloaca. Stump of tail 1 mm. Length of hind limb, extended, 23 mm. Length of fore limb, extended, 10 mm. (Plate II. fig. 5.)*

The ceratohyals are slightly longer than before and considerably thinner. The distal or posterior end is curved, and the part which forms the lateral boundary of the hyoglossal sinus is quite slender. The hyoglossal sinus itself is both broader and deeper. In Stage 4 the ceratohyals were in contact in the middle line, but they are now considerably separated, and the extent of their divarication is marked by two slight notches at the bottom of the hyoglossal sinus. There is evidently an absorption of cartilage taking place here, which causes the posterior copula to extend into the sinus. The side margins of the posterior copula are still to be seen, but since the fibrous predecessor of the ventral splint-bone underlies them, it is only possible to obtain convincing proof of the fact after removal of this superficial tissue. The lines run down to the antero-internal border of the thyroid foramen, and reach the hyoglossal sinus in front at the notches already indicated.

The new growth of cartilage (*c*) in front of the pointed lateral process of the hypobranchial plate is larger in size and has assumed a triangular shape. The thyrohyals are also larger and their posterior extremities are dilated. The thyroid foramen does not yet open, since the ceratobranchials, although separated from one another at their distal ends, remain connected proximally. These last remnants of the ceratobranchials are short and stunted, but, seeing how near to the completion of their metamorphosis larvæ with tail reduced to a mere knob must be, it is surprising that any branchial arches should be found at all. The first ceratobranchial is triangular in shape, but the other two are more rod-like. No trace of the fourth is now to be seen.

STAGE 6. *Specimen measuring 20 mm. from snout to cloaca. Stump of tail 1 mm. Length of hind limb, extended, 23 mm. Length of fore limb, extended, 11 mm. (Plate II. fig. 6.)*

The ceratohyals are more slender than in the previous stage, and are of more uniform diameter throughout. They are thinnest where they bound the hyoglossal sinus laterally. The sinus itself is much wider than before, but not appreciably deeper. A couple of slight notches in its border still serve to show how far the ceratohyal cartilage is now situated from the median line. The ceratobranchials have entirely gone, and the thyroid foramen has opened out into a sinus. The thyrohyal (*t*) is thus formed by the persistence and enlargement of that part of the hypobranchial plate of the larva which forms the inner boundary of the thyroid foramen. It is a matter of great satisfaction to me to be able by the results of the present investigation to confirm the view which I first propounded in the case of *Pipa* (8. p. 106), and subsequently upheld in my paper on *Pelodytes* (9. p. 586).

Since the first ceratobranchial has in all the earlier stages been distinguishable from the hypobranchial plate, and has now disappeared, it is evident that it cannot form any part of the postero-lateral process of the adult hyoid as it does in *Pelodytes*. It cannot even be said that the pointed process of the hypobranchial cartilage to which it was attached becomes the aforementioned process, since this broadens out and fuses with the autogenous cartilage marked *c* in fig. 6, and only differentiates into antero-lateral and postero-lateral processes later.

STAGE 7. *Completely metamorphosed specimen measuring 20 mm. from snout to cloaca. No trace of tail. Length of hind limb, extended, 23 mm. Length of fore limb, extended, 11 mm. (Plate II. fig. 7.)*

Although the specimens which form the basis of the descriptions of Stages 6 and 7 are hardly distinguishable by their external characters, it is evident from the hyobranchial skeleton that the one now under discussion is considerably the older. The cartilage is much bluer, and more transparent and hyaline, than in the preceding. The ossification of the thyrohyals is just beginning, a small differentiated tract being discernible in the middle part of

the rod. The ventral splint-bone has also begun to ossify. The ceratohyal is extremely slender and delicately curved; its thickest part lies just external to the body of the hyoid. The notches in the hyoglossal sinus have disappeared, so that it is now impossible to define the limits of the posterior copula and the ceratohyal cartilage. The pointed lateral process of the hypobranchial plate is no longer distinguishable as such, but has broadened out into a plate. The antero-lateral (*pal*) and postero-lateral (*ppl*) processes are already disposed as in the adult. Both are evidently secondary outgrowths, as Gaupp (3. p. 433 (4)) has already shown to be the case in *Rana*. The antero-lateral process is probably formed in great measure by the independent cartilages (*c*, fig. 6), which remained free until the present stage.

STAGE 8. *Adult specimen measuring 33 mm. from snout to cloaca. Length of hind limb, extended, 46 mm. Length of fore limb, extended, 20 mm. (Plate II. fig. 8.)*

It is surprising how slight are the differences between the hypobranchial skeleton of the just metamorphosed animal and that of the fully-grown adult. The hyoglossal sinus has deepened considerably, so that it is now behind the antero-lateral sinuses, instead of being at the same transverse level with them as in Stage 7. The broadest part of the ceratohyal lies, as in Stage 7, just off the antero-lateral process. The ventral splint-bone is completely ossified, but the ossification does not extend into the subjacent cartilage. The bone is quite superficial, and can readily be dissected off. The thyrohyals are well ossified, the posterior extremities remaining cartilaginous and boot-shaped.

SUMMARY.

In the hypobranchial skeleton of the early larva of *Alytes* there is an anterior copula which subsequently disappears and forms no part of the adult hyoid.

The posterior copula extends backward to the laryngeal sinus, and thus completely separates the two hypobranchial plates. It persists as the central part of the body of the hyoid.

The postero-lateral process of the adult hyoid cannot be identified with the base of the first ceratobranchial as it can in *Pelodytes*, but both the antero-lateral and postero-lateral processes are new formations, as in *Rana*.

The branchial bars or ceratobranchials of the larva form no part of the adult hyoid, but are entirely resorbed.

The thyrohyal is developed from that part of the hypobranchial cartilage of the larva which constitutes the inner boundary of the thyroid foramen.

LIST OF AUTHORITIES REFERRED TO.

(A more complete bibliography on the Hyobranchial Skeleton of Anura will be found in papers 8 and 9 of the following list.)

1. COPE, E. D.—“Batrachia of North America.” Bull. United States National Museum, No. 34, 1889.

2. DUGÈS, A.—“Recherches sur l'Ostéologie et la Myologie des Batraciens.” Mém. (des savans étrangers) de l'Acad. des Sci., t. vi., Paris, 1835, pp. 1-216.
3. GAUPP, E.—“Beiträge zur Morphologie des Schädels. II. Das Hyo-Branchial-Skelett der Anuren und seine Umwandlung.” Morph. Arbeiten (Schwalbe), Bd. iii. Heft 3, Jena, 1894, pp. 399-438.
4. GÖTTE, A.—Die Entwicklungsgeschichte der Unke. Leipzig, 1875.
5. HENLE, D. J.—Beschreibung des Kehlkopfs. Leipzig, 1839.
6. HOFFMANN, C. K.—Klassen und Ordnungen des Thierreichs (Bronn): Amphibien, Bd. vi. Abth. 2. Leipzig und Heidelberg, 1873-78.
7. PARKER, W. K.—“On the Structure and Development of the Skull in the Batrachia. Part III.” Phil. Trans. Roy. Soc., vol. 172, London, 1881 (1882).
8. RIDWOOD, W. G.—“On the Structure and Development of the Hyobranchial Skeleton and Larynx in *Xenopus* and *Pipa*.” Journ. Linn. Soc. (Zool.), vol. xxvi., London, 1897, pp. 53-128.
9. RIDWOOD, W. G.—“On the Structure and Development of the Hyobranchial Skeleton of the Parsley-Frog (*Pelodytes punctatus*).” Proc. Zool. Soc. Lond., 1897, pp. 577-595.
10. STANNIUS, H.—Handbuch der Zootomie, Th. ii. Buch 2. Zootomie der Amphibien. Berlin, 1856.

EXPLANATION OF PLATE II.

Fig. 1. Hyobranchial skeleton of *Alytes obstetricans*. Stage 1, p. 5. Dorsal view. ($\times 4\frac{1}{2}$.)

2. Same. Stage 2, p. 7. Dorsal view. ($\times 4\frac{1}{2}$.)
3. Same. Stage 3, p. 8. Dorsal view. ($\times 5\frac{1}{4}$.)
4. Same. Stage 4, p. 8. Dorsal view. ($\times 5\frac{1}{2}$.)
5. Same. Stage 5, p. 9. Dorsal view. ($\times 5\frac{1}{2}$.)
6. Same. Stage 6, p. 10. Dorsal view. ($\times 7\frac{1}{2}$.)
7. Same. Stage 7, p. 10. Dorsal view. ($\times 7\frac{1}{2}$.)
8. Same. Stage 8, adult, p. 11. Ventral view. ($\times 4$.)

REFERENCE LETTERS.

- c.* Autogenous cartilages in figs. 4-6.
- ca.* Anterior copula.
- cb* 1. First ceratobranchial.
- cb* 4. Fourth ceratobranchial.
- ch.* Ceratohyal.
- cp.* Posterior copula.
- h.* Hyoidean cornu.
- hb.* Hyobranchial plate.
- hgs.* Hyoglossal sinus.
- ls.* Laryngeal sinus.
- pal.* Processus antero-lateralis.
- ppl.* Processus postero-lateralis.
- pr.* Pars reuniens.
- sp* 3. Cartilaginous spiculum of the third branchial arch.
- t.* Thyrohyal.
- tf.* Thyroid foramen.
- v.* Ventral splint-bone.

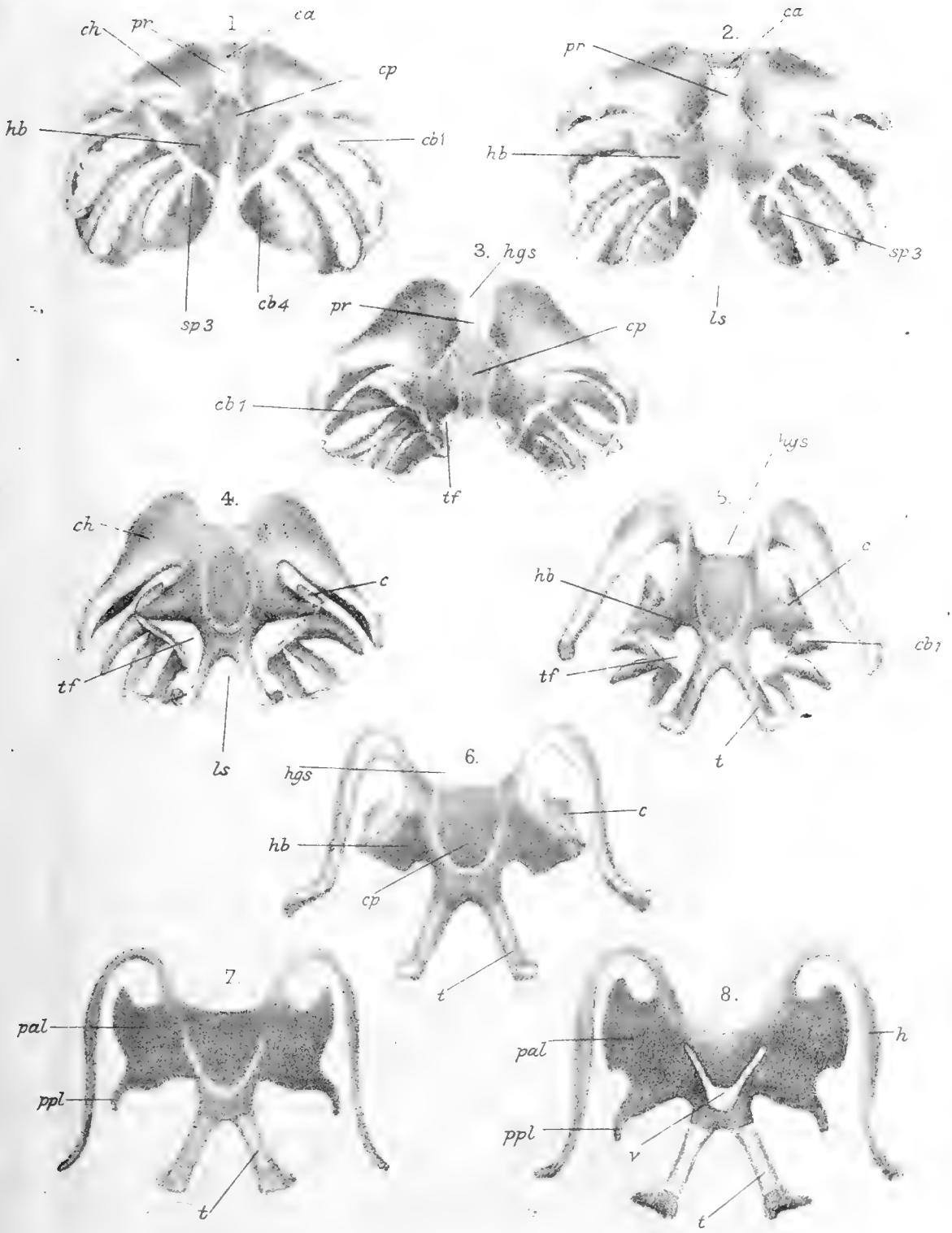

E. Drake, lith.

West, Newman imp.

Hyoid of *Alytes obstetricans*.



2. On the Cteniform Spiders of Africa, Arabia, and Syria.
By FREDK. O. PICKARD CAMBRIDGE, B.A.

[Received November 15, 1897.]

(Plates III. & IV.)

CONTENTS.

I. Two-clawed Cteniform Spiders.

- a. Introduction, p. 13.
- b. Bibliography, p. 13.
- c. List of Species already described, with Notes on their Identities,
p. 14.
- d. Descriptions of New Species, p. 20.

II. Three-clawed Cteniform Spiders.

- a. Introduction, p. 27.
- b. List of Species already described, with Notes on their Identities,
p. 28.
- c. Descriptions of New Species, p. 29.

I. a. *Introduction.*

The following pages include a note on every species belonging to the *Cteniform* Spiders which have been described from Africa and Western Asia, besides descriptions of eight new species of the two-clawed form and four of the three-clawed form. On page 351¹ of my paper on the *Ctenidæ* of Burmah I expressed myself as "satisfied that one cannot restore Thorell's genus *Dolopæus* for the Eastern Asiatic forms" of the three-clawed specimens. Since this was written, however, more material has come to hand, which enables me to reverse my decision in this respect. The following list contains the names of the new species described:—

- Ctenus johnstoni*, sp. n. Zomba, Lake Nyassa.
- „ *kingsleyi*, sp. n. Cameroons, W. Africa.
- „ *occidentalis*, sp. n. W. Africa.
- „ *spenceri*, sp. n. E. London, S. Africa.
- „ *carsoni*, sp. n. Tanganyika, &c.
- „ *burtoni*, sp. n. Cameroons, W. Africa.
- „ *marshalli*, sp. n. Umfuli River, S. Africa.
- „ *corniger*, sp. n. Natal, S. Africa.
- Thalassius jayakari*, sp. n. Muscat, Arabia.
- „ *cunningi*, sp. n. Fao, Persian Gulf.
- „ *hipsoni*, sp. n. Dorun, India.
- „ *spenceri*, sp. n. E. London, S. Africa.

I. b. *Bibliography.*

- 1833. M. PERTY. Del. Anim. Braz. (Spix and Martius). Brazil.
- 1837. C. A. WALCKENAER. Ins. Apt. i. p. 364. S. Africa.
- 1865. J. BLACKWALL. Ann. Mag. N. H. (3) xvi. p. 336. Africa.

¹ Ann. Mag. Nat. Hist. (6) xx. Oct, 1897.

1866. J. BLACKWALL. *Ann. Mag. N. H.* (3) xviii, p. 451. Africa.
 1872. O. PICKARD CAMBRIDGE. *Proc. Zool. Soc.* 1872, p. 320.
 Palestine.
 1873. E. GERSTÄCKER. *Von der Decken's Reisen in Ost-Africa*,
 iii, 2, p. 483. Africa.
 1875. L. KOCH. *Aegypt. und Abyssin. Araneiden*, p. 84. Egypt.
 1876. EUGÈNE SIMON. *Bull. Soc. Zool. Fr.* p. 222. R. Congo.
 1876. O. PICKARD CAMBRIDGE. *Proc. Zool. Soc.* 1876, p. 596.
 Egypt.
 1879. F. KARSCH. *Zeits. ges. Nat.* p. 347. W. Africa.
 1884. EUGÈNE SIMON. *Ann. Mus. Genov.* xx, p. 326.
 Egypt and Abyssinia, Congo, Cape of Good Hope.
 1885. EUGÈNE SIMON. *Bull. Soc. Zool. Fr.* p. 13. Africa.
 1886. H. LENZ. *Zool. Jahrbuch*, i, p. 379. Madagascar.
 1889. EUGÈNE SIMON. *Ann. Soc. Ent. Fr.* p. 233. Mazotte.
 1891. H. LENZ. *Jahrbuch Hamburg. Wissen. Anstalt*, ix, p. 170.
 Madagascar.
 1895. H. BÖSENBERG. *Jahrbuch Hamburg. Wissen. Anstalt*, xii,
 p. 12. East Africa.
 1896. EUGÈNE SIMON. *Ann. Soc. Ent. Fr.* lxxv, p. 465.
 1897 (Feb. 15th). EUGÈNE SIMON. *Hist. Nat. Ar.* éd. 2, tome ii,
 fasc. i, p. 104.
 1897 (Jan.). FREDK. CAMBRIDGE. *Ann. Mag. Nat. Hist.* (6) xix,
 p. 52.
 1897 (Oct.). FREDK. CAMBRIDGE. *Ann. Mag. Nat. Hist.* (6) xix,
 pp. 329-356.

I. c. *List of Species already described, with Notes on
 their Identities.*

1837. *Ctenus fimbriatus* Walck. *Insect. Apt.* i, p. 364. Cape of
 Good Hope.
 1865. *Ctenus velox* Blackw. *Ann. Mag. Nat. Hist.* (3) xvi, p. 336.
 Nyassa and Zambesi.
 1865. *Ctenus vividus* Blackw. *Ann. Mag. Nat. Hist.* (3) xvi,
 p. 336. Nyassa and Zambesi.
 1866. *Ctenus vagus* Blackw. *Ann. Mag. Nat. Hist.* (3) xviii,
 p. 451. Africa.
 1872. *Ctenus syriacus* Cambr. 'Spiders of Palestine,' p. 320.
 Jordan Plains.
 1875. *Ctenus pallidus* L. Koch. *Aegypt. u. Abyss. Ar.* p. 84,
 vii, 7. Habab, Egypt.
 1879. *Ctenus spinosissimus* Karsch. *Zeits. f. d. ges. Nat.* t. lii,
 p. 345. Congo.
 1884. *Ctenus torvus* Pav. *Ann. Mus. Genova*, xx, p. 74. Shoa.
 1896. *Ctenus modestus* E. Sim. Sub *Leptoctenus*. *Ann. Soc. Ent.*
Fr. lxxv, p. 492. Zanzibar, East Africa.
 1896. *Ctenus pulchrivertris* E. Sim. Sub *Leptoctenus*. *Ann. Soc.*
Ent. Fr. lxxv, p. 493. South Africa.
 1896. *Ctenus lycosinus* E. Sim. Sub *Leptoctenus*. *Ann. Soc. Ent.*
Fr. lxxv, p. 494. West Africa, Rio Pungo.

1896. *Ctenus aculeatus* E. Sim. Sub *Leptoctenus*. Ann. Soc. Ent. Fr. lxx. p. 494. West Africa, Rio Pungo.
1873. *Phoneutria decora* Gers. Von der Decken's 'Reisen in Ost-Africa,' iii. 2, p. 483, pl. viii. fig. 7. Mbaramu.
1876. *Phoneutria erythrochelis* E. Sim. Bull. Soc. Zool. Fr. i. p. 222. Landana, Congo.
1879. *Phoneutria auricularis* Karsch. Zeitschr. ges. Nat. p. 347. West Africa.
1879. *Phoneutria capulina* Karsch. Zeitschr. ges. Nat. p. 348. West Africa.
1886. *Phoneutria fasciata* Lenz. Zool. Jahrbuch, i. pp. 379-408. Isl. Nossi-Bé, Madagascar.
1895. *Phoneutria melanogastra* Bösenb. Jahrbuch Hamburg. Wissen. Anstalt, xii. p. 12 (sep. copy), t. i. f. 14-14 d. E. Africa.
1895. *Phoneutria debilis* Pav. Ann. Mus. Genova, xxxv. p. 523. Galla Country, East Africa.
1896. *Caloctenus guineensis* E. Sim. Ann. Soc. Ent. Fr. lxx. p. 496. Sierra Leone.
1896. *Anahita lineata* E. Sim. Ann. Soc. Ent. Fr. lxx. p. 497. Landana, Congo.
1896. *Anahita lurida* E. Sim. Ann. Soc. Ent. Fr. lxx. p. 497. Sierra Leone, Rio Pungo.

CTENUS FIMBRIATUS Walk.

♀. *Hab.* Cape of Good Hope.—This is a three-clawed form which has been selected by M. Simon as the type of *Thalassius* (*Titurius*), Sim.

CTENUS VELOX Bl. (Plate III. figs. 1, 2.)

♀. 20 mm. Adt. Type in coll. O. P. C. *Hab.* Zanzibar, S.E. Africa.

♀. Total length 20 mm. Cap. 10 × 8. Legs absent. Pat. + tib. i. 13—iv. 13·5. Prot. iv. 12·5.

Colour. Abdomen brown freckled with yellowish grey, with a broad dentated yellow band, bordered with black, along the dorsal area, comprising a longitudinal anterior yellow band. Ventral area black anteriorly, with two unequal white oval spots.

Structure. Eyes of second row straight; line passing through centres of centrals cuts posterior margin of laterals. Ocular quadrangle broader than long, broader behind. Eyes closer together, otherwise similar to those of allied forms.

The *vulva* consists of a long, dark, chitinous, raised, central tongue, dilate before the middle, slightly emarginate and again broadly dilate, depressed in front, convex in middle, again depressed behind; slightly but broadly grooved in centre longitudinally. Sides rugulose or impunctate, fringed with fine pale hairs. Posterior angles of tongue guarded on each side by a stout, slightly curved, blunt spur, black on margins, convex at apex, its

base set with a tuft of fine clustered pale hairs, curving inwards and backwards.

This form, of which two adult females remain, is obviously quite distinct from *C. vagus* and *C. vividus*, and from every other South-African forms which have come before me. I have taken this opportunity of redescribing and figuring the species, since the original descriptions are inadequate.

CTENUS VIVIDUS Bl.

♀ juv. 25 mm. Type in coll. O. P. C. *Hab.* S.E. Africa.

♀. Total length 25 mm. Cap. 13×10. Legs: i. 49—ii. 45, iii. —, iv. 49. Pat. + tib. i. 17—iii. 11, iv. 15. Prot. i. 11—iii. 8—iv. 8.

Colour. Carapace brown, with a broad yellowish-brown band (whose superior margin is somewhat dentated) extending along each side, and a narrow longitudinal one in the middle. Abdomen pale yellow, streaked and spotted with brown. A broad dentated, dull yellow band bordered with brown, and comprising a longitudinal row of brown spots, extends along the dorsal surface, and on each side is a series of brown spots.

Structure. Tib. i. and ii. with 2—2—2—2 spines beneath; one or two lateral external basal spines; one lateral internal basal spine. Patellæ i. and ii. sometimes with, sometimes without lateral spines, iii. and iv. with one small spine on each side. Prot. i. and ii. with 2—2—2 spines beneath, and a single small central apical spine beneath. *Eyes.* Second row almost straight by anterior margins, laterals slightly behind; otherwise the eye-formula is the same as in *C. vagus* Bl. Clypeus $1\frac{1}{2}$ diameters of anterior central eye.

Out of thirteen examples of this species from the relics of Mr. Blackwall's collection, there is not, unfortunately, a single adult specimen. Except in the difference in the height of the clypeus, and a slight difference in the curvature of the second row of eyes, these two forms, *C. vividus* and *C. vagus*, are exceedingly alike.

CTENUS VAGUS Bl.

♀ juv. 33 mm. Type in coll. O. P. C. *Hab.* Zambesi, S. Africa.

♀. Total length 33 mm. Cap. 16×12. Legs, i. 55—ii. 49·5—iii. 42—iv. 56. Pat. + tib. i. 19·5—iii. 13—iv. 17. Prot. i. 12—iv. 15.

Colour. The specimen being very old the colour is merely a uniform yellow-brown. Abdomen densely covered with brownish-yellow hairs, having a series of broad, curved, angular lines of a brown colour, with their convex sides towards each other and their vertices directed forwards.

Structure. Tib. i. and ii. with 2—2—2—2—2 spines beneath; 1—1 outside, lateral; 1 inside lateral, basal. Prot. i. and ii. with 2—2—2 spines beneath, and a single small central apical spine beneath. Patellæ i., ii., iii., and iv. with a single small spine on each side. *Eyes.* Second row straight by anterior margins; diameter of centrals more than three times transverse diameter of laterals.

Centrals $\frac{1}{2}$ diameter apart. Laterals 1 transverse diameter from centrals, over one transverse diameter from lateral posteriors. Diameter of lateral posteriors $\frac{1}{4}$ less than of central posteriors, one diameter from them. Ocular quadrangle broader than long, broader behind. Posterior $\frac{1}{3}$ larger than anteriors (by diameters). Anteriors $\frac{2}{3}$ diameter apart, $\frac{3}{4}$ a diameter from posteriors. Clypeus two diameters of anterior central eye. Inferior margin of fang-groove with four stout teeth, superior with three. Tarsals claws 2.

This fine Spider is unfortunately immature, but is obviously closely allied to the males taken in the Nyassan district of S.E. Africa, described below (p. 21) as *C. johnstoni*. The colours in the type specimen have faded, and I have therefore given the characters as described by Blackwall. I am indebted to the Rev. O. P. Cambridge for kindly allowing me to examine this and others of Blackwall's types.

CTENUS SYRIACUS O. P. Cambr.

♀ juv. 4.5 mm. *Hab.* Plains of Jordan. P. Z. S. 1872, p. 320.

There is no evidence from the description that this form belongs to *Thalassius* (*Titurius*), as Simon suggests. No mention being made of the number of subtibial spines or the number of tarsal claws or teeth on the fang-groove, it is impossible to gather to what genus it belongs.

Having carefully examined the type, however, there is no doubt that this form is two-clawed, with four teeth on the inferior margin of the fang-groove. The eye-formula is of the usual *ctenoid* character, and not that of *Thalassius*. Tibiæ i. and ii. with 2—2—2—2—2 spines beneath, the last pair not apical.

The type is, however, a very young female, and, further than that it belongs to one or other of the various subdivisions of the genus *Ctenus*, one cannot say anything more definite concerning it.

CTENUS PALLIDUS L. Koch. ♀.

Carap. 4 mm. Legs: i. 13 mm.—ii. 10.5 mm.—iii. 12.5 mm.—iv. 16 mm. *Hab.* Abyssinia.

“Die Beine 4.1.2.3.”—“Die beiden Klauen am Tarsus der ersten und zweiten Beinpaares mit je zwei kurzen Zähnen”—“dritten und vierten Paares—mit drei bis vier äusserst kleinen Zähnen.”—“Am vorderen Falzrande zwei, am hinteren sechs Zähne, die drei obersten der letzteren sehr klein.”—“Mit *Ctenus syriacus*, Cambr., ist *Ctenus pallidus* jedenfalls nahe verwandt, doch sind in der Farbe und Zeichnung so wesentliche Unterschiede vorhanden, das kaum angenommen werden kann, beide möchten eine und dieselbe Species sein.”

There appears to me to be no sufficient reason for regarding this form as congeneric with *Titurius* (*Thalassius*, Sim.), as Simon supposés, Ann. Mus. Genov. xx. p. 326.

CTENUS SPINOSISSIMUS Karsch.

Hab. Congo, W. Africa.

It is exceedingly difficult to grasp the characters from Dr. PROC. ZOOL. SOC.—1898, No. II. 2

Karsch's descriptions and figures, and one cannot therefore be sure of the identity of this species.

CTENUS TORVUS Pavesi.

♂ 16.5, ♀ 20 mm. Ann. Mus. Gen. xx. p. 74. Shoa, Abyssinia.

I have not seen this species, and cannot therefore give an opinion as to its affinities.

Cteni modestus, *pulchriventris*, *lycosinus*, and *aculeatus* are described by M. Simon under *Leptoctenus* from various regions of Africa. I have not had an opportunity of examining the types, but, so far as one can judge from the descriptions, they are not identical with any of those already described or now described in this paper as new.

PHONEUTRIA DECORA Gerst.

♀ 22 mm. Hab. Mbaramu, E. Africa.

"Brunnea, cervino-pubescentis, cephalothoracis linea media duplici flavescenti, regione ocellari falciumque basi ferrugineo-villosis: palporum basi coxisque rufescentibus, femoribus supra nigro-maculatis."

"Am Endrande mit vier scharfen Zähnen bewehrt."

Whether this description was taken from an adult it is difficult to say, but no description or figure is given of the vulva. It may be possible to identify the species when more material from Mbaramu comes to hand, but even then with no great certainty.

PHONEUTRIA ERYTHROCHELIS E. Sim.

♂, carap. 15. Hab. Landana, Congo, W. Africa.

♂. Carap. 15 × 11. Legs: i. 55—ii. 47.5—iii. 39—iv. 53.

"Brunnea, fulvo-pubescentis, cephalothoracis linea media et vittis marginalibus dilutioribus, chelis coccineo-pubescentibus, pedibus fulvis immaculatis."

"Chelicères noires, revêtues en avant, dans leurs deux tiers inférieurs, de pubescence serrée, d'un rouge vif."

"Pat. et tib. iv. plus longs que le céphalothorax; mét. iv. plus long que le tibia des deux tiers de la patella."—"Patte mâchoire de même teinte que les pattes. Tibia sensiblement plus long, plus étroit à la base, légèrement et graduellement élargi, pourvu d'une apophyse terminale externe, presque perpendiculaire, relativement grêle, simple et plus courte que le diamètre de l'article."

No mention is made of the palpal organs. Simon regards it as different from *C. velox* Bl. and *C. vividus* Bl., since the falces are in these species yellow, while those of *P. erythrochelis* are red. It differs from *P. decora* Gerst. in the absence of femoral spots. It is extremely possible that the species is quite distinct from the Nyassa District forms, but one cannot regard the description alone, without figures, as quite sufficient for purposes of identification.

It is not at all likely that this form should be the only one with red falces.

PHONEUTRIA AURICULARIS Karsch.

Hab. W. Africa.

It is impossible to say from the description what this may be.

PHONEUTRIA MELANOASTRA Bösenb.

♂ 11 mm., ♀ 16 mm. *Hab.* E. Africa. Types in coll. Nat. Hist. Mus. Hamburg, coll. Stuhlmann.—Jahrbuch der Hamb. Wiss. Anstalt, xii. p. 12, Taf. i. 14–14 *d.*

The figure given of the eyes is, I believe, drawn from a point more from above, and the second row thus appears more strongly recurved; whereas I should suspect (for I have not seen the type) that a line passing through the centres of the centrals would at most pass through the centres of the laterals, and in this case the second row would be absolutely straight. A young female now before me, taken in E. Africa at Likipia by Dr. Gregory, is very closely allied to *P. melanogaster*, if not identical. Being immature, however, one cannot pronounce on the point with any certainty.

There appears to me to be no necessity for separating these forms from the rest of the *Ctenidae*, other than in more or less well-defined groups.

Curiously enough, there is now also before me an adult female with black ventral band precisely similar to that of *P. melanogaster* and of the female from Likipia, with similar eye-formula, differing only in the absence of a lateral spine on tib. i. and ii. and the absence of spines on pat. i. and ii., from La Plata, Argentina, taken by Mrs. Oldfield Thomas.

The African and American forms resemble each other very closely, with certain minute though constant differences, such as an extra spine on the legs or an extra minute tooth on the fang-groove. Those from the Indian Archipelago and Australia approximate to a certain type only of those in Africa and America, of which *C. spenceri* is a fair representative from the former, and *C. albofasciatus* from the latter continent.

So far as the material at hand allows one to judge, the large Ctenoid forms represented by *C. reidyi*, *C. andrewsi*, and *C. boliviensis* in America, and *C. vividus*, *C. kingsleyi*, &c. in Africa, are absent from India, Burmah, the Indian Archipelago, and Australasia. But I am unable to satisfy myself, so far, that there is any distinction sufficiently pronounced to justify one in giving to these two different groups distinct generic names.

An adult male from Umfuli, taken by Mr. G. A. Marshall, is evidently very closely allied to *P. melanogaster* B., being apparently precisely similar in markings. The figure given of the palpus in "ostafrikanische Specimen" is scarcely sufficiently detailed to enable one to decide with certainty on the point. Herr Bösenberg has, however, with his usual generosity, furnished me with a beautiful enlarged drawing of this important organ, and I am now able to assert positively that *P. melanogaster* Bg. is quite distinct from *P. marshalli*, n. sp.

PHONEUTRIA DEBILIS Pavesi.

♂, 11 mm. *Hab.* Arussi Galla, E. Africa.

♂. Carap. 5-5.5, tib. iv. 4-4.5.

“Occhi della seconda serie recurva equidistanti; mandibole, margine posteriore del solco unguicolare con 4 denti eguali, anteriore con 1 e 2 denti in basso.

“Palpi, tibia, e presso l' apice di un forte processo esterno, più lungo del diametro dell' articolo, a forma di spina di rosa, con la punta subitamente acuminata.

“Mandibole testacee, con due linee nere parallele sulla faccia anteriore, vestite di peli o setole nere.

“Zampe 4. 1. 2. 3 (i. 24 mm., ii. 22, iii. 18, iv. 24.5).”

This extract from Pavesi's description should enable an identification to be made.

I. d. *Descriptions of New Species.**Males.*

- A. Protarsi i. and ii. with a single spine at apex beneath.
- i. Size much larger, 31 mm. Tibiæ and protarsi clothed with thick silky yellow hairs *C. carsoni*, sp. n.
 - ii. Size much smaller, 15-18 mm.
 - a. Base of tarsal joint of palpus produced into a spur.
 - 1. Spur long, curved, falciform, almost as long as the tibia *C. corniger*, sp. n.
 - 2. Spur short, sharp, cuspidate *C. spenceri*, sp. n.
 - b. Base of tarsal joint of palpus simple *C. marshalli*, sp. n.
- B. Protarsi i. and ii. without apical spine beneath *C. hurtoni*, sp. n.

Females.

- A. Protarsi i. and ii. with a single short, stout, apical spine beneath. Mandibles clothed with rufous-grey, yellow, or red hairs at the base in front.
- i. Carapace longer than protarsus iv.
 - a. Mandibles rufous grey at base *C. johnstoni*, sp. n.
 - b. Mandibles red or yellow at base.
 - 1. Mandibles yellow at base *C. vividus* Blk.
 - 2. Mandibles red at base *C. vagus* Blk.
 - ii. Carapace shorter than protarsus iv. Mandibles densely clothed with yellow hairs at base in front *C. velox* Blk.
- B. Protarsi i. and ii. without any apical spine beneath. Mandibles black.
- i. Size larger, 30-33 mm.
 - a. Carapace shorter than patella+tibia iii. and shorter than protarsus iv. Vulva much larger *C. kingsleyi*, sp. n.
 - b. Carapace longer than patella+tibia iii. and equal to protarsus iv. Vulva much smaller. *C. occidentalis*, sp. n.
 - ii. Size smaller, 23 mm. (Carapace longer than protarsus iv.) *C. spenceri*, sp. n.

CTENUS JOHNSTONI, sp. n. (Plate III. fig. 7.)

♀. 37.8. *Hab.* Zomba, Lake Nyassa, E. Africa. Type in coll. Brit. Mus. Nat. Hist. London.

Total length 37.8. Carap. 18×14 . Anter. marg. 8. Prot. i. 13—iv. 16.25.

Colour. Mandibles with basal half clothed with thick rufous-grey pubescence. Abdomen clothed entirely with rufous pubescence, ochre-yellow on legs. There would be nothing, save in the difference in the eye-formula, to distinguish this form from the male from the Cameroons. The colour of the mandibles is identical. There is present in this female the basal inner and outer spine on the anterior tibiæ as well as the single small spine at apex of protarsi i. and ii. beneath.

Vulva. See Plate III. fig. 7.

The eye-formula is similar to that of the male mentioned above, except that the laterals of the second row are higher and the lateral posteriors further from centrals.

Whether this difference is more than sexual, I have not sufficient material on which to base a definite decision, but I should suspect not.

Three females from E. Africa, two being from Lake Nyassa, Zomba, were found in the Museum collection, presented by Sir Harry Johnston.

CTENUS KINGSLEYI, sp. n. (Plate III. fig. 6.)

♀. 30 mm. *Hab.* Cameroons; coll. Kingsley. Type in coll. Brit. Mus. Nat. Hist. London.

♀. Carap. 14.75×11 . Legs 4, 1, 2, 3—i. 60.5—ii. 56—iii. 48—iv. 63. Pat. + tib. i. 21. Pat. + tib. iii. 15.5. Pat. + tib. iv. 19. Prot. i. 13, iv. 17.5.

♀. *Colour.* Carapace mahogany-brown, clothed with short grey pubescence. Mandibles entirely black, clothed with short black hairs, rufous on inner apical margin. Legs clothed with short black and grey hairs and rufous-yellow pubescence. Abdomen unicolorous warm brown, with indistinct dentate dorsal longitudinal pattern, with narrow central dark band beneath bordered with a white line. The face bears a narrow band of rufous pubescence on each side of the ocular area.

Structure. Carapace horizontal, slightly gibbous behind, slightly inclined to base.

Eyes. Second row straight. Line passing through centres of posterior centrals cutting posterior margins of laterals. Diameters of centrals nearly 4 times the transverse diameters of laterals, $\frac{1}{2}$ a diameter apart, $\frac{1}{2}$ a diameter from laterals. Posterior laterals $\frac{1}{3}$ smaller (by diameters) than centrals, $1\frac{1}{4}$ diameters from the latter. Ocular quadrangle broader than long, narrower in front; posteriors $\frac{1}{3}$ larger; anteriors $\frac{2}{3}$ a diameter apart, the same from posteriors. *Clypeus* two full diameters of anterior central eye. *Lower margin* of fang-groove with four stout teeth, upper with three.

Spinulation of legs. Similar to the male of *C. carsoni*, but with

only a single lateral spine on inner basal half of tibia, and no dorsal tibial spines, while the single small apical central inferior protarsal spine is absent.

Vulva. For form of this organ, see Plate III. fig. 6.

The single female specimen from the Cameroons is obviously of a different species, so far as the material at hand enables one to judge, from the male taken by Capt. Burton in the same district. The eye-formula approaches more nearly that of *carsoni*, and though it differs again from this species in this respect one must not speak too confidently of differences which are possibly only sexual. That this form is, however, specifically distinct from *carsoni*, I have not the smallest doubt. The specimen described above was taken by Miss Kingsley.

CTENUS OCCIDENTALIS, sp. n. (Plate III. fig. 8.)

♀. 32 mm. *Hab.* W. Africa. Type in coll. Brit. Mus. Nat. Hist. London.

♀. Total length 33 mm. Carap. 15 × 11. Legs 4, 1, 2, 3—i. 53·5—ii. 50—iii. 42—iv. 57. Pat. + tib. i. 18—iii. 13·5—iv. 17. Prot. i. 12—iv. 15.

♀. *Colour.* Carapace and legs mahogany-brown, clothed with short dull golden-yellow pubescence, no fringing hairs, or very few. Mandibles black throughout. Abdomen clothed with dull golden-yellow pubescence, with double series of 5–6 dorsal dark spots. Sides striped with longitudinal rows of pale spots. Ventral area with two short white stripes at the genital rima, and a long broken white stripe on each side reaching to the spinners. These stripes and spots are much more distinct than in *C. kingsleyi*.

Structure. Carapace horizontal, slightly gibbous behind, abruptly inclined to base.

Eyes. Second row straight by anterior margins. Diameter of centrals 3 times transverse diameter of laterals, $\frac{2}{3}$ a diameter apart, $\frac{1}{3}$ from laterals. Posterior laterals $\frac{1}{6}$ smaller (by diameters) than centrals, $1\frac{1}{4}$ diameters from them. *Ocular quadrangle* broader than long, narrower in front; posteriors $\frac{1}{3}$ larger, anteriors $\frac{2}{3}$ a diameter apart, $\frac{3}{4}$ a diameter from posteriors. *Clypeus* scarcely 2 diameters of anterior central eye. Lower margin of fang-groove with four stout teeth, upper with three.

Spinulation of legs. Similar to that of ♂ *C. carsoni*, but with single lateral spine on inner side of basal half of tib. i., 1—1 on inner basal side of tib. ii. No dorsal tibial spines and no single short apical inferior protarsal spine.

Vulva. See Plate III. fig. 8.

A single female was taken in W. Africa, hab. unknown. It can with *C. kingsleyi* be distinguished from the large species from East Africa by the absence of the protarsal apical spine, by the black mandibles, and of course by the form of the vulva. From *C. kingsleyi* it can be distinguished by its shorter legs, carapace longer than pat. + tib. iii., and the more numerous and distinct pale spots and lines beneath the abdomen; the cusps on each side

of the posterior margin of the vulva are in this species slender and subaculeate, in *C. kingsleyi* they are stout and broadly pointed.

CTENUS SPENCERI, sp. n. (Plate III. figs. 9, 10.)

♂. 18 mm. *Hab.* King William's Town, S. Africa. Type in coll. Brit. Mus.

Total length 15 mm. Carap. 8×6 . Legs: i. 31—ii. 28—iii. 24—iv. 33.

Carapace and legs pale mahogany-brown, clothed with grey pubescence. The former has a more conspicuous central grey band and a broad marginal band, its inner margin being serrate or scalloped. Abdomen with a dark shoulder-spot on each side anteriorly, followed to the spinners by a double series of four small pale spots, the first pair with a black ground. Ventral surface pale rufous-brown, centre dusky with a series of four broken silvery lines, sometimes 6, and a pair of epigynal silvery spots.

Tibia of palpus with a long narrow blunt spur, its apex furnished with a short blunt cusp. Tarsus with a short sharp basal spur, its apex directed upward and slightly outward. Anterior central eyes much smaller and nearer together than the posterior centrals.

♀. Total length 23 mm. Carap. 9.5×7 . Legs: i. 31—ii. 29—iii. 26—iv. 34. Pat. + tib. i. 10.5 —iii. 8—iv. 10.5 . Prot. i. 6.5 —iii. 5.25 —iv. 9.

♀. *Colour.* Carapace dark brown, inclined to mahogany, with central narrow band of dull ochre pubescence, attenuate between eyes, dilate behind, again attenuate from central stria to base, and a broader marginal band of the same colour. Legs clothed with fine close ochre-yellow pubescence; femora with spots of white at base of spines above. Abdomen clothed with yellow-grey pubescence, with central series of indistinct Λ -shaped pale blotches, each branch having a dark spot at its apex.

Ventral area inclined to black, with oblique lateral rows of white spots, two short bars at genital rima, two broken lines between these and the spinners in the centre, and on each side a longer, more distinct broken line reaching to the spinners. Mandibles unicolorous black, clothed with grey hairs.

♀. *Structure.* Carapace horizontal, convex, scarcely gibbous behind, abruptly inclined to base. Eyes. Second row straight, line passing through centre of centrals touches posterior margin of laterals. Centrals four times greater (by diameters) than laterals; $\frac{1}{2}$ a diameter apart, $\frac{1}{6}$ from laterals. Posterior laterals $\frac{1}{6}$ less than centrals, 1 diameter from centrals, $\frac{2}{3}$ from lateral anteriors. Ocular quadrangle much (almost twice) broader than long, much narrower in front, width of anterior row less than half the width of posterior row; diameter of anteriors $\frac{1}{3}$ that of posteriors; the latter $\frac{1}{2}$ a diameter apart, the same from posteriors. Clypeus equal to one diameter of the anteriors. Spinulation of legs similar to that of *C. occidentalis*, except that tibia ii. has one,

not *two* spines on the inner side of the basal half. Inferior margin of fang-groove with four teeth, superior with three.

Vulva very simple, convex. See Plate III. fig. 9.

An adult male and four adult females were taken by Mr. H. A. Spencer at King William's Town, South Africa. Another female was taken by the same collector at East London, South Africa, while a single male was received from the collection of the Rev. O. Pickard Cambridge, taken at Natal, South Africa. In general characters this species inclines to resemble *C. kingsleyi* and *C. occidentalis*, but can easily be distinguished from these by the much greater difference in size between the central posterior and central anterior eyes, and also by the greater narrowness of the clypeus.

CTENUS CARSONI, sp. n. (Plate III. figs. 4 *a*, *b*, 5 *a-c*.)

♂. 31 mm. *Hab.* Mombasa, Victoria Nyanza, and Lake Tanganyika, coll. Carson, &c. Type in coll. Brit. Mus. Nat. Hist. London.

Total length 31 mm. Carap. 15 × 12. Anterior margin 5. Legs: i. 70, ii. 60, iii. 50, iv. 66. Tib. + pat. i. 2—3—5. Tib. + pat. iii. 14·5. Tib. + pat. iv. 19·5. Prot.: i. 17; iii. 12; iv. 18. Stern. 7 × 5·5.

Colour. Carapace mahogany red-brown, clothed with fine silky ochre-yellow pubescence. *Legs* the same as carapace, clothed with very fine silky, close, ochre-yellow pubescence and longer fringing ochre-yellow hairs, scarcely equal to the width of the segments. *Abdomen* dull ochre-brown, clothed with short silky ochre-yellow hairs, unicolorous. *Sternum* dark mahogany-brown. *Mandibles* clothed on basal half with ochre-yellow hairs, apical half less densely.

♂. *Structure.* Carapace longer than broad, narrowed abruptly at point in a line crossing just behind posterior lateral eyes; horizontal above, slightly gibbous behind, obliquely inclined to base. *Eyes* closely grouped, second row straight by anterior margins; centrals four times transverse diameter of laterals, less than $\frac{1}{4}$ a diameter apart, $\frac{1}{4}$ a diameter from laterals; posterior laterals $\frac{1}{6}$ smaller than centrals, $\frac{2}{3}$ a diameter from them. Ocular quadrangle much broader than long; anteriors much smaller, diameter a little over $\frac{1}{2}$ of that of posteriors, $\frac{2}{3}$ a diameter apart, $\frac{1}{2}$ a diameter from centrals. *Clypeus* equal to $1\frac{3}{4}$ diameters of anterior centrals. *Lower margin* of fang-groove with four stout short teeth, upper with three. *Labium* one half of maxillæ, scarcely longer than broad; maxillæ attenuate at base, dilate towards apex, outer side emarginate, rounded on outer apical margin, obliquely truncate on inner apical side.

Legs 1, 4, 2, 3. Femora spinous above. Patella of all four pairs with one short spine on each side. Tib. i. and ii. with 2—2—2—2 spines beneath, No. 4 pair slightly lateral, No. 5 apical, 1—1 (or only one) lateral spines. 1—1—1 dorsal spines. Protarsi i. and ii. with 2—2—2 spines beneath, No. 3 apical, and a single short central apical spine beneath. Protarsi and tarsi i. and ii. entirely

clothed beneath with thick scopulæ. Tib. iii. and iv. with 1—1—1 dorsal spines, besides lateral and inferior spines. Protarsi iii. and iv. spinose, inferior apical spines two. Claw-tuft present. Tarsal claws two.

Palpus. Tibia three times longer than broad, with short external apical black spur, having on each side at base a short distinct cusp. Tarsus piriform. Organs occupying whole breadth of tarsus, consisting of a broad flat chitinous disc, surrounded by a stout broad circumferential marginal piece, terminating at apex in an abruptly curved point, directed backward; and a central lobe, short, curved at base, dilate at apex, simple.

A fine male of this large silky-haired *Ctenus* was taken at Mombasa. Another male was taken by the late Emin Pasha on the southern shores of the Victoria Nyanza, while a third of the same sex was taken at Kavala Island on Lake Tanganyika by Mr. Carson. Two adult males were also obtained.

CTENUS BURTONI, sp. n. (Plate III. figs. 3 a-f.)

♂. 27 mm. *Hab.* Cameroons, W. Africa, coll. Burton. Type in coll. Brit. Mus. Nat. Hist. London.

Total length 27 mm. Carap. 12×9.5 . Legs 1, 4, 2, 3. Pat. + tib. i. 22.5. Pat. + tib. iii. 15. Pat. + tib. iv. 18. Prot. i. 17—iii. 13-25, iv. 19.5.

Structure and colour similar to those of *C. johnstoni*, except that the pubescence is rufous-yellow rather than ochre-yellow; while the basal half of the mandibles is clothed with rufous pubescence, strongly contrasting with the black apical half. *Abdomen* with narrow black central band, broad at genital rima, attenuate behind. *Eyes.* Second row straight, line passing through centres of posterior centrals falling just within posterior margin of laterals; centrals $\frac{2}{3}$ a diameter apart, $\frac{1}{3}$ a diameter from laterals, and twice the size, by transverse diameters; posterior laterals slightly smaller than centrals, over one diameter from them, situate on a black tubercle. Ocular quadrangle scarcely broader than long. Anterior side slightly shorter; central anteriors slightly smaller, $\frac{1}{3}$ a diameter apart, $\frac{1}{3}$ a diameter from posterior centrals. Clypeus one-half wider than diameter of anterior central eye.

Palpus two and a half times longer than broad, broader towards apex; external apical spur short, stout, abruptly curved, bifid at apex. Tarsus elongate-piriform, having at base on upper outer side a short, very stout, curved, sharp, conical spur, its point directed forward and outward. Organs occupying whole width of tarsus, having two stout central lobes, their apices curved towards each other, the outer being stouter, its point lying behind that of the inner, which is longer and more slender.

This western form, though obviously congeneric with the males from the Victoria Nyanza district, differs distinctly in the position of the eyes, and in the presence of a black band beneath the abdomen.

The tibial palpal spur and the organs are of course different

also. A single male was taken in the Cameroons by Capt. Burton. I cannot regard this as the male of the form taken by Miss Kingsley from the same district, since the ocular quadrangle offers differences which I believe will prove to be specific.

CTENUS MARSHALLI, sp. n. (Plate IV. figs. 12, 13.)

♂. 15 mm. *Hab.* Umfuli River, Mashonaland; coll. Marshall. Type in coll. Brit. Mus. Nat. Hist. London.

Total length 15 mm. Carap. 7×5.5 . Legs: i. 40—ii. 34.5—iii. 30—iv. 42. Pat. + tib. i. 13.5—iii. 9.5—iv. 12.5. Prot. i. 10—iv. 13.

Colour. Carapace brown, with very narrow yellow central band, or a pair of closely adjacent central lines of yellow pubescence, throwing off a short distinct branch on each side at central stria. Margins broadly clothed with pale pubescence, but not so close as in central lines. Legs testaceous yellow, clothed with fine hairs and yellow silky pubescence above. Mandibles black with grey hairs. Scopulæ dark brown. *Abdomen* shrivelled, but apparently no dark ventral area.

♂. *Structure* similar to that of *C. carsoni*, including the short apical protarsal inferior spine. Eyes as in *C. carsoni*.

Palpus. Tibia three times as long as broad. External apical apophysis black, broad, dilate at apex; inner angle prolonged and curved inward, outer angle rounded, irregular, with a short sharp spur at the base beneath. Organs very large, occupying whole tarsal width and three-quarters the length. Central lobe narrow, elongate, curved, rather excavate on inner side. A large stout apophysis runs halfway round the inner margin, excavate on inner side, trumpet-shaped at apex, with a black spine beneath; immediately in front of the trumpet-mouth lies a white, delicate, membranous, curved, fungiform process.

A single adult male was taken by Mr. G. A. Marshall on the Umfuli River, South Africa. It is very closely allied to *Phoneutria melanoastra* Bösb., but it is quite distinct.

CTENUS CORNIGER, sp. n. (Plate III. fig. 11.)

♂. 18 mm. Type in coll. O. P. C. *Hab.* Natal, S. Africa.

Total length 18. Carap. 10×7 . Legs i. 33—ii. 20—iii. 27—33.5. Pat. + tib. i. 12—iii. 8—iv. 10

♂. Carapace and legs deep mahogany-brown, clothed with silvery-white and yellow-red hairs. *Abdomen* clothed with rufous pubescence; with a pale patch at base above, followed to spinners by a double series of pale spots of pubescence. Ventral area pale rufous.

Tibial joint of palpus with a short broad process, emarginate or almost bifid at apex. Spur at base of tarsus long, curved, falciform, almost as long as the tibia; its apex sharp, abruptly curved outwards, directed across the apex of the tibial joint.

Anterior central eyes much smaller and nearer together than the posterior centrals.

A single adult male of this fine spider was kindly submitted to me for description by the Rev. O. Pickard Cambridge, who received it from Natal.

II. THREE-CLAWED CTENIFORM SPIDERS.

II. a. *Introduction.*

These spiders, including *Cupiennius*, Simon, *Lycotenus*, F. Cb., *Thalassius*, Simon, and *Dolopæus*, Thorell, will doubtless fall under the family *Pisauridæ*. The first two genera must, I think, be separated from the others under a different subfamily, for which I suggest the name *Lycoteniinæ*, while the other two will form a group under the subfamily *Dolomedinæ*. Of the habits of *Cupiennius* I cannot speak with certainty, though I should fancy that the spiders are probably more or less usually found in marshy, swampy places. Like other *Pisauridæ* they carry the egg-cocoon under the sternum. *Lycotenus* is essentially lacustrine in its habit, though, like *Dolomedes*, often found wandering long distances from its headquarters.

The habits of the two other genera *Dolopæus* and *Thalassius* are also similar, the spiders themselves very much resembling an elongate *Dolomedes*. The marking of the European *Dolomedes fimbriatus* with elongate bands of dull yellow having much the same disposition as those present in these two genera may be accounted for, possibly, by the fact that this arrangement of colour renders them exceedingly difficult to observe when crouched lengthwise along the stem or blade of the fading, yellow-tinted sedge-grass.

Mr. Cumming has contributed a valuable note on the habit of *Thalassius*, taken on the Persian Gulf (see p. 31).

The genera may be distinguished as follows:—

Genera.

- | | |
|--|----------------------------|
| <p>A. Central anterior eyes distinctly larger than central posteriors. Clypeus about equal to length of ocular quadrangle. Tibiæ of first pair of legs much longer (by half) than carapace. Lateral pale bands on carapace very broad, extending to the margin</p> | <p>DOLOPÆUS, Thor.</p> |
| <p>B. Central anterior eyes not larger than central posteriors. Clypeus, in height, equal to the length of ocular quadrangle. Tibiæ of first pair of legs as long or slightly shorter than carapace. Lateral pale bands on carapace narrow and remote from the margin ; sometimes absent</p> | <p>THALASSIUS, E. Sim.</p> |

Genus DOLOPÆUS, Thor.

(*Dolomedes*, Doleschall.)

Generic Diagnosis. The same as *Thalassius* except as indicated in the differential table.

Type *D. cinctus* Thor., ♀ ad. K. Svenska Vet.-Akad. Handl. xxiv. no. 2, p. 60. (Plate IV. figs. 6, 7.)

I have not seen the type nor examples of the species, but I have before me immature specimens identified by Thorell as *D. albocinctus* Dol. (sub *Thalassius*), which present all the characters by which *Dolopæus* may be separated from *Thalassius*; while Thorell's description of the eyes of *D. cinctus* also indicates the same difference. Thorell considered his *Dolopæus* to be identical with *Thalassius*, and on pp. 350 and 351 of my paper on Eastern Cteniform Spiders, Ann. Mag. Nat. Hist. ser. 6, xx. 1897, I came to the same conclusion. An examination of fresh material has, however, led me to believe that the original differentiation will hold good, and I am very glad to be able to recharacterize and restore Dr. Thorell's genus.

Females.

- | | |
|--|--|
| i. Legs short and not fringed on the last two segments with feathery hairs | <i>D. doleschallii</i> , sp. n. |
| ii. Legs long and fringed on the last two segments with feathery hairs | <i>D. simoni</i> , sp. n. |
| I am unable to satisfy myself as to the identity of these two species | { <i>D. albocinctus</i> (Dol.).
<i>D. cinctus</i> Thor. |

Genus THALASSIUS, Simon.

Titurius, Sim. Nom. præocc.

Generic Diagnosis. Tarsal claws 3. Anterior row of eyes recurved; laterals halfway between anterior and posterior centrals. Teeth on lower margin of fang-groove 3. Tarsi of fourth pair of legs not furnished with spines beneath. Tibiæ i. and ii. with a double row of 4—4 spines beneath. Eyes all subequal. Clypeus as high as length of ocular area. Tibia of first pair of legs scarcely longer—often shorter—than carapace. Lateral pale bands on carapace sometimes absent, nor when present remote from margin.

II. b. List of Species already described, with Notes on their Identities.

1884. *Titurius fimbriatus* (Walck.).—Simon, Ann. Mus. Genov. xx. p. 328, ♀. Cape of Good Hope.
 1884. *Titurius pallidus* (L. Koch).—Simon, Ann. Mus. Genov. xx. p. 328. Egypt and Abyssinia.
 1884. *Titurius spinosissimus* (Karsch).—Simon, Ann. Mus. Genov. xx. p. 328. River Congo.
 1897. *Thalassius unicolor* E. Simon in Donaldson Smith's 'Through Unknown African Countries,' p. 389.

Simon in this work selects as the type of *Titurius*, *Ctenus fimbriatus* Walck. Ins. Apt. i. p. 364, and includes *C. pallidus* L. K. and *C. spinosissimus* Karsch as congeneric with it.

In Rev. Suisse Zool. Genève, 1893, p. 327, Simon says of *Thalassius*:—"Ce genre renferme actuellement dix espèces: *fimbriatus* (*Ctenus*) Wlk., du Cap; *marginatus* (*Ctenus*) Wlk., des île

Salomon; *marginellus* Sim., de l'Indo-Chine; *pallidus* (*Ctenus*) L. Koch, d'Égypte; *spathularis* (*Dolomedes*) Van Hasselt, de Sumatra; *spinosissimus* (*Ctenus*) Karsch, du Congo; *syriacus* (*Ctenus*) Camb., de Syrie; ? *torvus* (*Ctenus*) Pavesi, du Scioa; et probablement *cinctus* (*Dolopæus*) Thorell, des îles Nikobars. Il est remplacé dans l'Amérique du sud par le genre *Ancylometes*, Bertkau (type *A. vulpes* Bertk.).”

Since *Thalassius*, Sim., both according to Simon's diagnosis and the type of *T. unicolor* Sim., now before me, possesses 3 teeth only on the lower margin of the fang-groove, I am unable to agree that *Dolomedes spathularis* Van Hasselt belongs to this genus, as Simon states (see above).

That it is one of the Cteniform Lycosidæ appears highly probable from the fact that the fourth pair of legs are the longest, though Van Hasselt makes no mention of the number of tarsal claws, which alone is a sure criterion.¹

Females.

- a. Carapace and abdomen unicolorous, without lateral pale bands. Tibia i. very slightly longer than carapace..... *T. unicolor* E. Sim.
- b. Carapace and abdomen with pale lateral bands. Tibia i. as long as or shorter than carapace.
 - i. Tibia i. as long as carapace.
 - * For form of vulva see Plate IV. *T. jakakari*, sp. n.
 - ** " " " " *T. cummingi*, sp. n.
 - ii. Tibia i. " shorter " than carapace.
 - * For form of vulva see Plate IV. *T. phipsoni*, sp. n.
 - ** " " " " *T. spenceri*, sp. n.

II. c. *Descriptions of New Species.*

THALASSIUS UNICOLOR Sim. (Plate IV. fig. 2.)

♀ ad. 20 mm. *Hab.* Sheik Hussein. Type in coll. Brit. Mus. Nat. Hist. London. Mr. Donaldson Smith's 'Through Unknown African Countries,' p. 389 (1897).

♀. Total length 20 mm. Carap. 9 × 7.5. Legs: i. 40—ii. 40—iii. 38—iv. 44. Pat. + tib. i. 14—iii. 11.75—iv. 14. Prot. i. 8.5—iii. 8—iv. 10.

Colour. Entirely unicolorous yellow-ochreous. Carapace and legs clothed with close, fine, hoary-white pubescence. Abdomen dull ferruginous yellow, unicolorous.

Structure. See generic diagnosis, p. 28. Vulva, Plate IV. fig. 2.

This form can be recognized by the absence of white bands on the carapace and abdomen.

THALASSIUS SPENCERI, sp. n. (Plate IV. figs. 1 a, b, & 8.)

♀. 17 mm. *Hab.* East London, S. Africa; coll. E. Baldwin Spencer. Type in Brit. Mus. Nat. Hist.

¹ Since writing the above a specimen obviously identical with Van Hasselt's *D. spathularis* has come before me from Deli, Sumatra. It is a true *Dolomedes* and not a *Thalassius* or *Dolopæus*, having four teeth on the fang-groove and three tarsal claws.

Total length 17 mm. Carap. 7×6 . Legs: i. 30—ii. 30—iii. 27—iv. 32·5. Pat. + tib. i. 10—iii. 8·5—iv. 10·5. Prot. i. 6·5—iii. 6—iv. 7·5.

Colour. Carapace, legs, and abdomen rich olive-brown. Carapace with broad white band on each side submarginal, as far from margin as width of band, not extending to the margin. Abdomen with band of silvery-white on each side extending from the anterior shoulders to the spinners. Ventral area pale yellow.

Structure. Similar to that of *T. unicolor*.

It is possible that this species is *Thalassius fimbriatus* (Walck.) Sim., but I can find no description which one can consider sufficient for identification. The species of this genus apparently are very closely allied, and in the form of the vulva are so much alike that identification becomes a difficult matter.

Vulva. See Plate IV. fig. 1 *b*. A single female was taken by Mr. H. A. Spencer at E. London, South Africa, and is now in the British Museum. Also another female from Sierra Leone. I can detect no difference between the two specimens.

THALASSIUS JAYAKARI, sp. n. (Plate IV. figs. 4, 9–11, & 14.)

♀ ad. 27 mm. *Hab.* Muscat, Arabia. Type in coll. Brit. Mus. Total length 27 mm. Carap. $10\cdot5 \times 8\cdot5$. Legs wanting in some joints. Approximately the same as in *T. phipsoni*. Tibia i. 10·5.

Colour. Carapace, legs, and abdomen the same as in *T. phipsoni*.

Structure. Tibia i. as long as carapace. Vulva, see Plate IV. fig. 4.

An adult female was taken by Mr. A. G. Jayakar at Muscat on the Gulf of Oman, Arabia. Another adult female, much rubbed, so that the white scales of the lateral bands have been obliterated, was taken at Muscat by the same gentleman.

THALASSIUS CUMMINGI, sp. n. (Plate IV. fig. 3.)

♀ ad. 20 mm. *Hab.* Fao, Persian Gulf. Type in coll. Brit. Mus.

Total length 20 mm. Carap. 8×7 . Legs: i. 35—ii. 35—iii. 34—iv. 40. Tibia i. 8.

Colour. Carapace and legs red-brown, clothed with fine grey pubescence, the former with two lateral bands of white scales, not extending laterally to the margin. The base of each of the spines on the legs is set in a dark brown spot. Abdomen delicate olive-ochreous, clothed with fine grey pubescence, having a narrow band of white scales on each side; these bands, both on the carapace and the abdomen, are margined with a rich brown line. Protarsi fringed with fine hair.

Structure. Tibia i. as long as carapace. Vulva, see Plate IV. fig. 3.

An adult female of this beautiful species was taken by Mr. W. G. Cumming in the Persian Gulf. This gentleman has been good enough to contribute valuable data on the habits of this spider, thus giving us a knowledge of the habits of the genus, which

have not before been placed on record, so far as I am aware. Mr. Cumming relates that the spider was seated on the outside of the jolly-boat, above the water. When he tried to catch it, it took to the water and made for a plant near the boat; and on again attempting to capture it, it beat a retreat again to the boat, where it was eventually secured. This reminds me exactly of the habits of other *Lycotenuinæ* which I met with on the Amazons, as well as of the true dolomedine forms such as *Triclaria*.

THALASSIUS PHIPSONI, sp. n. (Plate IV. fig. 5.)

♀ ad. 27 mm. *Hab.* Makim, Dorun, India. Type in coll. Brit. Mus.

Total length 27 mm. Carap. 10.5×8.75 . Legs: i. 41—ii. 41—iii. 40—iv. 47. Tibia i. 9.5.

Colour. Carapace and legs ferruginous-grey, the former having two rich bands of white scales extending, longitudinally, from the anterior angles of the clypeus to a point halfway down the posterior declivity, laterally not extending to the margin. *Abdomen* entirely delicate ochreous-grey with olive tint, having a broad lateral band of rich white scales on each side.

Structure. Tibia i. shorter than carapace. Vulva, see Plate IV. fig. 5.

This fine species is very similar in general appearance to *T. jayakari*, but the difference of locality, and the difference in the vulva and in the relative length of the tibia of the first pair of legs compared with the carapace, prove that it is certainly a distinct species. An adult female was taken by Mr. H. M. Phipson at Makim and a young female at Dorun, in British India.

NILUS, Cambr., 1876.

NILUS CURTUS Cbr.

♀ juv. 5 mm. Spid. Egypt, p. 596, pl. lx. fig. 13, Alexandria.

“Eyes in two not very widely separated and almost equally curved transverse rows; the convexity of the curves directed forward, but the front row is the shortest. Each tarsus ends with three curved claws.”

From the figures on pl. lx. (*l. c.*) one would conclude the species to belong to some genus closely allied to *Dolomedes*.

Having carefully examined the type, I find it to be a three-clawed form with 2—2—2 long subtibial spines, with an eye-formula closely resembling *Thalassius*, and with three teeth on inferior margin of fang-groove. Whether it is identical with *Thalassius* or not one would not like to speak too positively from such very immature specimens, but judging from the number of spines beneath tibiæ i. and ii. one would say most probably not. Adult forms from the neighbourhood of Alexandria will probably settle the point.

EXPLANATION OF THE PLATES.

PLATE III.

- Fig. 1. *Ctenus velox*, p. 15, ♀. Abdomen, ventral area.
 2. *Ctenus velox*, ♀. Vulva.
 3. *Ctenus burtoni*, p. 25, ♂. *a.* Tibial spur of palpus. *b.* Do., lateral view. *c.* Tarsus of palpus, showing basal cusp. *d.* Tarsus and palpal organs. *e.* Palpal organs enlarged. *f.* Eyes from in front.
 4. *Ctenus carsoni*, p. 24, ♂. *a.* Eyes from in front. *b.* Tarsus of palpus from beneath.
 5. *Ctenus carsoni*. Spur of left tibia of palpus. *a.* From outside. *b.* Spur enlarged. *c.* From beneath.
 6. *Ctenus kingsleyi*, p. 21, ♀. Vulva.
 7. *Ctenus johnstoni*, p. 21, ♀. Vulva.
 8. *Ctenus occidentalis*, p. 22, ♀. Vulva.
 9. *Ctenus spenceri*, p. 23, ♀. Vulva.
 10. *Ctenus spenceri*, ♂. Tibia of palpus and base of tarsus, showing short spur.
 11. *Ctenus corniger*, p. 26, ♂. Tibia of palpus and base of tarsus, showing short spur.

PLATE IV.

- Fig. 1. *Thalassius spenceri*, p. 29, ♀. *a.* Eyes from in front. *b.* Vulva.
 2. *Thalassius unicolor*, p. 29, ♀. Vulva.
 3. *Thalassius cummingi*, p. 30, ♀. Vulva.
 4. *Thalassius jayakari*, p. 50, ♀. Vulva.
 5. *Thalassius phipsoni*, p. 31, ♀. Vulva.
 6. *Dolopæus cinctus*, p. 28, ♀. Eyes from in front.
 7. *Dolopæus cinctus*, ♀. Eyes from the side.
 8. *Thalassius spenceri*, p. 29. Eyes from the side.
 9. *Thalassius jayakari*, p. 30. Fang-groove.
 10. *Thalassius jayakari*. Tarsal claws.
 11. *Thalassius jayakari*. Protarsus and tarsus.
 12. *Ctenus marshalli*, p. 26, ♂. Palpal organs.
 13. *Ctenus marshalli*, ♂. Tibia of palpus, from above.
 14. *Thalassius jayakari*, p. 30, ♀. Spider, enlarged nearly one third.

3. On some Crustaceans from the South Pacific.—Part I.
Stomatopoda. By LANCELOT ALEXANDER BORRADAILE,
 M.A., Lecturer in Natural Sciences at Selwyn College,
 Cambridge¹.

[Received November 30, 1897.]

(Plates V. & VI.)

The collections of Crustaceans treated of in this paper are those of Mr. J. S. Gardiner, of Gonville and Caius College, Cambridge, from the islands of Funafuti (Ellice group) and Rotuma, and of Dr. A. Willey, from New Britain, the Loyalty Islands, and other South Pacific localities. Both of them were made in connection with the "Balfour Memorial Fund," Dr. Willey holding the Balfour Studentship and Mr. Gardiner being also aided by a grant from the fund.

¹ Communicated by Prof. ALFRED NEWTON, F.R.S., F.Z.S.

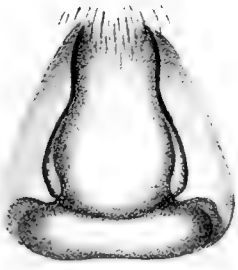

7.



2.

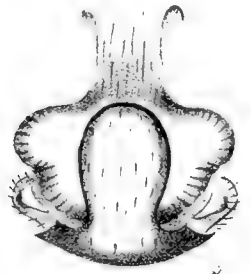

8.

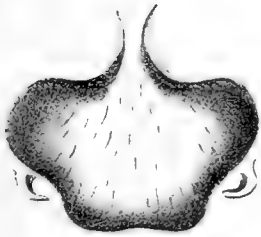

9.

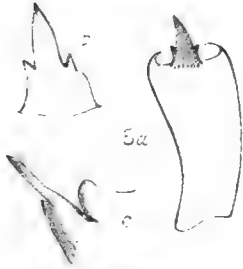

3a.

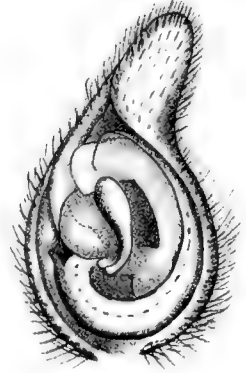

4b.



3f.

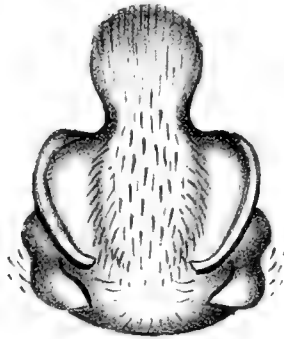

6.



4a.



3e.



3d.



3c.

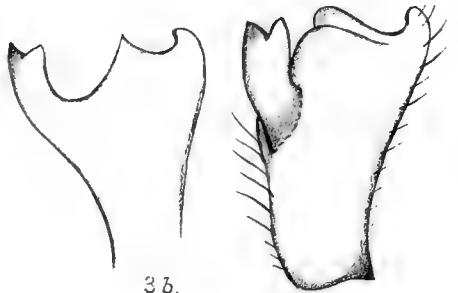

3b.

3a.

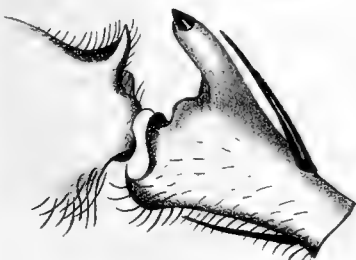

10.



1.

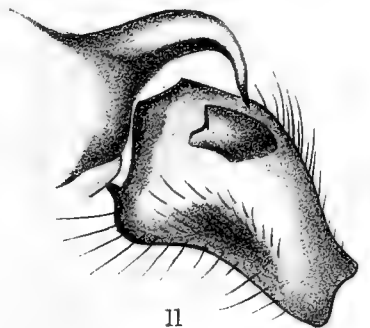

11.



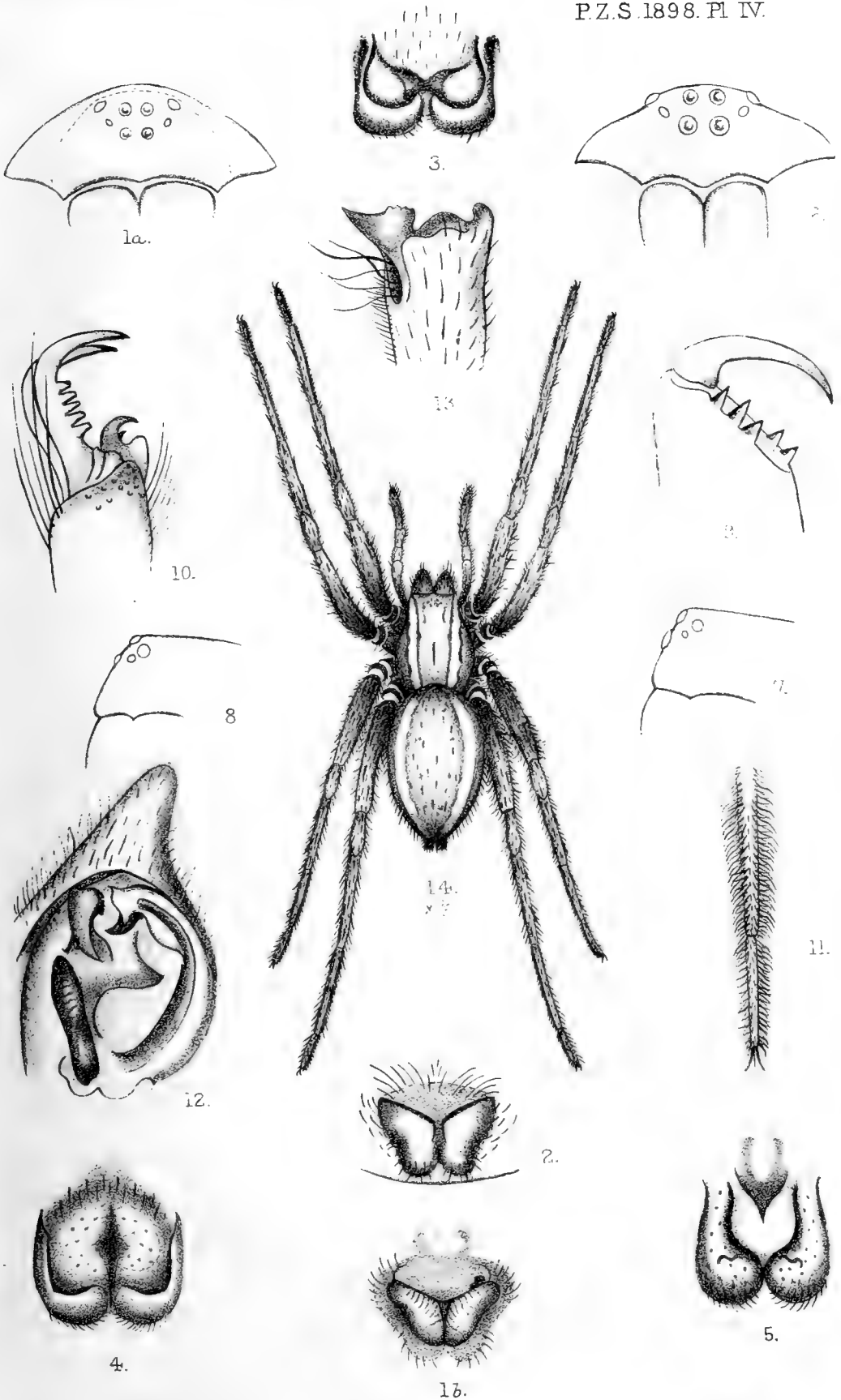

F.O.Pickard-Cambridge, del. et lith.

West, Newman imp.

African Cteniform Spiders.

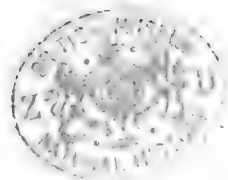

In the following lists three of the species will be seen to be new.

Mr. Gardiner's collection contained examples of:—

Protosquilla cerebralis Brooks. 1 ♂ from Rotuma.

Gonodactylus chiragra (Fabr.). 8 ♂ and 8 ♀ from Rotuma ;
1 ♂ and 5 ♀ from Funafuti.

Gonodactylus chiragra (Fabr.), var. *smithii* Pocock. 1 ♂ and
2 ♀ from Rotuma.

Gonodactylus glabrous Brooks. 1 ♀ from Rotuma.

Gonodactylus espinosus, sp. n. 1 ♂ from Rotuma.

Odontodactylus scyllarus (Linn.). 2 ♂ and 2 ♀ from Rotuma.

Pseudosquilla ciliata (Fabr.). 1 ♀ from Funafuti.

Pseudosquilla oxyrhyncha, sp. n. 1 ♂ from Rotuma.

Lysiosquilla maculata (Fabr.). 1 ♂ and 1 ♀ from Rotuma.

Dr. Willey's collection comprised specimens of:—

Protosquilla cerebralis Brooks. 2 ♀ from Sandal Bay, Lifu,
Loyalty Islands ; 1 ♂ from Pigeon Island, New Britain.

Protosquilla trispinosa (Dana). 1 ♀ from Lifu, Loyalty
Islands.

Gonodactylus chiragra (Fabr.). 2 ♂ and 5 ♀ from Lifu,
Loyalty Islands ; 1 ♂ and 1 ♀ from the Isle of Pines ;
1 ♂ and 1 ♀ from Talili Bay ; 1 ♀ from Ralu ; 1 ♂,
locality not stated.

Gonodactylus chiragra (Fabr.), var. *smithii* Pocock. 1 ♂ and
2 ♀ from Lifu, Loyalty Islands.

Odontodactylus scyllarus (Linn.). 1 ♀ from New Britain.

Squilla multituberculata, sp. n. 1 ♂ and 2 ♀ from Sandal Bay,
Lifu, Loyalty Islands.

Pseudosquilla ciliata (Fabr.). 1 ♀ from Uvea, Loyalty Islands ;
1 ♂ from Blanche Bay, Loyalty Islands.

I now proceed to general remarks on the above-mentioned species.

1. PROTOSQUILLA CEREBRALIS Brooks. (Plate V. fig. 6 a.)

Protosquilla cerebralis, Brooks, 'Challenger' Stomatopoda, p. 72,
pl. xiv. figs. 2 and 3, pl. xvi. figs. 2 and 3 (1886).

Brooks's examples of this species were all females. Fortunately, however, Mr. Gardiner's and Dr. Willey's collections each contain a male specimen, so that I have been able to have a figure made of the peculiar structure on the endopodite of the 1st abdominal appendage in this sex (fig. 6 a, Plate V.). The importance, from a systematic point of view, of a record of the form of this organ in each species has been pointed out by Brooks (*loc. cit.* p. 13).

1 ♂ from Rotuma ; 2 ♀ from Sandal Bay, Lifu, Loyalty Islands ;
1 ♂ from Pigeon Island, New Britain.

2. *PROTOSQUILLA TRISPINOSA* (Dana). (Plate V. figs. 1, 1 a.)

Gonodactylus trispinosus, Dana, Zool. U.S. Expl. Exped., Crust. i. p. 623 (1852); Miers, Ann. Mag. Nat. Hist. 5, v. p. 121, pl. iii. fig. 10 (1880).

Protosquilla trispinosa, Brooks, 'Challenger' Stomatopoda, p. 71 (1886).

The naming of this species is generally credited to White (List Crust. Brit. Mus. p. 75, 1847), but, as White published merely the name and a reference to a plate (in the "Zoology of the Voyage of the 'Erebus' and 'Terror'") which never appeared, the true author is Dana, who was the first to describe it.

No complete figure of *P. trispinosa* has ever been published, and as the representation of the telson given by Miers does not accurately depict either White's original specimen in the British Museum or that in Dr. Willey's collection, which themselves agree closely, I have determined to append a figure to the present note.

All descriptions of this species hitherto published have overlooked the fact that the three tubercles of the telson are not smooth, but covered with minute spinules. An amended definition of the species will run as follows:—

"A *Protosquilla* with the two antero-lateral spines of the rostrum nearly as long as the median; carapace with corners nearly rectangular, anterior more acute than posterior; fifth abdominal segment longitudinally corrugated; sixth abdominal segment clearly marked off from the telson, and bearing six smooth tubercles; telson bearing a median and two lateral large tubercles covered with minute spinules, the median anterior to the two laterals; posterior border of telson divided by deep narrow fissures into six lobes; submedian, intermediate, and lateral spines of the telson small and placed in notches; several submedian spinules." Length about 40 mm. 1 ♀ specimen from Lifu, Loyalty Islands.

3. *GONODACTYLUS CHIRAGRA* (Fabr.). (Plates V. fig. 4, & VI. fig. 8.)

Squilla chiragra, Fabricius, Ent. Syst. t. iii. pt. i. p. 513 (1793).

Gonodactylus chiragra, Latreille, Encycl. Méth. x. p. 473 (1825); Dana, Zool. U.S. Expl. Exped., Crust. i. p. 623, pl. xli. figs. 5 a, b (1852); Miers, Ann. Mag. Nat. Hist. 5, v. p. 118 (1880); Brooks, 'Challenger' Stomatopoda, p. 56, pl. xv. fig. 4 (1886).

Gonodactylus smithii, Pocock, Ann. Mag. Nat. Hist. 6, xi. p. 475, pl. xx. B. fig. 1 (1893).

Pocock has described, under the name of *Gonodactylus smithii* (Plate V. figs. 2, 2 a, b), a form differing from the type as follows:—

- (i.) The crests upon the sixth abdominal segment and telson are much more compressed and carinate than in *chiragra*.
- (ii.) The crests upon the sixth abdominal segment are produced, without constriction, into long spines.

- (iii.) The upper edge of the median crest of the telson is almost straight, and is produced posteriorly into a spine.
 (iv.) The animal is more robust.

The specimens described by Pocock were taken in the same locality (Arafura Sea) with examples of typical *G. chiragra*, and this is the case also with Mr. Gardiner's and Dr. Willey's specimens. Since they are connected by a series of intermediates with the type, they must be regarded as a variety only. There is, however, one character—not mentioned by Pocock, but present, as I have seen, in his type specimen—that comes near to being diagnostic of this form. This character is the presence, on each side of each of the first five abdominal tergites, of a small, sharply-defined, dark spot. Only one of the specimens is without these spots, and, as this is very small and has the appearance of having been considerably bleached by the alcohol, it is possible that it does not really form an exception. On the other hand, I have only met them on one *G. chiragra* not agreeing with Pocock's description of *G. smithii*.

All the examples of *G. smithii* are small (10–45 mm. long), as were those of Pocock, but certain specimens somewhat approaching them are considerably larger. There are several undoubted examples of *G. chiragra* of about the same size as *G. smithii*.

Two examples of *G. chiragra* from the Bahamas now in the Cambridge University Museum of Zoology differ from the type as found in the Pacific only in the presence of a minute ridge on the median side of the carinæ of the intermediate spines of the telson. Several specimens in the British Museum, from various West Indian and South American localities, present this feature and have been labelled *Gonodactylus oerstedii* (Plate V. fig. 3) by Dr. H. J. Hansen, who has since instituted the species by a brief description in a footnote to p. 65 of the 'Isopoden, Cumaceen u. Stomatopoden der Plankton-Expedition.' I am permitted by the courtesy of Dr. S. F. Harmer to figure the telson of one of the Cambridge specimens of this form.

The present collections include :—

8 ♂ and 8 ♀ from Rotuma; 1 ♂ and 5 ♀ from Funafuti; 2 ♂ and 5 ♀ from Lifu, Loyalty Islands; 1 ♂ and 1 ♀ from the Isle of Pines; 1 ♂ and 1 ♀ from Talili Bay; 1 ♀ from Ralu; 1 ♂, locality not stated.

There are besides the following specimens of var. *smithii* :—

1 ♂ and 2 ♀ from Rotuma; 1 ♂ and 2 ♀ from Lifu, Loyalty Islands.

4. GONODACTYLUS ESPINOSUS, sp. n. (Plate V. figs. 5, 5 a, b.)

Definition.—“A *Gonodactylus* with cylindrical eyes; blunt, rounded antero-lateral angles of the rostrum; elongated carapace with rounded antero-lateral and almost rectangular postero-lateral angles; lateral margins of first exposed thoracic segment not produced, of second produced and square, of third produced and truncate, of fourth produced and subacute; lateral margins of first to fifth abdominal segments with small carinæ, but not produced into a spine; sixth abdominal segment with four rounded dorsal

prominences, and with two lateral carinæ, each produced into a spine; telson with three rounded dorsal longitudinal prominences not bearing spines, and with four narrow elongated carinæ posterior to the rounded prominences; lateral and intermediate marginal spines of the telson obsolete, submedians long and each tipped with a minute movable spinule."

Colour (in alcohol) a uniform dark olive-green.

Length of the single (♂) specimen 18 mm. from tip of rostrum to bottom of groove between submedian spines of telson.

This species closely resembles *G. chiragra*, from which, however, it differs in the absence of the intermediate spines of the telson and in the consequently more elongated shape of that segment.

1 ♂ from Rotuma.

5. GONODACTYLUS GLABROUS Brooks.

Gonodactylus glabrous, Brooks, 'Challenger' Stomatopoda, p. 62, pl. xiv. fig. 5, pl. xv. figs. 7, 9 (1886).

Gonodactylus graphurus, de Man, Arch. f. Naturges., Jahrg. 53, Bd. i. p. 573 (1887).

Gonodactylus glaber, Pocock, Ann. Mag. Nat. Hist. 6, xi, p. 474 (1893).

Pocock regards the name of this species as due to a misspelling in the original description, but, as it appears several times in Brooks's article and is always spelt in the same way, this would seem not to be the case.

1 ♀ from Rotuma.

6. ODONTODACTYLUS SCYLLARUS (Linn.). (Plate V. fig. 6.)

Cancer scyllarus, Linnæus, Syst. Nat. 10th ed. i. p. 633 (1758); 12th ed. p. 1054 (1766).

Squilla scyllarus, Fabricius, Ent. Syst. t. iii. pt. i. p. 512 (1793).

Gonodactylus scyllarus, Latreille, Encycl. Méth. x. p. 472 (1825); Cuvier, R. A. 3rd ed., Crust., Atlas, pl. lv. fig. 2; Miers, Ann. Mag. Nat. Hist. 5, v. p. 115 (1880).

Odontodactylus scyllarus, Bigelow, Proc. U.S. Nat. Mus. xvii. p. 495 (1894).

2 ♂ and 2 ♀ from Rotuma; 1 ♀ from New Britain.

Figure 6, Pl. V., represents the endopodite of the 1st abdominal appendage of the male of this species.

7. PSEUDOSQUILLA CILIATA (Fabr.).

Squilla ciliata, Fabricius, Ent. Syst. t. iii. pt. i. p. 512 (1793).

Squilla stylifera, Lamarck, Hist. An. sans Vert. v. p. 189 (1818).

Pseudosquilla stylifera, Dana, Zool. U.S. Expl. Exped., Crust. i. p. 622, pl. xli. fig. 4 (1852).

Pseudosquilla ciliata, Miers, Ann. Mag. Nat. Hist. 5, v. p. 108 (1880); Brooks, 'Challenger' Stomatopoda, p. 53, pl. xv. fig. 10 (1886).

The specimens agree with Brooks's Pacific examples in the points in which the latter differ from his West Indian ones.

1 ♀ from Funafuti; 1 ♀ from Uvea, Loyalty Islands; 1 ♂ from Blanche Bay, Loyalty Islands.

8. *PSEUDOSQUILLA OXYRHYNCHA*, sp. n. (Plate VI. figs. 9, 9 a-d.)

Definition.—“A *Pseudosquilla* with broad, club-shaped eyes; rostrum transverse with a delicate median spine; dactylus of the raptorial claw with three teeth (including the terminal tooth); manus of the raptorial claw with three movable spines; two large dark spots on the carapace not surrounded by a white ring; lateral process on the first free thoracic segment wanting, on the second and third truncate, on the fourth subacute; basal prolongation of the uropods ending in two spines; telson with median crest and six other carinæ (including those of the lateral margins), the carinæ immediately lateral to the crest being small and serrated.”

Colour. Abdomen olive-green, mottled with paler green; carapace greenish brown, mottled with cream; raptorial claw brown (dactylus purple), mottled with cream.

Length of the single (♂) specimen 88 mm. from tip of rostral spine to bottom of notch between submedian spines of telson.

This species is intermediate between *P. oculata* Brullé and *P. ornata* Miers. It resembles the former in the presence of a small median spine on the rostrum, and the latter in having only six carinæ on the telson. From both it differs in the absence of definite eye-spots on the carapace; these being represented by two irregular dark marks, not surrounded by lighter rings.

1 ♂ specimen from Rotuma.

9. *LYSIOSQUILLA MACULATA* (Fabr.).

Squilla maculata, Fabricius, Ent. Syst. t. iii. pt. i. p. 511 (1793); H. Milne-Edwards, Hist. Nat. Crust. t. ii. p. 518, pl. xxvi. fig. 11 (1837).

Lysiosquilla maculata, Miers, P. Z. S. 1877, p. 138; id. Ann. Mag. Nat. Hist. 5, v. p. 5, pl. i. figs. 1 and 2 (1880); Brooks, ‘Challenger’ Stomatopoda, p. 45, pl. x. figs. 1-7 (1886).

The marked difference observed by Miers (Ann. Mag. *loc. cit.*) and by Brooks in the single females they were able to examine holds good for the present specimens, the spines arming the inner margin being, in the male, long, while in the female they are short, and reduced proximally to mere serrations.

Mr. Gardiner has been kind enough to furnish me with the following note on the habits of this species:—

“*Lysiosquilla maculata* (Fabr.). This species is found in the boat channel at Rotuma. It lives in pairs in tunnels on the sandy bottom. These are sometimes as much as 20 feet long, and usually have two exit holes. Each hole is inhabited by a male and a female, which take up their positions at the two exits, with the dactylus and propodite of the raptorial claw widely extended and

just projecting. Any small fish passing over is seized, and the animal retreats with it into its tunnel."

10. *Squilla multituberculata*, sp. n. (Plate VI. figs. 7, 7 a-c.)

Definition.—"A *Squilla* with elongated flattened eyes; rostrum subrectangular, without carinæ, and with acute antero-lateral angles; dactyle of the raptorial claw with four teeth (including the terminal tooth) on the inner margin, and three short teeth on the outer margin; carapace small, narrowed in front, with rounded angles; lateral processes on the fifth thoracic segment acute, on the sixth to eighth subtruncate; no carinæ on the thoracic or first five abdominal segments; sixth abdominal segment longitudinally corrugated; telson covered with small blunt spines; submedian marginal spines of telson with movable tips; several (four or more) submedian spinules, several (six or more) intermediate spinules."

Colour (in alcohol, specimens seem somewhat bleached) pale yellow or greenish yellow.

Length (only 3 specimens), 12-13 mm.

This species would appear to be allied to *Squilla quadridens* Bigelow [Johns Hopkins Univ. Circ. 106, p. 100 (1893)], and in a less degree to *S. polita* Bigelow [J. Hop. Univ. Circ. 88 (1891)].

1 ♂ and 2 ♀ from Sandal Bay, Lifu, Loyalty Islands.

EXPLANATION OF THE PLATES.

PLATE V.

Fig. 1. *Protosquilla trispinosa*, p. 34, ♀, ×2.

1 a. " " telson, ×4.

2. *Gonodactylus chiragra*, var. *smithii*, p. 34, ♀, ×1½.

2 a. " " " " telson from the side, ×4.

2 b. " " " " telson from above, ×4.

3. *G. oerstedii*, p. 35, ♀, telson from above, ×4.

4. *G. chiragra*, p. 34, telson from the side, ×4.

5. *G. espinosus*, p. 35, ♂, ×2.

5 a. " ♂, telson from above, ×4.

5 b. " ♂, endopodite of 1st abdom. app. considerably magnified,

6. *Odontodactylus scyllarus*, p. 36, ♂, endopodite of 1st abdom. app. magnified.

6 a. *Protosquilla cerebralis*, p. 33, ♂, endopodite of 1st abdom. app. considerably magnified.

PLATE VI.

Fig. 7. *Squilla multituberculata*, p. 38, ♂, ×6.

7 a. " " telson from above, ×12.

7 b. " " telson from below, ×12.

7 c. " " endopodite of 1st abdom. app. considerably magnified.

8. *Gonodactylus chiragra*, p. 34, nat. size.

9. *Pseudosquilla oxyrhyncha*, p. 37, ♂, nat. size.

9 a. " " endopodite of 1st abdom. app. magnified.

9 b. " " 1st maxilliped, ×2½.

9 c. " " 3rd maxilliped, ×2½.

9 d. " " 5th maxilliped, ×2½.

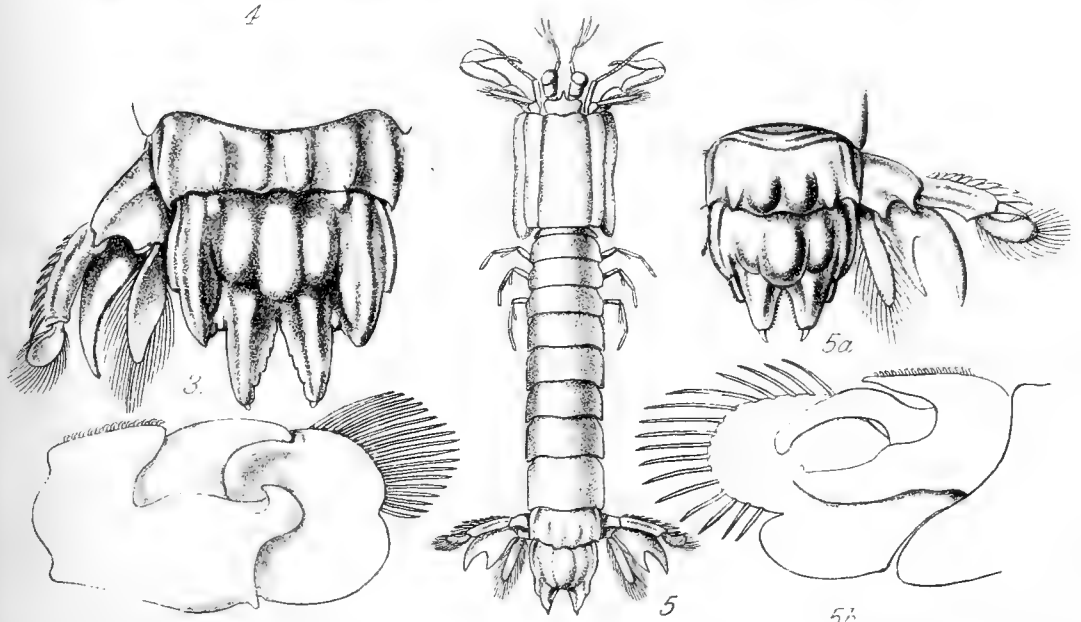
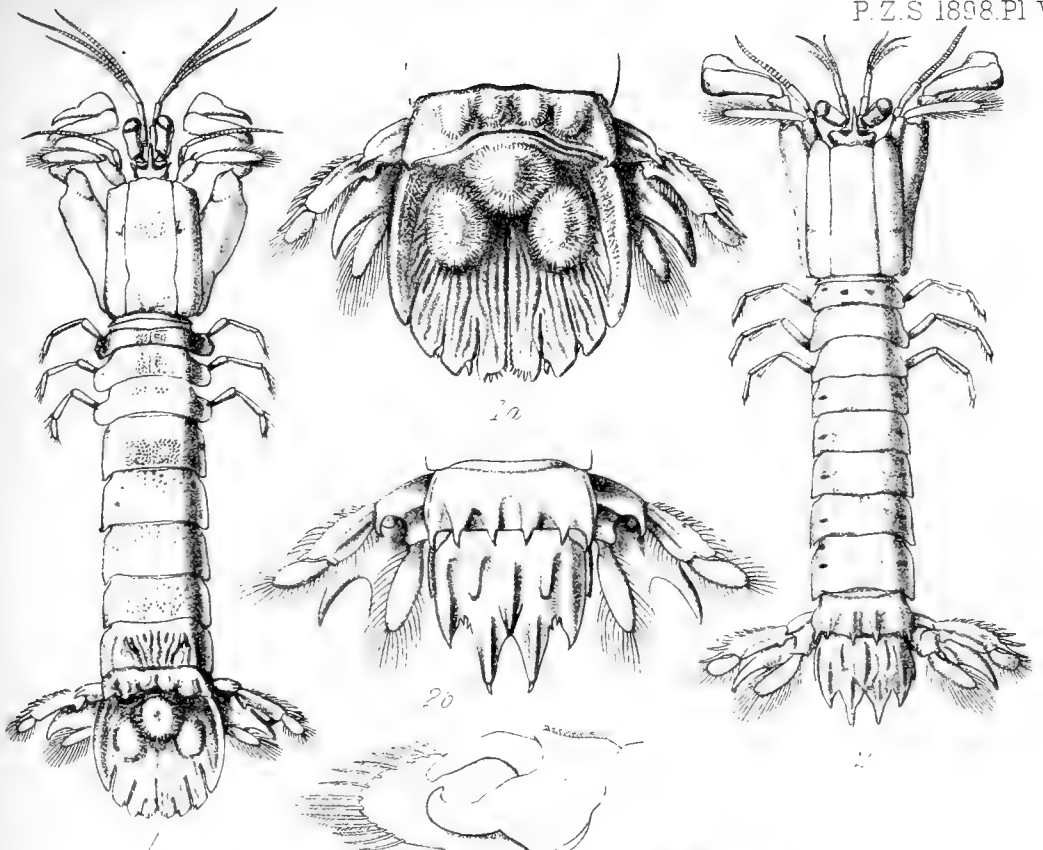

Edw. A. M. S. Cambridge



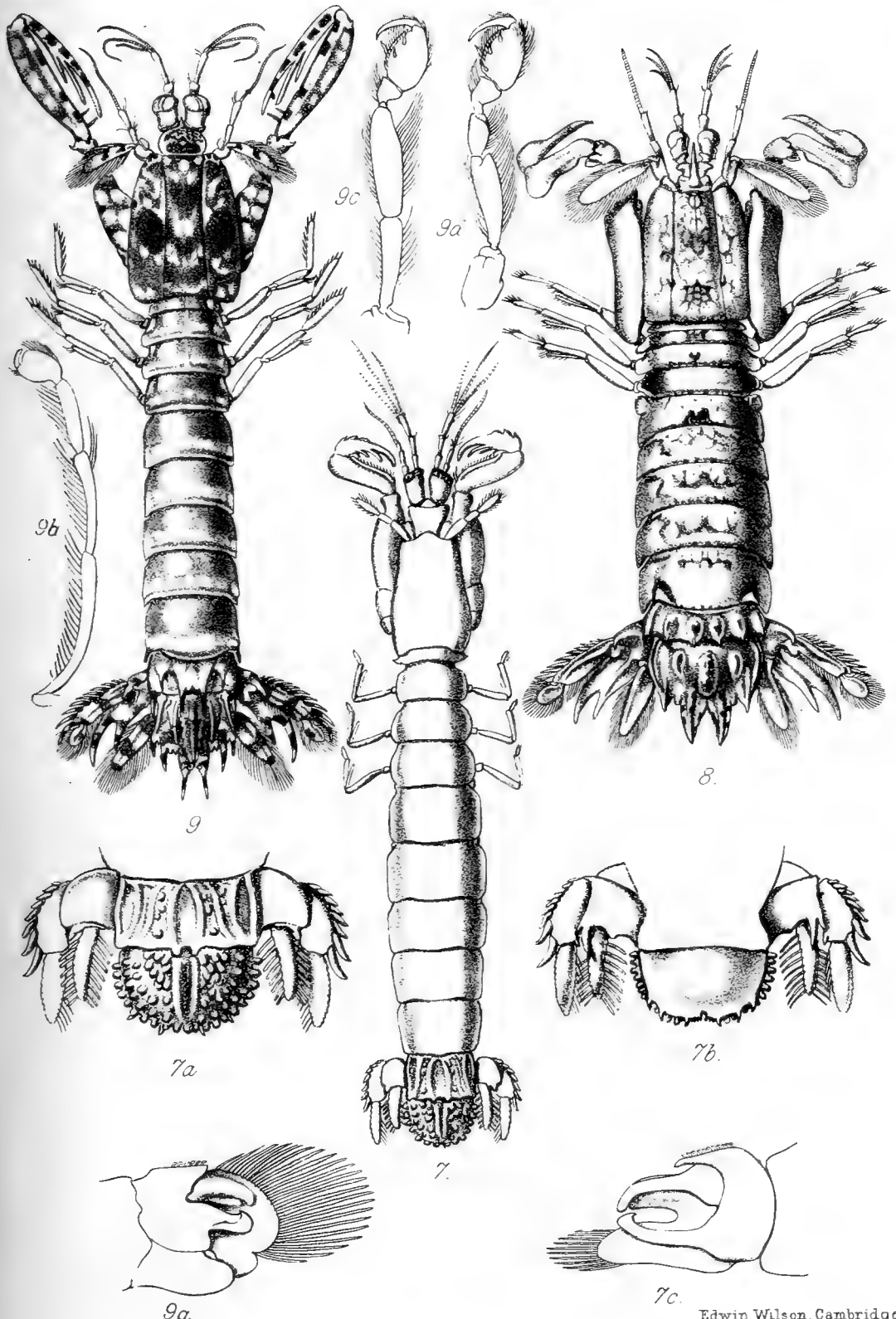

STOMATOPODA FROM THE SOUTH PACIFIC. Edwin Wilson. Cambridge.

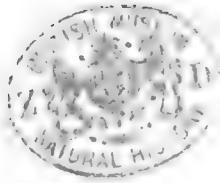

February 1, 1898.

Dr. ST. GEORGE MIVART, F.R.S., V.P., in the Chair.

Mr. Oldfield Thomas exhibited the skull of a Giraffe from West Africa, which, with its anterior cannon-bones, had been presented to the British Museum by Mr. W. Hume McCorquodale. The animal had been shot by that gentleman's brother, the late Lieut. Robert Hume McCorquodale, of the 3rd Dragoon Guards, to the south-east of the junction of the Benue and Niger, and came therefore from a district whence Giraffes had never hitherto been recorded. So far as could now be ascertained by the kind assistance of Sir G. Taubman Goldie, its locality was approximately 8° E., and 7° N., and therefore very far from any part of the known range of the genus. The nearest recorded locality seemed to be Lake Tchad, some 600 miles distant, whence Denham and Clapperton had obtained a young specimen formerly exhibited in the British Museum.

In determining the affinities of this skull, Mr. Thomas had been much aided by the clear disentanglement of the characters and synonymies of the Northern and Southern Giraffes in the paper recently read before the Society by Mr. De Winton¹. From this it appeared, as was natural, that the Nigerian skull was undoubtedly most nearly allied to that of the true Northern Giraffe, *Giraffa camelopardalis*; but on careful comparison it yet seemed so different in details that he thought it should be considered as representing a Western subspecies of that animal.

The skull was clearly, judging by its extreme lightness and fragility, that of a female, but was actually longer than any of the three fine male skulls, representing both Northern and Southern species, in the British Museum, and of course considerably longer than any female skull, there being a decided difference in size between the sexes. As another indication of the great size of this Giraffe, it might be noted that although its cannon-bones still had their epiphyses separate, their total length exceeded that of the cannon-bone (with ankylosed epiphyses) of a female Abyssinian Giraffe by nearly 3 inches, and scarcely fell short of that in an old male Giraffe from the same region. These differences in size are brought out by the measurements below.

In the form of the skull the most obvious and probably most important difference was to be found in the proportions of the face. While in the ordinary Giraffe the tapering forward of the face from the orbits to the muzzle was even and gradual, in the present skull it was exceedingly abrupt at first, from the very broad orbital region to a point above the anterior premolars; then from this point forward the muzzle was very narrow and slender, almost parallel-sided, broadening again in the region of the very large spatulate nasal opening. The latter opening, in its great length and breadth, was

¹ See P. Z. S. 1897, p. 275.

quite unlike that found in any other skull examined. As indications of the elongation of the face, the measurements given below of the muzzle anterior to the teeth and of the mandibular diastema might be specially noticed.

The horns were slender, as usual in the female, but their direction was doubly different from that normal, as they were widely divergent instead of parallel when viewed from in front, and, when viewed from the side, more vertically upright, instead of lying back in the plane of the forehead. The third horn, for a female, was well developed, its bony core forming an obviously distinct ossification on the top of the swollen frontals.

A large anteorbital vacuity was present on each side. There was also a peculiar smooth-edged vacuity, large enough to admit a human thumb, at the posterior edge of each squamosal, opening into the canal that terminates below in the postglenoid foramen. No trace of this vacuity was to be seen in other skulls, but although perfectly symmetrical on the two sides, it was rather doubtful whether it would prove to be more than an individual peculiarity.

On the lower side of the skull, apart from the striking difference in aspect produced by the long parallel-sided muzzle, there was little of importance to notice.

The following were the skull-measurements of Abyssinian and Nigerian Giraffes (in millimetres):—

	Old male, Abyssinia.	Adult female, Abyssinia.	Adult female, Nigeria.
Extreme length	670	613	715
Basal length	580	546	640
Greatest breadth	303	265	282
Nasal opening, length from gnathion to junction of nasals with premaxillæ.....	162	163	194
Do., breadth	68	65	67
Muzzle to orbit	380	354	416
Distance between tips of horns (centres).....	160	125	217
Muzzle to front of anterior premolar	245	230	270
Lower jaw, angle to front of bone	521	480	558
Do., diastema	190	178	220
Weight, with lower jaw	19 lbs. 8 oz.	7 lbs. 6 oz.	10 lbs. 7 oz.
Weight, without lower jaw		4 lbs. 11½ oz.	6 lbs. 10¼ oz.

The East-African skull obtained by Mr. Neumann, and described in Mr. De Winton's paper, weighed 22 lbs. 14½ oz. with, and 19 lbs. 6 oz. without the lower jaw.

Taking all the circumstances into consideration, Mr. Thomas considered that this fine animal might be provisionally assigned to the Northern species, *Giraffa camelopardalis*, of which it would form a Western subspecies, that might be termed *G. c. peralta*, on account of its superior height.

Mr. Thomas expressed his appreciation of the scientific spirit shown by Lieut. McCorquodale in preserving so clumsy and yet so

valuable a specimen, and of the generosity shown by his brother in presenting it to the National Collection.

It was much to be hoped that some of the many British officers now in Nigeria would bring home further spoils of this magnificent animal, so that zoologists might gain a better knowledge of its characters and relationships.

Mr. Sclater exhibited photographs of the Giraffe now living in the Society's Gardens, of the Giraffe presented to the Queen by Chief Bethoen of Bechuanaland, which had died in the Society's Gardens on the 20th of September shortly after its arrival, and of the pair of Giraffes now living in the Zoological Garden of Berlin (see P. Z. S. 1897, p. 813), in order to show the differences in markings between the two forms *Giraffa camelopardalis typica* and *G. c. capensis* (cf. De Winton, P. Z. S. 1897, p. 276).

The following letter from Mr. J. Graham Kerr, F.Z.S., dated from the Zoological Laboratory at Cambridge, January 28th, was read:—

“I have just received from my friend and correspondent in Paraguay, Mr. R. J. Hunt, a letter in which he gives most interesting information in regard to the dry-season habits of *Lepidosiren*. During my recent stay in the Gran Chaco I was able to definitely determine that *Lepidosiren*, like its African relative *Protopterus*, does retire into the mud at the commencement of the dry season, but I was prevented by the untimely onset of heavy rains from pursuing my enquiries further into the matter. On leaving the Chaco I left behind with Mr. Hunt a set of questions in regard to the so-called ‘cocoon,’ which he very kindly agreed to do his best to answer when the prolonged drought should provide the opportunity. The result is the very interesting communication which I enclose, and which will, I think, be of much interest to zoologists generally, providing as it does the first account of the dry-season cocoon of *Lepidosiren*. I need scarcely draw attention to the extraordinarily close agreement of *Lepidosiren* in many points of detail to what is already known to us in the case of *Protopterus*.”

Mr. Hunt writes as follows:—

“1. The nest made by the ‘Loläch’ in the dry season (see figs. 1-3, pp. 42, 43), so far as I can ascertain, seems to be quite distinct from the burrow in which the eggs are laid. On the rising of the water the beast comes out of its nest and seeks a convenient place to lay its eggs, which may be near to or far from its nest of the dry season. From the appearance of the inside of the nest, I should say that on the return of the dry season the Loläch does not return to the place that it used for the laying of its eggs, nor is there any sign of it near its dry-season nest.

“2. The entrance or exit of the nest is by the side of the roots of the papyrus (*pîrî*), the cutting swamp-grass, or the bulrush. The circular entrance, two and a half inches in diameter, is plugged

from the inside with a round piece of clay, hollow and smooth inside from the pressure of the *Loläch's* nose. Surface clay is employed to plug the entrance, and the only thing visible from the outside is this convex plug fitting into the rim of the round entrance, and sometimes, adjacent, another hole more or less filled up, often entirely so, and consequently invisible, where the beast first entered the earth. The original entrance is sometimes used (perhaps most generally used) for the door of the finished nest. The outside plug is pierced with two or three round holes, very small as if formed by a big worm, and in which a peppercorn could be tightly fitted. These are evidently formed by the placing together of the pieces of clay, because in the inside (which is smooth and concave) the hole is not round but slit-like, showing the joining. This is not always the case. Some are round inside as on the convex side. The inside of the plug is slightly damp and slimy, but tasteless.

Fig. 1.

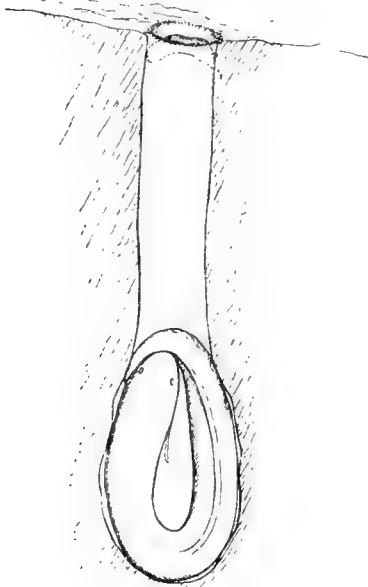

Fig. 2.



Views of two dry-season burrows of *Lepidosiren*, as seen in section.

“On removing the outer plug, a long crooked channel appears, about two and a half or three inches in diameter, leading without obstruction to the creature's bed. This channel, like the inside of the plug, is moist and slimy, the moisture increasing in amount as it reaches the head of the beast. The channel varies in length from twelve to twenty inches. In the case of a long channel, several plugs are employed, at every four or six inches. In one nest five plugs were found. The first three were like the one at the entrance; the breathing-holes small and round on the outside but not always round inside, the slit varying in size from a quarter

to three-quarters of an inch. The last one close to the head of the Loläch had the appearance of being unfinished. It had the usual two round holes—a slit, and in the centre a circular opening an inch in diameter.

“3. The inside of the ‘cocoon’ contains no grass or weeds, but is damp and slimy like the channel leading to it, only very much damper, and the sides are lined with a gelatinous but tasteless substance, and on the removal of the beast from its sleeping-place, the moisture is visible, congregated at the foot of the nest in a very small quantity. There is very little space between the walls of the nest and the animal itself, especially near the head. The foot of the nest is deeper, but nothing but firm clay lined with this slimy, sticky, gelatinous fluid already mentioned.

Fig. 3.

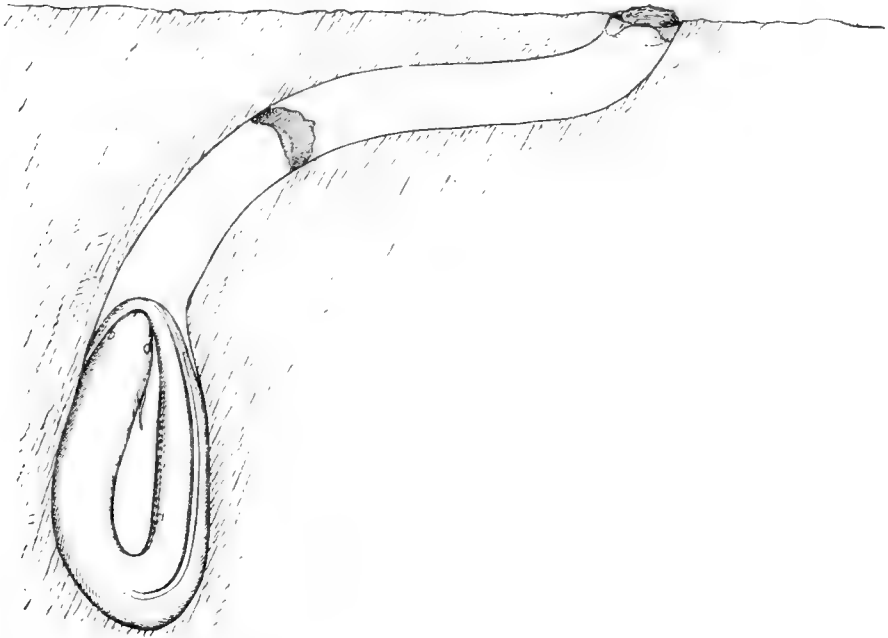

View of a dry-season burrow of *Lepidosiren*, as seen in section.

“4. The average size of the cocoon in which the Loläch sleeps is 14×6 inches. It is oblong in shape, about six inches at the foot and three or four inches at the mouth in width.

“The specimens I personally took from the cocoons were all full-grown ones, but the Indians have caught young ones, an inch in diameter and about a foot long, in their nests.

“5. The nest varies in depth from the surface from fourteen to twenty inches. It is slanting, the head sometimes being four inches higher than the bottom of the nest. The Loläch lies on his belly and chin, his tail is brought over the right eye and round the mouth, so covering the whole face. The head is of course nearest to the opening.

"6. When seen in the nest the Loläch is of a light brownish colour, its skin is soft and slimy, being coated with a similar substance to that with which it lines the clay walls of its house. On being exposed to the light, it soon becomes dark coloured and the skin dry and hard.

"7. No signs whatever of a tube of gelatinous material appear either in the nest or in the channel leading outward to the opening, and the lips of the fish seem to be completely covered with the tail that is brought over the mouth.

"8. The centre of the swamp, where the deepest water is, seems to be a more favoured part for the nests than in the shallow coasts. One nest that I dug out had an exceedingly long and tortuous channel, the bottom of the nest being twenty inches below the surface and three feet away from the opening. I believe it to be an exception.

"On the rising of the water they push out the plug, and remain for a little while with their noses out, before they finally leave their winter home."

Mr. G. A. Boulenger, F.R.S., gave an account of the Fishes collected by Dr. J. Bach in the Rio Jurua, Brazil. Fifty-one species were enumerated, of which nine were described as new, and named as follows:—*Platystoma juruense*, *Oxydoras trimaculatus*, *O. trachyparia*, *O. bachi*, *O. elongatus*, *Chaetostomus bachi*, *Acestra gladius*, *Cetengraulis juruensis*, and *Sternarchus tamandua*.

This paper will be published in full in the Society's 'Transactions.'

The following papers were read:—

1. On the Anatomy of an Australian Cuckoo, *Scythrops nova-hollandiæ*¹. By FRANK E. BEDDARD, M.A., F.R.S., Prosector to the Society.

[Received December 7, 1897.]

So far as I can discover there is no account extant of the structure of the soft parts of *Scythrops nova-hollandiæ*, save a few very brief notes on a "Bird, of the Toucan-kind, from New Holland," by John Hunter², and some facts concerning the pterylosis by Nitzsch³. Certain parts of the skeleton, on the other hand, are dealt with in Eyton's 'Osteologia Avium,' and the skull has been described by Parker⁴.

¹ I am indebted for the specimens, upon the examination of which this communication is founded, to the kindness of Mr. A. J. North, C.M.Z.S., of the Australian Museum.

² 'Essays and Observations, &c.,' ed. by R. Owen, London, 1861, vol. ii. p. 286.

³ 'Pterylography,' Engl. ed. by Sclater, Ray Soc. Publ.

⁴ Trans. Linn. Soc. (2) vol. i.

§ *External Characters and Pterylosis.*

This Cuckoo has a small nude oil-gland. There are 10 rectrices. The fifth remex is not missing; the bird is therefore quincubital. The pterylosis has, as already mentioned, been described by Nitzsch; and I have not much to add to his account. The ventral tract, however, appears to me to bifurcate at the commencement of the breast; each half then, as in *Centropus* &c.¹, again divides into an inner and outer branch. I find these two branches more distinct than they are figured by Nitzsch, while their point of rejunction is beyond the posterior margin of the sternum and is not very conspicuous. On the dorsal surface of the body the median apterion is distinct but narrow; there is no break between the anterior and posterior portions of the dorsal tracts, such as occurs in some Cuckoos.

§ *Muscular Anatomy.*

In dissecting the muscles of this bird the first point to which I attended was the arrangement of the *muscles of the thigh*. Garrod² divided the Cuculidæ into two groups, one with the muscular formula ABXY+, the other with the reduced formula AXY+. Garrod's list was afterwards extended by myself³. *Scythrops* belongs (as I expected that it would, after an examination of the pterylosis) to the former group. It has the complete muscle-formula, both femoro-caudal and accessory femoro-caudal being large and fleshy. They fuse early and are inserted in common.

The *ambiens* is large and conspicuous.

The *glutæus primus* extends beyond the acetabulum.

There is one other point in the structure of the hind limb to which I desire to direct attention. Garrod⁴ described the *deep flexor tendons* of the Cuculidæ as "Gallinaceous," *i. e.* the tendon of the flexor longus hallucis is united to the common tendon of the flexor profundus by a vinculum. This statement has been copied as applying generally to the Cuckoos. It does certainly apply to a large number, including *Scythrops*. But the late W. A. Forbes found that in *Centropus* and *Pyrrhocentor* the flexor longus hallucis is totally absent.

As to the muscles of the fore limb I have nothing of interest to record. The *tensor patagii brevis* tendon is simple and undivided; it is reinforced by no biceps slip.

The *expansor secundariorum* is present. The *anconæus longus* sends off a tendinous slip to the humerus as in most Cuckoos.

§ *Visceral Anatomy.*

On opening the body-cavity of *Scythrops* an arrangement of

¹ Beddard, "On the Structural Characters and Classification of the Cuckoos," P. Z. S. 1885, p. 168.

² "On certain Muscles of the Thigh of Birds, &c.," P. Z. S. 1873, p. 626.

³ *Loc. cit.*

⁴ "On the Disposition of the Deep Plantar Tendons in different Birds" P. Z. S. 1875, p. 339.

certain of the membranes partitioning the cœlom was observed that is not at all common among birds. The two liver-lobes were concealed behind transverse partitions extending across the body-cavity. On the right side of the body the partition was denser than on the left, with tough strands of connective tissue running in it. Anteriorly these vertical transverse partitions are attached, like the oblique septa and the umbilical ligament, to the pericardium. A structure of this kind seems to have been up to the present only met with in certain Picarian birds, in Owls and in Parrots. It seems now to be the prevalent opinion that the Owls, Parrots, and Coccoyges are not so far away from the Pico-Passerine division as Garrod attempted to prove.

As to the *alimentary tract* the gizzard is large; the intestines are capacious but short, the measurements being as follows:—Large intestines 4·5 inches; small intestines 20 inches; cæca 6·5 inches.

Of the two lobes of the liver the right is very much the larger. There is a gall-bladder.

The organ of chief classificatory importance, however, among the viscera is the *syrinx*. The syrx is of quite the typical tracheo-bronchial form, the intrinsic muscles being attached to the second bronchial semiring. The *membrana tympaniformis* is well developed. The *bronchidesmus* is incomplete, *i. e.* it does not extend up to the junction of the bronchi.

The structure of the syrx, therefore, combined with the characteristics of the pterylosis and the muscles of the leg, shows that *Scythrops* is an ally of *Eudynamis* and *Phœnicophaes*.

§ *The Skeleton.*

The skull of *Scythrops* has been studied by the late Prof. Parker¹, who, however, did not compare it much with the skull of other Cuckoos. I have compared *Scythrops* with the following genera: *Cuculus*, *Coccytes*, *Centropus*, *Pyrrhocentor*, *Crotophaga*, *Saurothera*, *Piaya*, *Gaira*, *Geococcyx*, *Diplopterus*, *Eudynamis*, *Phœnicophaes*, and *Rhinococcyx*.

The skull is not only larger than in any of the Cuckoos mentioned, but it is more massively constructed. This is seen especially in the face region. The external parts, for instance, are more reduced than in any other Cuckoo. In no Cuckoos are the external nares extensive, and in all they are impervious save in *Cuculus* and *Pyrrhocentor*, where the osseus septum is partly defective. In *Scythrops* they are relatively very small round orifices, immediately and almost completely occluded by a flap of bone running obliquely inward. In *Crotophaga* the nares are nearly as much reduced.

The massiveness of the skull is also seen in the interorbital septum, which is complete, save that the optic foramina are fused into one. In all other Cuckoos there are one or more vacuities in the bony wall. The large massive bill has also brought about a

¹ *Op. cit.*

more than usually strongly desmognathous palate (fig. 1). The maxillo-palatines are fused for their entire length, though grooved and even fenestrated in the middle. The palatines are completely fused together posteriorly, where the external lamina is absent. In front the two bones gradually get broader and diverge from

Fig. 1.

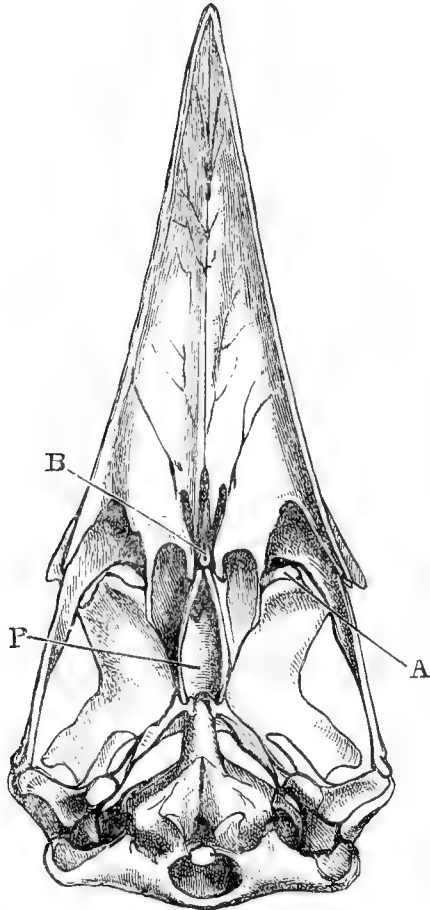
Skull of *Scythrops*, ventral view.

A, os uncinatum; B, vomer; P, junction of palatines.

each other. The internal edges of the palatines converge in front and nearly meet where a small splint of bone (a vomer) is wedged between them. The palatine bones are very deep, the ascending lamina being large. The pterygoids are hammer-shaped bones, their junction with the palatines being expanded in a vertical direction.

In other Cuckoos the palatines have not a well-developed ascending lamina, there is no fusion posteriorly or approximation

anteriorly between these bones (see fig. 2), while they diminish instead of slightly increasing in diameter from behind forward. Finally, the pterygoids are not expanded in other Cuckoos in a vertical direction at their junction with the palatines, and the

Fig. 2.

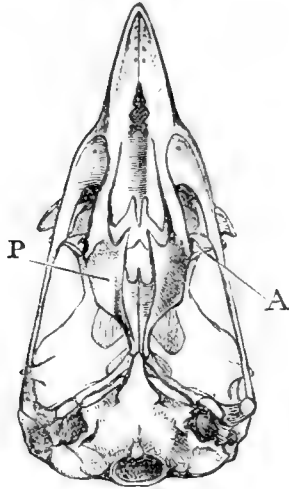
Skull of *Eudynamis*.

A, os uncinatum ; P, palatine.

maxillo-palatines are incompletely fused behind. The lacrymal bones in *Scythrops* are large, the descending process nearly reaching the jugal ; between the descending limb of the lacrymal and the massive ectethmoid process is an intercalated bonelet—the *os uncinatum*, duly referred to by Parker. I have found these bones also in *Eudynamis*¹ (cf. figs. 3 & 4, p. 49), where they are larger than in (my specimen of) *Scythrops* and very nearly reach the palatines. Shufeldt has denied their existence in *Geococcyx*².

Among the other genera of Cuckoos that I have examined it is only *Eudynamis* and certain other American genera (viz. *Crotophaga*, *Guira*, *Diplopterus*, and *Geococcyx*) that have a massive descending process of the lacrymal.

In *Saurothera* and in other Old World genera³ this process is short, or, if long, a slender style.

Scythrops has fourteen cervical vertebræ, of which the last three bear ribs progressively increasing in size, those on the 12th being

¹ I take this opportunity of mentioning that *Eudynamis* has better rudiments of basipterygoid processes than any Cuckoo which I have examined, except *Rhinococcyx*. This is noteworthy in view of the possibly archaic characters of the Phœnicophainæ with complete muscular formula of leg and tracheo-bronchial syrinx.

² "Contributions to the Anatomy of *Geococcyx californianus*," P. Z. S. 1886 p. 488.

³ ? as to *Centropus*.

very minute. Contrary to what is found in many Cuckoos¹ the atlas is notched, not perforated, for the odontoid process; the notch,

Fig. 3.

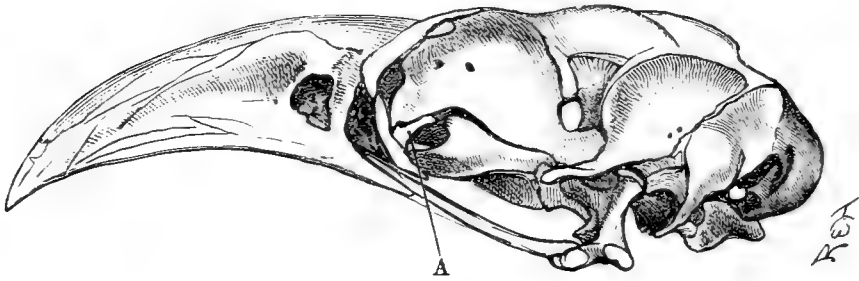

Skull of *Scythrops*, lateral view.
A, os uncinatum.

Fig. 4.

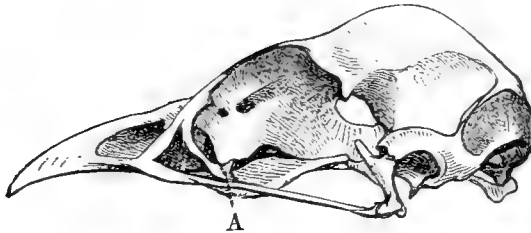

Skull of *Eudynamis*, lateral view.
A, os uncinatum.

however, is very nearly converted into a perforation. Four ribs reach the sternum, the vertebra bearing the last complete rib being the last free dorsal.

2. On a Collection of Lepidoptera made by Mr. F. V. Kirby, chiefly in Portuguese East Africa. By ARTHUR G. BUTLER, Ph.D., F.L.S., F.Z.S., &c., Senior Assistant-Keeper, Zoological Department, British Museum.

[Received November 29, 1897.]

The collection of which the following is an account is chiefly of interest because of the care with which most of the specimens have been labelled, and from the fact that the supposed dry- and wet-season forms of some of the species were both secured. There are also several forms which are by no means common in collections, and an interesting extreme form of *Alcena nyassæ*, var. *ochracea*,

¹ *Rhinococcyx*, *Cuculus*, *Saurothera*. In *Eudynamis*, *Guira*, and *Diplopterus* there is a notch nearly converted into a foramen.

very deep in colouring, with the ochreous belt of the primaries united to a spot of this colour within the discoidal cell and that of the secondaries covering almost the entire basal two-thirds of these wings.

The following is a list of the species:—

RHOPALOCERA.

NYMPHALIDÆ.

1. *AMAURIS ECHERIA* Stoll.
Eastern Transvaal and Portuguese East Africa.
2. *AMAURIS ALBIMACULATA* Butl.
Eastern Transvaal.
3. *AMAURIS OCHLEA* Boisd.
Eastern Transvaal, and Shiringoma and Makaya districts, (Portuguese East Africa), November 1896.
4. *LIMNAS CHRYSIPPUS* Linn.
Eastern Transvaal, Nyakongoli, Makoto, August 21st; Shiringoma and Makaya districts, November 1896 and January 1897.
5. *GNOPHODES DIVERSA* Butl.
Inure; Patawali, 27th August, 1897.
6. *MELANITES LIBYA* Dist.
Inure.
7. *MELANITIS SOLANDRA* Fabr.
Inure; Mkanga Mivana, 10th September, 1896.
Both wet and dry forms were obtained; the specimens (dry-season) from Mkanga Mivana were terribly shattered, having probably been long on the wing.
8. *SAMANTA PERSPICUA* Trim.
Inure.
Wet, intermediate, and dry forms were obtained, the last being my *S. simonsi* and thus proving the correctness of Mr. Marshall's supposition. In the intermediate form, however, the fulvous colouring of *S. simonsi* is only indicated on the ocelliferous area of the wings.
9. *MYCALESIS SAFITZA* Hewits.
Eastern Transvaal and Inure.
Wet, intermediate, and dry-season examples were obtained; *S. caffra* is represented by the intermediate form.
10. *PHYSCÆNURA PIONE* Godm.
Inure.

11. *YPTHIMA PUPILLARIS* Butl.

Inure (dry-season form).

The ocelli are reduced to points on the under surface.

12. *EURALIA WAHLBERGI* Wallgr.

Makaya district, January and February 1896; Inure.

The specimens are a good deal worn.

13. *EURALIA KIRBYI* sp. n.

Nearest to *E. deceptor*, but in the character of the white markings reminding one of *Panopea delagoæ*, the belt crossing the median vein of primaries being narrower and barely visible above the second median branch; the subapical belt also decidedly narrower, so that the space between the two belts is of nearly double the width; the other white spots on these wings similarly placed to those in *E. deceptor*, but that towards the base of the cell much smaller; the belt across the secondaries narrower and whiter; the outer border consequently half as wide again as in *E. deceptor*, the subapical series of white spots very small or wanting, and the submarginal spots small and squamose; below the differences are similar, the costal area of secondaries being much browner. Expanse of wings 87 millimetres.

Shiringoma and Makaya districts, November 1896.

This is doubtless a representative form of *E. deceptor*, but differs quite as much in character as any of the other described species of its genus, excepting perhaps *E. usambara* of the *E. anthedon* group and *E. mechowii* of the *E. dinarcha* group.

14. *HYPOLIMNAS MISIPPUS* Linn.

Shiringoma and Makaya districts, November 1896.

15. *CHARAXES VARANES* Cram.

Makaya district, January and February 1896.

16. *JUNONIA ACTIA* Dist.

Chiperoni, Portuguese Central Africa, September 1896.

17. *JUNONIA CUAMA* Hewits.

Chiperoni, September 1896, and Inure.

18. *JUNONIA ELGIVA* Hewits.

Eastern Transvaal; Chiperoni, September 1896; Shiringoma and Makaya districts, November 1896; Inure.

19. *JUNONIA ARTAXIA* Hewits.

Chiperoni, September and October; Shiringoma and Makaya districts, November 1896.

20. *JUNONIA CLELIA* Cram.

Eastern Transvaal, and Inure, Portuguese East Africa.

21. JUNONIA BOOPIS Trim.

Nyakongoli, Makoto, August 21st ; Chiperoni, September 1896.

22. PROTOGONIOMORPHA ANACARDII Linn.

Eastern Transvaal and Portuguese East Africa.

23. PROTOGONIOMORPHA AGLATONICE Godt.

Inure.

The vars. *aglatonice* and *nebulosa* were both obtained.

24. PYRAMEIS CARDUI Linn.

Eastern Transvaal.

25. EURYPHURA ACHLYS Hopff.

♂. Chiperoni, Portuguese Central Africa, September 1896.

26. EURYPHENE SENEGALENSIS Hübn.

♀. Chiperoni, October 1896.

27. ATERICA GALENE Brown.

Patawali, Portuguese East Africa, 27th August, 1897.

Only one much damaged male of this species was obtained.

28. EUPHÆDRA NEOPHRON Hopff.

Portuguese East Africa.

No exact locality is given on the envelope.

29. CRENIDOMIMAS CONCORDIA Hopff.

♀. Patawali district, Portuguese East Africa.

The single example obtained corresponds exactly with Hopffer's figure in the colouring of the upper surface, but the innermost row of black spots on the secondaries is absent (as is sometimes the case in the nearly allied *C. crawshayi*): on the under surface the colouring is a little deeper than in the figure; but, as I pointed out when comparing *C. crawshayi* with Hopffer's figures, the blue spots on the primaries (excepting at apex) are not connected with the blue outer border; on the other hand this border is not continuous on the primaries as represented in Hopffer's description and figure. In some of the characters which distinguish *C. crawshayi* from *C. concordia* the present specimen therefore seems to be intermediate, though the more varied and blue-tinted upper surface with the wider bifid whitish subapical bar give it a different aspect from any of the females of the Nyasa type; so that, until the separation of the spots from the border on the under surface has been proved to be variable, the two forms must still be kept apart.

30. CRENIS BOISDUVALI Wallgr.

Eastern Transvaal.

The example now received agrees most nearly with one which

we received from Zomba in 1895, and differs about as much as the other forms to which names have been given recently; but considering that the majority of them occur in Natal, there can be little doubt that they are either seasonal forms or sports of two or three variable species at most. We received typical *C. boiscuvali* from Zomba in 1893.

31. NEPTIS AGATHA Cram.

Chirimani, Portuguese East Africa, August 31st in open forest; Inure; Chiperoni, Portuguese Central Africa, October 1896.

The variation in size of this species is extraordinary; the Chiperoni example has an expanse of 70 millimetres.

32. ATELLA PHALANTHA Drury.

Eastern Transvaal and Portuguese East Africa.

Both the wet-season form (*A. columbina*) and the dry form (*A. phalantha*) were obtained.

33. BYBLIA ACHELOIA Wallgr.

Eastern Transvaal; Inure; Chiperoni, September 1896.

The typical dry form and the wet-season *B. vulgaris* were both obtained.

34. EURYTELA DRYOPE Fabr.

♂. Inure.

35. ACRÆA CABIRA Hopff.

Inure.

The specimens all have the pattern of the variety *apecida*.

36. ACRÆA SERENA var. BUXTONI Butl.

♂. Portuguese East Africa.

37. ACRÆA LYCIA Fabr.

Eastern Transvaal and Nyakongoli; Makoto, Portuguese East Africa, 21st August.

Only two examples without head or abdomen.

38. ACRÆA DOUBLEDAYI Guér.

Eastern Transvaal; Chiperoni, October 1896; Nyakongoli, 21st August.

39. ACRÆA NATALICA Boisd.

Nyakongoli, 21st August.

40. ACRÆA ACBITA Hewits.

Eastern Transvaal; Nyakongoli, 21st August; Chirimani, 31st August; Chiperoni, September 1896; Patawali district in open bush country and plantations.

41. ACRÆA AGLATONICE Westw.

♀ ♀. Portuguese East Africa (exact locality not noted).

42. *ACRÆA ANEMOSA* Hewits.

Nyakongoli, 21st August; Shiringoma and Makaya districts,
November 1896.

LYCÆNIDÆ.

43. *ALÆNA NYASSÆ* var. *OCHRACEA* Butl.

Inure.

A very interesting form of this variety.

44. *POLYOMMATUS BÆTICUS* Linn.

Inure; Chiperoni, September 1896.

45. *CATOCHRYSOPS OSIRIS* Hopff.

Eastern Transvaal and Portuguese East Africa.

46. *CATOCHRYSOPS PATRICIA* Trim.

♂. Chiperoni, October 1896.

A curious aberration with white-edged elongated blackish spots
across the disc of the wings.

47. *TARUCUS PLINIUS* Fabr.

Inure.

48. *CACYBEUS LINGEUS* Cram.

Patawali, in plantations.

49. *ZERITIS HARPA* Fabr.

Eastern Transvaal.

50. *CRUDARIA LEROMA* Wallgr.

Inure.

51. *MYRINA FICEDULA* Trim.

Eastern Transvaal.

52. *VIRACHOLA ANTALUS* Hopff.

Inure.

53. *IOLAUS PHILIPPUS* Fabr.

Eastern Transvaal and Inure.

54. *IOLAUS BUXTONI* Hewits.

♀. Chiperoni, September 1896.

55. *IOLAUS PALLENE* Wallgr.

Chiperoni, September 1896.

56. *STUGETA BOWKERI* Trim.

Inure.

PAPILIONIDÆ.

57. MYLOTHRIS AGATHINA Cram.

Eastern Transvaal, Nyakongoli, August 21st; Chirimani, August 31st.

58. NYCHITONA MEDUSA var. ALCESTA Cram.

Portuguese East Africa.

I believe this genus consists of one variable species, but the variations of the African and Mascarene examples are somewhat different from those of Asia and Australasia, so that there is some excuse for keeping them separate.

59. TERIAS BRIGITTA var. ZOE Hopff.

Eastern Transvaal.

60. TERIAS MARSHALLI Butl.

♀. Patawali, Portuguese East Africa.

A small example of the intermediate-season form.

61. TERIAS HAPALE var. ÆTHIOPICA Trim.

Patawali and Inure.

62. TERACOLUS REGINA Trim.

♂ ♀. Wet form, Makaya district, January and February 1896.

♀. Dry form, Shiringoma and Makaya districts, November 1896.

The female of the wet form (*T. anax*) is, though rubbed, a new variety to me, the usual white spots on the apical area of the primaries being replaced by spots of rosy violet.

63. TERACOLUS IONE Godt.

♀ ♀. Portuguese East Africa, Makaya district, January and February 1896.

64. TERACOLUS SIPYLUS Swinh.

♂ ♂. Portuguese East Africa (no exact locality noted).

65. TERACOLUS ITHONUS Butl.

♂. Nyakongoli, Makoto, August 21st; ♀. Patawali.

The male (var. *ignifer*) is too much injured to be fit for the collection; the female is a starved intermediate-season form.

66. TERACOLUS OMFHALE Godt.

Eastern Transvaal.

67. TERACOLUS MUTANS Butl.

♀. Portuguese East Africa (wet-season).

68. CATOPSILIA FLORELLA Fabr.

Nyakongoli, August 21st; Chiperoni, October; Shiringoma and Makaya districts, November 1896 and January 1897.

69. BELENOIS THYSA Hopff.

Nyakongoli, August 21st.

70. BELENOIS SEVERINA Cram.

Eastern Transvaal; Portuguese East Africa, Patawali district.
The wet form (*B. infida*), the intermediate form, and the dry form (*B. severina*) are all represented.

71. BELENOIS MESENTINA var. LORDACA Walk.

♀. Portuguese East Africa.

72. BELENOIS ZOCHALIA Boisd.

♀. Dry-season form, Chirimani, August 31st.

73. LEUCERONIA ARGIA Fabr.

Shiringoma and Makaya districts, November 1896.

74. PAPILIO NYASSÆ Butl.

Makaya district, January and February 1896.

75. PAPILIO POLISTRATUS Grose-Smith.

♀. Makaya district, January or February 1896.

Differs from the illustration of the male in its greater size; the pale markings on the primaries, excepting at external angle, are much broader; the markings on the basi-abdominal half of the secondaries are also broader, but the crescentic markings above the tail are very indistinct.

76. PAPILIO CORINNEUS Bertol.

Inure, Nyakongoli, August 21st; Shiringoma and Makaya districts, November 1896 and January 1897.

77. PAPILIO LEONIDAS Fabr.

Makaya district, January and February 1897.

78. PAPILIO DEMOLEUS Linn.

Eastern Transvaal, Makaya district, January and February 1897.

79. PAPILIO ERINUS Gray.

Eastern Transvaal, Makaya district, January and February 1896.

80. PAPILIO MEROPE var. DARDANUS Brown.

Makaya district, January and February 1896.

HESPERIIDÆ.

81. TAGIADES FLESUS Fabr.

Patawali.

82. *ERETIS DJÆLÆLÆ* Wallgr.

Portuguese East Africa (exact locality not noted).

83. *ANDRONYMUS PHILANDER* Hopff.¹

Chiperoni, September 1896.

84. *BAORIS NETOPHA* Hewits.

Chiperoni, September 1896.

Corresponds nearly with Trimen's figure of *B. roncilgonis* above and with Karsch's colouring of *B. cojo* below. Two examples which we have from Fwambo, Tanganyika, have the under surface mostly bright ochreous and scarlet, but with the same markings exactly as in *B. roncilgonis*.

85. *RHOPALOCAMPTA PISISTRATUS* Fabr.

Portuguese East Africa (no exact locality noted).

HETEROCERA.

ARCTIIDÆ.

86. *DEIOPEIA PULCHELLA* Linn.

Eastern Transvaal and Inure.

87. *ALETIS MONTEIRONIS* Druce.

♀. Portuguese East Africa.

88. *LEPTOSOMA LEUCONOE* Hopff.

Inure.

¹ I take this opportunity of describing a beautiful new species of *Cyclopides* from Fwambo, Tanganyika, collected by Mr. A. Carson:—

CYCLOPIDES CARSONI sp. n.

Nearest to *C. perexcellens*, the wings slightly broader in proportion to their length; the upper surface of a somewhat deeper olive-brown, the fringe of the primaries ochreous at external angle; no ochreous spots in the discoidal cell; the spots on the disc larger, the three uppermost (bifid) spots much paler; the fringe of the secondaries varied with dark brown: on the under surface of the primaries there is a well-defined pale ochreous streak above the cell from base to middle of wing, but no ochreous spot within the cell; the three uppermost discal spots as above, but the lowest spot very small; the secondaries below are cream-coloured with slight silvery reflections; the veins and outer margin black, but not the abdominal margin; a costal streak to middle, a quadrate patch from costal to subcostal vein above the cell, two similar patches placed obliquely above each of the subcostal branches, a quadrifid band from second subcostal branch across the end of the cell almost to the submedian vein and a quinquefid submarginal band between the same veins, deep ochreous bordered with black; a squamose pale ochreous longitudinal submedian streak, broadly interrupted by blackish brown, from the extremities of the two transverse deep ochreous bands to the submedian vein. Expanse of wings 34 millimetres.

Three males in the British Museum collection.

A G A R I S T I D Æ.

89. XANTHOSPILOPTERYX SUPERBA Butl.
Shiringoma and Makaya districts, November 1896.

N O C T U I D Æ.

90. TÆNIOPYGA SYLVINA Stoll.
Chiperoni, September 1896.

H Y P S I D Æ.

91. EGYBOLIA VAILLANTINA Stoll.
Inure.

G E O M E T R I D Æ.

92. COMIBÆNA LEUCOSPILATA Walk.
Portuguese East Africa (exact locality not noted).

3. On the Vascular System of the Chiroptera. By N. H. ALCOCK, B.A., M.D., Assistant to the Professor of Institutes of Medicine, Trinity College, Dublin¹.

PART I.—Thoracic Vessels of *Pteropus medius*; with a Summary of the Literature of the Chiroptera.

[Received October 13, 1897.]

The anatomy of the Chiroptera has been the subject of many and interesting researches. Dobson², in addition to numerous

¹ Communicated by Prof. G. B. HOWES, F.R.S., F.Z.S.

² DOBSON, G. E.—'Catalogue of the Chiroptera in the British Museum,' 567 pp., 30 pls.; London, 1878 (contains many references, chiefly to systematic papers). 'Monograph of the Asiatic Chiroptera' (includes European forms); London, 1876. "Secondary Sexual Characters in the Chiroptera," Proc. Zool. Soc. 1873, pp. 241-252. "On the Structure of the Pharynx, Larynx, and Hyoid Bones in the Genus *Epomophorus*," *loc. cit.* 1881, pp. 685-693. "Monograph of the Group *Molossi*," *loc. cit.* 1876, pp. 701-735. "Structure of Feet, Claws, and Wing-membrane of *Mystacina tuberculata*," *loc. cit.* 1876, pp. 486-488. "Monograph of the Genus *Taphozous*," *loc. cit.* 1875, pp. 546-556. "On Peculiar Structures in the Feet of certain Mammals, which enable them to walk on smooth perpendicular surfaces," *loc. cit.* 1876, pp. 526-535, pl. lv. (*Vesperugo*, *Mystacina*, *Thyroptera*, *Hyrax*). "On the Phalaux missing from certain Digits in the Manus of Chiroptera," Journ. Anat. Phys. xvi. p. 200. "Osteology of *Triænops persicus*," Journ. Asiatic Soc. Bengal, xli. pp. 136-142, pl. vi. "Chiroptera in Genoa Civic Museum etc.," Ann. Mus. Genov. (2) ii. pp. 16-19. "Report on Accessions to our Knowledge of the Chiroptera etc. in 1878-1880," Rep. British Assoc. 1880, pp. 169-197. "Geographical Distribution of Chiroptera," *loc. cit.* 1878, pp. 158-167. "Chiroptera in Göttingen Museum," Bull. Soc. Zool. France, 1880, pp. 232-239. "*Pteropus rodericensis*," Phil. Trans. clxviii. p. 457. "Conspectus of Sub-orders, Families, and Genera of Chiroptera, arranged according to their natural affinities," Ann. N. H. (4) xvi. pp. 345-357, and additional remarks, *loc. cit.* (4) xviii. pp. 345-347.

minor papers, has described the general anatomy of the Order, with a complete systematic arrangement of all the known genera and species, up to the year 1878. In more recent times Allen¹ has done the same for the North-American Bats. Macalister², in an able and comprehensive paper, has recorded the comparative anatomy of the muscles of the group; and Maisonneuve³ has given a complete account of the myology and osteology of *Vespertilio murinus*. Robin⁴ treats of the respiratory, digestive, and genito-urinary organs of the Order; and the embryological researches of Van Beneden and Julin⁵ on the formation of the amnion here and in the Mammalia generally are well known. But with the exception of Röse⁶, who, in his paper "Beiträge zur vergleichenden Anatomie des Herzens der Wirbelthiere," incidentally refers to the heart of *Pteropus poliocephalus* and *Vespertilio* (*Myotis*) *murinus*, and Hyrtl⁷, who in 1864 described the arrangement of some of

¹ ALLEN, H.—"A Monograph of the Bats of N. America," Bull. U.S. Nat. Museum, No. 43, Washington, 1893, 193 pp., 37 pls. See also Washingt. Smiths. Inst. 1864, 8vo, 85 pp., woodcuts. Introduction to Monograph (1893), in P. U.S. Mus. xvi. pp. 1-28. "On the Molars of Pteropine Bats," Proc. Ac. Nat. Sci. Philadelphia, 1892, pp. 172-173. "Colour-marks in the Pteropodidae," *loc. cit.* 1890, pp. 12-30. "Note on the Mammary Glands of Bats," *loc. cit.* 1880, p. 133. "Note on the number of the Phalanges of Bats," *loc. cit.* 1880, p. 359. "On the Temporal and Masseter Muscles of Mammals," *loc. cit.* 1880, pp. 226-228. "On the Embryos of Bats," Contrib. Zool. Lab. Pennsylvania, i. Art. 2, pls. v.-viii. "On a Revision of the Ethmoid Bone in the Mammalia, with special reference to the description of this bone and of the sense of smell in the Chiroptera," Bull. Mus. Comp. Zool. Harvard, x. p. 135, and an earlier paper, *loc. cit.* No. 5, pp. 121-122. "On the Tarsus of Bats," Am. Nat. xx. pp. 175-177. "Genus *Nyctinomus*," P. Am. Phil. Soc. xxvi. pp. 558-563. "Muscles of the Hind Limbs of *Cheiromeles torquatus*," Science, vii. p. 506.

² MACALISTER, A.—"The Myology of the Chiroptera," Phil. Trans. Roy. Soc. 1872, pp. 125-171, pls. 13-16.

³ MAISONNEUVE.—Thèses présentées à la Faculté des Sciences de Poitiers. Paris, 1878, 8vo, pp. 324.

⁴ ROBIN, H. A.—"Recherches anatomiques sur les Mammifères de l'Ordre des Chiroptères," Ann. Sci. Nat. (6) xii. 1881, Art. 2, pp. 111-180, pls. ii.-ix., & Rev. Sci. xxix. p. 507. See also "Sur la Morphologie les enveloppes fœtales des Chiroptères," Compt. Rend. xcii. pp. 1354-1357, and "Sur les envel. fœt. des Chiroptères d. l. famille des Phyllostomides," *loc. cit.* xcv. p. 1377, and "Sur les envel. fœt. . . . des Molossiens," supplementary to the second paper, Bull. Soc. Philomathique, Paris, (7) v. pp. 142-143. "Sur l'époque de l'accouplement des Chauves-souris," *loc. cit.* (7) v. pp. 88-90. "Anatomy of *Cynonycteris amplexicaudata*," C. R. xc. pp. 1369-1370.

⁵ BENEDEN, E. VAN, and JULIN, C.—"Recherches sur la formation des annexes fœtales chez les Mammifères (Lapin et Chéiroptères)," Arch. Biol. v. p. 369, pls. Also "Observations sur le maturation, la fécondation, et la segmentation de l'œuf chez les Chéiroptères," Arch. Biol. i. pp. 551-571, pls. xxii. & xxiii., and Bull. Acad. Roy. Belgique, xlix. pp. 628-655.—E. VAN BENEDEN. "De la Fixation du Blastocyste à la Muqueuse utérine chez le Murin (*Vespertilio murinus*)," *loc. cit.* (3) xv. pp. 17-27. "De la formation et de la constitution du Placenta chez le Murin," *loc. cit.* pp. 351-364.

⁶ RÖSE, C.—"Beiträge zur vergl." etc., Morph. Jahrb. 1890, xvi. pp. 27-96, pls. iv. & v.

⁷ HYRTL.—Denksch. Akad. der Wiss. Wien, 1864, xxii. p. 132 *et seq.*, and a note on the Radial Artery, transl. by E. P. Wright, in Nat. Hist. Rev. vol. ii. 1862, p. 95 *et seq.*

the arteries in several species, the vascular system has received but scant notice.

The recent observations on the morphology of blood-vessels, especially those of Macalister¹, Mackay², Hochstetter³, and, Young⁴, have given an increased interest to studies of the vascular system; and it was in the hope of adding to the sum of our knowledge in this direction, even if only in a single order of the Mammalia, that this paper was commenced.

In the absence of any record of the general features of the Vascular System in the Chiroptera, the simplest plan appeared to be to describe as accurately as possible the arrangement in one species, taking it as a type to which variations might be referred, and this plan has been more or less adhered to in the following account. Illustrations have been added from other species where it appeared that the arrangement in *Pteropus medius* was unusual in the order, and some additional notes on the thoracic organs have been appended, when this seemed desirable for the sake of greater clearness in description.

The division of the Megachiroptera (Dobson) was selected on account of the greater size of its members, and *Pteropus medius*, the Indian Fruit-Bat, seemed a suitable representative⁵. This Bat is common in its native haunts—India—where it is found in large flocks, which often cause much loss by devouring enormous quantities of fruit, the voracity of these animals being apparently only limited by the amount of time and fruit at their disposal⁶.

¹ MACALISTER, A.—“The Morphology of the Arterial System in Man,” Journ. Anat. xx. 1886, pp.

² MACKAY, J. Y.—“The Development of the Branchial Arches in Birds, etc.” Phil. Trans. Roy. Soc. vol. 179 (1888), B. pp. 111-139, 4 pls. “The Arterial System of Vertebrates Homologically considered,” Proc. Phil. Soc. Glasgow, xviii. 1887, and in Mem. of Anatom. vol. i. 1889.

³ HOCHSTETTER, F.—“Ueber d. ursprüngl. Hauptschlagader d. hint. Gliedm. d. Menschen,” etc., Morph. Jahrb. xvi. 1890, pp. 300-318, and “Ueber d. Entw. d. Art. Vert. b. Kaninchen,” *loc. cit.* pp. 572-586, and “Ueber den Ursprung der Art. Subclav. der Vögel,” *loc. cit.* pp. 484-493.

⁴ YOUNG, A. H.—“The Termination of the Mammalian Aorta.” Studies in Anatomy. The Owens Coll. 1891, pp. 209-225, 1 pl., & Journ. Anat. xxxi. pp. 169-175.

⁵ The dissection of the smaller vessels in *Pteropus medius* proved difficult and tedious, although the body of this species is 8½ inches long and the expanded wings measure 3 feet across. The injection I found most suitable is the Lead Chromate and Gelatine recommended by Hoyer (Arch. f. mikr. Anat. 1876, p. 645), and quoted by Bolles Lee (Microtomist's Vade Mecum, p. 237), or Hoyer's Shellac injection, coloured with very finely divided vermilion (*loc. cit.* 1865, p. 149). I have found Von Graefe's cataract knife, modified by being strengthened a little along the back and shortened in the blade, very convenient. Some form of dissecting microscope is essential.

⁶ MURRAY, J. A., Indian Annals, i. pp. 25-26, gives a description of this species, and an account of the use of the flesh as medicine by the natives. See also SIGEL, W. L., Zool. Gart. xxiv. (habits of *P. medius* in captivity); and DAY, F., Land of the Permauls, p. 439, who states that these Bats are very partial to wild figs and almond-kernels, and also to cocoa-nut toddy.

BEAUREGARD, H.—“Recherches sur l'oreille interne de la Rousette de l'Inde (*P. medius*),” C. R. Ac. Sci. cxix. pp. 1351-1352. “Le Canal Carotid de Rousettes,” C. R. Biol. Paris, 1892, pp. 914-916. “Recherches sur l'appareil

The average measurements of this species are given in Dobson's Catalogue. Two of my specimens measured:—Specimen A. *Adult male*. Length, *circa* 210 mm.; interfemoral membrane 10; head 72; ear 38; eye to tip of nostril 29; forearm 147; thumb 64.5; 3rd finger 183; tibia 65; foot 51.

Specimen B. *Adult male*. Length, *circa* 225 mm.; interfemoral membrane 15; head 72; ear 38; eye to tip of nostril 29; forearm 155; thumb 65.5; 3rd finger 292; 5th finger 205; tibia 71; foot 49. Weight, 10½ oz. (spirit-specimen).

Thoracic Viscera.

The thorax in the Chiroptera is very much wider and more capacious than is usual in the Mammalia. *Pteropus medius* departs somewhat from the type, the thorax becoming longer and narrower, but still remaining very large. The thoracic viscera are correspondingly formed. The heart in this species is rather larger, and the lungs smaller, than is usual in the Order.

The Pleura.

Composed, as is usual, of a parietal portion, lining the thoracic cavity, and a visceral, clothing the surface of the lungs. But a certain degree of complexity is associated with the reflexion of this membrane from the upper aspect of the sternum, owing to the shape and disposition of the lungs and the relation to it of the so-called thymus gland.

Both parietal pleuræ pass upward together from the dorsal aspect of the sternum. Tracing first the pleura of the left side, anteriorly it passes upwards and to the left, and continued on the wall of the thorax is reflected on the anterior¹ surface of the pulmonary root, as in man. But owing to the projection across the mesial plane of the upper lobe of the left lung, the left pleural sac is carried to the right for a corresponding distance. On the ventral aspect is situated a portion of the thymus gland; a small tongue of the same gland extends forwards on its dorsal surface.

Posteriorly, the pleura passes to the left, lying ventral to the main part of the thymus and the pericardium, and then upwards, the line of reflexion from the diaphragm being 11 mm. to the left of the middle line. From this portion of the pleura the

auditif chez les Mammifères," Journ. de l'Anat. et Physiol. 1893, pp. 180-220, pls. iv.-vi.

HOME, SIR EVERARD.—Lectures on Comparative Anatomy. London, 1814, vol. i. pp. 158-160, vol. ii. pl. xx. (stomach of *Pteropus* and *Plecotus*).

CATTANEO, G.—"Sull' Anatomia dello Stomaco del *Pteropus medius*," Atti Soc. Ligustica, i. pp. 142-149.—WUNDERLICH, L., "Die Fortpflanzung der Flughunde (*Cynonycteris collaris*, Ill., and *P. medius*, Temm.) im Zool. Gart. zu Köln," Zool. Gart. xxxii. pp. 78-82.

¹ These terms suppose the animal to be placed with the ventral surface downwards, "above" being therefore synonymous with "dorsal to"; "anterior" and "in front of" corresponding to "on the cephalic side of."

ligamentum latum pulmonis proceeds outwards to the posterior lobe of the left lung, very much as in man.

The pleura of the right side extends upward from the sternum until it reaches the pericardium. Anteriorly it is folded around this, and reaching the root of the right lung becomes continuous with the visceral layer. Posteriorly, this reflexion of pleura passes upwards until it reaches the postcaval vein, which has an intra-thoracic course of some length—7 mm. in this species. Turning round the vein the pleura retraces its course, forming thus a median recess or pouch, in the posterior part of which lies the azygos lobe of the right lung, the anterior part being reduced to a mere chink by the near approach of the pericardium towards the diaphragm¹. The pleura finally leaves the anterior thoracic wall in company with the pleura of the left side, considerably to the left of the mesial plane. The *ligamentum latum pulmonis* passes to the posterior lobe of the right lung from the reflexion of pleura thus formed, lying dorsal to the azygos lobe.

The Lungs.

Following the nomenclature of Aeby², four lobes may be distinguished in the right lung—anterior, middle, posterior, and azygos; and two in the left—anterior and posterior. This agrees with the description of Robin³, whose careful and accurate work leaves little to be added by subsequent investigators.

The right lung is considerably larger than the left, and the main lobes of each are much subdivided by secondary fissures. The morphology of these, as well as an account of the pulmonary arterial and venous system, will be found in Part II. of this paper.

The relation of the lungs to the ventral wall of the thorax would appear to vary somewhat. Robin³ describes the posterior lobe of the left lung as extending across to meet the middle lobe of the right lung, lying beneath the base of the heart and great vessels. In my specimens, shrunk a little by immersion in spirit, this was not the case (fig. 1), and in transverse sections of *Vesperugo noctula* and *Rhinolophus hipposideros*, with the organs carefully hardened *in situ*, there was still a considerable interval.

The anterior lobe of the left lung crosses the mesial plane ventral

¹ I was interested in observing in a dissection of a Dromedary an intermediate stage between the condition found in *Pteropus* and in man. In that animal, anteriorly the pleuræ of both sides pass upward in the middle line from the sternum, forming a definite mesial partition. Posteriorly, the arrangement is exactly similar to that described above, except that the median recess is much reduced in size, owing to the smaller development of the azygos lobe. The pleura is strong and tough, and can be followed out with the greatest ease. In man, the azygos lobe has altogether disappeared in the adult, and the pleural recess is reduced to a minimum ("*mediastino-diaphragmatic sinus*," Macalister, Human Anatomy: London, 1889, p. 316).

² AEBY.—Der Bronchialbaum der Säugethiere, etc. Leipzig, 1880.

³ ROBIN, H. A.—"Recherches etc." *v. supra*. See also on this subject, DAUBENTON (Buffon and Daubenton, Hist. Nat. x. p. 70, 1763). OWEN (Comp. Anat. of Vertebr. iii. p. 577), and CUVIER (Anat. Comp. 2nd ed. vii. p. 151).

to the pericardium, and the azygos lobe of the right lung crosses similarly on the dorsal side, lying immediately behind the left auricle and ventricle.

Fig. 1.

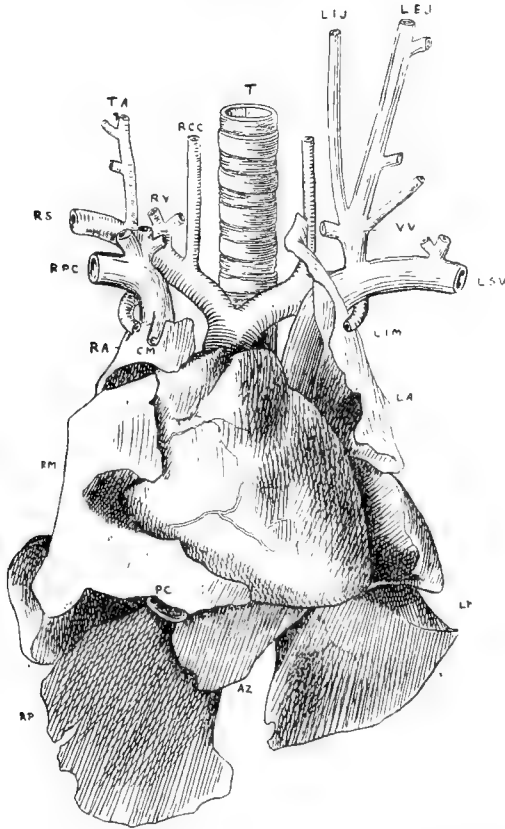

Heart and lungs of *Pteropus medius*, seen from the ventral aspect. $\times 1\frac{1}{2}$. The blood-vessels are slightly diagrammatic; the exact position is seen in fig. 4 (p. 66), which is from a photograph. The anterior lobe of the left lung is raised slightly to show the conus arteriosus.

R.S. Right Subclavian artery. T.A. Thyroid Axis. R.C.C. Right Common Carotid. R.V. Vertebral. L.I.M. Left Internal Mammary. R.P.C. Right Precaval Vein. L.S.V. Left Subclavian Vein. L.I.J. Left Internal Jugular. L.E.J. Left External Jugular. V.V. Left Vertebral. P.C. is placed on the middle lobe of the right lung just above the Post-caval Vein. T. Trachea. R.A., R.M., R.P. Anterior, middle, and posterior lobes of the right lung. A.Z. Azygos lobe. L.A., L.P. Anterior and posterior lobes of the left lung.

The Pericardium.

A very definite sac, composed of two layers—a fibro-serous, forming an envelope for the heart and great vessels, and a serous, reflected on to the surface of those structures.

The fibro-serous layer encloses a space, the shape of which is

approximately oval in outline. It is prolonged forward to become continuous with the outer coats of both precaval veins and the aorta, and encloses within it the whole length of the pulmonary artery. Behind, it is pierced close to the auricle by the postcaval vein, so that this vessel has only a course 3 mm. in length within the pericardium, in spite of the length of the intra-thoracic portion of that vessel. Posteriorly, this layer is in contact with the diaphragm, but the connexion between them is of the slightest, the most definite attachments being by means of the reflexion of the pleura from the diaphragm on each side.

Fig. 2.

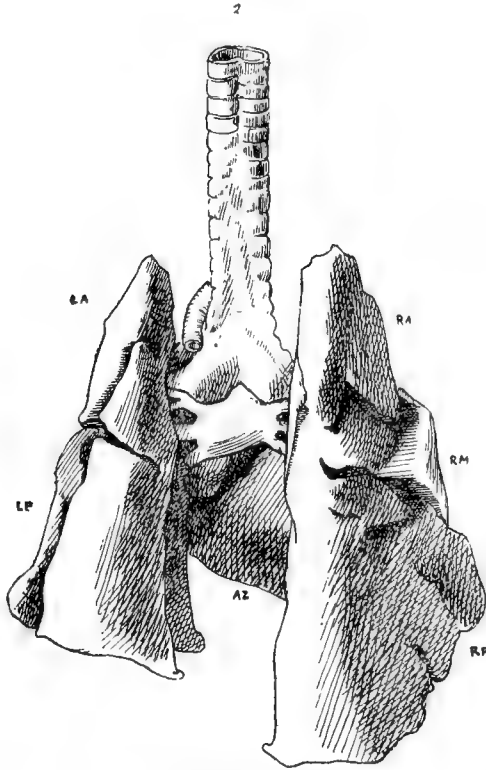
Heart and lungs of *Pteropus medius*, dorsal aspect. $\times 1\frac{1}{2}$.

Letters as in fig. 1.

Intimately connected with the fibro-serous layer of the pericardium is the so-called thymus gland, especially on the ventral surface. Elsewhere this layer is thin and delicate, resembling the human peritoneum in appearance, but firmer and less elastic than that structure.

The serous layer clothes the surface of the heart; it is reflected from the outer layer where the postcaval vein enters, as well as at the entrance of the other vessels.

*Thymus*¹.

The general collection of tissue that has in the aggregate been called the thymus gland is developed to an unusual extent in the Chiroptera. In this species it is composed of gland-like masses irregular in outline, showing a tendency to separate into smaller lobules. This tissue is scattered about the middle mediastinum, one mass being placed at the base of the heart, another ventral to the pericardium where it meets the diaphragm, another within the pericardial sac, at the base of the great vessels. The relation of the gland to the pleura is very intimate.

The Heart.

Of large size even for the Chiroptera, measuring $26 \times 15 \times 15$ mm. The general shape is that of an elongated oval, placed very obliquely

Fig. 3.

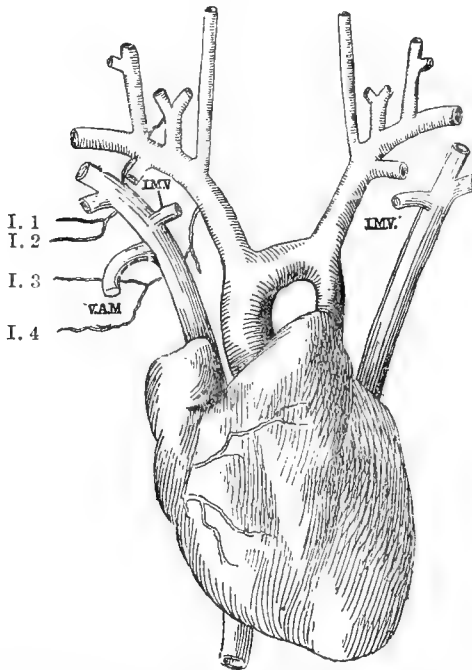

Heart of *Pteropus edulis*, ventral surface, $\times 1\frac{1}{2}$.—I. 1-4. Intercostal arteries in the upper four spaces of the right side, 1 and 2 arising from the Vertebral, 3 and 4 from the Innominate. I.M.V. Internal Mammary Veins, joining the Right and Left Precaval veins. V.A.M. Vena azygos major.

¹ The description applies to the naked-eye appearance of this structure. Microscopic sections (specimen A) show numerous much vacuolated cells, with no definite arrangement, intimately related to blood-capillaries, and with no ducts. Sections of the same gland in specimens C and D show only adipose tissue. Further investigation is necessary to reconcile the appearances observed.

in the thorax, the apex extending posteriorly and to the left. Clothing the surface is the serous layer of the pericardium; and it is noticeable that the deposit of fat, so often observed in man, is entirely absent here. In the groove between the right auricle and the aorta is a small portion of the so-called thymus gland.

Fully three-fourths of the ventral surface is formed by the ventricles, little more of the right auricle than the appendix being seen from this aspect, and but the extreme tip of the appendix of the left auricle, appearing under cover of the right precaval vein. Of the ventricular part, three-fifths are formed by the right ventricle, the remainder, including the apex, by the left. (Fig. 1, p. 63.)

On the dorsal surface of the heart the ventricles occupy scarcely one half, the auricles, with the much expanded transverse part of the left precaval vein, forming the remainder. (Fig. 4.)

The *Right Auricle* is composed of appendix and atrium, separated externally by a well-marked sulcus. In the specimens I have examined it was much distended with clotted blood, so that it appeared considerably more capacious than the left auricle. More of the right auricle also appears on the surface than the left, the latter being concealed by the left precaval vein and the pulmonary artery with its branches.

Fig. 4.

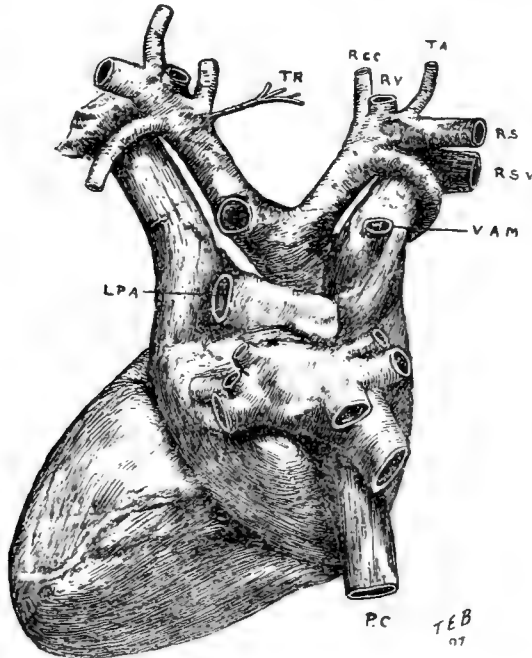

Heart of *Pteropus medius*, dorsal surface, $\times 2$.—TR. Pretracheal branch from base of left common carotid artery. L.P.A. Left Pulmonary Artery. Other letters as in fig. 1.

The wall of the right auricle is thin, and on opening the cavity

is seen to be sculptured in low relief over the greater part of its extent with a series of muscular bands running parallel to each other at a little distance apart, joined with cross bands and terminating on a well-marked crista terminalis. These musculi pectinati are stouter and better marked in the appendix than elsewhere. There was no representative of the "tubercle of Lower."

Three main venous trunks open into the atrium. The aperture of the right precaval vein is the most anterior; at some little distance behind is the opening of the postcaval, guarded by the Eustachian valve, here a thin fenestrated membrane, continued on to the isthmus Vieussenii as in man. (Fig. 6, p. 68.) Just above the auriculo-ventricular opening is the entrance of the left precaval vein, separated from the postcaval by a well-marked muscular shelf, the valve of Thebesius being entirely absent, as Röse¹ also found. Two or three ventral cardiac veins run forward over the right ventricle to open directly into the auricle, and two or three dorsal veins, one larger than the rest, open into the transverse part of the left precaval.

The *Right Ventricle* is folded around the left ventricle, and the interventricular septum encroaches on its cavity, so that the outline in transverse section is crescentic.

The conus arteriosus is markedly prolonged, forming a very characteristic feature in the Chiropteran heart, and even more conspicuous in *Pteropus edulis* (fig. 3, p. 65) than in this species.

The inner surface of the ventricular wall is quite smooth and uniform except where it meets the septum, where a few very small irregularities remain. No musculi papillares arise from the ventricular wall; a very slender moderator band alone takes origin here and passes to the septum.

The auriculo-ventricular valve has developed on a somewhat different plan from most other Mammalia, resembling the condition figured by Ray Lankester² in the Rabbit. It is composed of two separate segments, the outermost and ventral of these being considerably the larger, representing the infundibular and marginal parts of the usual tricuspid valve. Arising from the interventricular septum to supply this segment are four musculi papillares, each sending 3-4 chordæ tendineæ to be inserted into the free edge of the valve, the adjacent chordæ being continued upward on the outer surface to form an arch³, as shown in fig. 5, p. 68.

The innermost segment is closely applied to the septum. Many

¹ RÖSE, C., *loc. cit.*

² P. Z. S. 1882, pp. 535-544, pl. xxxviii. figs. 3 and 4. He considers the auriculo-ventricular valve in this animal to be a further development from the original condition preserved in man and most mammals. If this view be adopted, the valve in *Pteropus* might be considered to occupy an intermediate condition. On the origin of the musculi papillares from the septum, see RÖSE (*loc. cit.* pp. 84-85), who remarks that it is a point of no morphological importance.

³ KÜRSCNER (Wagner's Handwörterbuch, p. 47) describes a similar arrangement of chordæ tendineæ in the human heart as an uncommon abnormality. Class 1 of his division is unrepresented in the heart of *Pteropus*.

Fig. 5.



Heart of *Pteropus edulis*, $\times 2$.—A portion of the wall of the right ventricle has been turned back to show the auriculo-ventricular valve, the two segments of which are seen. M. Moderator band.

Fig. 6.

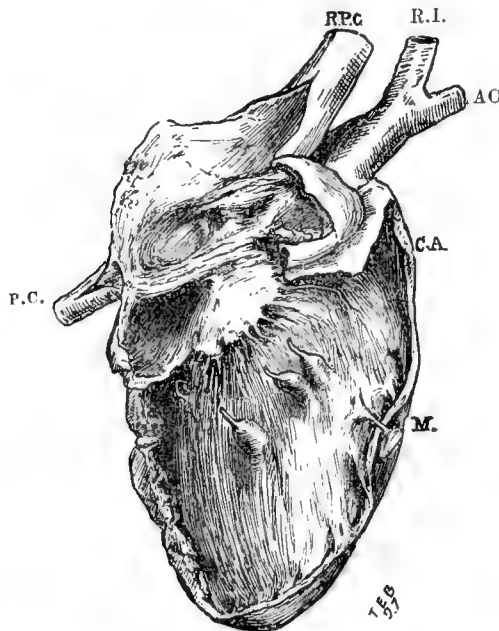

Heart of *Pteropus edulis*, $\times 2$.—The right auricle has been opened by the usual incisions, and the whole of the wall of the right ventricle removed with the outer segment of the auriculo-ventricular valve; the septal segment is seen in its whole extent. AO. Aorta. R.L. Right Innominate Artery. R.P.C. Right Precaval Vein. P.C. Postcaval Vein; below this is seen the opening of the Left Precaval. C.A. Conus arteriosus. The attachments of the musculi papillares and moderator band to the septum are shown.

slender chordæ tendineæ are attached to its free edge; they all arise directly from the septum, without the intervention of muscoli papillares, and they are quite separate from the set belonging to the outer segment, each set supplying its own part of the valve only (fig. 6, p. 68).

The pulmonary orifice is guarded by a valve of three semilunar flaps, two placed ventrally and one dorsally, as in man.

The atrium of the *Left Auricle* appears on the dorsal surface of the heart between the systemic veins entering the right auricle and the pulmonary artery. (Fig. 4, p. 66.) The tip of the appendix appears on the ventral surface, the base being concealed in front by the right pulmonary artery and on the left by the left precaval vein. On opening the cavity, the walls are seen to be thicker than those of the right auricle, and smooth internally, a few feeble muscoli pectinati being found only in the appendix, which is longer and narrower than on the right side and much less capacious. On the interauricular septum a faint depression indicates the position of the foramen ovale; here the wall is very thin, but no communication exists between the auricles.

The left pulmonary veins open by one common orifice into the dorsal surface of the atrium, the right by three separate openings.

The *Left Ventricle* contrasts markedly with the corresponding cavity on the right side, being constructed on a much stronger and more muscular plan. The outline in transverse section is circular. Two large and strong papillary muscles, extending down to the apex, and attached along their whole length to the outer portion of the ventricular wall, send chordæ tendineæ to the two segments of the mitral valve, each papillary muscle supplying part of both segments. Fine columnæ carneæ, consisting of low closely-set ridges, cover the interventricular septum and the wall of the ventricle between the muscular attachments.

The auriculo-ventricular aperture is oval in shape, and considerably smaller than on the right side. The mitral valve consists of two segments—the lesser is placed against the outer wall of the ventricle, the greater hangs between the aortic and auriculo-ventricular orifices. The aortic valve consists of three segments, one ventral and two dorsal, and the coronary arteries arise from the ventral and left dorsal sinuses of Valsalva. The structure of both this and the pulmonary valve closely resembles the arrangement in man.

The weight¹ of the heart in *P. medius* is about 26 grains, approximately $\frac{1}{178}$ of the body weight, compared with $\frac{1}{205}$ in man. The thickness of the wall of the right ventricle at its base is 1 mm., of the corresponding part of the left ventricular wall 4 mm. This ratio is even greater in the smaller Bats, in *Vesperugo noctula*, for instance, the figures are .5 mm. and 2.4 mm.

The Aorta and its Branches.

Arising from the left ventricle, the ascending aorta is at first concealed from view in the undissected heart. The right auricular

¹ Taken from spirit-specimens.

appendix and the infundibulum of the right ventricle cover it on the ventral aspect. The right auricle and the right precaval vein conceal it on one side, the pulmonary artery on the other, and on the dorsal surface the right pulmonary artery crosses above it. A comparatively short distance remains therefore between the surface of the heart and the origin of the right innominate artery (fig. 1). This vessel arises at a distance¹ of 8.5 mm. from the ventricle, and from this point the aorta, reduced in diameter from 4 mm. to 3 mm., crosses the thorax, curving round the trachea. The left innominate artery takes origin 6 mm. from the right innominate, and from this point the course of the aorta is upward and backward, receiving the obliterated ductus arteriosus 4.5 mm. from the left innominate, and passing above the root of the left lung.

The left vagus nerve crosses between the left innominate and left precaval vein, the recurrent laryngeal branch turning round the ductus arteriosus. The trunk of the nerve passes on to form anterior and posterior pulmonary plexuses in the usual manner.

The descending thoracic aorta has much the same relation to surrounding structures as in man, lying on the bodies of the vertebræ between the pleural sacs, and having the thoracic duct and vena azygos major to the right, while the œsophagus lies on its ventral surface. The length from the ductus arteriosus to the opening in the diaphragm is 35 mm.

The descending thoracic aorta gives off the usual œsophageal and mediastinal branches, and intercostal arteries to all the spaces below the second. The first space is supplied by a branch from the vertebral, the second space either from the vertebral or, more commonly, from the aorta. The anterior intercostal arteries on the right side pass outwards dorsal to the thoracic duct and vena azygos major, below the eighth space they cross on the ventral side. The relations of the sympathetic cord and subcostal muscle are similar to man.

In one specimen of *Pteropus edulis* the upper two spaces on the right side were supplied by the vertebral, the third and fourth by a branch from the innominate (fig. 3, p. 65), the remainder from the aorta. The bronchial arteries in this species arose by a single trunk from the aorta.

Right Innominate Artery.—With the exceptions to be presently noted, the right and left innominate arteries correspond closely with regard to their course, distribution, and branches. Springing from the right extremity of the aortic arch the artery of the right side, 2 mm. in diameter, passes forward and outward, and above (dorsal to) the sterno-clavicular articulation, at a distance of 6 mm. from its origin, divides into the right common carotid and subclavian, the former, much the smaller, appearing like a branch of the main trunk.

Small mediastinal branches arise from both innominate arteries to supply adjacent structures.

¹ The measurements of arteries and veins are all taken to the mid-point of the origin of the branch referred to, except when otherwise indicated.

The *Common Carotid Artery* on either side runs directly forward, the only thoracic branch being a small offset to the front of the trachea, springing from the artery of the left side close to its origin from the innominate.

The first branch of the *Right Subclavian Artery*, which here appears like the continuation of the innominate, is the internal mammary, arising from the outer side of the vessel scarcely 1 mm. from the origin of the common carotid. 15 mm. beyond this, from the opposite side of the subclavian, is the origin of the vertebral. This vessel, nearly equal in size to the remainder of the parent trunk, has a short course directly forwards, and then divides into two branches, one running outwards, the other, the vertebral proper, entering the vertebralarterial canal of the sixth cervical vertebra.

Fig. 7.

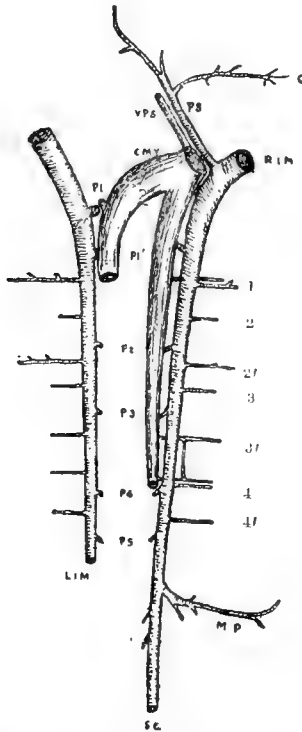

The Internal Mammary Arteries and Veins from the dorsal aspect, $\times 1\frac{1}{2}$.— R.I.M. & L.I.M. Right and Left Internal Mammary Arteries. P.S. Presternal Artery. C. Clavicular branch. 1. Ventral Intercostal Artery in first intercostal space; 2, 2', in second space; between 1 and 2 lies the second rib, similarly for the rest of the series. 3' is absent on the right side. M.P. Musculo-Phrenic Artery. S.E. Superior Epigastric Artery. P 1—P 5. Ventral perforating arteries in the several outer costal spaces. C.M.V. Common Mammary Vein, formed by union of the veins of both sides. V.P.S. Presternal Vein. A communicating band joins the ventral intercostal veins of the third and fourth spaces on the right side. Except where drawn, the veins are exactly similar to the arteries in their distribution, one vein accompanying each artery.

1 mm. from the origin of the vertebral the thyroid axis, a slender vessel running forward, is given off, and from this the subclavian pursues a course almost directly outward, and arching across the first rib is continued into the axillary.

The two *Internal Mammary* arteries (figs. 1 and 7) differ somewhat on the two sides. The right internal mammary, rather larger than the left, arises from the subclavian, and turning round the right precaval vein runs at first obliquely inward and backward, between the pleura and the chest-wall, and embedded in the substance of the ventral part of the thymus gland. After a little the common mammary vein joins the artery, lying to its inner side. Reaching the junction of the presternum with the mesosternum, the artery passes backward, and finally divides opposite the sixth costal cartilage into the musculo-phrenic and superior epigastric arteries, the latter considerably the larger and continuing the direction of the parent trunk.

The branches of the internal mammary artery are:—

1. A branch arising 11 mm. from the subclavian, which runs forward and inward (fig. 7) to the suprasternal notch, where it divides into several branches to supply the upper part of the thymus, the trachea, the infrahyoid muscles, and the anterior part of the pleura, and sends one slender twig outward along the anterior border of the clavicle. This branch I have called *presternal*.

2. Ventral perforating arteries, which supply the pectoralis major and adjacent muscles. In the first intercostal space one perforating artery appears at the upper part of the space and one at the lower; all the subsequent spaces have only one each, appearing at the lower border of the space. In this species all these arteries do not differ much in size, but in many of the *Microchiroptera* (*V. noctula* e. g.) the first and fourth (third space) are much larger than the rest.

3. Ventral intercostal branches. Two in each space except the 1st; arising separately from the internal mammary, and with a course as in man along the margins of the ribs. The branch at the posterior edge of each space is a very minute vessel.

I could not discern any branch corresponding to the *arteria comes nervi phrenici* of human anatomy.

The Left Internal Mammary Artery has a similar origin to the right. It turns round the left precaval vein, and passes to a similar position by the side of the mesosternum, giving off no branches until it reaches this point. Here it first meets with the left internal mammary vein, which lies internal to it, and for the rest of its course resembles exactly the artery of the right side.

Thoracic Veins.

Right Precaval.—In the lower part of the neck three venous trunks join—the vertebral, the internal jugular, and the external jugular, the two former nearly equal in size, the latter as large as both taken together (fig. 1). After a course of 2.5 mm. the common trunk thus formed joins with the subclavian, at a point immediately above the sterno-clavicular articulation, and

is continued onward as the precaval. Immediately dorsal to the vessel there is the right subclavian artery.

The precaval vein then runs inward and backward to join the anterior part of the right auricle. On its right side are placed the corresponding internal mammary artery, the upper lobe of the right lung, and the right phrenic nerve. To the left lie the right innominate artery, the ascending aorta, and posteriorly the left vagus nerve. On the ventral surface the precaval, below the entrance of the common mammary vein, is covered by the upper lobe of the right lung. Its total length is 10 mm.

The tributaries of the right precaval are:—

1. The vena azygos major, joining the dorsal surface of the vessel 4 mm. from the surface of the auricle.
2. The common mammary vein, joining the ventral surface.
3. Small mediastinal and thymic veins enter at various places.

The course of the *Vena Azygos Major* is forward, lying on the left side of the centra of the vertebræ, till it reaches the fourth intervertebral disc. Here it turns downward and ends by joining the right precaval, as already described. The intercostal veins of both sides join the vena azygos major (those of the left side passing above the aorta), except in the first intercostal space on the right side, and the first and second on the left, the veins from these spaces passing to the vertebral.

Common Mammary Vein.—The right and left internal mammary veins arise by tributaries which correspond closely to the arteries, one vena comes accompanying each branch. Both veins run forward, lying immediately behind the junction of the ribs with the mesosternum, immediately internal to the artery (fig. 7). At the middle of the first intercostal space, having been joined by the highest perforating vein, the left internal mammary inclines to the right, crossing behind the presternum, and joins the vein of the right side to form the common mammary¹. This continues the direction of the left vein, and, receiving a tributary corresponding to the presternal artery, joins the right precaval, 6.5 mm. from the surface of the auricle.

In fig. 3 (p. 65), which represents the heart and great vessels of *Pteropus edulis*, the internal mammary veins are seen to join the corresponding presternal veins in the usual manner.

Left Precaval Vein.—Formed by the same tributaries and in the same manner as the corresponding trunk on the right side. The vessel lies at first between the subclavian artery above and the upper lobe of the left lung below, pursuing a slightly arched course backward and a little inward, till it reaches the auriculo-ventricular groove, 19 mm. from its origin. Here it turns to the right, and much increased in calibre ends in the right auricle, at a point corresponding to the opening of the coronary sinus in man.

The left precaval vein receives small mediastinal and thymic branches, and close to its termination the dorsal cardiac veins.

Postcaval Vein.—The thoracic portion of this vessel runs directly

¹ A very similar arrangement is to be met with in the *Capybara* (*Hydrochærus capybara*) and also in the Common Fox (*Canis vulpes*).

forward, receiving no tributaries, to the right auricle. The vein lies in a groove in the azygos lobe of the right lung, separating it from the posterior lobe; its relation to the pleura has been already noticed. This part of the vessel measures 7 mm. in length.

I have been obliged, owing to ill-health and other causes, to postpone the publication of the rest of this paper.

I have much pleasure in expressing my thanks to Professor Howes, for his kindness in providing me with material; to Mr. W. C. Hoyle, for great assistance in consulting the literature of the Order; and to Miss E. M. Gore, for some beautifully executed drawings.

LITERATURE.

The systematic and distributional literature of the Chiroptera is tolerably voluminous. It is unnecessary in this paper to do more than briefly refer to the labours of O. Thomas, F. A. Jentink, and others, published chiefly in the 'Annals and Magazine of Natural History,' 'Annali del Museo di Genova,' and 'Proceedings' of this Society. Up to 1878 many references are to be found in Dobson's Catalogue, and in more recent times in H. Allen's Monograph, and Flower and Lydekker's *Mammals* (Introduction to Study of Mammals etc., Lond. 1891. Chiroptera, pp. 641-679). Since 1864 a very complete list may be found in the Zoological Record for each year.

It also seems needless to quote the various works on Comparative Anatomy in general. A summary of these may be found in H. G. Bronn's 'Thier-Reich,' Säugeth. (W. Leche): Leipzig & Heidelberg, 1884, Band vi. Abth. v. pp. 10-13, 18-19, etc.

The following list comprises chiefly the anatomical and physiological literature not already mentioned, some of the more exclusively distributional papers that have been published since the appearance of Dobson's Catalogue being also inserted. The abbreviations are those used in the Zoological Record for 1895.

- AMANS, P. C.—"Comparaisons des organes du Vol dans la série animale." *Ann. Sci. Nat.* (6) xix. pp. 186-195.
- BALLOWITZ, E.—"Ueber die Vorkommen der *Minopterus schreibersii*, Natterer, in Deutschland, nebst einigen Bemerkungen über die Fortpflanzung deutscher Chiropteren." *Zool. Anz.* xiii. pp. 531-536.
- BATTEN, J. D.—*Nature Notes*, No. 72, vol. vi. Dec. 1895, pp. 224-229. (Remarks on food, habits, and psychology of English Bats.)
- BELL, T.—*History of British Quadrupeds*. Has figures of 12 British Bats, described by TOMES, R. F. 2nd ed., Lond. 1874.
- BIELZ, E. A.—"Ueber die in Siebenbürgen vorkommenden Fledermäuse." *Verh. Siebenb. Ver.* xxxvi. pp. 76-84. (17 Siebenbürgen Bats. Quotes DADAY, *Orvos-természethudo-mányi ertesítő*, x. p. 266. On new varieties and species.)

- BLAKE, H. A.—“Note on the Parturition of a West Indian Bat.”
P. R. Dubl. Soc. iv. pp. 449 & 450.
- BLANFORD, W. T.—The Fauna of British India, including Ceylon and Burma. Lond. & Calcutta, 8vo. Pt. I. Mammalia. See also Jour. Asiat. Soc. Bengal, vol. lvii. pp. 260, 272; & P. Z. S. 1887, pp. 620–630. (*Hipposideros* and *Phyllorhina*, nomenclature.)
- BROOM, R.—“On the Organ of Jacobson in an Australian Bat (*Minopterus*).” Proc. Linn. Soc. N.S.W. ser. ii. vol. x. pp. 571–575, pl. xlv.
- VAN BENEDEN, P. J.—“Les Parasites des Chauves-souris de Belgique.” Mém. Ac. Belg. xl. pp. 42, 7 pls. (with observations on the hosts).
- CHEESEMAN.—“Notes on the New Zealand Bats.” Tr. N. Zealand Inst. xxvi. pp. 218–222. (Zool. Rec. xxxi. 1894.)
- COPE, E. D.—Am. Nat. xiv. p. 745. (*Vesperugo anemophilus*, Wasatch beds of Wyoming.) See also Bull. U.S. Geol. Surv. vi. p. 184.
- CRETZ, C.—“Contribution à la connaissance de l'ovaire des Chiroptères.” Rech. Lab. Anat. Univ. Rom. iii. Art. 3, 1893. Summary in Arch. Ital. Biol. xxii. p. 148.
- DALLAS, W. S.—Short Studies from Nature. Lond. 8vo (Popular), and in ‘Cassell’s Natural History,’ vol. i. Lond., 1877.
- DELSAUX, E.—“Sur la respiration les Chauves-souris pendant leur Sommeil hibernale.” Arch. Biol. vii. pp. 205–211.
- DEPÉRET.—Arch. Mus. Lyon, v. pp. 11–16, pl. ii. (*Rhinolophus lugdunensis* et *collongensis*; *Vespertilio grivensis*. Miocene, Mt. Ceindre, Grive St. Alban.)
- DUVAL, M.—“Études sur l’embryologie des Chiroptères.” J. Anat. Physiol. xxxi. pp. 94–160, 427 & 474, pls. iii., xi. & xii.
- DUVAL, M.—“Sur l’accouplement des Chauves-souris.” C. R. Soc. Biol. (10) ii. pp. 135–136.
- DUVAL, M., & GARNAULT, P.—“L’organe de Jacobson des Chiroptères.” T. c. pp. 478–481.
- EIMER, TH.—“Ueber die Fortpflanzung der Fledermäuse.” Zool. Anz. ii. pp. 425–426.
- ESPADA, JIMENEZ DE LA.—Algunos etc. de la Fauna d. a. Amazonas. Madrid, 1870. (Sucking-cups of *Thyroptera*.)
- FLOWER, W. H.—“Liver of *Desmodontes*.” Medical Times & Gazette, 1872, ii. p. 60.
- FRIES, S.—“Ueber d. Fortpflanzung der einheimischer Chiropteren.” Nachr. Ges. Gött. 1879, pp. 295–298; Zool. Anz. ii. pp. 355–357.
- FROMMEL, R.—Ueber die Entwicklung der Placenta von *Myotis murinus*. Wiesbaden, 8vo, 1888, and in S.B. Ges. Morph. iv. pp. 114–115.
- GIEBEL, C. G.—Z. ges. Naturw. li. p. 329. (Pelvis of *Noctilio leporinus*.)
- GODMAN, F. D., & SALVIN, O.—Biologia Centrali-Americana, or Contributions to a Knowledge of the Flora and Fauna of

- Mexico and Central America. Zoology, pts. i. & ii. Lond., 1879. Chiroptera by E. A. ALSTON. Chiefly systematic. Figures.
- GOELDI, E. A.—Zool. Gart. xxviii. pp. 163–162. (Food of Vampires.)
- GRAY, J. E.—Catalogue of Monkeys, Lemurs, and Fruit-eating Bats in the Collection of the British Museum. Lond., 1870.
- HARTING, J. E.—Zool. (3) xii. pp. 161–166 & 441, pls. ii. & iii. (*Vespertilio mystacinus*, notes and figures).—Do., Ann. Mus. Genov. iv. pp. 625–630 (*Vesperugo noctula*, notes and figures).—Do., Field, 1889. (Piscivorous habits of *Noctilio leporinus*, with figs. of head, skull, & foot; cf. H. CARACCILO, Le Nat. 1889, p. 181, & TROUËSSART, l. c. p. 186.)—Do., Zool. (3) xv. pp. 201–205, pl. i. (*V. serotinus*).—Do., Zool. (3) xi. pp. 161–172. British species, l. c. HAIGH, HELSALL, LILFORD, & MACPHERSON.—Do., Arch. Néerl. iv. (wings and wing-muscles of flying vertebrates).
- HENSEL.—Zool. Gart. 1869, pp. 135–140. (Habits of Bats. esp. *Desmodus* and *Diphylla*.)
- HERRERA, D. A. L.—“Queiropterons de Mexico.” Nat. Mex. (2) i. pp. 218–226. See also *loc. cit.* pp. 298–299.
- HERZFELD, P.—“Ueber das Jacobson'sche Organ des Menschen und der Säugethiere.” Zool. Jahrb. 1888, p. 551 *et seq.* pls. (*P. edwardsi*).
- HOFFMANN, B.—“Ueber Säugethiere aus dem Ostindischen Archipel.” (Mäuse, Fledermäuse, Büffel.) Abh. Zool. Mus. Dresden, No. 3, pp. 30 & pl.
- HOFMANN, A.—Abh. geol. Reichsanst. xv. pt. 4, p. 18. (*Rhinolophus schlosseri*, Miocene, Syria.)
- HUMPHRY, G. M.—“The Myology of the Limbs of *Pteropus*.” Journ. Anat. & Physiol. iv. 1869, pp. 294–319, with 2 plates. (Dissection of ♂ & ♀ *P. edwardsi*.)
- HUXLEY, T. H.—P. Z. S. 1865, pp. 386–390, woodcut. (Stomach of *Desmodus rufus*.)
- JAMESON, H.—“Irish Bats.” Irish Naturalist, iii. pp. 69–71, & vi. No. 2, Feb. 1897. See on this subject also BARRINGTON, R. M., various papers in ‘Zoologist.’
- JENTINK, F. A.—Catalogue ostéologique des Mammifères du Mus. Hist. Nat. des Pays-Bas. Leyden, 1887. (A catalogue of skeletons and skulls, including 128 skeletons and 637 skulls of Chiroptera.)
- JENTINK, F. A.—Tijdschr. Nederl. Dierk. Ver. iv. pp. 58–61 (Netherlands Chiroptera).—Notes Leyden Mus. xiii. pp. 202–206 (*Cynopterus brachyotis*, Müll., and *Kerivoula pellucida*, Waterh.).—L. c. ix. pp. 171–180 (Ch. of Mossamedes).—L. c. vii. pp. 33–38, pls. i. & ii. (Ch. & Mammals from Niam-Niam, Africa). In Weber's Zool. Ergb., Leyd. 1890 (Ch. of Dutch E. Indies).
- JONES, TH. WHARTON.—Phil. Trans. 1852, P. R. S. 1868. (Contractile veins in wing of Bat.)

- DE KERVILLE.—Le Nat. 1891, p. 239. (Description and photo of a colony of *Rhinolophus ferrum-equinum*.)
- KOLENATI.—Beitr. z. Naturgesch. der Europ. Chiropt. Dresden, 1857.
- KRARUP-HANSEN, C. J. L.—Beitr. z. e. Theorie d. Fluges d. Vögel, Insekten und Fledermäuse. Copenhagen, 1869, 8vo, 42 pp.
- LATASTE, F.—“Études sur la Faune Chilienne—Note sur les Chauves-souris.” Actes de la Soc. Sci. d. Chili, i. pp. 70-91.
- LECHE, W.—“Zur Kenntniss des Milchgebisses und der Zahnhomologien bei Chiropteren. ii. Theil.” Act. Lund. xiv. p. 37, 2 pls. See also Am. Nat. xii. p. 910, and Lunds Univ. Års-skr. xii. (1875). Translated in Arch. f. Nat. 1877, pp. 353-364.
- LECHE, W.—“Ueber die Säugethiergeattung *Paleopithecus*.” Sv. Ak. Handl. vol. xxi. pt. xi. 1886. (Affinities of Chiroptera.)
- LECHE, W.—“Ueber die Entwicklung des Unterarms und Unterschenkels bei Chiropteren.” Sv. Ak. Handl., Bihang v. No. 15.
- LUCAS, T. P.—Proc. Roy. Soc. Queensland, vol. xii. 1897, pp. 49-53. (Habits of species of *Pteropus*.)
- LUCHSINGER, B.—“Von den Venenherzen in der Flughaut der Fledermäuse. (Ein Beitrag zur Lehre von dem peripheren Gefäßstonus.)” Arch. Ges. Phys. Bonn, xxvi. pp. 445-458.
- MACPHERSON, H. A.—“The habits of the greater Horse-shoe Bat.” Naturalist, 1886, pp. 337-339.
- MARCHI, P.—Atti Soc. Ital. xv. f. 2, pls. 8-11. (Morphology of hairs of Chiroptera.)
- MERRIAM, C. H.—“Do any of our North American Bats migrate? Evidence in the affirmative.” (*Atalapha cinerea* and *Vesperugo noctivagans*.) P. Am. Assoc. xxxv. p. 269.
- MILLER, G. S. “Revision of N. American Vespertilionidæ.” N. American Fauna No. 13. Washington, 1897. 135 pp., 3 pls., and illustrations in text. (Systematic and historical, with references to literature.)
- MONTICELLI, F. S.—“I Chiropteri del mezzogiorno d'Italia.” Atti Soc. Ital. xxviii. pp. 169-241, 1 tav. (Monograph of Italian Bats.) See also P. Z. S. 1886, pp. 93-96.
- MONTICELLI, F. S.—“Sulla Glandola facciale dei Chiropteri.” Revist. Ital. Sci. Nat. ii. pt. i., 1886.
- MONTICELLI, F. S.—“Note Chiropterologiche.” Ann. Mus. Genov. (2) v. pp. 517-524, woodcuts.
- MONTICELLI, F. S.—“Some remarks on the genus *Taphozous*.” Ann. N. H. (6) iii. pp. 487-489.
- NOACK, T.—Zool. Jahrb. ii. p. 268, pl. x. figs. 28-30 (skull and description of *Epomophorus minor*, and l. c. p. 282, pl. x. figs. 34 & 35, *Taphozous mauritianus*).
- OSBORN, H. F.—American Nat., Dec. 1888, p. 1072. (Nomenclature of tubercles of molar teeth.)
- OTTO.—“Mémoire sur les vaisseaux céphaliques de quelques animaux qui s'engourdissent pendant l'hiver.” Nova Acta

- Acad. Nat. Curios. 1826, and in Ann. des Sci. Nat. Zool. 1827.
- PETTIGREW, J. B.—Trans. R. Soc. Edin. 1871, xxvi. pp. 321–448, pls. 11–16. (Physiology of Wings of Insects, Bats, and Birds.)
- QUELCH, J. J.—“The Bats of British Guiana.” Timehri, ser. 2, vol. vi. 1893, pp. 90–109. (Habits of species etc.)
- REDTEL, D.—Zeitsch. für wissensch. Zool. 1873, pp. 254–288, pl. xiv. (Minute anatomy of nasal appendages of *Rhinolophus hipposideros*.)
- REGÀLIA, E.—Atti Soc. Tosc. (Proc. Verb.), ii. pp. xcii–xciv. (Formation of premaxilla and number of phalanges in digits of manus.) See also Atti Soc. Tosc. 1879, pp. cxxv–cxxvii. (Habits of *Vespertilio bechsteini*.)—Rend. Inst. Lomb. (2) xi. pp. 326–331. (Note on *Vesperugo savii*.)
- REGÀLIA, E.—Zool. Anz. iii. pp. 519–522, and in Atti Soc. Tosc. (Proc. Verb.), 1880, p. 111. (Rudiments of distal extremity of ulna.)
- REGÀLIA, E.—Atti Soc. Tosc. 1880, Proc. Verb. pp. 39–41. (*Vespertilio abramus*), and Revist. Sci. Industr. Agosto 1878.
- REINHARDT.—Vidensk. Meddel. fra d. naturhist. Foren. i Kjöbenh. 1865–6, pp. 241–244. (Stomach of *Desmodus*.)
- ROLLINAT, R., and TROUESSART, E.—“Sur la Reproduction de Chiroptères.” C. R. Soc. Biol. (10) ii. pp. 53, 54, and 534–536.
- SCHÄFER, E. A.—Quain’s Anatomy. 10th ed. vol. iii. pt. iii. p. 91. (Stapedial artery.)
- SCHLOSSER, MAX.—“Die Affen, Lemuren, Chiropteren, Insectivoren, Marsupialen, Creodonten und Carnivoren des Europäischen Tertiärs,” Pt. I. Beitr. Pal. Oesterr.-Ung. vi. i. pp. 1–224, pls. i.–v.
- SCHÖBL, J.—In Schultze’s Archiv, vii. 1871, pp. 1–31. (Minute anatomy of the wing-membrane.) Taf. 1–5.
- SCULLY, J.—“On the Chiroptera of Nipal.” Journ. Asiat. Soc. Bengal, lvi. pp. 233–259. (Distributional and critical, said to contain a review of previous work, cf. Zool. Rec. 1887.)
- SMITH, G. ELLIOT.—“Origin of Corpus Callosum. A comparative study of the Hippocampal region of the Cerebrum of Marsupialia and certain Chiroptera.” Trans. Linn. Soc. 1897, vii. pt. 3, ser. 2, Zool. pp. 47–69, 2 pls. (*Minopterus schreibersii* and *Nyctophilus timorensis*.)
- SMITH, J. A.—P. Phys. Soc. Edinb. 1880, pp. 362–371. (Notes on *Epomophorus comptus*.)
- THOMAS, O.—Ann. Mus. Genov. (2) iv. pp. 201–207 (with DORIA, note on *Molossus temmincki* and *Scotophilus pallidus*). Also many papers in Ann. N. H., P. Z. S., and Ann. Mus. Genov.
- TROUESSART, E. L.—Catalogue des Mammifères vivants et fossiles. Fasc. i. Paris 1878, 8vo, pp. 82. See also Revue et Mag. de Zoologie, (3) vi. pp. 201–254.
- TROUESSART, E. L.—Villénêque, Maine-et-Loire, 1879. (Synoptical

review of European Bats, reprinted from Feuille Nat. 1879.)

See also in Le Nat. i. pp. 125-126 (4 French species).

TROUËSSART, E. L.—Ann. Sci. Nat. (6) viii. art. 12, pp. 1-24.
(Distribution based on Dobson's Catalogue.)

TRUE, F. W.—P. U.S. Nat. Mus. x. p. 515. (*Vesperugo hesperus*.)

TUCKERMAN, F.—“Observations on the Gustatory Organs of the Bat.” (*Vespertilio subulatus*.) J. Morph. ii. pp. 1-6, pl. i.

VOGT, C.—“Recherches sur l'Embryogénie des Chauves-souris.” C. R. Assoc. Franc. 1881, p. 655.

WEITHHOFER, A.—“Zur Kenntniss der fossilen Chiropteren der französischen Phosphorite.” S.B. Ak. Wien, 1887, pp. 285 & 286. See also *loc. cit.* p. 352.

WINGE, H.—“Jordfundne og nulevende Flagermus (Chiroptera) fra Lagoa Santa, Minas Geraes, Brazilien. Med Udsigt over Flagermusenes indbyrdes Slægtskab.” E Museo Lund, en Samling, vol. ii. pp. 1-65, pls. i. & ii. (Said to contain references to other writers, *cf.* Zool. Rec. 1892.)

ZITTEL, R. A.—Handbuch der Paläontologie. 1st Abtheil. Paläozoologie, Band iv. Lief. i. : Munich, 1892, 8vo, 304 pp.

ZUCKERKANDL.—“Ueber das Riechcentrum.” See G. E. Smith, *loc. cit.*

February 15, 1898.

Dr. A. GÜNTHER, F.R.S., V.P., in the Chair.

The Secretary read the following report on the additions to the Society's Menagerie during the month of January 1898:—

The total number of registered additions to the Society's Menagerie during the month of January was 64, of which 26 were by presentation, 33 by purchase, and 5 were received on deposit. The total number of departures during the same period, by death and removals, was 78.

The Secretary read the following extract from a letter addressed to him by Mr. D. Le Souëf, dated Melbourne, Nov. 27, 1897:—

“I some time ago had an embryo Kangaroo sent me, which I have photographed, and send on, in case it may be of interest to you. The Kangaroo was seen sitting under the shade of a tree, and had her head apparently in her pouch, which she seemed to be holding open with her fore-paws. She was shot dead and fell over. On examining her pouch the little embryo was found lying loose—the mother had apparently been putting it on to the teat with her lips when shot. The teat was much contracted at the end, which would enable the parent to fix the young one on to it. The Kangaroo was sitting on her tail, that member being stretched out in front of her—a favourite position of the Kangaroo family. She was probably in the same position when the young one was born,

and therefore it would not touch the ground, but immediately on birth could be at once transferred to the pouch" ¹.

Mr. Arthur Thomson, the Society's Head Keeper, laid on the table a series of specimens of various Insects reared and exhibited in the Insect-house in the Society's Gardens during the past year and read the following report on the subject:—

Report on the Insect-house for 1897.

Examples of the following species of Insects have been exhibited in the Insect-house during the past season:—

Silk-producing Bombyces and their Allies.

Asiatic.

Attacus atlas.
— *cynthia.*
— *ricini.*

Attacus pernyi.
Antheræa mylitta.

American.

Samia cecropia.
— *ceanothi.*
Actias luna.
Anisota stigma.

Telea polyphemus.
— *promethea.*
Hypochiria io.
Eacles imperialis.

African.

Attacus mythimna.
Antheræa menippe.
— *cytherea.*
Cynanisa isis.

**Imbrasia epimeathea.*
**Bunea phædusa.*
Eudæmonia brachyura.
Lasiocampa monteiri.

Diurnal Lepidoptera.

European.

Papilio podalirius.
— *machaon.*

Thais polyxena.
— *cerisyi.*

American.

Papilio zolicaon.
— *cresphontes.*
— *asterias.*

Papilio turnus.
— *ajax.*
Limenitis disippus.

Nocturnal Lepidoptera.

Sphinx ligustri.
— *carolina.*
* — *lucitiosa.*
Smerinthus ocellatus.
— *exceccatus.*
* — *myops.*

Ceratonia amyntor.
— *undulosa.*
Deilephila euphorbiæ.
— *galii.*
— *elpenor.*
— *porcellus.*

* Exhibited for the first time.

¹ Cf. Pinkert, E., "Beobachtungen bei der Geburt eines Känguruh, *Macropus rufus*," Zool. Gart. xxx. p. 85.—Ed.

Of the Lepidopterous Insects which I have the honour to place before the meeting, *Sphinx lucitiosa* and *Smerinthus myops*, from North America, *Imbrasia epimeathea* and *Bunea phædusa* from Sierra Leone, were exhibited for the first time in 1897.

During the past summer five specimens of the Goliath Beetle, *Goliathus druryi*, have been exhibited. They fed well upon bananas, but I am sorry to say they are all dead. The single male received I exhibit this evening.

One of the most interesting exhibits of the past summer and at the present time is a colony of the Parasol Ant (*Ecodoma cephalotes*). These ants were presented by Mr. F. W. Ulrich, and were brought to England from Trinidad, by Mr. R. R. Mole, C.M.Z.S., and were received on May 11, 1897.

I had a zinc tray made for the curious insects, with a moat round it, which was filled with water to prevent their escape. At one end of the tray I placed the package containing the ants on a little table, and at the other end a small growing rose-tree in a pot. The pot and the table were connected by means of a dead tree-branch. The ants soon found their way across this bridge and immediately set to work to close up the openings of the box in which they had travelled with the mould in which the rose-tree was growing. In a day or two the ants began to cut pieces out of the leaves of the rose-tree, and these they carried across the bridge, into what I might call their nest.

Towards the autumn the ants appeared to get tired of their quarters, and persistently carried the refuse from the nest and dropped it into the water, with the idea, I think, of bridging it over and thus getting across. I then put into the middle of the tray a pot of fresh mould, and cut the bridge into two pieces, but no notice was taken of this. The ants still kept throwing the refuse into the water, and would no doubt, if left alone, have soon made a way across the moat.

When rose-leaves were not obtainable, the ants were fed upon orange-peel, and carried into the nest the *inside* pith of the peel.

Of Spiders, examples of two very interesting species have been exhibited. The first received was a specimen of *Scodra calceata*, from West Africa, presented by Mr. F. W. Marshal on the 27th March, which died on the 12th Sept., 1897. The second was a very fine specimen of *Pæcilotheria striata* from India, presented by Mr. H. R. P. Carter on the 21st Oct. last. This fine Spider, I regret to say, only lived two days in the Gardens. An interesting account of this Spider will be found in the 'Field' of Oct. 30, 1897 (vol. xc. p. 705).

The Secretary exhibited a series of Lepidopterous Insects prepared and set by Mr. S. W. Denton, of Wellesley, Mass., U.S.A., in illustration of the system adopted in 'Denton's Patent Butterfly Tablets,' as well adapted for public museums where close examination was not required.

The following papers were read :—

1. Contributions to the Osteology of Birds.
Part I. *Steganopodes*. By W. P. PYCRAFT.

[Received February 12, 1898.]

(Plates VII. & VIII.)

It has recently fallen to my good fortune to be set the task of determining and arranging the large collection of birds' skeletons at the British Museum. I propose to embody the results of my work in a series of papers of which this is the first. Before going further, I would like to remind those interested that I shall be most grateful to receive, on behalf of the Collection, embryos, nestlings, and adults of all Orders, for there are many gaps left by imperfect specimens, and otherwise, which much need to be filled up.

The Pelicans, Tropic-birds, Frigate-birds, Cormorants, Darters, and Gannets all agree in one point—all four toes are united in a common web. This fact has been deemed by some of sufficient importance to justify their separation from the rest of the Carinatae, to form a special group by themselves—the *Steganopodes*. Others, on account of anatomical differences which obtain amongst certain of the groups thus brigaded together, are inclined to doubt whether this separation is a valid one, whether the value of this single external character is sufficiently great to be regarded as a primary dividing factor. The stumbling-blocks which threaten the general harmony are *Phaëthon* and *Fregata*.

I hope, in the present paper, to show that, after all, the "totipalmate" foot may be adopted as the shorthand sign of the group: to show that (1) all are closely related; that (2) they cannot be broken up to form one or more suborders or subdivisions of equal value, but that (3) they must be regarded as a whole, as a suborder or subdivision of some larger group; and that (4) they cannot consistently be merged as a whole with that larger group.

The most important witness to the integrity of the Suborder is the skull. Three types can be easily distinguished :—

1. Basitemporal plate shield-shaped, with a free edge anteriorly forming a floor to the Eustachian tubes, or rather grooves.
2. Basitemporal plate triangular, its lateral borders fused with the basisphenoid, free anteriorly and contributing to form the mouth of the Eustachian aperture.
3. Basitemporal plate not extending forwards more than half the length of the basisphenoid, with which it is so completely fused in the adult as to be traceable only as a thin line running across the basisphenoid.

The first of these is the most primitive, and agrees precisely with

what is found in the Storks and Herons, Procellariæ, &c. The 2nd and 3rd are modifications of the 1st.

The skull of the first type (Pl. VII. fig. 3) may be regarded as typical of the Steganopodes, and is characterized as follows:—

The palate is desmognathous, the palatines are broad, flattened, and meet in the middle line from the posterior narial aperture backwards to the pterygoids; there is no vomer; the maxillo-palatine processes have become metamorphosed into a spongy mass fusing with a much swollen nasal septum—similar to that of *Balaniceps*—and not extending backwards into the lachrymo-nasal cavity as usual, but yet preserving, as in *P. carbo*, a slight free posterior border; the orbital process of the quadrate is small, styliform, placed at a right angle to the long axis, and about halfway down; the anterior narial apertures are obsolete; and the upper jaw is more or less sharply defined from the skull by a fronto-nasal hinge.

Phalacrocorax and *Plotus* belong to this first type, and the above description applies to both; the points whereby the two genera may be distinguished will be found in the appended “key.” It may be remarked here, however, that in *Plotus* the maxillo-palatine processes project backwards into the lachrymo-nasal cavity as thin vertical laminae. There are two points, however, wherein this family differs from the others. Such are the presence of a supraoccipital style and of a “suprajugular.” The first is a short, more or less triangular bony rod articulating with a small tubercle on the supraoccipital: the second, as found in *Plotus*, is a more or less elongated, oat-shaped lamina of bone, lying in the lachrymo-nasal fossa, on the jugular process of the maxilla. It was first described, many years ago, by Brandt (3), and appears to have escaped the notice of nearly every writer on the Osteology of this group since. Mr. Beddard refers to it in his recent paper in the P. Z. S. 1888 (1); Fürbringer also refers to it (6). Dr. Gadow writes me that he thinks it is probably “nothing more than an additional splint-bone.” I have been wondering whether it is a remnant of a “maxillo-nasal” such as is described and figured in the magnificent monograph on the Dinornithidæ by the late lamented Prof. T. J. Parker. In *Phalacrocorax* it is represented only by a long needle-like splint.

Our second type is found in the skulls of *Phaëthon* and *Pelecanus*, but, beyond this, the two skulls appear to have little else in common.

The skull of *Phaëthon* (Pl. VII. fig. 2) appears to be the least specialized of the whole group, and presents characters which are not only found in all, or nearly all the other Steganopodes, but which also occur in forms outside this suborder. The most important of these is the presence of a large tubular recess lying immediately in front of the quadrate articular surface, and running upwards between the squamosal and prootic bones. In it is lodged the accessory bundle of the temporalis muscle.

This recess is found in *Sula* and *Fregata*, where it is of con-

siderable size; and in *Phalacrocorax*, *Plotus*, and *Pelecanus*. Amongst these it is of moderate size only in *Phalacrocorax carbo*; in the other forms it varies, occurring in almost every gradation down to a minute aperture. In *Plotus anhinga* it appears to be wanting altogether. Outside the group it occurs in the *Ciconiæ*, *Procellariæ*, and *Sphenisci*, &c.

The maxillo-palatine processes differ—in the adult at least—from the other Steganopodes, and resemble rather those of the Ibises and Herons, in that they only extend horizontally, and only slightly vertically. They are completely fused throughout the greater part of their extent, but send backwards, into the lachrymo-nasal fossa, two free spongy masses. The nearest approach, as previously hinted, to this arrangement is found in the Ibises and Herons.

Whilst in all the other Steganopodes the palatines are more or less completely fused posteriorly, in *Phaëthon* they are quite free, and in *Fregata* nearly so.

A vomer occurs only in *Phaëthon* and *Fregata*. In the former it is cleft posteriorly; in both, in the adult, it is completely fused posteriorly with the palatines. In *Phaëthon* it is somewhat “knife-blade-shaped,” and received between the ends of the maxillo-palatine processes. The dorsal edges of the cleft posterior ends are closely applied to the basisphenoidal rostrum. A bicarinate vomer is found also in the Herons. The vomer is fused with the palatines posteriorly, outside the Steganopodes, in all the other Ciconiiformes, the Anseriformes, Procellariiformes, and Sphenisciformes.

The anterior nares are large, and pervious, in which respect they resemble also those of the Pelicans.

The skull of a nestling *Phaëthon*, prepared under my direction, revealed some very instructive facts, which will be best understood by a reference to the figures (Pl. VIII. fig. 1a). That of the ventral view of the skull shows that at this stage the palate is *schizognathous*. The maxillo-palatine processes are small, triradiate, perfectly separate in the middle line, and do not give the slightest promise of the “spongy” nature which they afterwards acquire, when they have fused one with another, to form the *desmognathous* palate. The aperture of the anterior nares, again, is much larger, and extends farther backwards than in the adult, so much so indeed as nearly to convert the *holorrhinal* into *schizorrhinal* nares. The nasal hinge, so strongly marked a feature in the adult skull, is here conspicuous by its absence. A second skull, somewhat older than this, shows stages intermediate between this and that of the adult.

The skulls of the adult *Pelecanus* and *Phaëthon* do not appear to possess much in common, except the form of the basitemporal plate; but this point is, I think, a rather important one.

The maxillo-palatine processes in *Pelecanus* very closely resemble those of the *Ciconiæ*. They consist of delicately cancelled tissue of considerable vertical extent, extending the whole

height of the upper jaw in fact, and backwards into the lachrymo-nasal fossa, and are of course fused in the middle line ventrally. Seen from behind (Pl. VIII. fig. 6), they are quite distinct one from another. In some specimens, what I take to be traces of an osseous septum nasi are found. As in the Storks, the maxilla and maxillo-palatine processes make up the greater part of the upper jaw. The nasal hinge is generally well marked.

The palatines are completely fused from the posterior narial aperture backwards, and, further, are provided with an enormous dorsal and ventral median keel. A trace of this, as we shall see, is found in *Sula*.

The skull of *Sula*, in the obliteration of the anterior narial apertures, the form of the maxillo-palatine processes and of the palatines, closely resembles that of *Phalacrocorax*. These are some of the latest acquirements of the group, and tend, amongst other things, to single out the two families which they represent as conspicuously "Steganopodous." They may perhaps be regarded as the most intensely modified members of the suborder.

The maxillo-palatine processes of *Sula* differ from those of *Phalacrocorax* in that their coalescence is more complete. Seen from behind, they present an obliquely truncated surface of cancellated or lattice-like tissue, which ventrally does not even extend as far backwards as the posterior end of the maxilla itself. Moreover, a closer examination shows that the bony tissue of the interior of these processes has been more or less completely absorbed, so that the truncated posterior end just described is practically a mere shell or screen concealing the hollow space within. There is no trace of an osseous septum nasi. The palatines are completely fused in the middle line from the posterior narial aperture backwards, and there is a slight median dorsal and ventral keel, just as in *Pelecanus*, but less developed. In *Phalacrocorax* this region of the palatines is rarely, if ever, fused throughout its whole length. An open suture is generally visible. In *Plotus* it appears to be constantly fused. The fronto-nasal hinge is strongly marked.

The basitemporal plate and basisphenoid appear to be an extremely modified form of that obtaining in *Fregata*. The former was very small, not more than half covering the latter, with which it had so completely fused that what should be its free edge is only traceable as a thin faint line. The apertures of the Eustachian tubes appear to have become completely obliterated, leaving only a faint scar on the basisphenoidal rostrum.

Sula and *Phalacrocorax* are the only Steganopodes in which the postorbital process is emarginate. This is a common feature amongst the Ciconiæ and Ardeæ, e. g. *Pseudotantalus*, *Nycticorax*, *Cancroma*.

In the skull of a very young nestling *Sula* I found the palate to be *schizognathous*, as in *Phaëthon*, which it closely resembled in the triradiate form of its maxillo-palatine processes. Another point of very considerable significance was the fact that the

anterior narial apertures extended almost the whole length of the upper jaw, while, as has already been remarked, in the adult they are quite obliterated (Pl. VIII. fig. 2).

In the skull of *Fregata* (Pl. VII. fig. 1) the free posterior extremities of the maxillo-palatine processes closely resemble those of *Phaëthon*. They differ, however, markedly in the fact that they extend vertically as well also as horizontally, reaching upwards to the roof of the upper jaw. They are divided by a distinct and osseous septum nasi, swollen dorsally. Vestiges of a precisely similar septum are found in *Phalacrocorax* and *Pelecanus*. There is a long, slender, curved vomer, anteriorly resting upon the posterior ends of the fused maxillo-palatines and posteriorly fused with the palatines. The pterygoid ends of these last, again, are perfectly ankylosed, just as they are in many *Ciconiæ*.

The basitemporal plate in *Fregata*, like that of *Sula*, does not cover the whole basisphenoidal surface. Unlike that of *Sula*, however, it still preserves a free edge, though this is very slight. A short distance in front of the anterior border of this plate, in a slit-like depression of the basisphenoidal rostrum, lie the Eustachian apertures, though so small that only a very slender bristle can be passed through them. If this skull be compared with that of *Sula*, faint traces of the Eustachian tubes in this latter genus will be found, as well as a faint ridge, representing the once free edge of the basitemporal plate.

The nature of the mandibular articular surfaces of the quadrate deserves some notice, since, if this had been adopted instead of the form of the basitemporal plate, and basisphenoid, for the purposes of systematic arrangement, the results would have been almost identical. These surfaces are two in number, the quadrato-jugal and the pterygoid.

In *Phaëthon* and *Pelecanus* the quadrato-jugal surface is directed obliquely outwards and forwards; that of *Pelecanus* being much broader in proportion to its length than that of *Phaëthon*. The pterygoid surface is placed almost at right angles to the long axis of the skull. The two surfaces are divided by a groove, which is most marked in *Pelecanus*. The general impression of the articular end of this bone as a whole is that of a narrow bar continued backward from the pterygoid to the quadrato-jugal bar, which it joins almost at right angles.

In *Fregata*, *Sula*, and *Phalacrocorax* the surfaces have a V-shaped arrangement. In *Phalacrocorax* the V has almost become U-shaped. The pterygoid surface is subcircular, the quadrato-jugal hour-glass-shaped.

Though the articular surfaces of the quadrate in *Sula* and *Fregata* closely resemble one another, that of *Fregata* can at once be distinguished by the form of the orbital process, which is very large, with a broadly expanded free end resembling that of the Heron. In *Sula*, as in *Phalacrocorax* and *Plotus*, the orbital process is reduced to a small spur standing out at right angles to the long axis of the bone and about halfway down.

The atlas vertebra of the Steganopodes has the odontoid ligament ossified; the neural arch is very broad and flattened, and devoid of a crest. The axis has a fossa immediately underlying the odontoid process, into which pneumatic foramina frequently open. The remaining vertebræ in the different genera and species vary greatly *inter se*, and do not seem to afford any characters which can be regarded as peculiar to the group (see table, p. 99).

In the sternum of the Steganopodes the carina is produced far forwards beyond the *corpus sterni*; it decreases in depth rapidly from before backwards, terminating not far behind the middle of the *corpus sterni*—save in *Phaëthon* and *Fregata*. The acrocoracoid bears a large facet for articulation with a corresponding facet on the outer side of the dorsal extremity of the furculum. The furculum articulates or is even ankylosed with the carina in *Pelecanus* and *Fregata*.

Fig. 1.

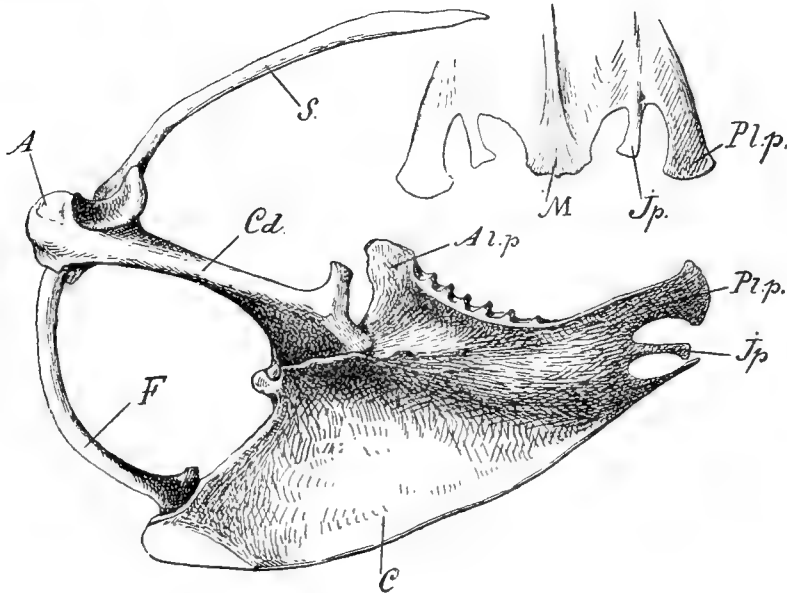

Sternum of *Phaëthon flavirostris*, left side view (nat. size). The small outline immediately to the right represents the form of the posterior border of the sternum, ventral view.

A., Acrocoracoid; C., Carina; Al.p., Anterior lateral process; Pl.p., Posterior lateral process; Ip., Intermediate process; F., Furculum; S., Scapular; M., Metasternum.

In *Phaëthon* the carina is of the same form, but continued backwards farther than in any other Steganopod save *Fregata*; dorsally the furculum does not articulate with the acrocoracoid by means of apposed flattened facets; ventrally it articulates with the anterior border of the sternum, and not with the extreme antero-ventral angle as in the other forms. The anterior end of

Fig. 2.

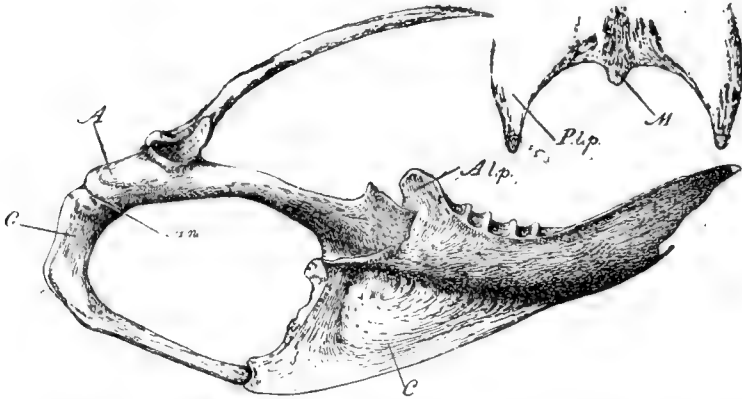

Sternum of *Phalacrocorax carbo*, left side view. $\frac{1}{2}$ nat. size.

C. Clavicle; *Am.*, Coraco-clavicular articulation: other letters as in Fig. 1. The small outline immediately to the right represents the form of the posterior border of the sternum, ventral view.

Fig. 3.

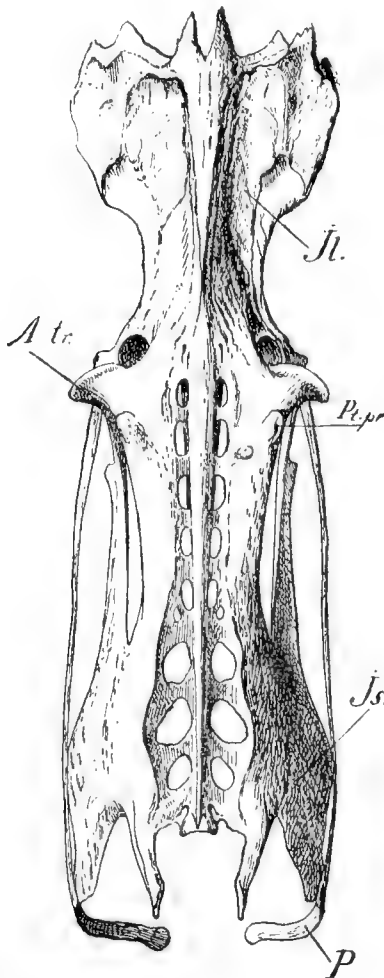

Dorsal aspect of the pelvis of *Phalacrocorax carbo*. $\frac{2}{3}$ nat. size.

Atr., Antitrochanter; *Il.*, Ilium; *P.*, Pubis; *Is.*, Ischium; *Pt.pr.*, Post-trochanteric process.

the free ventral border of the carina of the sternum is peculiar in that its edge becomes suddenly transformed from a broad to a sharp one, as though it had been shaved off on either side by a knife (see figs. 1, p. 87, & 2, p. 88). The posterior end of the corpus sterni is doubly notched.

The sternum of *Fregata* is unique in that the furcula is ankylosed dorsally with the acrocoracoid, and ventrally with the carina sterni.

As will be seen by the "key," there are three types of pelvis—that of *Phaëthon* and *Fregata* constituting one, that of *Pelecanus* a second, and those of *Phalacrocorax* and *Sula* a third. This last must be regarded as the typical Steganopodous pelvis (fig. 3, p. 88).

The pelvis of *Pelecanus*, resembles somewhat closely that of *Sula*, and after this, that of the *Anseres*; but differs in the greater width of the preilium, and in that the postilium is not laterally expanded and truncated posteriorly as in the latter group.

The pelvis of *Phaëthon* (fig. 4, p. 89) and of *Fregata* closely resemble one another, and both differ much from that of any other Steganopod. That of *Phaëthon* most nearly resembles that of *Mo-*

Fig. 4.

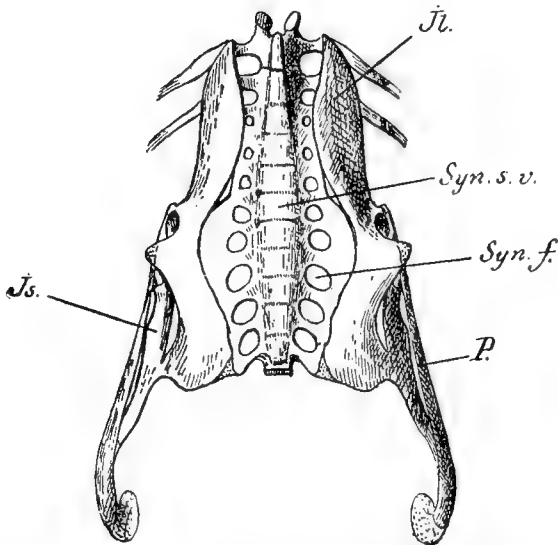

Dorsal aspect of the pelvis of *Phaëthon flavirostris* (nestling). $\frac{3}{4}$ nat. size.

Il., Ilium; *Syn.s.v.*, Synsacral vertebræ; *Syn.f.*, Synsacral foramen;
P., Pubis; *Is.*, Ischium.

motus, but differs therefrom in that the postacetabular ilium is much flattened and bent downwards and outwards, in that the ischium is much longer than broad, instead of being nearly as broad as long, and in the greater length of the pubis. This resemblance can scarcely be regarded as other than an accidental one. What is

more to the purpose is the fact that there are many points of resemblance between the pelvis of *Fregata* and that of certain *Procellariæ*, e. g. *Bulweria*. That this indicates a relationship, though remote, is not improbable. This being so, *Fregata* may be regarded as a link connecting *Phaëthon*, which is undoubtedly one of the least specialized and most primitive of the *Steganopodes*, with the *Procellariiformes*.

The humerus assumes two forms:—

(1) The pectoral crest is triangular in form, and the crista inferior more or less inflated—*Fregata*, *Phaëthon* (fig. 5), *Pelecanus* (fig. 6); and (2) with the pectoral crest represented by a slight ridge but little raised above the level of the shaft, and the crista inferior hardly or not at all inflated—*Sula*, *Phalacrocorax*, *Plotus* (fig. 7).

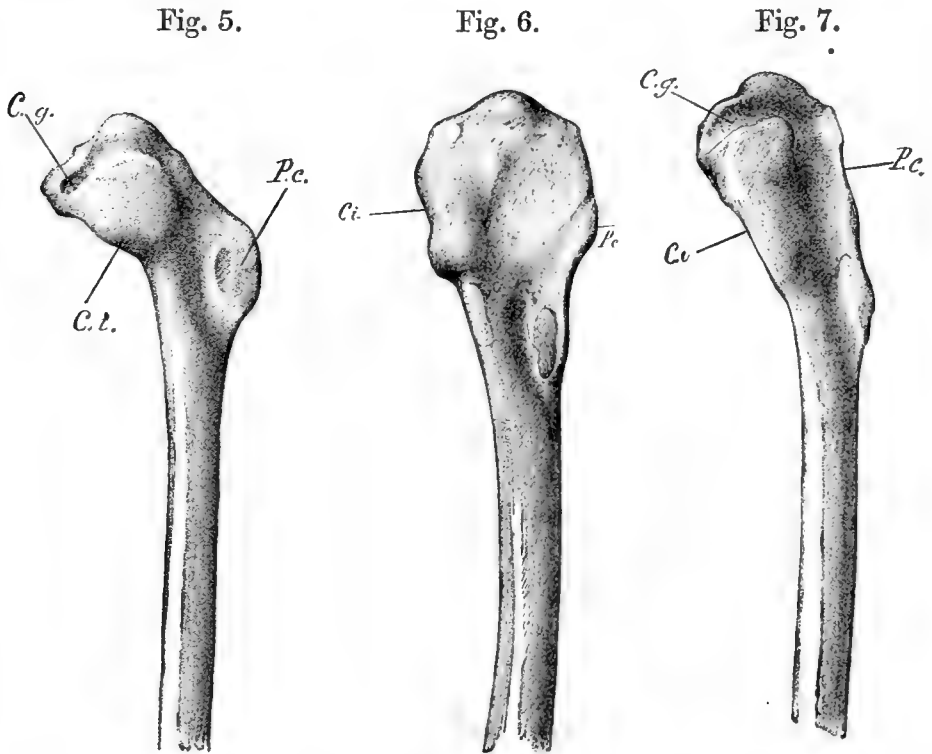

Anterior aspects of the proximal end of the humeri of (5) *Phaëthon flavirostris*, nat. size, (6) *Pelecanus rufescens*, $\frac{1}{3}$ nat. size, and (7) *Phalacrocorax carbo*, $\frac{2}{3}$ nat. size.

C.i., Crista inferior; *P.c.*, Pectoral crest; *C.g.*, Coraco-humeral groove.

The forearm and manus offer no characters sufficiently marked to be diagnostic: that of *Phaëthon*, for instance, is not easily distinguishable from that of many *Limicolæ*, and that of *Pelecanus* from that of many *Ciconiæ*.

The pelvic limb of the Steganopodes is peculiar in having a long hallux directed forwards—which, in the living bird, is embraced with the remaining digits in a common web. The tibio-tarsus is inflected distally as in Anseres, some *Rallidæ*, and *Spheniscidæ*.

The tibio-tarsus of *Phaëthon* may be readily distinguished from that of either of the groups just mentioned by the feeble development of its cnemial crests. In the remainder of the Steganopodes the tibio-tarsus can be readily distinguished from that of either the Anseres or *Rallidæ* by the great length of the fibula. This, however, does not apply to the *Spheniscidæ*, in which the fibula is also very long; from that group the Steganopodes can be at once distinguished from the fact that there is a considerable space always visible between the fibula and the tibio-tarsus, running from the lower end of the fibular ridge to the point where the fibula joins the distal end of the tibio-tarsus.

The tarso-metatarsus of *Fregata* resembles that of the Penguins, the three metatarsals being more or less distinct and separated by grooves one from another. It may, however, be readily distinguished therefrom by the fact that the 2nd trochlea is longer than the 3rd and is directed backwards; and by the presence of a foramen between the 3rd and 4th trochleæ.

The tarso-metatarsus in all save *Fregata* is marked by a fossa at the proximal articular end of the anterior surface into which open foramina, pneumatic or otherwise. The hypotarsus is complex in all. Save in *Phaëthon* and *Fregata*, it is characterized by the considerable development of the gastrocnemial ridge.

The object of this paper was to show that the Steganopodes must be regarded as a natural group. Taking *Phalacrocorax* as its type, a fixed point will be gained by which to measure, roughly, the amount of specialization which the various members have undergone. *Plotus* may perhaps be regarded as having passed beyond the mean, it is a highly specialized Cormorant; *Sula* has about reached the level of *Phalacrocorax*; *Pelecanus*, though possessing the peculiar palate of *Phalacrocorax* and *Sula*, is in most other respects less modified; *Fregata* and *Phaëthon* are the lowest members of the group, they represent two divergent branches of a common stem. *Sula*, on account of the form of its basitemporal plate, seems to have affinities with *Fregata* (Pl. VII. fig. 1); *Pelecanus*, for similar reasons, with *Phaëthon* (Pl. VII. fig. 2). All, save *Phaëthon* and *Fregata*, have lost the vomer. Fürbringer and Gadow both agree in regarding *Phaëthon* as the most aberrant of the sub-order, and Mr. Beddard goes perhaps further: he writes (1):—"So different are the skull characters of *Phaëthon* from those of the typical Steganopodes that, were it not for *Fregata*, the bird would have to be ignominiously expelled from the order. This catastrophe is averted by *Fregata*, the skull of which, as will have been gathered from the foregoing remarks, serves to link *Phaëthon* with the Cormorants, Gannets, and Pelicans." I cannot but feel, however, that, taking all the skeletal characters into consideration, this family is much more closely allied to the Steganopodes than to that of any other Order. With this the

first part of my paper closes. Whether I have succeeded in the task that I set before me at the beginning of this paper remains for my readers to decide. The accompanying diagram (fig. 8) is an attempt to show the possible lines of divergence within the Suborder, and the probable relationships of the different Families.

Fig. 8.

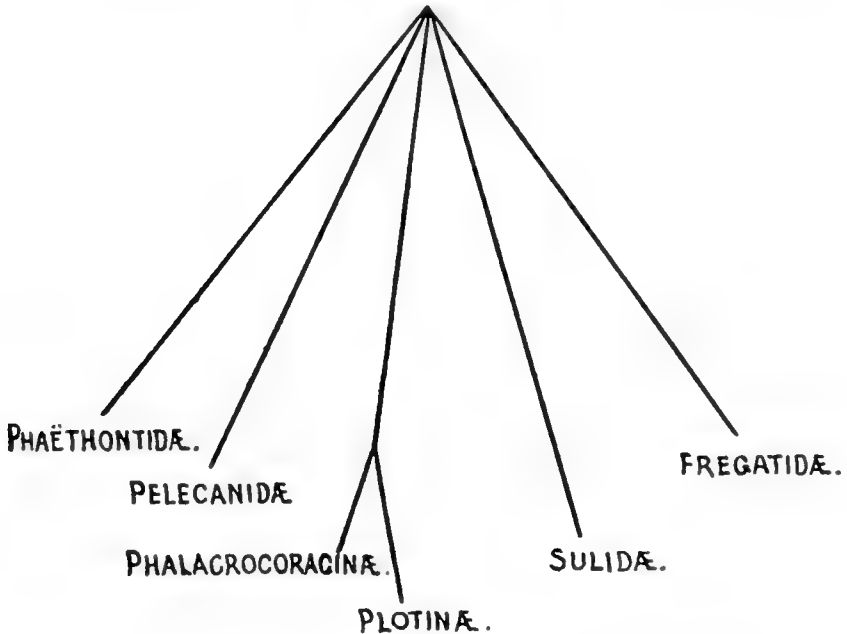

Diagram showing the probable relationships between the various Families of the Suborder Steganopodes.

We must now turn to a question recently raised by Mr. Beddard (1). Are the Steganopodes desmognathous birds? The answer to this, he tells us, depends upon the definition of the term "desmognathous." According to Huxley (10), in the desmognathous skull "the vomer¹ is often abortive, or so small that it disappears from the skeleton. When it exists, it is always slender and tapers to a point anteriorly. The maxillo-palatines are united across the middle line, either directly or by the intermediation of ossifications in the nasal septum."

Those who will turn to Huxley's original paper will find that he considered that the desmognathous skull was to be found "under its simplest form in *Palamedea* and the *Lamellirostres*. In these birds each maxillo-palatine is a broad, flat, and thin bony

As a matter of fact, the vomer need not be taken into consideration at all.

plate which unites with its fellow in the middle line of the palate." In other words, the maxillo-palatine process represents the internal palatine border of the maxilla. In some Ducks, and in Geese, these processes are prolonged backwards beyond the fused posterior border so as to embrace the vomer between them. Such backwardly directed processes may be further studied in *Ardea*, *Ciconia*, *Accipitres*, *Phaëthon*, and *Fregata* (Pl. VIII. figs. 1 & 4).

It is on account of these backwardly directed processes that Mr. Beddard has been led to ask, "But can *Phaëthon* be accurately termed a desmognathous bird?" Later on he answers it, "*Phaëthon* is really no more desmognathous than is *Æchmophorus* (a schizognathous bird), if we apply the term as Huxley applied it; for the maxillo-palatines in both are widely apart, the vomer lying between them." He continues, "In front of the maxillo-palatines, however, in *Phaëthon* the bony palate forms a continuous platform."

Mr. Beddard's error is, I think, obvious: he has, for the moment, allowed himself to regard the backwardly directed prolongations as if they represented the entire maxillo-palatine process (Pl. VIII. fig. 5). The bony palate which "forms a continuous platform" is really formed by the processes in question, whilst the bones so-called in his paper are but parts of the same.

When discussing the nature of the palate in *Sula* and *Phalacrocorax*, he writes:—"If we are to apply the term desmognathous to these birds, it must be on the understanding that it is a different kind of thing from the desmognathism of—say—the *Anseres*." His reasons are the following:—the maxillo-palatines in *Phalacrocorax*, *Plotus*, and *Sula* consist of a "thick mass of bone running upwards towards the roof of the skull. Their direction is quite different from the horizontally disposed maxillo-palatine of *Phaëthon*. The conditions observable in the base of the skull of *Fregata* appear to me to clear up this somewhat puzzling discrepancy. In *Fregata*, we have both the horizontal maxillo-palatines of *Phaëthon*, separated from each other in the middle line as in that genus, and the obliquely running 'maxillo-palatines' of *Phalacrocorax*. As co-existence undoubtedly disproves homology, it seems to me to follow that true maxillo-palatines, comparable to those of other birds, are wanting in *Sula* and *Phalacrocorax*."

I feel perfectly certain that if Mr. Beddard had carefully examined the skull of *Fregata* (Pl. VIII. fig. 4) he would have seen that the horizontal maxillo-palatines and the "obliquely running maxillo-palatines" were both parts of one and the same bone; that the "horizontal maxillo-palatines" were nothing more than backward continuations of the main body of this bone as seen in *Ardea*, &c. This being so, then the maxillo-palatines of *Sula* and *Phalacrocorax* (Pl. VIII. fig. 3) differ only in that they are sharply truncated posteriorly—have no "horizontal" processes. In *Plotus* vestiges of these last yet remain,

*Key to the Osteology of the Steganopodes.*¹

A. SKULL (Plates VII. & VIII.).

- A. Basitemporal plate triangular, its lateral borders fused with the basisphenoid, free anteriorly and contributing to form the mouth of the Eustachian apertures.
- a.* Upper jaw pointed and with a deep nasal hinge; nostrils pervious; palatines separate, embracing a large vomer; lachrymal free; a minute unciform (Beddard) *Phaëthon.*
- b.* Upper jaw very long, depressed, hooked at the tip; nasal hinge imperfect; nostrils impervious; palatines fused in the middle line, with a strong median keel; vomer absent; lachrymal fused *Pelecanus.*
- B. Basitemporal plate shield-shaped, with a free edge anteriorly, forming a floor to the Eustachian tubes or grooves; no interorbital septum.
- a.* Aperture of the external nares minute, impervious; palatines meeting in the middle line from the level of the lachrymal backwards, with an ossified supraoccipital style; lachrymal fused with frontal.
- a'.* Upper jaw hooked at the tip; a nasal hinge; lachrymo-nasal fossa large; temporal fossa narrow and deep; suprajugal in the form of a splint-like style; otic process of quadrate lying to the inner side of the squamosal head; orbito-sphenoid incomplete *Phalacrocorax.*
- b'.* Upper jaw pointed; no nasal hinge; lachrymo-nasal fossa partly enclosed by a large suprajugal; temporal fossa very shallow, lateral walls of optic foramen produced forwards to form a tube; otic process of quadrate lying behind squamosal head; orbito-sphenoid complete *Plotus.*
- C. Basitemporal plate not extending forwards more than half the length of the basisphenoid, with which it is so completely fused in the adult as to be traceable only as a thin line or ridge running across the basisphenoid.
- a.* Aperture of the external nares almost or quite obliterated; palatines fused in the middle line from the level of the lachrymal backward, with a strong mesial keel; vomer absent; lachrymal fused; postorbital process emarginate, projecting far outwards beyond the cranium; orbito-sphenoid complete, with a nasal hinge; with an interorbital septum. *Sula.*
- b.* Upper jaw strongly hooked at the tip, and concave dorsally; nasal hinge absent; orbital process of quadrate large, expanded at its free end. Aperture of external nares small, impervious; palatines not flattened, fused posteriorly, embracing a long, slender vomer; lachrymal free; with an imperforate interorbital septum. *Fregata.*

B. VERTEBRÆ.

A. Heterocœlous dorsals.

- a.* First dorsal free, remainder fused one with another, and with the synsacrum, but retaining distinct neural spines and transverse processes; styloid processes of the cervical vertebræ never styliform but fused more or less completely throughout their length either with the pleurapophyseal lamella, or with a lateral ventral lamella from the centrum. Hypapophyses never more than blunt processes, and occur only on the 2nd and 15-18. All the vertebræ are highly pneumatic and pierced by large pneumatic foramina *Pelecanus.*

¹ The "keys" appended are designed for the use of those desirous of determining—at least generically—parts of skeletons which may be either undetermined or doubtfully named; they are not meant to express the systematic relations of the various genera—save that of the skull. "Keys" to the genera can easily be compiled from these.

b. All the dorsals free; styloid processes short and blunt on all the cervical vertebræ from the fifth backwards; 5th to 7th vertebræ with a slender bony bar from the metapophysis backwards to the hyperapophysis, neural crests present only on the second, third, and fourth. Hypapophyses on the second and third cervicals, and from ninth cervical backwards to the synsacral vertebræ, longest on the dorsals ... *Phaëthon*.

B. Opisthocœlous dorsals, all of which are free.

a. Hypapophyses present only on cervicals 1-3. All cervicals, save atlas and axis, bear styloid processes; meta- and hyperapophyses feebly developed; hæmal arches absent *Fregata*.

b. Hypapophyses present, on cervicals 1-4 very large, on 17-18 very feeble. Styloid processes from vertebræ 1-12; those of 8-10 long and slender. Hæmal arches to vertebræ 8-12; distinct metapophyses from 4-13, from 7-11 large; no synsacral or dorsal hypapophyses *Sula*.

c. Hypapophyses 1-3 and 13-23 very large, compressed. Synsacral hypapophyses 4, decreasing in size backwards; hypapophyses 3-6 in the form of a median ridge; distinct styloid processes on all the vertebræ from 3-12, from 8-10 long, slender, those of the 9th extending as far back as the posterior articular surface of the centrum; no complete hæmal arches; neural crests from 2-7 distinct, in form of sharp ridges; hyperapophyses 3-10 very distinct: centrum elongated and compressed; 16-18 cervicals much flattened ventrally *Phalacrocorax*.

d. Hypapophyses of atlas and 15-16 large, those of the two latter much compressed; those of the 2nd and 19-21 and 23rd in form of a low median ridge, that of the 22nd with lateral expansions ventrad. Synsacral hypapophyses 3, the 3rd vestigial. Anapophyses of 9-14 forming closed canals. Centra 3-13 grooved ventrally. Styloid processes 2-10 and 13-15 distinct, those of 8, 9, 10 long and slender, 8th extending as far back as the level of the posterior articular surface of the centrum; neural crests slightly developed; anterior vertebræ with much elongated cylindrical centra *Plotus*.

C. STERNUM AND PECTORAL GIRDLE (figs. 1 & 2, pp. 87 & 88).

A. The free end of the clavicle not provided with a facet for articulation with the acrocoracoid; the furcular apophysis of the clavicle articulating with the anterior border of the carina sterni, and not with its antero-ventral angle. Carina sterni and region of corpus sterni bearing coracoid grooves not produced far beyond the level of the costal process of the sternum. Carina extending nearly the whole length of the corpus sterni, the posterior border of which is doubly notched (=posterior lateral and intermediate processes). Coracoids touching, with a supracoracoid foramen and large precoracoid process *Phaëthon*.

B. The free end of the clavicle with a facet for articulation with the acrocoracoid; and the furcular apophysis of the clavicle articulating with the antero-ventral angle of the carina sterni. Coracoids widely separate; no intermediate process to posterior border of the sternum.

a. Greater part of carina sterni and region of sternum bearing the coracoid grooves produced far forward beyond the anterior lateral processes of the sternum. Precoracoid well developed; no supracoracoid foramen *Sula*.

b. Less than half the carina lying beyond the level of the anterior lateral process of the sternum, the inner angle of the outer border of which is continuous with the outer angle of the coracoid groove.

a'. Furculum fused with carina sterni; carina about three-fourths the length of the corpus sterni; precoracoid well developed; a supracoracoid foramen *Pelecanus*.

- b'*. Furculum not fused with carina sterni; precoracoid feebly developed.
*a*². Carina scarcely extending beyond the middle of the corpus sterni.
Phalacrocorax.
*b*². Carina three-fourths as long as corpus sterni *Plotus.*

- C. Sternum broader than long, carina extending the whole length of corpus sterni. Furculum fused dorsally with the head of the coracoid and ventrally with the carina sterni *Fregata.*

D. PELVIC GIRDLE (figs. 3 & 4, pp. 88 & 89).

- A. Pelvis nearly as broad as long. Iliia widely separated one from another by the transverse processes of the synsacrum. Preilium narrow, postilium presenting a broad surface dorsally; about half of the total length of the pubis free, projecting beyond the postero-inferior angle of the ischium. Obturator foramen about twice the diameter of acetabulum.
- a*. Anterior and posterior renal fossæ separated one from another by a low ridge, and not divided up into compartments by ventral transverse processes of the synsacrum *Phaëthon.*
- b*. Posterior renal fossa separated into a number of narrow compartments by the ventral transverse processes of the synsacrum *Fregata.*
- B. Pelvis much longer than broad. Preilia meeting in the mid-dorsal line, postilia not widely separated and presenting a broad dorsal surface.
- c*. Pelvis more than twice as long as broad; dorsal surface of postilium very broad. Ischiadic foramen about three times as long as the diameter of the acetabulum. Preilium of about equal width throughout, postilium presenting a broad dorsal surface; rather less than a fourth of the total length of the pubis free and projecting beyond the postero-inferior angle of the ischium, almost directly backwards. Anterior renal fossa deep, its length equal to the depth of the ischiadic foramen. Obturator foramen nearly closed by bone *Pelecanus.*
- d*. Pelvis about three times as long as broad; dorsal surface of postilium moderately broad.
- a'*. Ischiadic foramen nearly or quite five times the diameter of the acetabulum.
- a*². Preilium of about equal width throughout or with a very slight expansion cephalad; postilium presenting a moderately broad dorsal surface; about one-third of the total length of the pubis projecting beyond the postero-inferior angle of the ischium. Anterior renal fossa deep, moderately wide, length nearly or quite equal to the depth of the ischiadic foramen. Obturator foramen nearly or quite surrounded by bone..... *Sula.*
- b*². Preilium much expanded cephalad; about one-fourth total length of the pubis free, and turning downwards and inwards almost at a right angle at the postero-inferior angle of the ischium. Anterior renal fossa extremely narrow, length about equal to the depth of the ischiadic foramen. Obturator foramen not shut off from obturator fissure by bone *Phalacrocorax.*
- b'*. Ischiadic foramen about twice as long as acetabulum. Preilium much expanded cephalad; inferior border notched; dorsal surface of postilium with its outer border forming a thin raised edge to the dorsum of the pelvis; with a strong ridge from the post-trochanteric process forwards to meet its fellow in the middle line; about one-fourth of the total length of the pubis projecting beyond the postero-inferior angle of the ischium; anterior renal fossa small, pyriform. Obturator foramen nearly or quite shut off from the obturator fissure.
Plotus.

E. PECTORAL LIMB (figs. 5-7, p. 90).

A. All the bones of the wings pneumatic.

a. Ulna with a large pneumatic foramen lying on the palmar surface distad of the glenoid cavity.

a'. Humerus nearly as long as the ulna (in the articulated wing the arm is nearly as long as the forearm). Sub-trochanteric fossa large, continued cephalad under capitulum of humerus as a large pneumatic foramen, into which open numerous small foramina. Crista inferior (ulnar tuberosity) with anterior surface much inflated, and sharply defined from the shaft, distad, by a groove. Coraco-humeral groove a shallow depression. Pectoral crest (radial tuberosity) triangular, of moderate size. Insertion of brachialis anticus well-defined; with a pneumatic foramen above condylus ulnaris. Radius with a faint depression over the dorsal aspect of the expanded distal end. Manus having the carpo-metacarpus three times the length of Ph. 2. D. II. Ph. 1. D. II. with two deep and sharply defined postaxial depressions. Ph. 1. D. III. with a well-marked triangular postaxial border. *Pelecanus*.

b'. Humerus about one-fifth less than the ulna (in the articulated wing the arm is less than the forearm). Sub-trochanteric fossa not overhung by tuberculum inferius, otherwise resembling that of *Pelecanus*. Crista inferior inflated, but less sharply defined from the shaft. Coraco-humeral groove deep and narrow; triangular form of the radial tuberosity (pectoral crest) very large. Depression for brachialis anticus with a pneumatic foramen proximad of radial condyle. Radius with a deep depression over the superior border of the distal articular end. Manus having the carpo-metacarpus little more than twice length of Ph. 2. D. II. Postaxial ledge of Ph. 1. D. II. with two shallow depressions. Ph. 1. D. III. with the triangular postaxial border slightly developed *Fregata*.

b. Ulna with a very shallow depression in place of a pneumatic foramen. Humerus less than ulna (in the articulated wing the arm nearly equals forearm). Sub-trochanteric fossa overhung by tuberculum inferius, and running up as a pneumatic foramen into the caput humeri. Crista inferior flattened, passing gradually into the shaft. Coraco-humeral groove deep. Pectoral crest triangular, size moderate; depression for brachialis anticus not well-defined, without a pneumatic foramen. Manus having carpo-metacarpus less than twice length of Ph. 2. D. II.

..... *Phaëthon*.

c. Ulna with a distinct palmar and interglenoid pneumatic fossa. Humerus longer than ulna (in the articulated wing the arm is one-fifth longer than forearm). Sub-trochanteric fossa overhung by tuberculum inferius and running up as pneumatic foramen into caput humeri. Crista inferior slightly swollen, moderately defined from the shaft. Coraco-humeral groove shallow. Pectoral crest in the form of a long low ridge but little raised above the shaft. Depression for brachialis anticus well-defined and without a pneumatic foramen. Metacarpus nearly or quite as long as Ph. 2. D. II. *Sula*.

B. Wing-bones not pneumatic: pectoral crest a low ridge.

d. Crista inferior passing insensibly into shaft. Sub-trochanteric fossa deep, pneumatic foramen absent. Ulna equal or nearly equal in length to the humerus (in the articulated wing the arm shorter than forearm), with the border of the glenoid cavity for the radial condyle of the humerus produced into a hook-like process. Manus much shorter than ulna. Mc. III. very slightly arched; Ph. 1. D. II. with a deep ventral fossa.

..... *Phalacrocorax*.

e. Crista inferior with its free border arched, distinct from shaft, with a slight depression in place of the sub-trochanteric fossa. Ulna shorter than humerus (in articulated wing forearm shorter than arm); hook-like process of glenoid cavity of radial condyle of humerus but slightly developed. Manus equal, or nearly equal, to that of ulna. Mc. III. not arched; Ph. 1. D. II. with a shallow ventral depression. *Plotus*.

F. PELVIC LIMB.

- A. Fibula never more than three-fourths as long as the tibio-tarsus.
- a. Femur with a deep popliteal depression: tibio-tarsus with moderately well-developed ento- and ectocnemial crests. Fibular ridge well-marked, extending downwards to within a short distance of the middle of the shaft. Tarso-metatarsus with a large pneumatic foramen on the inner side of its proximal end; hypotarsus with a vertical ridge having a moderate backward extension, the free edge of which is expanded into a flattened surface; on the outer side of the ridge lie two closed canals: with a deep fossa above the insertion of the tibialis anticus leading into two large pneumatic foramina. Middle toe shorter than tarso-metatarsus *Pelecanus*.
 - b. Femur without a popliteal depression: tibio-tarsus with feebly developed ecto- and entocnemial crests. Fibular ridge absent. Tarso-metatarsus deeply grooved anteriorly, the groove leading directly into the foramen between the third and fourth trochleæ; gastrocnemial ridge feebly developed. Middle toe longer than the tarso-metatarsus ... *Phaethon*.
- B. Fibula extending downwards to the level of the external articular condyle of the tibio-tarsus.
- c. Femur with a fossa at the base of the great trochanter into which numerous pneumatic foramina open: tibio-tarsus with moderately developed ento- and ectocnemial crests. Fibular ridge well-marked. Tarso-metatarsus grooved anteriorly; with numerous pneumatic foramina immediately above the insertion of the tibialis anticus. Gastrocnemial ridge moderately well-developed *Sula*.
 - d. Femur without pneumatic foramina. Tarso-metatarsus slightly grooved anteriorly, with a deep fossa above the insertion of the tibialis anticus, at the bottom of which lie two foramina which pierce the shaft and emerge on either side of the gastrocnemial ridge. Fibular ridge very strong.
 - a'. Tibio-tarsus with strong ecto- and entocnemial crests, the latter reflected outwards. Gastrocnemial ridge very large, its free border expanded into a flattened surface. Tarso-metatarsus comparatively slender, length greater than that of the 2nd toe. Patella large, conical.
Phalacrocorax.
 - b'. Tibio-tarsus with the free edge of the entocnemial crest looking straight forward, not reflected outwards. Gastrocnemial crest moderately well-developed. Tarso-metatarsus short and broad, length less than that of the 2nd toe. Patella flattened, with a groove running obliquely across the middle for the tendon of the ambiens ... *Plotus*.
- C. Fibula fourth-fifths as long as tibio-tarsus. Femur nearly as long as fibula, very thick relatively to the tibio-tarsus, and highly pneumatic; with a popliteal fossa containing a pneumatic foramen. Tibio-tarsus non-pneumatic; cnemial crests feeble; fibular crest feeble. Tarso-metatarsus extremely short, resembling that of the Penguins, the three metatarsals being indicated by grooves; the length of the tarso-metatarsus one-third greater than the width measured across the trochleæ *Fregata*.

Phalacrocorax and *Sula* have each a free sternal rib attached to the posterior border of the last thoracic vertebra.

The vertebral column of *Pelecanus* is peculiar in that, of the thoracic vertebræ, only the 1st is free, the remainder being fused one with another and with the synsacrum. The transverse processes of the 2nd, 3rd, and 4th have ankylosed one with another, and the whole is fused with the anterior border of the preilium, so that, at first sight, it would appear as though this extended as

Tabular arrangement of the Vertebral Column: after Parker, Phil. Trans. 1891, p. 78 (see above, p. 87).

		S. sc.								
Cv. 16:	Cv. Th. 2:	Th. 3 + 2:	Lb. 4:	Lb. Sc. 3:	Sc. 2:	Cd. 8 + 8 = 48				<i>Phalacrocorax.</i>
		5				16				
		S. sc.								
Cv. 18:	Cv. Th. 2:	Th. 3 + 3:	Lb. 4:	Lb. Sc. 2:	Sc. 2:	Cd. 5 + 8 = 47				<i>Plotos.</i>
		6				13				
		S. sc.								
Cv. 17:	Cv. Th. 1:	Th. 4 + 2:	Lb. 4:	Lb. Sc. 2:	Sc. 2:	Cd. 4 + 9 = 45				<i>Sula.</i>
		6				13				
		S. sc.								
Cv. 16:	Cv. Th. 1:	Th. 1 + 3 + 1:	Lb. 3:	Lb. Sc. 4:	Sc. 2:	Cd. 4 + 7 = 42				<i>Pelecanus.</i>
		4				11				
		S. sc.								
Cv. 12:	Cv. Th. 2:	Th. 5 + 1:	Lb. 3:	Lb. Sc. 2:	Sc. 2:	Cd. 5 + 7 = 39				<i>Fregata.</i>
		6				12				
		S. sc.								
Cv. 11:	Cv. Th. 3:	Th. 6 + 1:	Lb. 2:	Lb. Sc. 2:	Sc. 2:	Cd. 3 + 9 = 39				<i>Phaethon.</i>
		7				12				

far forward as the 1st thoracic vertebra. The last sternal rib has a posterior expansion situated immediately behind the articulation with its dorsal element.

LIST OF WORKS REFERRED TO.

1. BEDDARD, F. E.—“On the Anatomy of *Phaëthon*.” P. Z. S. 1897.
2. BEDDARD, F. E.—“Note upon Intercentra in the Vertebral Column of Birds.” P. Z. S. 1897.
3. BRANDT, J. F.—“Beiträge zur Kenn. u. d. Naturgeschich. der Vögel.” Mém. Acad. Sci. St. Pétersbourg, sér. vi.
4. EYTON, T. C.—*Osteologia Avium*. London, 1867, pls. 5, 6, 7 L, pp. 216–220.
5. FORBES, W. A.—*Collected Scientific Papers*, pp. 216, 336.
6. FÜRBRINGER.—‘*Untersuch. zur Morphol. und Systemat. der Vögel.*’ II. Allgem. Theil. S. 1031.
7. GADOW, H.—*Bronn’s Thier-Reich*, Bd. vi., Vögel, 1891: Anatom. Theil.
8. GADOW, H.—*Ibid.*, Syst. Theil, 1893.
9. GARROD, H.—*Collected Scientific Papers*, 1881.
10. HUXLEY, T. H.—“On the Classification of Birds.” P. Z. S. 1867.
11. LYDEKKER, R.—*Cat. Foss. Birds Brit. Mus.*, 1891.
12. MIVART, St. G.—“On the Axial Skeleton of the Pelecanidæ.” *Trans. Z. S.* 1878.
13. SHUFELDT, R. W.—“Remarks on the Osteology of *Phalacrocorax bicristatus*.” *Science*, ii. p. 640.
14. SHUFELDT, R. W.—“Osteology of the Cormorant.” *Science*, iii. p. 143.
15. SHUFELDT, R. W.—“Observations on the Osteology of the Tubinares and Steganopodes.” *P. U. S. Nat. Mus.* 1888, p. 253.
16. WALKER, M. L.—“On the Form of the Quadrate Bone in Birds.” *Studies from the Museum of Zoology in University College, Dundee*, 1890, pp. 5–7, figs. 8, 9, 10.

EXPLANATION OF THE PLATES.

<i>B. pl.</i> = Basitemporal plate.	<i>Pt.</i> = Pterygoid.
<i>Mxp.</i> = Maxillo-palatine process.	<i>Q</i> = Quadrate.
<i>Ns.</i> = Nasal septum.	<i>V</i> = Vomer.
<i>P</i> = Palatine.	

PLATE VII.

- Fig. 1. Ventral view of the skull of *Fregata ariel*, showing the form of the basitemporal plate, the maxillo-palatine processes, and the ankylosis of the posterior ends of the palatines.
- Fig. 2. Ventral view of the skull of *Phaëthon flavirostris*, showing the same as fig. 1. The posterior ends of the palatines, though closely approximated, are not fused.
- Fig. 3. Ventral view of the skull of *Phalacrocorax carbo* showing the same as the above. The palatines are here more or less fused from the posterior narial aperture backwards to the pterygoids. There is no vomer.

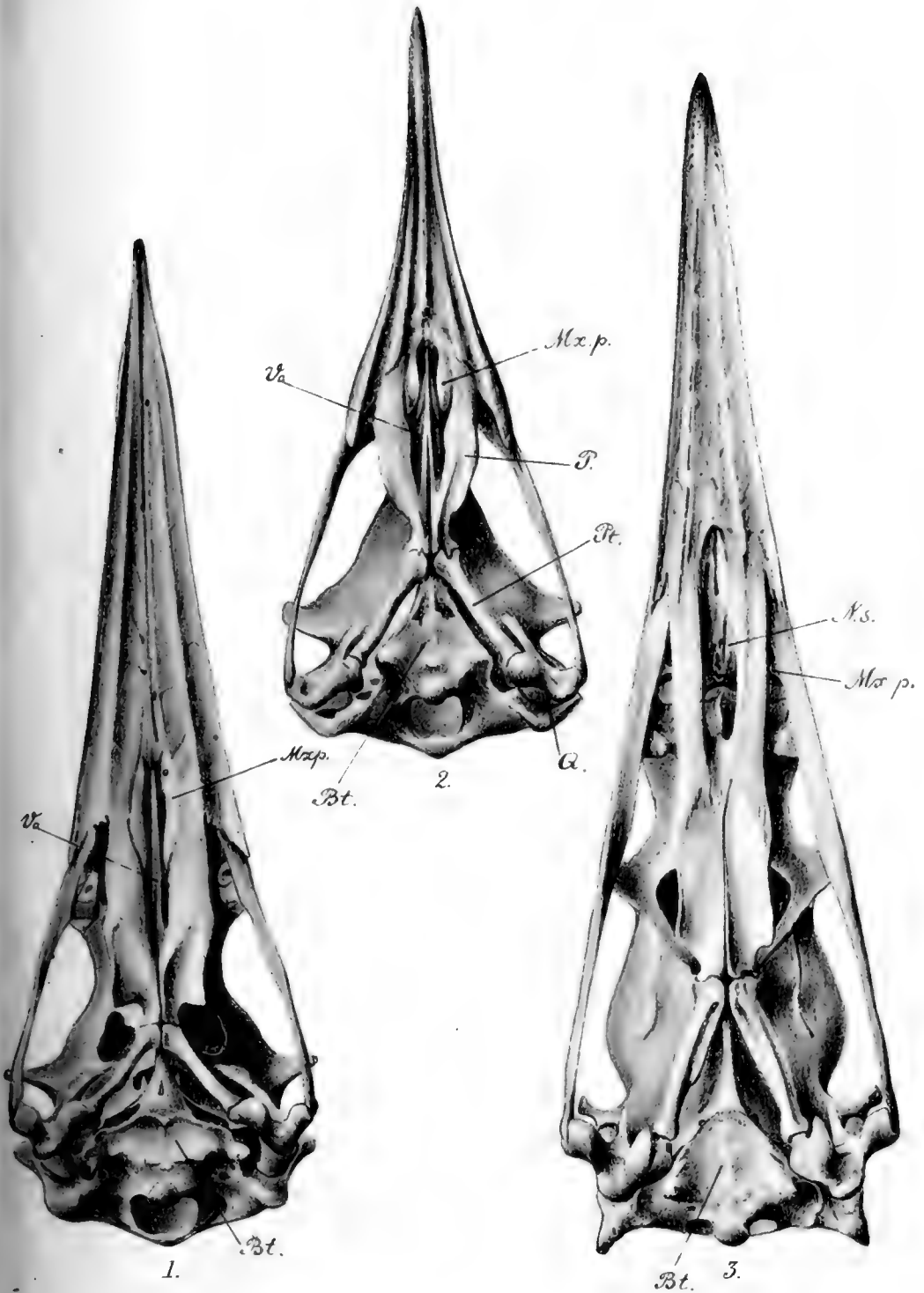

H. Grönvold del.

Photoprint by Bale, Danielsson Ltd

OSTEOLOGY OF STEGANOPODES.

- 1. *Fregata ariel.*
- 2. *Phaëthon flavirostris.*
- 3. *Phalacrocorax carbo.*





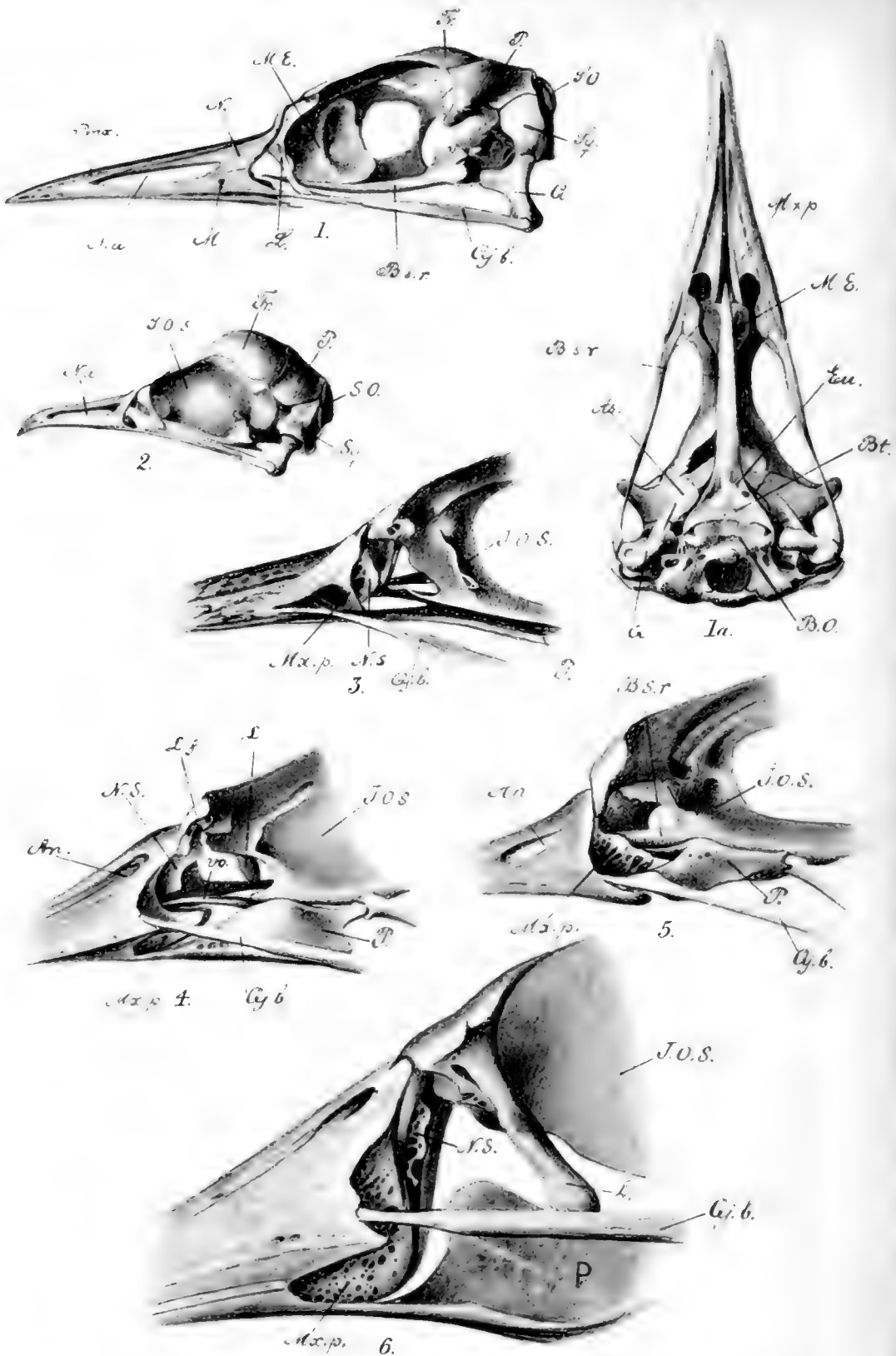

H. Grönvold del.

Photoprint by Bale, Danielsson L^{ta}

OSTEOLOGY OF STEGANOPODES.

1.1a & 5. *Phaëthon flavirostris*. 2. *Sula leucogastra*.

3. *Phalacrocorax carbo*. 4. *Fregata ariel*. 6. *Pelecanus rufescens*.

PLATE VIII.

- Fig. 1. Left side view of the skull of a nestling *Phaëthon flavirostris*, showing the sutures, the absence of a nasal hinge, and the large size of the anterior narial aperture. In order to expose the whole extent of the maxilla, the dentary border of the premaxilla has been removed.
- Fig. 1 a. Ventral view of the same skull. The pterygoids, palatines, and vomer have been removed, in order to show clearly the schizognathous nature of the palate.
- Fig. 2. Left side view of the skull of a very young nestling *Sula leucogastra*, showing the sutures and the large size of the anterior narial aperture.
- Fig. 3. Left side view of a portion of the cranio-facial region of the skull of *Phalacrocorax carbo*, to show the form of the maxillo-palatine processes and nasal septum when seen from behind. The lachrymal has been removed.
- Fig. 4. The same view of the skull of *Fregata ariel*.
- Fig. 5. The same view of the skull of *Phaëthon*. The maxillo-palatine processes are seen to have only a horizontal direction; there is no nasal septum.
- Fig. 6. The same view of the skull of *Pelecanus rufescens*. Note the great vertical height of the maxillo-palatine processes, and the vestigial *septum nasi*.

2. On the Skeleton of Regenerated Limbs of the Midwife-Toad (*Alytes obstetricans*). By W. G. RIDWOOD, D.Sc., F.L.S., F.Z.S.

[Received December 22, 1897.]

The capacity which the larvæ of the Anurous Batrachians possess of regenerating lost limbs or parts of limbs was made known to the world as long ago as 1769 by Spallanzani (12), and was verified by Günther¹ in 1866 (11. p. 567); and although the negative results obtained by Fraisse (6) in 1885 led this author to doubt the possibility of such regeneration, the original observation has recently received abundant confirmation at the hands of Barfurth (2) and Boulenger (4. p. 98). But whereas, as is well known, lost limbs can be developed anew at any period of life by certain Urodela, it is only in the larval stages of Anura that such phenomena are to be observed. Barfurth concludes from the results of his experiments that the capacity for reproducing lost parts diminishes in Anuran tadpoles as the development progresses, and on this hypothesis he explains the discrepancy between the results of Spallanzani and Fraisse.

With a view to following up the researches of Barfurth, Mr. G. A. Boulenger, F.R.S., seized the opportunity, when in Belgium in the spring of 1897, of procuring some fine full-grown tadpoles of the Midwife-Toad (*Alytes obstetricans*) and of repeating Barfurth's experiments upon them². These tadpoles had been spawned in

¹ A mistake has evidently occurred in Owen's transcription of Dr. Günther's manuscript. The statement "If a hind limb be cut off when the larva is about two lines long it is reproduced" is meaningless, because the larva of that size has no limbs. The words "two lines long" were evidently intended to apply to the size of the limb, not of the larva.

² Barfurth employed tadpoles of the common frog [*Rana fusca (temporaria)*].

the preceding summer, and might have been of the same brood. They were collected at Maurenne, near Hastière, in the province of Namur, in May 1897, and were all treated in exactly the same way, the left hind leg, then between seven and twelve millimetres in length, being amputated at the middle of the tibial segment and left to heal. Five of the specimens completed their metamorphosis, but the sixth became arrested in its development, and although kept under exactly the same conditions of life as the other five, failed to make any progress. All six were killed in October 1897, when Mr. Boulenger very kindly handed them over to me, together with the above information as to their previous history.

While, thanks to Götte (10), our knowledge of the normal and regenerated limb-skeleton of Urodela is not deficient, the skeleton of regenerated limbs of Anura does not appear to have hitherto received any attention; and it occurred to me that the best use to which the material entrusted to me could be put was the preparation and description of the regenerated cartilages. Bearing in mind the close similarity found by Götte to obtain between the regenerated and the normal limb-skeleton of Urodela, a somewhat similar correspondence was to be expected in Anura. But, having regard to the greater specialization of the Anuran limb, it was just possible that the restored skeleton might be simpler than the normal. On surveying the results of the investigation one cannot fail to be impressed by the closeness with which the skeletal parts of the newly-developed limb approach those of the normal.

While in animals other than Anura structural differences between the regenerated and the normal limb may be explained as phenomena of atavism [as claimed by Giard (7 and 8), Barfurth (1. p. 113 (6)), and Bordage (3)], there is no evidence of such phylogenetic reversion in the regenerated limb-skeleton of the Anura under consideration. The astragalus and calcaneum are elongated and are confluent with one another at both their proximal and distal extremities. The remaining tarsalia are disposed exactly as in the normal limb of the same age. Although in specimen C four of the five digits have each one phalanx less than the normal, there is abundant evidence in specimens A and B to show that the typical number of phalanges for each digit can be reproduced. And, lastly, the experiments throw no light whatever on the morphology of the calcar, although one might fully have expected atavism to be apparent here if anywhere.

Mr. Boulenger has also communicated to me the very interesting fact that, if the first appearance of the new limb be watched carefully, a single digit is first seen to grow out from the healed stump, then another digit at its side, then a third, and so on in succession. The tarsus and the distal half of the tibial segment of the leg appear to be intercalated afterwards between the digits and the stump. The chief interest of the successive appearance of the digits lies in the fact that this mode of development is characteristic of the Urodele limb. In the newts and salamanders,

as Götte (10) and Strasser (13) have shown, the first digit to develop is the second; the inner digit follows and then the remaining digits in succession, the third, the fourth, and, in the hind limb, the fifth. The digits of the normal Anuran limb, however, develop simultaneously, as Götte (9) has remarked in the case of *Rana* and *Hyla*, and as Dugès has figured in the case of *Pelobates* (5. pl. additionnelle, figs. 11-13). Four figures of the

Figs. 1-5.

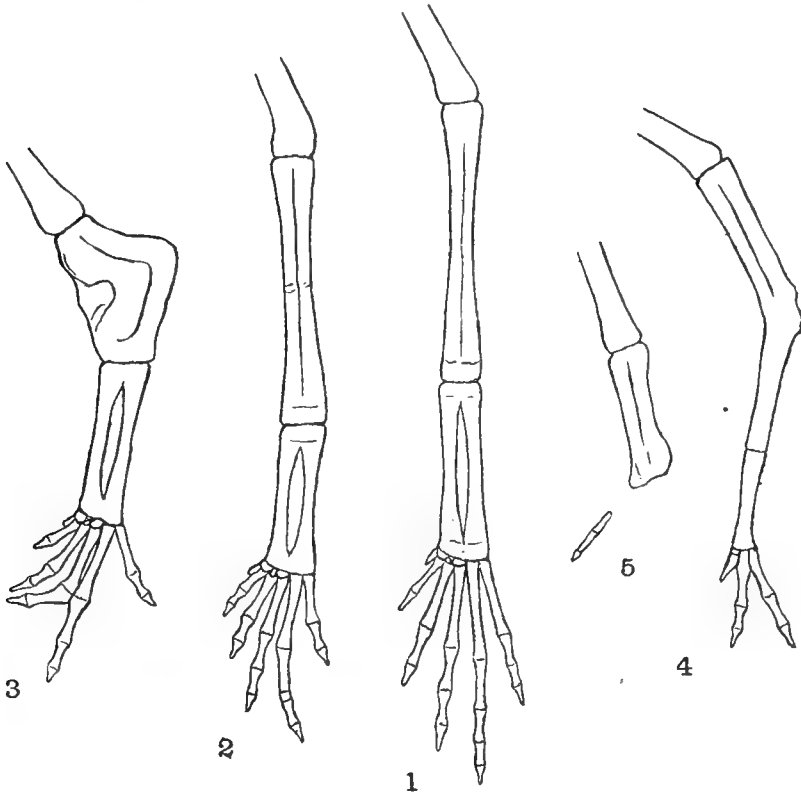
Skeleton of regenerated left hind limbs of *Alytes obstetricans* ($\times 5$).

budding normal limb of *Alytes* are here given (figs. 6-9, p. 104) to illustrate this point farther, and it will be noticed that, so soon as any digitation at all can be made out in the differentiating bud, all five digits can be counted. The explanation usually given for the exceptionally rapid development and the great length of the first-formed digits in the newts is that these are larval digits, of special functional importance to the larva. But in the Anuran tadpole the paired limbs are not used as a means of progression; they simply develop passively and slowly in anticipation of the approaching metamorphosis. It is curious, therefore, to find that in the regenerated limb of Anuran tadpoles the Urodele mode of digit-development should be adopted.

It not infrequently happens that the full complement of digits is not developed in the regenerated limb. Barfurth (2) has figured cases in which only one, two, three or four digits are present; and of the five¹ specimens now under consideration two possess only one and three digits respectively.

Figs. 6-9.

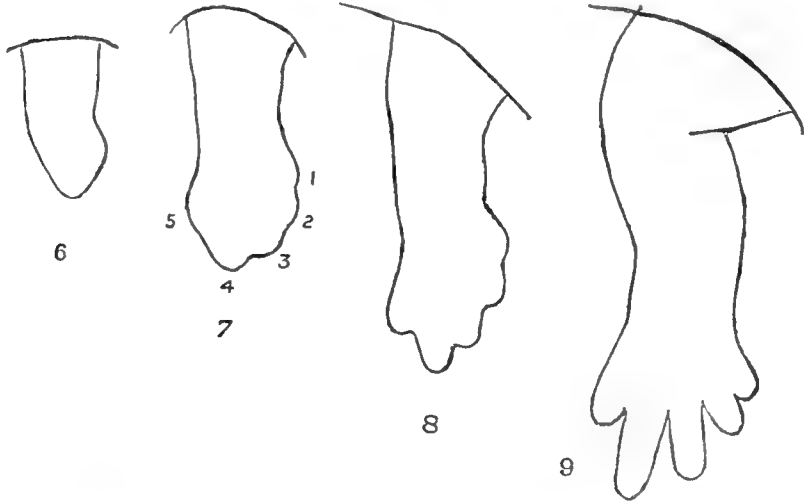

Outlines of developing hind limbs (normal) of *Alytes obstetricans* ($\times 10$).

SPECIMEN A. The regeneration in this case was most successful. The left leg resembled the right so exactly that, although the foot was slightly smaller and the toes a little shorter in proportion, the difference would pass without notice unless attention were specially directed to it. The colour-markings of the integument were identical in the two legs, and also the extent of the webbing of the foot. The skeleton of the leg (fig. 1, p. 103) is seen to be remarkably complete and in perfect keeping with the external characters of the limb. The only important feature in which this regenerated limb-skeleton differs from the normal is the presence of but one phalanx to the hallux and the slenderness of the hallux metatarsal. The remaining digits, the calcar, and the whole of the tarsus present no differences. The distal end of the tibio-fibula is in perfect continuity with the proximal portion, and there are no markings to indicate the limits of the secondary and primary portions of this bone.

SPECIMEN B. In this specimen the regenerated left leg was considerably shorter than the right or normal. The femoral joint was of the same size as in the right, but the remaining parts of

¹ That is, the five specimens which completed their metamorphosis. The development of the sixth appears to have been completely arrested, and the regenerated limb at the time of death had the form of a mere non-digitate bud, too small to allow of a macroscopic examination of the skeleton. This sixth specimen will, therefore, not be referred to again.

the limb were all dwarfed. The proportion of the web of the foot was normal, but the five toes were disproportionately short, so that the foot had a stunted appearance. In the skeleton (fig. 2, p. 103) the tarsus and metatarsus call for no remark except that the ratio between length and thickness is less than in the normal limb. The fifth digit has only two phalanges; and in the fourth digit, which suffers from an unnatural curve towards the postaxial side of the foot, the antepenultimate phalanx is short and nodular. The joint between the tibio-fibula and the proximal tarsals is not square, as it should be, but slightly oblique. Exactly halfway between the two extremities of the tibio-fibula is an irregular marking which delimits the regenerated distal half from the primary proximal half. The two halves are in perfect continuity, and the furrow between the tibia and fibula is also continuous.

SPECIMEN C (fig. 3). Even before preparing the skeleton of the regenerated leg it was evident that the second and third digits were syndactyle; and on removing the skin it became further apparent that the distal extremities of the third and fourth digits were immovably united. In the fully-prepared skeleton the second digit is seen to be the only one which possesses the normal number of phalanges, the remaining four being each one phalanx short. There is nothing remarkable about the tarsus, but the new distal part of the tibio-fibula is set at a sharp angle on the original proximal part. Moreover, the *original* part of the tibio-fibula has suffered distortion.

SPECIMEN D. This specimen is remarkable in that only the preaxial part of the limb has been regenerated (fig. 4). A distal continuation has been added to the tibia but not to the fibula, the astragalus is renewed but not the calcaneum, and of the five digits only the three preaxial ones are developed. Only one small tarsal of the distal row is present, and that belongs to the hallux. There is no calcar, and, although the second digit has its usual two phalanges, there are only two phalanges to the third digit, and none to the hallux.

SPECIMEN E. The regenerated parts in this specimen consist merely of a single digit, supported by three skeletal cartilages. No attempt has been made to complete the tibio-fibula, and there is no tarsus. There is an interval between the tibio-fibula and the skeleton of the digit (see fig. 5), and the axis of the latter makes an angle of about 55° with the tibio-fibula. This case appears to furnish a striking confirmation of the observation of Mr. Boulenger, communicated above, that in the regeneration of the limb the digits develop first, while the intermediate parts are intercalated afterwards, and also that the digits develop in succession and not simultaneously. It would seem that here, after the development of one digit, regeneration became arrested, so that we have in the young metamorphosed Batrachian the persistence of a very early phase of limb-regeneration.

LITERATURE CITED.

1. BARFURTH, D.—“ Die experimentelle Regeneration überschüssiger Gliedmassentheile (Polydaktylie) bei den Amphibien.” Archiv für Entwicklungsmechanik der Organismen (Roux), Bd. i., Leipzig, 1895, pp. 91–116. One plate.
2. BARFURTH, D.—“ Sind die Extremitäten der Frösche regenerationsfähig ? ” Arch. f. Entwicklungsmechanik d. Organ. (Roux), Bd. i., Leipzig, 1895, pp. 117–123. One plate.
3. BORDAGE, E.—“ On the Tetrameric Regeneration of the Tarsus in Phasmidæ.” Annals & Mag. Nat. Hist., vol. xx., London, 1897, pp. 507–510. (From the Comptes Rendus, t. cxxiv. 1897, pp. 1536–1538.)
4. BOULENGER, G. A.—The Tailless Batrachians of Europe. Part I. 8vo, London, 1897.
5. DUGÈS, A.—“ Recherches sur l’Ostéologie et la Myologie des Batraciens.” Mém. (des savans étrangers) de l’Acad. des Sci., t. vi., Paris, 1835, pp. 1–216.
6. FRAISSE, P.—Die Regeneration von Geweben und Organen bei den Wirbelthieren. Cassel und Berlin, 1885.
7. GIARD, A.—“ Polydaktylie provoquée chez *Pleurodeles waltii*.” Comptes Rendus de la Société de Biologie, t. ii. sér. x., Paris, 1895, pp. 789–792.
8. GIARD, A.—“ Sur les Régénérations hypotypiques.” C. R. de la Société de Biologie, t. iv. sér. x., Paris, 1897, pp. 315–317.
9. GÖTTE, A.—“ Zur Entwicklungsgeschichte des Gliedmassenskelets der Wirbelthiere.” Zool. Anzeiger, Jahrg. 1, Leipzig, 1878, p. 246.
10. GÖTTE, A.—Ueber Entwicklung und Regeneration des Gliedmassenskelets der Molche. 4to, Leipzig, 1879, 47 pages. Five plates.
11. OWEN, R.—Anatomy of Vertebrates, vol. i., London, 1866.
12. SPALLANZANI.—Physikalische und mathematische Abhandlungen. Leipzig, 1769.
13. STRASSER, H.—“ Zur Entwicklung der Extremitätenknorpel bei Salamandern und Tritonen.” Morph. Jahrb., Bd. v., Leipzig, 1879, pp. 240–315. Four plates.

3. Description of a new Sea-Snake from Borneo.

By G. A. BOULENGER, F.R.S.

[Received January 8, 1898.]

(Plate IX.)

HYDROPHIS FLOWERI, sp. nov. (Plate IX.)

Head very small; anterior part of body very slender, its diameter about one third the depth of the posterior part. Rostral broader than deep; frontal once and a half as long as broad, as long as its distance from the rostral, much shorter than the parietals; one præ- and one postocular; a single anterior temporal; six or seven upper labials, third and fourth entering the eye; two pairs of

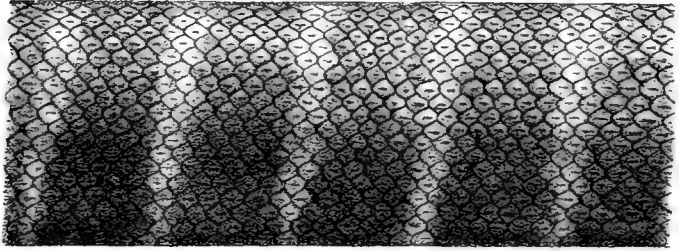



chin-shields, posterior separated by scales. Scales feebly imbricate, 27 round the neck, 37 round the body; scales nearly smooth on the neck, with a short tubercular keel on the body. Ventrals distinct throughout, 298-321. Dark olive or blackish; a crescentic yellow band from eye to eye across the snout, and a yellow band behind the eye; some small yellow markings on the crown; neck with yellow cross-bars, much narrower than the spaces between them; these bars gradually increase in extent on the body, but never completely encircle it; 69 yellow bars altogether on the body and tail.

Total length 900 millim.; tail 80.

This species, of which two specimens were obtained in Brunei Bay by Mr. S. S. Flower on the 3rd October, 1897, is nearest related to *Hydrophis mamillaris*, with which it agrees in form, scaling of the body, and coloration, but differs in the shorter frontal and the presence of a single postocular and a single anterior temporal. From *H. fasciatus* it differs in the lower number of scales round the body and the presence of scales between the posterior chin-shields, as well as in the coloration.

The larger of the two specimens (which is figured, Plate IX.) presents these anomalies, that the nasal shields are fused in their anterior half, and that a small additional chin-shield has arisen through division of the first left lower labial.

4. An Account of the Reptiles and Batrachians collected by Mr. W. F. H. Rosenberg in Western Ecuador. By G. A. BOULENGER, F.R.S.

[Received February 1, 1898.]

(Plates X.-XVIII.)

The collection made by Mr. Rosenberg in Ecuador, of which a complete set will be acquired for the British Museum, adds considerably to our knowledge of this herpetologically so fertile district, and to the long list of species with which we are acquainted through the previous explorations of Fraser, Orton, Espada, De Ville, Buckley, Whymper, and Festa. Twenty-three new species are described in this paper.

The localities whence the specimens were obtained are:—Cachabé, Paramba, Ibarra, Cayamba, and Chimbo.

Mr. Rosenberg has kindly furnished me with the following information respecting these places:—

1. *Cachabé*, a small village on the river of that name, on the N.W. Coast, in the Prov. Esmeraldas. Owing to an accident to the barometer, the exact altitude of the village could not be ascertained, but it is probably about 500 feet above the sea. It is surrounded by dense forest.

2. *Paramba*, a farm on the W. bank of the River Mira, at 3500 feet altitude; it is still in the forest region, but the open country commences two or three miles higher up the Mira.

3. *Ibarra*, a city two days' ride from Paramba and about the same distance from Quito; altitude about 6600 feet. The country is for the most part cultivated.

4. *Cayamba*, a small town N.E. and about a day and a half's ride from Quito; altitude 9323 feet (Whymper).

5. *Puente del Chimbo*, the railway terminus about 70 miles from Guayaquil, at an elevation of about 1000 feet. Much of the surrounding country is thick forest, but the district is more extensively cultivated than is the case on the N.W. Coast.

REPTILIA.

CHELONIA.

CINOSTERNIDÆ.

1. CINOSTERNUM LEUCOSTOMUM, A. Dum.

In describing Mr. Whymper's collection in 1882, I alluded to two very young, dried specimens from Nanegal, 3000 feet, which established for the first time the occurrence of the genus *Cinosternum* south of Colombia, and I compared them to *C. leucostomum*, to which, however, owing to their condition, I did not venture to refer them. The fact that Mr. Rosenberg's collection includes an adult specimen from Chimbo which undoubtedly belongs to *C. leucostomum* removes all doubt from my mind that Mr. Whymper's specimens were likewise referable to that species.

TESTUDINIDÆ.

2. NICORIA ANNULATA, Gray.

Paramba.

LACERTILIA.

EUBLEPHARIDÆ.

3. LEPIDOBLEPHARIS FESTÆ, Peracca.

The highly interesting discovery of an Eublepharid in Ecuador was made known by Count Peracca only a few months ago (Boll. Mus. Torino, xii. 1897, no. 300). The specimen from Chimbo contained in the present collection agrees entirely with that author's excellent description, but is of larger size, measuring 45 millim. from snout to vent; tail (reproduced) 41 millim.

IGUANIDÆ.

4. ANOLIS PERACCÆ, sp. n. (Plate X. fig. 1.)

Head nearly twice as long as broad, longer than the tibia; forehead concave; frontal ridges short and feeble; upper head-scales keeled; scales of the supraorbital semicircles enlarged, separated by one or two series of scales; keeled enlarged supra-ocular scales in contact with the supraorbitals; occipital as large as or a little smaller than the ear-opening, separated from the

supraorbitals by three or four rows of scales; canthus rostralis angular, canthal scales three or four; loreal rows five or six; six or seven upper labials to below the centre of the eye; ear-opening rather large, oval. Gular appendage large, merely indicated in the female; gular scales smooth. Body feebly compressed; no dorso-nuchal fold. Dorsal scales very small, granular, keeled, a little larger than the granules on the flanks; ventral scales larger than dorsals, juxtaposed, smooth. The adpressed hind limb reaches the eye on the posterior border of the orbit; digits rather feebly dilated; 17 or 18 lamellæ under phalanges ii. and iii. of the fourth toe. Tail roundish, covered with strongly keeled scales without enlarged dorsal series; length of tail about twice that of head and body. Male with enlarged postanal scales. Greyish or reddish brown above, speckled or marbled with darker, and with dark brown chevron-shaped bars, pointing forwards, across the back; tail with very regular dark annuli; greyish or whitish beneath, uniform or marbled or reticulated with blackish on the sides; throat dotted with blackish; gular appendage yellow.

	♂.	♀.
	millim.	millim.
Total length	148	183
Head	15	16
Width of head	7.5	8
Body	35	47
Fore limb	23	28
Hind limb	37	49
Tibia	11	14
Tail	98	120

This species comes nearest to *A. fusco-auratus*, D'Orb. I have named it after my friend Count M. Peracca, who has recently described some highly interesting additions to the herpetology of Ecuador.

Six specimens from Chimbo.

5. *ANOLIS ELEGANS*, sp. n. (Plate X. fig. 2.)

Head twice as long as broad, as long as the tibia; forehead concave; frontal ridges short and feeble; upper head-scales feebly keeled; scales of the supraorbital semicircles large, separated by a single series of small scales on the vertex; 11 or 12 enlarged, keeled supraocular scales, separated from the supraorbitals by one series of granules; occipital not quite so large as the ear-opening, separated from the supraorbitals by three series of scales; canthus rostralis angular, canthal scales three; loreal rows five; six upper labials to below the centre of the eye; ear-opening moderately large, roundish. Gular appendage very large; gular scales smooth. Body compressed; no dorso-nuchal fold. Dorsal scales very small, granular, scarcely larger than the laterals; ventrals larger, small, granular, smooth. The adpressed hind limb reaches the eye; digits moderately dilated; 22 lamellæ under phalanges ii. and iii. of the fourth toe. Tail feebly compressed, covered with

strongly keeled scales without enlarged dorsal series; length of tail twice and a half that of head and body. Feebly enlarged postanal scales. Purplish brown above, with seven bluish-grey cross-bands on the nape and back, the anterior angular and pointing forwards; sides with round light spots between the cross-bands; tail dark brown in its basal fourth, then annulate dark brown and whitish, and whitish in its terminal half; lower parts greyish; gular appendage white.

	millim.
Total length	230
Head	16
Width of head	8
Body	50
Fore limb	30
Hind limb	53
Tibia	16
Tail	164

This species may be regarded as intermediate between *A. buckleyi*, O'Sh., and *A. fasciatus*, Blgr., both of which are likewise natives of Ecuador.

A single male specimen from Chimbo.

6. *ANOLIS CHLORIS*, sp. n. (Plate X. fig. 3.)

Head once and three fourths as long as broad, a little longer than the tibia; forehead concave; no frontal ridges; upper head-scales small, smooth; scales of the supraorbital semicircles feebly enlarged, separated by two series of scales; supraocular scales small, the larger ones feebly keeled; occipital scarcely enlarged; canthus rostralis angular, canthal scales five; loreal rows five; six upper labials to below the centre of the eye; ear-opening rather small, oval. Gular appendage large; gular scales small. Body scarcely compressed; no dorso-nuchal fold. Scales on the back and sides minute, granular; ventral larger, but very small, granular, smooth. The adpressed hind limb reaches the eye; digital expansions moderate; 18 lamellæ under phalanges ii. and iii. of the fourth toe. Tail rounded, covered with keeled scales, without enlarged dorsal series; length of tail a little over twice that of head and body. Male with enlarged postanal scales. Uniform green above, white below; a few black dots on the lower surface of the thighs.

	millim.
Total length	138
Head	13
Width of head	7.5
Body	31
Fore limb	21
Hind limb	36
Tibia	11
Tail	94

Allied to the preceding.

A single male specimen from Paramba.

7. *ANOLIS MACULIVENTRIS*, sp. n. (Plate XI. fig. 1.)

Head twice as long as broad, a little longer than the tibia; forehead concave; frontal ridges short, feeble; upper head-scales small, keeled; scales of the supraorbital semicircles moderately enlarged, separated by three or four series of small scales; a few feebly enlarged, keeled supraocular scales, separated from the supraorbitals by a series of granules; occipital scale slightly enlarged; canthus rostralis angular, canthal scales four or five; loreal rows eight; eight labials to below the centre of the eye; ear-opening moderately large, oval. Gular appendage rather large, merely indicated in the female; gular scales smooth. Body feebly compressed; no dorso-nuchal fold. Dorsal and lateral scales minute, granular; ventrals larger, but very small, granular, smooth. The adpressed hind limb reaches the eye; digits rather feebly dilated; 16 lamellæ under phalanges ii. and iii. of the fourth toe. Tail roundish, covered with keeled scales, without enlarged dorsal series; length of tail not quite twice that of head and body. No enlarged postanal scales. Brownish or purplish grey above, with metallic lustre; a dark cross-bar between the eyes and a dark spot on the occiput; limbs with rather indistinct dark cross-bars; tail with dark annuli; whitish beneath, much spotted or marbled with dark brown; gular appendage red.

	♂. millim.	♀. millim.
Total length.....	126	107 (tail imperfect).
Head	12	14
Width of head.....	6	7
Body.....	33	36
Fore limb.....	18	20
Hind limb	33	39
Tibia.....	11	12
Tail	81	—

Allied to *A. gemmosus*, O'Sh.
Two specimens from Paramba.

8. *ANOLIS COPII*, Bocourt.

Paramba.

9. *ANOLIS GRANULICEPS*, sp. n. (Plate XI. fig. 2.)

Head once and two thirds to once and three fourths as long as broad, as long as, or slightly shorter than the tibia; forehead concave; frontal ridges feeble, short; upper head-scales very small, almost granular, keeled; scales of the supraorbital semicircles moderately enlarged, separated by three to five series of scales on the vertex; feebly enlarged, strongly keeled supraocular scales; occipital a little smaller than the ear-opening, separated from the supraorbitals by four or five series of scales; canthus rostralis angular; canthal scales three or four; loreal rows seven or eight; eight or nine upper labials to below the centre of the eye; ear-opening large, oval. Gular appendage very small, merely indicated

in the female; gular scales granular, smooth. Body feebly compressed; no dorso-nuchal fold. Dorsal scales very small, granular, a little larger than the lateral scales; ventral scales larger than dorsals, small, juxtaposed, keeled. The adpressed hind limb reaches the eye or the tip of the snout; digits feebly dilated; 15 or 16 lamellæ under phalanges ii. and iii. of the fourth toe. Tail roundish, covered with strongly keeled scales, without enlarged dorsal series; length of tail once and two thirds to twice that of head and body. Male without enlarged postanal scales. Brown or olive above, uniform or with small darker spots; a more or less distinct dark lateral band from the eye to the side of the body, passing through the upper half of the ear-opening; this band often bordered below by a whitish streak, which may extend to the hind limb; lower parts whitish, uniform or much speckled with brown.

	♂.	♀.
	millim.	millim.
Total length.....	117	108
Head	12	11
Width of head.....	7	6
Body.....	30	30
Fore limb.....	20	19
Hind limb	37	36
Tibia.....	12	11
Tail	75	67

Allied to *A. stigmatosus*, Bocourt.

Several specimens from Paramba.

10. ANOLIS GRACILIPES, sp. n. (Plate XI. fig. 3.)

Head once and three fourths to twice as long as broad, as long as or slightly shorter than the tibia; forehead concave; frontal ridges distinct, short; upper head-scales keeled; scales of the supraorbital semicircles strongly enlarged, in contact with each other on the vertex or separated by one series of scales; a few strongly enlarged, keeled supraocular scales; occipital a little larger than the ear-opening, separated from the supraorbitals by one or two rows of scales; canthus rostralis angular; canthal scales four or five; loreal rows seven or eight; ten to twelve upper labials to below the centre of the eye; ear-opening moderately large, oval. Gular appendage large, merely indicated in the female; gular scales keeled. Body compressed; no dorso-nuchal fold. Dorsal scales small, rhomboidal, subimbricate, strongly keeled; lateral scales minute, granular; ventral scales larger than dorsals, rhomboidal, subimbricate, strongly keeled. The adpressed hind limb reaches the tip of the snout, or between the eye and the tip of the snout; digits feebly dilated; 14 lamellæ under phalanges ii. and iii. of the fourth toe. Tail roundish, covered with strongly keeled scales, without enlarged dorsal series; length of tail about twice that of head and body. Male without enlarged postanal scales. Greyish or pale bronzy olive above, with symmetrical dark

brown or reddish-brown markings, in the form of symmetrical designs on the upper surface of the head, a broad wavy band on the temple, above the ear, two series of large spots on the back connected across the vertebral region by angular cross-bars, and narrow bars across the limbs; upper lip white below the eye, with large dark spots; whitish beneath; gular appendage yellow.

	♂. millim.	♀. millim.
Total length	172	? ¹
Head	15	14
Width of head	8	8
Body	40	40
Fore limb	27	24
Hind limb	50	45
Tibia	16	15
Tail	117	?

Distinguished from the preceding by the larger ear-opening and the much smaller dorsal and ventral scales.

Four specimens from Paramba.

11. ANOLIS BIPORCATUS Wiegman.

Paramba.

12. ANOLIS LEMNISCATUS, sp. n. (Plate X. fig. 4.)

Head twice as long as broad, as long as the tibia; forehead concave; frontal ridges short and feeble; upper head-scales keeled; scales of supraorbital semicircles enlarged, separated by one or two series of scales; 5 to 8 enlarged, strongly keeled supra-ocular scales, separated from the supraorbitals by one series of granules; occipital larger than the ear-opening, separated from the supraorbitals by two or three series of scales; canthus rostralis angular, canthal scales three or four; loreal rows six; eight to ten upper labials to below the centre of the eye; ear-opening moderately large, roundish. Gular appendage large, absent in the female; gular scales keeled. Body compressed; no dorso-nuchal fold. Dorsal scales rather large, hexagonal, subimbricate, strongly keeled, forming 11 or 12 longitudinal series; lateral scales minute, granular; ventral scales larger than dorsals, hexagonal, subimbricate, strongly keeled. The adpressed hind limb reaches the eye or between the eye and the tip of the snout; digits feebly dilated; 14 or 15 lamellæ under phalanges ii. and iii. of the fourth toe. Tail slightly compressed, covered with strongly keeled scales without enlarged dorsal series; length of tail a little more than twice that of head and body. Male without enlarged postanal scales. Pale greyish or bronzy above, with elegant symmetrical dark brown markings; a V-shaped band on the snout, pointing backwards; a cross-band from eye to eye; a band behind the eye, passing above the tympanum; a series of large spots or oblique bars on the sides of the body connected by

¹ Tail injured.

V-shaped bars across the spine; regular cross-bars on the limbs and annuli on the tail; a white band from below the eye to the side of the body, passing through the ear; a dark brown vertical bar below the eye; whitish beneath; gular appendage yellow.

	♂.	♀.
	millim.	millim.
Total length.....	167	137
Head	15	13
Width of head.....	7.5	7
Body.....	37	32
Fore limb.....	23	20
Hind limb	46	39
Tibia.....	14	12
Tail	115	92

Allied to *A. cupreus* Hallow. and *A. rhombifer* Blgr.
Several specimens from Chimbo.

13. POLYCHRUS GUTTUROSUS Berth.

Paramba.

14. BASILISCUS GALERITUS A. Dum.

Paramba and Chimbo.

15. ENYALIOIDES FESTÆ Peracca.

Paramba.

16. LIOCEPHALUS GUENTHERI Blgr.

Ibarra and between Cachabé and Paramba.

TEIIDÆ.

17. AMEIVA BRIDGESII Cope.

Paramba.

18. AMEIVA SEPTEMLINEATA A. Dum.

Chimbo.

19. ECHINOSAUBA HORRIDA Blgr.

Paramba.

20. PHOLIDOBOLUS MONTIUM Ptrs.

Ibarra and between Cachabé and Paramba.

21. PROCTOPORUS UNICOLOR Gray.

Chimbo and between Cachabé and Paramba.

AMPHISBÆNIDÆ.

22. AMPHISBÆNA FULIGINOSA L.

Paramba.

OPHIDIA.

BOIDÆ.

23. TRACHYBOA GULARIS Ptrs.

A single specimen, 155 millim. long, from Paramba.

It agrees with Peters's description and Jan's figure, except in having the eye completely surrounded with 14 scales, labials being excluded. Scales 29; ventrals 142; subcaudals 27.

COLUBRIDÆ.

24. SYNOPHIS MIOPS, sp. n. (Plate XII. fig. 1.)

Eye small, one third the length of the snout. Rostral much broader than deep, scarcely visible from above; nasal divided internasals very small, a little broader than long; præfrontal very large, covering nearly the whole upper surface of the snout, descending to the upper labials; frontal as long as broad, as long as the præfrontal, much shorter than the parietals; supraocular small; no loreal; one large præocular, forming a suture with the frontal; one postocular; temporals 1+2; eight upper labials, fourth and fifth entering the eye; four lower labials in contact with the anterior chin-shields, which are shorter than the posterior. Scales striated and strongly keeled, in 19 rows. Ventrals 138; anal entire; subcaudals 91. Black above, the occiput and part of the temple yellow; belly yellowish white; lower surface of tail greyish.

Total length 390 millim.; tail 135.

A single female specimen from Paramba.

Distinguished from *Synophis bicolor* Peracca (Boll. Mus. Torin. xi. 1896, no. 266), by the smaller eye, the absence of the loreal shield, the division of the nasal, the presence of a single postocular, and the lower number of ventral and subcaudal shields.

25. DRYMOBIUS BODDAERTII Sentz.

Paramba.

26. DRYMOBIUS RHOMBIFER Gthr.

Paramba.

27. DRYMOBIUS DENDROPHIS Schleg.

Paramba.

28. SPILOTES MEGALOLEPIS Gthr.

A single male specimen from Paramba, with 217 ventrals and 122 subcaudals. The exact habitat of this snake was still unknown.

29. HERPETODRYAS CARINATUS L.

Paramba.

30. HERPETODRYAS FUSCUS L.

Paramba and Chimbo.

31. HERPETODRYAS GRANDISQUAMIS Ptrs.

Paramba.

This snake was only known from Costa Rica.

32. LEPTOPHIS BOCOURTI, sp. n.

Leptophis liocercus (non Wied), Bocourt, Miss. Sc. Mex., Rept. p. 823, pl. lxii. fig. 3 (1895).

Rostral much broader than deep, just visible from above; internasals shorter than the præfrontals; frontal once and one third as long as broad, as long as its distance from the rostral or the end of the snout, as long as or a little shorter than the parietals; nasal elongate, divided; no loreal; præfrontal in contact with labials; one præocular, in contact with or narrowly separated from the frontal; two postoculars; temporals 1+2; nine upper labials, fifth and sixth entering the eye; five or six lower labials in contact with the anterior chin-shields, which are shorter than the posterior. Scales in 15 rows, all except the outer row strongly keeled; scales on the neck and tail keeled. Ventrals feebly angulate laterally, 159-168; anal divided; subcaudals 165-172. Bright green above, closely speckled all over with black; the keels on the scales black; a black streak behind the eye; upper lip and lower parts pale green.

Total length 1600 millim.; tail 620.

Two specimens from Paramba and one from Cachabé.

The specimen described by Bocourt is from Peru.

33. LIOPHIS ALBIVENTRIS Jan.

Ibarra and Paramba.

34. XENODON COLUBRINUS Gthr.

Paramba.

35. PETALOGNATHUS NEBULATA D. & B.

Paramba.

36. ATRACTUS MULTICINCTUS Jan.

Paramba.

The specimens belong to the form figured by Jan as *Rabdosoma badium*, var. *multicinctum*. I think they deserve specific distinction from *A. badius*, as first suggested to me by my friend Count Peracca, owing to the higher number of ventral shields (177-182) and the shape of the rostral, which is as deep as broad. No spots whatever on the belly.

37. HIMANTODES CENCHOA L.

Paramba.

38. *LEPTODIRA ANNULATA* L.

Paramba.

39. *OXYBELIS BREVIROSTRIS* Cope.

Paramba and Cachabé.

40. *OXYBELIS ACUMINATUS* Wied.

Paramba.

41. *ERYTHROLAMPRUS ESCULAPII* L.

Paramba.

42. *HOMALOCRANIUM MELANOCEPHALUM* L.

Ibarra.

43. *ELAPS CORALLINUS* Wied.

Paramba.

44. *ELAPS ROSENBERGI*, sp. n. (Plate XIII.)

Eye very small, measuring two fifths its distance from the mouth. Rostral much broader than deep, just visible from above; frontal once and a half as broad as the supraocular, once and a half as long as broad, as long as its distance from the rostral, shorter than the parietals; latter longer than their distance from the internasals; one præ- and two postoculars; temporals 1+1; seven upper labials, third much larger than fourth, third and fourth entering the eye; four lower labials in contact with the anterior chin-shields, the first forming a suture with its fellow behind the symphyisial; posterior chin-shields longer than the anterior. Scales in 15 rows. Ventrals 288; anal divided; sub-caudals 30. Above with 20 black areas separated by narrow red ones spotted with black; below, each black area breaks up into three, separated by white interspaces of nearly equal width, viz., occupying two or three ventral shields; head, as far back as the middle of the parietal, white spotted with black; end of snout and frontal shield black; occiput and nape black, the first white cross-band ascending on each side to the second temporal.

Total length 1510 millim.; tail 85.

A single female specimen from Paramba.

45. *ELAPS ANCORALIS* Jan.

A single specimen from Chimbo, with 260 ventrals and 32 sub-caudals.

AMBLYCEPHALIDÆ.

46. *LEPTOGNATHUS ELLIPSIFERA*, sp. n. (Plate XII. fig. 2.)

Body strongly compressed. Eye moderate. Rostral broader than deep, scarcely visible from above; internasals half as long as the præfrontals; frontal as long as broad, as long as its distance from the end of the snout, shorter than the parietals; nasal entire

or semidivided; loreal twice or twice and one third as long as deep, bordering the eye; a small præocular usually present between the loreal and the supraocular; two postoculars, rarely one; temporals 2+2 or 3; seven upper labials, fourth or fourth and fifth entering the eye; first lower labial in contact with its fellow behind the symphysial; three or four pairs of chin-shields, anterior as long as broad. Scales in 15 rows, vertebrals strongly enlarged, the largest twice as broad as long. Ventrals 148-160; anal entire; subcaudals 60-76. Olive-brown above, regularly marked with black ellipses with lighter centres disposed vertically on each side of the body, the two series alternating; head spotted or marbled with black; lower parts whitish, speckled and largely spotted with black.

Total length 645 millim.; tail 145.

Several specimens from Ibarra.

VIPERIDÆ.

47. *LACHESIS ATROX* L.

Paramba and Chimbo.

48. *LACHESIS LANSBERGII* Schleg.

Paramba.

49. *LACHESIS SCHLEGELII* Berth.

Chimbo.

BATRACHIA.

ECAUDATA.

RANIDÆ.

1. *PHYLLOBATES INFRAGUTTATUS*, sp. n. (Plate XIV. fig. 1.)

Snout rounded, moderately prominent, as long as the diameter of the orbit; loreal region vertical; nostril slightly nearer the tip of the snout than the eye; interorbital space a little broader than the upper eyelid; tympanum distinct, close to the eye and three fifths its diameter. Fingers moderate, first not extending beyond second; toes moderate, free; disks well developed, smaller than the tympanum; two small metatarsal tubercles, inner oval, outer rounded; a short, curved, tarsal fold. The tibio-tarsal articulation reaches the eye. Skin perfectly smooth. Blackish brown above, with a more or less distinct lighter greyish streak on each side from eye to groin, another on each side of the snout along the loreal region, and a third along the back of the thigh; throat and belly blackish brown with round white spots.

From snout to vent 23 millim.

Two specimens from Chimbo.

2. *PROSTHERAPIS FEMORALIS* Blgr.

Paramba and Cachabé.

3. *COLOSTETHUS LATINASUS* Cope.

Chimbo.

4. *PHYLLODROMUS PULCHELLUS* Espada.

Cachabé.

DENDROBATIDÆ.

5. *DENDROBATES TINCTORIUS* Schm.

Cachabé.

ENGYSTOMATIDÆ.

6. *ATELOPUS IGNESEENS* Cornalia.

Cayamba, Sibambé, Ibarra.

7. *ATELOPUS CRUCIGER* Mart.

Cachabé.

8. *ATELOPUS ELEGANS* Blgr.

Cachabé.

This species, known from a single specimen obtained at Tanti (2000 feet) by Mr. Whymper, varies much in the colour and markings, as shown by the numerous specimens collected by Mr. Rosenberg. The black lateral streak is constant, but the dorsal markings may be in the form of spots, vermiculate lines, or four regular longitudinal streaks; the ground-colour of the upper parts is brown, grey, pale greenish, or lemon-yellow. The largest specimen, a female full of spawn, measures only 37 millim. from snout to vent.

CYSTIGNATHIDÆ.

9. *HYLODES ANOMALUS*, sp. n. (Plate XIV. fig. 2.)

Tongue oval, entire or indistinctly emarginate behind. Vomerine teeth in two strong, transverse, slightly curved and slightly oblique series behind the choanæ, on a level with the palatine bones. Head rather large, a little broader than long; snout rounded, as long as the diameter of the orbit; canthus rostralis distinct; loreal region very oblique, concave; nostril a little nearer the tip of the snout than the eye; interorbital space much narrower than the upper eyelid; tympanum distinct, one third to two fifths the diameter of the eye. Fingers rather short, first longer than second, the tips merely swollen; toes moderate, one half or two thirds webbed, ending in well-developed disks, which are broader than long; subarticular tubercles feeble; an elongate inner metatarsal tubercle, measuring about two-thirds the length of the inner toe; a small, round, outer metatarsal tubercle. The tibio-tarsal articulation reaches between the eye and the tip of the snout. Skin rugose above with small warts and glandular ridges, the strongest of which are behind the eyes; lower parts smooth; a well-marked ventral disk. Olive above, mottled and marbled with darker;

upper lip with dark bars; limbs with rather ill-defined dark cross-bars; hinder side of thighs blackish, spotted or marbled with yellow; lower parts white, throat brown or mottled with brown. Male without vocal sac.

From snout to vent 59 millim.

Three specimens from Cachabé.

This species differs so much from the other members of the genus *Hylodes* in the extensive web between the toes that it might be made the type of a new genus. I am, however, unwilling to adopt such a course at present, in view of the existence of the species *H. palmatus* and *H. raniformis*, which afford a link between this and the more typical forms, and render the character of the development of the web between the toes one of very doubtful value in this group; a conclusion which is further strengthened by a study of several other genera of Tailless Batrachians.

10. *HYLODES CONSPICILLATUS* Gthr.

Paramba and Chimbo.

11. *HYLODES LONGIROSTRIS*, sp. n. (Plate XV. fig. 1.)

Tongue oval, slightly nicked behind. Vomerine teeth in two strong transverse series close together behind the choanæ, on a level with the palatine bones. Head longer than broad; snout obtusely acuminate, much longer than the diameter of the orbit; canthus rostralis strong; loreal region moderately oblique, concave; nostril much nearer the tip of the snout than the eye; interorbital space as broad as the upper eyelid; tympanum very distinct, half the diameter of the eye. Fingers moderate, first extending as far as second; toes moderate, one third webbed; tips of fingers and toes dilated into well-developed disks, which are a little broader than long, and measure about one third the diameter of the eye; subarticular tubercles strong; a small oval inner and a rounded outer metatarsal tubercle. The tibio-tarsal articulation reaches a little beyond the tip of the snout. Skin smooth above and below, or with a few very small warts on the head and back; a strong fold above the tympanum; a well-marked ventral disk. Grey-brown or pinkish above, with a dark cross-band between the eyes, and a more or less distinct dark hourglass-shaped marking on the back; a black canthal and temporal streak; limbs with regular dark cross-bars; hinder side of thighs uniform brown; white beneath, with a few dark brown spots on the throat and breast. Male with an internal vocal sac.

From snout to vent 50 millim.

Several specimens from Cachabé.

12. *HYLODES ACHATINUS*, sp. n. (Plate XV. fig. 2.)

Tongue oval, slightly nicked behind. Vomerine teeth in two short oblique series behind the choanæ. Head moderate, as long as broad; snout rounded, as long as the diameter of the orbit; canthus rostralis distinct; loreal region oblique, concave; nostril

much nearer the tip of the snout than the eye; interorbital space as broad as the upper eyelid; tympanum distinct, half the diameter of the eye. Fingers moderate, first longer than second; toes free; disks small; subarticular tubercles feeble; a small oval inner, and a rather indistinct, rounded outer metatarsal tubercle. The tibio-tarsal articulation reaches the tip of the snout. Skin smooth, finely granular above; a strong supratemporal fold. Dark brown above, with elegant symmetrical darker markings, viz., chevron-shaped bands on the back, oblique streaks on the flanks, and bars of unequal width on the limbs; lower parts white, throat with a few brown spots.

From snout to vent 50 millim.

A single female specimen from Cachabé.

13. *HYLODES GULARIS*, sp. n. (Plate XV. fig. 3.)

Tongue pyriform, entire. Vomerine teeth in two short oblique series behind the choanæ. Head moderate, as long as broad; snout rounded, as long as the diameter of the orbit; canthus rostralis distinct; loreal region feebly oblique, concave; nostril much nearer the tip of the snout than the eye; interorbital space a little broader than the upper eyelid; tympanum distinct, two fifths the diameter of the eye. Fingers short, first shorter than second; toes short, free; disks rather large, as large as the tympanum; subarticular tubercles feebly prominent; a feebly prominent, oval, inner metatarsal tubercle. The tibio-tarsal articulation reaches the posterior border of the eye. Skin smooth above and below; a strong fold across the breast. Pale brown above, with round blackish spots; a blackish cross-bar between the eyes, and a dark streak from the eye to the shoulder; lower parts white. Male with an external vocal sac forming a strong fold along each side of the gular region.

From snout to vent 24 millim.

A single male specimen from Cachabé.

14. *HYLODES LATIDISCUS*, sp. n. (Plate XV. fig. 4.)

Tongue oval, slightly nicked behind. Vomerine teeth in two short transverse series behind the choanæ, on a level with the palatine bones. Head large, as long as broad or a little broader than long, much depressed; snout rounded, a little longer than the diameter of the orbit; canthus rostralis distinct; loreal region very oblique, concave; nostril much nearer the tip of the snout than the eye; vertex concave; interorbital space a little narrower than the upper eyelid; tympanum distinct, one third to two fifths the diameter of the eye. Fingers moderate, first shorter than second, the tips dilated into very large disks, which are broader than long and measure three fifths the diameter of the eye; toes moderate, free, the disks large, but a little smaller than those of the fingers; subarticular tubercles feeble; an elongate inner metatarsal tubercle, measuring about two thirds the length of the inner toe; a very indistinct outer metatarsal tubercle. The tibio-tarsal articulation reaches the

eye. Skin finely granular above, with small warts, which are largest on the head, and one of which, on the upper eyelid, may be large and conical, horn-like; a strong fold above the tympanum; belly and lower surface of thighs granular. Dark grey-brown or vinaceous red above, with blackish spots and marblings; limbs with more or less distinct, irregular, dark cross-bars; whitish beneath; sides of throat, belly, and lower surface of limbs finely speckled, as if powdered with brown. Male without vocal sac.

From snout to vent 54 millim.

Two specimens from Cachabé.

15. *SYRRHOPUS AREOLATUS*, sp. n. (Plate XIV. fig. 3.)

Snout rounded, as long as the eye, which is large; canthus rostralis rounded; loreal region concave, oblique; interorbital space as broad as the upper eyelid; tympanum feebly distinct, about one third the diameter of the eye. Fingers rather short, first shorter than second; toes rather short, quite free; disks well developed; subarticular tubercles feebly prominent. The tibio-tarsal articulation reaches the eye. Skin areolate or coarsely granular above and beneath. Greenish yellow above, spotted or dotted with reddish brown; thighs colourless; lower parts white. Male with an internal vocal sac.

From snout to vent 24 millim.

One specimen from Cachabé and two from Chimbo.

16. *LEPTODACTYLUS PULCHER*, sp. n. (Plate XIV. fig. 4.)

Tongue oval, entire. Vomerine teeth in two long arched series behind, and extending outwards beyond the choanæ. Head as long as broad; snout rounded, as long as the diameter of the orbit; canthus rostralis distinct; loreal region concave; nostril nearer the tip of the snout than the eye; interorbital space as broad as the upper eyelid; tympanum very distinct, two thirds the diameter of the eye. Fingers moderate, first extending a little beyond second; toes moderate, not fringed; tips of fingers and toes swollen, feebly but distinctly dilated; subarticular tubercles strong; two small, prominent metatarsal tubercles; a feebly prominent, oval tubercle on the tarsus nearer the foot than the tibia. The tibio-tarsal articulation reaches between the eye and the tip of the snout. Skin smooth; a ventral discoidal fold. Grey-brown above, with symmetrical blackish, light-edged markings forming a chain along the middle of the back; lips with blackish bars; a white spot on the tip of the snout; a dark oblique band, gradually widening, from the eye to the side of the body; limbs with regular dark cross-bars; throat brown, with white spots, which are most regular round the mandible; belly white, uniform or spotted with brown.

From snout to vent 24 millim.

Three specimens from Chimbo. Probably young.

17. *LEPTODACTYLUS PENTADACTYLUS* Laur.

Cachabé.

BUFONIDÆ.

18. BUFO HÆMATITICUS Cope.

Cachabé.

19. BUFO GLABERRIMUS Gthr.

Paramba and Cachabé.

The largest specimen measures 145 millim. from snout to vent. Young pale greyish above, spotted or marbled with black.

20. BUFO MARINUS L.

Chimbo.

21. BUFO TYPHONIUS L.

Paramba and Cachabé.

22. BUFO CONIFERUS Cope.

Cachabé. Numerous specimens.

The supraorbital, postorbital, and parietal ridges form a regular Λ -shaped figure, the two latter being at right angle to each other; interorbital space broader than the upper eyelid; tympanum two thirds to three fourths the diameter of the eye. The tarso-metatarsal articulation reaches the tip of the snout or between the latter and the eye. First finger shorter than second. Toes half or two thirds webbed; subarticular tubercles single. Male with an internal vocal sac and black nuptial excrescences on the inner and second finger. Brown or olive above, with more or less distinct large blackish insuliform spots; some specimens uniform blackish above; throat and breast dark brown in the males.

From snout to vent 88 millim.

HYLIDÆ.

23. HYLA ROSENBERGI, sp. n. (Plate XVI.)

Tongue subcircular, entire, adherent. Vomerine teeth between the very large choanæ, in two angular series forming together a Λ -shaped figure. Head much depressed, a little broader than long; snout rounded, a little longer than the diameter of the orbit; canthus rostralis indistinct; loreal region very oblique, concave; interorbital space as broad as the upper eyelid; tympanum very distinct, circular, three fourths to four fifths the diameter of the eye. Three outer fingers entirely webbed; a distinct rudiment of pollex, much developed in the male; toes entirely webbed; disks of fingers and toes large, three fifths to two thirds the diameter of the eye; subarticular tubercles very prominent; two feeble folds along the tarsus. The tibio-tarsal articulation reaches a little beyond the tip of the snout. Upper surface granulate and with small, round, pearl-like warts; no dermal appendage to the heel; throat, belly, and lower surface of thighs covered with small

granules. Yellowish, greyish, or reddish brown above, more or less distinctly spotted or marbled with brown or blackish; flanks sometimes with dark vertical bars; a continuous or interrupted blackish vertebral line, commencing between the nostrils, often present; lower parts white. Male with an internal vocal sac and a large flat gland on the flanks.

From snout to vent 97 millim.

Several specimens from Cachabé.

This fine tree-frog, which I have great pleasure in naming after its discoverer, is nearest allied to *H. maxima*, Laur., from which it differs in several points, among which I would draw special attention to the presence of a large flat gland on the sides in males, a secondary sexual character which finds its nearest parallel in the humeral gland of *Pelobates* and various species of *Rana*.

24. *HYLA BAUDINII* D. & B.

Cachabé.

The habitat of this species was believed to be restricted to Texas, Mexico, and Central America. Mr. Rosenberg has now obtained it at Buenaventura, Colombia, and, in great abundance, at Cachabé, in Northern Ecuador.

25. *NOTOTREMA MARSUPIATUM* D. & B.

26. *NOTOTREMA ANGUSTIFRONS*, sp. n. (Plate XVII. fig. 1.)

Tongue large, subcircular, slightly nicked and scarcely free behind. Vomerine teeth in two straight series between the choanæ. Head moderate, broader than long; nasal and frontoparietal bones rugose and confluent with the skin; snout deep, vertically truncate at the end, as long as the diameter of the eye; canthus rostralis strong; loreal region concave; interorbital space narrower than the upper eyelid; tympanum moderately distinct, one third the diameter of the eye. Fingers long, with a slight rudiment of web; toes almost entirely webbed; disks larger than the tympanum; subarticular tubercles moderate. The tibio-tarsal articulation reaches beyond the tip of the snout. Skin smooth; belly and lower surface of thighs granular. Olive-grey or brown above, clouded with darker, or with very indistinct reddish-brown cross-bars on the body; upper lip cream-colour, with dark brown spots; limbs with dark cross-bars; flanks and lower parts white, spotted with dark brown; a round white spot at the base of each thigh, near the vent. Male without vocal sac.

From snout to vent 73 millim.

Two specimens, male and young female, from Cachabé.

27. *NOTOTREMA CORNUTUM*, sp. n. (Plate XVIII.)

Tongue rather small, circular, entire, adherent. Vomerine teeth in two straight series behind the choanæ. Head moderate, broader than long; skin free from the skull; snout rounded, with distinct canthus and concave loreal region; interorbital region concave, with

a prominent ridge on each side, narrower than the upper eyelid, which is produced in a triangular horn-like appendage; tympanum moderately distinct, vertically oval, half the diameter of the eye. Fingers free; toes half webbed; disks larger than the tympanum; subarticular tubercles feebly prominent. The tibio-tarsal articulation reaches beyond the tip of the snout. Skin finely areolate above and on the throat, granular on the belly and under the thighs; heel with a very small, triangular dermal appendage. Greyish above, with a tinge of red on the back; a broad dark grey median stripe from the end of the snout to the vent, and a dark grey lateral stripe from the eye to the groin; two dark bars below the eye; whitish beneath, belly and lower surface of hind limbs marbled with brown; a round white spot at the base of each thigh, below the vent.

From snout to vent 76 millim.

A single female specimen from Cachabé, with nine well-developed young in the dorsal pouch; these young measure 19 millim. from snout to vent, and are provided with large bell-shaped gills as figured by Weinland in *N. oviferum*.

28. *HYLELLA PARABAMBÆ*, sp. n. (Plate XVII. fig. 2.)

Tongue circular, indistinctly nicked, and scarcely free behind. Head broader than long; snout rounded, as long as the diameter of the orbit; interorbital space broader than the upper eyelid; tympanum distinct, one fourth the diameter of the eye. First and second fingers equal; outer fingers two thirds webbed; toes almost entirely webbed; disks well developed, those of the fingers half the diameter of the eye; subarticular tubercles feeble. The tibio-tarsal articulation reaches a little beyond the tip of the snout. Skin smooth; lower belly and subanal region with wide-meshed areolation. Purplish-blue above (in spirit), white beneath; a few small darker spots on the upper surface of the leg.

From snout to vent 26 millim.

A single specimen from Paramba.

APODA.

CÆCILIIDÆ.

29. *CÆCILIA ISTHMICA* Cope.

Paramba and Cachabé.

EXPLANATION OF THE PLATES.

PLATE X.

Fig. 1. *Anolis peraccae*, p. 108.

2. „ *elegans*, p. 109.

3. „ *chloris*, p. 110.

4. „ *lemniscatus*, p. 113.

Figs. 1a, 2a, 3a, 4a. Upper views of heads, $\times 2$.

PLATE XI.

- Fig. 1. *Anolis maculiventris*, p. 111.
2. „ *granuliceps*, p. 111.
3. „ *gracilipes*, p. 112.
Figs. 1a, 2a, 3a. Upper views of heads, $\times 2$.

PLATE XII.

- Fig. 1. *Synophis miops*, p. 115. Upper view of head and neck, and upper, lower, and side views of head, $\times 2$.
2. *Leptognathus ellipsifera*, p. 117. Upper, lower, and side views of head and anterior part of body.

PLATE XIII.

- Elaps rosenbergi*, p. 117. Upper, lower, and side views of head and anterior part of body.

PLATE XIV.

- Fig. 1. *Phyllobates infraguttatus*, p. 118.
1 a. Lower view.
2. *Hylodes anomalus*, p. 119.
2 a. Open mouth.
3. *Syrhopus areolatus*, p. 122.
4. *Leptodactylus pulcher*, p. 122.

PLATE XV.

- Fig. 1. *Hylodes longirostris*, p. 120.
1 a. Open mouth.
2. *Hylodes achatinus*, p. 120.
2 a. Open mouth.
3. *Hylodes gularis*, p. 121.
3 a. Gular region, $\times 2$.
4. *Hylodes latidiscus*, p. 121.
4 a. Open mouth.

PLATE XVI.

- Hyla rosenbergi*, p. 123. With open mouth and side view of head.

PLATE XVII.

- Fig. 1. *Nototrema angustifrons*, p. 124. With open mouth and side view of head.
2. *Hylella parabambæ*, p. 125.

PLATE XVIII.

- Nototrema cornutum*, p. 124. With open mouth, side view of head, and embryo from the pouch.
-



1a.

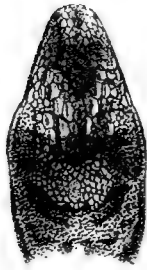

4a.



3a.

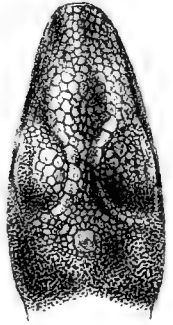

2a.

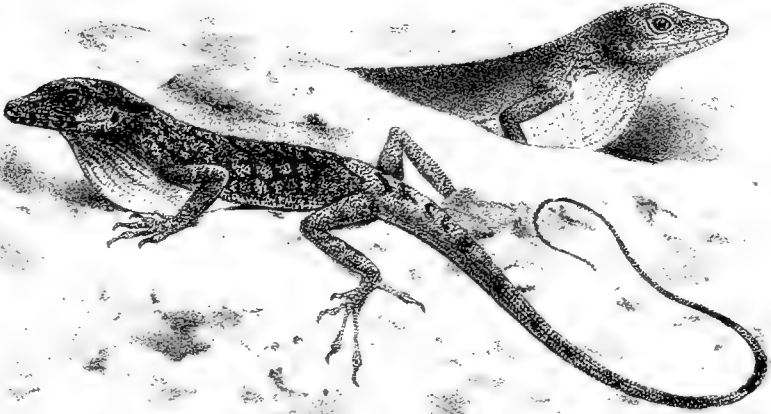

3.

1.

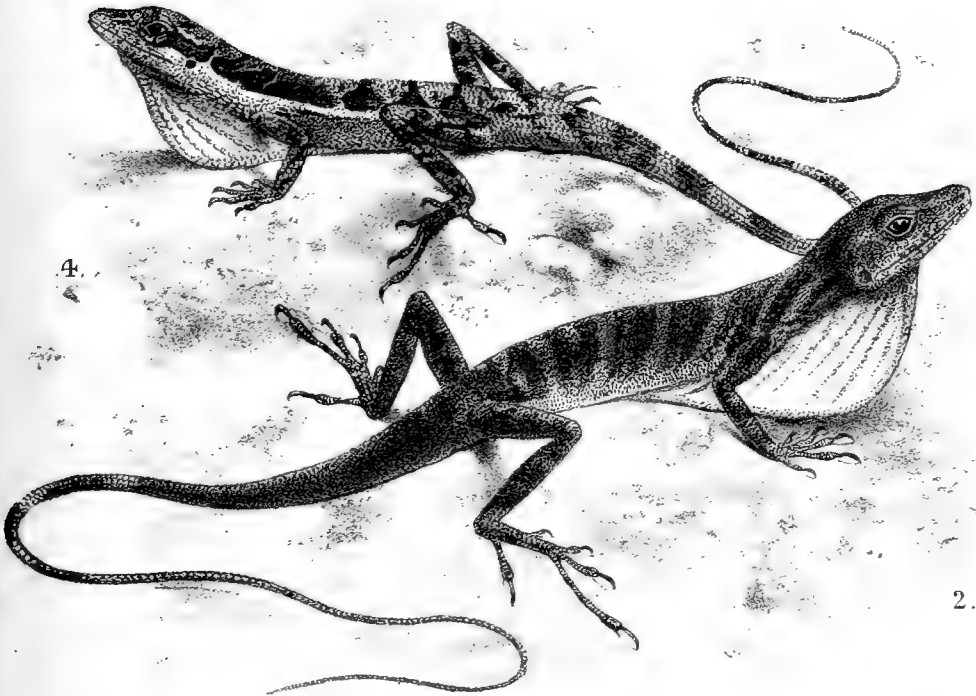

2.

P.J.Smit del. et lith.

Mintern Bros. imp.

1. ANOLIS PERACCÆ.
3. ANOLIS CHLORIS.

2. ANOLIS ELEGANS.
4. ANOLIS LEMNISCATUS.





2a.

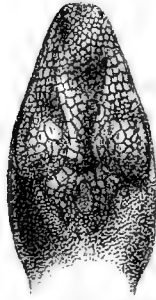

3a.



1a.



2.



1.

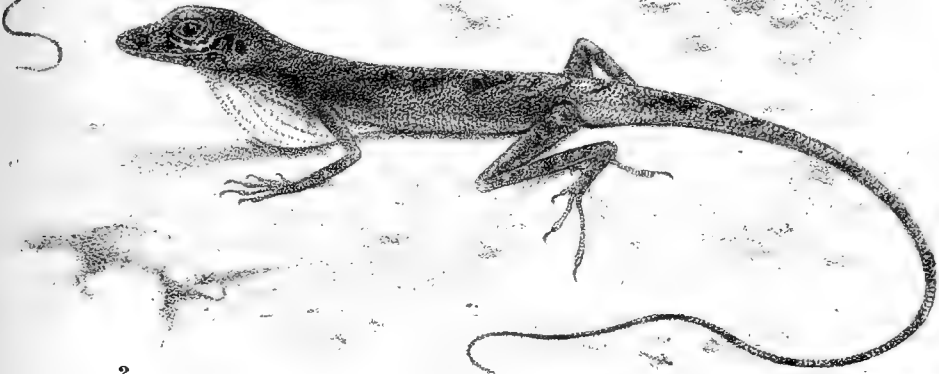

3.



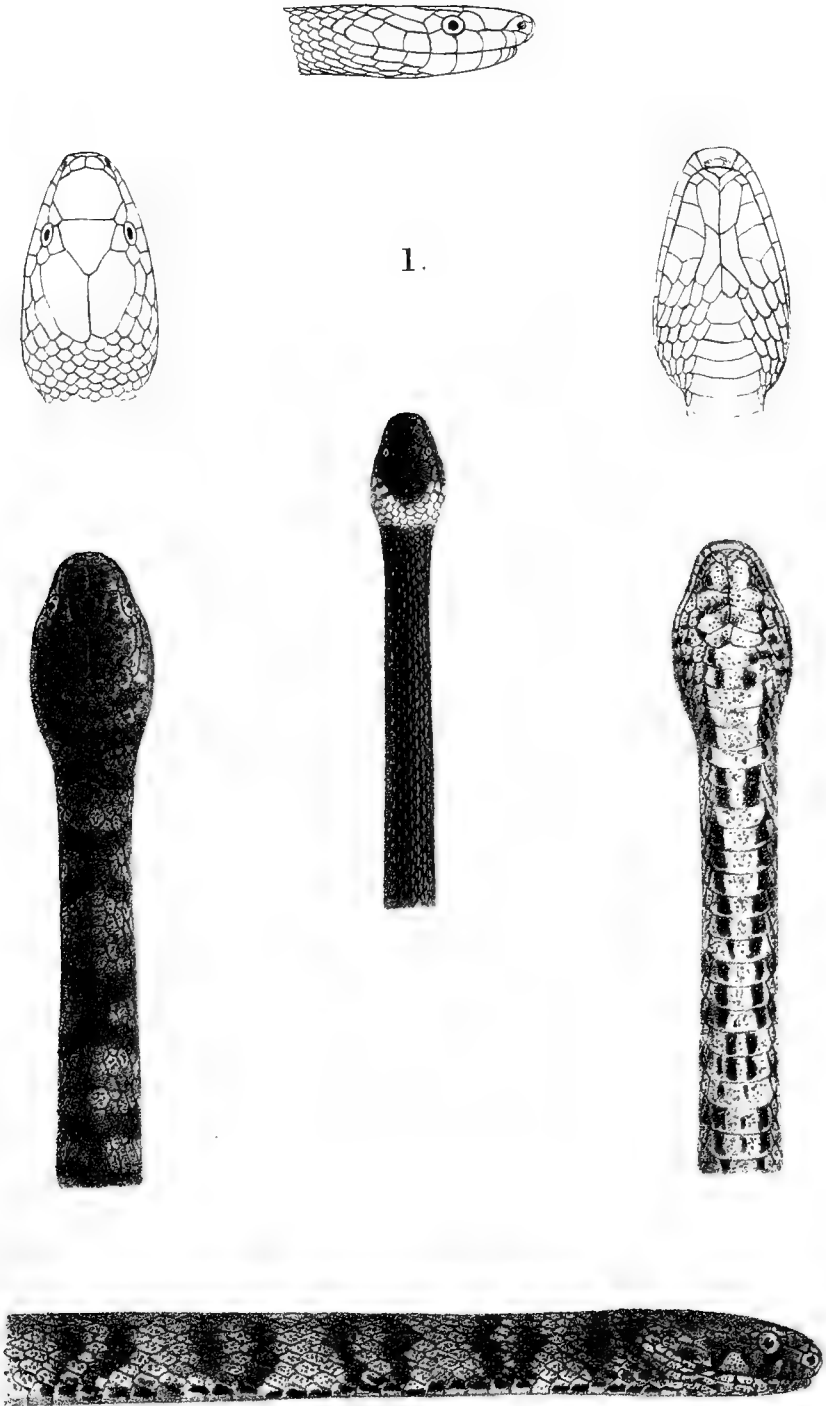

2 .

P.J.Smit del. et lith

Mintern.Bros. imp.

1. SYNOPHIS MIOPS. 2. LEPTOGNATHUS ELLIPSIFERA.



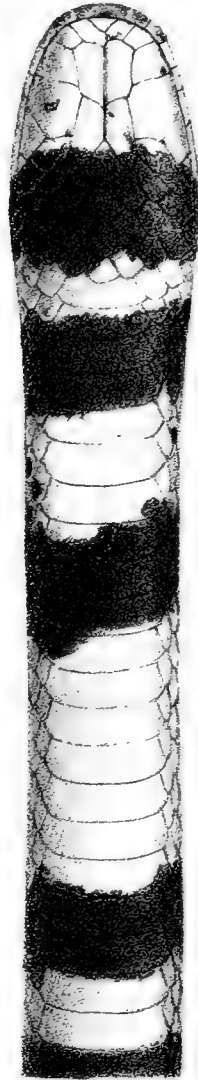





P.J. Smit del. et lith.

Mintern Bros. imp.

1. PHYLLOBATES INFRAGUTTATUS. 2. HYLODES ANOMALUS.
3. SYRRHOPUS AREOLATUS. 4. LEPTODACTYLUS PULCHER.

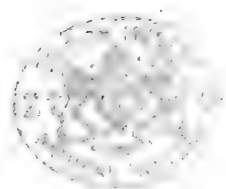



4a.



4.

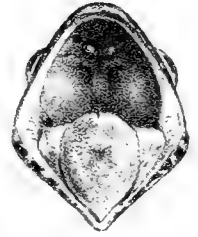

2a.



1a.



3.



3a.

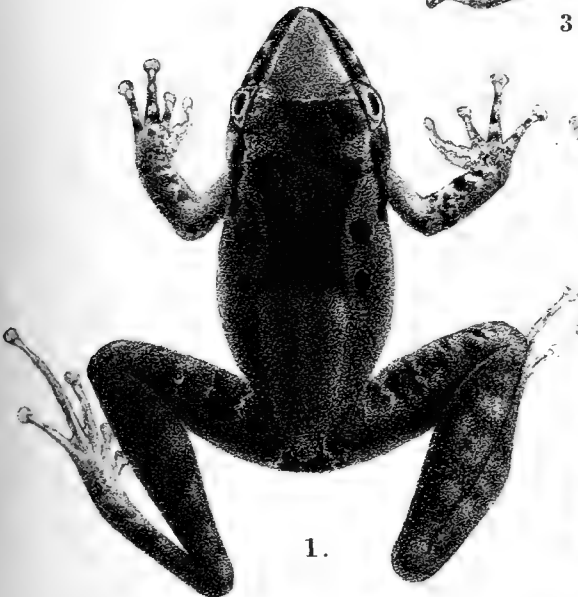

1.

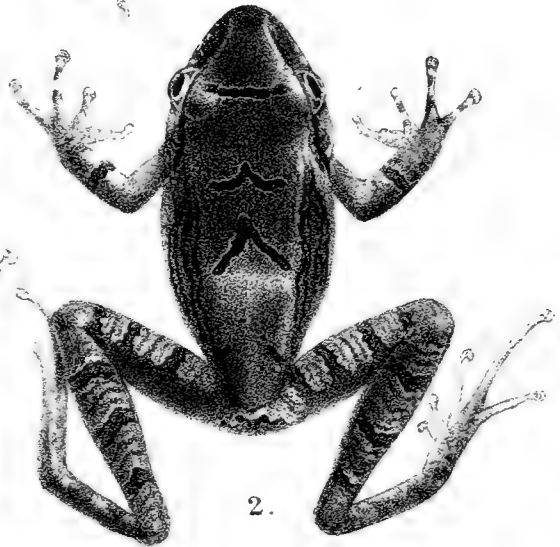

2.

P.J. Smit del. et lith

Mintern Bros. imp.

1. HYLODES LONGIROSTRIS.

2. HYLODES ACHATINUS.

3. HYLODES GULARIS.

4. HYLODES LATIDISCUS.





P.J. Smit del. et lith.

Mintern Bros. imp.

HYLA ROSENBERGI.



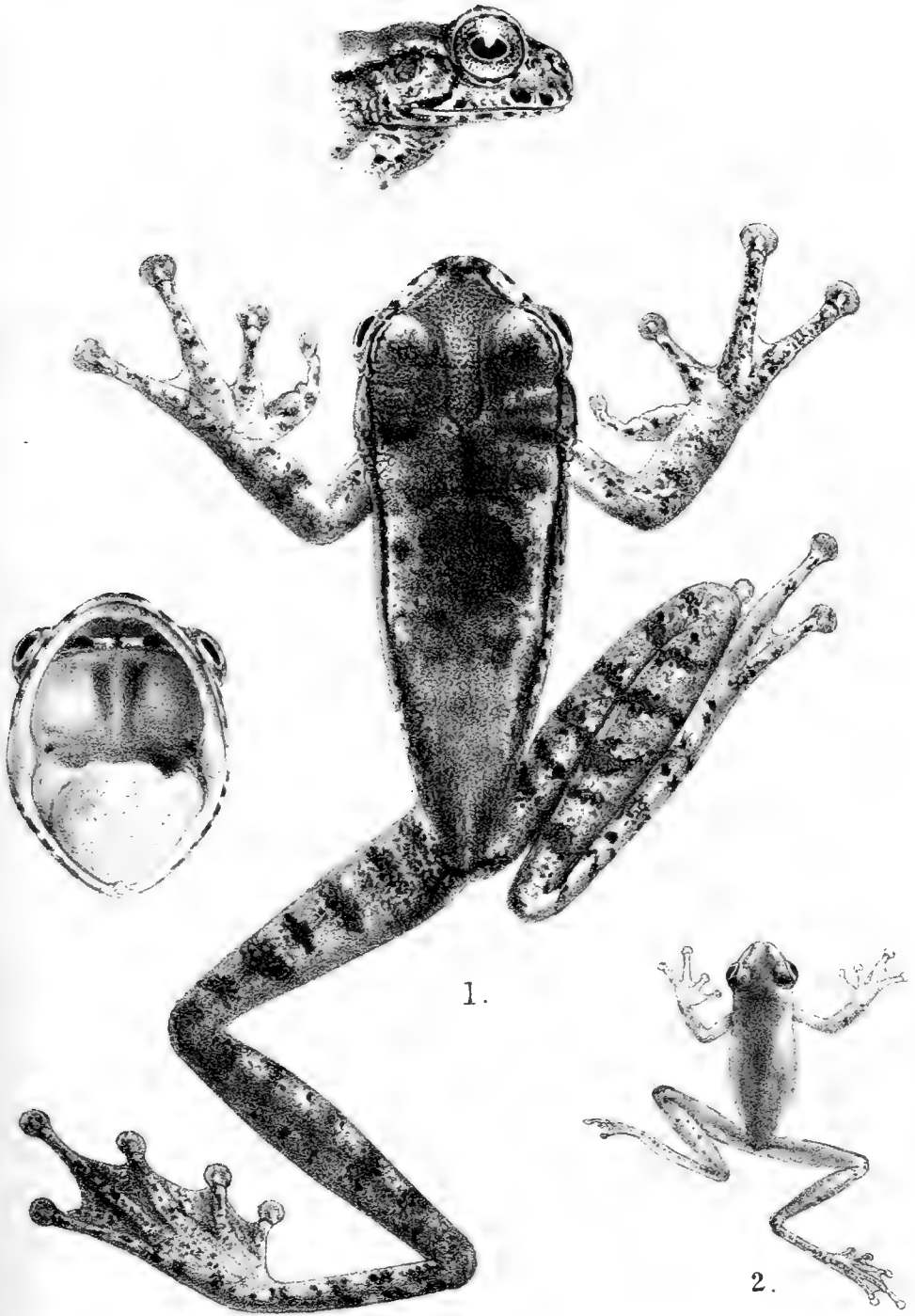

P.J.Smit del. et lith.

Mintern Bros. imp.

1. NOTOTREMA ANGUSTIFRONS. 2. HYLELLA PARABAMBÆ.



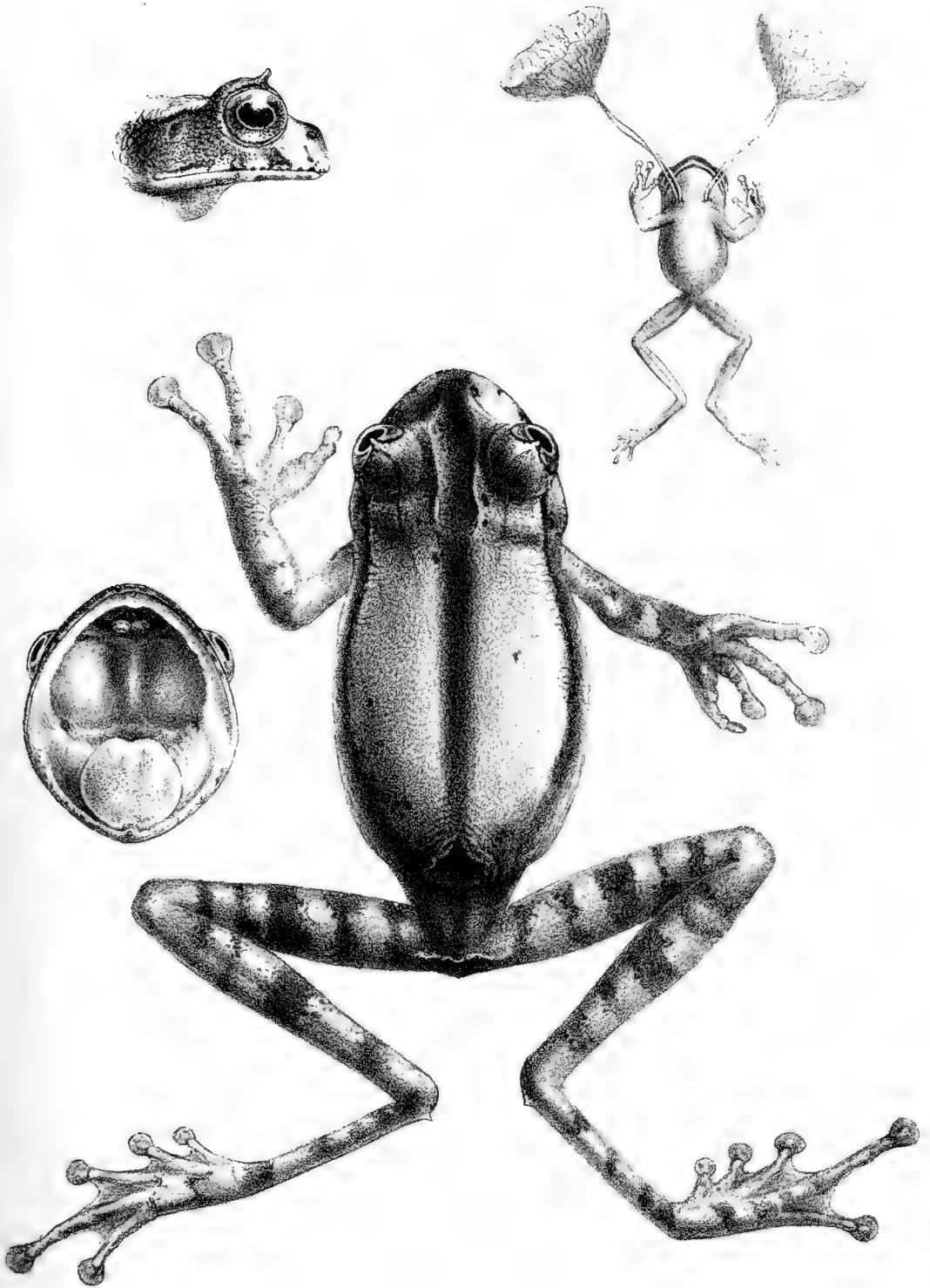

P.J.Smit del. et lith.

Mintern.Bros. imp.

NOTOTREMA CORNUTUM.



March 1, 1898.

Dr. W. T. BLANFORD, F.R.S., F.Z.S., in the Chair.

Mr. Boulenger exhibited, alive, a hybrid male Newt, the result of the crossing of a hybrid *Molge cristata* × *M. marmorata* with the former species, which had been reared at Argenton-sur-Creuse by M. R. Rollinat.

Hybrids between the above-named species had been described many years ago as a distinct species, *M. blasii* de l'Isle, and, although their true nature had been suspected by the describer himself, it was only within the last few years that their hybrid origin had been seriously advocated by Peracca, Parâtre, and Héron-Royer. However, in the absence of direct evidence, the conclusions of these observers had not been generally accepted, and in his recently published 'Schwanzlurche Europas' Bedriaga had provisionally maintained *M. blasii* as a distinct species. M. Rollinat's successful experiments have now removed all doubts on this point, and the specimen exhibited, as well as others obtained by the same gentleman, showed the hybrids to be fertile *inter se*, and, by crossing again with the parent forms, to revert to either, as had been presumed by the above-mentioned authors. The present specimen could hardly be distinguished from a typical *Molge cristata* except for the colour of the ventral surface, which was of a duller orange.

It was Mr. Boulenger's intention to institute, in conjunction with his friend Mr. Albert Pam, F.Z.S., a further experiment during the coming spring, by placing in a large tank a number of female *M. marmorata* from France with males of *M. cristata* from England, in the hope of obtaining offspring that would be referable to the much-discussed *M. blasii*. The results of the experiment, if any, would be laid before the Society.

Mr. W. E. de Winton exhibited the head-skin of a Roan Antelope (*Hippotragus equinus*) from British East Africa. It had been brought home by Mr. S. L. Hinde, to whom it was presented by the Collector at Machakos; unfortunately the name of the Collector and the exact locality where the animal had been shot were not noted when it was deposited at the British Museum. The interest in this specimen lay in the fact that it was believed to be the first that had been brought to this country, although the species had long been known to occur in that district¹. This Antelope would seem to have the widest range of any known form, extending as it did from the Cape Colony to Abyssinia, where Sir Samuel Baker has obtained it, and crossing the continent to Senegal. The Abyssinian form has been described as distinct by Von Heuglin under the name of *H. bakeri*, but its right to the rank of a separate species was, in Mr. de Winton's opinion, extremely doubtful.

¹ Cf. Jackson, P. Z. S. 1897, p. 454.

Mr. Sclater exhibited two skins of the White-legged Falconet (*Microhierax melanoleucus*), being those of the two living examples from Foochow presented by Messrs. Rickett and La Touche and received on the 6th December last (see above, p. 2). They had lived in apparently good health until February 6th, but had both died on that day. No cause of death was ascertainable on dissection. Although one bird was slightly larger than the other, both were found to be of the female sex.

The pretty little Hawks had lived in the Society's Gardens very amicably together in a large cage, but passed the whole of the day-time in a small box fitted up inside the cage, only coming out into the cage in the evening, so that they were, no doubt, crepuscular in their habits. They had been fed at the Gardens on sparrows and mice, which they ate with avidity. No doubt insects would have been better for them, but it was difficult to get sufficient insect food in the winter.

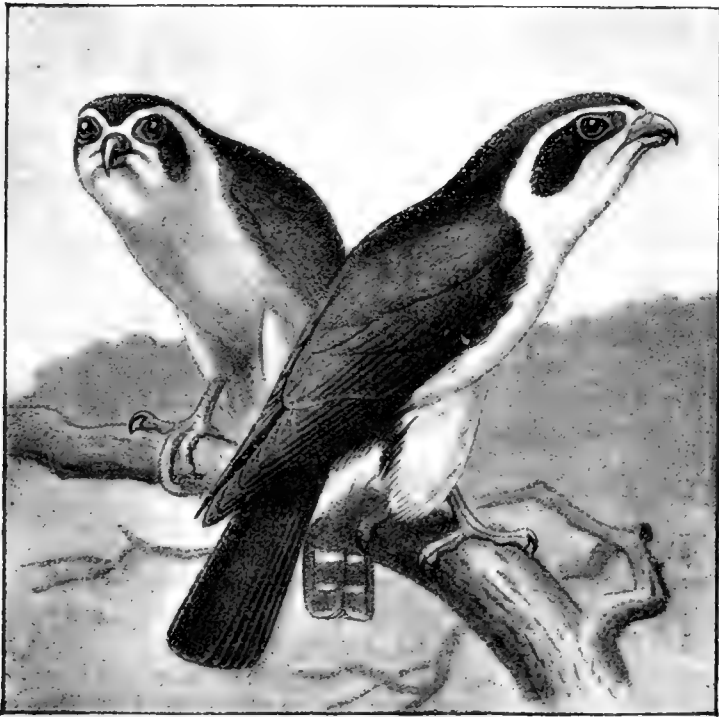

The White-legged Falconets. (Field, xci. p. 141, 1898.)

Mr. Sclater called attention to the excellent illustration of these birds drawn by Frohawk and published in 'The Field' for January 29th last (together with an article on these birds by Mr. W. B. Tegetmeier, F.Z.S.), and exhibited copies of the drawing, which by the kindness of the Proprietors of 'The Field' he was enabled to reproduce.

The following papers were read:—

CONTENTS (*continued*).

February 1, 1898 (*continued*).

	Page
1. On the Anatomy of an Australian Cuckoo, <i>Scythrops novæ-hollandiæ</i> . By FRANK E. BEDDARD, M.A., F.R.S., Prosecutor to the Society	44
2. On a Collection of Lepidoptera made by Mr. F. V. Kirby, chiefly in Portuguese East Africa. By ARTHUR G. BUTLER, Ph.D., F.L.S., F.Z.S., &c., Senior Assistant-Keeper, Zoological Department, British Museum	49
3. On the Vascular System of the Chiroptera. By N. H. ALCOCK, B.A., M.D.; Assistant to the Professor of Institutes of Medicine, Trinity College, Dublin.—Part I. Thoracic Vessels of <i>Pteropus medius</i> ; with a Summary of the Literature of the Chiroptera	58

February 15, 1898.

The Secretary. Report on the Additions to the Society's Menagerie in January 1898.....	79
Mr. D. Le Souëf. Letter from, on the transfer by the mother of an embryo Kangaroo (<i>Macropus giganteus</i>) by her mouth into her pouch	79
Mr. Arthur Thomson. Report on the Insect-house for 1897	80
The Secretary. Exhibition of a series of Lepidopterous Insects showing the system of mounting adopted in 'Denton's Patent Butterfly Tablets'	81
1. Contributions to the Osteology of Birds.—Part I. <i>Steganopodes</i> . By W. P. PYCRAFT. (Plates VII. & VIII.)	82
2. On the Skeleton of Regenerated Limbs of the Midwife-Toad (<i>Alytes obstetricans</i>). By W. G. RIDWOOD, D.Sc., F.L.S., F.Z.S.	101
3. Description of a new Sea-Snake from Borneo. By G. A. BOULENGER, F.R.S. (Plate IX.)	106
4. An Account of the Reptiles and Batrachians collected by Mr. W. F. H. Rosenberg in Western Ecuador. By G. A. BOULENGER, F.R.S. (Plates X.—XVIII.).....	107

March 1, 1898.

Mr. Boulenger. Exhibition of a living specimen of a hybrid Newt between a male <i>Molge cristata</i> × <i>M. marmorata</i> and a female of <i>M. cristata</i>	127
Mr. W. E. de Winton. Exhibition of and remarks upon a head-skin of a Roan Antelope (<i>Hippotragus equinus</i>) from British East Africa.....	127
Mr. Selater. Exhibition of and remarks upon two skins of the White-legged Falconet (<i>Microhierax melanoleucus</i>).....	128

LIST OF PLATES.

1898.

PART I.

Plate	Page
I. <i>Felis dominicanorum</i>	2
II. Hyoid of <i>Alytes obstetricans</i>	4
III. } African Oteniform Spiders	13
IV. }	
V. } Stomatopoda from the South Pacific	32
VI. }	
VII. Osteology of Steganopodes. 1. <i>Fregata ariel</i> . 2. <i>Phaëthon flavirostris</i> . 3. <i>Phalacrocorax carbo</i>	82
VIII. Osteology of Steganopodes. 1, 1 a, 5. <i>Phaëthon flavirostris</i> . 2. <i>Sula leucogastra</i> . 3. <i>Phalacrocorax carbo</i> . 4. <i>Fregata ariel</i> . 6. <i>Pelecanus rufescens</i>	82
IX. <i>Hydrophis floweri</i>	106
X. 1. <i>Anolis peraccae</i> . 2. <i>A. elegans</i> . 3. <i>A. chloris</i> . 4. <i>A. temniscatus</i>	} 107
XI. 1. <i>Anolis maculiventris</i> . 2. <i>A. granuliceps</i> . 3. <i>A. gracilipes</i>	
XII. 1. <i>Synopsis miops</i> . 2. <i>Leptognathus ellipsifera</i>	
XIII. <i>Elaps rosenbergi</i>	
XIV. 1. <i>Phyllobates infraguttatus</i> . 2. <i>Hylodes anomalus</i> . 3. <i>Syrhopus areolatus</i> . 4. <i>Leptodactylus pulcher</i>	
XV. 1. <i>Hylodes longirostris</i> . 2. <i>H. achatinus</i> . 3. <i>H. gularis</i> . 4. <i>H. latidiscus</i>	
XVI. <i>Hyla rosenbergi</i>	
XVII. 1. <i>Nototrema angustifrons</i> . 2. <i>Hylella parabambæ</i>	
XVIII. <i>Nototrema cornutum</i>	

NOTICE.

The Proceedings are issued in *four* parts, as follows:—

- Part I. containing papers read in January and February, on June 1st.
 II. " " " " March and April, on August 1st.
 III. " " " " May and June, on October 1st.
 IV. " " " " November and December, on April 1st.



PROCEEDINGS

OF THE

GENERAL MEETINGS FOR SCIENTIFIC BUSINESS

OF THE

ZOOLOGICAL SOCIETY

OF LONDON

FOR THE YEAR

1898.

PART II.

CONTAINING PAPERS READ IN

MARCH AND APRIL.

AUGUST 1st, 1898.

PRINTED FOR THE SOCIETY,
SOLD AT THEIR HOUSE IN HANOVER SQUARE.

LONDON:
MESSRS. LONGMANS, GREEN, AND CO.,
PATERNOSTER-ROW.

[*Price Twelve Shillings.*]



LIST OF CONTENTS.

PART II.—1898.

March 1, 1898.

	Page
1. On certain Points in the Anatomy of the Cunning Bassarisc, <i>Bassariscus astutus</i> . By FRANK E. BEDDARD, M.A., F.R.S., Prosector to the Society, Examiner in Zoology in the University of London	129
2. A Revision of the African and Syrian Fishes of the Family <i>Cichlide</i> .—Part I. By G. A. BOULENGER, F.R.S. (Plate XIX.)	132
3. The Myology of the Terrestrial Carnivora.—Part II. By B. C. A. WINDLE, M.A., M.D., D.Sc., Professor of Anatomy at Mason University College, Birmingham, and F. G. PARSONS, F.R.C.S., F.Z.S., F.L.S., Lecturer on Comparative Anatomy at St. Thomas's Hospital, and Hunterian Professor at the Royal College of Surgeons.....	152
4. On the Lepidopterous Insects collected by Mr. G. A. K. Marshall in Natal and Mashonaland in 1895 and 1897. By ARTHUR G. BUTLER, Ph.D., F.L.S., F.Z.S., &c., Senior Assistant-Keeper, Zoological Department, British Museum. (Plate XX.).....	186

March 15, 1898.

The Secretary. Report on the Additions to the Society's Menagerie in February 1898	201
The Secretary. Exhibition of, on behalf of Sir Edmund Loder, Bart., and remarks upon, some photographs of the Beaver-pond at Leonardslee, Horsham	201
Mr. R. E. Holding. Exhibition of, and remarks upon, a pair of horns of the "Sunga" or Galla Ox of Abyssinia	202
Dr. G. Stewardson Brady, F.R.S. Notice of a Memoir on new or imperfectly-known Species of Ostracoda, chiefly from New Zealand	203
1. On the Early Post-larval Stages of the Common Crab (<i>Cancer pagurus</i>), and on the Affinity of that Species with <i>Atelecyclus heterodon</i> . By J. T. CUNNINGHAM, M.A. (Plate XXI.)	204
2. On some Mammals obtained by the late Mr. Henry Durnford in Chubut, E. Patagonia. By OLDFIELD THOMAS	210

Contents continued on page 3 of Wrapper.

1. On certain Points in the Anatomy of the Cunning Bassarisc, *Bassariscus astutus*. By FRANK E. BEDDARD, M.A., F.R.S., Prosector to the Society, Examiner in Zoology in the University of London.

[Received March 1, 1898.]

The opportunity of dissecting this imperfectly known Carnivore was afforded me by the death of a specimen acquired by the Society some two years since, the second example which has been exhibited alive at the Gardens. The abdominal viscera of the animal at its death were healthy to all appearance; but the skin in the neighbourhood of the anus had been macerated away—perhaps by diarrhœa, as the intestines were nearly empty and the animal had not taken food for a week. The tongue and palate were also diseased. Its body was, however, enormously fat, internally as well as externally.

So far as I am aware, the only accounts of the soft parts of this animal are by M. Gervais¹ and Sir W. H. Flower². The paper of the last-named naturalist is his well-known memoir upon the classification of the Carnivora, and deals chiefly with the skull; but in it he confirms M. Gervais's statement of the absence of a cæcum, which is so important a classificatory point. This paper established beyond question the association of *Bassariscus* with the Arctoid division of the Carnivora. Such new facts as I have to describe in the present communication are purely confirmatory of that conclusion.

§ Brain.

The brain conforms in every respect to the Arctoid type as defined by Sir W. Flower³, and, as is the case with smaller brains, it is less convoluted than is, for instance, the larger brain of *Gulo*⁴ figured by myself.

The hemispheres are divergent posteriorly, displaying most of the cerebellum. The fissure dividing the sagittal from the parietal gyrus does not reach the posterior margin of the cerebrum; it does so more nearly on the right side than the left. On the right side also there is a bridging convolution uniting the sagittal with the parietal gyrus; there are faint indications of this on the left side. As is usual in Carnivorous (not merely Arctoid) brains, the sagittal gyrus is sharply folded upon itself anteriorly, the sulcus which divides this region from the middle portion of the gyrus reaching the rhinal fissure below. The sagittal gyrus winds round the

¹ In 'Voyage de la Bonite,' 1841.

² "On the Value of the Characters of the Base of the Cranium, &c.," P. Z. S. 1869, p. 34.

³ "On the Anatomy of the Proteles," P. Z. S. 1869, p. 482.

⁴ "On the Brain of *Gulo*," P. Z. S. 1895, p. 140, fig. 1.

crucial sulcus, which is situated rather far forward. This part of the gyrus is perfectly smooth, there being no precrucial sulcus.

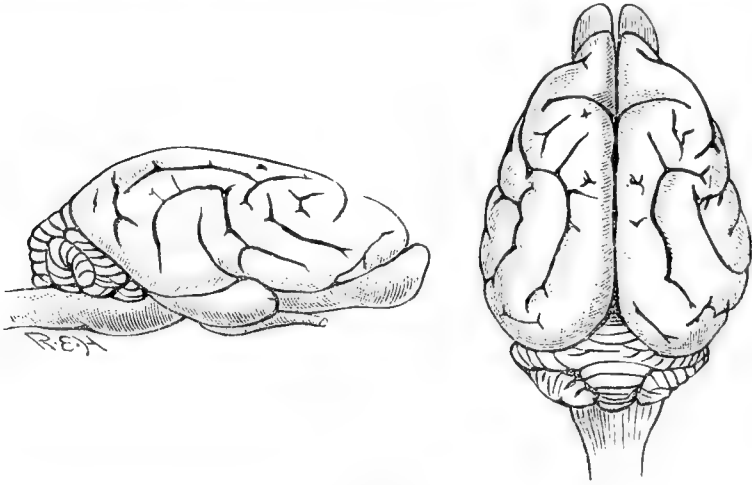

Brain of *Bassariscus astutus*.

Posteriorly to the crucial sulcus the sagittal gyrus, as is the case with the corresponding gyrus in other Arctoids, is marked by two fissures: one of these starts from the angle of the parietal sulcus and runs for a short distance anteriorly; the other is shorter and lies to the outside of it and is unconnected with any other furrow.

The anterior recurrent portion of the sagittal gyrus is much narrower than I have seen it in any Arctoid, not even excepting the smaller *Ictonyx*.

§ *Alimentary Canal.*

The *palate* was, as has been already mentioned, somewhat diseased posteriorly: I am not, therefore, able to be certain as to the arrangement of the ridges in this region. In the anterior part of the palate, just behind the incisor teeth, were three triangular cushions, their apices converging posteriorly. Immediately behind and springing from the interval between the canine and the first premolar is a ridge which does not meet its fellow in the middle line. Then come four complete ridges springing from the basis of the teeth, of which the first is very much more concave (backwards) than those which follow.

The *stomach* of the animal is not greatly elongated. It is, perhaps, slightly more globular than that of *Ælurus fulgens*, figured and described by Sir W. Flower¹. Its length when distended was 3 inches, by a greatest diameter of 2 inches. The omentum, loaded with fat, is not attached accurately along the greater curvature of the stomach. It is so attached for, perhaps, the first third of that curvature; afterwards it takes, so to speak, a short cut to the basis of the œsophagus, the line of its attachment being still curved and parallel to that of the greater curvature.

¹ "On the Anatomy of *Ælurus fulgens*," P. Z. S. 1870, p. 762.

The *spleen* measured $2\frac{3}{4}$ inches in length; it was rather broader at one end than at the other, but had no extra lobe or even indications of such.

The *pancreas* is rather peculiar, but apparently not unlike that of *Helictis*, in which the late Prof. Garrod described¹ it as "seven inches in length, its left terminal two inches being in relation with the narrow spleen." In *Bassariscus* this gland is L-shaped, the meeting-point of the two limbs, situated at the angle of the duodenum, being much wider than either of them is in its course. The upper limb, that which runs parallel with the commencement of the duodenum, is barely three inches in length; the limb which passes outwards in near relation to the spleen is five inches in length.

The *intestine*, from the duodenum to the anus, is as nearly as possible five feet in length. There is no cæcum, but the junction between the small and large intestines seems to be marked (as it is, for example, in *Cryptoprocta*²) by an unusually long Peyer's patch. The Peyer's patches in the animal were particularly well marked, owing to their deep pigmentation. This patch, to which I now refer, was narrow but no less than three inches in length. After it the internal surface of the intestine was rugose. This of course supports the view that the long Peyer's patch lies on the extremity of the small intestine. In front of this patch were nine or ten others, none of which, however, measured more than half an inch in length.

The *liver* of *Bassariscus* is not remarkable in any special way. The relative size of its component lobes may be thus expressed:—

$$\text{L.L. } 2 > \text{L.C. } 2\frac{1}{2} < \text{R.C. } 2\frac{1}{2} > \text{R.L.} = \text{C } 2 > \text{Sp.}$$

The right central lobe, which is the largest, is on the abdominal aspect completely divided into two by the cystic notch; on the dorsal surface the notch only extends as far as the fundus of the gall-bladder. The right half of the right central lobe is very slightly furrowed in a longitudinal direction. The caudate lobe is bifid at its extremity and has a small nearly free lobe attached to its diaphragmatic surface. The spigelian lobe is notched faintly at the extremity and also at both sides a little way from the extremity. The only liver which I have among the stores in my department with which to compare the liver of *Bassariscus* is that of *Ælurus fulgens*, which has been described and figured by Flower³. The chief differences which *Bassariscus* shows are: (1) the much greater relative size of right central; (2) the freedom of the right lateral and caudate lobes (they are firmly attached by their apposed surfaces in *Ælurus*); (3) the much smaller size of the spigelian lobe.

¹ "Notes on the Anatomy of *Helictis subaurantiacus*," P. Z. S. 1879, p. 306.

² F. E. Beddard, "On the Visceral and Muscular Anatomy of *Cryptoprocta*," P. Z. S. 1895, pp. 431, 432.

³ "On the Anatomy of *Ælurus fulgens*," P. Z. S. 1870, p. 763.

2. A Revision of the African and Syrian Fishes of the Family *Cichlidae*.—Part I. By G. A. BOULENGER, F.R.S.

[Received February 18, 1898.]

(Plate XIX.)

The *Cichlidae* form a very natural family of Perciform Acanthopterygians, which may be defined as follows:—

No suborbital lamina of the suborbitals; entopterygoid present, small. Præcaudal vertebræ with transverse processes from the third to the last; ribs, all but the last few nearly sessile, inserted behind the transverse processes, not at their extremity, and narrowly separated if at all from the centra. Nostril single on each side. Gill-membranes free from isthmus; five or six branchiostegals; gills four, a slit behind the fourth; pseudobranchiæ absent. Lower pharyngeal bones united, with persistent median suture. Soft portion of dorsal fin not more developed than the anal; latter with three or more spines.

The term "*Chromides*," by which this family is often designated, is inadmissible, the name *Chromis* having been originally intended for *Sparus chromis*, L.=*Chromis castanea*, Risso, a *Heliastes* of Cuvier and Valenciennes. Cuvier, in the second edition of the 'Règne Animal,' referred to *Labrus niloticus* only as a second species of his genus *Chromis*, the definition of which is drafted from *Sparus chromis*. *Sparus niloticus* can therefore not be retained as the type of *Chromis*, and must be placed in the genus *Tilapia* of Andrew Smith, in the family named *Cichlidae* by Bleeker (1859).

This family includes a large number of brackish- and freshwater fishes from Africa, Syria, India, and Central and South America, one species extending into Texas.

The nearest affinity of these Fishes is with the *Centrarchidae* and *Percidae*. A study of their skeleton shows them to bear no special relation to the *Pomacentridæ*, *Labridæ*, *Scaridæ*, or to any other division of the 'Pharyngognathi,' than which a more artificial group has never been conceived. Yet, I regret to say, it is very slow at being altogether abandoned, remains of it lingering here and there in the works of even the most advanced reformers—to wit, Gill's superfamilies *Pomacentroidea* and *Labroidea* (1893), corresponding to the Suborders *Chromides* and *Pharyngognathi* of Jordan and Evermann (1896).

In the present paper I shall deal only with the genera represented in Africa and Syria, of which I am able to distinguish nine. All agree in having the palate toothless, no supplemental maxillary, a single, continuous dorsal fin, and two distinct lateral lines. The number of vertebræ varies, in the specimens examined by me, between 26 and 38 (13-19+12-19).

I am under deep obligations to Professor Vaillant for his kind assistance in communicating to me the types of several species preserved in the Paris Museum. I have thus been enabled to

make this revision more complete than would otherwise have been possible, and to settle some points of synonymy which, from the imperfection of the original descriptions, would have remained unsolved. I seize this opportunity to express my thanks to Professor Vaillant for the valuable help I have received from him in connection with the celebrated collection in his charge, on this and many previous occasions.

My thanks are also due to Mr. J. Green, who has kindly furnished me with sciagraphs of some unique specimens, by means of which I have been able to ascertain the number of vertebræ.

Synopsis of the Genera.

- I. No sheath to the vertical fins.
- A. Anal spines VI or VII; teeth conical, some enlarged and canine-like
- B. Anal spines III or IV.
1. Teeth not notched, unicuspid.
- a. Alveolar surface of jaws narrow or moderately broad.
- a. No pad-like papillose prominence close to the upper part of the branchial arches.
- * Teeth in one or two series, with more or less enlarged or canine-like ones at the symphysis
- ** Teeth in two or more series in both jaws, outer largest and more or less distinctly curved inwards; no enlarged teeth at the symphysis
- β. A pad-like prominence close to the upper part of the branchial arches.
- * Teeth in two or more series in both jaws, outer largest and more or less distinctly curved inward ...
- ** Teeth in one or two series, some of the larger ones with the crown bent at an angle to the shaft and directed forward or backward ...
- b. Alveolar surface of jaws extremely broad, with innumerable minute teeth with compressed, oblique crowns.....
2. Teeth all or greater part notched or tricuspid.
- a. Alveolar surface of jaws narrow or moderately broad; all the teeth notched or tricuspid
- b. Alveolar surface of jaws very broad; outer teeth large, with nail-shaped entire crowns, those of the inner rows tricuspid
- II. Vertical fins folding in a scaly sheath; anal spines VIII or IX; teeth spatulate, in a single row
1. *Lamprologus*, Schilth.
2. *Hemichromis*, Peters.
3. *Paratilapia*, Blkr.
4. *Pelmatochromis*, Sldr.
5. *Chromidotilapia*, Blgr.
6. *Corematodus*, Blgr.
7. *Tilapia*, Smith.
8. *Docimodus*, Blgr.
9. *Paretroplus*, Blkr.

The three latter genera will be dealt with in the second part of this paper,

1. LAMPROLOGUS.

Lamprologus, Schilthuis, Tijdschr. Nederl. Dierk. Ver. (2) iii. 1891, p. 85.

Body rather elongate; scales ctenoid. Jaws with a band of very small conical teeth, with enlarged canines in front. Maxillary exposed. Dorsal with 18 or 19 spines, anal with 6 or 7. Vertebræ 31 (15+16).

A single species, from the Congo.

This genus is easily distinguished from other African forms by the number of anal spines; from the American *Heros* by the maxillary not being entirely concealed when the mouth is closed; from *Etroplus* and *Paretroplus* by the dorsal not folding in a scaly sheath, and by the dentition.

1. LAMPROLOGUS CONGOENSIS.

Lamprologus congoensis, Schilthuis, l. c. pl. vi. fig. 1.

Depth of body $3\frac{3}{4}$ to 4 times in total length, length of head 3 to $3\frac{1}{4}$. Snout a little longer than diameter of eye, which is $3\frac{1}{2}$ to 4 times in length of head, and equals or slightly exceeds interorbital width; maxillary extending to below anterior border of eye; head naked, or with a few isolated scales on the opercle. Gill-rakers short, 9 or 10 on lower part of anterior arch. Dorsal XVIII-XIX 8-10; spines increasing in length to the last, which measures $\frac{2}{5}$ length of head and $\frac{1}{2}$ longest soft rays. Pectoral $\frac{3}{4}$ to $\frac{3}{4}$ length of head. Ventral reaching vent or origin of anal. Anal VI-VII 5-6. Caudal rounded, subacuminate. Caudal peduncle as long as deep. Scales 42-53 $\frac{6-7}{14-15}$; lat. l. $\frac{23-26}{8-13}$. Brownish or olive, uniform or with four or five rather indistinct darker cross-bars; a dark streak behind the eye, and a blackish opercular spot; vertical fins grey, uniform or with small lighter and darker spots.

Total length 100 millim.

Upper and Lower Congo.

2. HEMICHROMIS.

Hemichromis, Peters, Mon. Berl. Ac. 1857, p. 403; Günther, Cat. iv. p. 274 (1862).

Chromichthys, Guichenot, in A. Duméril, Arch. Mus. x. 1859, p. 257.

Hemichromis, part., Pfeffer, Thierw. O.-Afr., Fische, p. 19 (1896).

Body short or moderately elongate; scales cycloid. One or two series of conical teeth in the jaws, the second series, if present, short and consisting of a few very small teeth; the two middle teeth in the jaws larger than the others, in the adult at least. Maxillary exposed. Dorsal with 13 to 15 spines, anal with 3. Vertebræ 26-28 (15+13 in *H. fasciatus*, 14+12 in *H. bimaculatus*).

North and West Africa.

1. *HEMICHROMIS FASCIATUS*.

Hemichromis fasciatus, Peters, Mon. Berl. Ac. 1857, p. 403; Günth. Cat. iv. p. 274 (1862); Bleek. Nat. Verh. Vet. Haarlem, xviii. 1863, no. 2, p. 38, pl. v. fig. 1; Steindachn. Sitzb. Ak. Wien, lx. i. 1870, p. 970; Sauvage, N. Arch. Mus. (2) iii. 1880, p. 35; Steindachn. Notes Leyd. Mus. xvi. 1894, p. 47.

Chromichthys elongatus, Guichen. in A. Dum. Arch. Mus. x. 1859, p. 257, pl. xxii. fig. 3.

Hemichromis auritus, Gill, Proc. Ac. Philad. 1862, p. 135; Günth. l. c. p. 275.

Hemichromis leiguardii, Capello, Jorn. Sc. Lisb. iv. 1872, p. 85.

Hemichromis desquezii, Rochebrune, Bull. Soc. Philom. (7) iv. 1880, p. 168, and Act. Soc. Linn. Bord. vi. 1882, pl. v. fig. 6.

Middle teeth distinctly enlarged, canine-like; a regular series of very small præmaxillary teeth some distance behind the marginal one.¹ Depth of body equal to or a little greater than length of head, $2\frac{1}{2}$ to 3 times in total length. Snout with straight or concave upper profile, longer than the eye; in the adult diameter of eye contained 4 to $5\frac{1}{2}$ times in length of head, and $1\frac{1}{3}$ to $1\frac{3}{4}$ in interorbital width; maxillary not extending to below anterior border of eye; 4 or 5 series of scales on the cheek; large scales on the opercle. Gill-rakers short, some hammer-shaped, 6–10 on lower part of anterior arch. Dorsal XIII–XV 11–13; spines increasing in length to the last, which measures $\frac{1}{3}$ to $\frac{2}{5}$ length of head and $\frac{2}{5}$ to $\frac{3}{5}$ longest soft rays. Pectoral $\frac{2}{5}$ length of head. Outer ventral rays produced into filaments, reaching the vent or the anal spines. Anal III 8–10; third spine longest, $\frac{1}{3}$ to $\frac{2}{5}$ length of head, as long as middle dorsal spines. Caudal truncate or rounded. Caudal peduncle nearly as long as deep. Scales 29–32 $\frac{3-3\frac{1}{2}}{10}$; lat. l. $\frac{15-19}{10-14}$. Olive or brown, with a black or blue spot on the opercle and five more or less distinct dark vertical bars which may be reduced to a series of as many blackish blotches along the side, the last at base of caudal; young with less distinct bars between the principal ones; fins brown or blackish; dorsal and anal sometimes with round whitish spots between the rays; longitudinal series of pearl-colour or brown spots, one to each scale, may be present on the sides.

Total length 200 millim.

The very numerous specimens in the British Museum are from the following localities:—Sierra Leone, Lagos, Old Calabar, Gaboon, Ogowe, Upper and Lower Congo.

2. *HEMICHROMIS BIMACULATUS*.

Hemichromis bimaculatus, Gill, Proc. Ac. Philad. 1862, p. 137 Günth. Cat. iv. p. 275 (1862); Steindachn. Sitzb. Ak. Wien, lx. i. 1870, p. 972, pl. i. fig. 5; Sauvage, N. Arch. Mus. (2) iii. 1880,

¹ I have examined a large series of specimens, ranging from 40 to 200 millim. total length, and find the character of the dentition very constant, contrary to what Steindachner was inclined to believe (Sitzb. Ak. Wien, lx. i. 1870, p. 974).

p. 35, pl. ii. fig. 1; Steindachn. Notes Leyd. Mus. xvi. 1894, p. 49; Günth. Ann. & Mag. N. H. (6) xvii. 1896, p. 272.

Hemichromis guttatus, Günth. Cat. iv. p. 275.

Hemichromis letourneuxii, Sauvage, Bull. Soc. Philom. (7) iv. 1880, p. 212.

Hemichromis saharae, Sauvage, l. c. p. 226.

*Hemichromis rolandi*¹, Sauvage, op. cit. v. 1881, p. 103.

Middle teeth but feebly enlarged; inner præmaxillary teeth absent or reduced to a few, irregularly disposed. Depth of body equal to or a little greater than length of head, $2\frac{1}{2}$ to 3 times in total length. Snout with straight or convex upper profile, as long as the eye, which is contained $3\frac{2}{3}$ to 4 times in length of head and equals or is a little less than interorbital width; maxillary extending to below anterior border of eye or not quite so far; 3 or 4 (rarely 5) series of scales on the cheek; large scales on the opercle, which terminates in a rounded, stiff, scaleless lobe. Gill-rakers short, 8 to 10 on lower part of anterior arch. Dorsal XIII-XV 10-12; spines increasing in length to the last, which measures about $\frac{2}{5}$ to $\frac{1}{2}$ length of head and $\frac{1}{2}$ to $\frac{3}{5}$ longest soft rays. Pectoral $\frac{3}{5}$ to $\frac{2}{3}$ length of head. Outer ventral rays produced into short filaments, reaching vent, origin of anal, or even a little beyond. Anal III 7-9; third spine longest, as long as median dorsal spines. Caudal rounded. Caudal peduncle a little deeper than long. Scales 25-28 $\frac{2\frac{1}{2}-3}{9-10}$; lat. l. $\frac{15-19}{7-10}$. Yellowish, reddish, or brown, with or without rather indistinct dark vertical bars and two or three round blackish spots, the first (sometimes blue) on the opercle, the second below middle of dorsal fin and between the two lateral lines, the third, if present, at base of caudal; sides sometimes with series of pearl-coloured spots; cheeks, opercles, and fins sometimes with round dark brown spots; outer ventral rays brown or blackish.

Total length 120 millim.

This species has a wide distribution. I have examined specimens from Lake Mareotis, Lower Egypt (*H. letourneuxii*, Sauv.), the Algerian Sahara (*H. saharae*, Sauv., *H. rolandi*, Sauv.), Sierra Leone, Old Calabar, Gaboon, the Ogowe, and the Congo.

No reliance can be placed on the locality (Cape of Good Hope) affixed to the types of *H. guttatus*, Gthr., which were purchased of a dealer as being from "Ceylon."

3. HEMICHROMIS ? ANGOLENSIS.

Hemichromis angolensis, Steindachn. Mem. Ac. Lisb. (3) iii. pt. ii. 1865, no. 10.

Teeth in two rows, outer longest. Depth of body a little greater than length of head, not 3 times in total length. Snout with concave upper profile; diameter of eye 6 times in length of head; 6 or 7 series of scales on the cheek; large scales on the

¹ Should be spelt "*rollandi*," the species being named after the distinguished French engineer G. Rolland.

opercle. Dorsal XV 11; spines increasing in length to the last, which is a little less than half length of longest soft rays. Lat. l. $\frac{21}{10-11}$. Brown; soft dorsal, anal, and caudal with purplish brown spots; a large blackish opercular spot.

Total length 200 millim.

Angola.

This species is known to me only from Steindachner's very imperfect description. Its allocation to the genus *Hemichromis* s. s. is therefore doubtful.

3. PARATILAPIA.

Paratilapia, Bleeker, Versl. Ak. Amsterd. ii. 1868, p. 307.

Paracara, Bleeker, Versl. Ak. Amsterd. xii. 1878, p. 193.

Hemichromis, part., Pfeffer, Thierw. O.-Afr., Fische, p. 19 (1896).

Body short or more or less elongate; scales cycloid or ctenoid. Two or more series of conical teeth in the jaws. Maxillary exposed. Dorsal with 10 to 18 spines, anal with 3. Vertebrae 27-38 (13+14 in *P. polleni*, 15+13 in *P. sacra*, 17+19 in *P. robusta*, 19+19 in *P. longiceps*).

Numerous species, from Syria, Tropical and South Africa, and Madagascar.

Synopsis of the Species.

I. Dorsal with X-XII (rarely XIII) spines; pectoral $\frac{3}{2}$ length of head.

Dorsal with 11-12 soft rays, which are much longer than longest spines; maxillary extending to below anterior third of eye

1. *polleni*, Blkr.

Dorsal with 10 soft rays, which are but little longer than longest spines; anal spines longer and stronger than dorsals

2. *bleekeri*, Sauv.

Dorsal with 9-10 soft rays which are much longer than longest spines; maxillary extending to below anterior border of eye

3. *typus*, Blkr.

II. Dorsal with XIII-XIV spines.

4 or 5 series of scales on the cheek; scales 30-32 $\frac{3-4}{13-15}$; pectoral at least $\frac{3}{2}$ length of head

4. *sacra*, Gthr.

3 series of scales on the cheek; scales 32 $\frac{6}{12}$; pectoral not $\frac{3}{2}$ length of head

5. *longirostris*, Hilg.

3 series of scales on the cheek; scales 26-28 $\frac{2\frac{1}{2}-3}{10}$; pectoral $\frac{3}{2}$ length of head

6. *moffati*, Cast.

III. Dorsal with XV-XVIII spines.

A. 6-9 series of scales on the cheek.

1. Dorsal with 15 or 16 soft rays; 2 or 3 series of teeth in the jaws; pectoral $\frac{3}{2}$ to $\frac{3}{4}$ length of head

7. *robusta*, Gthr.

2. Dorsal with 8 or 9 soft rays.

3 or 4 series of teeth in the jaws; pectoral about $\frac{3}{2}$ length of head

8. *cavifrons*, Hilg.

- 7-9 series of teeth in the jaws; pectoral as long as head 9. *retrodens*, Hilg.
- B. 2-5 series of scales on the cheek; dorsal with 8-12 soft rays.
1. Scales 28-32 in a longitudinal series.
- a. Pectoral $\frac{2}{3}$ to $\frac{3}{4}$ length of head.
- Sc. 29-32 $\frac{3}{10}$; maxillary not extending to below eye... 10. *afra*, Gthr.
- Sc. 28 $\frac{4\frac{1}{2}}{10}$; maxillary extending to below anterior border of eye 11. *bloyeti*, Sauv.
- Sc. 31 $\frac{7}{14}$; maxillary extending to below eye 12. *serranus*, Pfeff.
- b. Pectoral as long as head.
- Sc. 30 $\frac{3}{10}$; maxillary not extending to below eye 13. *schwebischi*, Sauv.
2. Scales 32-36 in a longitudinal series.
- a. Caudal peduncle slightly longer than deep.
- Sc. 32-34 $\frac{3\frac{1}{2}-4}{12-13}$; pectoral $\frac{2}{3}$ length of head..... 14. *modesta*, Gthr.
- Sc. 35-36 $\frac{4-5}{13}$; pectoral $\frac{1}{2}$ length of head 15. *livingstonii*, Gthr.
- b. Caudal peduncle $1\frac{1}{2}$ -2 as long as deep.
- Sc. 33-36 $\frac{3}{10-11}$; pectoral as long as head 16. *intermedia*, Gthr.
- Sc. 35-36 $\frac{3}{12-13}$; pectoral $\frac{2}{3}$ length of head 17. *dimidiata*, Gthr.
3. Sc. 40-41 $\frac{3\frac{1}{2}}{11}$ 18. *longiceps*, Gthr.

1. PARATILAPIA POLLENI.

Paratilapia polleni, Bleek. Versl. Ak. Amsterd. ii. 1868, p. 307; Bleek. & Pollen, Poiss. Madag. p. 10, pl. v. fig. 2 (1875); Steindachn. Sitzb. Ak. Wien, 1880, p. 247; Sauvage, Hist. Madag., Poiss. p. 443, pl. xlv. fig. 2 (1891).

Teeth in 4 or 5 series. Depth of body 2 to $2\frac{1}{3}$ times in total length, length of head $2\frac{1}{2}$ to $2\frac{4}{5}$ times. Snout with straight or concave upper profile, as long as the eye in the young, $1\frac{2}{3}$ in the adult; diameter of eye 4 to 6 times in length of head; interorbital width equal to diameter of eye in the young, $1\frac{2}{3}$ in the adult; maxillary extending to below anterior third of eye; 4 to 6 series of scales on the cheek; large scales on the opercle. Gill-rakers moderately long, 7 to 10 on lower part of anterior arch. Dorsal X-XII 11-12; spines increasing in length to the last, which measures $\frac{1}{3}$ to $\frac{2}{3}$ length of head, and $\frac{1}{3}$ to $\frac{2}{3}$ length of longest soft rays. Pectoral $\frac{2}{5}$ length of head. Ventral reaching vent or anal. Anal III 8-11; third spine a little shorter but stouter than longest dorsal spine. Caudal rounded. Caudal peduncle nearly as long as deep. Scales finely denticulate on the border, 28-30 $\frac{3\frac{1}{2}-4\frac{1}{2}}{12-13}$; lat. 1. $\frac{14-17}{10-13}$. Dark brown or blackish, uniform or with bluish-white spots.

Total length 205 millim.

Madagascar.

2. PARATILAPIA BLEEKERI.

Paratilapia bleekeri, Sauvage, Hist. Madag., Poiss. p. 444, pl. xliv. fig. 1 (1891)¹.

Closely allied to *P. polleni*, from which it differs in the shorter soft rays, the dorsal and anal being hardly longer than the longest spines. Ventral not reaching anal. Dorsal XII-XIII 10. Anal III 9. 28 scales in a longitudinal series. Brownish, the centre of each scale blue; blue spots on the anal and usually on the soft dorsal and the caudal.

Total length 110 millim.

Near Antananarivo, Madagascar.

3. PARATILAPIA TYPUS.

Paracara typus, Bleek. Versl. Ak. Amsterd. xii. 1878, p. 193, pl. iii. fig. 3; Sauvage, Hist. Madag., Poiss. p. 438, pl. 44^A. fig. 8, and C, fig. 11 (1891).

Teeth in 3 or 4 series. Depth of body $2\frac{1}{2}$ to $2\frac{3}{4}$ times in total length, length of head $2\frac{3}{4}$ times. Snout a little longer than the diameter of the eye, which is nearly 4 times in length of head; maxillary extending to below anterior border of eye; 5 or 6 series of scales on the cheek. Dorsal XII 9-10. Anal III 8-9. Pectoral $\frac{3}{5}$ length of head. Ventral not reaching anal. Caudal rounded. Caudal peduncle as long as deep or a little longer than deep. Scales smooth on the anterior part of the body, ctenoid posteriorly, 30 $\frac{4}{12}$; lat. 1. $\frac{18-20}{13-15}$. Greenish, with more or less distinct dark cross-bars; a blackish opercular spot.

Total length 120 millim.

Madagascar.

4. PARATILAPIA SACRA.

Hemichromis sacra, Günth. Proc. Zool. Soc. 1864, p. 493; Lortet, Arch. Mus. Lyon, iii. 1883, p. 148, pl. x. fig. 1; Tristram, Faun. Palest. p. 168, pl. xviii. fig. 2 (1884).

Teeth in 3 or 4 series in both jaws, outer largest. Lower jaw projecting. Depth of body $2\frac{2}{3}$ to 3 times in total length, length of head $2\frac{1}{2}$ to $2\frac{2}{3}$ times. Snout with convex upper profile, nearly twice as long as the eye, which is 5 to 6 times in length of head and $1\frac{1}{4}$ to $1\frac{1}{2}$ in interorbital width; maxillary not extending to below anterior border of eye; 4 or 5 series of scales on the cheek; large scales on the opercle. Gill-rakers short, 8-11 on lower part of anterior arch. Dorsal XIV 10-11; spines increasing in length to the last, which measures about $\frac{1}{3}$ length of head and $\frac{2}{3}$ longest soft rays. Pectoral $\frac{3}{4}$ to $\frac{7}{8}$ length of head. Ventral not reaching vent. Anal III 8-9; third spine longest and strongest, nearly as long as longest dorsal spine. Caudal truncate. Caudal peduncle as long as deep. Scales smooth, 30-32 $\frac{3-4}{13-15}$;

¹ I have been unable to find a description of this species in the Bull. Soc. Philom. vi. 1882, p. 174, to which Sauvage refers in the work here quoted.

lat. l. $\frac{13-20}{9-14}$. Greenish olive above, silvery beneath; fins greyish, unspotted.

Total length 240 millim.

Sea of Galilee.

5. PARATILAPIA LONGIROSTRIS.

Paratilapia? longirostris, Hilgendorf. Sitzb. Ges. nat. Fr. Berl. 1888, p. 77.

Hemichromis longirostris, Pfeffer, Thierw. O.-Afr., Fische, p. 20 (1896).

Teeth in 3 series in both jaws, outer largest. Lower jaw projecting. Depth of body a little less than length of head, $3\frac{2}{5}$ times in total length. Snout with straight upper profile, $1\frac{2}{3}$ diameter of eye, which is 5 times in length of head, and equals interorbital width; maxillary not extending to below anterior border of eye; 3 series of scales on the cheek; large scales on the opercle. Larger gill-rakers somewhat Y-shaped. Dorsal XIII 9; middle spines $3\frac{1}{2}$ in length of head. Pectoral moderately long. Ventral not quite reaching vent. Anal III 8. Caudal almost entirely scaly. Caudal peduncle twice as long as deep. Scales finely denticulate on the border, $32\frac{6}{12}$. Brown above, silvery beneath; a dark spot below and in front of the eye, continued as a rather indistinct streak to the end of the snout; fins greyish or colourless.

Total length 125 millim.

Victoria Nyanza.

6. PARATILAPIA MOFFATI.

Chromys moffati, Castelnau, Poiss. Afr. Austr. p. 16 (1861).

Teeth in 3 series in both jaws, outer largest but small. Lower jaw projecting. Depth of body equal to or a little greater than length of head, $2\frac{2}{3}$ to $2\frac{4}{5}$ times in total length. Snout with convex upper profile, $1\frac{1}{3}$ diameter of eye, which is 4 times in length of head and equals interorbital width; maxillary extending to below anterior border of eye; 3 series of scales on the cheek; opercle almost entirely naked. Gill-rakers short, 7 or 8 on lower part of anterior arch. Dorsal XIII 10; spines increasing in length to the last, which measures $\frac{1}{3}$ length of head and $\frac{2}{5}$ longest soft rays. Pectoral $\frac{2}{3}$ length of head. Ventral reaching vent. Anal III 8; third spine a little shorter than longest dorsal spine. Caudal rounded. Caudal peduncle as long as deep. Scales finely denticulate on the border, 26-28 $\frac{2\frac{1}{2}-3}{10}$; lat. l. $\frac{10-15}{8-9}$. Olive; a blackish opercular spot; membrane between dorsal spines bordered with black; ventrals black.

Total length 95 millim.

Pretoria, Transvaal. Three specimens, presented by Mr. W. L. Distant. The types described by Castelnau came from the Kuruman R., a tributary of the Orange R.

7. PARATILAPIA ROBUSTA.

Hemichromis robustus, Günth. Proc. Zool. Soc. 1864, p. 312.

Hemichromis jallæ, Bouleng. Boll. Mus. Torin. xi. 1896, no. 260.

2 or 3 series of teeth in the upper jaw, outer largest; 2 series in the lower jaw, the inner short and composed of a small number of small teeth. Lower jaw projecting. Depth of body equal to length of head, 3 times in total length. Snout with straight or slightly convex upper profile, twice as long as the eye in the adult; diameter of eye 5 to $5\frac{2}{3}$ times in length of head, a little less than interorbital width; maxillary extending to below anterior border of eye or a little beyond; 7 to 9 series of scales on the cheek; large scales on the opercle. Gill-rakers short, the larger ones anvil-shaped, with one or two erect cusps, 10 to 12 on lower part of anterior arch. Dorsal XV–XVI 14–15; spines increasing in length to the last, which measures $\frac{1}{4}$ to $\frac{1}{3}$ length of head, and about $\frac{1}{2}$ longest soft rays. Pectoral nearly $\frac{2}{3}$ length of head. Ventral not reaching vent. Anal III 10–11; third spine longest, as long as middle dorsal spines. Caudal truncate. Caudal peduncle a little longer than deep. Scales finely denticulate on the edge, mostly cycloid in the young, 37–39 $\frac{5-6}{13-15}$; lat. l. $\frac{21-24}{15-17}$. Brown above, silvery beneath, with two dark brown or black lateral stripes, the upper running above the upper lateral line, the lower from the opercle to the base of the caudal fin; fins greyish, dorsal and caudal with round blackish spots between the rays.

Total length 300 millim.

Lake Nyassa and Upper Shiré River; Upper Zambesi.

Entertaining some doubts as to the distinction of *Hemichromis jallæ*, a species established by me on a single small specimen from Kazungula, Upper Zambesi, at a time when I was not acquainted with the young of *H. robustus*, I have, through the kindness of Prof. Camerano, re-examined the type preserved in the Turin Museum. The result of my examination appears in the above synonymy.

8. PARATILAPIA CAVIFRONS.

Paratilapia? cavifrons, Hilgend. Sitzb. Ges. nat. Fr. Berl. 1888, p. 77.

Hemichromis cavifrons, Pfeffer, Thierw. O.-Afr., Fische, p. 21 (1896).

Teeth in 4 series in the upper jaw, in 3 in the lower, outer largest. Lower jaw projecting. Depth of body a little greater than length of head, $3\frac{1}{4}$ times in total length. Snout with concave upper profile, twice as long as the diameter of the eye, which is $5\frac{1}{2}$ times in length of head, and measures nearly $\frac{1}{2}$ interorbital width; maxillary not extending to below anterior border of eye; 7 series of scales on the cheek; large scales on the opercle. Larger gill-rakers expanded and denticulate. Dorsal XVI 8; spines

increasing in length to the eighth, which measures $1\frac{2}{3}$ diameter of eye; longest soft rays not $\frac{1}{2}$ length of head. Pectoral moderately long. Ventral reaching origin of anal. Anal III 9. Caudal almost entirely scaly. Caudal peduncle as long as deep. Scales finely denticulate on the border, $32\frac{9}{14}$. Pale greenish grey, darker on the back, dotted all over with small brown spots, one to each scale; cheeks reddish; a large bluish-black opercular spot; dorsal with rather irregular dark streaks; caudal spotted between the rays.

Total length 160 millim.

Victoria Nyanza.

9. PARATILAPIA RETRODENS.

Paratilapia? *retrodens*, Hilgend. Sitzb. Ges. nat. Fr. Berl. 1888, p. 76.

Hemichromis retrodens, Pfeffer, Thierw. O.-Afr., Fische, p. 19 (1896).

Teeth in broad bands in both jaws, in 7 series in the upper, in 9 in the lower, outer series largest. Depth of body equal to length of head, $2\frac{7}{8}$ times in total length. Snout with convex upper profile, slightly longer than the diameter of the eye, which is somewhat more than 4 times in length of head and $1\frac{1}{2}$ in interorbital width; maxillary extending to below anterior border of eye; 6 series of scales on the cheek; large scales on the opercle. Larger gill-rakers expanded and denticulate. Dorsal XVI 9; middle spines $2\frac{3}{5}$ in length of head; soft rays long. Pectoral and ventral long and pointed, reaching beyond middle of base of anal. Anal III 9. Caudal almost entirely scaly. Caudal peduncle $1\frac{1}{3}$ as deep as long. Scales finely denticulate on the border, $30\frac{7}{11}$. Reddish grey, with a broad dark brown stripe from the gill-opening to the base of the caudal, and another, less developed, from the nape along the base of the dorsal; a black opercular spot; breast and belly with dark spots, one to each scale; two large bluish-white ocelli close together on the posterior part of the anal; dorsal and caudal grey; pectorals greyish; ventrals black.

Total length 140 millim.

Victoria Nyanza.

10. PARATILAPIA AFRA.

Hemichromis afer, Günth. Proc. Zool. Soc. 1893, p. 626, pl. lvii. fig. B.

Teeth in 3 series in both jaws, outer largest. Depth of body nearly equal to length of head, 3 times in total length. Snout with convex upper profile, as long as the eye, which is $3\frac{1}{2}$ times in length of head, and equals or slightly exceeds interorbital width; maxillary not extending to below anterior border of eye; 3 or 4 series of scales on the cheek; large scales on the opercle. Gill-rakers short, 13 or 14 on lower part of anterior arch, the largest T-shaped. Dorsal XVII 8; spines increasing in length to the last, which measures $\frac{2}{5}$ length of head and about $\frac{3}{5}$ longest soft rays. Pectoral $\frac{3}{4}$ length of head. Ventral reaching vent.

Anal III 6-7; third spine longest, as long as longest dorsal. Caudal rounded. Caudal peduncle slightly longer than deep. Scales finely denticulate on the border, 29-32 $\frac{3}{10}$; lat. l. $\frac{21-22}{9-12}$. Dark brown; fins blackish.

Total length 93 millim.

Lake Nyassa.

11. PARATILAPIA BLOYETI.

Hemichromis bloyeti, Sauvage, Bull. Soc. Philom. (7) vii. 1883, p. 159.

Hemichromis gigliolii, Pfeffer, Thierw. O.-Afr., Fische, p. 24 (1896).

2 or 3 series of minute teeth behind the marginal ones in both jaws. Depth of body equal to length of head, not quite 3 times in total length. Snout with straight upper profile, a little longer than the diameter of the eye, which is somewhat more than 4 times in length of head and a little less than interorbital width; maxillary extending to below anterior border of eye; 4 series of scales on the cheek; large scales on the opercle. Gill-rakers short, 7 on lower part of anterior arch, the larger T-shaped. Dorsal XVI 8-9; spines increasing in size, the last $\frac{1}{2}$ in length of head and $\frac{2}{3}$ longest soft rays. Pectoral $\frac{2}{3}$ length of head. Ventral nearly reaching anal. Anal III 7-8. Caudal peduncle as long as deep. Scales finely denticulate on the border, 28 $\frac{4\frac{1}{2}}{10}$. Greenish grey; a black opercular spot; a trace of a dark streak on the caudal peduncle; small dark streaks on the dorsal and caudal fins and at the base of the anal.

Total length 90 millim.

East Africa.

I have examined one of the types of the species, from Kandoa. *H. gigliolii*, which, from the description, I regard as identical, is from the Kingani River.

12. PARATILAPIA SERRANUS.

Hemichromis serranus, Pfeffer, Thierw. O.-Afr., Fische, p. 23 (1896).

Teeth in 3 series in the upper jaw, in 2 in the lower, outer largest. Lower jaw projecting. Depth of body a little less than length of head, $3\frac{1}{2}$ times in total length. Snout with straight upper profile, slightly longer than diameter of eye, which is 4 times in length of head and equals interorbital width; maxillary extending to below eye; 4 series of scales on the cheek; opercle scaleless. Larger gill-rakers T-shaped. Dorsal XVI 9; spines increasing in length to the last, which is $2\frac{4}{7}$ times in length of head. Pectoral and ventral pointed, reaching anal. Anal III 9. Scales faintly denticulate on the border, $31\frac{7}{14}$. Brownish above, whitish beneath; two black stripes on each side, the upper from the nape along the base of the dorsal, the lower from the gill-

opening to the caudal ; a large blackish opercular spot ; fins grey, unspotted.

Total length 110 millim.

Bukoba, Victoria Nyanza, German East Africa.

13. PARATILAPIA SCHWEBISCHI.

Hemichromis schwebischi, Sauvage, Bull. Soc. Zool. France, 1884, p. 198, pl. v. fig. 2.

Teeth in broad bands, in 4 or 5 series in both jaws. Lower jaw not projecting. Depth of body greater than length of head, $2\frac{1}{3}$ times in total length. Snout with concave upper profile, a little more than twice as long as diameter of eye, which is $5\frac{1}{2}$ times in length of head and $\frac{1}{2}$ interorbital width ; maxillary extending a little beyond the vertical of the nostril ; 3 series of scales on the cheek ; opercle with large scales. Gill-rakers rather short, lanceolate, 22 on lower part of anterior arch. Dorsal XV 11 ; spines increasing in length to the last, which is a little less than $\frac{1}{2}$ as long as the head and $\frac{2}{5}$ length of longest soft rays. Pectoral as long as head. Ventral reaching anal. Anal III 9. Caudal slightly emarginate. Caudal peduncle as long as deep. Scales rough, finely denticulate, $30\frac{3}{10}$; lat. 1. $\frac{2}{12}$. Olive ; scales on posterior part of body golden in the centre ; spinous dorsal marbled with purplish ; posterior part of soft dorsal and caudal with blue spots ; ventrals and pectorals colourless.

Total length 320 millim.

Upper Ogowe.

The diagnosis is drawn up from the type specimen preserved in the Paris Museum.

14. PARATILAPIA MODESTA.

Hemichromis modestus, Günth. Proc. Zool. Soc. 1893, p. 625, pl. lvii. fig. A.

Teeth in 3 or 4 series in both jaws, outer largest. Lower jaw projecting. Depth of body equal to or a little less than length of head, $2\frac{2}{3}$ to 3 times in total length. Snout with straight or slightly convex upper profile, $1\frac{1}{2}$ to $1\frac{2}{3}$ as long as the eye, which is 4 to $4\frac{1}{2}$ times in length of head and $\frac{2}{3}$ to $\frac{3}{4}$ interorbital width ; maxillary extending to below anterior border of eye or not quite so far ; 3 series of scales on the cheek ; large scales on the opercle. Gill-rakers short, a few T-shaped, 10 to 12 on lower part of anterior arch. Dorsal XVI 10-11 ; spines increasing in length to the last, which measures $\frac{1}{3}$ to $\frac{2}{5}$ length of head, and $\frac{3}{5}$ longest soft rays. Pectoral $\frac{2}{3}$ length of head. Ventral reaching origin of anal. Anal III 8-9 ; third spine longest, a little shorter than last dorsal spine. Caudal rounded. Caudal peduncle slightly longer than deep. Scales finely denticulate on the border, $32-34\frac{3\frac{1}{2}-4}{12-13}$; lat. 1. $\frac{21-24}{13-14}$. Uniform dark brown, fins blackish.

Total length 200 millim.

Lake Nyassa and Upper Shiré River.

15. PARATILAPIA LIVINGSTONII.

Hemichromis livingstonii, Günth. Proc. Zool. Soc. 1893, p. 625, pl. lvi. fig. B.

Teeth in 4 or 5 series in both jaws, outer largest. Depth of body equal to length of head, nearly 3 times in total length. Snout with straight upper profile, $1\frac{1}{2}$ to 2 times diameter of eye, which is 4 to 5 times in length of head and $1\frac{1}{4}$ to $1\frac{1}{2}$ in interorbital width; maxillary not extending to below anterior border of eye; 4 series of scales on the cheek; large scales on the opercle. Gill-rakers short, 11 or 12 on lower part of anterior arch. Dorsal XVI 10–11; spines increasing in length to the last, which measures $\frac{1}{3}$ to $\frac{2}{5}$ length of head and $\frac{3}{4}$ longest soft rays. Pectoral $\frac{4}{5}$ length of head. Ventral reaching vent. Anal III 9; third spine as long as longest dorsal. Caudal truncate. Caudal peduncle slightly longer than deep. Scales finely denticulate on the border, 35–36 $\frac{4-5}{13}$; lat. l. $\frac{23}{14-15}$. Silvery, largely and irregularly marbled with black.

Total length 180 millim.

Lake Nyassa and Upper Shiré River.

16. PARATILAPIA INTERMEDIA.

Hemichromis intermedius, Günth. Proc. Zool. Soc. 1864, p. 312.

Teeth small, in 2 or 3 series in each jaw, outer largest. Depth of body $2\frac{1}{2}$ to $2\frac{3}{4}$ times in total length, length of head 3 to $3\frac{1}{2}$ times. Snout with straight upper profile, $1\frac{1}{3}$ to $1\frac{1}{2}$ diameter of eye (in the adult), which is 4 times in length of head and nearly equal to or a little greater than interorbital width; maxillary not extending to below anterior border of eye; 2 or 3 series of scales on the cheek; large scales on the opercle. Gill-rakers rather long, close-set, 20 to 27 on lower part of anterior arch, a few of the larger ones sometimes Y-shaped. Dorsal XV–XVIII 9–11; spines increasing in length to the last, which measures little less than $\frac{1}{2}$ length of head, and $\frac{1}{2}$ to $\frac{4}{5}$ length of longest soft rays. Pectoral as long as head. Ventral reaching vent, or produced to the anterior soft rays of anal. Anal III 9–10; third spine strongest, as long as fifth dorsal spine. Caudal more or less extensively scaly, emarginate. Caudal peduncle $1\frac{1}{2}$ as long as deep. Scales very finely denticulate on the edge, 33–36 $\frac{3}{10-11}$; lat. l. $\frac{20-30}{14-18}$. Pale olive to dark brown, with a more or less distinct blackish spot under the lateral line, below middle of spinous dorsal, and another at base of caudal; dorsal and anal dark brown, often with a broad whitish border, with or without round whitish spots; pectoral whitish, ventral dark brown.

Total length 180 millim.

Lake Nyassa and Upper Shiré River.

17. PARATILAPIA DIMIDIATA.

Hemichromis dimidiatus, Günth. Proc. Zool. Soc. 1864, p. 313.

Teeth in 3 series in both jaws, the outer series composed of

long teeth rather wide apart. Lower jaw projecting. Depth of body $3\frac{1}{2}$ times in total length, length of head 3 times. Snout with convex upper profile, twice as long as the eye; diameter of eye 5 to $5\frac{1}{2}$ times in length of head, $1\frac{1}{3}$ in interorbital width; maxillary not extending to below anterior border of eyes; 4 or 5 series of scales on the cheek; large scales on the opercle. Gill-rakers short, 11 on lower part of anterior arch. Dorsal XVI 10-11; spines increasing in length to the last, which measures $\frac{1}{3}$ length of head and about $\frac{2}{3}$ longest soft rays. Pectoral $\frac{2}{3}$ length of head. Ventral not reaching vent. Anal III 10-11; third spine longest, as long as middle dorsal spines. Caudal very slightly emarginate. Caudal peduncle $1\frac{1}{3}$ to 2 times as long as deep. Scales not denticulate, 35-36 $\frac{3}{12-13}$; lat. l. $\frac{22}{15}$. Olive-brown above, silvery beneath; a blackish stripe from above the pectoral to the base of the caudal; fins whitish, unspotted.

Total length 220 millim.

Lake Nyassa and Upper Shiré River.

18. PARATILAPIA LONGICEPS.

Hemichromis longiceps, Günth. Proc. Zool. Soc. 1864, p. 313.

Teeth in 2 series in both jaws, outer largest, long and sharp and rather wide apart. Depth of body 4 times in total length, length of head $2\frac{2}{3}$ to 3 times. Snout long and strongly compressed, with convex upper profile; diameter of eye 2 to $2\frac{1}{2}$ times in length of snout, 5 to $5\frac{1}{2}$ times in length of head, $1\frac{1}{2}$ in interorbital width; maxillary widely separated from the vertical of the eye; 3 series of scales on the cheek; opercle partially naked. Gill-rakers rather long, about $\frac{1}{2}$ length of gill-fringes, 17 on lower part of anterior arch. Dorsal XVII-XVIII 12; spines increasing in length to the last, which measures $\frac{1}{4}$ length of head. Pectoral $\frac{3}{5}$ length of head. Ventral not reaching vent. Anal III 9-10; third spine longest, as long as last dorsal. Caudal slightly emarginate. Caudal peduncle nearly twice as long as deep. Scales finely denticulate on the border, 40-41 $\frac{3\frac{1}{2}}{11}$; lat. l. $\frac{24-28}{18-24}$. Silvery, blackish on the back; a blackish opercular spot; fins greyish, immaculate.

Total length 240 millim.

Lake Nyassa and Upper Shiré River.

Three of the "*Chromis*" described by Castelnau from Lake Ngami very probably belong to this genus and appear to be based on individual variations of a single species:—

PARATILAPIA THUMBERGII.

Chromys thumbergi, Castelnau, Poiss. Afr. Austr. p. 13 (1861).

Chromys ngamensis, Casteln. l. c.

Chromys livingstonii, Casteln. l. c.

Teeth in 3 or 4 series. Body rather elongate. Dorsal XVII 13-14. Anal III 9. Golden, dark green, or blackish, with or

without red borders to the scales; dorsal grey, with round black spots or red dots or edged with yellow; anal grey, with or without green spots, edged with yellow or red.

Total length 330 millim.

Lake Ngami.

4. PELMATOCHROMIS.

Pelmatochromis, Steindachner, Notes Leyd. Mus. xvi. 1894, p. 40.

Characters of *Paratilapia*, with the addition of a much-developed cushion-like papillose pad of mucous membrane on each side of the palate, close to the upper part of the branchial arches¹.

West Africa; Congo.

Synopsis of the Species.

- I. 6 or 7 series of teeth in the jaws; dorsal XIV 21-12; pectoral nearly as long as head; scales very finely denticulate on the edge, 26-27 $\frac{3-3\frac{1}{2}}{8-10}$ 1. *buettikoferi*, Sldr.
- II. 2 or 3 series of teeth in the jaws.
- A. Lower lateral line at least nearly as long as upper; pectoral as long as head.
- Dorsal XIII-XIV 17; scales finely denticulate, 40 $\frac{6}{3}$; lat. l. $\frac{23-29}{26-27}$ 2. *jentinki*, Sldr.
- Dorsal XVI 12; scales cycloid, 32 $\frac{4}{2}$; lat. l. $\frac{23-24}{28-29}$... 3. *lateralis*, Blgr.
- B. Lower lateral line short, confined to the caudal region; scales cycloid.
1. Pectoral as long as head; dorsal XIII 11; scales 30 $\frac{4}{11}$; lat. l. $\frac{21}{10}$ 4. *congicus*, Blgr.
2. Pectoral $\frac{2}{3}$ length of head.
- Dorsal XIV 11; scales 32 $\frac{3\frac{1}{2}}{9}$; lat. l. $\frac{21}{14}$; maxillary not extending to below anterior border of eye 5. *welwitschi*, Blgr.
- Dorsal XVI 9; scales 31 $\frac{2\frac{1}{2}}{10}$; lat. l. $\frac{20}{12}$; maxillary not extending to below anterior border of eye 6. *guentheri*, Sauv.
- Dorsal XIV-XVI 8-9; scales 26-28 $\frac{2-2\frac{1}{2}}{11}$; lat. l. $\frac{16-18}{5-9}$; maxillary extending to below anterior border of eye 7. *subocellatus*, Gthr.

1. PELMATOCHROMIS BUETTIKOFERI.

Paratilapia (Pelmatochromis) buettikoferi, Steindachn. Notes Leyd. Mus. xvi. 1894, p. 40.

Teeth in broad bands, in about 7 series in the upper jaw, in 6 in

¹ This gives the impression, on a superficial glance under the opercle, of a lobe to the outer branchial arch, as in *Geophagus*. A similar pad is more or less developed in *Tilapia*, especially in *T. oligacanthus*, Blkr., which has for this reason been raised to generic rank (*Ptychochromis*, Sldr.).

the lower. Depth of body 2 to $2\frac{1}{4}$ times in total length, length of head $2\frac{2}{3}$ to $2\frac{3}{4}$. Snout a little longer than the diameter of the eye, which is contained 3 to $3\frac{1}{4}$ times in length of head and measures a little more than interorbital width; maxillary extending to below anterior border of eye; 3 or 4 rows of scales on the cheek; very large scales on the opercle. Gill-rakers long and slender, 6-9 on lower part of anterior arch. Dorsal XIV 11-12; spines increasing in length to the seventh or to the last, which is $2\frac{1}{5}$ to $2\frac{2}{5}$ times in length of head, and about $\frac{3}{5}$ length of longest soft rays. Pectoral nearly as long as head. Outer ventral ray produced, filiform, reaching third anal spine. Anal III 8; third spine nearly as long as but thicker than longest dorsal spine. Caudal emarginate. Scales very finely denticulate on the edge, 26-27 $\frac{3-3\frac{1}{2}}{8-10}$; lat. l. $\frac{17-19}{9-11}$. Body with five ill-defined brown bars; a large steel-blue opercular spot; dorsal and caudal streaked with bluish and yellowish.

Total length 180 millim.

Liberia.

2. PELMATOCHROMIS JENTINKI.

Paratilapia (Pelmatochromis) jentinkii, Steindachn. Notes Leyd. Mus. xvi. 1894, p. 43, pl. ii. fig. 1.

3 series of teeth in the upper jaw, 2 in the lower. Depth of body $2\frac{1}{3}$ to $2\frac{2}{5}$ times in total length, length of head 3 times. Snout longer than the diameter of the eye, which is contained $3\frac{1}{2}$ to $3\frac{2}{3}$ times in length of head, and nearly equals interorbital width; maxillary not extending to below anterior border of eye; 3 rows of scales on the cheek; moderate-sized scales on the opercle. Gill-rakers moderately long, hooked, 12 or 13 on lower part of anterior arch. Dorsal XIII-XIV 17; spines increasing in length to the last, which measures a little less than $\frac{1}{2}$ length of head, and about $\frac{3}{4}$ longest soft rays. Pectoral falciform, longer than the head. Outer ventral ray produced, filiform. Anal III 8-9; third spine as long as but stronger than longest dorsal spine, little shorter than longest soft rays. Caudal emarginate. Caudal peduncle as long as deep. Scales very finely denticulate on the edge, $40\frac{6}{15}$; lat. l. $\frac{28-29}{26-27}$, the lower beginning a short distance behind the shoulder. Golden; dorsal with straight horizontal violet streaks; anal with oblique violet streaks.

Total length 290 millim.

Liberia.

3. PELMATOCHROMIS LATERALIS.

Pelmatochromis guentheri, Bouleng. Ann. & Mag. N. H. (6) xvii. 1896, p. 310.

3 series of minute teeth in both jaws. Depth of body $2\frac{2}{5}$ times in total length, length of head 3. Snout $1\frac{1}{3}$ diameter of eye, which is $3\frac{1}{3}$ in length of head and equals interorbital width;

maxillary extending to below the nostril; 4 series of scales on the cheek; large scales on the opercle. Gill-rakers short, with wing-like basal process, 16 on lower part of anterior arch. Dorsal XVI 12; spines subequal from the fifth, $\frac{1}{2}$ length of head. Pectoral falciform, as long as head. Ventral reaching anal. Anal III 7; third spine longest, longer than dorsals. Caudal scaly, slightly emarginate. Caudal peduncle as long as deep. Scales cycloid, $32\frac{4}{8}$; lat. l. $\frac{23-24}{28-29}$, the upper ending below the last dorsal rays, the lower extending from the shoulder to the caudal, on which it is produced in three branches. Uniform pale brownish; dorsal membrane checkered with brown and white spots.

Total length 107 millim.

Upper Congo.

As Sauvage's *Hemichromis guentheri* turns out to belong to the genus *Pelmatochromis*, I am obliged to change the name first proposed for the present species.

4. PELMATOCHROMIS CONGICUS.

Pelmatochromis congicus, Bouleng. Ann. & Mag. N. H. (6) xx. 1897, p. 422.

3 series of teeth in both jaws. Depth of body $2\frac{1}{4}$ times in total length, length of head $2\frac{3}{4}$ times. Snout as long as diameter of eye, which is $2\frac{2}{3}$ in length of head and equals interorbital width; maxillary extending to below anterior third of eye; 4 series of scales on the cheek; opercle naked (?). Gill-rakers long and slender, about 20 on lower part of anterior arch. Dorsal XIII 11, spines subequal from the sixth, nearly $\frac{1}{2}$ length of head and $\frac{2}{5}$ longest soft rays, which are produced and filiform. Pectoral as long as head. Ventral with produced outer rays, reaching anal spines. Anal III 8; third spine as long as and stronger than longest dorsal spines. Caudal rounded. Caudal peduncle a little deeper than long. Scales cycloid, $30\frac{4}{11}$; lat. l. $\frac{21}{10}$. Olive, with yellowish spots occupying the centres of the scales; a rather indistinct dark lateral streak; vertical fins blackish, with round yellow spots.

Total length 175 millim.

Stanley Falls, Congo River.

5. PELMATOCHROMIS WELWITSCHI, sp. n. (Plate XIX. fig. 1.)

Teeth in 2 or 3 series in the upper jaw, in 3 in the lower. Depth of body equal to length of head, 3 times in total length. Snout with straight upper profile, twice as long as the diameter of the eye, which is 5 times in length of head and a little less than interorbital width; maxillary not extending to below anterior border of eye; 5 rows of scales on the cheek; large scales on the opercles. Gill-rakers short, denticulate, 9 on the lower part of anterior arch. Dorsal XIV 11; spines increasing in length to the seventh, which measures $\frac{1}{3}$ length of head and $\frac{1}{2}$ longest soft rays. Pectoral $\frac{2}{3}$ length of head. Ventral not reaching vent. Anal III 7;

third spine a little shorter than longest dorsal spines. Caudal truncate. Caudal peduncle a little longer than deep. Scales cycloid, $32 \frac{3\frac{1}{2}}{9}$; lat. l. $\frac{2\frac{1}{4}}{1}$. Pale brown; dorsal dark brown, whitish at the base; anal with a few round pure white spots; ventrals blackish.

Total length 125 millim.

Fluilla, Angola. A single specimen, collected by the late Dr. Welwitsch.

6. PELMATOCHROMIS GUENTHERI.

Hemichromis guentheri, Sauvage, Bull. Soc. Zool. France, 1882, p. 317, pl. v. fig. 1.

Hemichromis volta, Steind. Sitzb. Ak. Wien, xvi. i. 1887, p. 60, pl. i. fig. 3.

Teeth in 3 series in each jaw, outer largest but rather small. Depth of body $2\frac{2}{3}$ times in total length, length of head 3. Snout with straight upper profile, nearly twice as long as the eye, which is contained $4\frac{1}{2}$ times in length of head and nearly equals interorbital width; maxillary not extending to below anterior border of eye; 4 series of scales on the cheek; large scales on the opercle. Gill-rakers short, some T-shaped, 12 on lower part of anterior arch. Dorsal XVI 9; spines subequal, last $\frac{2}{5}$ length of head and $\frac{1}{2}$ longest soft rays. Pectoral $\frac{2}{3}$ length of head. Anal III 7; third spine a little shorter than longest dorsals. Caudal truncate. Caudal peduncle as long as deep. Scales smooth, $31 \frac{2\frac{1}{2}}{10}$; lat. l. $\frac{2\frac{0}{1}}{1}$. Pale olive; a few round blackish spots on the membrane between the dorsal spines.

Total length 140 millim.

Gold Coast.—The diagnosis is taken from the unique specimen in the Paris Museum.

7. PELMATOCHROMIS SUBOCELLATUS.

Hemichromis subocellatus, Günth. Proc. Zool. Soc. 1871, p. 667, pl. lxvii. fig. C.

Teeth in 2 or 3 series in each jaw, outer largest but small. Depth of body $2\frac{1}{2}$ to $2\frac{3}{4}$ in total length, length of head 3 times. Snout with convex upper profile, as long as the eye, which is contained $3\frac{1}{2}$ times in length of head and equals interorbital width; maxillary extending to below anterior border of eye; 2 or 3 series of scales on the cheek; large scales on the opercle. Gill-rakers short, some T-shaped, 10 on lower part of anterior arch. Dorsal XIV–XVI 8–9; spines subequal, about $\frac{1}{3}$ length of head and $\frac{1}{2}$ longest soft rays. Pectoral $\frac{2}{3}$ length of head. Ventral reaching vent or beyond origin of anal. Anal III 6–8; third spine as long as or a little longer than longest dorsals. Caudal rounded. Caudal peduncle a little deeper than long. Scales smooth, $26\text{--}28 \frac{2\text{--}2\frac{1}{2}}{11}$; lat. l. $\frac{16\text{--}18}{5\text{--}9}$. Brown, with more or less distinct blackish opercular spots and a rather indistinct dark lateral stripe; specimens with shorter ventrals (females?) have a blackish blotch or

ocellus on the soft dorsal; a black, white-edged ocellus sometimes present in the upper part of the caudal.

Total length 75 millim.

Gaboon.

5. CHROMIDOTILAPIA, g. n.

Body moderately elongate; scales cycloid. Teeth in a single or double series, the inner, if present, short or irregular; some of the larger ones with the crown bent at an angle to the shaft and directed backwards. Maxillary exposed. A cushion-like papillose pad on each side of the palate, close to the upper part of the branchial arches. Dorsal with 14 to 16 spines, anal with 3. Vertebrae 27 (14+13).

West Africa.

1. CHROMIDOTILAPIA KINGSLEYÆ, sp. n. (Plate XIX. fig. 2.)

Hemichromis schwebischi (non Sauvage), Günth. Ann. & Mag. N. H. (6) xvii. 1896, p. 273.

Teeth in a single or double series, the inner, if present, short and irregular. Depth of body $2\frac{1}{2}$ to $2\frac{4}{5}$ times in total length, length of head $2\frac{2}{3}$ to 3 times. Snout with straight upper profile, $1\frac{3}{4}$ to 2 times as long as the diameter of the eye (in the adult), which is 4 to $4\frac{1}{2}$ times in length of head and equal to or a little less than interorbital width; maxillary not reaching to below anterior border of eye; four series of scales on the cheek; large scales on the opercle. Gill-rakers on lower part of anterior arch short and broad, crenulated, 10 to 12. Dorsal XIV–XVI 10–12; spines increasing in length to the last, which is about $\frac{2}{5}$ length of head and hardly $\frac{1}{2}$ longest soft rays. Pectoral $\frac{2}{3}$ to $\frac{3}{4}$ length of head. Ventrals reaching vent or anal. Anal III 8–9; third spine as long as or a little shorter than longest dorsal spine. Caudal rounded. Caudal peduncle a little deeper than long. Scales with smooth border, 29–32 $\frac{2\frac{1}{2}-3}{9}$; lat. l. $\frac{19-21}{6-10}$. Brownish, uniform or with rather indistinct traces of six darker cross-bars; a more or less distinct dark opercular spot; fins greyish, blackish towards the border; soft dorsal and caudal, in some specimens, with regular squarish dark spots forming bars between the rays.

Total length 150 millim.

Gaboon, Ogowé.

2. CHROMIDOTILAPIA (?) FREDERICI.

Chromys frederici, Castelnau, Poiss. Afr. Austr. p. 15 (1861).

Teeth few, wide apart, in a single series except in front of the lower jaw. Body rather elevated. Dorsal XV 14. Anal III 8. Pectoral moderate. Scales finely granulate, with smooth edge. Lat. l. $\frac{22}{14}$. Greyish white; dorsal tipped with reddish; anal red; ventrals greenish; caudal reddish.

Total length 230 millim.

Lake Ngami.—Known only from Castelnau's very imperfect definition.

6. COREMATODUS.

Corematodus, Bouleng. Proc. Zool. Soc. 1896, p. 918.

Body short; scales cycloid. Jaws with extremely broad bands of innumerable minute club-shaped teeth with compressed oblique entire crowns. Dorsal with 16 spines, anal with 3. Vertebrae 32 (15+17).

A single species.

1. COREMATODUS SHIRANUS.

Corematodus shiranus, Bouleng. op. cit. p. 919, cum fig.

Depth of body equal to length of head, $\frac{1}{3}$ total length. Snout very broad, with steep, convex profile; eye a little nearer gill-opening than end of snout, its diameter $4\frac{1}{2}$ times in length of head, twice in interorbital width, and greater than depth of præorbital; maxillary extending to below anterior border of eye; cheek with 4 rows of scales below the eye; opercle and interorbital region scaleless; limbs of præopercle forming a right angle. Gill-rakers moderately long, 12 on lower part of anterior arch, last bifid. Dorsal XVI 10; spines increasing in length to the last, which is $\frac{2}{5}$ length of head. Anal III 8; third spine longest, as long as but thicker than middle dorsals. Caudal peduncle $1\frac{1}{2}$ as long as deep. Scales slightly rugose, not denticulate, $34\frac{2}{9}$; lat. l. $\frac{20}{7}$. Body with traces of six black cross-bars.

Total length 200 millim.

Upper Shiré River.

EXPLANATION OF PLATE XIX.

Fig. 1. *Pelmatochromis welwitschi* Blgr., p. 149. 1 a. Jaws, $\times 3$.

Fig. 2. *Chromidotilapia kingsleyæ* Blgr., p. 151. 2 a. Jaws, $\times 3$. 2 b. Gill-chamber, seen from below the opercle, $\times 2$.

3. The Myology of the Terrestrial Carnivora.—Part II.
By B. C. A. WINDLE, M.A., M.D., D.Sc., Professor of Anatomy at Mason University College, Birmingham, and F. G. PARSONS, F.R.C.S., F.Z.S., F.L.S., Lecturer on Comparative Anatomy at St. Thomas's Hospital, and Hunterian Professor at the Royal College of Surgeons.

[Received February 3, 1898.]

The first part of this paper was read before this Society on April 6th last year (see P. Z. S. 1897, p. 370); it contained an account of the muscles of the head, neck, and fore-limb. The present part contains a description of the muscles of the hind-limb and trunk. As we have been able to dissect some additional

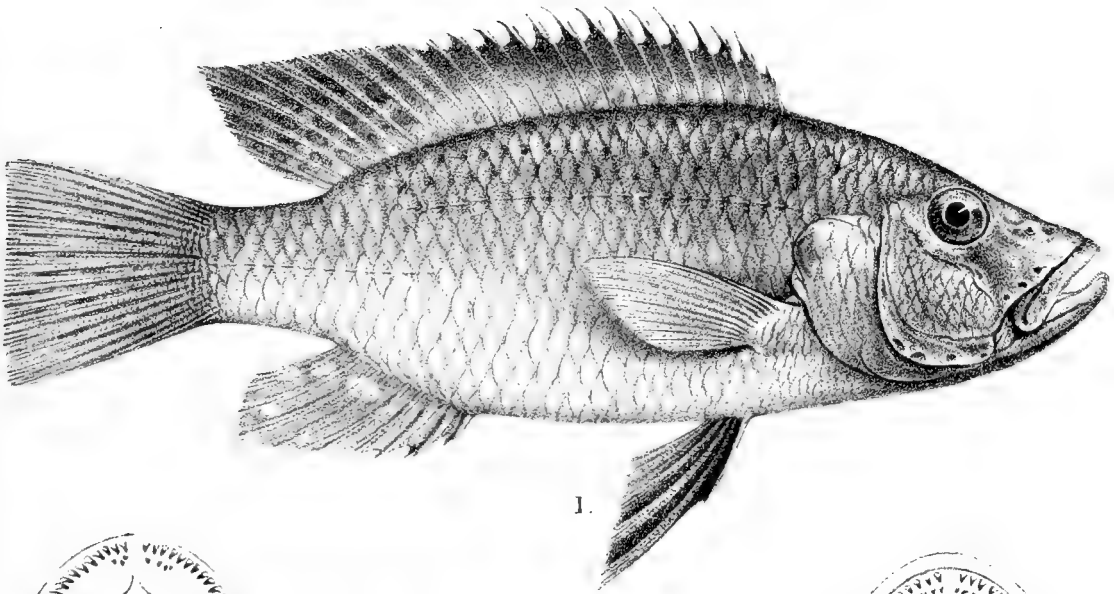

1.

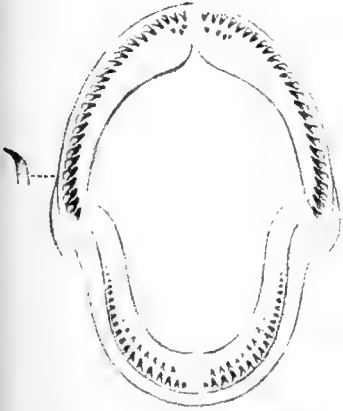

2a.

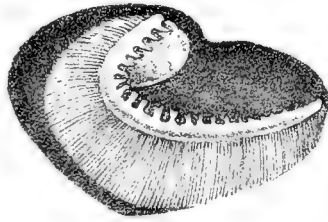

2b.

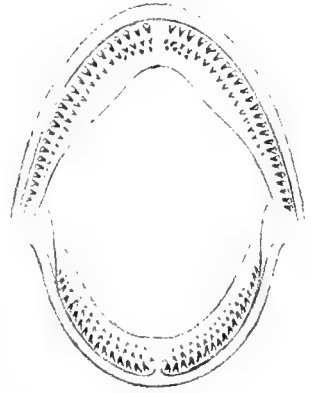

1a.

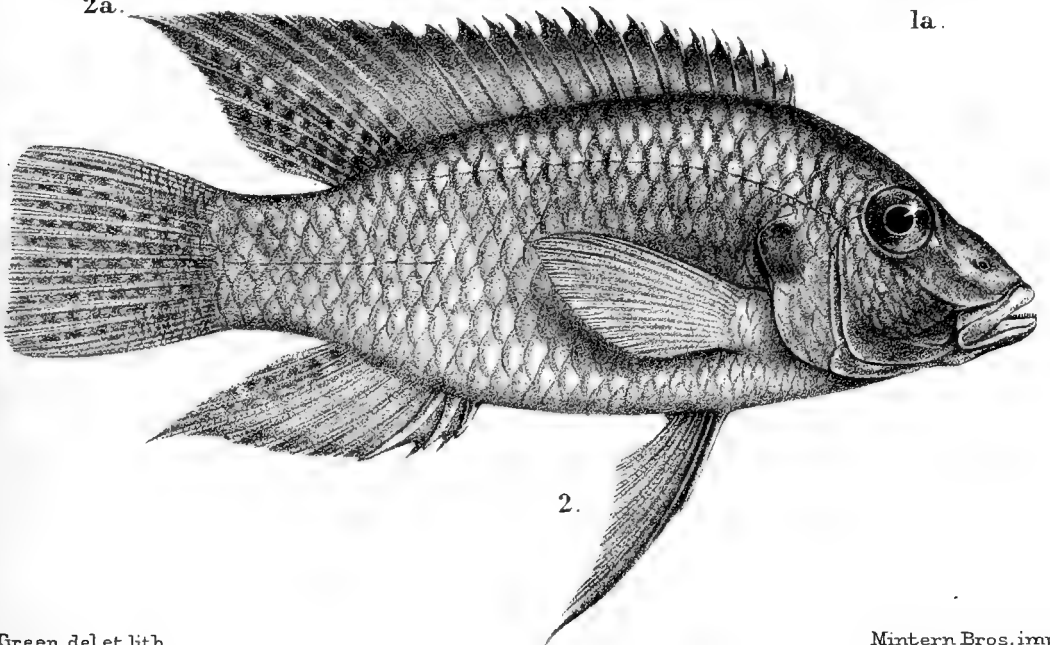

2.



animals since our last communication, a new list has become necessary, and we would again draw attention to the fact that the small numbers before each animal's name refer to mentions of it in the text, while the Roman numerals after the name refer to the bibliography at the end of the paper. When no Roman numeral is present the animal has been dissected by ourselves.

List of Animals.

FELIDÆ.

1. Lion (*Felis leo*). Macalister (unpublished).
2. Lion (*F. leo*). (V.)
3. Lion (*F. leo*). (III.)
4. Tiger (*F. tigris*). Macalister (unpublished).
5. Leopard (*F. pardus*). Macalister (unpublished).
6. Leopard (*F. pardus*).
7. Leopard (*F. pardus*). (VI.)
8. Ocelot (*F. pardalis*).
9. Cat (*F. catus*). (I.)
10. Cat (*F. catus*). (II.)
- 10 a. Cat (*F. catus*). (XXXIX.)
11. Caracal (*F. caracal*). (XXIX.)
12. Cheetah (*Cynelurus jubatus*). (IV.)

VIVERRIDÆ.

13. Fossa (*Cryptoprocta ferox*).
14. Fossa (*C. ferox*).
15. Fossa (*C. ferox*). (VII.)
16. Civet (*Viverra civetta*). (VIII.)
17. Civet (*V. civetta*). (IX.)
18. Civet (*V. civetta*). (X.)
19. Rasse (*Viverricula malaccensis*).
20. Blotched Genet (*Genetta tigrina*). (XI.)
21. Blotched Genet (*G. tigrina*).
22. Blotched Genet (*G. tigrina*). (XII.)
23. Common Genet (*G. vulgaris*).
24. Common Genet (*G. vulgaris*).
25. Palm Civet (*Paradoxurus typus*).
26. Palm Civet (*P. typus*).
27. Palm Civet (*P. typus*). (XXIX.)
28. Ichneumon (*Herpestes* sp. inc.). (XXXIX.)
29. Ichneumon (*H. nepalensis*).
30. Ichneumon (*H. griseus*).
31. Thick-tailed Mongoose (*Cynictis penicillata*).
32. Aard Wolf (*Proteles cristatus*). (XIII.)

HYÆNIDÆ.

33. Striped Hyæna (*Hyæna striata*). (XIV.)
34. Striped Hyæna (*H. striata*). (XXXIX.)

- 35. Striped Hyæna (*H. striata*). (XVI.)
- 36. Striped Hyæna (*H. striata*).
- 37. Spotted Hyæna (*H. crocuta*). (XV.)
- 38. Brown Hyæna (*H. brunnea*). (XVII.)

CANIDÆ.

- 39. Dog (var. Fox-terrier) (*Canis familiaris*).
- 40. Dog (var. Fox-terrier) (*C. familiaris*).
- 41. Dog (var. Irish Terrier) (*C. familiaris*) XVIII.)
- 42. Dog (var. Greyhound) (*C. familiaris*). (XVIII.)
- 43. Dog (var. Greyhound) (*C. familiaris*). Macalister (unpublished).
- 44. Dog (var. Pointer) (*C. familiaris*). Macalister (unpublished).
- 45. Dog (var. Setter) (*C. familiaris*). Macalister (unpublished).
- 46. Dog (var. Bull-dog) (*C. familiaris*). Macalister (unpublished).
- 47. Dog (? var.) (*C. familiaris*). (XXXIX.)
- 48. Dog (? var.) (*C. familiaris*). (XIX.)
- 49. Dingo Dog (*C. dingo*). (XVIII.)
- 50. Common Jackal (*C. aureus*). Macalister (unpublished).
- 50 a. Common Jackal (*C. aureus*).
- 51. Black-backed Jackal (*C. mesomelas*).
- 52. Common Fox (*C. vulpes*). (XXXVIII.)
- 53. Arctic Fox (*C. lagopus*). Macalister (unpublished).
- 54. Cape Hunting Dog (*Lycan pictus*). (XL.)

URSIDÆ.

- 55. Polar Bear (*Ursus maritimus*). (XXIV.)
- 56. Polar Bear (*U. maritimus*). (XXXIX.)
- 57. Brown Bear (*U. arctos*). (XXXIX.)
- 58. Black Bear (*U. americanus*).
- 59. Black Bear (*U. americanus*). (XX.)
- 60. Black Bear (*U. americanus*). (XXIII.)
- 61. Black Bear (*U. americanus*). (XXI.)
- 62. Black Bear (*U. americanus*). (XXII.)

PROCYONIDÆ.

- 63. Common Raccoon (*Procyon lotor*).
- 64. Common Raccoon (*P. lotor*). (XXVI.)
- 65. Common Raccoon (*P. lotor*). (XXVI.)
- 66. Common Raccoon (*P. lotor*). (XXXIX.)
- 67. Crab-eating Raccoon (*P. cancrivorus*). (XXV.)
- 68. White-nosed Coati (*Nasua narica*). (XXVII.)
- 69. Brown Coati (*Nasua fusca*). (XXVII.)
- 70. Red Coati (*N. rufa*). (XXVIII.)
- 71. Coati (? sp.) (*Nasua*) Meckel. (XXXIX.)
- 72. Kinkajou (*Cercoleptes caudivolvulus*).
- 73. Kinkajou (*C. caudivolvulus*).
- 74. Kinkajou (*C. caudivolvulus*). (XXIX.)

MUSTELIDÆ.

75. Grison (*Galictis vittata*).
76. Tayra (*G. barbara*). (IX.)
77. Polecat (*Mustela putorius*). (XXX.)
78. Beech Marten (*M. foina*). (XXXI.)
79. Beech Marten (*M. foina*). (XXVII.)
80. Beech Marten (*M. foina*). (XXVII.)
81. Beech Marten (*M. foina*). (XXXIX.)
82. Beech Marten (*M. foina*). (XXIX.)
83. Cape Polecat (*Ictonyx zorrilla*).
84. Libyan Polecat (*I. libyca*).
85. Badger (*Meles taxus*). Macalister (unpublished).
86. Badger (*M. taxus*). (XXXIII.)
87. Badger (*M. taxus*). (XXXIX.)
88. Common Otter (*Lutra vulgaris*).
89. Common Otter (*L. vulgaris*). (XXXVI.)
90. Common Otter (*L. vulgaris*). (XXXV.)
91. Common Otter (*L. vulgaris*). (XXXIX.)
92. Common Otter (*L. vulgaris*). (XXXIV.)
93. Indian Otter (*L. cinerea*) (XXXVII.)

Muscles of the Hind Limb.

Ectogluteus (*Gluteus maximus*).—This muscle is fairly constant in the Carnivora, it rises from the posterior two or three sacral spines and from the transverse processes of a like number of caudal vertebræ. Occasionally it derives a slight origin from the ilium. It is inserted into the femur, usually just below the great trochanter, as well as into the fascia lata. Anteriorly its edge is continuous with that of the tensor fasciæ femoris, posteriorly with that of the biceps; indeed, the sartorius, tensor fasciæ femoris, ectogluteus, and biceps form a muscular sheath round the outer two-thirds of the thigh, and it is often quite difficult to determine where one muscle ends and the other begins. Among the Felidæ the foregoing description applies to *Felis leo* (1, 2, 3), *F. tigris* (4), *F. pardus* (5, 6, 7), *F. pardalis* (8), *F. catus* (9), and *Cynælurus* (12). Among the Viverridæ it applies to *Cryptoprocta* (13, 14), *Viverra* (17), *Viverricula* (19), *Genetta tigrina* (20), *G. vulgaris* (23, 24), *Paradoxurus* (25, 26), *Herpestes nepalensis* (29), *H. griseus* (30), and *Cynictis* (31).

Young (VIII.) describes the muscle in *Viverra* (16) as being inserted into the whole length of the shaft of the femur, though this description probably includes the agitator caudæ. Cuvier and Laurillard (XII.) found the muscle divided into three parts in *Genetta tigrina* (22); of these one is evidently the agitator caudæ, while the rest consists of a superficial and a deep layer. This arrangement is clearly exceptional, as it was not noticed in any other specimen of Genet. *Proteles* (32) seems to differ from the typical arrangement in not having the ectogluteus continuous with the biceps.

Among the Hyænidæ, Meckel notices a separation between the sacral and caudal parts of the muscle in *Hyæna striata* (34), and the same arrangement is recorded by Young (33) and, in *Hyæna crocuta*, by Watson (37).

Fig. 1.

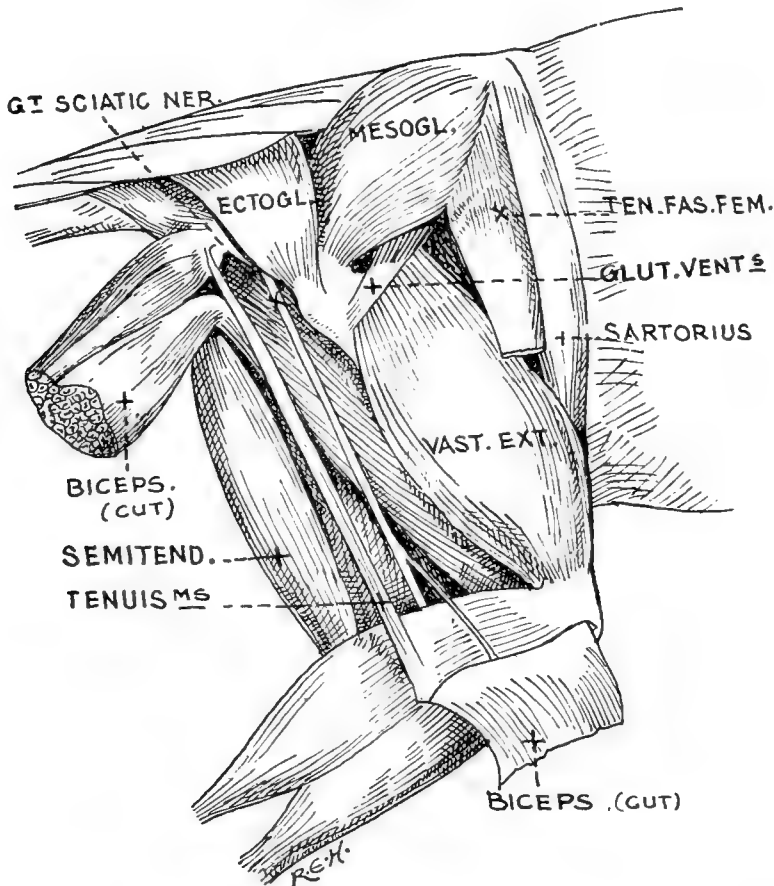
External muscles of thigh of *Canis familiaris*.

Among the Canidæ the typical arrangement exists in *Canis familiaris* (39, 48), *Canis aureus* (50 a), and *Canis mesomelas* (51), except that the ectoglutæus and tensor fasciæ femoris are separated by a considerable interval (see fig. 1). In the Ursidæ, Kelley (XXIV.) states that there is no fascial insertion in *Ursus maritimus* (55), while Shepherd (XX.), in *Ursus americanus* (59), found almost the whole muscle inserted into fascia, so that further observations on this point are necessary. The Procyonidæ are remarkable for having the ectoglutæus inserted almost entirely into bone just below the great trochanter; this applies to *Procyon* (63, 64, 65), *Nasua* (68, 70), and *Cercoleptes* (72). The same arrangement exists among the Mustelidæ in *Mustela foina* (78), *Ictonyx* (84), *Meles taxus* (86), and *Lutra* (88, 93).

The *Caudo-femoralis* (*Agitator caudæ*) is an intermediate muscle between the ectogluteus and the biceps, though it is usually more closely associated with the former than the latter; in some cases it is a perfectly distinct muscle, while in others no trace of it is recorded. By many authors its presence seems to have been entirely ignored, though others have evidently noticed it and described it as a part of the ectogluteus. It seems to have very little action on the tail and, for this reason alone, its name is not a particularly happy one; it is further liable to objection for the following reason—if the muscle does act on the tail its crural attachment must be considered the origin and its caudal the insertion: this is just the opposite to the manner in which the attachments of the ectogluteus and biceps are, we think rightly, described. For these reasons we prefer the name of caudo-femoralis for this muscle. The origin is from the anterior two or three caudal vertebræ, either continuous with, or deep to, the ectogluteus, while the insertion may be anywhere into the shaft of the femur, from the middle to just above the external condyle or, in some cases, as low as the patella.

Among the Felidæ the muscle is present in *Felis leo* (1, 2, 3), and is in each case inserted into the patella. The same description applies to *Felis tigris* (4) and *Felis pardus* (5, 6, 7). In *Felis pardalis* (8) we found the caudo-femoralis very well marked, part of it being inserted into the back of the femur and part into the patella, these two parts were united at their origin and supplied by the same nerve. In *Felis catus* the muscle is figured by Mivart (I.) and Straus-Durckheim (II.), though not specially described; its insertion does not seem to reach the patella in this animal.

Among the Viverridæ the muscle is very constant and is usually inserted into the lower third of the shaft of the femur. It is present in *Cryptoprocta* (13, 14, 15), *Viverra civetta* (16, 17), *Viverricula malaccensis* (19), *Genetta* (20, 22, 23), *Herpestes* (29), and *Cynictis* (31). In two specimens of *Paradoxurus* (25, 26) and one of *Genetta* (24), the muscle was double. *Herpestes griseus* (30) was the only member of the Viverridæ in which the muscle was carefully looked for and not found. Among the Hyænidæ we can find no record of the presence of this muscle. *Proteles* (32) is described as agreeing with *Hycena crocuta* (37) in its gluteal muscles, and in the latter animal no caudo-femoralis seems to have existed. Among the Canidæ we have records of six Dogs (39, 43, 44, 45, 46, 48) in which the muscle was looked for but in none of which was it found (see fig. 1). It is not present either, as a distinct muscle, in *Canis aureus* (50, 50 a), *Canis mesomelas* (51), or *Canis lagopus* (53), while Pagenstecher (XL.) makes no mention of it in *Lycaon* (54).

We have been unable to find the caudo-femoralis or any mention of it in the Ursidæ.

Among the Procyonidæ the muscle is absent in *Procyon lotor* (63, 64, 65), but is present and inserted into the lower part of the femur in *Nasua* (68, 69, 70) and *Cercoleptes* (72). It is present

among the Mustelidæ in *Mustela foina* (78), one specimen of *Meles* (85), and *Lutra cinerea* (93), but absent in *Ictonyx* (84), one specimen of *Meles* (86), and *Lutra vulgaris* (88). We are therefore inclined to regard this muscle as being constant and usually attached to the patella in the Felidæ, constant and attached to the femur in the Viverridæ, present or absent in the Procyonidæ and Mustelidæ, absent in the Canidæ, Hyænidæ, and Ursidæ.

Tensor fasciæ femoris.—This, as we have already pointed out, is the ventral continuation of the ectogluteus. It rises from the crest of the ilium and is inserted into the fascia lata about the middle of the outer side of the thigh, mesially it is continuous with the sartorius. Its degree of development varies greatly in different animals and apparently in different specimens of the same animal; for this reason we have decided not to describe it in detail throughout the order. In one specimen of *Felis pardus* (5) it reached the patella, while in *Ictonyx lybica* (84) it could not be made out at all. Macalister found it divided into an external and internal part in a Dog (43).

Mesogluteus (Gluteus medius).—This muscle, as in most mammals, is by far the largest of the glutei; it rises from the dorsal part of the gluteal surface of the ilium as well as from the fascia lata covering it. Its insertion is into the outer side of the great trochanter, and it lies in such close relationship to the pyriformis that that muscle can only be separated from it with great difficulty. In some cases, e. g. *Hyæna crocuta* (37), *Canis aureus* (50), and *Procyon lotor* (64), the muscle is distinctly bilaminar.

Entogluteus (Gluteus minimus) rises from the ventral part of the gluteal surface of the ilium and is inserted into the front of the great trochanter. It is part of the same layer as the obturator internus and gemelli, and is quite constant in all the Carnivora.

Gluteus ventralis (Scansorius, Gluteus quartus).—This is a differentiation of the ventral fibres of the entogluteus, and rises from the ventral border of the ilium, close to the origin of the rectus femoris, and is inserted into the lower part of the front of the great trochanter in the region of the anterior introchanteric or spiral line of the femur. Some writers, following the example of Macalister, call this muscle the gluteus quintus, and use the term gluteus quartus for another differentiation of the entogluteus; for this reason it seems best to avoid the terms quartus and quintus and to speak of this muscle as the gluteus ventralis. Among the Felidæ the muscle was found in *Felis leo* (1) by Macalister, but is not mentioned by Houghton (3), or figured by Cuvier and Laurillard (2). It is also present in *Felis pardus* (5, 6), *Felis catus* (10, 11), and *Cynælurus jubatus* (12). Among the Viverridæ it was present in *Cryptoprocta* (13), *Viverra* (17), *Viverricula* (19), *Genetta* (20, 22, 23, 24), *Paradoxurus* (25), *Cynictis* (31), and *Proteles* (32). In *Paradoxurus* (26) and *Herpestes* (30) it was not found. In *Hyæna striata* among the Hyænidæ the muscle was found by Meckel (34), but not by Young and Robinson (33). In *Hyæna crocuta* (37) it was present. Among the Canidæ it was found in two specimens

of *Canis familiaris* (45) out of six (see fig. 1). It was absent in *Canis aureus* (50, 50 a), *Canis mesomelas* (51), *Canis lagopus* (53), and *Lycan pictus* (54).

In the Ursidæ Shepherd and Cuvier and Laurillard noticed it in *Ursus americanus* (59, 62). Among the Procyonidæ it was absent in *Procyon lotor* (63, 64, 65) and *Nasua narica* (68), but was found in *Nasua fusca* (69) and *Cercoleptes* (72); while among the Mustelidæ it was found in *Galictis vittata* (75), *Galictis barbara* (76), *Meles* (85, 86), and *Lutra* (88, 93), but was not seen in *Ictonyx libyca* (84). From the foregoing we are of opinion that the gluteus ventralis may be distinguished from the entoglutæus, if carefully looked for, in most of the Carnivora.

Gluteus profundus (*Gluteus quintus, ilio-capsularis*).—This small muscle is described very accurately by Douglas¹ in the Dog. It rises from the ilium just above the acetabulum, and passes over the capsule of the hip-joint to be inserted into the upper part of the anterior surface of the shaft of the femur, between the origins of the vastus internus and crureus. We have records of the presence of the muscle in the following animals:—*Felis pardus* (6), *Felis pardalis* (8), *Cynælurus* (12), *Genetta vulgaris* (24), *Cynictis penicillata* (31), *Hyaena striata* (36), *Canis familiaris* (44, 45), *Canis aureus* (50), and *Meles taxus* (85). Owing to its small size it is easily overlooked, and our notes do not enable us to say whether it is constantly absent in any special genus or family.

Pyriformis.—This muscle, as has already been mentioned, is frequently so blended with the mesoglutæus as to be with difficulty made out. If the origin from the sacrum, however, be carefully looked for, the muscle can usually be separated. It seems to be a very constant muscle in the Carnivora, rising from the ventral surface of the sacrum and being inserted into the top of the great trochanter. Apart from its greater or less degree of distinctness, we have met with no special variations.

Obturator internus.—This has the human origin and insertion. Where the tendon passes round the lesser sacro-sciatic notch its deep surface is marked by five or six ridges separated by furrows.

Gemelli.—In the Carnivora the two gemelli are seldom, if ever, separate; they form a continuous origin from the ventral edge of the lesser sacro-sciatic notch, and lie deep to the obturator internus, overlapping it in front and behind. The anterior part, which corresponds to the superior gemellus of human anatomy, is usually the larger, though in one specimen of *Lutra* (88) only the posterior gemellus was present; this, however, appears to have been an individual variation.

Obturator externus.—This rises from the outer surface of the obturator membrane, but much more strongly from the bone on the dorsal and posterior margins of the foramen. It is inserted as usual into the digital fossa of the great trochanter. We have met with no variations of it.

¹ 'Descriptio Musculorum,' 1738, p. 146.

Quadratus femoris.—A large and fleshy muscle rising from the tuberosity and ramus of the ischium, and being inserted into the inter-trochanteric line of the femur as well as the surface of bone below on a level with the lesser trochanter. As a rule it is quadrilateral, but sometimes the insertion is narrower than the origin; this, however, seems to depend very little on the relationships of its possessor. Watson (XIII.) describes the muscle as wanting in *Proteles*.

Ilio-tibialis (Sartorius).—This rises from the ventral portion of the crest of the ilium and is inserted into the inner side of the patella, ligamentum patellæ, and cnemial crest of the tibia. In many of the Carnivora it is double, and when this is the case the anterior part is usually inserted into the patella, the posterior into the tibia.

Among the Felidæ the muscle is apparently always single; this is the case in *Felis leo* (1, 2), *F. tigris* (4), *F. pardus* (5, 6, 7), *F. pardalis* (8), and *F. catus* (9).

Among the Viverridæ the muscle may be single or double. In the following it is single:—*Cryptoprocta* (13, 14), *Viverra* (16), *Genetta* (24), and *Herpestes* (30). In the following it is double:—*Viverra* (17), *Viverricula* (19), *Genetta* (20, 22, 23), *Paradoxurus* (25, 26), and *Herpestes* (29). In *Cynictis* (31) the two parts are united by fascia, while in *Proteles* (32) the muscle divides near its insertion. In the specimen of Genet (23) which we dissected the muscle was bilaminar, the superficial part going to the tibia, the deep part to the fascia over the rectus and vastus internus in the middle of the thigh.

Among the Hyænidæ the ilio-tibialis is always double:—*Hyæna striata* (33, 35, 36) and *H. crocuta* (37). In *Hyæna striata* (33, 36) the shorter part joins the rectus and acts as a fifth head of the quadriceps extensor.

Among the Canidæ the muscle is also double; this was the case in the following eight specimens of *Canis familiaris* (39, 41, 42, 43, 44, 45, 46, 48), in *C. aureus* (50, 50 a), in *C. mesomelas* (51), and *C. lagopus* (53).

In the Ursidæ it seems to be usually single; this is the case in *Ursus arctos* (57) and *U. americanus* (59, 60, 62).

Among the Procyonidæ it is single in *Procyon lotor* (63, 64, 65, 66), *P. cancrivorus* (67), and *Cercoleptes* (72). In *Nasua narica* and *fusca* (68, 69) it divides at its insertion according to Mackintosh, but in Cuvier and Laurillard's plate of *Nasua rufa* (70) the muscle is single.

In the Mustelidæ it is single in *Galictis vittata* (75) and *barbara* (76), *Mustela foina* (78, 82), *Ictonyx libyca* (84), *Meles taxus* (85, 86), and *Lutra* (88, 89, 90). Macalister also says that it is single in *Lutra cinerea* (93). It will thus be seen that the ilio-tibialis is always single in the Felidæ and very generally so in the Ursidæ, Procyonidæ, and Mustelidæ. In the Hyænidæ and Canidæ it is always double, while in the Viverridæ it may be single or double.

Adductor cruris (Gracilis).—This muscle is always single in the

Carnivora; it is broad and thin, and rises from the symphysis and posterior ramus of the pubes to be inserted into the cnemial crest of the tibia just below the insertion of the ilio-tibialis (sartorius), in most cases into the second quarter of the tibia (see fig. 2). In *Proteles* (32), Watson describes it as rising from the fascia over the adductores femoris, and being inserted into the tibia at the junction of the middle and lower thirds.

Fig. 2.

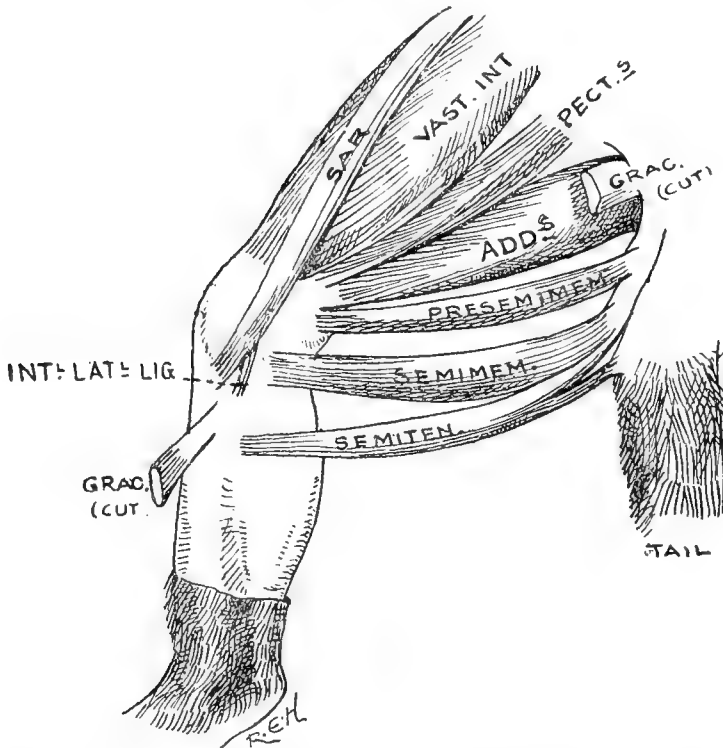
Inside view of thigh-muscles of *Herpestes*.

(The semimembranosus and pre-semimembranosus have been artificially separated.)

Pectineus.—This muscle, in many cases, is extremely difficult to separate satisfactorily from the superficial part of the adductor mass, and there can be little doubt that what one observer would describe as a large or double pectineus, another would call pectineus and adductor longus. We therefore feel quite incapable of dogmatizing on the subject and merely give the following notes for what they are worth. In *Felis leo* (2) Cuvier and Laurillard figure the muscle as double. In *Felis catus* (9) Mivart describes it as small, yet reaching halfway down the thigh. In *Cryptoprocta* (14) we found the muscle reaching halfway down the thigh and feebly separated into an outer and inner part; in another specimen of the same animal (13), which we examined, no separation could be

made out. In *Viverra civetta* (16) Young describes the muscle as large and bilaminar, but says that the superficial part may represent an adductor longus. Macalister says of the same animal (17), that the muscle is small and normal. In two specimens of Genet (20, 23), one of which we dissected ourselves, the pectineus was single and extended halfway down the thigh; in another (24) we found it divided into an inner and outer part. In *Herpestes* it reaches nearly to the lower end of the femur (see fig. 2).

In *Proteles* (32) and the Hyænidæ (33, 36, 37) the muscle is single and unilaminar.

In the Canidæ the same arrangement exists.

In the Ursidæ Cuvier and Laurillard describe the muscle in *Ursus americanus* (62) as dividing into three parts, but this arrangement has not been noticed by other observers.

Among the Procyonidæ we found the pectineus distinctly bilaminar in *Procyon lotor* (63). Allen (XXVI.) says of his two specimens of this animal (64, 65), that the pectineus and adductor brevis rise from the ilio-pectineal line and are both supplied by the anterior crural nerve; this origin and nerve-supply make us regard that which he speaks of as adductor brevis as one layer of the pectineus. In *Nasua* the condition of the muscle does not seem to have been noticed, but in *Cercoleptes* (72) we found it distinctly bilaminar. Among the Mustelidæ we have no records of a bilaminar muscle.

Adductor Mass (Adductores femoris).—This mass of muscles rises from the ventral surface of the body and posterior ramus of the pubes as well as from the ramus and tuberosity of the ischium; it is inserted into the whole length of the back of the shaft of the femur. We do not feel justified in attempting to divide this mass into the adductor longus, brevis, and magnus of human anatomy; sometimes it can easily be divided in four or five layers, at others it is impossible to divide it at all.

The *Semimembranosus* rises from the tuberosity of the ischium and is often closely fused with the adductor mass in the thigh. It is inserted into the internal tuberosity of the tibia, deep to the internal lateral ligament of the knee, by tendon. Some of the fibres are also inserted into just above the internal condyle of the femur and are separated from the adductor insertion by the femoral artery. This pre-semimembranosus or ischio-supracondyloideus is of special interest when compared with the same muscle in other animals. In the Rodents, for instance, it is often quite a separate muscle rising from the caudal vertebra; in animals as far apart as man and the kangaroos it is intimately connected with the adductors, while in the macaque monkey it rises from the tuberosity of the ischium and is a distinct muscle down to its insertion. However it may vary in other respects, its insertion and nerve-supply from the sciatic are always constant. In the Carnivora the ischio-supracondyloideus is always part of the semimembranosus in the thigh, and always rises with that muscle from that tuberosity of the ischium, so that most writers describe the

semimembranosus in this order as having a femoral and a tibial insertion (see fig. 2).

Semitendinosus.—This always rises from the tuberosity of the ischium, but often has an extra head from the transverse processes of two or three of the anterior caudal vertebræ (see fig. 2). Where these two heads unite, in the upper third of the thigh, there is often a transverse tendinous intersection, e. g. *Genetta* (23), *Viverra* (17), *Herpestes* (30), *Nasua* (68), and *Lutra* (93). The insertion is into the inner side of the cnemial crest of the tibia just below that of the gracilis and into the fascia of the leg; the lower fibres are continued with those of the biceps down to the calcaneum, helping to encapsule the tendo Achillis.

In the Felidæ the caudal head is not present—*Felis leo* (2, 3), *F. pardus* (6, 7), *F. pardalis* (8), and *F. catus* (9). In the Viverridæ, if we except *Proteles*, the caudal head is always present in addition to the ischial one—*Cryptoprocta* (13, 14, 15), *Viverra* (16, 17), *Viverricula* (19), *Genetta* (20, 22, 23, 24), *Paradoxurus* (25, 26), *Herpestes* (29, 30), and *Cynictis* (31).

Among the Hyænidæ, with which *Proteles* as usual agrees, the caudal head is wanting—*Hyæna striata* (33, 35, 36), *H. crocuta* (37), and *Froteles* (32).

Among the Canidæ there is no caudal origin in *Canis familiaris* (39, 48), *C. aureus* (50a), or *C. mesomelas* (51).

In the Ursidæ the same description applies—*Ursus americanus* (58, 59, 62). In the Procyonidæ the two heads are always present—*Procyon lotor* (63, 64, 65), *P. cancrivorus* (67), *Nasua narica* (68), *N. fusca* (69), *N. rufa* (70), and *Cercoleptes* (72, 73, 74).

Among the Mustelidæ the caudal head is sometimes present, sometimes absent. It is present in *Galictis vittata* (75), *Mustela foina* (78), *Ictonyx libyca* (84), and *Lutra* (88, 90, 93). Absent in *Ictonyx zorilla* (83) and *Meles taxus* (86).

From the above it will be seen that the presence or absence of the caudal origin of the semitendinosus is very characteristic of different families of the Carnivora; it seems always to be present in the Viverridæ and Procyonidæ, always absent in the Felidæ, Hyænidæ, Canidæ, and Ursidæ, while in the Mustelidæ it is inconstant.

Flexor cruris lateralis (*Biceps femoralis*).—This muscle, as has already been pointed out, forms part of the same sheet as the ectogluteus and tensor fasciæ femoris, it is therefore difficult to decide whether certain bundles of fibres should be included in the description of the biceps or of the ectogluteus; this is especially the case with those fibres which are inserted into the lower end of the femur. The biceps in all cases rises from the tuber ischii, but it may be reinforced by an extra head from the caudal vertebræ; this head is quite distinct from the tenuissimus, which will be dealt with later, and from the caudo-femoralis, which has been already considered. The insertion is into the fascia of almost the whole of the outer side of the leg, the highest fibres going to the patella, while the lowest are continued down with the tendo Achillis, and

are often reinforced by some of the lower fibres of the semitendinosus. We do not propose to lay any stress on the presence or absence of the caudal head, since it is so difficult to determine whether it should be included with the ectoglutæus or not, and we are uncertain what views other observers have taken of it.

Tenuissimus (Bicipiti accessorius).—This, as its name implies, is a slender ribbon-like muscle which usually rises from the first caudal vertebra and passes down the back of the thigh and leg, deep to the biceps and superficial to the great sciatic nerve. In the lower part of the leg it usually joins the lowest fibres of the biceps and, with them, is conducted down to the calcaneum, helping to ensheath the tendo Achillis. We should like here to call special attention to this prolongation of the flexor lateralis to the calcaneum with the tendo Achillis. The muscle passes over three joints, being an extensor of the hip, a flexor of the knee, and a plantar flexor of the ankle. It probably assists in the leaping-powers of the animal possessing it. How far this continuation downward is present in orders other than Carnivora we do not at present know.

The tenuissimus seems to be very constantly present among the Carnivora, though, as it adheres somewhat closely to the deep surface of the biceps, it is apt to be missed unless specially looked for. In the following animals its presence was noticed and in no case, with the exception of that of *Cynælurus* (12), is it definitely stated that the muscle was absent:—*Felis leo* (1, 2, 3), *F. tigris* (4), *F. pardus* (5, 6, 7), *F. pardalis* (8), *F. catus* (9), *Cryptoprocta* (13, 14, 15), *Viverra* (16, 17), *Viverricula* (19), *Genetta* (20, 23, 24), *Paradoxurus* (25, 26), *Herpestes* (29, 30), *Cynictis* (31), *Hyæna striata* (36), apparently in *Hyæna crocuta* (37), *Canis familiaris* (39, 41, 42, 43, 44, 45) (see fig. 1), *C. aureus* (50, 50 a), *C. mesomelas* (51), *Ursus americanus* (58, 59), *Procyon lotor* (63, 64, 65), in one specimen (65) Allen (XXVI.) records that the muscle rose from the third trochanter; *Nasua* (68, 69), *Cercoleptes* (72), *Galictis* (75), *Mustela* (82), *Meles* (85, 86), and *Lutra* (88, 90, 93).

Quadriceps extensor.—The four muscles which make up the quadriceps show little variety in the Carnivora. The rectus (superficialis quadricipitis) is sometimes described as rising by one head, sometimes by two, and it is interesting to note that in some cases the straight head is said to be present, in others the reflected. In the animals which we have ourselves dissected we have paid a good deal of attention to this point, and we feel convinced that there is no real suppression of either head, but that they rise very close together, and that the interval between them is filled up by fibrous tissue, thus giving the appearance of one broad origin. The remaining three parts of the quadriceps—mesialis, lateralis, and profundus—are more or less fused, but the lateralis (vastus externus) always exceeds the mesialis (v. internus) in size. The profundus quadricipitis (crureus) may rise from the whole of the shaft of the femur, but more commonly it misses the upper fourth.

Tibialis anticus.—This muscle rises from the upper two-thirds

or so of the shaft of the tibia, and, when it is well developed, encroaches on the fibula. It never has any origin from the femur as is sometimes the case in rodents. When five toes are present the tendon is inserted chiefly into the base of the first metatarsal, though some of the fibres may go to the entocuneiform. In the Felidæ and Canidæ, where the hallux is rudimentary, the tibialis anticus is inserted into that rudiment; but in the Hyænidæ, where the hallux is quite suppressed, it goes to the base of the second metatarsal bone. In many specimens the tendon or the whole of the tibialis anticus is double; this, however, appears to be an individual variation and is not indicative of any family or genus. For instance, Shepherd describes two tendons in *Ursus americanus* (XX.), but this was not noticed in any other specimen of the same animal. Watson says that in *Hyæna crocuta* the muscle is double halfway down (XV.); this is not the case in any specimen of *Hyæna striata* recorded. In *Mustela foina* Perrin found two tibiales antici (XXIX.), but in Cuvier and Laurillard's specimen (XXXI.) the muscle was entirely undivided.

Extensor proprius hallucis.—This muscle, when it is present, rises from some portion of the upper half of the fibula, and is inserted into the dorsum of the base of the terminal phalanx of the hallux. The tendon closely accompanies that of the tibialis anticus, and is often described as coming off from that: careful dissection will, however, always show that the two tendons are really connected with separate fleshy bellies, although they lie in the same synovial sheaths in passing the annular ligament. Among the Felidæ, in spite of the rudimentary condition of the hallux, the extensor hallucis often persists. It was found in *Felis leo* (1), *F. tigris* (4), *F. pardus* (6), and *F. pardalis* (8); on the other hand, it was absent in *F. leo* (2), *F. pardus* (7), and *F. catus* (9). One of us has already noticed (XLI.) that in Rodents this muscle is more persistent than the toe which it should move. When the toe has disappeared and the muscle remains, the latter acquires an insertion into the slip of the extensor longus digitorum to the second toe. Among the Viverridæ, the muscle is present in the following animals:—*Cryptoprocta* (13, 14); *Viverra* (16, 17); *Viverricula* (19); *Genetta* (20, 22, 23, 24), in one specimen (20) it ended in an expansion to the first and second digits; *Paradoxurus* (25, 26). In *Herpestes* the muscle was present in one specimen (29), absent in another (30) (see fig. 3). In *Cynictis* (31) it joined the slip of the extensor brevis digitorum to the inner toe. In *Proteles* and the Hyænidæ it appears to be always wanting (32, 33, 34, 35, 36, 37). Among the Canidæ, it is usually absent in *Canis familiaris* (43, 44, 45, 46, 48) and *C. lagopus* (53), but it was found in two specimens of *C. aureus* (50, 50 a), and in one of *C. mesomelas* (51).

In the Ursidæ it has been seen in *Ursus arctos* (57) and *U. americanus* (58, 62).

In the Procyonidæ it is present in the following animals:—*Procyon lotor* (63, 64, 66), *P. cancrivorus* (67), *Nasua* (68, 70), and *Cercoleptes* (72). In one specimen of *Procyon lotor* (65) Allen

(XXVI.) failed to find it. Among the Mustelidæ it was found in every case in which it was looked for:—*Galictis* (75), *Mustela foina* (78, 79), *Ictonyx libyca* (84), *Meles* (85, 86), and *Lutra* (88, 93).

Fig. 3.

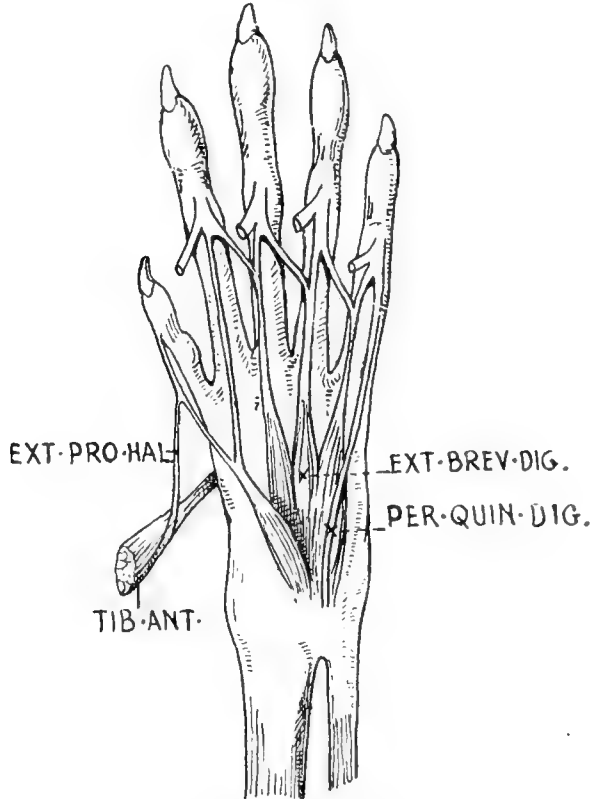
Muscles of hind foot of *Herpestes* (dorsal view).

Extensor longus digitorum.—This muscle has the typical mammalian arrangement: it rises from the front of the outer condyle of the femur by a tendon which passes through the knee-joint; on reaching the leg it expands into a muscular belly, which in the lower third again becomes tendinous and passes through a strong fibrous loop, which binds it to the calcaneum. After this a slip is given off for the middle and distal phalanges of each of the four outer toes. The above description is very constant for the Carnivora. Occasionally the fleshy belly may be more or less divided into two, as in *Ursus americanus* (59) and Meckel's specimen of *Hyæna striata* (34), though this was not noticed in other Hyænas (33, 35, 36). Occasionally one or more of the four tendons may be wanting; in *Procyon cancrivorus* (67) and *Hyæna crocuta* (37) it is the tendon to the fifth toe which is absent, but in one of Allen's Racoons (65) the only tendons present were those to the second and fifth toes.

Extensor brevis digitorum.—This muscle rises from the anterior part of the dorsal surface of the calcaneum and divides into tendons which join those of the extensor longus. As a rule tendons pass to the four inner toes, but occasionally a slender slip runs to the fifth also. In the Felidæ, where the hallux is aborted, there are only three tendons for the 2nd, 3rd, and 4th toes; this is the case in *Felis leo* (1, 2), *F. tigris* (4), and *F. catus* (9). Among the Viverridæ, tendons are given off to the four inner toes in *Cryptoprocta* (13), *Viverra* (16), and *Genetta* (22, 23, 24). The specimen of *Herpestes griseus* (30) which we dissected was remarkable for having slips of the extensor brevis to all five toes (see fig. 3). *Proteles* (32), on the other hand, has only tendons to the second and third toes. Among the Hyænidæ there are always tendons to the 2nd, 3rd, and 4th toes (33, 34, 35, 36, 37), and, in addition, a feeble slip went to the fifth in two specimens of *Hyæna striata* (33, 36). The Canidæ resemble the Hyænidæ in the absence of the hallux; consequently we find tendons running to the 2nd, 3rd, and 4th toes in *Canis familiaris* (48), *C. aureus* (50 a), and *C. mesomelas* (51). In one Dog (39) a small slip went to the fifth toe in addition.

The Ursidæ and Procyonidæ have tendons to the 1st, 2nd, 3rd, and 4th toes: this is the case in *Ursus arctos* (57), *U. americanus* (59, 62), *Procyon lotor* (63), *P. cancrivorus* (67), *Nasua* (70, 71), and *Cercoleptes* (72, 73, 74). In *Ursus maritimus* (55) and one specimen of *Procyon lotor* (64) the tendon to the hallux was absent. The Mustelidæ resemble the Ursidæ and Procyonidæ in usually having tendons for the 1st, 2nd, 3rd, and 4th toes: these were present in *Galictis vittata* (75), *Mustela putorius* (77), *M. foina* (78), *Meles* (86), and *Lutra* (93). In *Ictonyx libyca* (84) and *Lutra* (88) the slip to the hallux was absent.

Peroneus longus.—This muscle rises from the head and upper part of the shaft of the fibula, occasionally encroaching on the adjacent portion of the tibia. Some of the fibres of the external lateral ligament of the knee are continuous with its origin. The tendon of insertion runs in a separate groove on the outer side of the external malleolus, turns round the cuboid, and passes across the sole of the foot to be inserted into the base of the first or, when that is absent, the second metatarsal bone. With regard to the origin, Ruge (XLVIII.) states that in *Hyæna*, *Nasua*, and *Meles* it comes from the external condyle of the femur. We have failed to find any confirmation of this by other authors, and in our own specimen of *Hyæna* (36) the muscle certainly rose from the fibula. As the tendon passes round the cuboid, a slip is sometimes given to the base of the 5th metatarsal bone: this was noticed by Young and Macalister in *Viverra* (16, 17), and by Mivart in *Genetta* (20). In our own specimen of *Genetta* (23) we paid special attention to this point, and satisfied ourselves that the apparent attachment to the base of the fifth metatarsal belonged to the sheath of the tendon, and not to the tendon itself. In *Proteles* (32) and *Hyæna crocuta* (37), Watson found the tendon ending in the base of the fifth

metatarsal. Young and Robinson (XIV.) state that in the Fox and Dog the peroneus longus is inserted into the cuboid and the 4th and 5th metatarsals. We have examined the insertion very carefully in two Dogs (39, 40), and find that, though the sheath of the tendon is attached to these parts, the tendon itself is continued across the sole, not to the base of the second metatarsal bone, but to that of the rudimentary first.

Peroneus brevis.—This is always present in Carnivora, and rises from the shaft of the fibula below the origin of the peroneus longus. The tendon of insertion, which is large, runs in a groove behind the external malleolus which it shares with the peroneus quinti digiti. It is inserted into the base of the fifth metatarsal bone.

Peroneus quinti digiti.—This is also very constant, although some authors have described it as a slip from the tendon of the peroneus brevis. The muscular belly is very small and easily overlooked; it rises from the upper third or so of the shaft of the fibula, and the delicate tendon passes down in the same groove as that of the peroneus brevis, behind the external malleolus. After reaching the dorsum of the foot, it fuses with the tendon of the extensor longus digitorum to the fifth toe (see fig. 3).

The *Peroneus quarti digiti* is never found in the Carnivora.

Gastrocnemius.—This muscle usually consists of two heads rising from above the two condyles of the femur, though in some cases a third or median head can be separated from the external. In the outer and inner heads fabellæ may be developed, the external one being the more constant; and we have some reason to believe that the ossification of the internal fabella depends on the age of its possessor. The two fleshy bellies unite below the middle of the leg to form the greater part of the tendo Achillis, the fibres of which are twisted in the manner already pointed out by one of us¹. Among the Felidæ, Macalister noticed the presence of a median head in *Felis leo* (1), and Mivart describes four heads to the gastrocnemius of *Felis catus* (9). In *Felis tigris* (4), *Felis pardus* (5, 6), and *Felis pardalis* (8), no median head could be distinguished. Among the Viverridæ only two heads have been recorded. There is always a fabella in the outer head, but in two specimens of *Cryptoprocta* one (13) had an internal fabella and the other (14) had not. In two specimens of *Viverra* (16, 17) the same thing was observed.

In the Canidæ, fabellæ were found in both heads in *Canis familiaris* (39), *Canis aureus* (50 a), and *Canis mesomelas* (51).

In the Ursidæ, Kelley (XXIV.) points out that the gastrocnemius is much smaller in proportion in the Polar Bear than in the Cat. Shepherd (XX.) says that "in *Ursus americanus* (59) the three heads," one of which is evidently the plantaris, "remain distinct as far as their insertion." In Cuvier and Laurillard's specimen of the same animal (62) the two heads unite quite low down in the leg. The Procyonidæ serve very well to show the inconstancy of

¹ "On the Morphology of the Tendo Achillis," by F. G. Parsons. Journ. Anat. vol. xxviii. p. 414.

the internal fabella : in one specimen of *Procyon lotor* (63) it was present, in another (64) it was not. In *Nasua fusca* (69) there were two fabellæ, while in *Nasua narica* (68) only the outer one was seen. Among the Mustelidæ no fabellæ at all were found in *Mustela foina* (79) and *Lutra cinerea* (93), but in *Galictis barbara* (76), *Mustela putorius* (77), *Mustela foina* (80), *Ictonyx* (84), *Meles* (85), and *Lutra* (88) there was an often ill-marked one in the outer head. In the specimen of *Lutra* (88) which we dissected the two heads were separate almost as far as their insertion and resembled very much the condition found in *Castor* (XLI.).

The *Plantaris* rises from the external condyle of the femur and the external fabella, and winds round the inner side of the tendo Achillis till it reaches the calcaneum ; it then usually spreads out into a broad expansion which plays round the posterior surface of the tuberosity of that bone until it reaches the foot, where it is continuous with the flexor brevis digitorum and the plantar fascia. Shepherd, in his specimen of *Ursus americanus* (59), found that the tendon was inserted into the tuber calcis as in man. Watson describes the same arrangement in *Hyæna crocuta* (37), but in no other animals is it recorded.

Soleus.—This muscle rises from the back of the head of the fibula ; it is usually a small muscle and in many cases is absent. As a rule it joins the tendo Achillis in the lower third of the leg, but in some cases is inserted directly into the calcaneum. In the Felidæ and Viverridæ the muscle is present and answers the above description—*Felis leo* (1), *Felis tigris* (4), *Felis pardus* (6), *Felis pardalis* (8), *Cryptoprocta* (13, 14), *Viverra* (16, 17), *Viverricula* (19), *Genetta* (20, 22, 24), *Paradoxurus* (25, 26), *Herpestes* (29, 30), and *Cynictis* (31). *Proteles* in this respect differs from the Viverridæ. The Hyænidæ and Canidæ, with which *Proteles* (32) agrees, are remarkable for the total absence of the soleus—*Proteles* (32), *Hyæna striata* (33, 34, 35, 36), *Hyæna crocuta* (37), *Canis familiaris* (39, 40, 43, 44, 45, 46, 48), *Canis aureus* (50, 50 a), *Canis mesomelas* (51), *Canis lagopus* (53), and *Lycæon pictus* (54). In the Ursidæ, Procyonidæ, and Mustelidæ the soleus is present with the exception of the Otter, in which it seems to be sometimes absent : for instance it was absent in our own specimen (88), while in Haughton's (92) it only weighed 0·01 oz. av. ; in two other specimens (90, 93) it was present and well marked.

Popliteus.—This muscle, which is very constant in the mammalian series, rises from the outer side of the external condyle of the femur and is inserted into the upper third or half of the inner border of the tibia. It was present in every animal examined, and frequently contained a sesamoid bone in its tendon of origin. Perrin (XXIX.) notices that in *Cercoleptes* (74) the anterior tibial artery passed above and then in front of it : we found the same arrangement in a Dog (40), but unfortunately the relations of the artery and muscle have not been observed in any other case.

Flexor fibularis (*F. longus hallucis*).—This rises from the upper

three-quarters of the posterior surface of the fibula, from the interosseous membrane, and often from part of the posterior surface of the tibia. It is the largest of the deep flexor muscles on the back of the leg, and its strong flat tendon passes behind the astragalus and below the sustentaculum tali into the sole, where it is joined by the flexor tibialis tendon (see fig. 4). The conjoined tendons now divide for the toes, always giving off slips for the four outer ones and often for the hallux as well. In the Felidæ, Canidæ, and Hyænidæ no slip is present for the aborted hallux; but in the Viverridæ, Ursidæ, Procyonidæ, and Mustelidæ the hallux receives a slip, though it is often more slender than those to the other digits. In *Herpestes griseus* (30) we found that the slip to the hallux, instead of coming from the combined flexor tendons, was a direct continuation of the accessorius, though in *Herpestes nepalensis* (29) it came from the conjoined tendons as usual (see fig. 4).

Fig. 4.

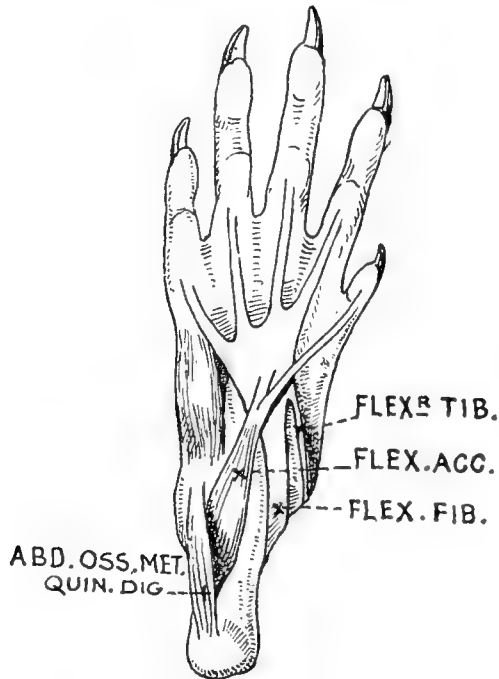
Plantar tendons of foot of *Herpestes*.

Flexor tibialis (*Flexor longus digitorum*).—This rises from the inner part of the posterior surface of the tibia, the fascia over the tibialis posticus, and sometimes from a small part of the back of the upper third of the fibula. The tendon, which is much smaller than that of the flexor fibularis, passes behind the internal malleolus and in the sole joins the inner side of the flexor fibularis, as has already been noticed. The muscle was present and normal in every animal examined.

Lumbricales.—As a rule there are four of these muscles, but

when only three are present the one on the tibial side is missing. Among the Felidæ there are usually three—*Felis leo* (2), *Felis tigris* (4), *Felis pardus* (5, 6), and *Felis pardalis* (8). In one specimen of *Felis leo* (1) Macalister noticed four, two coming from the tendon of the third toe. In the Viverridæ four lumbricales are usually present—*Cryptoprocta* (13), *Viverra* (16), *Genetta* (22, 24), *Herpestes* (30), and *Cynictis* (31). In the following, however, there were only three—*Viverra* (17), *Genetta* (20), and *Proteles* (32). In the Hyænidæ, with which as usual *Proteles* agrees, there are never more than three lumbricales—*Hyæna striata* (33, 34, 35) and *Hyæna crocuta* (37). Young and Robinson state (XIV.) that in *Hyæna striata* (34) the second lumbrical joins the superficial flexor of the second toe, and in Cuvier and Laurillard's plate (XVI.) the same thing seems to occur. The Canidæ have also three lumbricales—*Canis familiaris* (39, 48), *Canis aureus* (50 a), and *Canis mesomelas* (51).

In the Procyonidæ there are usually four lumbricales, but the tibial one is small—*Procyon lotor* (63), *Nasua rufa* (70), *Cercoleptes* (72). In *Procyon lotor* (64) there were only three.

In the Mustelidæ there are also four as a rule—*Mustela foina* (78), *Ictonyx* (84), *Meles* (86), *Lutra* (88, 90). In *Mustela putorius* (77) and *Lutra cinerea* (93) the tibial one was absent.

Tibialis posticus.—This rises from the posterior surface of the tibia below the popliteus and also, sometimes, from a little of the upper part of the back of the fibula; the tendon is very feeble and is inserted into the navicular as a rule, but also into the cuneiforms and bases of the metatarsals. It is present in all the Felidæ and Viverridæ—*Felis leo* (1), *Felis tigris* (4), *Felis pardus* (6), *Felis pardalis* (8), *Felis catus* (9), *Cryptoprocta* (13), *Viverra* (16, 17), *Viverricula* (19), *Genetta* (20, 24), *Paradoxurus* (25, 26), *Herpestes* (29, 30), *Cynictis* (31) (very small), and *Proteles* (32). In the Hyænidæ the muscle may or may not be present; it was absent in one specimen of *Hyæna striata* (33), but present in another (36), while in *Hyæna crocuta* (37) it was absent. In the Canidæ, if the muscle is present at all, it is so feebly developed as to require the greatest care to make it out. Haughton (XVIII.) says that it was absent in two Irish Terriers (41 and another) and a Greyhound (42), while in a Dingo (49) it only weighed 0·01 oz. av. In the Dogs which we dissected (39, 40) we failed to find any trace of it, but in the following it was present although extremely small: 43, 44, 45, 46, 48. In *Canis aureus* (50, 50 a), *Canis mesomelas* (51), and *Canis lagopus* (53), traces of it were found.

In the Ursidæ (58, 59) and Procyonidæ—*Procyon lotor* (63, 64, 65), *Nasua* (68, 69), *Cercoleptes* (72, 73, 74)—it was present, and in *Procyon lotor* (63) a sesamoid cartilage was found in the tendon where it passed under (plantar to) the short plantar ligament. Among the Mustelidæ the tibialis posticus was present in *Galictis vittata* (75), *Galictis barbara* (76), *Mustela putorius* (77), *Mustela foina* (79), *Ictonyx libyca* (84), *Meles* (85, 86), and *Lutra* (88, 93).

Peroneo-tibialis.—This muscle has been noticed by Gruber (XLVIII.) as being present in 24 out of 30 specimens of *Canis familiaris* as well as in *Canis lupus* and *Canis vulpes*. No other author, to our knowledge, has noticed its presence in the Carnivora. Unfortunately, we only came across Gruber's paper after our animals, with seven exceptions, were dissected, though we feel confident that if the muscle had been at all well developed it would not have escaped our notice. The seven animals which we specially examined without finding the slightest trace of a peroneo-tibialis were *Cryptoprocta* (14), *Cynictis* (31), *Herpestes griseus* (30), *Canis aureus* (50 a), *Canis mesomelas* (51), *Nasua narica* (an extra specimen), and *Cercoleptes* (72). We also procured an additional specimen of *Canis familiaris* and made an extremely careful examination of the posterior tibial region. We are confident that there were no muscular fibres deep to the popliteus passing between the tibia and fibula and corresponding to the rotator fibulæ so well known in the Lemuroidea. Lower down in the leg, however, we came across a few very delicate strips of muscle passing transversely from one bone to the other and with the greatest difficulty separable from the origin of the flexor fibularis. The nerve-supply of these seemed to be from the anterior tibial. We fear that the question of the presence of this muscle throughout the Carnivora must remain for future investigation.

Flexor brevis digitorum.—This muscle is in most cases a direct continuation of the plantaris after the latter has passed round the back of the tuber calcis. It usually has a fleshy belly in the sole, which divides into four slips; these soon become tendinous and form the flexores perforati for the four outer toes. Just before the deep tendons pass through them a fibrous ring is given off which surrounds the deep tendons. Each slip of the flexor brevis, after having been perforated, unites and divides again to be inserted into the middle phalanx. In some cases muscular slips are given off in the sole from the conjoined deep tendons to those of the flexor brevis; these have already been noticed in *Hyæna striata* as displaced lumbricales. The Hyænidæ and Canidæ are remarkable for the absence of muscular fibres in the flexor brevis, which is therefore a mere expanded, fibrous continuation of the plantaris tendon. This arrangement was noticed in *Hyæna striata* (33, 35), *Proteles* (32), *Canis familiaris* (39, 40), *Canis aureus* (50, 50 a), *Canis mesomelas* (51), and *Canis lagopus* (53). In *Hyæna crocuta* (37) there was not only no fleshy belly to the flexor brevis, but that muscle was not continuous with the plantaris, which ended in the tuber calcis. Kelley (XXIV.) noticed that in *Ursus maritimus* (55) the flexor brevis was only fleshy for the 2nd and 3rd toes, the tendons for the 4th and 5th being continuous with the plantaris. In *Ursus americanus* (59) the flexor brevis rose entirely from the calcaneum, though in the other Bears (55, 57, 58, 62) the usual arrangement existed. In one specimen of *Viverra* (17), Macalister found no tendon to the outermost toe.

Accessorius.—This muscle is usually present in the Carnivora; it rises from the under and outer side of the calcaneum and is inserted into the conjoined tendons of the flexores fibularis and tibialis, usually on their plantar surface. In the Felidæ it is short and transverse—*Felis leo* (1, 2), *Felis tigris* (4), *Felis pardus* (5, 6), *Felis pardalis* (8), *Felis catus* (10). In the Viverridæ it is also present but is more antero-posterior: in many instances the innermost fibres of the muscle were continued on into the hallux; this was the case in *Cryptoprocta* (13, 14), *Viverra* (16), *Genetta* (24), *Paradoxurus* (25), and *Herpestes* (29). In *Herpestes* (30), as we have already mentioned under the head of the flexor fibularis, the accessorius formed the whole of the only flexor tendon to the hallux (see fig. 4).

Fig. 5.

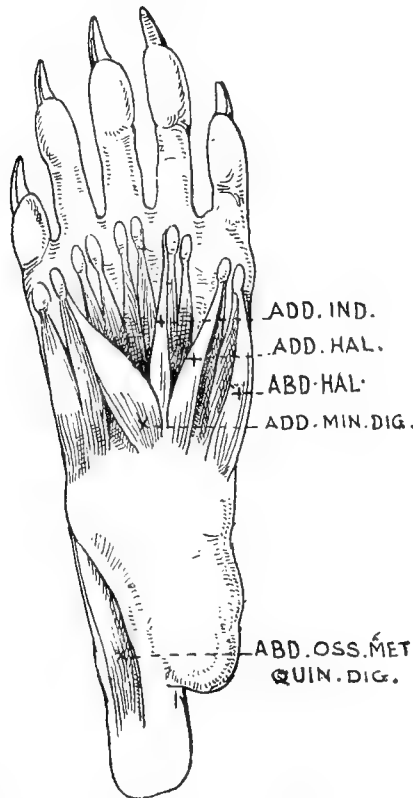
Plantar muscles of foot of *Procyon*.

Among the Hyænidæ the muscle was absent in *Hycena striata* (33, 36), and also in *Proteles* (32), but it was found in *Hycena crocuta* (37). The Canidæ are remarkable for the frequency with which this muscle is absent: this was the case in *Canis familiaris* (39, 40, 43, 44, 45, 46, 48), *Canis aureus* (50), *Canis mesomelas* (51), and *Canis lagopus* (53). In *Canis aureus* (50 a) and *Lycaon pictus* (54) the accessorius was present. In the other families

the muscle was present in every case, and calls for little notice except that it tends to form a large part of the long tendon for the hallux.

Abductor ossis metatarsi quinti.—This muscle was frequently noticed: when present it rises from the posterior part of the calcaneum and is inserted into the base of the fifth metatarsal bone. In some cases a slip was continued on to the base of the proximal phalanx of the fifth toe, forming a feeble abductor minimi digiti, but more often it was absent (see fig. 5).

Abductor hallucis.—This is usually present in the families in which the hallux is not aborted (see fig. 5). In the Felidæ, Canidæ, and Hyænidæ it is absent.

Fig. 6.

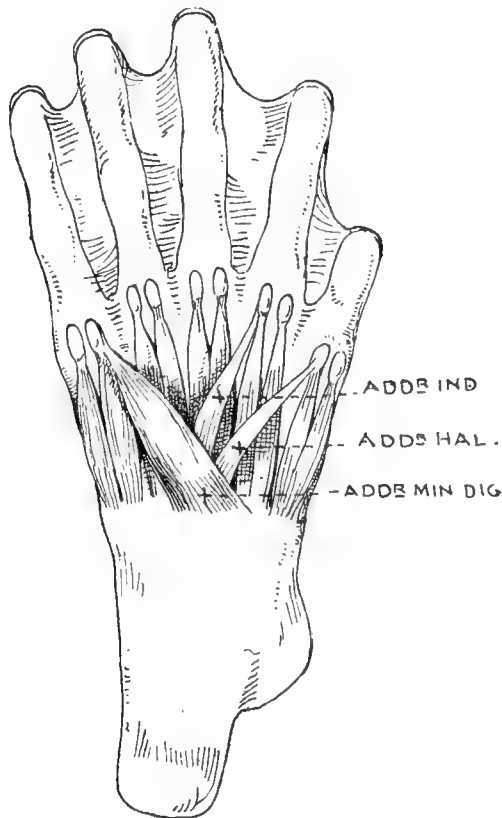
Muscles of sole of foot of *Lutra*.

Adductor Muscles of the Foot. First Layer of Deep Muscles.—As in the hand, the usual arrangement is to find three adductors—one for the hallux, one for the index, and a third for the minimus (see figs. 5 & 6). As the hallux is suppressed in the Felidæ, Canidæ, and Hyænidæ, there is, of course, no adductor hallucis in these families. In *Felis pardus* (6) and *pardalis* (8) there were two adductors of the fifth digit. In *Viverra* (17) Macalister found an

adductor of the annularis instead of the index, but in *Viverricula* (19) the arrangement was normal.

Second Layer of Deep Foot Muscles.—A double-headed flexor brevis was found in each toe in all the specimens examined (see fig. 6). Of course in the Felidæ, Hyænidæ, and Canidæ the muscle for the hallux was absent.

Third Layer of Deep Foot Muscles.—In no animal could we find any muscles dorsal to the ones last described. Allen, too, looked for them in *Procyon* (64, 65), and Young and Robinson in *Hyæna* (33), but without success.

Muscles of the Trunk.

Rectus ventralis (Rectus abdominis).—This muscle rises from the pubic symphysis and runs forwards to be inserted into several of the anterior ribs at their junction with the sternum, the insertion into the first rib being always the best marked. In *Canis familiaris* (39) we noticed that the fleshy part of the muscle ended opposite the 6th rib cartilage, anterior to which it was continued by a fibrous sheet to the first rib. (See Part I. of this paper, P. Z. S. 1897, p. 382, fig. 6.) In *Hyæna striata* (35) the same arrangement existed. The lineæ transversæ may be quite evident or so indistinct as to be overlooked: there are usually between 5 and 8 of them, but they are not constant in two individuals of the same species; for instance, Testut (XXIII.) noticed eight in *Ursus americanus*, while Meckel (XXXIX.) and Cuvier and Laurillard (XXII.) only found five in the same animal. Five, however, seems to be the commonest number.

The *Pyramidalis* is seldom sufficiently well-marked to be noticed as a distinct muscle. In most of the animals which we dissected it was looked for and found closely incorporated with the rectus. Murie (XVII.) describes it as wanting in *Hyæna brunnea*, as do also Young and Robinson (XIV.) in *Hyæna striata* and Alix (XXX.) in *Mustela putorius*. Shepherd, however, says that it is large and distinct in *Ursus americanus*.

Supracostalis.—There can be little doubt that this muscle is a continuation forward of the external oblique plane; it is very constant in the Carnivora, and was found in every animal in which it was looked for. It rises from the sternum at the junction of the 2nd and 3rd costal cartilages, and runs outward and forward to be inserted into the first rib about the middle. Some of its fibres are occasionally continued into the scalenus brevis.

The *External Oblique* rises from the posterior 8 to 10 ribs by separate digitations, and the muscle runs inward and backward to the symphysis and linea alba; it is easily separable from the surface of the rectus ventralis in the posterior part of the abdomen, but less easily in the anterior. In the dorsal part of the abdominal wall it is continuous with the lumbar aponeurosis, and there is no fleshy insertion into the crest of the ilium. In *Ictonyx libyca* (84) we noticed double digitations from the posterior two or three ribs.

The *Internal Oblique* rises from the lumbar fascia, the crest of

the ilium, and Poupart's ligament. It is inserted into the posterior two to five ribs and the linea alba.

We have noticed in several animals that the aponeurosis of this muscle, instead of dividing to enclose the rectus, passes superficially to it, and Shepherd (XX.) has observed the same in *Ursus americanus*. In male Carnivora the internal oblique forms, at all events, the greater part of the scrotal pouch.

The *Transversalis* rises from the internal surfaces of the posterior six or more ribs and from the lumbar fascia; it is only fleshy in the dorsal and anterior part of the abdomen. In some animals it splits to enclose the rectus, but it is difficult in many cases to be sure of this point.

The *Psoas magnus* rises from the posterior three or four thoracic and all the lumbar vertebræ. It is joined by the iliacus and inserted into the lesser trochanter.

The *Psoas parvus* is always present in Carnivora, it rises from the anterior lumbar vertebræ, internal to the magnus, and is inserted into the ilio-pectineal line.

The *Iliacus* is always a small muscle, and has the usual origin from the venter of the ilium. Its insertion is with the psoas.

Quadratus lumborum.—This muscle is very difficult to distinguish, as it tends to fuse with the psoas ventrally and the erector spinæ dorsally; it usually consists of fibres running from the lumbar transverse processes to the crest of the ilium, the costo-vertebral portion being undifferentiated.

Serrati dorsales.—These muscles show great variety in the number of ribs to which they are attached, as well as in the degree of their fleshy development. They also vary in the number of ribs to which they are attached in different specimens of the same animal. For these reasons we think it needless to encumber this paper with the exact number of attachments in each animal dissected, but will content ourselves with saying that the serratus dorsalis thoracis (serratus posticus superior of human anatomy) is always a larger muscle than the serratus dorsalis lumbalis (serratus posticus inferior), and that it is usually attached to some 8 or 10 ribs, beginning at the 2nd or 3rd. The serratus dorsalis lumbalis, on the other hand, is small and is often absent altogether. When it is present, it is attached to three or four posterior ribs, and in those cases in which the two muscles overlap, it is always the lumbalis which is superficial. In Cuvier and Laurillard's plate of the Badger's muscles (XXXIII.), the lumbar part of the serratus dorsalis is inserted into the eight anterior ribs and no thoracic portion is present. Unfortunately we have not had an opportunity of checking this observation.

Erector spinæ.—The three portions of this mass known in human anatomy as the sacro-lumbalis, longissimus dorsi, and spinalis dorsi are present in the Carnivora. In *Felis leo* and *Felis pardus*, Cuvier and Laurillard (V., VI.) point out that the sacro-lumbalis is not continued back as far as the sacrum and ilium, but only reaches the rib. In these animals, apparently, only that part of

the outer layer corresponding to the human accessorius is present. In no case have we been able to satisfy ourselves that the sacro-lumbalis and accessorius are continued up into the neck as the cervicalis ascendens. The longissimus dorsi is continued up to the dorsal tubercles of the transverse processes of the posterior five or six cervical vertebræ as the transversalis colli.

The *Transversalis capitis* (*Trachelo-mastoid*) is always present in the Carnivora; it is practically a continuation forward of the longissimus dorsi. It rises from the posterior three or four cervical and the anterior one or two thoracic vertebræ, and is inserted into the skull deep to the outermost fibres of the splenius capitis. In *Ursus americanus* (60) a slip is given from it to the transverse process of the atlas. In *Ictonyx libyca* (84) and *Lutra vulgaris* (88) we noticed that the trachelo-mastoid was distinctly bilaminar with the ventral margins fused. Sometimes the muscle has a tendinous intersection running across it, but this is not nearly so frequently the case as in the complexus.

Complexus.—The mesial part of the complexus which, in human anatomy, is called biventer cervicis is always marked off from the lateral part or complexus proper; it rises from the anterior two or three thoracic vertebræ, and usually has from one to four transverse intersections in its course. The lateral part of the complexus rises from the anterior one or two thoracic and the posterior four cervical vertebræ; it sometimes has one or two intersections, but they are never as numerous so in the complexus mesialis. As it approaches its insertion into the occipital bone the muscle usually becomes tendinous. In certain of the Carnivora, e. g. *Felis catus* (9) and *Ursus maritimus* (55), a complexus tertius has been noticed, lying externally to the rest, rising from the 2nd, 3rd, and 4th cervical vertebræ, and being inserted into the transverse process of the atlas.

Suboccipital triangle.—The muscles of this triangle call for little remark, except to notice that the rectus capitis dorsalis (posticus) major is divided into a superficial and a deep layer. This arrangement is common in other animals besides the Carnivora, and we have proposed to describe three dorsal recti of the head, and to name them superficialis, medius, and profundus, the latter corresponding to the rectus capitis posticus minor of human anatomy.

The *Splenius capitis* is a very constant muscle rising from the ligamentum nuchæ and anterior thoracic spines, and being inserted into the curved line of the occipital bone.

The *Splenius colli* is usually absent in Carnivora. In *Hycena striata* (33), however, Young and Robinson found it, and Cuvier and Laurillard represent it as a very large muscle in the same animal (35). In *Hycena crocuta* (37) and *Proteles* (32), on the other hand, Watson says that the muscle is absent. In two Dogs, of which we have records (39, 48), there was no splenius colli; while among the Viverridæ it was noticed by Young in one specimen of *Viverra civetta* (16), but not by Macalister and Meckel in other specimens of the same animal. Among the Felidæ, Ursidæ,

Procyonidæ, and Mustelidæ the muscle has, so far as we know, not been observed except in *Lutra cinerea* (93), in which Macalister describes it as feeble.

Myological Characteristics of the various Families of Carnivora.

FELIDÆ.

- (1) Sterno-mastoids of opposite sides do not fuse in the mid-ventral line.
- (2) The omo-hyoid is never present.
- (3) The cephalo-humeral usually reaches the forearm.
- (4) The pronator radii teres is inserted into the middle of the radius.
- (5) The palmaris longus externus alone is present.
- (6) The pronator quadratus occupies the lower half of the radius and ulna.
- (7) The supinator longus is present (except in *Cynælurus*).
- (8) The flexor brevis digitorum manûs is usually present.
- (9) The caudo-femoralis (agitator caudæ) usually reaches the patella.
- (10) The ilio-tibialis (sartorius) is usually single.
- (11) The semitendinosus never has a caudal head.

VIVERRIDÆ.

- (1) The sterno-mastoids of opposite sides seldom fuse.
- (2) The omo-hyoid is seldom present.
- (3) The rhomboideus capitis is seldom seen.
- (4) The subclavius is sometimes present.
- (5) The cephalo-humeral usually reaches the forearm.
- (6) The pronator radii teres is inserted into the middle of the radius.
- (7) There may be a palmaris longus externus, internus, or both.
- (8) The pronator quadratus is very variable.
- (9) The supinator longus is present.
- (10) The flexor brevis digitorum manûs is often present.
- (11) The caudo-femoralis is inserted into the lower third of the femur.
- (12) The ilio-tibialis (sartorius) may be single or double.
- (13) The semitendinosus always has a caudal head.

HYÆNIDÆ.

- (1) The mylo-hyoid does not reach as far forward as the symphysis menti.
- (2) The omo-hyoid is usually absent.
- (3) The rhomboideus capitis is seldom present.
- (4) The cephalo-humeral is inserted into the humerus.
- (5) The pronator radii teres is inserted into the middle of the radius.

- (6) The *palmaris longus externus* alone is present.
- (7) The *flexor profundus digitorum* does not usually send a slip to the pollex.
- (8) The *pronator quadratus* occupies the whole length of the radius and ulna.
- (9) The *supinator longus* is absent.
- (10) The *flexor brevis digitorum manûs* is rarely present.
- (11) The *caudo-femoralis* is absent.
- (12) The *ilio-tibialis* is double.
- (13) The *semitendinosus* never has a caudal head.
- (14) The *soleus* is absent.
- (15) The *flexor brevis digitorum pedis* has no fleshy belly in the sole.
- (16) The *tibialis posticus* is often absent.
- (17) The *accessorius* is often absent.

CANIDÆ.

- (1) The *mylo-hyoid* does not reach the *symphysis menti*.
- (2) The *omo-hyoid* is always absent.
- (3) The *rhomboideus capitis* is always present.
- (4) The *cephalo-humeral* is inserted into the humerus.
- (5) The *pronator radii teres* is usually inserted above the middle of the radius.
- (6) The *palmaris longus* is usually absent.
- (7) The *pronator quadratus* occupies the whole length of the radius and ulna.
- (8) The *supinator longus* is absent.
- (9) The *flexor brevis digitorum manûs* is absent.
- (10) The *caudo-femoralis* is absent.
- (11) There is no *gluteus ventralis* (*quartus*).
- (12) The *ilio-tibialis* is usually double.
- (13) The *semitendinosus* never has a caudal head.
- (14) The *soleus* is absent.
- (15) The *tibialis posticus* is absent or very rudimentary.
- (16) The *flexor brevis digitorum pedis* has no fleshy belly in the sole.
- (17) The *accessorius* is usually absent.

URSIDÆ.

- (1) The *omo-hyoid* is always present.
- (2) The *rhomboideus capitis* may or may not be present.
- (3) The *cephalo-humeral* is inserted into the humerus.
- (4) The *flexor longus cubiti* (*biceps*) is almost always *bicipital*.
- (5) The *coraco-brachialis longus* is present.
- (6) The *pronator radii teres* is inserted into the lower end of the radius.
- (7) The *palmaris longus* is often absent.
- (8) The *pronator quadratus* is attached to the lower third of the radius and ulna.
- (9) The *supinator longus* is present.

	<i>Felidae.</i>	<i>Viverridae.</i>	<i>Hyenidae.</i>	<i>Canidae.</i>	<i>Ursidae.</i>	<i>Procyonidae.</i>	<i>Mustelidae.</i>
Sterno-mastoid fusing in mid line.	Never.	Seldom.	Often.	Often.	Often.	Often.	Often.
Omo-hyoid	Absent.	Seldom present.	Usually absent.	Absent.	Present.	Usually absent.	Usually present.
Insertion of Cephalo-humeral.	Usually fore-arm.	Usually fore-arm.	Humerus.	Humerus.	Humerus.	Humerus.	Humerus.
Rhomboides capitis...	Present.	Usually absent.	Usually absent.	Present.	Present or absent.	Present.	Present.
Rhomboides profundus as a distinct muscle.	Absent.	Absent.	Absent.	Absent.	Absent.	Sometimes present.	Always present.
Flexor longus cubiti (Biceps).	One head.	Almost always one head.	One head.	One head.	Two heads.	Sometimes two heads.	One head.
Coraco-brachialis medius and longus.	Absent.	Absent.	Absent.	Absent.	Present.	Sometimes present.	Sometimes present.
Subclavius	Absent.	Sometimes present.	Absent.	Absent.	Absent.	Absent.	Absent.
Head of Extensor cubiti (Triceps) from angle of scapula.	Absent.	Absent.	Absent.	Absent.	Absent.	Absent.	Present.
Pron. radii teres insertion.	Mid. of radius.	Middle.	Middle.	Above middle.	Lower end.	Lower end.	Lower end.
Palmaris longus	Externus.	Extern., intern., or both.	Externus.	Neither.	Both often absent.	Both usually present.	Externus.

2 Heads of Fl. carpi ulnaris.	Join high up.	Inconstant.	Remain distinct.	Remain distinct.	Remain distinct.	Usually join high up.	Inconstant.
Pollex tendon of Fl. prof. dig.	Present.	Absent.	Present.	Present.	Present.	Present.	Present.
Pronator quadratus ...	Lower $\frac{1}{2}$ of forearm.	Whole length.	Whole length.	Whole length.	Whole length.	Variable.	Variable.
Supinator longus	Present (except <i>Cynelurus</i>).	Absent.	Absent.	Absent.	Present.	Present.	Present.
Fl. br. dig. manus ...	Present.	Usually absent.	Absent.	Absent.	Usually absent.	Usually present.	Seldom present.
Agitator caudæ (caudofemoralis).	Present (usually reaches patella).	Absent.	Absent.	Absent.	Absent.	Present or absent.	Present or absent.
Gluteus ventralis (G. quartus).	Usually present.	Present or absent.	Usually present.	Usually present.	Usually present.	Usually absent.	Usually present.
Ilio-tibialis (Sartorius)	Usually single.	Double.	Usually double.	Usually double.	Usually double.	Usually single.	Usually single.
Semitendinosus (caudal head).	Never present.	Never present.	Never present.	Never present.	Never present.	Always present.	Present or absent.
Soleus.....	Present.	Absent.	Absent.	Absent.	Absent.	Present.	Present.
Tibialis posticus	Present.	Often absent.	Usually absent.	Usually absent.	Usually absent.	Present.	Present.
Fl. brev. dig. pedis.	Present.	Absent.	Absent.	Absent.	Absent.	Present.	Present.
Accessorius pedis	Present.	Absent.	Absent.	Absent.	Absent.	Present.	Present.

- (10) The supinator brevis occupies the upper three quarters of the radius.
- (11) The flexor brevis digitorum manûs is usually absent.
- (12) The caudo-femoralis is absent.
- (13) The ilio-tibialis is usually single.
- (14) The semitendinosus never has a caudal head.

PROCYONIDÆ.

- (1) The omo-hyoid is usually absent (it is present in *Cercoleptes*).
- (2) The rhomboideus profundus is sometimes present (*Cercoleptes*).
- (3) The rhomboideus capitis is always present.
- (4) The cephalo-humeral is inserted into the humerus.
- (5) The flexor longus cubiti (biceps) is sometimes bicipital.
- (6) The pronator radii teres is usually inserted into the lower end of the radius.
- (7) Both palmaris longus externus and internus are usually present.
- (8) The pronator quadratus is variable.
- (9) The supinator longus is present.
- (10) The flexor brevis digitorum manûs is usually present.
- (11) The caudo-femoralis may be present or absent.
- (12) The ilio-tibialis is usually single.
- (13) The semitendinosus always has a caudal head.

MUSTELIDÆ.

- (1) The omo-hyoid is usually present.
- (2) The rhomboideus profundus is always present.
- (3) The rhomboideus capitis is always present.
- (4) The cephalo-humeral is inserted into the humerus.
- (5) The triceps has an extra head from the angle of the scapula.
- (6) The pronator radii teres is usually inserted into the lower end of the radius.
- (7) There is usually only a palmaris longus externus.
- (8) The pronator quadratus is variable.
- (9) The supinator longus is present.
- (10) The flexor brevis digitorum manûs is usually absent.
- (11) The caudo-femoralis may be present or absent.
- (12) The ilio-tibialis is usually single.
- (13) The semitendinosus may or may not have a caudal head.

With the view of making the characteristics of the various families more evident, we have arranged them in a tabular form (see pp. 180, 181).

We propose to close this paper with an examination of how far the study of the muscles helps towards determining the position of one or two of the Carnivora the affinities of which are somewhat doubtful. In the first place, the Cheetah (*Cynælurus jubatus*) is known to differ from the rest of the Felidæ in having only partially retractile claws and a carnassial tooth without an inner lobe. When one examines its muscular structure one notices that in

many respects it more closely approaches the Canidæ than the Felidæ. The following are the chief Feline characteristics:—

- (1) The ilio-tibialis (sartorius) is single.
- (2) The caudo-femoralis (agitator caudæ) reaches the patella.
- (3) The gluteus ventralis (quartus) is present.

The following are the chief Canine characteristics:—

- (1) The pronator quadratus reaches as far as the oblique ligament, *i. e.* to close to the top of the radius and ulna.
- (2) The supinator longus is absent.
- (3) Only the tendon of the tibialis posticus is present.
- (4) The accessorius is absent.
- (5) The flexor brevis digitorum pedis has no muscular fibres in the sole.

The following two points are common to both Felidæ and Canidæ, but go to show that the animal has no Viverrine tendencies:—

- (1) The subclavius is absent.
- (2) The semitendinosus has no caudal head.
- (3) The rhomboideus capitis is present.

We should like to emphasize the fact that we have never had an opportunity of dissecting a specimen of *Cynelurus*, and that our facts are gained from Ross's description. This is in some ways an advantage because his account is an absolute statement of facts set down without any view of proving a theory; it is a disadvantage because there are many points on which we would like detailed information which necessarily seemed of little or no importance to him.

The Fossa (*Cryptoprocta ferax*) of Madagascar is another animal about whose position systematists are not quite agreed. We have dissected two specimens of this animal (13, 14), and Beddard (VII.) has published some notes on the myology of a third. So far as its muscles go we regard it as a most typical viverrine animal, and the three specimens of which we have records agree so well that we feel that we can speak with some confidence on its myology.

The Aard Wolf of South Africa (*Proteles cristatus*) has been placed, in our list of animals, at the end of the Viverridæ in deference to what we believe is the view of most systematists at the present time; its muscles, however, point to its much closer relationship with the Hyænidæ, and we subjoin the facts on which our opinion is based:—

α. Viverrine tendencies.

- (1) The cephalo-humeral is inserted into the forearm.
- (2) There is a tendon to the pollex from the flexor profundus digitorum.

β. Hyænine tendencies.

- (1) The pronator quadratus occupies the whole length of the forearm.

- (2) The supinator longus is absent.
- (3) The caudo-femoralis (agitator caudæ) is absent.
- (4) The ilio-tibialis (sartorius) is double.
- (5) The semitendinosus has no caudal head.
- (6) There is no soleus.
- (7) There is no fleshy flexor brevis digitorum pedis.
- (8) There is no accessorius pedis.

The South-American Kiukajou (*Cercoleptes caudivolvulus*) is an animal of which we have had the good fortune to dissect two specimens. It is usually looked upon as a typical member of the Procyonidæ, but we have detected two important musteline characteristics in its muscles and one which is distinctly ursine.

Its Musteline tendencies are :—

- (1) The presence of the omo-hyoid.
- (2) The presence of a distinct rhomboideus profundus.

Its Ursine characteristic is :—

- (1) The presence of two heads to the flexor longus cubiti (biceps).

The points characteristic of the Procyonidæ are :—

- (1) The presence of two palmares longi.
- (2) The fusion of the two heads of the flexor carpi ulnaris.
- (3) The absence of a head from the angle of the scapula to the extensor longus cubiti (triceps).
- (4) The presence of the flexor brevis digitorum manûs.

Other myological points of interest are :—

- (1) The pronator radii teres is inserted into the lower end of the radius (common to Ursidæ, Procyonidæ, and Mustelidæ).
- (2) The supinator longus is present (common to Ursidæ, Procyonidæ, and Mustelidæ).
- (3) The caudo-femoralis (agitator caudæ) is present (common to Procyonidæ and Mustelidæ).
- (4) The gluteus ventralis (quartus) is present and distinct (common to Ursidæ and Mustelidæ, not to other Procyonidæ).
- (5) The ilio-tibialis (sartorius) is single (common to Ursidæ, Procyonidæ, and Mustelidæ).
- (6) The semitendinosus has a caudal head (common to Procyonidæ and Mustelidæ).

BIBLIOGRAPHY.

- I. MIVART.—‘The Cat.’ London, J. Murray, 1881.
- II. STRAUS-DURCKHEIM.—‘Anatomie descriptive et comparative du Chat.’ T. ii., 1845.
- III. HAUGHTON.—‘Muscles of the Lion.’ P. R. I. A. vol. ix. p. 85.
- IV. ROSS.—‘*Felis jubata*.’ P. R. I. A. ser. 2, vol. iii. p. 23.
- V. CUVIER & LAUBILLARD.—‘La Lionne.’ Planches de Myologie, Pls. 143–155.

- VI. CUVIER & LAURILLARD.—“La Panthère.” Planches de Myologie, Pls. 166–168.
- VII. BEDDARD.—“*Cryptoprocta ferox*.” P. Z. S. 1895, p. 430.
- VIII. YOUNG.—“*Viverra civetta*.” J. Anat. vol. xiv. p. 166.
- IX. MACALISTER.—“Civet and Tayra.” P. R. I. A. ser. 2, vol. i. p. 506.
- X. DEVIS.—“*Viverra civetta*.” Journ. Anat. vol. ii. p. 205.
- XI. MIVART.—“On the *Eluroidea*.” P. Z. S. 1882, p. 459.
- XII. CUVIER & LAURILLARD.—“Genette commune.” Planches de Myologie, Pls. 124–128.
- XIII. WATSON.—“*Proteles lalandii*.” P. Z. S. 1882, p. 579.
- XIV. YOUNG & ROBINSON.—“*Hyæna striata*.” Journ. Anat., 1889.
- XV. WATSON & YOUNG.—“*Hyæna crocuta*.” P. Z. S. 1879, p. 79.
- XVI. CUVIER & LAURILLARD.—“Hyène rayée.” Planches de Myologie, Pls. 129–142.
- XVII. MURIE.—“*Hyæna brunnea*.” Tr. Z. S. vol. vii. p. 511.
- XVIII. HAUGHTON.—“Dingo compared with other Dogs.” P. R. I. A. 1867, p. 504.
- XIX. CUVIER & LAURILLARD.—“Le Chien.” Planches de Myologie, Pls. 112–125.
- XX. SHEPHERD.—“American Black Bear.” Journ. Anat. vol. xviii. p. 103.
- XXI. HAUGHTON.—“Virginian Bear.” P. R. I. A. vol. ix. p. 508.
- XXII. CUVIER & LAURILLARD.—“L'Ours noir d'Amérique.” Planches de Myologie, Pls. 81–93.
- XXIII. TESTUT.—“Les anomalies musculaires chez l'Homme expliquées par l'anatomie comparée.” Paris, 1884.
- XXIV. KELLEY.—“Polar Bear.” Proc. Ac. Nat. Sci. of Philad. no. 1, p. 48.
- XXV. WINDLE.—“*Procyon cancrivorus*.” Journ. Anat. vol. xxiii. p. 81.
- XXVI. ALLEN.—“*Procyon lotor*.” Proc. Ac. Nat. Sci. of Philad. 1882, p. 115.
- XXVII. MACKINTOSH.—“*Nasua narica* and *Mustela foina*.” P. R. I. A. ser. 2, vol. ii. no. 1, p. 48.
- XXVIII. CUVIER & LAURILLARD.—“Le Coati Roux.” Planches de Myologie, Pls. 94–99.
- XXIX. PERRIN.—“*Cercoleptes*.” P. Z. S. 1871, p. 547.
- XXX. ALIX.—“*Putorius communis*.” Journ. de Zoologie, vol. v. p. 152.
- XXXI. CUVIER & LAURILLARD.—“La Fouine.” Planches de Myologie, Pls. 104–107.
- XXXII. HAUGHTON.—“*Meles taxus*.” P. R. I. A. vol. ix. p. 507.

- XXXIII. CUVIER & LAURILLARD.—“Le Blaireau d'Europe.”
Planches de Myologie, Pls. 100–103.
- XXXIV. HAUGHTON.—“*Lutra vulgaris*.” P. R. I. A. vol. ix.
p. 511.
- XXXV. CUVIER & LAURILLARD.—“La Loutre.” Planches de
Myologie, Pls. 108–111.
- XXXVI. LUCÆ.—“*Lutra vulgaris*.” Abhandl. d. Senckenb.
Gesellschaft, Bd. ix.
- XXXVII. MACALISTER.—“*Aonyx leptonyx*.” P. R. I. A. n. ser.
vol. i. p. 539.
- XXXVIII. DIECK.—“*Canis vulpes*.” Zeitschr. f. d. gesammte
Naturwiss. Bd. xxxi. p. 218.
- XXXIX. MECKEL.—“Anatomie Comparée.” Tome vi.
- XL. PAGENSTECHEK.—“*Lycaon pictus*.” Zoologischer
Garten, Jahrg. 1870, p. 238.
- XLI. PARSONS.—“Myology of Rodents.” P. Z. S. 1894,
p. 251.
- XLIIa. PARSONS.—“Myology of Rodents.” P. Z. S. 1896,
p. 159.
- XLII. PARSONS.—“Possible Sternalis in *Bathyergus*.” P.
Anat. Soc. Feb. 1895, p. xi.
- XLIII. GILIS.—“Anatomy of Scalenes in Ruminants, Solipeds,
and Carnivora.” Comptes Rendus, ser. 9, tome iv.
no. 20, p. 464.
- XLIV. WINDLE.—“Deep Flexor mass of Forearm.” Journ.
Anat. vol. xxiv. p. 72.
- XLV. WINDLE.—“Adductor Muscles of the Hand.” P.
Birm. Phil. Soc. vol. v. pt. 2, no. 12.
- XLVI. CUNNINGHAM.—“Report on the Marsupialia.” Chal-
lenger Reports, vol. v. pt. 16, p. 19.
- XLVII. WINDLE.—“Pectoral Group of Muscles.” Trans.
R. I. Acad. xxix. p. 345.
- XLVIII. RUGE.—“Morph. Jahrbuch.” Bd. iv.

4. On the Lepidopterous Insects collected by Mr. G. A. K.
Marshall in Natal and Mashonaland in 1895 and 1897.
By ARTHUR G. BUTLER, Ph.D., F.L.S., F.Z.S., &c.,
Senior Assistant-Keeper, Zoological Department, British
Museum.

[Received February 25, 1898.]

(Plate XX.)

The consignment of which the following is an account was received too late to be noticed in my previous paper (P. Z. S. 1897, p. 835); it is, in some respects, of even greater interest, as including not only examples of several interesting new species and of many species new to the Museum series, but also the seasonal forms, authenticated by the donor, of a fair number of

butterflies which have been regarded as distinct, and the varietal character of which is still called in question by some of the leading lepidopterists in this country.

Speaking of the series from Mashonaland, Mr. Marshall observes:—"My Mashonaland collections, which I had intended to take home with me, have only just arrived here (or rather half of them), having been fourteen months coming down from Salisbury! I find among the *Teracoli* a single dry-season male of *T. hildebrandti* (which at the time I took to be a sport of *T. annæ*) and also a female of *T. pallene*, Hopff., which is almost identical with the figure of your *T. infumatus*.

"You will find three males and one female of a '*Lycæna*' from the Karkloof, which Trimen considers to be only a variety of his *L. niobe*, but which I think is probably specifically distinct. It was discovered by Hutchinson and Barker in 1892 on Mr. Ball's farm in the Karkloof District near Maritzburg, and has apparently never been taken elsewhere. From their account (I have never seen it in life) it differs much in habits from typical *L. niobe*. It has been found only within a very limited area, a few acres in extent, flying rapidly over a patch of very long rank grass along the outskirts of a clump of forest, and being on the wing only in autumn (viz. March and April).

"*L. niobe* is distributed throughout Natal (it varies above in being either blue or brown), frequenting open country with short grass, and flying with a low, rapid flight; it occurs only during the spring months.

"It will be unnecessary to point out the differences in colouring, the most noticeable of which are the different position of the discal row on underside of secondaries and the presence of the metallic-green spot at anal angle in the 'variety.' I am sorry that the specimens are in such poor condition; they were given to me by Mr. Ball."

Mr. Marshall did not forward the male of "*T. hildebrandti*," but it probably is what he at first supposed—a mere sport of *T. annæ*, corresponding in colouring with the *T. calliclea* (= *hildebrandti*) form of the Nyasa species. The two species are very closely related—little more than local forms, in fact.

As regards the "*Lycæna*," I quite agree with Mr. Marshall that it requires a distinctive name; it certainly is not identical with *Catochrysops niobe*, but is a finer and more brightly coloured species.

The following is a list of the species received in Mr. Marshall's last consignment:—

N Y M P H A L I D Æ.

SATYRINÆ.

1. SAMANTA PERSPICUA (var. SIMONSI Butl.).

Mazoe, 4000 feet, 30th October, 1894; Gadzima, 4200 feet, Umfuli River, Mashonaland, 30th July, 1895.

2. MYCALESIS SELOUSI Trim.

Enterprise Camp, near Salisbury, 5000 feet, Mashonaland,
23rd June and 2nd July, 1895.

New to the Museum collection.

3. YPTHIMA DOLETA Kirby.

Wet form. Salisbury, 5000 feet, 2nd December, 1894.

Dry form. Gadzima, 4200 feet, 7th August, 1895.

4. YPTHIMA MASHUNA Trim.

Salisbury, 5000 feet, Mashonaland, 17th and 24th March, 1895.

New to the Museum collection.

5. PSEUDONYMPHA VIGILANS Trim.

Salisbury, ♂ 10th, ♀ 17th March, 1895.

6. PSEUDONYMPHA CASSIUS Godt.

Karkloof, Natal, 4200 feet, 31st January, 1st and 5th February,
1897.

7. PSEUDONYMPHA SABACUS Trim.

Karkloof, 1st, 5th, and 10th February, 1897.

8. NEOCÆNYRA EXTENSA, sp. n. (Plate XX. fig. 1.)

♂. Allied to *N. gregorii*, but differing in the much longer costal margin of the primaries, the reddish-orange irides to the ocelli, the more sharply defined black transverse lines on the under surface, the submarginal lines on the secondaries being also much more regular, the postmedian line much less zigzag in character and approaching nearer to the ocelli, the inner line crossing the cell indistinct, but bordered on abdominal area with ferruginous scales; base of costa also ferruginous. Expanse of wings 50 millimetres.

Salisbury, 5000 feet, Mashonaland, 12th January, 1895.

Incorrectly identified as *N. duplex*, which it does not at all resemble.

NYMPHALINÆ.

9. CHARAXES SATURNUS Butl.

♂. Upper Hanyani River, Mashonaland, 4700 feet, 20th July,
1895.

10. JUNONIA ARCHESIA Cram.

Dry form. Salisbury, 5000 feet, Mashonaland, 19th May, 1895.

10 a. JUNONIA PELASGIS Godt.

Wet form. Gadzima, Umfuli River, 4200 feet, 27th and 30th
December, 1895.

11. JUNONIA SESAMUS Trim.

Salisbury, Mashonaland, 5000 feet, 17th March; Enterprise Camp, Salisbury, 21st June, 1895; Karkloof, Natal, 4200 feet, 20th February, 1897.

12. JUNONIA CALESCENS Butl.

Junonia octavia var. *natalensis* Staudinger (nec *natalica* Felder).
Gadzima, 4200 feet, Umfuli River, Mashonaland, 2nd, 22nd, and 27th December, 1895.

13. JUNONIA TRIMENI Butl.

♀. Marudsi River, Mazoe District, Mashonaland, 1st January, 1895; Gadzima, 4200 feet, Umfuli River, 22nd and 23rd December, 1895.

These were labelled by Mr. Marshall as *J. simia* Willgr., a much smaller and differently shaped insect, with very different pattern on the under surface and no rosy-whitish discal streak above.

A single small example of *J. simia* was obtained at Gadzima on the 30th December.

14. JUNONIA AURORINA Butl.

Karkloof, Natal, 4200 feet, 29th to 31st January, 10th, 11th, and 17th February, 1897.

This is stated by Mr. Marshall to be the wet-season form of *J. tugela*, but from his own dates it is certain that both fly together in February; moreover, judging them by *J. artavia*, they both have a dry-season under surface to the wings: I am therefore naturally very sceptical as to the identity of these two allied species.

15. JUNONIA TUGELA Trim.

Karkloof, Natal, 4200 feet, May 1896, and 20th February, 1897.

16. JUNONIA CUAMA Hewits.

Dry form. Enterprise Camp, near Salisbury, 5000 feet, Mashonaland, 7th July; Gadzima, 5th August.

Wet form. Mazoe District, 4000 feet, 1st November, 1895.

As I have suspected for some time, the seasonal forms of this species differ very little; that of the wet season has the black markings of the upper surface more pronounced, the costa of primaries rather shorter (giving a squarer character to the wing) than in the dry form, the markings below much better marked and the discal spots more decidedly ocelloid. I am now quite satisfied that *J. trimeni* has nothing to do with *J. cuama* or with *J. simia*. It will be remembered that I have always opposed the amalgamation of these three very dissimilar species on the ground that they are undoubtedly on the wing simultaneously at all seasons.

17. JUNONIA ELGIVA Hewits.

Malvern, Natal, 800 feet, 22nd and 30th March, 1897.

18. JUNONIA CLELLA Cramer.

♂♂. Gadzima, 4200 feet, Umfuli River, Mashonaland, 29th August and 2nd December, 1895.

One of the specimens is a curious aberration in which the large blue patch on the secondaries is crossed near its apical outer border by three large more or less oval black spots; just in front of the blue patch is a scar, probably indicating some injury done to the pupa, which apparently has modified the deposition of pigment in the scales.

19. JUNONIA ARTAXIA Hewits.

Gijima, Umfuli River, 29th July; Gadzima, 3rd October, 1895.
Wet form. *J. nachtigali* Dewitz.
Gadzima, 27th and 28th December, 1895.

20. HYPOLIMNAS MISIPPUS Linn.

Gadzima, 22nd, 27th, and 30th December, 1895.

21. HAMANUMIDA DÆDALUS Fabr.

Salisbury, 23rd March and 18th April; Hartley Hills, Umfuli River, 4300 feet, 25th July; Gijima, 24th August; Gadzima, 4200 feet, 26th December, 1895.

The wet-season phase was obtained from December to the end of March, the dry phase from April to the end of August.

22. NEPTIS AGATHA Cram.

Malvern, Natal, 6th and 13th April, 1897.

23. EURYTELA HIARBAS Drury.

Karkloof, Natal, 9th February and 24th March; Malvern, 27th March, 1897.

ACRÆINÆ.

24. ACRÆA LYCIA Fabr.

Malvern, 800 feet, Natal, 13th April, 1897.

25. ACRÆA RAHIRA Boisd.

Marudsi River, Mazoe District, Mashonaland, 1st January; Gadzima, 22nd August, 1895.

26. ACRÆA NOHARA Boisd.

♀, Salisbury, 24th March, 9th June; ♂♀, Enterprise Camp, 4th July, 1895.

The specimens are marked as "wet" and "dry," but I see no great difference between them; they are all rather small examples, and a varietal name is attached to them: if not already published, it were better that it should not be.

27. *ACRÆA DOUBLEDAYI* Guér.

Wet. ♂ ♀, Malvern, near D'Urban, Natal, 800 feet, 2nd to 4th March, 1897.

Dry. ♂, Gadzima, 4200 feet, Umfuli River, Mashonaland, 11th August; Gijima, 23rd August, 1895.

If the single male from Mashonaland represents the normal dry-season phase, it only differs from that of the wet-season in its inferior size, and would be indistinguishable from starved examples obtained during the rains; both, however, differ very considerably from the wet form of the scarcely distinct *A. nero* of Eastern Africa.

28. *ACRÆA ANACREON* Trim.

Dry-season form. Karkloof, 4200 feet, Natal, 20th February, 1897.

An extraordinarily well-developed example showing nearly double the usual expanse of wings.

"*Dry*" and *wet form.* *A. induna*, Trim. Gijima, Mashonaland, 14th August; Gadzima, 18th December, 1895.

The so-called dry form of *A. induna* (because obtained in the dry-season) is a starved and somewhat worn little male, which, in my opinion, is only a belated wet form (provided that the heavy black apex really is seasonal, as it is said to be in certain species in the genus). The black apical patch in this example is slightly reduced, as might be expected; but Mr. Marshall has himself admitted that in some of the species this black patch is a characteristic of the wet season; in any case it is certainly a varietal, not specific, character, inasmuch as we have complete series of intergrades between the extremes in several forms of *Acræa*.

29. *ACRÆA ASEMA* Hewits.

Gadzima, Umfuli River, 29th July, 11th, 14th, and 24th August, 1895.

Mr. Marshall considers this to be the dry form of the following, of which he sends one curious example, said to be the intermediate form; it certainly looks like it, but I should like more conclusive evidence than is afforded by one specimen which was obtained almost at the same time (in the same month) as *A. asema*.

30. *ACRÆA VIOLARUM* Boisd.

"*Intermediate form.*" Hartley Hills, Mashonaland, 27th July, 1895.

31. *ACRÆA CALDARENA* Hewits.

♂ *wet form*, Salisbury, 31st May; ♀ ♀ *dry form*, Gadzima, 4th August and 20th September, 1895.

It would seem that the seasonal forms of this species differ chiefly in size, the dry form being smaller; both phases agree in the large black apical patch, proving that this is not an invariable seasonal character, but by no means proving that it is not so in most of the species which possess it.

32. *ACRÆA PETRÆA* Boisd.

Malvern, 800 feet, Natal, 13th April, 1897.

33. *ACRÆA ANEMOSA* Hewits.

Gadzima, 4200 feet, Umfuli River, Mashonaland, 31st August, 3rd October, 20th December, 1895.

34. *ACRÆA NEOBULE* Doubl.

♂ ♂, Gadzima, 3rd August, 1st December, 1895; ♀ ♀, Malvern, 25th March, 5th April, 1897.

The seasonal forms seem to differ very little.

35. *ACRÆA HORTA* Linn.

♀, Frere, 3800 feet, 24th December, 1896; Estcourt, 4000 feet, 19th January; ♂ ♂, Karkloof, 4200 feet, Natal, 4th and 11th February, 1897.

LYCÆNIDÆ.

36. *ALÆNA NYASSÆ* Hewits.

Gadzima, 24th December, Mazoe, 29th December, 1895.

37. *POLYOMMATUS BÆTICUS* Linn.

Loesskop, 4500 feet, Little Tugela River, Natal, 20th December, 1896.

38. *CATOCHRYSOPS ASOPUS* Hopff.

♀ *dry form*, Gijima, 11th August; *wet form*, Gadzima, 19th November, 1895.

39. *CATOCHRYSOPS BARKERI* Trim.

♀, Malvern, 800 feet, Natal, 11th March, 1897.

40. *CATOCHRYSOPS PATRICIA* Trim.

♂ ♂, Loesskop, 4500 feet, Little Tugela River, Natal, 20th December, 1897; ♀ ♀, Gadzima, Mashonaland, 23rd and 25th December, 1895.

41. *CATOCHRYSOPS PLEBEIA*, sp. n. (Plate XX. fig. 2.)

Lycæna parsimon Trim. (nec auct. vetust.).

As I have already stated, this is certainly not the Fabrician species, which occurs on the N.-western coast of Africa; it differs from the latter and the nearly allied *L. patricia* in the smoky-brown, somewhat thinly-scaled upper surface of the male, with other minor characters indicated in Mr. Trimen's full description.

♂, Mazoe District, 23rd December, 1894; ♀, Salisbury, 12th January, 1895; ♂, Gadzima, 25th December, 1895; ♀, Estcourt, Natal, 30th December, 1896; ♂, 1st January, 1897.

42. *CATOCHRYSOPS GLAUCA* Trim.

♂, Gadzima, 26th December, 1895.

43. *CATOCHRYSOPS ARIADNE*, sp. n. (Plate XX. figs. 3, 4.)

Nearly allied to *C. niobe*, larger; differs above in the narrower deep smoky border to all the wings and the slightly clearer violet ground-colouring. On the under surface all the black and brown spots, which are more numerous, are distinctly edged with pure white; the discal white band immediately following the transverse series of black spots is well defined and pure white in all the wings, whilst in the secondaries it is farther from the outer margin; the submarginal annular markings are much wider, but indistinct on the secondaries; the subanal black spot, however, is considerably larger, encloses a metallic-blue crescent, and is edged internally by a Λ -shaped orange marking: the upper surface of the female is shot with golden cupreous, and towards the base with lilac; otherwise it resembles the male. Expanse of wings 39 millimetres.

Three males and one female, Karkloof, Natal.

This is the species referred to by Mr. Marshall (*vide* Introduction to the present paper) as probably distinct from *C. niobe*. There is, of course, just a possibility that it may prove to be the wet form of *C. niobe*, all our examples of which were obtained in September; but I know of no other *Catochrysops* which exhibits such well-defined seasonal characteristics, whilst the different habits of the two insects are strongly suggestive of specific distinction, though not necessarily conclusive.

44. *CATOCHRYSOPS DOLOROSA* Trim.

Estcourt, 1st and 3rd January, 1897.

45. *CATOCHRYSOPS IGNOTA* Trim.

Frere, 19th December, 1896.

46. *CATOCHRYSOPS MAHALLOKOÆNA* Wallgr.

♀, Estcourt, 17th January, 1897.

This species has the neuration of *Catochrysops*, but more nearly the pattern of *Neolycæna*.

47. *NEOLYCÆNA CISSUS* Godt.

♂♂, Gijima, 17th August; Gadzima, 31st December, 1895.

The dry-season form is much smaller and with all the markings below less prominent.

48. *CUPIDOPSIS JOBATES* Hopff.

Frere, 24th and 26th December, 1896.

49. *AZANUS NATALENSIS* Trim.

Estcourt, 8th January, 1897.

50. *AZANUS MORIQUA* Wallgr.
Estcourt, 15th to 21st January, 1897.
51. *AZANUS JESOUS* Guér.
Gadzima, 6th November, 21st and 24th December, 1895;
Estcourt, 15th, 16th, 18th, 19th, and 20th January, 1897.
52. *AZANUS ZENA* Moore.
Estcourt, 15th to 21st January, 1897.
53. *AZANUS PLINIUS* Fabr.
Salisbury, 9th June, 1895; Estcourt, 19th January, 1897.
54. *NACADUBA SICHELA* Wallgr.
Mazoe District, 24th October, 1894.
55. *ZIZERA ANTANOSSA* Mab.
Salisbury, 9th December, 1894; Malvern, 27th February, 1897.
New to the Museum from South Africa; but specimens, apparently of this species, are in the collection from Sierra Leone and Wadelai.
56. *ZIZERA LUCIDA* Trim.
Karkloof, 11th February; Malvern, 6th and 13th April, 1897.
57. *CASTALIUS HINTZA* Trim.
♂ (as ♀), Malvern, 3rd March, 1897.
58. *LYCÆNESTHES LIODES* Hewits.
♀, Karkloof, 1st February, 1897.
59. *LYCÆNESTHES OTACILIA* Trim.
♂ ♂, ♀, Estcourt, 17th and 19th January, 1897.
60. *LYCÆNESTHES AMARAH* Lef.
Gadzima, 28th December, 1895.
61. *LYCÆNESTHES ADHERBAL* Mab.
Mazoe District, 24th, 25th, and 29th October, 1894.
62. *SCOLITANTIDES BOWKERI* Trim.
Karkloof, 9th February, 1897.
Probably most nearly allied to *S. thespis*, but approaching *Uranothauma* somewhat in the pattern of the under surface; it is quite new to the Museum collection.
63. *HYREUS LINGEUS* Cram.
Gadzima, 17th September, 1895; Karkloof, 29th January, 1897.
64. *ZERITIS AMANGA* Westw.
Gadzima, 2nd October, 1895.

65. ZERITIS HARPAX Fabr.

♂ ♂, Mazoe District, 24th and 25th October; ♀, 17th November, 1894; ♂, Gijima, 11th August, 1895; ♂ ♂, ♀, Estcourt, 14th, 16th, 19th, and 20th January, 1897.

66. CRUDARIA LEROMA Willgr.

Gadzima, 10th and 18th September, 1895.

67. LACHNOCNEMA BIBULUS Fabr.

♀, Estcourt, 16th December, 1896; ♀, 1st January, ♀, 19th January, 1897.

68. LACHNOCNEMA DURBANI Trim.

♀, Estcourt, 30th December, 1896; ♂, 1st January; ♂ ♂, ♀, 3rd January, 1897.

69. THESTOR BASUTA Wallgr.

♂ ♂, Frere, 15th and 19th December, 1896; ♂ ♂, ♀ ♀, Estcourt, 1st, 8th, and 13th January, 1897.

70. ALÆIDES TRIKOSAMA Wallgr.

Frere, 26th December, 1896; Estcourt, 8th, 14th, and 17th January, 1897.

71. ALÆIDES ORTHRUS Trim.

Estcourt, 17th and 19th January, 1897.

72. CHRYSOPHANUS ORUS Cram.

♂ ♀, Frere, 18th December, 1896.

73. TINGRA TROPICALIS Boisd.

Malvern, 17th, 19th, 20th, 22nd, and 30th March, 6th April, 1897.

74. MYRINA FICEDULA Trim.

Malvern, 5th and 6th April, 1897.

75. SPINDASIS CAFFER Trim.

Gadzima, 4th August, 1895.

Dry form, with reduced orange anal patch.

76. SPINDASIS MASILIKAZI Wallgr. (Plate XX. fig. 5.)

Mazoe District, 31st December, 1894; Gadzima, 29th and 31st August, 4th and 5th September, 30th December, 1895.

77. SPINDASIS ELLA Hewits. (Plate XX. fig. 6.)

S. homeyeri, Marshall (*nec* Hewits.).

Distinctly smaller than *S. homeyeri*, the orange markings on the upper surface of the primaries entirely different, consisting normally of a spot in the cell followed by a transverse band

beyond the cell; the former is, however, sometimes carried obliquely downward, so as to unite with the latter (forming a large V-shaped character); the submarginal orange band consists of three portions, a spot near the costa and two transverse irregular bifid (rarely subconfluent) spots below it; the anal orange patch on the secondaries of *S. homeyeri* is replaced by a sordid ashy patch marked with the usual silver spots; the blue areas of *S. homeyeri* are dull greyish lavender in this species. Apart from the pale buffish-brown ground-colour, the under surface of the wings differs entirely from that of *S. homeyeri*: all the markings are edged with brown (not ferruginous or dull red); those of the primaries are emphasized on the costal margin by a series of about eight jet-black spots, they consist of three fairly regular equidistant oblique bands between the base and the end of the discoidal cell, then follows a costal spot followed by an irregular transverse discal band dislocated at second median branch, this again is followed by a more or less defined, partly linear and partly normal band from costa to submedian vein and a very indistinct dusky submarginal line; marginal line jet-black, internal area and fringe white somewhat pearly: the markings of the secondaries consist of two series of three spots towards the base parallel to the abdominal border, an irregular armillate band, acutely elbowed below the first median branch and interrupted on submedian vein, a short somewhat irregular discal band from costa to third median branch, and an unevenly zigzag submarginal band with indistinct outer edging; marginal line black from anal angle to third median branch; all these bands, as usual, have silvery centres; fringe white, excepting at anal angle, where it is black, the spot above it being narrowly black, then dull chocolate, followed by a sprinkling of black scales; the second spot on the other side of the submedian vein is externally of the ground-colour, internally silver followed by a sprinkling of black scales. Expanse of wings 29 millimetres.

Gadzima, Mashonaland, 31st August, 13th and 25th September, 1895.

As Trimen compares this species with his "*S. natalensis*" = *S. caffer* (to which, in my opinion, it has but little affinity), a description of its peculiarities compared with *S. homeyeri* will, I think, be useful to future workers. Hewitson's type is a very poor and damaged male, in which none of the orange bands on the upper surface are united; the union of the two inner bands in one of Mr. Marshall's specimens shows that this species is not nearly related to any of the other described forms in the genus. In the *S. natalensis* group the cell-spot even when elongated into a band does not join the postmedian band, whereas the latter frequently joins the discal band. In *S. ella* the postmedian and discal bands, being perfectly parallel, never could unite.

78. *VIRACHOLA ANTALUS* Hopff.

♀, Mazoe District, 26th October 1894.

79. *IOLAUS CÆCULUS* Hopff.

♂, Gijima, 18th August; ♂ ♀, Gadzima, 18th October and 23rd December, 1895.

80. *ARGIOLAUS TRIMENI* Wallgr.

Marudsi River, Mazoe District, 21st December, 1894; Gadzima, 17th September, 1895.

PAPILIONIDÆ.

PIERINÆ.

81. *MYLOTHRIS RÜPPELLII* Koch.

♂, Enterprise Camp near Salisbury, 30th June, 1895.

The males of this species seem to be either very local or rare, as we previously had only one example received from the Godman and Salvin Collection.

82. *NYCHITONA MEDUSA* var. *ALCESTA* Cram.

Malvern, 31st March, 1897.

83. *COLIAS HYALE* var. *ELECTRA* Linn.

♂, Frere, 24th December, 1896.

84. *TERIAS BRIGITTA* Cram.

Wet form. ♂, Marudsi River, 31st December, 1894; Salisbury, 16th March, 1895; ♂ ♀, Frere, 24th and 26th December, 1896; ♀, Estcourt, 30th December, 1896; ♂, Malvern, 31st February, 1897.

Dry form. ♀ ♀, Enterprise Camp near Salisbury, 23rd June, 1895; Gadzima, 1st September, 1895.

One of the females taken in June was labelled as a male, but the true dry-season male appears to be excessively rare.

85. *TERIAS MARSHALLI* Butl.

Wet form. ♂ ♀, Karkloof, 5th and 13th February, 1897.

86. *TERIAS HAPALE* Mab. var. *ÆTHIOPICA* Trim.

Dry form. Mazoe District, 23rd October, 1894; Enterprise Camp near Salisbury, 23rd June and 4th July; Gijima, 14th August, 1895.

I was amused to find some of the specimens labelled *T. æthiopica* and others *T. orientis*, others again altered from one to the other. As a matter of fact, *T. orientis* is the intermediate seasonal form of *T. senegalensis*, and identical with *T. butleri*; possibly Mr. Marshall might now consider the whole as one very variable species.

87. *TERIAS SENEGALENSIS* Boisd.

Wet form (as *T. butleri*). Salisbury, 12th January, 20th March, 5th May; Gadzima, 21st December, 1895.

88. TERACOLUS ACHINE var. SIMPLEX Butl.

♂ ♀, Gijima, 8th and 18th August, 1895.

The female now sent is the first authentic example of this dry-season form of *T. achine* which I have seen; it is interesting as vaguely resembling the female of the northerly *T. isaura*.

Race *T. TRIMENI* Butl.

♂ ♂ (as *T. antevippe*), dry form, Upper Hanyani River, Mashonaland, 20th July, 1895.

89. TERACOLUS GAVISA Wallgr.

♂ ♂, Estcourt, 30th December, 1896; 3rd and 24th January, 1897.

These are all typical wet-season examples.

90. TERACOLUS EXOLE ♂ Reiche.

Malvern, 8th March, 1897.

The wet form of the male.

91. TERACOLUS ANNÆ Wallgr.

Hartley Hills, Mashonaland, 24th, 26th, and 27th July, 1895.

The specimens belong to the dry form (*T. wallengrenii*), the female somewhat approaching that sex of the fulvous-tipped variation of the closely allied *T. callidia* (= *hildebrandti*).

92. CATOPSILIA FLORELLA Fabr.

♀ ♀, Salisbury, 21st and 25th April, 1895; ♂ ♂, Karkloof and Malvern, 19th February and 7th March, 1897.

93. PINACOPTERYX PIGEIA Boisd.

Malvern, 13th April, 1897.

94. LEUCERONIA ARGIA Fabr.

♀, Karkloof, May 1896; ♂ ♂, February 1st to 11th, 1897.

All the Natal females sent us by Mr. Marshall are far more lightly marked on the upper surface than the more Northern, Eastern, and Western varieties, and all have the base of the primaries orange-vermilion above.

PAPILIONINÆ.

95. PAPILIO CORINNEUS Bert.

Gadzima, 25th September, 1895.

96. PAPILIO BRASIDAS Feld.

Malvern, 27th March and 10th April, 1897.

I have always believed this to be the *P. anthemenes* of Wallengren, but I see that Trimen identifies the latter with *P. corinneus*.

97. *PAPILIO OPHIDICEPHALUS* Oberth.

Karkloof, 1st and 4th February, 1897.

98. *PAPILIO EUPHRANOR* Trim.

Karkloof, 5th February, 1897.

99. *PAPILIO NIREUS* Linn.

Karkloof, 9th and 13th February, 1897.

HESPERIIDÆ.

100. *EAGRIS JAMESONI* E. M. Sharpe. (Plate XX. fig. 7.)

Dry form, Gijima, 18th and 19th August; *wet form*, Gadzima, 22nd December, 1895¹.

101. *SAPÆA TRIMENTI* Butl.

Gadzima, 25th September, 1895.

102. *SAPÆA PARADISEA* Butl.

Mazoe District, 29th December, 1894; Gadzima, 5th September, 1895.

103. *ABANTIS VENOSA* Trim.

Gijima, 18th August; Gadzima, 4th September, 1895.

This is new to the Museum collection.

104. *CAPRONA CANOPUS* Trim.

Karkloof, 9th February, 1897.

105. *PYRGUS SPIO* Linn.

Loesskop, 4500 feet, Little Tugela River, 20th December, 1896; Estcourt, 1st January, 1897.

The first of these examples was labelled as "*Hesperia mafa*," and the following was queried as *H. mafa*; the two forms, if distinct, are very closely allied.

106. *PYRGUS MAFA* Trim.

Loesskop, 4500 feet, Little Tugela River, 20th December, 1896.

107. *OXYPALPUS RUSO* Mab.

Mazoe District, 27th October, 1894; Enterprise Camp, near Salisbury, 2nd July; Gadzima, 17th August and 19th September, 1895.

These were labelled as *O. harona* Westw., but we possess every link to typical *O. ruso* Mab.; the species is a very variable one, as I suspect the following also is.

¹ The wet form has the ground-colour of the wings smoky brown instead of golden brown and ochraceous (see figure).

108. PAROSMODES ICTERIA Mab.

Enterprise Camp, near Salisbury, 7th July, 1895.

I have always believed this species to be the *P. ranoha* of Westwood (now considered synonymous with *P. morantii*, Trimen). The figure of the latter differs from it about as much as do the extreme variations of the preceding species.

109. PAROSMODES MORANTII Trim.

Gadzima, 19th September, 1895.

New to the Museum series. I should not be at all surprised to see intergrades between this species and *P. icteria*: the position of the orange band on the secondaries varies a good deal in our series of the latter species; but the coloration and pattern of the under surface, although very variable, still show sufficient differences to warrant the separation of the two butterflies for the present.

110. CYCLOPIDES METIS Linn.

Karkloof, 27th January, 8th and 11th February, 1897.

111. KEDESTES MACOMO Trim.

Malvern, 13th April, 1897.

112. KEDESTES TUCUSA Trim.

Estcourt, ♂ ♀ 13th, ♂ 14th January, 1897.

113. KEDESTES WALLENGRENII Trim.

Frere, 24th December, 1896.

114. KEDESTES NIVEOSTRIGA Trim.

Karkloof, 29th and 31st January, 11th February, 1897.

115. GEGENES LETTERSTEDTI Wallgr.

Estcourt, 1st January, 1897.

This is *G. hottentota* of authors other than Latreille, the latter being (as previously stated) the *G. obumbrata* of Trimen.

116. GEGENES HOTTENTOTA Latr.

♂, Salisbury, 10th March; ♀, 6th April, 1895; ♀, Estcourt, 3rd January, 1897.

The female of this species is new to the Museum collection. It seems hardly conceivable that a species the male of which has a large brand on the primaries can be a dimorphic form of one without a trace of a brand, but (as Dr. Holland observes) "the females are absolutely indistinguishable."

117. BAORIS AYRESII Trim.

Gadzima, 10th September, 1895.

New to the general series of the Museum collection, though represented by one example in the Hewitson series.



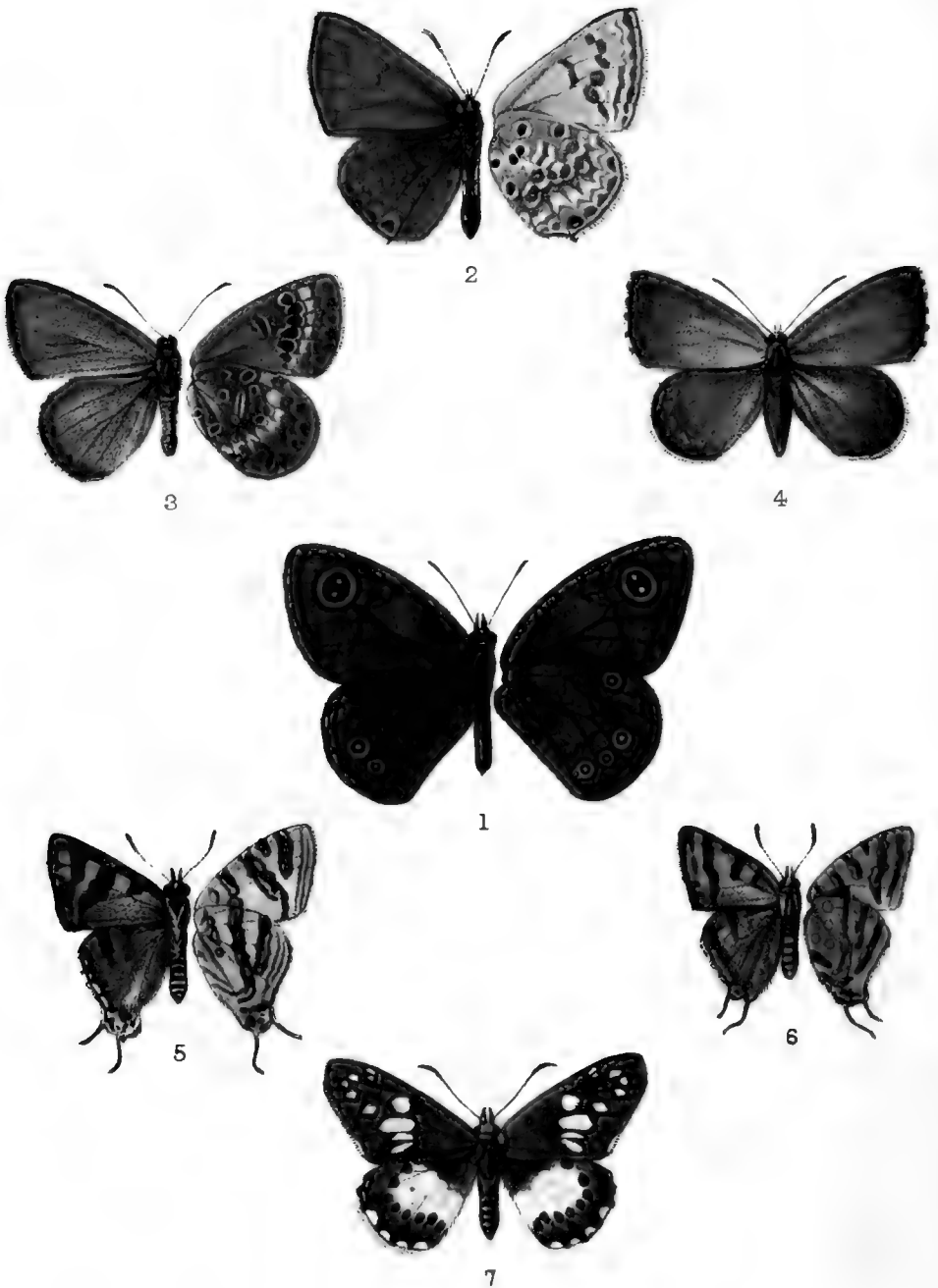

E. C. Knight del. et lith.

West, Newman chromo

Butterflies from Natal.

118. PARNARA DETECTA Trim.

Mazoe District, 4th January, 1895.

119. BARACUS INORNATUS Trim.

Karkloof, 30th January and 8th February, 1897.

EXPLANATION OF PLATE XX.

- Fig. 1. *Neocanyra extensa*, ♂, p. 188.
2. *Catochrysops plebeia*, ♂, p. 192.
3, 4. *Catochrysops ariadne*, ♂ ♀, p. 193.
5. *Spindasis masilikazi*, ♂, p. 195.
6. *Spindasis ella*, ♂, var., p. 195.
7. *Eagris jamesoni*, ♂ (wet form), p. 199.

March 15, 1898.

Dr. ALBERT GÜNTHER, F.R.S., V.P., in the Chair.

The Secretary read the following report on the additions to the Society's Menagerie during the month of February 1898 :—

The registered additions to the Society's Menagerie during the month of February 1898 were 61 in number. Of these 12 were acquired by presentation, 14 by purchase, 3 were born in the Gardens, 11 were received by exchange, and 21 on deposit. The total number of departures during the same period, by death and removals, was 107.

The Secretary exhibited some photographs of the Beaver-pond at Leonardslea, Horsham, and read the following notes from Sir Edmund Loder, Bart., F.Z.S., on the subject :—

" I sent particulars of my Beavers to Mr. C. J. Cornish, who has written articles about the Beavers in 'Country Life' and in his new book 'Nights with an old Gunner' ".

" About eight years ago I imported four Beavers from America, and turned them into an enclosure at the bottom of a valley with a small stream running through it. There was at that time a good deal of brushwood and some larger trees, but all these were very soon cut down except a few which I protected with iron.

" It is difficult to know how many young ones were born. One certainly grew up and another was found dead, killed by the others.

¹ 'Nights with an old Gunner and other Studies of Wild Life.' By C. J. Cornish. London, 1897, p. 294.

“The old male must have died after 3 or 4 years. I have bought at different times two or three more Beavers, but I believe these were all killed after a few weeks by two old (probably barren) females. These, therefore, I caught up, and having secured a young male the colony seemed to flourish again. A young one was seen two years ago, but a few months since a young male was found dead, which was probably the same animal. It had most likely been killed in a fight with its father. It is difficult to say how many Beavers there are now, but only three have been seen together lately at any one time.

“The earlier dam was built of small sticks and earth; now the Beavers use much larger sticks, and I think they are doing much more work than ever.

“About 18 months ago I enlarged the enclosure, taking in ground lower down with more of the stream. The Beavers at once set about building a new dam, and bayed up the water back to the old dam, partly submerging it. The object of the dam is to make sure of a pond sufficiently deep to keep it from freezing to the bottom in hard winters. When the water is frozen over the Beavers depend for their living on their winter store of twigs and branches, which they fix in the mud at the bottom of their pond. The mouths of their burrows being under water, they cannot come out when the ice covers the water.

“The growth of the ‘lodge’ is curious. It can hardly be said that Beavers *build* a lodge, it grows. They begin by making a burrow in the bank, opening under water and rising up into dry land. At the end is a chamber: this they floor with long strips of white wood, which look at first sight like clean straw. As this gets wet and muddy from their feet they put down fresh straw for bedding, and so the floor of the chamber rises. To get head room they scratch away the earth from the ‘ceiling’ until at last they get through into open air. This hole they stop up from the outside, heaping upon the chamber sticks and mud and turf. The process goes on until quite a high lodge is built.”

Mr. R. E. Holding exhibited and made remarks upon a fine pair of horns of the “Sunga” or Galla Ox of Abyssinia, indicating briefly their upright growth and some minor points in the form of the frontal bones and horn-cores, which showed their affinity to the Humped Cattle or Zebus of India, this interesting group also extending into Egypt, Abyssinia, and East Africa down to the Cape. In the Galla country these cattle were said to attain a large size, and to be usually of a bay or brown colour, and to carry enormous horns. A pair in the Royal College of Surgeons Museum were 46 inches long each, and 15 inches in girth at the base. Another pair in the British Museum were 41½ inches long each horn, and 15 inches in girth at the base. Other examples even larger were known. The pair exhibited were slightly under these sizes. The

origin of this curious and interesting humped variety of Cattle seemed doubtful, but that they were well-known to the ancient



Horns of Galla Ox.

Egyptians is attested by numerous careful drawings on the decorative wall-paintings and monuments of that period.

A communication from Dr. G. Stewardson Brady, F.R.S., "On new or imperfectly-known species of Ostracoda, chiefly from New Zealand," was read. It contained descriptions of the Ostracoda collected in New Zealand by Mr. H. Suter, for the Zoological Museum of Copenhagen, and by Mr. G. M. Thomson, of Dunedin. It also included a description of an Ostracod from the Bay of Bengal, presenting some remarkable peculiarities of the mouth-organs, and

constituting the type of a new genus, which was proposed to be called *Eupathistonia*. Of the New Zealand species treated of 16 were described as new, and the new generic term *Trachyleberis* was proposed for the reception of *Cythere scabrocuneata*, Brady.

This paper will be published in full in the 'Transactions.'

The following papers were read :—

1. On the Early Post-larval Stages of the Common Crab (*Cancer pagurus*), and on the Affinity of that Species with *Atelecyclus heterodon*. By J. T. CUNNINGHAM, M.A.¹

[Received February 15, 1898.]

(Plate XXI.)

A complete account of the natural history of the common Edible Crab is not in existence, and the naturalist who endeavours to construct a life-history of the species from the separate observations recorded in zoological literature will find that direct observations on this particular species are very scarce. A general knowledge of the development of *Brachyura* has been obtained from the partial study of various species, but the systematic investigation of the diagnostic characters of the larval and immature stages in the various divisions of the suborder has yet much to accomplish. With regard to this species neither the Zoæa, nor the Megalopa, nor the earliest post-larval form has yet been figured and described in sufficient detail.

The paper by R. Q. Couch in the Report of the Falmouth Polytechnic Society for 1843 contains a brief description of the Zoæa of this species, with a figure in the illustrating plate. A special paper on the development of the Edible Crab was published by the same author in the Reports of the Penzance Natural History Society for 1853-4-5. This paper is based on observations made in 1852. The Zoæa is here again mentioned, and reference is made to a figure of it as plate i. fig. 1; but I have been unable to find any plate or figure in the volume. The Megalopa and the earliest post-larval stage are also described, but as it is not my intention in the present paper to consider the larval stages, I need only refer to the description of the first post-larval stage, into which the Megalopa changes after ecdysis. It is stated that in this stage the margin of the carapace was much more waved than in the Megalopa; the animal was now unlike any previous state, but not at all like the adult. The lateral rim was indented as in the adult, but instead of the oval form it was almost quadrangular; the sides, instead of being rounded off as in the adult, were perpendicular.

Prof. S. I. Smith, in 'The Invertebrate Fauna of Vineyard Sound,'

¹ Communicated by F. E. BEDDARD, F.R.S.

U.S. Fish. Comm. Rep. 1871-72, published in 1873, gives some observations on the early stages of the American species *Cancer irroratus*. He states that Zoæas of the species were taken abundantly in Vineyard Sound from June 23rd till late in August. Megalopas were also taken, and that the change of the Megalopa into the first crab-form was observed in aquaria. In this early stage the young Crab was quite different from the adult. The carapace was about 3 mm. long and slightly less in breadth. The front was much more prominent than in the adult. The antero-lateral margin was much more longitudinal than in the adult, and was armed with 5 normal teeth, which were long and acute, and 4 much smaller secondary teeth alternating with these. Young Crabs in this stage were once or twice taken in the tow-net. Figures of the Zoæa and Megalopa are given, but none of the first crab-form. The most important part of this description in relation to my own observations is that concerning the teeth on the antero-lateral margin.

During last summer, while engaged in presenting to Cornish crab-fishermen the known facts concerning the natural history of the animals it is their business to capture, I endeavoured, when leisure and opportunity allowed, to trace the successive stages of the Edible Crab in the littoral waters. Having failed to identify any of the stages in the produce of the tow-net, or to obtain any stages later than the Zoæa hatched directly from the ovum, I began to search the shore at low tide in the hope of finding the earliest ambulatory stages derived from the swimming larvæ hatched some weeks earlier. This search was also for a time unsuccessful, but at the Laboratory of the Marine Biological Association at Plymouth I obtained on Sept. 28th the specimens which form the subject of the present paper. They were found among a quantity of coralline growth collected on the shore at Wembury Bay and were examined in the Laboratory, and my possession of them is due entirely to the exertions made by the Director and his assistants on my behalf.

The specimens were ten in number, the smallest 2.5 mm. across the carapace, the largest 7 mm. The largest specimen was quite similar to the adult *Cancer pagurus*. Two or three of the smallest specimens had the characters shown in fig. 1 (Plate XXI.), while the rest were in a condition intermediate between this and the ordinary condition of *Cancer pagurus*. One of the most typical of these intermediate conditions is shown in fig. 2 (Plate XXI.), drawn from a specimen 4 mm. in breadth of carapace.

For a time it seemed doubtful whether the smallest specimens as represented in fig. 1 were the young of *Cancer pagurus* or of *Atelecyclus heterodon*, as the antero-lateral teeth of the carapace are so similar to those in the adult condition of the latter species. The specimens seemed, however, to belong to the same series, and the facts that the outline of the carapace is not so regularly circular in the smallest specimens as in *Atelecyclus*, and that no more advanced specimens of that species were found in the

collection, seem to exclude the possibility that any of the specimens belong to that species. Further, as we have seen, the characters of these small specimens agree with the brief description given by S. I. Smith of the earliest ambulatory form of an American species of *Cancer*.

A minute examination of the specimen represented in fig. 1 reveals the following peculiarities:—The anterior portion of the carapace between the eyes is much more prominent than in the adult *Cancer*. It consists, as in the latter, of five principal projections or teeth, each of which carries secondary pointed teeth of different sizes. The eyes are much larger in proportion than in the adult, and on the anterior border of each eye-stalk is a tooth. The margin of the orbit carries minute teeth. The antero-lateral margin of the carapace bears altogether 10 teeth, five larger and 5 smaller alternating with each other. As seen in the quotation given above, Prof. S. I. Smith states that the number of teeth in the first crab-form of *Cancer irroratus* is only 9, 5 “normal,” and 4 smaller alternating with them; but it seems to me probable that he omitted to notice the last small tooth behind the fifth large tooth. In any case this tooth is undoubtedly present in my specimens, and, as I shall show, its presence is of some importance. The larger teeth and some of the smaller exhibit secondary teeth on their hinder margins, and on these margins there are also some setæ. From the tenth tooth there extends backward a granulated ridge corresponding to a similar ridge in the adult *Cancer*.

The antennæ are relatively longer than in the adult. The ambulatory legs or pereopods are similar in shape to those of the adult, but the anterior pair or chelipeds differ in the possession of rows of pointed tubercles on the carpus and propodus, and a few smaller tubercles are visible also on the dactylus. On all the pereopods and on the antennæ there are a considerable number of setæ.

The length of the carapace in these smallest specimens is about 3 mm.; the breadth is only 2.5 mm. We may conclude therefore, both from size and characters as compared with those given by S. I. Smith in reference to *Cancer irroratus*, that these specimens are in the first crab-stage, and are derived directly from the Megalopa stage. The length of the carapace in this stage is thus somewhat greater than the breadth, while in the adult it is much less; even in the largest specimen in the collection here considered the breadth of the carapace is 7 mm., while the length is only 5 mm.

The intermediate stage seen in fig. 2 shows how the transition to the adult form is effected. This stage is probably derived directly from the former by a single ecdysis. In it the carapace is 4 mm. in breadth and slightly less in length. The anterior or rostral portion of the carapace now projects less, and the teeth both here and on the antero-lateral margin have become broader and rounder, while the secondary teeth on their margins have become regular rounded crenations. In this condition the antero-

lateral teeth approach to the form of the quadrate lobes in the same position in the adult, the notches between them in the earlier stage having been filled up by their increase in breadth. In the adult the crenated margin becomes much smoother, the crenations becoming so minute as to be all but obsolete. The tubercles on the outer surface of the chelipeds are in the second stage relatively smaller, but still distinct, and their arrangement in longitudinal rows is more evident. In both stages there are numerous small scattered tubercles on the surface of the carapace, more prominent in the first stage than in the second; in the adult these are reduced to minute granulations.

It is quite obvious that the second stage, represented in fig. 2, could not possibly belong to *Atelecyclus*, or indeed to any other species than *Cancer pagurus*, and I think there is no doubt that this form is derived from the first stage shown in fig. 1. But the evident similarity of the form shown in fig. 1 to *Atelecyclus* at once suggests that the two genera are closely allied, and I was led by this resemblance to compare the two British species more carefully. As a result of this study I have come to the conclusion that *Atelecyclus* properly belongs to the family Cancridæ, and should be placed in close proximity to the genus *Cancer*, not in the place hitherto assigned to it, in the family Corystidæ.

The points of resemblance between *Atelecyclus heterodon* and *Cancer pagurus* are numerous and obvious. In both the anterior margin of the carapace is quinque-dentate, one of the teeth being median, and the two external forming the inner boundaries of the orbits. The antero-lateral teeth require a detailed examination. I have had for this purpose three specimens of *Atelecyclus*, two males 3.7 cm. in diameter, one female 2.4 cm. I find there are really 10 of these teeth in all, as in *Cancer pagurus*. The last or 10th, counting that which forms the outer boundary of the orbit as the first, is at the anterior extremity of the granulated ridge which borders the dorsal surface of the carapace posteriorly. This tooth is sometimes defined behind by a distinct indentation as well as in front. This is the case on both sides of one of the males, on the right side only in the other; in the female the indentation is not very distinct on either side. In *Cancer pagurus* the tenth lateral lobe or tooth, although much less marked than the rest and situated on the postero-lateral margin, is defined posteriorly by a distinct indentation.

In *Atelecyclus heterodon* the 1st, 3rd, 5th, 7th, and 9th teeth are larger, the rest smaller. In my two male specimens the 2nd and 4th teeth are very small, almost rudimentary. Montagu, who first defined the species, called it *septemdentatus*, and Stebbing ('Crustacea,' Internal. Sci. Ser. 1893) states that there are 9 teeth on the antero-lateral margin, and suggests that Montagu did not include the point at each extremity of the series. It seems to me more probable that Montagu omitted the 2nd and 4th on account of their slight development, and also the 10th tooth, which might be regarded as the extremity of the posterior granulated ridge.

In reckoning 9 teeth on the antero-lateral margin, Stebbing follows Thomas Bell ('British Crustacea,' 1853), and, I believe, all other writers who have described the species. Whether the 10th tooth should be counted or not may be considered a matter of opinion if the description of the species is considered apart from its relations to other species; but my own observation has convinced me that the teeth correspond exactly to the broad teeth or lobes of *Cancer pagurus*, and in both species there is a 10th tooth at the posterior end of the series. Thomas Bell noticed this 10th tooth in *Cancer pagurus*, giving as one of the specific characters "latero-anterior margin ten-lobed;" and when, as in his work, only 9 teeth are attributed to *Atelecyclus* the homology of the teeth in the two species is obscured.

It is stated as a peculiarity of the legion Crystinea, containing the single family Crystidæ, that the third pair of maxillipeds do not usually make a complete closure of the mouth-cavity, and are extended over the anterior margin of its frame. But it is mentioned as an exception that in *Atelecyclus* the third maxillipeds do make a complete closure of the mouth-cavity. The real significance of this exception is that in *Atelecyclus* as in *Cancer* the inner edges of the third maxillipeds meet in the middle line.

The form and proportional size of the chelipeds, and of the other legs, are very similar in *Atelecyclus* and in *Cancer*. In *Atelecyclus* there are 7 longitudinal rows of tubercles on the propodus of the chelipeds. In the adult *Cancer* there are no prominent tubercles, but it is easy to verify the fact that the five lower rows are represented by granulated ridges, while the upper two are obsolete. On the preceding segment, or carpus, in *Atelecyclus* there are 4 rows of tubercles, of which the uppermost bifurcates anteriorly. These are likewise represented in *Cancer* by ridges, but the bifurcation of the uppermost is not visible. In the young stages of *Cancer pagurus* which I have figured and described in this paper the rows of tubercles on both the segments mentioned are very similar to those in the adult *Atelecyclus*.

In all the points mentioned in which *Atelecyclus heterodon* approaches to *Cancer pagurus* it differs from *Corystes cassivelaunus*. The form of the carapace in the latter is quite different; it is much longer than broad, and its sides are almost straight and parallel to the antero-posterior axis. There is no median tooth to the rostrum, the extremity of which forms two divergent teeth, and the sides of which slope outward to the orbits without any projecting tooth, but with only a slight rounded prominence at the inner boundary of each orbit. Instead of 10 teeth on the antero-lateral margin, there are 4 widely-separated lateral teeth, with a blunt projection between the 2nd and 3rd. The maxillipeds of the 3rd pair are long and narrow, and their inner edges do not meet in the middle line.

The chelipeds of *Corystes*, instead of being short and robust as in *Atelecyclus* and *Cancer*, are, especially in the male, long, and slender, with long segments, and the rows of tubercles mentioned above

are not represented. In *Corystes* also the tail extends forward only to the sternum of the 3rd pereopods, while in *Cancer* and *Atelecyclus* it extends to the sternum belonging to the chelipeds.

I think it will be agreed that the evidence I have detailed is abundantly sufficient to prove that *Atelecyclus* has no claim to a position in the family Corystidæ and that its proper position is in the Cancridæ next to *Cancer*. The resemblances of the adults are enough to establish this proposition, while at the same time it is confirmed by the greater resemblances between the young *Cancer* and the adult *Atelecyclus*. The peculiarities of the 1st crab-form of *Cancer* thus indicate that the latter in its evolution has diverged from an ancestral form closely similar to *Atelecyclus*, and that in the adult condition of *Cancer* several features which *Atelecyclus* retains throughout life have been considerably modified.

Mr. Walter Garstang (Journ. Mar. Biol. Assoc. vol. iv. no. 3) has recently described the respiratory adaptations in *Corystes cassivelaunus*, in which the antennæ form a tube conveying an anterior afferent current of water to the branchial cavities, and remarks that a similar reversal of the respiratory current occurs in the allied form *Atelecyclus heterodon*. Now, in accordance with this remark, I find that there is a certain degree of similarity between the arrangement of the antennæ and parts surrounding the anterior apertures of the respiratory cavities in the two forms. The antennæ in *Atelecyclus* are not more than one-third the length of those of *Corystes*, but they are provided each with a dorsal and ventral fringe of hairs which by their apposition would form a tube as in *Corystes*. The anterior edges of the external maxillipeds (2nd segment) are also fringed with long hairs which form a ventral floor to the water-channel as in *Corystes*. But the second joint of the peduncle of the antennæ is not flexed on the first in *Atelecyclus* as it is in *Corystes*. The first joint of the antenna is fixed in *Atelecyclus* while it is movable in *Corystes*, and in the former there is a thick fringe of long hairs, extending across the base of the second joint or segment of the external maxillipeds and along the ventral surface of the carapace, which is entirely wanting in *Corystes*. It is evident therefore that the differences, even in the parts here considered, between the two forms are greater than the resemblances, and all that can be said is that there is a slight adaptive similarity in the two cases. In other words, we find in *Atelecyclus* a slight development of a structural adaptation for respiratory purposes, which is much more complete in *Corystes*. The condition of the parts in question in *Atelecyclus* is not such as to indicate any close affinity between the two genera.

DESCRIPTION OF PLATE XXI.

Fig. 1. Early crab-form of *Cancer pagurus*, the Edible Crab. Actual size of specimen 2.5 mm. across carapace. Drawn with Zeiss oc. 3, obj. a_3 , without camera lucida.

2. Transition stage of *Cancer pagurus*; from a specimen 4 mm. across carapace. Drawn under the same conditions as fig. 1.

2. On some Mammals obtained by the late Mr. Henry Durnford in Chubut, E. Patagonia. By OLDFIELD THOMAS.

[Received March 9, 1898.]

In the summer (southern) of 1877-8 Mr. Henry Durnford, whose name was at that time well known as a collector of Argentine mammals and birds, made a trip to Chubut¹ and obtained a certain number of mammals there. The specimens were deposited at the Zoological Society's Office, but were never worked out, and have been lying there ever since. They have now been transferred to the British Museum, and Mr. Sclater has asked me to contribute a list of them to the 'Proceedings.'

None of the species represented in the collection are new, but the record of their locality and Mr. Durnford's short notes on their habits may be of service.

1. *ELIGMODONTIA GRISEOFLAVA* Waterh.

a, b. Feb. 12 and Apr. 3, 1878.

I have long realized that the animal commonly known as "*Phyllotis*" *griseoflavus* has so different a skull from that of the typical species of *Phyllotis*, that it could not be considered as really congeneric with them. But, on the other hand, its cranial characters are by no means so different from those of the long-tailed species of *Eligmodontia*; and rather than make a new generic term for it I refer it to that genus, in which it bears to the other species about the same relative proportion in size as *Mus rattus* does to *M. musculus*.

"This Rat is only found close to the Colony in the summer, but at that season it overruns many of the houses and is extremely destructive, eating boots, calico, &c., and is especially fond of gnawing the metal spouts of teapots. What becomes of it in the winter I do not know, but I believe it lies dormant under the scrub and brushwood. It never burrows in the ground, but lives under old logs, bushes, &c., and the female makes a nest, generally in the centre of a thick bush of bark stripped into fine shreds and any soft material it can find. It can jump and climb with great agility."—*H. D.*

2. *ELIGMODONTIA ELEGANS* Waterh.

a, b. Mar. 3 & 5, 1878.

"Not uncommon among bushes, into which it climbs readily. Comes out in the evening to feed. I do not think this species makes holes in the ground."—*H. D.*

"Like the long-tailed Rat this species is most numerous in the summer, though during the winter a few may be found. It does not enter the house like its large relative, but is extremely

¹ See Mr. Durnford's article, 'Ibis,' 1878, p. 389, for an account of the localities visited.

numerous in the thick scrub and brushwood in the neighbourhood of the Colony, and universally distributed. It makes a small oval nest of fine grass and any soft material, which it places in the centre of a thick bush. It never burrows in the ground, but is extremely numerous among the thorn-bushes."—*H. D.*

3. *ELIGMODONTIA GRACILIPES* Waterh.

a, b. Ad. ♀ and yg., Mar. 18, 1878.

This Mouse is probably the same as the little species from La Plata which I have hitherto identified with Azara's "Laucha," but owing to the nearness of Chubut to the type-locality of *E. gracilipes*, Bahia Blanca, I provisionally use Waterhouse's name as most certainly pertinent. The species differs from most other S. American Muridæ in its larger number of mammæ, possessing from 5 to 7 on each side of the belly, placed equidistant from each other, and not definitely separable into pectoral and inguinal series. Provisionally also I use the generic name *Eligmodontia* not only for the long-tailed species, such as *E. griseoflava*, *elegans*, and *moreni*, but also for the short-tailed *E. gracilipes* and *E. bimaculata*, to which Rengger's "*Mus callosus*" and my "*Oryzomys (?) venustus*" may ultimately prove to be allied. Further examples of all these doubtful forms are very much wanted.

"Not so common as the other species; makes a nest in a thick bush about a foot above the ground. The nest is made of grass torn into fine fragments."—*H. D.*

4. *AKODON CANESCENS* Waterh.

a, b. Dec. 1877 and Apr. 1, 1878.

I am not quite satisfied that this Mouse ought to be distinguished from the common *A. arenicola* of S. Uruguay and Buenos Ayres, although there is a certain amount of difference in colour between the two. The type of *A. canescens* came from Port Desire, Patagonia; that of *A. arenicola* from Maldonado.

"Common in straw-heaps and in granaries."—*H. D.*

"Unlike the long-tailed Mouse this animal burrows in the ground, or more usually takes possession of some of the numerous cracks which may be always found in the earth, and appropriates them for its home. It has five or six young at a birth. It is pretty common, but not so numerous as the long-tailed Mouse."—*H. D.*

5. *OTENOMYS MAGELLANICUS* Benn. (?).

a. Very young. Tombo Point, Jan. 3, 1878.

"I know nothing of this species. I took it near Tombo Point, almost 60 miles to the south of the Colony, and it is the only specimen of this species I have seen. I found it close to the sea-shore."—*H. D.*

6. *CAVIA AUSTRALIS* Geoffr.

a, b. Ad. and yg. Mar. 14 & 18, 1878.

The external resemblance of this Cavy to the skin of *C. boliviensis*

from Bahia Blanca, referred to in my account of Prof. Spegazzini's mammals¹, is very remarkable, widely different as are the skulls of the two forms. Indeed, by the skin alone it would be almost impossible to distinguish them.

"Extremely abundant, and found in every clump of brushwood throughout the neighbourhood. This little animal is very good eating. It feeds on grass, and sits up like a rabbit on its hind-quarters while chewing the mouthful it has just taken."—*H. D.*

7. HIPPOCAMELUS BISULCUS (Mol.).

a, b. Skulls with horns.

These specimens are not labelled, but are presumably from Mr. Durnford's Chubut collection.

The information on which this name is adopted is obtained from Mr. Lydekker's work on the Deer², but I am unable to admit the validity of the reasons which have induced him to reject the name *Hippocamelus* in favour of *Xenelaphus*.

3. Additions to the Knowledge of the Phytophagous Coleoptera of Africa.—Part I. By MARTIN JACOBY, F.E.S.

[Received February 28, 1898.]

(Plate XXII.)

Since my last paper in the Proceedings of this Society was read (see P. Z. S. 1897, p. 527), a good deal of additional material from Mashonaland and West Africa has come to hand, and more may be looked for through the exertions of Mr. Guy Marshall in Mashonaland, so that there is good reason to hope that ere long we shall be well acquainted with the Coleopterous fauna of that region.

The present paper deals with the earlier groups of Phytophaga; the *Halticinae* and *Galerucinae* will form the subject of the second part.

LEMA REGIMBARTI Gestro.

Dark æneous; thorax tuberculate anteriorly, strongly and closely transversely rugose or plicate; elytra dark fulvous, very regularly punctate-striate, the punctures partly elongate, the interstices finely transversely aciculate, convex at the apex.

Length 9 millim.

Head dark æneous, nearly black, finely wrinkled and closely punctured, with a central deep elongate fovea, the interstices sparingly pubescent; eyes very deeply notched; antennæ black, extending to the base of the elytra, the terminal joints strongly widened and thickened, longer than broad; thorax rather long, the sides concave at the middle, the anterior angles produced into

¹ Ann. Mag. N. H. (6) xx. p. 215 (1897).

² 'Deer of all Lands,' p. 296 (1898).

1.

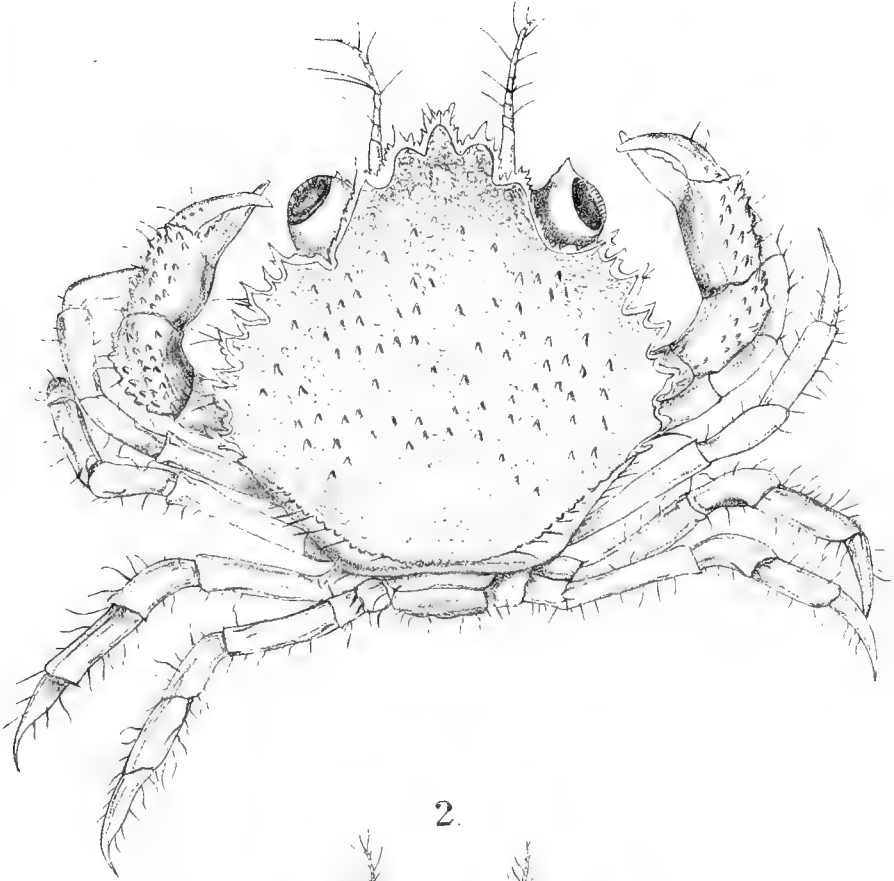

2.

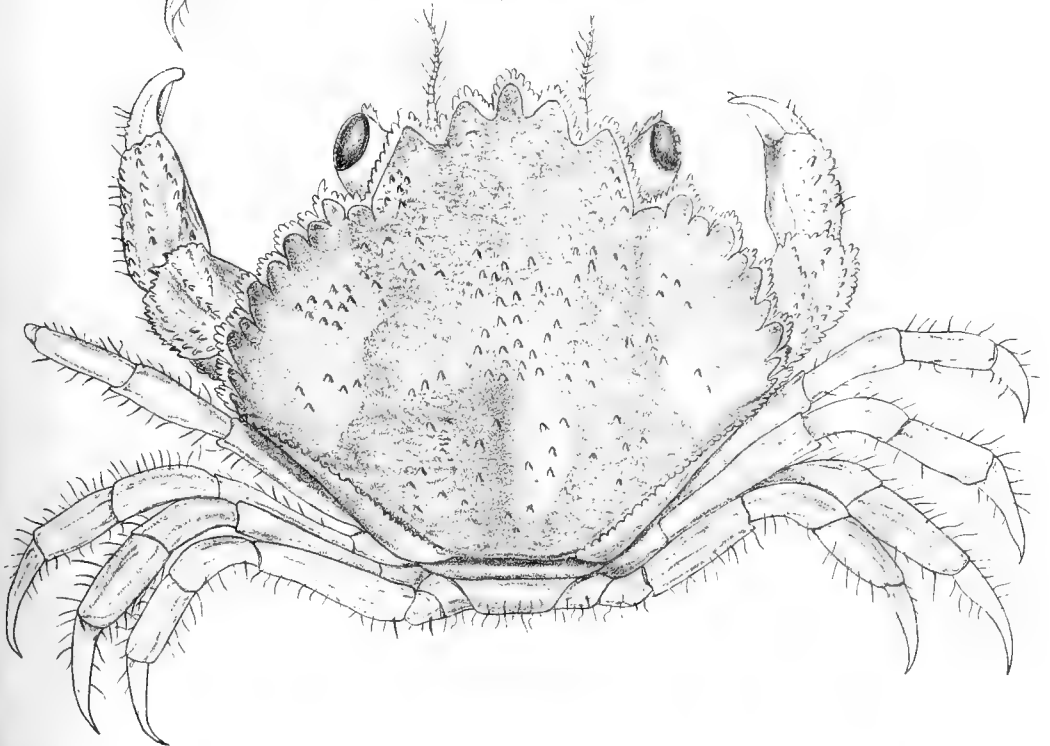



an acute tubercle, the middle of the disc with a broad band of deep punctures closely placed, ending in a fovea below, the base and the entire sides strongly transversely plicate, the anterior portion rugose-punctate; elytra dark fulvous, with ten rows of very regular-placed, mostly elongate deep punctures, which become smaller and closely approached near the apex, the interstices everywhere minutely aciculate or wrinkled, those at the apex strongly costate; underside and legs obscure æneous.

Hab. East Africa.

This species, of which a single specimen is contained in my collection, and another example in that of the British Museum, although closely allied to *L. dregei* Lac., which it resembles in the sculpturing of the thorax, seems quite distinct in regard to the colour and punctuation of the elytra, in which respect it likewise differs from *L. australis* Lac. and several of the allied forms. In *L. dregei* the elytra are of a greenish or bluish tint, the punctures are round and deep and less regularly placed; in the present insect the elytra are dark fulvous, extremely regularly punctured, the punctures are less deep and for the most part elongate, and the interstices are everywhere minutely aciculate, which is not the case in any of the allied forms from the same country; the thorax is also rather more elongate than usual, and the insect of larger size. I have given here a second description of this species, the original of which has been published in Italian by Dr. Gestro¹.

LEMA PICTICOLLIS, sp. nov.

Below black, above fulvous, the antennæ (the basal three joints excepted) and two spots on the thorax black; elytra moderately strongly punctured, the interstices impunctate; middle portion of the femora, the apex of the tibiæ, and the tarsi black.

Length 8 millim.

Parallel and cylindrical, the head very deeply constricted behind, the neck black, the rest fulvous, frontal tubercles strongly raised; antennæ rather short, black, the lower three joints and the base of the fourth fulvous; thorax as broad as long, the sides strongly and rather suddenly constricted at the middle, the anterior angles blunt, the surface entirely impunctate, with two black spots at the middle; scutellum fulvous; elytra with the basal portion slightly convex, strongly punctured at the same place, more finely so below, the punctures of elongate shape; underside black, the last abdominal segment flavous; legs fulvous, the greater portion of the femora at the middle and the apices of the tibiæ (more or less) and the tarsi black.

Hab. Salisbury, Mashonaland, at roots of grass, also Natal (*G. Marshall*).

Belonging to the larger groups of African species and closely allied to *L. emarginata* Baly and *L. robusta* Lac., but distinguished from either by the two black thoracic spots, the black underside, and other differences.

¹ Ann. Mus. Civ. Stor. Nat. Genova, (2) xv. p. 433 (1895).

LEMA ANGUSTO-MARGINATA, sp. nov.

Fulvous, the antennæ (the basal two joints excepted) and the tarsi black; thorax convex, closely punctured, stained with piceous anteriorly; elytra metallic blue, the extreme lateral margin near the apex and the latter narrowly fulvous.

Length 5 millim.

Head reddish fulvous, strongly punctured at the middle portion, the latter with a central groove; labrum black; the antennæ not extending to the middle of the elytra, black, the basal two joints fulvous, the first joint rounded and thick, the second very short, the third and fourth equal, the rest more elongate, pubescent; thorax not longer than broad, the sides moderately constricted at the middle, the anterior portion rather dilated, the angles not produced, the basal sulcus deep; the disc rather convex anteriorly, closely and rather strongly punctured, the punctures of different sizes, the space below the sulcus also closely punctate; scutellum fulvous; elytra metallic blue, very obsoletely depressed below the base near the suture, the punctures large, round and closely placed, especially so near the base, the interstices costate near the apex, the latter and the extreme lateral margin below the middle more or less fulvous; legs and the underside of the latter colour; the extreme apices of the tibiæ and the tarsi black.

Hab. Malvern, Ulundi, Natal, 5000–6000 ft. (*G. Marshall*).

Of this species three specimens are before me. From the many nearly similarly coloured African species, the present one may be known by the convex and rather swollen anterior portion of the thorax and its distinct punctuation, as well as by the colour of the tarsi. The species belongs to Lacordaire's first section with entire ninth row of elytral punctures. In all specimens the thorax has a piceous, rather large spot near the anterior angles, which in one are nearly connected, in this specimen there is also a similarly coloured central stripe and dark band behind the sulcus; it is therefore probable that specimens may be found with the thorax entirely dark coloured. *L. mashuana* Pering. seems closely allied, but is described with a smooth thorax and is larger in general size, the elytra are also entirely blue.

LEMA CYANEOPLAGIATA, sp. nov. (Plate XXII. fig. 2.)

Below blackish, pubescent, some spots on the head and the antennæ fulvous; thorax subquadrate, fulvous, finely punctured; elytra strongly punctate-striate, flavous, the suture, a spot on the shoulders, and a larger one below the middle bluish-black; legs fulvous.

Length 4 millim.

Head sparingly pubescent, strongly punctured, black, the vertex, a triangular space between the eyes, and the clypeus fulvous; antennæ robust, fulvous, each joint stained with piceous at the apex; thorax nearly subquadrate, the anterior portion rather suddenly constricted at the sides, nearly straight to the base, the basal sulcus moderately deep; the disc with another central

longitudinal groove, fulvous, sparingly punctured; scutellum obscure fulvous; elytra with strong and regular rows of punctures, the ninth row entire, flavous, the sutural margin, a small spot on the shoulders, and a large rounded spot near the apex at the sides bluish; legs robust, fulvous, the tarsal joints stained with fuscous at the apex; underside closely covered with silvery pubescence.

Hab. Charter, Mashonaland (*G. Marshall*).

The thorax in this species is of rather peculiar shape, short, subquadrate, and almost angularly constricted below the anterior portion and from there to the base nearly straight: this structure and the pattern of the elytra will assist in the determination of the species.

LEMA PUBIFRONS, sp. nov.

Testaceous, sides of the breast and the abdomen piceous; head clothed with golden pubescence; thorax with an anterior lateral sulcus, impunctate; elytra strongly punctate-striate, the ninth row entire, the interstices costate at the apex.

Length 3 millim.

Head pale fulvous, entirely clothed with very short, golden pubescence, the supraocular grooves moderately deep; antennæ extending to the middle of the elytra, testaceous, the third and fourth joints equal, the following joints thickened; thorax slightly broader than long, the anterior portion obliquely widened towards the apex, the angles not prominent, with a short seta, the basal sulcus deep, the sides with another short transverse groove near the middle; the disc entirely impunctate, testaceous; elytra with a short but distinct depression below the base, the punctures deep and large, of slightly elongate shape, the interstices costate at the sides and at the apex; underside clothed with fine silvery pubescence, the sides of the breast and the abdomen more or less piceous.

Hab. Malvern, Natal (*G. Marshall*).

At once to be distinguished from *L. pauperata* Lac. and *L. lateritia* Lac. by the golden-yellow pubescence which covers the head, together with its smaller size.

CRIOCERIS ELONGATA, sp. nov.

Elongate, subcylindrical, black, thorax closely and strongly punctured; elytra deeply and closely punctate-striate, piceous, the shoulders and the basal margin fulvous or flavous, interstices costate at the apex.

Length 8 millim.

Of more than usual elongate shape, the head with a deep central groove at the vertex, finely rugose near the eyes, the latter deeply notched, the emargination closely pubescent as well as the anterior portion of the head; antennæ short and robust, the terminal seven joints transversely widened, black; thorax subcylindrical, the anterior angles rounded, the sides but slightly constricted at the middle, the surface black, shining, strongly and irregularly but

rather closely punctured; scutellum black; elytra with the basal portion very slightly raised, strongly and closely punctate-striate, the punctures more closely approached towards the apex, the interstices costate at the same place, the disc piceous or nearly black, the shoulders with a narrow fulvous band extending a little way down the lateral margin as well as along the base; underside and legs black and sparingly pubescent.

Hab. Salisbury, Mashonaland (*G. Marshall*). Obtained by sweeping on kopjes.

The very elongate shape of this species and its system of coloration will assist in its recognition.

PÆCILOMORPHA HIRSUTA, sp. nov. (Plate XXII. fig. 1.)

Black, elytra fulvous or flavous, entirely clothed as well as the head and thorax with long yellow pubescence, arranged in shape of three narrow stripes on the head and the thorax; elytra with two small spots of thicker pubescence.

Length 6-8 millim.

Of posteriorly slightly narrow shape, densely clothed with long yellow hairs, the head black, the pubescence forming three narrow longitudinal stripes, not strongly marked; the clypeus separated from the face by a deep transverse groove; antennæ scarcely extending to the middle of the thorax, black, the terminal seven joints forming a strongly transverse broad club; thorax subcylindrical, rather short, black, the pubescence also arranged like that of the head and forming a lateral and central yellow stripe, when seen in certain positions; elytra pale fulvous, remotely and finely punctured, each puncture provided with a long black hair, the rest of the surface clothed with long yellow pubescence; underside blackish, densely pubescent; legs fulvous, tarsi blackish.

Hab. Umfuli River, Mashonaland (*G. Marshall*).

This species is more thickly covered with hairs than any of its congeners, and in certain lights two small pale spots at and below the middle are seen on the elytra, the latter spot extending also downward along the suture, as is the case in *P. tomentosa* Lac. I have seen three specimens of this species.

MELITONOMA MARSHALLI, sp. nov. (Plate XXII. fig. 5.)

Black, finely pubescent below, thorax fulvous, nearly impunctate; elytra deeply and coarsely punctured, fulvous, a transverse spot before the middle and a dentate band near the apex black; tibiæ and tarsi fulvous.

Length 5 millim.

Head black, finely strigose and pubescent between the eyes; antennæ black, the second and third joints fulvous; thorax strongly transverse, slightly narrowed anteriorly, the posterior angles rounded, the surface nearly impunctate, fulvous, the base with a short transverse groove in front of the scutellum and a few punctures at the same place; scutellum black; elytra subcylindrical, fulvous, closely impressed with large and deep punctures, the

extreme apex smooth, a large transverse slightly curved spot immediately before the middle not extending to either margin, and another equally broad and deeply dentate or angulate band near the apex, extending to the suture, black; underside and femora black, clothed with yellow pubescence; the tibiæ and tarsi fulvous, the latter rather robust, the first joint double the size of the second one.

Hab. Estcourt, Natal (*G. Marshall*).

The very strong elytral punctuation in connection with the shape of the bands will distinguish this species from any of its allies.

DAMIA MASHONANA, sp. nov.

Black, above reddish-fulvous, head and thorax shining, impunctate; elytra opaque, very closely and finely punctured and minutely granulate.

Length 3-4 millim.

Elongate and subcylindrical, the head entirely impunctate, reddish fulvous and shining, with an obsolete depression between the eyes; the epistome not separated from the face, its anterior edge very slightly concave; labium large and broad, fulvous, mandibles black; antennæ extending to the base of the thorax, black, the lower three joints are fulvous, the fifth and following joints strongly transverse; thorax short, twice as broad as long, the sides nearly straight, scarcely narrowed anteriorly, the posterior angles rounded, the surface with a transverse depression in front of the scutellum, this depression with a few punctures, the rest of the surface impunctate; scutellum broad, pointed at the apex, with an obsolete central ridge, impunctate, fulvous; elytra with a slight lateral basal lobe, of a darker fulvous colour than the thorax and opaque, very closely punctured, the interstices minutely granulate; underside and legs black, finely pubescent; all the legs elongate and slender, the first joint of the tarsi longer than the second, but scarcely so long as the following two joints together, the third joint two-thirds its length.

Hab. Salisbury, Mashonaland; Estcourt, Natal (*G. Marshall*).

The general appearance of this species agrees with *Gynandrophthalma*, but the elytra are slightly lobed at the base and the legs are slender and elongate, which agrees better with *Damia*; the absence of any darker markings on the thorax and elytra and the opaque and closely punctured and granulate surface of the latter will help to distinguish the species. I received two specimens from Mr. Marshall which he obtained by beating at Salisbury in October, also on acacia-flowers at Estcourt.

GYNANDROPTHALMA BICOLOR, sp. nov.

Elongate, subcylindrical, fulvous, thorax impunctate; elytra black, shining, extremely finely and sparingly punctured, with a narrow fulvous band at the apex, widened at the latter place.

Length 4-5 millim.

Head reddish-fulvous, with a few fine punctures between the eyes, the latter large, apex of the clypeus deeply semicircularly emarginate; antennæ extending to the base of the thorax, flavous, the third joint double the length of the second, the following joints strongly triangularly widened; thorax twice as broad as long, the sides nearly straight, distinctly narrowed towards the apex, the angles distinct, posterior margins nearly straight, almost without a median lobe, depressed in front of the latter and with a few punctures, rest of the surface impunctate, reddish fulvous, shining; scutellum of the same colour, longer than broad, its apex truncate; elytra with a shallow depression below the base, extremely minutely punctured in very irregular rows, visible only here and there under a strong lens, black, very shining, the apex with a narrow fulvous band extending a little way upward at the sides, where it gradually narrows; underside and legs pale fulvous, the first joint of the posterior tarsi as long as the following two joints together.

Hab. Salisbury, Mashonaland (*G. Marshall*).

Of the same coloration as *G. terminata* Lac., but larger, with entirely fulvous underside, the clypeus deeply emarginate, the apical spot not round but in shape of a band extending a little way upward: *G. hæmorrhoidalis* Lac. also differs in having the breast black and the elytra rugose; *G. basipennis* has the entire posterior three-fourths of the elytra fulvous; lastly, *G. deyrollei* Jac. has metallic blue, not black elytra. The three specimens sent by Mr. Marshall do not differ except in size.

GYNANDROPHALMA VARIPES, sp. nov.

Black, pubescent, thorax fulvous with two black spots, coarsely and sparingly punctured; scutellum black; elytra testaceous, distinctly punctured, the sides with a black longitudinal band not extending to the apex; legs black.

Fem.? Larger, the elytral suture black as well, more strongly punctured; legs fulvous.

Length 3-4 millim.

Head distinctly and rather closely punctured, finely pubescent, black, labrum fulvous; antennæ black, the lower four joints flavous; thorax more than twice as broad as long, the sides rounded, the posterior margin nearly straight, the surface very coarsely, irregularly and remotely punctured, fulvous, the sides with a transversely-shaped rather large black spot, emarginate at its upper edge; scutellum black, elongate; elytra rather finely and irregularly punctured, the punctures here and there arranged in rows, testaceous, the shoulders with a longitudinal narrow black stripe, abbreviated below the middle and not extending to the lateral margin; underside and legs black, clothed with yellowish pubescence.

Hab. Estcourt, Natal (*G. Marshall*).

Of the two specimens sent by Mr. Marshall, one is much larger, the head is more strongly punctured, and the entire lower portion is flavous as well as the legs, the suture is narrowly black to some distance from the apex, and the lateral stripe is broader and more

intensely black. This species is very closely allied to, if not identical with, *G. incerta* Lefèv., from Abyssinia, but that author gives the length as $4\frac{3}{4}$ –5 mm., and describes the thorax as having an ill-defined *central* black mark, of which there is no trace in my specimens; the elytral lateral stripe also is described as being placed below the middle. The punctuation of the thorax in the present insect is exceptionally strong and remote.

GYNANDROPTHALMA BABIODES, sp. nov.

Elongate, black, the thorax punctured near the base only; elytra finely punctured in irregular rows, black, the anterior half and a spot at the apex flavous.

Var. Elytra with the basal margin only as well as the apical spot fulvous.

Length 5 millim.

Head rather strongly punctured between the eyes, black, shining, the middle with three small foveæ, placed triangularly, the epistome semicircularly emarginate at its anterior edge, labrum and palpi black; antennæ with the second and the following two joints fulvous, the others black; thorax twice as broad as long, the sides nearly straight, slightly narrowed in front, the basal lobe scarcely produced, straight, the surface rather convex, irregularly and sparingly punctured, nearly impunctate anteriorly, more distinctly and closely punctured near the base, black, shining; scutellum rather broad, black; elytra elongate, subcylindrical and parallel, finely punctured in irregular rows, the anterior half and a spot at the apex flavous, the rest black; underside and legs black, the knees more or less fulvous; tarsi broad, the first joint scarcely longer than the second.

Hab. Salisbury, Mashonaland (*G. Marshall*).

A species evidently allied to *G. venustula* Lac., but larger, more elongate, the head not rugose but shining and punctured at the middle only, the thorax distinctly punctured near the base, and the elytral markings of different shape; in the variety the elytra are nearly black, leaving only the basal and part of the lateral margin as well as the apical spot fulvous. Like *G. venustula*, the present species resembles somewhat a species of the genus *Babia*.

GYNANDROPTHALMA NITIDICOLLIS, sp. nov. (Plate XXII. fig. 9.)

Black, pubescent, head and thorax bright metallic green, the latter impunctate; elytra pale fulvous, finely punctured in irregular rows, the suture narrowly and a broader lateral stripe, not extending to the apex, dark greenish.

Length 3–4 millim.

Head sparingly punctured and pubescent, metallic green, labrum obscure fulvous; antennæ with strongly serrate joints, fuscous, the lower three joints and the outer margin of the following three or four joints flavous, third joint very small; thorax nearly twice as broad as long, the sides rounded towards the base, the basal margin scarcely produced at the middle, the disc with a semicircular groove

near the anterior margin at the middle, impunctate, bright metallic green; scutellum black; elytra subcylindrical, pale fulvous, opaque, punctured in irregular remote rows, the suture and a longitudinal stripe at the sides, both abbreviated at the apex, dark greenish; legs flavous, rather long and robust, the anterior tarsi short, equal. Female larger, the legs shorter.

Hab. Estcourt, Natal (*G. Marshall*).

This species resembles several others of the genus in the elytral markings, all of them forming a little group of closely allied forms, but the present insect differs from all in the metallic green head and thorax; the elytral lateral band extends to the margins at its posterior portion.

MIOPRISTIS PUSILLA, sp. nov. (Plate XXII. fig. 7.)

Below black, pubescent, above fulvous; head black, pubescent, mandibles and lower joints of the antennæ flavous; thorax impunctate, fulvous; elytra finely and sparingly punctured, flavous; tarsi black.

Length $2\frac{1}{2}$ –3 millim.

Head rather strongly and closely punctured, sparingly pubescent, black; the epistome, labrum, and mandibles flavous, the apex of the latter black, the left one more developed than the other, strongly pointed and rather curved; antennæ rather long, extending to the base of the thorax, the lower four joints flavous, the rest black, the third and fourth joints equal, the remainder strongly transverse; thorax twice as broad as long, the sides very strongly rounded, the median lobe scarcely produced, nearly straight; the surface impunctate, shining, pale fulvous; scutellum black, its apex rather strongly raised and pointed; elytra narrower than the thorax, rather opaque, finely punctured in remote and irregular rows; the anterior legs very elongate, their femora strongly developed, the tibiæ strongly curved, the tarsi black, the first joint as long as the two following joints together.

Hab. Malvern, Natal (*G. Marshall*).

One of the smallest species of the genus, which may be also known by the black head and the absence of any markings on the thorax and elytra; the female has, as usual, a much narrower thorax and totally different and short legs, the anterior legs not exceeding the others in length; the elytra are also more shining and more strongly and closely punctured, and the general size is much smaller.

ANISOGNATHA QUADRIPLAGIATA, sp. nov. (Plate XXII. fig. 6.)

Bluish black below, finely pubescent, the anterior portion of the head, the thorax, and the tibiæ flavous; thorax impunctate; elytra finely and closely punctured, fulvous, an oblique spot at the base and a transverse spot below the middle blue.

Mas. The mandibles broad at the base, the left one much larger, strongly curved and produced into a long point inward.

Length 5 millim.

Elongate and parallel, the head impunctate, very sparingly pubescent, the epistome not separated from the face, the vertex bluish black with a small fulvous spot at the base, the entire lower portion pale fulvous, this colour forming a large oval patch, labrum of the same colour, mandibles black, the left one curved and strongly pointed in the male; the antennæ proportionately slender, black, the lower four or five joints fulvous, the third one smaller than the second, the fourth longer again, the following joints transverse, moderately widened, the apical joints smaller; thorax at least twice as broad as long, the sides strongly rounded as well as the posterior angles, the surface transversely convex, smooth and shining, flavous, impunctate; scutellum broad, pointed at the apex, black; elytra subcylindrical, less shining than the thorax, finely and closely punctured, with an oblique spot on the shoulder and another transverse and curved spot near the apex, dark blue; the underside, femora, the apex of the tibiæ, and the tarsi bluish black; the anterior legs elongate, as well as the tarsi, the first joint slightly longer than the second.

Fem. Head and mandibles of normal size, the tarsi less elongate.

Hab. Malvern, Natal (*G. Marshall*).

The structure of the mandibles and that of the legs seem to me to place this insect in Lacordaire's genus *Anisognatha*, which has been sunk into a synonym with *Gynandrophthalma* in Gemminger's Catalogue; but if the structure of the tibiæ and tarsi are of any value at all, *Anisognatha* has certainly nothing in common with the other genus and ought to be separated like many of the other genera of *Clythrinæ*, else the already exceedingly difficult determination of these insects becomes almost an impossibility.

Miopristis atrofasciatus Lac., likewise from Natal, resembles very nearly the present insect in shape and coloration, but the mandibles and the anterior legs and tarsi are differently structured, the tibiæ are black, the elytra are nearly impunctate, and the markings are of different shape and black.

ÆTHEOMORPHA CÆRULEA, sp. nov. (Plate XXII. fig. 8.)

Subcylindrical, metallic blue, pubescent below; legs fulvous, tarsi black; thorax strongly and irregularly punctured, obliquely depressed; elytra very closely and strongly punctured.

Length 6 millim.

Of parallel and cylindrical shape, dark metallic blue, the head strongly and rather closely punctured at the middle, the eyes large, the anterior edge of the clypeus semicircularly emarginate, labrum black; antennæ extending to the base of the thorax, black, the second and third joints obscure fulvous, very short, the other joints strongly transverse; thorax scarcely twice as broad as long, the sides nearly straight, gradually narrowed towards the apex, the posterior angles distinct, the disc rather strongly obliquely depressed at each side in front of the scutellum, the basal margin truncate at the same place, the surface strongly but irregularly punctured, rather closely so at the base, much more sparingly

anteriorly; scutellum large, smooth and shining, its apex slightly raised and truncate; elytra feebly lobed at the base, closely, strongly, and evenly punctured, covering the pygidium; legs fulvous, tarsi rather short and broad, the first joint but slightly longer than the second.

Hab. Salisbury, Mashonaland.

CAMPTOLENES ABYSSINICA Lefèv.

Two specimens obtained by Mr. Marshall at Salisbury, Mashonaland, agree so closely with Lefèvre's description that I must identify them with his species: the specimens before me are, however, smaller by 2 millim., and have entirely black antennæ and legs; the different localities probably account for this. In Donckier de Donceel's Catalogue of *Clythrinae* the species is placed in *Lachnea*; but in that genus the thorax is generally pubescent and the legs less elongate: *Camptolenes* is perhaps, therefore, a better place for the insect.

LACHNEA FULVICOLLIS, sp. nov.

Black, pubescent, the anterior portion of the head and the thorax fulvous, the latter rugosely punctured and pubescent; elytra opaque, strongly punctured and rugose, an angulate band before, another below the middle, and a spot at the apex, black.

Length 8 millim.

Head closely covered with yellowish pubescence, with a smooth, elongate, raised space between the eyes, the upper portion black; the clypeus entirely fulvous, its anterior edge feebly semicircularly emarginate; antennæ nearly extending to the base of the thorax, black, the fourth and following joints dentate or transversely widened; thorax twice as broad as long, the sides nearly straight, the posterior angles rounded, the surface strongly and unevenly punctured and rugose, entirely fulvous, sparingly clothed with yellow hairs; scutellum piceous, with a central obscure ridge, finely punctured; elytra very deeply and closely punctured, with one or two longitudinal short costæ near the apex, the basal margin in shape of transverse ridges, the ground-colour fulvous, an angular and oblique band before the middle not extending to either margin, another band below the middle not extending to the suture, the latter near the apex and a round spot at the last-named place, black; underside clothed with yellowish pubescence, the first tarsal joint as long as the following two joints together.

Hab. Niger-Benue Exped. (*Staudinger*).

The shape of the markings and perhaps the colour of the thorax in this species are probably as variable as is so frequently the case with these insects; but although I have only a single, apparently female specimen before me, it will be sufficient to recognize this species, which on account of the pubescence of the thorax, the colour of the latter, and the markings of the elytra cannot be confounded with other species of allied genera. Although *C. abyssinica* Lefèv. resembles the present insect as regards the elytral pattern,

the thorax is smooth in that species and of different coloration and the anterior legs are extremely elongate.

CRYPTOCEPHALUS NIGROFRONTALIS, sp. nov.

Flavous, the vertex of the head and the breast black, thorax finely and closely punctured, scutellum black; elytra strongly punctate-striate, the interstices finely punctured, flavous, a sutural and a sublateral stripe, the latter abbreviated at the apex, black.

Length 3 millim.

Head closely and rather strongly punctured, the vertex with a transverse black band, the lower portion fulvous; eyes but feebly notched; antennæ rather short, entirely fulvous, the terminal six joints widened, the second and third joints short, equal; thorax nearly twice as broad as long, the sides rather strongly rounded and narrowed towards the apex, the surface very finely and closely punctured, the punctures somewhat confluent at the sides, fulvous; scutellum broad, black, the surface with a few punctures; elytra with rather strong rows of punctures, the interstices finely punctured, the extreme basal margin, a sutural stripe, and a lateral stripe from the shoulder to near the apex black, the lateral margin likewise narrowly black from the middle to the apex; underside and legs flavous, the sides of the breast black.

Hab. Estcourt, Frere, Natal (*G. Marshall*).

Only half the size of *C. atrocinctus* Jac. and *C. africanus* Jac.; the head black at the upper portion, the thorax without markings, and the elytra with punctured interstices; the antennæ also are short and entirely fulvous; the lateral black elytral stripe is of slightly oblique shape and directed towards the suture.

CRYPTOCEPHALUS EPIPLEURALIS, sp. nov. (Plate XXII. fig. 3.)

Fulvous below, head and thorax rufous, the latter with the anterior and lateral margins narrowly flavous, a transverse basal band black; elytra black, finely punctate striate, the lateral margins anteriorly and the epipleuræ flavous; legs fulvous.

Length 4-5 millim.

Head strongly punctured at the vertex and near the eyes, the former black, with a short central groove, the lower portion rufous, the emargination of the eyes flavous, edged with black, the clypeus and the labrum flavous; antennæ extending to the middle of the elytra, fulvous, the terminal four joints fuscous, the latter very elongate, the third joint double the length of the second, but slightly shorter than the fourth; thorax nearly twice as broad as long, strongly narrowed in front, the sides rounded at the base and slightly protruding at that place beyond the elytra, the surface sparingly and extremely finely punctured, rufous, the anterior and lateral margins extremely narrowly flavous, preceded by the black outer edge, the base with a broad black band, which is sometimes reduced to two spots and greatly narrowed at each side; scutellum black, broad, its apex rounded; elytra with five rows of punctures, which are nearly obsolete at the base and apex, the

interstices flat and with some minute punctures, black, shining; a narrow spot below the scutellum, the outer edge and part of the epipleuræ to below the middle, yellowish white; underside fulvous, clothed with whitish hairs, tibiæ and tarsi paler.

Hab. Estcourt, Natal, on *Acacia horrida* (*G. Marshall*).

Of this species there are at this moment before me, from different parts of Natal, nine specimens, which only vary in the number of spots on the thorax, the latter being either entirely rufous, or rufous with two black central spots, while in several there is only a transverse basal black band of variable width without the other spots; the head is likewise variable in regard to colour, sometimes entirely fulvous, or with the vertex and a small spot at the base of the antennæ black, and the sides narrowly edged with flavous. Although Suffrian has looked upon the present species as a variety of his *C. sulcifrons*, the similar coloration of all the specimens before me and the absence of any intermediate forms, which are neither given by Suffrian nor have come under my notice, induces me to consider the insect as specifically distinct; the frontal sulcus of the head is only well pronounced in one specimen, but in others very feebly so, and no more than in many other species; in nearly all the specimens there is a sutural short yellowish stripe below the scutellum, which sometimes surrounds the latter.

ACOLASTUS NIGROPLAGIATUS, sp. nov. (Plate XXII. fig. 4.)

Black, finely pubescent, head with two flavous spots; thorax pubescent, closely punctured, flavous, with a lateral band and a central black spot; elytra closely rugose, a spot on the shoulder, a larger one near the scutellum, another one at the sides, the suture, and a transverse short band connected with the latter, black; legs black and flavous.

Length 3 millim.

Head broad, closely and rather strongly punctured and sparingly pubescent, black; two spots between the eyes, the clypeus, and the labrum flavous; eyes large, very moderately emarginate; antennæ not extending much farther than the base of the thorax, thin and slender, the third and fourth joints equal, the following joints slightly longer, the lower five joints more or less flavous, the others black; thorax more than twice as broad as long, the sides rounded near the base and gradually narrowed anteriorly, posterior margin truncate at the middle, the surface extremely closely and rather strongly punctured, almost rugose, clothed with fine white pubescence, flavous, the sides with an oblique irregular-shaped black band not extending to the apex and connected at the base with a central spot of subquadrate shape; scutellum broad, its apex pointed, the surface black, pubescent; elytra finely rugose throughout, the basal margin in shape of a transverse ridge, the apex with some very short costæ, the suture black, this colour widened into a short transverse band near the apex, a small spot placed on the shoulder, a larger one near the scutellum, and an elongate spot at the lateral margin below the middle black; under-

side and the pygidium black, clothed with whitish pubescence; legs either almost entirely black or the tibiæ and tarsi more or less flavous, sometimes entirely so; prosternum very narrow, with a central longitudinal groove.

Hab. Estcourt, Natal (*G. Marshall*).

Of this genus, four species have up till now been described by Gerstaecker and Suffrian. The present insect seems very closely allied to *A. pictus* Suffr., but is smaller, the thorax of totally different shape (Suffrian gives the size of the thorax in *A. pictus* as one half longer than broad, which is evidently meant to be the opposite), the elytra with only a short transverse sutural spot below the middle, not with a strongly dentate band as in *A. pictus*. I have seen four specimens, which were obtained by Mr. Marshall.

ACOLASTUS TUBERCULATUS, sp. nov.

Below piceous, clothed with white pubescence, above dark fulvous with yellow tubercles, sparingly pubescent, apical joints of antennæ black; thorax and elytra closely punctured, rugose, and with tubercles, apex of elytra with a transverse smooth raised space.

Length 3 millim.

Head closely rugose and clothed with white pubescence, fulvous, or more or less black; the eyes very large and closely approached in the male, but slightly emarginate; antennæ slender, extending to the middle of the elytra, black, the lower four joints flavous; thorax about one-half broader than long, narrowed in front, the whole surface closely covered with rugosities and deep punctures, partly of flavous colour, the rest fulvous and clothed with very short white pubescence; scutellum broad, pointed at the apex, black, finely pubescent; elytra wider at the base than the thorax and sculptured exactly like the latter, likewise clothed with short white pubescence, the apex with a transverse, smooth, raised space, the shoulders in one specimen with a black spot; underside obscure fulvous or piceous, densely clothed with silvery hairs; legs fulvous, the anterior femora strongly thickened, their tibiæ slightly curved; prosternum very narrow and elongate, convex, pubescent.

Hab. Salisbury, Mashonaland, obtained by beating (*G. Marshall*).

Much narrower than the preceding species and resembling entirely a species of *Pachybrachys* in general appearance; the prosternum is, however, of different shape, but has not the central groove of the other species. *A. malvæ* Suffr. seems closely allied, but differs in having dark bands on the thorax and the elytra, and scarcely a raised smooth space at the apex of the latter, nor does Suffrian mention any pubescence of the elytra.

Cryptocephalus unicinctus Jac. P. Z. S. 1897, p. 259, = *C. africanus* Jac. Trans. Ent. Soc. Lond. 1895, p. 168.

Cryptocephalus bimaculicollis Jac. P. Z. S. 1897, p. 259, = *C. angustofasciatus* Jac. Trans. Ent. Soc. Lond. 1895, p. 169.

I have noticed, unfortunately too late, that these two species

have been twice described by me under different names; the names of 1895, being the older, ought to be retained.

CHEIRIDISIA, gen. nov. (*Eumolpidæ*).

Oblong, subcylindrical, pubescent; antennæ filiform; thorax broader than long, subdepressed, the sides rounded, strongly serrate; elytra alutaceous, minutely punctured in rows and pubescent; legs slender, the femora dentate, the intermediate tibiæ deeply emarginate at the apex, claws bifid; prosternum elongate, very narrow, convex; the anterior margin of the thoracic episternum concave.

The insect for which this genus is proposed can only be compared to *Cheiridea* Baly on account of the filiform antennæ and the emargination of the intermediate tibiæ only, but the thorax is not subglobose, the sculpture of the upper parts is totally different, and the femora are all armed with a tooth; one or other of these differences separates the genus also from *Nerissus*, *Nerissidius* Weise, and *Stratioderus* Weise. The present little insect is interesting in another respect, for the sculpture of the head and thorax is very peculiar and unlike any other with which I am acquainted among the enormous numbers of Phytophaga. It may be compared in a miniature way to the skin of a crocodile, the surface being divided into numerous small fields, between which single hairs are placed at regular intervals.

CHEIRIDISIA INORNATA, sp. nov. (Plate XXII. fig. 10.)

Black, opaque, the basal joints of the antennæ and the tibiæ and tarsi fulvous; head and thorax impunctate, coriaceous, pubescent; elytra minutely granulate, scarcely perceptibly punctured, furnished with rows of white hairs.

Length 3 millim.

Head broader than long, without punctures, sparingly clothed with whitish rather long hairs; the clypeus not separated from the face, bounded at the sides by a distinctly raised, short, perpendicular ridge; labrum and mandibles dark fulvous, palpi slender; antennæ extending beyond the middle of the elytra, flavous, the terminal joints fuscous, basal joint subquadrate, thickened, second one-half the length, the third one-half longer, the following joints more elongate; thorax about one-half broader than long, slightly narrowed at the base, the sides strongly rounded, with a regular row of large teeth, the surface sculptured like the head, opaque, without punctures, clothed with long whitish hairs; scutellum subpentagonal, pubescent; elytra smaller than the thorax at the base, finely coriaceous, obsoletely depressed below the base, the disc with rows of extremely fine punctures and of stiff white hairs; femora and underside black, tibiæ and tarsi fulvous, the metatarsus of the posterior legs nearly as long as the following joints together.

Hab. Salisbury, Mashonaland (*G. Marshall*).

In one specimen the underside and legs are entirely fulvous.

PSEUDOMALEGIA FULVIPES, sp. nov.

Black, clothed with white pubescence, basal joints of the antennæ and the legs fulvous; thorax finely rugose, elytra distinctly punctured in irregular rows.

Length $2\frac{1}{2}$ millim.

Of an opaque black colour; the head rugose, clothed with white pubescence; the clypeus not separated, rather deeply concave; mandibles fulvous at the base; antennæ rather short, fulvous, the terminal joints slightly darker, the basal two joints swollen, the second one-half the length of the first, the following four joints more elongate and slender, the others thickened; thorax subquadrate, scarcely wider than long, without distinct lateral margin, the surface finely rugose and clothed with rather long white pubescence; elytra wider at the base than the thorax, distinctly punctured in closely-approached, irregular rows, the interstices furnished with long white pubescence arranged in lines; below black, legs entirely fulvous, the tibiæ not emarginate, claws bifid.

Hab. Malvern, Natal (*G. Marshall*).

This species agrees in the non-emarginate tibiæ with *P. lefevrei* Jac., the only other species of the genus. It differs from this and any of its close allies of the genus *Malegia* in the entirely black colour, which shows no trace of a metallic gloss, and in the fulvous legs; the latter in one specimen, however, are stained with piceous.

MALEGIA AFFINIS, sp. nov.

Below yellowish cupreous, finely pubescent, above obscure cupreous, the basal joints of the antennæ and the legs fulvous, tarsi black; thorax finely rugose and pubescent, elytra finely punctured, with white pubescence arranged partly in shape of bands.

Length 3 millim.

Head finely and closely punctured, clothed with white hairs; labrum black, lower joints of palpi fulvous, the apical one black; antennæ with the lower six joints fulvous, the rest black; thorax narrowed anteriorly and posteriorly, closely and finely rugose-punctate and pubescent, the hairs arranged at the middle into a narrow, more or less distinct stripe; scutellum closely pubescent; elytra much wider at the base than the thorax and nearly similarly punctured, obscure cupreous, clothed with short white pubescence, which is arranged somewhat in the shape of two transverse bands before and below the middle, near the apex a small whitish spot of hair and another angular band of pubescence can be traced; underside of a more brassy tint; legs robust, fulvous, the intermediate tibiæ slightly emarginate at the apex, the tarsi black, claws bifid.

Hab. Frere, Natal; on acacia flowers (*G. Marshall*).

This species differs from *M. striatula* Lefèv. in the different elytral sculpture and colour of the legs, and from *M. obscurella* Lefèv., so far as one can judge from a four-lined description, in its larger size and the arrangement of the pubescence on its upper surface as well as by the fulvous femora.

SCELODONTA PECTORALIS, sp. nov.

Reddish cupreous, finely pubescent, terminal joints of the antennæ and the tarsi black; head strongly punctured; thorax transversely strigose; elytra coarsely punctate, the posterior portion finely longitudinally costate; sides of the breast densely pubescent.

Length 4 millim.

Head strongly rugose, the interstices sparingly clothed with single white hairs, the middle with a longitudinal groove, the lateral sulci very deep; clypeus sculptured like the head, its anterior margin nearly straight, palpi æneous; antennæ with the lower four joints æneous or cupreous, the rest black; thorax one-half broader than long, the sides rounded, the whole surface transversely wrinkled or plicate, without distinct punctures; scutellum pentagonal, sparingly pubescent and punctured; elytra broader at the base than the thorax, obsolete depressed below the former, the entire anterior half densely and strongly rugose-punctate, the interstices transversely rugose, clothed with single white hairs, semiregularly placed, those near the apex distinctly costate; the sides of the breast with a stripe of dense white pubescence; femora with a minute tooth.

Hab. Estcourt, Natal (*G. Marshall*).

This *Scelodonta* is evidently closely allied to *S. raffrayi* Lefèv., if not identical, but the latter insect is described as metallic green above and of larger size; and as the two specimens before me agree in every detail I cannot identify them with Lefèvre's species, nor with any other, on account of sculptural or other differences. All these forms are very closely allied and can only be recognized by a detailed description of all essential parts of the insect; *S. inæqualis* Fairm. seems to differ in the sculpturing of the upper parts and in the absence of the tomentose stripe on the breast.

PSEUDIVONGIUS ÆNEUS, sp. nov.

Dark greenish æneous, the basal joints of the antennæ and the four anterior legs fulvous; thorax minutely punctured; elytra extremely finely punctured in obsolete rows, the apex impunctate.

Length 2 millim.

Head minutely granulate and very finely punctured, greenish; the clypeus not separated from the face, deflexed anteriorly, its anterior margin with a small emargination at the middle, labrum fulvous; eyes very widely separated, surrounded with a very narrow sulcus above; antennæ extending slightly beyond the middle of the elytra, black, the lower four joints fulvous, basal joint thickened, the second slightly shorter but as long as the following joints, the terminal ones distinctly thickened; thorax three times broader than long, the sides deflexed, the lateral margins nearly straight, the angles distinct, the surface extremely finely granulate and minutely punctured; elytra widened at the middle, pointed at the apex and very convex, the shoulders rounded, the surface very finely aciculate or wrinkled, with closely-approached rows of minute punctures, invisible at the apex, the interstices impressed

with very fine longitudinal lines; femora thickened, æneous, tibiæ and tarsi fulvous, the posterior ones darker, the first joint of the posterior tarsi nearly as long as the following two joints together, the anterior tarsi broader and shorter.

Hab. Frere, Natal, also Mooi River (*G. Marshall*), obtained by sweeping.

Differing from *P. natalensis* Jac. in the much more ovately rounded shape, the very strongly transverse thorax, and the entirely different punctuation of the upper surface, also in the shorter legs.

PSEUEDUSIA, gen. nov.

Body subcylindrical, glabrous; antennæ filiform, widely separated; thorax transversely subcylindrical; elytra finely transversely rugose and irregularly punctured; legs slender, anterior femora strongly widened into a tooth; tibiæ mucronate, not emarginate, claws appendiculate; prosternum longer than broad, convex, its apex truncate; the anterior margin of the thoracic episternum very slightly convex.

The exact position for this Eumolpid is not easy to find, since the shape of the anterior margin of the thoracic episternum is not well defined, as is frequently the case in the present group, leaving it often a matter of doubt to which section, according to our present classification, the insects should be referred. In the present case the slight convexity of this margin places the species in the second division of the Eumolpidæ, and near *Argoa* Lefèv. (*Argolis* Chap.), which has likewise the anterior femora dilated into a tooth; there is also the same dilatation of the anterior tibiæ in the present species, although not to the same extent as in *Argoa*; from that genus the shape of the antennæ, that of the thorax, and other details separate *Pseudedusia*.

PSEUEDUSIA FULVIPES, sp. nov.

Below obscure piceous, above metallic green or æneous, antennæ and legs fulvous, thorax finely and subremotely punctured, elytra strongly punctate and transversely rugose.

Length 5 millim.

Head broad, remotely and finely punctured, metallic green with a cupreous tint, longitudinally depressed at the middle; clypeus not separated from the face, its anterior edge nearly straight, more strongly punctured than the head; labrum transverse, fulvous; mandibles robust, fulvous, the apex black, palpi slender, fulvous; antennæ very widely separated, slender, extending beyond the middle of the elytra, fulvous, the first joint thickened, slightly curved and rather short, the second joint thin, one-third shorter than the third, the terminal five joints shorter and very slightly thickened; thorax subquadrately transverse, of equal width, the sides nearly straight, the angles acute but not produced, the surface subcylindrical, metallic greenish-æneous, finely and subremotely punctured; scutellum ovate; elytra subcylindrical more

strongly punctured than the thorax, the punctures closely placed near the suture, the interstices towards the sides transversely rugose; legs fulvous, the anterior femora much thickened and dilated into a tooth.

Hab. Salisbury, Mashonaland (*G. Marshall*), obtained by beating in September.

In the female the thorax is slightly narrowed in front, and the antennæ are much shorter and have the third and fourth joints of equal length, the apical ones are slightly stained with fuscous.

PSEUDOCOLASPIS COSTATA, sp. nov. (Plate XXII. fig. 12.)

Metallic green, the femora and tibiæ more or less cupreous; thorax transversely rugose, with a narrow lateral cupreous band; elytra with deep basal depression, strongly punctate-striate, the interstices very strongly longitudinally costate.

Length 5 millim.

Head very closely rugose-punctate, the interstices minutely granulate, metallic green, a narrow margin round the eyes and the sides of the clypeus reddish cupreous; clypeus not separated from the face, deeply punctured, its anterior edge concave, palpi piceous; antennæ dark blue or purplish, the last five joints very robust and strongly thickened; thorax subcylindrical, constricted anteriorly and posteriorly, the surface closely and deeply punctured, the interstices everywhere transversely rugose, the middle of the disc slightly depressed, bright metallic green, the sides with a narrow cupreous band; scutellum subpentagonal, with a few punctures; elytra much wider at the base than the thorax, the shoulders acutely raised, the basal portion with a deep transverse depression which is closely punctured, the base itself also with irregular rows of strong punctures which become more obsolete below the depression, each elytron with about eight strongly-raised costæ, metallic green, the sides narrowly purplish; underside and legs metallic green, the apex of the femora and the tibiæ more or less cupreous, tarsi purplish.

Hab. Camerouns (*Conrad*).

This is a handsome species, well distinguished by the system of coloration and the strong elytral costæ; I received a single specimen from Dr. Kraatz. *P. cupreo-marginata* Jac. is nearly identical in coloration, but the elytra have no depression and the sculpture is entirely different, yet it is not impossible that the present insect is only the male of the one last named.

PSEUDOCOLAPSIS LATERALIS, sp. nov.

Fuscous, the basal joints of the antennæ and the tibiæ and tarsi fulvous; thorax finely and closely punctured, with silvery-grey hairs, its anterior margin fulvous; elytra finely punctured, with rows of stiff hairs, the disc obscure metallic, the sides broadly fulvo-piceous; femora mucronate.

Length 5 millim.

Head deeply rugose-punctate, the middle with a small tubercle,

cupreous, finely pubescent; clypeus with the anterior margin straight; mandibles robust, fulvous; antennæ short, fulvous, the seventh joint enlarged, widened, the terminal four joints transverse; thorax obscure cupreous, finely and closely punctured, distinctly narrowed at the base only, with a very obsolete transverse depression at the sides near the anterior margin, the latter narrowly fulvous at the middle, the disc clothed with silvery hairs; scutellum subpentagonal, pubescent; elytra with a short but rather deep depression below the base, punctured like the thorax, the interstices with rows of short silvery-grey hairs and longer black stiff ones, irregularly distributed, the disc in the shape of a triangular ill-defined patch, obscure metallic bluish, the sides and apex obscure fulvous with a slight metallic gloss; legs obscure piceous, the tibiæ and tarsi dark fulvous.

Hab. Wernen, Natal (*G. Marshall*).

A species of peculiar coloration, of which I have two specimens before me agreeing in all details; they resemble somewhat in their system of coloration *P. discoidalis* Jac., from India. The thorax in *P. lateralis* is distinctly narrowed only at the base and its anterior margin stained with fulvous, which will assist in the recognition of the species; all the femora are armed with a distinct tooth; in one of the specimens the terminal four joints of the antennæ are fuscous.

PSEUDOCOLASPIS LATICOLLIS, sp. nov.

Obscure cupreous, finely pubescent, tibiæ and tarsi fulvous; thorax very broad, the sides strongly swollen, minutely and closely punctured, with three bands of fine white pubescence; elytra as finely punctured, with two longitudinal white pubescent stripes.

Length 6 millim.

Head finely and closely punctured and pubescent, with a longitudinally divided tubercle at the middle, the clypeus very deeply semicircularly emarginate at the anterior edge, its sides raised into an acute ridge; thorax twice as broad as long, the sides strongly rounded, the disc greatly swollen at each side, with a transverse sulcus near the anterior margin, the surface evenly, closely, and finely punctured, with a band of thin white pubescence at the sides and the middle; scutellum broadly subquadrate, closely punctured and pubescent; elytra broad and short, only about one-half longer than the thorax, the apex broadly rounded, sculptured and pubescent like the thorax, the hairs forming a longitudinal streak at the sides and another at the middle of the disc, the shoulders moderately prominent below, and the legs equally clothed with white pubescence; posterior femora with a small tooth, the others unarmed, the tibiæ dark fulvous, the anterior ones rather curved.

Hab. S. Africa (*Drege*).

Of this species, remarkable for the deeply emarginate clypeus and the swollen disc of the thorax, I possess a single specimen, unfortunately without the antennæ; it was obtained years ago by the African collector Drege, but seems not to have been described,

as the late M. Lefèvre, to whom I submitted the specimen, did not know it; the pubescent white bands of the thorax and of the elytra can only just be distinguished in my specimen, which is probably somewhat rubbed.

PAUSIRIS (COLASPIDEA) ARACHNOIDES Duviv.

This species, of which I possess a typical specimen, is not a *Colaspidea* on account of the distinctly concave thoracic episternum, but must be placed in *Pausiris* Chap.

TRICHOSTOLA LEFEVREI, sp. nov.

Greenish æneous, clothed with white pubescence, the tibiæ fulvous, antennæ fuscous, thorax and elytra very closely and irregularly punctured.

Length 3 millim.

Head very finely punctured, clothed with long whitish hairs, terminal joints of the palpi black; antennæ extending to about the middle of the elytra, rather robust, fulvous, each joint stained with fuscous at its apex, the second joint thickened, but very little shorter than the following four joints, the others thickened; thorax more than twice as broad as long, the sides straight and obliquely narrowed towards the apex, the posterior margin nearly straight, the surface finely and closely punctured, clothed with whitish hairs; scutellum subpentagonal, densely pubescent; elytra with a very shallow depression below the base, scarcely more strongly punctured than the thorax, the punctures closely and irregularly placed, the interstices pubescent like the other parts; femora more or less æneous, tibiæ and tarsi obscure fulvous, pubescent.

Hab. Pine Town, S. Africa.

This species is one of the few in which the elytra are irregularly punctured, and is evidently closely allied to *T. fuscitarsis* Chap.; but the latter species is described as having the pubescence golden yellow, which is not the case here, nor are the legs ferruginous.

COLASPOSOMA SEMIHIRSUTUM, sp. nov.

Metallic green, the basal three joints of the antennæ and the legs fulvous, head and thorax strongly and closely punctured; elytra more closely punctured than the thorax, the interstices transversely rugose throughout and sparingly clothed with very short grey pubescence.

Length 6 millim.

Head very strongly but not very closely punctured, metallic green; the clypeus not separated from the face, bounded at the sides by a strongly raised ridge; labrum fulvous as well as the basal joints of the palpi, base of the mandibles metallic green; antennæ extending to the middle of the elytra, fuscous, the lower three joints fulvous; thorax rather more than twice as broad as long, the sides evenly rounded, the angles acute, the surface closely and very strongly punctured, the punctures round and deep, of equal size,

the middle of the disc with a narrow smooth space; scutellum with a few fine punctures, scarcely broader than long; elytra rather elongate in the male, slightly wider at the base than the thorax, with a very shallow depression below the base, sculptured like the thorax, but the punctures much more closely placed, the interstices everywhere finely transversely rugose and clothed with very short white hairs when seen sideways; underside metallic green, the breast finely wrinkled and pubescent as well as the prosternum; legs fulvous, the anterior ones elongate in the male, the tarsi more or less piceous.

Hab. Maritzburg, Natal.

C. semihirsutum differs from any of its numerous congeners in the strong punctuation of the thorax, the transverse rugosities of the elytra, which are not only confined to the sides but also to the disc in the male, and the short pubescence, which can be seen only when the insect is viewed sideways; the female differs only in the shorter anterior legs and less transverse thorax. There are three specimens in my collection, which are all of a bright metallic green colour.

COLASPOSOMA MARSHALLI, sp. nov.

Brownish or greenish æneous, finely pubescent, basal joints of the antennæ fulvous, thorax rugosely punctured; elytra transversely rugose throughout, the interspaces deeply punctured.

Length 4-5 millim.

Head strongly and closely punctured, purplish, with a smooth central cupreous space, the anterior portion obsoletely depressed; antennæ fulvous, the upper joints more or less stained with greenish æneous, four terminal joints widened; thorax more than twice as broad as long, the sides slightly widened towards the base, nearly straight, the disc closely and deeply punctured, the interstices rugose, the middle with a short smooth narrow space, each puncture provided with a very short white hair; scutellum cupreous, broader than long, with a few punctures; elytra slightly widened towards the apex, closely covered with transverse rugosities, the interstices with some deep punctures and sparingly clothed with short whitish pubescence; the underside more or less metallic and similarly pubescent, the abdomen and the legs fulvous with metallic gloss.

Hab. Salisbury, Mashonaland (*G. Marshall*).

Among the African species of *Colasposoma* having the thorax more or less clothed with pubescence, the present species is distinguished by the peculiar brownish æneous colour of its upper surface, with shades of metallic green here and there, and by the entirely rugose elytra, in which the rugosities extend quite to the suture. Two specimens are before me, agreeing in all details.

COLASPOSOMA PLUMBEUM, sp. nov.

Dark violaceous blue or bright green, finely pubescent, the antennæ black; thorax strongly and rather closely punctured; elytra

similarly punctured, the interstices everywhere transversely rugose, sparingly pubescent.

Fem. Larger, obscure æneous, the sides with a row of tubercles.

Length 4-5 millim.

Of subcylindrical parallel shape, of a leaden blue or light green colour; the head minutely granulate, rather closely and strongly punctured; the labrum, the base of the mandibles, and that of the palpi more or less fulvous, apical joint of the latter black; antennæ long and slender, black, the basal two joints fulvous below, the first one metallic green above, the extreme apex of the following joints flavous, terminal joints slightly thickened, much longer than broad; thorax twice as broad as long, the sides rounded, very slightly narrowed towards the apex, the angles distinct but not produced, the surface convex, rather closely impressed with deep round punctures, the interstices with some very short white hairs, more distinctly visible near the margins; scutellum with a few deep punctures; elytra very similarly sculptured as in the preceding species, the shoulders smooth, round and raised; underside and legs metallic blue, more shining than the upper surface and clothed with much longer pubescence, the coxæ fulvous.

Hab. Tugela River near Wernen, Natal (about 2500 ft.) (*G. Marshall*).

Like the preceding, the present species is clothed with very short pubescence visible only under a strong lens, and the elytra show the same rugosities throughout, but the former are not in the least widened posteriorly and are parallel; the thorax is differently sculptured, without rugosities, and the general colour is that of an opaque purplish-blue or green. The female does not differ in any way, but is larger, of a darker æneous colour, and the sides are furnished with a row of tubercles, forming a ridge from the shoulders nearly to the apex.

COLASPOSOMA PUBIPENNE, sp. nov.

Æneous, finely pubescent, the labrum, antennæ, and the legs fulvous; thorax extremely closely and rather finely punctured; elytra more strongly and remotely punctured, finely pubescent, the sides with a transverse deep depression below the base, finely wrinkled.

Length 6 millim.

Of a dark bronze colour; the head very closely and distinctly punctured; the clypeus not separated from the face, semicircularly emarginate anteriorly, the whole surface sparingly clothed with white pubescence; labrum fulvous; antennæ extending to the middle of the elytra, fulvous, the basal joint short and thick, the second shorter than the third, the following more elongate, the last four joints distinctly thickened, extreme apex of the last joint black; thorax three times as broad as long, convex, the sides rounded, clothed with white pubescence, the surface extremely closely and finely punctured; scutellum broader than long, with a few punctures; elytra closely, evenly, and more strongly punctured

than the thorax, with a deep transverse depression below the base, the shoulders prominent, the sides finely transversely rugose and pubescent; underside more or less cupreous, finely pubescent; legs and tarsi dark fulvous; prosternum very broad, finely punctured.

Hab. Wernen, Natal (*G. Marshall*).

This is another species with pubescent upper surface, although the hairs in the specimens before me are only visible at the sides, where they are, however, very distinct. The specimens sent by Mr. Marshall seem all to belong to the female sex. *C. bouvouloiri* Lefèv. is of a violaceous tint, has nearly black tarsi or legs, posteriorly dilated elytra, and longitudinal strigæ at the sides of the latter (♀?). *C. thoracicum* Lefèv. has no elytral basal depression and is of different coloration. *C. villosum* Lefèv. is much larger and of quite different coloration, the pubescence is shorter and denser, and the elytra have a cupreous margin. *C. vestita* Thoms. is described as having a thorax nearly as long as broad, and probably belongs to another genus. *C. melancholicum* Jac. belongs also to the pubescent group, but has elytral smooth spaces or costæ. Lastly *C. pubescens* Lefèv. is quite differently shaped, with very fine punctures and pubescence covering the entire upper surface.

MECISTES INDIGACEUS, sp. nov.

Subcylindrical, convex, dark bluish, the basal joints of the antennæ fulvous; thorax closely and distinctly punctured, clothed with very short pubescence; elytra subgeminately punctate, the interstices forming smooth narrow spaces, with short pubescence.

Length 4 millim.

Head extremely closely punctured, nearly subrugose, the clypeus not separated from the face, the sides constricted and forming acute ridges; antennæ very short, the basal two and the terminal five joints black, the others fulvous, the third joint rather longer than the preceding and the following two joints, the terminal ones nearly as broad as long, strongly thickened; thorax subcylindrical, about one-half broader than long, the sides strongly deflexed, the lateral margins nearly straight, the surface very closely impressed with rather large, round punctures, each puncture furnished with a very short white hair; scutellum broad, its apex produced into a lobe at the middle; elytra much broader at the base than the thorax, strongly punctured in irregular double rows, the interstices raised into smooth, longitudinal, narrow spaces, more or less distinct and furnished with very short white hairs, arranged in rows, at the sides; a costa, not strongly marked, extends from the shoulders to the apex; legs and the underside coloured as the upper surface, but the breast and abdomen with a more or less distinct metallic purplish or cupreous tint; the femora very strongly, the underside less strongly punctured; the prosternum very broad, longitudinally sulcate at the sides, the anterior margin of the thoracic episternum strongly convex.

Hab. Ulundi, Natal, obtained by sweeping (*G. Marshall*).

Two species are contained at present in this genus, both from

South Africa, and both characterized only by short diagnoses. One of them, *M. tarsalis* Chap., seems closely allied in many respects to the present insect, but differs in the colour of the upper surface and that of the tarsi, while the under surface is described as black; the species obtained by Mr. Marshall is entirely of a dark blue colour with a cupreous-tinted underside. The genus is well characterized by the short antennæ, the scale-like pubescence, and the structure of the prosternum.

SYAGRUS MARSHALLI, sp. nov.

Fulvous, intermediate joints of the antennæ fuscous, thorax semi-rugose punctate; elytra deeply punctate-striate, the interstices costate, a round spot before and an elongate one below the middle (sometimes connected) black; femora with a strong tooth.

Length 5 millim.

Head strongly but not closely punctured, with a short central groove; eyes large, deeply notched; clypeus deeply punctured, separated from the face by a row of punctures; mandibles piceous; antennæ slender, extending beyond the middle of the elytra, fulvous, the seventh and eighth joints obscure fuscous, the second joint nearly as long as the first, the third slightly shorter than the second, the others more elongate again; thorax one-half broader than long, the sides evenly rounded, the anterior angles prominent, the surface very deeply and closely punctured, the interstices slightly rugose and convex; elytra wider at the base than the thorax, with a shallow depression below the base, regularly and deeply punctate-striate, the interstices longitudinally costate, more strongly so at the sides, each elytron with a round black spot before the middle and followed below the latter by a more elongate spot; underside and legs fulvous like the upper surface, the femora with a strong tooth.

Hab. Salisbury, Mashonaland (*G. Marshall*), obtained by sweeping in a marsh and also found under bark.

Among the species with spotted elytra, the present one seems most nearly allied to *S. corrosicollis* Lefèv. on account of the strong punctuation of the thorax, but that species is described as having a rugosely punctured or corrose head and the femora armed with a very minute tooth.

SYAGRUS MASHONANUS Jac. P. Z. S. 1897, p. 544.

This species was described by me in the Society's 'Proceedings' for 1897, but I must here refer to some aberrations in regard to coloration which Mr. Marshall obtained at Natal and at Salisbury. Some of these specimens are entirely fulvous with the exception of the last five terminal joints of the antennæ, which are black as in the type; other specimens, however, are almost entirely black, with the apex of the elytra and the tibiæ pale fulvous; and a third aberration is intermediate between the two extreme forms. In all the structural characters are the same and

the femoral teeth very small. The species should, I think, be placed in a separate genus, since the thorax is not subcylindrical but dilated at the middle, and there is scarcely an ocular groove so distinct in the typical *Syagrus calcaratus*; but since so many species of this genus have been described in a very unsatisfactory manner, making the determination very doubtful, I have at present abstained from altering the nomenclature till a better opportunity presents itself.

RHEMBASTUS KRAATZI, sp. nov.

Fulvous, the head with two black spots on the vertex, terminal joints of the antennæ black; thorax subremotely punctured; elytra strongly punctate-striate, pale fulvous, narrowly margined with black.

Length 4 millim.

Head impunctate, fulvous, with a broad triangular black patch on each side above the eyes, the latter surrounded by a broad sulcus; the clypeus not separated from the face, impunctate; antennæ black, the lower six joints flavous, basal joint strongly thickened, second joint thicker and longer than the third, terminal joints thickened; thorax one-half broader than long, the sides straight, gradually narrowed towards the apex, the basal margins broadly rounded and produced at the middle, the surface distinctly but remotely punctured, fulvous; scutellum greenish æneous; elytra broader than the thorax, very convex, distinctly but not very strongly punctate-striate, each puncture surrounded by a piceous ring, the basal and extreme lateral margins narrowly greenish æneous; underside and legs fulvous, the coxæ blackish, the femora with a small tooth; prosternum with a distinctly raised lateral edge.

Hab. Cameroons (*Conrad*).

Of this species a single specimen was previously in my collection, another I received from Dr. Kraatz lately. It may be known by the two large black patches on the vertex, and the narrow greenish-black elytral margins.

RHEMBASTUS RECTICOLLIS, sp. nov.

♂. Metallic dark blue, the head, basal joints of the antennæ, the thorax, and the legs fulvous; thorax finely and remotely punctured; elytra oblong, strongly punctate-striate, the interstices sparingly punctured.

Length 4-6 millim.

Of rather elongate and subcylindrical shape, the head impunctate or with a few very minute punctures, the middle longitudinally sulcate; clypeus transversely subquadrate, impunctate, separated from the face by an obsolete groove, the apical joint of the palpi piceous; antennæ scarcely extending to the middle of the elytra, black, the lower four joints fulvous, the second joint not much shorter than the third, terminal joints elongate and slender; thorax about one-half broader than long, the sides nearly straight

and obliquely narrowed in front, posterior margin produced at the middle and rounded, the surface extremely finely and remotely punctured, the sides impunctate, the colour reddish fulvous like the head; scutellum black; elytra wider at the base than the thorax, metallic dark blue, regularly and moderately strongly punctate-striate, the interstices finely and sparingly punctured; underside bluish black; legs fulvous, the femora unarmed, the tarsi piceous, the metatarsus of the posterior legs longer than the following two joints; prosternum longer than broad, its sides sulcate, the middle narrowed, impunctate, fulvous.

Hab. Abyssinia, Arussi Galla (*Bottego*).

The shape of this species and that of the thorax is more elongate than is usually the case in this genus, but there is a great difference in the two sexes in several respects; the female is much larger, the antennæ have the first six joints fulvous instead of four, the thorax is much more transversely shaped, the tarsi are fulvous like the rest of the legs, and the metatarsus of the posterior legs is less elongate; but both specimens are undoubtedly identical and were obtained at the same place. Shape and sculpturing, as well as the unarmed femora, will distinguish the species from *R. cyanipennis* Gerst. (for which I at first mistook it); the punctate elytral interstices, the colour of the underside, and other details from *R. punctato-sulcatus* Fairm. I received two specimens from the Genoa Museum.

RHEMBASTUS VIRIDIS, sp. nov.

Dark metallic green, the terminal joints of the antennæ and the abdomen nearly black, basal joints of the former fulvous; thorax strongly and subremotely punctured; elytra deeply punctate-striate, the interstices longitudinally costate at the sides; legs greenish piceous, femora minutely toothed, tarsi dark fulvous.

Length 3-4 millim.

Head distinctly and remotely punctured, with a small central fovea; clypeus separated from the face by a distinct groove, punctured like the head; labrum and mandibles piceous; palpi flavous; antennæ black, the lower four joints flavous, basal joint piceous above, terminal joint elongate-ovate, thickened; thorax scarcely twice as broad as long, the sides straight, obliquely narrowed towards the apex, the surface strongly and rather remotely punctured, the basal margin accompanied by a row of punctures at the sides; scutellum smooth, subpentagonal; elytra slightly wider at the base than the thorax, the shoulders very prominent and smooth, strongly punctate-striate; the interstices impunctate, longitudinally costate at the sides; the costæ below the shoulders abbreviated and joined at base and apex; underside nearly black, the breast and legs with a green metallic gloss; femora with a small tooth, the posterior femora more strongly dentate.

Hab. Ashantee.

R. viridis has a somewhat similar-shaped thorax to the preceding species, and may be known, besides this character, by the metallic

green colour without any fulvous tint and by the dark underside and legs.

MENIUS CHALCEATUS, Lefèvre.

Fulvous, thorax obscure greenish piceous, subremotely punctured; elytra strongly punctate-striate, the interstices very strongly costate, an obscure elongate spot at the middle and the sides more distinctly dark greenish æneous.

Length 5 millim.

Head light fulvous, finely and sparingly punctured, the middle with a slightly raised central ridge; the eyes surrounded by a very broad sulcus; the clypeus transverse, deeply separated from the face, with a few fine punctures; antennæ two-thirds the length of the body, flavous, the seventh and the terminal three joints stained with fuscous at the apex, the second joint as long as the third, the apical joints thickened; thorax more than twice as broad as long, the sides rounded, the middle widened and broadly rounded at the basal margin, the sides with an obsolete transverse depression, the surface strongly and rather remotely punctured, the basal portion below the depression impunctate, the ground-colour dark fulvous with a dark greenish-æneous tint; scutellum pointed at the apex; elytra slightly wider at the base than the thorax, reddish fulvous, with about twelve rows of deep punctures, the subsutural one short, the interstices strongly longitudinally costate, the seventh, eighth, and ninth costæ abbreviated anteriorly and posteriorly and united at both ends; the middle of the disc with an obscure longitudinal dark greenish band, which becomes indistinct below the middle, the lateral margin likewise dark greenish and accompanied by a row of deep punctures; underside and the legs fulvous, the sides of the breast darker; the femora æneous at the middle, armed with a strong tooth, apex of the tibiæ strongly pubescent, claws bifid; the anterior margin of the thoracic episternum very strongly convex, its anterior angle joined to the margin of the thorax and produced in front of the eyes; prosternum subquadrate.

Hab. Cameroons (*Conrad*).

I have given here a detailed description of the specimen which I received from Dr. Kraatz, and which I must look upon as an aberration of Lefèvre's species, of which I possess specimens named by the author himself. My present specimen is rather larger, and has the costæ more raised and the ground-colour of a more decided fulvous; but of an elytral depression, of which Lefèvre speaks, I can see no trace, not even in the specimen named by him. The type was likewise obtained at the Cameroons.

EURYDEMUS POROSICOLLIS, sp. nov.

Fulvous, the elytra, abdomen, and the legs flavous, intermediate joints of the antennæ black; thorax foveolate-punctate; elytra ery deeply punctate-striate, the interstices slightly convex; femora with a small tooth.

Length 3 millim.

Head strongly and remotely punctured, strongly narrowed between the eyes, the latter very large, deeply notched; clypeus transverse, distinctly separated from the face, impunctate; antennæ extending beyond the middle of the elytra, the lower five and the apical two joints fulvous, the others black; thorax about one-half broader than long, the sides strongly rounded and somewhat widened behind the middle, the anterior portion deflexed, the surface rather sparingly impressed with deep foveolate punctures, more crowded at the sides, the middle with a few punctures only, the colour dark fulvous; scutellum smooth, fulvous; elytra wider at the base than the thorax, subcylindrical, flavous, the base with a distinct transverse depression, very strongly punctate-striate, the punctures round and large, the outer two or three interstices costate; below and the legs flavous, sides of the breast darker; the femora armed with a small tooth.

Hab. Cameroons (*Conrad*).

This little species, which has the typical constriction of the intraocular space, will not be difficult to recognize, on account of the colour of the antennæ and the extremely deep punctuation of the thorax, which differs in this respect from any species of the genus at present known. I received a specimen from Dr. Kraatz, another is in that gentleman's collection.

OÏDOSOMA Quedenfeldt.

I have very little doubt that this genus is identical with *Lygaria* Stål; there is nothing in the description by the author (Berlin. ent. Zeitsch. 1891, p. 172) to distinguish it from the latter genus, and the two species described are probably identical with some of those described by Weise or myself under the generic name of *Lygaria*.

CHRYSOMELA NATALENSIS Vogel.

Tsipingo (*G. Marshall*); Pine Town, Natal, Durban (my collection).

I refer specimens from the above localities to Vogel's species, but not without some doubt, since this author's descriptions are in many cases entirely inadequate for a certain recognition of the many closely allied species. The present species is one of the most convex-shaped *Chrysomelæ* I know, and almost subglobular; the thorax has rather strongly obliquely narrowed sides and its anterior margin is very deeply concave, the disc is irregularly impressed with scattered and distinct punctures, the sides being as usual more closely punctate; the elytra are deeply punctured in partly regular but mostly irregular rows, the punctures are round and of violet colour, the lateral margins are broad, slightly raised and entirely impunctate; the elytral epipleuræ are exceptionally broad, as Vogel describes them: the general colour is uniformly brownish æneous; the underside is nearly black, finely and closely punctured;

the apices of the tibiæ are clothed with thick fulvous pubescence. Vogel's description gives no particulars whatever except the mention of the smooth and broad lateral elytral margin, which some other species also possess to a smaller or greater degree, and such descriptions are worse than useless. My specimens vary in size from 6-8 millim.

CHRYSOMELA AFRICANA, sp. nov.

Below obscure dark æneous, above metallic dark green; antennæ piceous, the basal joints flavous; thorax sparingly and finely punctured at the disc, more strongly so at the sides; elytra with nine rows of very regular punctures, the interstices minutely punctured.

Length 6 millim.

Of regular ovate and convex shape, the head scarcely punctured; the antennæ piceous, the lower three joints fulvous, the terminal joints broader than long; thorax with the lateral margins nearly straight, slightly narrowed towards the apex, the anterior angles not prominent and but little produced, the anterior margin straight at the middle, the disc finely and very irregularly punctured, the punctures of unequal size, the sides with deep and larger punctures, the basal margin with a row of elongate deep punctures at the sides; scutellum impunctate, æneous; elytra very regularly convex, dark greenish, the punctures moderately large and arranged in very regular rows, distinct to the apex, the interstices with a few very minute punctures here and there, the lateral margins impunctate; underside and legs nearly black; prosternum longitudinally sulcate.

Hab. Karkloof, Natal, on thistles (*G. Marshall*).

The sculpturing of the elytra in this species differs so much in its regularity from any of those described by Vogel, that I must regard the insect as distinct; in nearly all of its allies the elytra are partly regularly, partly irregularly punctured, or the rows are geminate; the insect is also of comparative small size, and the colour of the head and thorax is more brownish æneous, that of the elytra greenish.

ATECHNA INTERRUPTOFASCIATA, sp. nov. (Plate XXII. fig. 11.)

Black, thorax finely punctured at the disc; elytra finely punctate-striate, flavous, with three transverse black bands connected with a lateral stripe, the first band curving upwards to the base, the second and third bands connected near the suture, the latter also narrowly black.

Var. Thorax fulvous, with a V-shaped piceous central mark.

Length 6-7 millim.

Head extremely minutely punctured, flat; antennæ rather feeble, black, the basal joint flavous below, terminal joints not much thickened; thorax nearly three times broader than long, the disc extremely minutely and sparingly punctured, the sides with some very deep semi-confuent punctures; scutellum smooth, greenish; elytra finely and regularly punctate-striate, flavous, with three

narrow dentate transverse black bands—the first before the middle curves upward in front of the shoulders to the base, thus including a large spot of the ground-colour, at the sides it is connected with a short longitudinal stripe which also joins the second band immediately below the middle; the third band is placed near the apex, but terminates abruptly at the sides, near its ends it is connected with the intermediate band by a longitudinal stripe which runs parallel with the suture, the latter is likewise narrowly black.

Hab. Malvern, Natal (*G. Marshall*).

I cannot identify this insect with any other species of the genus or their varieties previously described, although it is of course closely allied to several, notably to *A. 20-pustulata* Thunb.; but the pattern of the elytra is different as well as the shape of the fulvous patches which are surrounded by the black bands, and even if the latter should in some specimens be connected in the places where the short tooth-like projections seem to give indications, the pale spots would be of different shape and position than in most other species; as it is, the three specimens exactly agree except in the colour of the thorax. The most characteristic distinction of the species will be found in the laterally interrupted third band of the elytra and its connection with the preceding band by a longitudinal short stripe near the suture. *P. pardalina* Fab. is a somewhat closely allied species which has the flavous elytral margin in common with the present insect, but the position, number, and shape of the flavous markings are quite different.

EXPLANATION OF PLATE XXII.

- Fig. 1. *Pecilomorpha hirsuta*, p. 216.
2. *Lema cyaneoplagiata*, p. 214.
3. *Cryptocephalus epipleuralis*, p. 223.
4. *Acolastus nigroplagiatus*, p. 224.
5. *Melitonoma marshalli*, p. 216.
6. *Anisognatha quadriplagiata*, p. 220.
7. *Miopristis pusilla*, p. 220.
8. *Ætheomorpha cærulea*, p. 221.
9. *Gynandrophthalma nitidicollis*, p. 219.
10. *Cheiridisia inornata*, p. 226.
11. *Atechna interruptofasciata*, p. 241.
12. *Pseudocolaspis costata*, p. 230.

4. On a new Flagellate Protozoon of the Genus *Lophomonas*.

By E. H. J. SCHUSTER, F.Z.S.

[Received January 31, 1898.]

In the year 1860 Stein established the genus *Lophomonas* for the reception of a Flagellate Protozoon observed by him inhabiting the intestinal canal of *Blatta orientalis*, to which he gave the name *Lophomonas blattarum*. The same species was observed shortly afterwards by O. Butschli under similar conditions. The

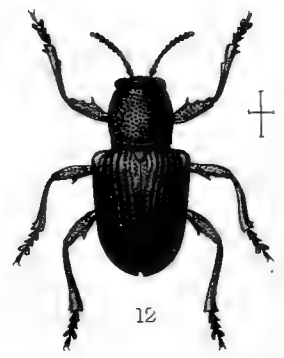
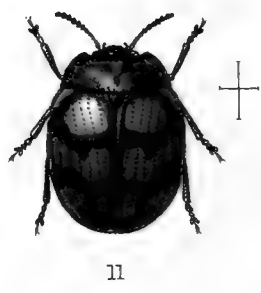
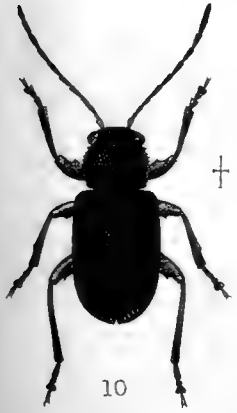
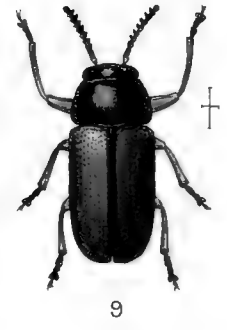
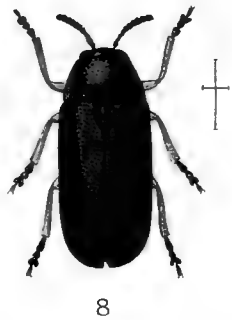
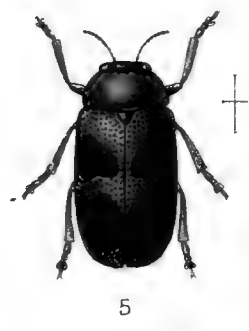
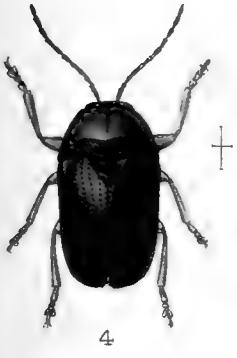
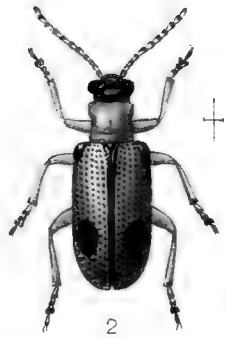

W. Purkiss del. et lith.

West, Newman imp.



latter also described another species with the same habitat, under the name *L. striata*.

Mr. Saville Kent, who established the family Lophomonadidæ to receive this genus, in the 'Manual of the Infusoria,' gives the following diagnosis, viz. :—

“The genus LOPHOMONAS Stein.

“Animalcules free-swimming; somewhat plastic and variable in form, spheroidal, ovate or fusiform, bearing at the anterior extremity a crescent-shaped fascicle of long slender flagellæ; endoplast sometimes distinct; contractile vesicle not yet recognized; inhabiting the intestinal canal of various Insecta.”

On examining the contents of the intestine of *Blatta americana* I observed a form which, although it possessed all the generic characteristics above cited, differs very markedly from either of the two species hitherto described, and which I propose to designate by the name *Lophomonas sulcata* (fig. 1).

Fig. 1.

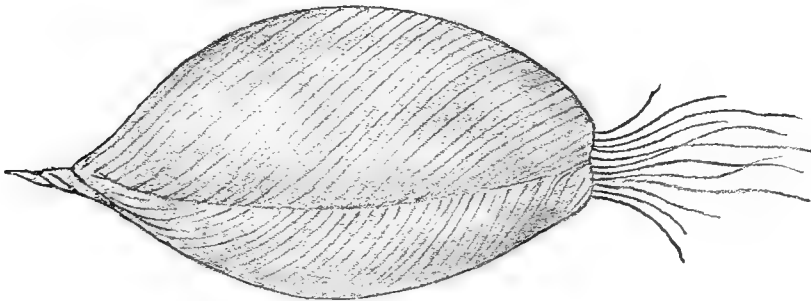

Lophomonas sulcata, ×800.

LOPHOMONAS SULCATA, sp. n.

This Protozoon is of comparatively large size, being about 60 or 70 μ or $\frac{1}{300}$ inch in length; whereas *L. blattarum* is $\frac{1}{825}$ in length, and *L. striata* $\frac{1}{800}$. The body is subfusiform in shape, with the anterior extremity truncate and bearing the fascicle of the flagella, and the posterior extremity bearing a tail-like projection, exceedingly variable in length (in some cases this projection is almost entirely absent, in others it was fully half the length of the body). The body is divided by a deep sulcus into two lobes, and the whole surface is covered by well-marked oblique striæ; the internal protoplasm is hyaline: no endoplast (after treatment with osmic acid and picro-carmin) or contractile vesicle was observed.

Although I have watched several living specimens, I have never seen a solid particle of food-matter ingested, and therefore consider it probable that the animal obtains nourishment by the absorption of dissolved proteids, &c., over the entire surface of the body. These Protozoa were present in only one part of the alimentary canal, namely, in the upper part of the colon.

In some cases *Nyctotherus ovalis* Leidy, and almost always *Lophomonas blattarum* Stein, accompanied it, but neither of these species was at any time taken in any other part of the alimentary canal. This perhaps is due to the salivary excretion exercising a poisonous influence on these animals. This view was suggested by one of the observations of Professor Grassi and Dr. Sandias on the Termites, an account of which appeared in the 'Atti dell' Accademia Gioenia di Scienze Naturali in Catania,' 1893-4, and was translated by Mr. W. F. H. Blandford in 1897, in the 'Quarterly Journal of Microscopic Science.' Among the Termites under particular circumstances certain individuals are fed on the secretion of the salivary glands of others, and under such conditions these individuals, although normally rich in parasitic forms, have been observed to contain none whatever.

Another fact worthy of note is that although the immature forms of *Blatta americana* contain a large number of infusorial parasites, in the adults few, if any, are present. I examined the contents of the rectum and the dejecta of *Blatta americana*, and found two forms of cysts present; one of these I think was the

Fig. 2.

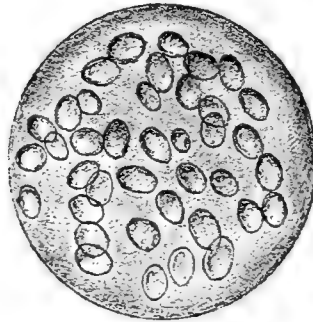
Possible cyst of *Lophomonas sulcata*?, $\times 800$.

cyst of *Gregarina blattarum*. The other (fig. 2) was small and spherical, and contained numerous oval spores. The latter may be the cyst of *Lophomonas sulcata*.

April 5th, 1898.

Lt.-Col. H. H. GODWIN-AUSTEN, F.R.S., Vice-President,
in the Chair.

The Secretary read the following report on the additions to the Society's Menagerie during the month of March 1898:—

The registered additions to the Society's Menagerie during the month of March 1898 were 102 in number. Of these 22 were acquired by presentation, 50 by purchase, 1 was born in the Gardens, 8 were received by exchange, and 21 on deposit. The total number of departures during the same period, by death and removals, was 79.

Among these may be specially noticed:—

An example of the Galapagan Tortoise (*Testudo galapagensis*), one of the Giant Tortoises of the Galapagan Islands, deposited by the Hon. Walter Rothschild, F.Z.S., on March 27th. This Tortoise is believed to be about 130 years old, and is said to weigh about 8½ cwt.

Mr. Oldfield Thomas exhibited a series of specimens of a Siamese Squirrel provisionally assigned to *Sciurus finlayson* Horsf., which had been obtained at Ayuthia, Siam, by Mr. Stanley S. Flower, to illustrate the remarkable variability to which this species was subject. The specimens had all been shot in one grove of trees a few miles north of Ayuthia on Feb. 5, 6, and 7, so that the factors of local and seasonal variation were entirely excluded, and these Squirrels were thus most valuable material for the study of individual variation in colour.

After eliminating duplicate specimens, the following seven forms could be distinguished:—

1. Head and back dark grizzled, more or less tinged with rufous. Ears, feet, and belly red. Tail grizzled black and yellowish.

2. Like no. 1, but the muzzle partly white, and the tail broadly washed with rich red.

3. Crown and back still dark grizzled rufous, but muzzle, ears, hands, feet, and whole of belly white, as they were in all the succeeding specimens. Tail as in no. 1.

4. Like no. 3, but tail above grizzled blackish washed with red (as in no. 2), beneath white (as in no. 7).

5. Crown and back grizzled whitish-grey, the rufous tone quite gone. Tail grizzled, washed with buffy instead of rufous.

6 & 7. Like no. 5, but the tail in the first grizzled, washed with white, and in the second quite white.

Finally, the type of *S. finlaysoni* was wholly white, while at the other end of the series forms such as "*S. ferrugineus*" and "*S. splendidus*" were rich red throughout.

At first sight it might be supposed that it would be hopeless to

look for any explanation of these colour-variations, and that their wonderful differences rendered useless any study of them for systematic purposes. But further consideration seemed to show that all the variations, diverse as they were, might be explained by the combined influences of albinism, melanism, erythrism, and xanthism on a naturally variable species. In the present series melanism did not occur, as it did in some of the other described forms; but a greater or less degree of albinism might easily be responsible for the whitening of the muzzles, ears, feet, bellies, tails, and ultimately of the whole animal, and erythrism for the different degrees of red present on different specimens. Finally, xanthism, of which the best known instance was the common buff-coloured variety of the Mole, might be responsible for the buffy washing on the tail of specimen no. 5 described above.

If this explanation were correct, we should, after the elimination of the affected specimens, be able to look upon example no. 1 as the normal primitive form the colour of which might be accepted for comparison with that of allied species, just as if *S. finlaysoni* were no more variable than other Squirrels. A similar sort of elimination had to be practised in studying European Squirrels, among which the many individuals affected with melanism had to be withdrawn from consideration before any satisfactory study could be made of the local coloration.

Erythrism in Mammals, and especially in Squirrels¹, had often been observed before, while in combination with albinism it had been found to present an explanation of the remarkable colour-phenomena occurring in the Spotted Cuscus (*Phalanger maculatus*)².

The following papers were read:—

1. On the Species of the Genus *Millepora*: a preliminary Communication. By SYDNEY J. HICKSON, M.A., D.Sc., F.R.S., F.Z.S.

[Received April 5, 1898.]

The phylum Cœlentera presents us with many families and orders of animals in which our knowledge of the characters which can be satisfactorily used for the purpose of systematic classification is singularly deficient. In the Madreporaria, the Gorgonacea, and the Milleporidæ the form of growth of the colony, the colour, and the structure of the hard skeletal parts are the only characters which have been used for the diagnosis of genera and species. In many cases it is probable that the diagnosis afforded by these characters should be considered to be satisfactory, but as the number of specimens in our museums

¹ Cf. P. Z. S. 1886, p. 77.

² Cat. Marsup. B. M. p. 199 (1888).

increases it becomes more evident that in others no satisfactory classification can be framed until we have a thorough knowledge of the anatomy of the polyps which construct these skeletons and of the canal-systems which bind them together into colonies.

In some genera of Madreporaria, for example, of which the skeletal characters only are known, a long series of intermediate stages can be found between the type specimens of the different species, and every new collection of specimens that is examined increases the difficulty of deciding whether a particular intermediate form belongs properly to one species or another. Moreover, in this same group the outlying species of one genus resemble the outlying species of another so closely that it is often a matter of great difficulty to determine, on our present system, to what genus a particular specimen belongs.

Nearly every important systematic work on these Cœlenterates contains some remarks about the difficulty of determining species, and examples are quoted of series of intermediate forms connecting closely allied species. If it were possible to frame some general rule for the correct definition of a species, which would be agreed to by all systematic zoologists, our task might be less difficult than it is; but, as matters stand, the conception of what is a species of one worker is so different from that of another that there is constantly going on a see-saw of construction and destruction of new species in our systematic literature.

I do not propose to attempt to define the conception "species" in Cœlenterates, but I think that all zoologists would agree that, if a form which is known as species A were proved to give rise to an embryo which grew into a form which had hitherto been known as species B, the two forms would have to be merged into one species with one specific name. Similarly, I imagine that all zoologists would agree that if a coral known as species X changed in the course of its life-history into a form known as species Y, then the forms X and Y should be regarded as one species and retain only one name. In the absence of any experimental proof that the embryo of one so-called species of coral gives rise, under any circumstances, to another so-called species, or that one so-called species changes in the course of its life-history into another, it is necessary to examine with very great care the anatomy of the soft parts as well as the skeletal structures, in order to determine whether it is possible or even probable that such changes actually occur in nature. If we find, then, that the polyps or reproductive organs of a coral with one form of growth are essentially different from those of another form, we may consider there is good reason for believing that such changes do not occur and the species founded on the skeletons are good; but if, on the other hand, the polyps, reproductive organs, and other characters of the two forms are essentially the same, then there is reason for believing that the species founded on skeletal characters may not be good.

Before proceeding further with this discussion of the characters

which may be used for distinguishing species in Cœlenterates, it may be well to describe briefly the general results of my observations on the genus *Millepora*. This genus stands quite by itself among living corals. No one genus of the other Hydrocorallines can be confused with it, both the living tissues and the hard skeletal parts being perfectly distinct. It is widely distributed through the tropical seas, occurring in the Red Sea, Indian Ocean, Malay Archipelago, Tropical Australian waters, Pacific Ocean, and in the seas of the West Indies. It is essentially a shallow-water genus, living in abundance in most of the coral-reefs, and not occurring in greater depths than 15 fathoms.

The form varies immensely. It may be broadly lamellate or densely branched, or anastomosing, or it may form thin incrusting plates on dead corals. In all large collections of Millepores series of intermediate forms may be found between all the most prominent types.

The difficulty of defining and describing the species of this genus has been commented upon by several authors. Dana, for example, says "There is much difficulty in characterizing the Millepores on account of the variations of form a species undergoes and the absence of any good distinctions in the cells. The branched species are often lamellate at the base, owing to the coalescence of the branches, and the lamellate species as well as the branched sometimes occur as simple incrustations." My own investigations confirm and amplify Dana's statements on this point.

Notwithstanding these difficulties a large number of species of the genus have been described. In the writings of the older naturalists many species were described which have since been relegated to other classes of the animal kingdom, and in palæontological literature we find many species of fossil corals referred to the genus on erroneous or very unsatisfactory grounds.

Apart from all these, which may be left out of consideration in this paper, no less than 39 species of the genus *Millepora* have been described.

The characters which have been used for determining these species are:—(1) The form of the corallum. (2) The size of the pores. (3) The degree of isolation of the cycles. (4) The presence or absence of ampullæ. (5) The texture of the surface of the corallum.

(1) *The Form of the Corallum.*—This feature is even more unsatisfactory than I anticipated at the beginning of my investigation. In the first place, attention has been called by Dana, Duchassaing and Michelotti, and others to the fact that *Millepora* grows in an incrusting manner on many objects, and thereby assumes the form of the object on which it grows. It is quite easy to distinguish such forms as incrusting forms when they have only partially covered such objects as the horny axis of a *Gorgonia*, a glass bottle, or an anchor; but in many cases the object is so completely overgrown by Millepore and other marine

zoophytes that its presence is not discovered until a fracture is made. To give only one example to illustrate this point:—A specimen in the Manchester Museum was named *Millepora intricata*, and, on comparing it with the description of the species, I thought at first that the name was correct. On breaking it into two pieces, however, I found that the form it had assumed was due to the fact that it had grown over a small piece of wood.

In a still greater number of cases, however, the Millepores grow upon the dead coralla of other Millepores or Madreporas or other white corals, and then the difficulty of determining whether the form of the specimen is due primarily to the living coral or to the one on which it has grown becomes extreme. There is a large specimen in the collection brought home from New Britain by Dr. Willey, of very irregular form, one part of which has a form like that attributed to the species *M. plicata*, another part to the species *M. verrucosa*, but a broken knob shows quite clearly that a part of this great mass has grown over a dead coral. It would consequently be quite impossible to determine with any degree of satisfaction to which of the already-described species it belongs, unless every knob and projection were broken off to see whether the dead coral extends as a basis through the whole piece.

In the second place, the immense amount of variation in form which occurs in large specimens of *Millepora*, and, indeed, in many small specimens too, leads to very great difficulties in the determination of species which have been described on form as the principal character. In Dr. Willey's collection there is a series of varieties of growth leading from a massive lamellate form to a complicated branching and anastomosing form.

A careful study of these skeletons, then, points very definitely to the conclusion that the general form of the corallum of *Millepora* should be used, not as a primary, but as a very subsidiary character in the description of species.

The form assumed by the corallum must depend upon many circumstances connected with the exact spot on which it grows. If a *Millepora* embryo happens to become fixed on a large piece of dead coral, it will form a large incrusting base, and such a base nearly always gives rise to a lamellate form of growth; if, on the other hand, the embryo settles on a small stone or other object, lamellate growth is impossible, and the corallum will be ramified.

The growth of the corallum must also be influenced by the propinquity of other corals. Its form must be adapted to the space left between its neighbours on the crowded reef. Again, its form must be modified by the depth of the water in which the embryo happens to develop. As Duchassaing and Michelotti pointed out long ago, *Millepora* often grows in very shallow water and is consequently unable to develop in height. Specimens that happen to fix themselves on foreign bodies on the edge of the reef at a depth of 5 or 6 fathoms can and do grow to a very great length without impediment.

It is also extremely probable that the available food-supply, the

particular set of the tides and currents, and the chemical composition of the sea-water, particularly as regards the amount of calcium carbonate it holds in solution, vary very considerably in different reefs and in different parts of the same reef. Such variations must affect the rate of growth of Millepores, and I think it is reasonable to believe the mode of growth also.

(2) *The Size of the Pores.*—Dana, Milne-Edwards and Haime, and Quelch have used the size of the pores as a specific character, but, with one exception to be referred to presently, they give no measurements, being contented to use the expressions “very small,” “large,” “minute,” &c. Unless the zoologist has an immense number of specimens from different localities to compare one with another, it is difficult for him to understand what is meant by such expressions; but even the naturalists of the great national collections would be mystified by the case of *M. alicornis*, whose gastropores are according to Quelch very large, and according to Milne-Edwards and Haime “très petits.” I have measured a very large number of gastropores, taking for each specimen an average of 6 or 12.

The greatest average diameter of the gastropores I have found is 0·37 mm., the smallest is 0·13 mm., so that the difference between those pores which might legitimately be called “very large” and those that are “very small” is 0·24 mm. But these “large” pores are very rarely seen; the great majority of the gastropores are between 0·3 mm. and 0·2 mm. This general result agrees fairly well with the only measurement I have been able to find in the literature of the subject, namely that of *M. murrayi* by Quelch, which is given as 0·25 mm.

The question that had next to be considered was whether there is any other feature constantly associated with large pores and with small pores. The large pores are very constantly found in specimens with thick lamellæ or branches, while the small pores are found on those of a more slender habit.

A further investigation of the question yielded an explanation of the variation in the size of the gastropores, which proves that it cannot be of any real service for specific distinction.

I found that in the gastropores of specimens of slender growth there are only 3 or 4 tabulæ, while in those of more massive growth there may be as many as 9 or 10 tabulæ. This suggested that the size of the gastropores depends upon the age of the gastrozoid which lived in it, and, on measuring carefully a number of gastropores from the base, middle branches, and growing-points of a specimen in the Manchester Museum labelled *M. complanata*, I found that the average diameter of the gastropores at the base, which we may assume in this case to be the oldest part, was 0·185 mm., on a middle branch 0·17 mm., and at the growing-edge, *i. e.* the youngest part, it is only 0·13 mm. This general result was confirmed by similar series of measurements on other specimens. I also found that the greatest average diameter of

gastropores which I have given above was obtained from the base of a massive specimen, while the smallest was obtained from a growing-edge of a slender specimen.

Moreover, it occurred to me that if the size of the gastropores is dependent upon their age or the rate at which the gastrozooids have grown, there ought to be, in some cases at any rate, a difference between the average size of the gastropores on one side of a branch or plate and that on the other; those on the face most favourable as regards food-supply in the living state should be larger than those on the other. Measurements confirmed my point, and I found a difference in two out of three specimens between the gastropores on one side and those on the other as great as 0.03 mm.

(3) *The Degree of Isolation of the Cycles.*—Moseley noticed that in one specimen of Millepore taken at Zamboanga the cycles were much more distinct than in other specimens, and suggested that this feature might be of specific value. After very careful consideration I am convinced that it cannot be. In many large specimens it will be seen that the cycles are much more distinct in one part than another. Sometimes the cycles are so crowded as to be indistinct at the edge, and perfectly clear on the face or at the base. The evidence points to the conclusion that in slow-growing Millepores in unfavourable situations the cycles are distinct, and that in fast-growing specimens in good situations the polyps are formed in such great numbers that the cycles become confused.

(4) *The Presence or Absence of Ampullæ.*—The ampullæ of *Millepora* were discovered by Quelch in a specimen obtained by the 'Challenger.' He founded a new species for the specimen, which he called *M. murrayi*, and used this feature as an important specific character.

I have found that ampullæ occur in plicate, ramose, and digitate specimens, and, as will be explained later, the absence of ampullæ in any particular specimen merely means that at the time it was taken it was not in a state of sexual activity.

It is greatly surprising how very rarely specimens are found in this particular condition, but I believe that it must occur in all varieties at one time or another in their life-history.

(5) *The Texture of the Surface of the Corallum.*—The species *M. verrucosa* of Milne-Edwards, *M. tuberculata* of Duchassaing, and *M. striata* of Duchassaing and Michelotti have been named after the peculiarities of their surface.

I have had an opportunity of examining a very fine specimen of a Millepore, resembling very closely the type of *M. verrucosa*, and I found that on the summit of a very large number of the verrucæ there is a small hole of the shape of a keyhole, which leads into a cavity formed by a parasitic cirripede (probably *Pyrgoma milleporæ*). On others, however, no such evidence of parasitic interference with normal growth is apparent from the surface, but nevertheless there is reason for believing that the tubercle may have been due

to hypertrophy of the Millepore at a spot which was irritated by some parasite, the parasite subsequently being overwhelmed or killed.

Now it is not cirripedes alone which attack Millepores; various algae, worms, crabs, and other creatures settle on the Millepores and cause profound modifications of their growth.

I think there is very good reason for believing that the warts, tubercles, ridges, and the like which occur on the surface of these corals are primarily due to parasites or to some other irritant, and that it is very doubtful whether they are ever of specific value. If they are to be used, however, it will be found that they lead to many difficulties, as it is not infrequently the case that one side of a lamella is tuberculate and the other is not, or that one lamella or branch is covered with wart-like processes and the others are smooth.

(6) *The Relative Number of Dactylopores and Gastropores.*—Finding that all other characters derived from the skeleton are unsatisfactory for determining and distinguishing species, I thought it possible that a good character might be found by calculating the average number of dactylopores to each gastropore in a number of species.

In many specimens the cycles are so close one to another that it is often difficult to determine to which cycle a particular dactylo-pore belongs. In order, therefore, not to be misled, I used only those cycles which were clearly defined from their neighbours.

In the following table I have put together the results of my calculations on this point:—

Accepted specific names of specimens. (The name of donor and locality in parentheses.)	Number of cycles counted.	Average No. of dactylopores in each cycle.	Highest number.	Lowest number.
I. <i>M. murrayi</i> . (Haddon, Torres Str.)	6	5·15	8	5
II. <i>M. alcornis</i> . (Brit. Mus., W. Indies.)	8	6·45	8	5
III. <i>M. alcornis</i> . (Shiple, Bermudas.)	6	5·6	7	5
IV. <i>M. alcornis</i> . (Lister, Tonga.)	12	6·7	8	6
V. <i>M. plicata</i> . (Hickson, Celebes.)	12	7·08	9	6
VI. <i>M. complanata</i> . (Man. Mus., W. Indies.)	7 100	6·28 5·82	7 7	5 4
VII. <i>M. alcornis</i> . (Man. Mus., W. I.)	7	6·14	7	5
VIII. <i>M. alcornis</i> . (Agassiz, Bahamas.)	13	5·5	9	4

It will be seen from these figures that there is not much variation in the average proportion of dactylopores to gastropores in the different forms examined. The largest number of cycles I was able to count on one colony gave an average of a trifle under 6. It is noteworthy that this is the exact mean of the highest and lowest averages obtained from smaller specimens on which only a few cycles could be counted.

The extreme averages 5·08 and 7·08 (IV. & V.) do not show so great a range as may be seen on different parts of a single piece 9 and 4, and 8 and 3.

On the basal incrusting regions of a specimen of Millepore in the Manchester Museum I have observed several widely-separated gastropores attended by only one, two, or three dactylopores, and a similar paucity of dactylopores I have more recently noticed in specimens from the collection made by Mr. Gardiner in Funafuti and Rotuma.

I may point to the figures obtained from an examination of the specimens of *M. alicornis* given to me by Mr. Lister to show the variability of this feature in the colony.

The specimens were a number of broken branches, each a few inches in length, beautifully preserved in spirit. Two specimens were taken at random and twelve cycles counted on each. The average of one came out 6·7 dactylozooids to each gastrozooid, and of the other 5·08 dactylozooids to each gastrozooid.

The only author who has referred to the number of dactylopores in each cycle is Moseley. He says that each group consists "of a centrally placed gastropore surrounded by a ring of five, six, or seven dactylopores," and on counting the number of dactylopores in each cycle that are drawn in Mr. Wild's picture in Moseley's 'Philosophical Transactions' paper I find that the average is 6.

In Milne-Edwards and Haime's figure of *M. intricata* there are 5 gastropores to 35 dactylopores; of *M. verrucosa*, there are 7 gastropores to 32 dactylopores (?); in *M. tuberculosa*, 5 gastropores to 18 dactylopores; but it is not certain that these figures can be absolutely relied upon. They are, however, on the whole, very similar to my own results.

The general conclusions, then, that must be drawn from these observations are:—

That the number of dactylopores in each group is very variable in each individual colony of *Millepore*. There may be, in fact, any number up to 8 or 9.

That specimens of widely different forms of growth have approximately the same average number of dactylopores in each group.

That the average number of dactylopores in each group for specimens of all kinds is about 6.

That the average number of dactylopores to each gastropore cannot be used as a specific character.

Anatomy of the Soft Parts.—I have examined the anatomy of the soft parts of a large number of specimens preserved in alcohol by

mounting them whole and by making series of vertical sections. The following is a list of the specimens examined :—

<i>Form of growth.</i>	<i>Donor.</i>	<i>Locality.</i>
Digitate & palmate.	Prof Haddon.	Torres Strait.
“Alcicornis.”	Mr. Shipley.	Bermuda.
“Alcicornis.”	Mr. Lister.	Tonga.
“Alcicornis.”	Prof. Agassiz.	Bahamas.
“Alcicornis.”	British Museum.	W. Indies.
Ramose.	Mr. Gardiner.	Funafuti.
Plicate.	”	”
Foliate.	”	”
Striate.	”	Rotuma.
Ramose.	Dr. Willey.	New Britain group.
Plicate.	”	”
(Several small fragments).	”	”
Complanate.	Mr. Duerden.	Jamaica.
“Exaesa.”	Dr. von Marenzeller.	Red Sea.
“Dichotoma.”	”	”
And a specimen of “Plicate” form obtained by myself in Celebes.		

The preparation and examination of these Millepores has extended over a period of twelve years, with the result that I have failed to find any constant difference between them that can be used for the separation of the genus into species.

The structure of the gastrozooids and the dactylozooids is essentially the same in all the specimens examined, but the size varies somewhat, according to the position from which the preparations are made—those at the growing-edges being smaller than those at the base, &c. The canal-system is the same in all specimens. Zooxanthellæ of exactly the same size are always present in the superficial canals. I have observed the two different kinds of nematocysts, the large and small figured by Moseley, in all my preparations. Many of the Millepores are known to sting badly, and have received popular names in various languages expressive of this feature, but Mr. Gardiner informs me that one form in Funafuti did not sting. “It was at its base rather overgrown by weed, and above, curiously enough, it did not sting, and was the only one in Funafuti that did not.”¹

It is not known whether both the large and the small nematocysts possess the stinging-power, or whether it is confined to only one kind. The small nematocysts are confined to the tentacles of the gastrozooids and dactylozooids, and the large nematocysts, when ripe, occur in the superficial cœnosarc between the pores, but are specially crowded in the neighbourhood of the gastropores. Moseley’s description of these features in *Millepora* is correct for all specimens I have examined. The size and the position of

¹ Extract from a private letter.

the small nematocysts render them difficult to measure, but the large nematocysts can be scraped off the surface of any preserved specimen in considerable numbers. The average size of these nematocysts when ripe in specimens from Celebes, Bermuda, Bahamas, Funafuti, Rotuna, the Red Sea, Jamaica, and New Britain is exactly the same—0.02 mm. \times 0.025 mm. The number of the nematocysts varies considerably, but as this must be influenced by the manner in which the specimens were killed, and by external conditions affecting them before they were killed, no differences of specific value can be framed from this feature.

The general anatomy of all these forms is in other respects, as well as those mentioned, so much alike that I know of no means of distinguishing one series of sections of well-preserved material from another. There are no features of the soft parts which indicate in the least the general character of the form and structure of the skeleton they secreted.

By far the most interesting and in many respects the most important structures of these corals are the generative organs, and to them we should naturally turn for characters which might assist in distinguishing species. Unfortunately, however, our knowledge of these structures is very meagre and does not at present help us very much.

In the specimen presented to me by Prof. Haddon from Torres Strait, I discovered that the male sexual cells migrate into dactylozooids which become converted into medusæ. These medusæ, when ready to become free, are situated in ampullæ, which are approximately 0.4 mm. in their greatest diameter: that is, in holes in the skeleton larger than the largest gastropores. In another specimen of a different mode of growth presented to me by Mr. Gardiner from Funafuti I found numbers of these medusæ in ampullæ of exactly the same size. The medusæ of these two forms are quite indistinguishable one from another. It seems probable, then, that the Millepores from Zamboanga (Quelch), Jamaica, and several others from unknown localities in which ampullæ of this character have been described bore in the living state medusæ. No gaps similar to these can be seen in any of the preserved specimens which have been examined except those which contain or have contained medusæ. The fact that the largest ampullæ of all specimens are of approximately the same size, coupled with the fact that the medusæ of such different forms as those given me by Mr. Gardiner and Prof. Haddon are exactly similar, suggests that the medusæ of all Millepores are similar. At any rate, there is no evidence at present that there is any difference between the medusæ of the different forms.

It is a very extraordinary fact that the ampullæ are so rarely found. I have had the opportunity of examining carefully a very large collection of Millepores collected in the West Indies, and deposited in the Liverpool Museum. I failed to find a single ampulla in any one of them, but a small skeleton sent to me by Mr. Duerden from Jamaica exhibited an immense number of them.

In the large collection at the British Museum only a few specimens exhibit ampullæ.

It seems to be certain, then, that the medusæ are but rarely formed, but when they are they are formed in very great numbers.

General Considerations.—It appears to me that these investigations present very strong reasons for believing that there is only one species of *Millepora*. That one species must, on the ground of priority, be called *Millepora alvicornis*.

There are two courses open to us: either to assume that there are characters still undiscovered which distinguish one species from another, and on the strength of that assumption retain the old specific names; or to wait until such assumed characters are discovered before recognizing more than one species.

Of these two courses the latter appears to me to be preferable. If we consider a series of specimens, *a*, *b*, *c*, *d*, &c., are distinct species, we assume that the embryo of *a* gives rise to a definite form of coral, so like its parent *a* that it can be easily distinguished from the forms *b*, *c*, *d*, &c. If, on the other hand, we consider them as modifications in the form of one species, then we may consider it possible that under different external conditions the embryo of *a* may give rise to a form similar to *b*, or *c*, or *d*, or any intermediate or combined form of these varieties.

By the former course we are practically denying the possibility of considerable plasticity; by the latter course, while not assuming that it exists, we do not deny it.

Now the evidence in favour of the view that the Millepores are extremely plastic in their growth increases with every new collection that is examined. Nearly every large specimen shows some branch or plate that is distorted, twisted, compressed, or bent into a different shape from the rest of the coral; its surface shows galls, cups, tubes, warts for the accommodation of crabs, worms, cirripedes, algæ, and other so-called parasites. Nor is there any greater constancy of form in the smallest independent specimens that can be found. They may be simply incrusting, or may form a simple crest, or a short pointed process from the base, according to the character of the object on which they grow. It is therefore, in my opinion, not only extremely inconvenient but positively erroneous to consider those forms of growth that may be grouped round one "type" as a species distinct from those that can be grouped round another "type." By this plan we either deny the extreme degree of variability which there is reason to believe does occur in nature, or else we employ specific names in a sense altogether different from that in which they are used in the other groups of animals and plants.

It would be premature to propose to extend my remarks to other genera of corals, but I have already pointed out that there are some reasons for believing that there is not more than one species in the Alcyonarian genus *Tubipora* and the Hydrocoralline *Distichopora*. Our knowledge of the soft parts of *Madrepora* and other genera of Zoantharian corals is so small that it is possible that in

the future a very considerable reduction in the species of this genus will also be necessary. *Madrepora* itself is a genus with a very wide geographical distribution in shallow tropical waters, like *Millepora*. Its coralla are also subject to extraordinary variability in their form of growth, and the species have been founded on skeletal characters only. All the species, or many of them, may be good, but the classification of the genus must be considered to be unsatisfactory until our knowledge of the anatomy of the polyps of the different varieties has been considerably extended.

2. On the Perforate Corals collected by the Author in the South Pacific. By J. STANLEY GARDINER, M.A., Gonville and Caius College, Cambridge.

[Received January 31, 1898.]

(Plates XXIII. & XXIV.)

Of the Perforate Corals obtained by me in the South Pacific I have been able to refer specimens to fifty-one species; of these fifteen seem to me to be new. Three of these have already been described by Mr. Bernard in the British Museum Catalogue, and the characters of twelve are now given. I have so far as possible compared my specimens with those in the British Museum, and, although I have referred back to the original descriptions in nearly all cases, I give, for those genera of which the Museum has published a catalogue, simply one reference, namely to that catalogue, by placing the number of the species in it after the name in parentheses.

I am much indebted to Mr. Bernard for his assistance in comparing the *Astræopora* and *Turbinaria*, and for writing the description of *Montipora columnaris*. Prof. Jeffrey Bell, too, has kindly placed at my disposal every facility which the British Museum affords.

I. Genus MADREPORA.

Madrepora Linnæus, Syst. Nat. ed. x. p. 793; Duncan, Rev. Madrep. p. 183.

The specimens of this genus in the collection are generally rather small, most of them having been obtained by diving or dredging. I have been able to refer specimens to 25 species, and in addition I have described 3 which I consider new. From Funafuti there are also fragments of two species from 30 fathoms, two from 20 f., and five from 6-8 f.: of these, four species seem to be new, but they are too small to attempt to describe. There are, too, a number of young colonies unidentified.

Generally, on the reefs of Rotuma and Funafuti I found that, although certain species are locally very common, there is little

¹ Communicated by W. BATESON, F.R.S., F.Z.S.

variety; on shoals a few fathoms submerged, the latter is often very considerable, one shoal off Oinafa, Rotuma, with 2-4 fathoms of water, giving seven species, while I have been able to identify only four from the reefs and boat-channel of that island. From Funafuti, three species are recorded from 35 fathoms and one from 30 fathoms.

1. *MADREPORA CRATERIFORMIS*, n. sp. (Plate XXIII. fig. 1.)

The corallum is in the form of an oval-shaped cup 8 by 10 cm. in diameter, and about 1.5 cm. deep, with one subcentral stem on the underside; its edge is about 3 mm. thick, and formed by a mass of budding corallites. The epitheca is very evenly continued underneath to the edge of the cup and shows a number of concentric lines of growth. The inner part of the cup is crowded with small, very even-sized corallites; these in places may form short lines of rather more prominent corallites, but there is no greater approximation towards the typical axial corallite of the *Madrepora* than there is in many of the *Turbinaria*. The corallites are tubular, 2-3 mm. in length by about 1 mm. in diameter, and somewhat appressed to the walls of the cup; the upper openings of the calices are .4-.5 mm. in diameter, and there are usually 7 in 1 cm. Generally neither septa nor columella can be distinguished, but there are often some larger spines at the edge of the calice, which indicate their position. The walls of the corallites are covered with relatively long, rough, flattened, blunt spines, which in places give rise to irregular striations. The cœnenchyma is a rather coarse reticulum, covered with similar spines; it is well developed at the edges of the cup, but completely hidden by the tubular corallites within.

Funafuti; lagoon shoal.

There is only one specimen, which may be the young form of some previously described species, but it does not appear like the incrusting base of a colony, nor do its corallites correspond to the descriptions of those of any of the species described in the British Museum Catalogue. The colony, if it is, as I believe, adult, shows an approach to the *Turbinaria*, but, if young, indicates a stage not far from that from which the *Turbinaria* and the *Madrepora* diverged in their development.

2. *MADREPORA SECUNDA*, Dana (2).

The specimen, which is about 13 cm. high, very closely resembles Dana's description. The branches are, however, more crowded and grow almost vertically. The primary septa are distinct, the directives being more prominent.

Funafuti; outer reef.

3. *MADREPORA ROTUMANA* n. sp. (Plate XXIII. fig. 2.)

Corallum massive, of broad plates, formed by the fusion of branches radiating from a short and stout pedicle. Two to four plates thus formed generally arise from the pedicle and radiate

out at right angles to it, being often 20-30 cm. long by about 10 cm. broad at the base and the corallum 3 cm. thick; the end twigs are incompletely fused. On the upper surface are a number of conical elevations, really formed by the end twigs having turned upwards and having budded out fresh twigs at their bases; they vary largely according to position, but are seldom more than 3 cm. high by 1.5-3 cm. broad at the base. The axial corallites are 2.5-3 mm. in diameter, and are seldom more than 1 mm. exsert; the opening of the calice is about 1 mm. broad. The sides of the cones and the upper surface of the corallum are covered by nariform or tubi-nariform corallites about 1.5 mm. in diameter by 2-3 mm. in length; they are generally about 3 mm. apart, and the intervals between are occupied by small immersed or subimmersed corallites. The primary and secondary septa are generally distinct in the axial corallites, the directives nearly meeting in the middle line, the secondary much narrower and thinner; generally in the radial corallites six very narrow thick septa can be distinguished. The under surface of the corallum is covered with round immersed corallites about 1 mm. in diameter and 1-3 mm. apart; the primary septa are distinct, the directives more prominent. The corallum is formed by very coarsely reticular elements, covered on the upper surface by low granular spines, which may form striations; the under surface of the plates seems to be thickened by a true cœnenchymatous formation, showing very clearly in section two elements, the one parallel and the other perpendicular to the under surface.

Rotuma; outer reef.

This is by far the most abundant coral on the reefs of Rotuma, and is found in places covering as much as 25 per cent. of its surface. In general appearance its upper surface resembles *M. smithi*, but the colony is always very distinctly pedicellate.

4. *MADREPORA ROBUSTA* Dana (19).

Rotuma; 4 fathoms. A fragment.

5. *MADREPORA PULCHRA* Brook (22).

Var. *alveolata* Brook.

I have referred, after some hesitation, a specimen to this species and variety. The ends of many of the branches have been killed, apparently by sand, and the remaining branches are stunted and much divided near their apices.

Rotuma; boat channel.

6. *MADREPORA AUSTERA* Dana (35).

A much-branched specimen covered with tubi-nariform radial corallites. The surface of the corallum is finely echinulato-striate, and there are a few small obsolescent calices between the large radial corallites. The primary septa in the radial corallites are deep but distinct.

Rotuma; 3 fathoms.

7. *MADREPORA ASPERA* Dana (43).

Rotuma; 3 fathoms.

8. *MADREPORA SCABROSA* Quelch (45).

A horizontally spreading, much divided branch, 14 cm. long, of this species was obtained. The branch is 1.2 cm. thick at its broken end, and the terminal branchlets, which grow up vertically, are about .6 cm. thick, 3 cm. below their apices. The corallites correspond very closely to those of the type, but are rather more appressed to the branches, and a few are large and subimmersed. The under surface of the branch is finely echinulate, and towards the base bare of any corallites.

Funafuti; 35 fathoms.

9. *MADREPORA RETICULATA* Brook (52).

A specimen 15 cm. long was obtained, which closely resembles the type. Some of the tubular corallites of the under surface are 6-9 mm. long and slightly proliferous; they are fused in many places one with another, and by fusion with other branches, towards which they may be growing, give rise to the close reticulations characteristic of the species.

Funafuti; 35 fathoms.

10. *MADREPORA PROFUNDA*, n. sp. (Plate XXIII. fig. 3.)

Corallum consisting apparently of a number of stems arising almost horizontally from an incrusting or pedicellate base, covered above with low twigs about 4 cm. long by .6 mm. in diameter at the base. Branches often somewhat angular, generally about .9 mm. in diameter, in places forming a very irregular network with slightly elongate meshes. The axial corallites are usually oval in shape, and vary up to 2.5 mm. in long diameter by 1.5 mm., the opening of the calice being about 1 mm. by .6 mm., they are about 1 mm. exsert. Radial corallites near the ends of the branches nariform and somewhat compressed, the rim of the calice extending at right angles to the stem and its opening being oval or boat-shaped; a few are tubular and slightly proliferous. Toward the bases of the twigs the radial corallites become gradually less prominent, giving place on the main branches to subimmersed and completely immersed corallites. The latter very regularly cover the main branches, and are situate about 3 mm. from one another; they vary from 1-1.3 mm in diameter. In nearly all the calices the primary septa can be recognized as narrow lamellæ, the directives rather more prominent; in the immersed corallites the secondary septa too are quite distinct. The surface of the corallum is dense and very echinulate; the walls of the corallites are strongly striate, and their edges are much spined.

Funafuti; 30 fathoms.

The specimens on which this species is founded consist of a very large number of fragments, all obtained in the same haul of

the dredge and probably from the same colony. The species, though distinctly belonging to the subgenus *Odontocyathus*, differs from all its previously described species in the extremely large immersed corallites found on its main branches and under surface.

11. *MADREPORA SURCULOSA* Dana (97).

There are two specimens of this species in the collection, which are prostrate in form and have the branches on the under surface completely fused along their length except at the extremities. The under surface, close to the pedicle, is bare even of completely immersed corallites.

Funafuti; lagoon shoals.

12. *MADREPORA LATISTELLA* Brook (107).

Funafuti.

13. *MADREPORA SINENSIS* Brook (110).

I have referred a specimen 16 cm. in diameter to this species. The colony is very regularly incrusting, with short branches 4-6 mm. in diameter on the upper surface, often fused with one another. Towards one edge some thicker branches project horizontally; they are very regularly covered with short branches on their upper surfaces, but on the sides have a few tubular corallites and on the under surface immersed calices. The surface of the corallum is very regularly echinulate, in some places striate.

Funafuti; outer reef.

14. *MADREPORA HEBES* Dana (128).

Rotuma; 4 fathoms. A fragment.

15. *MADREPORA MONTICULOSA* Brook (130).

A small specimen 17 by 10 cm. was obtained. The corallum is 3.5 cm. thick where it was broken off from a larger mass and about 1 cm. at the edge. The upper surface is covered by low subconical prominences .5-1.5 cm. high. The edge is slightly lobed and crowded with subequal, low, thick-walled corallites, among which the axial can scarcely be distinguished.

Rotuma; outer reef.

16. *MADREPORA HISPIDA* Brook (132).

The specimen, which consists of one thick, somewhat rounded branch about 26 cm. long, corresponds very closely in all respects with the type. It is 7 cm. thick at the base, and evidently grew in a semi-recumbent position; the under surface, where it is not dead, is smooth and has a few scattered immersed corallites.

Rotuma; outer reef.

17. *MADREPORA SECURIS* Dana (133).

Wakaya, Fiji; outer reef.

18. *MADREPORA CUNEATA* Dana (134).

There are four specimens of this species, three of which consist of horizontally spreading plates with well-developed epitheca, while the fourth is a much-contorted stem 4.5 cm. high.

Wakaya, Fiji, and Funafuti; outer reefs.

19. *MADREPORA FRUTICOSA* Brook (140).

Funafuti; 6 fathoms. Fragments.

20. *MADREPORA GEMMIFERA* Brook (146).

A branch obtained off the chain of a buoy in Levuka Harbour, Fiji, weighed 20 grams, a growth of not more than 22 months.

Levuka and Wakaya, Fiji; 0-6 fathoms.

21. *MADREPORA SERIATA* Ehrenberg (156).

Rotuma; 3 fathoms. Fragments.

22. *MADREPORA BÆODACTYLA* Brook (168).

There are two specimens of this species, the one closely resembling the type and the other the variety from Rodriguez, mentioned in the Brit. Mus. Catalogue.

Funafuti; outer reef. Rotuma; 3 fathoms.

23. *MADREPORA LORIPES* Brook (176).

I have referred a small specimen to this species. Its surface is very distinctly echinulato-striate, and its branches have in one place anastomosed one with the other.

Funafuti; 6 fathoms.

24. *MADREPORA POLYMORPHA* Brook (182).

Rotuma; 3-6 fathoms.

25. *MADREPORA ANGULATA* Quelch (212).

I have referred a branch to this species, which very closely resembles the type. The radial corallites on some of the twigs are situated very regularly in four rows.

Funafuti; 35 fathoms.

II. Genus *TURBINARIA*.

Turbinaria Oken, *Lehrb. der Natur., Zool.*, 1815.

There is a marked absence of this genus both at Funafuti and Rotuma, only one colony having been found, while in Fiji three species were obtained.

1. *TURBINARIA DANAE* Bernard (3).

There are two fragments of this species, which very closely approach the types. The largest of the two specimens is a pronounced inner fold, having on its edge very prominent corallites, some being 6 mm. long with buds at their sides.

Wakaya, Fiji; lagoon, 1-2 fathoms.

2. *TURBINARIA SCHISTICA*, n. sp. (Plate XXIV. fig. 9.)

Corallum very closely approaching that of *T. orbicularis*, but altogether much thicker and more massive. Edge of the corallum generally about 3 mm. thick, not wrinkled on the under surface. Calices usually 2-3 mm. in diameter, with margins slightly protuberant as thin rings about 1 mm. high. There are in most calices 24 thin septa with rather rough edges, projecting but little into the calice; their upper edges project at a very acute angle to the edge of the calices and their inner edges are almost vertical. The columella is very conspicuous, round and rather protuberant, situated about 1.5 mm. below the upper opening of the calice and formed by a rather coarse flaky reticulum. The cœnenchyma is composed of a fine reticulum, moderately spiny on the surface, and formed of somewhat thin and flattened elements, which give it a distinctly flaky appearance.

Wakaya, Fiji; lagoon, 1-2 fathoms.

There are two fragments of this species, the edges of a cup. The greater part of the under surface of the corallum of both has been killed, giving somewhat the appearance of an epitheca, but the sections show very clearly the extent to which it has gone on; the corallum of one piece, 3.5 cm. from the edge of the cup, is 2 cm. in thickness, but of this the lower half is quite dead.

The species very closely approaches to *T. orbicularis*, but it is at once separable by the characters of the cœnenchyma.

3. *TURBINARIA PULCHERRIMA* Bernard (30).

One small specimen, weighing 45 grams, a growth of less than 22 months, was obtained off the chain of a buoy. Owing probably to its position, its growth is rather more irregular than the type.

Levuka, Fiji; harbour, 2 fathoms.

4. *TURBINARIA MESENERINA* Bernard (37).

I have referred six pieces from the same colony to this species, with which they closely correspond in their cœnenchyma and in the parts within the calices.

Rotuma; pool in outer reef.

From my specimen, it seems as if this species should rather be placed among the *foliate types*. The type specimen in the British Museum grew probably in a hole near the extreme outer edge of the reef, where its upper edges would be just awash at low tides, and consequently would be unable to grow further upwards; everywhere between its folia also are the tubes of worms and molluscs.

III. GENUS *ASTRÆOPORA*.

Astræopora Blainville, Dict. des Sci. Nat. t. ix. p. 348 (1830).

There are eight specimens of this genus, which I have referred to four species. The genus, although represented by so few species, is a fairly abundant one in the lagoon of Funafuti and the boat-

channel of Rotuma. Great spreading masses are formed which die in the centre and become somewhat hollowed out, but continue to grow at the sides. The mode in which the colony grows, whether explanate, pulvinate, or globular, is, I think, due to local conditions as to depth below low tide and current, and also to the character of the rock on which the embryo first fixed itself. In my collection there are three specimens of *A. listeri*, one of which is typically pulvinate, one shows approximation to the globular type, while the third, a young colony about 6 cm. in diameter, is distinctly globular. The great variety shown between the upper and the under sides of the species I have named *A. tabulata* seems to show that there is little value in the naming of species of this genus from the skeleton alone.

1. *ASTRÆOPORA LISTERI* Bernard (6).

This species seems to be an extremely variable one, but the three specimens in the collection closely correspond to types in the British Museum.

Funafuti; lagoon.

2. *ASTRÆOPORA TABULATA*, n. sp. (Plate XXIII. fig. 4.)

Corallum showing the pulvinate type of growth. Corallites slightly protuberant, hemispherical, generally about 3 mm. high, often coalescing at the sides, but the valleys between usually distinct, with here and there young corallites. The calices are from 1·8–2·2 mm. in diameter and from 3–4 mm. apart; the primary and secondary septa are of nearly equal size, scarcely visible above, but below can be traced as 12 very thin laminate narrow plates with smooth edges, not meeting at the centre. A few of the tertiary septa are sometimes visible. About 7 mm. below the opening of the calice somewhat thick tabulæ, often arched in the centre, occur; of these there are about 11 in 1 cm., but the septa are very distinctly continuous through them and the cell is not filled up at all with stereoplasm. The cœnenchyma is extremely echinulate, ending on the surface with somewhat flattened low spinulous projections, which on the sides of the corallites tend to form very regular striations. In sections the interlacing of the costal elements from neighbouring cells is very distinctly visible. The colour of the living colony is green.

Funafuti; lagoon. Rotuma; boat-channel.

I have referred to the same species another specimen from Funafuti, which is apparently the under part of a colony, the top of which has broken off and rolled over; the greater part of it has been killed by incrusting nullipores and the corallites on its surface do not generally project. The calices vary greatly in size, and generally have the primary septa distinct and projecting nearly to the centre of the cell; the secondary septa are small. The cœnenchyma is very echinulate, and the section shows the same arrangement of the tabulæ and of the costal elements as in the types above.

3. *ASTRÆOPORA PUNCTIFERA* Bernard (11).

I have referred a specimen to this species, but I am doubtful whether the species is really distinct from *A. listeri*.

Rotuma; boat-channel.

4. *ASTRÆOPORA OVALIS* Bernard (12).

There is one specimen of this species, which is considerably larger than the type but exhibits quite as regular a mode of growth and differs in no respect.

Funafuti; lagoon.

IV. Genus *MONTIPORA*.

Montipora Quoy & Gaimard, Voy. 'Astrolabe,' Zooph. p. 247 (1833).

Montipora Bernard, Brit. Mus. Cat. Madreporaria, vol. iii. (1897), p. 13.

Of the nine species represented, all with one exception were obtained from the comparatively still water of the lagoon or boat-channel.

The living tissues form a layer a few mm. thick on the surface of the colonies; underneath this the corallum is generally much corroded, and bored by *Chætopoda*, *Gephyrea*, and *Mollusca*, especially *Lithodomus*. The massive forms, after attaining a certain thickness, are often killed at the base by sand, &c.; the dead part begins to be corroded, but a fresh growing edge forms, and a constant struggle seems to be going on between the edges and the sand beneath. Often the stem becomes completely worn through, so that the mass falls over, and is at once killed by the sand, in its turn perhaps forming a fresh foundation for the larvæ of the same or some other genus of coral. It is interesting to note that I never found any colony with the upper part hollowed out or dead, or in any way exposed at even the lowest tides.

I am indebted to H. M. Bernard, Esq., M.A., of the British Museum, for naming the species. Of these, four are new and three have been already described in an appendix to the British Museum Catalogue of the genus. Mr. Bernard has also very kindly described the new species, *M. columnaris*, here given.

A. *Foveolate*.1. *MONTIPORA COLUMNARIS* Bernard, n. sp. (Plate XXIII. fig. 5.)

Corallum grows in erect, irregular spikelets, thickened by repeated incrustations. Tips pointed or flattened. Each new growth forms a living cap on the stock, 6-7 cm. in length.

The calicles are numerous, almost uniformly scattered, about 1 mm. apart and .6 mm. in diameter, with many smaller appearing on the thick interstitial ridges; conspicuous, deep, with open fossa and feeble septal apparatus (from 6-12); with solid columella-like body, deep down in the fossa.

The cœnenchyma consists of a dense reticulum, which early solidifies, tending thereby to diminish the apertures of the calicles and to further obliterate the septa. In the section of the column the thin axial strand is hardly distinguishable from the cortical layer; both are very dense. At the tip of the growing stock the reticulum may be lighter and run in parallel striæ up the growing point. The interstitial ramparts, which are more or less obliterated towards the bases of the stock, are round and thick, but near the growing point may be sharper and thinner.

Rotuma; boat-channel. Wakaya, Fiji; lagoon.

Under this heading two specimens, which appear to be related, are grouped in spite of some important differences. Superficially they resemble detached spikes of *M. irregularis* from Zamboanga. They differ, however, in the apparent absence of any expanding and incrusting base, in the smaller size of the calicles, in the characters of the septa (which are very well developed in *M. irregularis*), and in the density of the cross section. In *M. irregularis* the spikes appear to grow rapidly and to be through-out of a light spongy reticulum. In the coral under discussion the growth is apparently slow and the corallum early solidifies.

The two specimens differ in that the one from Rotuma has a sharp pointed tip (with a few broken off spikes), the septa very fully developed and the cœnenchymatous reticulum dense, even right up to the growing tip; while in the specimen from Fiji the tip is a sharp flattened edge, the septa are rather better developed, and the reticulum near the growing tip is lighter, more delicate, striated as mentioned above, and the whole is more foveolate.

The two specimens are classed together because the manner of growth appears to be the same, both have nearly solid section, and the lower, more adult portions of the stocks are very similar. Owing to the flattening of the interstitial ramparts near the bases of the stocks, the specimens might perhaps be classed under the heading glabro-foveolate.

2. MONTIPORA FOVEOLATA Dana (39).

One specimen from Rotuma shows typical foveolation on one side, but on the other the ramparts are broken up into curved plates (*cf.* specimen *e* Brit. Mus. Coll.), which tend to rise above the level of the surface (*Bernard*).

Rotuma; boat-channel. Wakaya, Fiji; lagoon.

3. MONTIPORA SOCIALIS Bernard (40).

The specimen of this species differs from the type specimens in the Brit. Mus. (which are fragments from the edge of a larger stock) chiefly in being massive and of a closer consistency. The ridges thinner, sharper, and taller (*Bernard*). The calices are larger than in the type, being from 1-1.5 mm. in diameter; primary septa also distinctly larger than secondaries.

Rotuma; boat-channel.

4. *MONTIPORA PROFUNDA* Bernard (137).

Funafuti; lagoon.

5. *MONTIPORA CALICULATA* Dana (41).

Var. *piriformis* Bernard (pp. 59 & 178).

Funafuti; lagoon.

6. *MONTIPORA SAXEA* Bernard (139).

Besides the two specimens in the British Museum, there is a third specimen at Cambridge, which appears to be the free end of a massive block.

Its edges are perfect, about 3 mm. thick, either creeping over a much-corroded substratum of the same species of coral, or free for 2-3 mm., and closely followed by a well-developed epitheca.

Funafuti; lagoon.

7. *MONTIPORA VERRUCOSA* Lamarck (80).

On one specimen a colony of *Pocillopora suffruticosa* has settled.

Funafuti; lagoon.

8. *MONTIPORA INCOGNITA* Bernard (109 & p. 181).

This species grows in large, generally horizontally spreading masses, sometimes a metre or more in diameter, with a broad attachment in the centre. The edges are often free for 30 cm. or more, but occasionally supplementary attachments are formed to the rock beneath. The upper surface, especially over the central point of attachment, is studded with nodules, 3-6 cm. high, often dead at their summits.

Funafuti; 0-7 fathoms, extremely common both in the fissures of the outer reef and on the shoals within the lagoon.

9. *MONTIPORA GRANIFERA* Bernard (141).

Funafuti; lagoon.

V. Genus *PORITES*.

Porites (pars), Lamarck, Hist. Anim. sans Vert. ii. p. 267 (1816).

Porites, Duncan, Rev. Madrep. p. 187.

There are 45 specimens of this genus in the collection, some fragmentary. I have been able to refer 38 of these to 9 species, the variations in which I have carefully recorded. Of these 6 species seem to me to be new, and I have redescribed one old species (*P. arenosa*) and added two varieties to it. I have had the advantage of comparing my specimens with the 'Challenger' types in the British Museum; these seem to have been described rather hastily, and at least two from worn specimens, the characters of the calices of which are rather obliterated.

The youngest colony in the collection, which I have not referred to any species, has 9 calices in 3 rows. The massive colonies

seem to me to be formed from such by the edges creeping out by budding-off calices regularly in lines. Then thickening takes place by the direct upward growth of the cells and budding in the cell-walls, where three or more calices meet.

It is interesting to note that no branching-forms were obtained at Funafuti or Rotuma, and that no colonies were found on the outer reefs proper of these islands.

1. *PORITES ALVEOLATA* Edwards & Haime. (Plate XXIV. fig. 1 *a*.)

Porites alveolata Edwards & Haime, Cor. iii. p. 178.

I have referred a small, closely incrusting colony to this species. Its calices are small, 8-9 in 1 cm., generally considerably deeper than broad, with relatively thick walls covered with rough, somewhat granular spines. The septa are 12 in number, thin, and little projecting, with almost perpendicular edges. In front of and joined below to the primaries are 4-6 thick, rough, but little projecting pali. Deeper in the calices both these and the septa seem to be united by a ring of corallum, leaving in the centre, as there is no columella, an extremely deep axial fossa.

Rotuma; boat-channel.

2. *PORITES VIRIDIS*, n. sp. (Plate XXIV. figs. 1 *b*, 2.)

Corallum massive, uneven, irregularly monticulose, incrusting at the base; growing edges thin, generally not more than 2-3 mm. in thickness, closely covered by the epitheca, and often free for 5-10 mm.

Calices deep (1 mm.), polygonal, generally very regular in size, 1.5-2 mm. in diameter, or about 6 in 1 cm.; in the deeper valleys smaller and irregular, often elongate. Cell-walls very thin on the surface, but much thicker below, being at the base of the calice about a third its diameter in breadth; where 3-4 calices meet they are often much thicker, and fresh calices are budded-off. Upper edges of the walls covered with low, blunt, rough spines, and just within the calice, apparently attached to its wall, there are 12 thick, rough, projecting spines, corresponding to the septa which arise deeper. Secondary and primary septa often fused at their edges, and fused to the latter are 4-6 generally thin, blunt, rough, and little projecting pali. Lower in the calice a ring of corallum is often seen, joining all the edges of the septa together; from this strands of corallum run to join in the centre of the axial fossa, giving rise apparently to the small blunt columella, which is almost as prominent as the pali.

In section the corallum is seen to be dense and heavy, the walls of the cells thick and compact, with a very regular, close, palisade arrangement across the cells below the base of the columella.

VAR. *APALATA*. (Plate XXIV. fig. 1 *c*.)

The calices are generally less deep than in the type, and have rather thicker walls. The septa are 12 in number, generally less

regular and thinner than in the type, with their edges seldom fused one to another; in some of the cells 2-4 low pali can be distinguished, appearing like mere thickenings at the edge of the septa, but usually they are completely absent or quite indistinguishable. Columella generally absent or indistinct; in some of the calices strands of corallum occupying the bottom of the axial fossa, which in others is very deep.

The type specimens (4) of this species were all obtained from a pool in the reef near the island of Solkopi, to the east of Rotuma. The variety was found on the reef quite near, and probably the variations in its calices are correlated with its position. The types of the species are two massive pieces broken off from the edges of colonies and two quite young colonies. The latter have the corallum less dense, walls thinner, septa seldom fused, pali often more marked and regular, and columella sometimes quite small or even indistinguishable.

The specimen of the variety is rather more uneven and mamillate on the upper surface than the type. To it I have also referred a small incrusting specimen, which differs in having the septa more marked, regular, and broader, with both pali and columella indistinct.

The calices in all the specimens are in places arranged in lines, the walls between neighbouring calices in the line being thinner than between the calices of the one line and the next; such lines are rather irregular, but usually seem to run parallel to the growing edge. The colour of the living colonies, both type and variety, was the same, a very bright dark green.

3. *PORITES PURPUREA*, n. sp. (Plate XXIV. figs. 1 *d*, 3.)

Corallum massive, uneven, irregularly monticulose, and mamillate, or with short columniform outgrowths, incrusting at the base; growing-edges 1-2 mm. thick, closely covered by the epitheca, and often free for a few millimetres.

Calices usually quite shallow, polygonal, about 2 mm. in diameter on the tops of the mamillations and on the columniform outgrowths, but much smaller in the valleys between and irregular in outline. Cell-walls sometimes quite thin on the surface and angular in section, but more often, especially near the base of the colony, quite blunt and as much as .5 mm. thick. Upper edge of the wall covered with rough blunt spines, on the thin walls a single row flattened at right angles to the wall between neighbouring calices and appearing continuous with the septa within each; the thick walls present an appearance as of three rows of spines, a central higher one, and a row on each side, but the latter is really a large tooth on the upper end of the septa, projecting in the thin-walled calices almost at right angles to the walls, but in the thick-walled almost vertically outward. Septa 12, secondaries often fused with the primaries, usually thin with rather rough sides, projecting for about a third its breadth into

the cell. Pali usually 5-7, opposite and fused to the edges of the septa, sometimes quite thin and styliform, but generally thick with rugged sides; their summits usually level with that of the wall between the calices. Deeper in the cell septa and pali joined by a ring of corallum, from which arise 3 or 4 strands to meet in the centre of the calice, where the columella projects as a distinct thin style with its summit in the thick-walled calices little below those of the pali.

In section the corallum is seen to be composed of very coarse elements disposed in a very regular cross palisade arrangement.

Funafuti; lagoon shoals.

There are three specimens of this species—one a mamillated mass about 6 cm. high by 7 cm. broad, the second a column-like outgrowth, covered on the sides with mamillations, 11 cm. high by 6 cm. in diameter at the base, while the third is a mass intermediate in form between these two. The colour of the living colony with the polyps expanded is a dark purple, that of the cleaned corallum light brown.

The species is very abundant at Funafuti, and resembles in some respects *P. columnaris* Klunzinger, but I nowhere saw anything approaching the long columniform outgrowths which are described for that species.

4. *PORITES TRIMURATA*, n. sp. (Plate XXIV. figs. 1 e, 4.)

Corallum massive, uneven, slightly monticulose, incrusting at the base, but in the larger colonies with no free growing-edge; commonly flat table-topped, with a broad central pedicle and edges about 7 mm. thick, covered with living calices which extend for about 2 cm. on the lower side.

Calices polygonal, moderately deep, about 1.5 mm. in diameter, or 6 in 1 cm., smaller in the depressions. Cell-walls very thin, regular, dense, and with few perforations, covered on the upper surface with thick, rough, slightly flattened spines, which correspond in position to the septa in the calices on each side. Septa 12, appearing on the walls .4-.5 mm. below their upper edges and projecting into the calices for about a quarter their breadth, usually rather thick with bluntly spinulous summits and rough sides; inner edges seldom fused with one another, thickened, rough, very slightly projecting, apparently due to the fusion with the pali, which would then vary in number from 6 to 12. Inside the calice, between the thin wall proper and the point where the septa may be seen distinctly arising, the wall is covered with low, broad, rough spines, which in some parts form a distinct ring within the calice, arising inside the true cell-wall from apparently another wall, which is closely connected to it by the elements of the corallum. On the undersides of the table-formed colonies the calices present the same characters, but the pali are more distinct and only lie opposite the primary septa, with which they are fused below. The septal edges and pali are joined below by a ring of corallum, from which usually 6 elements arise, fusing in the centre

of the calice, where a low, thin, often much-flattened columella arises.

In section the layer with living tissues is seen to be about 3 mm. thick. The corallum is formed of fine elements, with a very close-latticed arrangement, giving it an appearance of great density. Where the living tissues do not cover the corallum, it is much pitted and corroded.

Funafuti; lagoon shoals. Wakaya, Fiji; lagoon.

There are in the collection portions of three colonies and one young colony. The latter is closely incrusting at the base and differs from the older colonies in having the inner wall of the calices less distinct, in most parts seemingly fused with the true wall. If the wall between the calices in the *Porites* is, as I believe, the true theca, then these inner walls must be regarded as supplementary thecæ. From the comparison of the exposed sections of this species with those of *P. purpurea* and *P. viridis*, I am inclined to believe that the cell-walls of these and other relatively thick-walled species are formed of three elements—first the fused thecæ which primarily would be double, and then two supplementary thecæ.

The pali vary extremely, but, from the comparison of the calices in the different specimens, I think that all the septa have primitively a prominent paliform tooth. In front of the primary septa then appear the pali, thin, styliform, equally prominent projections, which fuse almost at once with the edges of the septa, giving rise to a crown of large and small prominences around the large central fossa, in the middle of which the columella arises. Secondly, owing to physical causes, these may, I think, be enlarged on the secondary septa, giving the appearance of a larger number of pali.

From the examination of a large number of specimens, it seems to me that primitively there are 6 pali in all the massive species, and that all modifications are really due to causes such as I have sketched above.

5. *PORITES UMBELLIFERA*, n. sp. (Plate XXIV. figs. 1 f, 5.)

Corallum massive, uneven, slightly monticulose above, often table-topped with a broad central attachment.

Calices polygonal, shallow, and almost superficial in places, about 1.3 mm. in diameter, or 7 in 1 cm. Cell-walls thin, with few perforations, with rough uneven summits without any definite spines, but higher opposite to the septa. Within the wall arises a circle of 12 thick, large, rough, thorny spines, with their summits level with the top of the wall, lying on the top of a definite supplementary wall (or theca), which is relatively more internal than in *P. trimurata*, but less perfect, consisting in many places of thickenings on the sides of the septa which have not yet fused. The septa (12) then get very thin and almost smooth-walled, running into the calice for about a third of its breadth, where the secondaries and primaries are generally fused together and with the pali, giving 6 large, rough, prominent styles with their summits

little below that of the wall. In the centre of the cell the columella is similar in appearance to the pali, and almost as prominent, springing from the fusion of a number of strands of corallum arising from a regular, deep ring joining the edges of the septa and pali.

In section the corallum is seen to be formed of rather coarser and more open elements than in *P. trimurata*, with the usual palisade arrangement. It is also distinctly less heavy.

Funafuti; lagoon shoals.

There are two specimens, a chip from the summit of a massive block and a part of the edge of a table-topped colony. The former shows very well the triple nature of the wall, but has the pali and columella less distinct.

The species is closely allied to *P. trimurata*, but is at once distinguished by its smaller calices, more open corallum, and regular pali.

6. PORITES PARVISTELLATA Quelch. (Plate XXIV. fig. 1 g.)

Porites parvistellata Quelch, Challenger Report on Reef-Corals, p. 184, pl. xi. figs. 8-8 a.

I have obtained two specimens of this species, which very closely correspond to the type in the British Museum. The calices generally are about 1 mm. broad, and the same in depth, but near the edges of the colony tend to become somewhat larger, thinner-walled, and almost superficial.

Rotuma; boat channel.

7. PORITES ARENOSA Esper. (Plate XXIV. figs. 1 h, 6.)

Madrepora arenosa Esper, Pflanz. t. i., Suppl. p. 80, Madr., tab. lxxv. (1797).

Porites arenacea Lamarck, Hist. des Anim. sans Vert. t. ii. p. 270 (1816).

Porites arenosa Milne-Edwards & Haime, Cor. iii. p. 180.

In the collection there are 13 specimens, which closely resemble the published descriptions of this species, but all of which bear considerable resemblances to *P. lutea* also. In addition I have examined a large number of named (?) and other specimens in the British Museum without being able to find any point which I should consider of specific difference between them. I leave, therefore, the additional characters of the two so-called species, given by Klunzinger, Quelch, and others, with the remark that a series shows very great variability in the arrangement of all the parts within the calices, and secondly that no character taken from the form of the colonies of the two species can be of any specific importance. The description would then be as follows:—

Corallum primarily incrusting at the base, with a great tendency to thicken, so as to form moderately thick flat masses with generally level summits, but occasionally a few low, rounded elevations. The top, on the colony reaching a certain size, invariably dies in

the centre (or is killed by the accumulation of sediment), but the polyps remain alive at the edges, which are usually not more than 12 cm. broad, so that flattened, hollowed-out masses often 2 metres or more in diameter result. The edges locally, however, are often killed, so that the living corallum forms no continuous line but a series of blocks, varying greatly in size, round the whole mass, often attached by their whole bases, but often by quite narrow stalks, so that they are frequently broken off (owing to the weakening caused by the boring into them of worms and other animals). The growing edge of the corallum where it is visible is extremely thin (1 mm.), very closely incrusting, the epitheca extending nearly to the edge.

Calices polygonal, shallow, 1.4 mm. in diameter, or 7 in 1 cm., smaller in the valleys. Cell-walls distinct, thin and linear on the surface, not thickened below; upper edges smooth, undulating, or covered with low, rough spines, corresponding in position to the septa in the neighbouring calices. Septa 12, rather thin, almost equal-sized, projecting into the calice for about a third of its breadth; edges of secondaries and primaries sometimes fused, with generally three rough spiny prominences on the upper edges, the first close to the wall of the cell, the second slightly deeper, about halfway along, and the third at its free edge; the latter spine sometimes fused with the middle one, larger on the primaries than on the secondaries, where it is generally scarcely distinguishable and rather deep in the cell. Pali 6, fused with the edges of the primary septa, but little projecting above its edge; their summits about .4 mm. below that of the cell-wall. Septal edges (and pali) often joined together, but no distinct ring of corallum. Columella very variable, often scarcely noticeable, but usually a distinct, thin, flattened plate with its summit little below those of the pali, arising from the junction of several strands of corallum from the septal edges in the centre of the calice.

In section the corallum appears somewhat open, the longitudinal elements rather coarse, while the transverse are very delicate and thin.

Funafuti; lagoon shoals and 7 fathoms.

Var. *LUTEA*. (Plate XXIV. fig. 1 *k*.)

Porites conglomerata, var. *lutea* Quoy & Gaimard, Voy. de l'Astrob., Zooph. p. 249 (1833).

Porites lutea Edwards & Haime, Cor. iii. p. 180.

Porites lutea Klunzinger, Die Korallthiere des roth. Meeres, t. ii. p. 40.

In this variety the wall of the calices is usually rather rougher than in the type. The septa are slightly thicker, the two outer sets of spines generally smaller, the edge of the primaries fused with the pali, giving 4-6 large, thick, rough and prominent points round the centre of the calice, in which a small low columella can with difficulty be distinguished.

Funafuti; lagoon shoals. Wakaya, Fiji.

Var. *PARVICELLATA*. (Plate XXIV. fig. 1 l.)

In this variety the calices are much smaller than in the type, being seldom more than 1 mm. in diameter. The calices are similar in appearance, but the septa are rather rougher, and the pali more distinct from the septa and more prominent than in either the type or the preceding variety. The columella, too, is thicker and more prominent.

Funafuti; lagoon shoals.

The species above described is subject to much variation in the parts within its calices; and in different parts of the corallum nearly all the stages between the type and these two varieties can be found. For instance, the septa in some cells of the same colony are quite thick with no distinguishable pali, while in others the septa are thin and the pali well marked, perhaps completely separate from the septa. In a curve of variation of these characters there would seem to be two prominent points which I have recognized in my descriptions of *P. arenosa* and its var. *lutea*. It seems to me, too, that *P. conglomerata* (Esper), *P. parvistellata* (Quelch), and probably several of the West-Indian species, will have to be placed under this head, when a long series is examined.

The var. *parvicellata* differs mainly in the size of its calices, but their great regularity precludes the idea of this being due to local conditions.

The living colonies, which are of a golden-green colour, are common on all the shoals of the lagoon of Funafuti, but are not in any way uncovered, even at the lowest tides.

8. *PORITES SUPERFUSA*, n. sp. (Plate XXIV. figs. 1 m & 7.)

Corallum rough, closely incrusting, retaining the shape of the surface over which it is growing; the edges thin, 1-1.5 mm., closely followed underneath by the epitheca, often free for a few mm. where the incrustated surface is uneven, and so easily bridging over any small cavities in it.

Calices usually round, .5-9 mm. in diameter, in the depressions polygonal and still smaller. Cell-walls very thick, obtuse and solid, often as broad as the calices, but in the valleys quite thin and angular. Upper edge of the wall covered with low, rough, blunt spines, giving them a very granular appearance. Septa somewhat irregular, usually 12, generally rather thick with rough sides, arising deep down in the calices and projecting for about a third their diameter, primaries and secondaries sometimes fused at the edges. Pali fused below to the septal edges, thick, rough, blunt and extremely prominent, their summits almost level with the top of the walls. There is visible no complete ring of corallum joining the septal edges and pali, but usually 3-4 strands from the pali run across the calicular fossa, meeting in the centre, where a small, prominent, styliform columella is situated.

In section the elements of the corallum present an open pali-sade arrangement and are noticeably thin and delicate.

Funafuti; passage in reef, 5 fathoms.

The specimen is an incrusting growth 12 by 7 cm., in no part seeming to be as much as 1 cm. thick. In places the edges have been killed, and two pieces have thus been cut off, but were evidently still alive when first obtained. The colour of the living colony was green. The walls of the cells are studded, where three or more meet, with the open ends of the calcareous tubes of some worm; these are about .4 mm. in diameter, and around many the corallum has taken on an appearance as if they were lying in the middle of a calice.

9. *PORITES EXILIS*, n. sp. (Plate XXIV. figs. 1 n & 8.)

Corallum thin, incrusting, sometimes almost massive in the centre, with a few mamillations; growing edge about 1.5 mm. thick, often free for 2-3 cm., closely followed by the epitheca, which usually exhibits regular concentric markings.

Calices shallow, about 1 mm. in diameter or 9 in 1 cm., polygonal or more or less round, in some parts arranged almost in lines. Cell-walls thin but, owing to the upper edges being covered with spines, flattened at right angles to the walls, appearing on the surface rather thick; these spines are very rugged and correspond more or less to the septa. Septa 12, thick with rough sides, projecting into the calice for about a quarter its diameter; the upper edge, where it is attached to the cell-wall, carrying a large, thick, rough spine, projecting considerably into the cell and somewhat upwards, below these running into the calice at right angles to the cell-wall. Inner edges of primaries and secondaries often fused, and below connected together by a ring of corallum, sometimes incomplete in one part. Pali generally 6, fused to the septa, rough but somewhat pointed, with their summits little below the level of the top of the wall. From the ring of corallum extend inwards a number of elements which fuse in the centre of the calice, where the columella arises, styli-form but very rough, with its summit almost level with those of the pali.

In section the corallum is seen to be formed of rather coarse elements, having the regular cross-palisade arrangement and rather open meshes.

Funafuti; 7 fathoms. Rotuma; 3 fathoms.

There are three specimens from Funafuti, apparently from two closely incrusting colonies, exhibiting typically the above arrangement within the calices. The specimen from Rotuma has a few low mamillations on the incrusting base; while the calices over the incrusting part are quite typical, those on these elevations have their septa much thinner, arising higher up on the walls and projecting straight into the calices so as to often almost completely obliterate both the large spine at their upper ends and the pali fused to their free edges, the ring of corallum, joining which, is usually higher up in the cell and more distinct. The colour of

the living colony is a brownish black, that of the cleaned corallum brown.

The species is nearly related to *P. lichen* (Dana) and *P. echinulata* (Klunzinger), but the arrangement of its septa and columella is quite distinct.

In addition to those mentioned above I have fragments, which I believe to be referable to *P. gaimardi* (Wakaya, Fiji), *P. tenuis* (Rotuma), *P. favosa* (Wakaya, Fiji), and *P. cribripora* (Rotuma), although all of them exhibit considerable variations; three others, all from Funafuti, seem referable to new species. Of the latter I find no authentically named specimens in the British Museum, but it does not seem to me advisable to make types of mere fragmentary specimens, on which the variations cannot be properly studied.

EXPLANATION OF THE PLATES.

PLATE XXIII.

- Fig. 1. *Madrepora crateriformis*, n. sp., $\times \frac{1}{2}$, p. 258.
 2. *Madrepora rotumana*, n. sp., $\times \frac{1}{2}$, p. 258.
 3. *Madrepora profunda*, n. sp., $\times \frac{1}{2}$, p. 260. 3 a. End twig of same, $\times 1$.
 4. *Astræopora tabulata*, n. sp., $\times \frac{1}{2}$, p. 264. 4 a. Single calice.
 5. *Montipora columnaris*, n. sp., $\times \frac{1}{2}$, p. 265.

PLATE XXIV.

- Fig. 1. Sections through the calices of the species of *Porites* along the primary septa and through the columella:—(a) *P. alveolata*; (b) *P. viridis*; (c) *P. viridis*, var. *apalata*; (d) *P. purpurea*; (e) *P. trimurata*; (f) *P. umbellifera*; (g) *P. parvistellata*; (h) *P. arenosa*; (k) *P. arenosa*, var. *lutea*; (l) *P. arenosa*, var. *parvicellata*; (m) *P. superfusa*; (n) *P. exilis*. $\times 16$.
 2. *Porites viridis*, n. sp., single calice, p. 268.
 3. *Porites purpurea*, n. sp., single calice, p. 269.
 4. *Porites trimurata*, n. sp., single calice, p. 270.
 5. *Porites umbellifera*, n. sp., single calice, p. 271.
 6. *Porites arenosa*, n. sp., single calice, p. 272.
 7. *Porites superfusa*, n. sp., single calice, p. 274.
 8. *Porites exilis*, n. sp., single calice, p. 275.
 9. *Turbinaria schistica*, n. sp., single calice, p. 263.

3. On the Geographical Races of the Banting.

By R. LYDEKKER, B.A., F.R.S., F.Z.S.

[Received March 9, 1898.]

(Plate XXV.)

Among the larger Mammals of Asia, the Banting is one of those in regard to which our information is most deficient—the British Museum, in addition to skulls, possessing but three specimens, while only a single living example has been exhibited in the Society's Menagerie.

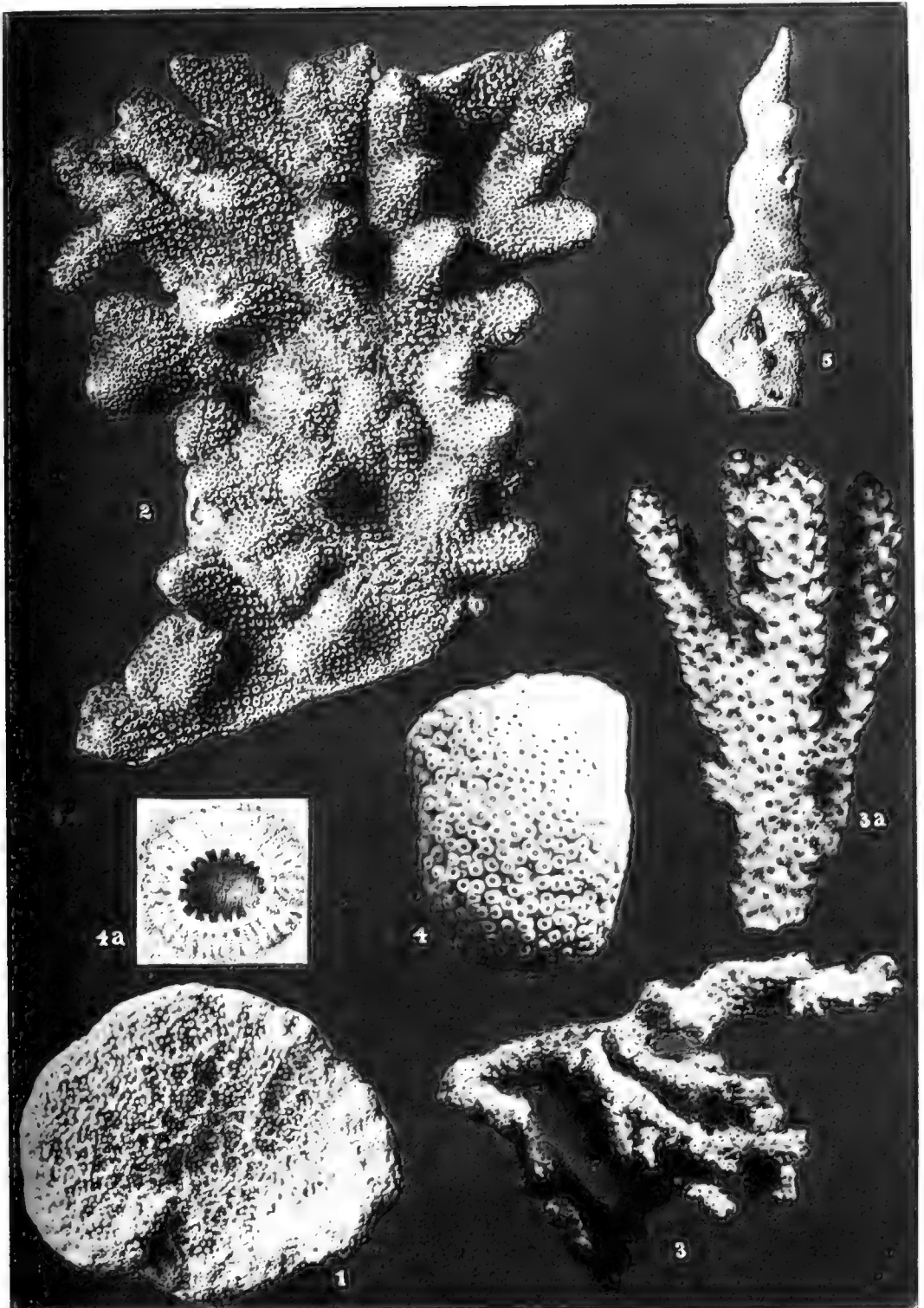

Bemrose, Ltd., Derby.

Edwin Wilson, Cambridge.

CORALS FROM THE SOUTH PACIFIC.



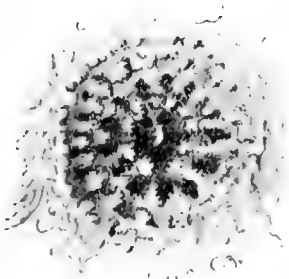

2

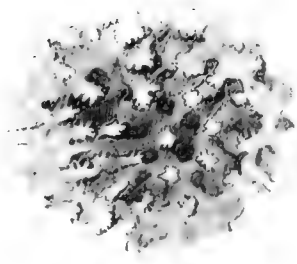

3



4

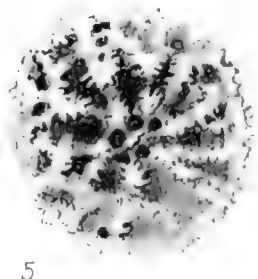

5

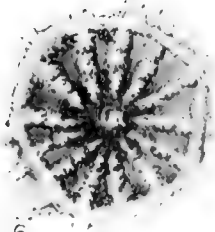

6



7

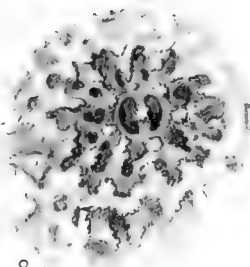

8

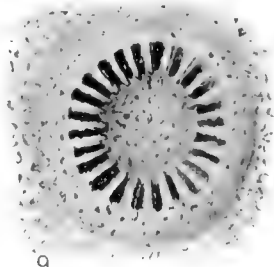

9

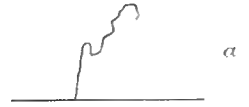

a



b

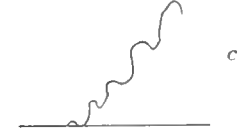

c



d

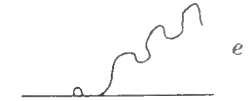

e

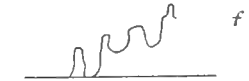

f



g

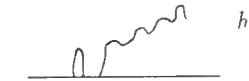

h

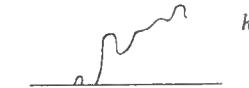

k

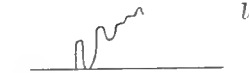

l

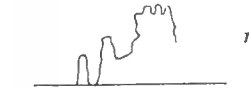

m



n

Bemrose, Ltd., Derby.

Edwin Wilson, Cambridge.



In his 'Mammals of British India,' Mr. Blanford included both the insular and continental forms of the Banting under a single name; but since the publication of his work two memoirs have appeared which leave no reasonable doubt of the existence of at least one continental race distinct from the typical Javan representative of the species. The memoirs in question are one by Vet.-Capt. Evans, published in the 'Journ. Bombay Soc.' for 1895¹, and a second by Surg.-Capt. Wood in the 'Zoologist'² for 1897. A mounted head in the British Museum, which has long puzzled me, serves to show the accuracy of the observations published by the first-named gentleman.

As regards the general characteristics of *Bos sondaicus*, I have nothing to add to those given by Mr. Blanford. The typical Javan race is represented by a mounted specimen—one of the cotypes—in the British Museum; and although most of the hair has been worn off by the handling of generations of visitors, it remains on the head (Plate XXV. fig. 2) and on parts of one side of the body and legs.

In the Javan race, which attains a height of 5 feet 9½ inches at the shoulder, old bulls are described as being nearly black, with a large white rump-patch, and white "stockings" to the legs. The Museum specimen, although probably much faded, is very dark chocolate-brown, becoming nearly black just above the knees, the head being uniform with the back in colour.

On the other hand, the mounted Burmese head is dirty grey, with a light chestnut patch on the nose above the muzzle, which is black; the ears being also grey, with white margins. Now, with the exception of the chestnut mark, this head accords precisely with the description of a bull Burmese Banting by Vet.-Capt. Evans; the general body-colour in that specimen being dark chestnut-red, with a large white rump-patch. A younger bull mounted in the Museum, with the horny boss on the crown of the head not yet developed, is of a light foxy red, with the face grey, and a well-developed rump-patch.

From this evidence it appears to me that the Burmese Banting, which may be typified by the mounted head in the Museum (Plate XXV. fig. 1), is entitled to rank as a distinct race, for which I suggest the name of *Bos sondaicus birmanicus*. It may be characterized by the dark chestnut-red body-colour of the adult bull, the greyish face, and the well-developed rump-patch. Whether it is this or the typical race that occurs in the Malay Peninsula I have at present no information.

With regard to the Manipur Banting, Surg.-Capt. Wood describes the bull as only 5 feet in height, with the general body-colour red, the greater part of the head tawny white, with a greyish-white ring round the eyes, the tips and front margins of the ears black, and no distinct white rump-patch, which is, however, present in the cow. If these characters are rightly described, they

¹ Vol. x. p. 41.

² Ser. 4, vol. i. p. 489.

appear to indicate a third race of the species, for which a new name may be subsequently requisite.

In any case the Manipur locality is of interest, as being more northerly than any as yet recorded for the species. Blyth suggested that the Banting would be found in the ranges to the east of Chit-tagong, and it is possible that in this district the Manipur form may be found to intergrade with the Burmese race.

4. Description of a new Dik-dik Antelope (*Madoqua*) discovered in N.E. Africa by Mr. H. S. H. Cavendish. By **OLDFIELD THOMAS, F.Z.S.**

[Received March 22, 1898.]

Among the sporting trophies collected during Mr. H. S. H. Cavendish's recent adventurous journey into the Lake Rudolf region there are a number of skulls, scalps, and body-skins—unfortunately all separated—of the different species of Dik-dik met with during the expedition. The majority of these, as might be expected, are assignable to *M. philipsi* and *M. guentheri*, those being the forms most usually shot by Somali sportsmen.

But one skull and one skin, presumably belonging to each other, are clearly different from the remainder, and indicate a new species of this group. It may be called

MADOQUA CAVENDISHI, sp. n.

Allied to *M. kirkee*, Günth., by the general characters of the skull, by the S-shaped upper outline of the premaxillæ, and therefore no doubt by the presence of a third lobe on the last lower molar, but the lower jaw has unfortunately been lost. Size, however, decidedly larger, so that the new form equals and perhaps exceeds *M. damarensis*, the largest previously known species. The skull is that of a young animal, as the milk-dentition is still in place, but nevertheless its size is just about the same as that of the typical skull of *M. damarensis*, that of an old female. Nasals rather longer in proportion, and decidedly broader, than in *M. kirkee*, also broader than and of rather a different shape to those of *M. damarensis*. Nasal opening very large, conspicuously broader and higher than in either of the allied species. Premaxillæ not touching each other in the middle line above, as they do in the type of *M. damarensis*; posteriorly they reach to the nasals, articulating broadly with the latter.

Horns long and thick, heavily ridged; obliquely oval in section.

In colour, the skin believed to belong to the typical skull is a dark fawn, much darker than in *M. damarensis*, on the anterior back, becoming, by the dying out of the fulvous suffusion, more greyish posteriorly, and quite ashy grey on the sides of the rump. Shoulders, ill-defined line along flanks, and front of limbs sandy rufous. Hairs of crest suffused throughout with dull fulvous.



1.



2.

J. Smut del. et lith.

Mintern Bros. imp.

HEADS OF (1) BURMESE AND (2) JAVAN RACES OF THE BANTING.
(*Bos sondaicus*)



Dimensions of the typical skull, that of an immature male with the milk-dentition still in place:—greatest length 123 mm.; basal length 103·5; greatest breadth 59; nasals, length 22, breadth 22; breadth of nasal opening 17; intertemporal breadth 44·5; breadth of brain-case 47; gnathion to junction of nasals and premaxillæ 37·7; gnathion to orbit 58·5; gnathion to front of alveolus of anterior premolar 28·5; palate, length 60. Length of horn in a straight line 78 mm.; circumference at base 48.

Hab. N. E. Africa—probably the neighbourhood of Lake Rudolf.

Type in the British Museum, collected and presented by Mr. H. S. H. Cavendish. (Should the skull and the skin be wrongly assigned to each other, the skull should be considered as the type.)

Of all the species found in Northern and Eastern Africa, that discovered by Mr. Cavendish is by far the finest, for the typical skull decidedly exceeds that of any of them in size, while it is itself not yet adult. The south-western species, *M. damarensis*, however, is of approximately the same size, although it is difficult to make an exact comparison between the two, owing to the fact that the only available skull of *M. damarensis* belongs to an old female, while that of *M. cavendishi* is an immature male.

For the same reason the specific differences between the two forms are difficult of exact definition, but the darker general colour, the broader and differently-shaped nasals, the higher and more open nasal cavity, and the separated premaxillæ of *M. cavendishi*, combined with the essential difference between the faunas of Damaraland and Lake Rudolf, seem to render it impossible that Mr. Cavendish's Dik-dik should be assigned to the south-western species.

I have named this fine Dik-dik in honour of its discoverer, the first British explorer to cross from Somaliland by Lake Rudolf into our East African territories, and the donor to the national Museum of a number of the specimens obtained during this journey.

April 19th, 1898.

Prof. G. B. HOWES, F.R.S., F.Z.S., in the Chair.

Mr. E. W. L. Holt exhibited some advanced larvæ of the luminous Fish *Scopelus glacialis*, Reinhardt, taken by Dr. G. H. Fowler in the Faroë Channel, and made the following remarks:—

“The larval stages of *Scopelus* have not been described. An almost complete series was obtained by Dr. Fowler. They are remarkable in the possession of a dorsal expansion of the skin, probably functional as a float, which persists until the adult organs of locomotion are practically perfect. Such floats are known in the larvæ of *Gadus* and *Solea*, but only in the very early stages. The specimens of *Scopelus* explain the nature of the dorsal fold of skin in *Anomalopterus*, a genus founded by Vaillant

on what is certainly a larva, the float being collapsed as in some of Dr. Fowler's young *Scopeli*."

On behalf of the Hon. Walter Rothschild, F.Z.S., there was exhibited a fine specimen of the Ribbon-fish, *Regalecus argenteus* (?), which had been mounted by Mr. E. Gerrard, Jr., for the Tring Museum. The specimen had been obtained alive in shallow water, near Dunedin, New Zealand. It measured about 14 feet 10 inches in length.

Mr. Sclater stated that he recently had the pleasure of visiting the small but well-kept Zoological Garden of Marseilles, under the guidance of M. Alfred Weil, the Director. Amongst the animals observed there he had noticed the following of special interest:—

1. A fine adult male of the Leonine Macaque (*Macacus leoninus*), which had been several years in the Collection. It was stated to have been brought from Siam.

2. A not quite adult example of the Korean Sea-Eagle (*Haliaëtus branickii*), in nearly uniform black plumage, with some appearances of white at the base of the tail. Two of these Eagles, of which this was the survivor, had been brought from Séoul and presented to the Collection by a former Secretary of the Russian Embassy to Corea.

3. A pair of Leucoryx Antelopes (*Oryx leucoryx*), recently imported from Senegal. The Society had formerly had many examples of this Antelope in the series, but of late years had not possessed representatives of the species. The Leucoryx was much less seldom brought to Europe now than in former years.

During a short stay at Tunis Mr. Sclater had also, under the kind guidance of Sir Harry Johnston, K.C.B., visited the private collection of living animals belonging to the Bey of Tunis at the palace at Marsa. Amongst the objects noted there were a pair of the Barbary Deer (*Cervus barbarus*), two (apparently) Golden Eagles (*Aquila chrysaëtos*), remarkable for their dark, nearly black plumage, and a single Loder's Gazelle (*Gazella leptoceros*), all stated to have been obtained in the Beylik. There was likewise a stuffed specimen of a young Leucoryx Antelope (*Oryx leucoryx*), originally, it was said, received alive from the south of Tunis¹.

Returning by Paris, Mr. Sclater had passed an afternoon in the Jardin Zoologique d'Acclimatation de Bois du Boulogne, Paris, where he had, as usual, seen much of interest. A single adult male Giraffe of the old stock from the Soudan, born in the Gardens 19 years ago, was still alive there, and apparently in excellent health. In this specimen the third frontal horn was

¹ The former existence of the Oryx in Tunisia is also indicated by some of the Roman mosaics preserved in the Musée Alaoul at the Bardo, among which is an unmistakable figure of a Leucoryx attacked by a Lion.—*P. L. S.*

largely developed. Monsieur Porte had kindly offered, in case it could be arranged, to receive a visit to it of the female now in the Society's Gardens, but Mr. Sclater feared that it would be too risky to advise the transport to Paris and back of such an animal.

Amongst the breeding groups of larger animals in the Jardin d'Acclimatation, Mr. Sclater had specially noticed those of *Cervus davidianus* (3 examples), *Oreas canna* (5 examples), *Cobus unctuosus* (5 examples), and *Oryx leucoryx* (3 examples). Mr. Sclater had also examined with great interest a specimen of a beautiful small Wild Cat from Siam, which was quite new to him. It was labelled *Felis minuta*, but was certainly quite different from *Felis javensis* as figured by Elliot ('Felidæ,' plate xxviii.), under which name Mr. Elliot had placed *Felis minuta* of Temminck as a synonym.

The following papers were read:—

1. On the Breeding of the Dragonet (*Callionymus lyra*) in the Marine Biological Association's Aquarium at Plymouth; with a preliminary account of the Elements, and some remarks on the significance of the Sexual Dimorphism. By ERNEST W. L. HOLT.

[Received April 18, 1898.]

(Plate XXVI.)

CONTENTS.

- I. Introductory and Historical, p. 281.
- II. Secondary Sexual Characters, p. 233.
- III. Courtship and Pairing, p. 286.
- IV. Employment of the Secondary Sexual Characters for purposes not connected with Reproduction, p. 294.
- V. Preliminary Discussion of the Colour-Mechanism and Differentiation of Coloration, p. 297.
- VI. The Soluble Pigment and the Palatability, p. 305.
- VII. General Considerations, p. 311.

I. *Introductory and Historical.*

So far as I am aware the Dragonet furnishes, among Teleostean fishes propagating by pelagic ova, the only known instance of a definite sexual intercourse. Since Savile Kent's account of the pairing appeared rather meagre, I considered it desirable to make further observations, and, with this end in view, commenced to collect as many large specimens as possible in the autumn of 1897. Experience with other marine forms had shown the necessity of acclimatizing the fish to tank life some considerable time before the breeding-season. The Dragonet, locally known as the Sting-

fish or Miller's Thumb, is one of the commonest fish in the Plymouth district, and commences to spawn there, as has been shown by Mr. S. D. Scott and myself¹, in the first month of the year.

A number of females and small undifferentiated males were successfully acclimatized in the autumn and early winter, but no large differentiated males survived. However, two fine specimens were brought in in January, and at once took kindly to their new surroundings. When these males were placed in the tank a female was observed to watch their movements with evident interest. As frequently happens, they spent a considerable time in swimming about the surface of the tank before descending. The female meanwhile swam about at the bottom, following now the movements of one male, now of the other. When one finally descended, the female approached and appeared to smell him. Her curiosity thus satisfied, she took no further notice of him.

I had occasion to be absent from the Laboratory for about a fortnight, ending on the 10th February. No signs of sexual activity were previously observed, and Mr. Smith, the chief Laboratory attendant, who was kind enough to keep watch on the proceedings of the Dragonets during my absence, saw nothing unusual in their behaviour. On the 11th February I found pairing in full progress; but, before giving the results of my own observations, I propose to quote the account given by Savile Kent, who, I believe, is the only writer who has dealt with the subject:—

“The male, resplendent in his bridal livery, swims leisurely round the female, who is reclining quietly on the sand, his opercula distended, his glittering dorsal fins erect, and his every effort being concentrated upon the endeavour to attract the attention and fascinate the affections of his mate The female, at first indifferent, becomes at length evidently dazzled by his resplendent attire and the persistency of his wooing. She rises to meet him, the pair—so far as is practicable with fishes—rush into each other's arms, and with their ventral areas closely applied ascend perpendicularly towards the surface of the water. In connection with these manoeuvres it may safely be predicted that the ova are extruded and fertilized, but in the limited depth of water of an aquarium tank the matrimonial tour cannot, apparently, be sufficiently prolonged to ensure the consummation of this act; the fish, after reaching the surface, being projected by their previously gained impetus slightly above it, when, falling apart, they sink slowly to the bottom, and the process, after short intervals, is repeated. It is, however, by no means impossible nor even improbable that the fertilization of the eggs in *Callionymus* may take place while the fish are above the surface of the water, as has actually been recorded by Alexander Stenzel in the Nase or Zupe, *Chondrostoma nasus*.” (Savile Kent, Handbk. Gt. Intern. Fish Exhib. Lond., i. 1883, p. 128.)

¹ Holt and Scott, Journ. M. B. A., n. s., v. p. 156, 1898.

In connection with the preceding remarks, and also in 'Nature' (viii. 1873, p. 264), the author draws a comparison between the secondary characters and courting behaviour of the male *Callionymus* and those of birds, which has been dignified by a reference in Darwin's 'Descent of Man.' With regard to his account of the pairing, it appears to be of a popular character, and, as the subject is rather a delicate one, any criticism of its inadequacy would be ungracious. If, however, I may judge from my own experience, the account is so inaccurate in some details of importance as to warrant a full redescription.

II. *Secondary Sexual Characters.*

It is now matter of common knowledge that, while young Dragonets of either sex closely resemble each other both in colour and conformation¹, the male acquires, as its size increases, very well-marked secondary sexual characters. It will be convenient to briefly recapitulate the most striking differences, since these will be found to play an important part in the behaviour of the two sexes when pairing.

In the female, throughout life the first dorsal fin is very short. The second dorsal and the anal are of moderate proportions, their posterior rays not being produced in such a manner as to reach the caudal fin when depressed. The proportions of the head undergo no marked metamorphosis. The genital aperture is at no time produced into an elongated papilla. The colours of the dorsal surface are brown or reddish brown, barred and mottled with lighter and darker markings, and closely resembling the bottom on which the fish may be resting. In young examples on bright gravel the general colour may be diversified with purple, green, and crimson. The ventral surface is devoid of pigment.

The male, on the contrary, acquires with growth a more elongated snout. The first dorsal fin becomes greatly elongated. The second dorsal and the anal increase in size, especially their posterior rays, which ultimately reach, when depressed, beyond the origin of the caudal fin. There is a distinct genital papilla, visible even in specimens only two inches in length, and conspicuously elongated in large fish. The metamorphosis of the head and fins appears to be of a gradual nature, though perhaps more rapidly accomplished during the later period of growth. It is not constantly related, in its ulterior development, to a fixed size, nor to the attainment of sexual maturity.

Pari passu with these structural differentiations appears a striking change in the coloration. While the back retains the marbled brown markings, the front and sides of the head, the sides of the trunk, and the pelvic, dorsal, and caudal fins become decorated with yellow and blue bands. I need not particularize these since the drawing exhibited (Plate XXVI.) gives an accurate representation

¹ Inconspicuous differences exist from an early age (Fries, *cf.* Smitt, *Hist. Scand. Fish.* ed. 2, i. p. 277).

of a fully mature male, such individual differences as are met with in the number and distribution of the bands being of no importance here. The bands of the first dorsal are less frequently a pale blue, the colour manifesting itself rather often in the detached markings near the base of the fin. The eye, reddish brown or cupreous in females and young males, becomes in large breeding males of a brilliant metallic blue-green, most readily comparable to the palest tint present in the ocellus of a peacock's "tail" feather. On the ventral surface the throat, the underside of the pelvics, and the anal fin become adorned with black pigment, the anal occasionally showing an additional bluish tinge.

The colour-change of the eye appears to be of a seasonal character. The other changes are of a more permanent nature, though the brilliant coloration shown in the drawing (Plate XXVI.), especially in so far as regards the yellow bands of the body, is of comparatively brief seasonal duration. As in the case of the structural characters, the full development of the coloration-change is not necessarily achieved before the fish is fully mature. Thus Dr. G. Johnston (Zool. Journ. iii. p. 336) records a "Sordid"¹ Dragonet with milt, and Mr. G. A. Boulenger has shown me a male, with ripe milt, in which the secondary characters are only slightly developed².

This is by no means surprising, since males of *Arnoglossus laterna*³ and *Coris julis*⁴, which, as I believe, undergo a sexual dimorphism exactly parallel to that of *Callionymus*, are frequently mature in the undifferentiated livery. It is, I suppose, unnecessary to adduce instances among the higher animals in which the sexual maturity of the male is accomplished before the full development of the secondary differentiations.

The smallest sexually mature male Dragonet which has come under my notice measures 16 cm. ($6\frac{1}{4}$ inches). The extremity of the first dorsal ray reaches the base of the seventh ray of the second dorsal fin. The blue and yellow coloration is present, but the yellow especially is much less brilliant than that of large males taken at the same time. There is very little black pigment on the throat, and only the hinder rays of the anal are somewhat dark. The testes are small, but contain many advanced and a

¹ It is perhaps unnecessary to state that the Sordid Dragonet, *C. dracunculus*, comprising females and undifferentiated males, was once held to be distinct from the Gemmeous Dragonet, *C. lyra*; the latter term being reserved for fully-developed males.

² Day (Fish. Gt. Brit. i. p. 176) quotes an observation of the Rev. G. Harris, who stated that he had found hard roe in a "Gemmeous" Dragonet. I can only associate myself with the compiler's comment that this observation is interesting, if correct.

³ Cf. Cunningham, Proc. Zool. Soc. 1890, p. 540; Holt and Calderwood, Sci. Trans. R. Dub. Soc. ser. ii. v. 1895, p. 488.

⁴ The specific identity of *C. julis* and *C. giofredi* has been denied by Gourret in the most positive manner (Ann. Mus. Mars. iv. 1893, no. 3). I have re-examined the question at Marseilles, where Gourret's material was procured, and can find no support for his conclusions. A note dealing with the subject is now in the press (Ann. Mus. Mars., ser. 2, Bulletin i.).

few ripe and active spermatozoa. Another male, taken in company with the last, is 15.4 cm. ($6\frac{1}{8}$ in.) in length. In structural differentiation it is nearly as advanced as the last, the first dorsal ray reaching the fourth of the second dorsal fin; but the coloration differs from that of two females of about the same length only in that the dark spot of the first dorsal is bounded anteriorly by the third instead of the second ray, a more or less constant sexual distinction. In this male the testes contain no advanced spermatozoa. It would appear, therefore, that the coloration is more intimately associated with the maturity of the genital organs than is the structural differentiation.

Another sexually immature male, 18.3 cm. ($7\frac{3}{16}$ in.) long, supports the same conclusion. The coloration is quite undifferentiated, though the first dorsal ray nearly reaches the eighth of the second dorsal. The variation of size in relation to sexual maturity is in no way remarkable.

Smitt (Hist. Scand. Fish. ed. 2, i. p. 273) notes that the male, which reaches a length of 30 cm., is much larger than the female. The latter has not been observed, by Scandinavian naturalists, to reach 25 cm.¹ This statement is in general accordance with my own experience of the species. As a matter of fact the difference in size, among the larger specimens, is to some extent due to the greater length of the snout and caudal fin in the male. Thus a male and female measure respectively 24 and 21.7 cm., but in regard to the distance from the front of the eye to the origin of the caudal fin are of exactly the same length.

In the mature condition, at all events, males appear to be much more abundant than females. On two occasions a trawler has brought me what purported to be his whole catch of Dragonets. In one catch there were 95 males and 21 females, in another 72 males and 1 female. The actual proportions may be to some extent obscured by the smaller females escaping through the meshes or being overlooked by the fishermen, but the great discrepancy cannot be altogether accounted for in this way, and a general preponderance of males is borne out by my own trawling experience. A similar numerical proportion of the sexes obtains, as first pointed out by Cunningham, in *Arnoglossus laterna*, at least among the large specimens on the offshore grounds. Here also the male is the larger fish. Among Teleosteans the female is nearly always the larger and the more abundant sex. The relations of size are here reversed, and, if food competition severely taxes the weaker individuals, it is not unnatural that the relations of number should conform. Without the necessity of supposing (without proof) that the feebler members are actually starved out in the early stages of life-history, we arrive at the same result if we allow that sex is largely influenced by nutrition. It would appear that a plentiful nutrition favours the production of female individuals. In the case of *Callionymus*, if the sex is determined,

¹ The smallest ripe female which I have seen measured 16.8 cm. ($6\frac{5}{8}$ in.). A specimen of 14.2 cm. was very nearly ripe.

as Stolzmann considers in birds¹, by ovarian nutrition, it is obvious that the conditions are decidedly adverse to a preponderance of female offspring. Among insects it is known that sex is, or in some cases may be, determined by the nutrition of the larva. It is difficult to believe that this is the case in Teleostean fishes, since we might expect that the female sex would invariably preponderate in size and number. Valuable information might accrue from the experimental feeding of salmon or trout larvæ; our present control of marine forms, and especially of such as propagate by minute pelagic eggs, does not promise much in this field of research.

Although the subject does not concern the sexual dimorphism, a few words are necessary on the position of the eyes in order to explain my figures. In dead specimens the eyes are sunk into the sockets and scarcely project above the general level of the top of the head. They are faithfully presented in such condition in all the figures of *C. lyra* which I have seen. In life, however, the eyes project boldly above the cephalic contour as indicated in my figure 1². They are not retracted on alarm, but only when the fish has buried itself in the sand or gravel. Retraction is evidently effected by the eye-muscles. Protraction must be ascribed to the elasticity of the membranous wall of the orbit and of a large but very delicate *recessus orbitalis*³. This structure communicates with the membranous cavity, as may be demonstrated by injections, below the centre of the eye. It is so thin-walled that I have not found it possible to make satisfactory dissections. Lying for the most part immediately under the skin, externally to the eye, it dips anteriorly below the spatulate part of the great lachrymal scute. Posteriorly it approaches the base of the preopercular trident. In its lateral region it appears broken up into a great number of minute chambers into which the injected fluid does not readily pass. I must acknowledge the assistance of my friend Mr. L. W. Byrne in tracing out this organ. At present our results do not justify a more detailed description.

III. *Courtship and Pairing.*

The Dragonets inhabit a glass-fronted tank, about four feet deep, on the south side of the aquarium. The sides are painted white and the bottom is covered with fine light gravel.

The other inhabitants of the tank are a number of grey mullet, two red mullet, a small bass, some rockling, and sundry crabs and hermits, the latter with their associated anemones, *Adamsia rondeletii* and *A. palliata*.

In February there were two large male Dragonets, with fully-

¹ I must acknowledge my indebtedness to Mr. F. E. Beddard's 'Animal Coloration,' Lond., 1892, p. 277, &c.

² Probably some approach to the natural condition is shown by Richardson, in his figure of *C. reevesii* (*C. longicaudatus*, Temm. & Schleg.) in Voy. Sulph., Fish, pl. 36. fig. 1.

³ Cf. P. Z. S. 1894, p. 422.

developed secondary characters. One of these was found to measure 24.75 cm. ($9\frac{3}{4}$ inches). The other appeared to be almost exactly the same size. A female, one of the largest, was 17.15 cm. ($6\frac{3}{4}$ inches) long. There were also a number of fish of about the same size and smaller, including both females and young males.

Previous to the 11th February the Dragonets were sluggish in disposition, frequently burying themselves in the gravel, though active enough at feeding-time. The large males were not observed to display their dorsal fins, though young fish will often raise the first dorsal. The colours of the large males, so far as they could be seen, were not remarkably brilliant.

Entering the aquarium at about 9 A.M. on the morning of the 11th February, I noticed a pair of Dragonets ascending together to the surface of the tank, and found, on observation, that pairing was in full progress. The operation was repeated every day until the 19th February, so that I had ample opportunity of noting the details, which I shall attempt to describe.

While pairing is in progress all the Dragonets in the tank appear to be in a state of great excitement, especially the two large males. These keep darting along the bottom of the tank at short intervals, at the same time exhibiting all their finery. Sometimes the dorsal fins are erected before the fish starts, oftener at the instant of starting, while the mouth is protruded to its utmost, causing the roof of the groove which lodges the ethmoid process of the premaxillæ to be raised nearly or quite to the level of the top of the eyes. The gill-covers are inflated and the hyoid apparatus is depressed, while the pelvic fins are held rigidly forward and outward. The attitude is well shown in my sister's drawing (Plate XXVI.)¹. The fish scarcely leaves the bottom, the anal fins remaining depressed and out of sight. The motive power is furnished by the pectoral and caudal fins, sometimes by a stroke of the whole tail. The yellow bands are much more brilliant than they were noticed to be before sexual activity commenced. They undergo no change with the elevation of the fins, but retain their extreme brilliance only for the first few days. The blue bands of the side flash out with intense brilliance as the fins are hoisted, but become paler again before they are lowered. This vividness of colour is attained only during the first few days of sexual activity.

The blue bands of the head are but little, and those of the pelvic fin not at all affected when the dorsals are raised. The bands of the latter never attain the same depth of colour as those of the side. Their colour is rather that of a turquoise, while

¹ Van Wright's figure (H. Smitt, *Hist. Scand. Fish.* ed. 2, pl. xiv.) was painted from life, but the depressed condition of the eyes and the position of the pelvic and anal fins suggest that the outline was taken from a dead specimen artificially arranged. My sister's drawing is a compilation of sketches from life, checked by measurements of a dead specimen of about the same size as the living model.

those of the side approach the deep lustre of a sapphire. I think that the drawing (Plate XXVI.) gives a faithful representation of the colours in their most intense development. These manifestations occupy but a very short time. The whole mouth-apparatus being engaged, it follows that the attitude cannot be maintained beyond the interval of a single respiration. As a rule the mouth is partly retracted and the fins lowered for a time at the end of the respiratory period, but sometimes respiration takes place without the lowering of the fins.

The male fish appears to make its advances in rather a promiscuous manner. Although the Dragonet is keen-sighted and apparently depends chiefly on its eyesight for obtaining food, the male does not seem to be able to see or find the female unless she is quite near him. He darts about, as it appears to me, frequently without any particular object. If other Dragonets, females or young males, are near, he darts at them, driving them off in precipitate flight. My observations lead me to the belief that the courting male cannot distinguish either between females and young males, or between ripe and unripe females except by their response to his advances. Occasionally the two males meet in full splendour. Then one lowers his colours and flies ingloriously; but I have seldom seen anything in the shape of a fight, and have never found wounds that might have been inflicted when I was not watching.

Quite often the male makes a dart when no other fish at all is near, or rushes among the mullet, who are by no means interested in his demonstrations. It may be supposed that on these occasions he is merely advertising his whereabouts to any female that may see him, since he is a conspicuous object, while she is not. When not moving about, the male elevates his head by means of the pelvic fins and moves his eyes in all possible directions, and does not fully retract the protrusible jaw-apparatus until active operations are suspended.

Of the females present in the tank only one, which proved to measure 17.15 cm. ($6\frac{3}{4}$ inches), was on this occasion in breeding order. She makes no demonstrations of a very marked nature, now resting poised on her pelvic fins, now swimming from one part of the tank to another. Her dorsal fins are not raised, and indeed they would not make her much more conspicuous. Now and then a male approaches her and evidently recognizes, perhaps only from her response to his advance, her sex and condition. He proceeds to glide past or circle in front of her, sometimes resting still in front of her with all his bravery displayed. If the two males both approach her at the same time, one is soon put to flight, as we have seen, by what usually appears to be simply a battle of millinery. But, as we shall see later, I have particularly noticed that the spoils are not always to the victor.

Acceptance is denoted by the female swimming to the side of the male, who, as a rule, instantly lowers his fins and retracts his jaws and gill-covers. The two then swim slowly side by side

along the bottom, the female converging on the male. When the two are close together the male gradually raises the fore part of his body off the bottom by the action of his pectorals, at the same time elevating the hind part of his second dorsal and anal. The female, whose pelvis are rigidly expanded, places one of them on that of the male, and squeezes herself snugly into the hollow between his gill-cover and pectoral and pelvic fins. Meanwhile her second dorsal and anal are rigidly erected. The process at this stage is shown in the sketch (fig. 1, p. 289). It is impossible to resist the simile of a lady taking a gentleman's arm.

Fig. 1.

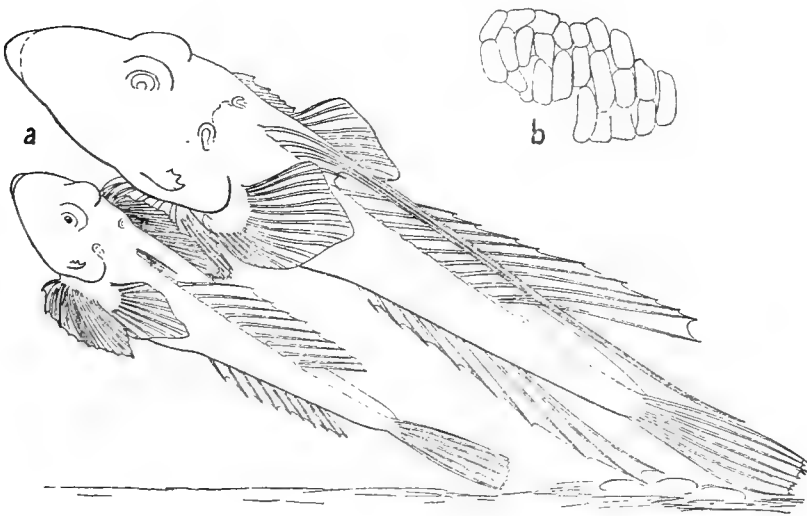

a. Male and female Dragonets preparing to ascend. Reduced three-fifths.
b. Bundle of prismatic bodies. Magnified.

The female once in position, a result which is attained by the action of her pectorals and sometimes her caudal, the male slowly raises himself, and her, to an almost vertical position, and the matrimonial tour, as Savile Kent terms it, commences. So far as I can see, the male actually carries the female up, since her body is held rigidly straight and the movements of her pectorals and, occasionally, of her caudal seem mostly devoted to maintaining herself in position. In ascending the male uses chiefly his pectorals, aided by the caudal and the hinder parts of the second dorsal and anal. I owe to Mr. J. T. Cunningham the suggestion that this function explains why these fins are more elongated, especially in the hinder region, than those of the female. As for the first dorsal, that is evidently for show and not for use; it is kept out of the way, flat on the back.

Once well clear of the bottom, the pair soon assume an absolutely vertical position, and the male, by a sinuous flexure of his trunk, brings his side, for some part of its length, in contact with that of the female, at the same time turning the front part of his anal towards her, and pointing his now elongated genital papilla in the same direction. The female becomes slightly inclined towards him, so that the edges of their anal fins are in contact for some distance. A funnel is thus formed, and, as I suppose, the ova are shot down it from the backwardly-directed genital aperture and fertilized *en passant*, a process which is assisted by the gentle fanning of the first few anal rays of the male. The relations of the pair are shown in the drawing (fig. 2, p. 290). There is, and,

Fig. 2.

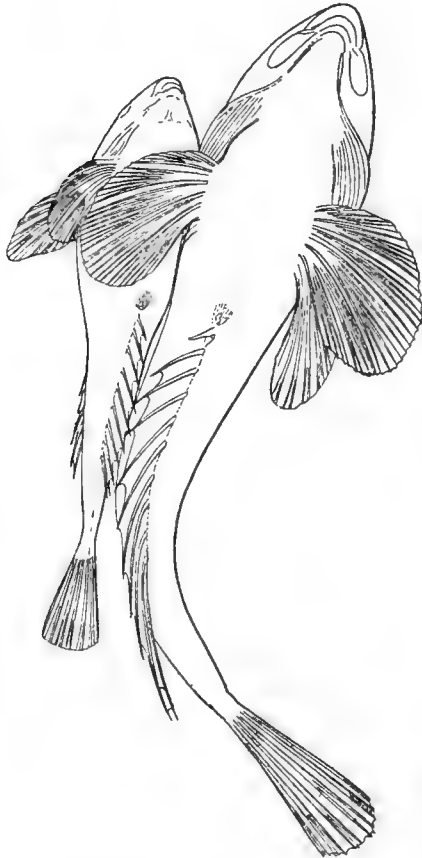

Male and female Dragonets in coition. Reduced three-fifths.

from the anatomy of the participators, can be no such apposition of the ventral surfaces as is described by Savile Kent, since such would certainly involve the female quitting her position at the base of the

male's pelvic fin and so losing her hold on his person if not on his affections. As the tank is only four feet deep the pair naturally reach the surface soon, though the upward progress is very slow, since the male, who has most of the work to do, is much hampered by the impossibility of using the tail, his principal organ of locomotion when unhampered by female society. Arrived at the surface the pair occasionally come apart, but more usually continue together, their snouts bobbing in and out of the water, while they wander vaguely about, still endeavouring to ascend¹. In process of time they lose hold of each other and dart rapidly to the bottom. Sometimes the male, more rarely the female, seems unaware of his or her loss and continues to cruise futilely at the surface. Occasionally one or the other will ascend to the surface alone, so that it is possible that the female assists in the ascent (when the two are together), though I certainly think that she is more concerned in sticking to her partner. The superior size of the male is no doubt of importance.

I cannot positively say that I saw ova extruded. They are very small and practically transparent, and difficult enough to see even under the most favourable circumstances in a tank. It is my impression that I saw them on one occasion. Milt was not extruded by the male in visible quantities, but the milky fluid common to many fishes is not always found in connection with ripe spermatozoa. In any case ova were extruded and fertilized, since they appeared in a net fixed on the overflow port of the tank, and duly hatched out in the jars in which they were placed. Evidently the limited depth of the tank is not, as Savile Kent supposed, a bar to the successful accomplishment of the matrimonial enterprise.

I was able to ascertain that the female takes sometimes the right, sometimes the left pelvic of the male, but whether by accident or design I cannot say. In the ripe condition the ovaries cause a very conspicuous bulge on either side of the posterior part of the abdomen, and it may be that the close apposition of the sides of the male and female assists the latter in the extrusion of the products of whichever ovary is thus subjected to pressure².

The first period of reproductive activity lasted, as we have seen, for eight days, commencing, as first observed, on the 11th February. The activity was greatest for the first few days, and the full splendour of the male was only attained during about three or four days. Only one female was engaged. Pairing was observed to take place from 9 A.M. to about 11 A.M. or noon. After this the males ceased to sport and usually buried themselves in the

¹ There is no evidence to show how far the ascent is continued under natural circumstances, but a male has been recorded by Matthias Dunn (in Day's Fish. Gt. Brit. i. p. 176) from a mackerel-net at the surface of 40 fathoms in May. Some examples are still breeding in this month. The species has been taken at a maximum depth of 218 fathoms.

² In *Mallotus villosus*, a species propagating by demersal eggs, "two males, one on each side, hold the female, while she rushes with great swiftness on the sandy beach and there deposits her spawn" ('Descent of Man,' p. 331).

gravel. At about 4 P.M. activity recommenced, but in a much less degree. No pairing was observed in the evening, at night, or very early in the morning.

The notes have chiefly been drawn from this period. With a view to further observations I collected as many living Dragonets, of mature size, as possible, and placed them in the tank. All fish of other species, except the rockling, were removed, as they were constantly getting in the way and obscuring the view.

Dragonets are very delicate fish, and large ones are especially difficult to bring in in good condition, since, if they do not die on the way, they often succumb very shortly to injuries they may have received in the net. The caudal fin is particularly liable to abrasion, which almost always proves fatal, the fin sloughing away and the fish dying within a few days. A number of fish were brought in, comprising but a few females, and I believe that all the latter died. I wished to observe the behaviour of a large female, about 23 cm. in length. She appeared fully ripe and was assiduously courted by the males, but made no response, and succumbed in the usual way to injury of the caudal fin.

Pairing was again observed on the 8th March, and continued, somewhat intermittently, for about ten days. Only one female was engaged, and, if not the same individual as paired in the previous month, she was of about the same length, and therefore greatly inferior in size to her partners. There were five males with fully-developed sexual characters, including the two which took part in the proceedings of the previous month. None were in very brilliant colour, and one in particular, belonging, I think, to the original stock, had practically lost all the brilliant yellow of the body-bands. On the 12th March I spent some time in watching the pairing-operations, wishing to obtain some knowledge of the selective proclivities of the female. I shall call the males A, B, C, D, and E. A and B are large; C and D are rather smaller, but as well furnished, both as to colour and differentiation of fins; E is large, but dull in colour. The female may be called G.

A and G ascend together, and come down, quite near each other and near B. B immediately approaches G, and exhibits himself several times to her, just in front of A, who lies still, breathing rather rapidly but making no sign. G accepts B's attention and they are about to ascend, when they lose hold and separate. They very shortly adjust matters and start again. Just as they are leaving the bottom, A rouses himself, and, setting up his fins, darts under them, sweeping their bellies with his first dorsal. They are not disturbed and consummate their tour. In descending G swims off to the neighbourhood of D. I did not see B engaged again on that morning.

Subsequently A and G are about to ascend, when C, who is much smaller than A, approaches and makes demonstrations. A leaves G and sets his fins at C. A few counter-demonstrations ensue, until, when both are in full array, A suddenly darts above

C, striking the first dorsal of the latter about halfway up with his head. The movement is very rapid, the object being, apparently, to strike C's fin with the teeth, which project when the snout is fully protracted. No damage whatever is inflicted, but C runs away. This attack was repeated on another occasion, and appears to be the nearest approach to a fight that ever takes place. In spite of the discomfiture of C, G continued to ascend alternately with the conqueror and the conquered for the rest of the time that I was watching them. I did not see her in the neighbourhood of D. B was quiet after the ascent noted. E, the large dull-coloured fish, made no demonstrations, and seemed only concerned to get out of the way of such males as approached him with fins erect. He finally buried himself in the gravel.

It is difficult to decide, from the above observations, that superior size and strength are of much avail to the male. A, though he defeated C, got no more of G's society than his rival, while B carried her off under his very nose. The system appears, in fact, to be simply promiscuous polyandry, the female coupling with the nearest male who is in a condition to further her object. Among a lot of individual males, including some which are sexually mature but neither very large nor thoroughly differentiated, I imagine that the demonstrations of the large fully-differentiated specimens would achieve the result of driving the smaller and less ornate members from the field; but, among themselves, fully mature males seem to attain no individual advantage, and the female does not care a rap with whom she pairs. However, her involuntary selection of any fully mature male (the small semi-differentiated ones being driven away) must tend to the advantage of the species, if the influence of the male parent is of importance in determining the size and vigour of the offspring.

Savile Kent has compared the courting antics of the male Dragonet to those of the cock in certain of the pheasants. In the main the comparison seems just, though the Dragonet often exhibits his charms in a purely speculative manner, on the chance, as I suppose, of attracting a partner unseen to himself, but of whose presence, somewhere in the vicinity, he is presumably aware. Under similar circumstances the cock pheasant, perhaps, would exert his vocal accomplishments, such as they are. Although we have had mature male Dragonets in the tanks at practically all times of the year, I have never seen them in the full courting attitude except during the breeding-season. Moreover, some mature males kept for a time during the breeding-season in a tank by themselves were not observed to show any signs of sexual excitement, although the maturity of their reproductive organs was demonstrated by their behaviour when transferred to the tank containing the ripe female. It must be a matter of general experience that the domestic barn-door cock "scratches his wing" to younger members of his own sex in a manner exactly similar to that which he employs in endearing himself to the hen which he designs to favour. The old cock can undoubtedly distinguish a

cockerel from a pullet by sight alone. I doubt whether a big male Dragonet has the same power of discrimination with regard to his own species. His demonstrations to young males or unripe females are precisely similar to those which are directed to the mature female, and the result is the same as in the case of poultry—viz., the younger members flee in evident alarm.

IV. *Employment of the Secondary Sexual Characters for purposes not connected with Reproduction.*

During and after the breeding-season the males have been observed to make use of their elongated dorsal fins for purposes quite unconnected with sexual intercourse. I can neither affirm nor deny that their habits are the same at all seasons. After the mullet had been removed from the tank it was first noticed by Mr. Smith (and confirmed by frequent observations of my own) that the mature males elevate their first dorsals in rushing at worms (*Nereis* and *Arenicola*) dropped into the tank. When a bunch of worms is dropped in, all the Dragonets, if not recently fed, assemble to partake. The young ones are always the first on the scene, but the advent of a large male, with dorsals extended, is sufficient to scatter them. It is reasonable to suppose that the display is intended to achieve this object. It is exhibited indifferently by brilliant males and by those whose coloration has decidedly faded. I do not think it unlikely that the fins are displayed with this intent at all seasons; the circumstances have not at other times been so favourable for observation.

Mature males when recently introduced into the aquarium do not display the dorsals, except in the most momentary fashion, when chased about the tank with a net; but when they have remained in a tank for some days undisturbed, the approach of the net is sufficient to ensure the dorsals being fully displayed, and for a period more protracted than I ever observed during courtship. Continued persecution causes momentary intensification of the blue bands of the side, even when the yellow bands have largely faded. The fish, in fact, continues to freely exhibit his secondary characters until he succeeds in darting into a dark corner or burying himself in the gravel. One can hardly hesitate to believe that the fins are hoisted and the colours displayed with a view to the intimidation of the intruder. There is a practical difficulty in the way of testing the truth of this supposition by the behaviour of the Dragonet in the presence of a predaceous fish. To transfer either the one or the other to a strange tank is not a fair test, and this must be borne in mind in considering the conclusions to be drawn from the experiments which I have made.

On the north side of the aquarium is a very large tank, the further recesses of which are shrouded in obscurity. It is the dwelling-place of sundry conger, dog-fish, skate, wrasses, &c., and, in particular, of a number of large turbot, which last are in the enjoyment of excellent appetites. On several occasions during

the breeding-season of the Dragonets, I endeavoured, with the assistance of my friend Mr. F. Gover, to observe the behaviour of large males when dropped into the presence of the turbot. However, the former invariably managed to reach a dark corner before the turbot became aware of their presence, and we never saw them again. They may be there still, since there are many small fish, wrasses of several species, in the recesses of the tank, which do not show themselves at the front once in a month. On another occasion a similar experiment, with more fortunate result, was made by Mr. E. J. Allen, Director of the Laboratory, and myself. We succeeded in making a large male Dragonet, brilliantly coloured, swim over the part of the tank frequented by the turbot. One of the latter started in pursuit, and the Dragonet bolted at full speed, *with dorsal fins depressed*, but was caught and engulfed. No sort of effort was made to display the colours. Here the Dragonet was on strange ground and the turbot at home.

After pairing had ceased and the colours of the male Dragonets had greatly faded I placed a large turbot in their tank. As the big fish descended to the bottom the Dragonets, large and small, darted wildly away, and some buried themselves in the gravel. The turbot appeared only concerned to get out of the tank, which is much better lighted than the one in which it has spent the last few years. It paid no attention to the Dragonets, but kept swimming backwards and forwards along the bottom, generally close to the glass. Whenever it approached a large male Dragonet the latter would put up his dorsals and dart out of the way, not very rapidly. Once the turbot came to rest opposite a corner in which was a large male Dragonet, who erected his dorsal fins and slowly glided past the intruder. As long as the turbot was left in the tank the Dragonets seemed uneasy and kept moving about, but they did not display their fins unless the turbot was quite near them. One got out of harm's way by clinging to the side of the tank by the pelvic fins, which, as is well known, are capable of acting as a sucker (as in *Gobius*), though not very often used in this way. Here the Dragonets were at home, and were not actually attacked by the turbot, whose attention was distracted by his unwonted surroundings. I think it is clear that the male Dragonet does display his fins to intimidate a possible enemy, but it is impossible to say to what extent he relies on the efficacy of the exhibition should the enemy actually attack him. As a matter of fact, fully-developed male Dragonets are, under natural conditions, frequent victims to predaceous fishes; but this question may be discussed more conveniently at a later stage.

Small Dragonets, whether male or female, have also been observed to erect one or both dorsal fins at the approach of a large fish or a net, always provided that they have been in the tank for some time. While catching specimens in the various table-tanks in which they have been kept, I have often noticed that small Dragonets will hoist the first dorsal fin at the approach of the net; sometimes they remain still for a time, waving the

fin from side to side. In females and undifferentiated males the hind part of the fin is occupied by a dark marking which sometimes takes the form of an intense black spot extending over nearly half the fin. It is my impression that the individuals with the darkest fins are more prone to display than their paler brethren, but I should not like to insist on the correctness of this observation¹. In table-tanks a momentary elevation of the pale second dorsal is difficult to detect. I therefore made (on the 11th April) some experiments in the deep aquarium tank with a view to more satisfactory observation of this point. A half-grown Tub Gurnard (*Trigla hirundo*) and an Angel (*Rhina squatina*) were successively introduced into the Dragonet tank. I was able to satisfy myself that on the near approach of either of these fish the young Dragonets sometimes elevated both dorsal fins. The elevation of the second was always of very short duration, and in some cases only partial. Some of the specimens seemed content to rely entirely on their resemblance to the gravel (as I have also noticed in catching them), and did not hoist their fins at all. One specimen, which made violent endeavours to leap out of the tank on the approach of the gurnard, was, and remained for some time, unusually pale after returning to the bottom. A similar change of colour was pointed out to me by Mr. F. W. Gamble in one of two young specimens taken from the table-tank on the same day. The emotion of terror appeared in both cases the most probable stimulus. As contrasted with the large differentiated males small Dragonets certainly display their fins, in the presence of danger, much less invariably. On one occasion, the intruder being a turbot, it was observed that a young Dragonet, near which the turbot had settled, erected the fore part of its body by a vertical depression of the pelvic fins and remained in this attitude until the turbot went away. The Dragonet was not on the gravel, but on a white ledge of the side of the tank. The attitude may possibly have been intended to enhance its apparent size, or may have been merely a preliminary to flight, if attacked. The dorsal fins were not erected.

It is noteworthy that large males, when threatened, do not assume the full courting attitude. The cheeks may be puffed out, but the jaws are never protracted to the full extent, and sometimes not at all. The preopercular tridents can be thrust out free of the sides of the head at will; but I have never seen this done in the water, unless the fish were actually seized. It will then strike with its head from side to side.

¹ Poulton ('Colours of Animals,' p. 166) has quoted a suggestion of Mr. Garstang's to the effect that the black first dorsal of the Weever (*Trachinus vipera*) may subserve the function of a warning signal. It has been suggested by Cunningham (Journ. M. B. A., n. s. vol. i., 1889, p. 37) that the Dragonets and Weevers are allied forms. Apart from the question of affinity, there is the obvious suggestion of mimicry, on the part of the non-poisonous Dragonet, of the really formidable Weever, but some further investigation of the habit and habitat of the two forms seems indispensable to a profitable discussion of this question.

Though differentiated males exhibit their dorsals, and especially the second, much more readily than other members of their species, they by no means neglect an opportunity to escape observation. Thus I have several times seen a male, approached by a dangerous intruder, remain quite still except for the movements of the eyes. If the enemy showed signs of approaching too near, the Dragonet would stir slightly and even commence to raise its fins, but these were at once dropped again when it appeared that the enemy was about to pass on. This happened after the breeding-season, when the male Dragonets were by no means conspicuous when at rest.

V. *Preliminary Discussion of the Colour-Mechanism and Differentiation of Coloration.*

It is known that in birds the sexual differences of coloration, though often very striking, are not due to the presence in one sex of any pigment that is not present in the other. The diverse effects result from differences in the texture of the feathers, involving diverse conditions of interruption of the pigment (cf. Beddard, 'Animal Coloration,' p. 4). As might be supposed, the same pigments are present in both sexes of *Callionymus*. They consist of a yellow, probably a lipochrome, and a black, which may be presumed to be melanin. The researches of various observers have shown that the elements which contribute to the coloration of the Teleostean skin are (i.) pigments, whether contained in chromatophores or partially diffused, (ii.) a reflecting substance, distributed in a variable manner and found to consist, in cases that have been investigated, either of guanin or "guanin-kalk," a combination of the former with lime. Isolated crystals of calcium phosphate have been detected in some forms, while hæmoglobin in the underlying muscles is an occasional contributor to the superficial coloration. It will be readily understood that variation in the distribution of yellow and black pigments alone may produce in different parts of the skin a range of coloration from pure yellow through brown to black, while manipulation by expansion or contraction of individual chromatophores may give rise to the well-known "protective" changes common to most of the bottom-living fishes¹. Such changes occur in the female and young male of *Callionymus* and in the parts of the adult male which are not affected by the sexual differentiation, but need not concern us here. Both the pigments and the reflecting substances present in many fishes have received a certain amount of attention by various authors. The reflecting substance in *Alburnus* and *Argentina* has been shown to consist of guanin². The brilliance of the iris in certain forms has been traced to the optical properties

¹ Cf. Agassiz, "Development of the Flounders," Proc. Amer. Acad. xiv. 1878, p. 14, pl. viii.; Cunningham, 'The Common Sole,' 1890, p. 110, pls. i.-iii.

² Barreswil, Compt. Rend. liii. 1861, p. 246. Voit, Zeitschr. wiss. Zool. xv. 1865.

of "guaninkalk,"¹ and the coloration elements of the skin have been investigated, in each case through a series of species of Teleosteans, by Ewald and Krukenberg², and by Cunningham and MacMunn³.

So far as I am aware, the histological and physiological changes involved in the sexual colour-differentiation of fishes have received but little attention. In fact, I believe that Heincke⁴, in his observations on *Gobius ruthensparri*, is the only contributor to this subject. In the goby some of the distinctions which Heincke supposed to be sexual have been shown by Guitel⁵ to be in some degree common to both male and female, and, although the male is certainly the more brilliant and especially at the breeding-season, the differences of coloration, except such as affect some of the fins, are only those of degree. The sexual colour-differentiation of *Callionymus* is infinitely more striking, and since my observations bring out some points not touched upon by Heincke, it appears worth while to put them forward even in their present imperfect condition. I hope to find time to complete them, and to include in my inquiry such other sexually dimorphic forms as may be procurable.

Pouchet's term "iridocyte," applied to plate-like aggregations of the reflecting substance which show some traces of a cellular nature or origin, has been retained by Cunningham and MacMunn, who apply a new term, "argenteum," to a layer of particles of similar substance which usually constitutes the most deeply-seated element of the colour-mechanism.

The authors show that the reflecting substance of the outer layer is not always found in the form of definite plate-like bodies, but may be present in minute particles of variable shape, which apparently do not always differ from the particles composing the argenteum except in their topographical relations. It was found that the reflecting substance usually consisted of guanin, though calcium phosphate was present in some species.

I cannot at present deal with the chemical nature of the colour-elements in the Dragonet, and must therefore confine myself to a preliminary discussion of their disposition and sexual and developmental differentiation.

Since the young male and the female are identical in coloration, it is only necessary to compare the several colour-phases of the former sex. The Dragonet is said to have no scales, and a minute histological examination of the skin shows no obvious trace of such structures. It is most abundantly supplied with mucus, which it throws off in slimy clouds when irritated. The secretion

¹ Kühne u. Sewall, Untersuch. Phys. Inst. Heidelb. iii. p. 221.

² Zeitschr. f. Biol. xix. 1883.

³ Phil. Trans. R. S. clxxxiv. 1894, p. 765. I am indebted to these authors for most of the above and for other references.

⁴ Schr. Naturw. Ver. Schlesw. Holst. 1875, i. p. 290. A full translation is given by Smitt, Hist. Scand. Fish. ed. 2, i. p. 242.

⁵ Arch. Zool. Expér. sér. 3, iii. 1896, p. 264.

is as abundant in young examples as in old. I have found neither chromatophores nor reflecting substance in the epidermis. The numerous large epidermal alveoli of the mucous system need not here concern us, since, though apparently acting to some extent as condensers, they do not alter the effect of the underlying coloration-elements and are alike in both sexes.

The second dorsal fin is one of the parts most conspicuously coloured in the mature male. In the young undifferentiated male the markings are sombre. If a young specimen be compared with the drawing (Plate XXVI.), it will be seen that the yellow area (of the adult) is brown, the blue lines are opaque white, and their grey margins are colourless and transparent. Sections of this fin show that the skin consists, internally to the epidermis, of loose connective-tissue cells overlying a thin fibrous layer, apparently representing the chorion. Except where the rays intervene, this layer is closely apposed to the corresponding element of the skin of the other side. The chromatophores lie in the loose connective tissue already mentioned.

In the young male the brown bands are found by microscopic examination to derive their colour from very numerous yellow and black chromatophores. In connection with the latter are frequently seen underlying masses of finely granular matter, of a brownish colour by transmitted light. As the chromatophores contract it becomes evident that there is a large quantity of apparently similar matter arranged in a continuous network resembling strands of dendritic chromatophores. By reflected light this network takes on a pale yellow colour. It has hardly any iridescence.

Passing towards the transparent areas which border the white bands, one observes scattered chromatophore-like aggregations of the same substance, some of which contain a little black pigment, while intermediate conditions lead up to perfect black chromatophores. It appears, therefore, that these bodies are merely degenerate black chromatophores. The transparent areas are simply devoid, or nearly so, of any sort of coloration-element. The white bands have a few black chromatophores, but the degenerate structures are much more numerous. The opaque white appearance is derived from a granular reflecting matter, arranged in an irregular network, appearing steel-grey in colour by reflected light over a black surface. So far as I can see, it has no connection with the chromatophores, though it may be of the same chemical nature as the granular matter associated with the latter.

In the adult breeding male the brown bands are brilliant yellow. This result appears to have been achieved (i.) by the reduction of black chromatophores, which are now much less numerous than in the undifferentiated stage and sometimes entirely absent, (ii.) by the excessive development of yellow pigment.

In the fresh condition the ground-colour of the yellow bands is a diffuse yellow; no separate yellow chromatophores can be discerned until the diffuse stain has been extracted by a reagent.

They are then seen to be stellate in character, but much smaller than the black ones. Cunningham and MacMunn, who record an approach to this condition of diffusion (*op. cit.* p. 776), provisionally suggest that the coloured pigment in the flounder and plaice diffuses from the connective-tissue cells in which it is deposited¹.

In the case of *Callionymus*, comparing the young and adult conditions, no other conclusion seems possible. A complete network of granular matter certainly represents the black chromatophores present in the younger stages.

The white bands and their transparent margins have become blue, with a border of grey, but only black chromatophores are present. The latter are abundant in the grey area, and are here of a dendritic nature. In the blue part I find them less numerous and, in microscopic preparations, much less expanded, the radii being very short and the centre very dense. In both cases they are frequently, if not always, associated with underlying masses of a granular matter. The brilliant blue colour is derived from a dense network of bundles of small, somewhat bean-shaped bodies. The latter are yellow by transmitted light, but intensely blue by reflected light over a black ground, such as is afforded by a black chromatophore. They occur immediately below the epidermis. It is difficult to isolate them, as in the process of teasing out they are readily ruptured and resolve themselves into minute rod-like crystals. They appear to correspond to the iridocytes of Pouchet and of Cunningham and MacMunn, but are very minute, and are certainly not associated with the chromatophores in the same manner as is described by the last-named authors in the case of the flounder. I have not been able to detect a circular aperture, and have entirely failed to obtain sections. It will be perhaps more convenient to term them, provisionally, "*prismatic bodies*" instead of iridocytes.

They may probably prove to be identical with some reflecting substance found in small quantities by Cunningham and MacMunn (*op. cit.* p. 773), in *Siphonostoma*, but not, apparently, in other forms examined by those observers. They appear to be represented in *Gobius*, a form closely allied to *Callionymus*, and are there termed by Heincke "chromatophores filled with small discs of a metallic lustre." These "chromatophores" were supposed to contain pigment, but Heincke, who examined them only in the living fish, acknowledges that the pigment may have been really external. I find that the blue colour of the dorsal fin in the male *G. minutus* is identical in mechanism with that of *Callionymus*.

We have seen that these bodies are yellow by transmitted light. The rod-like particles into which they may be broken up are also yellow, but, though highly iridescent by reflected light, their iridescence is usually yellow, sometimes green, and only rarely

¹ The yellow pigment of *Carassius* was usually met with by the same observers in diffuse condition.

blue. It is therefore evident that the prismatic body owes its property of cerulescence to the manner in which its component parts are arranged. Owing to the minute size of the whole body, I have not been able to ascertain its internal structure. The bundles of prismatic bodies (fig. 1 *a*, p. 289)¹ are arranged in a direction roughly parallel to the axis of the fin-ray, the individual bodies transversely. Typically they seem to be arranged in a single layer, but often they overlap one another. The whole network lies in a slightly higher plane than the chromatophores, or at least passes over them when they are encountered in the same vertical plane. Sections of the fin are possible only when the bodies have been entirely removed by the action of acids, and I cannot find any trace of their associations with the connective tissue. Presumably they occupy the interstices of the latter, as suggested, for the iridocytes, by Cunningham and MacMunn. Their component rod-like particles may be simply deposited in a regular relation in such interstices, or may be held together by some matrix. None of these bodies occur in the grey margin of the blue band, where the colour-elements differ only from the young condition in the much greater abundance of black chromatophores.

In a male examined shortly after the breeding-season the yellow of the body has faded to a golden brown, while that of the fins is paler than at the time when pairing was in full progress. Examination of the yellow bands shows that the diffuse pigment is reduced in quantity. In the blue part are noticed aggregations of brownish granular matter, superficial to the prismatic bodies, sometimes alone, often in relation to a black chromatophore. I believe that they are derived from the degeneration of the black chromatophores, as in the case of apparently similar matter in the yellow bands. A reduction of the black chromatophores of the blue band would of course result in a diminution of the blue colour, since the prismatic bodies are blue only when backed by black.

It will be noticed that in the drawing (Plate XXVI.) the bands of the first dorsal fin are white with grey margins. This is the usual condition, but occasionally they have a certain blue tinge, especially near the base of the fin. The white appearance is derived from a network of reflecting matter, very similar to that of the blue of the second dorsal, but the individual prismatic bodies are considerably smaller, and there are very few black chromatophores in this region. In several specimens I find that the latter are superficial to the reflecting tissue. In an example in which the bands of this fin are distinctly though not very brilliantly blue, I find the prismatic bodies as large and as numerous as in the second dorsal. Black chromatophores are somewhat less abundant than in the other fin, but have the same relation to the reflecting matter, which is fully cerulescent over a black surface. The deficiency of colour is thus

¹ Fig. 1 *a* is only a sketch. The minute size of the bodies renders the use of the camera lucida impossible in their individual delineation.

evidently due to the comparative scarcity of black pigment. I have never seen the red tinge shown in Smitt's figure (Hist. Scand. Fish. ed. 2, pl. xiv.), but it is a fact that prismatic bodies, when seen by transmitted light in dense masses, tend to exchange the ordinary pale yellow for a warmer tint. In the hinder part of the blue margin of the axillary ocellus is an intensely brilliant region. Here it will be found that some of the prismatic bodies have a crimson colour in perfectly fresh preparations. Individually they are violet by reflected light over a black surface. The action of glycerine rapidly reduces them to the usual pale yellow tint, and I cannot say by what cause the crimson colour is produced.

With regard to the coloration of the body, the differentiation is achieved in a manner parallel to that which obtains in the dorsal fins. We need therefore only discuss the colour-mechanism of the adult male. The skin of the body differs from that which constitutes the fin-membrane in that the chorion is thick and tough and is associated internally with a further layer of loose connective tissue. In *Callionymus*, as was noted in the case of other Teleosteans by Cunningham and MacMunn, this inner layer frequently adheres to the muscles when the skin is stripped off. The epidermis, especially in mercuric chloride or old alcohol preparations, can readily be isolated. It contains neither chromatophores nor reflective tissue in any part which I have examined. In the blue bands of the side externally to the chorion are found black chromatophores in variable number, but often abundant. In the same plane and to some extent superficial to these occurs a diffuse layer of prismatic bodies, similar to those of the second dorsal, but showing less tendency to a retiform arrangement, owing to the closer approximation of the bundles. The internal layer of connective tissue is very rich in strands of prismatic bodies, overlying and passing between numerous black chromatophores. In preparations I find many of the latter completely contracted. It has been noted that these bands are subject to momentary intensification of colour, and it may reasonably be supposed that such intensification is effected by expansion of the chromatophores in response to nerve stimuli, causing a greater surface of black pigment to be interrupted by the overlying prismatic bodies. On the pelvic fin (*cf.* Plate XXVI.) are certain streaks of blue, which, during the breeding-season, remain of a constant deep hue. Here it is found that prismatic bodies overlies layers of black chromatophores so closely set as to present a practically continuous surface, a condition which sufficiently explains the constant character of the colour¹.

¹ Heincke found that (as I can confirm) in *Gobius ruthensparri* the metallic lustre is brought about by the crowding together of the "chromatophores" containing the glittering substance. *Callionymus* is too large to be conveniently studied under the microscope in life. Although the bundles of prismatic bodies show a *post-mortem* tendency to contract, it appears to me that the background is more influential in colour-production than the arrangement of the bodies.

Underlying the chromatophores of the inner layer of the skin in the blue bands (and elsewhere) are nests or aggregations of reflecting tissue in minute particles. Such are everywhere present in similar association with the black chromatophores in both sexes. When the chromatophore is fully expanded its central part is transparent and practically colourless, and the underlying nests can be seen from the outer side. In such aspects they are not refractive, but, if the preparation be reversed, they are found to have in part optical properties similar to those of the prismatic bodies. Particles of a nest will be found to glitter with the same blue colour, but in parts of the skin where yellow pigment occurs the latter affects them very strongly, causing the refraction to be chiefly yellow, sometimes green (from the mixed influence of yellow and black pigment?). In a nest underlying a black chromatophore remote from yellow pigment the bulk of the reflecting matter, viewed from the inner surface, is steel-grey in colour, portions, as already noted, being blue.

Reflecting matter of a similar nature forms a more or less continuous "argenteum" under the coloured parts, the minute elements being often, if not always, rod-like in shape. The skin of a young male, in which no prismatic bodies have been developed, can be cut with the microtome without the necessity of entirely dissolving out the reflecting tissue. Here the black chromatophores of the innermost series are seen in section, sometimes imbedded in a thickened depression of a continuous argenteum, sometimes overlying masses of similar tissue detached from each other.

The skin of the white ventral surface of the abdomen in old or young has a dense white argenteum and no chromatophores. The argenteum may be resolved into minute rod-like particles, similar to those obtained by rupturing the prismatic bodies of other parts, and to those which form the much thinner argenteum of the sides. The white effect appears to be due to the manner of their arrangement, since, if traced out, the elements of all reflecting tissue whatsoever seem to possess the same optical properties¹.

The masses of reflecting tissue underlying the black chromatophores (equally present in both sexes and at all sizes) can certainly play no part in the colour-mechanism of the body, since they are only refractive from the internal aspect. In the transparent fin-membranes they may feebly contribute to the coloration. Cunningham and MacMunn, who have noted that the iridocytes of the Flounder are closely embraced on the outer side by the black chromatophores, offer no suggestion as to the function of the former. It is difficult to see that they have any influence at all, in such association, on the colour-effect.

The results obtained by the various observers who have investi-

¹ For the present I do not include as reflecting tissue the brown granular matter, which I have shown to be probably a derivative of degenerate black chromatophores.

gated the colour-elements of the Teleostean skin suggest that guanin is probably the most important component of the reflecting tissue in *Callionymus*. My friend Mr. G. Brebner has detected its presence, and tells me that calcium is abundantly present in all parts examined, including the loose inner layer containing the argenteum. This was also the case in the reptiles, &c., examined by Ewald and Krukenberg¹. I have not found in *Callionymus* any large crystals of calcium phosphate, such as occur in the skins of some fishes. Judging from its optical effect, I do not suppose that the reflecting substance differs in chemical composition in different parts of the skin or in individuals of different ages. Apart from the yellow pigment I provisionally suggest that the colour-change is caused (i.) by the excessive development in the adult male of a reflecting substance (probably guanin) common to both sexes and all stages, and by the definite disposition of its particles in composite structures—the prismatic bodies; (ii.) by the distribution of black chromatophores in relation to the said prismatic bodies.

Agassiz and Ewald and Krukenberg refer to a paper by Brücke (Sitz. Wien. Akad., math.-nat. Classe, Jahrg. 1851), which I have not been able to consult. It appears that the author has dealt with the mechanism of the well-known colour-changes in the Chameleon, and demonstrated the property of cerulescence under certain conditions of the reflecting elements, which Ewald and Krukenberg subsequently found to be composed of guanin. We have seen that in *Callionymus* the property of cerulescence is confined to the prismatic bodies (if we except the occasional manifestation of the same property by particles of the masses of reflecting tissue which underlie black chromatophores), and that these bodies are found in association with black pigment only. With a view of testing the effect of the yellow pigment, I have isolated pieces of the blue skin from one side of the dorsal fin and compared the colour-effect of the prismatic bodies (i.) when the skin is viewed alone, in its natural association with only black chromatophores, (ii.) when the same skin is stretched over a bit of the yellow part of the same fin. It is at once apparent that the underlying yellow pigment changes the effect of the bodies as seen by reflected light. Instead of sapphire-blue, the resulting colour is a rich metallic green in general effect: though many individual prismatic bodies show various other tints; some, which, it may be presumed, happen to interrupt the view of yellow pigment only, being a pure yellow. It is evident that if, under natural conditions, the prismatic bodies were associated with both black and yellow pigment, manipulation of the latter would achieve a very considerable range of coloration.

¹ Untersuch. Physiol. Inst. Heidelb. iv. 1882, Heft 3.

VI. *The Soluble Pigment and the Palatability.*

The yellow colouring-matter, already noticed as diffusely present in the yellow bands of the fully-differentiated and breeding male, is very readily soluble soon after death. Francis ('Nature,' xiii. 1875, p. 167) has recorded the existence of a bluish-green pigment in the Australian Wrasses *Odax* and *Labrichthys*, which is soluble (presumably after death) in (fresh) water and sea-water. It is nitrogenous and is destroyed by heat, chlorine, acetic acid, alkalies, ammonia, and alcohol; precipitated but not destroyed by sulphuric acid; bleached by light. The yellow pigments of various fishes studied by Cunningham and MacMunn appear to have been less soluble, and these authors note that Francis's observations have not been confirmed. A bluish-green colouring-matter is certainly freely extracted from many European Wrasses in weak formaldehyde, but I have never tested its solubility in water alone. In *Callionymus* the yellow pigment is not given off in perceptible quantity during life, but very soon after death it readily dissolves out in fresh water, sea-water, dilute formaldehyde, glycerine, or alcohol without change of colour. Ether extracts an ochre-coloured solution; mercuric chloride changes the yellow parts to brick-red and extracts a solution of similar colour. Chloroform extracts no colour. A strong aqueous solution is not affected by heat nor by alcohol, is intensified by the addition of ammonia, becomes colourless with acetic acid, and much more rapidly with hydrochloric acid. The colour bleaches very rapidly in light.

The female has no yellow markings and no diffuse pigment, but a similar yellow colouring-matter is extracted in small quantity by alcohol from the chromatophores. Water appears to immediately extract only the diffuse pigment, and therefore has no effect on the female or young male.

A strong aqueous solution of the yellow from males has an odour resembling that of an acrid cucumber. The same smell is perceptible in the fish as a whole, and, to some extent, in both sexes. The solution has a subacid taste, not particularly disagreeable, but causes a prolonged irritation of the salivary glands. The same results are experienced if one chews a bit of the second dorsal fin of the male. The mucus can be easily obtained by irritating the fish. It is tasteless and non-irritant, so that the offensive properties clearly belong to the colouring-matter¹. It has been shown that the yellow pigment is most abundantly present at the commencement of the breeding-season and subsequently fades to a great extent. The manner of its disappearance requires explanation. Considering the nature of pigments generally, it seems improbable that the yellow matter is re-absorbed by the blood-

¹ I have not fully investigated the epidermal glands. It is possible that some of these may secrete the irritant fluid. If so, it accompanies the diffusion of the yellow pigment; but as the structure of the epidermis seems constant and no irritant matter is discharged by young examples, it is much more probable that the diffused yellow pigment is actually the seat of the irritation.

vessels. Is it simply diffused off into the water, or does it bleach *in situ* and so cease to be conspicuous? The former supposition seems to be the more probable, though it is not possible to see any trace of it. At present I have no means of applying any test other than that of vision, from a want of knowledge of its chemical nature. The researches of Gowland Hopkins¹ in Butterflies suggested to me that uric acid or urea would very probably be found in the yellow pigment. With the assistance of my friend Mr. F. Bishop Harman, M.B., I made several tests, but the results were negative. However, the fact remains that the pigment, whatever its exact chemical nature, is, presumably, an excretory product and has certain properties of taste and smell. It is found only in the skin, and differs entirely in that respect from the biliary colouring-matter which I have occasionally found infecting all parts of a Teleostean.

In considering the function of the pigment, it is necessary to note that it is exhibited, by the erection of the dorsal fins, not only in courting the female and in frightening smaller members of its own sex, but also in the attempt, successful or otherwise, to intimidate predaceous fishes. Since the pigment is certainly most abundant at the breeding-season, it may be presumed that it is primarily sexual in function. In this connection it is not easy to decide whether it appeals only to the visual faculties of the female or to her sense of smell as well. The impression I have gathered from repeatedly watching the Dragonets in the aquarium tank and in a large table-tank in the main laboratory is that these fish, in which the olfactory organ is very small, depend almost entirely upon their eyesight in feeding. I have often seen them take into their mouths quite uneatable substances which bore a casual resemblance to the worms which form their usual food. To further test the matter I made a decoction of *Nereis diversicolor*, the worm in common use here, by pounding up a number of specimens in a little sea-water. The fluid poured off must have been, to the olfactory sense of a fish, identical with the actual worm; but the Dragonets in the table-tank took no notice of it whatever. A prawn evidently perceived it, and began to hunt about where some of the suspended particles had fallen. A portion of the same fluid dropped into one of the large aquarium tanks had the effect of rousing a shoal of grey mullet and some red mullet, previously quiescent, to great activity in search of food. It is evident, therefore, that *Callionymus* is not keen of scent, since a few worms dropped in their tank suffice to bring them from all parts to share the feast. I have not devised any means of testing the effect of smell on the sexual passions of the fish as apart from its appetite, but I can affirm that the yellow pigment is neither distasteful nor terrifying to young members of the species. I made an aqueous solution of the yellow from the dorsal fins of a mature male and soaked in it small balls of cotton-wool, which

¹ Proc. R. S. lvii. 1894, p. 5, &c.

were dropped into the large table-tank. Several wrasse, *Labrus* and *Crenilabrus*, darted at these objects, but either retreated without touching them or dropped them as soon as they were seized, and departed in evident disgust. Gobies, chiefly *G. paganellus*, investigated the matter and seized the coloured balls, but mostly dropped them very shortly. One carried off a ball to a shelter in the middle of the tank, but then dropped it. Only one goby made any attempt to masticate a ball, and that was soon abandoned. The young *Callionymi*, on the contrary, took the balls greedily and chewed them. The same fish would take a ball, chew it for some time, reject it and seize it once more. Certainly the yellow matter was not distasteful, nor was the colour terrifying. Fragments of the second dorsal were treated in the same way as the balls by wrasse and gobies, but greedily attacked by young *Callionymi*; the fin-membrane was swallowed, when separated by repeated chewing from the rays. A quantity of the solution was poured over the assembled *Callionymi*, who took no apparent notice of it. A wrasse saw the yellow colour and darted out of its hiding-place, but rapidly retreated on reaching the foreign matter. It seems, therefore, that terror is inspired in young Dragonets by the menacing gestures of the courting male, and not by the optical or olfactory properties of the yellow pigment. Of course I am not contending that the yellow colour is actually attractive to young Dragonets, since most of the fish, of whatever species, in the table-tank are so far tame that they will come and look at anything that is offered to them. It appears to me impossible to decide in what manner the elements of the coloration of the male influence the female. If it appeals to her sense of scent, the yellow element only can be concerned, since the blue results from a combination of two elements which are not soluble. It certainly appears most probable that the whole coloration-effect merely renders the large dorsal fins more conspicuous and so advertises the whereabouts of the male. As we have seen, the dull-coloured female does not appear to be readily perceived by the male even at the distance of a few yards. Her presence may presumably be indicated by some odoriferous product of the genital organs at the season of ripeness.

Apart from the sexual question, we have seen that the yellow colouring-matter is distasteful to gobies and wrasse. The latter, however, are not to my knowledge fish-eaters. Gobies are more or less indiscriminate in their appetite. Except dog-fish, rays, and conger, which seldom feed in the daytime, the only large fish-eating forms in the aquarium are pollack and turbot. Both these species must be present on the *Callionymus* ground during the breeding-season. The pollack feeds very largely on fish. Those in our tanks appear hardly large enough to take a full-grown Dragonet, so my experiments have been made with pieces cut from the sides of large males in various stages of colour, large females treated in the same way, and small living undifferentiated specimens. The larger pollack often took the bits of Dragonet,

but always rejected them. Bits of male and female, *with or without the skin*, appeared to be equally distasteful. A smaller pollack, present in the same tank, once took and retained a piece, probably because its opportunities of feeding are so limited by the competition of the larger fish that it cannot afford to be discriminating. These experiments were checked by offering bits of *Gobius paganellus* at the same time. The goby appeared much more palatable, most of the bits being taken and retained. A number of small living Dragonets were dropped into the same tank. Some reached the bottom in safety. Four were caught by the pollack, which swallowed two outright, one having had the preopercular spines removed. Another, with spines intact, was seized and held for so long that, even if not finally swallowed, it certainly could not have been violently distasteful to its captor. Another was seized by the tail and struck the pollack's lip or cheek with its spine and was instantly dropped. It was captured by another pollack and, I think, swallowed.

Some small Dragonets were offered to a number of pollack, about a year old and about 6 to 8 inches long. Most of them escaped into crevices of the rockwork or reached the bottom. One was seized and rejected, but perhaps swallowed by another fish in a dark corner of the tank. Another was seized and rejected, with evident manifestations of disgust, by five pollack in succession. The first four got it by the head and probably pricked their mouths, but the last seized it by the tail and seemed equally disgusted. Another, offered immediately afterwards, was smelt by most of the pollack, but taken by none. No dead individuals were taken, neither was a dead *Gobius minutus*, though this species is relished when living. The above evidence is rather conflicting. The larger pollack certainly appear to dislike bits of large Dragonets, but the seat of distastefulness is not entirely in the skin. The same pollack appear, on the whole, to approve of small Dragonets, while the latter seem to be distasteful to small pollack.

Pieces of large Dragonet were taken greedily and eaten by *Gadus luscus* and *G. minutus* and by *Cottus bubalis*. The last-named fish, however, will eat most things. Bass (*Morone labrax*) will not touch *Callionymus*. They are not fish-feeders. Wrasse (*Labrus maculatus* and *L. mixtus*) either decline to touch or at once reject bits of large *Callionymus*. As we have seen, young wrasse appear to dislike the pigment.

Turbot seem to find nothing objectionable in *Callionymus*. Small turbot and brill inhabit the bottom of the tank in which are the larger pollack. In the course of the experiments just described I noticed that the rejected morsels and such young Dragonet as reached the bottom were eagerly swallowed by the turbot (and, I think, brill also) as soon as they came within their sphere of influence. Some experiments with large turbot in the next tank have already been described. In addition I have on several occasions offered these turbot a number of dead male Dragonets

in full colour. The preopercular spines were removed from some, left intact in others, but the turbot swallowed all alike, the same fish taking several in rapid succession. The Dragonets being dead, the yellow pigment was in a highly soluble condition, and its properties of smell and taste must have been perceptible. Turbot hunt chiefly by eye, and those in the tanks will often take swimming crabs, but soon reject them. I have also seen them take "hard-heads" (*Agonus cataphractus*) and immediately spit them out again. In both cases I imagine that the armour of the intended prey was found to be compensated by no delicacy of taste. The Dragonets were often held in the mouth for some time until shifted into a position convenient for swallowing. I have never seen one even temporarily rejected.

As described above (p. 295), a living male Dragonet was taken by a turbot. Its subsequent proceedings appear worthy of record. The Dragonet, though successfully engulfed, appeared to be struggling and had almost certainly erected its preopercular tridents. The turbot seemed in great difficulties, making violent movements with its jaws and apparently unable to close its gill-apparatus, through which the dorsal filament of its victim occasionally protruded. Its efforts, however, appeared to be directed to swallowing, and were quite different to those which occur when the fish is trying to get rid of a swimming crab. After some time the turbot retired to a dim corner of the tank, and remained for several minutes quiet, but with gill-cover slightly distended. It then returned to the front of the tank, apparently all right. I tempted it with several dead *Callionymi*. It took no notice of the first five of these, which were taken by other turbot. As the sixth neared the bottom our friend made an advance towards it, but did not take it, and it lay on the bottom a little way off. The wave of a passing fish stirred it a little, and another slight advance was made, but without further result. Then commenced a series of violent convulsive twitchings of the abdomen, affecting the part lying behind a line from the anus to the extremity of the pectoral fin. They may have been caused by irritation from the spines of the victim, or may, more probably, be explained as an effort to pack it in a more convenient position. The twitchings lasted perhaps a minute or two. Then the fish circled round the end of the tank and returned to the same spot. A few more twitchings and matters seemed to be satisfactorily settled.

The turbot again made a circular tour, and, returning, appeared to perceive the dead *Callionymus*, now lying in a natural position, and swam at it as if about to take it, but stopped short and took the ground within an inch. Then commenced a rapid downward flipping of the fore part of the dorsal fin. The nostril underlies this region, and it was evident that the turbot was smelling at the *Callionymus*. The result was, apparently, not immediately inviting, but soon afterwards, having once more swum round the clear part of the tank, the turbot, in the act of settling, did finally

take the *Callionymus*—also some gravel. The latter was soon ejected, and the Dragonet swallowed without any difficulty.

According to my experience turbot, under natural conditions, feed entirely on fish, chiefly Clupeoids and sand-eels, and Cephalopods. In the tanks they are attracted by moving objects, and do not (except in the above instance) pause to smell their food. The experiments which I have described seem to show that the adult male *Callionymus* enjoys no immunity on account of the offensive properties, whether of taste or smell, of his person in so far as the turbot is concerned.

In the aquarium the yellow of the fins of some of the large male Dragonets had faded by the first week in April to a dull ochreous brown, the brilliant yellow of the body having disappeared long before. Nevertheless these fish still erected their fins on being menaced with a net quite as freely as during the season of brilliance, but required great provocation to induce intensification of the blue bands. This suggests that although the elements of the blue coloration are in great part retained after the breeding-season, the willingness to utilize them diminishes.

Under natural conditions the Dragonet is a frequent victim to the cod (M^r Intosh); I have myself recorded it from the stomachs of this fish and of the turbot and *Raia fullonica*. My colleague Mr. Garstang has found it (as noted by Poulton, *loc. cit.* p. 166) in the stomachs of red gurnards (*Trigla pini*). In this last case the victims were small individuals only. The long rough dab (*Pleuronectes platessoides*) also takes Dragonets (Ramsay Smith). During the breeding-season of this year I have often seen full-grown males among the refuse on the Plymouth quay from the stomachs of fish, chiefly anglers, and, I think, ling. In all probability the large tub-gurnards (*T. hirundo*) which abound on the breeding-grounds at this season, and are to some extent fish-feeders, may be also reckoned among the enemies of the Dragonet. I cannot speak from personal observation as to the feeding-habits of the red gurnard. The grey gurnard (*T. gurnardus*) makes great use of its sensory pectoral rays in searching for food¹, and protective coloration would not be an efficient defence against a fish of such a feeding-habit.

Tub-gurnard hunt both by sight and touch, but in experiments which I made I could get no evidence as to the palatability of *Callionymus*, since on that occasion our aquarium specimens would not even interest themselves in worms, usually a favourite food. Cod hunt by sight (Bateson, *loc. cit.* p. 241), but a blind cod, as I have had the opportunity of observing, can detect the presence of food dropped into the tank and find it on the bottom. Indeed this fish must be largely dependent on senses other than that of sight at the great depths (over 100 fathoms) in which it commonly occurs in northern latitudes². It is an indiscriminate

¹ Cf. Bateson (Journ. M. B. A., n. s., i. p. 248), whose remarks appear to deal with *T. pini* and another species.

² Cf. Holt and Calderwood, Sc. Trans. R. Dub. Soc. ser. 2, v. 1895, p. 429.

feeder, taking even such unpalatable organisms as *Alcyonium* and *Actiniae*¹, so that it is not surprising to find that the various protective devices of *Callionymus* are frequently inefficacious. Whether or not the dorsal filament of *Lophius* is attractive to *Callionymus* I cannot say, but the male Dragonet, when courting, rushes heedlessly against anything that may be in the way, even against fully-expanded anemones, *Adamsia rondeletii*. *Lophius* appears to snap at precisely the spot where anything touches the erect filament², and, as a matter of fact, the Dragonets among the stomach-refuse on the fish-quay are mostly large males. Judging from the very varied assortment of things that have been found in the stomachs of *Lophius*, it may be presumed that its sense of taste is not very discriminating. I have not found Dragonets in the stomachs of John Dories (*Zeus faber*), but have seen a small specimen of the former taken and instantly rejected by a young dory. This fish does not appear willing to take anything from the bottom, though it will sometimes do so.

It is possible that prawns (*Palæmon serratus*) find something distasteful in the skin of a large male Dragonet. On two occasions I have noticed that a dead specimen placed in the table-tank was unmolested, though the prawns in the same tank will seize small individuals even before they are dead. A large male, which died in the aquarium tank during the breeding-season, was not injured by the crabs (*Cancer* and *Carcinus*) and hermits (*Eupagurus bernhardus*) for some time. The viscera and part of the muscles of a mature female were eaten, while her skin remained practically untouched; but I have seen a fully-coloured male chased by a *Carcinus*.

If the yellow pigment of the male is really obnoxious to any predaceous fish, it is evident that the female must also profit thereby at the moment when she is most exposed to danger, viz. when preoccupied in the matrimonial ascent.

VII. General Considerations.

The observations which I have collected above are certainly not so complete as they might be, but I do not think that further investigations will reveal many new facts in such part of the bionomics of the Dragonet as are intimately connected with the interpretation of the sexual dimorphism. Further study of the palatability of this fish, from the point of taste of the predaceous forms which it runs the risk of encountering under natural conditions, is certainly desirable, and will be carried out whenever opportunity permits.

In the meanwhile we know that the Dragonet is a species in which the male assumes, at a period roughly corresponding to the inception of sexual maturity, a differentiation of structure which

¹ Thomas Edward, 'Naturalist,' 1855.

² Cf. Holt, Sci. Proc. R. D. S., n. s., vii. 1892, p. 456.

distinguishes him at the first glance from his mate; that this structural differentiation is accompanied by the development on certain parts of a very conspicuous coloration, wholly absent from the female; and that the yellow element of this coloration has a distinct association with the ripeness of the genital product, rapidly fading after the early part of the breeding-season. We have seen that the yellow colour is that of a highly soluble pigment, characterized by a peculiar taste and smell, and distinctly irritant. The same pigment is present, in much smaller quantity, in the female; and the flesh, as well as the skin, of large examples of either sex appears to be unpalatable to at least one predaceous fish, the pollack, while even fully-coloured males are greedily eaten by the turbot. Male, female, and young alike possess a powerful preopercular spine, and are further protected by a copious mucous secretion. The male displays his secondary characters alike, whether in courtship (including the intimidation of younger members of his own sex), in competition for food with his own species, or in the apparent endeavour to prevent the attack of a predaceous enemy, though it is only in courtship that the jaws and teeth are fully exposed. We have no evidence of serious combat among mature males¹.

It remains to endeavour to fix the right interpretation of these various phenomena of form and habit. The coloration of the male sufficiently conforms to Poulton's definition of the epigamic character², in that the most conspicuous parts, at all events, are concealed when the animal is at rest. In the light of the pairing habit, unique, so far as I know, among fishes propagating by pelagic eggs, and of the readiness with which the blue colour is intensified during courtship, it is hard to regard the secondary structure and colour-characters otherwise than as due to some form of sexual selection. It matters little whether the excessive production of yellow pigment at the breeding-season has been evolved by sexual selection or whether it be an adventitious excretory process connected with genital activity. The possibility of the female being degenerate suggests itself, but is hardly supported by any evidence in the ontogeny. Perhaps in *C. lyra* the female presents a greater contrast to the male than in some other species of the genus; but, even if there were degeneracy in this sex, it might be regarded as a degeneracy from a condition originally acquired in response to the sexually-selected charms of the male.

I think it must be conceded that the account which I have given of the behaviour of the female at the time of pairing does not strongly support the view of an *æsthetic* sexual selection. In the dim light of 20 to 30 fathoms minute excellencies of design and colour-harmony must be hard to detect. Our female

¹ Cf. the perfectly harmless battles of courting spiders (Peckham, Occas. Papers, Nat. Hist. Soc. Wiscons., i. 1889, quoted by Poulton, 'Colours of Animals,' p. 310).

² *Op. cit.* p. 311.

appeared to exercise no choice at all, but simply took the nearest individual which offered the outward appearance of an able and willing male. I should hesitate to believe that the enlarged dorsals and brilliant colours of the male are other than a conspicuous advertisement of his whereabouts. It is practically certain that even in the small space of an aquarium tank the male cannot see the female unless she is quite close to him, and it is difficult to see why the converse should not hold good, were both sexes equally inconspicuous. It is true that when the male has found the female he continues to display his braveries, but in the absence of any evidence of individual preference on her part the æsthetic effect is at least doubtful.

In a much less degree the males of the allied genus *Gobius* and of *Blennius* and *Clinus* are distinguished by structure and coloration from the females. The admirably careful observations of Guitel¹ on the reproductive habits of these fishes give no indication of a sexual selection on the part of the female.

Males of *Clinus* and *Gobius minutus* were observed to fight for the possession of the female. Here the battles were of a serious nature and were decided by force of arms, the females being left to the victors. In *G. ruthensparri* the rivalry of the competing males was not carried beyond the stage of menace, and the result does not appear. In the other goby and in all the blennies serious combats ensue if the possession of the nest is disputed. Gobies and blennies appear to be polygamists, and if the females are more numerous than the males, the selective proclivities of the former are likely to be even less marked than in *Callionymus*, where the males preponderate.

It was observed by Savile Kent² that a male of *Gobius niger*, on being disturbed, distended its gill-covers and branchiostegal membranes, "with the evident intention of passing itself off as one of those spiny-headed Cottidæ which are not to be handled with impunity." If the inference is correct, this observation is probably important as bearing on the behaviour of *Callionymus*, since we are led to suppose by the context that the male in question was guarding its ova. In the forms studied by Guitel the same demonstrations of form and colour were made by the males whether in courting or quarrelling for possession of a mate, or in guarding the nest. It is possible that *G. niger* does actually mimic *Cottus*. It is perhaps equally possible that the unarmed gobies may be descended from spiny-headed progenitors, and may have retained the habit of protruding the once armed parts in courtship and defence of the young, if not also for ordinary purposes of self-defence. In *Callionymus*, as we have seen, certain demonstrations on the approach of danger are to some extent common to all stages of growth and to both sexes. I cannot find any important evidence that these phenomena are primarily or finally mimetic of anything

¹ Arch. Zool. Expér. : *G. minutus*, sér. 2, x. 1892; *Clinus* and *Blennius*, sér. 3, i. 1893; *G. ruthensparri*, sér. 3, iii. 1895.

² *Op. cit.* p. 242.

in particular¹. The preopercular spines being reserved as a second line of defence, in case the animal be actually seized, it appears to me that the object is either to simply disconcert the enemy by a rapid change of form, or to convey an exaggerated impression of size and strength. It is on some such line that one may suppose that a finally mimetic condition (as instanced in the Puss-moth caterpillar²) has been finally evolved, but in *Callionymus* it appears to go no further in this direction. As it seems to me a primarily aposematic feature has been seized upon and intensely developed, by the aid of a coloration perhaps resulting from a primarily adventitious excretory process, by a sexual selection acting, as befits the environment, rather in the direction of conspicuousness than of æsthetic charm³. A term, "sematepigamic," must perhaps be coined to suit the present condition.

If Stolzmann is right in considering the dances of male birds, not as a peaceful strife, but as a distraction to protect the female against the too constant attentions of the male, the same interpretation can hardly be placed on the courting antics of the male Dragonet. For here the only difficulty which appears to be felt by the female is to get as much male society as she wants.

Unless the female is degenerate, which I do not think we are entitled to assume, the free use by the male of his special characters for aposematic purposes appears to be of secondary origin; or, perhaps more justly, the male simply continues the aposematic demonstrations of his youth with apparatus that, fortunately for himself, has been improved by a sematepigamic process of selection. Beddard⁴ has suggested that similar, but not sexually-differentiated structures, the enormous pectoral of *Dactylopterus* and the dorsal fin of *Thymallus*, may be effective in diverting the attack of an enemy to a non-vital part. This is possibly the case, since we have seen that one male Dragonet struck at the first dorsal of another. The tub-gurnard (*Trigla hirundo*) furls its large and beautiful pectorals when at rest; but they are instantly expanded if the fish is molested, and are kept expanded when the fish is driven about or is simply swimming round the tank undisturbed. The John Dory instantly erects the dorsal filaments when alarmed, and these are supported by very powerful spines. On the whole it appears most probable in the two cases last mentioned and in the Dragonet

¹ I have observed that Pike (*Esox lucius*), when quarrelling, menace each other by inflating the whole gill-apparatus. In its natural environment it must be long since the Pike was associated with any object of mimicry more formidable than itself.

² Cf. Poulton, *op. cit.* p. 271.

³ Though it is possible that the brilliant coloration was originally acquired in shallow water, where details could be more readily appreciated.

⁴ *Op. cit.* p. 191. Messrs. W. L. Calderwood and G. P. Bidder have told me that when a *Dactylopterus* was placed in a tank at Naples containing some small sharks, the latter bit pieces out of its pectorals, a liberty resented by violent grunting. Gurnards and dories also grunt under circumstances of discomfort, the sounds being of the nature which appears from experiment to be perceptible by fishes. They may possibly subserve a function which is in part protective.



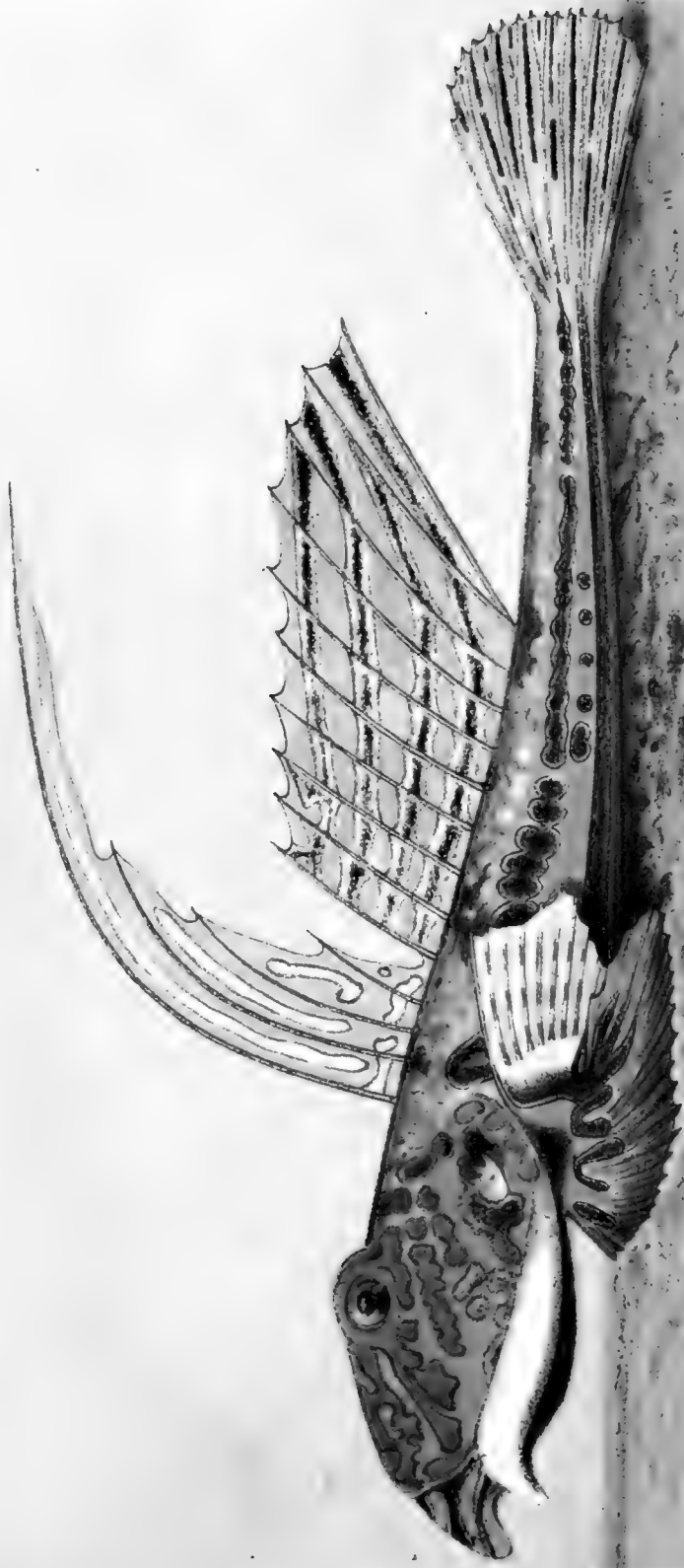

Anna J. Holt del.
Parter & Percy chromo-lith.

Callionymus lyra, ♂.

(The West & Sons imp.)

that the object is aposematic, the effect being achieved by a rapid transformation and apparent increase of size.

In conclusion, it is a pleasant duty to offer to my teacher, Professor Howes, my best thanks for the loan of literature and many references; and to my colleagues, Messrs. E. J. Allen and W. Garstang, for much assistance in various ways. I hope to be able, before long, to give a more complete account of the coloration-elements and mechanism and of the palatability of the species at different stages of the life-history.

EXPLANATION OF PLATE XXVI.

The Dragonet, *Callionymus lyra*. Male in full breeding-colour, in attitude of courtship. Drawn from a specimen living in the Marine Biological Association's Aquarium, February 1898. Reduced two-sevenths.

2. On the Serricorn Coleoptera of St. Vincent, Grenada, and the Grenadines (*Malacodermata*, *Ptinidæ*, *Bostrychidæ*), with Descriptions of new Species. By HENRY S. GORHAM, F.Z.S.

[Received March 3, 1898.]

(Plate XXVII. figs. 1-5 & 7-10.)

Although a considerable number of Coleoptera of the remaining families of the Serricorn series are here dealt with, it will be admitted that they represent but a very small portion of what may be expected when the larger islands of the West Indies have been more thoroughly examined for these groups. Among the wood-boring Beetles it is especially probable that further research will bring to light many endemic forms, and the list of species in the Lycidæ and Lampyridæ from Cuba renders it highly improbable that the Telephoridæ and Melyridæ are so poorly represented as the present collections would seem to indicate.

The fauna is in general quite similar to that of Central America. In the two islands from which the majority of the species collected by Mr. H. H. Smith come, there is a small admixture of more special South-American genera (*Astylus*, *Anidrytus*), but this is quite parallel to what obtains in Panama and in Costa Rica.

LYCIDÆ.

CALOPTERON.

Calopteron, Guérin, Voyage Coquille, p. 72; Gorch. Biol. C.-Am., Col. iii. pt. 2, p. 8.

CALOPTERON SMITHI, sp. n. (Plate XXVII. fig. 2.)

Nigrum, prothoracis lateribus elytrisque late aurantiacis, his macula magna dorsali communi marginem vix attingentem apiceque late nigris, antennis vix serratis. Long. 6-10 millim. ♂ ♀.

Hab. ST. VINCENT (*H. H. Smith*).

This is a small parallel species of *Calopteron* belonging to Section A. iii. in 'Biologia C.-Am.,' with four raised lines on each elytron, and the thorax with a simple carina. The antennæ are nearly simple in both sexes. The bases of the femora and the coxæ are often a little yellow, but only so at the joint.

The colouring of this insect is almost exactly that of *Emplectus lætus* Er., and is also very like that of *Calocladon ephippium* Gorh. It would also at first sight be apt to be confounded with the species which follows (*C. delicatum* Kirsch), but in addition to the form of the central black patch, there are minute differences in the sculpture. The costæ and cells are more distinctly raised in this insect; it is also wider behind, and hence less parallel. The females are, as usual, larger and wider than the males.

About twenty examples.

CALOPTERON DELICATUM.

Calopteron delicatum, Kirsch, Berl. Zeit. 1865, p. 61; Bourg. "Contr. à la faune ent. des États-Unis de Colombie," Ann. Soc. Ent. Fr. 1879, p. 37.

Hab. GRENADA: Balthazar, Mt. Maitland, Chantilly Estate (*H. H. Smith*).

Some examples of this little insect are very like *C. smithi*; the central black fascia, however, always reaches the margin; and the suture from the base to the fascia is black. The apical fifth is black; it is more parallel; the second and fourth costæ are distinct, but the first and third are very indistinct. The examples, nine in number, from Balthazar, all agree very closely, and are 7 to 10 millimetres long. One from Mount Maitland has the central patch detached from the base, and so far resembles *C. smithi*, but in other points agrees with *C. delicatum*, and, being from the same side of the Island of Grenada, I have no doubt pertains to this species.

CALOPTERON OBLITUM, sp. n.

Sublineare, niger, prothorace elytrisque sordide flavis, triente apicali et sutura usque ad costam secundam plus minusve nigris, costis secundo et quarto alte carinatis. Long. 8-10 millim. ♂ ♀.

Mas, antennis acute serratis.

Hab. GRENADA: Grand Étang, 1900 feet, St. Vincent, Kingstown, and windward side to 1500 feet (*H. H. Smith*).

This little species is of the size and form of *C. delicatum*, but it wants the central black fascia, and the thorax is entirely yellow. The pattern is one common to many Lycidæ. One-third of the apex of the elytra is black, and there is a more or less extended black smear down the suture, sometimes but rarely joined to the apical black. The scutellum is yellow, or at least with yellow scales. The antennæ are about as long as in *C. delicatum*, i. e. about as long as the elytra. The two raised costæ are very strongly elevated, while the intermediate ones and the areolets are very indistinct.

The following species from the West Indies, referred to *Calopteron*, are now placed in the genus *Thonalmus*:—

- C. amabile*, Jacq. Duv. Hist. Cuba, 1857, p. 82. Cuba.
C. auricum, Jacq. Duv. l. c. p. 77, t. 7. f. 18. Cuba.
C. bicolor, Linn. Amœn. Ac. vi. 1763, p. 395. Haiti, Jamaica, Cuba.
C. distinguendum, Jacq. Duv. l. c. p. 80. Cuba.
C. dominicanum, Chev. Ann. Soc. Ent. Fr. 1869. San Domingo.
C. suave, Jacq. Duv. l. c. p. 80. Cuba.

And the following are recorded from Cuba, but are unknown to me:—

- C. elegantulum*, Jacq. Duv. l. c. p. 78. Cuba.
C. albicollæ, Chev. Rev. Zool. 1858, p. 209. Cuba.
C. denominatum, Chev. Ann. Soc. Ent. Fr. 1869. Cuba.
C. nigritarse, Chev. l. c. 1869, *C. semiflavum*, Chev., and *C. pectinicornæ*, Chev. l. c. 1869.

PLATEROS PALLIATUS, sp. n.

Plateroti forrerano Gorb. *affinis et summa similitudine; niger, prothorace et elytris læte flavis, his macula magna subbasali, communi basin attingente (humeris et marginibus flavis), et quadrante apicali nigris. Long. 9–10 millim. ♀.*

Hab. ST. VINCENT (*H. H. Smith*).

Head, body with the legs, and antennæ entirely black. The thorax yellow, wider at the base than its length, the central channel deep, the disk irregular, with ridges running obliquely from the raised edges of the channel from the base and middle, the frontal carina not defined. The elytra have the shoulders rather widely yellow, and narrowly joined with a broad yellow posterior fascia, narrowed on its basal side towards the suture. The black subbasal patch is thus broadly cruciform, differing from that in *P. forreranus* (a Central-American species) in being joined to the base, and in being further extended down the suture. The scutellum is black. This insect very closely resembles *P. forreranus* Gorb. Biol. C.-Am., Col. vol. iii. part ii. p. 239, Suppl., but there are important differences which cannot be overlooked.

PLATEROS FRATERNUS, sp. n.

Niger, prothorace nitido, scutello et elytris flavis, his basi triente et quadrante apicali nigro-fumosis. Long. 7.5–8 millim.

Hab. ST. VINCENT (*H. H. Smith*).

The antennæ in this species are scarcely serrate; the thorax and scutellum yellow, and both shining, the former transversely square, with a rather prominent and elevated front margin. The channel and oblique ridges distinct but ill-defined. The elytra very evenly striated, and the punctures distinct. The basal black covers the whole base except the extreme reflexed margin, and its apical side is rounded, but not regularly, as the blackness extends

further along the interstices than on the costæ. Rather more than a third of the elytra in their middle is straw-yellow. The apical black is also rather irregular on its basal side. This insect mimics very closely the *Photinus* described hereafter as *P. notatus*, and is probably to be found in company with it.

Two examples.

ASPIDOSOMA.

Aspidosoma, Gemm. & Harold, Cat. Col. p. 1645; Gorh. Biol. C.-Am., Col. vol. iii. pt. 2, p. 58.

Aspisoma, Laporte de Castelnau, Ann. Soc. Ent. Fr. 1833, p. 145.

ASPIDOSOMA SUPERCILIOSUM, sp. n.

Oblongo-ovale, piceum, subnitidum, prothorace flavo interdum macula discoidali, ægre distincta, bisinuata, et duabus basalibus fuscis; elytris piceis, lateribus late, ad apicem angustiore et sutura tenuiter pallide flavis; scutello flavido. Long. 7-8 millim. ♂ ♀.

Hab. ST. VINCENT. GRENADA: Mount Gay Estate on the leeward side, and Caliveny Estate on the windward side, Woburn on the south end. GRENADINES, UNION ISLAND (1 ex.) (*H. H. Smith*).

The body and head are black, with the exception of the fifth and sixth segments in the male and the middle of these segments in the female, which are white, and that the tips of the trochanters and base of the femora and the basal joint of antennæ are pale. The thorax is ochraceous; in some examples the subdiaphanous part above the eyes appears as a dark spot taking the form of a bisinuate line, and in some there are two very obscure spots on the middle of the base. The scutellum is yellow, the præscutellar part fuscous. The form of the thorax is broadly semi-elliptical, slightly ogival in the males, and the sides and front are rather coarsely punctured. The elytra are pitchy black, with the entire sides and suture yellow, thickly punctured, and with two obsolete costæ. This insect is allied to, and of the same size and form as, *A. lepidum* (Biol. C.-Am. l. c. p. 54). It differs in the wholly yellow sides and suture of the elytra, and in the thorax being much less conspicuously marked.

The males scarcely differ from the females, except in the size of the eyes and more eburated luminous segments of the abdomen.

A large number of specimens were captured.

ASPIDOSOMA IGNITUM.

Aspidosoma ignitum, Linn. Syst. Nat. i. p. 645; Fabr. Syst. Ent. p. 201; De Geer, Ins. iv. p. 49, t. 17. fig. 2; Gorh. Rev. of Lamp., Trans. Ent. Soc. 1880, p. 83; Biol. C.-Am., Col. iii. pt. 2, p. 55.

Aspisoma polyzona, Chev. Col. Mex. Cent. i. fasc. iii.

Hab. ST. VINCENT: Kingstown. GRENADA: Mount Gay and Woodford Estates on the leeward side, Balthazar on the wind-

ward side. GRENADINES: Union Island (1 ex.), Mustique Island (H. H. Smith).

I have already in the 'Trans. Ent. Soc.' and in the 'Biologia C.-Am.' pointed out the above synonymy, and the series of specimens sent by Mr. H. H. Smith go far to confirm the correctness of that view. The great majority of the examples have pitchy-black elytra with pale sides as far as their middle, the margins thence to the apex with the suture narrowly yellow. The wide pale side contains two fuscous spots, one just outside the callus, the other below the middle. The thoracic markings vary a good deal in degree: in the St.-Vincent examples they are two squarish hook-shaped marks just separated by the central channel, and an obscure spot near the hind angles. In *A. polyzona* the inner side of the hook extends up the middle to the front margin, and is more or less fused along the channel, and in this form there are three pale lines on the disk of the elytra, *i. e.* the costæ are pale. Specimens of this kind occurred at Balthazar. Intermediate forms were found at the same place and at Mount Gay. Hence whatever difficulties there may be in identifying the *Lampyrus ignita* of Linnæus, I think there is no doubt that the present insect is not distinct from our Central-American species, and that it represents those South-American species which I have referred to it. *A. ignitum* has been previously recorded from the Antilles.

PHOTINUS.

Photinus, Laporte de Castelnau, Ann. Soc. Ent. Fr. ii. p. 141 (1833); Gorb. Rev. Lamp., Trans. Ent. Soc. 1880, p. 22; Biol. C.-Am., Col. iii. pt. 2, p. 38.

PHOTINUS NOTATUS, sp. n.? (Plate XXVII. fig. 3.)

Nigro-fuscus; pedibus (tarsis fuscis), prothorace (disco miniato) et elytrorum fascia lata postmediana flavis. Long. 8 millim.

Hab. ST. VINCENT: leeward side (H. H. Smith).

Antennæ rather long, entirely fuscous. Legs pale, the tibiæ (a little infuscate towards the apices) and tarsi fuscous. Prothorax entirely yellow, but that, as is often the case, when fresh the disc and underparts are pink or rosy, very even and smooth, only a faint indication of central channel. The elytra have a yellow band of rather more than a third of the elytral length, and produced a little both ways on the margins and towards the apex on the suture. There are three examples of this species, which is allied to *P. blandus* Mots. I have an example which is labelled "*notatus*" Gory, purporting to come from Brazil, but of uncertain origin; and as I do not know a species of the name attached, I give a brief description of our West-Indian insect.

PHOTINUS MINUTUS.

Pyropyga minuta, Leconte, Syn. Lampyr. 1881, p. 32.

If I am correct in referring the numerous examples obtained to

this species, it has a more extended range than I should have expected. It occurs in Florida and some of the Southern States, but not, so far as I am aware, in South America. *Ph. parvulus* Gorh., Mexico and Guatemala, and *P. decipiens* Harris, New York, Texas, Arizona, and Florida, are very nearly allied species.

Hab. ST. VINCENT: windward and leeward side, Kingstown. GRENADA: windward side, Grand Étang, Chantilly and La Force Estates; and leeward side, Mount Gay, Vendôme, and St. George's Estates (*H. H. Smith*).

Occurs from sea-level up to 2000 ft. altitude.

The following species of Lampyridæ have been previously recorded from the West Indies:—

- Lucidota dimidiatipennis*, Jacq. Duv. Hist. Ile de Cuba, p. 84.
L. janthinipennis, Jacq. Duv. l. c. p. 83. Cuba.
L. miniatocollis, Chevr. Rev. Zool. 1858, p. 209. Cuba.
Alecton discoidalis, Lap. de Cast. Hist. Nat. i. p. 266. Cuba.
Photinus blandus, Mots.; Jacq. Duv. l. c. p. 87. Cuba.
P. interruptus, Mots. (nec Erichs.), Etud. Ent. iii. p. 24, and
elongatus, Mots. l. c. p. 35. "Antilles."
P. limbipennis, Jacq. Duv. l. c. p. 86. Cuba.
P. littoralis, Mots. l. c. ii. 1853, p. 35. Martinique.
P. pallens, Fabr. Ent. Syst. Supp. p. 124; Brown, Nat. Hist. Jamaica, p. 431, t. 44. f. 9. Jamaica.
P. quadrimaculatus, Lap. de Cast. l. c. p. 269. San Domingo.
P. rufus, Oliv. Ent. ii. p. 28, t. 3. f. 30 (*Lucidota*).
P. vittatus, Fabr. (nec Oliv.), *vitiosus*, Gemm. Guadeloupe, San Domingo, Jamaica.
P. vittatus, Oliv. Ent. ii. p. 28, t. 3. f. 20. San Domingo.
P. vittiger, Gyll. Schön. Syn. Ins. iii. App. p. 21. Martinique, Guadeloupe.
Cratomorphus dorsalis, Gyll. l. c. p. 24. "Antilles," St. Barthélemy.
Photuris brunnipennis, Jacq. Duv. l. c. p. 89. Cuba.

TELEPHORIDÆ.

TYLOCERUS.

Tylocerus, Dalman, Anal. Ent. 1823, p. 57; Laporte de Castelnau, Hist. Nat. i. p. 276; Lacord. Gen. Col., Atl. t. 45. f. 1.

Anisotelus, Hope, in Royle's 'Himalaya.'

TYLOCERUS LINEATUS, sp. n. (Plate XXVII. fig. 1.)

Nigro-fuscus, subopacus; capite prothoraceque aurantiacis, hoc transverso, illo pone oculos superne nigro, linea basali mediana flava; coxis et trochanteribus pallide flavis; elytris nigro-fuscis, sutura margine laterali et apicali, et costa humerali ante apicem concolore albidis, scutello flavo. Long. 7-9 millim. ♂ ♀.

Mas, *antennis longioribus, articulo basali magno, inflato, segmento sexto ventrali fisso.*

Femina *plerumque minor, antennis brevioribus.*

Hab. ST. VINCENT: leeward side. GRENADA: Balthazar, Grand Étang and Mount Gay Estate (*H. H. Smith*).

Head orange-yellow, with the base behind the eyes fuscous, divided by a yellow but ill-defined line in the males; antennæ black, as long as the body in the male, about two-thirds as long in the female. Thorax transverse and rectangular, but the front angles broadly rounded, and the hind angles not prominent, orange-yellow, the margins reflexed. Scutellum, mesosternum, coxæ, and trochanters yellow, the posterior coxæ a little infuscate. Legs fuscous black. Elytra fuscous, not shining, the suture and margins narrowly pale, as is also a raised costa as far as the middle, which, however, is continued nearly to the apex; in some female examples it is almost concolorous throughout its length.

The males have the basal joint of the antennæ very large, nearly as long as the three succeeding joints, and swollen, the succeeding joints gradually increase in length, the apical joint is equal to those preceding it and is not enlarged. The palpi and tips of the mandibles are fuscous. In the female all the joints of the antennæ are shorter and thinner.

Dalman described one species of *Tylocerus* from Jamaica, *T. crassicornis*; and Lacordaire (*Genera Col. iv. p. 348*, note) identified specimens from the Isle of Barthélemy with that species. The figure in the 'General Atlas' is wrongly referred in Gemm. and Harold Cat. to this insect. It is that of *T. atricornis*, an Eastern species. The Eastern species have often the terminal joint of the antennæ enormously developed, and form Hope's genus *Anisotelus*. Mr. C. O. Waterhouse has proposed a genus *Sphærarthrum* for *Telephorus præustus* Guér., an insect from New Guinea, which appears to correspond with the New World *Tyloceri* in not having the apical joint of the antennæ of unusual form.

SILIS.

Silis, Latreille, Règne An. éd. 2, p. 471; Gorb. Biol. C.-Am., Col. iii. pt. 2, p. 91.

Ditemnus, Leconte, Class. Col. N. Am. p. 189.

SILIS TENELLA, sp. n.

Flava, capitis basi, antennis (articulo basali excepto), corpore (abdumine flavo-marginato) elytrisq; fuscis, his lateribus et apice late flavo-marginatis. Long. 4-5 millim. ♂.

Mas, prothoracis margine laterali plicato, pone medium interrupto, angulis posticis acute prominulis, ante excisionem in tuberculum acutum elevato.

Hab. ST. VINCENT: windward and leeward side (*H. H. Smith*).

The mouth, front of the head, the thorax, legs, and margins of the elytra are bright yellow. The antennæ are as long or a little longer than the elytra; their basal joint is yellow, the second and third are paler than the rest, as they are whitish beneath. The thorax is transverse, deeply sulcate, the sulcation not reaching the front

or the base. The legs are yellow, only the bilobed fourth joint and the claws and the claw-joint are infuscate. The elytra are coriaceous, the scutellum and the suture concolorous.

There is no species of *Silis* known to me with which this little insect can be readily compared; in size it is a little larger than *S. pauxilla* Gorh. (Biol. C.-Am., Col. iii. pt. 2, p. 304), but the sides of the thorax are quite different—the projecting tooth of the front part of the margin and the acute hind angle leaving a “nick” between them. The bright yellow legs and neatly margined elytra are different from anything I can recall in this now extensive genus.

Upwards of fifty species are described in the Biol. C.-Am. from Central America, several others are recorded from the United States, and there are numerous undescribed species in South America, besides many species from other parts of the world, which will fall into allied genera—as *Aclytia* from New Zealand; *Silidius* Gorh., Africa.

Eight examples were obtained.

C L E R I D Æ.

PELONIUM.

Pelonium, Spinola, Mon. i. p. 347; Gorh. Biol. C.-Am., Col. iii. pt. 2, p. 187¹.

PELONIUM INSULARE, sp. n.

Nigrum, elongatum, parallelum; antennis (clava excepta), prothorace (marginibus antico nigro), pedibus, scutello, sutura et elytrorum marginibus pallide ferrugineis; capite creberrime, prothorace parcius punctatis; elytris punctato-striatis, interstitiis levibus. Long. 5-6 millim.

Variat capite prothoraceque toto ferrugineis.

Hab. ST. VINCENT: leeward side, Mount Gay Estate (H. H. Smith).

In the section of *Pelonium* in which *P. quadrisignatum* Spin. and *P. crinitum* Klug come, this insect is most like *P. lineolatum* Gorh., from which it differs by the antennæ being yellow at the base, the legs wholly yellow, but is obviously variable in colour. When specimens have been collected from intervening localities, it is probable that several of the described species will be united as varieties; two specimens were obtained.

M E L Y B I D Æ.

ASTYLUS.

Astylus, Laporte de Castelnau, in Silberm. Rev. iv. p. 32; Gorh. Biol. C.-Am., Col. iii. pt. 2, p. 127.

¹ It is not deemed necessary to repeat the references and synonymy, which are fully given in the ‘Biologia.’

ASTYLUS ANTILLARUM, sp. n. (Plate XXVII. fig. 7, ♂.)

Astylo octopustulato Gorh. *similis et affinis at major, niger, capite prothoraceque subtiliter, elytris crebre rugose punctatis; his maculis tribus, marginibus cum macula magna subquadrata subapicali conjunctis, saturate aurantiacis, costa subhumerali nigra, et marginibus reflexis subexplanatis. Long. 10 millim. ♂ ♀.*

Mas, *elytrorum apicibus truncatis.*

Femina, *elytrorum apicibus profunde excisis.*

Hab. ST. VINCENT: leeward side (*H. H. Smith*).

Head subrostate, thickly and finely punctured, antennæ with the basal five joints rufous; thorax very even and smooth, a good deal narrowed in front, and with deflexed sides and front angles, finely, thickly, and confluent punctured. The elytra are more thickly punctured and less rugose at the base than towards the apex; the entire red margin and the apex in the female are somewhat expanded; each bears three irregular spots—one on the base pear-shaped with the pointed end towards the apex, nearly glabrous, but with a few scattered fine points, two others in a line and equidistant from the suture, not round as in *A. octopustulatus*, but rather oblique, and with faint indications of a costate interstice passing through them; the apical spot is much larger than in *A. octopustulatus*, squarish and united to the red margin. The submarginal costa is distinct, and terminates in the last black fascia. This beautiful insect is allied to, but amply distinct from, *A. octopustulatus* Gorh. l. c. p. 330, a species from Panama, where the genus apparently reaches its northern limit: it is larger, more deeply marked with orange-red, more coarsely punctured; the antennæ are longer, the spots are not nearly round as in that insect.

Only one pair were obtained.

EBÆUS.

Ebæus, Erichson, Entomographien, p. 113; Gorh. Biol. C.-Am., Col. iii. pt. 2, p. 120.

EBÆUS NIGROCÆRULEUS, sp. n.

Ebæo seminulo Er. *persimilis et statura æqualis, niger; elytris subcærulescentibus, subtilissime subcoriaceis, nitidis; antennis nigris, articulo basali subtus et secundo flavis; capite prothoraceque glabris, nitidis. Long. $\frac{3}{4}$ – $1\frac{1}{4}$ millim.*

Hab. ST. VINCENT: windward and leeward side and south end (*H. H. Smith*).

This minute Melyrid is so closely allied to the insects recorded in the 'Biologia C.-Am.' as *E. seminulum* and *E. minimum* Erichs., from Guatemala, that it is sufficient to refer to the differences, which are in the broader elytra, and the blacker legs and antennæ, and in the bluer tint of the elytra.

About a dozen examples were obtained, all in St. Vincent, where it is apparently common.

EBÆUS SEMINULUM?

Anthocomus seminulum, Erichs. Ent. p. 112.

Ebæus seminulum, Gorh. Biol. C.-Am., Col. iii. pt. 2, p. 121.

Hab. GRENADA: St. George's, Mount Gay, and Vendôme Estates, leeward side. GRENADINES: Becquia and Mustique Islands.

This insect is longer than *E. nigrocæruleus*, and quite black above. The legs seem darker than in the species I refer to this name from Guatemala, but otherwise the West-Indian insect is very similar.

EBÆUS MINIMUS?

Anthocomus minimus, Erichs. Ent. p. 113?

Ebæus minimus, Gorh. Biol. C.-Am., Col. iii. pt. 2, p. 121?

Hab. GRENADA: Mount Gay and Vendôme Estates, leeward side; Balthazar, windward side (*H. H. Smith*).

The very minute size (about $\cdot 75$ of a millimetre), black or blue-black colour, and the elytra widened behind (as in *E. nigrocæruleus*) distinguish this insect. It will be observed that the West-Indian insect has dark legs, whereas the Guatemala specimens had yellow legs. But there is not evidence enough to separate them.

PTINIDÆ.

PTINUS.

Ptinus, Linnæus, Syst. Nat. i. pt. 2, p. 565.

PTINUS TESELLATUS, sp. n. (Plate XXVII. fig. 8.)

♂. *Oblongus, brunneus, dense subrugose punctatus; antennis brevibus, articulis secundo ad decimum subæqualibus, obconicis vix elongatis, apicali parum elongato; prothorace hirtuli, postice transverse impresso parum constricto; elytris griseo hirtulis et pube flavo tessellatis, punctato-striatis. Long. 2.5 millim.*

Hab. GRENADINES: Mustique Island (*H. H. Smith*).

This *Ptinus* is not like any with which I am acquainted. The antennæ are short and with short joints more like those of *Niptus crenatus*: the thorax is constricted but not deeply, the widest part is in front of the constriction; the prosternal portion is very short, so that the head in repose must be reflexed; it is almost detached in the two specimens before me and could hardly be extended without being so. The eyes are prominent and rather coarse. The elytra have the sides parallel. The punctures are numerous in the striæ.

GIBBIUM.

Gibbium, Scopoli, Int. ad Hist. Nat. p. 505 (1777).

GIBBIUM SCOTIAS.

Gibbium scotias, Fabr. Spec. Ins. i. p. 74.

Hab. ST. VINCENT: leeward side (*H. H. Smith*).

One example.

MICRANOBIUM.

Micranobium, Gorham, Biol. C.-Am., Col. iii. pt. 2, p. 202.

MICRANOBIUM EXIGUUM.

Micranobium exiguum, Gorh. Biol. l. c. p. 202.

Hab. ST. VINCENT: leeward side. GRENADA: Balthazar, windward side (*H. H. Smith*).

There are only two specimens of the minute Anobiad which I think may be identical with the one I have described under this name from Guatemala; but if they do indeed represent the same species, I think they are the other sex. The three terminal joints of the antennæ are dark and much longer than the basal portion, the second abdominal segment is not much longer than the third, and the thorax is not laterally compressed; the head is received more into the thorax. These two specimens are rather larger and more shining than those here referred to *M. pulicarium*. In dry examples it is only possible by detaching the head and limbs to study them, as they are closely contracted.

MICRANOBIUM PULICARIUM.

Micranobium pulicarium, Gorh. Biol. l. c. p. 202, t. x. fig. 14.

Hab. GRENADA: Balthazar (windward side) and Grand Etang (leeward side); GRENADINES: Mustique Island (*H. H. Smith*).

This minute species is about 1 millimetre in length. It is distinguished from the *M. exiguum*? here recorded by its smaller size, by the whole insect being narrower and with a more compressed thorax, by the antennæ being much shorter, with the three terminal joints not much longer than the rest of the antennæ, and by the long second segment of the abdomen. The whole insect is brown, clothed with a grey, fine pubescence. I think the specimens may be females, but I do not think they are those of the preceding species, although one example is from the same locality, Balthazar. The antennæ are so short and delicate that the greatest care is necessary to extend them from dry specimens, clogged with gum.

CATHORAMA.

Catorama, Guérin, Rev. Zool. 1850, p. 431.

Cathorama (Gemm. Cat. Col.), Gorh. Biol. C.-Am., Col. iii. pt. 2, p. 207.

CATHORAMA HERBARIUM.

Cathorama herbarium, Gorh. Biol. C.-Am. l. c. p. 207.

Hab. ST. VINCENT: leeward side. GRENADA: St. George's and Mount Gay Estate, leeward side (*H. H. Smith*).

A series of examples of what appear to me to be identical with this species were met with.

This insect seems common and widely distributed; it is clearly

distinct from *Tricorynus zææ* Waterh., described from Barbados, although resembling it apparently in size and colour, as the elytra, in addition to the two submarginal striæ, have distinct rows of punctures. *Tricorynus* Waterh. is probably not distinct generically from *Cathorama* Guériu, and has priority; but as this is not absolutely certain, it will be as well to retain the latter name, being expressive of the deflected position of the head. Very little is known of their habits, but one has been found in tobacco-waste.

LASIODERMA.

Lasioderma, Stephens, Ill. Brit. Ent. v. p. 417; Gorh. Biol. C.-Am., Col. iii. pt. 2, p. 198.

LASIODERMA PUBERULUM, sp. n.

Breviter ovatum, castaneum, nitidum, fulvo-pubescent; antennæ perbreves. Long. 1 millim.

Hab. ST. VINCENT: leeward side. GRENADA: Lake Antoine and Telescope Estates, windward side. GRENADINES: Becquia Island (*H. H. Smith*).

Oval, the head very much deflexed as in *Cathorama*; the antennæ not longer than the breadth of the head, basal joint stout and large, the following joints to the seventh small, serrate, not longer than wide, the seventh to the eleventh as small and not serrate; eyes very finely faceted. The elytra are usually slightly deepened in tone as they approach the apex; they are not visibly punctured, and are, as well as the head and thorax, clothed with yellow, dense, but very close pubescence.

This is the smallest *Lasioderma* I have seen; it is very like a small *Cathorama*, but readily distinguished, apart from the generic distinctions, and when contracted, by its lacking the two submarginal striæ and by its greater pubescence.

The antennæ in *Lasioderma* are 11-jointed; the last four joints are in no way enlarged or lengthened (in *L. puberulum* they are about as long as broad). There is no sculpture visible under the $\frac{1}{4}$ -inch focus. A considerable number of examples occurred, chiefly at Telescope Estate. They are irregular in shape and broken.

The legs and underside are deep brown, pitchy in places.

LASIODERMA SERRICORNE.

Ptinus serricornis, Fabr. Ent. Syst. i. p. 241.

Pseudochina serricornis, Muls. Téréd. p. 175; Lec. Prodr. p. 238.

Lasioderma testaceum, Steph. Ill. Brit. Ent. v. p. 417.

Lasioderma serricorne, Gorh. Biol. C.-Am., Col. iii. pt. 2, p. 199.

Hab. GRENADA: St. George's, leeward side (*H. H. Smith*).

As I have remarked in the 'Biologia C.-Am.,' this insect is probably introduced through the agency of commerce. About fourteen examples were met with at St. George's by Mr. H. H. Smith.

MIROSTERNUS.

Mirosternus, Sharp, Trans. Ent. Soc. Lond. 1881, p. 526; Gorh. Biol. C.-Am., Col. iii. pt. 2, Suppl. p. 349.

Mirosternus is a genus of Dorcatomini, very nearly allied to *Cathorama*, but distinct in having eleven joints to the antennæ. The basal joint is large and pear-shaped; a little curved, the second shorter, but much stouter than those of the funiculus, which are six in number; the third joint is a little longer than the five following, which are very short. Of the three club-joints, which are similar to those of *Cathorama*, the two apical joints are each shorter than the ninth, which is hatchet-shaped, acuminate within.

MIROSTERNUS LÆVIS, sp. n. (Plate XXVII. figs. 5, 5 a.)

Oblongus, lateribus parallelis; nigro-piceus fere glaber, capite prothoraceque perminute, elytris minutissime punctatis, pedibus et antennis brunneis. Long. 3 millim.

Hab. ST. VINCENT: leeward side (*H. H. Smith*).

This insect is not unlike *Cathorama herbarium* at first sight, but it will on examination be found to be more parallel and narrower, and also smoother, without any trace of the submarginal striæ. The head and thorax, although more shining, are in *M. lævis* covered with small points, easily seen under a strong lens; the elytra are excessively minutely punctured, not in gemellate rows (as in *Cathorama*), indeed it is scarcely possible to say the points are arranged serially. The thorax is shorter than wide, its base is bisinuate, not margined in any way.

But one specimen has at present come under my notice; it is, however, in good condition.

All the *Mirosterni* yet described have been from one or two specimens of each. Dr. Sharp's species are from the Hawaiian Islands.

PRIOTOMA.

Priotoma, Gorham, Biol. C.-Am., Col. iii. pt. 2, Suppl. p. 350.

Priotoma is very close to *Dorcatoma*; it is separated by a very different structure of the prosternum. The species have from eight to ten joints to the antennæ, but these are very difficult of observation.

PRIOTOMA BREVIS?

Priotoma brevis, Gorh. Biol. C.-Am., Col. iii. pt. 2, Suppl. p. 351.

Hab. ST. VINCENT: leeward side (*H. H. Smith*).

Priotoma brevis was described upon two examples from Bugaba in the Isthmus of Panama, and the present insect is identical or very closely allied to it. The elytra are punctured with very fine rows, and are sparsely pubescent or pilose. The metasternum is sparingly punctured, the punctures being distinct.

Seven examples.

LYCTUS.

Lyctus, Fabr. Ent. Syst. i. p. 502 (1792); Gorh. Biol. C.-Am., Col. iii. pt. 2, p. 211.

LYCTUS PROSTOMOIDES.

Lyctus prostomoides, Gorh. Biol. C.-Am. l. c. p. 212.

Hab. ST. VINCENT: leeward side. GRENADA: St. John's River, leeward side (*H. H. Smith*).

A single example found at each of the localities does not seem to differ from examples of about the same size from San Lorenzo, Panama.

From the thorax being a little wider in front, and the sides accordingly contracting towards the base, I think these examples may be males.

SPHINDUS.

Sphindus, Chevrolat, in Silb. Rev. Ent. i. (1833).

SPHINDUS DUBIUS?

Sphindus dubius, Gyllenhal, Ins. Suec. i. p. 243; Jacq. Duv. Gen. Col. iii. t. 55. f. 275.

Hab. GRENADA: Balthazar (windward side) and Mount Gay Estate (leeward side) (*H. H. Smith*).

There is only one example from each of these localities, and I cannot see, on comparison of them with English examples of *S. dubius*, that they differ sufficiently to warrant their separation. Leconte was doubtful about the difference of his *S. americanus*, as he had not seen *S. dubius* (*cf.* Leconte, New Species of N. Am. Col. i. 1865, p. 104). Other American coleopterists seem to feel no doubt. Our West-Indian examples are rather small and rather short. *Sphindus* in England is usually found in a small black powdery fungus on the bark of beech trees.

BOSTRYCHIDÆ.

HETERARTHRON.

Heterarthron, Guérin, Icon. du Règn. Anim., Ins. p. 286; Lesne, Ann. Soc. Ent. Fr. 1896, pp. 111, 114.

Polycaon, Laporte de Castelnau, in Silberm. Rev. d'Ent. iv. p. 30; Gorh. Biol. C.-Am., Col. iii. pt. 2, p. 210.

HETERARTHRON FEMORALIS.

Apate femoralis, Fabr. Ent. Syst. i. 2, p. 361.

Heterarthron femoralis, Lesne, Ann. Soc. Ent. Fr. 1896, p. 118.

Polycaon exesus, Leconte, Proc. Ac. Phil. 1858, p. 74, ♀; Horn, Proc. Am. Phil. Soc. 1878, p. 553, ♀; Gorh. Biol. C.-Am. l. c. t. x. ff. 18 & 19.

Hab. ST. VINCENT: leeward side (*H. H. Smith*). ♀.

M. P. Lesne has adopted unhesitatingly the synonymy, which I pointed out as probable in the 'Biologia Centr.-Am.,' of *Polycaon*

exesus Leconte, as the female, with *Apate femoralis* and *Apate gonagra* Fabr. The former is the male, the latter the female, described from the Antilles. See the note on this insect in 'Biologia C.-Am.' I have specimens from Barthélemy (St. Bartholomew) Island.

XYLOPERTHA.

Xylopertha, Guérin-Méneville, Ann. Soc. Ent. Fr. 1845, Bull. p. 17; Gorch. Biol. C.-Am., Col. iii. pt. 2, p. 215.

XYLOPERTHA SEX-TUBERCULATA.

Sinoxylon sex-tuberculatum, Lec. Proc. Ac. Phil. 1858, p. 73; Horn, Proc. Am. Phil. Soc. 1878, p. 543.

Xylopertha sex-tuberculatum, Gorch. Biol. C.-Am., Col. iii. pt. 2, p. 216.

Hab. GRENADA: Mount Gay Estate on the leeward side (*H. H. Smith*).

There are three specimens of a *Xylopertha* which I refer to this. Two of them appear to be males. These have the muricate front portion of the prothorax produced more over the head than in others I have examined, and with a brush of golden hairs on that part, and also have the basal joint of the antennæ with a long cilia on the inner side, and the front of the head hollow and depressed between the eyes.

TETRAPRIOCERA.

Tetrapriocera, Horn, Proc. Am. Phil. Soc. 1878, p. 544; Gorch. Biol. C.-Am., Col. iii. pt. 2, p. 218.

TETRAPRIOCERA LONGICORNIS.

Bostrichus longicornis, Ol. Ent. iv. no. 77, p. 15, t. 3. f. 18.

Tetrapriocera swartzi, Horn, Proc. Am. Phil. Soc. 1878, p. 545.

Tetrapriocera longicornis, Gorch. Biol. C.-Am. l. c. t. x. f. 20.

Hab. GRENADA: Mount Gay Estate on the leeward side, and Balthazar on the windward side (*H. H. Smith*).

This insect has been recorded from Haiti and Guadeloupe, and has an extensive range from Florida in the United States, over the whole of Central America to Brazil. It is the only species known to me with a four-jointed club to the antennæ.

RHIZOPERTHA.

Rhizopertha, Steph. Brit. Ent. iii. p. 354 (1830).

Rhizopertha, Lacord. Gen. Col. iv. p. 541; Redt. Faun. Aust. ed. 2, p. 570; Jacq. Duv. Gen. Col. d'Eur. iii. pt. 2, p. 231.

Dinoderus, Gorch. Biol. C.-Am., Col. iii. pt. 2, p. 217 (pars).

RHIZOPERTHA BIFOVEATA. (Plate XXVII. fig. 9.)

Rhizopertha bifoveolata, Woll. Ann. & Mag. Nat. Hist. 1858, vol. ii. p. 409.

Dinoderus bifoveatus, Fleut. et Sallé, Ann. Soc. Ent. Fr. 1889, p. 419.

Dinoderus minutus, Fleut. et Sallé, l. c., nec Fabr. Ent. Syst. 1792, i. p. 363, nec Oliv. Ent. iv. no. 77, t. 2. f. 12 a-b.

Dinoderus substriatus, Gorb. Biol. C.-Am. l. c. p. 218.

Nec *Apate substriata*, Payk. Fn. Suec. ii. p. 142.

Nec *Dinoderus substriatus*, Jacq. Duv. l. c., nec auct. Europ.

Hab. ST. VINCENT: leeward side. GRENADA: Balthazar (windward side), Grand Étang Road and Mount Gay Estate (leeward side) (*H. H. Smith*).

Many examples.

The insect which I record here is not that generally known as *Dinoderus substriatus*, found in England and in various parts of Europe. Stephens, in describing his genus, assigns the insect he took for his type with doubt to Paykull's species. The Stephensian is, however, the same insect as that figured by Jacquelin Duval. Our West-Indian insect is a cosmopolitan species of *Rhizopertha*, easily known by its short thick-set form, by four or five concentric rows of muricate tubercles on the front of the thorax, but especially by the double fovea on its base. It does not agree either with the Fabrician description of *Apate minutus* nor with the figure given by Olivier, which latter, indeed, appears to me to represent the insect known to us as *Dinoderus substriatus* or an allied species, if, indeed, it ever really came from New Zealand at all. It will certainly save confusion in any case to adopt the Wollastonian name. *Rhizopertha* is distinguished from *Dinoderus* on account of the form of the last three joints of the antennæ. The tarsi are said by J. Duval to be "very short" in *Dinoderus*, "very long" in *Rhizopertha*: but the latter statement seems incorrect to me; I do not see much difference.

XYLOGRAPHUS.

Xylographus, Mellié, Rev. Zool. 1847, p. 109; Lacord. Gen. Col. iv. p. 549; Gorb. Biol. C.-Am., Col. iii. pt. 2, Suppl. p. 354.

XYLOGRAPHUS SUILLUS.

Xylographus suillus, Gorb. Biol. C.-Am., Col. iii. pt. 2, Suppl. p. 355, t. 13. ff. 21, 21 a.

Hab. ST. VINCENT: leeward side (*H. H. Smith*).

It is interesting to find this Guatemalan insect reoccurring in the West Indies. Specimens from St. Vincent are a little larger on the average than those from Central America, but are quite similar in other respects.

Seven examples.

CIS.

Cis, Latreille, Préc. Car. Gén. Ins. p. 90; Gorb. Biol. C.-Am., Col. iii. pt. 2, p. 220.

CIS PUSILLUS, sp. n.

Brunneus, thorace transverso, subopaco, lateribus tenuiter margi-

natis; elytris subtiliter punctato-striatis, striis ad latera profundioribus; antennis pedibusque testaceis. Long. vix 1 millim.

Mas, fronte.

Hab. GRENADINES: Mustique Island (*H. H. Smith*).

A little smaller than *Ennearthron affine*, and less convex, and also to be distinguished by the striate elytra, and the wider and more expanded sides of the thorax. The latter is extremely finely and very closely punctured, the punctuation under the microscope appearing broken and the interstices being aciculate. The armature of the head in the male is similar to that of *E. affine*, *i. e.* there arise two short acute prominences from the clypeus. I was inclined to believe this little species was an *Ennearthron*, but there are ten joints to the antennæ. The pubescence is a little more rigid and more disposed in lines on the elytra than in *E. affine*.

Five specimens.

CIS NUBILUS, sp. n.

Elongatus, depressus, fuscus, confertissime punctatus, pube brevi aureo-micante vestitus; elytris haud striatis; ore, antennis pedibusque testaceis. Long. 2 millim.

Hab. ST. VINCENT: south end (*H. H. Smith*).

The head in this species is transversely impressed between the eyes, the antennæ are entirely pale. The thorax is oblong, produced in front, very thickly and finely punctured, and the surface is alutaceous between the punctures, it is therefore not shining. The sides are very finely margined. The elytra are long and rather depressed, clothed with a pruinose but golden pubescence, finely but distinctly punctured; the punctures show a faint tendency to form lines, but are not serial. The legs are rusty red.

There are five examples of this *Cis*, which may be compared to the European *C. fuscatus*, Mellié.

CERACIS.

Ceracis, Mellié, Ann. Soc. Ent. Fr. 1848, p. 375; Gorch. Biol. C.-Am., Col. iii. pt. 2, p. 223.

CERACIS FURCIFER.

Ceracis furcifer, Mellié, Mon. p. 379, t. 4. f. 24; Gorch. Biol. C.-Am. iii. pt. 2, Suppl. p. 359.

Ceracis militaris, Gorch. loc. cit. p. 223 (pars), t. 10. f. 26.

Hab. ST. VINCENT: leeward and windward sides (*H. H. Smith*).

CERACIS MILITARIS.

Ceracis militaris, Mellié, Ann. Soc. Ent. Fr. 1848, p. 379; Gorch. Biol. C.-Am. iii. pt. 2, p. 223 (pars), and Suppl. p. 359.

Hab. ST. VINCENT (leeward side) (*H. H. Smith*).

The head in the male has the clypeus raised into a lamellate horn, and has two raised laminæ on the thorax in front. The

St. Vincent examples, both male and female, have the head and thorax blood-red.

CERACIS TRICORNIS.

Ceracis tricornis, Gorh. Biol. C.-Am., Col. iii. pt. 2, p. 224, t. 10. f. 27, ♂.

Hab. ST. VINCENT: windward side (*H. H. Smith*).

Of four examples taken together by Mr. Smith one is fortunately a male, exhibiting the prothoracic acuminate projections just as in the type from Mexico. The front of the head is raised into a laminar horn as in *C. furcifer*, but it is not bifurcate as in that species, but only emarginate at the tip.

CERACIS UNICORNIS, sp. n.

Nigro-piceus, nitidus, pedibus testaceis, thorace elytrorum latitudine, fere glabro, elytris levibus. Long. 1 millim.

Mas, capite cornu lamelliformi, thoracis longitudini æquali, apice integro, armato.

Femina, capite prothoraceque muticis.

Hab. ST. VINCENT (*H. H. Smith*).

The distinguishing character of this little species is the long, simple, lamelliform, and rather narrow horn which arises from the front of the head in the male, similar to that in *C. furcifer*, but longer and not bifurcate or emarginate at its tip. The head is somewhat excavated between the eyes in the male, in the female it is quite smooth and convex. The thorax is as broad as the elytra at the base; convex and rather bulky, the sides have an extremely fine reflexed margin. The mouth, antennæ, palpi, and legs are testaceous.

Four specimens, two males and two females, were obtained.

CERACIS BIFURCUS, sp. n. (Plate XXVII. figs. 10, 10 a.)

Piceus, nitidus, fere glaber, prothorace valido transverso, elytrorum latitudine. Long. 1 millim.

Mas, capite processu laminato, thoracis longitudine, utrinque ante oculos armato.

Hab. ST. VINCENT, ♂ (*H. H. Smith*).

Under the microscope the thorax in this curious little insect is minutely punctulate, and the elytra are obsoletely and minutely puncto-striate. The laminæ which arise from the head are broad and stout, inclined to each other, but projecting nearly straight, curving only a very little inwards; they arise from the inner side of the eyes, and are as long as the thorax; the apex of each is simply rounded.

EUTOMUS.

Eutomus, Dej. Cat. ed. iii. p. 331; Lacord. Gen. vii. p. 369.

Rhipidandrus, Lec. Class. Col. of N. Am. 1866, p. 236; Fleut. et Sallé, Col. de la Guadel., Ann. Soc. Ent. Fr. 1889, p. 420.

This peculiar genus has been placed by Lacordaire in the Scolytides, where it stands in Gemm. and Har. Cat. next to

Comptoscerus, by Leconte and Horn with the *Heteromera*, but more recently by those authors, and by Messrs. Fleutiaux and Sallé, with the *Cioidæ*.

The antennæ are 11-jointed, the fifth to the tenth joints dentate-lamellate internally, the apical joint compressed, nearly round. The palpi with awl-shaped apical joints. The tarsi are four-jointed, with a long claw-joint; the first three joints nodiform, not pilose or spongiose beneath. The pronotum robust, with distinct parapleuræ and sharp margins; its surface has the reticulate coriaceous sculpture of some *Cioidæ*. The elytra sulcate, with ridge-like acute interstices suggestive of an *Aphodius*.

The anterior coxæ are close together. The eyes are coarsely granulate and not cut out; the sculpture of the head is similar to that of the thorax, and is suggestive of *Hendecatomois*.

EUTOMUS MICROGRAPHUS. (Plate XXVII. fig. 4.)

Eutomus micrographus, Lacord. Gen. Col. vii. p. 370, nota; Fleut. et Sallé, l. c. p. 421.

Hab. ST. VINCENT: leeward side. GRENADA: Grand Étang (*H. H. Smith*). GUADELOUPE.

Lives in *Boleti* on trees according to the French authors.

EUTOMUS SULCATUS, sp. n.

Eutomus micrographo similis et affinis, sed minor, rufo-brunneus; capite prothoraceque creberrime subtiliter alutaceis; antennarum articulis quinto ad decimum longe dentato-laminatis, subpectinatis, apicali interne acuto; elytris sulcatis, sulcis perobsolete subrugosis. Long. vix 2 millim.

Hab. ST. VINCENT (*H. H. Smith*).

From *E. micrographus*, which this species very closely resembles in form, sculpture, and structure, *E. sulcatus* is distinguished by its much smaller size, its uniform brown colour, the longer lamellæ of the fifth to tenth joints of the antennæ, each lamella from the sixth joint being about as long as four joints of the funiculus, and their paler colour, by the acuminate apical angle of their terminal joint, and by the finer and less reticulate sculpture of the head and thorax.

About 20 examples of this species were obtained by Mr. Smith. It rather closely resembles a small *Aphodius* found by him in Grenada. The only other recorded species of *Eutomus* is a Madagascar insect, which very probably is not congeneric.

EXPLANATION OF PLATE XXVII. FIGS. 1-5 & 7-10.

- Fig. 1. *Tylocerus lineatus*, p. 320.
2. *Calopteron smithi*, p. 315.
3. *Photinus notatus*, p. 319.
4. *Eutomus micrographus*, Lacordaire, p. 333.
- 5, 5a. *Mirosternus lævis*, p. 327.
7. *Astylus antillarum*, ♂, p. 323.
8. *Ptinus tessellatus*, p. 324.
9. *Rhizopertha bifoveata*, Wollaston, p. 329.
- 10, 10a. *Ceracis bifurcus*, p. 332.

3. On the Coleoptera of the Families *Erotylidae*, *Endomychidae*, and *Coccinellidae*, collected by Mr. H. H. Smith in St. Vincent, Grenada, and the Grenadines, with Descriptions of New Species. By HENRY S. GORHAM, F.Z.S.

[Received March 3, 1898.]

(Plate XXVII. figs. 6 & 11, 12.)

The few species representing these families can hardly be regarded as typical of the West-Indian Fauna, but it will be observed that a considerable proportion are described as new. It is hardly possible, for instance, to believe that the Languriides are only represented by the abnormal genus *Hapalips*, which also occurs in Colombia. The principal interest of the present collection lies in the wide dispersion it suggests of some minute forms, with the general apparent absence, in the smaller island at least, of the more specialized genera, such as *Ægithus* and *Megischyrus*.

EROTYLIDÆ. (Subfam. LANGURIIDES.)

HAPALIPS.

Hapalips, Reitter, Verhand. des natur. Vereins in Brünn, 1877, xv. p. 122.

Corpus elongatum, depressum. Pedes haud longi; tarsi quadriarticulati, articulis tribus primis subtus membranaceis, hirtulis; antennæ 11-articulatae, articulis tribus ultimis clavam laxè articulatam præbentibus. Palpi maxillares articulo ultimo subuliformi. Oculi grosse granulati, magni. Mandibulæ apice bifidæ. Abdomen e segmentis quinque compositum, lineis coxalibus ægre distinguendis.

This name was proposed by Reitter for some species from Colombia which he placed between *Ips* and *Rhizophagus*. They are anomalous-looking Coleoptera. M. A. Grouvelle considers, however, that they are more nearly allied to *Languriides*, and I can see no reason why they should not be so placed. They differ however, from the known genera of that group in the following particulars:—They are depressed, reminding one of *Rhizophagus*; the elytra and some parts of the body are pubescent.

HAPALIPS GROUVELLEI, sp. n. (Plate XXVII. figs. 11, 11a, ♂, 12, ♀.)

Elongatus, depressus, ferrugineus, parcius pube brevi vestitus, punctatus; elytris punctato-striatis; prothorace subquadrato, margine antico prominulo, quasi lobato; antennis thoracis longitudine, articulo basali valido, secundo ad octavum gradatim brevioribus, intermediis subquadratis, tribus ultimis clavam laxam præbentibus, nono et decimo transversis, ultimo subquadrato. Long. 4-4.5 millim.

Hab. ST. VINCENT. GRENADA : Mount Gay, leeward side ; Grand Étang 1900 feet, Black Forest and Chantilly Estates, Balthazar, windward side (*H. H. Smith*).

The antennæ in this insect are placed well in front of the large, coarsely granulated, oval eyes ; the epistome is prominent, rounded in front, and its edge covers the antennal sockets (as in *Languria*) ; the crown of the head is somewhat elevated and nearly smooth. The front of the thorax projects like a hood over the base of the head ; with this exception it is quadrate, a very little narrowed behind, coarsely punctured, the middle of its disk rather flat, its sides and base margined. The prosternal process is distinct, with raised margins, and a little arched. The elytra have striæ, with numerous closely-packed, squarish, but rather obsolete punctures, becoming smaller and vanishing before the apex. The scutellum is transverse. The metasternum is very strongly and sparsely, the abdomen more thickly and less deeply punctate.

A considerable series of examples of this insect was obtained, principally at Mount Gay Estate.

HAPALIPS FILUM.

Hapalips filum, Reitter, Verh. des natur. Vereins in Br nn, 1877, xv. p. 125.

Hab. GRENADA : Mount Gay Estate (leeward side) ; Balthazar and Chantilly Estate (windward side).

ISCHYRUS.

Ischyrus, Lacord. Mon. Erotyl. p. 89 ; Crotch, Cist. Ent. i. p. 144 ; Gorb. Biol. C.-Am., Col. vii. p. 39.

ISCHYRUS GRAPHICUS.

Ischyrus graphicus, Lacord. Mon. Erotyl. p. 125 ; Gorb. Biol. loc. cit. p. 39, t. 2. f. 17.

Hab. ST. VINCENT (*H. H. Smith*).

In the specimens of this insect (eight in number) from St. Vincent, the two middle spots on the thorax are connected with a basal spot. The head is yellow, excepting at the base and round the eyes, and the apical black on the elytra is little developed ; otherwise it is very near *I. 4-punctatus* and *I. subcylindricus*. It has occurred in Mexico and in Nicaragua.

The following species of *Ischyrus* have been recorded from the West-India Islands :—

<i>Ischyrus fulvitaris</i> , Lacord. Mon. Erotyl. p. 129.	Haiti.
<i>I. flavitaris</i> , Lacord. l. c. p. 130.	Cuba.
<i>I. modestus</i> , Oliv. Lacord. l. c. p. 130.	Haiti.
<i>I. (Oocyanus) tarsalis</i> , Lacord. l. c. p. 106.	Haiti.
Also	
<i>Oocyanus violaceus</i> , Sturm, Lacord. l. c. p. 196.	Cuba.

ÆGITHUS.

Ægithus, Fabr. Syst. El. ii. p. 9; Gorh. Biol. C.-Am., Col. vii. p. 85.

ÆGITHUS CLAVICORNIS.

Chrysomela clavicornis, Linn. Syst. Nat. ed. x. p. 370.

Ægithus clavicornis, Gorh. Biol. l. c. p. 87.

Coccinella surinamensis, Linn. Cent. Ins. 10.

Hab. GRENADA: Mount Gay Estate and Mount Maitland, on the leeward side.

The localities recorded show this to be an abundant and widely-distributed species. Its occurrence, however, in the Antilles has not been recorded before.

Three examples.

EUXESTUS?

Euxestus, Wollaston, Ann. & Mag. Nat. Hist. 1858, vol. ii. p. 411.

The small insect here described presents, as does the type of Mr. Wollaston's genus (*E. parki* from Madeira), the greatest difficulty in its classification. M. Fauvel (Rev. d'Ent. x. p. 162) has regarded *Euxestus* as a synonym of *Plæosoma*, Woll. Both insects are now before me, and present great differences in the form of the body, in the length of the antennæ, in the proportion of their joints, in the length of the legs and structure of the tarsi. *Euxestus* is, however, also very similar to an Eastern genus of Motschulsky, *Tritomidea*. But they are not congeneric; the structure of the capitulus of the antennæ alone will separate them. Our insect from Grenada is so similar to *Euxestus parki* that I cannot at present point out any differences which would separate it generically, but it is probable they will be found.

EUXESTUS? PICICEPS, sp. n.

Elongato-ovalis, niger, nitidus, fere glaber; capite prothoracisque margine antico rufo-piceis; elytris subtilissime punctato-striatis; antennis, pedibus abdomineque rufis. Long. 1.75 millim.

Hab. GRENADA: St. John's River and Mount Gay Estate, leeward side; Balthazar and Grand Étang, windward side (*H. H. Smith*).

Shining, glabrous, nearly black above; the head, trophi, legs, and abdomen deep castaneous red. The antennæ are ten-jointed, if the capitular apical joint be considered as one, but there is probably a concealed joint in the summit of the capitulus, giving it the appearance of being slightly truncate at the tip, the suture (if one exists) not being made out under the microscope; the basal joint is large and globular, the second much smaller but stout, the third elongate, gradually widening from the base, the six funicular joints transverse, but becoming bead-shaped near the club. The maxillary palpus has its apical joint awl-shaped and rather long. The legs are stout and short, the femora wide and receiving the tibiæ into grooves. Punctuation is visible under the microscope, when the elytra are seen to have series of very fine

and numerous punctures continuing to near the apex, and interspersed with many irregular points, and the thorax is covered with very minute but distinct points. Underneath, the body is very shining and deep red, with the exception of the metasternum, which is black and which, with the abdomen, is glabrous.

About ten examples were found.

Obs. With regard to *Tritomidea*, if Motschulsky's drawing of the antenna be correct, there are but *five* joints to the funicular portion of the antenna preceding the capitulus, and that portion itself is made up of three joints, which is certainly not the case in the West-Indian insect.

ENDOMYCHIDÆ.

ANIDRYTUS.

Anidrytus, Gerstaecker, Monogr. Endom. p. 256; Gorb. Biol. C.-Am., Col. vii. p. 125.

ANIDRYTUS sp. inc. ♀.

Hab. GRENADA: Mount Gay Estate, leeward side (*H. H. Smith*).

A single female specimen of an *Anidrytus*, belonging to Section B, which are species of a depressed form and with the elytra not very ovate and but slightly convex. The *Anidryti* are very similar in form and colour, and it would be very difficult to determine this example in the absence of the male, but it appears to be most like *A. parallelus* Gerst. The genus has not, I believe, been recorded previously from the Antilles.

RHYMBUS.

Rhymbus, Gerstaecker, Monogr. Endom. p. 347; Gorb. Biol. C.-Am., Col. vii. p. 142.

RHYMBUS GLOBOSUS, sp. n.

*Orbicularis, valde convexus, niger; corpore subtus, pedibus inter-
mediis, et posticis elytrisque ferrugineis. Long. 1.75 millim.*

Hab. GRENADA: Chantilly Estate, windward side (*H. H. Smith*).

Very convex, shining, clothed with pubescence, which is greyish on the thorax and rufous on the elytra. Head, antennæ, palpi, and thorax black; the antennæ as long as would reach rather further than the hind angles of the thorax, 10-jointed. Thorax black and shining, the sides narrowly margined and reflexed; the basal sulci are distinct, wide at their bases, strongly convergent and arcuate, terminating as fine lines. Scutellum brownish. Elytra brown; the punctation is fine but just visible as separate points under the quarter-inch Coddington lens. The legs are red, with the tibiæ rather more obscurely pitchy or red, the anterior pair being more obscure than the middle and posterior legs.

Six specimens of this little *Rhymbus* were obtained; it is very distinct from any other described species.

RHYMBUS UNICOLOR, sp. n.

Orbicularis, valde convexus, ferrugineus, rufo-pubescentis; elytris crebre, minute, distincte punctatis; antennis fulvis, articulis duobus basalibus et apicali dilutioribus. Long. 1.75 millim.

Hab. ST. VINCENT, leeward side (*H. H. Smith*).

The size and form are precisely those of *R. globosus*, and the form of the thorax, the thoracic sulci, and the narrow reflexed margins are similar; the pubescence appears rather more ragged and rather less thick (perhaps owing to less fine condition), but the uniform colour very clearly distinguishes this little species, the only part which differs being the middle of the antennæ and the front portion of the thorax, which are darker rusty-red than the rest, and the apical joint of the antennæ, which is decidedly pale. This species is evidently nearly allied to *R. apicalis* Gerst., a Colombian insect, but is, I think, smaller, and better kept distinct as an insular form for the present. Nine specimens were obtained.

DIALEXIA.

Dialexia, Gorham, Biol. C.-Am., Col. vii. p. 146.

DIALEXIA PUNCTIPENNIS, sp. n.

Breviter oblongus, suborbicularis, parce pilosellus, castaneus, nitidus; elytris parce punctatis; antennis flavis, clava laxè triarticulata, nigra; prothoracis angulos posticos usque attingente. Long. 1 millim.

Hab. GRENADA: Balthazar, windward side (*H. H. Smith*).

The genus *Dialexia* was formed for the reception of a minute beetle (*D. setulosa* Gorh.) from Guatemala, of which, as in the present case, only a single specimen was obtained. They may be compared with the European *Aspidophori*. The antennæ are 9-jointed. In the present species there are faint indications of basal sulci, in two short lines at the base of the thorax (as in *Rhymbus*), and under the microscope ($\frac{1}{4}$ -inch objective) the elytra are distinctly but sparsely punctate. The determination of Micro-Coleoptera, when only single specimens are sent, must always at best be tentative. In the present case, however, the minute insect here described is in perfect condition, and on remounting it I was able to set out the legs and antennæ, so that I have no doubt of its position. The occurrence of a second species more than 1500 miles from the original discovery is an interesting fact, indicating the vast amount we have to learn about the distribution and classification of these minute forms of insect life.

The present insect is allied to *Rhymbus minutus* Gorh. and *Alexia minor* Crotch; and I would call attention again to my remarks on those species, in the 'Biologia,' under *Dialexia*.

I could not under any circumstances admit the *specific* identity of any of these upon evidence drawn from single examples from such distant localities. That must remain, I think, for some future student, when larger numbers have been collected.

COCCINELLIDÆ.

MEGILLA.

Megilla, Mulsant, Spec. Col. Trim. sécur. p. 24; Gorh. Biol. C.-Am., Col. vii. p. 151.

MEGILLA MACULATA.

Coccinella maculata, De Geer, Mém. Ins. v. p. 392; Gorh. Biol. C.-Am. l. c. p. 151, t. viii. figs. 19 & 20.

Hab. ST. VINCENT (*H. H. Smith*).

Very widely distributed in North and South America, and has been recorded from the Antilles by Olivier.

PSYLLOBORA.

Psyllobora (Chevr.), Mulsant, Spec. Col. Trim. sécur. p. 169; Gorh. Biol. C.-Am., Col. vii. p. 165.

PSYLLOBORA PUNCTELLA.

Psyllobora punctella, Mulsant, l. c. p. 173; Crotch, Rev. Cocc. p. 142.

Hab. GRENADA: Caliveny Estate, windward side, and Mount Gay Estate, on the leeward side (*H. H. Smith*). GRENADINES: Becquia and Mustique Islands (*H. H. Smith*).

Crotch remarks of this species, "easily to be recognized by the yellowish-white elytra, which have only two basal dots black." This may have been so in the specimens he examined from Trinidad and St. Vincent, but Mulsant expressly says that the elytra have four to five dots. And this is so: in the examples from Grenada there are always two basal and generally two median, and sometimes the three apical dots present; the latter may sometimes disappear altogether. The thorax has five dots forming an **M**.

[*Psyllobora nana* Muls. Spec. Col. Trim. sécur. p. 181: Cuba and Jamaica. *Psyllobora lineola* Fabr., Muls. l. c. p. 185: Martinique, Guadeloupe.]

CYCLONEDA.

Cycloneda, Crotch, Rev. Cocc. p. 162; Gorh. Biol. C.-Am., Col. vii. p. 169.

Daulis, Mulsant, Spec. Col. Trim. sécur. p. 296.

CYCLONEDA SANGUINEA.

Coccinella sanguinea, Linn. Amœn. Acad. vi. p. 393.

Daulis sanguinea, Mulsant, l. c. p. 326.

Cycloneda sanguinea, Crotch, l. c. p. 164; Gorh. Biol. C.-Am. l. c. p. 170.

Hab. ST. VINCENT, windward side. GRENADA: Mount Gay and Vendôme Estates, leeward side; Granville, Grand Étang, Balthazar, and Lake Antoine Estate, windward side. GRENADINES: Becquia and Union Islands (*H. H. Smith*).

This insect is distributed from the Southern States of North

America to Buenos Ayres, and has been recorded from Cuba by Mulsant and from Guadeloupe by MM. Flentiaux and Sallé.

CYCLONEDA DELAUNEYI.

Neda delauneyi, Flent. et Sallé, Ann. Soc. Ent. Fr. 1889, p. 483¹.

Hab. GRENADA: Mount Gay Estate, leeward side; Balthazar, windward side (*H. H. Smith*). GUADELOUPE¹.

The almost white marginal band of the elytra is sinuous just before the apex, and is almost divided there by the brown discoidal colour of their surface being prolonged into an acuminate point on the suture. The disk of the thorax is clouded, but the white sides are not defined by lines, as in *C. rubida*, and sometimes the whole thorax is whitish. Several allied species (as *N. viridula* Muls., to which the authors compare this insect; and *C. pallidula* = *C. rubida* var.) are light green when alive, which colour fades to a dirty yellow. The elytra in some of our examples are paler on the middle than towards the sides. Ten examples were sent by Mr. Smith.

HYPERASPIS.

Hyperaspis, Chevr., D'Orb. Dict. univ. d'Hist. nat. vi. p. 780; Muls. Spec. Col. Trim. sécur. p. 649; Gorh. Biol. C.-Am., Col. vii. p. 191.

HYPERASPIS FESTIVA.

Hyperaspis festiva, Muls. l. c. p. 659; Crotch, Rev. Cocc. p. 230; Gorh. Biol. C.-Am. l. c. p. 195.

Hab. GRENADA: Vendôme Estate, leeward side; Grand Étang, windward side (*H. H. Smith*).

The specimens, seven in number, which appear to be referable to this species, are of both sexes (the males with yellow, the females with black heads), but are somewhat discoloured, and seem rather more deeply punctured than typical examples. The difference is, however, very slight. The example from Grand Étang is a small male.

[HYPERASPIS CONNECTENS.]

Coccinella connectens, Schönh. Syn. Ins. ii. p. 157, nota.

Hyperaspis connectens, Muls. l. c. p. 662; Gorh. Biol. C.-Am. l. c.

Hab. WEST INDIES: St. Eustatius, St. Bartholomew.

Both these species occur also on the continent, and may be local varieties.

HYPERASPIS CINCTICOLLIS.

Cleothera cincticollis, Muls. Spec. Col. Trim. sécur. p. 553.

Hyperaspis cincticollis, Crotch, Rev. Cocc. p. 230; Gorh. Biol. C.-Am., Col. vii. p. 195, t. x. fig. 23.

Hab. GRENADA: St. George's and Vendôme Estates, leeward side; Granville, windward side (*H. H. Smith*).

This insect is hardly more than a variety of *H. festiva* in which

the yellow colour is more extended and the middle and apical fasciæ have become united. When found by Mr. Champion in the Pearl Islands, Panama, both forms occurred abundantly. Probably other slight differences might be found in examples from the mainland of Colombia, whence it was described by Mulsant. One example from each locality only.

CRYPTOGNATHA.

Cryptognatha, Muls. Spec. Col. Trim. sécur. p. 497; Gorb. Biol. C.-Am., Col. vii. p. 181.

CRYPTOGNATHA MELANURA, sp. n. (Plate XXVII. figs. 6, 6 a.)

Rufa; capite, prothoracis margine tenui antico et lateribus late albis; disco nigro; elytris sanguineis, pone medium nigris; pedibus pallidis. Long. 1¼ millim.

Hab. GRENADA: Mirabeau Estate, windward side (*H. H. Smith*).

This little species has the head, the extreme front edge and the sides of the thorax rather widely white, and the legs are nearly white. The disk of the thorax is black, and is, with the elytra, very finely punctured, the punctures scarcely visible except under the microscope. The elytra are chestnut-red, except in the apical third or rather more, which is black. The whole insect is (as usual in this genus) nearly orbicular and strongly convex.

There is only one example.

SCYMNUS.

Scymnus, Kugelann, in Schneider's Mag. i. p. 545 (1794); Mulsant, Spec. Col. Trim. sécur. p. 950; Gorb. Biol. C.-Am., Col. iii. pt. 2, p. 226.

Sect. I. DIOMUS.

SCYMNUS THORACICUS.

Coccinella thoracica, Fabr. Syst. El. i. p. 378.

Scymnus thoracicus, Muls. loc. cit.; Gorb. Biol. C.-Am. l. c. t. xxi. fig. 18.

Hab. ST. VINCENT, south end. GRENADA: Mount Gay Estate, Mount Maitland, St. George's and Vendôme Estates, leeward side; Balthazar, Lake Antoine, Mirabeau, La Force, and Caliveny Estates, Granville, on the windward side; Grande Anse, south end. GRENADINES: Mustique and Union Islands.

SCYMNUS OCHRODERUS.

Scymnus ochroderus, Muls. Spec. Col. Trim. sécur. p. 951; Crotch, Rev. Cocc. p. 270.

Hab. ST. VINCENT, leeward side, to 3000 feet. GRENADA: Mount Gay and Vendôme Estates, St. George's and Mt. Maitland, on the leeward side; Balthazar, Chantilly, Caliveny, and Mirabeau Estates, on the windward side. GRENADINES: Mustique Island.

The type of this species from St. Bartholomew is before me, and I see no difference between it and many examples sent by Mr. H.

H. Smith from Grenada. They are very like *S. thoracicus*; but are smaller on the average when a series like ours of about 35 examples is examined. They are, moreover, rather more oblong and more convex, and have a third of the elytra red at the apex, and this red part often more brightly coloured than in *S. thoracicus*. In some examples the thorax has a black spot on the base, as is more usual in *S. thoracicus*; but if we are right in our reference no reliance can be placed on the presence or absence of this mark, as the great majority of specimens of both species which I have seen are free from it.

SCYMNUS ROSEICOLLIS ?

Scymnus roseicollis, Muls. Opusc. Ent. iii. 1853, p. 270; Crotch, Rev. Cocc. p. 270; Flent. et Sallé, Ann. Soc. Ent. Fr. 1889, p. 484?

Hab. ST. VINCENT, windward side, sea-level; leeward side. GRENADA: St. George's, Mount Gay Estate, Vendôme Estate, Mt. Maitland, Grand Étang, leeward side; Balthazar, windward side; Grande Anse, south side (*H. H. Smith*). GRENADINES: Mustique.

There are about eighteen examples of a *Scymnus* among those sent from Grenada, which agree in many of their details with Mulsant's description, and as MM. Flentiaux and Sallé referred without hesitation a species from Guadeloupe to *S. roseicollis*, I do not venture to give our insect a new name. Our insect is oval, pointed towards the apex; the head, thorax, and two round spots detached from the apex are bright yellow; the body is blackish, only yellow towards the tip of the abdomen. The example in Crotch's collection is from Guadeloupe, but is not *S. roseicollis* Muls. in my opinion, and has no typical value.

SCYMNUS GRENADENSIS, sp. n.

Oblongus, convexus, dense griseo-pubescentibus, niger; prothoracis angulis anticis obscure rufescentibus; elytris singulis vitta angusta rufa, nec basim nec apicem attingente; pedibus flavis. Long. 1.25 millim.

Hab. GRENADA: Balthazar, windward side; Mount Gay Estate, leeward side.

This species is near to the one described by me as *Scymnus högei* (Biol. C.-Am., Col. vii. p. 230). It is smaller, more convex, and the red vitta of the elytra is of a different form, not being shaped like a comma, but of even width throughout. The head is obscurely red, the thorax is rather narrow and blackish, except near the front angles. The body is blackish; the punctation is not visible under a Coddington lens. The single example from Balthazar is the type; the specimen from Mount Gay is a little lighter in tone, the apex of the elytra and that of the body being distinctly red, but I think it obviously represents the same species. I cannot pretend to give further details, as the specimens



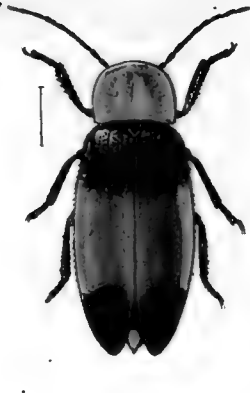
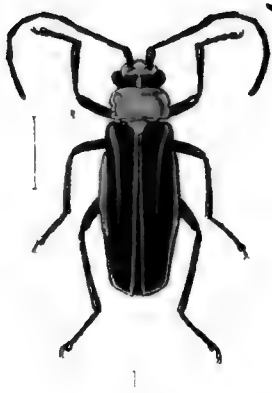

5a

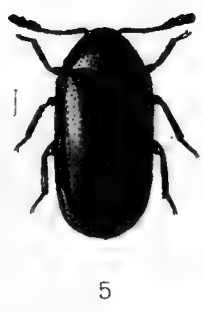

5



6

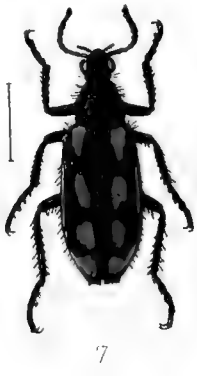

7



8



10a



11a



9



10



11



12

E. Wilson. Cambridge.

have been mounted with Canada balsam on card, and to clean them so as to really determine the form of the coxal fossettes would perhaps be only unsatisfactory. It is a distinct-looking species, and when found in the same or neighbouring islands ought to be recognized.

[SCYMNUS PHLÆUS.]

Scymnus phlæus, Muls. Spec. Col. Trim. sécur. p. 983; Crotch, Rev. Cocc. p. 271.

Hab. West Indies (*Chevolat*).

The type of this is not in Crotch's collection; a single example representing it is marked "*phlæus?*," and is from Caracas, but is valueless, being in miserable condition, and does not agree with Mulsant's description.

EXPLANATION OF PLATE XXVII. FIGS. 6, 11, & 12.

Figs. 6, 6 a. *Cryptognatha melanura*, p. 341.

11, 11 a. *Hapalips growvellei*, ♂, p. 334.

12. *Hapalips growvellei*, ♀.

4. Remarks on the Affinities of *Palæospondylus gunni*. In reply to Dr. R. H. Traquair. By Dr. BASHFORD DEAN¹.

[Received March 12, 1898.]

Whether *Palæospondylus* is to be accepted by zoologists as a Devonian hag-fish is a question of singular interest. For all views as to the kinships and descent of the Marsipobranchs, the outcome of widely-spread morphological and ontogenetic studies, must stand the test of this historic evidence. Thus, if *Palæospondylus* becomes the landmark in the descent of Marsipobranchs, this line must obviously have been both as ancient and as independent as those of other fish-like vertebrates.

But the evidence that *Palæospondylus* is a Cyclostome has yet to be satisfactorily furnished. Many of its accurately determined structures are distinctly unlike those of myxinoids or petromyzonts; while those features which appear at first sight cyclostomian occur also in other fish-like forms, and in the mouth, nasal region especially, may even in part be due to the imperfect preservation of the fossil. These objections, not unduly critical in view of the importance of the subject, become all the more formidable in view of the fact that paired fins may have been present.

The latter condition was suggested by the present writer, on the evidence of a specimen of *Palæospondylus* in the geological museum of Columbia University, presenting a series of transverse ray-shaped markings, which were interpreted as probably the basal supports of paired fins. The brief paper² in which the specimen

¹ Communicated by A. SMITH WOODWARD, F.Z.S. (See P. Z. S. 1897, p. 314.)

² Trans. New York Acad. Sci. vol. xv. 1896, pp. 101-104, pl. v.

was described tabulated also the reasons for and against the alliance of *Palæospondylus* with the Cyclostomes, maintaining finally that the sole character directly favourable to this alliance was the ring-shaped opening at the head terminal, and that even this evidence was far from convincing.

Some of these objections, however, were shortly answered by Dr. Traquair¹, the describer of the fossil and the vigorous supporter of its supposed cyclostomian affinities. The debatable specimen had been sent to him at Edinburgh; but it had not convinced him that the radial-shaped markings were other than petrological. He criticises, furthermore, several points in terminology, and, although he does not consider the balance of evidence as being against the marsipobranchian features, feels himself justified in concluding that the question of the affinities of *Palæospondylus* is left where it was after he had written his last paper on the subject: that is that, according to his interpretation of the fossil, there seems no escape from the conclusion that it must be classed as a marsipobranch.

The purpose of the present paper is to reply to the criticism of Dr. Traquair and to emphasize the *non sequitur* of his general conclusions. The latter purpose is the more interesting, for to retain *Palæospondylus* even provisionally in the position of a Devonian cyclostome will certainly, on such slender evidence, prove of little value, if not of actual harm, to phylogenetic studies.

The answer to the criticism of Dr. Traquair may be arranged:—

(I.) As to the “petrological” nature of the supposed fin-supports, and (II.) as to the matters of terminology.

(I.) The evidence that the markings first described by me are not petrological has in part been furnished me most generously by Dr. Traquair himself; for during a recent visit to Edinburgh he permitted me to examine the material of *Palæospondylus* both in the Museum of Science and Art and in his private cabinet; and a specimen of the latter he has even loaned to me for further study—kindnesses which I acknowledge gratefully. Among these specimens were two or three which showed distinct traces of the questionable markings as first described, in the same position, of the same general shape and size. That these markings re-occur so similarly seems to me conclusive evidence that they must be interpreted as *structures* of the fossil. But it will be objected that these markings have retained no organic matter, “mere shadows,” as Traquair expresses it, due to favourable illumination. Be this granted in every case but the first, where I am not satisfied that all traces of tissue have been weathered out: yet this objection is by no means fatal. For in numerous specimens of *Palæospondylus* the markings of the tips of the caudal fin-rays are equally lacking in organic matter, “mere shadows,” best to be seen with an oblique light,—yet no one will doubt that these ray-shaped shadows represent structures of the fossil. The writer has in mind entire specimens of *Palæospondylus* in Mr. Kinnear’s collection which have been intentionally “weathered out,” in which nothing remains but the “shadows” of head, vertebræ, and tail!

¹ Proc. Zool. Soc. 1897, pp. 314-317.

Finally, that the regular grain of the stone has produced the questionable markings, as Dr. Traquair maintains, has been pronounced untenable by those petrologists to whom I have shown specimens. The parallel striature he refers to, so common in many matrices, is finer, smoother, more regular, continuous, much fainter, not to be confused with the blunt-ended markings noted in the foregoing specimens. In view of the evidence of additional fossils one must, I believe, regard the markings as representing structures—whatever be accepted as their ultimate homology. Dr. Traquair denied before the British Association (1896) that my fossil had any value, prior to his examination of it, on the ground that in his many specimens there were no traces of the markings. This objection is now obviously invalid, since in his own collection have been found traces of them. Indeed there is reason why among several hundred fossils there might not appear prominent remains of structures as frail as the questionable fin-supports; for the specimens of *Palæospondylus* are, as a rule, poorly preserved. So far as I know, in all the materials extant there are very few specimens—a dozen or thereabouts—which deserve to be pronounced really good.

(II.) Dr. Traquair's criticism of my terminology is included under the following heads:—(a) the use of the term "oral" for what he believes to be "nasal"; (b) reference to the "diphycercal (or perhaps heterocercal)" caudal fin; and (c) supposed confusion of terms "radial" and "basal" fin-supports.

(a) The first of these is the important one. That the anterior "median cirrated opening" of *Palæospondylus* was described by Dr. Traquair as entirely nasal, altogether unconnected with the mouth, I have certainly been loth to believe. He refers to part of it in his second paper¹ as "the upper margin of a suctorial mouth," and later as "presumably nasal,"² and I have referred to it, partly on this account, as equivalent to the mouth-region of a myxinoïd³. He nowhere states that it is independent from the mouth, and, although his comparison is with Marsipobranchs in general, he repeatedly refers to *Myxine*⁴, in which the barbel-bearing ring of fibro-cartilage encircles the openings of both mouth and nose. That the "cirrated" ring should be regarded as nasal *only* seemed most unintelligible, for it was not probable that Dr. Traquair would wish to ally *Palæospondylus* to the Marsipobranchs by a character

¹ Proc. Roy. Phys. Soc. Edinb. 1892-93, xii. p. 90.

² *L. c.* p. 318, and Ann. Scot. Nat. Hist. 1894, April, p. 98.

³ He twice refers to the greater length of the lateral "barbels" and their origin "inside the margin of the ring, instead of from its rim like the others" (*L. c.* p. 96), a condition which further suggests to the reader the division of the opening into ventral (mouth) and dorsal (nasal) halves.

⁴ *E. g.* (Proc. Roy. Phys. Soc. Edinb. xii. p. 319) "... in the recent Marsipobranchs, two kinds of cartilage enter into the formation of the cranio-facial apparatus, of which one is considerably harder and more solid than the other. In *Myxine* the hard cartilage prevails in the cranium, while the soft variety enters largely into the structure of the hyo-lingual parts. A similar condition may have existed in *Palæospondylus*...."

absolutely unknown in the entire craniote phylum,—a terminal monorhinal ring bearing barbel-like structures. This would entail the development of a new theory of the vertebrate head, the *cirrhorrhinal*, as opposed to the *cirrhostomial* theory of Pollard. That this departure from our old-fashioned ideas of marsipobranch morphology

Characters of *Palæospondylus* with reference to Marsipobranchs.

<i>Evidence</i>	<i>Favourable</i>	<i>Unfavourable</i>
Oral cirri ...	Suggest somewhat the barbels of the nasomouth region of myxinoïd	Resemble even as much in arrangement and greater number the buccal cirri of <i>Amphioxus</i> . Dr. Traquair's evidence of cirrorhiny (protochordate?). On the other hand, similar mouth-surrounding tentacles evolved independently in many groups of fishes—siluroids, sharks, forms like <i>Pogonias</i> , <i>Hemitripterus</i> . A possibility, further, that the "cirri" may turn out to be remnants of cranial or facial structures of an entirely different nature.
Jaw parts ...	Unknown	Unknown. Possibility that the ventral rim of the "nasal ring" may prove to be the remains of Meekelian cartilage. (<i>Vide</i> Ann. Scot. Nat. Hist. 1894, pl. iii. figs. 1, 2).
Cranium	Utterly non-marsipobranchian. Massive cranium, over twice as large proportionately as in the lamprey. Huge auditory (?) capsules.
Vertebral column.	Utterly non-marsipobranchian. Highly evolved. Massive centra, prominent neural arches.
Paired fins...	Fatal evidence against marsipobranch affinities, if the ray-shaped markings are admitted to be the basalialia of paired fins. Their presence is alone sufficient, <i>ceteris paribus</i> , to cause <i>Palæospondylus</i> to be removed from its provisional position among the Cyclostomes. Also the "post-occipital plates" possibly represent a pectoral arch.
Caudal fin ...	Essentially marsipobranchian, especially its dichotomous rays.	Its condition also common, as diphycercy (and gephyrocercy), in other groups of fishes—sharks, lung-fishes, teleostomes.

was, however, actually intended becomes evident from his remarks on my earlier paper. And I sincerely apologize for having misunderstood his meaning. For now it appears that he interprets the ring and its cirri as "*cranial*" structures, and they must therefore be entirely unlike the myxinoïd ring, which is clearly

facial. Thus he himself rejects the most significant point of comparison of *Palæospondylus* with cylostome.

(b) To the second criticism, that in regard to the possible heterocercy of *Palæospondylus*, there is needed but a brief explanation. For in the first place Dr. Traquair, so far as I am aware, does not use either term, diphycercy or heterocercy. His figures, however, indicate clearly the diphycercal condition. I now remember, however, that I qualified it in parentheses as “perhaps heterocercal,” owing to the following sentence in Dr. Traquair’s third paper¹:—“A specimen which I obtained last autumn . . . shows that these rods or spines (of the tail-fin) were considerably longer than they had been represented in any of my figures, and consequently that the fin was so much deeper”²:—does this mean heterocercal?

(c) That Dr. Traquair has mistaken my use of the terms *radial* and *basal* fin-supports is possibly due to a hasty reading of my paper. The questionable markings had been described as lying within the line of the body-wall, therefore obviously interpretable as basals. They are, however, of the narrow rod-shaped form characteristic of radial fin-supports, and have, therefore, been termed from their shape “radial-like.”

To return next to the question of the affinities of *Palæospondylus*. The structural evidence it presents in likeness and unlikeness to the Marsipobranchs has already been tabulated, and may be repeated with additions (see p. 346).

From this comparison I am led to believe that *Palæospondylus* should not be given a place—even a provisional one—among the Marsipobranchs, leaving out of question the possibility of its having paired fins³. The weight of evidence certainly falls on the unfavourable side. But what position can be assigned to so problematical a vertebrate? Dr. Traquair agrees that “if *Palæospondylus* be not a Marsipobranch, it is quite impossible to refer it to any other existing group of Vertebrata.” Until at least a more definite knowledge of its structures shall warrant the change, systematists may be willing to accept it as the representative of the new subclass (or class?) *Cyclia*, constituted for it by Professor Gill⁴.

Columbia University,
Feb. 7, 1898.

¹ Proc. Roy. Phys. Soc. Edinb. xii. p. 316.

² The italics and parentheses are mine.

³ If the markings be the basalial of paired fins, the latter would certainly be of a ptychopterygial form. The markings cannot well be neural and hæmal spines, for reasons already given; nor ribs, from their size or shape; nor casts of muscle-plates, first from their shape, and second from their position, for in the neighbourhood of the gills muscle-plates, as experience has shown, are least likely to be preserved.

⁴ ‘Science,’ July 3, 1896.

May 3, 1898.

Prof. G. B. HOWES, F.R.S., F.Z.S., in the Chair.

The Secretary read the following report on the additions to the Society's Menagerie during the month of April 1898:—

The total number of registered additions to the Society's Menagerie during the month of April was 165, of which 101 were by presentation, 43 by purchase, 3 were received on deposit, 17 were born in the Menagerie, and 1 was received in exchange. The total number of departures during the same period, by death and removals, was 87.

Among the additions attention may be specially called to two birds forwarded by Dr. Goeldi, C.M.Z.S., from Pará, and presented to the Society's Collection. These are:—

1. A nearly white fowl, stated to be a hybrid between a male Guinea-fowl and a domestic hen, from Ceará, Brazil, where it is said that such crosses are often bred and are called Tahý. This bird looks, at first, so much like a common hen that one would be inclined to doubt its alleged parentage until one hears its voice, which is most unmistakably that of a Guinea-fowl. On close examination it also shows a slight coronal helmet and indications of lappets at the gape.

2. A male Curassow (*Crax pinima*) from the upper valley of the Rio Grajahu in the State of Maranhão.

Dr. Goeldi writes:—"This bird will interest you, as it has me, because it quite agrees with the males of '*Mutum pinima*' which were brought to me by the Tembè Indians from the upper valley of the Rio Capim, and, according to my opinion, settles the whole question of *Crax pinima* of Natterer being the hitherto unknown male of the females upon which the Nattererian species was established, which species was afterwards united with *Crax sclateri* Gray. This being the case, the Nattererian *Crax pinima* should now be recognized."

A communication was read from the Rev. O. Pickard Cambridge, F.R.S., stating that as he found that his name *Eatonia*, proposed for a new genus of Acaridea in a paper read on December 14th last (see P. Z. S. 1897, p. 939), had been previously employed for a genus of Brachiopoda (see 10th Ann. Report of New York State Cabinet of Nat. Hist. p. 90), he proposed to substitute for it the new name *Eatoniana*.

CONTENTS (continued).

March 15, 1898 (continued).

	Page
3. Additions to the Knowledge of the Phytophagous Coleoptera of Africa.—Part I. By MARTIN JACOBY, F.E.S. (Plate XXII.)	212
4. On a new Flagellate Protozoon of the Genus <i>Lophomonas</i> . By E. H. J. SCHUSTER, F.Z.S.	242

April 5, 1898.

The Secretary. Report on the Additions to the Society's Menagerie in March 1898	245
Mr. Oldfield Thomas. Exhibition of, and remarks upon, a series of specimens of a Siamese Squirrel showing variability in coloration	245
1. On the Species of the Genus <i>Millepora</i> : a preliminary Communication. By SYDNEY J. HICKSON, M.A., D.Sc., F.R.S.	246
2. On the Perforate Corals collected by the Author in the South Pacific. By J. STANLEY GARDINER, M.A., Gonville and Caius College, Cambridge: (Plates XXIII. & XXIV.)..	257
3. On the Geographical Races of the Banting. By R. LYDEKKER, B.A., F.R.S., F.Z.S. (Plate XXV.)	276
4. Description of a new Dik-dik Antelope (<i>Madoqua</i>) discovered in N.E. Africa by Mr. H. S. H. Cavendish. By OLDFIELD THOMAS, F.Z.S.	278

April 19, 1898.

Mr. E. W. L. Holt. Exhibition of, and remarks upon, some advanced larvæ of the luminous Fish <i>Scopelus glacialis</i>	279
Hon. Walter Rothschild, F.Z.S. Exhibition of a mounted specimen of the Ribbon-fish, <i>Regalecus argenteus</i> (?)	280
Mr. Slater. Remarks on the principal animals observed during recent visits to the Marseilles Garden, the menagerie of the Bey of Tunis at Marsa, and the Jardin d'Acclimatation, Paris	280
1. On the Breeding of the Dragonet (<i>Callionymus lyra</i>) in the Marine Biological Asso- ciation's Aquarium at Plymouth; with a preliminary account of the Elements, and some remarks on the significance of the Sexual Dimorphism. By ERNEST W. L. HOLT. (Plate XXVI.)	281
2. On the Serricorn Coleoptera of St. Vincent, Grenada, and the Grenadines (<i>Malacodermata</i> , <i>Ptinidæ</i> , <i>Bostrychidæ</i>), with Descriptions of new Species. By HENRY S. GORHAM, F.Z.S. (Plate XXVII. figs. 1-5 & 7-10.) ..	315
3. On the Coleoptera of the Families <i>Erotylidæ</i> , <i>Endomychidæ</i> , and <i>Coccinellidæ</i> , collected by Mr. H. H. Smith in St. Vincent, Grenada, and the Grenadines, with Descriptions of new Species. By HENRY S. GORHAM, F.Z.S. (Plate XXVII. figs. 6, 11, 12.)	334
4. Remarks on the Affinities of <i>Palæospondylus gunni</i> . In reply to Dr. R. H. Traquair. By Dr. BASHFORD DEAN	343

May 3, 1898.

The Secretary. Report on the Additions to the Society's Menagerie in April 1898	348
Rev. O. Pickard Cambridge, F.R.S. Note on the generic name <i>Eatonia</i>	348

LIST OF PLATES.

1898.

PART II.

Plate		Page
XIX.	1. <i>Pelmatochromis webwitschi</i> . 2. <i>Chromidotilapia kingsleya</i> ..	132
XX.	Butterflies from Natal	186
XXI.	<i>Cancer pagurus</i> . First Post-larval Stages, magnified	204
XXII.	New species of African Phytophagous Coleoptera	212
XXIII. } XXIV. }	Corals from the South Pacific	257
XXV.	Heads of (1) Burmese and (2) Javan Races of the Banting (<i>Bos sondaicus</i>)	276
XXVI.	<i>Callionymus lyra</i>	281
XXVII.	Serricorn and other Coleoptera from the West Indies	315 & 334

NOTICE.

The 'Proceedings' are issued in *four* parts, as follows:—

Part	I.	containing papers read in January and February, on June 1st.
	II.	„ „ „ „ March and April, on August 1st.
	III.	„ „ „ „ May and June, on October 1st.
	IV.	„ „ „ „ November and December, on April 1st.

PROCEEDINGS

OF THE

GENERAL MEETINGS FOR SCIENTIFIC BUSINESS

OF THE

ZOOLOGICAL SOCIETY

OF LONDON

FOR THE YEAR

1898.

PART III.

CONTAINING PAPERS READ IN

MAY AND JUNE.

OCTOBER 1st, 1898.

PRINTED FOR THE SOCIETY,
SOLD AT THEIR HOUSE IN HANOVER SQUARE.

LONDON:
MESSRS. LONGMANS, GREEN, AND CO.,
PATERNOSTER-ROW.

[*Price Twelve Shillings.*]

LIST OF CONTENTS.

PART III.—1898.

May 3, 1898.

	Page
Mr. Selater. Exhibition of, and remarks upon, some specimens of Mammals from the Gambia, with a List of the Antelopes known from that Colony	349
1. On the Larger Mammals of Tunisia. By Sir HARRY JOHNSTON, K.C.B., F.Z.S.	351
2. On some Pigeons and Parrots from North and North-west Australia. By Prof. R. COLLETT, F.M.Z.S. (Plates XXVIII. & XXIX.)	353
3. Notes on <i>Lepus oiostolus</i> and <i>L. pallipes</i> from Tibet, and on a Kashmir Macaque. By W. T. BLANFORD, F.R.S., F.Z.S.	357
4. On a Collection of Lepidopterous Insects from San Domingo. By EMILY MARY SHARPE. With Field-notes by the Collector, Dr. CUTHBERT CHRISTY	362
5. A List of the Lepidopterous Insects collected by Mrs. Lort Phillips in Somaliland. By EMILY MARY SHARPE	368
6. On a Collection of Insects and Arachnids made by Mr. E. N. Bennett in Socotra, with Descriptions of new Species. By F. A. DIXEY, M.A., M.D., MALCOLM BURE, F.Z.S., and the Rev. O. PICKARD-CAMBRIDGE, M.A., F.R.S., C.M.Z.S. (Plates XXX. & XXXI.)	372

May 17, 1898.

1. On a small Collection of Mammals obtained by Mr. Alfred Sharpe, C.B., in Nyasaland. By OLDFIELD THOMAS, F.Z.S.	391
2. On a Collection of Lepidoptera made in British East Africa by Mr. C. S. Betton. By ARTHUR G. BUTLER, Ph.D., F.L.S., F.Z.S., &c., Senior Assistant-Keeper, Zoological Department, British Museum. (Plates XXXII. & XXXIII.)	397
3. On some Earthworms from British India. By SOPHIE M. FEDARB	441
4. On a new Genus and Species of Rodents of the Family <i>Anomaluridae</i> , from West Africa. By W. E. DE WINTON, F.Z.S. (Plates XXXIV. & XXXV.)	450
5. On the Identification of a Gecko from Penang. By STANLEY S. FLOWER, 5th Fusiliers, F.Z.S.	451

June 7, 1898.

The Secretary. Report on the Additions to the Society's Menagerie in May 1898	457
Mr. L. W. Wigglesworth. Remarks on the Theories of the Origin of Secondary Sexual Characters	457
1. On some Crustaceans from the South Pacific.—Part II. <i>Macrura anomala</i> . By L. A. BORRADAILE, M.A., F.Z.S., Lecturer in Natural Science at Selwyn College, Cambridge. (Plate XXXVI.)	465
2. Report on the Gephyrean Worms collected by Mr. J. Stanley Gardiner at Rotuma and Funafuti. By ARTHUR E. SHIPLEY, F.Z.S., Fellow and Tutor of Christ's College, Cambridge, and University Lecturer in the Advanced Morphology of the Invertebrata. (Plate XXXVII.)	468
3. Fourth Report on Additions to the Batrachian Collection in the Natural-History Museum. By G. A. BOULENGER, F.R.S. (Plates XXXVIII. & XXXIX.)	471
4. Note on an Italian Newt, <i>Molge italica</i> . By M. G. PERACCA, Ph.D., F.Z.S. (Plate XL.) ..	481
5. On some Spiders from Savoy. By the Rev. O. PICKARD-CAMBRIDGE, M.A., F.R.S., C.M.Z.S., &c.	481

June 21, 1898.

Mr. J. Graham Kerr, F.Z.S. Exhibition of specimens of <i>Lepidosiren</i> and other Fishes collected in the Gran Chaco of Paraguay	481
The Secretary. Remarks on the arrival in the Society's Gardens of four living specimens of the Australian Lung-fish (<i>Ceratodus forsteri</i>)	481
Mr. Boulenger. Exhibition of, and remarks upon, specimens of <i>Polypterus lapradii</i> from the Lower Congo	481
Mr. R. E. Holding. Remarks on the Zoological Gardens at Belle Vue, Manchester	481
Prof. Howes. Exhibition, on behalf of Mr. E. W. L. Holt, of a specimen of a new British Fish (<i>Argentina silus</i>)	481
Mr. Abbott H. Thayer. Remarks on his method of demonstrating the underlying principle of protective coloration in animals	481

Contents continued on page 3 of Wrapp

Mr. Sclater exhibited three pairs of horns from the Gambia, kindly sent to him for examination by Sir R. B. Llewelyn, K.C.M.G., Governor of the Gambia. These horns he referred to *Bubalus planiceps*, *Hippotragus equinus*, and *Oreas derbianus*, and called special attention to the fine pair of the last-named animal, which were of large dimensions, measuring 31 inches in length from the base in a straight line and $11\frac{1}{2}$ inches round the base.



Horns of *Oreas derbianus* (Sir R. B. Llewelyn).

Mr. Sclater remarked that modern information was much wanted concerning the Antelopes of this district of West Africa, and that Sir R. B. Llewelyn, the present Governor, had kindly taken much interest in the subject, and had sent him a MS. list of the Antelopes known to him, which were 11 in number. Sir Robert stated that the Derbian Eland, called 'Jinke-janko' by the Mandingos, was rare in the colony, though occasionally found in Niammina in the dry season, but was said to be met with in large quantities on the upper river.

Mr. Sclater also stated that, the Gambia being now so easily accessible by steam every fortnight, "and fairly healthy during the dry season," it was singular that none of our travelling sportsmen

and naturalists had yet found their way there. The Gambia appeared to be just on the boundary between the densely-wooded district of the south and the more open country on the north. The two principal collectors hitherto had been Whitfield, Lord Derby's agent, who brought home examples of many fine species for the Derby Menagerie some fifty years ago; and in more recent days Dr. Percy Rendall, who had presented the Society with their unique specimen of *Cervicapra redunca* in 1890.

From these and other sources we had become aware of the existence of at least 14 species of Antelopes in the Colony, of which the following was a list, with the names of the authorities stated:—

1. BUBALIS MAJOR (Scl. et Thos., Book of Ant. i. p. 11).
Rendall, Carter.
2. DAMALISCUS KORRIGUM (ib. i. p. 59).
Whitfield, Rendall.
3. CEPHALOPHUS RUFILATUS (ib. i. p. 167).
Whitfield.
4. CEPHALOPHUS MAXWELLI (ib. i. p. 179).
Whitfield.
5. CEPHALOPHUS CORONATUS (ib. i. p. 195).
Whitfield.
6. OUREBIA NIGRICAUDATA (ib. ii. p. 23).
Whitfield, Mosse.
7. COBUS UNCTUOSUS (ib. ii. p. 105).
Whitfield, Rendall.
8. COBUS KOB (ib. ii. p. 137).
Whitfield.
9. CERVICAPRA REDUNCA (ib. ii. p. 171).
Whitfield, Rendall.
10. GAZELLA RUFIFRONS (ib. iii. p. 163).
Whitfield.
11. ORYX LEUCORYX (Pall.).
Whitfield.
12. HIPPOTRAGUS EQUINUS (Geoffr.)¹.
Whitfield, Rendall, Llewelyn.
13. TRAGELAPHUS SCRIPTUS (Pall.).
Whitfield, Rendall, Llewelyn.
14. OREAS DERRIANUS (Gray).
Whitfield, Rendall, Llewelyn. (See also Reed, P. Z. S. 1863,
p. 169, pl. xxii.)

¹ Cf. Selater, P. Z. S. 1896, p. 983.

The following papers were read:—

1. On the Larger Mammals of Tunisia.
By SIR HARRY JOHNSTON, K.C.B., F.Z.S.

[Received May 3, 1898.]

Eighteen years ago I spent eight months in Northern Tunisia and lived for some weeks with a French military expedition on the western borderland of that country. A good deal of sport was indulged in by the French and Tunisian officers, and as the result of one day's shooting I was able to picture in a group a Lioness, a Leopard, a Barbary Stag, a number of Wild Boars, a Hyæna, and some Mountain Gazelles. Such a bag would be almost impossible now. Three Lions were killed near our camp in six weeks at the period I refer to (1880). Now the Lion is practically extinct in Tunisia. If any specimens still linger they would be found in the thickly-forested mountains round Ain Draham, in the extreme north-west of the Regency. The Leopard is still found in the wilder parts of Northern and Western Tunisia. The Striped Hyæna is sparsely distributed all over the Regency and right down into the Sahara, though of course it is never found now near any of the big towns. Yet I can remember a Hyæna being killed in the suburbs of Tunis in 1880. The Jackal is, however, abundantly met with: I have seen wild ones running across my garden at Marsa, twelve miles from Tunis. Genets and Ichneumons are met with, and the Arabs constantly speak of a Wild Cat which from their accounts would seem to be *Felis maniculata*.

The Cheetah and the Caracal are occasionally met with in the extreme south of Tunisia, to the south of the salt lakes of the Jerid. I have seen skins of these animals in the possession of Arabs. The Pardine Lynx is found in the wooded mountains. The Barbary Ape is nowhere reported to exist in Tunisia. Arabs—usually Moroccans—often appear in the towns of the Regency with tame Baboons. These they are said to bring from the countries south of Morocco. Three of these animals which I have examined seemed to me to be the Arabian Baboon (*Cynocephalus hamadryas*), hitherto known to us as coming from Nubia, Somaliland, and Arabia—the Baboon of ancient Egyptian art. One of these animals (a female) I purchased from its Moroccan owner, and she is still alive and in my possession. Her former owner stated that she was brought from Sūs, a Sahara country to the south of Morocco. Mr. Sclater, who has seen her, states that she is undoubtedly of the Arabian species. This, however, is a digression from the subject of my present paper, though I think the matter of sufficient interest to be mentioned.

The little Fennec Fox is common in Southern Tunisia; and a Fox scarcely distinguishable from the English form is found in the wooded country.

In the district of Mateur in Northern Tunis there is a rather remarkable herd of Buffaloes—about fifty in number. They are said to be descended from a few domestic Buffaloes of the Indian species presented forty years ago or more by a King of Naples to the Bey of Tunis. They were placed on a property of the Bey's where there is a large swampy lake, in the middle of which rises a mountainous island. Here they have resumed the feral state, and, judging from several heads I have seen, are developing much longer horns than those of the domestic Buffalo of Italy. These creatures are now strictly preserved by the Bey, and it is useless to ask for permission to shoot them, as it is always withheld.

The Bubaline Antelope (*Bubalis bosclaphus*) formerly found in Tunisia is now quite extinct there, I hear, though it is still found in Southern Algeria and in the Tripolitaine. It must have extended its range once into Central or even Northern Tunisia, judging by the frequency of its appearance in Roman frescoes and mosaics. I am informed by a German naturalist, Mr. Spatz, that in the districts where it still lingers in Tripoli it affects plateaux with a fair amount of vegetation, rather than the sandy desert which is the home of the Addax. The Hartebeest is known to the Arabs by the name of Bagar-al-hamra—"the Red Cow."

The Addax (*Addax naso-maculatus*) is still a Tunisian animal, though it is rarely heard of now north of the limits of the real sandy desert. In my recent journey into the Tunisian Sahara I saw a fresh-killed head brought in by an Arab, and found the horns and skins abundant and cheap as articles of purchase. In this manner I obtained two fine specimens of male horns and one very good female head. I saw in the possession of a French officer—and drew for the 'Book of Antelopes'—a pair of male Addax horns which attained a third complete turn. The horns of the female have only one turn or twist, are much slenderer and more curved in general outline, and altogether more oryginic in appearance. Yet they suggest, as do those of the male still more strikingly, an equal affinity to the immature male and to the female horns of the Sable Antelope. The Addax, I think, is on the whole more an oryginic type than a hippotragine, but it probably branched off from the parent stock of both groups not long after they—in my opinion—developed from the Cobus group through some form like *Cobus marica*.

In the Tunisian Sahara the Arabs report the existence of a true Oryx—seemingly *Oryx leucoryx*. A small specimen of this Antelope (immature) is to be seen—stuffed—in the Bey's Natural History Collection at the Marsa near Tunis. It is also remarkable that the Oryx is represented as a Tunisian animal in the Roman frescoes and mosaics now preserved in the Bardo Museum.

The Udad, or Barbary Wild Sheep, is still common in the mountains of Southern Tunisia. The Barbary Stag is found in some abundance in the well-wooded mountains of the West, along the Algerian frontier. It is now carefully protected by the French and has begun to revive in numbers, having been once nearly extinct.

Three species of Gazelles seem to be found in Tunis—I have seen them all, either alive or dead: the Common Gazelle (*Gazella dorcas*), the Mountain Gazelle (*G. cuvieri*), and Loder's Gazelle (*G. loderi*).

The creatures represented in the numerous Roman mosaics and frescoes include—besides most of those mentioned—the Ostrich (now extinct in Tunisia) and the African Elephant. The latter is represented unmistakably. But there is no reason why it may not have been imported from Numidia (modern Algeria) rather than have been at that time a mammal indigenous to the relatively bare plains of Tunisia, where it would miss the necessary forests.

It will be remembered that Harmo, the Carthaginian, who made an expedition along the Morocco coast in about 520 B.C., records having seen large herds of Elephants in the R. Tensift, not far from the present capital of Morocco.

2. On some Pigeons and Parrots from North and North-west Australia. By Prof. R. COLLETT, F.M.Z.S.

[Received April 7, 1898.]

(Plates XXVIII. & XXIX.)

Dr. Knut Dahl, a young Norwegian naturalist who, during the years 1894–95, lived in North and North-west Australia, and occupied his time in collecting objects of natural history for the Zoological Museum at Christiania, returned home in the spring of 1896 with a valuable collection of vertebrates and invertebrates. The Mammals of this collection have already been worked out¹, and Mr. G. A. Boulenger has given an account of some new *Sauria*² contained in it.

On a preliminary examination of the considerable collection of birds, I found, amongst the *Psittaci* and *Columbeæ*, examples of three species hitherto not described, of which I append short descriptions, together with some remarks on one or two other interesting forms.

The localities in which these species were found are Arnhem Land (North Australia)³ and Roebuck Bay, situated somewhat further to the south (North-west Australia).

1. PETROPHASSA ALBIPENNIS Gould (1840).

Petrophassa albipennis, Salvadori, Cat. B. Br. Mus. vol. xxi. p. 530 (1893).

One specimen from Victoria River, 4th April, 1895 (sex unknown).

¹ Collett, "On a Collection of Mammals from North and North-west Australia" (Proc. Zool. Soc. Lond. 1897, p. 317, with plate).

² Boulenger, "Descriptions of four new Lizards from Roebuck Bay, N.W. Australia, obtained by Dr. Dahl for the Christiania Museum," Ann. Mag. Nat. Hist. ser. 6, vol. xviii. Sept. 1896.

³ A few short remarks on these localities are given in Proc. Zool. Soc. Lond. 1897, pp. 317–318.

Length of wing 137 millim. ; length of tail 123 millim.

To the descriptions of Mr. Gould (Handb. B. Austr. vol. ii. p. 141) and Salvadori (Cat. B. Br. Mus. vol. xxi.) may be added, that the feathers encircling the eye are whitish, and that the outer webs of the primaries from 2nd to the 6th have metallic lustre. The under wing-coverts are chocolate-brown.

But few specimens of this species were observed, as a rule single birds. They inhabited the broken sandstone ranges which are met with at the mouth of Victoria River (a little to the south of Arnhem Land). The preserved specimen was shot at Blunder Bay, near the outlet of the river in Queen's Channel.

2. *PETROPHASSA BUFIPENNIS*, sp. nov. (Plate XXVIII.)

Two specimens, adult males, from South Alligator River, 19th June, 1895.

Length of wing *a*, 150 millim. ; *b*, 152 millim.

„ „ tail *a*, 146 „ „ *b*, 149 „

This species is easily distinguished from *P. albipennis* by its much greater size, by the chestnut primaries having black tips and margins, by the pale grey centres to the feathers of the head and neck, and by the whitish throat.

Descr. Head and neck greyish brown, each feather with whitish centre ; throat yellowish white, unspotted. Lores black ; a whitish narrow line above and below the eyelids.

All the upper surface and chest rufous brown ; each feather margined with rufous ; the centre of the feathers of the chest greyish white.

Abdomen and under tail-coverts (as in *P. albipennis*) chocolate-brown. No metallic spot on the upper wing-coverts, and on one of the secondaries, as in that species.

Primaries chestnut-red, with the tips and outer web blackish, the latter with a slight metallic lustre. The under wing-coverts rufous brown, those of the primaries being more chestnut.

Tail rufous brown on the upper surface, chocolate-brown (with a slight bluish gloss) underneath.

Bill and feet as in *P. albipennis*.

Hab. This Pigeon was met with in flocks in the central portions of Arnhem Land about the sources of the South Alligator River. It inhabits the stony parts of the sandstone hills ; it lies close amongst the stones, and knows well how to conceal itself amongst them when wounded.

3. *PTILOPUS (LEUCOTRERON) ALLIGATOR*, sp. nov. (Plate XXIX.)

Two specimens, male and female, from South Alligator River, 15th June, 1895.

Length of wing Male 184 millim. ; female 189 millim.

„ „ tail „ 142 „ „ 141 „

Nearest to *P. cinctus* from Timor. It differs, however, in having



J.G. Keulemans del. et lith.

PETROPHASSA RUFIPENNIS.

Mintern, Bros imp







J.G. Keulemans del. et lith.

Mintern Bros. imp.

PTILOPUS (LEUCOTRERON) ALLIGATOR.

the rump grey, very broad whitish tips to the tail-feathers, and in the lower breast, belly, and under tail-coverts being grey.

One of the specimens is a male, the other a female; if no confusion exists, the female is a trifle larger than the male. The colours are much alike in both, but in one (male) the secondaries have their outer webs brownish black, with very narrow white edgings. The first primary in one of the specimens (male) abruptly attenuated, in the other more gradually so. The 5th and 8th primaries are broad and obliquely notched at the tips, as in *Ducula*, with the outer web longer than the inner.

Descr. Head and upper neck white; lower neck and chest whitish cinnamon; mantle slate-black; lower back greyish black; rump and upper tail-coverts clear grey, the latter inclining to whitish. Lower parts ashy grey, separated from the chest by a broad black band on the lower breast, sharply defined against the chest. Wings slate-black, lower surface of the quills grey, the coverts more greyish brown. Tail slate-black; with an apical greyish-white band about one and half inches in breadth; under surface of the tail clearer grey; under tail-coverts whitish. Bill (in skin) light-coloured, the tips yellowish, feet reddish.

Hab. The two specimens of this bird were shot while with a flock which was seated feeding in a Bonjon tree (a sort of *Ficus*). They were never seen except in the region near the sources of the South Alligator River in Arnhem Land. Their flight was very noisy. Their food consists mainly, according to native report, of the fruit of the said Bonjon tree, the figs of which are not bigger than the berries of the mountain ash.

4. CALYPTORHYNCHUS STELLATUS Wagl. (1832).

Calyptorhynchus stellatus, Salvadori, Cat. B. Br. Mus. vol. xx. p. 111 (1891).

One specimen, adult female, Roebuck Bay, North-west Australia, 20th November, 1895.

Length of wing 378-380 millim.; tail 244; culmen 40; genys 26.

The only specimen secured is a female. It differs from the females of the larger species (*C. banksi* and *macrorhynchus*) in being wholly black (bluish black above, more greenish below), without spots or bars. The tail resembles that of the female of the larger species, the feathers having the coloured parts mingled with yellow and scarlet; the lower wing-coverts are spotted. The bill is blackish, with paler margins.

The question as to whether the nearly-allied forms of black Cockatoos—*C. banksi* (Lath.), 1790, *C. macrorhynchus* Gould, 1847, and *C. stellatus*, Wagl. 1832—are to be regarded as distinct and separate species, does not appear as yet to have been cleared up.

The University Museum at Christiania possesses several specimens of the larger forms, three of them having been obtained in Queensland by Dr. Lumholtz in June 1882 (two males and a female).

In addition to these, three specimens (two females and one male) were collected by Dr. Dahl in 1894-95 in three different parts of Arnhem Land (S. Alligator River, Mt. Showbridge, and Howard Creek).

There is no observable difference between the specimens from Queensland and N. Australia as regards size, colouring, length of the crest, length of the wings, tail, &c., the bill alone being considerably larger in all three specimens from N. Australia than that of those from Queensland, as will be seen from the sub-joined measurements:—

Specimens from Queensland.

Female	Culmen	45 millim.;	genys	30 millim.
Male	„	46 „	„	32 „
„	„	51 „	„	34 „

Specimens from N. Australia.

Male	Culmen	55 millim.;	genys	37 millim.
Female	„	55 „	„	35 „
„	„	56 „	„	36 „

As regards the present specimen of *C. stellatus*, the difference in the size of body between it and the larger species is striking. On the other hand, the difference in the size of the bill is comparatively less when compared with the specimens from Queensland.

On account of insufficient materials, it is impossible to determine whether the unspotted body in the present female is an invariable and specific characteristic by which this species can be separated from the larger species (in which the females are known to be always spotted).

Hab. Dr. Dahl did not meet with *C. stellatus* in separate flocks, but only in the company of the larger species.

The preserved specimen was shot amongst *C. macrorhynchus*, which appears everywhere throughout Arnhem Land, where it was, as a rule, seen in flocks of about six individuals. Likewise in the neighbourhood of Roebuck Bay (further to the southward) these large black Cockatoos were numerous, and assembled in great flocks, especially during the dry season, at those spots where water was to be found. Many were shot as food for the expedition.

Amongst these flocks of *C. macrorhynchus* there were occasionally seen individuals which appeared to be smaller than the others, and which might be assumed to have been *C. stellatus*.

5. PSEPHOTUS DISSIMILIS, sp. nov.

Four specimens (one male, three females), from Mary River, Arnhem Land, May 1895.

The male and one female are fully grown, with rather worn plumage; two other females are younger, freshly moulted.

Nearest to *P. chrysopterygius* Gould, 1857, but lacks the yellow band across the forehead; the crown is chestnut, the lower parts

are verditer-blue (in the male), the under tail-coverts orange. The sexes are different in coloration.

Male . . .	Wing	123	millim.;	tail	167	millim.
Female ..	„	118	„	„	?	„
„ ..	„	118	„	„	150	„
„ ..	„	121	„	„	148	„

Adult male. Forehead, lores, and crown dark chestnut; cheeks and ring across the nape and all the lower parts verditer-blue; the abdomen more greyish and without any trace of scarlet. Lower tail-coverts orange. Back of neck, back, scapulars, inner wing-coverts, and inner secondaries light greyish brown. Rump bluish green; upper tail-coverts yellowish green with faint bluish edges. A large patch on the anterior, smaller, and median wing-coverts, yellow; greater wing-coverts and quills black, the latter slightly edged with a bluish tint; edge of the wing verditer-blue; under wing-coverts of a more bluish hue. Two central tail-feathers olive-green at the base, passing into brownish black towards the extremity; next pair bluish green with whitish tips, and the inner web blackish; the remaining tail-feathers light bluish green, crossed by an irregular blackish band. Bill (in skin) bluish horn-colour with whitish edges; feet brownish grey.

Adult female. Crown and forehead greyish olive-green, cheeks more grey. Upper surface, wing-coverts, and breast yellowish green; abdomen light bluish green. Rump, upper and under tail-coverts, and tail as in the male; under surface of the quills with an oblong yellow spot; edge of the wing greenish; under wing-coverts dark greyish green. Bill dark, as in the male.

Younger female. Like the adult female, but the crown a little more yellowish green (like the back), with the front greyish; sides of the head clear grey, with faint stripes of emerald-green. Bill yellowish.

Hab. This Parrot was met with here and there in small flocks in Arnhem Land, particularly between Pine Creek and Catherine River, but did not appear to be common. It was seen only during the dry season. It possesses a singular jarring cry, and, like all Parrots, is reluctant to forsake a wounded companion.

Christiania, March 15, 1898.

3. Notes on *Lepus oiostolus* and *L. pallipes* from Tibet, and on a Kashmir Macaque. By W. T. BLANFORD, F.R.S., F.Z.S.

[Received April 14, 1898.]

In Büchner's magnificent work on the Mammalia collected by Przewalski¹ in Central Asia many important changes are introduced into the nomenclature formerly employed by myself and others, and several of the species described by Dr. Günther and

¹ Wissenschaftliche Resultate der von N. M. Przewalski nach Central Asien unternommenen Reisen &c. Zoologischer Theil. Band I. Säugethiere.

myself from the collections made by the members of the 2nd Yarkand Mission are referred to forms previously named by Russian writers. In most cases there can be no hesitation in accepting conclusions formed from a far larger series of specimens and with the advantage of access to types; and even in some instances, in which I feel doubt as to whether Büchner's views are right, I have not now the specimens of the Stoliczka Collection nor any other Central Asiatic skins available for reference.

There is, however, one case in which I can, I think, give reasons for not agreeing with Büchner, and it is important that this particular point should be cleared up, both because the species concerned are found within British Indian limits, and were described by a British author, and because the identification depends on specimens and drawings in London collections. Moreover, I feel bound to deal with the matter because I have, as Büchner very justly remarks, omitted to publish the evidence on which my own final conclusions were formed—the volume on Mammalia of the 'Fauna of British India,' in which they appeared, being unsuited for the discussion of details.

This case relates to the Hares named *Lepus oiostolus* and *L. pallipes* by Hodgson. The first was described in 1840¹, the second in 1842². It is unnecessary to enter at any length into the history of these forms except to say that in 1879³ I pointed out that the type of *L. oiostolus* was a very young animal, and in 1891⁴ I united the two supposed species after examining thoroughly the evidence existing. Büchner, in 1894, after showing that in Hodgson's original description of *L. oiostolus* nothing was said of the species being founded on young animals, and that, on the contrary, all the details appeared to have been taken from adults⁵, proceeded to identify with *L. oiostolus* a rather large Hare from high elevations in Northern Tibet and in Kansu (Ganssu), a smaller species from the same region being regarded by him as *L. pallipes*.

I am quite aware that nothing has been published by Hodgson to show that the name of *L. oiostolus* was given to young specimens; indeed it is far from certain that Hodgson was aware at the time that the skins originally described by him came from immature animals⁶, though, as I shall presently show, he appears to have ascertained subsequently that this was the case.

¹ J. A. S. B. ix, p. 1186.

² J. A. S. B. xi, p. 288, pl.

³ Scientific Results 2nd Yarkand Miss., Mam. p. 63.

⁴ Fauna Brit. Ind., Mam. p. 452.

⁵ "Ich möchte aber noch die Bemerkung vorausschicken, dass das Material, welches Hodgson bei Aufstellung seiner Art vorgelegen hat, ein, wie er selbst angiebt, nur defektes war; dass aber dieses Material jungen Thieren angehörte (wie dieses Blanford annimmt) wird von ihm nicht erwähnt und ist auch von der Beschreibung nicht zu ersehen; es sprechen im Gegentheile alle Angaben dieser Beschreibung dafür, dass die Originale erwachsene Thiere waren."—Büchner, *l. c.* p. 205.

⁶ The following was Hodgson's original description, *l. c.* pp. 1185, 1186:—

"Of the Tibetan species I possess only some wretched remains which enable me to indicate the species thus:

"*Lepus oiostolus*, with fur consisting almost wholly of wool, considerably

I will proceed to give the evidence on which I founded my statement that the type or types of Hodgson's *L. oiostolus* were immature.

The only original specimen in the British Museum, marked as the type, is a skin about 8 inches in length, and consequently of an animal not nearly half-grown. But I am of opinion that this cannot be the original type of Hodgson's description, for not only is the size very much less than that of *L. ruficaudatus*, but moreover the colour is not slaty-grey blue, and the fur is not distinctly woolly. It is of course possible that the fur may have been originally slaty-grey blue and that it has faded, but this is not very probable. At the same time it is quite possible, and even probable, that this young Hare is a very young *L. pallipes*. A skin of an older but still immature *L. pallipes* from Northern Sikkim, received from the late Mr. Mandelli and now in the British Museum, does, however, agree admirably with Hodgson's description of *L. oiostolus*, so much so that I believe the description to have been drawn, as Hodgson says, from "some wretched remains" of a skin or skins resembling that procured by Mandelli.

This view is confirmed by Hodgson's MS. notes. As is well known, the drawings presented by Hodgson to the British Museum were copies of his original figures; these figures were subsequently given by him to the Zoological Society, and they are invaluable on account of the MS. notes written on them by Hodgson himself. Amongst these original drawings there is one of *L. oiostolus*, in a crouching position. This drawing is small (about $3\frac{1}{2}$ inches long) and shows scarcely any characters except a greyish colour and woolly fur. No notes are attached. This drawing does not resemble the specimen said to be the type in the British Museum. There are two drawings of *L. pallipes*—one of these the original of the excellent plate in the Journal of the Asiatic Society of Bengal, vol. xi. p. 289, and on the back of the sheet with these drawings are the following notes in Hodgson's handwriting:—"1, 2, 3 [the numbers evidently refer to different skins]. Various skins from Tibet; animal on the whole not larger than *ruficaudatus*, but seems to have a larger head and shorter ears, but perhaps not so. Size cannot be greater, for teeth smaller, nails of same size, and legs, of which bones entire, quite equal. Comparing *oiostolus* and *pallipes*, apprehend they are the same. Specimen 1 of latter last described (see Journal 124¹ of 42), sp. 2 doubtful, sp. 3 got in Sikkim from [illegible] April." "It is moulting and shows new fur coming on back. This new fur in the hairy piles is $1\frac{1}{4}$ inch long,

curved and interspersed rarely with very soft hairs. Slaty grey blue for the most part and internally, but externally fawn-tinted above, and whitish below and on the limbs; some hairs on the back tipped with black beneath a sub-rufous ring. Tail white with a grey-blue strip towards the back. Apparent size of the last (*L. macrotus=ruficaudatus*). *Habitat*, the snowy region of the Himalaya and perhaps also Tibet."

¹ That is No. 124, the number of the part of Jour. As. Soc. Beng. in which the description of *L. pallipes* appeared in the year 1842.

very fine, slightly wavy. Basal half almost hoary; apical half has 3 equal rings, 2 black and, between them, a pale ruddy one. The shorter woolly piles are hoary, tipped with clear pale brown, and this is only seen in old fur, making the colour above brown. Rump and *basal strip above of tail blue*" [the italics are mine], "all the piles being wholly of that hue (pale slaty); rest of tail rufescent white, all below more or less tinted rufous, palest and white almost under head and mid-belly and buttocks [a few words here are confused and doubtful]; outside limbs the ruddy tint clearer and deeper and on front of neck, but no black-tipped hairs. Paws darker ruddy. Head above darkest, most of hairy piles [sentence doubtful] of outer surface of ears as turned back colour like head above, of inner surface and nape rufescent white, large black tips to ears, moustaches half black half white."

Lower down in pencil, also by Hodgson, is a note, referring apparently to yet another specimen. It runs thus:—

"Another young seems to prove that *oiostolus* is young of *pallipes* or this¹. About 14 [inches] from snout to vent" [other skins varied from 19 to 23]. There is a longish description of which only the following requires quotation:—"As to colour, very little of rufous or of black, above slaty-blue shaded with hoary, more or less rufescent on body and clearly so on neck, shoulders, and a bit down fore limbs to ends. Buttocks pure slaty, head grey; of the outsides of ears the exterior half is white from base to tip and the interior darkish grey like head above."

I cannot see how, with the above evidence, there can be any other conclusion than that the name *L. oiostolus* was given to an immature specimen or to immature specimens of the species subsequently named *L. pallipes*. That *L. oiostolus* cannot be, as Büchner supposes, the larger species of the two is manifest from Hodgson's remark on p. 288 of J. A. S. B. vol. xi. He there says that *L. oiostolus* is not so common in the Central and Eastern Provinces of Utsang and Kham as the *next and much larger species* (*L. pallipes*).

What, then, is the larger Hare identified by Büchner with *L. oiostolus*? In Southern Tibet, at high elevations, there are found two Hares, one large, the other of moderate size—*L. hypsibius* and *L. oiostolus* (*L. pallipes*). It is probable that the two Hares inhabiting similar lofty plateaux in Northern Tibet are identical or closely allied, and the smaller species is identified by Büchner with that found on the Himalayan frontier of the Tibetan highland. From the description also it is manifest that the Hare identified by Büchner with *L. oiostolus* resembles *L. hypsibius* in size, in its very thick woolly fur, and generally in colour; the only important exception being that the northern form has on the

¹ I do not understand what is meant by 'or this,' unless Hodgson thought he had included more than one species under *L. pallipes*. In his Catalogue of Mammals of Nepal, published in the Calcutta Journal of Natural History, ii. (1842) p. 220, five new species of *Lepus* are mentioned, but as only *macrotus* and *diastolus* (*oiostolus*) are specified, the 5 may be one of the numerous misprints occurring in the list.

upper surface of its tail a distinct narrow blackish stripe¹ tinged with grey, which is wanting in *L. hypsibius*. The skull, too, judging from a comparison of Büchner's figures (pl. xxv. figs. 6-8) with my own (pl. iv. a, figs. 1, 1 a, 1 b), is very similar except that the nasals in the North Tibetan skull are rather longer. Some apparent divergencies in the printed measurements are evidently due to different methods of taking the dimensions. Both skulls agree in one very striking character, the elevation of the post-orbital processes on each side above the plane of the frontals, and the resulting concavity of the frontal area.

I think it is by no means improbable that the large Hare of North Tibet and Kansu, identified by Büchner with *L. oiostolus*, is a variety of *L. hypsibius*. If not, it must, I think, be an undescribed species.

On *Macacus rhesus villosus*.

In the Proceedings of the U. S. National Museum, vol. xvii. pp. 1-16 (1894), is a paper by Mr. Frederick W. True entitled "Notes on Mammals of Baltistan and the Vale of Kashmir, presented to the National Museum by Dr. W. L. Abbott." I am indebted to the author for a copy. Three species of *Arvicola* are described as new, and a grey form of *Mus arianus* as a new subspecies. A Monkey is called *Macacus rhesus villosus*, and is regarded as a new subspecies of *M. rhesus*.

This last is by far the most interesting addition to the Kashmir fauna. Five specimens, all males, and three of them adults, were obtained in Lolab, which lies N.W. of the western extremity of the Walar Lake, and about 20 miles north of Baramula.

Mr. True says that at first he supposed the specimens to represent *M. assamensis*, but after a careful comparison with Anderson's description of the type of that species, he was convinced that they were not the same. He omits to point out the differences.

Now there are three characters by which *M. assamensis* (*M. pelops* Hodgs.) may be distinguished from *M. rhesus*. In the former the face is dusky, the hair is wavy or woolly, and the buttocks are clad with hair around the callosities. Every one of these three characters is possessed by *M. rhesus villosus*. Moreover there is not, so far as I know, any other characteristic difference in skins. I am unable to come to any other conclusion than that the *M. rhesus villosus* is identical with *M. assamensis*. The Kashmir Monkey is, I think, certainly *M. pelops*, and Anderson, who examined the types of both, united *M. pelops* and *M. assamensis*.

If the *Macacus* of Lolab is *M. assamensis*, it is probable that

¹ Büchner's identification of the Hare with *L. oiostolus* appears to be chiefly due to the presence of this grey stripe on the upper surface of the tail, as he quotes Hodgson's description, "tail white with a grey-blue strip towards the back." It is probable that Hodgson's expression has been understood to imply the presence of a stripe along the whole dorsal surface: I am satisfied, however, that by "towards the back" he meant the extreme base of the tail; see the previous description from his MS. of *L. pallipes*—words italicized.

the Monkeys occurring near Murree and Abbottabad are the same. I have never been able to obtain a specimen. A few years ago a scene was figured in one of the principal illustrated newspapers in which these Monkeys played a conspicuous part, but as they were represented with prehensile tails it was evident that either the imaginative powers of the artist, or the supposed tastes of the British public as interpreted by the newspaper editor, had deprived the picture of any value as evidence.

4. On a Collection of Lepidopterous Insects from San Domingo. By EMILY MARY SHARPE. With Field-notes by the Collector, Dr. CUTHBERT CHRISTY.

[Received March 10, 1898.]

The present collection was made during the year 1896 by Dr. Christy in the Island of San Domingo. He has entrusted me with the determination of the species, among which will be found a fine new Hesperid.

Dr. Christy's stay in the island was not long enough for him to obtain an extensive series of specimens, but his notes on the habits of the species will, I think, be found to be interesting. The best paper on the Lepidoptera of San Domingo is that of Ménétrés, in the third volume of the *Nouv. Mém. Soc. Imp. Nat. de Moscou* (1831).

I have taken most of the names from the collection in the British Museum, and have especially consulted the 'Biologia' of Messrs. Godman and Salvin. I have also to thank my friend Mr. W. F. Kirby for his kind assistance in determining the specimens.

Family DANAIIDÆ.

1. ANOSIA ARCHIPPUS (Fabr.).

[Seen commonly from February to May both at Sanchez and La Vega. On one occasion in February, whilst on a shooting trip in the big morass at the mouth of the Yuna river, I found quantities of these insects frequenting certain dried mud-banks. They were very conspicuous on account of the three beautiful tufts or pencils of hair, fully three-eighths of an inch long, which they were able to extrude at will from the extremity of the abdomen. I tried many ways to get the tufts to remain extruded after the insects were killed, but was not successful.—C. C.]

Family SATYRIDÆ.

2. CALISTO HYSIUS (Godt.).

[By far the commonest Butterfly in San Domingo while I was there.—C. C.]

Family HELICONIIDÆ.

3. HELICONIUS CHARITHONIA (Linn.).

[Common. Noted also in the island of St. Thomas in January. It is peculiarly moth-like in its habits and flight, frequenting dim and shady places, flying backward and forward through the bushes, slowly and aimlessly but with the wings moving fairly quickly. Generally two are seen together. When repeatedly struck at, this insect will fall down through the bushes like a dead leaf.—*C. C.*]

4. LYCOREA CLEOBÆA (Hübner.).

[Four specimens taken in February.—*C. C.*]

Family NYMPHALIDÆ.

5. COLÆNIS DELILA (Fabr.).

[A common insect in the garden during February, March, and April, becoming hardly recognizable, owing to its battered condition, towards April.—*C. C.*]

6. AGRAULIS VANILLÆ (Linn.).

[Very common at Sanchez during February and March, settling on the flowers in the garden. Like *A. delila*, it becomes hardly recognizable in April, owing to its battered condition. It is a quick-flying insect.—*C. C.*]

7. ANARTIA IATROPHÆ (Linn.).

[One of the most abundant species of all during February, March, and April, both at Sanchez and La Vega. It flies low and frequents the roadsides and clearings everywhere.—*C. C.*]

8. CYSTINEURA TELEBOAS (Ménétr.).

[The only occasion upon which I observed this species was in April, on the mountain side near La Vega, where I discovered a small party of five amongst some bushes, about 2 feet high. They never left the cover of these bushes and flew with such a slow, weak flight that, even at a distance of 2 or 3 feet, they were difficult to distinguish, unless the bushes and grass were absolutely still. I took two of them in a collecting-bottle, without using the net.—*C. C.*]

9. ANARTIA DOMINICA Skinner.

[Not common. Only five specimens taken during February, March, and April.—*C. C.*]

10. AGERONIA FERENTINA (Godt.).

[Not noticed before April. Then pretty common at La Vega. A most wary and difficult insect to catch, and costly, for I was always breaking my net over it. I met with it usually on the trunks of trees, basking in the sun with its wings extended flat

upon the mottled grey bark, which it exactly resembles in colour and markings. When disturbed it flies rapidly to the next trunk and disappears, and it is only after a prolonged examination of the bark that it is seen again, in the same position with its wings open but higher up the tree. The least movement of the net and away it goes again.—*C. C.*]

11. *TIMETES CHIRON* (Fabr.).

[Not noticed before May, then met with in the mountains near La Vega, frequenting open stony places or patches of wet shingle by the side of the Yuna river, in parties of three or four.

This Butterfly is exceedingly difficult to take. One swoop of the net and the whole party has vanished like magic. Although struck at each time they will return to the same spot over and over again. After expending a deal of energy on several occasions I only managed to obtain one specimen.—*C. C.*]

12. *VICTORINA STENELES* (Linn.).

[Not noticed before April. Then fairly common at La Vega. A quick and high-flying insect, frequenting any open glade or favourite hedge and offering battle to any large insect, or even a small bird, that may come near. The pugnacity and strength of wing of this species is extraordinary, and even when it has to fly with hardly "a stitch of canvas set" its impudence is undiminished. A perfect specimen must be a great rarity.—*C. C.*]

13. *APATURA THOE* (Godt.).

[One specimen caught in April. The only one met with.—*C. C.*]

Family *LICENIDÆ*.

14. *TARUCUS MONOPS* Zeller.

[Very common during March and April.—*C. C.*]

15. *TARUCUS CASSIUS* (Cram.).

[Not common. Two specimens taken in February and one in April.—*C. C.*]

Family *PIERIDÆ*.

16. *DISMORPHIA SPIO* (Godt.).

[One specimen brought to me in April.—*C. C.*]

17. *EUREMA MIDEA* (Ménétr.).

[Very common at La Vega in April, flitting over the savañas and open grassy places.—*C. C.*]

18. *EUREMA LISA* (Boisd.).

[Possibly as common as *E. midea*, but I was unable to distinguish them on the wing. Two of the four specimens taken in February at Sanchez.—*C. C.*]

19. *EUREMA PATMIRA* (Poey).

[A common insect at La Vega in April, frequenting the same open grassy places as *E. midea*.—*C. C.*]

20. *XANTHIDIA HYONA* (Ménétr.).

[Seen only occasionally. Four specimens taken during April at La Vega. Frequents the same open grassy places as *Eurema midea*.—*C. C.*]

21. *PIERIS ALBUSTA* (Sepp).

[Taken occasionally during February, March, April, and May, at both Sanchez and La Vega.—*C. C.*]

22. *DAPTONURA SALACIA* (Godt.).

[One specimen only, caught on an open mountain-slope near La Vega in April.—*C. C.*]

23. *CALLIDRYAS SENNÆ* (Linn.).

[A very common insect. Specimens taken during February, March, April, and May. One of the sights of the forest-railway between Sanchez and La Vega is the immense clouds, consisting of thousands of males and females of this species, to be seen occasionally as the train nears La Vega. They are usually collected over some culvert or expanse of half-dried mud, and fly in such a compact mass that on one occasion I could see them distinctly a mile and a half away, measured by the telegraph-posts.—*C. C.*]

24. *CALLIDRYAS THALESTRIS* (Hüb.).

[A common insect, but difficult to take owing to its power on the wing. The clouds of *C. sennæ* always contained a small portion of *C. thalestris*.—*C. C.*]

25. *RHABODRYAS TRITE* (Linn.).

[Not noticed before April. Then not uncommon in the garden at La Vega, settling always upon scarlet flowers.—*C. C.*]

26. *TERICOGONIA TERISSA* (Lucas).

[One specimen only, caught in the garden at La Vega during May.—*C. C.*]

Family P A P I L I O N I D Æ.

27. *PAPILIO POLYDAMAS* Linn.

[One specimen taken in April at La Vega.—*C. C.*]

28. *PAPILIO POLYCAON* Cram.

[Two specimens taken at La Vega during April, on a bitter-orange tree. Seen twice at Sanchez during March, also frequenting the young orange-trees.—*C. C.*]

29. *PAPILIO MACHAONIDES* Esper.

[Taken at La Vega whilst flitting slowly amongst the branches of a small bitter-orange tree.—*C. C.*]

30. *PAPILIO ZETES* Westw.

[One specimen taken at La Vega in April.—*C. C.*]

Family *HESPERIIDÆ*.31. *EUDAMUS SIMPLICIUS* (Stoll).

[One specimen taken at La Vega in April.—*C. C.*]

32. *EUDAMUS PROTEUS* (Linn.).

[Specimens taken in February and April. They seemed to be very partial to the edges of streams or marshy places, settling on the water-plants or on the half-dried mud.—*C. C.*]

33. *EUDAMUS DORANTES* (Stoll).

[Pretty common during April in the garden at La Vega, but also partial to water, like *E. proteus*.—*C. C.*]

34. *PHOCIDES PYRES* Salvin.

[One specimen taken in April near La Vega in amongst thick forest growth.—*C. C.*]

35. *PROTEIDES IDAS* (Cram.).

[Common at La Vega in April.—*C. C.*]

36. *ACOLASTUS AMYNTAS* (Fabr.).

[One poor specimen taken at La Vega in April.—*C. C.*]

37. *TELEGONUS HABANA* (Lucas).

[Two specimens taken in April near La Vega amongst dense forest growth. Seen two or three times flying along the edges of the forest, and settling on some conspicuous twig or the under surface of some large leaf.—*C. C.*]

38. *TELEGONUS CHRISTYI*, sp. n.

Nearest to *T. alardus*, Stoll, but is at once distinguished from that species by the narrow transparent band of white on the primaries.

Primaries. More than half the wing is brownish black, the basal area strongly marked with bright metallic steel-blue. About the middle of the discoidal cell is a narrow transparent band of white broken by the dark nervules; this band commences from the costal margin extending to the first discoidal nervule.

Secondaries. A broad brownish-black marginal border, the basal area bright metallic blue.

Head and thorax metallic green.

Underside. Dark brown, suffused with a violaceous shading.

There is a bright metallic-blue patch in the discoidal cell on the primaries, extending as far as the white transverse band.

Palpi deep yellow, this colour extending down the centre of the thorax, but becoming narrower towards the abdomen.

Expanse 2·2 inches.

[One specimen taken in dense forest on the mountains near La Vega in April. Settled on the under surface of a large leaf.—*C. C.*]

39. *ACHLYODES FLYAS* (Cram.).

[One poor specimen taken at La Vega in May.—*C. C.*]

40. *EANTIS PAPINIANUS* (Poey).

[Two specimens taken in April at La Vega.—*C. C.*]

41. *HESPERIA SYRICHTUS* Fabr.

[A very common species indeed during February and March.—*C. C.*]

42. *ADOPÆA THAUMAS* (Hufn.).

[One specimen taken at Sanchez in February.—*C. C.*]

43. *OCHLODES PUSTULA* (Hübner).

[One specimen taken at Sanchez in February.—*C. C.*]

44. *HYLEPHILA PHYLÆUS* (Drury).

[One specimen taken at La Vega in April.—*C. C.*]

45. *PHEMIADES UTHA* (Hew.).

[Fairly common at La Vega in April.—*C. C.*]

46. *CALPODES ARES* (Feld.).

[One specimen taken at La Vega in April.—*C. C.*]

LEPIDOPTERA HETEROCERA.

Family SPHINGIDÆ.

47. *DILOPHONOTA ELLO* (Linn.).

48. *THERETRA TERSA* (Linn.).

Family ZYGENIDÆ.

49. *EMPYREUMA LICHAS* (Cram.).

50. *COSMOSOMA AUGÆ* (Linn.).

Family ARCTIIDÆ.

51. *ECPANTHERIA DECORA* Walker.

52. *EUCHÆTES INSULATA* (Walker).

53. *DEIOPEIA SPECIOSA* Walker.

Family NOCTUIDÆ.

54. ANOMIS ARGILLACEA (Hübner).
55. LAPHYGMA MACRA (Guenée).
56. ATETHMIA SUBUSTA Hübner.
57. BOMOLOCHA EXOLETALIS Guenée.
58. PALTHIS ARCASALIS.
59. PALINDIA sp.
60. GONODONTA HESIONE (Drury).
61. PEOSINA NUMERIA (Drury).
62. BLOSYSIS VATES (Guenée).
63. LETIS MYCERINA (Cramer).
64. PAOPHILA IMMUNIS (Guenée).
65. PAOPHILA GARNOTI (Guenée).
66. PAOPHILA OBLIGATA (Walker).
67. REMIGIA REPANDA (Fabricius).
68. THERMESIA GEMMATALIS (Guenée).
69. CAPNODES RUFINANS Guenée.
70. PERIGEA CIRCUITA Guenée.

Family GEOMETRIDÆ.

71. NEPHELOLEUCA POLITIA (Cramer).
72. ÆSCHROPTERYX ONNUSTARIA Hübner.
73. BOARMIA OPPOSITARIA Walker.
74. APLODES CONGRUATA (Walker).
75. NEDUSIA MULTILARIA Hübner.
76. THYSANOPYGA APICITRUNCARIA Herr.-Sch.

Family PYRALIDÆ.

77. PYRAUSTA PHENICEALIS Hübner.
78. PYRAUSTA PHYLLISALIS (Walker).
79. DESMIA UFEUS (Cramer).
80. ZINCKENIA PERSPECTALIS Hübner.

81. *PHRYGANODES SIMILIS* (Guen.).
 82. *PHRYGANODES PROLONGALIS* (Guen.).
 83. *GLYPHODES HYALINATA* (Linn.).
 84. *SYLLEPTA ELEVATA* (Fabr.).
 85. *SYLLEPTA INTERNITALIS* (Guen.).
 86. *SYLLEPTA HECALIALIS* (Walker).
 87. *PILOCROCIS INFUSCALIS* (Guen.).
 88. *PACHYZANCLA ÆGROTALIS* Zeller.
 89. *SAMEODES CANCELLALIS* (Zeller).

Family C R A M B I D Æ.

90. *PLATYTES PUSILLALIS* (Hüb.).
 91. *DICYMOLOMIA PEGASALIS*.

5. A List of the Lepidopterous Insects collected by Mrs. Lort Phillips in Somaliland. By EMILY MARY SHARPE.

[Received March 12, 1898.]

I have again had the pleasure of working out Mrs. Lort Phillips's collection of Butterflies, made during her second expedition to Somaliland in the first three months of 1897. In this collection are examples of many interesting species, including two novelties belonging to the family *Lycenidæ*.

Name.	Locality and Date.
Fam. DANAIDÆ.	
1. <i>Limnas klugii</i> Butler	Dobar, Woria Ballambal, Jan. 26th; Sangamore, March; Bihen.
Fam. SATYRIDÆ.	
2. <i>Ameocera maderakal</i> (Guér.) ...	Rugga Pass, March.
3. <i>Ypthima doleta</i> Kirby	Bihen, Jan. 23rd; Wagga, 6000 ft., Feb. 20th.
Fam. ACRÆIDÆ.	
4. <i>Acræa chilo</i> Godman	Wagga, Feb.; Rugga Pass, March; Hanka-deely, March 7th.
5. <i>Acræa bræsia</i> Godman	Rugga Pass, March.
Fam. NYMPHALIDÆ.	
6. <i>Junonia clelia</i> (Cram.)	Dobar; Bihen, Jan. 23rd; Hammar, Feb. 27th.

Name.	Locality and Date.
Fam. NYMPHALIDÆ (cont.).	
7. <i>Junonia cebrene</i> Butler	Bihen, Jan. 23rd; Hammar, Jan. 27th.
8. <i>Precis taveta</i> Rogenh.	Wagga Mountain, 6000 ft., Feb. 20th; Rugga Pass, March.
9. <i>Precis sesamus</i> Trimen	Hammar, Jan. 27th.
10. <i>Byblia ilithyia</i> Drury	Hankadeely, March; Wagga, 6000 ft.; Hammar, Jan. 27th.
11. <i>Hypolimnas misippus</i> (Linn.) ..	Bihen, Jan.
12. <i>Charaxes hansalii</i> Feld	Wagga, 6000 ft., Feb. 28th.
Fam. LYCENIDÆ.	
13. <i>Axiocerces perion</i> (Cram.)	Bihen, Jan. 25th; Sangamore, March.
14. <i>Lycæna patricia</i> Trimen	Wagga, March 3rd.
15. <i>Lycæna jesus</i> Guér.	Upper Sheikh, Jan. & Feb.
16. <i>Lycæna knysna</i> Trimen	Somaliland.
17. <i>Lycæna trochilus</i> (Frey.)	Hammar, Feb. 27th; Gedais, 4300 ft., Feb. 16th.
18. <i>Tarucus louisæ</i> , sp. nov.	Wagga Mountain, 6000 ft., February; Dobar, Jan.
19. <i>Tarucus theophrastus</i> Fabr. ...	Dobar,
20. <i>Lycænesthes amarah</i> Lefebv. ...	Somaliland.
21. <i>Lycænesthes princeps</i> Butler ...	Upper Sheikh, Feb. 1st.
22. <i>Deudorix livia</i> (Klug)	Sogsoda, Feb. 11th; Hammar, Jan. 27th.
23. <i>Tatura philippus</i> (Fabr.)	Hankadeely, Feb. & March.
24. <i>Tatura mimosa</i> Trimen	Sogsoda, Feb. 11th.
25. <i>Spindasis somalina</i> Butler ...	Wagga, Feb. 28th.
26. <i>Spindasis waggæ</i> , sp. nov. ...	Wagga Mountain, 6000 ft., Feb.
27. <i>Argiolauts silas</i> Westw.	Wagga, 6000 ft.; Upper Sheikh, Feb. 1st.
Fam. PIERIDÆ.	
28. <i>Terias ceres</i> Butler	Rugga Pass, March; Gedais, Feb. 17th.
29. <i>Pieris infida</i> Butler	Wagga, 6000 ft., Feb.; Hankadeely, March 7th; Somaliland.
30. <i>Pieris gidica</i> Godt.	Wagga, Feb. 13th; Upper Sheikh, Feb. 1st; Sogsoda, Feb. 11th; Bihen, Jan. 25th.
31. <i>Mylothris agathina</i> (Cram.) ...	Wagga, Feb. 7th.
32. <i>Colias electra</i> (Linn.)	Wagga, Feb.
33. <i>Teracolus calais</i> (Cram.)	Dobar, Jan. 21st.
34. <i>Teracolus chrysonome</i> (Klug) ...	Rugga Pass, March.
35. <i>Teracolus arne</i> (Klug)	Wagga, Feb.
36. <i>Teracolus omphale</i> Godt.	Wagga, March 3rd.
37. <i>Teracolus ignifer</i> Butler	Wagga.
38. <i>Teracolus evagore</i> (Klug)	Wagga, Feb. 14th.
39. <i>Teracolus evenina</i> (Wallengr.) ..	Bihen, Jan. 25th.
40. <i>Teracolus thruppi</i> Butler	Rugga Pass, March; Upper Sheikh, Feb. 1st.
41. <i>Teracolus evarne</i> (Klug)	Wagga, Feb. 13th; Gedais, Feb. 16th; Sogsoda, Feb. 11th; Upper Sheikh, Jan. 28th; Bihen, Jan. 25th.
42. <i>Teracolus philipsi</i> Butler	Bihen, Jan. 25th.
43. <i>Teracolus heliocautus</i> Butler ...	Rugga Pass, March.
44. <i>Teracolus eupompe</i> Klug	Wagga, March 3rd; Upper Sheikh, Jan. 30th.
45. <i>Teracolus pseudacaste</i> Butler ..	Sogsoda, Feb. 5th.

Name.	Locality and Date.
Fam. PIERIDÆ (cont.).	
46. <i>Teracolus lorti</i> E. M. Sharpe .	Wagga Mountain, 6000 ft., Feb. 20th.
47. <i>Teracolus protomedia</i> (Klug). .	Upper Sheikh, Feb. 1st; Sogsoda, Feb. 5th & 6th.
48. <i>Synchlœ glauconome</i> (Klug)...	Bihen, Jan. 24th.
49. <i>Euchlœ falloni</i> Albard	Wagga, 6500 ft., March 2nd; Wagga, Feb. 23rd; Rugga Pass, March.
50. <i>Catopsilia florella</i> (Fabr.)	Sogsoda, Feb. 11th; Rugga Pass, March.
51. <i>Herpœnia melanarge</i> Butler ...	Upper Sheikh, Jan. 31st.
Fam. PAPILIONIDÆ.	
52. <i>Papilio demoleus</i> (Linn.)	Wagga Mountain, Sogsoda, Feb. 11th.
53. <i>Papilio pseudonireus</i> Feld. ...	Hankadeely, March 7th.
Fam. HESPERIIDÆ.	
54. <i>Rhopalocampta anchises</i> Godt.	Sogsoda, Feb. 5th; Dobar, Jan. 7th.
55. <i>Sarangesa pertusa</i> (Mabille)...	Rugga Pass, March; Wagga, March.
56. <i>Pyrgus vindex</i> Cram.	Somaliland.
57. <i>Hesperia diomus</i> Hopff.	Wagga, Feb. 20th; Rugga Pass, March.
Fam. LIMACODIDÆ.	
58. <i>Parasa vivida</i> Walker	Rugga Pass.
Fam. NOCTUIDÆ.	
59. <i>Heliothis armigera</i> W. Y.....	Rugga Pass, March.
Fam. LIPARIDÆ.	
60. <i>Stilpnotia crocipes</i> Boisd.	Wagga, Feb. 20th.
Fam. LITHOSIIDÆ.	
61. <i>Secusio parvipuncta</i> Hamps... .	Wagga, Feb. & March.
62. <i>Deiopeia pulchella</i> Linn.	Rugga Pass; Wagga; Upper Sheikh, Jan. 30th.
Fam. GEOMETRIDÆ.	
63. <i>Sterranthia sacraria</i> (Linn.)...	Wagga, March 3rd.

The following are the descriptions of the two new species represented in the collection:—

18. *TARUCUS LOUISÆ*, sp. nov.

Black with white markings.

♂.—*Primaries*. Brownish black with faint indications of darker spots, these representing the markings on the underside.

Secondaries. Similar to the primaries; near the hind margin is a submarginal line of narrow white spots, followed by a row of black spots; above this is a second inner row of five white spots, commencing from the posterior angle, and extending to about the middle of the wing. Fringe on both wings white.

Underside. Ground-colour of both wings white, relieved by

numerous spots and bands of black as in *T. sybaris* Hopffer, the black zigzag bands on the primaries being rather more heavily indicated.

Expanse 0·7 inch.

♀.—Similar to those of *T. sybaris* and *T. theophrastus* (Fabr.), but differing in the white discal patch on the primaries being much more reduced. Expanse 0·6 inch.

26. *SPINDASIS WAGGÆ*, sp. nov.

Nearest to *S. namaquus* Trimen as regards the colouring of the underside, and is at once distinguished by the absence of any blue on the upper surface.

♂.—*Primaries*. Uniform brown, suffused with bronze, two black spots, the first being at the end of the discoidal cell, the second nearer the base. A narrow black submarginal line, followed by a white fringe on the hind margin.

Secondaries. Similar to the primaries, but having no bronze shading. Near the posterior angle is a bright orange spot, closely followed by four nearly obsolete spots of white for about half the length of the narrow black submarginal line.

Underside. Ground-colour brown with pearly white spots, suffused with silver and outlined with black. These spots are distributed over both wings, and do not form any regular bars or rows of spots, with the exception of a submarginal row of white spots preceding the hind marginal border. The orange spot on the secondaries is divided by a silver dot, having near the inner margin a distinct black spot.

Expanse 1·1 inch.

♀.—Similar to the male, but is rather larger, and the bronze colour is a little deeper, and is extended to the secondaries. The orange spot is also not quite so bright.

Expanse 1·2 inch.

6. On a Collection of Insects and Arachnids made by Mr. E. N. Bennett in Socotra, with Descriptions of new Species. By F. A. DIXEY, M.A., M.D., MALCOLM BÜRR, F.Z.S., and the Rev. O. PICKARD-CAMBRIDGE, M.A., F.R.S., C.M.Z.S.

[Received March 29, 1898.]

(Plates XXX. & XXXI.)

CONTENTS.

- I. Lepidoptera. By F. A. DIXEY, p. 372.
 II. Orthoptera. By MALCOLM BÜRR, p. 384.
 III. Insects of other Orders. By several Contributors, p. 386.
 IV. Arachnida. By O. PICKARD-CAMBRIDGE, p. 387.

I. LEPIDOPTERA, with Remarks on Local and Seasonal Forms in the Genus *Byblia* Hübn. By F. A. DIXEY, M.A., M.D., Fellow of Wadham College, Oxford.

Mr. E. N. Bennett, a Fellow of Hertford College, Oxford, reached Socotra on December 17, 1896, in company with the

late Mr. Theodore Bent and Mrs. Bent. During their visit they traversed the island from Ghalansyah in the west to Ras Momi in the east, and thence, after a long circuit to the south-west, returned to Tamarida on the north coast. The party left the island on February 11th, 1897. Interesting personal accounts of the expedition will be found in the 'Nineteenth Century' for June 1897, by Mr. Bent; and in the volume of 'Longman's Magazine' for 1897, by Mr. Bennett. The whole of their sojourn in the island came within the period of the N.E. monsoon. Atmospheric conditions were persistently dry, especially on the plains; in the mountains there was a heavy dew every morning, which soon dried in the sun. Very little rain fell at any time, and the thermometer never sank below 60° F. Exactly 100 specimens of insects and arachnids, which are now in the Hope Museum, Oxford, were collected by Mr. Bennett.

The Rhopalocera consist of 52 specimens, belonging to 15 species, two of which appear to be new to science. Of these 15 species, 9 were also taken by Professor Bayley Balfour, F.R.S., during his visit to Socotra between February 11th and March 30th, 1880¹. The only one of Professor Balfour's captures not represented in the present collection is *Charaxes balfouri* Butl.

DANAINÆ.

LIMNAS CHRYSIPPUS Linn. (Nos. 1, 2.)

Two specimens; ♂ and ♀. These are paler than the average of African examples, bearing in this respect a greater resemblance to specimens from India. The white spots forming the subapical band are in both, but especially in the male, unusually small and discrete. Some African specimens show the same character, but rarely in so pronounced a form². The Socotran male has most of the veins in the hind wing, especially the branches of the median, thickly covered with white scales, which also extend to narrow adjacent areas of the wing, and form a ring around the black patch marking the position of the submedian scent-gland. A trace of the same white colouring of veins and adjacent areas is also visible in the female. This is a first approximation to the condition seen in var. *alcippoides*, Moore, where, however, the veins themselves often retain their brown colour in the midst of the whitened area of the hind wing. It is noticeable that both the Socotran specimens are in fine condition, though the collection as a whole has suffered much from the attacks of beetle larvæ.

"Seen only in the hills, flying strongly. Not common."—*E. N. B.*

¹ See Proc. Zool. Soc. 1881, pp. 175-180, pl. xviii.

² A pair from Aden in Coll. Brit. Mus. closely resemble the Socotran examples in this respect, and also in the general ground-colour. A female specimen from Aden in Coll. Hope, of the same ground-colour, also shows an approach to the discrete condition of the subapical white spots. Prof. Balfour's Socotran specimen, a female, has like Mr. Bennett's pair a pale ground-colour, but the subapical spots are less discrete. It is curious that specimens of *L. chrysippus* in Coll. Brit. Mus. from Athens, Turkey, and Syria are as dark as the ordinary form from Africa.

ACRÆINÆ.

ACRÆA NEOBULE Doubl. (Nos. 10-15.)

Acraea neobule Doubl.; Butler, Proc. Zool. Soc. 1881, p. 177, pl. xviii. fig. 5.

Six specimens; probably all females, but in one the abdomen is missing. These resemble *A. neobule* from the African mainland, but the powdering of black scales at the apex of the fore wing is much more distinct, and there is little or no admixture of brown or reddish scales with the black of the apex, as generally occurs in *A. neobule*. In all six examples the ground-colour is deeper in tone, and the dark border of the hind wing is broader and has a smoother outline than in average specimens of *A. neobule*, while the pale spots in the dark border are on the upperside either not present or comparatively indistinct. All the black spots on the hind wing are relatively larger than in normal *A. neobule*; they are also more uniform in size; the two spots which occur one on each side of the discoidal vein, usually very small in *A. neobule*, are here less different in bulk from the other dark spots of the wing. The abdomen in these specimens is black with spots of the pale ground-colour, as in *A. hortæ* Linn. A female *A. neobule*, brought from Socotra by Prof. Bayley Balfour, has a perceptible powdering of reddish scales at the apex of the fore wing, but in other respects resembles Mr. Bennett's specimens. It was noted and figured in 1881 by Mr. Butler (*loc. cit.*), who, however, refrained from giving it a specific name in the absence of further examples. From the present series it seems probable that the differences from normal *A. neobule* are fairly constant, but not sufficiently so to warrant separation. It is worth remarking that in Reiche's figure of *A. neobule* from Abyssinia¹ the border of the hind wing is comparatively narrow, denticulate, and furnished with large light-coloured spots, while the apex of the fore wing appears to be powdered with red. The specimen represented differs therefore considerably from Mr. Bennett's series.

"Mostly seen in the hills, at an elevation of about 2000 feet. Not hard to get, the flight being slow and bold."—*E. N. B.*

SATYRINÆ.

CALYSISME ANYNANA Butl. (Nos. 3-7.)

Mycalopsis anynana Butl. Ann. Nat. Hist. (5) iii. (1879), p. 187.

Calysisme socotrana Butl. Proc. Zool. Soc. 1881, p. 175, pl. xviii. fig. 7.

Five specimens; 3 ♂, 2 ♀. Two of the males and one of the females are much worn. The iris of the large ocellus on the underside of the fore wing, which is whitish in the male described

¹ Ferr. et Gall., 'Voy. en Abyss.' iii. p. 466, pl. 33. fig. 3. See Trimen, 'South Afr. Butt.' vol. i. 1887, p. 138.

by Butler (P. Z. S. 1881, p. 175), is in two of the present males, including the best preserved of the three, distinctly orange as in the female. The size of all the smaller ocelli on the under surface seems to vary in both sexes. The upper surface of the hind wing carries in the male the glandular patch and tuft of hairs which are characteristic of the genus (Moore, Lepid. Ceylon, 1880-81, p. 20). The under surface of the dorsal border of the fore wing, where it overlaps the hind wing, is similarly clothed in the male with pale and glistening scales, forming a pearly patch. Five specimens of *C. anynana* in Coll. Brit. Mus. from the Island of Johanna (Comoro Group) are apparently "wet-season" forms; but another specimen from the same locality and one from Zanzibar seem to be "dry-season" forms and are indistinguishable from Socotran examples.

"The commonest butterfly in the island, inhabiting plains and mountains alike. A ground-haunting species, apt to take cover. Never flying high, and always easy to catch."—*E. N. B.*

NYPHALINÆ.

BYBLIA BOYDI, sp. n. (Nos. 16-22.) (Plate XXX. figs. 1 ♂, 2 ♀.)

Hypanis cora Feisth.; Butl. Proc. Zool. Soc. 1881, p. 177, pl. xviii. fig. 4.

Types (♂ and ♀) in Hope Museum, Oxford.

Seven specimens; 4 ♂, 3 ♀. Distinguishable from the "dry-season" form of *B. götzius* Herbst and *B. anvatara* Boisd. by the following particulars:—(1) The area of fulvous ground-colour lying between the black submarginal band and the oblique median black patch on the disc of the fore wing is in *B. boydi* divisible into two portions, separated by a pair of black denticulations which almost meet one another along the course of the first median branch. Of these two portions, *the posterior is conspicuously narrower than the anterior*, the narrowing being caused mainly by the encroachment outwards of the oblique median patch. The outline of this latter patch in the allied forms tends rather sharply inwards between the first median branch and the dorsal border, but in *B. boydi* it is continued to the dorsal border at such an angle as to preclude the fulvous area from expanding again posteriorly, as it does in normal *B. götzius*. (2) *A chain of small black spots* is more or less visible, crossing the fulvous median area of the hind-wing upperside. These spots, which correspond to a series constantly present in *B. ilithyia* Drury, are only rarely indicated in *B. götzius*. The above characters appear to be constant and distinctive. One or more of the following features may be found in specimens of *B. götzius* from various localities on the mainland, but they do not occur all together except in *B. boydi*, where the combination appears to be constant:—(1) The black costal bar of the fore wing is continued across the wing to meet the submarginal black band. (2) The fulvous submarginal spots of the hind-wing upperside are large,

subconical, and only slightly separated by the black-coloured veins. (3) All the black markings of the upperside are highly developed, especially the submarginal band of the hind wing, which encroaches considerably inwards. In the presence of the chain of small median dark spots and in the large size of the fulvous submarginal spots of the hind wing, *B. boydi* approaches *B. ilithyia*; in other respects it is much nearer *B. götzius*. The combination of characters above given renders the Socotran form easily recognizable among its allies, and seems to justify its separation as distinct. I have given it the name *boydi*, after the Principal of Hertford College, to whom Science in Oxford is under great obligations.

“Very common everywhere, hills and plains. Not conspicuously ground-haunting.”—*E. N. B.*

Remarks on Geographical and Seasonal Forms in the Genus Byblia Hübn.—*Byblia götzius* Herbst (= *Hypanis acheloia* Wallengr.; = *H. ilithyia* var. A, Trimen, S. Afr. Butt. vol. i. 1887, p. 264) is probably entitled to distinct specific rank beside *B. ilithyia* Drury¹. Each form, as pointed out by Trimen (*loc. cit.* p. 266) and by Barker (Trans. Ent. Soc. Lond. 1896, p. 415), has its own range of seasonal variation. This is also shown by good series of both the *ilithyia* and the *götzius* (or *acheloia*) forms in the British Museum and in the Hope Collection at Oxford. For a large proportion of these each collection is indebted to Mr. G. A. K. Marshall, whose specimens all bear such ample data with regard to locality, altitude, and exact time of capture, as to throw much light upon questions of local and seasonal modification.

The geographical distribution of the two forms is interesting. The *ilithyia* form, with some local variation in size and in the relative proportions of dark markings to fulvous ground-colour, is found in India, Ceylon, Arabia, and the greater part of Wallace's "East African" subregion, including the West African coast districts lying northwards from the River Gambia and southwards from the Congo. It also extends for some distance into the South African subregion, occurring commonly in the Transvaal and Natal highlands, and coming, though rarely, down to the sea at Durban. Its distribution is therefore mainly Indian and "East African" in Wallace's sense². The *götzius* form, on the other hand, is absent from India and from a large portion of "East Africa." It is found at Sierra Leone, Cape Coast Castle, Lagos, Old Calabar, and the coast districts of the Gaboon and the Congo; but outside the limits of Wallace's West African subregion, *i. e.* in Senegal to the north and Angola to the south, it is replaced by typical *ilithyia*. Beginning again on the south-east coast, about the easternmost districts

¹ The evidence on which Mr. Marshall decides against their specific distinctness appears to me to require confirmation. See Marshall in *Ann. Mag. Nat. Hist.* 1896, xviii. p. 338.

² Wallace, 'Geographical Distribution of Animals,' 1876, vol. i. pp. 251, 258 and map.

of the Cape Colony¹, it becomes very common at Durban, and follows the coast-line northwards, occurring at the mouths of the Zambesi, in Mozambique, and at Wasin. Though it seems to be rarely if ever met with in the "South African" interior, it passes inland up the Zambesi and is found in Matabeleland and at Zomba on the Shiré; while the British Museum also contains specimens from Nyasaland, Lake Mvéru, Tanganyika, the Victoria and Albert Nyanza, Wadelai, the Galla country, Abyssinia, Somaliland, and Aden. Like *B. ilithyia*, it shows some amount of local variation which may perhaps justify the specific separation of certain geographical forms².

It appears therefore that, so far as is known, the distribution of the two species (or varietal groups) is fairly distinct, though their respective ranges coincide for a small portion of the South African subregion and to a larger extent in "East Africa," as at Wadelai, in Somaliland, and at Aden. It is further evident that while the distribution of the *ilithyia* form is continuous from India throughout the "East African" subregion, that of the *götzius* form is almost if not quite discontinuous, its area being separated into a western and an eastern division. In the light of these facts it is remarkable that the Socotran form is most closely akin, not to the *ilithyia*, but to the *götzius* type, nearly resembling in fact West African specimens of *B. götzius*, from which it is separated geographically by the whole width of Wallace's East African subregion. It is further of interest to note that the Madagascar and Comoro Islands form (*B. anvatara* Boisd.), though no doubt distinct, is also a modification, not of *B. ilithyia*, but of *B. götzius*³. *B. ilithyia*, being found at such distant points of the "East African" subregion as Senegal, Angola, and Somaliland, as well as in Arabia, India, and Ceylon, might well have been expected to be the form occurring in Socotra; and the fact that it is here replaced by a form of *B. götzius* suggests the possibility that this island, like the South African subregion, and Madagascar with the Mascarene group, contains relics of a more ancient African fauna that has been expelled or excluded from the bulk of the mainland by the great irruption of forms of life which is believed to have taken place from the north-east⁴.

¹ It is implied by Mr. Marshall (*loc. cit.* p. 337) that this Southern race of *B. götzius* (to which he restricts Wallengren's name *acheloia*) occurs also in the Western districts of South Africa, where, he states, the Cunene River (north of Damaraland) appears to be its northern boundary.

² Mr. Marshall (*loc. cit.* pp. 337, 338) recognizes three local races—the Southern (*acheloia* Wallgr., of which *vulgaris* Butl. is the wet-season form), the Western and Central African (*götzius* Herbst), and the North-eastern (*castanea* Butl.). Prof. Bayley Balfour's Socotran examples of *B. boydi*, noted by Butler as *Hypanis cora* Feisth., are rather curiously ranked by Mr. Marshall under var. *acheloia* Wallgr.

³ Trimen, *South Afr. Butt.* vol. i. 1887, p. 267.

⁴ Wallace, 'Geographical Distribution,' 1876, vol. i. p. 218, &c. Prof. Bayley Balfour (*Proc. Roy. Instit.* vol. x. 1884, p. 296) discusses the affinities of Socotran with West and South African plants, and observes that "Socotra indeed is, with Madagascar, to be regarded as the remains of a greatly advanced

The variations of the underside of the hind wing in both forms, *B. ilithyia* and *B. götzius*, have been well described by Trimen (*loc. cit.* pp. 265, 266). They are undoubtedly seasonal, as pointed out by Barker (*Trans. Ent. Soc. Lond.* 1895, p. 415), and by Marshall in the MS. notes and labels accompanying the series in the Hope Collection above referred to, as well as in the *Annals & Mag. Nat. Hist.* 1896, xviii. p. 333, &c. The deeply ferruginous hind wing, on which the three creamy bands stand out conspicuously, belongs in each case to the dry-season form, and there are several intermediate grades leading up to the dull ochreous yellow of the wet-season form. In addition to the points noted by Trimen, it may be remarked that in the wet-season form of *B. götzius* the black submarginal band of the hind wing is relatively broader, and the proximally adjacent strip of ochreous ground-colour narrower, than in the wet-season form of *B. ilithyia*. In the former, indeed, the band of ground-colour is often reduced to a mere chain of fulvous dots with dark edging, forming a proximal border to the dark submarginal band. The pairs of whitish internervular spots on the dark band are also much less regular and conspicuous than in *B. ilithyia*. In the dry-season forms the veins crossing the median creamy band are in *B. götzius* often traced out with the deep ferruginous tint of the ground-colour, which marking has the effect of dividing the median creamy band into spots; this is not seen in *B. ilithyia*. In *B. götzius* also the dark submarginal band seems never entirely to disappear, even in extreme dry-season forms, as it may do in *B. ilithyia*. It soon, however, loses the whitish internervular spots, which in the wet-season form are already less distinct than in *B. ilithyia*.

The Socotran *B. boydi* resembles most specimens of *B. götzius* from the West African subregion in having the dark costal bar of the fore wing continued rather heavily across the wing to join the submarginal band. This is also more or less the case with two females of *B. götzius* from Abyssinia and specimens of the same from Somaliland and Aden in the British Museum; but in examples from South and East Africa the connection between the costal and the submarginal dark bands is often slight or absent. On the other hand, in the submarginal series of spots of the fulvous ground-colour on the upperside of the hind wing, the Socotran form comes nearer to specimens of *B. götzius* from Somaliland, Aden, and the Galla country than to any I have seen from West

African coast-line at a remote period." Messrs. Sclater and Hartlaub (*Proc. Zool. Soc.* 1881, p. 167) point out that *Drymaca hesitata*, one of Prof. Balfour's Socotran birds described by them, is most closely allied to a form inhabiting Madagascar. Col. Godwin-Austen (*Proc. Zool. Soc.* 1881, p. 252) considers that the land-molluscan fauna of Socotra affords "strong evidence that the island was once directly connected with Madagascar to the south"; and adds that "it is not unreasonable to suppose that in Socotra, the Seychelles, Madagascar, and Rodriguez we have the remnants of a very ancient more advanced coast-line on this western side of the Indian Ocean."

Africa. The spots in question are in *B. boydi*, as in the British Museum specimens of *B. götzius* from the localities last named, larger, closer together, more conical, and less quadrate than in individuals from West or South Africa, though in dry-season forms from Natal and East Central Africa an approach is made to the Socotran condition. The dark submarginal band of the hind wing in *B. boydi* is broader than in most specimens of *B. götzius* from E. and S. Africa, whether "wet" or "dry" (the narrower band belonging generally to the "dry" form). It is much broader than in the specimens of *B. götzius* from Somaliland, Aden, and the Galla country above referred to, but not, perhaps, much broader on the average than in the female specimens from Abyssinia.

The present examples of *B. boydi*, like Prof. B. Balfour's pair, are all dry-season forms. In at least two of the seven (both males), as also in both Prof. Balfour's specimens, the whitish internervular spots on the dark submarginal band of the hind-wing underside have disappeared, and in one of these the patches of ground-colour immediately adjacent to the pale median band are obsolescent. The wet-season form of *B. boydi* is still unknown. To judge by the analogy of *B. götzius*, its upper surface must be still more heavily marked with black than that of the specimens collected by Prof. Balfour and Mr. Bennett.

PYRAMEIS CARDUI Linn. (Nos. 8, 9.)

2 ♀. This species was also observed by Prof. Balfour.

"Common everywhere. The three most abundant species, in order of frequency, were (1) *Calysime anynanu*, (2) *Byblia boydi*, (3) *Pyrameis cardui*."—*E. N. B.*

JUNONIA CLELIA Cram. (Nos. 23-28.)

Six specimens; 2 ♂, 4 ♀: two of the latter in a battered condition. These do not differ in any definite manner from specimens from the mainland and the Comoro Islands¹. They are "dry-season" forms, the colouring of the hind-wing underside being fairly uniform and the ocelli obsolescent. This species was not obtained by Prof. Balfour.

"Very common in the mountains."—*E. N. B.*

HYPOLIMNAS MISIPPUS Linn. (Nos. 29-32.)

4 ♀. These are of the ordinary form, showing no tendency towards var. *alcippoides* Butl. They have suffered much from the attacks of larvæ. Not obtained by Prof. Balfour.

"Fairly common; commoner than *L. chrysippus*. Chiefly in the hills. Flight strong."—*E. N. B.*

¹ In *J. epiclelia* Boisd., from Madagascar, the size of the creamy-white markings of the upperside is much reduced, but I doubt whether the other features mentioned by Trimen (*loc. cit.* p. 216) are constant points of difference from *J. clelia*.

LYCÆNINÆ.

TARUCUS THEOPHRASTUS Fabr. (No. 33.)

1 ♂. This species has a wide range throughout the Indian and Ethiopian regions and the Mediterranean subregion of the Palæarctic. It does not occur in Prof. Balfour's collection.

ZIZERA LYSIMON Hübn. (Nos. 34-37.)

Lycæna lysimon, Trimen, South Afr. Butt. vol. ii. 1887, p. 45.

Four specimens; apparently 3 ♂ and 1 ♀. This species also was not obtained by Prof. Balfour.

"Found commonly everywhere, both hills and plains, but chiefly the former. Flight always close to the ground."—*E. N. B.*

A Lycænid collected by Riebeck, who visited Socotra soon after Prof. Balfour, was not determined¹.

PIERINÆ.

BELENOIS ANOMALA Butl. (No. 38.)

Synchlœ anomala Butl. Proc. Zool. Soc. 1881, p. 178, pl. xviii. fig. 3.

One ♀. The specimen is broken, but less worn than the type, which is also a female. The large black spot at the end of the cell in the fore wing, subquadrate in the type, is here rather subtriangular, with the base directed inwards, and showing on both surfaces a slight proximal indentation. On the under surface the outer border of the fore wings is greyish shot with pink, not semitransparent as in the type.

Mr. Butler (*loc. cit.*) assigns this form to the genus *Synchlœ*, but adds that "the possession of a male specimen would satisfactorily decide whether or not it is an unusually aberrant *Beleinois*." The male is still unknown; the venation, however, is unmistakably that of *Beleinois*, as the 1st subcostal branch in the fore wing is concurrent with the costal (cf. *B. mesentina*, *B. creona*, *B. gidica*, &c.), while the upper discocellular is straight and forms an open angle with the lower. There can be little doubt that this interesting species comes nearest to *B. abyssinica* Luc., the dry-season form² of *B. gidica* from the African mainland.

"Rare; only met with in the Haghier Range, at an altitude of about 2300 ft. In the same place another white butterfly of corresponding size was seen, with circular black spots [perhaps the male]. Both flew fast."—*E. N. B.*

TERACOLUS NIVEUS Butl. (Nos. 39-42.)

Teracolus niveus Butl. *loc. cit.* p. 177, pl. xviii. fig. 1.

Teracolus candidus Butl. *loc. cit.* p. 179, pl. xviii. fig. 2.

One ♂, three ♀. The male and one female correspond with

¹ Taschenberg, *Zeitschrift für Naturwiss.* Bd. lvi. 1883, p. 182.

² See Barker, *Trans. Ent. Soc. Lond.* 1895, p. 419.

Butler's *T. niveus*; another female is more heavily marked; the third female agrees with his *T. candidus*. In the male a few yellow and orange scales form a minute speck proximally, adjacent to the black dot at the end of the cell on the underside of the hind wing. A similar yellowish speck occurs in the females, but tends towards the costal rather than the proximal aspect of the dot.

Dr. Butler now considers his *T. niveus* to be the wet-season and *T. candidus* the dry-season form of the same species. In reference to the faunistic affinity between Socotra and the Mascarene group (*supra*, p. 377), it is of interest to note that *T. aldabrensis* Holl., from Aldabra, appears to be the nearest relative of the Socotran *T. niveus*¹.

"The male was taken on Dec. 19th in the sandy coast-plain of Ghalansyah. It was rescued from the jaws of a lizard."—*E. N. B.*

CATOPSILIA FLORELLA Fabr. (Nos. 43-46.)

Catopsilia pyrene Swains.; Butl. Proc. Zool. Soc. 1881, p. 178.

Four specimens; 1 ♂, 3 ♀. The male and two of the females are much worn.

"Only seen in the plain of Tamarida. Flight strong."—*E. N. B.*

PAPILIONINÆ.

PAPILIO BENNETTI, sp. n. (Nos. 47, 48.) (Plate XXX. fig. 3.)

Type in Hope Museum, Oxford.

Two specimens, both probably ♂, but the abdomen of one is imperfect. These resemble *P. demoleus* Linn., from the African mainland, but may be distinguished by the following characters:— (1) On the upper surface all the yellow markings are much reduced in size, and the second spot from the dorsal border of the yellow median chain in the fore wing is more or less Z-shaped, instead of being irregularly rhombic as in *P. demoleus*. (2) There is a broad black area of almost uniform width between the median and the submarginal chains of yellow spots on the fore wing. The corresponding area in *P. demoleus* is comparatively narrow, and conspicuously denticulated in consequence of the relatively large size of the median yellow spots. (3) On the under surface the pale submarginal spots of the hind wing are quadrate, or even elongated in a direction at right angles to the border of the wing; whereas in *P. demoleus* they tend to be oblong, with the long diameter parallel to the hind border. The same applies to the series of rudimentary eye-like marks immediately proximal to the yellow submarginal row. Another feature which is probably distinctive is the fact that in the eye-like mark within the cell on underside of the hind wing the blue edging with its accompanying buff crescent extends only along the posterior side of the triangular black patch, instead of being continued along two sides, the posterior and the dorsal, as in *P. demoleus*. An approach to

¹ See Butler, Ann. & Mag. Nat. Hist. 1897, xx. p. 464.

this condition may occasionally be seen in the latter species. Many specimens of *P. demoleus* from Aden resemble *P. bennetti* in the narrowness of the pale median band of the hind wing; they differ, however, in the other particulars.

Mr. Bennett's specimens were taken on the extreme summit of Jebel Dryet (4900 ft.), settled on a Bedaween's bright-coloured cotton wrap or loin-cloth. The species is a strong flyer. It was not often met with, and never at a less elevation than 3500 ft. It does not occur in the collection made by Prof. Bayley Balfour.

HESPERIIDÆ.

RHOPALOCAMPTA JUCUNDA Butl. (Nos. 49-51.)

Hesperia jucunda, Butl. Proc. Zool. Soc. 1881, p. 179, pl. xviii. fig. 8.

Three specimens, all ♂. This species, as remarked by Trimen (South Afr. Butt. vol. iii. p. 373) is near *R. keithloa* Wallgr. from the East African mainland. It is also allied to *R. taranis* Hew. (*R. anchises* Gerst.), which has a wide African distribution and occurs at Aden (Butler, *loc. cit.* p. 179).

"Found in the hills, and also in the coast-plain between Ghalansyah and Tamarida."—*E. N. B.*

GEGENES NOSTRADAMUS Fabr. (No. 52.)

One specimen, a ♀. This species, which extends throughout the Mediterranean subregion into the North-western districts of India, was not obtained by Prof. Balfour. Specimens from Aden (var. *karsana* Moore) are more sandy in colour than the Socotran example.

The Heterocera collected by Mr. Bennett consist of 26 specimens, belonging to 16 species. These have been kindly named by Sir George F. Hampson. There are no new forms among them; *Oligostigma incommoda*, which was described by Dr. Butler (Proc. Zool. Soc. 1881, p. 180) from a specimen obtained by Prof. Balfour, does not occur in Mr. Bennett's collection. The Socotran Heterocera, so far as they are known, appear to present a mixture of African and Oriental species, the former predominating, together with some widely-distributed types such as *D. pulchella*. As in the case of the Rhopalocera, the African element does not seem to be exclusively East African. It is unfortunate that the Moths collected by Riebeck¹ were never determined.

COSSIDÆ.

AZYGOPHLEPS INCLUSA Wlk. (No. 53.)

One specimen. Another packed by Mr. Bennett was completely destroyed by beetle larvæ.

"In the hills."—*E. N. B.*

¹ Taschenberg, Zeitschr. f. Naturwiss. Bd. lvi. 1883, p. 182.

ARCTIIDÆ.

DEIOPEIA PULCHELLA Linn. (Nos. 54-57.)

“Ardahan, &c. Always on the grassy slopes of hills. Lived in the grass; never flew more than 2 feet from the ground.”—*E. N. B.*

Four specimens. This species was also obtained by Prof. Balfour.

LITHOSIA VETUSTA Wlk. (No. 58.)

One specimen.

NOCTUIDÆ.

AGROTIS DIVISA Wlk. (Nos. 59, 60.)

Two specimens, one much worn.

EUPLEXIA CONDUCTA Wlk. (No. 61.)

One specimen.

BANIANA INTORTA Swinh. (No. 62.)

One specimen.

CEROCALA VERMICULOSA H.-S. (Nos. 63-69.)

Seven specimens.

CALPE EMARGINATA Fabr. (No. 70.)

One specimen.

GEOMETRIDÆ.

HYPERYTHRA LUCICOLOR Butl. (No. 71.)

One specimen.

BOARMIA ACACIARIA Boisd. (No. 72.)

One specimen.

CRASPEDIA DERASATA Wlk. (No. 73.)

One specimen.

CRASPEDIA LACTARIA Wlk. (No. 74.)

One specimen.

CRASPEDIA PULVEROSARIA Wlk. ? (No. 75.)

One specimen.

PYRALIDÆ.

NEPHOPTERYX sp. (No. 76.)

One specimen, too much worn for recognition.

METASIA sp. (No. 77.)

One specimen.

TORTRICIDÆ.

TERAS sp. (No. 78.)

One specimen.

II. ORTHOPTERA.

By MALCOLM BURR, F.Z.S.

The Orthoptera collected in Socotra by Mr. Bennett are few in number, but not without interest. The new species of *Pæcilocerus* represents a genus found in Northern Africa and in the western part of Asia, and there is a new Cricket, of the genus *Landreva* Walker, with a similar, but wider, distribution. It is probable that these two species are peculiar to the island, as they are not migratory in habits, so far as is known, the Cricket at least being incapable of flight.

There is the usual percentage of cosmopolitan species, but the collection is hardly large enough to give a fair idea of the relation of the island to the neighbouring continents.

A Locustid has been described, *Pachysmopoda abbreviata*¹ (Tasch.), which is not found elsewhere, but was not taken by Mr. Bennett.

FORFICULARIA.

LABIDURA RIPARIA (Pall.).

One male (No. 79).

A cosmopolitan species; originally apparently an inhabitant of the Mediterranean subregion, also occurring in Java, Korea, South America (coll. m.), Burmah, and North America.

BLATTODEA.

PHYLLODROMIA sp.

A very fragmentary example (No. 80), which resembles, but is distinct from, the cosmopolitan *Ph. germanica* (L.).

ACRIDIODEA.

TRYXALIS NASUTA (L.).

One immature specimen (No. 81).

This species occurs in Southern Europe, throughout Africa, India, Burmah, and in Australia.

ACROTYLUS LONGIPES (Charp.).

The solitary example (No. 82) is a variety with the wings rosy at the base, the normal colour being yellow. A blue form has occurred at Zanzibar (*Brunner*). An inhabitant of South-eastern Europe, Asia Minor, Abyssinia, and Zanzibar.

PÆCILOCERUS SOKOTRANUS, sp. n. (Plate XXX. fig. 4.)

Statura minore. Caput conicum, pallidum, vertice inter antennis

¹ *Mecopoda abbreviata*, Taschenberg, Zeitschr. f. Naturwiss. Bd. lvi. 1883, p. 184.

minus producto, horizontale, supra atro, subtus in frontem percurrente, profundius sulcato, fronte reclinata, a latere visa vix sinuata; antennæ breves, nigræ, apicem versus pallidiores, capite et pronoto unitis vix longiores; oculi prominuli. Pronotum cylindricum, fusco-testaceum, carinis nullis instructum, margine postico rotundato, sulco typico paullo pone medium sito; lobi deflexi laterales marginibus, postico sinuato, inferiore recto, antico adscendente, angulis rotundatis. Elytra et alæ perfecte explicata, abdominis apicem vix attingentia, illa angusta, fusco-testacea, unicoloria, densissime reticulata, apice obtuse angulata; hæ elytris breviores, badicæ, apicem versus pallidiores. Femora tibiæque antica et intermedia fusca, tarsi pallidiores; femora postica extus pallida, media macula magna fusca ornata, intus testacea, fusco-reticulata; genibus supra pallidis, lateribus atris; tibiæ posticæ sordide testaceæ, spinis octo albidis, apice nigris, calcaribus terminalibus parvis binis utroque margine supra armatæ. Abdomen fuscum, cylindricum; valvulæ ovipositoris longæ, sinuatæ, pubescentes. ♀.

Dimensions, ♀.

Long. corp.	30 millim.
„ elytrorum	17·5 „
„ pronoti	7·5 „

The two specimens (Nos. 87, 88) from which the description was drawn are somewhat discoloured by spirit, but that is not a very important injury. *P. sokotranus* is considerably smaller than the other species of the genus, and is probably peculiar to the island.

Two females (Nos. 83, 84). Upon the second segment of both specimens there is a curious round pale hard knob, so large that it has caused a space in the elytra where they cover it when at rest. I have omitted it from the description as it seems to be a foreign body, possibly a fungus.

There is also an immature Grasshopper (No. 85), possibly to be referred to the genus *Acridium*.

GRYLLODEA.

LANDREVA, sp. n. ?

A male Cricket (No. 86) of the genus *Landreva* Walk. seems to be new, but is not sufficiently good for description. It is small, testaceous, with truncate elytra and no wings. The tympanum is only visible on the exterior side of the anterior tibiæ (subgenus *Ectolandreva*, Sauss.); the posterior tibiæ are armed with five spines on each margin above, and four terminal spines.

III. INSECTS OF OTHER ORDERS. By several Contributors.

Five species of Odonata, two of Hymenoptera, and one of Diptera were also captured by Mr. Bennett: the first were kindly named by Mr. R. McLachlan, F.R.S., the second by Mr. W. F. Kirby, and the third by Mr. E. E. Austen.

The Odonata were all common species with wide distribution, and it is of interest that they should in this respect contrast so sharply with the Lepidoptera Rhopalocera and Araneidea, and to a less extent with the Orthoptera. The contrast is probably to be explained by the facilities for distribution which the Odonata possess in their powers of flight.

Mr. Bennett records that the Odonata are very numerous on the plains where streams abound.—E. B. POULTON.

Species of Odonata.

PANTALA FLAVESCENS Fabr. (No. 89.)

Mr. Bennett captured one specimen "on banks of streams passing Tamarida."

Mr. McLachlan describes the species as nearly cosmopolitan.

CROCOTHEMIS ERYTHREA Brullé. (No. 90.)

One specimen.

The species occurs in South Europe, all over Africa, Asia, &c. (*R. M.*).

RHYOTHEMIS SEMIHYALINA Dujardin. (Nos. 91, 92.)

Two specimens. "Common near the lagoon at Ghalansyah."—*E. N. B.*

Widely distributed in Africa and occurs in Asia Minor (*R. M.*).

CERIAGRION GLABRUM Burm. (No. 93.)

One specimen.

Nearly all over Africa (*R. M.*). The British Museum contains examples from Socotra, Madagascar, Mauritius, as well as from the mainland of Africa.

Species of Hymenoptera.

BELENOGASTER SAUSSUREI Kirby.

Two specimens (Nos. 94, 95).

This species was described by Mr. W. F. Kirby (P. Z. S. 1881, p. 649) among the insects collected by Prof. Bayley Balfour in Socotra.

HARPACTOPUS sp. inc.

One specimen (No. 96).

A species allied to *H. crudelis*, Smith, but larger, and with reddish mandibles and tibiae. The specimen is, however, in such bad

condition that a description would be useless if not misleading (*W. F. K.*).

Species of Diptera.

SARCOPHAGA, sp. inc.

One specimen (No. 97).

The condition renders it impossible to determine the species (*E. E. A.*).

IV. ARACHNIDA.

By the Rev. O. PICKARD-CAMBRIDGE, M.A., F.R.S., C.M.Z.S.

ARACHNIDA ARANEIDEA.

Fam. EPEIRIDÆ.

Subfam. NEPHILINÆ.

Gen. NEPHILA Leach.

NEPHILA BENNETTI, sp. n. (Plate XXXI. fig. 2.)

Female adult? (No. 98), length $8\frac{1}{2}$ lines.

This Spider is of the ordinary characteristic *Nephila* form, and at the hinder part of the caput are the two characteristic conical tuberculiform eminences, conspicuous in a transverse line; the colour of the caput is dark brown, with two large, somewhat oval, dull yellowish patches at the hinder extremity, each surrounding one of the conical eminences. The thorax is dull, pale yellowish, with black-brown lateral converging stripes, and the whole cephalothorax is thickly covered with light grey pubescence.

Eyes normal.

Legs long, moderately strong; 1, 4, 2, 3, furnished with hairs and slender spines. Femora yellow, slightly tinged with a smoky hue at the anterior extremity; genuæ of the first and second pairs dark brown, those of the third and fourth pairs yellowish; tibiæ, metatarsi, and tarsi deep brown, approaching black. The tibiæ of the fourth pair are furnished throughout their length with numerous coarse black hairs forming a brush; the femora of the first and second pairs have also a similar but not so strong a brush on their fore-half, the hairs on these last shorten in length gradually into the normal hairs of the remaining portion of the joint.

Palpi short, normal; humeral and cubital joints yellowish, radial and digital black-brown, the latter furnished with long coarse bristly hairs.

Falces powerful, normal in form, black-brown.

Maxillæ and *labium* black-brown, the latter with a central longitudinal reddish yellow-brown stripe.

Sternum triangular, slightly longer than broad; deep brown; with

marginal eminences opposite the basal joints of the legs; and the labium is yellowish.

Abdomen cylindrical; the hinder extremity somewhat produced and extending beyond the spinners. The fore extremity is dark brown, succeeded by a strong transverse pale-yellowish or cream-coloured band, the ends of which are produced backwards forming a lateral broken marginal stripe on each side. The upperside between these stripes is of a dull pale hue, closely reticulated with brown in a vermiform pattern, and along the middle is a series of four pairs of roundish pale spots covered with a shining satiny pubescence; the spots in each of these pairs are contiguous or nearly so, and they decrease in size from the foremost to the last pair, which are seated a little way from the posterior extremity of the abdomen. The sides are dark brown, marked with various subparallel undulating yellowish streaks, two largish dark-brown patches on each side being left untouched by them. The underside is deep brown, with a yellowish marginal line in front and on the sides; and beneath the produced portion is a longitudinal, central, silvery-white band stopping short of the spinners. The genital aperture is of great simplicity, consisting of a narrow transverse opening covered by a short, scarcely projecting lip.

This handsome Spider is allied to several other African species, such as *N. femoralis* Luc., *N. sumptuosa* Gerst., and *N. keyserlingi* Blackw., but appears to be abundantly distinct. The only example was not in first-rate condition.

Subfam. GASTERACANTHINÆ.

Gen. GASTERACANTHA Walck.

GASTERACANTHA SODALIS, sp. n. (Plate XXXI. fig. 3.)

Adult female (No. 99), length (not including the posterior abdominal spines) rather over $3\frac{1}{2}$ lines (nearly 8 mm.); breadth of abdomen (including the longest of the lateral spines) $6\frac{3}{4}$ lines (14 mm.).

This Spider is much like *G. madagascariensis* Vins., to which it is nearly allied, but the latter has the transverse abdominal black bars broken off in the middle, and the abdomen itself is wider in proportion from front to back than in the present species; the cephalothorax also and the abdominal markings and spines are of a deeper hue, in fact generally black, whereas in the present Spider they are red-brown. The posterior and fore-lateral spines also are longer and sharper pointed in *G. madagascariensis*, in which also the underside of the abdomen is less thickly blotched with yellow, and the sternum has a strong sub-triangular (or heart-shaped) central, clearly defined, pale yellow spot; while in the present Spider the abdominal blotching is reddish orange-yellow, and the sternum deep brown, with two small indistinct yellowish spots in a transverse line near the middle.

The legs are of a uniform deep brown colour, while in *G. madagascariensis* the coxæ and femora are of a brightish yellow-brown

(in some examples, however, of the latter the legs are of a more uniform dull yellow-brown).

Subfam. TETRAGNATHINÆ.

Gen. TETRAGNATHA Walck.

TETRAGNATHA BOYDI, sp. n. (Plate XXXI. fig. 4.)

Adult female (No. 101), length 4 lines; length of cephalothorax 2 lines; length of falces $2\frac{1}{4}$ lines nearly.

Cephalothorax oblong-oval, truncated at each extremity, and widest near the middle; length double its breadth; lateral marginal impressions at caput very slight; caput and margins of thorax darker than the rest; yellow-brown, but in the dry specimen the colour is unreliable.

Eyes of posterior row equally separated; in a very slightly curved line, the convexity of the curve directed forwards; anterior row much more strongly curved, but with the same direction of the curve; central quadrangle slightly broader than long, and the fore side distinctly shorter than the hinder one; the fore-central pair of eyes longest, and seated on a strongish rounded tubercular prominence; each of the lateral eyes also on a tubercle. The eyes of each lateral pair are much nearer to each other than the fore-central pair are to the hind-centrals. Clypeus rather less in height than half the facial space.

Falces very long and projecting forwards, slightly longer than the cephalothorax; considerably divergent; slightly curved, rather constricted at the fore extremity. Fang more than three-fourths the length of the falx, strong, abruptly bent at the base where it is somewhat enlarged, and there is another somewhat shallow dentiform enlargement towards the middle on the inner side; and each of the falces is armed with a strong, somewhat curved, pointed tooth at its extremity, just below the outer side close to the insertion of the fang; also on the inner side nearly beneath the base of the fang is another strong sharp-pointed tooth; besides these teeth each falx has a double longitudinal row of others along the underside; those on the outside are most numerous (10?) and most equally separated, the inner ones (7 or 8?) strongest and more confined to the posterior portion of the falx, those of both rows diminishing in strength as they run backwards.

Legs very slender; 1, 2, 4, 3, very little difference between 2 and 4; furnished with hairs and a few short slender spines.

Maxilla, labium, and sternum normal.

The *abdomen* was so shrivelled and devoid of colour that nothing can be said as to its colours or markings, which, however, are most probably distinctive of the species.

This Spider is nearly allied to *Tetragnatha taylori* Cambr. (South Africa), but the relative position of the eyes is different, as well as the form of the fang and the denticulation of the falces.

Fam. THOMISIDÆ.

Gen. SELENOPS Dufour.

SELENOPS DIVERSUS, sp. n. (Plate XXXI, fig. 1.)

Adult female (No. 100), length 10 lines.

General form and structure normal.

Cephalothorax considerably broader (at its hinder extremity) than long. Indentation at the junction of caput and thorax large and deep. Colour dark yellowish brown, marked with somewhat irregular pale markings and darker converging lines, and clothed with short grey and other hairs, and with a rather dense marginal row of short, curved, prominent spiniform bristles.

Eyes in normal position. The four centrals of the anterior row form a slightly curved line, the convexity of the curve directed forwards; the two central eyes are rather the smallest of the four, and are further from each other than each is from the lateral eye on its side.

Legs long, strong, furnished with spines and numerous hairs of varying length; a scopula beneath the tarsi, and below the two terminal claws a compact claw-tuft. The colour of the legs is black, marked and, rather irregularly, annulated with reddish yellow-brown; the annuli are clothed with coarsish grey hairs. The legs do not differ much in length, the second pair are the longest, and the first, apparently, slightly shortest.

Falces moderately strong, roundly prominent in front, straight, and of deep blackish red-brown colour.

Maxillæ rather short, oblong, rounded at the extremity, inclined towards the labium; colour dark yellow, pale yellowish at the ends, where they are furnished with fine white hairs.

Labium slightly longer than broad, oblong, rounded at the apex, which is yellowish, the rest deep brown.

Sternum rather longer than broad, short-oval, slightly truncated before, and notched at its hinder extremity. Colour pale dull yellowish brown.

Abdomen flattened, rather longer than broad, nearly quadrate, truncate before, the posterior corners well rounded. Upperside of a dull brownish hue, pretty thickly clothed with short greyish hairs, some of those on the sides disposed in minute groups or tufts giving it a spotty appearance; along the middle is a rather diffuse but symmetrical black pattern, formed by a central longitudinal stripe, emitting various spots and markings on each side, and ending in a transverse angulated, black, irregular bar near the hinder extremity: the surface of the abdomen from this bar to just above the spinners is distinctly paler than the rest; sides deep brownish, and underside like the upper in colour. Genital aperture small, but of distinctive form. Spinners short, of about equal length, compact, and similar in colour to the underside.

This Spider is allied to *S. dufourii* Vins., and also to *S. madagascariensis* Vins., but may be easily distinguished from the latter



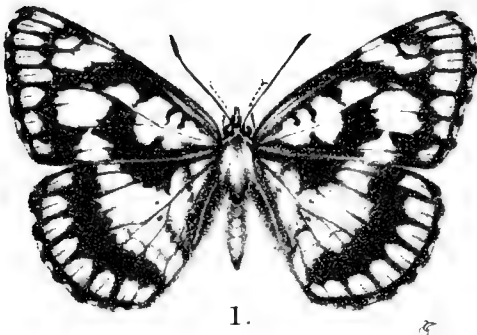

1.

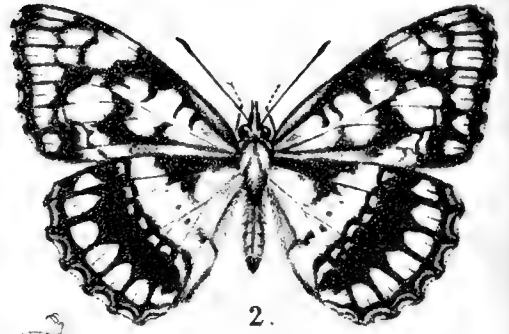

2.

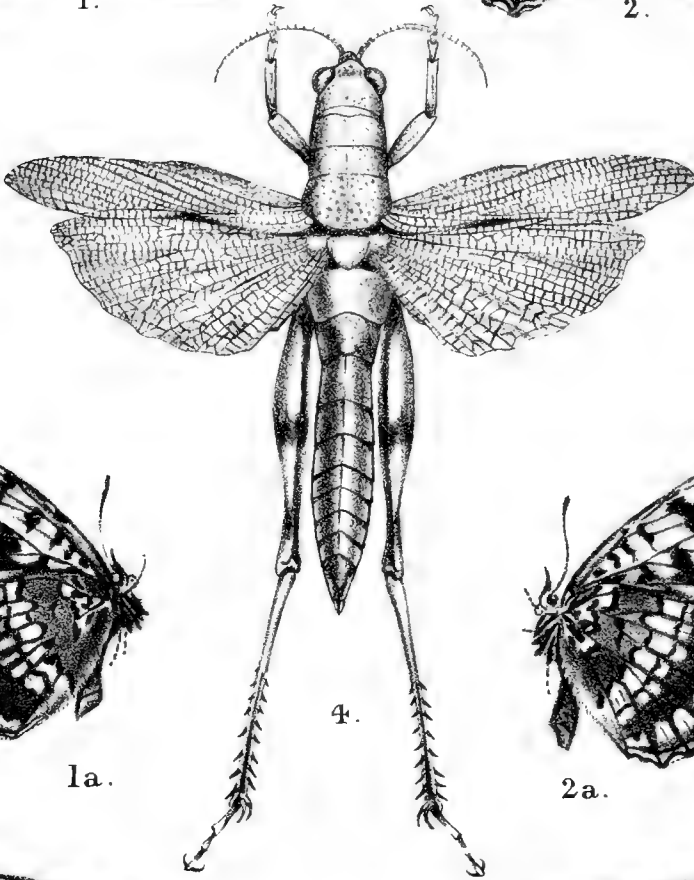

4.

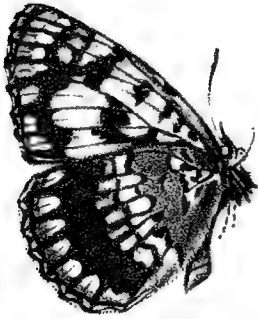

1a.



2a.

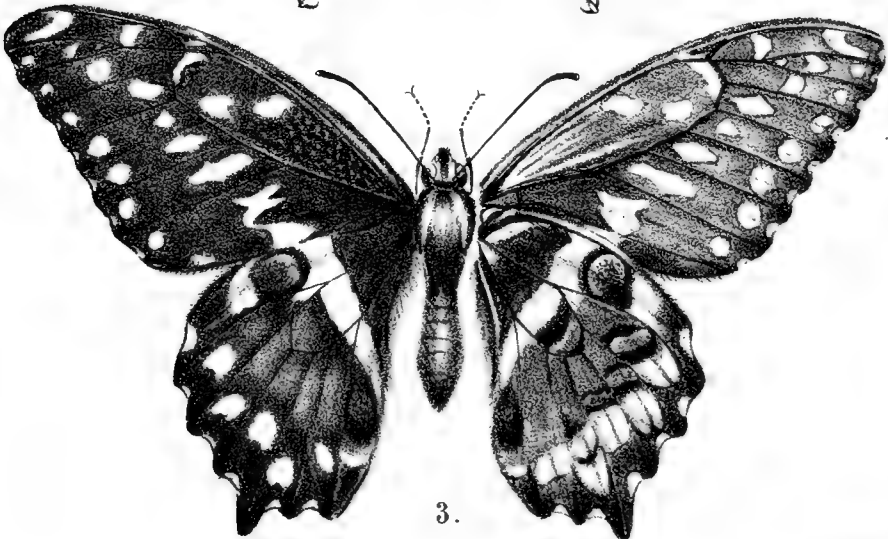

3.



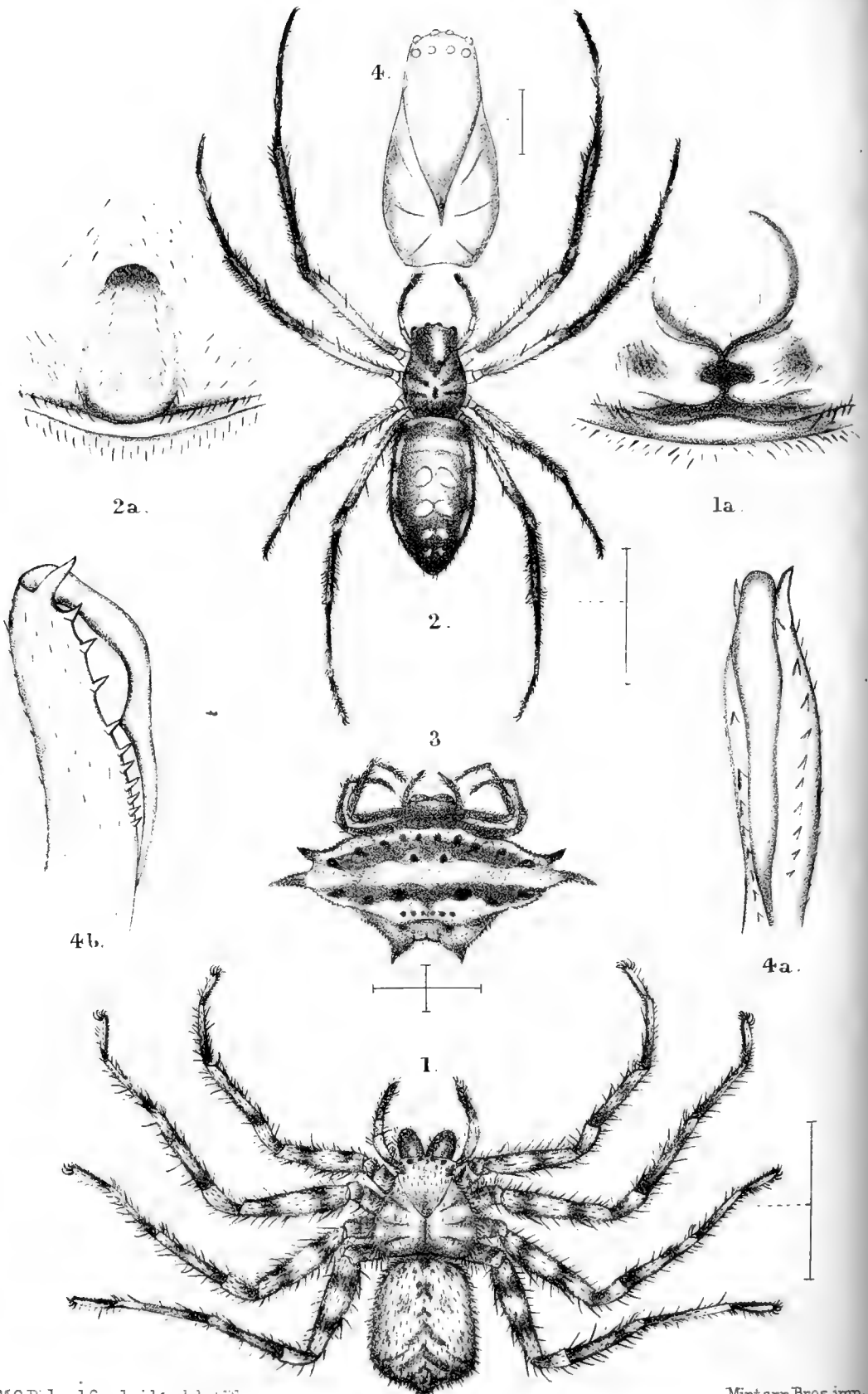

by the pattern on the abdomen, of which the form also is different. In *S. dufourii* the pale posterior extremity shows on its posterior border five distinct pale points; the present species shows only three, and those somewhat irregularly defined. The present Spider is also of much larger size than either of those mentioned, the length given of *S. dufourii* being 12 millim., and that of *S. madagascariensis* 11 millim., whereas *Selenops diversus* measures in length 10 lines, or nearly as possible 21 millim.

EXPLANATION OF THE PLATES.

PLATE XXX.

- Fig. 1. *Byblia boydi*, sp. n., ♂, p. 375.
 1a. " " " ♂, underside.
 2. " " " ♀.
 2a. " " " ♀, underside.
 3. *Papilio bennetti*, sp. n., ♂, p. 381.
 4. *Pæcilocerus sokotranus*, sp. nov., ♂ p. 384.

PLATE XXXI.

- Fig. 1. *Selenops diversus*, sp. n., ♀, p. 390.
 1a. " " " Genital apertures.
 2. *Nephila bennetti*, sp. n., ♀, p. 387.
 2a. " " " Genital apertures.
 3. *Gasteracantha sodalis*, sp. n., ♀, p. 388.
 4. *Tetragnatha boydi*, sp. n., p. 389. Cephalothorax and eyes.
 4a & 4b. " " " Falx and fang in two positions.

May 17, 1898.

W. T. BLANFORD, Esq., F.R.S., V.P., in the Chair.

The following papers were read:—

1. On a small Collection of Mammals obtained by Mr. Alfred Sharpe, C.B., in Nyasaland. By OLDFIELD THOMAS, F.Z.S.

[Received April 23, 1898.]

Now that Sir Harry Johnston has left Nyasaland, the efforts he made to investigate the fauna of that country are fortunately being continued by his successor in the post of Commissioner and Consul-General, Mr. Alfred Sharpe, C.B., to whom the British Museum is already indebted for a certain number of specimens. These, among which the most noticeable is the little Antelope described as *Raphiceros sharpei*, have already been mentioned in previous papers.

In October 1897 Mr. Sharpe made a trip to the northern

boundaries of Nyasaland, and there obtained a small collection of mammals, some from the Songwe River, and some brought in by native collectors from still further northward. The present paper gives a list of these specimens and also includes a few additional mammals from Zomba and other places in Southern Nyasa, among which are two Genets presented by Mr. H. C. McDonald. The paper thus forms another, the sixth, of the series read before this Society upon the Mammals of Nyasaland.

1. *RHYNCHOCYON CIRNEI* Peters.

a, b. Zomba, 8 and 11/97.

2. *VIVERRA CIVETTA* Schr.

a. Immature.

3. *GENETTA TIGRINA* Schr.

a. Kazungu; *b.* Kotakota, 30/9/97.

Collected and presented by H. C. McDonald, Esq.
Native name "Mwiri."

4. *CROSSARCHUS FASCIATUS* Desm.

a. Zomba, 10/11/97.
Mananga name "Sulu."

5. *LUTRA CAPENSIS* Schinz.

a. Imm. ♂. Ntondwe River, Shiré Highlands, 3000 feet,
June 1897.

This fine Otter is still very rare in collections, and further specimens of it, especially adult skulls of either sex, would be most acceptable. Skulls alone, to any number, would always be worth preserving.

6. *LUTRA MACULICOLLIS* Licht.

a. Young. Zomba Plain, 2500 feet.

7. *SCIURUS MUTABILIS* Pet.

a, b. Chiradzula, June 1897.

c. Zomba, June 1897.

Native name "Nabenga."

8. *GERBILLUS AFER* Gr.

a, b. Ad. and imm. ♂. Songwe, Oct. 1897.

9. *GERBILLUS (GERBILLISCUS) FRATERCULUS*, sp. n.

a. ♂. Songwe, 2500 feet, Oct. 1897. *Type.*

Considerably smaller than the only previously known species of the subgenus, *G. böhmi* Noack. General colour similar, but more heavily marked with black on the back, the black-tipped hairs

being specially numerous over the loins. Belly-hairs slaty grey basally. Hands and feet pure white above, the latter conspicuously shorter than in *G. böhmi*. Tail long, brown above throughout, white below, not white all round terminally as in *G. böhmi*.

Skull smaller and slighter than in *G. böhmi*. Interparietal larger. Palatal foramina narrow and laterally compressed. Posterior narial passage narrow, its opening above reduced to a mere notch in the centre.

Teeth. Incisors quite smooth and rounded in front, without even the rudimentary grooves found in *G. böhmi*. Molars comparatively light and delicate.

Dimensions of the type, an adult female, in skin:—

Head and body 120 mm.; tail 122; hind foot (moistened) 32; ear 17.

Skull: basilar length 29 mm.; nasals 14.2×4.1 ; interorbital breadth 6; breadth of brain-case 15; length of anterior zygoma-root 7.5; diastema 10.1; palate length from henselion 17.5; upper molar series (crowns) 5.8.

Hab. Songwe, N. Nyasa.

Type. B.M. No. 98.5.22.14. Collected and presented by Mr. Alfred Sharpe.

This species may be readily distinguished by its smaller size and differently-coloured tail from *G. böhmi*, of which the British Museum recently received examples obtained at Fort Hill during Mr. Whyte's exploration of Northern Nyasa¹.

10. *STEATOMYS PRATENSIS* Pet.

a-d. Songwe, Oct. 1897.

11. *EQUUS BURCHELLI CRAWSHAYI* De Wint.

a, b. Adult and young. Zomba.

12. *BUBALIS LICHTENSTEINI* Pet.

a, b. ♀. Zomba.

13. *CEPHALOPHUS LUGENS*, sp. n.

a, b. Imm. ♀ and its foetus. Urori.

c. Flat skin. October 1897.

A member of the *C. monticola* group, but larger and darker coloured than in any of the three species of that group, *C. monticola*, *melanorheus*, and *aequatorialis*². Female with horns.

General colour above dark umber-brown. Forehead and top of muzzle nearly black, the crest, which is much longer than is usual in this group, quite black; sides of face brown, the lines over the eyes brownish white. Backs of ears black for their anterior halves.

¹ See P. Z. S. 1897, p. 935.

² Since the above was written Dr. Matschie has described (S.B. Ges. nat. Fr. 1897, p. 158) another member of this group—*C. hecki*, from Mozambique; but that, like *C. monticola*, has red legs.

Neck uniformly brown, like the back; the hairs on its middle line above reversed forward. Colour of back gradually darkening posteriorly almost or quite to black, but this darker colour is not shown up by a lighter patch on the outer side of each hip, as it is in *C. melanorheus* and *aquatorialis*, but, as in *C. monticola*, the hips are uniformly brown. Under surface and inner side of forearms pale mouse-colour, the chin, interramia, and inguinal region whitish. Limbs dark brown like back, not reddish as in *C. monticola*.

Skull slightly larger than in *C. monticola*, though the type is immature. Horns (of ♀) well developed, about an inch in length. Median notch of palate scarcely anterior to lateral notches.

Skull-dimensions of the type, a female, which, though its milk-dentition is still in place, contained a foetus when killed:—

Extreme length 131 mm.; basal length 114; greatest breadth 62.5; nasals 37 × 20; breadth of brain-case 49; palate length 68.

Hab. Urori (also called Usango), German East Africa, about 8° S. and 34° E. Altitude about 3000 feet.

Type. B.M. No. 98.5.22.21. Killed October, 1897.

The foetus, specimen *b*, extracted from the type by the skinner, is similar to its mother in colour, except that the general tone of the body is not so dark, owing to an admixture of rufous hairs on the back; the hairs on the inner sides of the ears are also rufous. But the blackish frontal colour, the dark brownish limbs, and the absence of the lighter patches on the back of the hips are all as evident in the foetus as in its parent.

The specimens of this new species were brought to Mr. Sharpe by his native hunters, who obtained it in Urori, some way north-east of the German frontier of British Nyasaland.

Cephalophus lugens is very probably the little Antelope referred to by Matschie¹ as having been seen by Böhmer near Mpwapwa, where it was known under the name of "Nsimba."

14. NESOTRAGUS LIVINGSTONIANUS Kirk.

a. Ad. ♀. Mwanza, Lower Shiré, 2500 feet, July 1897.

Native name "Kadumba." Contained a foetus when killed.

This little Antelope forms a valuable addition to the Museum collection, as it is practically a topotype of Kirk's species, of which the actual type only consists of a very incomplete skull and the skin of the head. That specimen came from Shupanga, a little below the junction of the Shiré with the Zambesi.

15. KOBUS VARDONI Livingst.

a. ♀. Urori (Usango), 3000 feet, October 1897.

16. OREAS CANNA LIVINGSTONEI Sel.

a. Skin ♀. Zomba.

b. Skull ♂. „

¹ Säug. Deutsch-Ost-Afr. p. 115 (1895).

2. On a Collection of Lepidoptera made in British East Africa by Mr. C. S. Betton. By ARTHUR G. BUTLER, Ph.D., F.L.S., F.Z.S., &c., Senior Assistant-Keeper, Zoological Department, British Museum.

[Received April 21, 1898.]

(Plates XXXII. & XXXIII.)

Mr. Betton's collection is a singularly interesting one, rich in rare and new species, three Butterflies and twenty-six Moths from the present series being now described for the first time. Among the Butterflies also I may call attention to a suite of *Acræa chilo*, females of *A. crystallina*, the wet-season forms of both *Teracolus hetera* and *T. puniceus*, the dry form of *T. leo*, a number of examples of *T. venata*, and an example of the rare *Alena picata*, a species new to the Museum collection.

Although Mr. Betton desired to retain a collection for his private use, yet he sanctioned the whole of the types of new species, and examples of all species needed to perfect the National collection, being retained. Among the Heterocerous Lepidoptera, many of which were only represented by single specimens, he has thus suffered somewhat severely in the interests of science; but in the Butterflies there was considerably less required in proportion to the numbers collected.

Mr. Betton's line of march extended from Mombasa in a north-westerly direction by way of Samburu, Taru, Voi, and Ndi to Tsavo¹. He has furnished the following notes on the weather prevailing at certain dates between March 1896 and August 1897, during which time his collection was made:—

1896.

March 1st–20th. Slight rain.

May 1st, "greater" rains commence; May 11th–13th, heavy and continuous rain; May 13th to end of month, slight rain.

June 21st–27th. Slight rain.

October 24th. Rains ("lesser") commence.

November 1st–15th. Heavy and continuous rains: rain nearly every day to end of month.

December. Showers nearly all the month.

1897.

February 18th–20th. Storms.

March 3rd, 4th, and 18th. Storms.

April 3rd and 4th. Storms.

April 14th–22nd. Slight rains.

May 16th–23rd. Slight rains.

July 8th and 9th. Heavy showers.

August 10th to 22nd. Slight rains occasionally.

¹ See for map the Parliamentary Report on the Mombasa-Victoria Railway, 1898—Africa no. 8.

In working out some of the more obscure Moths, Sir George Hampson has kindly assisted me, both by the loan of pamphlets and by personal examination of structural characters.

The following is a list of the species obtained:—

I. RHOPALOCERA.

NYMPHALIDÆ.

1. AMAURIS DOMINICANUS.

Amauris dominicanus, Trimen, Trans. Ent. Soc. 1879, p. 323.

Mgana, 4th July, 13th and 30th August, 1896; Mombasa, January 1897.

2. AMAURIS OCHLEA.

Euploea ochlea, Boisduval, App. Voy. de Deleg. dans l'Afr. Austr. p. 589 (1847).

Mombasa, 26th April, 1896.

Rather an unusually large female.

3. LIMNAS CHRYSIPPUS, var. KLUGI.

Limnas klugii, Butler, P. Z. S. 1885, p. 758.

♀, Samburu, British E. Africa, 15th November; ♂ ♀, Taru, Taru Desert, 13th, 16th, 18th, and 20th December, 1896; ♂, Voi, 1st May, 1897.

The specimen from Voi is about one-third larger than any of the others, and one of the specimens obtained on the 20th December is a transitional form towards var. *dorippus*, Klug.

4. MYCALESIS SAFITZA.

Mycalesis safitza, Hewitson, Gen. Diurn. Lep. p. 394, pl. 66. fig. 3 (1851).

♂ ♂, Chanjamwe, 28th July; ♂ ♂ ♀, Mgana, 28th August; ♂ ♀, Taru, 16th and 20th December, 1896; ♀, Mombasa, 7th January, 1897.

4 a. MYCALESIS EVENUS.

Mycalesis evenus, Hopffer, Monatsber. königl. Akad. Wiss. Berl. 1855, p. 641; Peters's Reise n. Mossamb. p. 394, pl. 25. figs. 5, 6 (1862).

Wet form. Mgana, 12th July, 1896.

Dry form (= *caffra*, Wallgr.). Taru, 19th December, 1896.

Mr. Trimen regards this as a variation of the preceding species, and I think it probable that he is right.

5. SAMANTA PERSPICUA.

Mycalesis perspicua, Trimen, Trans. Ent. Soc. Lond. 1873, p. 104, pl. 1. fig. 3 (♂).

♂ ♀, Chanjamwe, 28th July; ♂, Mgana, 28th August, 1896.

6. *PHYSCÆNURA LEDA*.

Periphyssia leda, Gerstaecker, in Von der Decken's Reisen in Ost-Afrika, iii. 2, p. 371, pl. xv. figs. 3, 3a (1873).

Mgana, 6th, 13th, and 28th August, 1896; Maungu Inkubwa, 21st March, 1897.

7. *MELANITIS SOLANDRA*.

Papilio solandra, Fabricius, Syst. Ent. p. 500 (1775).

Dry-season ♀, Mgana, 6th August, 1896.

8. *CHARAXES NEANTHES*.

Nymphalis neanthes, Hewitson, Exot. Butt. i. p. 88, pl. 44. figs. 2, 3 (1854).

♀, Maungu Inkubwa, 21st March, 1897.

9. *CHARAXES ZOLINA*.

♀. *Nymphalis zolina*, Westwood and Hewitson, Gen. Diurn. Lep. pl. liii. fig. 1 (1850).

♂♂, Taru, 13th December, 1896; Maungu Inkubwa, 21st March, 1897.

10. *CHARAXES CITHÆRON*.

Charaxes cithæron, Felder, Wien. ent. Monatschr. iii. p. 398, pl. 8. figs. 2, 3 (1859).

♂♂, Maungu Inkubwa, 21st March, 1897.

11. *CHARAXES VARANES*.

Papilio varanes, Cramer, Pap. Exot. ii. pl. clx. D, E (1779).

♂♂, Maungu Inkubwa, 21st March, 1897.

12. *JUNONIA LIMNORIA*, var. *TAVETA*.

Precis taveta, Rogenhofer, Ann. Hof-Museum, Wien, vi. p. 460, pl. xv. fig. 7 (1891).

♂, Maungu Inkubwa, 21st March, 1897; ♀, Taru, 11th December, 1896.

A perfect pair of this species, of which we previously had a poor series.

13. *JUNONIA GURUANA*.

Precis guruana, Rogenhofer, Verh. zool.-bot. Gesellsch. Wien, xli. p. 564 (1891).

♂♀, Maungu Inkubwa, 21st March, 1897.

A nearly perfect pair of this rare butterfly. Looking at the variability of the allied *J. pelasgis*, it seems possible that this may be an extreme form of the preceding species.

14. *JUNONIA AUBORINA*.

Junonia auroarina, Butler, P. Z. S. 1893, p. 651, pl. lx. fig. 3.

♂♂♀♀, Maungu Inkubwa, 21st March, 1897.

One very shattered male nearly approaches *J. pyriformis* in colouring, and shows the intensely dry character of that insect on the under surface. It will be remembered that in 1896 (P. Z. S. p. 111) I suggested the possibility of the latter being a form of *J. aurorina*. As the fact that the latter and *J. tugela* fly together in the wet-season in S. Africa seems to disprove the statement that they are seasonal forms of one species, it would appear more probable that *J. pyriformis* is the dry form of *J. aurorina*, the single example of the former in this collection having evidently been a considerable time on the wing; however, we need more evidence before deciding this point, especially as all three of these species have dry-season undersides to the wings.

15. JUNONIA CUAMA.

Junonia cuama, Hewitson, Exot. Butt. iii., *Jun.* pl. i. figs. 4, 5 (1864).

♀, Maungu Inkubwa, 21st March, 1897.

16. JUNONIA CEBRENE.

Junonia cebrene, Trimen, Trans. Ent. Soc. Lond. 1870, p. 353.

♂, Samburu, 19th November; ♀ ♀, Taru, 16th December, 1896;
♂ ♀, Maungu Inkubwa, 21st March, 1897.

17. JUNONIA CLELIA.

Papilio clelia, Cramer, Pap. Exot. i. pl. xxi. E, F (1775).

♂, Mombasa, 4th January, 1897.

18. JUNONIA NATALICA.

Precis natalica, Felder, Wien. ent. Monatschr. iv. p. 106 (1860).

Taru, 16th December, 1896.

19. PROTOGONIOMORPHA NEBULOSA.

Salamis nebulosa, Trimen, Trans. Ent. Soc. Lond. 1881, p. 441.

♂ ♀, Mgana, B. E. Africa, 13th and 28th August, 1896.

This is the Eastern form of *P. aglatonice*, from which the male differs very little, the apical black area of the primaries being only slightly broader. I take *P. aglatonice* to be the Western type, the female of which more nearly resembles the male. A third form differing to about the same extent is *P. definita* of Madagascar, which I formerly confounded with males of *P. nebulosa*.

20. PYRAMEIS CARDUI.

Papilio cardui, Linnæus, Faun. Suec, p. 276 (1761).

Mgana, 2nd September, 1896.

21. HYPOLIMNAS MISIPPUS.

Papilio misippus, Linnæus, Mus. Lud. Ulr. p. 264 (1764).

♂ ♂, Taru, 16th and 20th December, 1896; Mombasa, January 4th; ♂ ♀ ♀, Maungu Inkubwa, March 21st, 1897.

22. EURALIA KIRBYI.

Euralia kirbyi, Butler, P. Z. S. 1898, p. 51.

Mgana, 11th August, 1896 (one damaged male).

The sudden appearance in recent collections of this fine species is curious; last year we received two specimens in Mr. Kirby's collection and two from Sir H. Johnston, obtained at Zomba.

23. EUXANTHE WAKEFIELDII.

Godartia wakefieldii, Ward, Ent. Month. Mag. x. p. 152 (1873); Afr. Lep. pl. 6. fig. 3 (1874).

♂ ♀, Mgana, 2nd and 11th August, 1896.

24. HAMANUMIDA DÆDALUS.

Papilio dædalus, Fabricius, Syst. Ent. p. 482 (1775).

Dry form. ♂, Samburu, 26th October, 1896.

Wet form. ♂ ♂ ♀ ♀, Taru, 18th and 19th December, 1896, 17th January, 1897.

25. EUPHLEDRA VIOLACEA.

Eurypheue violacea, Butler, P. Z. S. 1888, p. 91.

♂ ♂, Mombasa, 4th January, and Voi, 1st May, 1897.

Two tolerably good examples of this beautiful species.

26. LACHNOPTERA AYRESII.

Lachnoptera ayresii, Trimen, Trans. Ent. Soc. Lond. 1879, p. 326; South Afr. Butt. i. pl. iii. figs. 5, 5 a (1887).

♀, Maungu Inkubwa, 21st March, 1897.

One very worn example only was obtained.

27. ATELLA COLUMBINA.

Papilio columbina, Cramer, Pap. Exot. iii. pl. cccxxxviii. A, B, iv. pl. cccxxxvii. D, E (1782).

Chanjamwe, 31st May, 1896; Mombasa, 7th January, 1897.

28. NEPTIS AGATHA.

Papilio agatha, Cramer, Pap. Exot. iv. pl. cccxxvii. A, B (1782).

Mombasa, 7th January, 1897.

29. NEPTIS MARPESSA.

Neptis marpeassa, Hopffer, Monatsb. königl. Akad. Wiss. Berl. 1855, p. 640; Peters's Reise n. Mossamb., Ins. p. 383, pl. xxiv. figs. 9, 10 (1892).

Maungu Inkubwa, 21st March, 1897.

30. EURYTELA FULGURATA.

Libythea fulgurata, Boisduval, Faun. Madag. p. 52, pl. 8. fig. 5 (1833).

Mgana, 19th July, 1896.

Only one shattered example was obtained; it does not differ from Malagasy specimens.

31. EURYTELA DRYOPE.

Papilio dryope, Cramer, Pap. Exot. i. pl. lxxviii. E, F (1779).
Mombasa, 7th January, 1897.

32. BYBLIA ILITHYIA.

Papilio ilithyia, Drury, Ill. Exot. Ent. ii. pl. 17. figs. 1, 2 (1773).
♂, Mgana, June 22nd; ♂ ♀, Taru, December 13th and 18th,
1896; ♂, Voi, May 2nd, 1897.

The whole of the specimens belong to the typical "wet-season" phase: it must be a long wet season to last from the middle of December to near the end of June!

33. PLANEMA MONTANA.

Planema montana, Butler, P. Z. S. 1888, p. 91.
Acræa berthæ, Vuillot, Novit. Lep. xii. pl. xix. fig. 5 (1895).
Maungu Inkubwa, 21st March, 1897.
One good male of this rare species.

34. ACRÆA METAPROTEA, var. JACKSONI.

♀. *Planema jacksoni*, E. M. Sharpe, Ann. & Mag. Nat. Hist. ser. 6, vol. v. p. 335; Waterhouse, Aid Ident. Ins. pl. clxxxix. fig. 1 (1890).

♂, Maungu Inkubwa, 21st March, 1897.

In males of this Eastern variety the subapical band of primaries is separated by a long interval from the internal patch, as in the Western varieties of the species.

35. ACRÆA SERENA, var. PERRUPTA.

Telchinia perrupta, Butler, Ann. & Mag. Nat. Hist. ser. 5, vol. xii. p. 102 (1883).

♂ ♀, Mombasa, 4th and 7th January, 1897.

This variation is barely separable from *A. serena*, var. *buxtoni*; but the male of the latter is usually more brightly coloured, with blacker borders and the black lunate patch closing the cell of the primaries never tending to join the outer borders by means of an intermediate spot: the females of both are extremely variable.

36. ACRÆA LYCIA and vars.

Papilio lycia, Fabricius, Syst. Ent. p. 464 (1775).
Voi, April 15th and May 1st, 1897.

Var. *SGANZINI*, Boisduval.

Voi, April 15th and May 2nd, 1897.

Var. *DAIRA*, Godman.

Voi, April 15th and May 1st and 2nd, 1897.

Not only is there one perfectly intermediate specimen between the variety *A. sganzini* and typical *A. lycia*, but a male of the variety *A. sganzini* was taken on May 2nd *in copulâ* with the variety *A. दौरा*.

37. *ACRÆA CÆCILIA*, var. *STENOBEA*.

Acræa stenobea, Wallengren, Wien. ent. Monatschr. iv. p. 35 (1860).

♀, Taru, 18th December, 1896.

This specimen much interests me; it is the first example of this variety which I have seen from Eastern Africa, has the colouring of the male, but with all the black spots of typical *A. cæcilia*; it thus fully confirms the correctness of my decision in sinking *A. stenobea* as a mere variety (or, possibly, seasonal form) of *A. cæcilia*.

38. *ACRÆA NATALICA*.

Acræa natalica, Boisduval, App. Voy. de Deleg. p. 590 (1847).

♂ ♀, Mayera, 20th July; ♀, Mgana, 26th July, 1896.

39. *ACRÆA BRÆSIA*.

Acræa bræsia, Godman, P. Z. S. 1885, p. 538.

Voi, 1st and 2nd May, 1897.

40. *ACRÆA CHILO*.

Acræa chilo, Godman & Salvin, P. Z. S. 1880, p. 184, pl. xix. figs. 4, 5.

♂, Maziwa-Mitatu, 24th March; Voi, 1st and 2nd May, 1897.

One of the characteristics of typical *A. chilo* is the strongly concave outer margin to its primaries, but in Mr. Betton's series every gradation exists to a distinctly convex outer margin.

41. *ACRÆA ANEMOSA*.

Acræa anemosa, Hewitson, Exot. Butt. iii. pl. 8. figs. 14, 15 (1865).

♀, Samburu, 15th November, 1896; ♂, Voi, 1st May, 1897.

42. *ACRÆA NEOBULE*.

Acræa neobule, Doubleday & Hewitson, Gen. Diurn. Lep. pl. xix. fig. 3 (1848).

♀, Maungu Inkubwa, 21st March; ♂, Ndara Hills, 6th April, 1897.

43. *ACRÆA CRYSTALLINA*.

♂. *Acræa crystallina*, H. Grose-Smith, Ann. & Mag. Nat. Hist. ser. 6, vol. v. p. 167 (1890); Rhop. Exot. i., *Acræa*, pl. iii. figs. 3, 4 (1892).

♀ ♀, Voi, 1st and 2nd May, 1897.

This species is entirely new to the Museum collection.

44. *PARDOPSIS PUNCTATISSIMA*.

Acræa punctatissima, Boisduval, Faune Ent. Madag. p. 31, pl. 6. fig. 2 (1833).

Mgana, 30th August, 1896.

LYCÆNIDÆ.

45. *ALCENA PICATA*.

Alcena picata, E. M. Sharpe, Ann. & Mag. Nat. Hist. ser. 6, vol. xvii. p. 126 (1896).

♂, Voi?, B. E. Africa¹.

No exact habitat accompanied the single example of this rare species; it is quite new to the Museum collection.

46. *PARAPONTIA SUBPUNCTATA*.

Teriomima subpunctata, Kirby, Ann. & Mag. Nat. Hist. ser. 5, vol. xix. p. 364 (1887); Grose-Smith & Kirby, Rhop. Exot. i., *Afric. Lyc.* pl. iii. figs. 11, 12 (1888).

♂♂, Taru, 16th December, 1896.

Only two males of this rare species were obtained; it is quite new to the Museum collection. It is now evident that this is an Eastern (not Western) species, and an examination of its neuration and other structural characters, as well as a comparison of the markings of the under surface, make it evident that it is nearly related to *Parapontia undularis*. Mr. Betton's specimens are slightly larger and more distinctly washed with buff on the costal and apical areas of the primaries and the secondaries upon the under surface than in the type.

47. *TINGREA AMENAIIDA*.

Pentila amenaida, Hewitson, Exot. Butt. v., *Pent. & Lipt.* pl. 2. figs. 4-7 (1873).

Mgana, 13th August; Taru, 13th, 18th, and 19th December, 1896.

This species is exceedingly variable on both surfaces; the black border of the primaries above is sometimes reduced to an apical patch, that of the secondaries being reduced to a row of spots or wholly absent, whilst on the under surface the submarginal row of spots is either faintly indicated or entirely wanting. If only single examples of the extreme types were received, they would be unhesitatingly described as distinct species: I have no doubt that *T. nero* and *T. berthia* are varieties, for we have exactly similar specimens, but with smaller spots, whilst the size of the spots is unquestionably extremely variable.

48. *DURBANIA HILDEGARDA*.

Teriomima? hildegarda, Kirby, Ann. & Mag. Nat. Hist. ser. 5, vol. xix. p. 357 (1887); Grose-Smith & Kirby, Rhop. Exot. i., *Afric. Lyc.* pl. iv. figs. 7, 8 (1888).

Var. *Teriomima freya*, Grose-Smith & Kirby, Rhop. Exot. ii., *Afric. Lyc.* pl. xxv. figs. 1, 2 (1894).

Mgana, 27th June and 13th July; Samburu, 10th November;

¹ It was amongst a number of Lepidoptera obtained at Voi; it therefore probably came from that locality.

Taru, 16th, 19th, and 20th December, 1896; Mombasa, 7th January, 1897.

The variation of the markings of the upper surface in this species is considerable and may be thus described:—

1.—*Primaries*. Costal markings not entering the discoidal cell, but forming a K-shaped marking immediately beyond cell; outer border wide on costa, rapidly tapering and becoming linear after second median branch, not reaching external angle.

Secondaries. Outer border extremely narrow. Mgana.

2.—*Primaries*. Costal markings extending quite across discoidal cell and completely confluent with outer border, which tapers gradually to external angle and extends a short distance along the inner margin. In this variety the outer border occupies about a third of the wing.

Secondaries. Outer border broad in the centre, squamose at both extremities. One shattered and worn starved example. Mgana.

3.—*Primaries*. Costal markings extending across discoidal cell, but separated from outer border, which is slightly narrower than in var. 1, but continued to inner margin.

Secondaries. With tolerably broad outer border of nearly uniform width (typical *D. hildegarda*). Samburu.

4.—*Primaries*. Costal markings as in var. 1, but outer border continued to inner margin.

Secondaries. Outer border distinctly narrower than in var. 3, and especially towards anal angle. Taru.

5.—Like var. 3, excepting that the outer borders of all the wings are broader (typical *D. freya*). Taru.

It is difficult to find two specimens which exactly agree in pattern.

49. POLYOMMATUS BÆTICUS.

Papilio bœticus, Linnæus, Syst. Nat. i. 2, p. 789 (1767).

♂, Taru, 18th December, 1896.

50. CATOCHRYSOPS OSIRIS.

Lycæna osiris, Hopffer, Ber. Verh. Ak. Berlin, 1855, p. 642; Peters's Reise n. Mossamb. v. p. 409, pl. 26. figs. 11, 12 (1862).

♀, Mgana, 30th August, 1896; ♂, Maungu Inkubwa, 21st March, 1897.

Only one unusually large pair was obtained.

51. CATOCHRYSOPS PERPULCHRA.

Lycæna perpulchra, Holland, Entomologist, 1892, Suppl. p. 90; Proc. U.S. Nat. Mus. vol. xviii. p. 239, pl. vii. fig. 7 (1895).

♀, Mombasa, 7th January, 1897.

This is an unusually white example; we possess a similar, though more worn, example from Zomba. My original type of *C. hypo-leucus* from the Victoria Nyanza appears to be a distinct species; it is considerably larger, the under surface tinted with buff, all

the black spots larger: two additional spots to the discal series of primaries, the lower half of the submarginal stripe of primaries blackish, and that of the secondaries commencing with two short black bars placed angle to angle; a few black scales are also sprinkled on the other divisions of this stripe.

52. CATOCHRYSOPS HIPPOCRATES.

Papilio hippocrates, Fabricius, Ent. Syst. iii. p. 288 (1793).

♀, Mgana, 13th August, 1896.

53. CUPIDOPSIS JOBATES.

Lycæna jobates, Hopffer, Ber. Verh. Ak. Berlin, 1855, p. 642; Peters's Reise n. Mossamb. v. p. 408, pl. 26. figs. 9, 10 (1862).

Mgana, 30th August, 1896; Mombasa, 4th January, 1897.

54. AZANUS JESOUS.

Polyommatus jesous, Guérin, Lefebvre's Voy. Abyss. vi. p. 383, pl. 11. figs. 3, 4 (1847).

♀, Mgana, 28th June, 1896; ♂♂, Voi, 1st May, 1897.

55. TARUCUS PLINIUS.

Hesperia plinius, Fabricius, Ent. Syst. iii. 1, p. 284 (1793).

♀♀, Taru, 22nd November and 20th December, 1896.

56. NACADUBA SICHELA.

Lycæna sichela, Wallengren, Kongl. Svenska Vetens.-Akad. Handl. 1857; Lep. Rhop. Caffr. p. 37.

♂, Voi, 1st May, 1897.

57. ZIZERA GAIKA.

Lycæna gaika, Trimen, Trans. Ent. Soc. Lond. ser. 3, vol. i. p. 403 (1862).

Mgana, 13th August and "20th December (N. P. D.)," 1896. N. P. D. are probably the initials of the captor, as Mr. Betton, at the time, was at Taru.

58. CASTALIUS MELÆNA, var.

Lycæna melæna, Trimen, South-Afr. Butt. ii. p. 82.

Voi, 1st May, 1897.

An extraordinary specimen of what I take to be a very melanistic form of this species, in which the spots on the primaries above are greatly reduced in size and the white area of the secondaries is only represented by an irregular central band: on the under surface the markings are slightly thicker and blacker, but otherwise are identical with those in South-African specimens. We are so badly off for this species that it is possible that similar varieties of the species may occur also in Natal. Until I compared the under-surface pattern in the two insects, I imagined that they would prove to be quite distinct.

59. *LYCÆNA KERSTENI*.

Lycæna kersteni, Gerstaecker, in Von der Decken's Reisen in Ost-Afrika, iii. 2, p. 373, pl. xv. fig. 5 (1873).

♂ ♂, Taru, 20th December, 1896; Voi, 1st May, 1897.

This is the Eastern representative of *L. larydas*; it has much more white on the under surface.

60. *LYCENESTHES SYLVANUS*.

Papilio sylvanus, Drury, Ill. Exot. Ent. ii. pl. iii. figs. 2, 3 (1773).

♂ ♂, Mgana, 13th August, 1896.

These are the first examples from Eastern Africa which I have hitherto seen; unfortunately only one pair was obtained.

61. *LYCENESTHES AMARAH*.

Polyommatus amarah, Guérin in Lefebvre's Voy. Abyss. vi. p. 384, pl. 11. figs. 5, 6 (1847).

♂, Mgana, 12th July, 1896.

62. *ZERITIS AMANGA*.

Zeritis amanga, Westwood in Oates's Matabele-land, p. 351 (1881).

♀, Taru, 20th December, 1896; ♂, Voi, 2nd May, 1897.

The specimen of the female differs from our single imperfect Abyssinian example in the pattern of the primaries; the male, however, undoubtedly varies not a little.

63. *ZERITIS HARPAX*.

Papilio harpax, Fabricius, Syst. Ent., App. p. 829 (1775).

♂ ♀, Mwachi River, June 7th; ♀, Mgana, August 30th, 1896.

Var.? ♂ with red patch on primaries confined to internal area; secondaries of both sexes slightly less heavily bordered; silver spotting on under surface of secondaries considerably less prominent and (in the female) on a paler background.

♂ ♀, Mgana, 12th July, 1896.

It is just barely possible that the variety noted above may be distinct from typical *Z. harpax*, but I do not believe it is 'so; we have received the same form from Nyasaland. I also do not believe it possible to separate *Z. perion* from *Z. harpax*, the differences given to distinguish them by Mr. Trimen being undoubtedly unreliable.

LEPTOMYRINA, gen. nov.

Nearly related to typical *Myrina* (*M. silenus*, &c.), having the same general wing outline and neuration; it differs in its comparatively longer and far more slender antennæ with abruptly thickened club, rather more slender palpi, and the considerably shorter and more delicate tails to the secondaries. Type *L. phidias*, Fabr. (*rabe*, Boisd.).

64. LEPTOMYRINA HIRUNDO.

Thecla hirundo, Wallengren, Kongl. Svenska Vetensk.-Akad. Handl. 1857, p. 35 (*Amblypodia h.*); Trimen, Rhop. Afr. Austr. ii. p. 230, pl. 4. fig. 11 (1866).

Maungu Inkubwa, 21st March, 1897.

This is the most southern example of *L. hirundo* that I have heard of; our two examples are both from Natal.

65. VIRACHOLA LIVIA ?

Lycæna livia, Klug, Symb. Phys. pl. 40. figs. 3-6 (1834).

♂, Mgana, 12th July, 1896.

The male is somewhat shattered, but differs remarkably from Arabian examples, all the markings below being bright mahogany-red with blackish margins and whitish borders; the internal area of primaries buff.

66. VIRACHOLA LORISONA, var.

Myrina lorisona, Hewitson, Ill. Diurn. Lep. p. 37, pl. 16. figs. 48, 49 (1863).

♂, Mgana, 12th July, 1896.

The single example obtained differs so much from Hewitson's type in the pattern of the upper surface, that, if we had not possessed an intermediate specimen from West Africa, I should have concluded that this Eastern variety must be distinct: the secondaries would be best described as bright orange tawny, the base, abdominal border, and a submedian streak smoky greyish brown; the usual bright blue subcostal sexual spot; outer border narrowly dark brown, slightly widest at apex: the orange patch on the primaries is also much larger than in typical *V. lorisona*. This is the first example which I have seen from East Africa.

67. VIRACHOLA DIOCLES.

Deudorix diocles, Hewitson, Ill. Diurn. Lep., Suppl. p. 12, pl. v. figs. 55, 56 (1869).

♂, Mgana, 26th July; ♀, Mayeras, 20th July, 1896.

A single pair of this rare species was obtained; it is new to the general Collection. The female above is smoky greyish-brown, the primaries with a diffused ashy patch between the cell and the submedian vein; the secondaries with a similar patch on the median and lower radial interspaces; the anal lobe is externally golden orange, the usual internal black spot being sprinkled with silvery blue scales: otherwise, excepting in its rounder wings, it much resembles females of *V. livia*.

68. VIRACHOLA DARIAVES.

Deudorix dariaves, Hewitson, Ent. Month. Mag. xiii. p. 205 (1877).

♂, Mgana, 23rd July, 1896.

Also new to the general Collection.

69. VIRACHOLA ANTALUS.

Dipsas antalus, Hopffer, Monatsb. königl. Akad. Wissensch. Berlin, 1855, p. 641.

Sithon antalus, Peters's Reise n. Mossamb., Ins. p. 400, pl. xxv. figs. 7-9 (1862).

♂ ♀, Mgana, 13th August, 1896.

70. IOLAUS PHILIPPUS.

Hesperia philippus, Fabricius, Ent. Syst. iii. 1, p. 283 (1793).

♀, Mgana, 13th August; ♂ ♀, Taru, 19th December, 1896; ♂ ♂ ♀ ♀, Mombasa, 7th January, 1897.

71. IOLAUS PACHALICUS.

Hypolycæna pachalica, Butler, P. Z. S. 1888, p. 69.

♀, Chanjamwe, British East Africa, 31st May; ♂ ♂, Taru, December 20th, 1896; Mombasa, 7th January, 1897.

72. ARGIOLAUS SILABUS.

Iolaus silarus, H. H. Druce, Ent. Month. Mag. vol. xxii. p. 154 (1885).

♂ ♂, Taru, 18th December, 1896, and 1st February, 1897; ♀, Ndara Hills, 7th April, 1897.

This beautiful species, of which unfortunately only three examples were obtained, is quite new to the Museum collection.

PAPILIONIDÆ.

73. MYLOTHRIS AGATHINA.

Papilio agathina, Cramer, Pap. Exot. iii. pl. ccxxxvii. D, E (1782).

♂ ♀, Mgana, 2nd & 6th August; Taru, 16th December, 1896.

74. NYCHITONA MEDUSA, var. ALCESTA.

Papilio alcesta, Cramer, Pap. Exot. iv. pl. cclxxix. A (1782).

Mgana, 22nd June, 2nd & 11th August, 1896; Mombasa, 4th January; Maungu Inkubwa, 21st March, 1897.

After arranging the fine combined series of the Museum and Godman and Salvin collections, I have been forced to the conclusion that, at most, the genus *Nychitona* consists of two very variable species—*N. medusa* (African) and *N. xiphia* (Asiatic): but, even then, several of the forms of each species are barely, if at all, distinguishable. In Kirby's Catalogue Cramer's incorrect locality 'Coast of Bengal' is adopted for *N. medusa*; but the insect figured is of a purely African variety and was probably received from Sierra Leone.

75. TERIAS BRIGITTA, var. ZOE.

Terias zoe, Hopffer, Ber. Verh. Akad. Berl. 1855, p. 640; Peters's Reise n. Mossamb. v. p. 369, pl. 23. figs. 10, 11 (1862).

♂, Chanjamwe, 28th July, 1896; ♂, Manjewa, 13th January, 1897.

76. *TERIAS SENEGALENSIS.*

Terias senegalensis, Boisduval, Sp. Gén. Léop. i. p. 672 (1836).

♂ ♂, Taru, 16th & 19th December, 1896.

Var. *BISINUATA*, Butler, Ann. & Mag. Nat. Hist. ser. 4, vol. xviii. p. 485 (1876).

♀ Samburu, 15th November, 1896.

77. *TERACOLUS CALAIS.*

Papilio calais, Cramer, Pap. Exot. i. pl. liii. C, D (1779).

♂ ♀, Taru, 13th & 18th December, 1896; Voi, 1st May, 1897.

78. *TERACOLUS ERIS.*

Pontia eris, Klug, Symb. Phys., Ins. pl. vi. figs. 15, 16 (1829).

♀. *Teracolus abyssinicus*, Butler, Ann. & Mag. Nat. Hist. ser. 4, vol. xviii. p. 486 (1876).

Wet form. ♂ ♂ ♀ ♀, Taru, 22nd November, 13th, 16th, 19th, & 20th December, 1896; 17th January, 1897.

Intermediate form. ♂ ♂ ♀, Maziwa-ya-Tayau, 16th February, 1897.

The eighteen examples obtained by Mr. Betton show the usual uniformity of pattern characteristic of the Northern species of this group, and are all readily separable from the Southern, East-Central, and Western species, which Mr. Marshall proposed to unite under one name: only one example of the yellow female (to which I gave the name of *T. abyssinicus*) was obtained; indeed yellow females of the *T. eris* group seem to be rare.

79. *TERACOLUS PUNICEUS.*

♂. *Teracolus puniceus*, Butler, P. Z. S. 1888, p. 72; ♂ ♀, 1894, pl. xxxvi. figs. 5, 6.

♂ ♂, Taru, 16th & 18th December, 1896.

80. *TERACOLUS HETÆRA.*

♂. *Callosune hetæra*, Gerstaecker, Arch. für Naturg. 1871, p. 357; Von der Decken's Reisen in Ost-Afrika, iv. 2, p. 365, pl. xv. fig. 2 (1873).

♂ ♂ ♀ ♀, Taru, 16th, 18th, & 20th December, 1896.

The wet form of the male and the yellow form of the female of this species are new to the Museum series. Most of the specimens are of wet or intermediate types, but one female combines a wet-season upper surface with an extreme dry form of under surface.

81. *TERACOLUS IMPERATOR.*

Teracolus imperator, Butler, P. Z. S. 1876, p. 132.

♂ ♂, Mgana, 28th August; ♀, Samburu, 15th November; ♂ ♂ ♀ ♀, Taru, 18th to 20th December, 1896.

A ♀ whitish-spotted black-tipped form of the wet-season phase

as well as a magenta-glossed crimson-tipped example (both new to me) were in the series.

82. *TERACOLUS BETTONI*, sp. n.

♂. *Teracolus phlegyas* (part), Butler, cf. P. Z. S. 1894, p. 574.

This species at all seasons differs from the preceding in the extremely narrow and much more glistening lilac apical patch or band on the primaries of the male, its black inner edging almost or wholly wanting, and in the deep indentation or complete separation of the internal black stripe on the primaries of the female; the latter sex is either white or yellow, the apical area being either crossed by an orange patch or a row of white spots as in *T. imperator*. The dry form of the male differs chiefly from the wet form in the rosy colouring of the apex of the primaries and the whole surface of the secondaries on the under surface, whilst extreme wet types of the male are not only pearly white below, but show an oblique discal series of black spots between the costal vein and second median branch on the underside of the secondaries: the female of the dry phase resembles the wet form of *T. phlegyas* on the upperside and the dry form of that species on the underside; it is, however, larger and shows heavier black markings. Expanse of wings, ♂ 58–71 millim., ♀ 62–69 millim.

Wet form. ♂♂ ♀♀, Taru, 24th & 25th November, 15th, 18th, 19th, & 20th December, 1896 (one pair taken *in copulâ*).

Intermediate form. ♂, Mgana, 2nd August, 1896.

Small, and with white unspotted under surface.

Dry form. ♀, Ndara Hills, 7th April, 1897.

Fifteen examples were in Mr. Betton's collection.

83. *TERACOLUS INCRETUS*.

Teracolus incretus, Butler, Ent. Month. Mag. xviii. p. 146 (1881).

♀♀, Mgana, 30th August, and Samburu, 15th November; ♂, Taru, 18th December, 1896.

84. *TERACOLUS EVARNE*.

Pontia evarne, Klug, Symb. Phys. pl. vi. figs. 1–4 (1829).

Wet form. ♂♂, Mombasa, 7th January, 1897.

Intermediate form. ♂, Mgana, 27th June, 1896 (= *T. syrтинus*).

Dry form. ♂, Voi, 4th July, 1897 (= *T. citreus*).

85. *TERACOLUS HEUGLINI* (vars. *T. THRUPPI* & *JACKSONI*).

Teracolus thruppi, Butler, P. Z. S. 1885, p. 770, pl. xlvii. fig. 10 (Intermediate form.)

Teracolus jacksoni, E. M. Sharpe, Ann. & Mag. Nat. Hist. ser. 6, vol. v. p. 336 (1890). (Wet form.)¹

¹ The two forms seem to occur together at the commencement and end of the wet season, so far as I can judge; but they differ very little. A more marked intermediate form may perhaps exist.

♂ ♀, Mgana, 19th July, 13th & 30th August; ♂, Samburu, 26th October; ♂ ♂ ♀ ♀, Taru, 13th, 18th, & 20th December, 1896.

86. *TERACOLUS XANTHUS*.

Teracolus xanthus, Swinhoe, P. Z. S. 1884, p. 440, pl. xxxix. fig. 10.

Wet form. ♂ ♂, Taru, 13th & 20th December, 1896; Mombasa, 7th January, 1897.

Intermediate form. ♂ ♂, Samburu, 26th October and 6th November, 1896.

87. *TERACOLUS ANTEVIPPE*.

Anthocharis antevippe, Boisduval, Sp. Gén. Lép. i. p. 572 (1836).

Extreme wet form (var. *subvenosus*, Butler). ♂ ♂, Mgana, 28th August, 1896; Mombasa, 7th January; Manjewa, 13th January, 1897.

88. *TERACOLUS GAVISA*.

Anthopsyche gavis, Wallengren, Lep. Rhop. Caffr. p. 13 (1857).

♂ ♀, Samburu, 15th November; ♀, Taru, 18th December, 1896.

89. *TERACOLUS EXOLE*.

Anthocharis exole ♂, Reiche, Ferr. & Gal. Voy. Abyss. pl. xxxi. fig. 4 (1849).

Intermediate form (var. *roxane*, Felder). ♂ ♀, Taru, 22nd November and 16th December, 1896.

As these were sent in one envelope it is probable that they were taken *in coitu*. This is an argument in favour of the distinctness of *T. exole* from *T. omphale*: the male is imperfect.

90. *TERACOLUS OMPHALE*.

Pieris omphale, Godart, Enc. Méth. ix. p. 122 (1819).

Wet form. ♂ ♂, Mgana, 13th & 28th August; Samburu, 1st November; ♀, Taru, 13th December, 1896; ♂, Mombasa, 7th January; Maungu Inkubwa, 21st March, 1897.

91. *TERACOLUS PSEUDACASTE*.

Teracolus pseudacaste, Butler, P. Z. S. 1876, p. 156, pl. vi. fig. 11.

Intermediate form. ♂ ♂, Samburu, 26th & 28th October, 6th November; ♂ ♀, 15th November, 1896.

Wet form. ♂ ♂, Taru, 16th December, 1896; Mombasa, 7th January, 1897, ♀ same date.

The female from Mombasa is the blackest and most interesting variety that I have seen.

92. *TERACOLUS LEO*.

Teracolus leo, Butler, Ann. & Mag. Nat. Hist. ser. 3, vol. xvi. p. 397 (1865).

Wet-season form. ♀, Taru, 19th December, 1896.

Dry-season form. ♀, Mbuyuni, 14th June, 1897; ♂ ♂, Voi, 4th July, 1897.

The dry form is quite new to science (excepting for the single starved and faded male without locality noted in my Revision of the genus, *cf.* Ann. & Mag. Nat. Hist. ser. 6, vol. xx. p. 501, 1897). The male at this season chiefly differs from that of the wet-season in the bluer tint of the grey basal area of the primaries, but the orange is sometimes carried above the first median branch and the dusky submarginal markings are sometimes wanting; the underside differs in its flesh-coloured suffusion, which is very well-defined at apex of primaries and over the basal, costal, and internal areas of the secondaries. The female of the dry form resembles *T. caelestis* of Swinhoe (the dry form of the female of *T. halimede*), but has the discal black spots across the primaries widely separated from the outer border by a broad intervening belt of the yellow ground-colour: on the underside the apex of the primaries and the whole of the secondaries are fleshy brown, and the transverse spots are much darker than in *T. caelestis*.

93. *TERACOLUS VENOSUS*.

♂. *Idmais venosa*, Staudinger, Exot. Schmett. p. 43, pl. xxiii. (1885); ♀, Holland, Proc. U.S. Nat. Mus. vol. xviii. p. 759 (1896).

♂ ♂ ♀ ♀, Taru, 22nd November; 13th, 16th, 18th, & 19th December, 1896.

This species was badly needed for the Museum series; therefore I was pleased to find that Mr. Betton had secured a fair number of specimens.

94. *TERACOLUS HELVOLUS*, var.

Teracolus helvolus, Butler, P. Z. S. 1888, p. 94.

♀, Mbuyuni, 7th April; ♂, Voi, 25th April; between Voi and Ndi (88 miles from Mombasa), 16th May; Voi, 4th July, 1897.

These specimens are particularly interesting; they are almost as large as *T. aurigineus*, but of the exact pattern and coloration of the dry form of *T. helvolus*. We have corresponding examples of the wet form obtained at Kilimanjaro; a specimen of the latter from Mombasa, however, scarcely differs in size from Somali examples.

95. *TERACOLUS CATACHRYSOPS*.

Teracolus catachrysops, Butler, Ann. & Mag. Nat. Hist. ser. 5, vol. ii. p. 178 (1878).

Dry form. ♀, Chanjamwe, 18th June, 1896.

Wet form. ♂ ♂ ♀, Mombasa, 4th January, 1897.

I now have another proof of the absurdity of calling this very distinct species a variety of *T. mutans*, inasmuch as the dry form is seen to differ from the wet chiefly in the redder colouring of the bands on the under surface, whereas in *T. mutans* the whole under surface of the secondaries and of the apex of primaries becomes clay-coloured with a pink suffusion, the bands being indistinct.

96. TERACOLUS PROTOMEDIA.

Pontia protomedia, Klug, Symb. Phys., Ins. pl. viii. figs. 13, 14 (1829).

♂ ♂ ♀, Taru, 20th December, 1896.

97. CATOPSILIA FLORELLA.

Papilio florella, Fabricius, Syst. Ent. p. 479 (1775).

♂, Chanjamwe, 10th June; ♂ ♀, Taru, 18th & 19th December, 1896; ♂ ♀, Maungu Inkubwa, 21st March; ♂ ♂, Ndara Hills, 6th & 7th April, 1897.

98. PHRISSURA LASTI.

Mylothris lasti, Grose-Smith, Ann. & Mag. Nat. Hist. ser. 6, vol. iii. p. 124 (1889); Rhop. Exot. ii. *Belén*. pl. ii. figs. 1-3 (1892).

♂, Mgana, 26th July; ♂ ♀, 13th August, 1896.

99. BELENOIS THYSA.

Pieris thysa, Hopffer, Ber. Verh. Akad. Berl. 1855, p. 639; Peters's Reise n. Mossamb., Ins. p. 349, pl. xxi. figs 7-10 (1862).

♂ ♀, Mgana, 2nd August, 1896.

100. BELENOIS CREONA.

Papilio creona, Cramer, Pap. Exot. i. pl. xcv. C-F (1779).

♂ ♀, Mgana, 13th July; ♂ ♂, Chanjamwe, 28th July; Taru, 20th December, 1896; and Voi, 1st May, 1897.

101. BELENOIS MESENTINA, var. LORDACA.

Pieris lordaca, Walker, Entomologist, 1870, p. 48.

♂ ♂ ♀ ♀, Maziwa-ya Tayau, 8th to 17th February, 1897.

Mr. Betton took no less than twenty-eight examples of this abundant species, most of them having been caught on the 16th February.

102. BELENOIS GIDICA.

Pieris gidica, Godart, Enc. Méth. ix. p. 131 (1819).

♂ ♂, Mgana, 28th June; Taru, 18th & 19th December, 1896; Maungu Inkubwa, 21st March, 1897.

All four specimens (including that obtained at the end of June) are of the wet-season phase.

103. *GLUTOPHRISSA CONTRACTA*, var.

Glutophrissa contracta, Butler, P. Z. S. 1888, p. 75.

Dry form. ♂ ♀, Mgana, 12th July, 1896.

A rather shattered pair was obtained, but the specimens are of great interest to us as showing the seasonal modification of the species. The dry form somewhat resembles *G. flavida* of Madagascar (which is doubtless the dry form of *G. malatha*), but it differs in the well-defined outer border on the upperside of the secondaries and in the character of the male, which does not differ from wet-season examples of *G. contracta*.

104. *PINACOPTERYX LILIANA*.

Belenois liliana, Grose-Smith, Ann. & Mag. Nat. Hist. ser. 6, vol. iii. p. 122 (1889); Rhop. Exot. ii. pl. i. figs. 7-9 (1893).

♂. Mgana, 22nd June; ♀, Samburu, 15th November, 1896.

105. *HERPÆNIA MELANARGE*.

Herpænia melanarge, Butler, P. Z. S. 1885, p. 774.

Herpænia iterata, Butler, P. Z. S. 1888, p. 96.

Dry-season form (*H. melanarge*). ♂, Mgana, 26th July, 1896.

Wet-season form (*H. iterata*). ♀, Taru, 22nd November, ♂ 16th December, ♀ 19th December, 1896.

106. *LEUCERONIA BUQUETII*.

Callidryas buquetii, Boisduval, Sp. Gén. Lép. i. p. 607 (1836).

Taru, 13th, 19th, & 20th December, 1896; Voi, 1st May, 1897.

107. *ERONIA DILATATA*.

Eronia dilatata, Butler, P. Z. S. 1888, p. 96.

Mgana, 6th, 11th, & 30th August; Samburu, 26th October; Taru, 22nd November, 13th & 16th December, 1896; Maungu Inkubwa, 21st March, 1897.

The dry form has slightly narrower black borders to the wings and a slightly deeper-coloured underside than the wet form.

108. *ERONIA LEDA*.

Dryas leda, Boisduval, App. Voy. de Deleg. p. 588 (1847).

♂ ♂ ♀, Maungu Inkubwa, 21st March, 1897.

109. *PAPILIO CORINNEUS*.

Papilio corinneus, Bertoloni, Mem. Acc. Bologna, 1849, p. 9, pl. i. figs. 1-4.

Chanjamwe, 14th June, 1896; Mombasa, 4th January, 1897.

110. *PAPILIO PHILONOE*.

Papilio philonoe, Ward, Ent. Month. Mag. x. p. 152 (1873).

Mombasa, 7th January; Maungu Inkubwa, 21st March, 1897.
Proc. Zool. Soc.—1898, No. XXVIII.

111. *PAPILIO DEMOLEUS*.

Papilio demoleus, Linnæus, Mus. Lud. Ulr. p. 214 (1764).

Taru, 18th & 20th December, 1896; Mombasa, 4th January; Maungu Inkubwa, 21st March; between Voi and Ndi, 19th May, 1897.

112. *PAPILIO CONSTANTINUS*.

Papilio constantinus, Ward, Ent. Month. Mag. viii. p. 34 (1871); Afric. Lep. i. pl. i. figs. 1, 2 (1873).

Two pairs, Maungu Inkubwa, 21st March, 1897.

113. *PAPILIO NIREUS*.

Papilio nireus, Linnæus, Mus. Lud. Ulr. p. 217 (1764).

♀, Mombasa, 4th January; ♂ ♂ ♀, Maungu Inkubwa, 21st March, 1897.

I must confess that I see no possible reason for separating this variable species under two distinctive names.

114. *PAPILIO MEROPE* (var. *DARDANUS*, Brown).

Papilio merope, Cramer, Pap. Exot. ii. pl. cli. A, B (1779).

♂ ♂ ♀, Maungu Inkubwa, 21st March, 1897.

Although I do not consider that the Eastern type should be regarded as identical with the Western, it is more convenient (until the forms of so-called *P. merope* have been thoroughly studied) to retain this name for them all. The Southern form is apparently identical with the Eastern one, but the true *P. merope* of Cramer seems to me to be the West-African type with black-and-white female. The corresponding Eastern form is that now received, the female being also of the black-and-white type, but the male differing in constantly having a broad continuous black belt across the secondaries; it thus comes nearest to the male of *P. cenea*, which Mr. Trimen regards as a variety of the same species; perhaps he has proved this point, but it seems odd for the same insect to mimic two totally dissimilar *Danaïnae*.

HESPERIIDÆ.

115. *SARANGESA ELIMINATA*.

Sarangesa eliminata, Holland, P. Z. S. 1896, p. 9, pl. v. fig. 2.

Taru, 22nd November and 20th December, 1896; Voi, 22nd April, 2nd May, and 22nd June, 1897.

The specimen obtained on the 22nd April is a distinct intergrade to *S. pertusa*, and I believe, when the species of this group are better understood, it will be found impossible to separate most of the species of the *S. motozi* group; they are simply ridiculously close, whilst (so far as I can judge from our poor series) they probably all occur together. We have *S. pertusa*, *S. synestalmenus*, and *S. motozioides* occurring with *S. motozi* in Nyasaland; *S. per-*

tusa and *S. motozi* in South Africa; *S. pertusa* var. and *S. eliminata* in British East Africa at the same spot; we have *S. pertusa* from Aden, and *S. eliminata* from Abyssinia. Altogether these forms do not look like good distinct species.

116. SARANGESA DJÆLÆLÆ.

Pterygospidea djælcæla, Wallengren, Kongl. Svensk. Vetensk.-Akad. Handl. 1857; Lep. Rhop. Caffr. p. 54.

Maungu Inkubwa, 21st March, 1897.

117. PYRGUS BETTONI, sp. n. (Plate XXXII. fig. 1.)

Nearest to *P. zebra* and *P. asterodia*, but not very closely allied to any African species known to me, and on the upper surface somewhat resembling the New-World *P. asychis*. Upper surface black-brown; a white spot near the base of each discoidal cell; a central interrupted white belt, not reaching the borders of the wings, commencing with a subcostal dot on the primaries, where it is divided into three quadrate spots by the first and second median branches, oblique and terminating in a subconfluent dot on the secondaries; a transverse trifold subapical white bar on the primaries, and a single small spot on the second median interspace; submarginal series of dots unequal, the first, second, and fifth extremely minute; in the secondaries the first, fourth, fifth, and sixth extremely minute; fringe white, varied with blackish at the extremities of the veins: body normal. Primaries below dark greyish, but with the usual copper-brown reflections; white spots broader and more confluent than above, internal border greyish white; secondaries with the basal two-thirds and abdominal border white; a spot across the base of the cell and a broad irregular oblique belt from near base of costa across the cell, a short central costal streak and a spot just below the latter, greyish olivaceous; external third occupied by a broad belt of the same colour, slightly flecked with whitish and grey at apex and towards anal angle (so as vaguely to indicate the pale outer border which occurs in *P. zebra*); fringe of all the wings white, spotted with grey. Body below sordid white, the venter rather purer than the pectus. Expanse of wings 24 millim.

Maungu Inkubwa, 21st March, 1897.

118. PYRGUS DROMUS.

Pyrgus dromus, Plötz, Mitth. naturw. Vereins, 1884, p. 6.

Mgana, 30th August, 1896.

Unfortunately only a single example of this pretty little *Pyrgus* was obtained.

119. PAROSMODES ICTERIA.

Pamphila icteria, Mabille, C.R. Soc. Ent. Belg. vol. xxxv. p. clxxx (1821).

Mgana, 5th July, 13th & 30th August, 1896.

120. BAORIS FATUELLUS.

Pamphila fatuellus, Hopffer, Monatsber. k. Akad. Wissensch. Berl. 1855, p. 643; Peters's Reise n. Mossamb., Ins. p. 417, pl. xxvii. figs. 3, 4 (1862).

Mwachi River, 7th June, 1896.

121. BAORIS AURITINCTUS, sp. n. (Plate XXXII. fig. 2.)

Form of *B. fatuellus*, primaries with exactly similar transparent white spots; an elliptical patch below the median vein and the commencement of its first branch, a small spot above the submedian vein (representing the white spot frequently present in *B. fatuellus*), and a pilose internal streak bronzy ochraceous, the whole wing-surface also glossed with golden bronze: secondaries more distinctly glossed with golden, the long hair clothing the discoidal and internal areas to the centre of the disc being bronzy ochraceous; two unequal subapical transparent yellowish spots placed obliquely; fringes of all the wings smoky brown, tipped with bone-white excepting towards apex of primaries. Body of the ordinary type, blackish with bronzy green reflections on head and thorax and golden cupreous reflections on abdomen; a shoulder-spot and a spot on each side of the head, close to the eyes, ochreous; antennæ bronze tipped with purplish black. Under surface brownish grey, densely irrorated with ochraceous excepting on the internal areas: otherwise very like *B. fatuellus*. Expanse of wings 34 millim.

Taru, 20th December, 1896.

Only one example obtained.

122. CERATRICHIA STELLATA.

Ceratrichia stellata, Mabilie, C.R. Soc. Ent. Belg. 1891, p. lxxv. Mgana, 13th & 28th August, 1896.

I quite agree with Dr. Holland that this species differs from typical *Ceratrichia* in its shorter antennæ, &c., but I do not like it a bit better in *Cyclopides* (which it is not half so much like in pattern). As Dr. Holland has not proposed a new generic location for it, I prefer, for the present, to let the species rest where M. Mabilie placed it.

123. RHOPALOCAMPTA FORESTAN.

Papilio forestan, Cramer, Pap. Exot. iv. pl. cccxci. E, F (1782). Ndara Hills, 7th April, 1897.

The Moths in the collection are not in such good condition as the Butterflies, but most of them are recognizable; some are of great beauty and quite new to the Museum collection; others we had previously only received from South Africa or from the West coast. As might be expected, not a few are new to science. The following is as complete an account of them as could be made.

II. HETEROCERA.

SYNTOMIDÆ.

124. *APISA CANESCENS*.

Apisa canescens, Walker, Lep. Het. iv. p. 917 (1855).

Camp near 119 miles inland from Mombasa, 7th July, 1897.

The single female example is smaller than any example of that sex which I have hitherto seen, but we have no East-African specimens obtained further north than Natal. It is just possible that this may be a small race of the species, as Sir George Hampson informs me that he has seen a male from East Africa still smaller than the female now received.

125. *EUCHROMIA AMÆNA*.

Euchromia amœna, Moeschler, Stett. ent. Zeit. xxxiii. p. 350 (1872).

Mayera, 17th July; Taru, 20th December, 1896.

This is the species which I called *E. africana*; Herr Moeschler erroneously gave Silhet as its habitat.

ARCTIIDÆ.

126. *ALOA BIVITTATA*, sp. n. (Plate XXXII. fig. 3.)

Most nearly allied to *A. punctistriga* from India. Primaries cream-coloured, the costal border and veins pale testaceous; a black dot at base of submedian veins, and a black dot on the lower discocellular vein pierced by a longitudinal blackish-brown streak which runs to outer margin; a second short and more slender streak, in the areole above it, also running to outer margin; secondaries pure white. Antennæ white with black pectinations; head ochreous, becoming chalky white at sides and back of collar; thorax chalky white; abdomen ochreous, white at base and with dorsal transverse black bars, of which the first and seventh are widest and the fourth to sixth most delicate; a black spot on each side of anal segment. Wings below white, the primaries with buff costal borders; pectus white, smoky brown in front; legs smoky brown, the hind femora pale ochreous in front; venter white, with a blackish lateral stripe not extending over the last two segments. Expanse of wings 41 millim.

Mbana, 28th June, 1896.

Only one example was obtained.

127. *LACYDES ARBORIFERA*.

Lacydes arborifera, Butler, Cist. Ent. ii. p. 26 (1875).

Samburu, 1st November, 1896.

Previously only recorded from West Africa.

128. *LACYDES GRACILIS*, sp. n. (Plate XXXII. fig. 4.)

♀. Allied to *L. vocula* and *L. smithii* (*Conchylia smithii*, Holland):

primaries comparatively narrower¹, pale cupreous brown; a silvery white costal streak from base tapering to a point just before the basal third; the remainder of costal area unmarked almost to apex, where a silvery white band commences, runs obliquely to the upper radial (vein 6), where it joins a longitudinal discoidal streak tapered at each extremity and commencing in the cell just beyond the termination of the costal streak; a longitudinal interno-median streak tapering towards the base and confluent on outer margin, with a short narrower stripe above the first median branch, thus forming a kind of L-shaped character; above the latter along the outer border is a cuneiform patch of silvery white, deeply incised at third median branch; base of internal border white, terminated by an oblique spot of brown slightly darker than the ground-colour, beyond which is a whitish patch; secondaries pearly white, unspotted. Body much rubbed, but probably very similar to that of *L. vocula*. Under surface of wings as above, excepting that the ground-colour of the primaries is a little paler and greyer. Expanse of wings 35 millim.

Marago ya Fundi, Taru desert, 2nd March, 1897.

Unfortunately only one example was obtained, but it seems to differ too much from either of the species above noted to be a variety; the absence of the white costal markings and the much more regular character of the markings seem likely to be trustworthy distinctions.

I am quite unable to identify the following with any genus of *Lithosiinae*:—

BETTONIA, gen. nov.

Nearest to *Dictenus* (Butl.), general aspect of *Eubaphe*; the palpi extremely small, slender, directed forwards; proboscis short but well-developed; antennæ (of female) about one-third the length of primaries, simple, somewhat thick; primaries elongate-triangular, costal vein running to second third of costa; subcostal five-branched, the second and third from a long footstalk, the fourth and fifth from a short footstalk; secondaries with the subcostal branches from a long footstalk; the other veins all well separated at their origins. Type *B. ferruginea*.

129. BETTONIA FERRUGINEA, sp. n. (Plate XXXII. fig. 5.)

♀. Tawny ferruginous; primaries above with a slightly greyish tinge and a black spot in the centre of the discoidal cell; all the wings with a black discocellular spot. Expanse of wings 20 millim.

♀, Voi, 2nd May, 1897.

130. LEXIS BIPUNCTIGERA.

Lithosia bipunctigera, Wallengren, Wien. ent. Monatschr. 1860, p. 45.

¹ This is, however, probably only a sexual character.

Lexis bipunctigera, Wallengren, *l. c.* 1863, p. 146.

Setina quadrinotata, Walker, Cat. Lep. Het. xxxi. p. 237 (1864).

♀, Maungu Inkubwa, 21st March, 1897.

Of this species we only possess Walker's rather imperfect type from Natal; it is, therefore, a welcome addition.

The genus *Lexis* is allied to *Sozuza*, although the pattern of *L. bipunctigera* ♀ reminds one rather forcibly of that of *Æonistis quadra* ♀ (to which it is certainly not closely related). It is characterized as distinct from *Sozuza* by the absence of the post-discoidal areole (or false cell) in the primaries, by the much greater length of the costal vein, with which the first subcostal branch anastomoses; the third and fourth branches emitted as in *Sozuza*, but the fifth branch emitted from the fourth instead of from before the emission of the third. In the secondaries the so-called second and third median branches (now recognized as the second median and lower radial) form a much shorter furca than in *Sozuza*.

NYCTEMERIDÆ.

131. TERINA TENUIS.

Aletis tenuis, Butler, P. Z. S. 1878, p. 385.

Terina fulva, Hampson, Ann. & Mag. Nat. Hist. ser. 6, vol. vi. p. 183 (1891).

Mgana, 13th August, 1896.

A beautiful species of which we should have been glad to obtain examples; unfortunately Mr. Betton only secured one.

132. PITTHEA TRIFASCIATA.

Türkheimia trifasciata, Dewitz, Verh. Leop.-Carol. Akad. xlii. p. 82, pl. 3. fig. 3 (1881).

♀, Mgana, 13th August, 1896; ♂ ♀ ♀, Mombasa, 4th & 7th January, 1897.

133. SECUSIO STRIGATA.

Secusio strigata, Walker, Cat. Lep. Het. ii. p. 550 (1864).

Taru, ♀ ♀, 22nd November and 19th December, 1896.

134. LEPTOSOMA LEUCONOE.

Nyctemera leuconoe, Hopffer, Monatsber. königl. Akad. Wissensch. Berlin, 1857, p. 422; Peters's Reise n. Mossamb., Ins. p. 430, pl. xxviii. fig. 3 (1862).

Mgana, 22nd June and 12th July; Taru, 19th December, 1896.

135. LEPTOSOMA FALLAX?

Nyctemera fallax, Holland, Ent. News Philad. 1893, p. 59.

♂, Taru, 17th January, 1897.

We only have a single female of this species in the Museum collection; the present male does not seem to differ more from it than the sex would account for; but, as the type of *L. fallax* was

from the West, I feel no certainty of the specific identity of the two insects.

A G A R I S T I D Æ.

136. *ÆGOCERA TRICOLOR*.

Ægocera tricolor, Druce, Ent. Month. Mag. vol. xx. p. 155 (1883).

Samburu, 10th & 15th November, 1896; between Voi and Ndi, 22nd May, 1897.

The last example obtained is of interest on account of the distortion of the subapical patch across the right primary. It seems to me not at all unlikely that this may prove to be only a form of *Æ. leucomelas* with orange secondaries; a similar variation in colouring occurs in the very closely related *Æ. trimeni* and in *Æ. triplagiata*.

N O C T U I D Æ.

137. *EUPLEXIA OPPOSITA*.

Mamestra opposita, Walker, Cat. Lep. Het. xxxii. p. 667 (1865). Mbuyuni, 29th May, 1897.

138. *AMYNA SELENAMPHA*.

Amyna selenampha, Guenée, Noct. i. p. 406 (1852).

Samburu, 28th October, 1896.

One rather rubbed example of this abundant species was obtained.

139. *TARACHE UPSILON*.

Calophasia upsilon, Walker, Cat. Lep. Het. xxxiii. p. 763.

Samburu, 2nd November; Taru, 24th November, 1896, 21st January, 1897.

140. *TARACHE PORPHYREA*, sp. n.

General pattern of both sexes similar to that of *T. tropica*; coloration of primaries nearer to *T. ardoris* but more clouded. Primaries of male with the basal two-thirds bone-whitish, clouded and transversely banded with plumbeous grey, varied with olivaceous; a black spot at end of cell, but none in the cell, the pale area terminating beyond the cell in the usual pale-edged blackish olivaceous 3-shaped character impinging upon the external third, which is glistening sepia-brown; the external border faintly indicated excepting at the extremity of the median areoles and at the external angle, where it becomes whitish; the two patches connected internally by a zigzag whitish line; a marginal series of black dots, barely visible excepting upon the pale patches; secondaries silky smoke-brown, a little darker on outer border and slightly cupreous in certain lights. Thorax whitish, more or less varied with greyish; abdomen whitish or grey, that of the female sometimes grey, with the posterior borders of the segments buff.

Wings below glistening grey, the internal area of primaries whitish, the costal border and external margin in the female varied with ochreous; the secondaries in this sex also somewhat paler, slightly yellowish towards costa, especially from the middle, and crossed by an irregular oblique subapical grey band; a dark grey spot at end of cell: body below milk-white, tibiæ and tarsi barred with grey. Expanse of wings 19–20 millim.

♂ ♀, between Voi and Ndi, 88 miles from Mombasa, 4th June, 1897.

In 1884 we received a slightly smaller pair of this species from Accra; but these are all that I have seen of it.

141. TARACHE sp.

♀. Probably new, but too imperfect to describe; it is nearly related to a very beautiful unnamed female (also from British East Africa) in the Museum collection; but differs in so many details of colouring, that I cannot venture to regard it as a variety of that insect: also, in this genus, in which the sexes often differ to a marvellous degree, it is not satisfactory to describe from a female alone.

♀, between Voi and Ndi, 4th June, 1897.

142. TARACHE ADMOTA.

Acontia admota, Felder, Reise der Nov., Lep. v. pl. cviii. fig. 31 (1875).

Samburu, 31st October, 1896.

I have previously seen this insect from extreme North and from South Africa; but it is new to us from East Africa. In fresh examples the markings on the primaries are bright olive-green; the figure in the 'Novara Voyage' is not characteristic.

143. POLYDESMA UMBRICOLO.

Polydesma umbricola, Boisduval, Faune Ent. de Madag., Lép. p. 108, pl. 13. fig. 5.

♀ ♀, Voi, 2nd May and 16th July; between Voi and Ndi, 18th May, 1897.

Two damaged females of *Ericeia inangulata*, Guen., were obtained at Samburu (Oct. 26th) and Taru (Nov. 28th).

144. CYLIGRAMMA LATONA.

Phalæna (Noctua) latona, Cramer, Pap. Exot. i. p. 20, pl. xiii. B (1779).

Samburu, 17th & 20th November; Taru, 22nd, 24th, & 28th November, 6th & 9th December, 1896; between Voi and Ndi, 18th May, 1897.

145. CYLIGRAMMA FLUCTUOSA.

Phalæna (Noctua) fluctuosa, Drury, Ill. Exot. Ent. ii. p. 24, pl. xiv. fig. 1.

Var. *Cyligramma rudilinea*, Walker, Cat. Lep. Het. xiv. p. 1311 (1857).

Var. *Cyligramma limacina*, Guérin, Icon. Règne Anim., Ins. pl. 89. fig. 2, texte p. 520.

Mgana, 5th & 6th August; three miles north of Samburu, 23rd October; Taru, 20th, 22nd, 23rd, 24th, & 28th November, 1896.

Three examples agreeing with *C. limacina*, the remainder intermediate between the latter and *C. rudilinea*; therefore typical. This form of the species is new to the Museum collection.

146. *DYSGONIA ABNEGANS*, var.

Ophiusa? abnegans, Walker, Cat. Lep. Het. xv. p. 1831 (1858).

Mgana, 27th July and 30th August, 1896.

Neither of the two specimens obtained quite agrees with Walker's type from Sierra Leone, though one is nearer than the other. It is very important to secure these aberrant examples, as only thus can we hope to comprehend the variability of the species in this genus (which at times is considerable). I am quite satisfied that *D. neptunia* of Holland is Walker's *D. conjunctura*, and I am not at all certain that *D. palpatis* of Walker is more than a variety of the same species.

In the Eastern specimens of *D. abnegans* before me the band forming the inner limitation of the bicoloured central belt on the primaries is less inarched at costa, though more so in one example than in the other; the subapical markings vary individually.

147. *DYSGONIA ANGULARIS*.

Ophiusa angularis, Boisduval, Faune Ent. de Madag., Lép. p. 103, pl. 13. fig. 2.

Mgana, 27th July, 1896; Mombasa, 8th January; between Voi and Ndi, 18th May, 1897.

New to the Museum series from Eastern Africa.

148. *ACHEA LIENARDI*.

Ophiusa lienardi, Boisduval, Faune Ent. de Madag., Lép. p. 102, pl. 15. fig. 5.

Taru, 20th December, 1896.

149. *GRAMMODES STOLIDA*.

Noctua stolidi, Fabricius, Sp. Ins. ii. p. 218.

Machuma, 21st February, 1897.

New to the Museum from East Africa.

150. *SPHINGOMORPHA MONTEIRONIS*.

Sphingomorpha monteironis, Butler, Ann. & Mag. Nat. Hist. ser. 4, vol. xvi. p. 406 (1875).

Mkwajuni, 20th & 21st October; three miles north of Samburu, 23rd October; Taru, 6th December, 1896.

151. *GNAMPTONYX TREFOLIATA*, sp. n.

General aspect of an *Acronycta*, but belonging to the quadrifid group of *Noctuidæ*. Primaries earthy brown, sprinkled all over with pale lavender scales; an ill-defined, dusky, oblique costal streak entering discoidal cell just above the orbicular spot, which is whitish, outlined in black; the reniform stigma is represented by a large irregular black-edged marking, not unlike a hawthorn or trefoil leaf with the mid-rib directed inwards to below the orbicular spot; an oblique costal streak at apical fourth, external border ashy lavender, its inner margin widely and deeply sinuated between costa and first median branch, but diffused below the latter; a vague indication of a dusky annulus on inner margin near external angle; a series of small black submarginal spots; fringe whitish, sprinkled with earthy-brown scales; secondaries sericeous white with a very faint fleshy tint; the external area dust greyish; a marginal series of black dashes; fringe white at base, greyish externally: head brownish grey, collar less brown, ashy in front and at the sides; thorax ashy; abdomen buffish white irrorated with grey. Wings below white, slightly buffish and irrorated with dark brown scales on costal and apical areas; a marginal series of blackish spots; secondaries with a dusky spot on upper discocellular: body below sordid buffish white; front of pectus, palpi and legs above brownish irrorated with blackish, the tarsi with white tips to the joints. Expanse of wings 60 millim.

Between Voi and Ndi, 2nd June, 1897.

Unfortunately only one example of this species was obtained. I am indebted to Sir George Hampson for pointing out its affinities; despite its dissimilarity from the type of his genus *Gnamptonyx*, it corresponds with it so closely in structure that I have no doubt of its correct location.

152. *BANIANA INTORTA*.

Baniana intorta, Swinhoe, Trans. Ent. Soc. 1891, p. 150; Hampson, Ill. Typ. Het. ix. pl. 163. fig. 3.

♀, Taru, 23rd November, 1896.

New to the Museum from Eastern Africa, though we have it from Natal and Accra.

153. *COLBUSA PENTAGONALIS*.

Colbusa pentagonalis, Butler, P. Z. S. 1894, p. 589, pl. xxxvii. fig. 8. Samburu, 7th November, 1896.

A larger and better example than the type, and therefore a desirable acquisition.

154. *TRIGONODES HYPASIA*.

Phalaena-Noctua hippasia, Cramer, Pap. Exot. iii. pl. ccl. E (1782).

Mbuyuni, 25th April; between Voi and Ndi, 20th & 22nd May; Voi, 26th June, 1897.

155. REMIGIA ARCHESIA.

Phalæna-Noctua archesia, Cramer, Pap. Exot. iii. p. 145, pl. cclxxiii. F, G (1782).

Mgana, 27th July and 18th August, 1896.

156. REMIGIA REPANDA.

Noctua repanda, Fabricius, Ent. Syst. iii. 2, p. 49 (1793).

Mgana, 27th July, 20th, 27th, & 30th August, 1896.

157. ENTOMOGRAMMA NIGRICEPS.

Renodes ? nigriceps, Walker, Cat. Lep. Het. xv. p. 1595 (1858).

Mgana, 5th August, 1896.

158. OPHIODES FINIFASCIA.

Nephelodes finifascia, Walker, Cat. Lep. Het. xv. p. 1676 (1858).

Taru, 4th February, 1897.

One imperfect example.

159. PASIPEDA ROSEIVENTRIS.

Asymbata roseiventris, Gerstaecker, in Von der Decken's Reisen in Ost-Afrika, iii. 2, p. 378, pl. xv. fig. 8 (1873).

♂, Voi, 30th April; ♀, between Voi and Ndi, 4th June, 1897.

The male is the first example of that sex which I have seen; the species seems to be rare, though nearly related to the common Indian *P. satellitia*; possibly it has simply not been collected.

160. HALASTUS DIVITIOSUS.

Ophideres divitiosa, Walker, Proc. Nat. Hist. Soc. Glasgow, vol. i. p. 356, pl. vii. fig. 11 (1869).

Machuma, 22nd February, 1897.

161. ARGADESA MATERNA.

Phalæna-Noctua materna, Linnæus, Syst. Nat. ii. p. 840 (1767).

♂, Samburu, 15th November, 1896; ♀, Maungu Inkubwa, 21st March, 1897.

162. COSMOPHILA EROSA.

Anomis erosa, Hübner, Exot. Schmett. Zutr. ii. p. 19, figs. 287, 288.

♀, Samburu, 16th November, 1896.

163. HYPOCALA DEFLOKATA, var. PLUMICORNIS.

Hypocala plumicornis, Guenée, Noct. iii. p. 75 (1852).

Samburu, 14th November, 1896.

164. PLUSIA ERIOSOMA.

Plusia eriosoma, Doubleday in Dieffenbach's New Zealand, i. p. 285 (1843).

Samburu, 7th, 8th, & 16th November; Taru, 22nd November & 20th December, 1896.

This abundant species seems to be almost cosmopolitan.

165. *RISOBA OBSTRUCTA*.

Risoba obstructa, Moore, P. Z. S. 1881, p. 328; Lep. Ceylon, iii. p. 2, pl. cxliv. figs. 2, 2 *a*, 2 *b* (1884).

Samburu, 2nd November, 1896.

This is quite new to the African fauna.

166. *GONITIS SABULIFERA*.

Gonitis sabulifera, Guenée, Noct. ii. p. 404 (1852).

Mgana, 30th August; Samburu, 31st October, 4th & 7th November; Taru, 24th, 27th, & 28th November, 9th December, 1896.

Many of the specimens belong to the variety named by Walker *G. involuta*. The species is new to us from East Africa, though we have it both from Abyssinia and Natal.

167. *MABASMALUS DISCISTRIGA*.

Eutelia discitriga (sic), Walker, Cat. Lep. Het. xxxiii. p. 823 (1865).

Samburu, 4th November; Taru, 1st December, 1896.

I have never previously seen this species from Eastern Africa, but we have it from Aden, and therefore it probably is to be found in the extreme North.

168. *ZETHES BETTONI*, sp. n.

Closely allied to *Z. hesperioides*, having exactly the same outline, structure, and nearly the same pattern; it is, however, distinctly smaller; the peculiar hatchet-shaped central belt across the primaries is pale buffish, flesh-tinted or greyish, with the borders of the lower half very black in fresh specimens; the pale costal dots are sometimes much whiter than in the species from Java and Burma, and the subquadrate costal patch towards apex paler and therefore less prominent; the submarginal line on all the wings is whitish with dark brown borders; on the under surface the resemblance to *Z. hesperioides* is again very great, but the basal area is paler, the narrow dark-bordered transverse central band usually paler, sometimes quite white, the discal belt sometimes much darker than in any specimens of the larger species. Expanse of wings, ♂ 31–32 millim., ♀ 29–32 millim.

Taru, 1st, 6th, & 9th December, 1896.

169. *EGNASIA VICARIA*.

Thyridospila vicaria, Walker, Cat. Lep. Het. xxxv. p. 1972 (1866).

Mgana, 1st August, 1896.

170. *RAPARNA LIMBATA*, sp. n.

♀. Primaries above pale coffee reddish, sericeous; the costal border whitly brown; external border narrowly and unevenly pale grey-brownish bounded internally by a partly zigzag, partly widely sinuous, white submarginal line, the latter bounded internally towards apex and towards external angle by a diffused dusky patch; central area of wing enclosed by two indistinct crenulated grey lines, the inner one interrupted in the cell by a white 'orbicular' dot; reniform stigma also white, partly edged with leaden grey; a marginal series of black dots: secondaries pale smoky brown, sericeous, slightly greyer towards outer margin; fringes of all the wings grey inclining to blackish, with whitly-brown basal line. Head and collar whitly brown, somewhat pearly; thorax flesh-reddish; abdomen whitly brown. Under surface sericeous whitly brown, the wings irrorated with greyish and with dusky marginal dots. Expanse of wings 25 millim.

Taru, 2nd February, 1897.

Unfortunately only one example of this very distinct species was obtained.

171. *HYPENA VULGATALIS*.

Hypena vulgatalis, Walker, Cat. Lep. Het. xvi. p. 82 (1858).

Samburu, 2nd November, 1896.

A single somewhat worn specimen, but new to us from Eastern Africa.

172. *OPHIUCHE MASURIALIS*.

Hypena masurialis, Guenée, Delt. et Pyral. p. 38 (1854).

Samburu, 8th & 12th November, 1896.

New to us from East Africa, though we have it from the North, South, and West.

173. *RHYNCHINA TARUENSIS*, sp. n.

Intermediate in character between *R. plusioides* and *R. antiqualis*, nearest to the latter, slightly larger and browner; a black or dark brown patch filling the interval between the black orbicular spot and the linear white 'reniform stigma,' and a second smaller black spot filling the angle of the inner angulated white transverse line; the costal and discal black spots of *R. antiqualis* almost or wholly obliterated; no irregular submarginal white line as in that species, but the external border faintly dusted with ashy-white scales; marginal line brown, scarcely discernible: in other respects the two species are almost identical. Expanse of wings 25-26 millim.

Taru, 27th & 29th November, 1st December, 1896.

174. *NODARIA EXTERNALIS*.

Nodaria externalis, Guenée, Delt. et Pyral. p. 64 (1854).

♀, between Voi and Ndi, 16th May, 1897.

175. SIMPLICIA INFLEXALIS.

Simplicia inflexalis, Guenée, Delt. et Pyral. p. 52 (1854).

Samburu, 31st October, 1896; between Voi and Ndi, 19th May, 1897.

New to us from East Africa.

One other Noctuid was obtained at Taru on December 1st, 1896, but it is headless and rubbed, so that its identification is impossible.

LYMANTRIIDÆ.

176. REDOA CROCIPES.

Cypra crocipes, Boisduval, Faune Ent. de Madag. p. 87, pl. 12. fig. 2.

♀, Maungu Inkubwa, 21st March, 1897.

The female is quite new to us; unfortunately only one example was obtained.

177. CROPERA TESTACEA.

Cropera testacea, Walker, Cat. Lep. Het. iv. p. 826 (1855).

♀ ♀, Mgana, 18th & 30th June, 1896; Voi, 7th May, 1897.

New to us from East Africa.

178. OGOA SIMPLEX.

Ogoa simplex, Walker, Cat. Lep. Het. vii. p. 1764 (1856).

♀, Taru, 19th December, 1896.

The type (the only other example which I have seen) is from Natal; this is therefore a welcome addition to the Museum collection.

179. LACIPA IMPUNCTA, sp. n. (Plate XXXII. fig. 6.)

Allied to *L. gracilis*: silvery white; primaries of the male with a pale buff spot and black dot near base of costa, and angular series of orange spots before the middle, of which the four lower ones are conspicuous, and a slightly sigmoidal (*geschwungen*¹) oblique series of seven spots across the disc; head, collar; and pterygodes pale buff; antennal pectinations testaceous; abdomen golden buff. Expanse of wings 23 millim.

The female, which I formerly supposed to be a variety of *L. gracilis*, was obtained in the Sabaki Valley by Dr. Gregory: it has no basi-costal spots on the primaries; the inner series of orange spots is reduced to two, and the outer series to six, all small; the body is white, with blackish anal tuft. Expanse of wings 35 millim.

♂, Mgana, 31st August, 1896.

The absence of all the black spots characteristic of *L. gracilis*, the nearer approach of the discal series of orange spots to the

¹ We have no English equivalent for this word, which exactly expresses the barely perceptible S-character of a line; 'sinuous' might mean more than S-shaped.

outer margin, the shorter fringe, and the deeper colouring of the male abdomen, readily distinguish this species from Hopffer's *L. gracilis*.

180. *LOPERA MONOSTICTA*, sp. n. (Plate XXXII. fig. 7.)

Nearest to *L. pallida*, Kirby, but the primaries creamy white, with a single small orange spot at the end of the cell; secondaries sericeous, snow-white; head ochreous; antennæ white, with testaceous pectinations; front of thorax, including the collar and anterior two-thirds of pterygodes, creamy white, remainder of body snow-white; under surface white; the basal half of costal margin of primaries buff; the collar below and the anterior coxæ ochreous. Expanse of wings 27 millim.

♂, Taru, 19th December, 1896.

181. *ILEMA ROBUSTA*?

Acyphas robusta, Walker, Cat. Lep. Het. iv. p. 799 (1855).

♂, Taru, 23rd November, 1896.

A fragment, much rubbed, apparently referable to this species.

ACLONOPHLEBIA, gen. nov.

Near to *Euproctis*, but totally dissimilar in aspect, altogether far less woolly; the head much more prominent, the palpi short, but very broadly fringed; pectinations of antennæ much coarser; legs much less hairy, the hind tibiæ with only the terminal pair of spurs, which are much more conical; the neuration very similar, but the subcostal veins of the secondaries (veins 6 and 7) not emitted from a footstalk, but near together from the anterior angle of the cell. Type *A. flavinotata*.

182. *ACLONOPHLEBIA FLAVINOTATA*, sp. n. (Plate XXXII. fig. 8.)

♀. Primaries above lilacine grey clouded with brown; a regular biangulated dark brown line across the middle of the wing, bordered broadly inside with whitish and outside with brownish; costal and interno-basal borders brownish; sometimes a black spot in the cell; a large diffused chrome-yellow patch beyond the lower angle of the cell, and a line of the same colour edging the central angulated line between its alternate angles; fringe pale stramineous indistinctly spotted with brownish; secondaries pale stramineous. Thorax grey; head, collar, and patagia clothed with testaceous hairs; antennæ grey, with darker pectinations; abdomen fulvous. Under surface stramineous, costal borders of wings ochraceous; primaries with a greyish spot at end of cell, indicating part of the central band of the upper surface; tarsi with greyish bands. Expanse of wings 27-32 millim.

Marago ya Fundi, 1st March; between Voi and Ndi, 2nd June, 1897.

Unfortunately only two examples, varying in size and also differing somewhat in pattern, were obtained.

HYP SID Æ.

183. EGYBOLIA VAILLANTINA.

Phalcena vaillantina, Stoll, Suppl. Cramer, Pap. Exot. v. p. 142, pl. xxxi. fig. 3.

Mgana, 30th August, 1896; Mombasa, 4th January, 1897.

It is not at all certain that this is a true Hypsid.

184. SOMMERIA CULTA.

Sommeria culta, Hübner, Exot. Schmett. Zutr. figs. 433, 434 (1818).

♂ ♀, Samburu, 1st & 5th November, 1896.

This is an interesting variety in which the normal white markings on the primaries are suffused with the ground-colour, giving them a very uniform character. That this is mere variation and has no specific value is evident from the fact that we have an example in the Museum in which the left primary is similarly suffused, whilst on the right primary many of the white markings are present.

S A T U R N I I D Æ.

185. USTA WALLENGRENII.

Saturnia wallengrenii, Felder, Wien. ent. Monatschr. iii. p. 323, pl. vi. fig. 2.

♀, Maungu Inkubwa, 29th March, 1897.

This is the only fairly perfect example I have ever seen—the species having hitherto only reached us from Dr. Gregory's collection, and so much rubbed and shattered as to be barely recognizable. Unless Felder had a very closely allied species, his figure is incorrect (probably made up from an injured specimen, as the outer black edging to the central belt of the primaries is deeply and conically incised between veins 2 and 3).

186. BUNÆA (THYELLA) ZAMBESIA.

Thyella zambesia, Felder, Reise der Nov., Lep. ii. pl. lxxxv. fig. 5 (1874).

♂, Taru, 30th March, 1897.

The larva of this moth (which is quite new to the Museum Collection) is said by Mr. Betton to have been common at Taru on December 10th; the present example pupated on December 17th, 1896, and emerged at the end of the following March. The larvæ and pupa, which Mr. Betton preserved, were unfortunately not sent to us with his collection; he refers to the former as "bottle of larvæ marked Taru, Nov. 23 to Dec. 15, 1896," and to the latter—"see matchbox marked 'M.'"

If Mr. Betton could breed a series of this Saturniid, I think it would be conclusively proved that *B. barcas* Maassen was only a variation; it certainly is extremely closely related, if distinct, and the fact that both occur at Zanzibar is very suspicious.

187. *HENUCHIA HANSALII*?

Ludia hansalii, Felder, Reise der Nov., Lep. ii. pl. lxxxix. fig. 1 (1874).

♀, Voi, 22nd April, 1897.

Felder's figure is either extremely bad, or this is a new species; it is very probable that the former is the correct explanation of the differences which exist between the two, and that the illustration was taken from a frayed and faded male. The species is quite new to the Museum, though nearly allied to the southern *H. delegorguei*, from which it differs chiefly in the trisinuated inner margin of the central belt of the primaries, its regularly undulated outer edging, the white margin of which is emphasized by a grey-mottled series of very indistinct markings across the disc. The female has the outer margins of the wings even more distinctly dentated than in that sex of *H. delegorguei*, but it is probable that this may not be the case in the male.

188. *GOODIA HOLLANDI*, sp. n. (Plate XXXIII. fig. 1.)

Allied to *G. nubilata*, but considerably smaller and paler: the male pale buff: the primaries clouded with fawn towards base of costa, the discoidal cell and centre of costa whitish, slightly mottled with lilacine grey (but most distinctly on costa); an ill-defined, irregular, transverse, dusky line across basal fourth, beyond which the inner border is partly white, flecked and edged with black almost to external angle; an oblique, ill-defined, sub-angulated, brown median band, just crossing the posterior angle of the discoidal cell and almost merging with a very broad golden-brown apical area crossed by an oblique slender dentate-sinuate black line, edged externally with whitish buff; costal border towards apex rose-tinted; the centre of external area occupied by a diffused lilacine greyish nebula, which commences in a dark grey cuneiform patch on outer margin towards apex; a curved blackish line on lower discocellular followed above the base of vein 4 by a buff-whitish spot: secondaries somewhat tawny within and below discoidal cell; a dusky line on discocellulars; an arched dentate-sinuate dusky line, blackish near inner margin, crossing the disc parallel to outer margin; costal and external areas pearly, tinted with pale rose and grey; inner or abdominal margin mottled with whitish and black. Head purplish brown, collar white, ochreous at sides, and brown-edged; thorax and base of abdomen pale buff; remainder of abdomen ruddy brown, excepting the anal tuft which is ochraceous; antennæ dark brown, with double divergent bipectinations fringed with buff-whitish pile. Under surface differing a good deal in detail from the upper surface, brown mottled and heavily clouded with lilacine greyish on basal half; body rosy brownish-purplish in front. Expanse of wings 58 millim.

♀. Smaller and altogether more ash-coloured than the male; the primaries less falcate, the secondaries narrower, less produced at anal angle, most of the markings obliterated, but the cell of the

primaries ashy whitish as well as the area below it. Expanse of wings 53 millim.

♂, Voi, 18th April, 1897; ♀, Yaru, from larva obtained 12th December, 1896, pupated 20th December, emerged 4th May, 1897.

The species is also related to *Lasioptila ansorgei* Kirby (= *Saturnia kuntzei* Dewitz), which must be referred to Dr. Holland's genus *Goodia*. Kirby's *L. pomona* is not congeneric with the latter; therefore if his generic name is retained it must take *L. pomona* as type, instead of *L. ansorgei*.

I have named this pretty little species after the learned author of the genus, to whom all students of African Lepidoptera owe a debt of gratitude for his admirable work.

EUPTEROTIDÆ.

TROTONOTUS, gen. nov.

Allied to *Gangarides*, but with the form and aspect of *Eutricha* (*Lasiocampide*): the primaries not falcate, the radial of the secondaries (vein 5) wanting, only indicated by a fold, which disappears when damped with benzine; the angles of the cell also almost parallel; veins 6 and 7 not stalked as in *Gangarides*; the neuriation of the primaries is practically the same in the two genera; the palpi are narrower, less densely fringed, the antennæ bipectinated almost to the tips; the abdomen much shorter and conical rather than truncated at the anal extremity, with expansive lateral tufts; the legs very hairy; middle and hind tibiæ with strong pointed terminal spurs, the hind tibiæ also with a second subterminal pair of spurs. Type *T. bettoni*.

189. TROTONOTUS BETTONI, sp. n. (Plate XXXIII. fig. 2.)

♂. Primaries above coffee-brown, faintly glossed here and there with glaucous; a rose-and-white tufted ochre-yellow spot below base of cell; an irregularly undulated, partly interrupted, internally blackish-edged yellow Σ -shaped band across the basal third, also a few scattered yellow spots near its inner edge; a small deep ochreous reniform stigma; a broad internally angulated and undulated, externally irregular and sinuated discal yellow belt, traversed by four parallel dentate-sinuate stripes of the ground-colour and bordered outside by a blackish stripe; an oblique increasing slaty-blackish streak from apex, continuous with four transverse patches of the same colour parallel to outer margin; fringe darker than the rest of the ground-colour and tipped with blackish: secondaries pale ruddy-chestnut, shading into bone-yellowish on basi-costal area; fringe tipped with snow-white. Thorax greyish chocolate, with the top of the head, two large subconfluent spots on the middle of the collar, and the dorsal portion of the thorax between the patagia bright brick-red; antennæ pale buff, with white basal tuft and golden-brown

pectinations; abdomen pale ruddy chestnut, more golden towards the base, and with pure white lateral and anal tufts. Under surface white; the wings slightly yellowish on costal area; the apical and external areas of all the wings minutely dusted with coffee-colour; the secondaries, excepting along abdominal border, purer white than the primaries; pectus buffish at the sides, the anterior legs bright coffee-coloured in front, the second pair slightly stained and the third pair irrorated with the same colour; venter more densely and finely irrorated. Expanse of wings 49 millim.

Mgana, 28th August, 1896.

It is unfortunate that Mr. Betton was only able to secure one male of this strikingly beautiful new form; the specimen, however, is in good condition and will be a most welcome addition to the Museum collection.

190. SABALIA PICARINA.

Sabalia picarina, Walker, Cat. Lep. Het. xxxii. p. 548 (1865).

Samburu, 13th November, 1896.

Unfortunately only one somewhat broken example was obtained; it is a species badly represented in the Museum collection, of which we should be glad to obtain good specimens.

SPHINGIDÆ.

191. LOPHOSTETHUS DEMOLINII.

Sphinx demolinii, Angas, Kaffirs Illustrated, pl. xxx. fig. 11 (1849).

♂, Taru, 29th November, 1896; ♀, Voi, 17th April, 1897.

192. POLYPTYCHUS GRAYII.

Smerinthus grayii, Walker, Cat. Lep. Het. viii. p. 249 (1856).

♀, Voi, pupa 6th May, emerged 12th May; ♀, Mbuyuni, 30th May, 1897.

We previously only possessed the male of this species, from Natal.

193. DIODOSIDA ROSEIPENNIS.

Diodosida roseipennis, Butler, Ann. & Mag. Nat. Hist. ser. 5, vol. x. p. 433 (1882).

♂♂, Maungu Inkubwa, 31st March; Voi, 7th May, 1897.

The male is new to the Museum, the type being a female from Delagoa Bay.

194. PROTOPARCE CONVULVULI.

Sphinx convulvuli, Linnæus, Syst. Nat. 1, ii. p. 789 (1766).

Voi, 7th May, 1897.

195. AELLOPUS HIRUNDO.

Macroglossa hirundo, Gerstæcker, Arch. Nat. xxxvii. p. 360

(1871); Von der Decken's Reisen in Ost-Africa, Gliederthiere, p. 375, pl. xv. fig. 7 (1873).

Maungu Inkubwa, 21st March, 1897.

NOTODONTIDÆ.

196. ANTHEUA SIMPLEX.

Antheua simplex, Walker, Cat. Lep. Het. iii. p. 687 (1855).

♀, Taru, 23rd November, 1896.

The female is quite new to us and is of considerable interest, as it clearly indicates that *A. cinerea* Walk. is the female of *A. spurcata* of the same author.

197. STAUROPUS DASYCHIROIDES, sp. n. (Plate XXXII. fig. 12.)

♀. Primaries pale lilacine ash-grey, orbicular and reniform spots buffish white, ill-defined; a vague oblique dusky stripe from costa just behind the orbicular spot, uniting below first median branch with an ill-defined, pale-buff-bordered, undulated, arched post-median dusky line; beyond the latter three almost parallel diffused stripes, which form an imperfect widely zigzag inner limitation to a slightly paler external border; costa crossed beyond the middle by three or four short dusky bars: secondaries semitransparent white, with sordid costal border and moderately broad smoky-brown outer border; fringe ashy white: antennæ rosy cupreous, with ferruginous pectinations; thorax coloured like the primaries, the patagia slightly brownish; abdomen pale brownish ash. Primaries below pale lilacine ash-coloured, with vague whitish orbicular and reniform spots, between which runs a grey oblique streak from the costa; a faint trace of a postmedian stripe commencing in an oblique blackish costal dash, three blackish subapical costal spots, below which a broad smoky submarginal belt commences and runs to external angle; outer border pale lilacine ash-grey; interno-basal area white: secondaries as above: pectus ashy; legs somewhat fuliginous; venter sordid white. Expanse of wings 53 millim.

Maziwa Mitatu, 27th March, 1897.

This curious species has the neuration of *Stauropus*, but does not nearly resemble any form known to me.

GEOMETRIDÆ.

198. GONODELA SUFFLATA.

Macaria sufflata, Guenée, Phal. ii. p. 88, pl. xvii. fig. 8.

Between Voi and Ndi, 3rd & 4th June, 1897.

New to the Museum from East Africa, though we have it from the extreme south and from Abyssinia.

199. CÆNINA AURIVENA, sp. n.

Cænina flavivena Warren, MS.

♀. Primaries formed as in *C. pæciliaria*, pale greyish stone-

brown; the discoidal cell and a streak beyond it as well as the internal area mottled with cream-whitish, and the whole surface irrorated with blackish dots; a dusky almost falciform postmedian stripe; external angle mottled along inner margin with ferruginous; fringe white, varied with greyish brown at base: secondaries with deeply but widely inarched costa; outer margin produced into an acute point at extremity of first subcostal branch and very slightly sinuated between the apex and this point; remainder of outer margin slightly inarched, and very slightly sinuated to the so-called 'third median branch,' otherwise very regular; costal half coloured like the primaries, internal half almost to submedian vein suffused with coffee-brown, ferruginous at anal angle; a triangular yellow patch edged and intersected by ferruginous lines at base of median veins, and a short tapering white bar (in continuation of the yellow patch) across the end of the cell; abdominal area creamy white varying to silvery white; fringe white; the surface of the wing irrorated with blackish dots like that of the primaries. Head and palpi orange; antennæ cream-white; remainder of body above coloured like the primaries. Under surface of wings paler than above, mottled with deeper grey and speckled with black; the primaries with a longitudinal streak beyond the cell, a spot at base of median interspace and the interno-basal three-fifths creamy white grey-mottled; a subapical diffused patch, a patch below the centre of the disc, a very irregular patch at external angle, and a portion of the veins from the median backwards orange-tawny: secondaries with the abdominal half white, the costal half blotched and veined with orange-tawny; a white bar beyond the discoidal cell as above; outer margin grey varied with orange-tawny; fringe white: body below pale greyish brown, almost white on venter; legs varied with ferruginous. Expanse of wings 34 to 37 millim.

Samburu, 3rd November, 1896; Mbuyuni, 29th May, 1897.

We have males in the Museum from Ambriz and Accra; they show a tawny or brown-edged spot at the base of the median branches of the primaries above, more distinctly than in the female (where it only appears like an excrescence of the discoidal streak); the median vein and base of the submedian vein in the example from Ambriz are also yellowish (which doubtless suggested Warren's unsatisfactory name for the species). The darker portion of the secondaries in specimens from Accra is also darker in both sexes than in the male from Angola, but this is doubtless a variable character; the pectinations of the antennæ in male examples are pale orange.

The veins on the under surface of the primaries being partly orange-tawny, I have modified the manuscript name proposed by Warren.

200. A Boarmian form too much injured for identification, being not only faded and broken but a female.

Voi, 16th April, 1897.

HAMEOPIS, gen. nov.

Apparently nearer to *Zamacra* than to any other Geometrid genus, though differing entirely in neuration, in body clothing, in character of legs and palpi. Wings broader, shorter, and utterly dissimilar in character: primaries with veins 8 and 9 out of 7, stalked; 10 and 11 closely approximated, stalked at base: secondaries with all the veins separate excepting 7 and 8, which coalesce close to base, separating again before middle of cell; veins 3 and 7 both emitted from cell before the terminal angles. Antennæ with long straggling pectinations (as in *Zamacra*) to about four-fifths of the distance from their base, terminal fifth serrated; palpi small, porrected, smooth; thorax coarsely scaled, but not hairy; frontal process prominent, subquadrate, with bare Λ -shaped ridge running between the antennæ to back of head and deep facial depression; legs smooth; hind tibiæ with median spurs emitted close behind the terminal pair. Type *H. rudicornis*.

201. HAMEOPIS RUDICORNIS, sp. n. (Plate XXXII. fig. 13.)

Wings above sericeous white; primaries irregularly speckled all over with grey and blackish, a mottled subbasal band angulated at median vein, a reversed oblique costal spot just beyond middle, an oblique discal band forked on costa, and a partial outer border of the same colours, the blackish parts being costal: secondaries with a few scattered dark grey dots chiefly on the veins, indicating a discal transverse line; an apical patch and some scattered clusters of dots representing an external border. Head and thorax white, the horny shovel-shaped process and forked dorsal ridge on the head deep chestnut; shaft of antennæ dark smoke-grey, white barred with dark grey at base, pectinations pale brownish grey; thorax white, patagia alternately spotted and transversely barred with black, metathorax similarly marked; abdomen golden testaceous, whitish at the sides and at anal extremity, with dorsal dusky spots. Under surface white: wings paler in markings but otherwise as above; tibiæ banded in front with grey, tarsi black above. Expanse of wings 42 millim.

♂, Taru, 1st December, 1896.

202. HÆMATORITHRA RUBRIFASCIATA.

♂. *Hæmatorithra rubrifasciata*, Butler, Ann. & Mag. Nat. Hist. ser. 6, vol. xviii. p. 162 (1896).

♀, Mgana, 4th August, 1896.

This is the first female I have seen of *H. rubrifasciata*; the species would seem to be rare, Mr. Crawshay having only obtained two males during his sojourn in Nyasaland.

203. PROBLEPSIS VESTALIS.

Argyris vestalis, Butler, Ann. & Mag. Nat. Hist. ser. 4, vol. xvi. p. 419 (1875).

Taru, 19th December, 1896.

LASIOCAMPIDÆ.

204. HETEROPACHA sp.

A single female practically agreeing in structure and general appearance with the Texan *H. rileyana*, but too much worn for the pattern to be critically compared.

♀, between Voi and Ndi, 2nd June, 1897.

The specimen is an interesting addition, in spite of its poor condition, on account of its evident close affinity to a New World species.

205. CHILENA PROMPTA.

Lasiocampa prompta, Walker, Cat. Lep. Het. vi. p. 1437 (1855).
Voi, 22nd & 29th April, 1897.

New to the Museum from Eastern Africa.

206. CHILENA DONALDSONI.

Chilena donaldsoni, Holland, Through Unknown African Countries, pp. 413 & 420, fig. 8 (1897).

Samburu, 7th November; Taru, 29th November, 1896; Marago ya Fundi, 1st March; between Voi and Ndi, 18th May, 1897.

Fresh examples are darker coloured than the typical form (which was evidently somewhat faded); the silvery white marking on the primaries also sometimes is continued back completely to the base, though the basal half is less purely white than the permanent marking. *C. donaldsoni* is new to the Museum collection.

207. LEBEDA KÖLLIKERII.

Lasiocampa köllikerii, Dewitz, Verhandl. kais. Leop.-Carol. Deutsch. Akad. Naturf. vol. xlii. p. 78, pl. i. fig. 15 (1881).

♀, Maziwa Mitatu, 18th March, 1897.

The female is quite new to the Museum: structurally it perfectly agrees with *Lebeda nobilis*. A single male from Delagoa Bay was received in 1893, but is so much more yellow and altogether brighter in colour than the female that it was not recognized as Dewitz's species; it also differs in having the body above glistening golden buff, with a large black dorsal patch extending from the base to the anal segment.

LIMACODIDÆ.

208. SCOTINOCYROA INCONSEQUENS.

Scotinocyroa inconsequens, Butler, P. Z. S. 1896, p. 845.

Maziwa Mitatu, 24th March, 1897.

A single worn and very dirty male specimen, which must, I think, be referable to this species, but differs in having a pale buff patch with reddish centre at external angle of primaries; otherwise it agrees in pattern with the type: it is interesting as a variety.

Scotinocyroa is very closely related to *Zinara*, Walk.

209. *OMOCENA SYRTIS* ?

♂. *Miresa syrtis*, Schaus & Clements, Coll. Sierra Leone Lep. p. 28, pl. ii. fig. 3 (1893).

♀, Voi, 19th September, 1897.

The lines across the primaries approximate on costa and diverge more widely on inner margin than in the figure of the male; but variations of this nature are so common, that I dare not venture to assume their importance in the present instance.

210. *GAVARA VELUTINA*.

♂. *Gavara velutina*, Walker, Cat. Lep. Het. xii. p. 771 (1857).

♀, Maungu Inkubwa, 20th March, 1897.

New to us from E. Africa. Walker placed it in the *Noctuidæ*, just in front of the *Acontiinæ*, to which (of course) it has no affinity.

211. *NIPHADOLEPIS AURICINCTA*, sp. n. (Plate XXXII. fig. 9.)

Sericeous snow-white; primaries with faint traces of buff (possibly the indications of a subbasal stripe) near the base; two buff central stripes, oblique and tolerably wide apart from costa to median vein, thence rather closer together and undulated to inner margin; a buff discocellular lunule joining the outer stripe; an abbreviated buff submarginal stripe towards external angle; three black marginal dots at apex and one near to external angle: secondaries with narrow diffused dusky border: collar and patagia stained with buff; abdomen with bright golden-orange hind margins to the segments. Under surface sericeous snow-white, the primaries with sordid buffish suffusion on costal half; all the wings with two blackish marginal dots at apex; anterior legs banded with olive-brown. Expanse of wings 24 millim.

Taru, 29th November, 1896.

Niphadolepis approaches *Gavara* in structure, the antennæ and palpi being similar and the venation not very greatly differing.

212. *PARYPHANTA BISECTA*, sp. n. (Plate XXXII. fig. 10.)

Nearly allied to *P. fimbriata*: smoky grey, the primaries considerably darker than the secondaries and divided through the middle by a narrow oblique faintly angulated belt, white internally, flesh-tinted externally; a pale submarginal line; fringe with a buffish basal line and pale tips: secondaries bone-whitish towards base; fringe paler than in primaries, but similarly coloured: head pale buffish, antennæ and palpi pale golden ochreous; thorax whity brown, with dusky central transverse belt and posterior margin; abdomen golden-testaceous, with sericeous ashy dorsal transverse bars: under surface pale sandy brownish; primaries sericeous greyish shading to bronze-brown. Expanse of wings 17 millim.

♂, Samburu, 14th November, 1896.

Karsch describes his species as having the primaries grey, densely covered with brown dots; if examined under a platyscopic lens, my species might be described as pale grey densely covered with blackish dots.

LEMBOPTERIS, gen. nov.

In outline approaching *Tortricidia*, but in coloration and structure perhaps nearer to *Nymphadolepis*; the antennæ and palpi smooth, the former submoniliform and feebly setulose from before the middle to the distal extremities; hind tibiæ with very long spurs: primaries with the costal margin long, slightly arched; outer margin very oblique, forming a regular curve with the inner margin which is much arched; veins 7, 8, and 9 stalked: secondaries ovate; veins 3 and 4 from same point; discocellulars deeply inangled; veins 6 and 7 with a short footstalk. Type *L. puella*.

213. LEMBOPTERIS PUELLA, sp. n. (Plate XXXII. fig. 11.)

Primaries above sericeous snow-white; costal margin narrowly ochreous; two black dots at apex and two on the disc, of which one is below vein 2 and the other (which is not always present) below vein 6: secondaries pale golden stramineous, sericeous, with one dusky marginal dot near apex; fringe white-tipped: head and thorax snow-white; antennæ and palpi golden stramineous; abdomen stramineous, becoming white at base and with olivaceous transverse dorsal bars. Primaries below stramineous, finely dusted with greyish; fringe white; two blackish apical dots: secondaries sericeous white, almost silvery, costa washed with stramineous; extreme margin indicated by an extremely slender dusky line; a black subapical dot: body below silvery white, the anterior legs and the tarsi and spurs of the remaining legs golden stramineous; venter slightly tinted with this colour. Expanse of wings 21 millim.

Samburu, 7th November, 1896.

Two somewhat imperfect examples were obtained; apart from the outline of the primaries, the long slender legs and the great length of the median and terminal spurs on the hind pair are very characteristic.

ARBELIDÆ.

214. ARBELA ALBONOTATA, sp. n.

♂. Primaries above ash-grey, varying to whity brown at base, on costa, at external angle, and more or less on inner margin, and with two longitudinal diffused streaks of buffish and chestnut, one short beyond the cell, the other long below the median vein; veins and numerous black-edged transverse striæ sordid white; six pure white spots, one fairly large at end of cell, one small beyond it near outer margin; the other four are within the interno-median area, each placed upon a transverse stria, the first two small, the last two large and forming a triangle with the spot first mentioned: secondaries sericeous white, veins and margins brownish: antennæ castaneous, the shaft covered with glistening silvery scales; thorax buffish, the borders of all the divisions washed with chestnut and

edged with blue-black scales; abdomen clothed with long glistening white hair, the anal extremity with brown-tipped spatulate hair-scales; a large dorsal tuft tipped with blue-black near the base; remaining segments with transverse blue-black bars. Under surface white; markings of upper surface indicated in smoky brownish; secondaries with indications of similar markings on costa and (more vaguely) beyond the middle: body stained in the middle with chestnut brownish; front of head brown; two anterior pairs of legs clothed with brown and blue-black tipped bristles; hind pair less varied in colouring. Expanse of wings 25 to 31 millim.

♂♂, Maungu Inkubwa, 2nd April; Mbuyuni Hill, 31st July and 3rd August, 1897.

The example first obtained is somewhat shattered and worn; it represents the greatest expanse of wing and is the palest specimen of the three.

At first I imagined that this species might be the male of Karsch's *Pettigramma spiculata*; but a careful study of his description has satisfied me that his insect is the female of Walker's *Salayena transversa*, from Sierra Leone. *Salayena* differs chiefly from *Arbela* in the upright hair on the anal segment instead of spatulate hair-scales.

ZYGÆNIDÆ.

215. ARNIOCERA CHRYSOSTICTA, sp. n. (Plate XXXIII. fig. 3.)

Allied to *A. auriguttata* (*A. melanopyga* Wallgr.). Wings black, shot with blue; primaries with purplish blue almost to outer margin, where it shades into bright Prussian blue; costa densely irrorated with metallic emerald-green; five golden-ochreous spots as follows—one small, across the cell near its extremity, a larger oval one beyond the cell, one smaller (rounded) between veins 2 and 3, one large at centre of interno-median interspace, and one equally large, subtriangular, very metallic, crossed by vein 1 towards the base: secondaries shot with Antwerp blue, purplish on the fringe. Body black; vertex of head and palpi carmine-red; antennæ shining black; thorax slightly sprinkled with metallic green scales; patagia brilliantly brassy green; metathorax and base of abdomen greenish steel-blue; two terminal segments of abdomen ultramarine-blue, with black anal tuft. Wings below more brightly shot with blue than above, but the submedian golden-ochreous spots partially obliterated; the three others nearly as above. Body below black, the venter brilliantly glossed with steel-blue; anterior legs black externally, but clothed internally with short bright ochreous hair; femora of second pair purplish black, ochreous in front; the tibiæ orange-vermilion externally, clothed internally with long carmine hair; tarsi black; posterior femora purplish black; tibiæ vermilion-red, tipped with blue-black and with a long pencil of creamy-white hair extending to the basal third of the black tarsi. Expanse of wings 26 millim.

Samburu, 4th November, 1896.

Unfortunately only one slightly damaged example of this beautiful species was obtained¹.

216. ARNIOCERA CYANOXANTHA. (Plate XXXIII. fig. 5.)

♀. *Zygana cyanoxantha*, Mabille, Ann. Soc. Ent. Belg. 1893, p. 57; Mabille and Vuillot, Novit. Lep. fasc. xii. p. 151, pl. xxi. fig. 6. Samburu, 10th November, 1896.

One spotted male differs from Mabille's figure in the loss of the orange spot below the subapical one; the other examples have all the spots brilliant crimson instead of orange: the name for the species is therefore not very characteristic. The specimens are not in specially good condition, so I hope Mr. Betton will obtain others.

217. ARNIOCERA IMPERIALIS, sp. n. (Plate XXXIII. fig. 6.)

♂. Primaries above shining Prussian green, changing to blue at outer margin, five black-edged carmine spots (the two central ones sometimes confluent, forming a transverse band) as in *A. cyanoxantha*, fringe purple flecked with copper: secondaries with the basicostral half bright rose-colour, tinged with orange at base; outer half bright Antwerp blue, changing to purple on the fringe; an ill-defined subapical cluster of rosy scales: thorax glittering steely green, yellowish on centre of dorsum; sides of face purple; palpi carmine; sides of collar and inner border of patagia crimson; metathorax with sides and hind margin orange; abdomen orange-vermilion, tinted with carmine at the sides, basal segment greenish black. Primaries below bright blue, spots as above, but more vermilion; base of cell varied with golden testaceous: secondaries rose-red, with a basi-costal dash and a longitudinal costal streak blue; a squamose blackish streak from end of cell to extremity of vein 1; fringe greyish coppery at apex: body below blue-black; anterior coxæ orange-vermilion; a golden line along inner edge of tibiæ; middle tibiæ carmine with black tips; posterior tibiæ with long cream-whitish pencil of hairs. Expanse of wings 32 millim.

Samburu, 10th November, 1896.

Two tolerably good examples of this lovely moth were obtained.

¹ The following beautiful new species was presented to the Museum by Dr. Edward A. Heath:—

ARNIOCERA ERICATA, sp. n. (Plate XXXIII. fig. 4.)

Primaries glossy greenish black; a broad irregular subbasal belt, a bilobed oblique postmedian abbreviated band, and a large ovate oblique subapical patch scarlet: secondaries with ochreous costal area, otherwise the basal half vermilion, with an irregular submedian basal blue-black patch; external half blue-black, throwing a long inner process up vein 1, enclosing a large scarlet subapical spot, and slightly sprinkled with scarlet along outer margin: thorax greenish black; abdomen scarlet, transversely banded with indigo-blackish; antennæ and palpi black; anterior legs greenish black; tibiæ slightly testaceous internally, tarsi with reddish short bristles; middle legs with the femora greenish black, slightly chestnut below (possibly owing to abrasion); tibiæ clothed with scarlet hair, with tip and spurs black; tarsi brown; hind legs a good deal rubbed, but apparently similar to the middle pair: wings below nearly as above, but the primaries broadly orange at the base. Expanse of wings 34 millim.

British East Africa (*Heath*).

218. *ARNIOCERA STERNECKI*. (Plate XXXIII. fig. 7.)

Arichalca sternecki, Rogenhofer in Baumann's Usambara u. s. Nachbargebiete, p. 331 (1891).

Maungu Inkubwa, 21st March, 1897.

Rogenhofer describes his insect as having the abdomen and secondaries yellow; in Mr. Betton's specimens they are carmine. Either the type was a faded specimen or one of those orange-yellow variations common among the crimson-winged *Zygenida*. The species is quite new to us.

PYRALIDÆ.

219. *ANCYLOLOMIA CHRYSOGRAPHELLUS*.

Crambus chrysographellus, Kollar in Hügel's Kaschmir, p. 494. Taru, 27th November, 1896.

220. *BRIHASPA CHRYSOSTOMUS*.

Schoenobius chrysostomus, Zeller, Micr. Caffr. p. 68. Mgana, 1st & 9th August, 1896. New to the collection from East Africa.

221. *PATISSA* sp.

Close to *P. fulvosparsa*, but without the ochreous markings; it has lost both labial palpi and fringes, and may even be a very worn example of the Asiatic species: therefore I hesitate about giving it a name.

Samburu, 4th November, 1896.

222. *MACALLA* sp.

Maungu Inkubwa, 3rd April, 1897.

One shattered female was obtained, but, even if perfect, it would not be satisfactory to describe it without seeing the male, the antennal characters of that sex often differing in species of the same genus.

223. *LEPIDOGMA* sp.

Taru, 24th November, 1896.

One slightly damaged female; it was enclosed in the same envelope with a much worn and quite unrecognizable Noctuid (apparently a *Metachrostis*). It is of no use to describe this species without its male; it and the preceding are both new to the Museum series, and will probably be of service when the other sex comes to hand.

224. *ZITHA VARIANS*, sp. n. (Plate XXXIII. figs. 8, 9.)

Primaries vinaceous grey-brown or bright chestnut, with or without marginal dusky dots; a broad central belt, either more dusky or scarcely differing in tint from the ground-colour, but margined on both sides by more or less dentate-sinuate whitish stripes diverging on costal margin; the inner stripe more or less strongly inangulated below median vein, the outer stripe zigzag;

a whitish spot below base of cell; a series of white costal points between the two transverse stripes; a more or less prominent blackish reniform stigma; a whitish line at the base of the fringe: secondaries paler than primaries, crossed beyond the middle by a dusky bordered whitish line parallel to outer margin; a whitish line at base of fringe: body darker than ground-colour of wings. Under surface of wings paler and more uniform than above, reddish on costal and outer borders, whitish on internal area; a dusky median shade bounded by the outer whitish stripe of the primaries and the postmedian whitish stripe of the secondaries; inner whitish stripe of primaries obsolete; a blackish spot at the anterior angle of each discoidal cell; indistinct dusky marginal dots followed by the whitish line at base of fringe: body below somewhat darker and redder than the wings, the tibiæ and tarsi paler. Expanse of wings 23 to 25 millim.

Voi, 17th April; between Voi and Ndi, 4th June, 1897.

225. *PYCNARMON CRIBRATA*.

Phalæna cribrata, Fabricius, Ent. Syst. iii. 2, p. 215 (1794).

Mgana, 12th August, 1896.

New to us from East Africa; indeed, we previously only possessed one African example (from Sierra Leone).

226. *LYGROPIA AMYNTUSALIS*.

Botys amyntusalis, Walker, Cat. Lep. Het. xviii. p. 662 (1859).

Marago ya Fundi, 4th March, 1897.

The same observation applies to this as to the preceding species.

227. *SYNGAMIA ABRUPTALIS*.

Asopia? abruptalis, Walker, Cat. Lep. Het. xvii. p. 371 (1859).

Mgana, 5th August, 1896.

New to the Museum from Eastern Africa, though we have it from Accra.

228. *GLYPHODES STENOCRASPIS*, sp. n. (Plate XXXIII. fig. 10.)

Wings pearly semitransparent white; primaries with narrow gilded brown costal border, very narrow darker brown outer border excised below vein 8; fringe greyish brown, with slender white basal line; a small black spot at end of cell: secondaries with narrow dark brown border not reaching anal angle, fringe as in primaries: body snow-white, the patagia silvery, the collar slightly stained yellowish, front of forehead brownish testaceous; anal tuft black: wings below nearly as above, but the borders paler, costal border confined to the extreme margin and a stain towards apex. Expanse of wings 29 millim.

Mombasa, 4th January, 1897.

Nearest to the Western *G. elealis* Walk. (of which *Phakellura peridromella* Mab. is a synonym), but with the brown borders to the wings considerably narrower; the excision of the outer border at apex of primaries also allies this species to *G. albifuscalis* Hamps.

229. GLYPHODES SINUATA.

Phalæna sinuata, Fabricius, Ent. Syst. iii. 2, p. 208 (1793).

Voi, 1st May, 1897.

230. LEPYRODES GEOMETRALIS.

Lepyrodes geometralis, Guenée, Delt. et Pyral. p. 278.

British E. Africa (no exact locality or date on envelope).

New to the Museum from Eastern Africa; we have it from Accra.

231. LEPYRODES CAPENSIS.

Lepyrodes capensis, Walker, Cat. Lep. Het. xxxiv. p. 1344 (1865).

Mgana, 1st August, 1896.

New to us from Eastern Africa.

232. ZEBRONIA PHENICE.

Phalæna phenice, Cramer, Pap. Exot. iv. p. 185, pl. cccclxxxii. G (1782).

Mgana, 1st August, 1896; Mombasa, 4th January, 1897.

New to us from the Eastern coast; we have it from Uganda.

TINEIDÆ.

233. MICROCOSSUS BETTONI, sp. n.

Nearest to *M. mackwoodi*: sordid sericeous white; primaries transversely reticulated with brown lines, some of which are dotted with black scales; the reticulated lines are coarser on costal border, especially towards the base and the apex, and form the boundaries of slightly brownish quadrate spots, the best defined of these spots is placed on the costa just above the end of the cell; antennæ bronze-brown, sericeous, with dull testaceous pectinations in the male: under surface brownish; primaries with ill-defined darker brown patches. Expanse of wings 25 to 30 millim.

♂ ♀, Samburu, 31st October, 1896.

Only one pair of this obscure little moth was obtained, unfortunately not in perfect condition.

234. A Micro-Lepidopteron of doubtful genus.

Taru, 16th December, 1896; Voi, 2nd May, 1897.

A very beautiful little moth quite new to the Museum: the primaries blue-green and glistening, the secondaries sericeous purple; anterior half of body black, posterior half golden ochreous. Not having paid much attention to the *Tineidæ* I will not pretend to decide where this insect should be placed; it has antennæ which remind one of typical *Zygænidæ*, and, so far as I remember, are only approached by *Exodomorpha* or *Eretmocera*.

The following new genus, structurally, should be an Arctian, and must therefore be placed in the *Arctiidæ*, but it has much more nearly the aspect of a Noctuid of the *Plusia* group of genera; it reminds one a little of *Culasta* and (in style of coloration) of *Rhynchina*.

METACULASTA, gen. nov.

Primaries elongate, subtriangular; vein 2 remote from 3; 3, 4, and 5 separate but emitted near together; 6 from upper angle of cell, 7 from centre of postdiscoidal areole, 8 and 9 stalked, out of 10, which forms front of areole; 11 emitted well before end of cell: secondaries with costa slightly angular at centre; veins 2 to 6 as in primaries, 7 and 8 anastomosed to near end of cell: thorax broad, flattened above; head rather wide; antennæ smooth, palpi directed obliquely upwards; hind tibiæ with two pairs of spurs, inner spurs very long. Type *M. dives*.

235. METACULASTA DIVES, sp. n.

♀. Primaries above golden testaceous, longitudinally indistinctly streaked with greyish and flecked with blackish near the borders; a black dot at upper angle of cell; a very oblique shining silver streak towards the base, just entering the discoidal cell and not extending below vein 1; a second slightly-waved arched oblique streak commencing at about the basal third of inner margin (where it is indistinct) and extending to apex; a pale diffused flesh-tinted band runs above the latter, almost filling the interval between the two silver streaks on the lower half of the wing; fringe with a pale basal line: secondaries pearl-white, slightly buffish at costal and outer margins: thorax ash-greyish; abdomen whity brown, nearly white. Primaries below whity brown, showing traces of the upper surface markings through the wing: body below white; tarsi slightly brownish underneath. Expanse of wings 33 millim.

Voi, 11th July, 1897.

EXPLANATION OF THE PLATES.

PLATE XXXII.

- Fig. 1. *Pyrgus bettoni*, p. 415.
 2. *Baoris auritinctus*, p. 416.
 3. *Aloa bivittata*, p. 417.
 4. *Lacydes gracilis*, p. 417.
 5. *Bettonia ferruginea*, p. 418.
 6. *Lacipa impuncta*, p. 427.
 7. *Lopera monosticta*, p. 428.
 8. *Aclonophlebia flavinotata*, p. 428.
 9. *Niphadolepis auricincta*, p. 437.
 10. *Paryphanta bisecta*, p. 437.
 11. *Lembopteris puella*, p. 438.
 12. *Stauropus dasychiroides*, p. 433.
 13. *Hameopsis rudicornis*, p. 435.

PLATE XXXIII.

- Fig. 1. *Goodia hollandi*, p. 430.
 2. *Trotonotus bettoni*, p. 431.
 3. *Arniocera chrysosticta*, p. 439.
 4. „ *ericata*, p. 440.
 5. „ *cyanoxantha*, var., p. 440.
 6. „ *imperialis*, p. 440.
 7. „ *sternecki*, var., p. 441.
 8. 9. *Zitha varians*, p. 441.
 10. *Glyphodes stenocraspis*, p. 442.



6



1



7

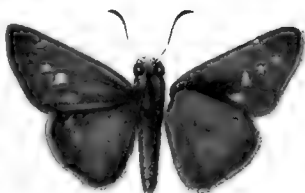

2



4



9



3



10



11



4

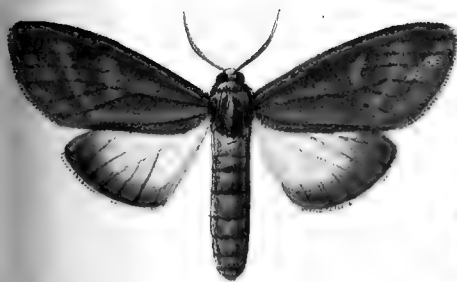

12



5

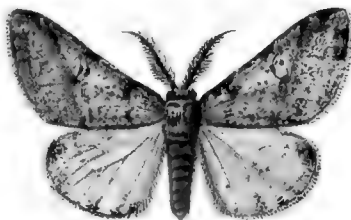

13

E. C. Knight ad nat lith.

West, Newman chromo





E. C. Knight ad nat., lith.

West, Newman chromo.



3. On some Earthworms from British India.

By SOPHIE M. FEDARB.¹

[Received April 19, 1898.]

These worms, which have been collected at Dehra Dun in the N.W. Provinces, have been sent from the Calcutta Museum, through the instrumentality of Mr. F. Finn, to Mr. Beddard. He has with great kindness allowed me to investigate them at his laboratory at the Society's Gardens.

This collection contains specimens of:—

- a. *Typhæus orientalis* Beddard.
- b. *Perichaeta cupulifera*, sp. nov.
- c. *Perichaeta crescentica*, sp. nov.
- d. *Dichogaster parvus*, sp. nov.

TYPHÆUS ORIENTALIS F. E. B.

Typhæus orientalis Beddard, Ann. Mag. Nat. Hist., Oct. 1893, p. 219.

This species has been previously found near Calcutta, and the present specimen, though not coming from the same neighbourhood, closely resembles the description of that one. There are, however, minor differences.

(1) The *dimensions* of the Dehra worm are:—length 158 mm.; breadth 5 mm.; number of segments 192; while the Calcutta worm measures 250 mm.

(2) The *papillæ* are not so well developed in the present specimen. There are none between segments xiii.–xv., though they are found between segments xv. and xvii. and between xviii. and xx.

Youth or a more delicate constitution might account for both the above.

The absence of the outer pair of setæ from the clitellar segments, and the markings on the penial setæ, agree with the previous description.

The five pairs of intestinal glands occur in segments xci.–xcv.

PERICHAETA CUPULIFERA, sp. nov.

Length 91 mm.; breadth 4 mm.; number of segments 93.

External Characters.

The *clitellum* occupies the whole of segments xiv.–xvi. It is rather darker in colour than the rest of the body, and bears lines of setæ on the three segments.

The *papillæ* of this worm are rather distinctive and occur in two localities:

(a) *Near the spermathecal pores.* In five cases there is a pair of cup-shaped papillæ at the edge of the segment in a line with the

¹ Communicated by F. E. BEDDARD, F.Z.S.

pores between segments vi./vii. In three instances also a similar papilla exists on one side only, while in another worm they are entirely absent. One of these specimens has in addition two median papillæ of like form on segments vii. and viii., placed in front of the seta line (*cf.* the median papillæ in *P. morrisi*)¹.

(b) *Near the male pores.* These are found on segments xviii. and xix., and are more or less complicated and variable. Some of the younger worms have only a lenticular patch where in the older ones is a circular cup-shaped papilla on an ill-defined excrescence. Doubtless the patch is an incipient papilla. One of the most complicated arrangements is as follows:—

Segment xviii. is divided into three rings; the central and widest bears the setæ and the male pores. These last are placed on excrescences which thin away to the line of setæ ventrally and dorsally. Either side of each pore, *i. e.* anterior and posterior to it, are two cup-shaped papillæ (fig. 1) pressed one against the other.

Fig. 1.

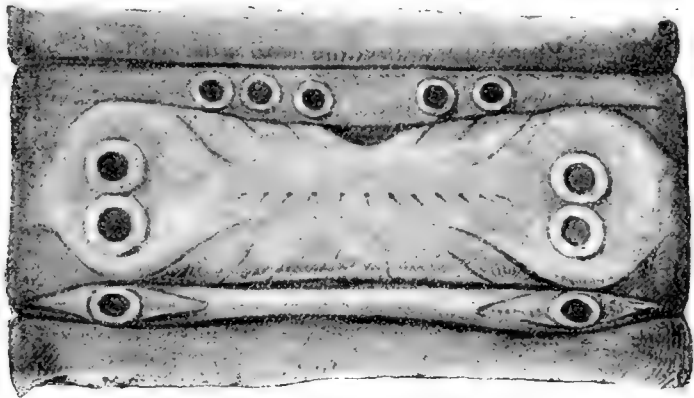

Ventral surface of xviii segment of *Perichæta cupulifera*, showing the cup-shaped papillæ.

The anterior ring bears five papillæ, three on the right side, two on the left, placed in a row with a slight ventral gap. The posterior ring has two papillæ, one on each side, in a line with the male pore. In some other specimens this last pair are intersegmental in position, or else on the ninth segment. One had also a median papilla on this segment.

Internal Features.

The *gizzard*, which is nearly globular, lies in segments viii. and ix., the septum dividing them being absent as usual, and that between segments ix./x. being reduced to threads.

The last pair of *hearts* is in segment xiii. They are very well developed.

¹ Beddard, P. Z. S. 1892, p. 166.

The *intestine* begins in segment xv. in the ordinary way, but it narrows again in xvii., xviii., and xix., and then increases to its full size in xx. This is possibly due to the size of the spermiducal glands, and to the existence of a group of little white glands, which would limit the space left for the intestine.

There are large *sperm-sacs* in segments xi. and xii., the foremost pair of which extend into segment x. ventrally.

The *spermiducal glands* lie in segments xviii. (or xvii.)-xx. They have no muscular sacs, and have a straight duct. The lobulation is not at all deep. As before mentioned, each side has a group of little white glands evidently connected with the papillæ.

The two pairs of *spermathece* are in segments vi. and vii. The pouch is an oval sac, with a duct of about the same length—shorter in the specimen with median papillæ in this region. The diverticulum is swollen at its extremity, and is the length of the duct and pouch together.

This worm comes very close to *P. barbadensis*¹, but the papillæ at the male pores are most distinctly different. It also approaches *P. amazonica*², but that worm has no clitellar setæ.

PERICHÆTA CRESCENTICA, sp. nov.

Out of the nineteen specimens of this species in the collection only one is mature.

External Characters.

Length 80 mm. ; breadth 4 mm. ; number of segments 101.

The *clitellum* takes in the whole of segments xiv.-xvi. It bears three rows of setæ equal in number to those on the other adjoining segments. These setæ are not in any way modified as in *P. houletti*³. They are precisely similar in form to those on the ordinary segments.

The *male pores* are separated by about 12 setæ. There are no papillæ at all, but the pores are tumid. The aperture itself is crescentic, with the horns turned outward; while its margins are crenated, suggestive that the muscular sac within is more or less eversible (cf. *P. capensis*)⁴.

Internal Features.

The *gizzard*, which is bell-shaped, occupies the viiiith and ixth segments.

The *intestine*, as usual, begins in segment xv., and bears *cæca* which originate at the anterior part of segment xxvii. and reach forward to segment xxiv.

There are *septal glands*, which very much increase in size behind the cæca.

¹ Beddard, P. Z. S. 1892, p. 167.

² Rosa, Atti R. Accad. Sci. Torino, 1894, p. 14.

³ Perrier, Nouv. Arch. Mus. 1872, p. 99.

⁴ Horst, Zool. Ergebn. Ost-Indien, p. 62.

The last *hearts* are in segment xiii.

The *sperm-sacs* in segments xi. and xii. are small, but possibly not fully developed.

The *spermiducal glands* are large, with digitate lobes, which extend from segment xvi. or xvii. to xx. The muscular sac occupies nearly the whole width of segment xviii., with the spirally-coiled duct lying on it.

The *spermathecae* (fig. 2), of which there are three pairs in segments vii., viii., and ix. respectively, are very interesting. Each one

Fig. 2.

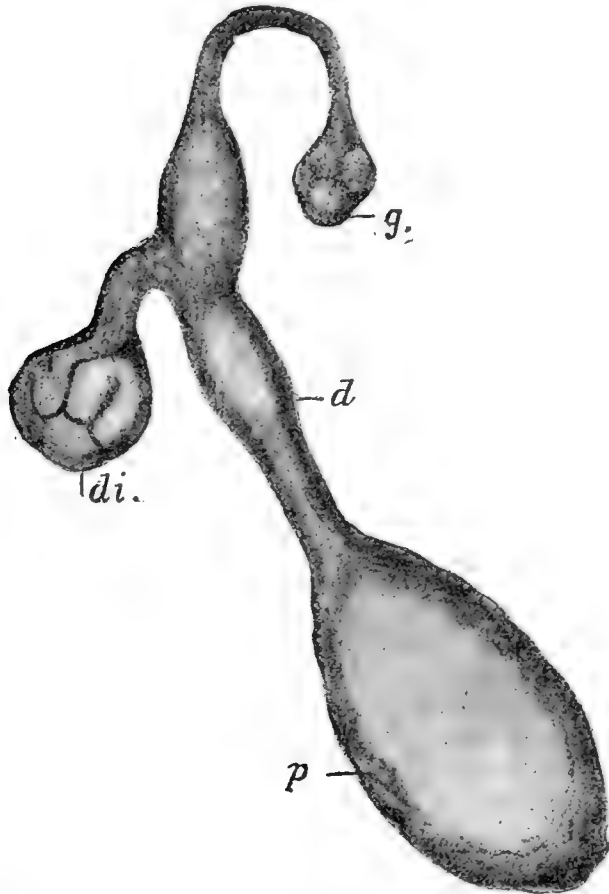

Spermatheca from viiith segment, right side, of *Pericheta crescentica*:
p, pouch; *d*, duct; *di*, diverticulum; *g*, gland.

consists of an oval pouch with a duct of the same length. The diverticulum is coiled up at the end into a little globular knot enclosed in a delicate skin. Attached to the junction of the diverticulum with the duct is a stalked white gland nearly equal in size to the diverticulum. This gland lies forward, while the diverticulum

points in the opposite direction. The junction itself, which is close to the pore, is enlarged. It will be remembered that *P. peguana*¹ has a similar diverticulum, and that *P. houletti* has one or two copulatory glands opening into the duct of the spermatheca.

This worm in many respects much resembles *P. houletti*, but as the clitellar setæ are not in any way modified, which is so very distinctive of that species, this can hardly be the same.

DICHOGASTER PARVUS, sp. nov.

Length 40 mm.; breadth 2 mm.; number of segments 132.

The setæ are in number 8 per segment. The two ventralmost on each side are most distinctly paired; while the two more dorsal setæ are as far from each other as one of them is from the outermost of the ventral pair. This greater distance is about twice that which separates the two setæ of the ventral pair.

The clitellum is rather short, only reaching from segment xiii. to xvii. On this last segment it is perfect dorsally, but it is discontinued ventrally, with a most distinct edge, to make room for the male pores. There is a kidney-shaped area where the female pores lie.

The spermathecal pores are small, circular, insignificant-looking openings just in front of, and exactly between, the ventral pair of setæ in segment viii.

The male pores are situated on ill-defined wrinkled papillæ, which approach each other in an oblique line anteriorly. The pore itself is a slit with puckered lips, following the same oblique line.

The dorsal pores begin between segments xi./xii.

Internal Features.

This worm has diffuse nephridia, but they are of considerable size.

There are two gizzards in segments v. and vi., the foremost being rather more globular than the other.

The calciferous glands are small, but exist in segments xi., xii., and xiii. Their free ends point towards the median dorsal line. The anterior pair are the largest.

In segment xi. are a pair of tongue-shaped sperm-sacs.

The spermiducal glands are tubular and bent in a zigzag manner. The duct, which is about the same width as the glandular portion, is comparatively stout. It is not provided with any penial setæ.

There is but one pair of spermathecae, and these lie in segment viii. They are tubular structures without any diverticula, rather inclined to be bulbous at the end. They lie twisted across each other and across the nerve-cord.

It will be seen from the above description that it does not

¹ Rosa, Ann. Mus. Civ. Genova, vol. x. (2a) 1890, p. 113.

exactly coincide with any genus of the Cryptodrilidæ. It comes nearest to *Dichogaster*¹. This genus was created by Mr. Beddard to include a Fijian worm. Dr. Michaelsen afterwards placed in the same genus some worms that differed in several points and necessitated the definition being altered. Mr. Beddard says²:—“It may be noted also that there is nothing in Michaelsen’s description which is opposed to uniting with his two species of *Dichogaster* my species of *Microdrilus*.” The definition to include these runs:—

“Setæ paired. Dorsal pores present. Clitellum xiii.–xx. (xxiii.). Male pores on xvii. Two gizzards; three pairs of calciferous glands. Nephridia diffuse. Spermiducal glands tubular.”

If it were justifiable to alter the definition so as to fit Dr. Michaelsen’s worms, surely it might be stretched a little more, viz., in the variable extent of the clitellum, so as to include the present species, which comes nearest to Dr. Michaelsen’s, *D. mimus*³.

4. On a new Genus and Species of Rodents of the Family *Anomaluridæ*, from West Africa. By W. E. DE WINTON, F.Z.S.

[Received May 11, 1898.]

(Plates XXXIV. & XXXV.)

The British Museum has lately received a collection of mammals from the Benito River in the north of French Congo. Among these is a specimen of a Rodent which is quite new to science. It belongs undoubtedly to the curious family *Anomaluridæ*, but, unlike either of the hitherto described genera which can in any way be compared to it, it has no flying-membranes. Mr. G. L. Bates has, therefore, materially added to our knowledge of this group, having already obtained the first examples of *Idiurus macrotis* lately described by Mr. Miller from specimens in the Washington Museum, and examples of *Anomalurus batesi* previously described by the present author.

I have to thank Sir William Flower, Director of the British Museum, for allowing me to work out the mammals obtained by Mr. Bates, and I feel particularly grateful to Mr. Oldfield Thomas for so willingly foregoing his right of describing this fine new form.

AËTHURUS, gen. nov.

Externally resembling *Anomalurus*, but without expanded flying-membranes; with tufts of modified hairs on the ankles. The facial portion of the skull and the proportions of the teeth much resem-

¹ Beddard, Q. J. M. S. vol. xxix. 1889, p. 251.

² Beddard, Mon. Olig., Oxford, 1895, p. 477.

³ Michaelsen, Arch. f. Nat. 1891, p. 202.

bling *Idiurus*, but differing from both the above-named genera in not having any supraorbital processes of the frontal bones.

ÆTHURUS GLIRINUS, sp. nov. (Plates XXXIV. & XXXV.)

The general appearance of the animal suggests a large *Graphiurus* with bushy black tail; or it may be compared to a small grey *Anomalurus* without flying-membranes. The fur is soft and dense; the entire upper surface of the body, head, and outer surface of the legs, and the base of the tail ash-grey; the lower surface and inner side of the legs lighter, or more silvery; the whole of the fur is plumbeous slate-coloured except the extreme tips, which are silvery. The colour is more pure dark grey than in any *Graphiurus*, there being almost an entire absence of drab in the colouring, and the fur agrees with *Anomalurus* and not with *Graphiurus*. The whiskers are strong and abundant, deep shining black, the longer hairs reaching to the shoulders; there are about five similar though shorter hairs standing out from the eyebrows. The tail, for a distance of about 30 millimetres from the base, is clothed above and below with soft fur like the body; on the lower side, beyond this, there is a pad of large scales exactly similar to those found in *Anomalurus*, about 35 millimetres in extent, composed of 13 scales. On the upper side of the tail, for nearly the same distance as that occupied by these large scales, only a few scattered hairs appear, barely hiding the rather coarse ordinary scales, but as the hair thickens the scaling becomes finer, and before the spot above the end of the lower scale-pad is reached the tail is covered with long black hair; from this point the tail is bushy, distichous, and squirrel-like, all the hairs shining black, and attaining the length of 45 millimetres or more towards the extremity.

In the present specimen the tail has been split and sewn up. There is a bare patch about the middle on one surface, probably caused by some former injury necessitating the splitting of the tail in the removal of the vertebræ, so that it may be only individual.

The ears are naked and dull black in the dry skin. Both the fore and hind feet are sparingly clothed with shining adpressed hairs; there are no coarse curved hairs at the base of the claws as in *Anomalurus*. On the outer side and in front of the ankles there are glandular swellings furnished with short, stiff, fusiform hairs (Plate XXXV. figs. 10-12) about 5 millimetres in length, curving downwards at the points, forming peculiar black frills or anklets. The palms, soles, and claws are pale in colour, the last-named not nearly so powerful as those of *Anomalurus*, especially those of the fore feet. The fore feet (Plate XXXV. fig. 8) are very slender, the fingers very long, and in their proportions one to another are unlike those of either of the allied genera; the thumb is entirely wanting, the 2nd and 5th fingers are subequal, shorter than the 3rd, the 4th being the longest. The hind feet (Plate XXXV. fig. 9) are more like those of *Anomalurus*; the hallux is, however, shorter, the end of the claw only reaching to the joint of the first and second phalanges of the second toe.

The general form of the skull (Plate XXXV. figs. 1-4) more nearly resembles that of *Idiurus* than *Anomalurus*, and in the proportion and form of both incisors and molars (Plate XXXV. figs. 6, 7) there is still nearer resemblance to the former. It is impossible at present to compare the skull directly with that of *Idiurus*, as the Museum does not contain a specimen of that genus; comparison will therefore be based upon the figures of *Idiurus macrotis* given by Mr. G. S. Miller, Proc. Biol. Soc. Washington, xii. p. 75, for March 1898.

The most striking differences are found in the palate, the zygomata, and the supraorbital region of the frontal bones; in these particulars the skull is also wholly unlike that of *Anomalurus*.

Taking these differences in the above order, in the animal under notice, in front of the molars the palatal aspect of the maxillæ is of uniform width, absolutely horizontal, with abrupt lateral edges; these straight lines are not found in the skull of any other rodent. The anterior (lower) root of the zygomatic process of the maxilla is set diagonally across the corner of that bone, springing abruptly from immediately behind the suture with the premaxilla, and is thus placed nearer to the incisors than to the molars (a character in which it appears to agree with *Idiurus*, and in a less degree resembling the form found in *Pedetes*); the process is narrow, solid, and rod-like, ascending and diverging to meet the malar, with which bone it forms an obtuse angle, and sending out only a very short spur-like process upon which the malar rests; it continues then only to form half, or the inner margin, of the frame of the anteorbital foramen; the malar sending out a long ascending process, which joins the lachrymal, forms the posterior portion of the upper root of the zygomatic arch, or the anterior wall of the orbital cavity.

The malar is of unusual depth; the lower edge is quite straight, forming an angle posteriorly. The squamosal process is unusually developed, extending about halfway along the upper side of the arch, and so forming the postorbital ascending angle, a character with which I can find no parallel.

The frontal bones are very unlike those of *Idiurus* or *Anomalurus* in the total absence of any projecting ridges or postorbital processes, agreeing in this respect with the *Myoovidæ*.

The auditory bullæ are very small. The back of the palate and the pterygoids throughout are very like those of *Anomalurus*; the ectopterygoids are absent or rudimentary as in the two allied genera. The palate is narrow and peculiarly uniform in width along its whole length; from the palatal to the incisive foramina there are two grooves forming a median rounded ridge along the centre of the palate. The external view of the incisive foramen (there is but one) is little more than a narrow slit; possibly the true formation is a still further development of the sinus or pit found in *Pedetes*, in which the foramina are placed; in any case this formation would probably only be the result of the deepening of the facial portion of the skull, to give strength in gnawing.

The molars in the present specimen are much worn, but there is no doubt they are of a very simple form, having a single enamel fold on the outer side only, dividing the tooth into two shallow oval cups, and thus would not differ greatly in pattern from the teeth of *Pedetes* except in the fact of their being brachydont instead of hypsodont.

The incisors are very large, being little inferior in antero-posterior depth to those of the large squirrels of the *Stangeri* group. The molar series are in parallel rows, the teeth very small and simple, as already stated; the first and last teeth of the series are about equal in size and little more than half the size of the two middle teeth, which are also about equal one to another in size. The teeth in the lower jaw, both the incisors and molars, bear the same relative proportions one to another.

The formation of the mandible (Plate XXXV. fig. 5) resembles that of *Idiurus*, as described by Mr. Miller, in the formation of a thickened bridge between the coronoid and condylar processes, with a thin, oval, almost transparent plate of bone beneath it. From the figure given of the mandible of *Idiurus macrotis* it is impossible to follow the form of the incisors, but in our new genus these teeth originate immediately beneath, or in the base of, the coronoid process, being therefore widely different from *Anomalurus*, in which genus these teeth germinate externally on a level with the last molar.

Type in British Museum. No. 98.5.4.6.

♂. Benito River (15 miles from mouth), 22nd Feb., 1898.

Measurements taken in the flesh:—Head and body 203 millim.; tail 167; hind foot 40; ear 22.

Fang name, oñiñ. "Caught in the hands, in a hollow tree" (*G. L. Bates*, collector).

Measurements of Skull:—Greatest length 46 millim.; basal length 39; zygomatic breadth 25·5; length of frontals 17; intertemporal constriction 7·5; length of nasals 13; greatest breadth of nasals 5; tip of nasals to gnathion 13·5; height of infraorbital foramen 10·5; breadth 5·7; diastema 11·5; antero-posterior depth of incisors 4; length of upper tooth-row 6; breadth between ms1 2; breadth of palate in front of molar series 3; length of auditory bulla 7·2; mandible, greatest length (bone only) 29, greatest depth 18; tips of incisors to condyle 34·5; back of incisors to coronoid 22, to condyle 29, to angle 22·3; length of lower tooth-row 6.

The great power and depth of the facial portion of the skull, the relative size of the teeth and form of the zygomatic processes of the maxillæ, the shape of the infraorbital foramina, the narrowness of the palate, and strength of the lower jaw are characters in which *Æthurus* resembles *Idiurus*; and the peculiar and highly specialized form of the tail, in which it resembles *Anomalurus*, places its affinity with that genus beyond doubt. On the one hand, therefore, we have cranial, on the other external characters of resemblance.

Unlike either of these genera, *Æthurus* possesses no flying-membranes, and the skull differs markedly in the frontal region.

The character of the tail seems to outweigh the peculiarities of the skull, which are mostly adaptive, though the form of the zygomatic process of the maxilla cannot be ignored.

Until younger specimens with less worn teeth are examined it would be difficult to say with which genus there is nearest relationship, or how the three genera stand in relation one to another.

Notes on the habits of this animal are looked forward to with great interest. The form of the jaws and teeth points to a diet similar to that of *Idiurus*, whatever that may be, presumably some extremely hard non-fibrous substance. The want of flying-membranes points to diurnal habits if the analogy of the squirrels may be taken as a guide, in which family all those with wings are nocturnal and those without wings diurnal. The single specimen being a male, it is impossible to say whether the curious hairs on the ankles are a sexual character or not; the true form of these hairs will be seen on reference to Plate XXXV. figs. 10-12.

[NOTE.—Since this paper was read, I find that Dr. Matschie had already described an animal, under the name of *Zenkerella insignis*, in a paper read before the Gesellschaft naturforschender Freunde zu Berlin (see Sitz. Ges. nat. Fr. Berl. 1898, No. 4), published the same day on which my paper was read. As these two forms seem to be identical, the proper name for this animal will be that proposed by Dr. Matschie; but since the name *Æthurus glirinus* had already been published both in the Abstract of the 'Proceedings' and in 'Nature,' it has been thought advisable to leave the present paper as originally read to the Society.

Dr. Matschie mentions the bad state of preservation of the feet of his specimen, and this, I think, will account for the discrepancies in the two descriptions of the fore feet.]

EXPLANATION OF THE PLATES.

PLATE XXXIV.

Æthurus glirinus, half nat. size.

PLATE XXXV.

- Fig. 1. Skull and mandible detached, side view, p. 452.
 2. Skull, front view, nat. size, p. 452.
 3. „ „ from above, nat. size.
 4. „ „ palatal view, nat. size.
 5. Mandible, from above, nat. size, p. 453.
 6. Right upper molar series, enlarged, p. 452.
 7. Right lower molar series, enlarged, p. 452.
 8. Fore foot, nat. size, p. 451.
 9. Hind foot, nat. size, p. 451.
 10. A hair of anklet, side view, enlarged, p. 451.
 11. „ „ from above, enlarged.
 12. „ „ cross section, enlarged.



J.Smit del. et lith.

Mintern.Bros. imp.

AETHURUS GLIRINUS.



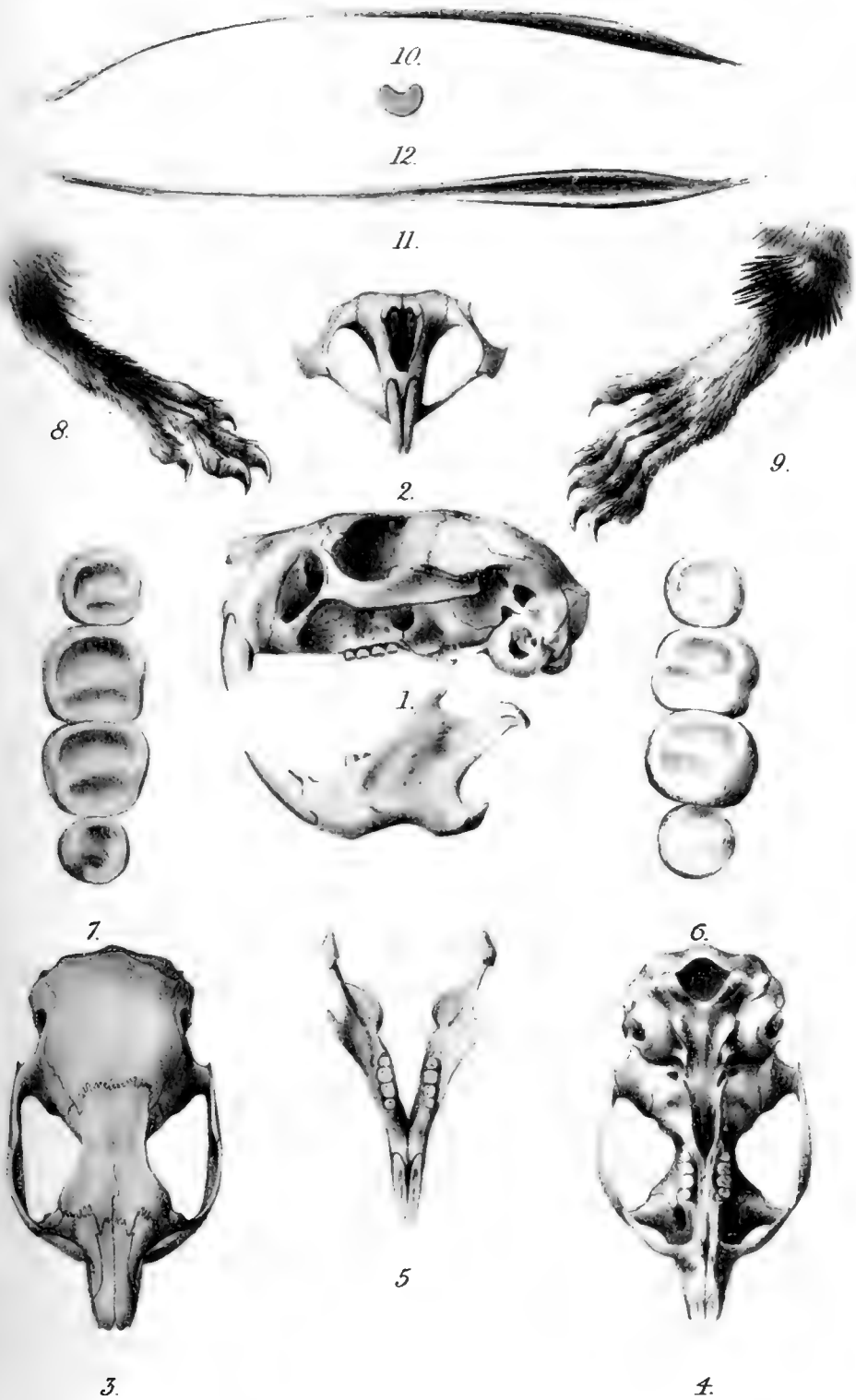

H. Grönvold, del.

Photoprint by Bale & Danielsson Ltd

AETHURUS GLIRINUS.



5. On the Identification of a Gecko from Penang.
By STANLEY S. FLOWER, 5th Fusiliers, F.Z.S.

[Received May 3, 1898.]

GONATODES AFFINIS.

Cyrtodactylus affinis, Stol. Journ. As. Soc. Beng. xxxix. 1870, p. 167, pl. x. fig. 1.

Gymnodactylus affinis, Boul. Cat. Liz. i. p. 42; S. Flower, P. Z. S. 1896, p. 862.

Gonatodes penangensis, S. Flower, P. Z. S. 1896, p. 863, pl. xlv. fig. 1.

In Stoliczka's figure of *Cyrtodactylus affinis* the pupil is represented as vertical, but in his description no mention is made of its shape; taking this figure as correct, the Gecko should be placed in the genus *Gymnodactylus*; but the figure being evidently drawn from a preserved specimen I consider it probable that the vertical pupil may be an addition of the artist, the eye in the original specimen being possibly in a bad state. I described *Gonatodes penangensis* without doubting the correctness of Stoliczka's figure, but since then careful search both by day and night in the locality, Penang Hill, has only shown two species belonging to this section of the Geckonidæ—one *Gymnodactylus pulchellus*, which is quite distinct; the other *Gonatodes penangensis*, which now on comparing with Stoliczka's original description and figure I have no doubt is his *Cyrtodactylus affinis*, the only discrepancy being the above-mentioned vertical pupil. *C. affinis* was described from a single specimen, a female, as Stoliczka mentions, there being no præanal or femoral pores; *G. penangensis* was described from five specimens (three ♂, one ♀, and one young), since then I have examined nine more (six ♂ and three ♀) and seen many others. The name should thus stand as *Gonatodes affinis* (Stol.).

Stoliczka says "shields of head small, those in front slightly enlarged and flattened," this character is not very noticeable; "a small shield above each nostril but not in contact," in one specimen out of nine recently examined they were in contact; he says that none of the chin-shields next the "lower rostral" (=symphysial) are "elongated," in most specimens one pair are, but occasionally these are broken up into small squarish shields, this was probably the case in his specimen; he does not mention the character of the scaling of the lower side of the digits.

His description of the coloration is good, but the wording differs from mine, he mentioning dark bands across the body, while I mention yellow ones; this seeming discrepancy being due to whether one takes the dark parts as bands and the light as interspaces or *vice versâ*.

The examination of further specimens confirms my opinion that the sexes do not differ in size or colour.

Largest ♂ measured in total length 109 mm. (snout to vent 49; tail 60).

Largest ♀ measured in total length 103 mm. (snout to vent 47; tail 56).

The number of præanal pores in six males examined was respectively 4, 4, 5, 5, 5, and 6.

Stoliczka's specimen was taken at an elevation of 2400 feet (J. A. S. B. 1870, p. 228); my first specimens were from 2200 feet, but since then I have obtained others from 2400 feet. It is exceptional to find these lizards on trees, their usual haunts being caves among the granite rocks, which are a feature of Penang Hill.

June 7, 1898.

Dr. A. GÜNTHER, F.R.S., Vice-President, in the Chair.

The Secretary read the following report on the additions to the Society's Menagerie during the month of May 1898:—

The registered additions to the Society's Menagerie during the month of May 1898 were 128 in number. Of these 78 were acquired by presentation, 16 by purchase, 11 were born in the Gardens, 6 were received by exchange, and 17 on deposit. The total number of departures during the same period, by death and removals, was 101.

Amongst these may be specially noticed:—

(1) A fine young female Mountain Zebra (*Equus zebra*), bred in the Garden of the Zoological Society of Amsterdam, purchased May 4th.

(2) A young male Leucoryx Antelope from Senegal, purchased May 20th.

(3) A young male Reindeer (*Rangifer tarandus*) from Newfoundland, presented by the Hon. M. A. Bourke, H.M.S. 'Cordelia,' May 21st. This animal, if it lives to come into good condition and develop a good head, will be of much interest, as it may enable us to appreciate the characters upon which the Reindeer of Newfoundland has lately been separated as a new species under the name of *Rangifer terræ-novæ*¹.

(4) Two Black-necked Swans (*Cygnus nigricollis*), hatched in the Gardens, May 28th. It is now nearly 20 years since we have had a good breeding pair of this lovely Swan in the Gardens. The species is certainly a delicate one, and has not of late years done well with us, having been continually replaced by specimens purchased on the Continent. Fresh imported birds of this species would be very desirable, as most of the birds on sale nowadays have been bred in Egypt.

¹ See O. Bangs, 'Description of Newfoundland Caribou,' Boston, 1896. J. A. Allen, Bull. Amer. Mus. viii. p. 233 (1896).

A communication was read from Mr. L. W. Wigglesworth, entitled "Theories of the Origin of Secondary Sexual Characters," which contained arguments in favour of the theory of the stimulation of parts to higher development through use or external violence or irritation, as observed in birds.

The following papers were read :—

1. On some Crustaceans from the South Pacific.—Part II.
*Macrura anomala*¹. By L. A. BORRADAILE, M.A.,
F.Z.S., Lecturer in Natural Sciences at Selwyn College,
Cambridge.

[Received April 28, 1898.]

(Plate XXXVI.)

The collections with which the present paper deals were made in the islands of Funafuti (Ellice group) and Rotuma by Mr. J. Stanley Gardiner, to whom I am much indebted for information respecting the habits &c. of several of the species. The facts with which Mr. Gardiner has furnished me will be given, in his own words, under the species they refer to.

The Funafuti collection comprised examples of the following species :—

1. *Birgus latro* (Linn.). 2 ♂, 5 ♀.
2. *Cænobita perlatus* H. M.-Edw. 2 ♂.
3. *Cænobita rugosus* H. M.-Edw. 4 ♂.
Var. *pulcher* Dana. 4 ♂, 4 ♀.
4. *Pagurus setifer* H. M.-Edw. 1 ♀.
5. *Pagurus euopsis* Dana. 1 ♀.
6. *Aniculus typicus* Dana. 1 ♂, 1 ♀.
7. *Calcinus elegans* (H. M.-Edw.). 1 ♂, 4 ♀.
8. *Calcinus herbsti* de Man. 11 ♂, 13 ♀.
Var. *lividus* (H. M.-Edw.). 2 ♂.
9. *Calcinus latens* (Randall). 6 ♂, 5 ♀.
10. *Clibanarius corallinus* (H. M.-Edw.). 7 ♂, 6 ♀.
11. *Clibanarius æquabilis* Dana. 3 ♂.
12. *Clibanarius zebra* Dana. 2 ♂.
13. *Diogenes pallescens* Whitelegge. 2 ♂.
14. *Galathea affinis* Ortmann. 2 ♂.
15. *Petrolisthes lamarcki* (Leach). 2 ♂, 5 ♀.
Var. *asiaticus* (Leach). 2 ♀.
Var. *rufescens* (Heller). 4 ♂, 3 ♀.
Var. *fimbriatus*, nov. 1 ♂, 1 ♀.
16. *Remipes pacificus* Dana. 30 ♂, 12 ♀.

¹ For Part I., see P. Z. S. 1898, p. 32.

The collection from Rotuma contained examples of:—

1. *Cænobita spinosus* H. M.-Edw. 1 ♂, 2 ♀.
2. *Cænobita perlatus* H. M.-Edw. 2 ♂.
3. *Cænobita rugosus* H. M.-Edw. 22 ♂, 17 ♀.
Var. *pulcher* Dana. 1 ♂, 5 ♀.
4. *Pagurus deformis* H. M.-Edw. 2 ♂.
5. *Pagurus punctulatus* Olivier. 1 ♂, 3 ♀.
6. *Aniculus typicus* Dana. 1 ♂.
7. *Calcinus elegans* (H. M.-Edw.). 2 ♂, 2 ♀.
8. *Calcinus herbsti* de Man. 1 ♂, 3 ♀.
Var. *lividus* (H. M.-Edw.). 1 ♂, 3 ♀.
9. *Calcinus gaimardi* (H. M.-Edw.). 2 ♂.
10. *Calcinus latens* (Randall). 4 ♂, 1 ♀.
11. *Galathea affinis* Ortmann. 3 ♂.
12. *Petrolisthes lamarcki* (Leach). 5 ♂, 2 ♀.
Var. *rufescens* (Heller). 5 ♂, 7 ♀.
Var. *asiaticus* (Leach). 8 ♂, 4 ♀.
Var. *fimbriatus*, nov. 1 ♂, 2 ♀.
13. *Remipes pacificus* Dana. 18 ♂, 58 ♀.

I proceed to remarks on the several species.

Subtribe PAGURINEA.

Family CÆNOBITIDÆ.

Genus BIRGUS Leach, 1815.

1. BIRGUS LATRO (Linn.), 1766.

Cancer latro, Linnæus, Syst. Nat. ed. 12, ii. p. 1049 (1766).

Pagurus latro, Fabricius, Ent. Syst., Supp. p. 411 (1798).

Birgus latro, Leach, Tr. Linn. Soc. Lond. xi. p. 337 (1815);
H. Milne-Edwards, H. N. Crust. ii. p. 246 (1837); Atlas to
Cuvier's R. An. 3rd ed. pl. xiii. fig. 1 (no date); Dana, U.S. Expl.
Exped., Crust. i. p. 474, pl. xxx. fig. 2 (1852).

(Juv.). *Birgus laticauda*, Latreille, R. An. 2nd ed. iv. pl. xii.
fig. 2 (1829).

The tree-climbing habits of this species have been a subject of so much discussion that I have asked Mr. Gardiner for a special note on the point. He says:—"The robber crab is very commonly found in the tops both of Pandanus and of coconut-trees, from which latter I have had it thrown down to me by the natives. It is stated by them to break off the nuts and often to fall with them, never killing itself, as the coconut is underneath. I have seen them constantly clinging to the fruit of the Pandanus, the fallen segments of which, after they have been chewed by the crab, cover the ground. Although all the specimens are from Funafuti, the crab is also very common at Rotuma."

Two males and five females from Funafuti.

Genus CÆNOBITA Latreille, 1826.

2. CÆNOBITA SPINOSUS H. M.-Edw., 1837.

Cænobita spinosa, H. Milne-Edwards, H. N. Crust. ii. p. 242 (1837).

Cænobita brunnea, Dana, U.S. Expl. Exped., Crust. i. p. 470, pl. xxix. fig. 10 (1852).

Birgus hirsutus, Hess, Decap. Krebs. O.-Austral. p. 36, pl. vii. fig. 16 (1865).

Cænobita spinosus, Ortmann, Zool. Jahrb. vi. Syst. p. 318, pl. xii. fig. 24 (1892).

? *Cænobita olivieri*, Owen, Voy. 'Blossom,' p. 84; Dana, U.S. Expl. Exped., Crust. i. p. 470 (1852).

One male and two female specimens from Rotuma, in nutshells of *Calophyllum inophyllum* Linn. Mr. Gardiner says: "All three specimens were obtained between the stones of a built-up graveyard on the top of Sol-Hoi, Rotuma (about 600 feet above the sea-level)."

3. CÆNOBITA PERLATUS H. M.-Edw., 1837.

Cænobita perlata, H. Milne-Edwards, H. N. Crust. ii. p. 242 (1837); Atlas to Cuvier's R. An. pl. xlv. fig. 1 (no date).

Cænobita purpurea, Stimpson, Proc. Ac. N. Sci. Philad. 1858, p. 245.

Cænobita perlatus, Ortmann, Zool. Jahrb. vi. Syst. p. 319 (1892).

Two males from Rotuma. Two males from Funafuti, in shells of *Turbo* and *Ranella*.

With reference to this and the succeeding species, Mr. Gardiner says:—" *Cænobita perlatus* and *C. clypeatus* are found in all the islands of Funafuti, often on the Pandanus-trees. During the daytime they hide under the heaps of coconut-shells and in holes, but at night they swarm in every direction. They are used by the natives as bait for fishing. *C. perlatus* occurs also in Rotuma, where it is found on the beach sand-flats, but is not very numerous."

4. CÆNOBITA CLYPEATUS (Herbst), 1796.

Cancer clypeatus, Herbst, Naturg. Krabb. u. Krebse, ii. p. 22, pl. xxiii. fig. 2 (1796).

Pagurus clypeatus, Fabricius, Ent. Syst., Supp. p. 413 (1798).

Cænobita clypeata, Latreille, Fam. Nat. R. An. p. 277 (1826); H. Milne-Edwards, H. N. Cr. ii. p. 239 (1837); Dana, U.S. Expl. Exped., Crust. i. p. 473, pl. xxx. fig. 4 (1852).

Cænobita clypeatus, Ortmann, Zool. Jahrb. vi. Syst. pp. 315, 316, pl. xii. fig. 20 (1892).

Three males and one female from Funafuti, one in a *Turbo* shell.

5. *CÆNOBITA RUGOSUS* H. M.-Edw., 1837.

Cænobita rugosa, H. Milne-Edwards, H. N. Cr. ii. p. 241 (1837); Dana, U.S. Expl. Exped., Crust. i. p. 471, pl. xxx. figs. 1, 2 (1852).

Cænobita cavipes, Stimpson, Proc. Ac. N. Sci. Philad. 1858, p. 245.

Cænobita rugosus, Ortmann, Zool. Jahrb. vi. Syst. p. 317, pl. xii. fig. 22 (1892).

This species is "very common along the lagoon shores of Funafuti, and along the shore between tide-marks at Rotuma."

Four males from Funafuti, in shells of a *Turbo* and of two species of *Nerita*. Twenty-two males and seventeen females from Rotuma, one in a *Turbo* shell.

Var. *PULCHER* Dana, 1852 (*loc. cit.*).

Four male specimens and four females from Funafuti, in *Nerita* shells. One male and five females from Rotuma.

Family PAGURIDÆ.

Subfamily PAGURINÆ.

Genus PAGURUS Fabr., 1798, *restrictum*.6. *PAGURUS DEFORMIS* H. M.-Edw., 1836.

Pagurus deformis, H. Milne-Edwards, Ann. Sci. Nat. 2, ii. p. 272, pl. xiii. fig. 4 (1836); id. H. N. Cr. ii. p. 222 (1837); Hilgendorf, Mon.-Ber. Ak. Wiss. Berlin, 1878, p. 818, pl. iii. figs. 6, 7; Ortmann, Zool. Jahrb. vi. Syst. p. 288; Semon's 'Forschungsreisen in Austral.' v. 1, p. 31 (1894).

Hilgendorf (*loc. cit.*) and Ortmann (Zool. Jahrb. *loc. cit.*) have both remarked that the males of this species show the female openings on the second pair of walking-legs. I have attempted to dissect a spirit-specimen in order to discover the condition of the internal generative organs, but the preservation was so bad as to render this useless. Another point of interest to determine would be whether *P. pedunculatus* and *P. asper*, species allied to the present, do or do not share this peculiarity with it. *P. gemmatus* does not, to judge from a male specimen in Dr. Willey's collection.

Of the two specimens of *P. deformis* in Mr. Gardiner's collection, both are males from Rotuma, and one is of interest in that it has the female opening of the left side only, that of the right side being completely absent.

7. *PAGURUS SETIFER* H. M.-Edw. 1836.

Pagurus setifer, H. Milne-Edwards, Ann. Sci. Nat. 2, vi. p. 274 (1836); id. H. N. Cr. ii. p. 225 (1837); Hilgendorf, Mon.-Ber. Ak. Wiss. Berlin, 1878, p. 815, pl. iii. fig. 8; de Man, Arch. f.

Naturog. 53, i. p. 433 (1887); Ortmann, *Zool. Jahrb. vi. Syst.* p. 287, x. *Syst.* p. 275. *Non de Haan, Faun. Japon.* p. 209 (1850); Henderson, *Tr. Linn. Soc. Lond.* 2, v. pt. 10, p. 420 (1893).

Eupagurus setifer, Haswell, *Cat. Austral. Crust.* p. 154 (1882).

This species is closely allied to *P. guttatus* Olivier, so that it is just possible that the record of the latter species from Funafuti by Whitelegge (*Funafuti Atoll, Crustacea*, p. 143) may be a mistake.

Mr. Gardiner says that *P. setifer* is "stated by the natives to be very rare, and found only on the southern islands of the atoll. It is caught on land at night."

One male specimen from Funafuti.

8. PAGURUS EUOPSIS Dana, 1852.

Pagurus euopsis, Dana, *U.S. Expl. Exped., Crust.* i. p. 452, pl. xxviii. fig. 6 (1852).

I am informed by Mr. Gardiner that this species is caught on land at night.

One female from Funafuti, two males from Rotuma.

9. PAGURUS PUNCTULATUS Olivier.

Pagurus punctulatus, Olivier, *Encycl. Méth.* viii. p. 641; H. Milne-Edwards, *Ann. Sci. Nat.* 2, vi. p. 273 (1836); *id.* *H. N. Cr.* ii. p. 222 (1837); Dana, *U.S. Expl. Exped., Crust.* i. p. 451, pl. xxviii. fig. 4 (1852).

One male and three females from Rotuma; the male in the shell of a *Malea ringens*.

Genus ANICULUS Dana, 1852.

10. ANICULUS TYPICUS Dana, 1852.

Pagurus aniculus, Fabricius, H. Milne-Edwards, *Ann. Sci. Nat.* 2, vi. p. 279 (1836); *id.* *H. N. Cr.* ii. p. 230 (1837).

Aniculus typicus, Dana, *U.S. Expl. Exped., Crust.* i. p. 461, pl. xxix. fig. 1 (1852).

Pagurus (Aniculus) aniculus, Hilgendorf, *Mon.-Ber. Ak. Wiss. Berlin*, 1878, p. 824.

One male from Rotuma. One male and one female from Funafuti, in *Turbo* shells.

Genus CALCINUS Dana, 1852.

11. CALCINUS ELEGANS (H. M.-Edw.), 1836.

Pagurus elegans, H. Milne-Edwards, *Ann. Sci. Nat.* 2, vi. p. 278, pl. xiii. fig. 2 (1836); *H. N. Cr.* ii. p. 229 (1837).

Pagurus decorus, Randall, *Journ. Ac. Nat. Sci. Philad.* viii. p. 135 (1839).

Calcinus elegans, Dana, U.S. Expl. Exped., Crust. i. p. 458, pl. xxviii. fig. 10 (1852).

One male and four females from Funafuti. Two males and two females from Rotuma.

12. CALCINUS HERBSTI de Man, 1887.

Pagurus tibicen, H. Milne-Edwards, Ann. Sci. Nat. 2, vi. p. 278 (1836); H. N. Cr. ii. p. 229 (1837); Atl. Cuv. R. An. pl. xlv. fig. 3.

Pagurus lividus, H. Milne-Edwards, Ann. Sci. Nat. 3, x. p. 63 (1848).

Calcinus tibicen, Dana, U.S. Expl. Exped., Crust. i. p. 457 (1852); Heller, 'Novara' Crust. p. 87 (1865); Henderson, 'Challenger' Anom. p. 61 (1888); Whitelegge, Funafuti Atoll, Crust. p. 144 (1897).

Pagurus (Calcinus) tibicen, Hilgendorf, Mon.-Ber. Ak. Wiss. Berlin, 1878, p. 823.

Calcinus herbstii, de Man, Arch. f. Naturg. 53, i. p. 437 (1887).

Calcinus herbsti, Ortuann, Zool. Jahrb. iv. Syst. p. 292 (1892).

Non *Cancer tibicen*, Herbst, Krabb. u. Krebse, ii. pl. xxiii. fig. 7 (1796).

? *Pagurus laevimanus*, Randall, Journ. Ac. Nat. Sci. Philad. viii. p. 135 (1839).

There can, I think, be no doubt that the *Pagurus lividus* of Milne-Edwards is a mere colour-variety of this species. Beyond the absence of colour, the only difference given in the definition is that the legs are "finement pointillées," and this statement, as a matter of fact, applies equally well to the most brilliantly coloured specimens. On the other hand, I have Mr. Gardiner's authority for stating that the specimens which I have considered to belong to the var. *lividus* were really colourless when alive, and have not been merely bleached by the alcohol. One of them shows faint traces of the characteristic brown patch on the left "hand."

One male and three females from Rotuma; eleven males and thirteen females from Funafuti. The Funafuti specimens are in shells of the following genera of Gastropoda:—*Ricinula*, *Angina*, *Strigatella*, *Nerita*, *Purpura*, *Peristernia*.

Var. *lividus* (H. M.-Edw.), 1848. One male specimen and one female from Rotuma. Two females from Funafuti in shells of *Nerita*.

13. CALCINUS GAIMARDI (H. M.-Edw.), 1848.

Pagurus gaimardii, H. Milne-Edwards, Ann. Sci. Nat. 3, x. p. 63 (1848).

Calcinus gaimardii, Dana, U.S. Expl. Exped., Crust. i. p. 457, pl. xxviii. fig. 9 (1852).

Calcinus gaimardi, Ortmann, Zool. Jahrb. vi. Syst. p. 294 (1882).

Two males from Rotuma.

14. *CALCINUS LATENS* (Randall), 1839.

Pagurus latens, Randall, Journ. Ac. Nat. Sci. Phil. viii. p. 135 (1839).

Calcinus latens, Dana, U.S. Expl. Exped., Crust. i. p. 459, pl. xxviii. fig. 11 (1852).

Six males and five females from Funafuti; one in a *Cerithium* shell. Four males and one female from Rotuma.

Genus *CLIBANARIUS* Dana, 1852.15. *CLIBANARIUS CORALLINUS* (H. M.-Edw.), 1848.

Pagurus corallinus, H. Milne-Edwards, Ann. Sci. Nat. 3, x. p. 63 (1848).

Clibanarius corallinus, Dana, U.S. Expl. Exped., Crust. i. p. 468, pl. xxix. fig. 8 (1852); de Man, Arch. f. Naturg. 53, i. p. 447 (1887); Ortmann, Zool. Jahrb. vi. Syst. p. 292 (1892).

Clibanarius obesomanus, Dana, Proc. Ac. Nat. Sci. Philad. 1851.

Clibanarius globosimanus, Stimpson, Proc. Ac. Nat. Sci. Philad. 1858, p. 247.

Seven males and six females from Funafuti. In shells of *Purpurea*, *Peristernia*, *Cerithium*, *Nerita*, *Ricinula*, *Angina*.

16. *CLIBANARIUS ÆQUABILIS* Dana, 1852.

Clibanarius æquabilis, Dana, U.S. Expl. Exped., Crust. i. p. 464, pl. xxix. figs. 4 a-f (1852).

Three males from Funafuti.

17. *CLIBANARIUS ZEBRA* Dana, 1852.

Clibanarius zebra, Dana, U.S. Expl. Exped., Crust. i. p. 465, pl. xxix. figs. 5 a-d (1852).

Two males from Funafuti.

Genus *DIOGENES* Dana, 1852.18. *DIOGENES PALLESCENS* Whitelegge, 1897.

Diogenes pallescens, Whitelegge, Funafuti Atoll, Crust. p. 141, pl. vi. figs. 2 a, b, c (1897).

Two males from Funafuti.

Subtribe *GALATHEINEA*.Family *GALATHEIDÆ*.Genus *GALATHEA* Fabricius, 1798.19. *GALATHEA AFFINIS* Ortmann, 1892.

Galathea affinis, Ortmann, Zool. Jahrb. vi. Syst. p. 252, pl. xi. fig. 9 (1892).

Three males from Rotuma. Two males from Funafuti.

Subtribe PORCELLANINEA.

Family PORCELLANIDÆ.

Genus PETROLISTHES Stimpson, 1858.

20. PETROLISTHES LAMARCKI (Leach), 1820. (Plate XXXVI. figs. 1, 1a, 1b, 2.)

(1) Type.

Pisidia lamarckii, Leach, Dict. Sci. Nat. xviii. p. 54 (1820).

Porcellana speciosa, Dana, U.S. Expl. Exped., Crust. i. p. 417, pl. xxvi. fig. 8 (1852) [in part].

Porcellana bellis, Heller, 'Novara' Crust. p. 76, pl. vi. fig. 4 (1865).

Porcellana dentata, de Man, Journ. Linn. Soc. Lond. xxii. p. 216 (1888).

Petrolisthes speciosus, Stimpson, Proc. Acad. Nat. Sci. Philad. 1858, pp. 227 & 241; Ortmann, Zool. Jahrb. vi. Syst. p. 262 (1892); ? Whitelegge, Funafuti Atoll, Crust. p. 144 (1897).

Petrolisthes haswelli, Miers, Rep. Zool. Coll. 'Alert,' p. 269, pl. xxix. fig. A (1884); Whitelegge, Funafuti Atoll, Crust. p. 144 (1897).

Porcellana (Petrolisthes) dentata, de Man, Arch. f. Naturg. 53, i. p. 409, pl. xviii. fig. 7 (1887).

Petrolisthes lamarcki, Stimpson, Proc. Ac. Nat. Sci. Phil. 1858, p. 227; Miers, Rep. Zool. 'Alert,' pp. 268 & 557 (1884); Ortmann, Semon's 'Forschungsreisen in Austral.' v. 1, p. 26 (1894).

(2) Var. ASIATICUS (Leach), 1820.

Pisidia asiatica, Leach, Dict. Sci. Nat. xviii. p. 54 (1820); Desmarest, Consid. sur les Crust. p. 198.

Porcellana asiatica, Gray, Zool. Misc. p. 15 (1831); H. Milne-Edwards, H. N. Cr. ii. p. 252 (1837); Richter's Decap. Ins. Mauritius, p. 159, pl. xvii. fig. 13 (1880).

Porcellana armata, Gibbes, Proc. Am. Assoc. iii. p. 190 (1850); id. Proc. Elliot Soc. i. p. 11, pl. i. fig. 4 (1854); v. Martens, Arch. f. Naturg. 38, i. p. 121, pl. v. fig. 11 (1872).

Porcellana speciosa, Dana, U.S. Expl. Exped., Crust. i. p. 417 (1852), in part.

Porcellana gundlachii, Guérin, de la Sagra's Hist. Cuba, Anim. Artic. p. 39, pl. ii. fig. 6 (1857); v. Martens, Arch. Naturg. 38, i. p. 122, pl. v. fig. 12 (1872), *juv.*

Porcellana leporina, Heller, Verh. zool.-bot. Ges. Wien, p. 523 (1862); 'Novara' Crust. p. 78, pl. vi. fig. 7 (1865).

Petrolisthes asiaticus, Stimpson, Proc. Acad. Nat. Sci. Phil. 1858, p. 227; de Man, Zool. Jahrb. ix. Syst. p. 376 (1896), *juv.*

Petrolisthes armatus, Stimpson, Proc. Ac. Nat. Sci. Philad. 1858, p. 227; Ann. Lyc. N.Y. vii. p. 73 (1862); Streets, Proc. Ac. Nat. Sci. Philad. 1871, p. 204; Lockington, Ann. Mag. Nat. Hist. 5, ii. p. 339 (1878); Kingsley, Proc. Acad. Nat. Sci. Phil. 1879,

p. 406; Henderson, 'Challenger' Anom. p. 105 (1888); Heilprin, Proc. Ac. Nat. Sci. Phil. 1888, p. 320; Ortmann, Dec. Schiz. Plankton Exped. p. 51 (1893); Zool. Jahrb. x. Syst. p. 280 (1897).

Petrolisthes marginatus, Stimpson, Ann. Lyc. Nat. Hist. vii. p. 74 (1862).

Petrolisthes leporinoides, Ortmann, Zool. Jahrb. vi. Syst. p. 263 (1892); Semon's 'Forschungsreisen in Austral.' v. 1, p. 26 (1894).

Petrolisthes dentatus, Henderson, Tr. Linn. Soc. Lond. 2, v. p. 426 (1893).

Petrolisthes dentatus var., de Man, Zool. Jahrb. ix. Syst. p. 374 (1896), in part.

Petrolisthes lamarcki var. *asiaticus*, Miers, Zool. 'Alert,' pp. 269 & 557 (1884).

(3) Var. RUFESCENS (Heller), 1861.

? *Porcellana dentata*, H. Milne-Edwards, H. N. Crust. ii. p. 251 (1837); Dana, U.S. Expl. Exped., Crust. i. p. 419 (1852).

Porcellana rufescens, Heller, Sitz.-Ber. Ak. Wiss. Wien, xlv. p. 255, pl. ii. fig. 4 (1861); 'Novara' Crust. p. 76 (1865); ? Kossmann, Ergebn. Zool. Reise, ii. 1, pp. 75-78 (1880).

Petrolisthes dentatus, Stimpson, Proc. Ac. Nat. Sci. Philad. 1858, p. 227; Haswell, Cat. Austr. Crust. p. 146 (1882); Ortmann, Zool. Jahrb. vi. Syst. p. 262 (1892).

Porcellana (Petrolisthes) rufescens, Hilgendorf, Mon.-Ber. Ak. Wiss. Berlin, p. 825, pl. ii. fig. 7 (1878).

Petrolisthes lamarcki, Ortmann, Semon's 'Forschungsreisen in Austral.' v. 1, p. 26 (1894), in part.

The full synonymy which I have felt obliged to give for this very variable species reveals the remarkable fact that it has been described under no fewer than twelve names. In default, however, of any reliable separating character of specific value, I am compelled to include all its various forms under one head.

Colour is of course useless to us as a specific character. It is here very variable, and its variations run counter to those of other characteristics. The extreme forms are on the one hand almost white, and on the other dark red blotched with dark purple. The *P. speciosus* of Dana comprised light-coloured forms with red or purple spots. Some of these varieties are extremely beautiful. Again the number, size, and arrangement of the teeth on the inner side of the wrist of the chelæ show great variations. But the number increases with age, and the limbs of the two sides are often different, so that any distinctions founded on these must be abandoned. Extreme forms are:—(1) a wavy edge with a large hump at the near end, and (2) the same edge bearing a row of five well-defined teeth, with hints of a sixth. The teeth may be sharp or blunt in otherwise similar forms, or may become bicuspid, seemingly by two running together. Leach's original *P. lamarcki* had three teeth; *P. asiaticus* Leach, *P. leporina* Heller, *P. leporinoides* Ortmann, *P. armatus* Gibbes, and *P. gundlachi* Guérin,

resemble it in this respect. In *P. marginatus* Stimpson the number tends to increase. *P. bellis* Heller, *P. speciosus* Dana, *P. haswelli* Miers, *P. dentata* H. M.-Edw., and *P. rufescens* Heller, have at least four.

The spines on the upper edge of the merus of the walking-legs are another character which it has been attempted to use as specific. They are, however, so inconstant, and form such a complete series, from specimens with an almost straight edge (Plate XXXVI. fig. 1a), through those with imbricating scales, to those with well-marked spines, that it seems impossible to make use of them. The best-marked of these spines is about a third of the length from the far end of the joint (fig. 1b). Often this spine appears on one or a few legs only, and as often as not the legs of the two sides do not agree. In Leach's original specimen of *P. asiaticus* in the British Museum, the first two walking-legs on the left side alone show spines. The type specimen of *P. lamarckii* is without them.

Then there is the epibranchial spine, whose presence or absence would seem to afford an excellent criterion for our purposes. According to Ortmann, however (Semon's 'Forschungsreisen in Austral.' *loc. cit.*), this is not of specific value, since it occurs in specimens from the same locality as, and in other respects exactly resembling, forms without such spines.

The breadth of various joints of the limbs varies, but is not to be relied upon, since it appears to alter with age.

Lastly, I have ventured to name a new variety, *fimbriatus*, from the fact of its possessing a more or less plentiful fringe of hairs to the outer margin of the "hand" (Plate XXXVI. fig. 2).

The following key indicates the characters attaching to those varietal names which it appears advisable to retain:—

- A. With an epibranchial spine. Colour tends to sprinkling of red spots on lighter ground.
 - i. Without a fringe to the outer side of the chelæ.
 - 1. Without spines on the anterior margin of the merus of any walking-leg *Type* (Leach), 1820.
 - 2. With at least one spine on the anterior margin of the merus of at least one of the walking-legs. Usually with spines on several legs.
 - Var. *asiaticus* (Leach), 1820.
 - ii. With a scanty or plentiful fringe to the outer side of the chelæ. With or without spines on the anterior margins of the walking-legs.
 - Var. *fimbriatus*, nov.
- B. Without an epibranchial spine. Colour tends to red or white with large blotches of purple or blue. Attains a larger size than (A), has a greater average of teeth on the inner margin of the wrist, but none on the merus of any walking-leg. Exhibits its peculiarities in small specimens, and is therefore not merely a collection of older individuals. Possibly a distinct species Var. *rufescens* (Heller), 1861.

I should have used Milne-Edwards's name of *dentatus* for this latter form, since his definition would agree very well with the specimens, but de Man states very positively (*Zool. Jahrb.* ix. p. 374) that he has had the original specimens sent him from Paris and that they possess an epibranchial spine. Should there not be, as

Ortmann suspects (Semon's 'Forschungsreisen in Austral.' *loc. cit.*), a mistake about these specimens, *dentatus* thus becomes a synonym for *lamarckii* Leach, and *rufescens* Heller is next in order of priority among the names for forms without an epibranchial spine. The specimens of var. *fimbriatus* nov. are all small (carapace 4-5 mm. long) and are of a white or yellow colour with red spots.

There is a very distinct difference in coloration between the Rotuma and Funafuti specimens of this species, the latter being much lighter in colour than the former. This difference runs through all the varieties, and I am informed by Mr. Gardiner that the specimens have not undergone much change of colour since they were collected.

Five males and two females from Rotuma; two males and five females from Funafuti.

Var. *asiaticus* (Leach), 1820. (Plate XXXVI. fig. 1 b.)

Eight males and four females from Rotuma; two females from Funafuti.

Var. *fimbriatus*, nov. (Plate XXXVI. fig. 2.)

One male and two females from Rotuma; one male and one female from Funafuti.

Var. *rufescens* (Heller), 1861.

Five males and seven females from Rotuma; four males and three females from Funafuti.

Subtribe HIPPINEA.

Family HIPPIDÆ.

Genus REMIPES Latr., 1806.

21. REMIPES PACIFICUS Dana, 1852. (Plate XXXVI. figs. 3a-i.)

Remipes pacificus, Dana, U.S. Expl. Exped., Crust. i. p. 407, pl. xxv. fig. 7 (1852); de Man, Zool. Jahrb. ix. Syst. p. 476 (1897), x. Syst. pl. xxxiii. fig. 53 (1898).

Remipes testudinarius, Miers, J. Linn. Soc. Lond., Zool. xiv. p. 318, pl. v. fig. 2 (1879).

Remipes adactylus, Ortmann, Zool. Jahrb. ix. Syst. p. 228 (1897).

Of forty-one specimens of this species from Funafuti all had the normal number of joints to the second antennæ. Of seventy-six specimens from Rotuma no fewer than eight, or more than ten per cent., showed abnormalities. In one of this eight the two sides varied alike, both having a 3-jointed flagellum, as opposed to the two-jointed normal form. Five of the remaining seven had the flagellum of the left antenna normal, while, in the right, one specimen had the penultimate joint partially divided into two; two specimens had three joints, one had four joints, and one had five joints. The remaining two abnormal specimens had the right antenna normal, while in the left the flagellum was three-jointed. One of these latter was the only abnormal male, all the rest being

females, some bearing eggs. The length of the carapace varied from 12 to 20 mm., and there was no correspondence between the size of the individuals and the number of joints in their antennæ.

No two of the abnormal antennæ were exactly alike. Thanks to the excellent diagnoses given by de Man (*loc. cit.*) for the *testudinarius*-group of *Remipes*, I have been able to satisfy myself that all the above specimens, including the first-mentioned with three-jointed flagella on both the second antennæ, were true *R. pacificus*.

On Plate XXXVI. fig. 3 *a* represents a normal second antenna in this species; figs. 3 *b-i* show the abnormal specimens in the order in which I have alluded to them.

Twenty-nine males and eleven females from Funafuti; eighteen males and fifty-eight females from Rotuma.

EXPLANATION OF PLATE XXXVI.

- Fig. 1. *Petrolisthes lamarcki* (Leach), $\times 1\frac{1}{2}$, p. 464.
 1 *a.* " " " right third leg.
 1 *b.* " " var. *asiaticus* (Leach), right third leg, p. 467.
 2. " " var. *imbriatus*, nov., $\times 3$, p. 467.
 3 *a-i.* *Remipes pacificus*, Dana, second antennæ, $\times 7$, p. 467.
 a, normal form; *b-i*, abnormal.
 b-g, right antennæ; *h* & *i*, left antennæ.
 a-h, ♀; *i*, ♂.

NOTE.—Errata in Part I. of this paper:—On pp. 33, l. 30, and 37, l. 4, for "Blanche Bay, Loyalty Islands," read "Blanche Bay, New Britain." On p. 34, l. 25, omit "smooth."

2. Report on the Gephyrean Worms collected by Mr. J. Stanley Gardiner at Rotuma and Funafuti. By ARTHUR E. SHIPLEY, F.Z.S., Fellow and Tutor of Christ's College, Cambridge, and University Lecturer in the Advanced Morphology of the Invertebrata.

[Received May 13, 1898.]

(Plate XXXVII.)

The Gephyrea collected by Mr. J. Stanley Gardiner during his visits to Rotuma and Funafuti in the years 1896–97 comprise specimens of two species of the Echiuroidea and twelve of the Sipunculoidea. Of the latter, two species of *Sipunculus* are in my opinion new, whilst a third, *Physcosoma*¹ *varians* Kef., is, so far as I know, recorded for the first time from the Pacific.

In nearly all the cases where species are common to the two localities, the specimens from Funafuti were considerably smaller than those from Rotuma.

¹ The reason for adopting the generic name *Physcosoma* in place of *Phymosoma* (*Phymosomum* Quatrefages) is given by Selenka in the Zool. Anz. Band xx. No. 546, 1897, p. 460.

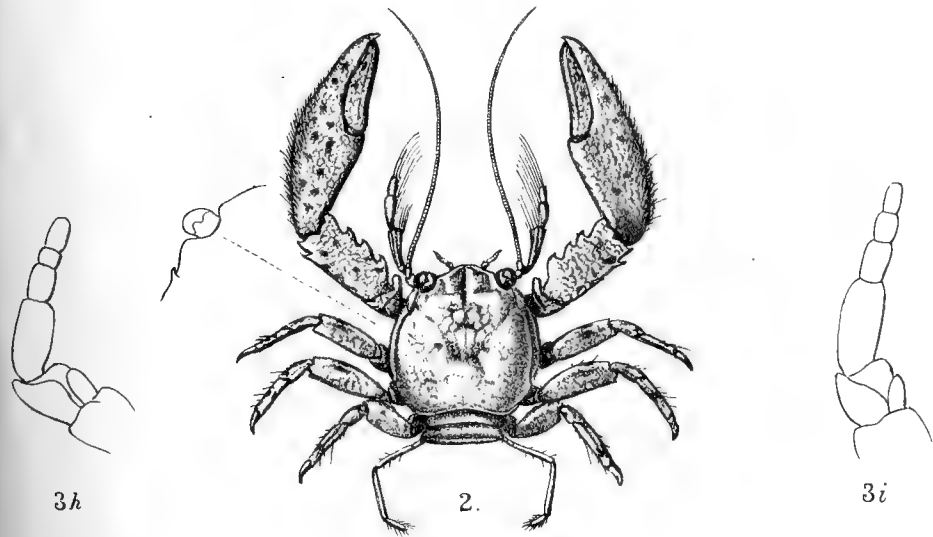
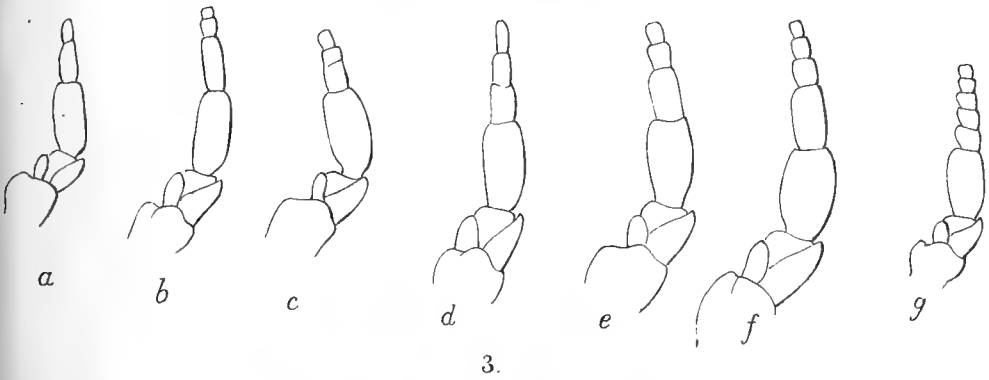
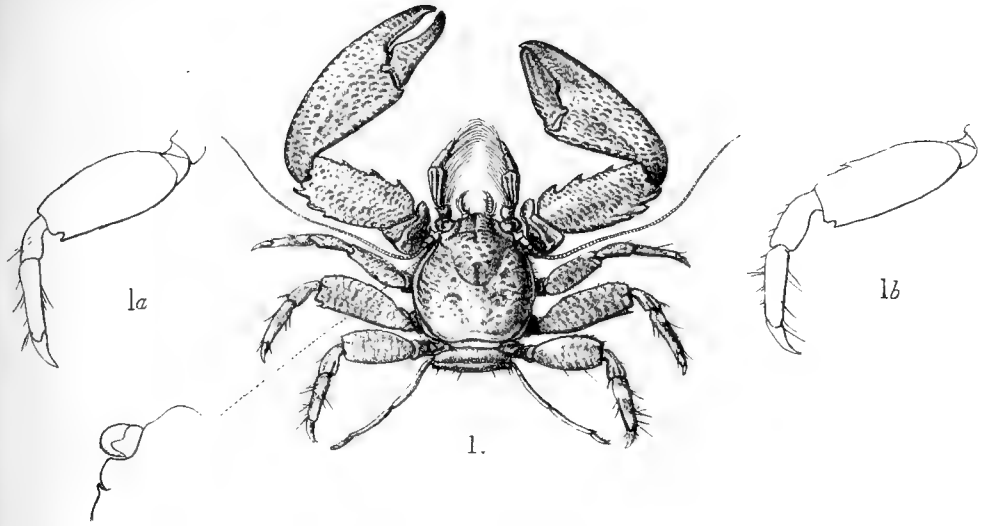

Edwin Wilson. Cambridge.

MACRURA ANOMALA FROM THE SOUTH PACIFIC.



1. *SIPUNCULUS VASTUS* Sel. & Bülow.

One specimen from Rotuma, numerous smaller specimens from Funafuti.

In the analytical key in Selenka's "Sipunculiden"¹ the number of longitudinal muscles in this species is given as 31, but in the description of the species the number is 27. In the present specimens the number varies from 25 to 27 in different regions of the body, neighbouring bands sometimes, though not very often, fusing with one another. The characteristic diverticula on the hind-gut are well marked.

The numerous specimens from Funafuti are all comparatively small, being about 5-7 cm. in length; the single example from Rotuma measured 16 cm. in length with its introvert retracted. Mr. Gardiner reports that this species is extremely common on the outer reef under the loosely cemented masses of rock.

Besides the specimens from Rotuma and Funafuti, the species is also recorded from Jaluit and Mauritius.

2. *SIPUNCULUS ROTUMANUS*, n. sp. (Plate XXXVII. figs. 1, 2, & 3.)

Eight specimens from Rotuma.

This species is closely allied to *S. cumanensis* Kef. and *S. edulis* (?) Lamarck. It, however, differs from them in having but 14 longitudinal muscle-strands instead of 21. It is perhaps more closely allied to *S. cumanensis*, but it has no dissepiments and no diverticulum of the alimentary canal.

This species is very long and slender. The largest specimens are between 21 and 22 cm. in length when fully extended, and vary from 1 cm. to 1.5 in breadth. Of this the introvert forms perhaps $\frac{1}{6}$. The skin is glistening grey, with certain blackish papillæ scattered over the surface (fig. 3); these, however, become closely and regularly arranged in rows on the proboscis. The cuticle has in many places separated from the underlying skin. The circular muscles are in rings with very numerous anastomoses. The head has numerous (some 40-60) short pointed tentacles which surround the excentrically placed mouth (fig. 1). The external opening of the anus is conspicuous (fig. 2), and the brown tubes open very slightly in front of it. The rectum is attached by numerous strands to the body-wall. The alimentary canal has many coils (30-40), and is not attached by any muscle-strands except at the posterior end, where there is a spindle-muscle running to the hind end of the body-wall.

The ventral retractors are very long, half as long as the body; they take their origin from the 2nd and 3rd longitudinal muscles, counting the muscle which lies next the nerve-cord as the 1st. The dorsal retractors are much shorter, not more than $\frac{2}{3}$, and some-

¹ Reisen im Archipel der Philippinen, II. Theil, iv. Band, 1 Abth. Wiesbaden, 1883.

times but $\frac{1}{2}$ as long as the ventral. They arise some distance in front of the ventral retractors. The ova are spherical.

This species is found fairly common under the thrown-up masses of coral-rock close to the edge of the reef.

3. SIPUNCULUS FUNAFUTI, n. sp. (Plate XXXVII. figs. 4 & 5.)

Numerous specimens from Funafuti.

These forms are from 5–8 cm. long, and 5 cm. broad; they taper at the posterior end into a sharp tail (fig. 4). All the specimens were limp and flabby when placed in my hands, but when immersed in water they became plump and regained their form. They are silvery white in colour and rather transparent. With one exception (fig. 4) the introvert is retracted, but this exception shows the circle of tentacles surrounding the mouth. The cuticle in many cases is separate from the skin, which bears scattered papillæ (fig. 5). The number of longitudinal muscles is 14 or 15 and there are few anastomoses. The two ventral retractors arise from two longitudinal muscles some way behind the two dorsal retractors, each of which has its origin in a single muscle. There are no hooks in the introvert, but the papillæ tend to range themselves in circular rows near the mouth. The intestine has few coils, 8–12, and is free but for the spindle-muscle attached to the tip of the tail. There are no diverticula. The brown tubes are small and free, they open at the same level as the anus.

The habitat of this species is the same as that of *S. vastus*, with which it is usually found.

4. PHYSCOSOMA NIGRESCENS Kef.

Several examples from Funafuti. The species extends through the Pacific and Indian Oceans to the Red Sea.

The members of this species and of the three following are found under the loosely massed rocks of the outer reefs, and also in tubes excavated in solid coral-rock.

5. PHYSCOSOMA PACIFICUM Kef. (Plate XXXVII. fig. 6.)

One specimen from Rotuma and numerous specimens from Funafuti. This species has previously been described from the Pacific and Indian Oceans and from the Red Sea.

The Rotuma specimen was without its head, and although the introvert was not fully extended it attained a length of 16 cm., considerably longer than any of the Funafuti specimens (fig. 6). The posterior sixth of the same specimen was curiously narrowed by the contraction of the circular muscles, so that a sort of tail, which bristles with the closely compressed papillæ, is formed. The brown tubes extend into this portion, which is traversed by the spindle-muscle, but the intestine does not extend into it.

6. PHYSCOSOMA SCOLOPS Sel. & de Man.

Several specimens of varying size, all with their introvert retracted, from Funafuti. This species also occurs at Singapore, the Philippines, and in the Red Sea.

7. *PHYSCOSOMA VARIANS* Kef.

One specimen from Funafuti. Selenka describes this species from several centres in the West Atlantic, but I have met with no mention of its occurrence in the Pacific Ocean.

8. *PHYSCOSOMA MICRODONTOTON* Sluit.¹ (Plate XXXVII. fig. 7.)

Several specimens from Funafuti and Rotuma.

Mr. Gardiner's specimens agree well with Sluiter's diagnosis of this species, except in the matter of size. Several of them are over 5 cm. in length, whereas Sluiter gives 1.5 cm. for the length of his Malayan forms; but as no reproductive organs were observed in his specimens, it is possible that they were immature forms. The gonads are very visible in the forms at my disposal at the base of the ventral muscles. In all other respects these specimens agreed with Sluiter's description.

9. *PHYSCOSOMA DENTIGERUM* Sel. & de Man.

Many specimens from Funafuti and Rotuma.

The species is very characteristic and easy to recognize from its large papillæ confined to the back of the introvert and trunk, and from its coloration. Selenka records it from the Philippines.

10. *ASPIDOSIPHON ELEGANS* Cham. & Eysenh. (Plate XXXVII. fig. 8.)

Seven specimens from Funafuti. Previously described from the Pacific, Philippines, and the Red Sea. Both this and the next named species were found in tubes bored in the dead coral of the reef.

11. *ASPIDOSIPHON KLUNZINGERI* Sel. & Bülow. (Plate XXXVII. fig. 9.)

One specimen from Funafuti. Previously described from Koseir.

The specimen had been injured and the alimentary canal and brown tubes protruded from a hole in the body-wall, and were broken: consequently it was impossible to see some of the characteristic features of this species. The shape of both anterior and posterior shields, the position and structure of the retractors, the number and shape of the longitudinal muscles left, however, little doubt that the specimen belonged to the species *A. klunzingeri* Sel. & Bülow.

12. *CLEOSIPHON ASPERGILLUM* Quatr. (Plate XXXVII. fig. 10.)

One specimen from Funafuti. Previously described from numerous localities in the Indian and Pacific Oceans.

The specimen is about 6 cm. in length, apparently a medium size, as those described by Sluiter² varied from 3.5 cm. to 7.5 cm.

¹ Beitr. z. d. Kenntniss der Gephyreen, IV. Mitth., Natuurk. Tijdschr. Nederl. Ind., Bd. xliii.

² Natuurk. Tijdschr. Nederl. Ind., Bd. xliii. p. 26.

Nevertheless there was no trace of calcareous deposit on the shield at the base of the introvert, around the spirally arranged papillæ of this part of the body.

13. *THALASSEMA CAUDEX* Lampert. (Plate XXXVII. fig. 11.)

Two specimens from Rotuma; also recorded from the Indian Ocean and the Red Sea.

Lampert¹ gives no details of the size of this species, except that it is very different in different specimens. The smaller of my two specimens measured just under 5 cm. from the mouth to the posterior end, and the length of the proboscis was 1.8. The corresponding measurements in the larger specimen were 7 cm. and 2.5. The last mentioned animal was very rotten and little could be made out of its internal anatomy; the six brown tubes were enormously distended and occupied a large portion of the body-cavity; presumably they were full of generative cells, but the animal was too decayed to determine this. In the other specimen the three pairs of brown tubes were normal, the anterior seemed to me to open between or just behind the pair of hooks, but this point could only be satisfactorily determined by sections.

The large specimen, in spirit, was a dirty brown; the small was olive-green in colour. The longitudinal bundles of muscles were clearly visible externally (fig. 11).

Lampert gives no figure, so I have added one.

This species was found under the growing coral near the outer edge of the reef.

14. *THALASSEMA VEGRANDE* Lampert. (Plate XXXVII. fig. 12.)

One specimen from Rotuma, also found in the Philippines.

Like Lampert I had only a single specimen, and, like his, mine had no proboscis. There was no trace of one and no scar to indicate that there ever had been one, and I am inclined to think that this species may be without a proboscis (fig. 12). The mouth is terminal and central, and but for the hooks there is no external indication as to which is the anterior end. The skin is thin and papery and so transparent as to allow the white and red fragments of coral in the intestine to shine through. No signs of longitudinal or circular muscles can be detected even with a lens. Numerous pigmented papillæ are scattered over the skin, and they become concentrated at the anterior end of the somewhat lemon-shaped body. The length of the body is 3.5 cm., the greatest breadth 1.4 cm.

Unfortunately the preserving fluids had not penetrated the body and the interior was in a sad state, and only traces of the brown tubes could be seen. Lampert says there are three pairs. The long brown anal tubes were left, but the alimentary canal had broken up in many parts, and the body-cavity was full of pieces of

¹ Zeitschr. wiss. Zool. Bd. xxxix. 1883, p. 334.



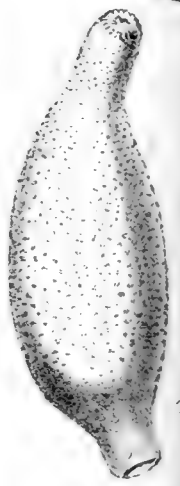
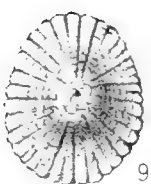
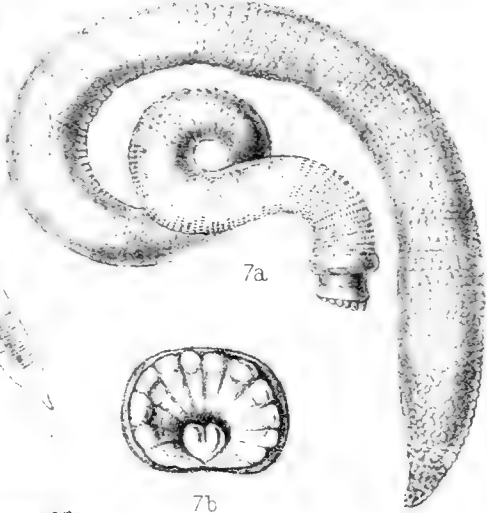
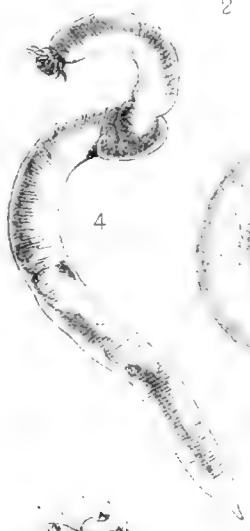
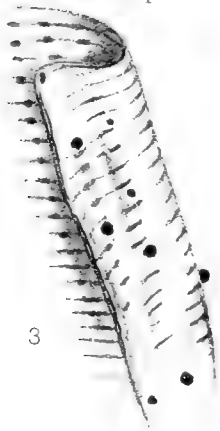
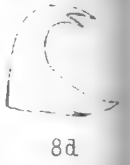
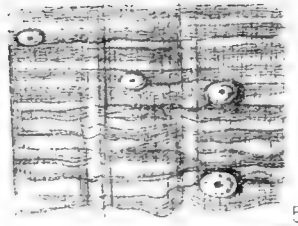
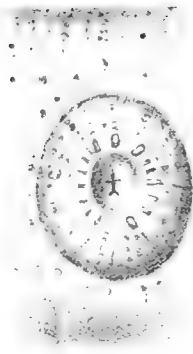
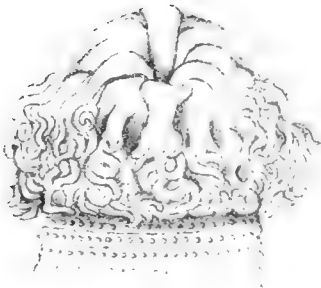

GEPHYREA FROM ROTUMA AND FUNAFUTI

shell and coral which had escaped from it. The ventral vessel and nerve-cord were conspicuous.

As only one specimen of this species has hitherto been described, it is peculiarly unfortunate that the state of preservation of the one I had precluded minuter investigation.

EXPLANATION OF PLATE XXXVII.

- Fig. 1. *S. rotumanus*, n. sp., p. 469. Head, $\times 4$.
 2. " " Anus and surrounding skin, $\times 4$.
 3. " " A portion of the skin to show the densely black papillæ and the arrangement of the circular muscles, $\times 4$.
 4. *S. funafuti*, n. sp., p. 470. The œsophagus in this specimen is slightly everted in the centre of the crown of tentacles. Nat. size.
 5. *S. funafuti*, n. sp. A piece of skin from the middle of the body showing the longitudinal and circular muscles and the scattered papillæ. Highly magnified.
 6. *Physcosoma pacificum* Kef., p. 470. The posterior narrow tail of the animal, showing the last loop of the intestine, the spindle-muscle, and the backward extension of the nephridia—black—to the extreme posterior end of the body. Nat. size.
 7. *Physcosoma microdontoton* Sluit., p. 471. *a.* Entire animal, $\times 4$. *b.* Head viewed *en face*, $\times 12$.
 8. *Aspidosiphon elegans* Cham. & Eysenh., p. 471. *a.* Entire animal, $\times 2$. *b.* Anus and anterior shield, $\times 5$. *c.* Posterior shield, $\times 10$. *d.* Hook, highly magnified.
 9. *Aspidosiphon klunzingeri* Sel. & Bülow, p. 471. *a.* Entire animal, $\times 2$. *b.* Posterior shield, $\times 4$. *c.* Anterior shield, $\times 4$.
 10. *Ctæosiphon aspergillum* Quatr., p. 471. *a.* Entire animal, $\times 2$. *b.* A few papillæ, more highly magnified.
 11. *Thalassema caudex* Lamp., p. 472. Ventral view, nat. size.
 12. *Thalassema vegrande* Lamp., p. 472. Ventro-lateral view, $\times 1\cdot5$.

3. Fourth Report on Additions to the Batrachian Collection in the Natural-History Museum.¹ By G. A. BOULENGER, F.R.S.

[Received May 17, 1898.]

(Plates XXXVIII. & XXXIX.)

Owing to the increasing attention paid by zoological collectors to this much neglected group of Vertebrates, the number of species of Tailless Batrachians represented in the National Collection is steadily rising. In the Second Report, published in 1890, I pointed out that the increase in the number of species of which specimens had been acquired has been at the rate of 10 per annum from 1858 to 1868, of 15 from 1868 to 1882, of 16 from 1882 to 1886, and of $18\frac{1}{2}$ from 1886 to 1890. It has risen to $19\frac{1}{4}$ from 1890 to 1894, and to $28\frac{1}{2}$ from 1898 to the present date, as shown by the following list.

A proportional increase in the additions to the collection of Tailed Batrachians is also observable on comparison with the previous lists.

¹ Cf. P. Z. S. 1894, p. 640.

The following table shows the number of species enumerated in the four Reports drawn up since the publication of the British Museum Catalogue of Batrachians in 1882:—

First Report (1886).	<i>Ecaudata</i> :	63.	<i>Caudata</i> :	4.	<i>Apoda</i> :	7.
Second „ (1890).	„	74.	„	3.	„	3.
Third „ (1894).	„	77.	„	2.	„	4.
Fourth „ (1898).	„	115.	„	10.	„	4.
	Total :	329.	„	19.	„	18.

I. *List of the Species, new or previously unrepresented, specimens of which have been added to the Collection since the last Report*¹.

(An asterisk indicates type specimens.)

ECAUDATA.

1. *Oxyglossus martensii* Ptrs.—Siam (*Siamese Mus.*).
2. *Rana leitensis* Bttgr. Zool. Anz. 1893, p. 365.—Sooloo Islands (*Everett*), Borneo (*Cator*), Celebes (*Everett*).
3. *Rana microdisca* Bttgr. Ber. Offenb. Ver. Nat. 1892, p. 137.—Celebes (*Sarasin*), Flores (*Everett*).
4. *Rana hascheana* Stol.—Great Natuna (*Everett*).
- *5. *Rana pulchra* Blgr. Ann. & Mag. N. H. (6) xviii. 1896, p. 468.—L. Tanganyika (*Nutt*).
6. *Rana ornata* Ptrs.—Gallaland (*Donaldson Smith*), Somaliland (*Bottego*).
7. *Rana newtoni* Bocage, Journ. Sc. Lisb. xlii. 1886, p. 70.—S. Thomé (*Moller*).
- *8. *Rana nutti* Blgr. Ann. & Mag. N. H. (6) xviii. 1896, p. 467.—L. Tanganyika (*Nutt, Moore*).
- *9. *Rana luzonensis* Blgr. op. cit. xvii. 1896, p. 401.—Luzon (*Whitehead*).
- *10. *Rana florensis* Blgr. op. cit. xix. 1897, p. 508.—Flores (*Everett*).
- *11. *Rana macrops* Blgr. P. Z. S. 1897, p. 233.—Celebes (*Sarasin*).
- *12. *Cornufer baluensis* Blgr. Ann. & Mag. N. H. (6) xvii. 1896, p. 449.—Borneo (*Everett*).
- *13. *Phrynobatrachus perpalmatus* Blgr. *infra*, p. 479.—L. Mweru, C. Africa (*Moore*).
- *14. *Oreobatrachus batuensis* Blgr. Ann. & Mag. N. H. (6) xvii. 1896, p. 401.—Borneo (*Everett*).
- *15. *Arthroleptis whytii* Blgr. P. Z. S. 1897, p. 802.—L. Nyassa (*Johnston*).

¹ In order to explain the inconsistencies that occur in the terminations of personal names, used to designate species, in the lists published by me in these 'Proceedings,' I wish to point out that these are due to editorial supervision, changes being made without my knowledge or consent.

- *16. *Arthroleptis bottegi* Blgr. Ann. Mus. Genova, (2) xv. 1895, p. 16.—Somaliland (*Bottego*).
- *17. *Arthroleptis minutus* Blgr. P. Z. S. 1895, p. 539.—Somaliland (*Donaldson Smith*).
- *18. *Arthroleptis noorii* Blgr. *infra*, p. 479.—L. Tanganyika (*Moore*).
- *19. *Mantidactylus majori* Blgr. Ann. & Mag. N. H. (6) xviii. 1896, p. 420.—Madagascar (*Forsyth Major*).
- 20. *Mantidactylus albofrenatus* F. Müller, Verh. nat. Ges. Basel, x. 1892, p. 197.—Madagascar (*Majastre, Forsyth Major*).
- *21. *Rhacophorus majori* Blgr. Ann. & Mag. N. H. (6) xvii. 1896, p. 404.—Madagascar (*Forsyth Major*).
- *22. *Rhacophorus moquardi* Blgr. t. c. p. 402.—Madagascar (*Majastre*).
- *23. *Rhacophorus peraccæ* Blgr. op. cit. xviii. 1896, p. 421.—Madagascar (*Forsyth Major*).
- *24. *Rhacophorus macroscelis* Blgr. op. cit. xvii. 1896, p. 404.—Borneo (*Everett*).
- *25. *Rhacophorus hosii* Blgr. op. cit. xvi. 1895, p. 169.—Borneo (*Hose*).
- *26. *Rhacophorus monticola* Blgr. op. cit. xvii. 1896, p. 395.—Celebes (*Everett, Sarasin*).
- *27. *Rhacophorus fasciatus* Blgr. op. cit. xvi. 1895, p. 169.—Borneo (*Hose*).
- *28. *Rhacophorus nigropalmatus* Blgr. t. c. p. 170.—Borneo (*Hose*).
- 29. *Rhacophorus brachychir* Bttgr. Zool. Anz. 1882, p. 480.—Madagascar (*Majastre*).
- 30. *Chiromantis verampelina* Ptrs.—Brit. E. Africa (*Ansorge, Betton*).
- *31. *Ixalus vittiger* Blgr. Ann. & Mag. N. H. (6) xix. 1897, p. 106.—Java (*Fruhstorfer*).
- *32. *Ixalus leitensis* Blgr. t. c. p. 107.—Leyte, Philippines (*Whitehead*).
- *33. *Ixalus mindorensis* Blgr. l. c.—Mindoro (*Whitehead*).
- 34. *Ixalus bimaculatus* Ptrs.—Borneo (*Everett*).
- 35. *Rappia thomensis* Bocage, Journ. Sc. Lisb. xlii. 1886, p. 74.—S. Thomé (*Moller*).
- 36. *Rappia quinquevittata* Bocage.—Stanley Falls.
- 37. *Rappia tristis* Bocage.—Lower Congo.
- *38. *Rappia molleri* Bedriaga, Amph. Rept. Guinée (1892), p. 10.—St. Thomé (*Moller*).
- 39. *Rappia rutenbergii* Bttgr.—Madagascar (*Greening*).
- *40. *Megalixalus brachyrenemis* Blgr. Ann. & Mag. N. H. (6) xvii. 1896, p. 404.—Nyassaland (*Johnston*).
- *41. *Megalixalus gramineus* Blgr. Ann. Mus. Genova, (2) xviii. 1893, p. 721.—L. Rudolf (*Bottego*).
- *42. *Hylambates johnstoni* Blgr. P. Z. S. 1897, p. 803.—Nyassaland (*Johnston*).

- *43. *Phyllobates infraguttatus* Blgr. op. cit. 1898, p. 118.—Ecuador (*Rosenberg*).
- 44. *Colostethus latinasus* Cope.—Colombia and Ecuador (*Rosenberg*).
- *45. *Oreophrynella quelchii* Blgr. Ann. & Mag. N. H. (6) xvi. 1895, pp. 125, 522.—Brit. Guiana (*Quelch*).
- 46. *Sphenophryne cornuta* Ptrs. & Doria.—New Guinea (*van Renesse*).
- *47. *Sphenophryne verrucosa* Blgr. Ann. Mus. Genova, (2) xviii. 1898, p. 707.—New Guinea (*Anthony*).
- *48. *Sphenophryne loriae* Blgr. l. c.—New Guinea (*Loria*).
- *49. *Sphenophryne ateles* Blgr. t. c. p. 708.—New Guinea (*Loria*).
- 50. *Sphenophryne biroi* Mchely, Term. Füzet. Budapest, xx. 1897, p. 411.—New Guinea (*Loria*).
- *51. *Sphenophryne anthonyi* Blgr. Ann. & Mag. N. H. (6) xix. 1897, p. 10.—New Guinea (*Anthony*).
- *52. *Sphenophryne monticola* Blgr. t. c. p. 508.—Lombok (*Everett*).
- *53. *Sphenophryne variabilis* Blgr. op. cit. xviii. 1896, p. 64.—Celebes (*Sarasin, Everett*).
- 54. *Calophrynus calcaratus* Mocq. Bull. Soc. Philom. (8) vii. 1895, p. 108.—Madagascar.
- *55. *Calophrynus brevis* Blgr. Ann. & Mag. N. H. (6) xvii. 1896, p. 403.—Madagascar (*Last*).
- *56. *Engystoma borneense* Blgr. op. cit. xix. 1897, p. 108.—Borneo (*Hose*).
- *57. *Microhyla palmipes* Blgr. l. c.—Java (*Fruhstorfer*).
- *58. *Microhyla bungurana* Gthr. Nov. Zool. ii. 1895, p. 501.—Great Natuna (*Everett*).
- *59. *Phryniculus oxyrhinus* Blgr. *infra*, p. 480.—St. Aignan Island, New Guinea (*Meek*).
- *60. *Mantophryne lateralis* Blgr. Ann. & Mag. N. H. (6) xix. 1897, p. 12.—New Guinea (*Anthony*).
- *61. *Mantophryne robusta* Blgr. *infra*, p. 480.—St. Aignan Island, New Guinea (*Meek*).
- *62. *Liophryne rhododactyla* Blgr. Ann. & Mag. N. H. (6) xix. 1897, p. 11.—New Guinea (*Anthony*).
- *63. *Liophryne brevis* Blgr. l. c.—New Guinea (*Anthony*).
- *64. *Xenorhina atra* Gthr. Nov. Zool. iii. 1896, p. 184.—New Guinea (*Day*).
- *65. *Dyscophus grandidieri* Blgr. Ann. & Mag. N. H. (6) xvii. 1896, p. 404.—Madagascar (*Last*).
- *66. *Hylodes anomalus* Blgr. P. Z. S. 1898, p. 119.—Ecuador (*Rosenberg*).
- *67. *Hylodes raniformis* Blgr. Ann. & Mag. N. H. (6) xvii. 1896, p. 19.—Colombia (*Rosenberg*).
- 68. *Hylodes ranoides* Cope, Proc. Amer. Philos. Soc. xxiii. 1886, p. 275.—Nicaragua (*Rothschuh*), Costa Rica (*Underwood*).

- *69. *Hylodes underwoodi* Blgr. Ann. & Mag. N. H. (6) xviii. 1896, p. 340.—Costa Rica (*Underwood*).
- *70. *Hylodes longirostris* Blgr. P. Z. S. 1898, p. 120.—Ecuador (*Rosenberg*).
- *71. *Hylodes achatinus* Blgr. l. c.—Ecuador (*Rosenberg*).
- *72. *Hylodes alfredi* Blgr. *infra*, p. 480.—Vera Cruz, Mexico (*Dugès*).
73. *Hylodes rugosus* Ptrs.—Nicaragua (*Rothschuh*).
- *74. *Hylodes gularis* Blgr. P. Z. S. 1898, p. 121.—Ecuador (*Rosenberg*).
- *75. *Hylodes discoidalis* Peracca, Boll. Mus. Torin. x. 1895, no. 195, p. 24.—Tucuman (*Turin Mus.*)
- *76. *Hylodes bufoniformis* Blgr. Ann. & Mag. N. H. (6) xvii. 1896, p. 19.—Colombia (*Rosenberg*).
- *77. *Hylodes latidiscus* Blgr. P. Z. S. 1898, p. 121.—Ecuador (*Rosenberg*).
- *78. *Hylodes erythropleura* Blgr. Ann. & Mag. N. H. (6) xvii. 1896, p. 20.—Colombia (*Rosenberg*).
79. *Hylodes cerasinus* Cope.—Costa Rica (*Underwood*).
80. *Hylodes polyptychus* Cope, Proc. Amer. Philos. Soc. xxiii. 1886, p. 276.—Nicaragua (*Rothschuh*), Costa Rica (*Underwood*).
- *81. *Syrhopus areolatus* Blgr. P. Z. S. 1898, p. 122.—Ecuador (*Rosenberg*).
82. *Ceratophrys cristiceps* F. Müller, Verh. nat. Ges. Basel, vii. 1883, p. 279.—Rio Janeiro (*Greening*).
- *83. *Paludicola borellii* Peracca, Boll. Mus. Torin. x. 1895, no. 195, p. 26.—Tucuman (*Turin Mus.*).
- *84. *Leptodactylus pulcher* Blgr. P. Z. S. 1898, p. 122.—Ecuador (*Rosenberg*).
- *85. *Leptodactylus maculilabris* Blgr. Ann. & Mag. N. H. (6) xvii. 1896, p. 404.—Costa Rica (*Underwood*).
- *86. *Borborocetes mexicanus* Blgr. *infra*, p. 481.—Zacatecas, Mexico (*Buller*).
- *87. *Chiroleptes dahlii* Blgr. P. Z. S. 1895, p. 687.—N. Australia (*Dahl*).
- *88. *Nectophryne macrotis* Blgr. Ann. & Mag. N. H. (6) xvi. 1895, p. 171.—Borneo (*Hose*).
- *89. *Nectophryne everetti* Blgr. op. cit. xvii. 1896, p. 450.—Borneo (*Everett*).
90. *Bufo penangensis* Stol.—Borneo (*Everett*).
91. *Bufo steindachneri* Pfeff. Jahrb. Hamb. Wiss. Anst. x. 1893, p. 103.—Gallaland (*Bottego*).
- *92. *Bufo dodsoni* Blgr. P. Z. S. 1895, p. 540.—Somaliland (*Donaldson Smith*).
- *93. *Bufo dombensis* Bocage, Journ. Sc. Lisb. (2) xiii. 1895, p. 50.—Angola (*Anchieta*).
94. *Bufo taitanus* Ptrs.—L. Tanganyika (*Nutt*), Somaliland (*Bottego*).

95. *Bufo coniferus* Cope.—Costa Rica (*Underwood*), Ecuador (*Rosenberg*).
96. *Bufo coccifer* Cope.—Costa Rica (*Underwood*).
- *97. *Hyla rosenbergii* Blgr. P. Z. S. 1898, p. 123.—Ecuador (*Rosenberg*).
98. *Hyla gabbi* Cope.—Costa Rica (*Underwood*).
99. *Hyla gratiosa* Leconte.—Florida (*Brimley*).
100. *Hyla puma* Cope, Proc. Amer. Philos. Soc. xxii. 1885, p. 183.—Costa Rica (*Underwood*).
- *101. *Hyla microcephala* Blgr. *infra*, p. 481.—Costa Rica (*Underwood*).
- *102. *Hyla variabilis* Blgr. Ann. & Mag. N. H. (6) xvii. 1896, p. 20.—Colombia (*Rosenberg*).
- *103. *Hyla rueppellii* Bttgr. Zool. Anz. 1895, p. 137.—Halmaheira (*Kükenthal*).
- *104. *Hyla fallax* Blgr. *infra*, p. 482.—New Guinea (*Doria*).
- *105. *Hyla everetti* Blgr. Ann. & Mag. N. H. (6) xix. 1897, p. 509.—Sumba, Savu, Ombai, Timor (*Everett*).
- *106. *Hyla impura* Ptrs. & Doria.—New Guinea (*Biro*).
107. *Nototrema bolivianum* Stdr. Sitzb. Ak. Wien, ci. 1892, p. 840.—Bolivia (*Rolle*).
- *108. *Nototrema angustifrons* Blgr. P. Z. S. 1898, p. 124.—Ecuador (*Rosenberg*).
- *109. *Nototrema cornutum* Blgr. l. c.—Ecuador (*Rosenberg*).
- *110. *Hyllella parabambæ* Blgr. t. c. p. 125.—Ecuador (*Rosenberg*).
- *111. *Hyllella puncticus* Blgr. Ann. & Mag. N. H. (6) xviii. 1896, p. 341.—Costa Rica (*Underwood*).
- *112. *Nyctimantis papua* Blgr. op. cit. xix. 1897, p. 12.—New Guinea (*Anthony*).
- *113. *Corythomantis greeningi* Blgr. op. cit. xvii. 1896, p. 405.—Espírito Santo, Brazil (*Greening*).
- *114. *Pelodytes caucasicus* Blgr. t. c. p. 406.—Caucasus (*Radde*).
- *115. *Leptobrachium natunæ* Gthr. Nov. Zool. ii. 1895, p. 501.—Great Natuna I. (*Everett*).

CAUDATA.

- *1. *Molge italica* Peracca, Boll. Mus. Torin. xiii. 1898, no. 317.—S. Italy (*Peracca*).
2. *Amblystoma talpoideum* Holbr.—Mississippi (*Brimley*).
- *3. *Amblystoma altamirani* Dugès, Natureza, ii. 1896, p. 459.—Mexico (*Dugès*).
4. *Amblystoma annulatum* Cope, Proc. Amer. Philos. Soc. xxiii. 1886, p. 525.—Arkansas (*Brimley*).
5. *Autodax iecanus* Cope, Proc. Ac. Philad. 1883, p. 24.—California (*Gilbert, Van Denburgh*).
- *6. *Spelerpes subpalmatus* Blgr. Ann. & Mag. N. H. (6) xviii. 1896, p. 341.—Costa Rica (*Underwood*).
7. *Spelerpes bocourti* Brocchi, Miss. Sc. Mex., Batr. p. 111 (1882).—Costa Rica (*Underwood*).

8. *Spelerpes altamazonicus* Cope.—Colombia (*Pratt*).
 *9. *Desmognathus brimleyorum* Stejn. Proc. U.S. Nat. Mus. xvii. 1895, p. 597.—Arkansas (*Brimley*).
 *10. *Typhlomolge rathbuni* Stejn. op. cit. xviii. 1896, p. 620.—Texas (*U.S. Nat. Mus.*).

APODA.

1. *Hypogeophis alternans* Stejn. Proc. U.S. Nat. Mus. xvi. 1894, p. 739.—Seychelles (*Paris Mus.*).
 *2. *Bdellophis vittatus* Blgr. P. Z. S. 1895, p. 412.—German E. Africa (*Werner*).
 *3. *Boulengerula boulengeri* Tornier, Thierw. O.-Afr., Rept. Amph. p. 164 (1896).—German E. Africa (*Berlin Mus.*).
 4. *Siphonops brasiliensis* Rhdt.—Sta. Catharina (*Prague Museum*).

II. *Descriptions of new Species.*

1. PHRYNOBATRACHUS PERPALMATUS. (Plate XXXVIII. fig. 1.)

Tongue with a conical median papilla. Habit ranoid. Head small; snout short, subacuminate, without canthus; interorbital space convex, a little narrower than the upper eyelid; tympanum feebly distinct, two thirds the diameter of the eye. First finger not extending quite so far as second; toes entirely webbed, with very slightly swollen tips; subarticular tubercles small; two small metatarsal tubercles and a third tubercle in the middle of the inner edge of the tarsus. The tibio-tarsal articulation reaches the eye, the tarso-metatarsal a little beyond the tip of the snout. Skin feebly warty above. Brown above, with small dark spots; a dark, light-edged streak on each side from the eye to the groin, involving the tympanum; a dark cross-bar on the thigh and another on the tibia; hinder side of thighs white, with a wavy blackish band; lower parts white, throat with some brown dots; two brown streaks or series of spots on the lower surface of the thighs.

Total length 22 millim.

Two specimens were obtained about Lake Mweru by Mr. J. E. S. Moore on his expedition to Lake Tanganyika.

2. ARTHROLEPTIS MOORII. (Plate XXXVIII. fig. 2.)

Tongue with a conical median papilla. Head moderate, as long as broad; snout rounded, as long as the eye; nostril nearer the end of the snout than the eye; interorbital space as broad as the upper eyelid; tympanum indistinct, two thirds the diameter of the eye. First and second fingers equal, more than half as long as third; toes webbed at the base, tips slightly swollen; subarticular tubercles small; two very small metatarsal tubercles, and a third tubercle in the middle of the inner edge of the tarsus. The tibio-tarsal articulation reaches the tip of the snout. Skin smooth. Olive above; a triangular dark spot, the apex turned backwards, between the eyes; a **Λ**-shaped dark marking

between the shoulders, and dark bars across the limbs; lower parts white.

From snout to vent 20 millim.

A single specimen from Kinyamkolo, Lake Tanganyika (*J. E. S. Moore*).

3. *PHRYNIXALUS OXYRHINUS*. (Plate XXXVIII. fig. 3.)

Tongue oval, rather narrow, free in its posterior third; palatine ridges strong. Head as long as broad; snout pointed, very prominent; nostril a little nearer the end of the snout than the eye; canthus rostralis rounded; loreal region almost vertical; interorbital space twice as broad as the upper eyelid; tympanum vertically oval, about three fourths the size of the eye. Fingers and toes dilated into small but well-developed disks; subarticular tubercles feebly prominent; first finger shorter than the second; a feebly prominent, oval inner metatarsal tubercle. The tibio-tarsal articulation reaches the eye. Skin smooth. Pale grey above, with dark brown spots and marblings, which are largest on the sides; sides of head dark brown; groin and hinder side of thighs whitish, with black spots or marblings; white beneath.

From snout to vent 28 millim.

Five specimens from St. Aignan I., south of Fergusson I., British New Guinea; collected by Mr. Meek.

4. *MANTOPHYRNE ROBUSTA*. (Plate XXXVIII. fig. 4.)

Habit stout. Head subtriangular, much broader than long; snout obtusely pointed, prominent, shorter than the diameter of the orbit; canthus rostralis indistinct; loreal region oblique, slightly concave; nostril nearer the tip of the snout than the eye; interorbital space as broad as the upper eyelid; tympanum about two thirds the diameter of the eye. Fingers and toes rather short, with small terminal disks and feebly prominent subarticular tubercles; first finger a little shorter than the second; a feebly prominent, oval inner metatarsal tubercle. The tibio-tarsal articulation reaches the shoulder or the tympanum. Skin smooth, shiny; a strong fold from the eye to the shoulder. Reddish or purplish brown above, uniform or with small black spots; lower parts pale brown.

From snout to vent 71 millim.

Three specimens from St. Aignan I., south of Fergusson I., British New Guinea; collected by Mr. Meek.

5. *HYLODES ALFREDI*. (Plate XXXIX. fig. 1.)

Tongue subcircular, entire or indistinctly nicked behind. Vomerine teeth in two short transverse groups behind the level of the choanæ. Head much depressed; snout short, rounded; nostril near the tip of the snout; canthus rostralis distinct; loreal region concave; interorbital space as broad as the upper eyelid; tympanum very distinct, two thirds the diameter of the eye. First finger a little shorter than second; disks of fingers large,

truncate, subtriangular, their diameter nearly equalling that of the tympanum; toes free, the disks a little smaller than those of the fingers; subarticular tubercles moderately large, very prominent; two small metatarsal tubercles. The tibio-tarsal articulation reaches the tip of the snout. Skin smooth above and beneath. Greyish above, speckled with blackish, white beneath.

From snout to vent 36 millim.

Two specimens from Atoyac, State of Vera Cruz. Presented by Dr. Alfred Dugès, after whom the species is named.

6. *BOBBOROCETES MEXICANUS*. (Plate XXXIX. fig. 2.)

Tongue oval, entire. Vomerine teeth in two rounded groups behind the level of the choanæ. Snout rounded, a little longer than the diameter of the orbit; nostril nearer the end of the snout than the eye; canthus rostralis rounded; interorbital space a little broader than the upper eyelid; tympanum distinct, two thirds the diameter of the eye. Fingers moderate, first extending beyond second; toes moderate, free; subarticular tubercles of fingers and toes very strong; a large and very prominent, compressed inner metatarsal tubercle and a small, rounded outer metatarsal tubercle. The tibio-tarsal articulation reaches between the eye and the nostril. Skin smooth. Olive-grey above, with small darker markings; a dark cross-bar between the eye; a dark lumbar marking; a dark streak on each side of the head and body, not reaching the groin; lips with vertical dark bars; limbs with dark cross-bars; lower parts white; sides of throat speckled with brown.

From snout to vent 37 millim.

Two specimens from Hacienda el Florencio, Zacatecas, Mexico; collected by Dr. A. C. Buller.

7. *HYLA MICROCEPHALA*. (Plate XXXIX. fig. 3.)

Tongue circular, slightly nicked, and moderately free behind. Vomerine teeth in two small round groups between the choanæ. Head small, a little broader than long; snout rounded, as long as the diameter of the orbit; canthus rostralis distinct; loreal region slightly oblique; interorbital space broader than the upper eyelid; tympanum distinct, half the diameter of the eye. Fingers one-third webbed; no projecting rudiment of pollex; toes nearly entirely webbed; disks quite as large as the tympanum; subarticular tubercles moderate. The tibio-tarsal articulation reaches between the eye and the tip of the snout. Skin smooth above and on the throat, granular on the body. Pale brown above, uniform or with scattered dark brown dots; a dark brown streak on each side of the head and belly, passing through the eye and edged with whitish above; thighs pigmentless; white beneath. Male with a large external vocal sac.

From snout to vent 28 millim.

Two specimens, male and female, from Bebedero, Costa Rica; collected by Mr. Underwood.

Nearest allied to *H. uranochroa*, Cope.

8. *HYLA FALLAX*. (Plate XXXIX. fig. 4.)

Tongue circular, slightly nicked and free behind. Vomerine teeth in two small round groups on a level with the posterior borders of the choanæ. Head moderate, broader than long; snout rounded, as long as the diameter of the orbit; canthus rostralis indistinct; loreal region very oblique; interorbital space broader than the upper eyelid; tympanum distinct, half the diameter of the eye. Outer fingers almost half-webbed; no projecting rudiment of pollex; toes nearly entirely webbed; disks nearly as large as the tympanum; subarticular tubercles feeble. The tibio-tarsal articulation reaches between the eye and the tip of the snout. Skin smooth above and on the throat, granular on the belly. Dark purplish-brown above, with white markings, viz. a broad triangular blotch on the forehead, extending on the anterior half of the upper eyelid, a band on each side of the back, from the upper eyelid to the sacral region, and a subtriangular blotch on the coccygeal region; these markings enclosing a vase-shaped area of the ground-colour; a white blotch above the heel, and some white dots on the tibia.

From snout to vent 27 millim.

A single specimen from Katow, New Guinea; received from the Marquis G. Doria.

This tree-frog bears a striking superficial resemblance to the South-American *H. leucophyllata*, Beiris.

EXPLANATION OF THE PLATES.

PLATE XXXVIII.

- Fig. 1. *Phrynobatrachus perpalmatus*, p. 479.
 2. *Arthroleptis moorii*, p. 479.
 3. *Phrymixalus oxyrhinus*, p. 480.
 4. *Mantophryne robusta*, p. 480.

PLATE XXXIX.

- Fig. 1. *Hylodes alfredi*, p. 480.
 1 a. " " Open mouth.
 2. *Borborocates mexicanus*, p. 481.
 2 a. " " Open mouth.
 3. *Hyla microcephala*, p. 481.
 4. " *fallax*, p. 482.

4. Note on an Italian Newt, *Molge italica*.

By M. G. PERACCA, Ph.D., F.Z.S.

[Received May 31, 1898.]

(Plate XL.)

I have recently described¹ a new Italian Newt discovered by me in the southern part of Italy. The kind permission of the Zoological Society to have this Newt figured in the Proceedings

¹ Boll. Mus. Zool. Anat. Comp. n. 317, 14 Maggio, 1898, vol. xiii.



2.

3.

1.

4.





3.



4.



1a.



2a.



1.



2.





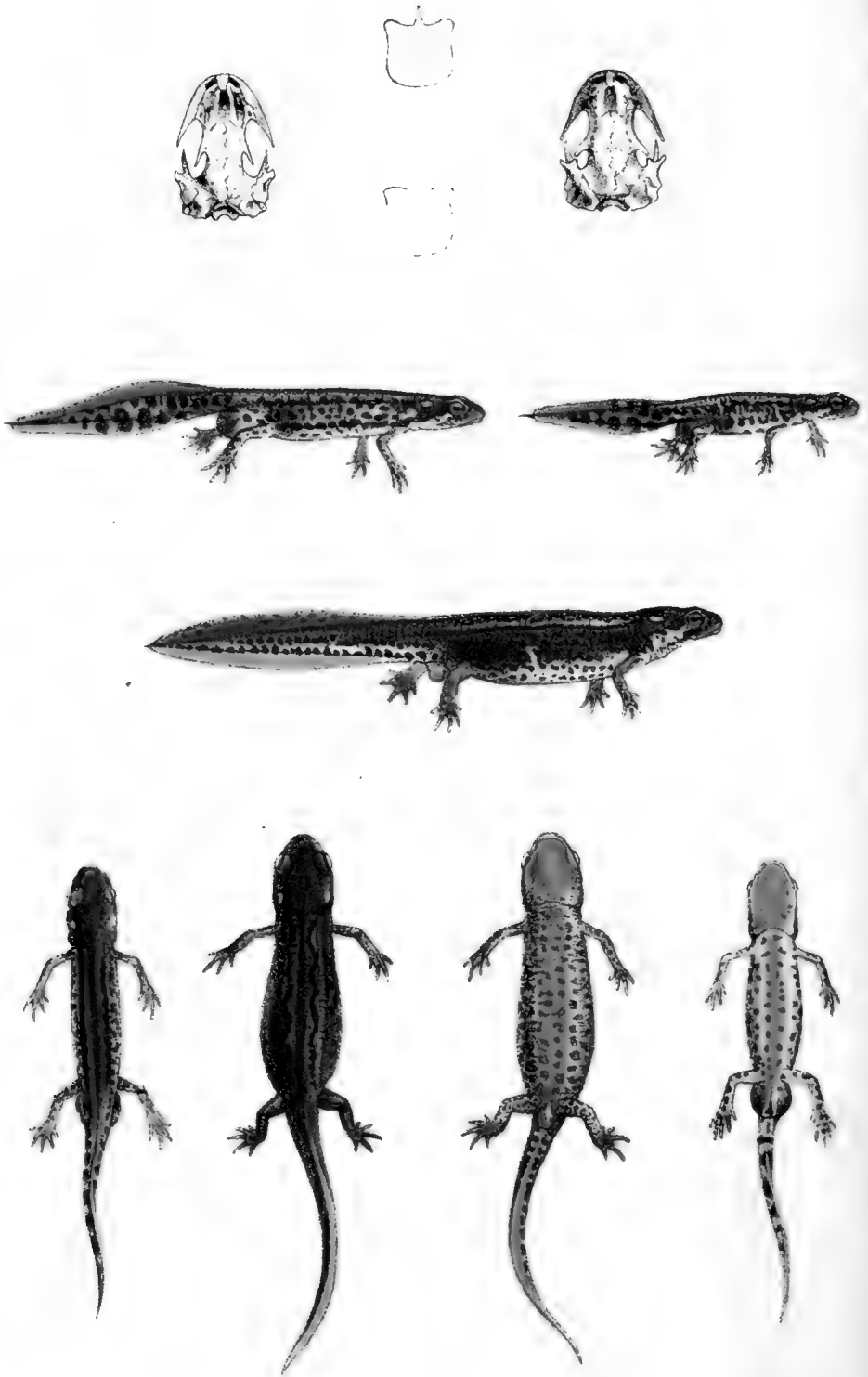

P.J.Smit del. et lith.

Mintern Bros. Chrom.

MOLGE ITALICA

gives me the opportunity of making my new species better known and to add something to my previous remarks. Specimens are also now exhibited in the Society's Reptile-house.

MOLGE ITALICA Peracca. (Plate XL.)

Triton teneosus (partim), H. Giglioli, "Elenco dei Mammiferi, degli uccelli e dei Rettili ittiofagi appartenenti alla fauna italiana e Catalogo degli Anfibi e dei Pesci italiani" (estratto del Catalogo generale della sezione italiana alla Esposizione internazionale della pesca in Berlino, nell' anno 1880) (spec. of Palizzi).

Triton vulgaris, subsp. *meridionalis* (partim), Camerano, Monografia Anfibi urodela italiani, 1884, Mem. Reale Acc. delle Scienze di Torino, ser. ii. tom. xxxvi. (spec. of Campobasso).

Fronto-squamosal arch partially ligamentous; frontals with well-developed, thick, orbital processes. Palatine teeth in two series in contact or hardly separated anteriorly, then gradually diverging behind; the two diverging branches often somewhat curved inwardly; these series commencing on a line with the choanæ.

Tongue small, elliptical, free along the sides (as in *M. vulgaris*). Head thick, swollen in the parotoid region, longer than broad, once and a fifth as long as wide, contained thrice in the length of the body. The greatest width of the head at the centre of the eyes in the males, at the commissures of the mouth in the females. Upper surface of the head slightly convex, but nearly in a straight line seen from the side; a short and hardly defined groove on the ethmoidal region; no lateral grooves. Snout thick, short, obtuse, with ill-defined canthus rostralis, broadly convex between the eyes and the end of the snout. Eyes slightly prominent, especially in the males, the longitudinal diameter of which equals the distance between the anterior corner of the eyes and the nostril. Interorbital space contained twice and two-thirds, never thrice, in the length of the head. Labial lobes well developed during the breeding-season, very much developed in old females. Body quadrangular in the breeding male, with a more or less developed cutaneous fold bordering each side, without dorsal crest and subquadrangular in the female, with a distinct median dorsal groove in both sexes. Limbs moderate; the fore limb stretched forwards extends just beyond the tip of the snout in the males and hardly reaches the tip of the snout in some females.

When the limbs are adpressed, the third finger in the male overlaps the outer tarsal tubercle, in the female it hardly reaches the base of third toe. The length of the fore and hind limbs is the same in both sexes. Fingers and toes moderate, depressed; the latter in the male often with rudimentary web at the base. Two small, but very distinct, conical carpal and tarsal tubercles, the outer of which, especially the tarsal, is more prominent. Tail strongly compressed in the breeding-season, a little longer than head and body in the male, equalling head and body in the female, with an upper and a lower crest. The height of the tail is less in the

male, and its borders are distinctly convergent towards the end, while in the female they are nearly parallel. The end of the tail is broadly rounded and sharply mucronated. Cloaca of the male a longitudinal cleft, with strongly swollen lips (as in *M. vulgaris*); that of the female like that of *M. vulgaris*, but smaller, more compressed, subconical, and directed inwardly in the specimens preserved in spirit. Skin nearly smooth or minutely tuberculated, with a network of faint nearly transverse grooves and ten to twelve vertical more or less conspicuous costal grooves on the sides of the body and vertical ones on the sides of the basal portion of the tail. Upper surface of head with two diverging series of conspicuous pores. A distinct gular fold, sometimes undistinguishable in the preserved specimens.

Male. Upper surface of head and body between the two cutaneous folds olive-brown, more or less dark, with small darker spots irregularly disposed; head neither spotted nor striped, sometimes minutely speckled with dark brown on the sides. Upper lip dark. Flanks of a beautiful metallic brass-yellow, with scattered large dark olive-brown spots, sometimes with lead-grey centres. The metallic brilliancy of the flanks may be obscured with dark brown or lead-grey speckles. Sides of the tail usually brass-yellow in the basal half, the distal half, when not metallic, being yellow-brown, minutely speckled with brown and metallic dots. The lower border of the tail yellowish white. The tail is marked with large brown, sometimes lead-grey, spots and a few large black ones are constantly to be seen on its lower basal border. From the lower part of the head, beginning from the posterior corner of the eye, along the flanks to the vent a white or yellowish-white, usually unspotted, narrow band, with silky gloss, which extends more or less, during the breeding-season, on the lateral parts of the belly. Throat yellow-ochre, more or less dark, unspotted or with scattered black dots towards the gular fold and the sides; belly yellow-ochre, always lighter than the throat, with numerous small black roundish spots irregularly disposed or sometimes confined to the sides of the belly. The swollen lips of the cloaca brass-yellow or glossy white, with large black spots; the lips of the anal cleft blackish slate-grey. Upper surface of limbs, fingers, and toes olive-brown, with dark dots; lower parts yellowish or whitish; the soles yellowish or dark grey.

Female. The throat and the belly are as in the males, but the lateral black dots on the belly are very often transversely expanded or more or less curved to form incomplete rings. Upper parts and sides of the tail olive-brown, more or less darker, very often minutely speckled with lead-grey. On the back along the lateral folds there are black spots often confluent to form a festooned band, as in the females of *M. vulgaris*, *palmata*, *montandoni*. Sides of the tail with round black spots, usually disposed along an upper and a lower line; lower crest yellow-ochre.

Some females are very brilliantly coloured, with metallic flanks, like the males. Both in the males and females there is a yellow

or metallic-yellow roundish spot, nearly constant in all specimens, on the temporal region. Iris, in breeding specimens, golden, shining, crossed by a transverse blackish-brown band.

In the specimens on land the tail loses its crest, the end becomes very shortly mucronated, and the male is no longer distinguishable from the female. The flanks in the male lose their brilliant appearance and become dark olive or grey-brown, minutely speckled with slate-grey or light brown like the upper parts, on which the dark dots and, usually, two lateral blackish festooned lines, as in the female, become very conspicuous.

Measurements.

	Potenza.		Lecce (St. Cataldo).	
	♂. mm.	♀. mm.	♂. mm.	♀. mm.
Total length	61	74	46	50
From snout to the anterior border of the vent.....	27	37	22	25
Length of the head (to the occiput)..	8	10	6	7
Width of the head	6	7	5	5
Fore limb	11	12	8	8
Hind limb	11	12	8	8
Tail.....	34	37	24	25
Height of the tail	6	8	5	5

This species was discovered by me this year in the beginning of March near Potenza in the Basilicata (822 m. above sea-level), where I found it very common in all pools, reservoirs, and ditches along the Basente river, in which the water is sometimes slowly running. In some deep wells I found numerous larvæ, which evidently were about a year old and had spent the winter in the water. I am not able to state, at present, whether these larvæ present the true facies of such as perform their regular annual cycle of development till the metamorphosis. They resemble very much in general shape and coloration those of *M. alpestris*. I think that a further investigation will perhaps prove that the larva of *M. italica* may be intermediate between that of *M. alpestris* and *M. vulgaris*.

I hope to be able to give later on a full description of the larvæ which are now developing in my aquarium.

Among the larvæ collected at Potenza I found some gigantic gill-breathing specimens, which a careful examination proved to be adult. All were provided with a low dorsal crest, beginning nearly above the insertion of the gills. Most of them were females with perfectly developed eggs; among the males I found one with conspicuously developed gills, swollen lips of the cloaca, and showing the size and the characteristic brilliant metallic coloration of fully metamorphosed adult breeding males. This fact proves that *M. italica*, at least in the mountain district of Potenza, is

able to reach the fully adult and breeding state without metamorphosing, as is known to be the case in *M. alpestris*.

I met with *M. italica* also at St. Cataldo (12 k. from Lecce) on the sea-shore, where it seems to be confined to the freshwater marshes running at a short distance along the coast of the Adriatic from Brindisi to Taranto. Curiously enough, I never found it in the reservoirs or tanks in the gardens near Lecce.

The specimens from St. Cataldo are remarkable by their extraordinary small size, being nearly half that of specimens from Potenza. Perhaps the fact is due to the early drying up of the marshes in the summer, so that the development of the larvæ becomes more rapid and they do not attain their full typical size.

A very badly preserved female specimen, labelled *M. vulgaris*, from Campobasso, Molise, is in the collection of the Turin Museum, but a careful examination proves that it belongs to my new species.

Prof. H. Giglioli, in his "Elenco dei Mammiferi, degli uccelli e dei Rettili ittiofagi appartenenti alla fauna italiana e Catalogo degli Anfibi e dei Pesci italiani" (estratto del Catalogo generale della sezione italiana alla Esposizione internazionale della pesca in Berlino, nell' anno 1880), at page 15 mentions *Triton taeniatus* (= *M. vulgaris*) from Palizzi, near Gerace, Calabria.

Through the kindness of Prof. Giglioli, who, at my request, sent me the Palizzi specimens, I am now able to state that they are, as I had already hinted in my former paper, true *M. italica*. There are four specimens, all females, which were collected in June 1878 by Prof. G. Cavanna. The strong spirit used in preserving them has caused their teguments so to contract that the back shows, instead of a groove, a kind of longitudinal produced ridge due to the prominence of the vertebral column. Their size equals that of the specimens from Potenza, although Palizzi stands at no great elevation above sea-level.

Molge italica has an extensive range in the peninsula, as it seems to inhabit the whole of south-eastern Italy, while *M. vulgaris*, subsp. *meridionalis*, seems not to have as yet been found south of a line connecting Ancona to the Gran Sasso d'Italia and extending to Naples¹, south of which we are not acquainted with the presence of this species².

From what we know at present, *Molge italica* exists in Molise (Campobasso), in Basilicata (Potenza), in Terra d'Otranto (near Lecce), very probably in Capitanata, and in Calabria, along or at a short distance from the coasts of the Ionic Sea (Palizzi); but it does not seem to be found in the interior of Calabria, at least I was not able to discover any trace of it at Cosenza, at Catanzaro Sala, and on the elevated plateaus of Aspromonte (about 1200 m. above sea-level), where pools and marshes are frequent and in which the

¹ Dr. Wolterstorff, of Magdeburg, recently informed me he had received some specimens of *M. vulgaris* from Naples.

² I did not succeed in March past in discovering it in the plains of Salerno.

water lasts for a long time in the summer. The fishermen and country people of the mentioned localities appeared to me not to be acquainted with the animal.

Molge italica is very closely allied by the structure of its skull both to the typical *M. vulgaris* and subsp. *meridionalis*. The skull of *M. italica* is stouter, the interorbital space is constantly larger than in *M. vulgaris*, being contained twice and two-thirds, never thrice (as in *M. vulgaris*), in the length of the skull. The fronto-orbital processes are more developed, being longer, stouter, and directed more outwardly than in *M. vulgaris*. The ligamentous portion of the fronto-squamosal arch is more reduced here, so that we may consider *M. italica* as a true transitional form between *M. vulgaris* and the allied species with the fronto-squamosal arch bony.

The new species is easily recognizable from its allies, both from the species with a dorsal crest (*M. vulgaris*, *palmata*) or those without (*M. boscae*, *montandoni*), by the presence in both sexes of a well-marked dorsal longitudinal groove, while even in the allied species without dorsal crest both the males and females are provided with a straight and low cutaneous dorsal ridge¹.

The excellent Plate, drawn by Mr. Smit, under the kind supervision of my friend Mr. Boulenger, to both of whom I beg to tender my best thanks, shows so well the characters of the species that I need not insist on other differences in the coloration which can be easily noticed between *M. italica* and its allies.

5. On some Spiders from Savoy. By the Rev. O. PICKARD-CAMBRIDGE, M.A., F.R.S., C.M.Z.S., &c.

[Received May 13, 1898.]

A small collection of Spiders made for me at the Chalet de Mëlèzes, near St. Gervais les Bains, Haute-Savoie, in July and August 1894, by Mr. A. W. Pickard-Cambridge, with others made in August 1896 and July 1897, contained examples of thirty-two species, one of which (of the genus *Gnaphosa*) appears to me to be undescribed. Another species, *Lycosa* (*Pardosa*) *riparia* C. L. Koch, is of great interest, as little seems to be known of it. M. Simon, in his great work on French Spiders, describes under that name a totally distinct form. Dr. Ludwig Koch has kindly sent me a reliable type of the true *L. riparia*, by which I have been able to determine the examples in the present collection.

Subjoined is a list of the species, with descriptions of the new *Gnaphosa* and of the *Lycosa riparia*.

¹ See the outlines of the body in the mentioned species given by Boulenger in his "Description d'une espèce nouvelle de Triton," Bull. Soc. Zool. France, 1880, pl. vii.

List of Species.

ARACHNIDA - ARANEIDEA.

DRASSIDÆ.

- Callilepis nocturna* Linn. Adult male.
Gnaphosa molesta, sp. n. Adult females.
Drassus troglodytes C. L. Koch. Adult females.
 „ *cupreus* Bl. Adult female.
 „ *lapidicolens* Walck. Adult and immature females.
Prothesima latreillii L. Koch. Adult female.
 „ *nigrita* Pall. Adult female.
Micaria pulicaria Sund. Adult female.

THERIDIIDÆ.

- Erigone dentipalpis* Wid. Adult males.
Tmeticus fortunatus Cambr. Adult male.—This is only the second record of this very distinct species. See Proc. Dorset Nat. Hist. and Antiq. Field-Club, 1895, vol. xvi. p. 123, pl. A. fig. 6.
Linyphia pusilla Sund. Adult female.
Microneta fuscipalpis C. L. Koch. Adult male.

EPEIRIDÆ.

- Epeira diademata* Clk. Adult males and immature females.
 „ *quadrata* Clk. Adult male and females.
 „ *ceropegia* Walck. Adult male and female.
Zilla alpina L. Koch. Female, immature.

THOMISIDÆ.

- Xysticus gallicus* Sim. Adult males and females.
 „ *cristatus* Clk. Adult male.
Philodromus alpestris L. Koch. Adult female.

LYCOSIDÆ.

- Tarentula andrenivora* Clk. Adult males.
 „ *pulverulenta* Clk. Adult male and female.
 „ *nemoralis* Westr. Adult male.
Trochosa leopardus Sund.
Lycosa amentata Clk.
 „ *cursoria* C. L. Koch. Adult male and female.
 „ *albata* L. Koch.
 „ *palustris* Linn. Adult males and females.
 „ *blanda* C. L. Koch. Adult males and females.
 „ *riparia* C. L. Koch. Adult males and females. Alt.
 5000 to 7000 feet.
Pirata latitans Bl.

SALTICIDÆ.

- Attus pictilis* E. Sim. Adult male.
Epilemum scenicum Clk. Adult female.
 Several females of *Erigonini* were also in the collection, but in the absence of males the species are uncertain.

Descriptions of two Species.

GNAPHOSA MOLESTA, sp. n. (Figs. 1, 2.)

Adult female, length 3 lines (6 mm. nearly).

In general form, colours, and markings this spider closely resembles *Gnaphosa anglica* Cambr., but is much smaller, the female of that species commonly measuring 4 lines in length. The present spider is also much less hirsute, the fine prominent hairs covering the whole spider being fewer and shorter.

Fig. 1.

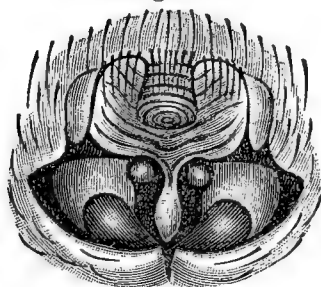

Fig. 2.

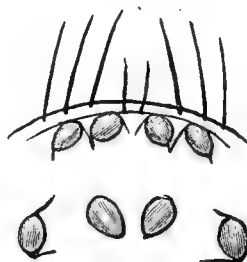

Fig. 1.—*Gnaphosa molesta*: epigyne (♀).

Fig. 2.— " " (♀): eyes from above and a little behind.

The cephalothorax, legs, falces, and palpi are of a yellow-brown ground-colour, the cephalothorax somewhat dusted with dark brown and having a strong V-shaped darker marking at the hinder end of the caput, also some dark converging irregular lateral lines on the thorax and a strongish marginal black-brown line. The legs have the femora dusted with dark brown, leaving some patches immaculate, and beneath the fore extremity of the tibiæ of the first and second pairs is a single spine, which I cannot observe in *G. anglica*.

The *maxillæ*, *labium*, and *sternum* are dark yellow-brown.

The position of the eyes is almost exactly similar in both species.

The *abdomen* is dark greyish-mouse-black and its hairy clothing short and close. The genital aperture somewhat resembles that of *G. anglica*, but the anterior obtuse process directed backwards is distinctly shorter.

This spider is possibly *G. leporina* of L. Koch, of which I have not been able to examine any authentic example, and it is less hazardous to describe it as new than to include it from the description alone as synonymous with at any rate a very nearly allied spider. M. Simon some years ago singled out a female from a lot of *G. anglica* I sent to him for examination, as a female of *G. leporina* L. Koch. I have re-examined this specimen very carefully and it is certainly only *G. anglica*. It did not appear that M. Simon had ever seen an authentic example of *Gnaphosa leporina* L. Koch, which has not yet been recorded from France, its localities being given as Transylvania, Germany, and Sweden.

Adult females were found at the Chalet Mélézes near St. Gervais

les Bains, near the end of July 1897, and again in August 1896. From this sex being not rare under stones, mostly with their egg-sacs, and no males being seen, it is probable that the season for the latter sex had passed.

LYCOSA (PARDOSA) RIPARIA C. L. Koch. (Figs. 3, 4.)

Adult male, length $2\frac{1}{2}$ lines (nearly 5 mm.).

In form, size, colours, and markings this spider closely resembles *L. pullata* Clk., so much so that M. Simon, to whom I submitted both sexes for examination, returned them to me under that name. Had M. Simon, however, closely inspected the male palpi and the female genital organs he would at once have seen their great difference from those of *L. pullata*.

Fig. 3.

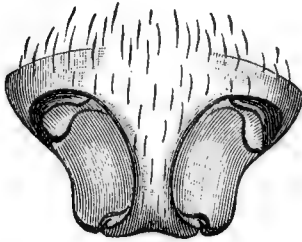

Fig. 3.—*Lycosa riparia*: epigyne (♀).

Fig. 4.

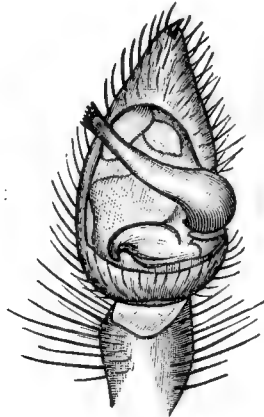

Fig. 4.— „ „ (♂): portion of palpus and palpal organs.

Cephalothorax deep brown, with three longitudinal yellow stripes or narrow bands—a central, two lateral, and a submarginal: the lateral stripes are rather irregular; the central stripe terminates at the beginning of the ocular area, and is rather broader in the middle than at the ends. Ocular area black.

Legs yellow, the femora more or less clouded and marked irregularly with deep brown and blackish; those of the fourth pair longest.

Palpi black, the radial and digital joints thickly clothed with short strong hairs; those of the outer side of the digital joint shortest and of uniform length. This joint is rather longer than the radial and cubital joints together, narrow-oval, and ending with a strongish, curved, nail-like claw. The palpal organs are highly developed. From the usual large basal lobe a long, strong, broad, curved, spiny, tapering, somewhat flat strap-like process on the inner side curves over obliquely to the outer side, a little beyond which its broadly and a little obliquely obtuse point projects freely; this point

is furnished with a few minute denticles or granulations. From beneath the base of this long curved process springs a small black, curved, sharp-pointed spine having the same general direction as the process. At the base of the palpal organs is a short, black, prominent, curved, corneous point rather directed backwards.

Abdomen dark blackish brown, much obscured by grey hairs; the markings in this sex almost obsolete, but resembling apparently those of the female.

The *female* is slightly larger than the male. The legs have the femora, tibiæ, and (at least in one example) the metatarsi more or less, but not distinctly, annulated with brown; in another example the metatarsi were immaculate. The abdomen is clothed, principally on the sides and underneath, with greyish hairs; the upperside is slightly reddish yellow-brown. The central longitudinal marking is well indicated by a black margin, and its posterior extremity is truncated. The normal angular bars or chevrons between this and the spinners are indicated by two converging rows of black spots or markings continued obliquely on the sides by more or less indistinct lines of black spots.

Sternum dark yellow-brown, with a not very distinct, short, longitudinal, central, yellowish line. The genital aperture is large and of a very distinct and characteristic form, of which a drawing alone can give any adequate idea. Examples of each sex were found near St. Gervais les Bains at an altitude of over 6000 feet.

I have thought it well to give a figure of some dissections and a description of this spider, as there is some confusion in respect to its identity with the *Lycosa riparia* C. L. Koch (Simon, 'Aranéides de France'). An example of this latter spider kindly sent to me by M. Simon for examination is undoubtedly of a quite distinct species from a typical example sent to me by Dr. Ludwig Koch, and bears a closer resemblance in some points to *L. prativaga* L. Koch. M. Simon tells me he received it many years ago from Dr. L. Koch, as *L. riparia* C. L. Koch. There was probably a mistake here somewhere, but Dr. Koch assures me that about the typical example he has sent to me now recently there is no doubt whatever as to its being the true *L. riparia* of C. L. Koch. The *L. riparia* C. L. Koch—Kulczynski—from Austria, is nearly allied to, if not identical with, the type Dr. L. Koch sent to me. On an examination, however, of Kulczynski's type specimen there appeared to me some differences in the form of the palpus and in the structure of the palpal organs; I do not therefore feel quite certain about it. The spiders formerly recorded (Ann. & Mag. N. H. ser. 4, xvi. pp. 257-258, 1875; and 'Spiders of Dorset,' pp. 380-381, 1881) as *L. riparia* and *L. prativaga* in England are certainly all of one species—*L. prativaga* L. Koch (*vide* Proc. Dorset Nat. Hist. and Antiq. Field-Club, vol. xvi. p. 119, 1895).

June 21, 1898.

W. T. BLANFORD, Esq., F.R.S., V.P., in the Chair.

Mr. J. Graham Kerr, F.Z.S., exhibited some specimens of *Lepidosiren* collected by him in the Gran Chaco of Paraguay during 1896-97. The adult males exhibited the characteristically varying appearances of the hind limb in the periods before, during, and after the breeding-season. Mr. Kerr also exhibited specimens of the young of *Lepidosiren*, illustrating especially the external gills and sucker, the disappearance of these organs, and the varying colour of the animal associated with the surrounding conditions of light or darkness.

A small collection of Teleostean Fishes, which had been obtained in the same region, and kindly identified by Mr. Boulenger, was also exhibited. Amongst its components the following species were interesting as characteristic inhabitants of the same range of swamps in which *Lepidosiren* was found:—

CICHLIDÆ.

Acara tetramerus Heck.

Crenicichla saxatilis L.

SILURIDÆ.

Callichthys asper Q. & G.

— *littoralis* Hancock.

Liposarcus pardalis Casteln.

CHARACINIDÆ.

Macrodon trahira Spix.

Erythrinus uniteniatus Spix.

Xiphorhamphus ferox Gthr.

Serrasalmo serrulatus C. & V.

SYMBRANCHIDÆ.

Symbranchus marmoratus Bl.

The Secretary called the attention of the Meeting to the arrival in the Society's Gardens of four fine living specimens of the Australian Lung-fish (*Ceratodus forsteri*), being the first examples of this fish which had been imported alive to Europe. They had been captured in the River Mary in Queensland and brought home from Brisbane in the S.S. 'Duke of Devonshire' by Mr. D. O'Connor¹, who had been engaged by the Royal Society of Queensland to transfer this fish into other Australian rivers besides those (the Mary and the Burnett) in which it was already known to exist. The specimens were kept in hot-water tanks (temperature 70° to 80°) in the Tortoise House and were fed principally upon prawns and shrimps.

¹ See his letter in the 'Field,' June 11th, 1898, vol. xci. p. 899.

Mr. D. O'Connor had supplied the following information on the *Ceratodus* :—

“Some ten or twelve years ago the late Sir Ferdinand von Mueller and other scientific men of Australia were apprehensive that *Ceratodus* was likely to become extinct, mainly owing to their being largely destroyed by settlers and miners, who highly esteemed them as an article of diet. They were mostly killed by dynamite, a very destructive agent. The curious fact was also noted that no small specimens of *Ceratodus* were ever seen; two of those in your gardens are the smallest I ever met with, excepting a stuffed specimen which measured 21 inches. The Royal Society of Queensland, with a view to the preservation of *Ceratodus*, resolved to remove specimens to new habitats. I was asked to undertake the work. My first month's experience was very discouraging, resulting in only one live fish, but better success followed and in less than six months sixty-nine fishes were transported to six new localities. This success encouraged me to try the experiment of taking a few to England. I had some caught and kept in captivity a few weeks and fed mainly on prawns. They were shipped in the ‘Duke of Devonshire’ on the 15th April, and arrived in London on the 12th June, after a passage of eight weeks. My success was mainly owing to the exceptionally fine weather enjoyed throughout the voyage, there not being an hour rough between the Brisbane River and the Thames.

“The native name of *Ceratodus* is ‘Teebine’; the settlers on the Burnett call it salmon on account of its red flesh: on the Mary River it is known as ‘Barramundi’; but this name is incorrectly given to several species of large freshwater fishes, it belongs rightly to *Osteoglossum leichardti*.”

Mr. Boulenger exhibited specimens of *Polypterus lapradii* Stdr., from the Lower Congo, provided with much developed external opercular gills as first described by Steindachner. One of these specimens measured 260 millim., thus exceeding by 30 millim. the largest hitherto recorded with persistent external gills. Mr. Boulenger had previously shown that the presence of these gills was not actually dependent on age, still less confined to the “larva” as stated by Bashford Dean, since out of three quite young *Polypterus palmas* Ayres, of the same size, one only was possessed of them. The fact that they persisted in what might be described as half-grown specimens rendered it probable that they were retained throughout life in certain individuals, as we know to be the case in some of our common Newts.

Mr. R. E. Holding made some remarks on some interesting animals he had observed during a recent visit to the Zoological Gardens at Belle Vue, Manchester.

Prof. Howes exhibited, on behalf of Mr. E. W. L. Holt, a
Proc. Zool. Soc.—1898, No. XXXIII.

specimen of a new British Fish (*Argentina silus*), obtained 80 miles south-west of the Scilly Islands.

Mr. Abbott H. Thayer, of New York, explained his method of demonstrating, by actual experiments, the underlying principle of protective coloration in animals, and invited the Members present and their friends to witness an exhibition of his demonstrations which he had arranged with the Secretary to take place in the Society's Gardens next day, at 11.30 A.M.

Mr. Boulenger read a Report on the Fishes recently obtained by Mr. J. E. S. Moore in Lake Tanganyika. He gave a list of 35 species, belonging to the families *Serranidæ*, *Cichlidæ*, *Mastacembelidæ*, *Siluridæ*, *Cyprinidæ*, *Characinidæ*, *Cyprinodontidæ*, and *Polypteridæ*. The general character of the fish-fauna, so far as had been ascertained, did not differ from that of the fresh waters of Africa, but most of the species were distinct, and the family *Cichlidæ* had furnished types of 10 new genera.

This paper will be published entire in the Society's 'Transactions.' Diagnoses of the new forms are subjoined.

SERRANIDÆ.

Lates microlepis, sp. n.—D. VII, II 11; A. III 8; Sq. 100–110 $\frac{12-13}{29-30}$. Distinguished from *L. niloticus* Hasselq., by smaller scales, a higher spinous dorsal, a longer caudal peduncle, and a truncate caudal fin.

CICHLIDÆ.

LAMPROLOGUS Schilth.—Six new species, which may be distinguished by means of the following synopsis:—

- I. Caudal rounded or truncate.
 A. Anal with 10 spines.
 D. XIX 8; Sq. 46 $\frac{5}{10}$; depth of body 4 times in total length *L. fasciatus*, sp. n.
 D. XX–XXI; Sq. 32–33 $\frac{5}{12}$; depth of body $2\frac{3}{4}$ to $2\frac{3}{4}$ times in total length *L. compressiceps*, sp. n.
 B. Anal with 7 or 8 spines; D. XIX–XX 8–9; Sq. 33–35 $\frac{5-7}{11-12}$; depth of body $2\frac{3}{4}$ times in total length *L. moorii*, sp. n.
 C. Anal with 5 spines.
 D. XX 8–9; Sq. 36–40 $\frac{5-6}{11-14}$; depth of body $3\frac{1}{2}$ to $3\frac{3}{4}$ times in total length *L. modestus*, sp. n.
 D. XVIII 10–11; Sq. 90–95 $\frac{10}{22-28}$; depth of body 4 times in total length *L. elongatus*, sp. n.
- II. Caudal deeply notched, crescentic; D. XX–XXI 7–8; A. VI–VII 6; Sq. 50–54 $\frac{6-7}{16-17}$ *L. furcifer*, sp. n.

TELMATOCHROMIS, g. n.—Body more or less elongate; scales ctenoid. Jaws with a series of conical teeth, followed by a broad band of minute tricuspid teeth; lateral teeth small, conical. Maxillary exposed. Dorsal with 20 to 22 spines, anal with 6 or 7.

T. vittatus, sp. n.—D. XXI–XXII 8; A. VII 5–6; Sq. 45–52 $\frac{6}{16}$; l. lat. $\frac{25-29}{13-15}$; depth of body $4\frac{1}{2}$ – $4\frac{2}{3}$ times in total length.

T. temporalis, sp. n.—D. XX–XXI 6–7; A. VI–VII 6–7; Sq. 43–46 $\frac{6}{12}$; l. lat. $\frac{25}{9-17}$; depth of body $3\frac{1}{4}$ to $3\frac{1}{2}$ times in total length.

JULIDOCROMIS, g. n.—Body elongate; scales ctenoid. Jaws very narrow, with a few curved canines in front, the outer of which are very large and tusk-like, followed on the sides and behind by minute conical teeth forming a narrow band. Maxillary exposed. Dorsal with 22 to 24 spines, anal with 8 or 9.

J. ornatus, sp. n.—D. XXII–XXIV 5; A. VIII–IX 4–6; Sq. 45–50 $\frac{6-7}{12-13}$; l. lat. $\frac{26-29}{10-15}$; depth of body 4– $4\frac{1}{2}$ times in total length.

PARATILAPIA Blkr.—5 new species:—

I. Dorsal with 16 spines; caudal feebly emarginate.

D. XVI 8; A. III 7; Sq. 33 $\frac{3}{9}$; l. lat. $\frac{21-22}{12-13}$; depth of body $2\frac{2}{3}$ times in total length; diameter of eye $3\frac{1}{2}$ times in length of head *P. pfefferi*, sp. n.

D. XVI 10–12; A. III 6–7; Sq. 33–34 $\frac{3}{10}$; l. lat. $\frac{33}{15-17}$; depth of body 3 times in total length; diameter of eye $2\frac{2}{3}$ times in length of head *P. macrops*, sp. n.

II. Dorsal with 12 or 13 spines and 13 to 15 soft rays.

A. Caudal deeply emarginate, crescentic; A. III 9–10; depth of body $2\frac{2}{3}$ –3 times in total length.

Sq. 34–36 $\frac{4}{13-14}$; l. lat. $\frac{30-36}{10-16}$ *P. ventralis*, sp. n.

Sq. 60–63 $\frac{4-5}{16-17}$; l. lat. $\frac{54-55}{28-32}$ *P. furcifer*, sp. n.

B. Caudal feebly emarginate; A. III 10–12;

Sq. 39–40 $\frac{2-3}{11}$; l. lat. $\frac{27-31}{11-13}$; depth of body

4– $4\frac{1}{3}$ times in total length *P. leptosoma*, sp. n.

BATHYBATES, g. n.—Body elongate, scales cycloid, small and irregular. Several rows of large fang-like teeth in the jaws. Maxillary exposed. Dorsal with 14 spines, anal with 3.

B. ferox, sp. n.—D. XIV 15; A. III 16; Sq. 68 $\frac{7}{38}$; l. lat. $\frac{68}{44}$; depth of body 4 times in total length.

ERETMODUS, g. n.—Body moderately elongate; scales ctenoid. Jaws with rather large spatulate teeth with truncate crowns disposed in oblique transverse rows of two or three. Lips much developed; maxillary entirely concealed when the mouth is closed. Dorsal

with 23 to 25 spines; soft rays reduced to 3 to 5; anal with 3 spines.

E. cyanostictus, sp. n.—Sq. 32-35 $\frac{3}{11-12}$; l. lat. $\frac{22-23}{6-9}$; depth of body 3 times in total length.

TILAPIA A. Smith.—A single species, remarkable for its very strongly developed lips, both produced into a large triangular lobe in front:—

T. labiata, sp. n.—D. XVIII 10; A. III 6-7; Sq. 33-35 $\frac{5-6}{12-13}$; l. lat. $\frac{22-25}{13-15}$; depth of body $2\frac{2}{3}$ - $2\frac{3}{4}$ times in total length.

TROPHEUS, g. n.—Body moderately elongate; scales ctenoid. Jaws angularly bent at the sides, with bands of minute tricuspid teeth, an outer row of bicuspid teeth, and enlarged conical teeth at the sides of the premaxillary; mouth transversely linear when closed; maxillary concealed under the preorbital. Dorsal with 21 spines, anal with six.

T. moorii, sp. n.—D. XXI 5-6; A. VI 5-6; Sq. 30-32 $\frac{3}{12}$; l. lat. $\frac{22-25}{11-12}$; depth of body $2\frac{1}{2}$ to $2\frac{2}{3}$ times in total length.

SIMOCHROMIS, g. n. for *Chromis diagramma* Gthr., differing from *Tilapia* in the sides of the premaxillary being armed with a single series of conical teeth.

PETROCHROMIS, g. n.—Body moderately elongate; scales ctenoid. Jaws with very broad bands of minute bristle-like teeth, with bi- or tricuspid crowns; maxillary concealed under the preorbital. Dorsal with 17 or 18 spines, anal with 3.

P. polyodon, sp. n.—D. XVII-XVIII 8-9; A. III 7-8; Sq. 32-34 $\frac{3-4}{12-13}$; l. lat. $\frac{22-24}{13-17}$; depth of body $2\frac{1}{2}$ to $2\frac{2}{3}$ times in total length.

PERISSODUS, g. n.—Body elongate; scales cycloid. Teeth rather large, unequal in size, few, with swollen bases and low, compressed, and slightly notched crowns perpendicular to the axis of the jaws, disposed in a single series; maxillary exposed. Dorsal with 18 spines, anal with 3.

P. microlepis, sp. n.—D. XVIII 10; A. III 8; Sq. 65 $\frac{5}{20}$; l. lat. $\frac{44}{30-31}$; depth of body $3\frac{2}{3}$ times in total length.

MASTACEMBELIDÆ.

Mastacembelus moorii, sp. n.—D. XXV-XXVII 70-80; A. II 70-80. Vent equally distant from end of snout and base of caudal fin; length of head twice in its distance from the vent, and nearly $\frac{1}{3}$ in its distance from the first dorsal spine; no preopercular spine.

SILURIDÆ.

Clarias liocephalus, sp. n.—D. 70; A. 50. Caudal free. Head smooth, slightly longer than broad, 5 times in total length;

maxillary barbel as long as head. Vomerine teeth in a narrow band, without posterior process.

Synodontis multipunctatus, sp. n.—Mandibular teeth in a single series of 16, nearly straight, simple, measuring hardly $\frac{1}{3}$ diameter of eye; depth of body $3\frac{1}{4}$ in total length; snout rounded, twice as long as eye; maxillary barbel reaching a little beyond anterior third of pectoral spine; dorsal spine serrated behind; adipose fin a little shorter than the head, twice as long as its distance from the dorsal; humeral process sharply pointed.

CYPRINODONTIDÆ.

Haplochilus tanganicanus, sp. n.—Body compressed, its depth 4 times in total length: D. 13; A. 26; Sq. 42; l. tr. 11.

Diagnoses of two new genera of *Cichlidae* were also added, based on specimens forming part of a collection made in Tanganyika by Capt. Descamps, of the Congo Free State:—

Ectodus, g. n.—Teeth very small, conical, in two series in both jaws, the outer larger; outer mandibular teeth pointing outwards, perpendicular to the others; maxillary concealed under the præ-orbital when the mouth is closed. Scales rather large, ctenoid.

E. descampsi, sp. n.—D. XIV 14; A. III 8; Sq. $34\frac{3}{10}$; l. lat. $\frac{28}{15}$. Eye very large, $2\frac{1}{2}$ times in length of head.

E. melanogenys, sp. n.—D. XIV 16; A. III 13. Eye 4 times in length of head.

Plecodus, g. n.—Teeth large and few, in a single series, dilated at the base, truncated at the end, compressed, slightly grooved in front, curved and directed backwards; 14 teeth in upper jaw, 12 in lower; maxillary exposed. Scales moderate, cycloid.

P. paradoxus, sp. n.—D. XIX 14; A. III 12; Sq. $65\frac{6}{17}$; lat. l. $\frac{50}{40}$.

The following papers were read:—

1. On the Scorpions, Spiders, and Solpugas collected by Mr. C. Steuart Betton in British East Africa. By R. I. Pocock, of the British Museum of Natural History.

[Received May 28, 1898.]

(Plates XLI. & XLII.)

On his return to England in the summer of 1897, Mr. Betton, a member of the staff of engineers employed in the construction of the railroad now in process of being laid between Mombasa and Lake Victoria, brought home a valuable series of zoological specimens and generously presented them to the Trustees of the British Museum.

The Arachnida, which came into my hands for determination and form the subject-matter of the present communication, proved upon examination to be of very considerable interest; for not only was there a large percentage of new forms amongst them, but the series contained as well examples of several species, which, though already described by continental authors, were not at the time represented in the National Collection.

Of the Scorpions none were new to science; but of the species known as *Pseudobuthus dentatus* there were no specimens in the Museum at the time; and of the little flat black species named *Iomachus politus*, of which a large series of adults and young of both sexes were obtained, we only possessed a solitary example (the *type*), sent some years previously from Mombasa by Mr. Wilson. The rest of the Scorpions, though not in any way novelties, form valuable additions to our series.

So far as "*species novæ*" are concerned, the Solpugas (Solifugæ) contrast very forcibly with the Scorpions, since out of the six species sent home, one only appears to have been already named. The rest are representatives of well-known African genera.

Of the Spiders nearly all the Theraphosidæ appear to be representatives of new species, the most interesting being the specimen of the new genus *Eucratoscelus* and the series of examples including the previously unknown male of *Pisenor höhneli*. Most of the Argiopidæ are well-known forms of wide distribution in tropical Africa; but specimens of the protectively coloured and fantastically shaped genera *Poltys* and *Cærostris* seem to be referable to species which have hitherto escaped the vigilance of collectors in that part of the world. The capture of a male of the species of *Cærostris* is a feat upon which Mr. Betton is to be especially congratulated.

Order SCORPIONES (SCORPIONS).

Family SCORPIONIDÆ.

Genus SCORPIO Linn.

? SCORPIO BELLICOSUS L. Koch.

? *Scorpio bellicosus*, L. Koch, Aegyptische und Abyssinische Arachniden, p. 1, pl. i. fig. 1 (1875).

Loc. Ndi (Weiss Road Camp).

A single female example collected by Mr. Betton resembles the females obtained in Somaliland by Dr. Donaldson Smith, which I have identified as *Scorpio bellicosus* of L. Koch. The accuracy of the determination, however, must remain a matter of doubt until the male is procured or until the genuine female of *bellicosus* comes to hand for comparison.

SCORPIO GREGORII Pocock.

Scorpio gregorii, Pocock, Ann. Mag. Nat. Hist. (6) xvii. p. 432, pl. xviii. fig. 2.

Loc. Ndi (Weiss Road Camp).

This species will in all probability prove to be identical with the form previously described by Dr. Kraepelin as *Sc. pallidus*, from Sumatra. The locality "Sumatra" is almost certainly erroneous.

Dr. Gregory obtained the species at Tzavo, Kinani, &c.

Genus IOMACHUS Poc.

IOMACHUS POLITUS Pocock.

Iomachus politus, Pocock, Ann. Mag. Nat. Hist. (6) xvii. p. 317 (1896); Kraepelin, Jahrb. Hamb. Wissen. Anstalten, xiii. p. 138, figs. 19-22.

Loc. Maziwa Mitatu, Machuma, Mbuyuni, Voi, and Samburu.

Though this little flat Scorpion is evidently abundant near Uganda, the species was hitherto represented in the British Museum by a single young specimen, the type, obtained by Mr. Wilson at Mombasa. Prof. Kraepelin has recorded the species from Dar es Salam and Bagamoyo.

Family BUTHIDÆ.

Genus BUTHUS Leach.

BUTHUS EMINII Pocock.

Buthus eminii, Pocock, Ann. Mag. Nat. Hist., July 1890, p. 98, pl. i. fig. 2.

Loc. Voi.

Also obtained by Dr. Gregory at Ndara and Athi and by Emin Pasha on the shores of Lake Victoria Nyanza.

Genus PARABUTHUS Poc.

PARABUTHUS PALLIDUS Pocock.

Parabuthus pallidus, Pocock, Journ. Linn. Soc., Zool. xxv. p. 312.

Loc. Machuma in the Taru desert.

Previously recorded from Mombasa (*D. J. Wilson*), and Giriama near Fuladoya (*J. W. Gregory*).

Genus PSEUDOBUTHUS Poc.

PSEUDOBUTHUS DENTATUS (Karsch).

Odonturus dentatus, Karsch, Sitzb. nat. Fr. Berlin, 1879, p. 119.

Rhoptrurus dentatus, id. Berl. ent. Zeit. xxx. p. 77 (1886).

Pseudobuthus dentatus, Kraepelin, Jahrb. Hamb. Anst. xiii. p. 121 (1896).

Males, females, and young of this species, which is new to the British Museum collection, were taken at Samburu, Machuma, Mbuyuni, and Voi. The adults, measuring about 70 mm. in length, are mostly of an earthy-red colour with an indistinct median dorsal line; but a young example (40 mm.), which has the aspect of a distinct species, is yellow, with the dorsal surface trilineate; the humerus, brachium, and manus of the chelæ, as well as the femora

and patellæ of the legs, are blotched with black, and the lower surface of the tail has a median dark line and a pair of fuscous patches on each side of it.

This species, the type and only known representative of the genus *Pseudobuthus*, may be compared with the type and only known species of the genus *Tityobuthus* as follows:—

a. Vesicle of tail smooth and punctured below, tooth below aculeus small; 5th and 4th segments of tail at most weakly granular below, not crested; last abdominal sternite not crested; 2nd caudal segment with median lateral crest almost complete; brachium of chela and homologous segment of legs (patella) not crested; densely variegated.

Tityobuthus haroni (Poc.). Madagascar.

b. Vesicle of tail granular below, tooth long; 4th and 5th segments of tail and last abdominal segment distinctly crested below, brachium of chela and patella of legs also crested; 2nd caudal segment without median lateral crest; prevailing colour yellow or red, weakly infuscate.

Pseudobuthus dentatus (Karsch).

Genus ARCHISOMETRUS Kraepelin.

ARCHISOMETRUS BURDOI (Simon).

Isometrus burdoi, Simon, Bull. Soc. Ent. Belg. 1882, p. lviii; Pocock, Journ. Linn. Soc., Zool. xxiii. p. 443, pl. xi. fig. 5 (1890).

Loc. Voi.

Previously known from Lake Nyassa, Kilimanjaro, &c.

Order ARANEÆ (SPIDERS).

Family THERAPHOSIDÆ.

Subfamily HARPACTIRINÆ.

Harpactirinæ, Pocock, Proc. Zool. Soc. 1897, p. 748.

Genus EUCRATOSCELUS, nov.

Allied to *Pterinochilus*, but differing in having the legs of the 4th pair much longer than those of the 1st, the patella and tibia of the 4th being also much longer than those of the 1st; the tibia being very stout and hairy, its width exceeding a third of its length and being at least as wide as the distal end of the femur. In *Pterinochilus*, on the contrary, the 4th leg is only a little longer than the 1st, with patella and tibia not longer (? always shorter) than those of the 1st, the tibia itself being normally hairy, slender, cylindrical, and narrower than the femur.

Type, *E. longiceps*.

EUCRATOSCELUS LONGICEPS, sp. n.

Colour. Carapace and limbs covered with a clothing of short greyish-brown hairs, the setæ reddish brown, the lines on the legs paler; distinct whitish tufts or bands at the extremities of the femora, patellæ, tibiæ, and protarsi; abdomen a deep chocolate-brown, with reddish bristles; sternum and coxæ blackish, with greyish hairs.

Carapace moderately high in the head-region, its width less than three-quarters its length (13:18½); length exceeding that of patella and tibia of the 1st leg by one-third of the protarsus, a little less than those of 4th leg, equal to patella, tibia, and tarsus of palp, less than tibia, protarsus, and tarsus of 2nd leg by at least half the tarsus; length from fovea to anterior border equal to 4th protarsus; width a little less than patella and tibia of 2nd leg and a little greater than those of 3rd leg. Eyes as in *Harpactira*; tubercle high, nearly spherical; distance between the anterior lateral eye and the edge of the clypeus exceeding the long diameter of the eye.

Mandibles with nine large teeth and smaller granuliform teeth.

Labium with about three rows of spicules.

Palpi, when extended, just surpassing the tip of the tibia of the 1st leg; unarmed, except for one spine below at the apex of the tibia.

Legs (from the base of the femur) 4, 1, 2, 3; the 3rd falling short of the 2nd by two-thirds of its tarsus, the 2nd falling short of the 1st by about half its tarsus, the 1st less than the 4th by its tarsus and about one-fourth of its protarsus, the 4th exceeding the 3rd by its tarsus and three-fourths of the protarsus; a pair of apical spines on the lower surface of the tibia and a median spine at the apex of the protarsus of the 3rd and 4th; patella and tibia of 4th exceeding those of the 1st by almost half the protarsus, about equal to the tibia, protarsus, and tarsus of the 3rd leg, which are very slightly longer than the protarsus and tarsus of the 4th; tibia and protarsus of 1st a little shorter than protarsus and tarsus of 4th; tibia of 1st a little longer than the protarsus, a little more than twice as long as broad; tibia of 4th a little shorter than the protarsus, its width rather more than one-third of its length; width of 4th protarsus about one-fourth of its length.

Measurements in millimetres.—Total length of body 42, of carapace 18·5, width of latter 13, length from fovea 12; length of palp 27·5, of 1st leg 43, of 2nd 40, of 3rd 36, of 4th 52·5; patella and tibia of 1st 15·5, of 4th 18·8; width of tibia of 1st 3, of 4th 4.

Loc. Voi. A single female example of this interesting new Spider was obtained.

Genus PTERINCHILUS Pocock.

PTERINCHILUS MURINUS Poc.

Pterinophilus murinus, Pocock, Proc. Zool. Soc. 1897, p. 753, pl. xliii. fig. 4.

The type of this species was a rather mutilated female example from Ugogo (Emin Pasha). Female specimens were also recorded from Mombasa and the north-east shore of Victoria Nyanza. These examples prove to be not quite full-sized. I am therefore glad of the opportunity to point out further specific features observed in the well-preserved material obtained by Mr. Betton at Ndi, Mbuyuni, and Machuma.

The largest female measures 39 mm. long, the carapace being 19 long and 18·5 broad.

The carapace is covered with golden hairs, showing a more or less radial arrangement in stripes; the abdomen is yellowish or greyish brown, symmetrically spotted and striped above.

The carapace is a little longer than the patella and tibia of the 4th and 1st legs (in smaller examples, as in the type, it is about equal), and about equal to tibia and protarsus of 1st (in young examples a little greater). The spine armature of the legs is as in the type.

Measurements in millimetres of largest example.—Total length 39; length of carapace 18·5, width 15·5; length of 1st leg 49, 2nd 45, 3rd 41, 4th 51, palpus 31.

In addition to the examples mentioned above that were obtained on the Uganda-Mombasa Railway, the British Museum has recently received an adult female from Portuguese E. Africa. The species evidently, therefore, has a wide distribution in eastern equatorial Africa.

PTERINOCILUS SPINIFER, sp. n. (Plate XLI. figs. 1, 1 a.)

♂. *Colour.* Carapace and mandibles black, but somewhat thickly covered with golden-yellow hairs; legs also blackish, but covered with golden hairs, intermixed with grey and blackish; the extremities of the femora, patellæ, tibiæ, and protarsi whitish; abdomen golden yellow at the sides, passing into black on the dorsal middle line, the black especially conspicuous posteriorly; lower surface of abdomen greyish yellow; sternum and coxæ blackish with yellowish long hairs.

Carapace convex, its width more than two-thirds of its length; length much less than that of tibia and patella of 4th leg, scarcely equal to protarsus of 4th, a little less than patella and tibia of 2nd, greater than those of 3rd, less than protarsus and tarsus of 3rd, about equal to patella, tibia, and tarsus of palp; its width a little less than tibia of 4th, equal to protarsus of 1st, slightly greater than tibia of 1st, much less than patella and tibia of 3rd. Ocular tubercle nearly spherical; clypeus narrow, less than one-fourth the length of the tubercle; space between the edge of the clypeus and the anterior lateral eye about equal to its long diameter.

Legs 4, 1, 2, 3, the 4th exceeding the 1st by two-thirds the length of the tarsus, patella, and tibia of 4th, a little greater than those of 1st, equal to protarsus and tarsus of 1st; tibia of 1st very thick, the thickest segment in the limb, its width at least equal to one-third of its length, the spine long and strong; protarsus bowed as in *P. vorax*, but armed below at its distal end with a strong tuberculiform spike; tibia armed below distally with a pair of apical spines; protarsi of 3rd and 4th with a few apical spines and with one median external spine, of 4th with one superior distal spine.

Measurements in millimetres.—Total length 20; length of carapace 9·5, width 7·5; length of 1st leg 34·5, of 2nd 31, of 3rd 27,

of 4th 37.5; patella and tibia of 1st 11.5, of 4th 12; protarsus of 4th 10.

Loc. Mbuyuni. A single male example.

Much smaller than *P. vorax* Poc. (P. Z. S. 1897, p. 752), with relatively much longer legs &c. For example in *vorax* the carapace is just about as long as the patella and tibia of the 4th legs, and its width is greater than the protarsus of the 4th; there is, moreover, no spine upon the protarsus of the 1st, and the tibia is not thick as in *spinifer*.

The males of the three known species of *Pterinochilus* may be distinguished as follows:—

- a. Protarsus of 1st leg with a distinct tuberculiform tooth below near the apex, tibia of 1st leg thicker than the femur; legs longer; carapace less than patella and tibia of 2nd leg and less than 4th protarsus, &c. *spinifer*, sp. n.
- b. Protarsus of 1st leg without tuberculiform tooth, tibia of 1st not thicker than its femur; legs shorter; carapace exceeding patella and tibia of 2nd leg, and much longer than protarsus of 4th.
 - a'. Of large size (carapace about 16 mm.); protarsus of 1st leg basally sinuate; carapace much longer than patella, tibia, and tarsus of palp; spine of palpal organ simple and attenuate *vorax* Poc.
 - b'. Of small size (carapace 10 mm.); protarsus of 1st leg straight; carapace not longer than patella, tibia, and tarsus of palp; spine of palpal organ with a strong upstanding crest and a blunt point..... *nigrofulvus* Poc.¹

Subfamily EUMENOPHORINÆ.

Eumenophorince, Pocock, Proc. Zool. Soc. 1897, p. 773.

Genus PHONEYUSA Karsch.

PHONEYUSA BETTONI sp. n.

Closely allied to *P. gregorii*, Pocock (P. Z. S. 1897, p. 761).

Hairy coating a bright reddish brown, with conspicuous pale narrow tufts at the tips of femur, patella, tibia, and protarsus of legs; the lines on the legs reddish.

Width of *carapace* more than three-fourths of its length; its length only a little greater than that of patella and tibia of palp, equal to length of patella and tibia of 2nd leg, a little less than protarsus and tarsus of 1st or 2nd, these two being about equal; very slightly exceeding 4th protarsus; its width slightly exceeding tibia and tarsus of palp and a little less than patella and tibia of 3rd leg; distance between fovea and anterior edge scarcely equal to 3rd protarsus, and slightly exceeding protarsus of 1st and 2nd.

Palp when extended reaching nearly to the apex of tibia of 1st leg, unspined, its tibia about four times as long as broad, a trifle longer than that of the 2nd leg, nearly twice as long as patella of palp and three times as long as its tarsus; the bulb of the same form as in *gregorii*.

¹ Poc. Ann. & Mag. Nat. Hist. (7) i. p. 317. From the Transvaal.

Legs 4, 1, 2, 3 (from base of femur), 4th surpassing 1st almost by length of its tarsus; 1st surpassing 2nd by half its tarsus, 2nd surpassing 3rd by less than half its tarsus, 4th surpassing 3rd by its tarsus and one-third of its protarsus; patella and tibia of 1st and 4th about equal; protarsus of 4th almost equal to patella and tibia of 2nd; tibia of 4th without inferior distal spines, of 3rd with one anterior distal spine below; tibia of 2nd and 1st with a pair of inferior distal spines; protarsus of 1st with two, of 2nd with three, of 3rd and 4th with four inferior apical spines.

Measurements in millimetres.—Total length of trunk 38, of carapace 18.5, from fovea to anterior border 12.5; width of carapace 16; length of palpus 34.5, of 1st leg 60, of 2nd 56, of 3rd 52, of 4th 68.5, of patella and tibia of 1st and 4th 22, of 4th protarsus 18.

Loc. Voi. A single male example.

This species and *P. gregorii* may be distinguished as follows:—

- a. Palp shorter; the carapace equal in length to its patella, tibia, and tarsus, its tibia not so long as that of the 2nd leg, its width more than one-fourth of its length; tibiæ of 3rd and 4th legs with a pair of apical spines below *gregorii* Poc.
- b. Palp longer; carapace only equalling its patella and tibia, its tibia slightly longer than that of the 2nd leg and four times as long as broad; tibia of 4th leg without inferior spines, that of the 3rd with one inferior distal spine *bettoni*, sp. n.

In connection with this species it is interesting to observe the absence of inferior spines upon the tibia of the 4th leg, since this feature was mentioned by Karsch in his diagnosis of *Pelinobius* as serving to distinguish that genus from the previously established *Phoneyusa*. But, in spite of a strong suspicion I venture to entertain that *Pelinobius* will prove to be synonymous with *Phoneyusa*, I refrain from definitely uniting the genera, since M. Simon declares the arrangement of the eyes to be different in the two. The type of *Pelinobius*, namely *muticus*, was from Masailand (see JB. Hamburg. Wissen. Anst. ii. p. 135, 1885); but although agreeing in the main with both *gregorii* and *bettoni*, it is certainly the representative of a totally distinct species, if any reliance is to be placed upon the figure and description. The legs, for example, are said to be without spines, and they are evidently shorter as compared with the size of the carapace; for example, the width of this plate is equal to the length of the 4th protarsus.

Family BARYCHELIDÆ.

Genus PISENORODES, nov.

Allied to *Pisenor* Simon, but differing apparently in the structure of the tarsus of the palp in the male. The tarsus is long and slender, three times as long as wide, nearly as long as the tibia of the palp, scopulate, but not bilobed at the apex, the papal bulb arising from the base of its lower side.

This new genus is proposed for the reception of the species,

represented by male and female examples, obtained by Mr. Betton and believed to be identical with the form named *P. höhneli* by Simon.

The type of *Pisenor* is a species from the Zambesi, named *notius* by Simon (Act. Soc. Linn. Bord. xlii. p. 411, 1889). The male of it is as yet unknown, and it may consequently prove to have the same sexual features as the genus here established. In that case *Pisenorodes* will lapse as a synonym of *Pisenor*. But Simon has described the male of a second species, which he refers to *Pisenor*, namely *P. nigellus* (*loc. cit.* p. 411), from Landana, Congo; and the tarsus of this species is described as small, narrow, and bilobate, being apparently constructed much as in the allied genus *Idiomata*, and in the genera of Theraphosidæ. In that case *P. nigellus* can hardly be congeneric with the species here identified as *höhneli*; and since it has been definitely referred to *Pisenor*, it appears to me advisable to establish a new genus for the species now before me. If this species be wrongly determined it must have a new specific name and can still be regarded as type of this new genus.

PISENORODES HÖHNELI (Simon). (Plate XLI. figs. 2-2 b.)

Pisenor höhneli, Simon, Ann. Soc. Ent. France, 1889, p. 125.

Recorded from Kilimanjaro by Simon. Mr. Betton obtained specimens at the following localities:—Samburu and at Taru, Maziwa ya Tagari and Machuma in the Taru desert.

The female examples I am unable to separate from the female of *höhneli* as described by Simon. But since the male is new to science, the following particulars regarding it may be mentioned:—

The *carapace* is as long as the patella and tibia of the 4th leg and the tarsus and protarsus of the 1st, slightly shorter than patella and tibia of the 2nd, and distinctly shorter than protarsus of 4th, about equal to patella, tibia, and tarsus of the palp; its width is almost as great as its length.

Legs 4, 1, 2, 3; protarsus of 4th longer than protarsus and tarsus of 1st; tibia of 1st armed distally with an inferior process tipped with a single strong spine, above and behind this is a second very stout, slightly curved spine, and in addition to these the segment is armed with about eleven long slender spines; the protarsus is slender and lightly bowed and armed with 1 (2) external basal spines. *Palp* projecting halfway along the tibia of the 1st leg when extended, its femur spined at the apex on the inside; its patella with two short basal spines on the inner side; tibia with about five spines on the inner side, thickly hairy below, with a naked median channel for the reception of the palpal spine, while the distal end is hollowed beneath for the reception of the bulb; *palpal bulb* subglobular, the spine longish, straight, with a bent tip, broad, more or less spatulate, slightly constricted at the base, with a slight spiral twist. Femora, patella, and tibia of all the legs spiny.

Mandible armed with a single internal row of nine large teeth and a few small granules posteriorly. *Maxilla* lightly depressed at the

base, with a few cusps; *labium* with a row of four cusps. *Sternal sigilla* marginal.

Measurements in millimetres.—Total length of trunk 22, carapace 10·5; width of carapace 9·5; length of palpus 16·5, of 1st leg 32, 2nd leg 30·5, 3rd leg 28, 4th leg 37, patella and tibia of 1st 12, of 4th 10·5.

The species described from Moschi as *Idionmata lepida* by Gerstäcker (Von der Decken's Reisen in Ost-Afrika, iii. 2, p. 485) was based upon a male example which, as suggested by Simon, perhaps belongs to the genus *Pisenor*; in any case it is certainly different from the male here identified as *Pisenorodes höhneli*. In the first place, it is very much smaller, the body and mandibles measuring only 12·5 mm. in length, and there is not a word in the description to credit the belief that the tarsus of the palp and the tibia of the 1st leg are constructed as in the species I have here described.

Family CTENIZIDÆ.

Genus CYRTAUCHENIUS Thorell.

CYRTAUCHENIUS FLAVICEPS, sp. n.

Carapace with its head-region clear reddish yellow, with a fine median fuscous line studded with a series of setiferous pores; the head bordered by a broad brown band on each side, which passes back to the fovea; sides of the thoracic portion paler than the median portion; mandibles, palpi, and anterior two pairs of legs dark brown; 4th leg a little paler; abdomen a uniform greyish brown; sternum and coxæ yellowish.

Carapace as long as patella and tibia of 4th leg, and as patella, tibia, and half the protarsus of the 1st, its width equal to protarsus and tarsus of 4th leg; length from fovea to anterior border equal to tibia of 4th. *Ocular area* more than twice as broad as long; the eyes of the posterior line wider than those of anterior, of which the lateral are close to the edge of the clypeus. Eyes of anterior line procurved; a line touching the anterior border of the medians would pass behind the centres of the laterals; space between anterior medians equal to about half their diameter; laterals larger than medians and larger than posterior laterals, which are quite close to the posterior medians.

Rastellum consisting of strong spines overhanging the base of the fang; internally some of these fangs are longer and arranged more thickly, externally they are shorter and form a single series; lower margin of mandible with an inner series of about nine teeth, the external row consisting of a series of granules; fang longish. *Labium* and *maxillæ* unarmed, bristly.

Legs longish and slender, except those of the 3rd pair, which are shorter and have the femur and patella thick: 1st leg with a single median apical spine on the tibia, and two spiniform setæ behind it, and 7 inferior spines on the protarsus amongst the scopular hairs, arranged approximately 2, 2, 3, the latter being at the apex; 2nd

leg spined like the 1st, with one or two shorter protarsal spines; 3rd leg with patella rather thickly spiny in front, bristly above, with 1 posterior apical spine, tibia with 2 spines in front, 2 behind, 4 above; protarsus with 2, 2, 3 spines below and about 14 spines above—5 forming an anterior, 8 a posterior series, and 1 median dorsal; tarsus with 1, 1 spines above; 4th leg with tibia bearing 1 posterior spine and a few setiform spines below, its protarsus armed with numerous spines in front below, those at the apex being long and strong, and two spines behind, one median, one apical; tarsus with many short spines on the anterior side of the lower surface. *Claws* with two rows of strong teeth, those of the 3rd and 4th legs less strongly toothed than those of the 1st and 2nd. *Mamillæ* longish, the apical segment acuminate, but little shorter than the second.

Measurements in millimetres.—Total length of trunk 18; length of carapace 8; width 5·5; length from fovea 5; length of palp 11, of 1st leg 17, of second 14·5, of 3rd 11, of 4th 18·5, patella and tibia of 1st 7, of 4th 8.

Loc. Voi. A single female example.

The generic position of this species must at present be left unsettled. In a general sense it falls under *Cyrtouchenius* as defined by Simon. In the structure of the mamillæ it seems to resemble *C. zebra* of Simon, from Zululand (Ann. Soc. Ent. France, lxi. p. 272, 1893), but in other characters, such as size of eyes, spine-armature of anterior tibia and of 3rd tarsus, it approaches *C. terricola*.

Genus ACANTHODON Guérin.

ACANTHODON ROBUSTUS, sp. n.

Colour of carapace brownish yellow; legs darker, with fuscous longitudinal stripes; inner surface of femora of palpi and first two pairs of legs pale yellow.

Length of carapace exceeding that of tibia and protarsus of 4th leg (in *lacustris* it is greater). Ocular arrangement almost as in *lacustris*¹, but the ocular area shorter, the width across the tubercle exceeding the length from the posterior border of the tubercle to the anterior tubercle of the anterior lateral eyes (in *lacustris* the length of the area slightly exceeds the width of the tubercle); width of ocular area at least half the length of the 4th protarsus.

Labium with a transverse row of 4 or 5 spicules.

Legs and palpi spined as in *lacustris*, but the spines are more numerous; moreover the posterior side of the tibia of the 2nd leg is armed with strong short spines, and on the anterior side of the patella, tibia, and protarsus of the 3rd leg the spines are arranged closely together, forming distinct band-like areas; whereas in

¹ By an error in the description (P. Z. S. 1897, p. 731) the anterior median eyes are described in *lacustris* as being separated by a space exceeding twice their diameter; the distance is about equal to a diameter; and the distance between these eyes and the posterior laterals is equal to about twice the diameter of the former.

lacustris the spines are relatively few in number and more scattered. Coxæ thickly hairy below, coxa of 3rd with a band of close-set short spikes. Legs 4, 1, 3, 2; tibia of 3rd thick, its width slightly exceeding its superior length; width of femur of this leg about two-thirds its superior length (in *lacustris* barely more than half).

Measurements in millimetres.—Total length of trunk 33, of carapace 14 (with mandibles 19); length of palpus 21, of 1st leg 24, 2nd 22, 3rd 23, 4th 31 (all from base of femur); patella and tibia of 1st 10, of 4th 12; tarsus and protarsus of 4th 10.

Loc. Taru and Machuma in the Taru desert (*type*). A female example from each of these localities.

This species and *Acanthodon lacustris*, recently described from Kinyamholo, Lake Tanganyika (P. Z. S. 1897, p. 731), may be distinguished by the following characters:—

- | | | |
|----|--|--------------------------|
| a. | Labial teeth 4-5; external side of tibia of 2nd leg armed with short robust spines; coxæ of legs densely hairy below, that of 3rd leg with an oblong area of close-set spinules; legs shorter, protarsus of 4th rather less in length than twice the width of the ocular area; width of ocular area exceeding by a little the length of the upperside of the 3rd tibia; width of 3rd tibia equal to its length | <i>robustus</i> , sp. n. |
| b. | Labial teeth 2; external surface of 2nd tibia without short stout spines; coxæ of all the legs almost sparsely hairy below; legs longer, protarsus of 4th exceeding twice the width of the ocular area, which is slightly less than the length of the 3rd tibia; width of 3rd tibia exceeding its length | <i>lacustris</i> Poc. |

It appears to me impossible to say whether the species described by Gerstäcker as *Idiops compactus* belongs to the genus *Acanthodon* or to the allied genus *Heligmomerus*. It was procured at Dafeta, Kilimanjaro, a locality which at first suggests the possibility of identity between it and *Acanthodon robustus*. But according to Gerstäcker, *compactus* has only a pair of labial teeth as in *lacustris*, and is much smaller than *robustus*, the total length of carapace and mandibles being 13.5 mm. Moreover the legs of the 3rd pair are said to be shorter than the rest, and the palpi as long as the legs of the 1st pair—characters which do not apply to *robustus*.

FAMILY ARGIOPIDÆ.

GENUS NEPHILA Leach.

NEPHILA MADAGASCARIENSIS (Vinson).

Epeira madagascariensis, Vinson, *Aranéides des Iles Réunion, Maurice et Madagascar*, p. 191, pl. vii. (= *N. argyrotoxa* Gerst.).

Loc. Maziwa Mitatu in the Taru desert.

Widely distributed throughout East Africa.

NEPHILA SUMPTUOSA Gerstäcker.

Nephila sumptuosa, Gerstäcker, *Von der Decken's Reisen in Ost-Afrika*, iii. 2, p. 501, pl. xviii. fig. 12.

Loc. Mgana, Maziwa Mitatu, Marago-ya-Fundi.

This species has a wide range throughout East Africa and is also abundant in Socotra. Fortunately the admirable figure of it published by Gerstäcker makes the identification of the species a matter about which there can be little doubt.

NEPHILA PILIPES (Lucas).

Epeira pilipes, Lucas, Thomson's Arch. Ent. ii. p. 416, pl. xiii. fig. 7 (1858).

Loc. Taru.

Abundant throughout tropical Africa and extending as far south as Cape Colony.

Genus ARANEUS Linn.

(= *Epeira* of authors.)

ARANEUS NAUTICUS (L. Koch).

Epeira nautica, L. Koch, Aegyptische und Abyssinische Arachniden, p. 17, pl. ii. fig. 2 (1875).

Loc. Taru.

Almost cosmopolitan in range.

? ARANEUS SIMILIS (Bösenberg and Lenz).

Epeira similis, Bösenberg and Lenz, Jahrb. Hamb. Wissen. Anst. xii. p. 20, pl. ii. figs. 26-26 b.

? *Epeira suedicola*, Simon, Ann. Soc. Ent. Fr. (6) x. p. 103 (1890).

An adult male and a mutilated female from Changamwe and an immature female from Taru are doubtfully referred to this species, recorded by its describers from Quilimane. Judging by the form of the vulva, *A. similis* and *A. striata* of Bösenberg and Lenz are closely allied to *A. suedicola*, which Simon recorded from Arabia and which Pavesi has since recorded from Somaliland (Ann. Mus. Genova, xxxv. p. 498, 1895).

ARANEUS ERESIFRONS, sp. n. (Plate XLI. figs. 3-3 b.)

Colour. Carapace reddish brown, blackish on the head-region, hairs whitish; mandibles blackish brown; sternum, labium, and maxillæ brown; legs with coxæ and trochanters reddish yellow, rest of legs reddish yellow, with the greater part of the femora and the distal end of the tibiæ blackish, hairs white; palpi yellowish red; abdomen nearly uniform cream-white on the upperside, with four sigilla showing as brown spots, sometimes with fine darker longitudinal lines on the posterior part and fine indistinct yellowish vertical lines at the sides; fore part of abdomen deep black, with a transverse white stripe; this black, becoming gradually paler, spreads backwards and downwards over the whole of the sides and lower surface of the abdomen as far back as the spinners, which are themselves brown; the area between the spinners and the epigastric fold a little darker and ornamented with four white spots, one on each side behind the lung-books, the others farther back and closer together in front of the spinners.

Head strongly elevated, convex from before backwards and from side to side. Ocular quadrangle much wider in front than behind; the anterior median eyes much larger than the posterior median and more widely separated, distance between posterior medians barely equal to their radius, distance between anterior medians nearly equal to their diameter, distance between anterior and posterior medians about equal to diameter of anterior; eyes of anterior line slightly procurved when viewed from the front, the centres of the medians about on a level with the upper edge of laterals, which are about their own diameter above the edge of the clypeus.

Mandibles armed with three posterior and three anterior teeth. Spines on legs few in number and black.

Abdomen voluminous, rounded, without shoulder-points, a little wider than long, widely rounded, not pointed posteriorly. *Vulva* when viewed from below forming a pair of pit-like depressions separated in the middle line by the scape, which, broad and wrinkled at the base, passes backwards, then takes an abrupt curve, the apical piece being bent at right angles to the basal portion.

Measurements in millimetres.—Total length 11; length of abdomen 8.5, width 9.

Loc. Taru.

The Museum has also received this species from the following localities in East Africa:—Karagesi (*Emin Pasha*); Mombasa (*W. E. Taylor*); Leikipia (*J. W. Gregory*). The specimen selected as the type is one of those from Karagesi.

In form and colouring, especially of the abdomen, this species closely resembles the Australian species *Epeira albida* of L. Koch (*Die Arachniden Austral.* i. p. 83, pl. vii. fig. 2), with which *Epeira locuples* of Butler (*P. Z. S.* 1879, p. 732, pl. lviii. fig. 2) from Madagascar is apparently identical. The form of the vulva in *A. eresifrons* is, however, quite different from that of *albidus*, and the latter has not the strongly elevated head characteristic of the former.

According to Simon's divisions of the genus *Araneus* this species falls into Section 3, except that the anterior line of eyes is slightly procurved rather than recurved.

ARANEUS BETTONI, sp. n. (Plate XLI. figs. 4, 4 a.)

Colour. Carapace mahogany-red, black at the sides and on the face, clothed with white hairs; mandibles yellow in front at base, black at apex and along their outer surface; palpi ochre-yellow, with patella, tibia, and tarsus infusate distally; legs variegated, femora mostly black, those of the 3rd and 4th legs with two yellow rings, one basal, the other submedian; of the 1st less distinctly annulate, reddish below and internally; patella black below, reddish brown above; tibiæ yellowish red, blackish at apex, that of 2nd leg also with a broad black basal patch below; protarsi yellow, black at apex; abdomen deep blackish brown above, with broad paler band along middle line; sides of abdomen lighter than upper surface,

yellowish brown, and ornamented below with jet-black irregular transverse stripes, which below become blended with the darker tint of the inferior surface, area between spinners and epigastric fold black; anterior spinners black, posterior reddish; coxæ reddish black; sternum black, with a pale narrow median line.

Carapace with cephalic region moderately elevated, only lightly convex above; carapace a little longer than upperside of tibia of 1st leg, its width just about equal to tibia of 2nd leg. Eyes of anterior line very slightly procurved, centres of medians on a level with upper edge of laterals; median quadrangle wider in front than behind; anterior medians about a diameter apart and a little farther from the posterior medians; posterior medians less than a diameter apart.

Mandibles with four anterior and three posterior teeth. Spines on legs numerous and strong.

Abdomen broader than long, voluminous, without shoulder-points, its anterior border widely rounded, its posterior widely ovate. *Vulva* consisting of a simple stout vertical rod, with its apex bent at right angles to the basal portion.

Measurements in millimetres.—Total length 16; length of carapace 6.5, of abdomen 10.5; width of abdomen 11.2; length of anterior leg 25, of posterior leg 23.

Loc. "88 miles inland from Mombasa." A single female.

Allied to *A. nauticus*, but much larger and with wider abdomen and the distal end of the vulva bent at right angles instead of nearly straight.

ARANEUS TARUENSIS, sp. n. (Plate XLI. fig. 5, and Plate XLIII. fig. 1.)

Colour. Carapace testaceous, infuscate laterally; mandibles, palpi, and maxillæ testaceous; sternum testaceous in the middle, brown at the sides; legs testaceous; femora of first three pairs with a fuscous patch at the distal end, of 4th pair with a median fuscous patch as well; 3rd and 4th legs also infuscate at distal end of patella and tibia and at the middle of protarsus and on tarsus, these patches less evident on legs of 1st and 2nd pairs; abdomen ochre-yellow above, speckled with minute red lines and spots, a distinct folium consisting of a zigzag black line on each side extending from the median sigilla to the apex; area between the four central sigilla divided by a narrow median black line, branching at the sides; anterior portion of abdomen with a sooty-black patch on each side continuous with the lighter blackish-grey tint of the lateral surface, lower surface ochraceo-fuscous, with a pair of large yellow spots behind the middle line in front of the spinners; hairs mostly white; spines on legs black at base, pale distally; hairs on sides of abdomen golden yellow or reddish.

Carapace shorter than 1st tibia, its width less than 2nd tibia, moderately elevated as in *A. bettoni*. Eyes of anterior line slightly recurved or very nearly quite straight; median quadrangle narrowed in front, longer than wide, but the eyes composing it

subequal in size; the anterior eyes a diameter apart, the posterior half a diameter. Mandible with 4 teeth in front and 3 behind.

Abdomen widely rounded in front, narrowly ovate behind, longer than broad, without distinct shoulder-points, but prominent in this region. *Vulva* formed on the same general plan as in the preceding species, though differing in structural details.

Measurements in millimetres.—Total length 11.5; length of carapace 5, of abdomen 8; width 7.

Loc. Taru. A single adult female.

Also allied to *A. nauticus*, but differing in the form of the vulva and in colour.

Genus CYRTOPHORA Simon.

CYRTOPHORA CITRICOLA (Forsk.).

Aranea citricola, Forsk. Descr. Anim. p. 86 (1775) (and all recent authors).

Loc. Taru.

Common throughout the tropics of the Eastern hemisphere.

Genus ARGIOPE Aud.

ARGIOPE NIGROVITTATA Thor.

Argiope nigrovittata, Thor. Öfv. K. Vet.-Akad. Forh. 1860, p. 300; Eug. Resa, Arachn. p. 31 (= *caudata* Blackw., and *suavissima* Gerst.).

Loc. Samburu, Taru.

ARGIOPE LOBATA (Pallas).

Aranea lobata, Pallas, Spicil. Zool. i. pt. 9, p. 46, pl. iii. figs. 14–15 (1772).

Loc. Samburu. A single immature female referable either to this species or to the closely allied *A. clathrata* C. Koch.

ARGIOPE AUROCINCTA, sp. n. (Plate XLI. figs. 6, 6a, and Plate XLII. fig. 11.)

Colour. Carapace ochre-yellow, with radially arranged fuscous spots, covered with silver-white hairs; mandibles and palpi flavous; maxillæ and labium flavous, black at the base; sternum with a broad median flavous band with radiating yellow spots, black at the sides; legs yellow, strongly ringed with black; coxæ with two black spots, femora with three broad black bands, patellæ with a dark distal band, tibiæ with a basal, a median, and an apical black band, protarsi also with three bands, tarsi dark, basally flavous. *Abdomen* ferruginous along the anterior border, with three transverse silvery bands with straight anterior and sinuous posterior border—the anterior just behind the shoulder-points, the median in front of the middle of the upper surface, the posterior behind the middle, the bands scarcely extend on to the sides, the median and posterior ending in a slight enlargement; the median and posterior are defined in front by a narrow dark border and behind

by a transverse black stripe; the areas between these bands rusty red, the whole of the posterior third of the upper surface also rusty red; sides and lower surface deep black, marked with small white spots and furnished with a pair of white internally and externally digitate stripes, passing from the epigastric fold to a point on each side of the red mamillæ; area between the mamillæ and the apex of the abdomen deep black.

Carapace heart-shaped, broad, considerably broader than long, its length equal to tibia of 2nd leg, longer than tibia of 4th and than patella and tibia of 3rd, its width equal to length of 4th protarsus.

Legs not plumose, without spiny band on the posterior femora.

Abdomen truncate in front, with distinct shoulder-points, oval behind, with evenly convex margins converging to a point, in no sense dilated behind, with borders not lobate, about one-fourth longer than wide. *Vulva* consisting of a smooth upstanding posteriorly narrowed tubercle, the posterior border of which is mesially grooved and behind forms a wide septum between the normal arched spaces.

Measurements in millimetres.—Total length 14; length of carapace 5, width 6; length of abdomen 10, width 7.5; length of 1st leg 23, of 2nd 23, of 3rd 15, of 4th 21.

Loc. Samburu. A single adult female.

In the form of the abdomen this species approaches many of the Oriental species of the genus *Argiope* (e. g. *etherea* Walck.), but differs from all with which I am acquainted in the pattern of the abdomen &c.

Genus ARGYROPEIRA Emerton.

ARGYROPEIRA UNGULATA (Karsch).

Meta unguolata, Karsch, Zeitschr. gesammt. Naturwiss. lii. p. 834 (1879).

Loc. Taru.

This species, recorded originally from the Loango coast, is widely distributed throughout tropical Africa.

? Genus SALASSINA Simon.

SALASSINA FORMOSA (Karsch).

Cyclosa formosa, Karsch, Zeitschr. gesammt. Naturwiss. lii. p. 835 (1879).

Loc. Samburu and Taru.

Recorded from the Loango coast by Karsch. The British Museum also has examples from the Camaroons (*H. H. Johnston*).

Genus POLTYS C. Koch.

POLTYS CORTICOSUS, sp. n. (Plate XLII. figs. 12, 12 a.)

Colour. Thoracic region of carapace deep reddish brown, cephalic yellowish white; mandibles nearly black; sternum, coxæ, and palpi

tawny brown, femora of anterior legs deep reddish, with a steel-blue anterior distal band; femur of 3rd leg with the steel band on the posterior side; of 4th almost entirely steel-blue, the distal end only pale; patella of 2nd, 3rd, and 4th brown below, of 1st paler coloured; tibiae with a black or deep brown spot at the distal end below, also with a median spot, stronger on those of the 2nd and 3rd pairs; protarsi with two broad bands on the distal half of the lower surface, which on the 3rd and 4th pairs fuse into a continuous broad black band; tarsi black at the distal end below; upperside of legs from patella to tarsus clothed with greyish-yellow hairs, indistinctly variegated with brownish spots, which take the form of definite bands on the tarsi and protarsi and on the distal end of the tibia and patella of the 4th and less distinctly so of the 3rd; epigastric region of abdomen and an area of corresponding size above and at the sides of the pedicel black; upperside of abdomen rusty brown, with a deep chocolate patch in the centre; the sides and tubercles silvery yellow, variegated with lights and shades; lower side of abdomen behind epigastric fold yellowish brown.

Carapace a little longer than patella and tibia of 3rd leg, a little shorter than those of 4th; ocular quadrangle nearly square, its length considerably less than height of clypeus.

Abdomen nearly parallel-sided, with rounded posterior end, moderately high, its upper surface tolerably flat in the middle but beset with varying sized tubercles, furnished anteriorly with three large tubercles, one in the middle line, and a considerably larger one on each side, which are themselves beset with smaller tubercles.

Measurements in millimetres.—Total length 12; length of carapace 6.5, width 5; length of 1st leg 22, 2nd 21, 3rd 15, 4th 18; length of abdomen from base of median tubercle 9, width 7, height from lower side of pedicel to base of lateral tubercle 6.

Loc. Maziwa Mitatu in the Taru desert.

This species falls into the section of which *P. illepidus* C. Koch is an example, and is perhaps allied to the W. African *P. monstruosus* Simon, which is unknown to me.

Genus CÆROSTRIS Thorell.

CÆROSTRIS NODULOSA, sp. n. (Plate XLI. fig. 7.)

Colour. Carapace black, or reddish brown in younger specimens, its posterior slope reddish brown; cephalic region covered with a clothing of whitish hairs, intermixed here and there with yellow or mostly yellow, mottled greyish patches at the sides and along the middle line; mandibles black or brown, covered with yellowish-brown hairs intermixed with white; upperside of legs from patella to tarsus covered with silvery white hairs, variegated with patches of yellow or yellowish grey, the darker patches being traceable upon the distal end of the patella, tibia and protarsus, and even the middle of the tarsus; on the 3rd and 4th protarsus the darker patch is in the middle of the segments; femora naked, except at the distal end, and in maturer forms steel-blue in colour;

legs banded below almost as in *C. sexcuspidata* (Fabr.), the black band on the protarsus of 1st and 2nd not extending to apex of segment as it does in *mitralis*, and not or hardly wider than the apical white spot on the protarsus of the 4th. Abdomen coloured below as in *mitralis*, a uniform greyish-brown with a narrow transverse stripe behind the epigastric fold, the upperside covered with a clothing of greyish-white hairs, variegated at the sides and behind with brown patches and lines, sometimes with a transverse mesially interrupted brown stripe behind the anterior of the median sigilla, and with sometimes a median brown band extending to the spinners from the posterior pair of large sigilla.

Carapace with its dorsal and lateral tubercles subequal in size; the length of the carapace equal to protarsus and half the tarsus of 1st leg, almost equal to protarsus and tarsus of 4th; width of the head a little less than length of carapace.

Abdomen about as broad as long; tubercles very variable in size, but the same in number as in *C. mitralis*; of the six forming the anterior series those constituting the median pair are closer together than either is to the adjacent tubercle on its outer side; the three shoulder-tubercles sometimes raised into a conspicuous hump, sometimes produced into a longish pointed process, sometimes quite small, the median tubercles between them also either scarcely projecting above the level of the integument or forming a pointed conical process; the four posterior tubercles distinct, but not large.

Vulva consisting of a black tubercle, the anterior half of which is deeply grooved mesially; the posterior half excavated, the excavation divided by a median longitudinal ridge; the posterior rim of the excavation mesially elevated, its anterior rim formed by the posterior edge of the anterior sclerite, forming two arches; the little spinuliform processes which arise from the front edge of the vulva are widely separated at the base, are directed backwards with a slight outward curvature, but their tips do not reach the anterior arched border of the excavation.

♂. Much smaller than ♀; the tubercles of the carapace small, especially the lateral; legs red in colour and less distinctly banded than in ♀; upperside of abdomen subcircular with truncate anterior border, convex from before backwards, without tubercles, with a large anterior median and three pairs of large sigilla arranged in two longitudinal series, also with marginal sigilla.

Measurements in millimetres.—♀. Total length 22; length of carapace 9; width of head 8.5; length of abdomen 16, width 16.5; length of 1st leg 29, of 4th 27.

♂. Total length 7; width of head 3.5; length of abdomen 5.5, of 1st leg 13.5, of 4th 11.

Loc. Samburu, Taru, and Marago-ya-Fundi (in the Taru desert).

Perhaps identical with the species which Gerstäcker identified as *C. mitralis* Vinson (Von der Decken's Reisen etc. iii. pt. 2, p. 491), or perhaps with that from Shoa determined as *C. mitralis* by Pavesi (Ann. Mus. Genova, xx. p. 8); but certainly

different from Madagascar examples in the British Museum which I refer to *C. mitralis*. It also differs apparently from *C. rugosa* Karsch, from Inhambane in Mozambique (Mon. Ak. Wiss. Berlin, 1878, p. 323, pl. i. fig. 8), at least in the form of the vulva, which Karsch declares to resemble in his species that of *C. mitralis*; and lastly, judging from the description of *C. simata* Bösenberg & Lenz, from Quilimane and Pangani (Jahrb. Hamb. Anst. xii. p. 46, pl. ii. fig. 27, 1896), it differs from that species at least in the following particulars: the equality in size between the dorsal and lateral tubercles of the carapace, the distinctness of the dark naked lines upon the patellæ and tibiæ of the legs, and the absence of the cherry-red patch of colour by the vulva, which was present in all the examples of *simata*. The figures of the vulva of the last-named species afford scarcely any help towards its identification.

Genus GASTERACANTHA Sundevall.

GASTERACANTHA RESUPINATA Gerstäcker.

Gasteracantha resupinata, Gerstäcker, Von der Decken's Reisen in Ost-Afrika, iii. 2, p. 490, pl. xviii. fig. 8.

Loc. Maziwa Mitatu and Machuma (Taru desert).

This species is sometimes cited as synonymous with *G. falcicornis* of Butler, which has priority. The two are, however, I think distinct, the red bands on the abdomen in *resupinata* being absent in *falcicornis*.

GASTERACANTHA TABULATA Thor.

Gasteracantha tabulata, Thorell, Öfv. K. Vet.-Akad. Forhandl. xv. p. 303 (1859); id. Eugenes Resa, Arachnida, p. 23.

Loc. Machuma, Maziwa Mitatu (Taru desert).

Extends as far to the south as the Transvaal and Natal.

Family ERESIDÆ.

Genus STEGODYPHUS Simon.

STEGODYPHUS LINEIFRONS, sp. n. (Plate XLII. fig. 13.)

Colour. Carapace castaneous, thickly clothed with white hairs intermixed with others of a yellower hue; a narrow black transverse stripe running from the antero-lateral eye on each side to a point on a level with the posterior median eye; upper basal half of mandibles clothed with white hairs, lower or distal half with blackish-brown hairs; legs clothed with yellowish-white hairs, the inner and under side of the femur and tibia of the 1st leg deep velvety black, and the inner surface of the femur and the inner half of the tibia of the 2nd also velvety black; tarsi and protarsi in part infuscate; a blackish-grey patch on the posterior (inner) side of the 4th protarsus; entire upperside of abdomen ochre-yellow, covered with short white hairs, the lower side variegated with pale brown, with a patch of black hair upon the vulva and black shining mamillæ.

Carapace equal to patella and tibia and almost half protarsus

of 1st leg and a little longer than patella, tibia, and half protarsus of 4th, longer than protarsus and tarsus of 1st, than tibia, protarsus, and tarsus of 2nd, and than patella, tibia, protarsus, and tarsus of 3rd, and just about equal to tibia, protarsus, and tarsus of 4th; width of cephalic region exceeding length of 1st protarsus and just about equal to tarsus and protarsus of 4th.

Vulva as in figure.

Measurements in millimetres.—Total length 15; length of carapace 7·3; width of head 4·3; length of 1st leg 16, of 2nd 12, of 3rd 10, of 4th 14·5.

Loc. Mbuyuni. A single adult female.

Evidently nearly related to *Stegodyphus africanus* of Blackwall from the Zambesi region (Ann. Mag. Nat. Hist. (3) xviii. p. 453, 1866), but apparently differing in having the hairs on the upper half of the mandible white instead of reddish yellow, in the presence of the narrow dark transverse line on the face, and in the absence of a dark sinuous stripe on each side of the middle line of the dorsal side of the abdomen. From *S. mimosarum* Pavesi (Ann. Mus. Genova, xx. p. 81, 1884), from Shoa, *lineifrons* also differs in the absence of the abdominal bands and the presence of the facial line, and also apparently in the coloration of the 2nd leg.

STEGODYPHUS BETTONI, sp. n.

Colour. Carapace clothed with black hair, with a marginal border of white hairs extending from the antero-lateral eye, and a wide white, irregularly oblong, patch occupying the upper and posterior portion of the cephalic region, and breaking up in front into narrow stripes, of which one on each side extends forwards as far as the posterior median eye; mandibles black, their basal half marked with a transverse white stripe, separated by a space about equalling its own width from the edge of the clypeus: legs variegated with incomplete rings of brown and white; femora of 1st and 2nd blacker, with snow-white patches: abdomen testaceous, covered above with yellow hairs, without clearly defined longitudinal black bands; black below, and variegated with white patches.

Length and width of carapace as compared with legs almost the same as in the preceding species, the legs being slightly longer.

Measurements in millimetres.—Total length 11; length of carapace 4; width of head 2·3; length of 1st leg 8·5, of 2nd 6·5, of 3rd 5·1, of 4th 8.

Loc. Samburu.

Although the single example of this species that was obtained is an immature female, I have not hesitated to describe it, the females of this genus being generally readily recognizable by colour-characters; and since these characters are not, within my experience, subject to much variation with growth, there is no reason for supposing that the adults will differ from the immature type specimen of the species in any important character but size.

S. bettoni may apparently be recognized from the rest of the known tropical African species by the colouring of the carapace and mandibles.

Family PISAURIDÆ.

Genus TETRAGONOPHTHALMA Karsch.

TETRAGONOPHTHALMA STUHLMANNI Bösenb. & Lenz.

Tetragonophtalma stuhlmanni, Bösenb. & Lenz, Jahrb. Hamb. Anst. xii. p. 37, pl. ii. fig. 19.

Loc. Taru and Samburu.

Two male examples belonging to this or to a nearly allied species.

Genus THALASSIUS Simon.

THALASSIUS MARGARITATUS, sp. n. (Plate XLI. fig. 8.)

Colour. Carapace a dark mahogany-brown, with a broad, completely marginal yellowish-white band, which in front runs up to a point on a level with the anterior median eyes: abdomen a rich olive-brown above, ornamented on each side with a broad yellow lateral stripe, geniculate at its posterior end where it embraces the abruptly narrowed posterior termination of the dark coloured field of the upper surface; four yellowish-white spots on the upper (inner) margin of each stripe, the posterior spot the largest and situated just in front of the geniculation of the lateral band; lateral surface below the band greyish white in front: legs and lower surface a tolerably uniform yellowish or greyish brown.

Carapace a little shorter than tibia 1, and about as long as protarsus 1, its width a little shorter than tibia 3; ocular quadrangle a little longer than wide, parallel-sided, the eyes composing it subequal; clypeus equal to about once and a half times the length of the quadrangle; anterior lateral eye nearer to the anterior median than to the posterior lateral.

Legs 4, 1 and 2, 3; patella and tibia of 1st distinctly shorter than of 4th, scarcely exceeding those of 3rd.

Abdomen truncate in front, pointed behind, broadest just behind the middle.

Measurements in millimetres.—Total length 21; length of carapace 9, width 8; length of 1st leg 33, of 2nd 34, of 3rd 32.5, of 4th 38.5; patella and tibia of 1st 12, of 4th 13.5.

Loc. Samburu and Taru.

Differing from the rest of the African species with which I am acquainted in the pattern of the abdomen and the marginal white thoracic band.

Family CTENIDÆ.

Genus CTENUS Walck.

CTENUS CARSONI F. Cambr.

Ctenus carsoni, F. Cambr. Proc. Zool. Soc. 1898, p. 24, pl. iii. figs. 4, 5.

Loc. Taru and Mgana.

Apparently widely distributed in East Africa.

Family HETEROPODIDÆ.

Genus HETEROPODA Latr.

HETEROPODA VENATORIA (Linn.).

Loc. Changamwe.

Introduced by human agency throughout the world, originally from the Oriental region.

Genus SPARASSUS Walck.

SPARASSUS BICORNIGER, sp. n. (Plate XLI. fig. 9.)

Colour of carapace, mandibles, sternum, coxæ, and maxillæ a uniform bright ochre-yellow, the sternum rather paler than the coxæ and carapace; legs of the same tint, but with the femora rather thickly spotted below; tarsus and tibial spines of palp black; hairy clothing of legs and carapace, where present, of a silvery white; abdomen damaged, but distinctly spotted above, the sides variegated with yellowish hairs.

Carapace about equal to length of 4th tibia, very slightly longer than wide, strongly convex; posterior line of eyes straight, the eyes subequal, the medians nearer together than either is to the corresponding lateral; ocular quadrangle longer than wide: eyes of anterior line straight, larger than those of the posterior, subequal in size and subequally spaced; distance between the medians less than a diameter, medians about their own diameter from edge of clypeus.

Legs 2, 1, 4, 3; patella and tibia of 1st longer than of 4th; protarsi of 1st, 2nd, and 3rd scopulate only in the distal third of their length, 4th not scopulate; patellæ unspined, spines on lower side of tibiæ and protarsi 2, 2, on upperside of tibia 1, on upperside of femora in the middle 2.

Palp with tibia and patella subequal in length; tibia much thickened below at its distal end, armed externally with a long, straightish, slightly clavate process, which considerably exceeds the tibia in length and gives off near its base in front a thinner curved pointed process nearly equal to the tibia in length; tarsus rather longer than patella and tibia, with a narrow stalk-like neck and a posterior external angular expansion, its inner margin evenly convex, gradually narrowed to the tip.

Measurements in millimetres.—Total length 10; length of carapace 4·8, width 4·3; length of 1st leg 22, of 2nd 24, of 3rd 17·8, of 4th 20.

Loc. Ndi, Weiss Road.

This peculiar species is sufficiently characterized by the structure of its double tibial apophysis of the palp.

Order SOLIFUGÆ (SOLPUGAS).

Family SOLPUGIDÆ.

Subfamily RHAGODINÆ.

Genus RHAGODES Pocock.

RHAGODES ORNATUS (Poc.).

Rhax ornatus, Poc. Ann. Mag. Nat. Hist. (6) xvi. p. 93, pl. iv. fig. 2.

Loc. Maziwa Mitatu and Samburu.

Described from Mombasa.

Subfamily SOLPUGINÆ.

Genus SOLPUGA Licht.

SOLPUGA SEMIFUSCA, sp. n.

Colour. Palpi and limbs a uniform reddish or ochre-yellow; upper surface of mandibles and cephalic plate a very deep olive-brown or black; sides of the mandibles yellow, contrasting sharply with the dark tint of the upper surface; the whole of the upper-side of the abdomen dark; the whole of the lower surface pale.

Head-plate: width a little less than length of tibia of palpus or of 4th leg, exceeding the 4th protarsus by about one-third of the tarsus, less than protarsus and tarsus of palp by half the tarsus.

Dentition of *mandible* as in *S. brunnipes*, the small tooth on the upper jaw following the second indistinctly double.

Measurements in millimetres.—Total length (including mandibles) 53, without mandibles 40; width of head 10·6; length of palpus 35, of 1st leg 29, 2nd leg 26, 3rd leg 33·5, 4th leg 54; tibia of palp 11, its tarsus and protarsus 12; tibia of 4th leg 11, protarsus 10.

Loc. Voi (*type*) and Samburu.

Without knowing the male characters it is not possible to satisfactorily determine the position of this species. In general aspect it is much like *brunnipes* of Dufour; but differs from the specimens of that species known to me—namely, one example from Algeria and one from Somaliland (*Donaldson Smith*)—in having the head and upper surface of the jaws of a uniform blackish tint, *brunnipes* being uniformly ochre-brown in these parts.

S. merope of Simon (Ann. Soc. Ent. France, 1879, p. 112), from Zanzibar, may be allied to this form; but I know nothing of the proportion of the limb-segments to the head. Possibly the type of *merope* is young, but, if not, the species is much smaller than *semifusca*, measuring only 26 mm. in total length; and, lastly, the 4th legs are described as being infusate at least in part.

SOLPUGA ZEBRINA, sp. n.

So closely allied to *S. sericea* Pocock, from Gadzima on the Umfuli River in Mashonaland, 4200 ft. alt. (Ann. Mag. Nat.

Hist. (6) xx. p. 260, fig. 4), that no detailed description is necessary; the principal difference lying in its much smaller size, the adult male measuring with the mandible only 18 mm., whereas *S. sericea* is as much as 30. Moreover, although the tergal plates of the abdomen in *zebrina* are narrowly margined with black with a broad black median dorsal band, there is on each side of the latter a conspicuous broad yellow stripe, each being almost half the width of the median black stripe. In *S. sericea* the corresponding yellow stripe is very narrow in comparison.

Measurements in millimetres.—♂. Total length of trunk 15, with mandibles 18; width of head 3; length of palp 17, of 1st leg 16, 2nd leg 13, 3rd leg 17.5, 4th leg 29; tibia, protarsus, and tarsus of palp 5.5; tibia of 4th leg 5, protarsus 5.5.

Loc. Maziwa ya Tagari, in the Taru desert.

Two male examples.

Genus ZERIASSA Pocock.

Zeriassa, Pocock, Ann. Mag. Nat. Hist. (6) xx. p. 255 (1897).

ZERIASSA SPINULOSA, sp. n. (Plate XLII. fig. 15.)

Colour. Upperside of mandible, head, thorax, and abdomen a uniform reddish or earthy brown; two indistinct darker stripes on the mandible; ocular tubercle black, only the tips of the fangs reddish brown; palp with tibia, protarsus, and distal third of the femur black; tarsus and basal two-thirds of the femur clear yellow; the joints between the femur, tibia, and protarsus slightly paler; 1st and 2nd legs yellow, with the exception of the fuscous distal end of the femur; 3rd and 4th legs also with the tibia distally black and the femur lightly infuscate, the rest of these limbs pale; lower surface of thorax and abdomen pale.

Head-plate equalling in width about two-thirds the length of the tibia of the palp and five-sixths the length of the protarsus of the 4th leg, as long as the tibia and one-third of the protarsus of the 3rd leg; studded with spinules; ocular tubercle prominent, high and wide.

Mandibles inflated, abruptly narrowed at the base of the fang, armed with longish spines above, the upper fang projecting far beyond the base of the flagellum, armed with a series of seven triangular but not long teeth, the first very small, placed a long distance behind the tip of the fang and close to the second, which is large and just below the base of the recurved portion of the flagellum; third tooth small, nearer to the fourth, which is also large, than to the second, the remaining three small and equally spaced; one small tooth on the inner side nearly on a level with the seventh tooth of the outer series; lower fang armed with three distinct teeth, the first and third subequal, the second smaller and nearer the second.

Flagellum with high, convexly rounded membranous portion: the recurved terminal portion short, scarcely surpassing the membranous portion; on the inner side of the upper fang are a couple of stout spines lying below the flagellum.

Palpi—femora clavate, furnished with a few short spines and short hairs; tibia narrower at the base, armed below throughout its length with many short spines; protarsus distally narrowed, armed below, like the tibia, with many short spines. In addition to the normal spine-armature, there are a few longish spines on the upperside of the basal segments of the legs.

Tergal plates of abdomen and of thorax beset with short spines, of which there is a distinct posterior row.

♀. Not very different from the male in length of limbs, size of mandibles, &c.; but with shorter malleoli; mandibles and head spiny; thorax, abdomen, tibia and protarsus of palp, and basal segments of legs not spiny; mandibles strongly toothed, second tooth twice as long as the first and twice as long as broad, third and fifth teeth small and subequal, fourth tooth large, but shorter than the second; inner row of teeth consisting only of two, one in the same position as in the male, the other considerably lower.

Measurements in millimetres of type (♂).—Total length of trunk 14, with mandibles 17·8; length of palp 19, of 1st leg 12, of 2nd leg 11·5, of 3rd leg 17, of 4th leg 26; tibia of palp 6, protarsus and tarsus 6; tibia of 4th leg 6, protarsus 5; width of head-plate 4·5.

♀. Total length of trunk 16, with mandible 21; width of head 4·8; length of palp 18, of 1st leg 11, of 2nd 12, of 3rd 15, of 4th 26; tibia of palp 6, protarsus and tarsus 5·5; tibia of 4th leg 5·5, protarsus 4·5.

Loc. Maziwa Mitatu in the Taru desert (*type*); examples also obtained at Machuma in the Taru desert, Mbuyuni and Ndi (Weiss Road).

The two known species of this genus may be readily distinguished as follows:—

- a. Length of trunk 25 mm.; terminal fang of upper jaw projecting a very short distance beyond the flagellum, its second tooth much larger than the rest; a row of 5 stout spines near the base of the flagellum on the inner side; filiform terminal part of flagellum long, far surpassing the membranous basal portion; head, mandibles, upper surface of body, and bases of limbs studded with stout bristles, not spines; femora and tibiae of posterior legs black..... *bicolor* Poc., ♂.
- b. Length of trunk 15 mm.; terminal fang of upper jaw far surpassing flagellum, the second tooth not larger than those behind it; only two spines near the base of the flagellum on the inner side; filiform portion of flagellum scarcely surpassing the membranous basal portion; head, mandibles, and dorsal surface of trunk studded with spines; posterior legs with only the distal end of the femur black..... *spinulosa*, sp. n.

Genus BITON Karsch.

BITON TIGRINUM, sp. n. (Plate XLII. figs. 14, 14 a.)

Colour reddish yellow, variegated with deeper brown; head-plate pale in its middle third, brown at the sides, tubercle black;

mandible with two indistinct fuscous stripes above; abdomen trilineate, each tergite marked with a median spot and a marginal spot on each side, the intervening pale area on each side about twice the width of the median spot; palpi with tarsus entirely pale, tibia deep brown, patella paler brown, its distal end and the adjacent end of the tibia narrowly pale; femur very lightly brownish distally; 1st and 2nd legs pale, 3rd with femur and patella lightly brownish (legs of 4th pair absent).

Head-plate and mandible covered with a clothing of short hairs intermixed with a few bristles; the former a little excelling in width half the length of the tarsus and protarsus of the palp.

Palpi long, as long as the body and mandibles; the tibia furnished with long bristles; the protarsus with five pairs of longish spines, those at the base of the segment setiform.

Mandibles elongate; the upper fang slightly sinuous, lightly concave above, rather strongly convex below, then narrowed at the point; the teeth arising rather far back, nearly as far back as the base of the flagellum; the first, second, and fourth long and nearly cylindrical but pointed; the third minute, lying close to the base of the fourth; the rest, three in number, forming the outer series, triangular; the inner basal series also three in number, sharp, the median of the three much the smallest; lower fang long, armed with two strong triangular teeth, and a minute one at the base of the first of these.

Flagellum membranous, broad, laminate, and incurled at the base, then passing into a slender terminal portion which passes back and rests on the head at the side of the ocular tubercle.

Measurements in millimetres.—Total length (including mandible) 15; length of mandible 4; width of head 3; length of palp 15, its tibia 5; tarsus and protarsus 5.5.

Loc. Samburu.

The absence of the 4th leg makes the generic position of this species a little doubtful. It may perhaps prove to be the male of either *B. brunripes* or *B. fuscipes* from Somaliland, but is equally likely to be distinct from both.

GENUS CEROMA Karsch.

CEROMA VARIATUM, sp. n. (Plate XLII. fig. 16.)

Colour. Head-plate yellowish, irregularly clouded at the sides with brown, pale quite in the middle, tubercle black; mandibles yellow, with two faint brown stripes; palpi with tibia, protarsus, and tarsus deep brown above, paler below; abdomen with three black bands, each tergite ornamented with a median and a marginal black spot; the yellow area on each side about three times the width of the median stripe; legs yellow, the posterior two pairs lightly brownish.

Differing from *C. johnstoni*, from Nyasaland¹, in having the

flagellum much longer and projecting back on to the head some distance past the ocular tubercle (in *johnstoni* it only reaches the tubercle), and in the much greater thickness of the upper fang, which though pointed at the apex is strongly elevated and convex above; moreover there is a distinct notch just in front of the first tooth; in the lower fang there is one large rounded tooth showing indistinct division into three, the posterior of which stands up as a triangular denticle. In *johnstoni*, this triangular tooth is relatively very much larger, and the other two are much smaller and more distinct; and in the upper jaw the terminal fang is slender (it is represented as too thick in fig. 1, p. 254, of my paper quoted above) and is lightly curved.

The legs and palpi of this species are also a little longer than in *C. johnstoni*.

Measurements in millimetres.—Total length 16; length of mandible 4; width of head 3·8; length of palp 12, its tibia 4, tarsus and protarsus 5; 4th leg 19, its tibia 5, protarsus 3·5.

Loc. Samburu. A single male example.

The type of this species may prove to be the male of *C. ornatum* of Karsch, based upon a female 22–23 mm. long from Masailand.

EXPLANATION OF THE PLATES.

PLATE XLI.

- Fig. 1. *Pterinochilus spinifer*, sp. n., ♂, p. 502. Palpal organ, external view.
 1 a. " " Anterior leg.
 2. *Pisenorodes höhneli* (Sim.), ♂, p. 505. Distal segments of palp, external view.
 2 a. " " Anterior leg.
 2 b. " " Tibial spur of anterior leg.
 3. *Araneus eresifrons*, sp. n., ♀, × 2, p. 509.
 3 a. " " Vulva from the side.
 3 b. " " Vulva from below.
 4. " *bettoni*, sp. n., ♀, × $\frac{2}{3}$, p. 510.
 4 a. " " Vulva from the side.
 5. " *taruensis*, sp. n., p. 511. Vulva.
 6. *Argiope aurocincta*, sp. n., p. 512. Vulva from below.
 6 a. " " Vulva from behind.
 7. *Cærostris nodulosa*, sp. n., p. 514. Vulva.
 8. *Thalassius margaritatus*, sp. n., ♀, × $\frac{3}{2}$, p. 518. Extended on a reed.
 9. *Sparassus bicorniger*, sp. n., p. 519. Tibial processes of palp of male.

PLATE XLII.

- Fig. 10. *Araneus taruensis*, sp. n., ♀, × 2, p. 511.
 11. *Argiope aurocincta*, sp. n., ♀, × 2, p. 512.
 12. *Poltys corticosus*, sp. n., p. 513. Lateral view of cephalothorax and abdomen.
 12 a. " " Anterior view of cephalothorax and abdomen.
 13. *Stegodyphus lineifrons*, sp. n., p. 516. Vulva.
 14. *Biton tigrinum*, sp. n., ♂, × 3, p. 522.
 14 a. " " Inner surface of mandible.
 15. *Zeriassa spinulosa*, sp. n., p. 521. Inner view of mandible of male.
 16. *Ceroma variatum*, sp. n., p. 523. Inner view of mandible of male.

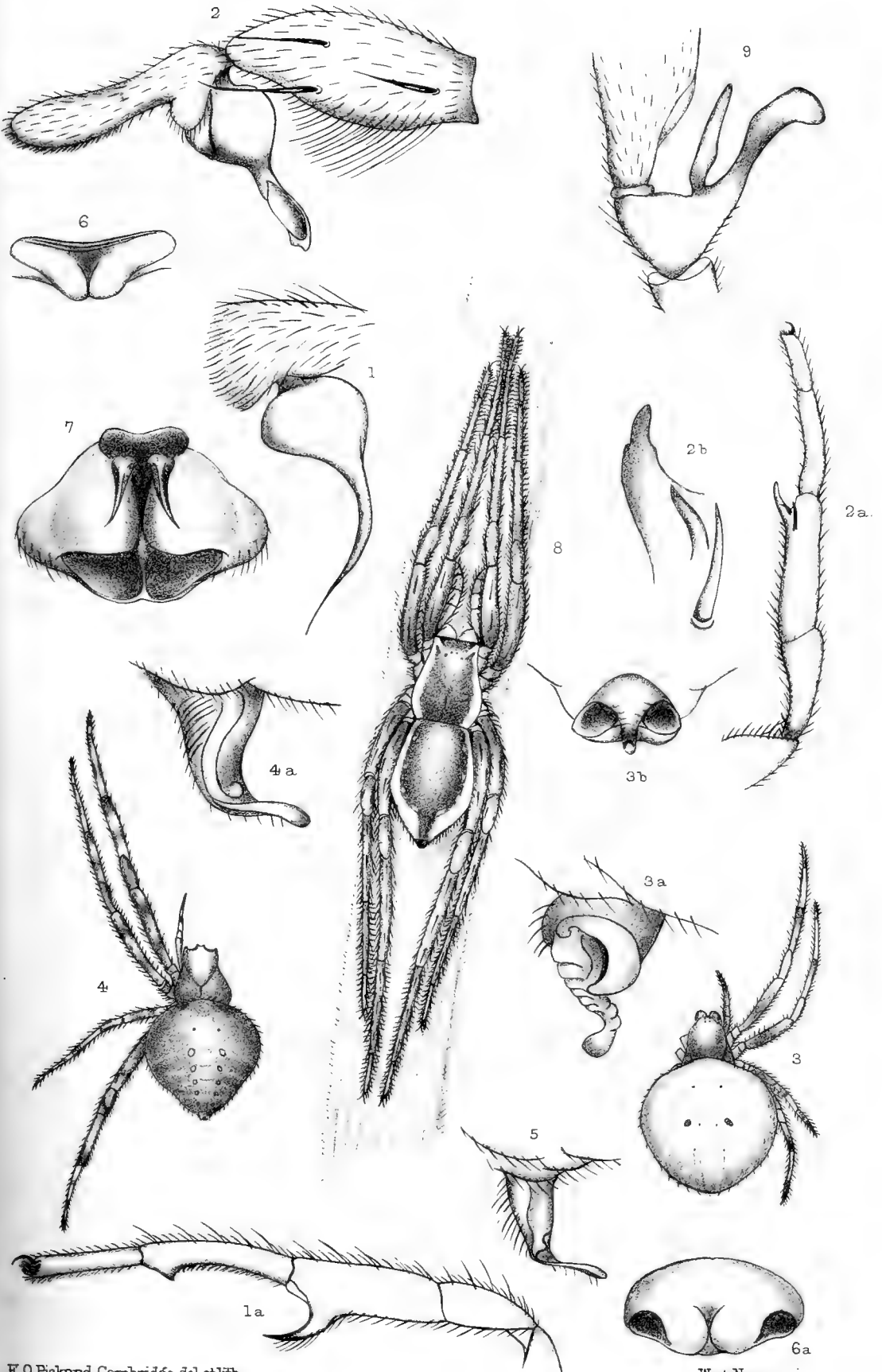

F. O. Pickard-Cambridge del et lith.

West, Newman imp.

British-East-African Arachnida.



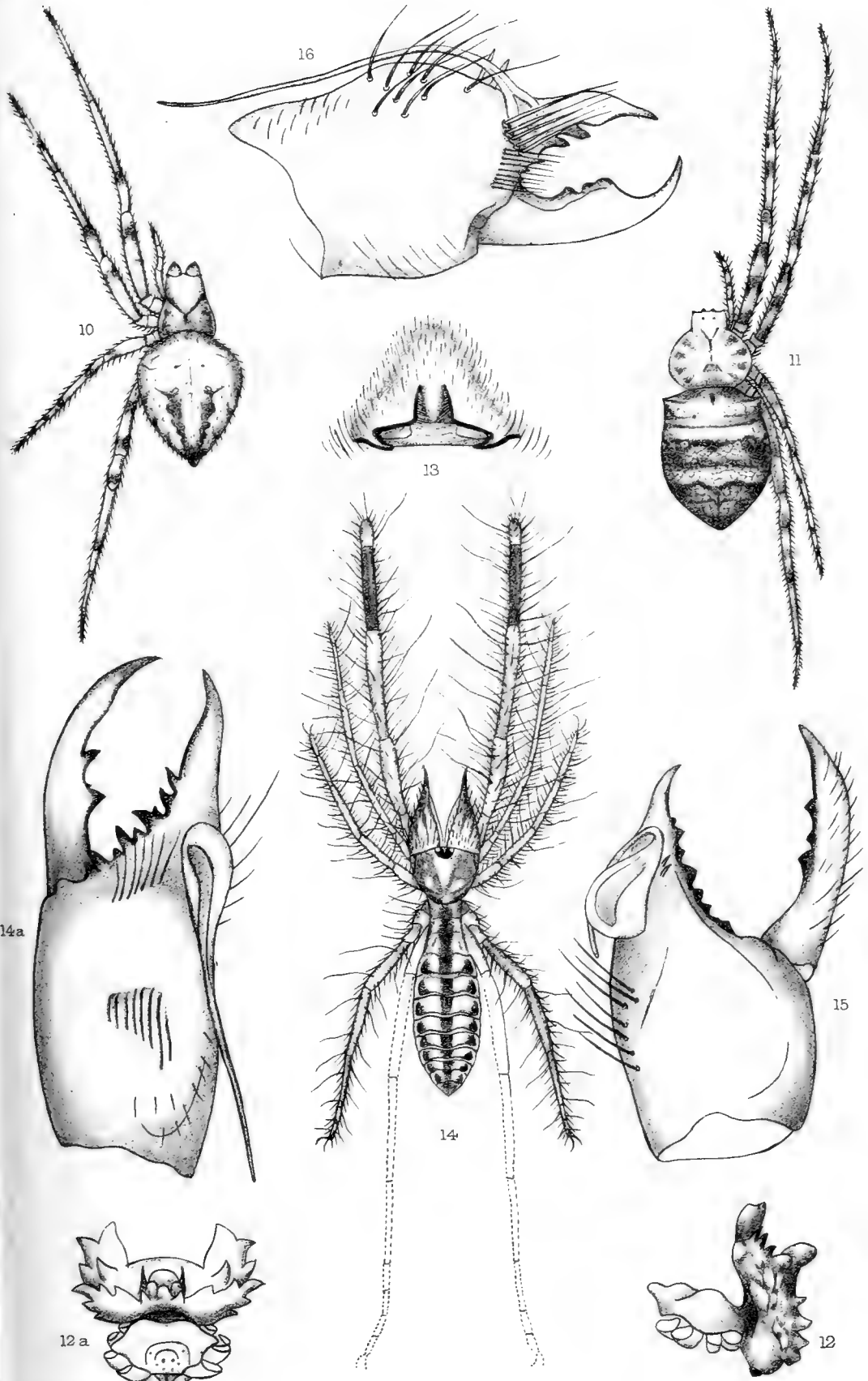

F. O. Fickard. Cambridge del. et hth.

West, Newman imp.



2. On the Fungid Corals collected by the Author in the South Pacific. By J. STANLEY GARDINER, M.A., Gonville and Caius College, Cambridge¹.

[Received May 31, 1898.]

(Plates XLIII.—XLV.)

The present paper forms the third of the series on the corals collected on the reefs of Funafuti, Rotuma, and Fiji. In it 48 specimens are dealt with, of which 39 have been referred to 15 known species, while 6 species have been described as new. It is proposed to absorb the genus *Tichoseris* into *Pavonia* and the genera *Mæandroseris*, *Coscinarcea*, and *Plesioseris* into *Psammocora*.

Genus SIDERASTRÆA.

Siderastræa, Blainville, Dict. des Sci. Nat. t. lx. (1830).

Siderina, Dana, Zooph. p. 218 (1846).

Siderastræa, Duncan, Journ. Linn. Soc., Zool. xviii. p. 134 (1885).

I have referred two specimens to this typical West-Indian genus, after having compared them carefully with a number of specimens of the genus in the British Museum.

1. SIDERASTRÆA CLAVUS Dana. (Plate XLIV. fig. 1.)

Pavonia clavus, Dana, Zooph. p. 332, pl. xxiv. fig. 4.

The largest of the two specimens which I have referred to this species is a much swollen branch, 11 cm. high by 4 cm. in diameter at the base and 9 cm. at the somewhat lobed and twisted apex. The calices at the sides, which are from 1.5–2.5 mm. in diameter, are separated by a dense theca, over which the septa are continuous (Pl. XLIV. fig. 1). The latter are typically 24 in number, alternately large and small, the primary² scarcely distinguishable from the secondary; commonly, however, their number is considerably reduced, owing apparently to the fusion together of several at the angles, where three or more calices meet. In the axial fossa is a small, low, often laterally compressed columella. The calices of the summit are much smaller than those of the sides, being generally less than 1.5 mm. in diameter. Their septa are relatively thinner with wide interseptal loculi, and the thecæ are generally very distinct, the calices often being joined to one another solely by costæ.

The smaller specimen is a nodule 3 cm. high obtained from the reef close to the larger. Its apical calices have 6 large septa fused with the columella and 6 smaller and narrower septa. The thecæ of neighbouring calices are thin and do not fuse, being joined merely by costæ. Deeper in the corallum, in sections, the thecæ

¹ Communicated by W. BATESON, F.R.S., F.Z.S. For former papers see P. Z. S. 1897, p. 941, and 1898, p. 257.

² In this paper, unless otherwise precisely stated, the first six septa are known as the primary, and the second six as the secondary.

and costæ can be seen to be much thicker, almost obliterating the intercostal spaces and forming a dense imperforate wall.

Rotuma; rim of reef.

Genus FUNGIA.

Fungia, Dana, Zooph. p. 318 (1846).

Fungia, Duncan, Journ. Linn. Soc., Zool. xviii. p. 141.

The genus *Fungia* is represented in the collection by 8 large anthocyathi, and 44 trophozooids and anthoblasts.

There were no living specimens obtained from Funafuti, but the dead coralla of apparently four distinct species were picked up on the outer beaches of the islands, showing that the genus must live in considerable abundance close outside the reef. These specimens are, unfortunately, too much worn to be identified with any certainty, but may be provisionally referred to *F. crassa*, *F. patella*, *F. discus*, and *F. tenuifolia*.

1. FUNGIA PATELLA Ellis and Solander.

Madrepora patella, Ellis and Solander, Zooph. p. 148 (1786).

Fungia patella, Edwards and Haime, Cor. iii. p. 7.

Fungia patella, Klunzinger, Die Korallthiere des Rothen Meeres, Th. iii. p. 61.

I have referred three specimens to this species, which were obtained all together in a small pool a few feet across. Among themselves they vary considerably in the perforations of their under surfaces and the thickness and spinulation of their septa. In shape they are more or less round, 11–13 cm. in diameter, with rather open, oval fossæ in the centre.

Wakaya, Fiji; fringing reef.

I have also ascribed to the same species as the above a stunted anthocyathus, which was found in the same pool, about 9 cm. in diameter, with a part of the upper surface killed by an incrusting nullipore. The septa are much thicker than in the preceding specimens and have deeper and more regular dentations, while the under surface is almost imperforate.

In the same pool were obtained 24 trophozooids and anthoblasts, forming a good series to the free anthocyathus. The youngest of these has 24 septa, of which 12 are much the larger and thicker, and are joined by a few synapticala.

2. FUNGIA DENTATA Dana.

Fungia dentata, Dana, Zooph. p. 293, pl. xviii. fig. 7.

Fungia dentata, Edwards and Haime, Cor. iii. p. 10.

A single specimen closely corresponding to the descriptions. The fourth, fifth, and sixth cycles of septa in one part of the corallum, where the edge of the calice has grown somewhat upwards, are characterized by a large, pointed, raised tooth at the inner edge with a deep bay outside. In other parts, where the upper surface of the disc is convex, the tooth is usually present, but less distinct and with no deep bay.

Rotuma; boat-channel.

3. *FUNGIA CRASSITENTACULATA* Quoy and Gaimard.

Fungia crassitentaculata, Quoy and Gaimard, Voy. de l'Astrol., Zool. t. iv. p. 182.

Fungia crassitentaculata, Edwards and Haime, Cor. iii. p. 19.

I have with some hesitation referred one specimen, 13 cm. in diameter, to this species as it corresponds fairly well with the descriptions and two named specimens—one in spirit—in the British Museum.

Rotuma; boat-channel.

4. *FUNGIA DENTIGERA* Leuckart.

Fungia dentigera, Leuckart, De Zooph. Corall. p. 48, tab. iii. figs. 1, 2.

Fungia dentigera, Dana, Zooph. p. 301, pl. xviii. fig. 4.

Fungia dentigera, Edwards and Haime, Cor. iii. p. 17.

There is one specimen of this species, 13 cm. long by 7 cm. broad, which closely corresponds to Dana's figure and description. The margin, too, has the same obsolescent folds.

Rotuma; boat-channel.

5. *FUNGIA DANÆ* Edwards and Haime.

Fungia echinata, Dana, Zooph. p. 294, pl. xviii. figs. 8, 9.

Fungia danæ, Edwards and Haime, Ann. des Sci. Nat. t. xv. p. 80 (1851).

Fungia danai, Edwards and Haime, Cor. iii. p. 11.

There is one specimen of this species, about 12 cm. in diameter, which seems to be to some extent intermediate between Dana's Fijian and East-Indian specimens. The large radiating lamellæ of the under surface are at the edge of the corallum about 1.2 cm. apart and correspond to the first four cycles of septa; in places the lamellæ of the fifth cycle are nearly as large, while those of the sixth to the eighth can usually be distinguished running inwards for 1-2 cm. On the upper surface the septa are less strongly and more regularly toothed than in either of Dana's specimens. At the inner ends of those septa, which do not reach the axial fossa, there is generally a low but distinct tooth, about 3 mm. broad.

Rotuma; boat-channel.

Genus *HALOMITRA*.

Halomitra, Dana, Zooph. p. 311 (1846).

Halomitra, Duncan, Journ. Linn. Soc., Zool. xviii. p. 144.

Halomitra, and *Podabacia* Quelch, Challenger Reef-Corals, pp. 138-141.

The characters by which Quelch separated *Podabacia* and *Halomitra* are, I consider, mainly due to the age and mode of growth of the specimens which he examined and of those which had been previously described.

The free corallum seems from my specimens (2) to have been formed in a somewhat similar manner to that of the genus *Fungia*, by the breaking off of discs from an attached stock. At first there

is one large central polyp with radiating septa; then, as growth proceeds, a number of calicular fossæ appear around this. On becoming free, the central polyp may perhaps persist, or, as in my specimens, may become indistinguishable from the daughter polyps, the septa gradually losing their regular radiating arrangement in the centre of the colony.

1. *HALOMITRA IRREGULARIS*, n. sp. (Plate XLIII. figs. 1, 2.)

Corallum subcircular or somewhat irregular, slightly convex above and concave below, heavy and thick. Under surface dense and little perforated, with no distinct costæ, but closely covered by low, blunt, extremely granulated papillæ, in places forming low clusters. Calicular fossæ in the young colony arranged round a large deep central fossa, but in the older colonies equal in size and irregularly arranged in the central parts, only radiating near the edges of the corallum. Calicular fossæ generally somewhat oval in shape and in the centre 6–12 mm. distant from one another. Septa very distinctly radiate on the outer parts of the corallum, but towards the centre of the colony 6–12 large, thick septa can be distinguished radiating in all directions from the calicular fossæ, with a like number of low, thin septa between; these are continuous between the different fossæ, but the radiating arrangement of the septa of the colony in the centre is very imperfect. The large septa are relatively thick with granular sides; their free edges are very evenly covered by blunt denticulations, 1–1.5 mm. high and 12–14 in 1 cm. The axial fossæ are deep and have no columellæ.

Funafuti; lagoon shoals to leeward.

Of the two specimens in the collection the smaller is a nearly round disc about 12 cm. in diameter by 4.5 cm. high. The under surface is very slightly concave with an oval-shaped area in the centre, surrounded by a groove where apparently the disc was broken off from its nurse stock.

The larger specimen is 18 cm. long by 13 cm. broad and 7 cm. high, oval in shape with the edges irregularly bent. The under surface is slightly concave with several deep grooves, from which two nurse stocks grow outwards. The smaller of these is about 1.5 cm. high, with the calice about 8 mm. broad and somewhat turned upwards and inwards, so that its inner half is incomplete, while in the outer half primary, secondary, and tertiary septa can be distinguished. The larger nurse stock is about 3 cm. high by 4 cm. broad at the top and 2 cm. at its lower end, where it is rather constricted. It consists of a single large calicle with a central axial fossa, 1.5 cm. deep. From this 5 cycles of septa can be distinguished radiating to the circumference. These are broken, however, in 6 or 7 places where daughter calicular fossæ are being formed, the corallum underneath the new polyp mouth being absorbed or ceasing to be formed, so that a fossa results.

Generally on the upper surface of the corallum the large septa are very regular in appearance, bending inwards towards the ends of the daughter fossæ. Near the edges of the colony the

end septa of the calicles are often formed by mere thickenings, standing out at right angles on the radiating septa of the original central calicle.

Genus HERPOLITHA.

Herpolitha, Eschscholtz, Isis, p. 746 (1825).

Herpetolitha, Edwards and Haime, Cor. iii. p. 23.

Herpolitha, Duncan, Journ. Linn. Soc., Zool. xviii. p. 145.

A good description of the corallum of this genus has been given by Duncan¹. A comparison with that of *Polyphyllia* will probably cause the absorption of that genus, as the smaller specimens of both genera are extremely alike.

1. HERPOLITHA CRASSA Dana.

Herpolitha crassa, Dana, Zooph. p. 310, pl. xx. figs. 5-5 c.

Two specimens of this species were obtained, which closely resemble the description and figures given by Dana. The smaller is regular in shape, 16 cm. long by 6 cm. broad, 4.5 cm. high, concavity of the under surface 1.7 cm. deep. The larger specimen has the edges, especially at the ends of the corallum, very irregular and much bent; the calices, too, are less regular on each side of the central row. The colony is 21 cm. long by 11 cm. broad, 7.2 cm. high, concavity of the under surface 4 cm. deep.

The colour of the living colony was light brown, with dark bands around the mouths of the polyps.

Funafuti; lagoon shoals.

Genus PAVONIA.

Pavonia, Lamarck, Syst. des Anim. sans Vert. p. 372 (1801).

Pavonia, Lamarck, Hist. des Anim. sans Vert. t. ii. p. 238 (1816).

Lophoseris, Edwards and Haime, Cor. iii. p. 65.

Lophoseris, Duncan, Journ. Linn. Soc., Zool. xviii. p. 157.

I have retained the name *Pavonia* for this genus, as it has clearly the priority over Hübner's use of the term for a genus of Lepidoptera.

The genus is represented in the collection by 19 specimens, of which 17 have been referred to 4 well-known species. The other two, which I have described as new under the names of *P. intermedia* and *P. calicifera*, are intermediate between *P. repens* and *Tichoseris obtusata* in some of those characters by which Quelch diagnosed the genus *Tichoseris*². In *P. intermedia* the character of the valleys and ridges approaches *P. repens*, while *P. calicifera* has almost completely circumscribed calices, *Tichoseris obtusata* coming between the two with "sinuous groups of two or more centres." The same method of increase is found in all 3 species, by fissiparity and also by gemmation, the calices

¹ Journ. Linn. Soc., Zool. xvii. pp. 152-155 (1884).

² Ann. & Mag. Nat. Hist. vol. xiii. 1884, p. 295.

being separated by the upgrowth of a wall between the septa connecting the axial fossæ. The septa are not confluent in *Tichoseris*, but lie opposite to one another, while in *P. intermedia* over the highest ridges and in *P. calicifera* generally they are almost completely separated, being joined over the walls only by their small spines. The columella in *P. intermedia* is visible from the surface as a small spine; in *P. calicifera* it is very deep, with usually no spine; and in *Tichoseris* it is very rudimentary. In all it appears to be a true columella and is joined by trabeculæ to the septal edges. The synapticula gradually decrease in size from *P. repens*, in which they are very abundant; in *Tichoseris* they are "distant, being generally rather thick interseptal outgrowths of the upper part of the wall,"—almost precisely the same condition as in *P. calicifera*, where they are only found near the wall. The septa, further, in all the species are almost precisely similar in their arrangement and spines.

For the above reasons I consider that the genus *Tichoseris* must be absorbed in the genus *Pavonia*.

1. PAVONIA DIVARICATA Lamarck.

Pavonia divaricata, Lamarck, Hist. des Anim. sans Vert. t. ii. p. 240 (1816).

Pavonia divaricata, Dana, Zooph. p. 327, pl. xxii. fig. 6.

Three specimens, apparently from the same clump at Rotuma, and some fragments have been referred to this species, from which *P. minor*, Brüggemann, does not seem to be distinct.

Rotuma; deep pool in outer reef by Solkopi. Wakaya, Fiji; lagoon reef.

2. PAVONIA CRISTATA Ellis and Solander.

Madrepora cristata, Ellis and Solander, Zooph. p. 158, tab. xxxi. figs. 3, 4 (1786).

Madrepora boletiformis, Esper, Pflanz., Forts. Th. i. p. 61, tab. lvi. (1797).

Pavonia decussata, Dana, Zooph. p. 329, pl. xxii. fig. 4.

Lophoseris cristata, Edwards and Haime, Cor. iii. p. 66.

I have referred a number of fronds to this species, some of which closely resemble Dana's figure of *P. decussata*, while others approximate more to Esper's figure of *M. boletiformis*, and others, again, are much more subdivided at their free edges and crispate.

The septa in the different specimens vary greatly in thickness, but large and small always alternate. In the more crispate fronds the large septa are very thin with almost smooth sides, and the small septa are often indistinguishable, while in the flatter fronds the former are thick with rough sides and the latter are quite distinct. If the septa, however, in a camera lucida drawing of a few calices of a crispate frond are thickened, as would naturally occur with increased age, the arrangement in both forms is seen to be precisely similar. In some fronds the calices

tend to be somewhat circumscribed, but generally they lie in rows nearly parallel to the free edges.

The vertical keels mentioned by Edwards and Haime are not, I think, of any specific importance; one of the fronds shows their formation by the fusion of the edges of two of the crisped ends, the septa later, as growth proceeds, becoming secondarily continuous over them.

Rotuma; deep pool in outer reef by Solkopi.

3. PAVONIA FRONDIFERA Lamarck.

Pavonia frondifera, Lamarck, Hist. des Anim. sans Vert. t. ii. p. 241 (1816).

Pavonia frondifera, Dana, Zooph. p. 328.

There are two fronds which closely correspond to the descriptions of this species, but which may perhaps belong to the last. The synapticular separations of the calices are not so broad as in *P. cristata*, and the fronds are much thinner and more delicate.

Wakaya, Fiji; outer reef.

4. PAVONIA REPENS Brüggemann. (Plate XLIV. fig. 2.)

Pavonia repens, Brüggemann, Abh. nat. Ver. zu Bremen, Bd. v. p. 395, Taf. vii. fig. 1 (1878).

Pavonia repens, Klunzinger, Die Korall. des Roth. Meeres, p. 75, Taf. ix. fig. 3.

There are four specimens of this species, which is well marked by its long valleys, meandering over the whole of the colony. The walls are very much thickened below, making the whole corallum very dense and almost obliterating the cavities of the calices. The corallum is in places 2-3 cm. thick.

Funafuti; outer reef (fairly common to leeward) and lagoon shoals.

5. PAVONIA INTERMEDIA, n. sp. (Plate XLIV. fig. 3.)

Corallum primarily incrusting, then massive with the upper surface very irregular, often raised up into knobs and hillocks; edge sometimes free for a few mm. and covered apparently by an epitheca.

The axial fossæ are usually deep and surrounded by very steep radiating septa, leading up to the summits of the walls. Budding takes place anywhere over the septa, fission rarely occurring. Commonly about 4 low septa extend from the new axial fossa to the old calicular fossa. Soon, however, these grow up to the height of the calicular wall, and an imperforate wall is built up between them, completely separating the new calice except over its summit. Before the latter occurs, other buds are generally formed from the parent polyp, so that often 3 to 6 distinct fossæ are found in the same valley, which, however, is always bounded on all sides by a wall, thin at the surface but much thicker below, so that the corallum is very dense and heavy.

In the smallest circumscribed calices 12 or 14 septa can be

distinguished, of which about half extend to the axial fossæ. In the larger there are from 20 to 30, alternately thick and thin, the former projecting to the fossæ and the latter about half as far. In the still larger calices, which are about to bud, there are often 40 to 60 septa, the increase being due to the appearance of a fresh cycle.

The septa are continuous over all except the highest ridges, where they lie opposite to one another. All are rough and very irregularly granulated both at the edges and sides. The synapticula are numerous, small, and thin, being especially abundant near the wall, into which, as it thickens, they are mostly absorbed. There is apparently a true columella arising deep down in the calice, joined to the septal edges by trabeculæ and from the surface generally visible as a small compressed spine.

Depth of the calices from the top of the ridges to the columella about 3 mm.; breadth from ridge to ridge about the same. Valleys seldom more than 1 cm. long, with 40-60 septa on their edges in 1 cm.

Rotuma; outer reef.

The specimen on which this species is founded is a small incrusting mass 9 cm. in greatest width by in one place 4 cm. in height. Its base is much bored into by Chætopoda, Sipunculoidea, and other organisms. In one place, where a nodule has grown out at the edge, the under surface is covered by very shallow calices, with a limited number of septa, alternately thick and thin, and continuous between the fossæ, the appearance more approximating to that of the branching species of the genus.

6. PAVONIA CALICIFERA, n. sp. (Plate XLIV. fig. 4.)

Corallum dense and heavy, incrusting and massive, often with the edges free for a few mm.

Surface covered by usually completely circumscribed calices, separated by thin imperforate walls. Increase both by fissiparity and gemmation, the latter from any part of the polyp, but generally close to the wall, where several calices meet. The septa are at first continuous between the axial fossæ; but the wall quickly grows up between them, so that the new calice soon becomes completely circumscribed and valleys do not result. The calicular wall is thin at the surface, but thickens below, fusing with the outermost synapticula. The latter are not numerous, being found only near the opening of the calice.

The septa are continuous by their spines over the wall from calice to calice; all are thin, rough, and granulated irregularly, both at their sides and edges, and project inwards with at first a gradual slope, ending perpendicularly by the fossæ. In the smallest calices primary, secondary, and tertiary septa can be distinguished, the former projecting to the axial fossa and being joined to the columella by trabeculæ. In the larger calices a few of the secondary septa have become fused to the columella, and two additional cycles can usually be distinguished. The columella

lies deep down in the axial fossa, closing it below and not projecting appreciably above its first junctions with the septa.

Depth of the calices to the top of the columella varying up to 4 mm. ; breadth about the same.

Rotuma ; outer reef.

This species is to be distinguished from *P. intermedia* by the far more completely circumscribed calices. The wall, too, is thinner and no ridges between valleys are found. The fossæ have a far less open appearance, the septa in *P. intermedia* sloping inwards from the wall, more precipitously at first.

Genus PSAMMOCORA.

Psammocora, Dana, Zooph. p. 344 (1846).

Coscinarcea, Edwards and Haime, Compt. Rend. t. xxvii. p. 496 (1848).

Mæandroseris, Rousseau, Voy. au Pôle Sud de D'Urville, Zool. t. v. p. 121 (1854).

Plesioseris, Duncan, Journ. Linn. Soc., Zool. xvii. p. 309 (1884).

The genus *Psammocora* was placed by Dana among the Fungida, and diagnosed as follows:—"Attached Fungidæ, glomerate or ramose ; tentacles of polyps obsolete, polyps not seriate ; interstices sometimes flat, usually throughout turgidly elevate, the surface, then, consisting of excavate cells. Coralla porous ; orizimes minute ; lamellæ very minute, often indistinct, and very minutely arenoso-denticulate, often irregular, not alternately smaller."

The genus is represented by four named species in my collection, of which I have examined *P. obtusangula* and *P. haimiana* as types respectively of the ramose and massive forms. In the former the calices are superficial, the surface has generally a rather sandy appearance, and the septa are thick and few in number (very commonly 8). In *P. haimiana* the calices are very deeply excavate, with an appearance of distinct walls at the surface, and the septa are thin and numerous (seldom less than 16).

Fractures, made longitudinally and transversely, show that the septa in *P. obtusangula* are at first continuous between neighbouring axial fossæ. They are usually studded at the free surface with a few rather wide, blunt spines, which are commonly rather broader than the parts of the septa between. The septa under these spines are thick and very solid, while the parts between are thin and sparsely perforated ; the septa thus, in section, have a ridged appearance. The ridges on neighbouring septa lie opposite to one another, and in places are thickened and meet, forming synapticula, which are accordingly arranged in vertical series. In the middle of the septa, extending from fossa to fossa, the synapticula are especially large and closely arranged, forming a much perforated wall, which becomes thicker and more solid below, partially, apparently, owing to trabeculæ arising from the sides of the septa. Commonly, on either side of this central row, another line of synapticula is well marked. In the centre of the axial fossa is a small blunt spine, which does not appear to be a

true columella, but to be formed on the top of fused trabeculæ from the septal edges.

In *P. haimiana* (Pl. XLV. fig. 1) the septa are evenly covered on the upper surface with blunt, subequal spines, which are much more numerous than in *P. obtusangula*, but have given rise to the same ridging of the septa, although less markedly. Intermediate to the axial fossæ the synapticula form a very thick vertical row between the several septa, reaching right up to their edges below the spines and simulating a wall. Commonly, close to this, on either side, is another row of large synapticula. Deeper in the colony these rows fuse, owing apparently to the thickening of the corallum between and the formation of trabeculæ from the sides of the septa, a single, thick, slightly perforated wall resulting. Synapticula are found also between the septa within this false wall; they are much thinner and less elongated than those which form the wall, but placed in the same way in vertical series between opposing thickenings of the septa. The axial fossa is closed below by trabeculæ from the septal edges; commonly a central spine can be distinguished, surrounded by a circle of spines, corresponding more or less in number with the septa.

I have also ascribed to the genus *Psammodora* three new species, which I propose to call *P. profundacella*, *P. superficialis*, and *P. savigniensis*, which agree with it in the general characters of their septa, the arrangement of the synapticula, and the formation of a false columella by the fusion of trabeculæ from the septal edges.

P. superficialis (Pl. XLV. fig. 2) resembles *Meandroseris bottæ*, Rousseau, and differs from *P. haimiana*, in that its calices are not nearly so completely circumscribed, and are arranged more or less in series; the septa, too, are more regularly ridged, more perforate, and usually continuous between the calicular fossæ. There is, as in *P. haimiana*, between neighbouring fossæ a distinct central row of synapticula, which, however, do not rise so high as to give from surface-view the appearance of a wall. The rows on either side are well marked, but are not generally visible from the surface; deeper in the corallum, however, they are fused with the central row, and form a wall precisely similar to that of *P. haimiana*. The axial fossa is closed in below, both in *Meandroseris bottæ*, as described by Duncan¹, and in *P. superficialis* as in *P. haimiana*, by trabeculæ from the septal edges.

P. profundacella (Pl. XLV. fig. 3) very closely resembles *Plesioseris australiæ*, Rousseau, indeed only differing from it, so far as the description goes, in having its calices rather deeper, with a considerably larger number of septa and less regularly arranged in series. *Plesioseris australiæ* has, however, according to Duncan², a true wall. In *P. profundacella*, as also in a specimen named *Plesioseris*, apparently by Duncan, in the British Museum, there is no true wall, but between the fossæ a row of synapticula, very

¹ Journ. Linn. Soc., Zool. xvii. p. 308.

² Loc. cit. p. 309.

elongated vertically and close set, which rises almost to the surface of the corallum as in *P. haimiana*. There is also a row on either side, distinct near the surface, but much thickened below, forming with the central row a broad wall. Additional rows, still deeper, have likewise thickened, so that the corallum appears in section to be extremely dense.

I have compared *P. savigniensis* (Pl. XLV. fig. 4) with a specimen of *Coscinaræa monile*, Forsk. (syn. *C. mæandrina* Ehr.) in the British Museum. The superficial resemblances between the two species are very great, *P. savigniensis* differing mainly in the size of its calices. The basal wall differs, however, from that of the specimen described by Duncan¹ in being without costæ, and is, I consider, an epitheca. From the surface no central row of synapticula can be distinguished between the fossæ in either *P. savigniensis* or *Coscinaræa monile*, but fractured and ground surfaces of the former show that there is a distinct central row with a well-marked row on either side. The synapticula are not so thick or so close set as in *P. haimiana*, and, further, scarcely thicken at all deep down in the corallum, so that the spaces between the rows are little obliterated, in this resembling *P. obtusangula*. The septa, too, in *P. savigniensis* are very distinctly ridged, and much perforated in the valleys, as in *Mæandroseris bottæ*, while the axial fossæ are closed below in precisely the same way as in *P. haimiana*.

The genus *Plesioseris* was separated by Duncan² from *Mæandroseris* on the ground that its calices have a distinct wall and very slightly trabeculate and imperforate septa. The examination of the gemmation in *P. profundacella* and *P. superficialis* has shown me that budding usually takes place by the body-wall of the polyp, somewhere over the septa, forming a new calicular centre. The septa, then, between the new and the old fossæ are built up and joined at the same time by synapticula, so that finally a distinct though slightly perforated wall is formed; ridges result by the budding again and again of the mother-polyp before the wall has had time to grow up. In *P. superficialis* are a number of such ridges, but the calicular centres are not arranged in any determinate order in respect to them, while in *P. profundacella* the calices are single or in short series, completely separated by such ridges.

From a consideration, then, of the resemblances of the above species I propose to absorb the genera *Mæandroseris*, *Plesioseris*, and *Coscinaræa* into the genus *Psammocora*, Dana.

The diagnosis of *Psammocora* in accordance with the hard parts would be as follows:—Colonial Fungida primarily incrusting, but later massive or foliaceous. An epitheca is present as an imperforate basal wall, but there is no true theca. Calicular fossæ distinct, closed in below by trabeculæ arising from the septal edges. Synapticula numerous and stout, in vertical series, often appearing to form a wall between the calicular fossæ. Septa

¹ *Loc. cit.* p. 314.

² *Loc. cit.* p. 309.

generally thick, and often much fused together, bluntly and evenly spinulose at the free edges, more or less vertically ridged and perforate. Gemmation anywhere over the septa.

The species in the genus naturally fall into two divisions, branching and massive. The former generally have very superficial calices; septa few, with a small number of large spines on the free edges; synapticula broad and reaching almost to the surface, giving a rather sandy appearance to the corallum. The massive forms have deeper calices separated by collines; numerous septa with a large number of small spines on the free edges.

I. *Branching forms.*

1. PSAMMOCORA OBTUSANGULA Lamarck.

Pavonia obtusangula, Lamarck, Hist. des Anim. sans Vert. t. ii. p. 240 (1816).

Psammocora obtusangula, Dana, Zooph. p. 345.

Psammocora obtusangula, Edwards and Haime, Cor. iii. p. 220, pl. E 3. fig. 3.

There is one small dried specimen besides numerous spirit-specimens of this species, which closely resemble Milne-Edwards's description and figure (3*b*). In many of the calices there are only eight septa, in some four thick and four thin, the latter projecting furthest into the calices. Colour of the living colony green.

Rotuma.

2. PSAMMOCORA CONTIGUA Esper.

Madrepora contigua, Esper, Die Pflanz., Forts. Th. i. p. 81, tab. xlvi. (1797).

Psammocora plicata, Dana, Zooph. p. 346, pl. xxv. fig. 2.

Psammocora contigua, Edwards and Haime, Cor. iii. p. 220.

There are two specimens of this species, which very closely resemble Dana's figures and description. The colour of the living colony was a light olive-brown.

Funafuti; lagoon reef.

3. PSAMMOCORA GONAGRA Klunzinger.

Psammocora gonagra, Klunzinger, Die Korall. des Roth. Meeres, p. 81, Taf. ix. fig. 1.

I have referred three fragments to this species, which seem to differ from *P. obtusangula* mainly in their less distinct calices, more abundant synapticula and trabeculæ, and thinner septa.

Wakaya, Fiji; outer reef.

II. *Massive forms.*

4. PSAMMOCORA HAIMIANA Edwards and Haime. (Plate XLV. fig. 1.)

Psammocora haimiana, Edwards and Haime, Monogr. des Poritides, p. 68, and Cor. iii. p. 221.

Psammocora haimiana, Klunzinger, Die Korall. des Roth. Meeres, p. 81, Taf. ix. fig. 5.

The structure of the corallum has been described above, with the genus, as a type of the massive species.

Funafuti; lagoon. Three small specimens.

5. *PSAMMOCORA SUPERFICIALIS*, n. sp. (Plate XLV. fig. 2.)

Corallum primarily incrusting, with a thin margin seldom free, then becoming massive, with a tendency to round itself off and fall over by the wearing away of its base.

The surface is covered with irregularly arranged calices, and has a number of scattered ridges. Gemmation takes place anywhere over the septa, but especially at the angles where three or more calices meet. The ridges appear to have been originally collines separating rows of calices, but by irregular budding to have been broken up, so that in the older parts they appear to bear no relationship to the calices.

The calices are 1.5–2.5 mm. in diameter. Owing to the method of gemmation their septa vary greatly, but usually about ten end freely by the axial fossæ, while about the same number are fused towards the exterior with these. The fusion, however, is not regularly in pairs, some of the septa always running to the exterior of the calice; for instance, the nine freely-ending septa of one calice were made up by 5, 1, 5, 1, 3, 1, 4, 1, and 2 septa respectively. The septa are thick, being commonly broader than their interseptal spaces; their upper edges are covered with low, subequal spines, themselves both at the tops and sides minutely spinulose.

There is no true theca between the calices. When a fresh calice is budded off, the septa connecting its fossa to the old calicular fossa grow upwards and become closely connected by synapticula and trabeculæ, so that the ridges often seem to have much perforated walls, over which the septa are not continuous.

The axial fossa is filled up by trabeculæ from the septal edges, which commonly bear a central spine, surrounded by a circle of slightly smaller spines, generally lying opposite to the larger septa.

Funafuti; lagoon shoal.

6. *PSAMMOCORA PROFUNDACELLA*, n. sp. (Plate XLV. fig. 3.)

Corallum primarily incrusting, but later forming low masses, which may break off at the base.

The surface is covered by irregularly-shaped calices, either completely circumscribed or in short series with slightly projecting intermediate ridges; diameter of calices, or from ridge to ridge, 3–4 mm. Gemmation takes place by budding, either within the calice, when a short series results, or from the ridge, where three or more calices meet, when the young calice is from the first completely circumscribed. The valleys and the separate calices are usually 2–3 mm. in depth. A few of the septa of neighbouring

calices in the same valley are continuous between the fossæ, but not over the collines.

There is no true theca, but the calices are separated from one another, except those in the same valley, by a false wall formed by *synapticula* and *trabeculæ*.

The septa arise at first almost perpendicularly from the fossa, but towards the exterior of the calice extend more gradually outwards, generally having one very distinct row of *synapticula* at a short distance within the false wall. They vary greatly in number, but commonly at least thirty can be counted near the edge of the calice, some running singly to the axial fossa, but the majority fusing up irregularly, only about twelve ending freely. Their upper edges are covered with very small, blunt, subequal spines, themselves minutely spinulose at the sides and summit.

The axial fossa is closed in below by *trabeculæ*, which often above are prolonged into a few blunt spines, which may simulate a *columella*.

Funafuti; lagoon shoals.

7. *PSAMMOCORA SAVIGNIENSIS*, n. sp. (Plate XLV. fig. 4.)

Corallum at first incrusting, but later forming low, convex masses, which often die in the centre but continue to grow at the periphery. The margin may be free for a few mm., when the base is seen to be formed by a thin, solid, imperforate wall, probably an *epitheca*.

The surface is marked by very irregularly-shaped calices, which either lie quite separately, or in short series with 2-7 distinct centres. Increase is by gemmation over the *septo-costæ* at the margin, or anywhere within the calice. The axial fossæ in separate valleys are usually from 3.5-5 mm. apart, in the same valley rather less. In depth the calices vary up to about 3.5 mm.

The septa vary greatly in number, but usually towards the exterior of the calice about 36 can be counted, of which perhaps half reach the axial fossa, the remainder coalescing with them and seldom ending freely; no arrangement of cycles can be distinguished. In the deeper calices they are quite thin, but in the serial calices generally wider than the interseptal loculi. Their free edges are covered with low, rough, subequal, blunt spines, which are often somewhat flattened on the thicker septa at right angles to their plane. The collines are rounded, 1-1.5 mm. in breadth, the lower covered with spines, which are directly continuous between the septa of neighbouring calices, but the higher somewhat *trabecular* in appearance and irregularly spined.

In section the septa can be seen to be much perforated, especially near the axial fossæ, and appear to be directly continuous between neighbouring calices. There is no true theca, but between the deepest calices a thin, much perforated wall has been formed by the fusion of *synapticula* and *trabeculæ* from the septa; a well-marked row of *synapticula* on either side in addition is a common feature, but it is never fused with the central row.



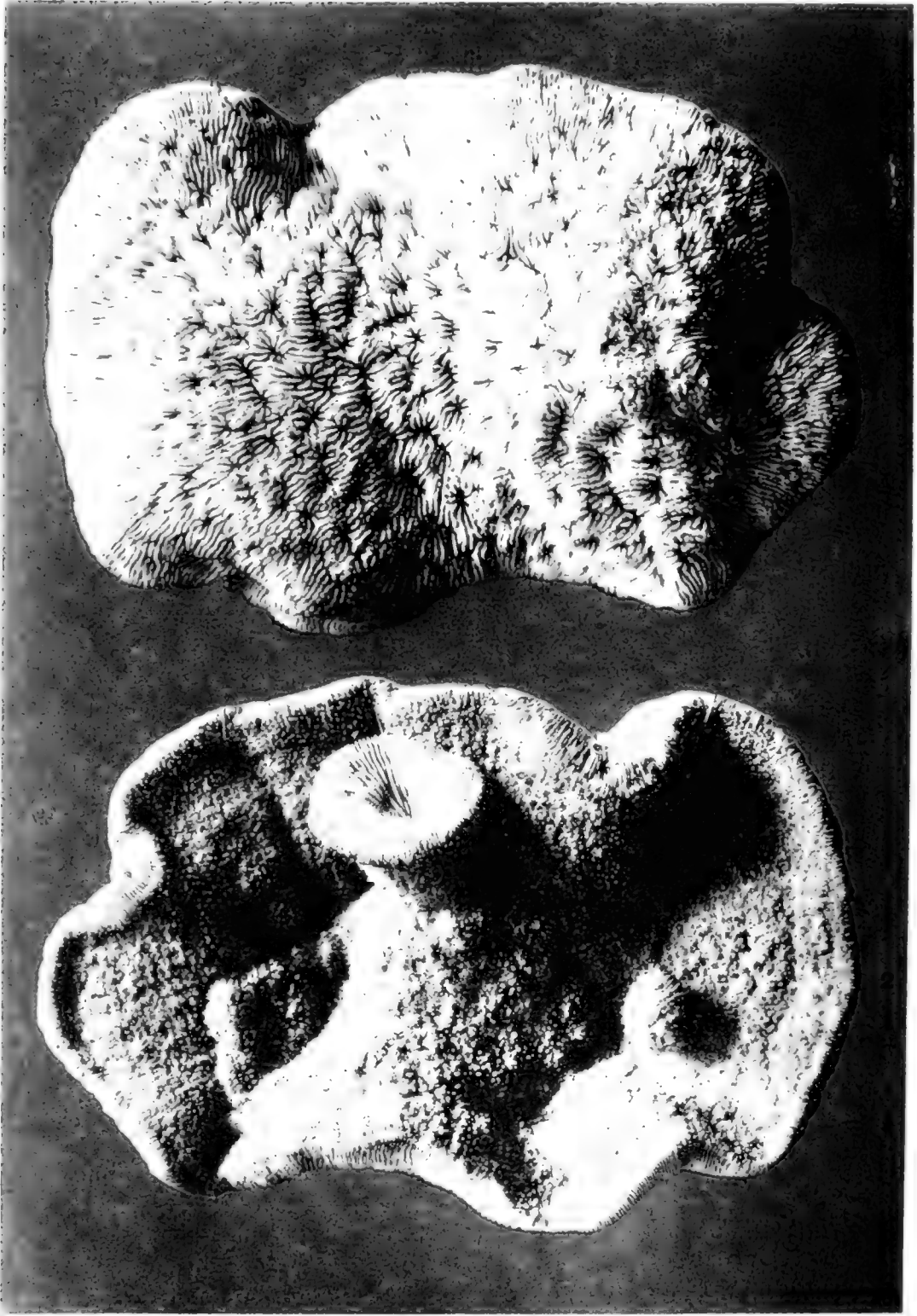

Photograph by Bale & Banerleeson Ltd

2. FALS FROM THE SOUTH PACIFIC



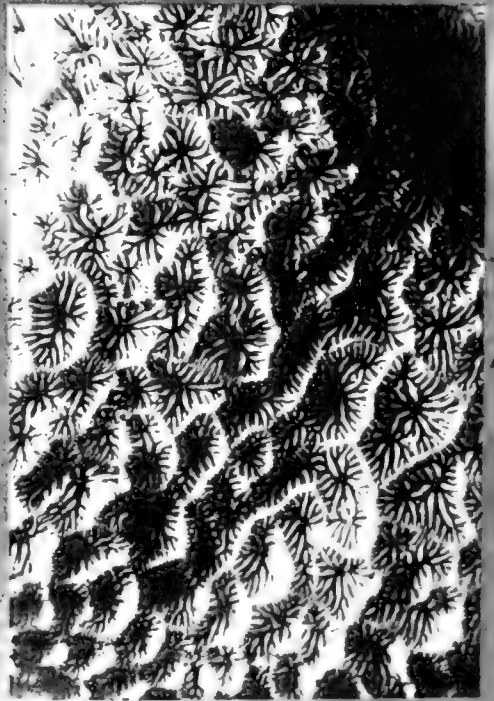
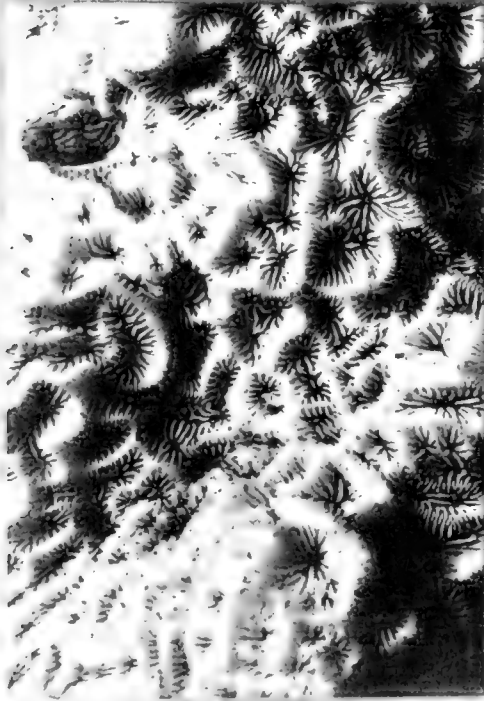
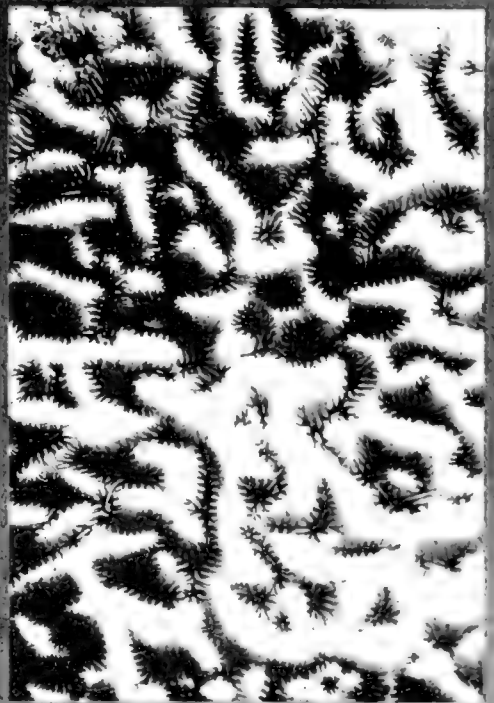
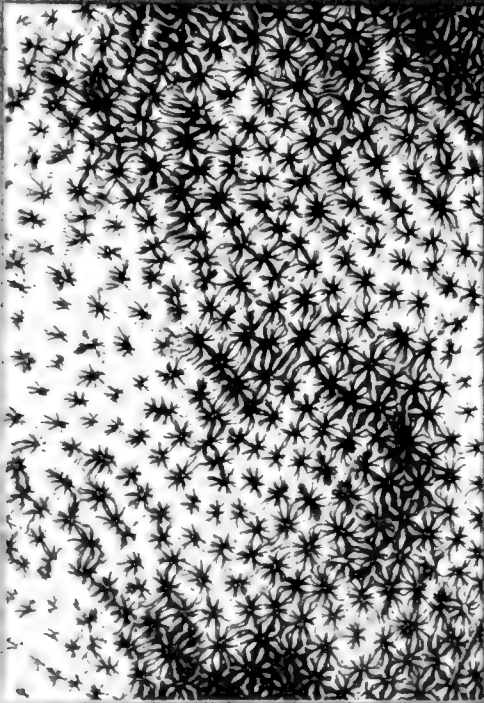



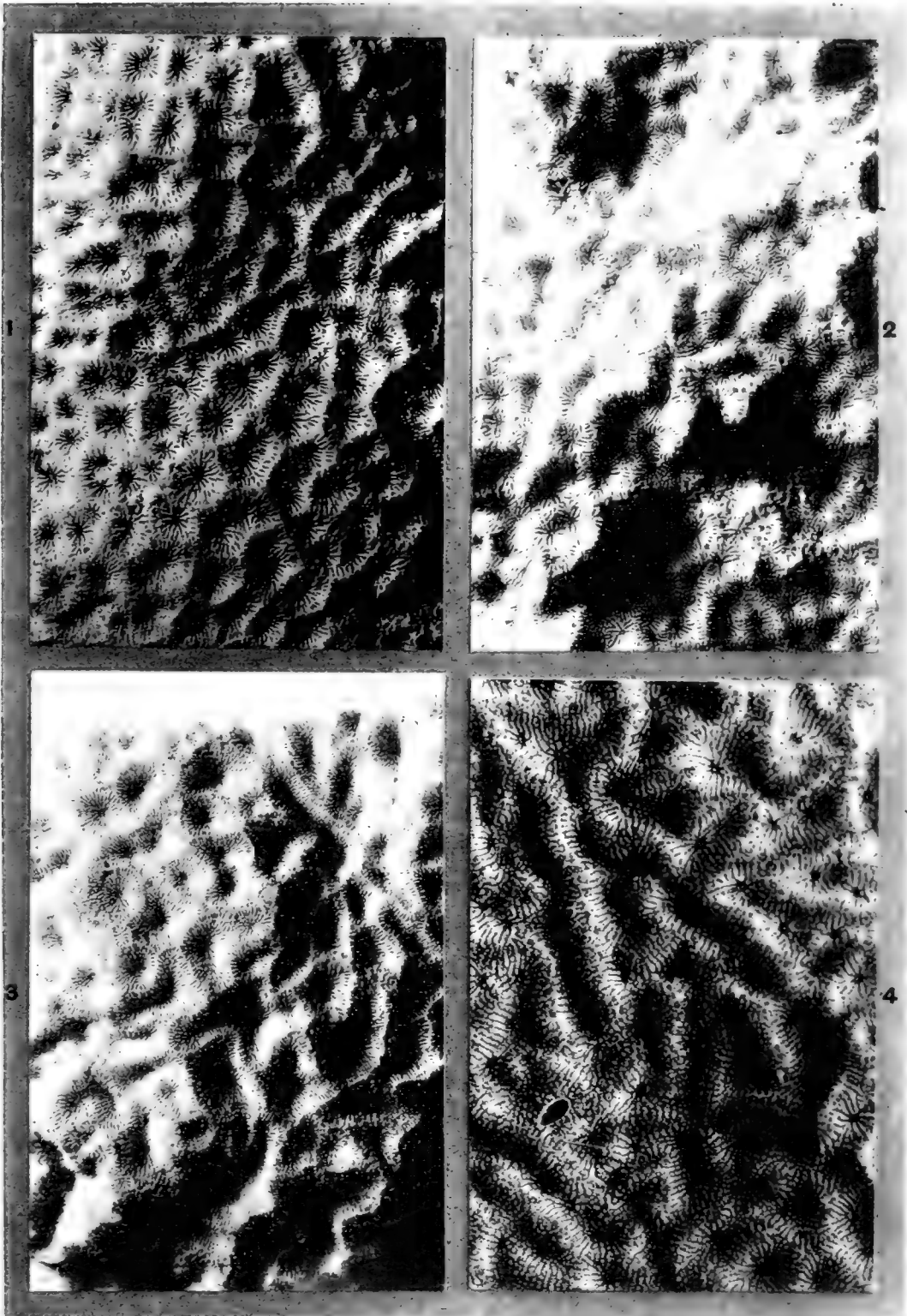

Photoprint by Bale & Lanielsson Ltd

CORALS FROM THE SOUTH PACIFIC

Funafuti and Rotuma; outer reefs.

There are two specimens of this species, pieces of much larger masses, the greater part of which has been killed by green algal and nullipore growths. The Funafuti specimen seems to be the edge of a large mass which has died in the centre; its calices are generally in short series with low collines. The Rotuman specimen, however, while possibly the edge of a similar mass, has its centres usually arranged separately, with high trabecular collines.

I propose to call this species after Savigny, who gave an excellent figure of *Psammocora monile*, to which it is very closely allied.

EXPLANATION OF THE PLATES.

PLATE XLIII.

- Fig. 1. *Halomitra irregularis*, upper surface, p. 528.
2. *Halomitra irregularis*, lower surface.

PLATE XLIV.

- Fig. 1. *Siderastræa clavus*, $\times 2\frac{1}{4}$, p. 525.
2. *Pavonia repens*, $\times 2\frac{1}{4}$, p. 531.
3. *Pavonia intermedia*, $\times 2\frac{1}{4}$, p. 531.
4. *Pavonia calicifera*, $\times 2\frac{1}{4}$, p. 532.

PLATE XLV.

- Fig. 1. *Psammocora haimiana*, $\times 2\frac{1}{4}$, p. 536.
2. *Psammocora superficialis*, $\times 2\frac{1}{4}$, p. 537.
3. *Psammocora profundacella*, $\times 2\frac{1}{4}$, p. 537.
4. *Psammocora savigniensis*, $\times 2\frac{1}{4}$, p. 538.

3. Description d'un Genre nouveau d'Ophidiens, *Geatractus*. Par ALFRED DUGÈS, M.D.¹

[Received June 6, 1898.]

J'ai décrit et figuré dans le Journal Mexicain 'La Natureza' (2^a serie, t. ii. 1897, pag. 455) un Ophidien nouveau sous le nom de *Geophis tecpanecus*.

Caractères généraux.—Aspect de Calamarien et de Coronellien. Noir à reflets bleus; dix barres blanches dorsales, courtes et transversales; un collier blanc passant sur la joue et la majeure partie de la gorge. Sept supralabiales, 3^{ème} et 4^{ème} touchant l'œil, la 5^{ème} la plus grande. Préoculaire unique, très petite, au dessus d'une freno-oculaire. Deux postoculaires. Temporales 1+2+2 (mal rendues sur la figure). Queue extrêmement courte, robuste et obtuse. Quinze rangs d'écaillés pourvues en général de deux pores apicaux. Une préanale. Tête 0.025 m., queue 0.023 m., longueur totale 0.50 m. Les vertèbres dorsales portent une hypapophyse très nette.

Mr. G. A. Boulenger a fait de ce serpent un *Atractus* (Zool. Rec. 1896, Rept. pag. 25), mais les *Atractus* n'ont pas d'hypa-

¹ Communicated by Mr. G. A. BOULENGER, F.Z.S.

pophyse aux vertèbres dorsales ni de fossettes apicales ; cependant le crâne de *G. tecpanecus*, dont j'ai figuré la seule partie que je possédais, ressemble plus à celui d'*Atractus* qu'à celui de *Geophis*. D'un autre côté les *Geophis* manquent de fossettes apicales et d'hypapophyses, quoique ils se rapprochent par leur ensemble du serpent en question ; de plus ils ont les dernières labiales supérieures en contact avec les pariétales, ce qui n'est pas le cas ici.

Il est donc évident que *G. tecpanecus* n'est ni un *Geophis* ni un *Atractus* ; mais comme il me paraît avoir des affinités avec les deux, je propose pour lui un genre nouveau, celui de *Geatractus*.

J'ai consulté à ce sujet une autorité en herpétologie, mon ami Mr. Boulenger, qui pense que ce genre est acceptable, et que c'est même un type fort intéressant, si peu de "Calamariens" étant pourvus de fossettes apicales.

4. Contributions to our Knowledge of the Plankton of the Faeroe Channel.—No. IV.¹ Report on the Copepoda collected by Dr. G. H. Fowler from H.M.S. 'Research' in the Faeroe Channel in 1896 and 1897. By ISAAC C. THOMPSON, F.L.S. (With an Appendix by Dr. FOWLER.)

[Received June 18, 1898.]

The material upon which this Report is based was collected in 34 out of the 41 hauls (omitting 12 *f*, the depth of which was not recorded). The Plankton had been immediately preserved in formalin, corrosive sublimate, or picric acid, and kept in 5% formalin. The Copepoda were picked out from the mass by Dr. Fowler, and sent to me in bottles labelled with the number of the station and letter of the haul whence the material was obtained.

By means of messengers in 1897 and of a screw-propeller in 1896 (see pp. 570-575), the mid-water tow-nets were opened and closed at will, enabling the depths to be almost accurately ascertained, the limit of error being dependent upon the possibly impeded rate of fall of the messenger or upon the accelerated rate of the screw-propeller in a very heavy sea.

The accompanying distribution table records the soundings, the depths at which the various hauls were taken, the temperature (Fahrenheit) at those depths, the number of meshes per inch of the net used, and the occurrences of each species. It will be seen that all the Copepoda collected are free swimmers, with one remarkable exception, that of *Argulus*, referred to later on.

The collection furnishes some interesting facts as to the influence of depth upon distribution. By far the commonest Copepod in the collection, and probably the most widely distributed species known, *Calanus finmarchicus*, occurs abundantly in 32 out of the 34 hauls,

¹ For Part I. see P. Z. S. 1896, p. 991 ; Part II., P. Z. S. 1897, p. 523 ; Part III., P. Z. S. 1897, p. 803.

and appears to be equally prevalent at all depths. But probably no other known species exhibits this ubiquitous feature to anything like the same extent. A reference to the distribution table will show that several species, such as *Heterochaeta abyssalis*, were not found at a less depth than 100 fathoms; while others, such as the well-known and beautifully coloured *Anomalocera patersoni*, usually remain about the surface, sometimes congregating in vast numbers.

The relative sizes of the same species at opposite depths is to a considerable extent seen in *Calanus finmarchicus*, the deep specimens being considerably larger than those found near the surface. Among our British Copepoda the largest known species is *Euchaeta norvegica*, but I am not aware that it has ever been taken in our waters at less than 80 or 100 fathoms, at which depth I have taken it in quantities in Loch Fyne, where it probably forms an important item in the diet of the herring.

The vertical distribution of Copepoda is doubtless to a considerable extent subject to climatic influences. During a continuance of stormy weather they often altogether desert the near surface and go very deep; while in fine warm weather many species love to gambol on the actual surface, presenting much the appearance of the "play" of the herring in miniature.

The size of mesh in the tow-net used is of considerable importance, and the apparent scarcity of such minute forms as *Oithona spinifrons* and *Ectinosoma atlanticum* is probably to be explained from the fact of a large mesh having been generally used; while the comparatively few tow-nets in which the above species were found were of a fine texture and probably might with advantage have been more generally employed.

Five out of seven species of Copepoda found by Dr. Brady in material from the Faeroe Channel (Exploration of the Faeroe Channel during the summer of 1880 in H.M.'s hired ship 'Knight Errant' by Staff-Commander Tizard, R.N., and John Murray) occur in this collection, viz.: *Eucalanus attenuatus*, *Centropages typicus*, *Anomalocera patersoni*, *Acartia longiremis*, and *Oithona spinifrons*.

The following species, viz., *Ætidius armatus*, *Euchirella pulchra*, *Heterochaeta abyssalis*, which occur sparingly in the collection, have never before been recorded north of the Mediterranean, this fact indicating a considerable extension of their distribution.

CALANUS HYPERBOREUS Krøyer.

A number of what I took to be specially large specimens of *Calanus finmarchicus* were found among the specimens from 20 *d.* Careful examination clearly proves them to be identical with *C. hyperboreus*, now recognized by Giesbrecht as a distinct species. The nipple-shaped lateral terminations of the cephalothorax, the large first abdominal segment, and the shape and position of the teeth on the basal joint of the 5th feet appear to be the chief points which separate *C. hyperboreus* from *C. finmarchicus*. Giesbrecht says that joint 19 of the anterior antennæ is as long as joints 23 and 24 together; but none of the very few specimens I found with

perfect antennæ agree with this description. Nor, curiously enough, does Giesbrecht's own exquisitely drawn figure (pl. vi. fig. 6, Pelagischen Copepoden des Golfes von Neapel &c.) bear it out.

Giesbrecht's grounds for making this a distinct species from *C. finmarchicus*, and not a mere variety, seem to me scarcely adequate. It is extremely likely that a species so widespread and living under so varied conditions should possess corresponding modifications such as we find here.

The very remarkable occurrence of three specimens of *Argulus foliaceus* in 15 *d* gathering is phenomenal; this species, so far as I am aware, having never been previously recorded except from fresh water, in which it is commonly found parasitic upon the stickleback, carp, and other fish. In this instance it appears to have been taken by the tow-net as a free-swimmer; and the only conclusion I can come to is that these three specimens became detached from a fish which had recently found its way into the sea from some stream. They in all particulars agree with *A. foliaceus*, differing markedly from any of the known marine species of *Argulus*.

[Notes to Table of Distribution.

- (1) Stations 11 to 19, 1896. Station 20, 1897.
- (2) The temperatures given for Station 20, hauls *a* to *d*, were not actually observed there, but are taken from the serial observations at Station 16; the difference between the two is probably trifling. The serial temperatures of the 1896 cruise are published in the Report of Proceedings &c. in the Faeroe Channel made by Capt. W. U. Moore, R.N., to the Hydrographic Office in 1896.
- (3) For the reason of the exclusion of *Calanus hyperboreus* from the table see p. 541.
- (4) VA=Very abundant. C=Common.
A=Abundant. F=Few.
S=Scarce.

G. H. F.]

Appendix to the foregoing Report. By G. HERBERT FOWLER, B.A., Ph.D., Assistant Professor of Zoology in University College, London.

Mr. Thompson's Report brings out some very interesting features, from the oceanographic standpoint, with regard to the distribution and bionomics of Copepoda. The most salient feature is, as he points out, the apparent indifference of *Calanus finmarchicus* to temperature and pressure. Like *Spadella (Krohnia) hamata*, discussed for the Faeroe Channel in an earlier paper of this series¹, and on a wider basis by Steinhaus² and Chun³, it is apparently equally happy whether at the surface under

¹ G. H. Fowler: Proc. Zool. Soc. 1896, p. 993.

² O. Steinhaus: Verbreitung der Chætognathen; Inaug. Dissert., Kiel, 1896.

8vo.

³ C. Chun: Beziehungen zwischen dem arktischen und antarktischen Plankton. Stuttgart, 1897.

pressure of 14 lbs., or at 500 fathoms under a pressure of half a ton, whether in bright light at a temperature of 54° F., or in utter darkness at a temperature of 30° – 32° F. Not only so, but it ranges apparently all over the globe (although not in such quantity¹ as in the Arctic Seas), except for the fact that it has not been recorded for the Equator and the hottest parts of the tropics, nor south of Cape Horn. In the Antarctic regions according to Chun² its place is apparently taken by *Calanus propinquus*; but Mr. Thompson informs me by letter, that in a recent examination of Antarctic Plankton he finds *Calanus finmarchicus* to be one of the commonest species. Its general distribution is cited by Giesbrecht³.

In discussing the Plankton of the Faeroe Channel it must be remembered that we are dealing with a 'Mischgebiet,' for which I would suggest the term 'Frontier,' a district in which the North-easterly continuation of the North Atlantic Drift (the so-called Gulf Stream), carrying a warm-water fauna, is constantly warring with a Southerly set of Arctic water carrying a cold-water fauna⁴. Both in 1896 and 1897 a succession of north winds had given a distinctly northern character to the fauna; and although, for example, *Ianthina*-shells and *Physophora hydrostatica* have in some cases been swept by the North Atlantic Drift as far north as the Lofoten Islands through the Faeroe Channel, I have not so far come across a single characteristically warm-water surface species in the 'Research' collections of either year from the Faeroe Channel.

Taking now the 34 hauls in which Copepoda were captured, we have 17 Epiplankton⁵ hauls of less than 100 fathoms, and 13 Mesoplankton⁵ hauls (including 12*a*, in which the depth was not so approximately known as in the other deep hauls, but which

¹ With the view of testing the Prince of Monaco's suggestion, that a tow-net could be made to provide food for shipwrecked boat's crews, we tried this species, raw, in the ward-room of the 'Research.' The Officers voted it excellent food, like "delicate shrimp-paste"!

² C. Chun, *op. cit.* p. 48.

³ W. Giesbrecht: Pelagische Copepoden des Golfes von Neapel, 1892, p. 89.

⁴ Compare Chun, Beziehungen zwischen d. arktischen u. antarktischen Plankton, pp. 7–10. Stuttgart, 1897. 8vo.

⁵ In my lectures on Oceanography at University College, I have felt the need of simple terms to express briefly the Oceanic zones, and have used the following:—

Epiplankton: 0 to \pm 100 fathoms below surface.

Mesoplankton: \pm 100 fathoms below surface to \pm 100 fathoms above bottom.

Hypoplankton: \pm 100 fathoms above bottom to bottom.

Epibenthos: high-water mark to the mud-line (generally at \pm 100 fathoms depth) = fauna of the continental shelf.

Mesobenthos: the mud-line (\pm 100 fathoms) to \pm 500 fathoms = fauna of the continental slope.

Hypobenthos: over \pm 500 fathoms = abyssal fauna.

This is not the place in which to discuss the justification of these terms: their intention will be apparent to all who have followed the recent progress of oceanic zoology. Two of them may be queried:—(1) the Hypoplankton, under which I reckon those floating and swimming animals (Crustacea, Fish, &c.) which, for nutrition and for other reasons, are more intimately connected with

certainly finished below the 100 fathoms), in all 30 hauls, with which to deal. Regarding, then, only those species which were captured six times, or in 20 % of the hauls, as affording a sufficient basis for discussion, we find that the occurrences of seven species work out thus, expressed in percentages of hauls made above and below 100 fathoms :—

	Epiplankton.	Mesoplankton.
<i>Calanus finmarchicus</i>	88.2 %	100.0 %
<i>Eucalanus attenuatus</i>	17.6 "	46.1 "
<i>Euchæta norvegica</i>	11.7 "	76.9 "
<i>Metridia longa</i>	23.5 "	69.2 "
<i>Pleuromma abdominale</i>	5.8 "	61.1 "
<i>Acartia clausii</i>	35.2 "	15.3 "
<i>Temora longicornis</i>	35.2 "	0.0 "

From this table it would appear (1) that *Calanus finmarchicus* is essentially eurythermal and eurybathic, *i. e.* has a wide range both of temperature and of depth; (2) that *Eucalanus attenuatus*, *Euchæta norvegica*, *Metridia longa*, and *Pleuromma abdominale* show a distinct preference for the deep water and low temperature of the Mesoplankton, although occurring more sparingly in the Epiplankton; (3) that *Acartia clausii* belongs rather to the Epiplankton than to the Mesoplankton; (4) that *Temora longicornis* is essentially a member of the Epiplankton. We may now compare these results, based unfortunately on but scanty data, with those recorded by others.

In the first place, *Calanus finmarchicus*, as mentioned above, has been recorded from most varied temperatures (latitudes), and is now definitely shown to extend to considerable depths (Sta. 18 b, 530–400 fm.). It does not occur among the Mesoplanktonic forms in Giesbrecht's list (*op. cit.* p. 788), and its vertical distribution in the Faeroe Channel is therefore worth recording. It is not at present safe to suggest a maximum temperature, as expressed by mean annual isotherms, for this species; it is, however, possible that its non-occurrence in the Equatorial region may indicate a maximum of 75° or 80° F. as its temperature limit.

In the second place, it is noteworthy that of the five species of Copepoda recognized by Chun¹ as essentially Arctic types (Leitformen), one is missing from the 'Research' collections (*Calanus cristatus*); one, regarded by Mr. Thompson as a species of doubtful

the bottom than with the Mesoplankton; (2) the Mesobenthos, which seems on statistical and other grounds to have certain marked features, both faunistic and physical, which distinguish it from the zones below and above it; although it shares many species with other zones, still, according to the 'Challenger' results (J. Murray, Summary of Scientific Results, Exped. H.M.S. Challenger, part ii. p. 1430, table 1), no less than 74 per cent. of its fauna is confined to it, and does not spread into other zones.

These six words, with the addition of the terms "oceanic" and "neritic" as applied respectively to the plankton of the open ocean and of the continental region, have been found in practice to serve sufficiently well for descriptive purposes.

¹ C. Chun, *op. cit.* p. 28. His list is a condensation from that of Giesbrecht, *op. cit.* pp. 776–7.

value, occurred rarely (*C. hyperboreus*); one, *Pseudocalanus elongatus*, is only represented three times, and cannot therefore be further discussed; two, *Metridia longa* Lubbock (= *armata* Boeck) and *Euchaeta norvegica*, are well represented. Both of these species exhibit, in the table of percentages above given, that preference for a mesoplanktonic existence which one would expect of an Arctic species in a Frontier district. For if the law be true, which was enunciated first, I think, by Moebius, that the area of distribution of a Planktonic organism is bounded at the surface by an isotherm and below by an isothermobath of the same number of degrees, we should expect Arctic forms to sink to lower (colder) depths as they approached lower latitudes (warmer surface-water). The southernmost points recorded in Giesbrecht's lists for these two species at the surface are—the northern part of the North Sea for *Euchaeta norvegica*, and Concarneau for *Metridia longa*. We are probably safe in assigning a maximum mean annual temperature¹ of 50° F. for *Metridia longa*, and a slightly lower mean annual for *Euchaeta norvegica*. In the very interesting collections made by Prof. Herdman in his traverse of the North Atlantic², the eight captures of *Metridia longa* were all near the mean annual isotherm of 50° F.; *Euchaeta norvegica* was not captured at all. As regards the vertical distribution of *Euchaeta norvegica*, the Norwegian North Atlantic Expedition failed to capture this species at the surface³, but it certainly comes to the surface in the Faeroe Channel, even in broad daylight (Sta. 11 c).

The other two forms, which, according to the table of percentages given above, exhibit an apparent preference for the Mesoplankton—*Eucalanus attenuatus* and *Pleuromma abdominale*,—are united in having a very wide superficial range in the Atlantic and Pacific Oceans; both occur in Giesbrecht's list of mesoplanktonic Copepoda, *Eucalanus attenuatus* being credited with 1000 m. = ± 550 fms., *Pleuromma abdominale* with 4000 m. = ± 2200 fms. Both these species must be regarded as eurythermal and eurybathic; and it is not at present possible to suggest a maximum or minimum temperature for either of them. Their apparent preference for the Mesoplankton in my collections must therefore be attributed to some other cause than temperature; but it is in no way inconsistent with what we already know of their habits.

Temora longicornis appears to be confined to the North Atlantic, except for two records from the Mediterranean which Giesbrecht appears to doubt⁴. So far as I am aware, it has never been recorded from any considerable depth, and with this my results accord: we may fairly regard it as a member of the Epiplankton;

¹ The mean annual temperatures are adopted from Buchan, Chall. Rep. Phys. Chem. ii. Atmospheric Circulation.

² W. A. Herdman, I. C. Thompson, and A. Scott: Trans. Liverpool Biol. Soc. xii. 33.

³ G. O. Sars: Crustacea of the Norwegian N. Atlantic Expedition, i. p. 240.

⁴ W. Giesbrecht, *op. cit.* pp. 328-330. Mr. Thompson informs me by letter that this species occurs also in a collection made at Muscat by Staff-Surgeon Bassett-Smith, R.N., of H.M.S. 'Cossack.'

and if it occurs between Newfoundland (mean annual isotherm 35° F.) and Muscat (mean annual isotherm 80° F.), it is remarkably eurythermal for an epiplanktonic animal.

As Mr. Thompson has mentioned, the occurrence of *Euchæta marina* so far north is remarkable. It has been recorded hitherto, according to Giesbrecht and Brady, in both Atlantic and Pacific Oceans, northwards from 47° S. (?) across the tropics, but with a northern limit in the Mediterranean. In Giesbrecht's list of mesoplanktonic species, it figures as from 4000 m.=2200 fms. to the surface. According to Brady¹, "it would seem to be the most abundant and most widely distributed of all the pelagic Copepoda," a description which it deserves more than ever, now that its range has been extended to the Faeroe Channel. In Prof. Herdman's traverse it was "found in the majority of the collections taken between mid-ocean and Quebec," *i. e.* across the mean annual isotherms of 35° to 50° F. Its extension northward in our longitudes is therefore by no means surprising.

The occurrence of *Euchæta barbata* and *Euchæta gigas* in the Faeroe Channel is most extraordinary. Both species have hitherto been taken only once, and then only together, *viz.* off Buenos Ayres (Challenger Sta. 325, 36° 44' S., 46° 16' W., down to 2650 fathoms). Their reappearance, still together, in northern latitudes makes it fairly safe to prophesy that the use of deep-water tow-nets in intermediate latitudes will prove them to be mesoplanktonic species of wide distribution.

Euchæta hessei (G. S. Brady), which, as Giesbrecht suggests, is perhaps identical with *Euchirella rostrata* (Claus), is known sparingly from both Atlantic and Pacific Oceans; its distribution is considerably extended by its occurrence in the 'Research' collections.

Euchirella pulchra has been recorded, according to Giesbrecht, only from the Gulf of Guinea, N.W. Africa, and South America. *Phaenna spinifera*, *Leuckartia flavicornis*, and *Heterochæta spinifrons*, according to the same authority, are known only from the Mediterranean (including the Canaries) and from the tropical Pacific; only the last of these occurs among the species taken in Prof. Herdman's traverse of the Atlantic; their range is now extended northwards to the Faeroe Channel. They illustrate well how impossible it is at present to draw distributional areas for most Copepoda; this group of Crustacea will probably rival the Radiolaria in the width of its distributional area, owing to the hardness and tenacity of life of many of its members. But—if we bear in mind that this is a Frontier district, *i. e.* one where a heavy slaughter of the Plankton occurs at the meeting of warm and cold currents, as is evinced by the abundant formation of glauconite and phosphatic nodules in the bottom deposits², and by the wealth of the benthos,—

¹ G. S. Brady, Chall. Rep. Zool. viii. Copepoda, p. 62 (*Euchæta prestandrea*).

² For the glauconite, see Tizard and Murray, Proc. Roy. Soc. Edinburgh, i. pp. 671 *et seqq.*—"There were no very large phosphate nodules, but numerous small ones, with phosphates in varying quantities," in a letter from Sir John Murray.

it is not a little suggestive that the above four species (to which may perhaps be added *Euchaeta hessii* and *Candace truncata*), which appear to have wandered north of their usual habitat, were only taken in the 'Research' from the Mesoplankton, and in all cases marked by Mr. Thompson as "Scarce." All six occurred once only, except *Euchaeta marina*, which was captured twice. It seems at any rate possible that these wanderers had either been killed by a reduced temperature, or at any rate so numbed by cold as to be gradually sinking to the bottom.

Acartia clausii of Giesbrecht has been separated by that author from *A. (Dias) longiremis* of Lilljeborg; he uses the latter specific name for species from the Baltic and Sound only. Assuming his view to be correct, the area of *A. clausii* has been somewhat extended northwards by the 'Research' collections: it reaches southwards to the Canary Islands, including the Mediterranean. I gather, however, from Mr. Thompson that he himself would prefer to regard the Baltic and North Atlantic forms as varieties of one species.

A. clausii appears to have been known hitherto as an epiplanktonic form only¹. Possibly its occurrence in deep water, at Station 20, may be due to dead or numbed specimens sinking from the surface; but it was so regular in its appearance on that occasion (in three out of four mesoplankton hauls), that, if the above explanation be correct, a very large swarm of this species must have succumbed to cold recently. As it did not occur in my mesoplankton hauls in 1896, I should prefer to leave the question open.

Rhincalanus cornutus and *Aetidius armatus* have been sparingly recorded from both Atlantic and Pacific Oceans, but not, so far as I know, from as far north as the Faeroe Channel.

As regards the remaining species in Mr. Thompson's list, there does not appear to be anything of mark connected with their appearance in the 'Research' collections, with the exception of *Argulus* (cf. p. 544).

The following conclusions as to vertical distribution appear to be justifiable on a comparison of the 'Research' collections with other records:—

Calanus finmarchicus is eurythermal and eurybathic.

Metridia armata and *Euchaeta norvegica*, two essentially Arctic types, tend to descend to the Mesoplankton on reaching lower latitudes.

Eucalanus attenuatus and *Pleuromma abdominale* are apparently eurythermal and eurybathic.

Temora longicornis and *Anomalocera patersoni* are apparently confined to the Epiplankton.

¹ F. Dahl, Verhandl. deutschen zool. Gesellsch. 1894, p. 64.

5. Contributions to our Knowledge of the Plankton of the Faeroe Channel.—No. V.¹ Report on a Collection of very young Fishes obtained by Dr. G. H. Fowler in the Faeroe Channel. By ERNEST W. L. HOLT.

[Received June 18, 1898.]

(Plates XLVI. & XLVII.)

My friend Dr. G. H. Fowler has asked me to name, if possible, the fishes taken in his vertical self-closing tow-net in the Faeroe Channel. My task is rendered the easier by the fact that the greater number of them prove to belong to one species. Individually some of the stages represented could hardly be definitely identified, even generically, but the series is practically complete and has enabled me to add considerably, as I venture to suppose, to our knowledge of the developmental phases of deep-sea forms. Incidentally the species in question, *Scopelus glacialis*, is definitely added to the British fauna, though that is a matter of no great importance. In the case of a pelagic egg and some early larvæ of very elongate form, I have only been able to point out the possible affinities. Two other larvæ, those of *Sebastes norvegicus* and *Gadus aeglefinus*, have already received attention at the hands of other observers, but the collection furnishes a stage of *G. aeglefinus* that has not hitherto been adequately described. The importance of a really efficient self-closing net, even from the point of view of the mere ichthyologist, can hardly be overrated.

SEBASTES NORVEGICUS Ascan. Norway Haddock.

Sebastes marinus, Collett, Norw. N. Atlant. Exped., Fish. 1880, p. 15, pl. i. figs. 3, 4.

Collett refers to this species a number of larvæ or fry which were taken at the surface "in mid-ocean, some nearly 400 kilom. from land," off Beeren Island and Spitzbergen. His examples measured from 9.5 to 19 mm., and two, illustrating the extreme terms of the series, are figured. In the brief description appended the character of the interorbital space and other obvious points of distinction from *Scorpena dactyloptera* are not mentioned; but we are not entitled to suppose that so careful an observer would have overlooked the possibility of confusion between the two forms.

Dr. Fowler's specimen, 12.5 mm. in length (inclusive), corresponds so closely to Collett's figures (allowing for the difference in dimensions) that it is unnecessary to illustrate it. It appears to be nearly identical in development with a North Atlantic specimen of 12 mm., but the bony ridge of the nape terminates in a single instead of in a double spine. The interorbital space is, in the Faeroe Channel larva, very wide and flat, a character in which

¹ For Part I. see P. Z. S. 1896, p. 991; Part II., 1897, p. 523; Part III., 1897, p. 803; Part IV., *antèa*, p. 540.

the adult *S. norvegicus* differs most strikingly from *S. dactyloptera*. I infer, from the condition of young examples of 40 mm., that the approximation of the eyes manifests itself, in the last-named species, at a very early stage.

The specimen occurred at 60° 2' N., 5° 49' W., 100 to 0 fath. Fragments of a little fish, taken at 60° 16' N., 5° 49' W., 200 to 100 fath., seem to have belonged to a member of this species, about 20 mm. long.

Collett records examples of 62 to 143 mm. from the bottom at 120 to 150 fathoms. If I have correctly identified Dr. Fowler's larger specimen, it would appear that the younger stage occurs in mid-water as well as at the surface.

GADUS ÆGLEFINUS Linn. Haddock. (Plate XLVII. fig. 12.)

Gadus æglefinus, G. O. Sars, Rep. Cod Fish. Lofod. (1866, 1867), in Comm. Rep. U.S. Comm. Fish. Fisher. (1877), 1879, p. 590; McIntosh, 15th Rep. Fish Bd. Scot. 1897, p. 196, pl. v.

The collection contains only one Gadoid, viz. a *Gadus* measuring 8 mm. without the caudal rays and terminal process of the urochord. It is in a good state of preservation, and may be identified with approximate certainty as a young Haddock. The eggs and very early larvæ of this fish are well known¹, and later stages, from 19 mm. upwards, have been well figured by McIntosh. Intermediate conditions have received less attention. Such were known to G. O. Sars, who probably studied them exactly; but, in the only account which I have seen, the Norwegian observer simply remarks that they are distinguishable from corresponding stages of the Cod, *G. morrhua*, by their shorter and stouter shape. McIntosh describes very briefly some specimens of 7 to 8, 11, 12.5 and 19 mm., which he attributes to the Haddock. He supposes that the smaller of the series correspond to the stages taken by Sars.

My figure (Plate XLVII. fig. 12) shows what I suppose to be the essential features of the Faeroe Channel specimen. The proportions and conformation being accurately drawn, need no elaborate description. As in the case of the young Haddock studied by Sars, the form is much more massive than in the Cod. This is seen at once on comparing my drawing with Prince's figure of a Cod, .33 in., 8.25 mm. *ca.* The total length is about the same, but the larval Cod is much more slender and appears less advanced in general development. The eye is also smaller. Probably whatever postmortem shrinkage may have occurred in one specimen is compensated by a similar condition in the other, and even if the Cod were drawn from a living specimen the difference in conformation is too striking to be entirely explained by a possible distortion of the supposed Haddock. In the latter the pelvic fins are indicated, if at all, by a very slight prominence of the thoracic region. The dorsal and anal fins are indicated by the inflections of the embryonic fin, but only a few of the permanent fin-rays are

¹ *Vide* McIntosh and Prince: Trans. R. S. Edin., xxxv. 1890, p. 822.

in visible process of development. The caudal fin shows features of interest. The extremity of the notochord forms the axis of a lanceolate mass; its extremity is bent up at an obtuse angle, and a considerable part projects freely, being succeeded, to the margin of the fin, by fine embryonic rays. Dorsally occur 12 rays, or 11 and a mass of embryonic rays dividing the last true ray from the urochord. None of these show any distinct basal element. Below the urochord is a roughly trigonal hypural lobe bearing five rays. Anteriorly are three smaller oblong lobes, the most posterior bearing two, the others one ray each. In front occur 6 rays. None of these caudal rays are perfectly formed, the anterior rays, dorsally and ventrally, being but little different from the embryonic rays in front of them. The notochord is still imperfectly segmented, and the myomeres cannot be counted with accuracy. These characters, therefore, like the fin-ray formula, are not available as aids to specific determination. Preserved in formol the specimen naturally possesses no yellow pigment, if any ever were present. The black chromatophores have the distribution shown in my figure on the left side. On the right side there are in addition a few scattered chromatophores. The roof of the peritoneum is seen to be densely black when the specimen is clarified. McIntosh makes no mention of the caudal pigment-bar which is such a prominent feature in the Faeroe Channel *Gadus*. The chromatophores above the insertion of the pectoral in the latter probably correspond to "a very distinct area of pigment-points behind the pectorals" in Scottish larvæ of 11 mm., and ultimately perhaps to the more posteriorly situate spot of the adult. The development of pigment in Teleostean larvæ is undoubtedly influenced to some extent by conditions of light and, apart from this, is variable in individuals. Probably such differences of coloration as may exist between the Faeroe Channel specimen and those attributed to the Haddock by Professor McIntosh are explicable in this way, but the information afforded, both as to pigment and conformation, in the case of the latter only permits of a conjecture as to their identity. The Scottish examples of 24 mm. and upwards, which are figured and adequately described, are undoubtedly Haddock, and appear to be certainly derivable from such a stage as is exemplified in the larva from the Faeroe Channel.

Dr. Fowler's specimen was taken at 60° 2' N., 5° 49' W., at 100 to 0 fathoms. I have myself recorded the capture of spawning Haddock at 154 fath., off the W. coast of Ireland, while Grimsby line-fishermen have told me that they frequently take the species at depths of more than 100 fath. on the wide area which they include in the Faeroe Bank.

SCOPELUS GLACIALIS Reinh. (Plate XLVI. figs. 1-5; XLVII. figs. 6, 7.)

S. glacialis, Günther, Chall. Rep., Zool. xxii., Deep-Sea Fishes, p. 196; Lütken, Spol. Atlant., Scopel. 1892, p. 30 (250).

Myctophum glaciale, Smitt, Hist. Scand. Fish. ed. 2, ii. p. 941.

? *S. scoticus*, Günther, Chall. Rep., Zool. xxxi., Pelagic Fishes, p. 31.

S. mülleri, Collett, Norweg. N. Atlant. Exped., Zool., Fish. p. 158.

Benthosema mülleri, Goode & Bean, Ocean. Ichth. p. 76.

Young, imperfectly characterized stages of the *Scopelidae* have been a source of much labour to the various observers who have had occasion to name collections of this group, since it has been quite impossible to determine, in the absence of sufficient material, whether certain differences have a systematic or merely a developmental value. I think I am right in saying that the reproduction is quite unknown, and I can find no description of the early larvæ of any species. With regard to one, the efficiency of Dr. Fowler's vertical net appears to have supplied this want, as I find in his collection what appears to be a nearly complete series of *Scopelus glacialis*.

Though the method has its disadvantages, it appears necessary in the present instance to describe the different stages in the inverse order, commencing with the most advanced. This is a specimen of 58.5 mm., exclusive of the lower jaw and the caudal fin-rays¹. It has the adult characters peculiar to the species and, except that most of the scales have gone and some of the fin-rays are broken, is in good preservation. No description is necessary except for ontogenetic comparison. The radial formula is D. 13, A. 18. The eye is nearly three times as long as the snout, and is $\frac{5}{12}$ of the length of the head (12 mm.), which is equal to the height of the body at the shoulder and a little more than $\frac{1}{5}$ of the total length. The anal commences nearly opposite the middle of the dorsal. Adequate figures of the adult stage, which is practically exemplified in this specimen, are given by Goode and Bean and by Smitt, but in some copies of the Hist. Scand. Fishes the printing is very imperfect. A clear diagram of the photophores is given by Lütken.

Figures 1 to 7 (Plates XLVI. & XLVII.) represent younger stages in Dr. Fowler's collection. The most advanced of these, fig. 1, measures only 14.5 mm., and has no scales; but the condition of another specimen indicates that the body is covered under natural conditions with dark-coloured scales. The part shaded in my drawing remains, in formol, a bluish grey. The photophores, having the formula of *S. glacialis*, are intact. The radial formula is D. 12 or 13, A. 18. The proportions of the head, eye, and snout are respectively as 31 (= 4 mm.), 10, 7. The eye is thus much smaller, relatively, than in the specimen of 58.5 mm., and the snout longer. Considered in the light of the ordinary ontogenetic changes of these parts in Teleosteans, this condition would appear to prove that the two individuals belong to different species, since as a general rule the eye decreases and the snout increases as development advances. In *Scopelus*, as I shall show, this condition is reversed during some part of the metamorphosis of the larva.

¹ This limitation is implied in all measurements of total length in this paper.

A specimen of 13.5 mm. does not differ greatly from the last. It was evidently fully clad, in life, with dark-coloured scales. The radial formula is D. 11 or 12, A. 15 or 16. I can see no certain indication that any rays have been entirely lost.

A specimen of 12 mm. (fig. 2) has the radial formula D. 14 *ca.*, A. 18. There are no signs of scales. The photophores are incomplete, but such as are present correspond in position to those of fig. 1 and of *S. glacialis*. A low wrinkled ridge of skin occurs along the back from the nape to the first dorsal fin. The proportions of the head, eye, and snout are as 25 (=3.5 mm.), 7, 6. There is thus a further reduction in the eye and increase in the snout as compared with the 14.5 mm. stage; but I think it will be conceded that the two specimens (figs. 1 and 2) are specifically identical. A vertical from the commencement of the anal passes a little behind the front of the dorsal. The base of the adipose is more extended than in the last stage.

Fig. 3 shows a specimen of 11.5 mm. The radial formula is D. 14 *ca.*, A. 18 *ca.*, the rays being rather indistinct in the posterior parts of the fin. The adipose is continued forward by a fold of membrane, beset with numerous embryonic rays, reaching nearly to the base of the dorsal, but its permanent region is indicated by an interneural prominence of the dorsal contour. The proportions of head, eye, and snout are as 25 (=3 mm.), 7, 6, a further reduction of the eye being thus indicated. The specimen is drawn in a rather oblique position. Viewed in exact profile, the top of the eye does not quite reach the cephalic contour. No photophores appear to be fully developed, but one is indicated at the lower extremity of the preoperculum, while some pigment on the mandibles seems to be representative of others. A patch of pigment occurs on the isthmus. Except in the eyes no other external pigment is visible; but internally a black mass in the postero-dorsal part of the abdominal cavity, visible when the specimen is clarified, is probably associated with the air-bladder. The greater part of the abdominal cavity is occupied by a voluminous intestinal tract beset with transverse ridges. The liver is comparatively small, and occurs below the basal part of the pectorals. Posterior to this line the whole cavity, so far as I can see, is occupied by the intestine, which passes by a slight constriction into the pyriform rectum. The mouth is smaller than in the more advanced stages, a condition familiar in the ontogeny of the Salmon.

The most remarkable feature of the larva is a large bladder-like expansion of the skin of the dorsum between the head and the dorsal fin. In the present condition of the specimen it is somewhat collapsed and flattened, its edges projecting from the upper part of the sides. Figs. 3 and 4 show this structure from different points of view, the true dorsal contour being indicated in the profile drawing by a dotted line. It is obviously identical with the wrinkled fold already noted in the 12 mm. stage, which is the degeneration of what is evidently a larval organ. In the specimen

of 11.5 mm., the cavity contains an amorphous plasma, which disappears in a clarifying medium. The larvæ of many Teleosteans, e. g., *Gadus*, *Solea*, are characterized in the vitelligerous condition by an expansion of the anterior part of the dorsal marginal fin, the walls of which are separated and form a sinus of varying size filled by a transparent fluid¹. The fluid being lighter than the body and yolk, enables the larva to maintain a vertical position, as I have been able to note by watching larvæ of *Gadus luscus*, in which the sinus is well developed. Larvæ not furnished with such a sinus in the vitelligerous stage are seldom vertical in position when at rest, except in the case of large vigorous forms from demersal ova, in which the organs of locomotion are far advanced at the time of hatching. I regard the structure noted in our *Scopelus* larvæ as homologous with the sinus of early Gadoid and other larvæ. It may be, as Ryder supposes, a lymph-space, having nothing in common except contiguity and continuity with the embryonic fin-fold, but I think its function is primarily connected with equilibrium. The most remarkable feature is its persistence, in *Scopelus*, to a comparatively advanced stage of the general development. In *Gadus* &c. it appears after hatching and attains its greatest development at about the end of the vitelligerous period or a little after (as in *G. morrhua*, *teste* Ryder), but disappears, so far as my experience goes, before the permanent median fins commence to appear.

[(*Note added Aug.* 1898.) My friend and teacher, Professor Howes, has called my attention to the possibility of an homology between the dorsal sinus of the young *Scopelus* and a peculiar pad-like process at the anterior end of the dorsal marginal fin of the larva of *Rana alticola*, described by Mr. Boulenger in his Catalogue of the Batrachia. Through the kindness of the last-named observer, I have been able to examine a larva of *R. alticola*. In both cases the structures are continuous with the walls of the marginal fin, but they appear, at present, to have little else in common. In *Rana* the median pad is associated with paired organs of a similar nature, and all three are solid and (*teste* Boulenger) glandular. In *Scopelus* the thin-walled sinus is probably devoid of well-developed glandular matter, but the material is too valuable to be submitted to the arbitry of the microtome.

Although Dr. Fowler's youngest examples of *Scopelus* are too much injured to admit of an exact determination of the extent of the sinus, it appears probable that the latter covers an area sufficiently extended to include the sites of all the glandular pads of *R. alticola*. It is possible that the sinus is an organ of extreme antiquity, of which the isolated pads of *Rana* may be modern derivatives.]

In a specimen of about the same stage of development as that

¹ *Vide* Ryder, Rep. Comm. Fish. U. S. A. for 1885 (1887), p. 496, pl. i. This author does not regard the sinus as part of the larval fin-fold, though its walls are continuous with that of the latter.

last described, the dorsal sinus is collapsed and flattened from side to side, having therefore the appearance of a skinny median ridge. A similar condition appears to have almost certainly furnished the most striking feature of Vaillant's genus *Anomalopterus* (Exp. Sci. Travail. Talism., p. 160, pl. ix.), which is founded on a specimen of 60 mm. having a kind of adipose fold ("repli, sorte d'adipeuse") occupying the entire length of the back from the head to the dorsal fin. Presuming in an allied family such a developmental increase in the size of the eye as we have seen to occur in *Scopelus*, it appears to me quite possible that *Anomalopterus pinguis* is only a young stage of *Bathytroctes*, the dorsal fold being merely a larval sinus¹.

A younger stage of *Scopelus* is represented in the Faeroe collection by a larva of 8 mm. (as slightly bent), shown in fig. 5. The general conformation appears to clearly associate it with the stage last described. The proportions of head, eye, and snout appear to be as 15, 4, 3, but the posterior boundary of the head is ill-defined and may be farther back than is indicated by my measurements. Relatively to the snout the eye is certainly a little larger than in the last stage. There is a continuous marginal fold, ampullated in the anterior dorsal region, the walls of the sinus extending some little way on to the sides. The dorsal is represented by a prominent interspinous ridge, beset with embryonic rays, but destitute of definite permanent rays. The rest of the dorsal fold bears embryonic rays, the adipose being merely indicated by a prominence of the dorsal contour. Comparing the various stages observed, it would seem that the development of the adipose proceeds on the same lines as the first dorsal and anal, since in the 12 mm. stage (fig. 2) there is an indication of the formation of true rays, which, however, is never consummated. The caudal is in an advanced stage of the familiar metamorphosis, the tip of the urochord projecting very slightly. The anal, more developed than the dorsal, already shows the proximal parts of 16 true rays. Thickened processes of the body-wall external to the origin of the rectum probably represent the developing pelvic fins. The alimentary viscera appear to be in much the same condition as at 11 mm. The anterior part of the abdominal tract is masked by the base of the pectoral and the liver. The rest of the cavity is occupied by a voluminous intestine lined with well-marked annular or spiral ridges. There is little or no black pigment in the peritoneal roof. Externally black pigment is distributed as shown in fig 5. An aggregation near the lower end of the preopercular ridge and another above the middle of the anal fin appear to represent photophores, though no supra-anal photophore is indicated in the more advanced stage of 11 mm. There are about 33 myomeres, of which about 11 or 12

¹ In Vaillant's plate (*loc. cit.*) is a figure of *B. melanocephalus* above that of *A. pinguis*. Allowing for developmental changes on the lines indicated above the two are much alike, but the radial formulæ given in the text are not quite in harmony.

are abdominal. The posterior region of the tail is imperfectly segmented.

Two less advanced larvæ, 6·5 and 4·5 mm. in length, may be taken together. The smallest, fig. 7, has about 31 myomeres, some 14 overlying the alimentary tract. The tail is practically diphycercal. The specimen of 6·5 mm., fig. 6, has the caudal metamorphosis more advanced, and shows an early condition in the development of the anal fin. The alimentary canal is much alike in both, but in the smaller the anterior part is nearly straight. In the larger there is a slight post-œsophageal dilatation, presumably the stomach. This is followed by a (pyloric?) constriction, distal to which the gut at once expands and is slightly bent towards the left side in front. Posteriorly it tapers to the region of the rectal valve. I cannot detect distinct transverse ridges, but there are some indications of a folding of the lining membrane of the wider anterior part, and I think that this condition may well represent an earlier stage of the voluminous intestinal tract of the more advanced larvæ. A large stellate chromatophore in the abdominal roof, about midway between the supposed pylorus and the anus, apparently overlies a small vesicle, not very clearly outlined. This may represent the air-bladder, and there are indications of its connection by a duct with the anterior part of the alimentary canal. In both specimens the marginal fin-fold is much abraded, but is certainly ampullate in its anterior region. I have not attempted in my drawings to restore it to what may be presumed to be the natural proportions. The teeth are small and not very numerous. The proportions of the head, rather injured in both specimens, are, I think, correctly represented in the drawing¹.

The general conformation, proportions of abdomen, and a sufficient harmony in the number of myomeres seem to reasonably connect these larvæ with the smallest (8 mm.) of the series of *Scopelus glacialis*². It may be objected that in the undoubted *Scopeli* of 11 mm. and upwards, the proportions of snout and eye have been shown to change in a manner inverse to that which obtains in the two smallest larvæ. I think, however, the increase of the eye is a secondary condition of comparatively recent establishment. In the earliest stages I imagine that the eye and snout retain the proportional metamorphosis common in the development of Teleosteans, the snout gradually elongating as development proceeds. This would go on until the attainment of a condition roughly corresponding to that shown in fig. 5. Thereafter the eye commences to increase in size until the adult proportions are attained. Such a condition appears to me more natural than an entire inversal of the metamorphosis whereby the ordinary proportional growth of eye and snout would be reversed from the earliest stage of larval development. In *Arnoglossus laterna* the

¹ The specimen of 6·5 mm. has only one eye, which, whether naturally or otherwise, is oblique in position.

² For an intermediate specimen, see note on p. 560.

eye of the male is known to enlarge as a secondary sexual character associated with the development of other structural changes; while according to Grassi¹ the Common Eel (*Anguilla vulgaris*) acquires large eyes in deep water and in the Roman cloacæ. The secondary enlargement of the eye in *Scopelus* is thus not without parallels. *Scopelus* is, I suppose, a form driven from littoral regions to a pelagic and bathybial mode of life, involving an enlargement of the visual apparatus.

Among the pelagic fishes enumerated by Günther in his 'Challenger' monograph (vol. xxxi.) are mentioned a number of small *Scopeli* taken by the 'Triton' in the Faeroe Channel (*loc. cit.* p. 31). While recognizing the close resemblance which these forms bear to *S. glacialis*, the author considers that certain characters deserve specific distinction, and has accordingly described them under the name of *S. scoticus*.

The largest specimen measures 14.5 mm., that is, exactly the same as the *S. glacialis* shown in figure 1. In the dimensions of the eye (naturally considered by Günther, in the absence of any information of the developmental changes of this organ, of importance) the two forms are in practical agreement. The contour of the snout appears to agree with the corresponding stages in Dr. Fowler's collection. The posterior margin of the preoperculum is described as vertical in *S. scoticus*, it is rather oblique in *S. glacialis*. In the characters of the maxilla the two forms agree. The photophore formula is described as identical with that of *S. glacialis*. In *S. scoticus* the origin of the dorsal is nearer to the root of the caudal than to the tip of the snout, and is behind that of the pelvics. In *S. glacialis* of 14.5 mm. the dorsal arises midway between the snout and the caudal; in a specimen of 11 mm. it is a little nearer to the latter; and comparison of the several young stages suggests that in relation to the two points named there is during development a slight variety in the position and perhaps a developmental migration of the fin. It is behind the base of the pelvics even in adults. Younger stages do not differ in any important detail described from those in Dr. Fowler's collection, but specimens of 9 mm. are stated to have the fin-rays perfectly differentiated. In this case the length given appears from the context to include the caudal fin. One specimen of 8 mm. (without caudal) has the rays of the dorsal still undifferentiated. Individual variation in the degree of development at a given size is, however, a common feature in Teleostean ontogeny. The radial formula of *S. scoticus* is stated as D. 10/11, A. 16. That of *S. glacialis* is, according to Goode and Bean, D. 12-14, A. 16-18. In Dr. Fowler's specimens the formula, as we have seen, is D. 12 or 13 to 14 (?), A. 18 and 18 ca., with the exception of one which has only D. 11 or 12, A. 15 or 16. This last specimen is one of the most advanced, in good preservation, and of nearly the same size as another, from which it differs in no detail except the number of fin-rays. I believe that all Dr. Fowler's *Scopeli* can

¹ Q. J. M. S. xxxix. 1896, p. 385.

safely be assigned to *S. glacialis*, and am strongly inclined to consider that *S. scoticus* must be relegated to the synonymy of that species.

In all 15 specimens were obtained on the 'Research.'

Sta.	Depth in fathoms.	Temp. Fahr.	Spec.	Length in mm.
13 b.	300-170	o o	1	14.5 ca.
13 e ¹ .	400-270	32-38	{ 2	6.0, 6.5 ca.
			{ 3	11.0 to 14 ca.
13 g.	465-335	31-33	1	14.0 ca.
13 i.	100-0	48-54	3	4.5, 7.5, 8.0.
15 c.	50-30	30-53	1	58.5.
16 a.	350-170	31-44	{ 2	12 ca.
			{ 1	larger injured.
19 a.	480-350	46-47	1	14.5.
20 c.	400-300	31-33	1	13.5.

¹ 13 e is suspected of having closed nearer to the surface than the depth here recorded; till all its contents have been identified, it is to be regarded as doubtful.—G. H. F.

Many of these specimens have been more or less injured, but all can be clearly associated with the series which I have described. Günther, Collett, and Goode and Bean agree in regarding *S. glacialis* as a truly bathybial species; but Dr. Fowler's self-closing net furnishes us with the first certain evidence of its vertical distribution. It extends evidently to at least 350 fath., the specimen taken at 480 to 350 fath. being one of the most advanced of the series (fig. 1). This latter specimen enables us to add *S. glacialis* to the British list, the locality lying within Norman's British Area (Ann. Mag. Nat. Hist. 1890, v. p. 345). All the other specimens occurred just outside this area as did also the 'Triton' specimens (*S. scoticus*); the latter were taken in the Faeroe Channel "partly with a surface-net at night, partly with the tow-net, which with a line of 350 and 600 fathoms was worked at various depths" in the Cold Area.

S. glacialis is known from the Northern coasts of Norway, coast of Greenland, Arctic Ocean, and various localities in the American North Atlantic.

[With regard to the vertical distribution of this species,—in the first place, it appears to be essentially a cold-water form. Collett¹ records it as having been taken by the 'Vöringen' once "found floating," and once (three specimens) from 1110 fathoms west of Hammerfest. Previously to this expedition it had been known only from Greenland and Northern Norway. It has since been taken by the 'Blake'², at considerable depths only, off the coasts of New England and South Carolina, in the cold undertow which passes under the Gulf Stream and whose upper edge forms the Labrador current and its continuation southward.

¹ Norweg. North Atlantic Exped., Fishes, p. 112.

² Goode & Bean: Bull. Mus. Comp. Zool. Harvard, x. p. 222 (1883).

Secondly, like many other cold-water forms, it appears to be eurybathic in high latitudes; the difference in temperature between the superficial and deeper water being comparatively small, and offering no marked thermal barrier to its descent.

Lastly, as regards the Faeroe Channel, it is noticeable that no specimens, larval or adult, were taken at the actual surface in twenty-five hauls; that the smallest specimen of all was captured nearest to the surface, between 100-0 fathoms (Sta. 13 i.); that other larvæ were taken in six out of the thirteen deep hauls, and may thus fairly be ranked among Mesoplankton. One (?) adult specimen was taken in a haul which began at 530 fathoms and finished at the surface; this unfortunately gives us no help. Although none of the 'Research' specimens were captured at the surface, still if, as Mr. Holt suggests, Dr. Günther's *Scopelus scoticus* is identical with these larvæ, some larvæ come to the surface at night in the Faeroe Channel.

Though more observations are required for confirmation, still it seems probable that *Scopelus glacialis*, at any rate as regards the Faeroe Channel, falls into the category of animals which have an early epiplanktonic stage, but frequent greater depths when adult (cf. p. 578, *infra*). Even in higher latitudes the adult has been most frequently recorded either from considerable depths, or as dead and floating if at the surface.—G. H. F.]

[*Note added Aug. 1898.*—The stages shown in figs. 5 & 6 are connected by an intermediate specimen of 7·5 mm., received too late for description in the text. The proportions of the head, eye, and snout are as in the specimen of 8 mm., but the general form is more slender.—E. W. L. H.]

IMPERFECTLY CHARACTERIZED LARVA with very elongate abdomen. ? *MALLOTUS VILLOSUS* Müller. Capelin. (Plate XLVII. figs. 8-11.)

These very elongate larvæ have at first sight much the appearance of young Eels, but closer inspection soon dispels this illusion. They measure respectively 17, 19 (*ca.*), and 24·5 mm., from the snout to the extremity of the notochord. I have figured the most advanced, which on the whole is the most perfect specimen of the series. The others differ little in general conformation, but the smallest has the caudal extremity still practically diphycceral, and the marginal fin terminates, without spatulate expansion, in a sharp lanciform process. The proportionate lengths of the abdominal and caudal regions are shown in Plate XLVII. fig. 8; it will be seen that the abdomen is about twice as long as the tail, the rectum being thus given off at a point far posterior to median. The fore-brain extends but little in front of the eye, which is only of moderate proportions. The considerable bluntly-rounded rostral region is occupied anteriorly by a large olfactory pouch. The angle of the jaws is opposite the front of the eye. The pectorals are small. The pelvics are indicated by a pair of membranous lobes supported anteriorly by

a thickened fleshy rim. They are situate at about the middle of the total length of the larva, and well behind the middle of the abdominal region. The liver occurs as a small pyriform mass shortly behind the clavicle. The alimentary canal, apparently wide and thin-walled in the thoracic region, is soon constricted and thickened. Its ventral wall shows a downward crenulation (about halfway between the clavicle and the pelvics) which may be accidental. At the pelvic region commences a well-marked intestinal tract lined with transverse (annular, perhaps spiral) ridges. The short and rather voluminous rectum leaves the trunk in an oblique direction.

There are 47 abdominal (counted to the origin of the rectum) and 20 caudal myomeres visible: others may probably be seen at a later stage, but the total number will not be much greater than 67. Black pigment is present in a series of ventral spots, seven in number, distributed at regular intervals from the clavicular region backward. These consist for the most part of a single chromatophore on either side of the gut, but at the shoulder there are several, as also at the region of the rectal valve. The pre-peduncular spot of the tail consists of two ventral and one lateral chromatophore. The caudal fin, both as to the embryonic and permanent parts, is rather profusely decorated with small black dots. The eyes are deeply pigmented. The dorsal marginal fin is wide. Anteriorly it is rather imperfect in the specimen figured. In that of about 19 mm. the fin appears to be ampullate anteriorly, and this is probably the natural condition in the others also. There are no signs of the permanent dorsal and anal fins, but embryonic rays occur in the postanal region.

On comparison of the three examples it would appear that the ventral spots become reduced as development advances. Though identical in number those of the largest individual are relatively considerably smaller than those of the younger.

I have noticed elsewhere (p. 565 *infra*) the occurrence in Dr. Fowler's collection of a pelagic egg, which, as far as may be judged from the preserved condition, appears to be practically identical with Raffaele's species No. 7 (Mitth. zool. Stat. Neap. viii. 1888, p. 69). In conformation and in distribution of pigment the form which we are now dealing with bears a striking likeness to the larva of Sp. 7 (*op. cit.* tav. v. fig. 9). The ventral spots are numerically equal, and there is an indication in the Faeroe larva of the large "rhomboidal" supra-cephalic sinus described in Sp. 7. The latter is stated to have 59 or 60 abdominal segments, a condition which indicates that the total number is considerably in excess of that present in the much more advanced Faeroe larva, and so disposes of the possibility of the formula being harmonized in the two forms by a developmental migration of the anus. The marginal fin, though wider in the Faeroe larvæ, terminates, in the youngest example, as in Sp. 7; and in the anterior dorsal region appears to be inflated alike in both forms. But none of the Faeroe larvæ show any trace of the prodigious buccal armature of Sp. 7. The teeth, on the contrary, are quite small.;

Sp. 7 is one of a group of ova and larvæ which Raffaele considered to exhibit Murænid affinities; and Grassi has practically confirmed the correctness of this view in the case of at least one species, No. 10, which he has connected with *Anguilla vulgaris*. Moreover it appears probable that all Murænid larvæ pass through a *Leptocephalus*-stage, losing the buccal armature of what Grassi terms the pre-larval condition. I imagine that it is impossible to connect the Faeroe larvæ with either end of a Leptocephaline metamorphosis; while the condition of the intestine and the caudal fin suggest for them affinities which are not Murænid. The presence of pelvic fins can hardly be held to prove that they are not Murænoids; at least until Grassi shall have found that such structures never occur as vestigial phenomena in the development of Eels¹.

In 1893 my friend Captain F. Klotz, s.s. 'Dominican,' brought me a number of young fish which he had taken at the surface off the West Horn of Iceland on the 27th July. They range in size from 36 to 57 mm., and in general shape have much the appearance of Sand-eels (*Anmodytes*). The collection is sufficiently serial to show that only one species is present, while the largest appear to associate themselves with the Capelin, *Mallotus villosus*. I have figured the head of the smallest (fig. 9), a specimen of 42.5 mm. (fig. 10), and the largest (fig. 11). The radial formula of the largest appears to be D. 12 (or a few more), A. 21. This specimen has 64 myomeres (perhaps more, as the pectoral region is lacerated) exclusive of the peduncular part of the tail, where a few others are probably present, though not sufficiently defined to be counted. About 49 are abdominal. From the ocular region backward the head is distinctly trigonal in section, the upper surface being flat while the sides approach each other ventrally. Though this is rather less marked in the buccal region, there is a distinct approach to the conformation (a three-sided pyramid) described by Smitt (Hist. Scand. Fish. ed. 2, p. 877) as characteristic of the head of the adult Capelin. The sides of the body are compressed and flattened, while the dorsum is also rather flat. *Mallotus* has the radial formula D. 12-16, A. 18-25; the vertebræ are from 65 to 70. In general proportions and in the relative position of the fins the oldest Iceland specimen is in agreement with *Mallotus* (compare Smitt's figures of the latter, *op. cit.* pl. xli. with my figure 11). The Iceland specimens are a good deal damaged and none have any scales on the body, but there are traces of them on the gill-cover of the largest. The teeth are small, and there is no distinct notch in the premaxillary region for the reception of the mandibular extremity.

Beyond a few remarks of Collett's, quoted by Smitt, I have not found any description of the young stages of *Mallotus*. Our

¹ Lütken ("Spol. Atlant., Changements de forme chez les Poissons," Vid. Selsk. Skr. 5. Række, 1880, p. 594) considers that pelvic fins probably exist in the young of all species of *Trichiurus*, though their presence is only indicated in the adult of one species.

Iceland forms show a certain resemblance to the genera *Paralepis* and *Sudis*. *Paralepis borealis* is known from Greenland, Iceland, and the North-American coast. Apart from other differences, the excessive number of anal rays and the large size of the teeth (*vide* Goode & Bean, Ocean. Ichth. p. 119, fig. 143) serve to separate it from the forms before us. *P. coregonoides* has occurred in the Mediterranean and on the American Atlantic coast, and may well exist in Boreal European waters. It appears to agree better than the last with the Iceland forms, but has the generic character of very large teeth. *P. sphyronoides*, from the Mediterranean and Madeira, has 30 anal rays. I cannot ascertain the vertebral formula of any of these species. Under the name of *Sudis atlanticus* Smitt gives a brief account, derived from Krøyer, of a fish washed ashore at the Skaw. It had 20 anal rays, and so far as I can judge its young stage might bear some resemblance to the Iceland specimens. The balance of probability, however, appears to me to favour the association of the latter with *Mallotus villosus*¹, although, so far as I know, the Capelin has never been recorded from Iceland.

The smallest Iceland specimens bear a considerable resemblance to the largest of Dr. Fowler's larvæ. In the latter (fig. 8) the snout is obtuse and rounded except at the extremity. In the former (fig. 9) the snout is more pointed, but still somewhat rounded superiorly. A depression behind the eyes indicates the collapse of a sinus over the hind-brain, such as seems to have been also present in the Faeroe larvæ. The specimen 36 mm. long has the greatest height of the body only 2.5 mm.; the form being thus extremely elongate. The gradual increase in height is illustrated in figs. 10 and 11.

Most of the Iceland forms have only a few chromatophores scattered along the ventral surface, but one, about 42 mm., has a number rather widely diffused over the general surface of the head and body. How far the generally unpigmented condition is natural I cannot say.

A size-interval of 11.5 mm. separates the largest of the Faeroe larvæ from the smallest of the Iceland series. Since in the former the isolated spots of the ventrum appear to be in process of reduction, their absence in the latter is not necessarily a bar to the association of two series. The Faeroe larvæ have certainly a smaller eye than the Iceland forms, but we have evidence of a developmental increase in the size of this organ in *Scopelus* which may well be repeated in other fishes of similar environment. In the Iceland series the proportions of the eye are variable; but in the larger and more perfect examples an increase is associated

¹ Dr. Günther considers that a number of larval forms, corresponding to Richardson's genus *Prymnothonus* (*vide* Chall. Rep., Zool. xxxi. Pelag. Fish. p. 39, pl. v.), "represent larval conditions of fishes belonging to *Paralepis* or *Sudis* or of genera allied to them." I venture to suggest that in the genera named the abdomen will be found to be much more elongate, from the earliest stages, than in *Prymnothonus*.

with advance of general development. In the number of myomeres both Faeroe and Iceland forms agree well enough with *Mallotus*.

The latter has not been recorded from any point nearer to the Faeroe Channel than the coast of Norway, but appears to be a fish of pelagic habit, approaching the coast only for the purpose of spawning. The ova are demersal, and it may be objected that our Faeroe larvæ are too young to be found so far from land. This objection depends for its validity on a knowledge of the rate of growth, which is not forthcoming.

Although I think I have demonstrated the possibility of connecting the Faeroe larvæ, through intermediate stages as represented by the Iceland series, with the adult form of *Mallotus villosus*, I do not think we are justified in considering the question settled. The fact is that we know next to nothing of the development of many marine forms and especially of the pelagic and bathybial species, nor can it be supposed likely that a few sporadic cruises have furnished us with an even approximately complete list of the fish-fauna of the Faeroe Channel. In all probability there is a strong resemblance between the larvæ of many physostomous fishes, however widely they may be separated in the adult condition. Of the method of reproduction of bathybial fishes, whether by pelagic or demersal ova, we are in most cases ignorant. The characters of the Faeroe larva, though probably sufficient to exclude it from the Murænidæ, are such as might occur equally in a Salmonoid, Scopeloid, or Clupeoid. Any Clupeoids known as inhabitants of the region may be eliminated, since we know the larval stages of all of them. The same remark applies, as I think, to *Argentina sphyæna*; specimens of 37 mm. have already acquired the adult conformation¹, though only about 13 mm. longer than the Faeroe example, which is still practically undifferentiated. The size-interval does not appear sufficient, and I imagine that this species of *Argentina* has a shorter larva, with, of course, fewer myomeres. *A. silus* has 65 to 68 vertebræ and is a much larger fish. It may conceivably pass through a larval stage like the Faeroe form if its pelvic fins undergo an anterior migration. Among the Scopeloids *Stomias* is an elongate form, and *S. ferox* has been recorded by Günther from the Faeroe Channel (Chall. xxxi. *op. cit.* p. 31).

However, the example in question, though capable of even specific determination, was again only 37 mm. in length; while I can find in the Faeroe larva of 24·5 mm. no trace of the barbel and enlarged teeth of *Stomias*. I have already referred to the characters of the *Paralepidæ*, and the enumeration might be prolonged but always without bringing us, for the present, any nearer to a definite conclusion.

Dr. Fowler's specimens were taken as follows:—

13 *i.* 60° 2' N., 5° 49' W. 100 to 0 fathoms. Two, 19 and 24·5 mm.

20 *c.* 60° 16' N., 5° 49' W. 400 to 300 fathoms. One, 17 mm.

¹ Holt & Calderwood, Trans. R. Dubl. Soc. ser. 2, v. 1895, p. 509, fig. J.

If they prove to be young *Mallotus* it will have been shown that form is capable of descending below the 300-fathom line. The localities are just outside the British area.

A PELAGIC EGG, resembling Raffaele's species No. 7.

? Raffaele, Mittheil. zool. Stat. Neap. viii. 1888, p. 69, tav. 5. Undetermined species no. 7.

Dr. Fowler's collection contains only one egg, which is quite unlike any that has been recorded from British or Northern European coasts. Preserved in a weak solution of formaldehyde, it was not sufficiently transparent for an exact determination of the internal structure. It was therefore passed through the usual reagents into oil of cloves, a process which unfortunately involved a complete collapse of the zona radiata. An attempt to remove the latter without injury to the contents was only partially successful. The characters, as observed during the whole process of manipulation, appear to be as follow:—

The diameter is 3.5 mm., the shape approximately spherical. The zona is thin and probably without any distinctive feature, since some bubble-like markings present on one part appear to be due to the adherence of a thin layer of yolk-matter. The perivitelline space is certainly large, but the exact dimensions of the yolk had been obscured by rupture either in the net or by the action of formaldehyde. The embryo remains attached to a pyriform yolk-mass 1.19 mm. by .90 mm., the narrow end underlying the head. The yolk is divided throughout into small rounded segments of irregular size, and appeared to possess, as seen in formaldehyde, a number of small oil-globules aggregated together. The embryo is advanced and has a considerable free tail, closely apposed to the yolk. Its total length may be estimated at about 2.40 mm. There appears to be no pigment. Any distinctive characters which may have been present could not be observed before the removal of the zona; and the specimen was too much injured in this process to admit of a reliable observation of the embryo.

Sufficient, however, has been noted to show that the egg agrees very closely, both in dimensions and other characters, with Raffaele's species no. 7. Grassi's researches¹ have confirmed Raffaele's suggestion of a Murænid parentage for at least some of the group of evidently allied ova to which no. 7 belongs, one of them, no. 10, having been connected in a practically conclusive manner with the Common Eel (*Anguilla vulgaris*).

No observer has yet described the perfectly ripe egg of the Conger (*C. vulgaris*), nor has any attempt been made to identify with this abundant and rather valuable form any egg taken in the tow-net. It appears from Cunningham's description (Q. J. M. S. xl. p. 155) that the ripe egg probably differs from that of *Anguilla* in possessing one or more oil-globules, and therein agrees with Raffaele's sp. 7 and with the egg from the

¹ Q. J. M. S. xxxix. p. 371.

Faeroe Channel. In eggs characterized by a large perivitelline space, such as those of *Hippoglossoides* and some species of *Clupea*, the expansion of the zona is known to be accomplished after deposition. The difference of dimension of the yolk-mass, as between sp. 7, the Faeroe Channel egg, and the largest eggs obtained by Cunningham from the Conger¹, does not appear to be considerable. The specific identity of the three appears at least possible.

On the other hand, it may well be that Raffaele's group of eggs belongs in fact to more than one family of physostomous fishes. I have described from Dr. Fowler's collection a series of larvæ, which are apparently not Eels, but which in conformation and pigment agree rather closely with the larva of Raffaele's no. 7, though they entirely lack the peculiar buccal armature of the latter. Such armature is, in the Eels, a very temporary phenomenon, the leptocephaline condition being devoid of it.

To attempt to connect the Faeroe egg with the elongate larva from the same region were simply an unprofitable speculation: but it may be suggested that the characters of segmented yolk and large perivitelline space, common to Murænidae and Clupeidae, may be equally present in the ova of Scopeloids and of such, if any, Salmonoids as propagate by means of pelagic eggs. In point of attenuation I know no larvæ more eel-like than some of the Clupeoids. I do not suppose that the egg with which we are dealing is that of a Clupeoid, but, whether it be identical with Raffaele's no. 7, or different, our knowledge of the development of the pelagic and bathybial members of the other groups mentioned is hardly such as to permit us to definitely assign it to any one of them. *Mallotus*, which I have suggested as a possible parent of the elongate larva, is known to deposit ova which are demersal in littoral waters. If any description of their structure exists I have not seen it.

EXPLANATION OF THE PLATES.

PLATE XLVI.

- Fig. 1. *Scopelus glacialis*, 14·5 mm., p. 552. Formol.
 2. " " 12 mm. Formol.
 3. " " 11·5 mm. Formol. The larval sinus in front of the dorsal fin rather collapsed.
 4. Dorsal view of the same specimen. Formol.
 5. *S. glacialis*, 8 mm. Oil of cloves.

PLATE XLVII.

- Fig. 6. *S. glacialis*, 6·5 mm., p. 552. Oil of cloves.
 7. " " 4·5 mm. Oil of cloves.
 8. " " Larva with elongate abdomen, 24·5 mm., p. 560. Oil of cloves.
 9. Head of young *Mallotus villosus*?, 36 mm., p. 560. From Iceland. Alcohol.
 10. Young *M. villosus*?, 42·5 mm., p. 560. From Iceland. Alcohol.
 11. " " 57 mm. From Iceland. Alcohol. Natural size.
 12. Young *Gadus æglefinus*, 8 mm., p. 551. Formol.

¹ Cf. Journ. M. B. A., n. s. ii. 1891, pp. 24-25.



1.x3-3



2.x3-3



3.x3-3

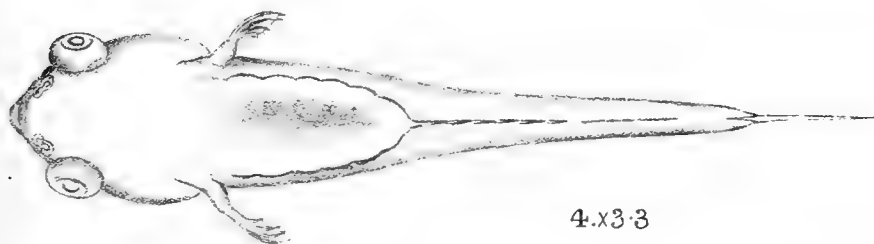

4.x3-3

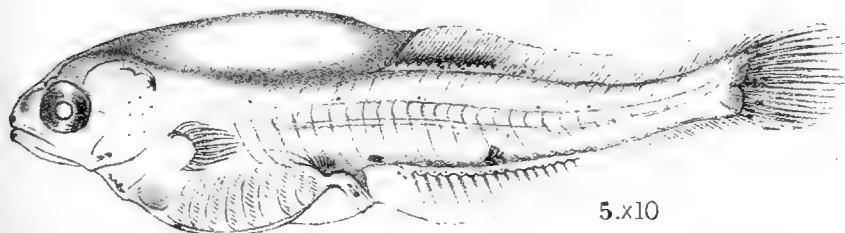

5.x10





6.x15

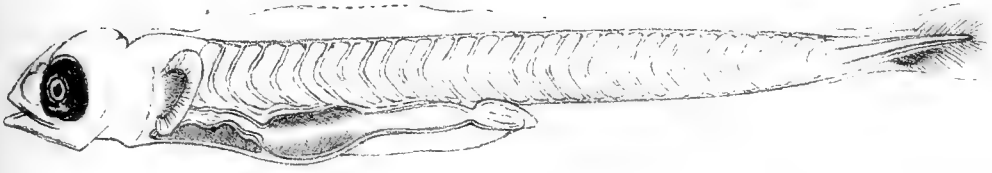

7.x24



8.x4

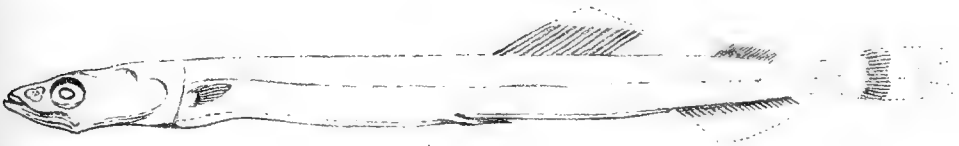

10.x2.25



9.x4.5



11.x1



12.x10.8



6. Contributions to our Knowledge of the Plankton of the Faeroe Channel.—No. VI.¹ Description of a new Mid-water Tow-net. Discussion of the Mid-water Fauna (Mesoplankton). Notes on *Doliolum tritonis* and *D. nationalis*, and on *Parathemisto abyssorum*. By G. HERBERT FOWLER, B.A., Ph.D., Assistant Professor of Zoology, University College, London.

[Received June 18, 1898.]

In the first paper of this series, I proposed to leave the description of the mid-water nets used, and the discussion of the general question of the existence of a mid-water fauna or Mesoplankton, until the collections made on the 'Research' had been thoroughly investigated. The net which I used last year proved so successful in actual working, that it now seems to me better to describe it at once for the information of other investigators, who might give it a further trial; the more so since my leisure for research work is but small, and the collections cannot be completely finished for some months to come.

It is unnecessary to describe here the numerous and varied forms of apparatus which have been devised for the capture of animals at known mid-water depths without admixture of the fauna from other zones. References to them will be found, by those interested, in the papers of Hoyle², H.H. the Prince of Monaco³, and Agassiz⁴; since the appearance of the last-named, a full description of the 'National' apparatus has been published by Hensen⁵. Agassiz, in the paper cited, has subjected the earlier forms of net to a searching criticism, with which I agree on the whole; except that of the Prince of Monaco and that of the 'National,' none appear to exclude satisfactorily animals from undesirable zones. Even that of the Prince of Monaco does not appear to have worked satisfactorily on the 'Pola'; and the modification of Chun's net used on the 'National' was uncertain in its action⁵.

When desirous to study for myself the question of a mid-water fauna or Mesoplankton⁶, I feared that both the nets last quoted were too expensive, and the 'National' net too complicated for use in such heavy seas as are generally to be found in the Faeroe Channel, the only deep-water readily accessible to me. Returning therefore to Chun's⁷ original ingenious design as a starting

For Part I., see P. Z. S. 1896, p. 991; Part II., P. Z. S. 1897, p. 523; Part III., P. Z. S. 1897, p. 803; Part IV., *antea*, p. 540; Part V., *antea*, p. 550.

² Proc. Liverpool Biol. Soc. iii. 100.

³ CR. Congrès international de Zoologie, Paris, 1889, p. 133.

⁴ Bull. Mus. Comp. Zool. Harvard, xxiii. 1.

⁵ Ergebnisse d. Plankton Exped.: Methodik der Untersuchungen p. 103 *et seqq.* (1895).

⁶ For the explanation of this and similar new terms used here, see p. 545 *ante*.

⁷ C. Chun: Bibliotheca Zoologica, i. 1

point, I endeavoured to introduce into it such improvements as would obviate what appeared to me to be its weaknesses, namely: (1) The position of the wires when the net had shut, which necessitate the mouth being always slightly open; (2) the lack of power to keep the net-mouth shut in a roll of the ship or a check on the line, as the attachments of the wires by which it then hangs are so close together; (3) the speed at which the whole structure must be towed in order that the screw-propeller, and the rod to which it is fixed, may overcome the frictional resistance offered by the rings on which the weight of the net is hanging.

I decided to construct a net for vertical and not for horizontal use, because it seems to me, on the basis of my small experience, impossible to be certain of the depth at which a net is being towed horizontally. The usual method for this is to lower the net vertically, and to begin towing with the rope straight up and down; then to observe the angle made by the rope with the horizon by means of a quadrant, and to calculate the vertical depth of the net by traverse tables on the assumption that the towing-line is the hypotenuse of a right-angled triangle. Unfortunately for this method, however, the towing-rope is not a hypotenuse, but forms an unknown catenary, which varies with the weight of the net, its resistance to the water, and the pace of towing; this forms an increasing source of error, the greater is the length of towing-warp out. As an example of the uncertainty of this method,—I struck bottom at 398 fathoms in the Faeroe Channel, when by quadrant and traverse tables the net should have been at 300 fathoms with 450 fathoms of rope out. There are so many forces at work as to make it impossible for any but a highly skilled mathematician to calculate the probable position of the net, and this only after tedious experiment.

Description of the Apparatus.

This consists of the net, the net-frame and chains, and the locking-gear. As the first of these were used both in 1896 and 1897, they will be described in detail; the locking-gear of the 1896 pattern will only be sufficiently sketched to enable future workers in this field to profit by my experience of failures; the 1897 pattern will be fully described.

The net is made of Swiss Silk Boulting Cloth, by far the best material known to zoologists for every form of tow-net; it was supplied by Messrs. Staniar of the Manchester Wire Works; this material will stand almost any fair pull, but, as it is very liable to be cut by anything sharp, when coming inboard, the actual net is surrounded by a loose case of common mosquito-netting. A net with a twenty-inch square mouth, tapered to a four-inch diameter cod-end, and six feet in length, was found to be a good working size. It should be sewn throughout by hand, not by machine; and with strong sewing-silk, not thread. If washed nightly in fresh water and dried in the air, a net of this sort will last for a very long time.

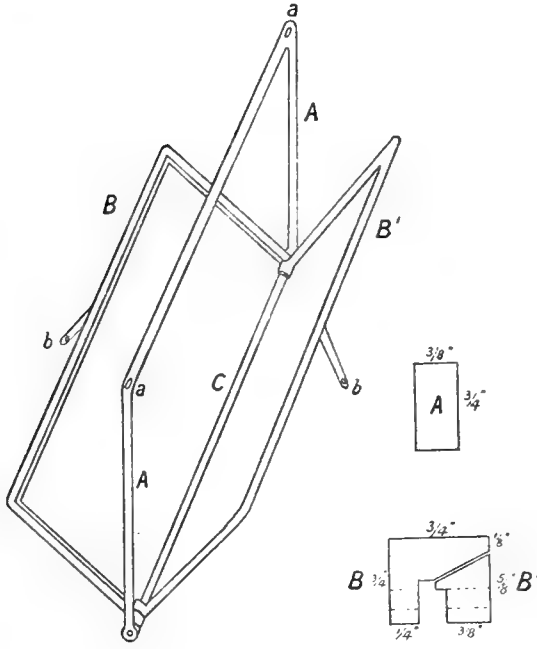

FIG. 1.

FIG. 2.

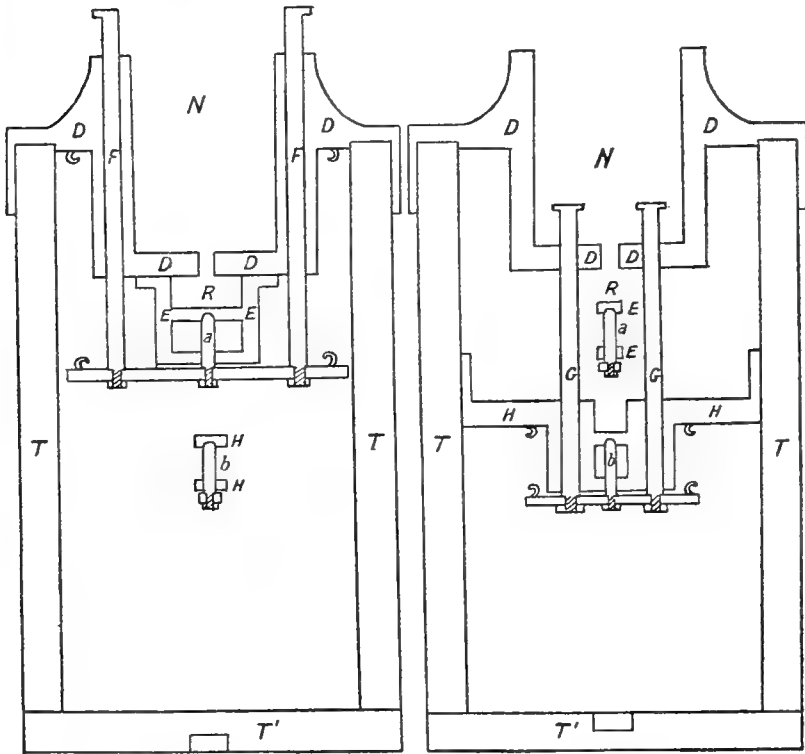



FIG. 3^a

FIG. 3^b

G. H. F. del.

As a mid-water net has to be drawn up by a steam-winch more rapidly than is usual with a surface tow-net, even when the winch is going its slowest, boulding cloth of twenty-five (1896) and forty (1897) meshes to the inch was selected; of these the second is stronger and more efficient. If the winding-drum can be run dead slow by gearing, 50 or even 60 meshes to the inch might be used. A calico band at the mouth pierced by lacing-holes, and a calico band at the cod-end, with a tape by which the collecting zinc pot is tied in, complete the net. The tape should run in loops *outside* the calico band, it is there much easier to untie with cold wet fingers.

The **net-frame** (fig. 1, where it is represented as half open) consists of two  shaped phosphor-bronze castings **BB'** hinged together on a solid brass axle **C**; on to the latter is also hinged, outside **BB'**, a wrought iron  shaped piece **A**, which is rather larger than the other two. The arms **bb** of **BB'** are drilled to take shackle-bolts from which chains pass upward to the locking-gear; two holes are also drilled at **aa** for similar shackle-bolts and chains. The net-frame in its descent is suspended from **bb**, and is therefore tightly closed by its own weight (about 15 lbs.) and by any additional weight that may be hung on the axle, the arms pressing **BB'** firmly together; when the chains from **bb** are slacked by the locking-gear, the net falls for a short distance, the weight is caught on to the chains from **aa**, and the net-mouth either falls open, or opens on the slightest pull in towing. The whole apparatus is then hauled upwards through the zone which it is desired to investigate (generally 100 fathoms). The chains from **aa** are then slacked by the locking-gear, the net falls a second time, and the weight, being caught on the chains from **bb**, again closes the net effectively.

In fig. 2 the sectional dimensions of **A**, **B**, **B'** are given, the net-frame being represented as closed. The upper end of the net itself, laced inside the frame, is compressed into the space between **B** and **B'**; the dotted lines indicate the lacing-holes drilled through the frame at intervals of an inch. When it is closed, only a Protozoan could get through the net-mouth, and even that would find a difficulty.—**B** and **B'** when open form a mouth twenty inches square (inside measurement); **A** is $\frac{3}{4}$ inch outside them when closed. The arms **bb** are seven inches long, and effect a good leverage for closing the net. They form one of the most important improvements on the original pattern. Even shaking the frame violently up and down when held by the chains does not open the net.

[The **locking-gear** of the 1896 pattern was arranged as follows:—Through the chains from **aa** and **bb** were passed the hammers of two reversed gun-lock movements, the hammer rising when fired; the lock of the **bb** chains was placed vertically below that of the **aa** chains. Parallel to the vertical between these two ran a long steel rod, tapped with a screw-thread: at the lower end of the steel rod was a screw-propeller, arranged so as not to revolve during the descent of the apparatus. When hauled upwards, however, the propeller began to revolve, travelled up the steel rod,

and fired the trigger of the lower lock-movement, thus slackening the **bb** chains and allowing the net frame to fall open; still travelling upwards, as the apparatus was hauled in, the propeller presently fired the trigger of the upper lock-movement, slacked the **aa** chains, and the net then closed. The whole apparatus was prevented from spinning in its descent, and thus causing the propeller to begin travelling too soon, by being suspended from a swivel which worked on ball-bearings.

This arrangement worked successfully in about three hauls out of four, the failures being generally due to one or both chains hanging on the hammer, even when the lock-movement had been fired, owing to the great friction of the chains on the hammers. A further disadvantage in the apparatus was the difficult adjustment of the distance between the triggers, which determined the distance in fathoms for which the net remained open; this further had a tendency to vary somewhat with the rate of hauling in.]

In designing the **locking-gear** of the 1897 pattern I therefore abandoned the propeller in favour of messengers, which I had originally avoided on the grounds of others' experience with the light messengers of deep-sea thermometers. There seems, however, to be no objection to the use of *heavy* messengers on any well-stretched rope (hemp or wire) which hangs free of the bottom, and in which kinks are thus avoided by the maintenance of a steady strain.

Photographs of the whole apparatus are given on page 572. Details of the locking-gear are furnished by figs. 3 *a*, 3 *b* (p. 569), which are sectional drawings at right angles to one another. They are carefully drawn to scale, about one-seventh of the real size.

Four vertical pillars of teak¹ **T**, connected below by two cross-pieces of the same material **T'**, and strengthened by iron plates at the angles, form a rigid frame; on to this is screwed a brass casting **D**, to which a second casting **E** is screwed. The rope by which the machine is slung passes through a hole in the centre of **D** into the space **R** between **D** and **E**, and is kept there by being worked into a broad knot.

Two brass cylindrical rods or pins **FF** (fig. 3 *a*) run in two good bearings through **D** and are rigidly bolted into a cross-piece which carries a third shorter pin **a**, travelling in bearings through the centre of **E**. The pin **a** is passed through the chains from **aa** on the net-frame, and is kept in place by springs (not drawn) between the hooks shown in fig. 3 *a* with a pull of about 10 lbs. If a weight be dropped on to the pins **FF**, it will overcome the springs, depress the pin **a**, and let go the chains from **aa**.

A second pair of pins **GG** (fig. 3 *b*) run in bearings through **D**, and through another casting **H** which is bolted to **TT**. They are rigidly bolted to a cross-piece which carries a third pin **b**, travelling in bearings through the centre of **H**; this pin is passed through

¹ Teak is one of the few woods that will resist the enormous pressure at great depths; less closely-grained woods warp and split.

Fig. 6.

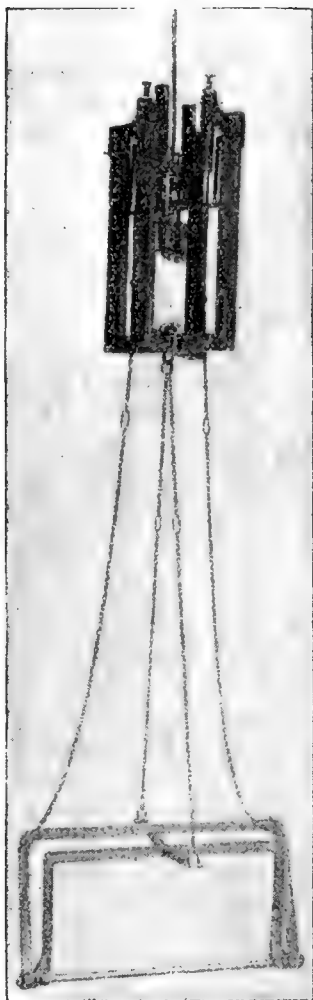

Fig. 5.

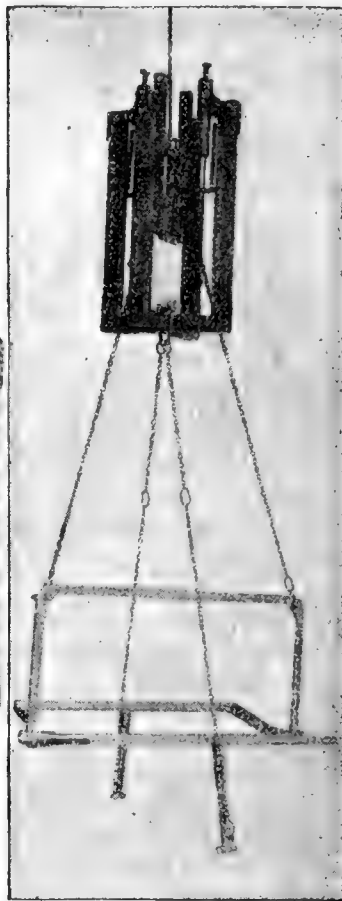
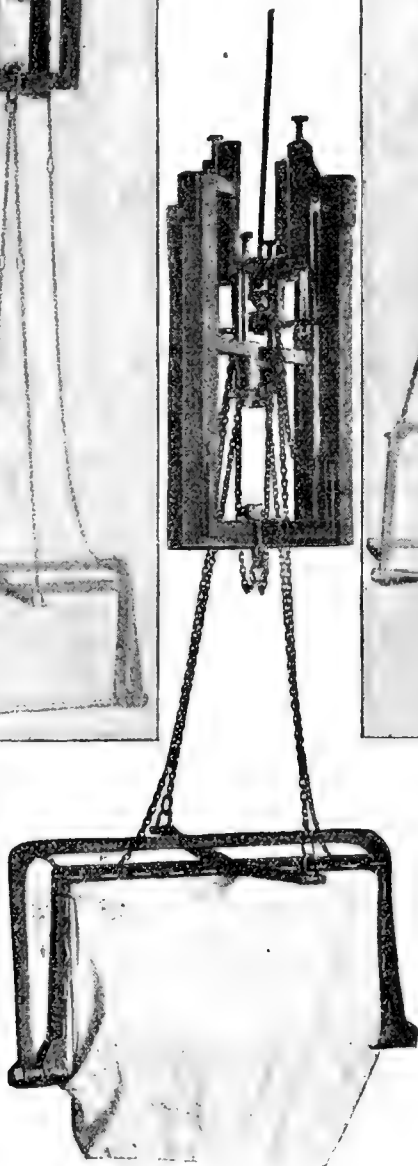

Fig. 4.



the chains from **bb** on the arms of the net-frame, and is kept in place by springs (rubber loops) between the hooks shown in fig. 3*b*, with a pull of about 10 lbs. If a weight be dropped on to the pins **GG**, it will overcome the springs, depress the the pin **b**, and let go the chains from **bb**.

The apparatus is worked thus:—The whole machine is lowered with the locking-gear in the position drawn in figure 4, the chains **aa** held on the pin **a**, but not carrying the weight of the net and frame; the chains **bb** held on the pin **b**, and holding the net-frame tightly closed by its own weight. When the machine is at the bottom of the zone which it is desired to study, the first messenger is despatched down the rope; this, being small, drops into the nest **N**, striking on the pins **GG**, and freeing the chains **bb**; the net-frame falls 6 inches, and opens, the weight being caught with a jerk on the chains **aa**.

The machine in this condition (fig. 5) is hauled upwards for a hundred fathoms; the second and larger messenger is despatched, which, striking on the pins **FF**, frees the chains **aa**; the net falls 15 inches, the weight is caught again on the chains **bb**; the net-frame closes, and can be then hauled in-board without any admixture with the fauna of higher zones (fig. 6).

The chains of course are not let go altogether, as the net and frame would then be lost; each chain has a large link in it to go over its pin, and beyond this a short length by which it is bolted to **T** or a shackle-bolt in the centre of **T'**.

	Chains aa .	Chains bb .
From net-frame to pin	33 in.	23 in.
From pin to T	9.5 in.
From pin to central bolt of T'	12 in.

The messengers used in 1897 were clumsy and unnecessarily heavy, and will not be described here. Probably weights of 4 lbs. for the smaller and 6 lbs for the larger are amply sufficient on rope: smaller weights would do on wire, since the friction is less.

The apparatus was tested in 1897 on H.M.S. 'Research,' but, unfortunately, owing to heavy weather, we were only able to spend one day in the deep water of the Faroe Channel; the apparatus was tried four times, and seemed to work perfectly. The only improvement which suggested itself was that a weight should be hung from the axle **C** into the middle of the net, heavy enough to prevent the net in its descent from washing up into the machinery (which happened once, but without serious consequences); the additional weight at this point will also serve to shut the net-mouth more closely, and can also be arranged to prevent the sides of the net compressing the contents when closed. Should the first messenger strike **FF** before **GG**, the net would simply come up empty, having been open only for a few seconds.

Weight of net-frame $16\frac{1}{2}$ lbs.; of locking-gear and chains 33 lbs.; of messengers used in 1897 ($7\frac{1}{2} + 10$) $17\frac{1}{2}$ lbs.; of messengers for

future use (4+6) 10 lbs.; suggested above to be added at T' T', 10 lbs., and to be hung on C, 10 lbs.: total about 80 lbs.

At the conclusion of the four hauls, the net was sent down to 100 fathoms, and hauled up without the messengers having been despatched; it came up empty, although it had passed through the stratum where life was probably most plentiful. I am unable to see any source of error in the working of this apparatus, but hope that it may be given a further trial before long¹. Of course, with an apparatus half a mile away from one in water, one cannot see what is actually occurring; one can only take precautions against every possible source of error, and may judge of their success to some extent by the character of the animals obtained.

Conclusions of Prof. Agassiz: the Azoic Zone.

In discussing the general results of the 'Albatross' Expedition in 1891², Prof. Agassiz reviewed the apparatus used and conclusions attained by earlier naturalists who had attempted a solution of the question of a Mesoplankton. His own views are based on experiments made during the cruises of the 'Blake' (1877-80) and the 'Albatross' (1891). On the first of these vessels he used the gravitating-trap³ invented by Lieutenant-Commander (now Captain) Sigsbee, which not only failed to catch living organisms between 100 and 150 fathoms, but apparently missed even the corpses of the dead surface fauna! The machine is only stated to have been tried on two occasions, and only to a depth of 150 fathoms; from this Agassiz concluded⁴ (p. 37) that "these experiments serve to prove that the pelagic fauna does not extend to considerable depths, and that there is at sea an immense intermediate belt in which no living animals are found, nothing but the dead bodies which are on their way to the bottom." On the 'Albatross' a new apparatus was tried, the invention of Captain Tanner, which is fully described and figured by Prof. Agassiz. On the basis of this he states⁴ (p. 55):—"Our experience in the Gulf of California with the Tanner self-closing net would seem to indicate that in a comparatively closed sea, at a small distance from the land, there may be a mixture of the surface species with the free-swimming deep sea bottom species, a condition of things which certainly does not exist at sea, in deep water, in an oceanic basin at a great distance from shore, where the surface pelagic fauna only

¹ The cost of the apparatus should come to about £10, now that the patterns for casting have been made. If any zoologist will give it a further trial, I shall be glad to superintend its manufacture.

Since the above was written, my net has been taken for a further trial by the German Expedition which sailed on August 1st under Prof. Chun's direction, and Prof. Max Weber has ordered a net for the Dutch East-Indian Expedition.

² Bull. Mus. Comp. Zool. Harvard, xxiii. 1.

³ Bull. Mus. Comp. Zool. Harvard, xiv. 36 (= 'Three Cruises of the Blake,' vol. i. p. 36, London, 1888, 8vo).

⁴ Bull. Mus. Comp. Zool. Harvard, xxiii. 1.

descends to a comparatively small depth, *i. e.* about 200 fathoms, the limits of the depth at which light and heat produce any considerable variation in the physical conditions of the water. The marked diminution in the number of species below 200 fathoms agrees fairly with the results of the 'National' Expedition."

The other experiments with the Tanner net, made in an oceanic basin on the way to Acapulco from the Galapagos, and to the Galapagos from Cape San Francisco, "seem to prove conclusively that in the open sea, even when close to the land, the surface pelagic fauna does not descend far beyond a depth of 200 fathoms, and that there is no intermediate pelagic fauna living between that depth and the bottom, and that even the free-swimming bottom-species do not rise to any great distance, as we found no trace of anything within 60 fathoms from the bottom, where it had been fairly populated."

Prof. Agassiz therefore admits the existence of a deep Mesoplankton near land, but does not state how far from land and in what depth of water his generalization of an Azoic zone begins to hold good. I do not know of any later pronouncement by this eminent oceanographer on the question. Since then, Captain Tanner has improved his original pattern in detail¹, but the principle of his net remains the same. It is rash, and perhaps a little ungracious, to criticize the working of a net which one has never seen; but I venture to suggest, on the basis of the drawings and description of the Tanner nets, that a weak point in them is the way in which the tripping lines are suspended; it seems that it would be so very easy for them to slip off from the tumbler and close the net before they were intended to do so, under the alternate strain and slackening of the warp as the ship rolls; it also seems likely, and indeed Captain Tanner himself admits, that the angle made sometimes by the net-frame in turning would practically close the net's mouth. As regards the Sigsbee gravitating trap, there can, I think, be little doubt that it was too small and too violent to throw much light on the question of an Azoic zone.

*Conclusions of the 'Challenger' and other Naturalists:
the Mesoplankton.*

Prof. Agassiz may be regarded as the chief representative of the school of naturalists which refuses to accept the alleged existence of a Mesoplankton. The chief supporters of the opposite view are the 'Challenger' naturalists (a distinguished band, of whom Sir John Murray is alone left), Prof. Chun, and Profs. Hensen and Brandt of the 'National' staff.

The 'Challenger' naturalists arrived at their belief from a comparison of serial tow-nets, stopped at intervals along the dredge-rope. As all the tow-nets were open throughout their course, the presence of particular species in the deep nets only seemed to indicate that these species occurred in the deep water only. The

¹ Z. L. Tanner, Bull. U.S. Fish Commission, xiv. p. 148.

method is theoretically excellent¹, but is not certain enough for use as an argument against the negative observations of the 'Blake' and 'Albatross.'

While I am fully in agreement with Professor Chun's results, it must be admitted that the original pattern of his net was not devoid of sources of error, which Agassiz was not slow to point out. Chun reported² an abundant fauna from all depths in the Mediterranean, but, this being a warm closed sea with a uniform temperature of 55° or 56° F. from 100 down to 2400 fathoms and more, no thermal barriers are here set to the vertical descent of an organism. It is not therefore possible to argue from this case to that of the great oceans, the temperature of which decreases with the depth until 30° F. or even less is reached.

Three hauls made by Prof. Chun on a voyage to the Canary Islands³ revealed a Mesoplankton at great depths, the general character of which agreed with the similar captures of the 'Challenger' and 'National.' The net used was an improvement on the Mediterranean pattern: open nets were also employed in other hauls.

As regards the 'National' net, a modification of Chun's pattern, Prof. Agassiz expressed suspicion of the locking arrangement which closed it. Prof. Brandt was kind enough to show it to me some years ago in Kiel; it is extremely ingenious in mechanism, but, as Prof. Hensen⁴ admits, it is most uncertain in its action; and, if I may judge from my own experience of a screw-propeller, it would not give very exact information of the depth; for the rate at which the propeller travels (*i. e.* the time-intervals from first hauling to opening, and from opening to shutting) varies so much with the rate of the steam-winch (an inconstant) and with the rolling of the ship. If there is any swell, the strain on the line as the ship rolls to leeward sends the propeller round at a greatly increased rate. While, however, venturing to criticize the method, I accept the positive results without any reserve, so far as they are published. They have been most recently summarized by Prof. Brandt⁵, and show a mesoplanktonic fauna which rapidly diminishes in numbers below 100 fathoms, together with a large number of dead organisms which are slowly settling to the bottom. Prof. Hensen⁶

¹ Though theoretically perfect and simple, this method of investigating Mesoplankton appears to me to present two practical objections to its use: the one, that such an enormous amount of material must be collected as will take years for its proper identification, before a comparison of surface and deep nets can be instituted; the other, that much of the deep material must inevitably be reduced to soup by pressure against the open tow-net in its long passage upwards; only forms with a strong skeleton (Radiolaria, Copepoda, &c.) can be expected to arrive fairly unbroken. In a closed net the resistance of the water does not appear to press the contents of the net against the meshes in the same way.

² C. Chun: Bibliotheca Zoologica, i.

³ C. Chun: Bibliotheca Zoologica, vii., and SB. Akad. Berlin, 1889, p. 519.

⁴ V. Hensen, *Ergebn. d. Plankton Expedition, Methodik der Untersuchungen*, p. 106.

⁵ K. Brandt: *Verh. Gesellsch. deutschen Naturforscher und Aertze für 1895, Lübeck*, p. 107.

⁶ V. Hensen: *Reisebeschreibung der Plankton Expedition*, p. 28.

maintains the accurate locking of his net as against Prof. Agassiz's criticism, and makes a very pregnant remark on the point:—"Das Netz ist aber nur das Mittel um beweisende Fänge möglichst rein zu erhalten, der wirkliche Beweis ist die Beschaffenheit des Fanges."

The above summary represents briefly the results and conclusions of the chief writers who have studied the question experimentally: in the case of Prof. Agassiz, negative results have led to the assertion of an Azoic zone; in the case of the 'Challenger,' the 'National,' and Prof. Chun, positive observations have led to the conclusion of the existence of a Mesoplankton, but in these cases the mechanism of locking the net has not been sufficiently certain to escape the criticisms of the opponent school. With their results the less extensive experiments of the Prince of Monaco ('l'Hirondelle'), the 'Pola,' and the 'Gazelle' are in general accord.

Results of the Cruises of the 'Research,' 1896 and 1897.

In commencing to work at this question, I attempted to construct a locking-gear with which not even Prof. Agassiz could find fault; with the view, firstly, of finally settling the question of the existence of a Mesoplankton, secondly, of endeavouring to ascertain definitely, in a small area and on a small scale, what animals habitually lived in, and what animals descended to, the mid-water strata (matters of very great importance from the standpoint of oceanic distribution).

I venture to submit that, as long as the Law of Gravity holds good, the absolute closure of my net is indisputable, for it is effected by gravity. It is not only certain in the actions of opening and shutting (gravity being here also the motive power), but, when shut, the net-frame closes so tightly that nothing larger than the net-mesh (1 mm. or .75 mm.) can get into it, either going down or coming up.

This being so, my observations agree on general lines with those of Chun and the 'National,' and directly contradict the purely negative observations of the 'Blake' and 'Albatross' on which Agassiz bases his theory of an Azoic zone. I encountered animals at every depth down to 500 fathoms, the deepest water available.

The Faeroe Channel was indicated as a suitable district by the thermal conditions; the depth is small when compared with the great oceans, but the extremely low temperatures met with in the district are those of the greatest depths in open oceans. As regards every thing but pressure, which appears to be an unimportant factor in determining distribution, the conditions of life at 500 fathoms in the "cold area" of the Faeroe Channel seem to be those of the greatest midwater depths known¹.

The Faeroe Channel is certainly a "closed sea" in the technical

¹ The Faeroe Channel was further indicated by the fact that H.M.S. 'Research' was surveying in the Orkney district. I cannot sufficiently express my obligations for the assistance rendered to me on so many sides—the recommendation of the Council of the Royal Society, the assent of the Lords Commissioners of the Admiralty, the suggestions of Admiral Sir William Wharton and Captain Tizard of the Hydrographic Office, and the uniformly patient help of Captain Moore and the other Officers of the 'Research' in both years.

sense of the word; but it is not a closed sea like the Mediterranean or Gulf of California, in which high temperatures are maintained to such a depth that there is practically no thermal limit to the descent of a surface organism. It is a closed sea on one side only, open to the Arctic Ocean on the North-east, with the isothermobath of 35° F. at about 250 fathoms, and in many places with a temperature of 30° F. at 500 fathoms. One is far from land nowhere in the Faeroe Channel; the single station of 1897 (Sta. 20) being only about a hundred miles from Cape Wrath, but far enough to be beyond the range of continental influence, in a case where the continental slope (100 to 500 fathoms) is steep, and no rivers discharge into the sea. The water at these depths is directly derived from the open Arctic ocean, and is practically unaffected by continental influence.

I would urge therefore, as against Prof. Agassiz, that planktonic animals can and do flourish at greater depths than 200 fathoms, even under oceanic and not neritic conditions: that they apparently flourish in utter darkness, at a temperature of 30° to 32° F., and at a depth of at least 500 to 400 fathoms.

The animals captured in the mid-water appear to fall into at least five categories:—(1) Organisms which range indifferently over all depths (eurybathic); of these, at any rate so far as the Faeroe Channel is concerned, *Calanus finmarchicus* may be taken as an example (p. 544 *ante*): (2) those which live habitually at great depths, and rarely or never appear at the surface, if at all, generally at night; of these characteristically mesoplanktonic animals, the Tuscarorida of the 'Challenger' Expedition, the deep-sea Schizopoda of Prof. Chun, *Sagitta whartoni* and *Conchæcia maxima* of the 'Research' collections¹ may be cited: (3) those which spend their earlier life at or near the surface, but of which adults are almost or quite confined to deep water, such as *Nyctiphanes norvegica*: (4) those which when adult inhabit the surface, but spend their larval life at considerable depths, such as Chun's Ctenophora: (5) the corpses of any of the foregoing classes, and of purely epiplanktonic animals, such as *Temora longicornis* (p. 546, table, *ante*).

With regard to this latter class, it will no doubt be urged by some naturalists that the capture of organisms in the Mesoplankton points, not necessarily to the fact of their living at great depths, but to their having been killed at the surface by unfavourable physical conditions and their subsequently sinking through the deeper strata towards the bottom. In many cases this is no doubt the true explanation of their presence in deep water; I have suggested this as the explanation of a particular haul of *Doliolum* (p. 583 *infra*), and of the presence of six species of Copepoda (pp. 548–9, *supra*) in the 'Research' collections from the Mesoplankton.

(1) In cases where numerous observations on successive days in the same district show numerous specimens of a species in the upper strata, but only a few specimens are rarely, not constantly, taken in the lower zones, this explanation probably holds good, especially in a Frontier district (p. 545) such as the Faeroe

¹ Proc. Zool. Soc. 1896, p. 992; 1897, p. 523.

Channel, where hotter and colder surface currents are constantly at war.

(2) This explanation may probably be further extended to cases such as those of the six Copepoda already mentioned (pp. 548-9); they appear to be southern (warm-water) forms, driven by the North Atlantic Drift into higher latitudes (colder temperatures) than they can bear. Although southern forms, none of them were taken at the surface in 17 hauls, five were captured once and one twice in 13 Mesoplankton hauls; all six were few in numbers.

(3) A different explanation seems reasonable in the case of species which are taken in numbers and with regularity at considerable depths, but appear rarely or never at the surface (if at all, then generally at night). It is to me inconceivable that the destruction of such a small surface population should produce dead specimens in such abundance and with such regularity in the deeper strata. *Euchaeta norvegica*, *Metridia longa*, and *Pleuromma abdo-minale* (pp. 543 and 547) are examples of this distribution; they seem to be forms which, at any rate in these latitudes, exhibit a preference for a mesoplanktonic existence, but which can and do exist at the surface also under certain circumstances. Two of the species are Arctic type-forms, which in these latitudes seek deeper (colder) water, and may perhaps eventually be taken very much further south as Mesoplankton than they have as yet been recorded in surface collections.

(4) When a species is taken in equal abundance and with equal regularity both in Mesoplankton and Epiplankton, it seems fair to infer that it is eurythermal and eurybathic; it does not seem possible that all the deeper specimens are deep merely because they are dead and sinking. For example, the list of the captures of *Calanus finmarchicus* on the 'Research' (p. 542) seems to exclude such a possibility.

It seemed worth while to cite these instances of criteria, which may be applied in dealing with collections of Plankton from various zones, if the observations are numerous enough and sufficiently near together in time and place to permit of any general conclusions at all being drawn. Most mesoplanktonic specimens are dead when they arrive inboard; the sudden alterations of pressure and temperature, and the damage by the net itself, are most fatal; further, decay is so retarded at low temperatures in sea-water, that not even microscopical examination can be relied on as evidence of the life or death of the organism at the moment of capture. The criteria applied above may be expressed thus:—

Specimens at surface	Specimens below	Species belongs to
Numerous, constant.	None, or occasionally a few.	Epiplankton.
Numerous, constant.	Numerous, constant.	Epiplankton and Mesoplankton.
None, or occasionally a few.	Numerous, constant.	Mesoplankton.

The table on pp. 542-3 showing the vertical distribution of the 'Research' Copepoda in the Faeroe Channel, seems to me to offer convincing proof of the existence of a living Mesoplankton. If the forms which I caught at great depths were all dead, there would be more dead species in the district than live ones, which seems absurd; the average number of species per haul is .88 in the Epiplankton and 1.38 in the Mesoplankton. Further, the deep water would contain an abundance of dead specimens of a species, such as *Euchaeta norvegica*, of which there were practically no specimens at the surface to be killed; which also seems absurd. Again, if the destruction at the surface is so extensive as the death-hypothesis would imply, some specimens at least of *Temora longicornis*, and of all such forms as are abundant at the surface, ought to be captured in the lower strata; yet this species was not once taken in the Mesoplankton.

In concluding this discussion of the general question, I would strongly urge that any attempt, seriously to investigate the Mesoplankton in future, should be made, not at random stations all over the ocean, but in a limited area, one which presents as far as possible uniform conditions throughout, and may be presumed to contain a similar fauna throughout; for only by *numerous successive hauls at all depths* can that careful comparison be made, which will enable the observer to assign to each organism the proper significance of its occurrences.

DOLIOLUM (DOLIOLETTA Borgert¹) TRITONIS, Herdm.
= *D. denticulatum* Herdman².

This species presented no new anatomical features for record. As Herdman points out², some specimens are cylindrical rather than of the characteristic barrel-shape; he assigns this to imperfect preservation. A comparison of my specimens from different stations with specimens of other animals from those stations, leads me to believe that the alteration in shape is due to damage in the tow-net by pressure. The smallest sexual specimens which still carried the stalk of attachment to the "Pflegethier" were about 5 mm.; it had been lost in one of 7 mm. length.

The horizontal distribution of this species was enormously extended by the 'National' (Plankton Expedition); till 1889 it had, I believe, only been taken in the Faeroe Channel, the North Sea, and off the Hebrides; the 'National' captured it in that year over nearly the whole of their course, from the Labrador Current right down to the South Equatorial Drift.

The appearance of huge swarms of sexual forms of *D. tritonis*

¹ A. Borgert: Thaliacea der Plankton Expedition.—C. Vertheilung der Doliolen. 1894.

² W. A. Herdman: Trans. Roy. Soc. Edinburgh, xxxii. p. 101.

in the Faeroe Channel is very perplexing. On the second and last days out of eight in 1896, they were at or near the surface in enormous quantities (96 to 140 specimens in a haul of 10 to 15 minutes); on the other six days, they were not only scarce or absent at the surface, but could not be found even by the deep-water net. Our position was altered several times between the two days of their swarming. This seems to imply that *D. tritonis* occurs in patches, with a few outliers in between the patches. Similar swarms of this species were observed in the Faeroe Channel by the 'Triton' in 1882¹, by the 'Holsatia' in 1885, by the 'National' in 1889.

Brandt², in an interesting discussion of swarms such as these, seems to incline to the view that they are produced by wind and current action; but it is a little difficult to imagine how the effect of these agents would gather scattered organisms into a broad swarm in the open sea, except in an eddy or backwater; although they might make "wind-rows" in the open sea, or swarms in a closed area such as the Mediterranean. Further, if wind and current were the main direct agents in collecting swarms of *D. tritonis*, other organisms of the same powers of locomotion ought also to swarm at the same time; this is not my experience, nor, so far as I know, have other observers recorded this as a feature of the case.

I should prefer for the present to regard a swarm of *D. tritonis* mainly as the result of a period of great reproductive activity. In the case of an organism with a rapid power of multiplication and definite reproductive periods (whether due to food, temperature, or other causes), a very large number of individuals will soon be produced nearly simultaneously; if they have but little power of self-locomotion, as long as they lie in the track of fairly uniform wind and current, such as the North Atlantic Drift ("Gulf Stream"), there seems to be no reason why they should be parted one from another. In an eddy, such as the Sargasso Sea, where there are no constant winds or constant currents, the tendency will probably be for every little shift of wind to part them. The swarms of various organisms met by the 'National' were apparently all in the track of great ocean-currents, and were conspicuously absent from the Sargasso Sea.

If my suggestion is correct, then in still or steadily moving water a few *Doliolum* "Ammen," fairly close together, will produce a crop of "Pflegethiere" by asexual generation more numerous than themselves; and although we do not know the rate of reproduction of the "Amme" in throwing off "Pflegethiere," still that each "Pflegethier" may throw off an enormous number of sexual forms is obvious from the hundreds of buds on the stolon of each *Pflegethier*. The rate of reproduction is extremely rapid; and I see no reason to believe that in a constant current the family would not move forwards as a whole.

¹ "At times the *Doliolum* appeared to be in vast banks, where they were very numerous; between these banks there were always a few stragglers." (Murray in Herdman, *op. cit.* p. 112.)

² Brandt: in *Reisebeschreibung der Plankton Expedition*, p. 356 (1892).

It would appear also that the reproduction (throwing off) of sexual forms is *periodic*, from the following facts:—

The 'Research' specimens consisted of very numerous fully-grown sexual forms, a few much smaller sexual forms, and a few large 'Pflegethiere.' Other observers¹ have recorded much the same for the same time of year (July, August).

Taking this in conjunction with the fact that, in my collections at any rate, sexual specimens of intermediate size, between the less than 5 mm. and the more than 9 mm. specimens, were very scarce, it would appear that the swarms were due to a period of simultaneous throwing off of numerous sexual forms; their existence and growth being, naturally, only possible when, as Borgert suggests, the conditions of food, temperature, &c. are favourable.

The above remarks apply to the 'Research' collections of 1896. In 1897 we were able to collect on one day only. On this occasion *Doliolum* was rare at the surface (like everything else), and the bulk of the catch was at a considerable depth. The small specimens were, proportionately to the large, very much more numerous at the surface than in the collections of 1896; the larger forms seemed to have sunk, like almost everything else, under the influence of very cold and somewhat boisterous weather. The following table gives the numbers taken:—

Sta.	Haul in fathoms.	Temperature.	Specimens.
20 e.	0		16 large ² , 4 small
20 f.	0		4 " 0 "
20 g.	40 to 0		1 " 25 "
20 a.	200 to 100		0 " 0 "
20 b.	300 to 200		11 " 0 "
20 c.	400 to 300		3 " 0 "
20 d.	500 to 400		130 " 9 "

As they were almost absent from the Mesoplankton during the 1896 cruise, I should not like to suggest, without more extended observations, that the deeper specimens were at so great a depth and so low a temperature, of their own free will. It seems to me probable, although there was nothing in their appearance either to suggest or to contradict it, that, in the haul 20 d, the net struck a swarm which had been killed by cold or other unfavourable circumstances, and was slowly settling to the bottom. The only differences between the specimens from 20 c and 20 d, and those surface-specimens which were living when brought on board, was that the digestive coil was blue in the deep-water specimens, brown or reddish in the surface specimens. Experiment would easily determine whether this was a post-mortem change or not.

¹ "Such vast numbers.... with a very few exceptions of much the same size" (no *Pflegethiere* noticed); Herdman, *op. cit.* p. 111. — "Erst bei genauerer Durchsicht fand ich unter ihnen, wenn gleich in weitaus geringerer Zahl, *Pflegethiere* und auch *Ammen*"; Borgert, *op. cit.* p. 61. "*Ammen*" were not observed among the 'Research' specimens.

² Three were "*Pflegethiere*."

ON THE OCCURRENCE OF *Doliolum nationalis* (Borgert) IN
BRITISH WATERS.

By the courtesy of Mr. E. T. Browne and of Mr. E. J. Allen, the Director of the Plymouth Laboratory, I have been able to examine specimens of the alleged *Doliolum tritonis* from Valentia and Plymouth. These southern specimens prove to be *D. nationalis* Borgert¹; they differ from *D. tritonis* not only in their much smaller size, but in the point of origin and attachment of the branchial lamella. A further difference between the species, not discussed by Borgert, is shown by the relations of the intestine: in *D. tritonis* (correctly figured by Herdman²) this is short, thick, and sharply curved on itself; in *D. nationalis* (correctly figured by Borgert, pl. v. fig. 4) it is long and slender, and, after a nearly straight course posteriorly, it is only slightly curved forwards, often not so much so as he has figured.

D. nationalis appears to be a southern and warm-water form. It has only been described hitherto from the collections of the 'National' (German Plaukton Expedition) in 1889: it was absent until the 'National' struck the true Gulf Stream (37° N. 59° W., surface temperature 79° Fahr.); from there it occurred with greater or less regularity through the Sargasso Sea, North Equatorial, Counter Equatorial ("Guinea Current"), and South Equatorial Drifts, right up to the mouth of the English Channel (49° 7' N., 5° 8' W., surface temperature 52° Fahr.), where one specimen only was captured. It appears to be only an occasional visitor to our shores, probably under the influence of prevalent south-westerly winds and warm weather; it occurred at Plymouth and Valentia in 1893³ and 1895⁴.

PARATHEMISTO ABYSSORUM (Boeck).

This species according to Hansen⁵ and Sars⁶ is probably identical with *Hyperia obliuia* Krøyer; a view now accepted by Bovallius⁷. *H. obliuia* Spence Bate, appears to be not identical with either of the above.

Its distribution vertically and horizontally is a little perplexing, so far as our information goes at present.

i. It lives in cold water, apparently at the surface, in Greenland seas (Krøyer⁸ and Hansen⁵), and in the Murmanske Hav, North of Russian Lapland (Hansen⁹).

ii. It lives in cold water at great depths—from 1710 to 160

¹ *Op. cit.* p. 581 *supra*.

² *Op. cit.* p. 581 *supra*, pl. xx. fig. 1.

³ W. Garstang: Journ. Mar. Biol. Assoc. iii. p. 222. See also p. 210 for an account of the weather that year.

⁴ E. T. Browne: Journ. Mar. Biol. Assoc. iv. p. 171.

⁵ Hansen: Malacostraca marina Grœnlandiæ occidentalis.

⁶ G. O. Sars: Crustacea of Norway, vol. i. p. 11.

⁷ Bovallius: Kongl. Svenska Vetenskaps-Akad. Hdlg. xxi. p. 251.

⁸ Krøyer: "Grönlands Amphipoder," Vidensk. Selsk., nat.-math. Afh. vii. p. 229.

⁹ Hansen: Dijnphna Togtets zool.-bot. Udbytte, 1886, Krebsdyr, p. 28.

fathoms at 6 stations of the Norske Nordhavs Expedition¹; all along the West Coast of Norway up to Finmark from 100 to 200 fathoms (Sars²); in the cold area of the Faeroe Channel (H.M.S. 'Research,' 1896, 530 to 220 fath.).

iii. It appears to come up to the surface from great depths at night, in the Faeroe Channel (H.M.S. 'Research,' 1896, Station 15 *d*); it has been taken off the Shetlands³, and in the Faeroe Channel by the 'Triton' in 1882.

iv. It has been recorded from shallow waters round our coasts: from Banff (Edwards⁴); from the Forth⁵; once, a single specimen, from the Clyde (Robertson)⁶; off St. Andrews (McIntosh); from Valentia, where what appeared to be very young specimens of this species were taken in profusion by Messrs. A. O. Walker and E. T. Browne. Mr. Walker also informs me that he has received specimens 5 mm. in length from off Galley Head, co. Cork.

Now the curious fact about the specimens from Valentia, Galley Head, and the Firth of Forth is that they are all very small, ranging from 2 to 5 mm.; whereas in the Faeroe Channel they are mostly about 7–10 mm. in length, and specimens from the Norwegian North Atlantic Expedition reached the length of 17 mm. The length of the Banff specimens is not given. In all probability the small size of the British specimens of this sub-Arctic form indicates either (1) that the species attains a smaller size under increased temperature; or (2) that the larger adults are oceanic, and come inshore to breed, dying or retreating again to the open sea afterwards (this is Mr. Walker's suggestion); or (3) that the small and apparently young specimens of our coasts normally live in the open sea but nearer the surface than the adults, and are only driven on to our shores in heavy weather, or by a southerly current.

I have nothing to adduce either for or against the first suggestion. Against Mr. Walker's suggestion, it may be urged that the adult forms have not been recorded from inshore waters, and would surely have been noticed if they arrived in great numbers to breed. For, one feature of the appearance of this species on our coasts is that it generally arrives in enormous numbers (Firth of Forth, Banff, Valentia in 1896; they were less numerous, but plentiful at Valentia in 1897): this would imply the presence at some time of numerous parents, which have never been recorded.

The third suggestion appears to me to be likely to prove the correct solution; namely, that both young and adults normally inhabit open water, the young living nearer the surface and being brought to our shores as occasional visitors under special circumstances of weather and current. The clue is to be found in an

¹ G. O. Sars: Norske Nordhavs Expedition, Crustacea, vol. ii. p. 37.

² G. O. Sars: Crustacea of Norway, vol. i. p. 11.

³ A. M. Norman: Rep. British Association for 1868, p. 287.

⁴ Edwards: Journ. Linn. Soc. ix. p. 166.

⁵ Sir John Murray kindly sent me a sample of these.

⁶ Robertson: Trans. N. H. Soc. Glasgow, n. s. ii. p. 69 (1890).

observation of Sars¹:—"A much smaller form, scarcely exceeding 5 mm. in length, but otherwise wholly agreeing with the typical species, I have met with in less depth [than 100 fathoms] and occasionally even near the surface of the sea." Edwards, in the paper already cited, speaks of their being "cast on shore during gales from the North in most enormous and incalculable numbers," and of "a ridge or wall of these animals extending more than a hundred feet in length, and varying from 1 to 2 inches in height and breadth, which had been washed up by the sea." He evidently considered them to live normally out at sea, and to come inshore occasionally "in search of food perhaps."

There are of course other forms, such as *Nyctiphanes norvegica*, which are known to inhabit the upper strata when young, and to descend normally to greater depths when adult. Other forms again are known to appear in the North Sea only at times when a strong set of southerly current brings down an Arctic or sub-Arctic Fauna².

I have discussed the distribution of this form at some length because it seems to me to illustrate our utter ignorance of the normal habitat and occasional appearance of some "British" species,—conditions which are fundamental factors in the distribution and bionomics of marine organisms, and which can only be elucidated by patient observation and *detailed records* all round the coast-line.

Parathemisto abyssorum may be fairly regarded as a member of the Mesoplankton in the Faeroe Channel: it occurred in seven out of thirteen deep-water hauls; and in one out of three hauls which began at or over 300 fathoms and finished at the surface; it occurred in only one out of twenty-five hauls between 100 and 0 fathoms, and then at midnight and very abundantly (15*d*). It is also apparently a cold-water form by preference, as it did not occur in either of the deep hauls in the "warm area" (19*a*, 480 to 350 fms.; 19*b*, 480 to 0 fathoms).

¹ G. O. Sars: Crustacea of Norway, vol. i. p. 11.

² C. Chun: Beziehungen zwischen den arktischen und antarktischen Plankton. Stuttgart, 1897, 8vo.

CONTENTS (*continued*).

June 21, 1898 (*continued*).

	Page
Mr. Boulenger. Notice of a Memoir on the Fishes collected by Mr. J. E. S. Moore in Lake Tanganyika	494
1. On the Scorpions, Spiders, and Solpugas collected by Mr. C. Stuart Betton in British East Africa. By R. I. Pocock, of the British Museum of Natural History. (Plates XLL & XLIII)	497
2. On the Fungid Corals collected by the Author in the South Pacific. By J. STANLEY GARDINER, M.A., Gonville and Caius College, Cambridge. (Plates XLIII.—XLV.)	525
3. Description d'un Genre nouveau d'Ophidiens, <i>Geotractus</i> . Par ALFRED DUGÈS, M.D. ..	539
4. Contributions to our Knowledge of the Plankton of the Faeroe Channel.—No. IV. Report on the Copepoda collected by Dr. G. H. Fowler from H.M.S. 'Research' in the Faeroe Channel in 1896 and 1897. By ISAAC C. THOMPSON, F.L.S. (With an Appendix by Dr. FOWLER.)	540
5. Contributions to our Knowledge of the Plankton of the Faeroe Channel.—No. V. Report on a Collection of very young Fishes obtained by Dr. G. H. Fowler in the Faeroe Channel. By ERNEST W. L. HOLT. (Plates XLVI. & XLVII.)	550
6. Contributions to our Knowledge of the Plankton of the Faeroe Channel.—No. VI. Description of a new Mid-water Tow-net. Discussion of the Mid-water Fauna (Mesoplankton). Notes on <i>Doliolum tritonis</i> and <i>D. nationalis</i> , and on <i>Parathemisto abyssorum</i> . By G. HERBERT FOWLER, B.A., Ph.D., Assistant Professor of Zoology, University College, London	567

LIST OF PLATES.

1898.

PART III.

Plate		Page
XXVIII.	<i>Petrophassa rufipennis</i>	} 353
XXIX.	<i>Ptilopus (Leucotreron) alligator</i>	
XXX.	Insects from Socotra	} 372
XXXI.	Araneidea from Socotra	
XXXII.	} British-East-African Lepidoptera	} 395
XXXIII.		
XXXIV.	} <i>Aethurus glirinus</i>	} 450
XXXV.		
XXXVI.	<i>Macrura anomala</i> from the South Pacific	457
XXXVII.	<i>Gephyrea</i> from Rotuma and Funafuti.....	468
XXXVIII.	1. <i>Phrynobatrachus perpalmatus</i> . 2. <i>Arthroleptis moorii</i> . 3. <i>Phryniculus oxyrhinus</i> . 4. <i>Mantophryne robusta</i> ..	} 473
XXXIX.	1. <i>Hylodes alfredi</i> . 2. <i>Borborocates mexicanus</i> . 3. <i>Hyla</i> <i>microcephala</i> . 4. <i>Hyla fallax</i>	
XL.	<i>Molge italica</i>	482
XLI.	} British-East-African Arachnida	} 497
XLII.		
XLIII.	} Corals from the South Pacific	} 525
XLIV.		
XLV.		
XLVI.	} Plankton of the Faerøe Channel	} 550
XLVII.		

NOTICE.

The 'Proceedings' are issued in four parts, as follows:—

- | | | |
|------|------|--|
| Part | I. | containing papers read in January and February, on June 1st. |
| | II. | " " " " March and April, on August 1st. |
| | III. | " " " " May and June, on October 1st. |
| | IV. | " " " " November and December, on April 1st. |

PROCEEDINGS
OF THE
GENERAL MEETINGS FOR SCIENTIFIC BUSINESS
OF THE
ZOOLOGICAL SOCIETY
OF LONDON
FOR THE YEAR
1898.

PART IV.
CONTAINING PAPERS READ IN
NOVEMBER AND DECEMBER.

APRIL 1st, 1899.

PRINTED FOR THE SOCIETY,
SOLD AT THEIR HOUSE IN HANOVER SQUARE.

LONDON:
MESSRS. LONGMANS, GREEN, AND CO.,
PATERNOSTER-ROW.

[*Price Twelve Shillings.*]

LIST OF CONTENTS.

PART IV.—1898.

November 15, 1898.

	Page
The Secretary. Reports on the Additions to the Society's Menagerie in June, July, August, September, and October 1898. (Plate XLVIII.)	585
Mr. Sclater. Exhibition of, and remarks upon, a photograph of Grévy's Zebra (<i>Equus grevii</i>).	588
Mr. Sclater. Exhibition of a set of photographs of the Bangkok Museum, Siam	588
Dr. S. W. Bushell. Extract from a letter from, on the herd of <i>Cervus davidianus</i> in the Imperial Hunting Park, Peking	588
Prof. G. B. Howes. Exhibition of, and remarks upon, series of embryos and living eggs of the Tuatera (<i>Sphenodon punctatus</i>).	589
Messrs. E. W. L. Holt and L. W. Byrne, F.Z.S. Exhibition of, and remarks upon, specimens and drawings of a supposed new Sucker-fish (<i>Lepadogaster stictopteryx</i>)	589
1. A Revision of the Moths of the Subfamily <i>Pyraustinae</i> and Family <i>Pyralidae</i> . By Sir G. F. HAMPSON, Bart., F.Z.S., &c.—Part I. (Plates XLIX. & L.)	590
2. List of the Mammals obtained by Mr. R. McD. Hawker during his recent Expedition to Somaliland. By W. E. DE WINTON, F.Z.S.	761
3. On Mammals collected by Mr. J. D. La Touche at Kuatun, N.W. Fokien, China. By OLDFIELD THOMAS, F.Z.S.	769
4. A Revision of the Genera and Species of Fishes of the Family <i>Mormyridae</i> . By G. A. BOULENGER, F.R.S. (Plate LI.)	775
5. A List of Butterflies obtained in the Harar Highlands by Capt. H. G. C. Swayne, R.E. By ARTHUR G. BUTLER, Ph.D., F.L.S., F.Z.S., &c.	821
6. On a small Collection of Butterflies made in the Chikala District, British Central Africa, by Mr. George Hoare. By ARTHUR G. BUTLER, Ph.D., F.L.S., F.Z.S., &c.	823
7. On a small Collection of Butterflies from British East Africa, obtained at the end of 1897 and beginning of 1898 by Mr. R. Crawshaw. By ARTHUR G. BUTLER, Ph.D., F.L.S., F.Z.S., &c.	825
8. Notes on the Collection of Specimens of the Genus <i>Millepora</i> obtained by Mr. J. Stanley Gardiner at Funafuti and Rotuma. By Professor SYDNEY J. HICKSON, M.A., F.R.S., F.Z.S.	828
9. Report on the Holothurians collected by Mr. J. Stanley Gardiner at Funafuti and Rotuma. By F. P. BEDFORD, B.A., King's College, Cambridge. (Plates LII. & LIII.)	834
10. On the Actinogonidiate Echinoderms collected by Mr. J. Stanley Gardiner at Funafuti and Rotuma. By F. JEFFREY BELL, M.A., F.Z.S.	849
11. On a new Antelope of the Genus <i>Hippotragus</i> . By OSCAR NEUMANN	850

November 29, 1898.

Mr. P. Chalmers Mitchell, F.Z.S. Exhibition of, and remarks upon, some etched studies of young Orang-Outangs	851
Mr. G. A. Boulenger. Exhibition of, and remarks upon, a dancing-stick from New Guinea to which two skulls of the Chelonian <i>Carettochelys insculpta</i> were attached	851

Contents continued on page 3 of Wrapper.

observation of Sars¹:—"A much smaller form, scarcely exceeding 5 mm. in length, but otherwise wholly agreeing with the typical species, I have met with in less depth [than 100 fathoms] and occasionally even near the surface of the sea." Edwards, in the paper already cited, speaks of their being "cast on shore during gales from the North in most enormous and incalculable numbers," and of "a ridge or wall of these animals extending more than a hundred feet in length, and varying from 1 to 2 inches in height and breadth, which had been washed up by the sea." He evidently considered them to live normally out at sea, and to come inshore occasionally "in search of food perhaps."

There are of course other forms, such as *Nyctiphanes norvegica*, which are known to inhabit the upper strata when young, and to descend normally to greater depths when adult. Other forms again are known to appear in the North Sea only at times when a strong set of southerly current brings down an Arctic or sub-Arctic Fauna².

I have discussed the distribution of this form at some length because it seems to me to illustrate our utter ignorance of the normal habitat and occasional appearance of some "British" species,—conditions which are fundamental factors in the distribution and bionomics of marine organisms, and which can only be elucidated by patient observation and *detailed records* all round the coast-line.

Parathemisto abyssorum may be fairly regarded as a member of the Mesoplankton in the Faeroe Channel: it occurred in seven out of thirteen deep-water hauls; and in one out of three hauls which began at or over 300 fathoms and finished at the surface; it occurred in only one out of twenty-five hauls between 100 and 0 fathoms, and then at midnight and very abundantly (15 *d*). It is also apparently a cold-water form by preference, as it did not occur in either of the deep hauls in the "warm area" (19 *a*, 480 to 350 fms.; 19 *b*, 480 to 0 fathoms).

November 15, 1898.

W. T. BLANFORD, Esq., F.R.S., V.P., in the Chair.

The Secretary read the following reports on the additions made to the Society's Menagerie during the months of June, July, August, September, and October, 1898:—

The total number of registered additions to the Society's Menagerie during the month of June was 147, of which 60 were by presentation, 16 by birth, 36 by purchase, 2 were received in exchange and 33 on deposit. The total number of departures during the same period, by death and removals, was 109.

¹ G. O. Sars: Crustacea of Norway, vol. i. p. 11.

² C. Chun: Beziehungen zwischen den arktischen und antarktischen Plankton. Stuttgart, 1897, 8vo.

Amongst these may be specially noticed :—

1. Two examples of Forster's Lung-Fish (*Ceratodus forsteri*) from Queensland, purchased of Mr. D. O'Connor, who has successfully conveyed from Australia to England four fine living specimens of this remarkable Dipnoan, believed to be the first ever brought to Europe alive.

2. A young pair of White-tailed Gnus (*Connochaetes gnu*), presented by Mr. C. D. Rudd, F.Z.S., who kindly brought them from his park at Fernwood, Newlands, near Cape Town, in order to make a change of blood in the small herd of these Gnus in the Society's Gardens.

The total number of registered additions to the Society's Menagerie during the month of July was 273, of which 46 were by presentation, 12 by birth, 62 by purchase, and 153 were received on deposit. The total number of departures during the same period, by death and removals, was 116.

Amongst these may be specially noticed :—

1. A young male Lesser Koodoo (*Strepsiceros imberbis*) from Somaliland, purchased July 1st.

So far as we know this is the third specimen of this beautiful Antelope that has reached Europe alive. Two former ones were received by the Society in 1886 and 1889 (see 'List of Animals,' 1896, p. 160).

2. A pair of Jackals, obtained on the same occasion, which are new to the Society's collection, and appear to be referable to the species distinguished by Dr. Noack (Zool. Gart. xxvii. p. 234, 1886) as *Canis hagenbecki*. They seem to belong to the group of *Canis mesomelas*, but are immediately distinguishable by their large elongated ears and long limbs.

3. A female example of an apparently new African Monkey of the genus *Cercopithecus*, received from Congoland by the Zoological Society of Antwerp, and obtained from that Society in exchange on July 2nd.

This Monkey appears to belong to "section d. *Melanochiri*" of the arrangement proposed by me, P. Z. S. 1893, p. 250, and may perhaps come nearer *C. albogularis* than to any other species, but it is immediately distinguishable by its dark head and the large fluffy white elongated ruff on each side of the throat. It may be provisionally named *Cercopithecus l'hoesti* after Mons. L'hoest, the distinguished Director of the Jardin Zoologique d'Anvers, and characterized as follows :—

CERCOPITHECUS L'HOESTI, sp. nov. (Plate XLVIII.)

Above, back ferruginous brown with narrow transverse lines of black; head black with slight whitish freckles; sides of face and neck covered with elongated ruff-like hairs, white; throat white; belly cinereous; all four limbs dark cinereous, blackish on the outsides; tail cinereous, above blackish. Size of *C. albogularis*,

Hab. Congoland.



J. Smit del. et lith.

Mintern. Bros. imp.

CERCOPITHECUS L'HOESTI, ♀.



4. A young male Giraffe belonging to the Northern form (*Giraffa camelopardalis typica*), purchased of Mr. Hagenbeck on July 6th. This animal, which appears to be about a year old, was captured in Senegal and brought home from Dakar by one of Mr. Hagenbeck's agents. I exhibit some photographs of it. After living in apparently fairly good health in the Gardens until August 8th, it died rather suddenly, and upon examination was found to be suffering from hydatid tumours.

5. A gigantic Centipede (*Scolopendra gigas*) from Trinidad, presented by Mr. R. R. Mole, C.M.Z.S., July 7th. This specimen, though perhaps not full-grown, is nearly eight inches long, and feeds well on small mice.

6. A series of fifty-two large Tortoises from the Galapagos Islands, deposited by the Hon. Walter Rothschild on July 20th. Nineteen of these, from Duncan Island, appear to be referable to *Testudo ephippium*, and thirty-three, from Albemarle Island, to *Testudo vicina*.

The total number of registered additions to the Society's Menagerie during the month of August was 241, of which 129 were by presentation, 3 by exchange, 29 by purchase, 69 were received on deposit, and 11 were born in the Gardens. The total number of departures during the same period, by death and removals, was 128.

Amongst these may be specially noticed :—

1. A very fine and large specimen of the Reticulated Python (*Python reticulatus*), deposited by the Hon. Walter Rothschild, F.Z.S., August 26th. This Python (which is about 23 feet in length) exceeds in size the specimen which lived for 20 years in the Society's Gardens.

2. Twelve African Walking-Fish (*Periophthalmus koelreuteri*), presented by Dr. H. O. Forbes, F.Z.S., August 26th.

The registered additions to the Society's Menagerie during the month of September were 100 in number. Of these 39 were acquired by presentation, 5 by purchase, 7 were born in the Gardens, and 49 were received on deposit. The total number of departures during the same period, by death and removals, was 157.

Amongst these may be specially noticed :—

1. A fine specimen of Rüppell's Colobus (*Colobus guereza*) from Nigeria, presented by Mr. Justice Kelly, September 2nd. The donor informs us that this specimen was formerly in the possession of the Emir of Yola and that the species is known in Nigeria as the "Maclam," the name given to a Mohammedan priest in the Hausa language.

This specimen may possibly be referable to *Guereza occidentalis*, Rochebrune (Faune Sénégal., Suppl. i. p. 141, pl. xiii.), but, so far as I can tell while it is alive, is only subspecifically distinct from *C. guereza*.

2. A fine male example of the Duke of Bedford's Deer (*Cervus xanthopygius*), from China, presented by H.G. The Duke of Bedford, Sept. 2nd.

The total number of registered additions to the Society's Menagerie during the month of October was 68, of which 42 were acquired by presentation, 6 by birth, 10 by purchase, and 10 were received on deposit. The total number of departures during the same period, by death and removals, was 89.

Amongst these may be specially noticed :—

A young male Siamang (*Hylobates syndactylus*) from Negri Sembilan, Malay Peninsula, presented by Mr. Stanley S. Flower, F.Z.S., October 17th, being the first individual of this extremely interesting Anthropoid Ape that has reached us in a living state.

It will be recollected that the late Dr. George Bennett, F.Z.S., obtained an example of the Siamang at Singapore in 1830, and intended to bring it to England for the Society, but it unfortunately died on its way home (see Bennett's 'Wanderings in New South Wales,' ii. p. 142, 1834).

Mr. Sclater exhibited and made remarks upon a photograph of the specimen of Grévy's Zebra (*Equus grevii*) lately sent by the Emperor Menelek of Abyssinia as a present to the President of the French Republic, and deposited by the latter in the Jardin Zoologique d'Acclimatation in the Bois de Boulogne. The animal was said to stand about 5 ft. 11 in. in height to the top of its ears, and about 5 ft. at the withers. This was the second living specimen of this Zebra yet brought to Europe (see P. Z. S. 1882, p. 721).

Mr. Sclater stated that he had been for some time endeavouring to obtain living examples of this Zebra for the Gardens from correspondents in Shoa and Somaliland.

Mr. Sclater exhibited a set of five photographs of the Royal Siamese Museum, Wang Na, Bangkok, which had been presented to him by Mr. Stanley S. Flower, F.Z.S. Mr. Flower had now left his post as Director of the Museum at Bangkok, and taken up that of Director of the Zoological Garden at Gizeh, near Cairo. On his way home he had brought with him the living Siamang, the safe receipt of which had been already mentioned in the Secretary's report.

The following extract from a letter from Dr. S. W. Bushell, C.M.Z.S., to Mr. Sclater, dated July 14, 1898, was read :—

"I am well acquainted with the habits of the *Cervus (Elaphurus) davidianus*, and used often to ride among the herds which formerly swarmed in the Non Hai-tzū, the Imperial Hunting Park south of Peking, which is enclosed by a wall forty-five miles in circuit. But four years ago the brick wall was breached in many places by the waters of the Hun Ho, as they flooded the adjoining country,

and the deer escaped, to be devoured by the famine-stricken peasantry. I fear that none are left; but will make further inquiry when I return to my post next year. It is strange that none have been found wild in Kashgaria, which is said by a Chinese author of the early part of the last century to be the native country of this peculiar deer, which they call the 'Ssū pū hsiang,' or 'Four unlikes.'"

Prof. G. B. Howes exhibited a series of embryos and 5 living eggs of the Tuatera, *Sphenodon punctatus*, which he had received from Prof. A. Dendy of Christchurch, N.Z. The embryos were part of a full series, obtained from Stephen's Island in Cook's Straits, which had furnished Prof. Dendy with material for a monograph on the general development of the animal, now in course of publication; and the eggs were the survivors of a series of six from the same locality, one having died on Nov. 13. The material had been sent to Prof. Howes for the express purpose of working out the development of the skeleton. Prof. Howes directed attention to the interest attaching to that undertaking, in consideration of the central position of the species among terrestrial vertebrata, and briefly recapitulated the more important discoveries already announced by Dendy, with especial reference to the presence of an amniotic tube and of a third pair of incisor teeth, and to the occlusion of the olfactory passages during development.

Messrs. E. W. L. Holt and L. W. Byrne, F.Z.S., exhibited specimens and drawings of a small sucker-fish of the genus *Lepadogaster* considered to represent an undescribed species, for which they proposed the name *L. stictopteryx*.

This species was closely related to *L. bimaculatus* (Donov.), from which it could not be clearly distinguished by the radial formula alone. Distinctive characters of constant value seemed to be the more lateral position of the eyes and the different shape of the head, which was squarer in front than that of *L. bimaculatus*, combined with the elongation of the trunk and tail and the fleshy character of the anterior dorsal rays. Large specimens were readily distinguished by conspicuous dark spots on the dorsal and anal fins, which seemed to be constant in preserving media, though altered somewhat in tone; these markings were not exhibited by young examples. The body was of a varying shade of olive, which might be diversified by small brown specks and short white cross-bars and lines.

The specimens exhibited were 3 large individuals measuring from 33–37 mm. in length exclusive of the caudal fin, some small examples, newly hatched young, and some ova—all from Plymouth. The National collection contained a fine specimen of the same species from Loch Craignish in Argyllshire, at present labelled *L. bimaculatus*.

At Plymouth the habitat of *L. stictopteryx* appeared to be more littoral than that of *L. bimaculatus*, and the ova had been found in

the bulbs of *Laminaria bulbosa*; these ova seemed to be distinguishable from those of *L. bimaculatus* by the fixing apparatus of the *zona radiata*.

The observers proposed to communicate a more detailed description at an early date.

The following papers were read:—

1. A Revision of the Moths of the Subfamily *Pyraustinae* and Family *Pyralidae*. By Sir G. F. HAMPSON, Bart., F.Z.S., &c.

PART I.

[Received June 16, 1898.]

(Plates XLIX. & L.)

Family PYRALIDÆ.

Proboscis and maxillary palpi usually well developed; frenulum present. Fore wing with vein 1 *a* usually free, sometimes forming a fork with 1 *b*; 1 *c* absent; 5 from near lower angle of cell; 8, 9 almost always stalked. Hind wing with veins 1 *a*, *b*, *c* present; 5 almost always from near lower angle of cell; 8 approximated to 7 or anastomosing with it beyond the cell.

Larva elongate, with five pairs of prolegs. Pupa with segments 9–11 and sometimes also 8 and 12 movable, not protruding from cocoon on emergence.

PHYLOGENY OF THE PYRALIDÆ.

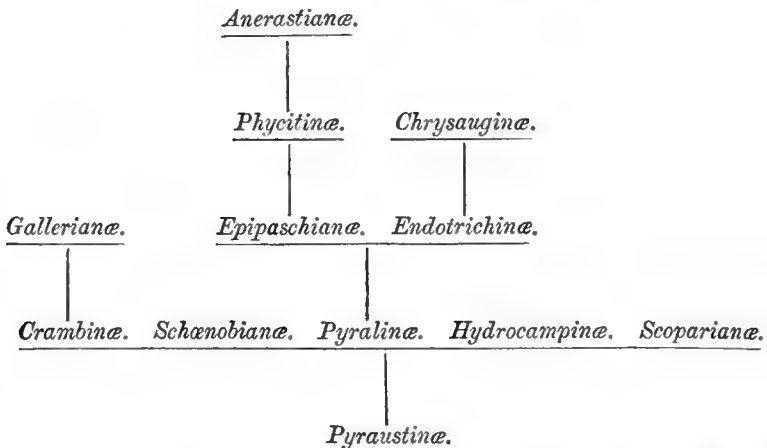

The most generalized subfamily is the *Pyraustinae* with veins 7 and 10 of fore wing from the cell; hind wing with the median nervure non-pectinate or rarely very slightly pectinate. From their lower division with correct palpi arose all the other subfamilies: (1) the

Scopariance, with tufts of raised scales in the cell of fore wing, from forms with dilated maxillary palpi such as *Pionea*; (2) the *Hydrocampinæ*, by vein 10 becoming stalked with 8, 9, from forms with filiform maxillary palpi; (3) the *Pyralinæ*, with vein 7 stalked with 8, 9, from a form with vein 8 of hind wing free, giving rise to (a) the *Endotrichinæ* with vein 8 anastomosing with 7, from which arose the *Chrysauginæ* with the maxillary palpi absent, and (b) the *Epipaschianæ* with tufts of scales in cell of fore wing, giving rise to the *Phycitinæ* with vein 7 of fore wing absent and the median nervure of hind wing pectinated, from which arose the *Anerastianæ* with the proboscis absent; (4) the *Schœnobianæ* with the proboscis absent; and (5) the *Crambinæ*, with the median nervure of hind wing strongly pectinated and the maxillary palpi triangularly scaled, giving rise to the *Gallerianæ* with the maxillary palpi slightly dilated or filiform.

Key to the Subfamilies.

- | | |
|--|---------------------------|
| A. Hind wing with the median nervure strongly pectinate on upperside. | |
| a. Fore wing with vein 7 present ¹ . | |
| a ¹ . Maxillary palpi not triangularly scaled ... | 1. <i>Gallerianæ</i> . |
| b ¹ . Maxillary palpi triangularly scaled | 2. <i>Crambinæ</i> . |
| b. Fore wing with vein 7 absent. | |
| a ¹ . Proboscis absent | 4. <i>Anerastianæ</i> . |
| b ¹ . Proboscis present | 5. <i>Phycitinæ</i> . |
| B. Hind wing with the median nervure non-pectinate on upperside ² . | |
| a. Proboscis absent | 3. <i>Schœnobianæ</i> . |
| b. Proboscis present ³ . | |
| a ¹ . Fore wing with vein 7 stalked with 8, 9. | |
| a ² . Fore wing with tufts of raised scales in cell | 6. <i>Epipaschianæ</i> . |
| b ² . Fore wing without tufts of raised scales in cell. | |
| a ³ . Hind wing with vein 8 anastomosing with 7. | |
| a ⁴ . Maxillary palpi absent | 7. <i>Chrysauginæ</i> . |
| b ⁴ . Maxillary palpi present | 8. <i>Endotrichinæ</i> . |
| b ³ . Hind wing with vein 8 free | 9. <i>Pyralinæ</i> . |
| b ¹ . Fore wing with vein 7 from the cell. | |
| a ² . Fore wing with vein 10 stalked with 8, 9 ⁴ | 10. <i>Hydrocampinæ</i> . |
| b ² . Fore wing with vein 10 from the cell. | |
| a ³ . Fore wing with tufts of raised scales in the cell | 11. <i>Scoparianæ</i> . |
| b ³ . Fore wing without tufts of scales in the cell | 12. <i>Pyraustinæ</i> . |

¹ Except in *Culladia*.

² Except slightly in *Psephis*, *Homophysa*, *Gonodiscus*, *Scybalista*, *Lipocosma*, *Voliba*, *Macaretæra*, and *Mnesictena*.

³ Except in a few genera of *Pyralinæ* to be distinguished from the *Schœnobianæ* by vein 8 of hind wing being free.

⁴ Except in a small percentage of specimens of a few species of *Nymphula* and *Oligostigma* to be distinguished from nearly all *Pyraustinæ* by the long maxillary palpi dilated at extremity.

Subfamily PYRAUSTINÆ.

Proboscis well developed. Fore wing with vein 1 *a* separate from 1 *b*; 7 from the cell. Hind wing with the median nervure non-pectinate on upperside, or rarely very slightly pectinated; 4, 5 from a point, rarely stalked; 7 almost always anastomosing with 8.

The accompanying phylogenetic table is worked out from an examination of the characters of all the genera, and the conclusion is reached that the ancestor of the *Pyralidæ* would possess the following generalized characters, all of which are found in one or other of the lower forms of the *Pyraustinæ*:—palpi porrect, the 3rd joint short, naked; maxillary palpi filiform; proboscis well developed; frons not prominent; antennæ simple; hind tibiæ with two pairs of spurs; fore wing with all the veins from cell; hind wing with all the veins from cell; 5 from middle of discocellulars; vein 8 approximated to but not anastomosing with 7; median nervure non-pectinate.

With these characters *Simæthistis* agrees except in having a frontal prominence and annulate antennæ, and *Metaprotus* is a close ally.

All the other genera have veins 8, 9 of fore wing stalked and fall into two natural groups, those with porrect palpi and those with upturned.

Tineodes, *Stenoptycha*, and *Lineodes* are Pterophorid-shaped genera, the 1st with vein 5 from middle of discocellulars, the 2nd with it absent.

Mimasarta has vein 5 of hind wing from above angle of cell and almost obsolete.

Noctuella, *Sceliodes*, &c. are genera with various frontal developments and the 3rd joint of palpi naked.

Pyrausta has the palpi triangularly scaled, the 3rd joint hidden in hair: from it are developed two large groups of genera—(1) with the maxillary palpi more or less dilated with scales, of which *Pionea* is typical, giving rise to *Mnesictena*, with the median nervure of hind wing pectinate; *Metasia*, *Titanio*, *Monocona*, &c., with various frontal developments; *Prochoristis*, with vein 6 of hind wing from below angle of cell; *Calamochrous*, *Mecyna*, *Noorda*, &c., with longer rostriform palpi, culminating in *Microcausta*, with vein 4 of hind wing absent; *Sparagmia* and *Terastiodes*, with the fore wing long and narrow, the termen excurved or angled at middle; and *Diasemia* &c., with the antennæ annulate: (2) genera that retain the filiform maxillary palpi, *Aplectropus*, tibiæ without spurs; genera such as *Phlyctænodes*, *Loxoneptera*, &c. with prominent frons; *Adeloides* and *Maruca* with very long antennæ; and *Ischnurges* with annulate antennæ.

Evergestis, *Omphisa*, *Archernis*, *Meroctena* are primitive forms with porrect palpi and the 3rd joint naked; *Furcivena* having veins 4, 5 of both wings stalked; and from a form like *Archernis* was developed the group with upturned palpi, *Neurophyseta* and

PHYLOGENY OF THE PYRAUSTINÆ.

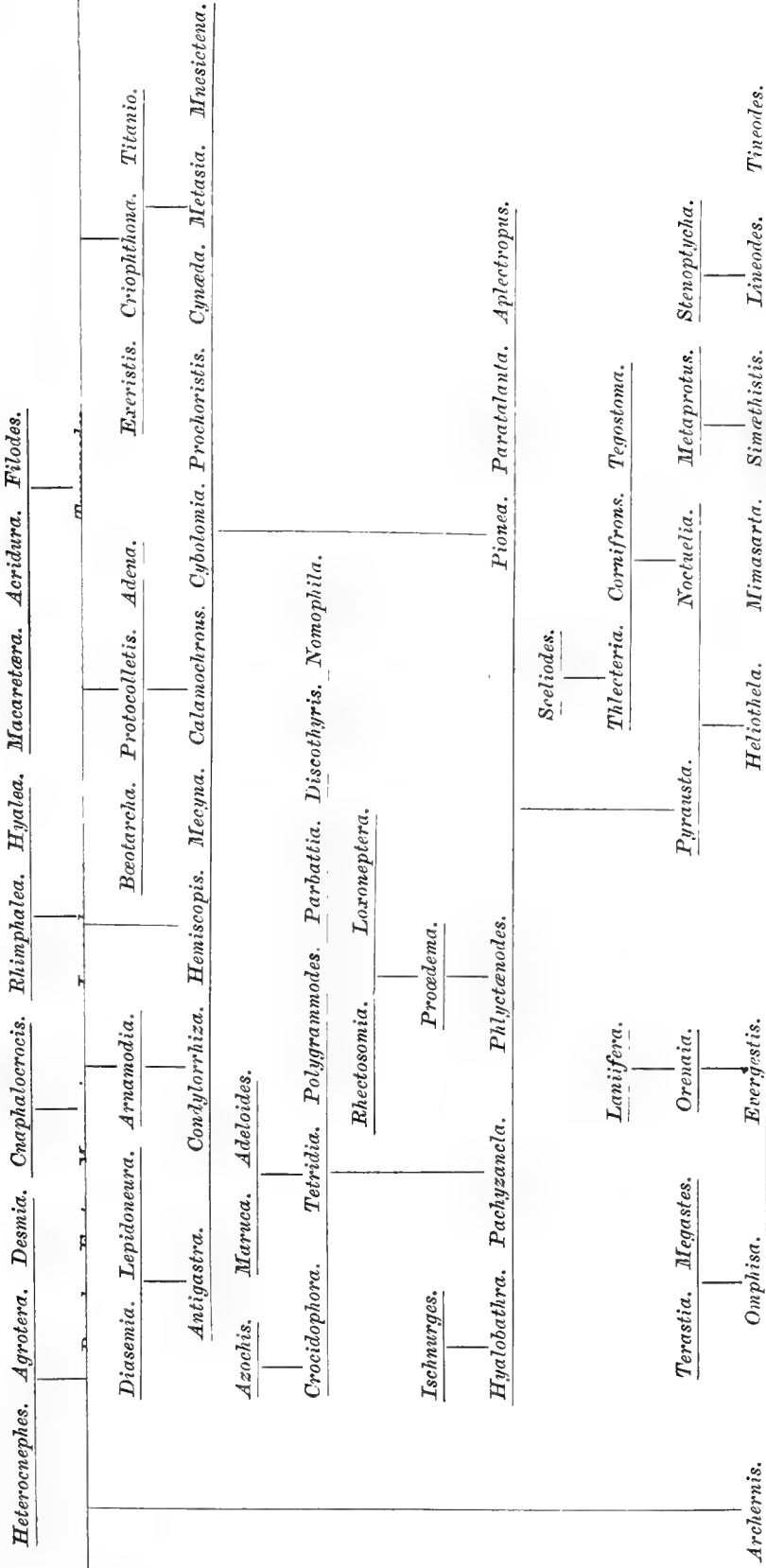

Orthoraphis having the 2nd joint porrect, the 3rd upturned, whilst all the others have the 2nd joint upturned, the 3rd being porrect in the group of genera of which *Leucinodes* and *Glyphodes* are typical.

Of the group with regularly upturned palpi, *Lygropia* is the most primitive, with the 3rd joint obtuse and naked and vein 7 of fore wing straight: from it arose (a) genera with vein 7 of fore wing curved and approximated to 8, 9, of which *Sylepta* and *Botyodes* are typical examples; (b) genera with a small triangular tuft of hair in front of 3rd joint of palpi, as in *Nacoleia*, giving rise to forms with longer palpi such as *Nosophora*, with annulate antennæ such as *Syngamia*, with vein 8 of hind wing anastomosing with 7 almost to the apex as in *Cnaphalocrocis*, and to forms with the triangular 3rd joint set on at an angle as in *Agrotera*; (c) genera with the palpi conically scaled and tapering to apex, of which *Dichocrocis*, *Nevrina*, and *Caprinia* are typical, *Filodes* with long antennæ, and *Macaretera* with the median nervure loosely pectinate and 4, 5 stalked, 4 being almost obsolete in male, being terminal branches; (d) a group of genera with the 3rd joint of palpi long and acuminate, of which *Tabidia*, *Entephria*, and *Sufetula* are typical, giving rise to a group with the median nervure loosely pectinate as in *Lipocosma* and *Symphysa*, *Homophysa* and *Psephis* being terminal branches with veins 10, 11 of fore wing stalked, the latter having the maxillary palpi dilated with scales.

The present paper completes the classification of the subfamilies of *Pyralidæ*; the *Crambinae* and *Schoenobianæ* were published in the P. Z. S. for 1895; the *Chrysauginæ* in the P. Z. S. for 1897; *Epipachianæ*, *Endotrichinæ*, and *Pyralinæ* in the Trans. Ent. Soc. for 1896, and the *Hydrocampinæ* in the Trans. Ent. Soc. for 1897; whilst the *Gallerianæ*, *Anerastianæ*, and *Phycitinæ* have been classified by E. L. Ragonot in the Romanoff Mémoires, vols. vii., viii., the latter volume, edited by myself after his death, being in the press. The allied family *Thyrididæ* also has been classified by me in the P. Z. S. for 1897, and the series will, I hope, be completed by a supplementary paper of additions and corrections now in preparation.

The use of the blocks from vol. iv. of the Moths in the 'Fauna of British India' has been kindly sanctioned by the Secretary of State for India. Examples of numerous new species have been presented to the British Museum, for purposes of description in this paper, by Mr. W. Schaus, Mr. H. J. Elwes, the Hon. W. Rothschild, and types have been lent by them, Prof. Poulton of the Oxford Museum, Mr. Herbert Druce, and many others.

As in the other papers of the series, the mark † indicates that the type is in the British Museum, a * that the species is not in the Museum; whilst at the end of the genera are lists of the species I have been unable to examine and the classification of which is uncertain. When it is stated that the types are in Coll. Rothschild and B.M., the type is in the former collection, a co-type in the latter.

Key to the Genera.

- A. Palpi upturned.
- a. Palpi with the 3rd joint long, naked and acuminate.
- a¹. Palpi with the 2nd joint porrect, the 3rd upturned.
- a². Both wings with veins 4, 5 stalked; fore wing with vein 6 absent 1. *Orthoraphis*.
- b². Both wings with veins 4, 5 from cell; fore wing with vein 6 present 2. *Neurophyseta*.
- b¹. Palpi with the 2nd joint upturned.
- a². Hind wing with the median nervure pectinated above.
- a³. Fore wing with veins 10, 11 stalked.
- a⁴. Maxillary palpi strongly dilated with scales 3. *Psephis*.
- b⁴. Maxillary palpi filiform 5. *Homophysa*.
- b³. Fore wing with veins 10, 11 from cell.
- a⁴. Maxillary palpi strongly dilated with scales 4. *Gonodiscus*.
- b⁴. Maxillary palpi long and filiform; frons oblique 6. *Scybalista*.
- a⁴. Maxillary palpi small; frons rounded.
- a⁵. Palpi with tufts of hair on 1st and 2nd joints in front; antennæ lamellate..... 10. *Lipocosma*.
- b⁵. Palpi with the 2nd joint fringed with long hair; antennæ annulate. 9. *Voliba*.
- b². Hind wing with the median nervure non-pectinate.
- a³. Maxillary palpi long and dilated with scales.
- a⁴. Antennæ ciliated; both wings with the outer margin excised below apex. 12. *Sufetula*.
- b⁴. Antennæ laminate; both wings with the outer margin evenly rounded.
- a⁵. Fore wing with veins 10, 11 stalked. 11. *Catapsephis*.
- b⁵. Fore wing with veins 10, 11 from cell 13. *Erpis*.
- b³. Maxillary palpi filiform and nearly as long as the labial 7. *Symphysa*.
- c³. Maxillary palpi filiform and much shorter than the labial.
- a⁴. Palpi with the 2nd joint short and not reaching vertex of head.
- a⁵. Antennæ with the shaft annulate ... 14. *Massepha*.
- b⁵. Antennæ with the shaft smooth.
- a⁶. Frons rounded.
- a⁷. Hind wing with veins 3, 4, 5 approximated for a short distance 20. *Rehimena*.
- b⁷. Hind wing with veins 4, 5 approximated for a short distance 21. *Zinckenia*.
- c⁷. Hind wing with veins 4, 5 not approximated towards origin. 22. *Tabidia*.
- b⁶. Frons flat and oblique; hind wing with veins 4, 5 not approximated towards origin 19. *Ravanoa*.

- b⁴. Palpi with the 2nd joint reaching vertex of head.
 a⁵. Fore wing with vein 7 straight and well separated from 8, 9.
 a⁶. Antennæ with the shaft annulate.
 b⁶. Antennæ with the shaft smooth... 15. *Aulacoptera*.
 b⁵. Fore wing with vein 7 curved and approximated to 8, 9 for some distance. 18. *Entephria*.
 a⁶. Fore wing with veins 4, 5 stalked. 16. *Xanthomelæna*.
 b⁶. Fore wing with veins 4, 5 from cell 17. *Rhimphaleodes*.
- b. Palpi with the 3rd joint short, naked, and obtuse.
 a¹. Maxillary palpi dilated with scales.
 a². Palpi with the 2nd joint broadly scaled in front; fore wing with the outer margin evenly curved..... 23. *Eurrhparodes*.
 b². Palpi with the 2nd joint smoothly scaled; fore wing with the outer margin much excurved at middle 63. *Achantodes*.
 b¹. Maxillary palpi filiform.
 a². Palpi with no tuft of hair at end of 2nd joint.
 a³. Palpi with the 2nd joint moderately and evenly scaled in front.
 a⁴. Fore wing with vein 7 nearly straight and well separated from 8, 9 72. *Lygropia*.
 b⁴. Fore wing with vein 7 curved and approximated to 8, 9.
 a⁵. Abdomen long, with lateral tufts on proximal segments..... 64. *Piletosoma*.
 b⁵. Abdomen normal 70. *Sylepta*.
 b³. Palpi with the 2nd joint broadly rounded with scales in front.
 a⁴. Fore wing with vein 2 from near base of cell; 4, 5 and 6, 7 approximated for some distance 62. *Erinothus*.
 b⁴. Fore wing with vein 2 from middle of cell; 4, 5 separate.
 a⁵. Fore wing with vein 7 curved and approximated to 8, 9..... 67. *Botyodes*.
 b⁵. Fore wing with vein 7 straight and well separated from 8, 9 71. *Endographis*.
 c³. Palpi with the 2nd joint broadly angled with scales in front.
 a⁴. Fore wing with vein 7 curved and approximated to 8, 9, the outer margin excised below apex 66. *Ceratarcha*.
 b⁴. Fore wing with vein 7 straight and well separated from 8, 9, the outer margin evenly curved 61. *Goniorhynchus*.
 a³. Palpi with the 2nd joint long and with a tuft of hair at extremity hiding the 3rd joint.
 a⁴. Antennæ with the shaft smooth; fore wing with vein 7 curved and approximated to 8, 9 65. *Deba*.
 b⁴. Antennæ with the shaft annulate; fore wing with vein 7 straight and well separated from 8, 9 40. *Salbiomorpha*.

- b³. Palpi with the 3rd joint greatly tufted with hair, the 2nd reaching above vertex of head; maxillary palpi dilated with scales.
 a³. Fore wing with vein 7 curved and approximated to 8, 9..... 68. *Authæretis*.
 b³. Fore wing with vein 7 straight; the apex forming a lobe with the outer margin excised below it..... 8. *Monocoptopera*.
 c. Palpi with a triangular tuft in front of 3rd joint.
 a¹. Palpi with the tuft on 3rd joint long, pointed, and extending to the front of the broadly fringed 2nd joint.
 a². Fore wing with vein 7 curved and approximated to 8, 9 for about one-third length. 24. *Heterocnephes*.
 b². Fore wing with vein 7 straight and well separated from 8, 9 28. *Pagyda*.
 b¹. Palpi with the tuft on 3rd joint short.
 a². Palpi with the 3rd joint short and blunt.
 a³. Palpi with the triangular 3rd joint set on at an angle 25. *Agrotera*.
 b³. Palpi with the 3rd joint not set on at an angle.
 a⁴. Hind wing with vein 7 anastomosing with 8 almost to apex.
 a⁵. Fore wing with veins 10, 11 stalked. 30. *Cnaphalocrocis*.
 b⁵. Fore wing with vein 10 free and closely approximated to 8, 9 31. *Marasmia*.
 b⁴. Hind wing with vein 7 anastomosing with 8 to about three-fourths of wing.
 a⁵. Fore wing with veins 10, 11 stalked. 36. *Hilithæia*.
 b⁵. Fore wing with vein 10 from cell.
 a⁶. Antennæ with the shaft annulate.
 a⁷. Maxillary palpi extremely minute 29. *Ercta*.
 b⁷. Maxillary palpi well developed.
 a⁸. Antennæ longer than the fore wing; fore wing with vein 7 curved and approximated to 8, 9..... 32. *Rhimphalea*.
 b⁸. Antennæ shorter than the fore wing.
 a⁹. Fore wing with vein 7 curved and approximated to 8, 9.
 a¹⁰. Frons with a rounded prominence 33. *Hyalea*.
 b¹⁰. Frons not prominent... 34. *Leucochroma*.
 b⁹. Fore wing with vein 7 straight and well separated from 8, 9 35. *Syngamia*.
 b⁶. Antennæ with the shaft not annulate.
 a⁷. Hind wing with veins 3, 4, 5 approximated for a short distance. 26. *Desmia*.
 b⁷. Hind wing with veins 3, 4 approximated, 5 from above angle of cell 27. *Ætholix*.
 c⁷. Hind wing with vein 3 not approximated to 4.
 a⁸. Frons with oblique prominence; palpi with the 2nd joint broadly scaled 38. *Trithyris*.

- b*². Frons flat and oblique.
*a*². Fore wing with vein 7 curved and approximated to 8, 9..... 37. *Samea*.
*b*². Fore wing with vein 7 straight and well separated from 8, 9 39. *Bocchoris*.
*c*². Frons rounded.
*a*². Fore wing with vein 7 curved and approximated to 8, 9..... 41. *Pilocrocis*.
*b*². Fore wing with vein 7 straight and well separated from 8, 9 60. *Nacoleia*.
*b*². Palpi with the 3rd joint long and acuminate.
*a*³. Palpi with the tuft on 3rd joint forming a downcurved hook 45. *Mesocondyla*.
*b*³. Palpi with the tuft on 3rd joint not hooked.
*a*⁴. Palpi erect, not recurved.
*a*⁵. Fore wing with vein 7 curved and approximated to 8, 9 42. *Ulopeza*.
*b*⁵. Fore wing with vein 7 straight and well separated from 8, 9 44. *Chalcidoptera*.
*b*⁴. Palpi recurved over head, in male long with a large tuft of curved hair in front 43. *Nosophora*.
d. Palpi with the 3rd joint evenly fringed with scales in front and well developed 46. *Leucophotis*.
e. Palpi with the 2nd and 3rd joints conically scaled and tapering to apex.
*a*¹. Hind wing with veins 4, 5 from the cell.
*a*². Maxillary palpi dilated with scales.
*a*³. Hind wing with veins 4, 5 not approximated; palpi of male with the 3rd joint long, hollowed out and containing a tuft of hair 69. *Prorodes*.
*b*³. Hind wing with veins 4, 5 approximated for a short distance 47. *Caprinia*.
*b*². Maxillary palpi filiform.
*a*³. Frons rounded and not prominent.
*a*⁴. Fore wing with vein 7 curved and approximated to 8, 9 for about one-third length.
*a*⁵. Hind wing with veins 4, 5 not approximated towards origin 56. *Phryganodes*.
*b*⁵. Hind wing with veins 4, 5 approximated for a short distance.
*a*⁶. Antennæ almost simple 54. *Nevrina*.
*b*⁶. Antennæ annulate 48. *Spilomela*.
*b*⁴. Fore wing with vein 7 nearly straight and well separated from 8, 9.
*a*⁵. Palpi cylindrical and reaching vertex of head.
*a*⁶. Hind tibiæ with the medial spurs absent in male, the inner medial spur minute in female 58. *Oligocentris*.
*b*⁶. Hind tibiæ with the inner medial spur well developed 59. *Dichocrocis*.
*b*⁵. Palpi flattened against frons and not reaching vertex of head 55. *Dichogama*.

- b*³. Frons flat and oblique.
- a*⁴. Hind wing with veins 4, 5 approximated for a short distance 52. *Tyspanodes*.
- b*⁴. Hind wing with veins 4, 5 not approximated towards origin 53. *Conchyloides*.
- c*³. Frons with a rounded prominence.
- a*⁴. Antennæ about one and a half times length of fore wing; fore wing broad. 51. *Filodes*.
- b*¹. Antennæ shorter than fore wing.
- a*⁵. Fore wing long and narrow, vein 7 curved and approximated to 8, 9; hind wing with veins 3, 4, 5 approximated..... 50. *Acridura*.
- b*⁵. Fore wing subtriangular; vein 7 straight and well separated from 8, 9; hind wing with veins 3, 4, 5 not approximated towards origin. . 57. *Proconica*.
- b*¹. Hind wing with veins 4, 5 stalked, 4 almost obsolete in male..... 49. *Macaretæra*.
- f*. Palpi with the 3rd joint porrect.
- a*¹. Palpi with the 2nd joint broadly fringed with hair in front, the 3rd lying on it.
- a*². Maxillary palpi strongly dilated with scales.
- a*³. Fore wing with vein 7 curved and approximated to 8, 9 for a short distance.
- a*⁴. Hind wing with veins 4, 5 approximated for a short distance; fore wing long and narrow 73. *Agathodes*.
- b*⁴. Hind wing with veins 4, 5 not approximated towards origin 74. *Glyphodes*.
- b*³. Fore wing with vein 7 nearly straight and well separated from 8, 9.
- a*⁴. Antennæ longer than fore wing, which is long and narrow 78. *Euclasta*.
- b*⁴. Antennæ shorter than fore wing, which is broad 75. *Cliniodes*.
- b*². Maxillary palpi filiform.
- a*³. Fore wing with vein 7 curved and approximated to 8, 9 for some distance.
- a*⁴. Hind wing with veins 4, 5 not approximated towards origin 76. *Pygospila*.
- b*⁴. Hind wing with veins 4, 5 approximated for a short distance 79. *Polythlipta*.
- b*³. Fore wing with vein 7 nearly straight and well separated from 8, 9 80. *Lepyrodes*.
- b*¹. Palpi with the 2nd joint moderately scaled in front, the 3rd projecting free.
- a*². Frons rounded and not prominent.
- a*³. Fore wing with vein 7 curved and approximated to 8, 9 77. *Heortia*.
- b*³. Fore wing with vein 7 straight and well separated from 8, 9 84. *Metrea*.
- b*². Frons flat and oblique; antennæ annulate. 81. *Syllepis*.
- c*². Frons with a rounded prominence.
- a*³. Palpi with the 3rd joint minute; hind wing with veins 4, 5 approximated for a short distance..... 82. *Analyta*.
- b*³. Palpi with the 3rd joint long; hind wing with veins 4, 5 well separated at origin 83. *Leucinodes*.

- g.* Palpi obliquely upturned, the 3rd joint well developed and obtuse.
- a*¹. Palpi with the 2nd joint fringed in front with long hair 86. *Ommatospila*.
- b*¹. Palpi with tufts of hair at end of 1st and 2nd joints in front.
- a*². Maxillary palpi dilated with scales; hind wing with veins 3, 4, 5 approximated for a short distance 85. *Crocidolomia*.
- b*². Maxillary palpi filiform; hind wing with veins 4, 5 not approximated towards origin 87. *Hellula*.
- h.* Palpi porrect.
- a*¹. Palpi with the 3rd joint hidden in hair.
- a*². Palpi rostriform, the 3rd joint down-curved.
- a*³. Palpi projecting about twice the length of head.
- a*⁴. Hind wing with vein 4 absent 125. *Microcausta*.
- b*⁴. Hind wing with veins 4, 5 stalked; fore wing with scale-tooth on inner margin; frons with conical prominence 140. *Endolophia*.
- c*⁴. Hind wing with veins 4, 5 approximated for a short distance.
- a*⁵. Maxillary palpi with a pointed tuft of hair at extremity 126. *Noorda*.
- b*⁵. Maxillary palpi strongly dilated with scales.
- a*⁶. Frons with a conical prominence 130. *Baotarcha*.
- b*⁶. Frons flat and oblique.
- a*⁷. Abdomen and legs long and slender 117. *Lepidoneura*.
- b*⁷. Abdomen and legs short and moderately stout 129. *Mecyna*.
- c*⁶. Frons rounded.
- a*⁷. Antennæ with the shaft annulate 131. *Atelocentra*.
- b*⁷. Antennæ with the shaft smooth; fore wing with vein 10 usually anastomosing with 8, 9..... 132. *Protocolletis*.
- d*⁴. Hind wing with veins 4, 5 not approximated towards origin.
- a*⁵. Fore wing with the outer margin angled at middle 133. *Adena*.
- b*⁵. Fore wing with the outer margin evenly curved 134. *Calamochrous*.
- b*³. Palpi projecting about the length of head.
- a*⁴. Fore wing broad, the costa lobed at base; hind wing with veins 3, 4, 5 approximated for a short distance ... 123. *Agastya*.
- b*⁴. Fore wing subtriangular; hind wing with veins 3, 4, 5 not approximated 124. *Protrigonia*.
- b*². Palpi straight and triangularly scaled.
- a*³. Frons rounded or flat and not prominent.
- a*⁴. Antennæ more than one and a half times length of fore wing..... 105. *Adeloides*.

- b⁴.** Antennæ from one to one and a half times length of fore wing.
a⁵. Antennæ with the shaft annulated; fore wing with veins 4, 5 closely approximated for a short distance. 104. *Maruca*.
b⁵. Antennæ with the shaft smooth; fore wing with veins 4, 5 not approximated towards origin 106. *Tetridia*.
c⁴. Antennæ shorter than the fore wing.
a⁵. Maxillary palpi with a pointed tuft of hair at extremity.
a⁶. Hind wing with vein 5 from above angle of cell and almost obsolete 156. *Mimasarta*.
b⁶. Hind wing with vein 5 from lower angle of cell and fully developed.
a⁷. Fore wing with vein 7 curved and approximated to 8, 9 127. *Dausara*.
b⁷. Fore wing with vein 7 straight and well separated from 8, 9.
a⁸. Frons rounded; hind wing with veins 4, 5 approximated for a short distance 128. *Hemiscopis*.
b⁸. Frons oblique 135. *Cybolomia*.
b⁵. Maxillary palpi strongly dilated with scales at extremity.
a⁶. Antennæ with the shaft annulate; hind wing with outer margin somewhat excised below apex ... 116. *Diasemia*.
b⁶. Antennæ with the shaft not annulate.
a⁷. Legs very long and slender; fore femora and tibiæ fringed in male with long hair 118. *Antigastra*.
b⁷. Legs of moderate length.
a⁸. Fore wing with vein 7 strongly curved and approximated to 8, 9.
a⁹. Fore wing long and narrow, the outer margin angled at middle 120. *Sparagmia*.
b⁹. Fore wing long and narrow, the outer margin strongly excurved at middle.
a¹⁰. Fore wing with the inner margin not excised before outer angle. 121. *Arnamodia*.
b¹⁰. Fore wing with the inner margin excised before outer angle, where there is a scale-tooth ... 119. *Liopasia*.
c⁹. Fore wing subtriangular ... 122. *Condylorrhiza*.
b⁸. Fore wing with vein 7 straight and well separated from 8, 9.
a⁹. Hind wing with vein 6 from upper angle of cell.
a¹⁰. Fore wing with scale-tooth on inner margin before middle 137. *Cynæda*.

- b*¹⁰. Fore wing with no scale-tooth on inner margin.
*a*¹¹. Hind wing with the median nervure loosely pectinated above 145. *Mnesictena*.
*b*¹¹. Hind wing with the median nervure not pectinated 146. *Pionea*.
*b*⁹. Hind wing with vein 6 from below upper angle of cell 136. *Prochoristis*.
*c*⁵. Maxillary palpi filiform or hardly dilated with scales at extremity.
*a*⁶. Tibiæ without spurs 148. *Aplectropus*.
*b*⁶. Tibiæ with spurs.
*a*⁷. Hind wing with veins 3, 4, 5 approximated for a short distance 108. *Parbattia*.
*b*⁷. Hind wing with veins 4, 5 approximated for a short distance, 3 separate.
*a*⁸. Hind wing with vein 7 anastomosing with 8.
*a*⁹. Fore wing subtriangular, vein 3 from close to angle of cell.
*a*¹⁰. Build stout 107. *Polygrammodes*.
*b*¹⁰. Build slender.
*a*¹¹. Fore wing with the apex acute, the outer margin angled at vein 4; hind wing with the outer margin produced at vein 6 and excurved at middle, a large tuft of hair at lower angle of cell 109. *Discothyris*.
*b*¹¹. Both wings with the outer margin evenly curved.
*a*¹². Frons flat and oblique.
*a*¹³. Fore wing with vein 7 curved and approximated to 8, 9 ... 102. *Azochis*.
*b*¹³. Fore wing with vein 7 straight and well separated from 8, 9 ... 103. *Crocidophora*.
*b*¹². Frons rounded 111. *Pachyzancla*.
*b*⁹. Fore wing long and narrow, vein 3 from well before angle of cell 110. *Nomophila*.
*b*⁸. Hind wing with vein 7 not anastomosing with 8; fore wing long and narrow 94. *Terastia*.
*c*⁷. Hind wing with veins 4, 5 not approximated towards origin.
*a*⁸. Antennæ with the shaft annulated with rings at the joints..... 100. *Ischnurges*.
*b*⁸. Antennæ with the shaft smooth and ciliated.
*a*⁹. Hind tibiæ with the spurs all long and equal 101. *Hyalobathra*.

- b*³. Hind tibiae with the outer medial spur not more than two-thirds length of inner.
- a*¹⁰. Fore wing with vein 7 curved and approximated to 8, 9 147. *Paratalanta*.
- b*¹⁰. Fore wing with vein 7 straight and well separated from 8, 9 149. *Pyrausta*.
- b*³. Frons with a long corneous prominence with vertical edge excised in front 139. *Monocona*.
- c*³. Frons with long truncate conical prominence 142. *Criophthona*.
- d*³. Frons with pointed conical prominence.
- a*⁴. Hind wing with veins 4, 5 stalked ... 141. *Autocosmia*.
- b*⁴. Hind wing with veins 4, 5 from cell 115. *Phlyctænodes*.
- e*³. Frons with rounded prominence.
- a*⁴. Fore wing with the apex produced and acute, the outer margin excised below apex 112. *Rhectosomia*.
- b*⁴. Fore wing with the apex not produced, the outer margin evenly curved.
- a*⁵. Antennæ with the shaft annulate with rings at the joints 138. *Exeristis*.
- b*⁵. Antennæ with the shaft smooth.
- a*⁶. Maxillary palpi dilated with scales; hind wing with veins 4, 5 not approximated towards origin.
- a*⁷. Palpi fringed with long hair below 143. *Titania*.
- b*⁷. Palpi moderately scaled 144. *Metasia*.
- b*⁶. Maxillary palpi filiform; hind wing with veins 4, 5 approximated for a short distance 114. *Proxalema*.
- f*³. Frons flattened and produced to a rounded extremity; fore wing of male with tufts of hair on inner margin; hind wing with tufts near lower angle of cell 113. *Loxoneptera*.
- b*¹. Palpi with the 3rd joint naked.
- a*². Fore wing with veins 8, 9 stalked.
- a*³. Hind wing with vein 5 from lower angle of cell.
- a*⁴. Frons with long corneous plate with vertical edge 152. *Cornifrons*.
- b*⁴. Frons with horizontal corneous plate excised in front 153. *Tegostoma*.
- c*⁴. Frons with conical prominence.
- a*⁵. Palpi extending about 2½ times length of head 150. *Sceliodes*.
- b*⁵. Palpi extending about the length of head 151. *Thlecteria*.
- d*⁴. Frons with rounded prominence 154. *Noctuella*.
- e*⁴. Frons rounded or flat and not prominent.
- a*⁵. Fore and hind wings with veins 4, 5 stalked 89. *Furcivena*.

- b*⁵. Fore and hind wings with veins 4, 5 from cell.
- a*⁶. Palpi with the 3rd joint down-curved.
- a*⁷. Fore wing with the apex much produced; and falcate; vein 7 curved and approximated to 8, 9 88. *Megaphysa*.
- b*⁷. Fore wing with the apex not produced, vein 7 straight and well separated from 8, 9 90. *Sameodes*.
- b*⁶. Palpi straight and not down-curved at extremity.
- a*⁷. Antennæ with the shaft smooth.
- a*⁸. Palpi with the 2nd joint fringed above and below with hair.
- a*⁹. Fore wing with vein 7 curved and approximated to 8, 9 91. *Meroctena*.
- b*⁹. Fore wing with vein 7 straight and well separated from 8, 9 92. *Thliptoceras*.
- b*⁸. Palpi with the 2nd joint fringed with very long hair below.
- a*⁹. Fore wing with vein 7 curved and approximated to 8, 9 97. *Laniifera*.
- b*⁹. Fore wing with vein 7 straight and well separated from 8, 9 98. *Oreanaia*.
- c*⁸. Palpi with the 2nd joint moderately fringed with hair below towards extremity.
- a*⁹. Maxillary palpi triangularly scaled.
- a*¹⁰. Fore wing with vein 7 curved and approximated to 8, 9; build stout; antennæ of male bipectinate 95. *Megastes*.
- b*¹⁰. Fore wing with vein 7 straight and well separated from 8, 9; build slight; antennæ ciliated. 155. *Heliothela*.
- b*⁹. Maxillary palpi slightly dilated with scales 93. *Archernis*.
- c*⁹. Maxillary palpi long and filiform.
- a*¹⁰. Both wings with the outer margin excurved at middle; build stout. 96. *Omphisa*.
- b*¹⁰. Both wings with the outer margin evenly curved; build slight ... 99. *Evergestis*.
- b*⁷. Antennæ with the shaft annulate, and longer than fore wing; legs long and slender; hind wing with vein 7 anastomosing with 8 to $\frac{3}{4}$ of wing 160. *Lineodes*.

- ♂³. Hind wing with vein 5 absent, coincident with 4; 7 becoming coincident with 8; antennæ annulate 159. *Stenoptycha*.
 ♂³. Hind wing with vein 5 from middle of discocellulars, 7 becoming coincident with 8; palpi about three times length of head; antennæ annulate 161. *Tineodes*.
 ♀². Fore wing with veins 8, 9 from cell.
 *a*³. Frons with pointed conical prominence; hind wing with vein 5 from above angle of cell 157. *Metaprotus*.
 ♂³. Frons with rounded prominence; hind wing with vein 5 from middle of discocellulars 158. *Simæthistis*.

Genus 1. ORTHORAPHIS.

Orthoraphis Hmps. Moths Ind. iv. p. 251 (1896).

Palpi with the 2nd joint porrect and fringed with hair above and below, the 3rd upturned, well developed, and acuminate; maxillary palpi long and dilated with scales at extremity; frons rounded; antennæ thickened and flattened; tibiæ with the outer spurs nearly as long as the inner. Fore wing long and narrow; the outer margin excised below apex and towards outer angle, excurved at middle; vein 3 from before angle of cell; 4, 5 stalked; 6 absent; 7 straight and well separated from 8, 9. Hind wing with vein 3 from near angle of cell; 4, 5 stalked; 6, 7 from upper angle, 7 anastomosing with 8, the outer margin excised below apex and towards anal angle.

Fig. 1.

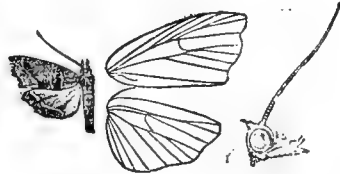

Orthoraphis obfuscata, ♂. †. (From Moths Ind. vol. iv.)

Type. (1)†*ORTHORAPHIS OBFUSCATA* Hmps. Ill. Het. ix. p. 161, pl. 172. f. 4. Ceylon.

(2) *ORTHORAPHIS METASTICTA*, n. sp.

♂. Pale ochreous brown; palpi blackish at sides. Fore wing with series of pale dark-centred semicircular marks on medial part of costa; an ill-defined oblique antemedial black band from cell to inner margin; a speck in cell and prominent discocellular spot; an interrupted postmedial black-edged white line, strongly incurved below vein 5, bent outwards again to vein 1; a fine marginal black line; the base of cilia whitish. Hind wing whitish; a discocellular black speck; a short postmedial line between veins 5 and 2; the outer area fuscous, with a marginal black mark on vein 2;

a deep black patch on anal lobe crossed by a white bar; cilia with a white line at base, at anal lobe white with black tips.

Hab. Khásis; Mindoro. *Exp.* 18 mm. Type in Coll. Rothschild.

Genus 2. NEUROPHYSETA.

Neurophyseta Hmps. A. M. N. H. (6) xvi. p. 333 (1895).

Palpi with the 2nd joint porrect, the 3rd well developed, upturned and acuminate; maxillary palpi filiform; frons rounded; antennæ of male thickened and flattened; tibiæ with the spurs long and nearly equal. Fore wing with the apex rectangular; vein 3 from near angle of cell; 4, 5 from angle; 7 straight and well-separated from 8, 9, to which 10 is approximated. Male with a glandular swelling on vein 1 before middle. Hind wing with veins 3, 4, 5 from angle of cell; 7 from before upper angle and anastomosing with 8.

Fig. 2.

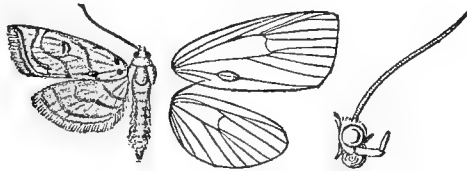

Neurophyseta clymenalis, ♂. ♀.

Type. †NEUROPHYSETA CLYMENALIS Wlk. xvii. 459. Neotropical region.

†*Hydrocampa laothoealis* Wlk. xvii. 460.

† „ „ *laudamialis* Wlk. xix. 959 (var.).

†*Leucochroma subpuralis* Wlk. xxxiv. 1353.

Stenia præstrictalis Led. Wien. Ent. Mon. 1863, p. 502, pl. 18. f. 12.

Genus 3. PSEPHIS.

Psephis Guen. Delt. & Pyr. p. 257 (1854).

Palpi upturned, the 2nd joint fringed with long hair in front and hardly reaching vertex of head, the 3rd long, naked, and

Fig. 3.

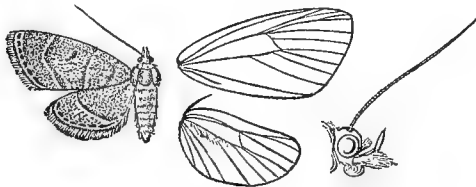

Psephis myrmidonalis, ♂. ♀.

acuminate; maxillary palpi strongly dilated with scales; frons rounded; antennæ almost simple; tibiæ with the spurs long and

nearly equal. Fore wing with vein 3 from near angle of cell; 4, 5 from angle; 7 straight, and well separated from 8, 9; 10, 11 stalked, and closely approximated to 8, 9. Hind wing with the median nervure strongly pectinated; vein 3 from near angle of cell; 4, 5 approximated for a short distance; 6, 7 from upper angle, 7 anastomosing with 8.

Type. PSEPHIS MYRMIDONALIS Guen. Delt. & Pyr. p. 257, pl. 7. f. 8. Brazil. *Scybalista trifunalis* Led. Wien. Ent. Mon. 1863, p. 455, pl. 18. f. 16.

Genus 4. GONODISCUS.

Gonodiscus Warr. A. M. N. H. 1891, i. p. 430.

Palpi upturned, the 2nd joint fringed with hair in front and reaching above vertex of head, the 3rd well developed and acuminate; maxillary palpi triangularly dilated with scales; frons rounded; antennæ somewhat laminate; tibiæ with the outer spurs two-thirds length of inner; abdomen long. Fore wing with vein 3 from before angle of cell; 4, 5 well separated at origin; 7 curved but not approximated to 8, 9, from which 10 is well separated. Hind wing with the median nervure pectinated above; vein 3 from before angle of cell; 4, 5 from angle; 6, 7 shortly stalked, 7 anastomosing with 8.

Fig. 4.

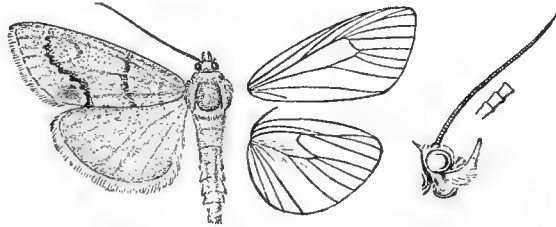

Gonodiscus amplalis, ♂. †.

Type. (1)†GONODISCUS AMPLALIS Warr. A. M. N. H. 1891, i. p. 430.

Chili

(2)†GONODISCUS AUSTRALIENSIS, n. sp. (Plate XLIX. fig. 1.)

Straw-yellow; thorax tinged with orange. Fore wing with a brown fascia on costa from base to the curved brown antemedial line, which is thick; the postmedial thick brown line excurved at middle, the terminal area from just beyond it suffused with brown; a terminal series of brown points on yellow marks. Hind wing slightly suffused with fuscous and with traces of a curved sub-terminal line.

The 3rd joint of palpus is shorter and more obtuse than in *amplalis*.

Hab. W. Australia, Sherlock R. (*Clement*); Queensland, Coomoo (*Barnard*). *Exp.* 20 mm.

Genus 5. HOMOPHYSA.

Homophysa Guen. Delt. & Pyr. p. 364 (1854).

Palpi upturned, the 2nd joint reaching vertex of head, tufts of hair at extremity of 1st and 2nd joints; the 3rd well developed and acuminate; maxillary palpi long and filiform; antennæ of male thickened and flattened; tibiæ with the outer spurs two-thirds length of inner. Fore wing with vein 3 from near angle of cell; 7 straight and well separated from 8 and 9; 10, 11 stalked. Hind wing with the median nervure slightly pectinated above; veins 4, 5 approximated for a short distance; 6, 7 from upper angle, 7 anastomosing with 8.

Fig. 5.

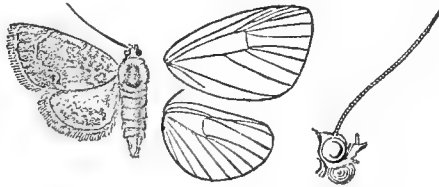

Homophysa glaphyralis, ♂. $\frac{3}{2}$.

- Type.* (1) HOMOPHYSA GLAPHYRALIS Guen. Delt. & Pyr. p. 366; Led.
Wien. Ent. Mon. 1863, pl. 18. f. 14. U.S.A.
†*Scopula stipatalis* Wlk. xxxiv. 1460.
Homophysa albolineata Grote, Can. Ent. x. p. 28.
- (2) HOMOPHYSA SESQUISTRALIS Hübn. Zutr. ii. 29, 185. ff. 369,
370. U.S.A.; Honduras.
†*Zebronia dimotalis* Wlk. xxxiv. 1346.
- (3)†HOMOPHYSA RENICULALIS Zell. Verh. z.-b. Ver. Wien, 1872,
p. 526. U.S.A.
- (4) HOMOPHYSA INVISALIS Guen. Delt. & Pyr. p. 361.
U.S.A.; Cayenne.
† „ *lentiflualis* Zell. Verh. z.-b. Ver. Wien, 1872, p. 525.
- (5)†HOMOPHYSA DECISA Wlk. xxxv. 1963.
Jamaica; Brazil; Argentina.
- (6) HOMOPHYSA FULMINALIS Led. Wien. Ent. Mon. 1863, p. 455,
pl. 18. f. 13. U.S.A.
- (7)†HOMOPHYSA POLYCYMA, n. sp. (Plate XLIX. fig. 4.)
♂. Head and thorax bright yellow, mixed with white; abdomen ochreous, with fine white segmental lines. Fore wing orange-yellow, with six strongly dentate white transverse lines; the area from middle to near termen white suffused with brown, except towards costa; a terminal white line. Hind wing white, with indistinct curved postmedial line.

♀ with the hind wing slightly suffused with fuscous except towards costa and inner margin.

Hab. Brazil, Castro Paraña. *Exp.* 16 mm.

(8)†*HOMOPHYSA BILINEALIS* Wlk. xxxiv. 1346. U.S.A.; Venezuela.
† „ *peremptalis* Grote, Can. Ent. x. p. 28.

(9)†*HOMOPHYSA LEUCOSTICTALIS* Hmps. A. M. N. H. 1895, ii.
p. 334. W. Indies.

(10)†*HOMOPHYSA FALCATALIS* Hmps. A. M. N. H. 1895, ii.
p. 333. W. Indies.

Auctorum.

Homophysa micralis Guen. Delt. & Pyr. p. 366. Brazil.

„ *crambidalis* Snell. Tijd. v. Ent. xxx. p. 62, pl. 5. f. 5.
Curacao.

Orobena reluctalis Hulst, Tr. Am. Ent. Soc. xiii. p. 156. U.S.A.

Botys psychicalis Hulst, Tr. Am. Ent. Soc. xiii. p. 149. U.S.A.

Homophysa dolatalis Möschl. Abh. Senck. Ges. xvi. p. 321.

Porto Rico.

Genus 6. *SCYBALISTA*.

Scybalista Led. Wien. Ent. Mon. 1863, p. 455.

Eupoca Warr. A. M. N. H. (6) viii. p. 63.

Palpi upturned, the 1st joint fringed with hair in front, the 2nd reaching vertex of head, the 3rd well developed and acuminate; maxillary palpi long and filiform; frons flat and oblique; antennæ of male laminate; tibiæ with the spurs long and nearly equal. Fore wing with the inner margin fringed with hair at middle; vein 3 from before angle of cell; 4, 5 from angle; 7 straight and well separated from 8, 9; 10, 11 free. Hind wing with the median nervure pectinated above; vein 3 from angle of cell; 4, 5 approximated for a short distance; 6, 7 from upper angle, 7 anastomosing with 8.

Fig. 6.

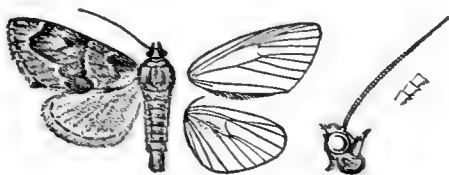

Scybalista bifascialis, ♂. $\frac{3}{2}$.

(1)†*SCYBALISTA LEUCOLEPIA*, n. sp.

♀. Head and thorax black, with long white scales; abdomen ochreous white, with some black dorsal suffusion on medial segments. Fore wing black, the base of inner margin white; long white scales on basal area; an obscure white antemedial line

angled below costa and then very oblique; a medial white line angled on vein 2, the area between it and the postmedial line suffused with white and with a white discoidal lunule; the postmedial line angled below costa, then incurved to inner margin, the area beyond it brown with terminal series of black points. Hind wing yellowish white; with traces of curved postmedial series of black points and prominent marginal series.

Hab. Brazil, Castro Paraña (*Jones*). *Exp.* 20 mm.

(2)†SCYBALISTA BIFASCIALIS Wlk. xxvii. 59. Brazil; Peru.
†*Eupoça cinerea* Warr. A. M. N. H. (6) viii. p. 64.

(3)†SCYBALISTA ACUTALIS Warr. A. M. N. H. (6) viii. p. 63. Peru.

(4)†SCYBALISTA SUBDUCTALIS Wlk. xxxiv. 1229. Venezuela.

(5)*SCYBALISTA PRUSALIS Druce, Biol. Centr.-Am., Het. ii. p. 205,
pl. 60. f. 18. Guatemala.

Type. (6) SCYBALISTA RESTIONALIS Led. Wien. Ent. Mon. 1863, p. 455,
pl. 18. f. 15. U.S.A.; Venezuela.

(7)†SCYBALISTA CANALIS Wlk. xxxv. 1717. St. Domingo.

(8) SCYBALISTA SEMIFERREALIS, n. sp.

Head, thorax, and abdomen ferruginous brown and grey. Fore wing ochreous, irrorated and suffused with ferruginous brown; an antemedial grey line with dark outer edge strongly angled below costa; a postmedial grey line with dark inner edge strongly incurved beyond cell; outer area suffused with grey; some ill-defined marginal dark specks with white specks on their inner side towards apex. Hind wing pale, with traces of a curved postmedial line; the outer area suffused with brown; a fine dark marginal line.

Hab. British Guiana; Brazil. *Exp.* 18 mm.

Genus 7. SYMPHYSA, nov.

Palpi upturned, the 1st and 2nd joints with tufts of hair in front, the 2nd not reaching vertex of head, the 3rd well

Fig. 7.

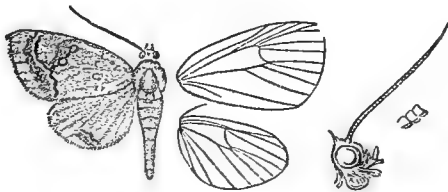

Symphysa sulphuralis, ♂. $\frac{2}{3}$.

developed and acuminate; maxillary palpi long and filiform; frons rounded; antennæ laminate; tibiæ with the outer spurs about hal

the length of inner. Fore wing with vein 3 from close to angle of cell; 4, 5 from angle; 7 straight and well separated from 8, 9; 10, 11 free. Hind wing with vein 3 from angle of cell; 4, 5 approximated for a short distance; 6, 7 from upper angle, 7 anastomosing with 8.

- Type.* (1) *SYMPHYSA SULPHURALIS*, Cram. Pap. Exot. iv. p. 113, pl. 348. E. Brazil.
Pyralis lepidalis, Cram. Pap. Exot. iv. p. 161, pl. 371. K.
 (2) *SYMPHYSA AMENALIS*, Wlk. Trans. Ent. Soc. iii. 1, p. 123. Brazil.
 (3)†*SYMPHYSA ERIPALIS*, Grote, Can. Ent. x. p. 29. U.S.A.
Botys salutalis, Hulst, Tr. Am. Ent. Soc. xiii. p. 150.

Genus 8. MONOCOPTOPERA, nov.

Proboscis well developed; palpi upturned, the 2nd joint reaching well above vertex of head, the 3rd well developed, the 2nd and 3rd joints thickly clothed with scales in female, in male fringed on inner side with long thick hair; maxillary palpi greatly dilated with scales at extremity and nearly as long as the labial; antennæ laminate; tibiæ with the spurs very long; abdomen of male with a collar-shaped ventral valve towards extremity fringed with long curved scales and covering a small white patch. Fore wing with the apex produced into a small lobe, the outer margin excised below it, then greatly excurved at middle; vein 3 from well before angle of cell; 4, 5 from angle; 6 from below upper angle; 7 straight; 8, 9 strongly stalked; 10, 11 from cell. Hind wing with vein 3 from before angle of cell; 4, 5 from angle; 6, 7 from upper angle, 7 anastomosing with 8; the costa of male greatly arched, with a furrow just above cell, a fringe of long hair from medial part of costa, and a tuft of long curved hair towards apex covering a small glandular swelling at apex, all on upperside.

Fig. 8.

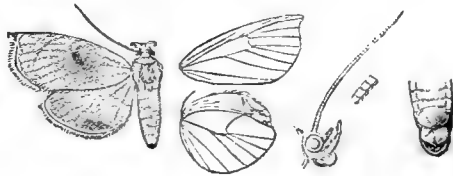

Monocoptopera ecmetallescens, ♂. $\frac{3}{2}$.

Type. MONOCOPTOPERA ECMETALLESCENS, n. sp.

Ochreous white; palpi fulvous. Fore wing with two oblique fulvous strigæ from middle of costa, a diffused fulvous patch below end of cell with short oblique black striga on it: an oblique fulvous striga from costa beyond middle with fulvous beyond it diffused to apex, where there is a small white spot with silvery

outline; the margin purplish silver. Hind wing suffused with fuscous; a broad purplish silver marginal band, with darker mark towards anal angle.

Hab. Amboina. *Exp.* 20 mm. Types in Coll. Rothschild and B.M.

Genus 9. VOLIBA.

Gabrisa Wlk. xxxiv. 1266 (1865), preocc.

Voliba Wlk. xxxv. 1983 (1866).

Stereoscopa Meyr. Trans. Ent. Soc. 1885, p. 448.

Palpi upturned, the 2nd joint not reaching vertex of head and fringed with long hair in front, the 3rd long and acuminate; maxillary palpi short and filiform; frons rounded; antennæ annulate, the basal joint dilated. Fore wing long and narrow; veins 3, 4, 5 from angle of cell; 7 straight and well separated from 8, 9, to which 10 is approximated. Hind wing with the median nervure pectinated above; veins 3, 4, 5 from angle of cell; 6, 7 from upper angle, 7 anastomosing with 8.

Fig. 9.

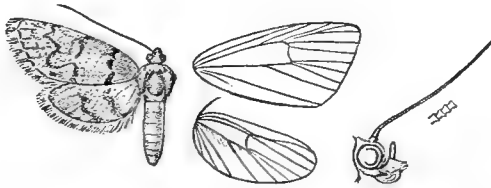

Voliba scoparialis, ♂. $\frac{2}{3}$.

Type. †VOLIBA SCOPARIALIS Wlk. xxxiv. 1266.

Australia.

Genus 10. LIPOCOSMA.

Lipocosma Led. Wien. Ent. Mon. 1863, p. 448.

Palpi upturned, the 1st and 2nd joints with tufts of hair in front, the 2nd hardly reaching vertex of head, the 3rd well developed and acuminate; maxillary palpi small and nearly filiform;

Fig. 10.

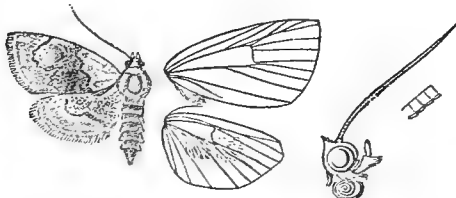

Lipocosma sicalis, ♂. $\frac{2}{3}$.

frons rounded; antennæ laminate; tibiæ with the spurs long and nearly equal. Fore wing with tuft of scales on inner margin near

base; vein 3 from close to angle of cell; 4, 5 from angle; 7 straight and well separated from 8, 9; 10 arising free, then anastomosing with 8, 9, or free. Hind wing with the median nervure pectinated; a tuft of scales on inner area below end of cell; veins 3, 4, 5 from angle of cell; 6, 7 from upper angle; 7 anastomosing with 8.

Type. (1)†*LIPOCOSMA SICALIS* Wlk. xix. 942. U.S.A.
Pyralis perfusalis Wlk. xxxiv. 1226.

(2) *LIPOCOSMA FULIGINOSALIS* Fernald, Ent. Am. iv. p. 37. U.S.A.

(3)†*LIPOCOSMA NIGRIPICTALIS*, n. sp.

♀. White; palpi pale rufous; abdomen with some fuscous on dorsum towards base. Fore wing with oblique subbasal line, the whole area beyond it pale reddish yellow; traces of a waved dark antemedial line; an oblique striga from costa above end of cell; a postmedial dark line excurved from costa to vein 3, then bent inwards and sinuous. Hind wing pale rufous-yellow; a black speck near base of inner area, the tuft of scales below end of cell prominent and black; a postmedial black line, obsolete towards costa, angled inwards on vein 2, and with prominent black band beyond it towards anal angle.

Hab. Espiritu Santo. *Exp.* 16 mm.

Auctorum.

Lipocosma hebescalis Möschl. Abh. Senck. Ges. xvi. p. 316.
Porto Rico.

Genus 11. CATAPSEPHIS, nov.

Palpi upturned, the 3rd joint long and acuminate; maxillary palpi strongly dilated with scales; antennæ laminate; tibiæ with the spurs very long. Fore wing with veins 3, 4, 5 from angle of cell; 7 straight and well separated from 8, 9; 10, 11 stalked. Hind wing with veins 3, 4 from angle of cell; 5 from just above angle; 7 anastomosing with 8.

Fig. 11.

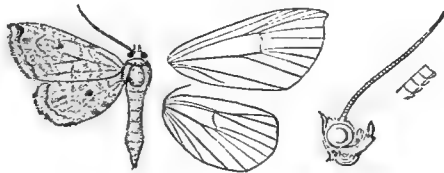

Catapsephis apicipuncta, ♂. $\frac{3}{2}$.

Type. *CATAPSEPHIS APICIPUNCTA*, n. sp.

♂. Head, thorax, and abdomen orange and white; the extremity of 2nd joint of palpi and the maxillary palpi with black rings; fore and mid femora with black points at extremity; wings whitish. Fore wing with the costal area orange; a curved antemedial band;

a black discocellular spot; a postmedial line strongly excurved beyond cell, then retracted to below end of cell, and with diffused orange on its inner side; a broad orange submarginal band; a curved black line just inside margin, bent outwards and expanding into a black spot at apex, and with some fulvous and blackish marks beyond it at middle and outer angle. Hind wing with subbasal orange line; a black discocellular spot; a postmedial orange line retracted at vein 3 to below end of cell; a sinuous submarginal band not reaching anal angle; a sinuous black line just inside margin with some fulvous and black marks beyond it.

Hab. Fergusson I., N. Guinea (*Meek*). *Exp.* 18 mm. Type in Coll. Rothschild.

Genus 12. SUFETULA.

Sufetula Wlk. xix. 946 (1859).

Mirobriga Wlk. xxvii. 131 (1863).

Loetrina Wlk. xxvii. 132.

Pseudochoreutis Snell. Tijds. v. Ent. 1880, p. 202.

Palpi upturned, the 2nd joint moderately scaled and not reaching vertex of head, the 3rd well developed and acuminate; maxillary palpi long and dilated with scales; frons rounded; a tuft of hair between the antennæ, which are annulate; spurs of equal length. Fore wing with the outer margin excised below apex; vein 3 from before angle of cell; 4, 5 from angle; 7 and 10 well separated from 8, 9. Hind wing with vein 3 from before angle of cell; 4, 5 from angle; 6, 7 from upper angle, 7 anastomosing with 8; the outer margin excised below apex and towards anal angle.

Fig. 12.

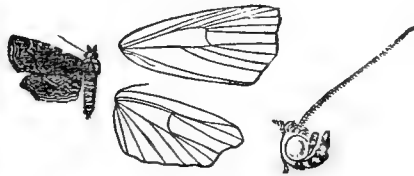

Sufetula sunidesalis, ♂. ♀. (From Moths Ind. vol. iv.)

SECT. I. Palpi of male with the 3rd joint dilated, fringed with long hair on inner side, and recurved over head; maxillary palpi triangularly scaled, with thick hair extending about three times length of head.

(1) SUFETULA MACROPALPIA, n. sp.

Head, thorax, and abdomen fuscous and white; maxillary palpi tinged with ochreous. Fore wing fuscous, with obscure whitish subbasal patch; slight white marks representing the antemedial line; a lunulate medial white patch in and below the cell; two discocellular points; traces of a postmedial line, most distinct towards costa and highly excurved below it; a submarginal

waved line interrupted above and below middle and expanding below the lower gap; a black marginal line interrupted by a white patch below middle. Hind wing with the base white; a broad antemedial white band narrowing to inner margin, where there is a white point inside it; a patch beyond the cell; four submarginal spots; a black marginal line interrupted by patches of white between middle and anal angle; cilia of both wings white.

The type from Fergusson I. has a white spot inside the curve of postmedial line of fore wing, which is wanting in specimens from Amboina and Banda.

Hab. Amboina; Banda; Fergusson I. *Ecp.* 16 mm. Types in Coll. Rothschild and B.M.

SECT. II. Palpi of male normal.

Type. (2) *SUFETULA SUNIDESALIS* Wlk. xix. 947. Sikhim; Assam;
Ceylon; Malayan subregion.

†*Mirobriga albicans* Wlk. xxvii. 132.

†*Loetrina flexalis* Wlk. xxvii. 132.

Pseudochoreutis choreutalis Snell. Tijd. v. Ent. 1880, p. 202, &
1883, pl. 6. f. 8.

(3)†*SUFETULA RECTIFASCIALIS* Hmps. Moths Ind. iv. p. 253.

Ceylon.

(4)†*SUFETULA DIMINUTALIS* Wlk. xxxiv. 1315.

St. Vincent; Honduras.

Hydrocampa dematralis, Druce, Biol. Centr.-Am., Het. ii.
p. 276, pl. 63. f. 25.

(5)†*SUFETULA HEMIOPTHALMA* Meyr. Trans. Ent. Soc. 1884,
p. 286. Australia.

Genus 13. ERPIS.

Erpis Wlk. xxvii. 133 (1863).

Palpi upturned, the 2nd joint not reaching vertex of head, the 3rd well developed and slightly acuminate; maxillary palpi as long as the labial and dilated with scales; antennæ of male thickened.

Fig. 13.

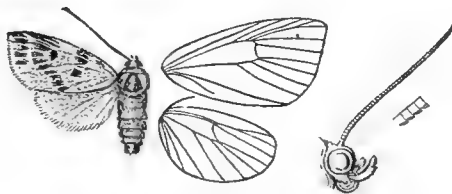

Erpis macularis, ♂. $\frac{3}{2}$.

Fore wing with vein 3 from before angle of cell; 4, 5 from angle; 7 straight and well separated from 8, 9. Hind wing with vein 3

from before angle of cell; 4, 5 from angle; 6, 7 from upper angle, 7 anastomosing with 8.

Type. †*ERPIS MACULARIS* Wlk. xxvii. 133.

Borneo.

Genus 14. *MASSEPHA*.

Massepha Wlk. xvii. 488 (1859).

Palpi upturned, the 2nd joint moderately fringed with scales in front and not reaching vertex of head, the 3rd well developed and acuminate; maxillary palpi minute; frons rounded; antennæ of male annulated; tibiæ with the outer spurs two-thirds length of inner. Fore wing with the apex acute and somewhat produced; veins 3, 4, 5 from angle of cell; 7 well separated from 8, 9, to which 10 is approximated. Hind wing with the cell short; veins 3, 4, 5 from angle; 6, 7 from upper angle, 7 anastomosing with 8.

Fig. 14.

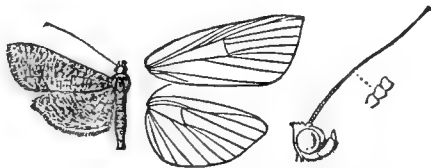

Massepha absolutalis, ♂. †. (From *Moths Ind.* vol. iv.)

SECT. I. Hind wing with the outer margin excised below apex, and three times between vein 5 and anal angle.

(1) *MASSEPHA PHŒNICOBAPTA*, n. sp. (Plate XLIX. fig. 3.)

♂. Head, thorax, and abdomen white mixed with ferruginous red and brown. Fore wing white; the basal area marked with red and brown, except towards costa on which there is a black basal speck followed by a reddish spot; two blackish marks near base of inner margin; an indistinct curved white antemedial line defined towards costa by two black specks on its outer edge; the postmedial area with a triangular red patch from below costa, its apex on vein 1, followed by a large brownish patch with dentate outer edge, its base or inner margin extending from middle to near outer angle, traversed by a sinuous white postmedial line defined by black and excurved at middle, and with some red on its outer side on inner margin; the discocellulars and extremity of median nervure white; a waved black submarginal line with brownish marks beyond it and a black mark at middle. Hind wing with the basal half white mottled with red and brown, bounded by a sinuous white medial line defined by red on inner side, and with a broad diffused area of red shading into brown beyond it; a submarginal red-brown black-defined band running out to the margin at vein 5, then following the margin, and with an apical leaden-grey patch beyond it.

Hab. Fergusson Isl., N. Guinea. *Exp.* 36 mm. Type in Coll. Rothschild.

SECT. II. Hind wing with the outer margin slightly indented below veins 6 and 7.

Type. (2)†MASSEPHA ABSOLUTALIS, Wlk. xvii. 489.

India; Ceylon; Java; Celebes.

Physematia pollutalis Snell. Tijds. v. Ent. xxiii. p. 240, & xxvii. pl. iv. f. 10, 10 a.

(3) MASSEPHA BENGALENSIS Moore, Lep. Atk. p. 211. N.E. India.

(4)*MASSEPHA ENTEPHRIADIA, n. sp.

♀. White; palpi with black spot at end of 2nd joint; thorax and abdomen slightly tinged with fulvous; the latter with a dorsal black point on subterminal segment. Fore wing with the basal area pale fulvous; a black spot near base of costa; a curved pale fulvous antemedial line arising from a black spot on costa; a pale fulvous point in cell and diffused spot on discocellulars; the postmedial line arising from a black point on costa, oblique from costa to vein 2, where it is retracted to below end of cell; terminal area pale fulvous; a black point at apex. Hind wing with traces of antemedial line; a fuscous discoidal point; the terminal half pale fulvous with a fuscous tinge; a postmedial fuscous line bent outwards between veins 5 and 2, then retracted to below end of cell, and defined by white on outer side; both wings with a fulvous line through cilia.

Hab. Warri, Niger. *Exp.* 16 mm. Type in Coll. Rothschild.

(5)†MASSEPHA GRACILIS, n. sp.

♂. White tinged with very pale brown. Fore wing with the basal area, diffused ante- and postmedial bands, and a marginal patch below apex very pale brown; the postmedial band outwardly bounded by a straight line from costa to vein 5. Hind wing with diffused pale brown ante- and postmedial bands and patch on apical area.

Hab. Espiritu Santo. *Exp.* 14 mm.

SECT. III. Hind wing with the outer margin evenly curved.

(6) MASSEPHA CARBONALIS Warr. A. M. N. H. (6) xvii. p. 148.

Assam.

(7)*MASSEPHA GRAMMALIS Guen. Delt. & Pyr. p. 249.

Panama; Cayenne; Brazil.

Botys asiualis Wlk. xviii. 626.

Blepharomastyx romalis Druce, Biol. Centr.-Am., Het. ii. p. 270, pl. 63. f. 4.

(8)†MASSEPHA FULVALIS, n. sp. (Plate XLIX. fig. 2.)

♂. Head, thorax, and abdomen fulvous mixed with black; wings fulvous. Fore wing with some black suffusion at base and on costa; a diffused medial band obtusely angled on median nervure; a lunulate mark beyond the cell extending from costa to

vein 4; a terminal band dentate inwards above vein 5. Hind wing with terminal blackish band and traces of a medial band.

Hab. Brazil, Castro Paraña. *Exp.* 12 mm.

Genus 15. AULACOPTERA.

Aulacoptera Hmps. Moths Ind. iv. p. 254 (1896).

Palpi upturned and slender, the 2nd joint reaching vertex of head, the 3rd long and acuminate; maxillary palpi filiform; frons rounded; antennæ annulate; tibiæ with the outer spurs about two-thirds length of inner. Fore wing with vein 3 from before angle of cell; 4, 5 from angle; 7 straight and well separated from 8, 9, to which 10 is approximated; male with vein 11 curved and running round a furrow of somewhat ribbed membrane below the costa. Hind wing with vein 3 from angle of cell; 4, 5 approximated for a short distance; 6, 7 from upper angle.

Fig. 15.

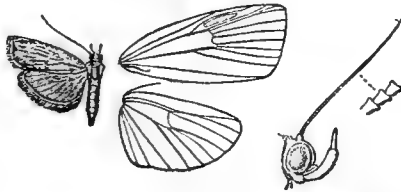

Aulacoptera fuscinevalis, ♂. †. (From Moths Ind. vol. iv.)

Type. AULACOPTERA FUSCINEVALIS Swinh. A. M. N. H. (6) xxi. p. 300.
Assam; Pulo Laut.

Genus 16. XANTHOMELÆNA.

Xanthomelæna, Hmps. Moths Ind. iv. p. 255 (1896).

Palpi upturned, the 2nd joint reaching vertex of head, the 3rd well developed and acuminate; maxillary palpi small and filiform; frons rounded; antennæ of male thickened and flattened; tibiæ with the outer spurs half the length of inner; abdomen long and

Fig. 16.



Xanthomelæna schematias, ♂. †. (From Moths Ind. vol. iv.)

slender, with large protrusible anal tufts. Fore wing long and rather narrow; the cell short; vein 2 from angle; 3 approximated for some distance to 4, 5, which are on a long stalk; 7

curved and approximated to 8, 9; male with a large tuft of scales on underside in end of cell from subcostal nervure met by a slight fringe from median nervure; female with slight fringe from subcostal nervure. Hind wing with the cell short; vein 3 from angle; 4, 5 approximated for some distance; 6, 7 shortly stalked.

Type. XANTHOMELÆNA SCHEMATIAS Meyr. Trans. Ent. Soc. 1894, p. 458.
Burma.

Genus 17. RHIMPHALEODES.

Rhimphaleodes Hmps. Ill. Het. ix. p. 174 (1893).

Palpi upturned, the 2nd joint reaching vertex of head and slightly scaled in front, the 3rd well developed and acuminate; the maxillary palpi filiform; frons rounded; antennæ of male with the basal joint dilated and with tufts of hair from inner side, the shaft minutely ciliated, excised at base, and fringed with scales on inner side for a short distance; tibiæ with the outer spurs short; hind tibiæ of male with a tuft of long scales from extremity, the 1st joint of tarsus fringed with long scales on each side at base. Fore wing with veins 3, 4, 5 well separated at origin; 7 curved and approximated to 8, 9 for some distance; 10 also approximated to 8, 9. Hind wing with veins 3, 4, 5 from angle of cell; 6, 7 from upper angle, 7 anastomosing with 8.

Fig. 17.

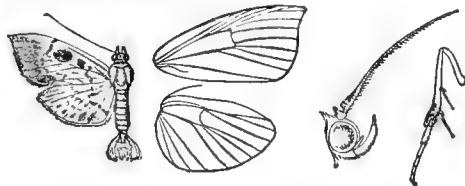

Rhimphaleodes macrostigma, ♂. †. (From Moths Ind. vol. iv.)

Type †RHIMPHALEODES MACROSTIGMA Hmps. Ill. Het. ix. pl. 174. f. 9.
Ceylon; Pulo Laut.

Genus 18. ENTEPHRIA.

Entephria Led. Wien. Ent. Mon. 1863, p. 428.

Pycnarmon Led. Wien. Ent. Mon. 1863, p. 442.

Aripana Moore, Lep. Ceyl. iii. p. 312 (1886).

Satanastra Meyr. Trans. Ent. Soc. 1890, p. 442.

Palpi upturned, the 2nd joint broadly scaled in front and reaching vertex of head, the 3rd long and acuminate; maxillary palpi minute and filiform; frons rounded; tibiæ with the outer spurs about half the length of inner; abdomen with lateral tufts on terminal segments. Fore wing with veins 3, 4, 5 from angle of cell; 7 well separated from 8, 9, to which 10 is approximated.

Hind wing with veins 3, 4, 5 from angle of cell, which is short ;
6, 7 from upper angle, 7 anastomosing with 8.

Fig. 18.

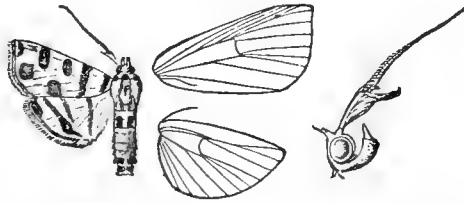

Entephria jaguaralis, ♂. †. (From Moths Ind. vol. iv.)

SECT. I. (*Pycnarmon*). Antennæ of male with the shaft thickened at about one-third length, where there is a cleft fringed with hair on each side.

A. Antennæ of male with a tuft of hair projecting from the upperside of the cleft and diminishing scale-teeth beyond it for a short distance.

- (1) ENTEPHRIA JAGUARALIS Guen. Delt. & Pyr. p. 283.
Himalayas ; Assam ; Malayan
subregion to Solomons.

B. Antennæ of male without tuft of hair from the cleft and scale-teeth beyond it.

- (2)†ENTEPHRIA VIRGATALIS Moore, P. Z. S. 1867, p. 92, pl. 7. f. 9.
Himalayas ; Assam ; Ceylon.
(3)†ENTEPHRIA ABRAXALIS Wlk. xxxiv. 1349. N.E. India.
(4)†ENTEPHRIA RECEPTALIS Wlk. xvii. 473 (♀). Brazil.

SECT. II. (*Entephria*). Antennæ of male simple and ciliated.

A. Fore wing of male below with a fringe of large curved scales in the cell arising from the subcostal nervure.

- (5)†ENTEPHRIA ALBOFLAVALIS Moore, Lep. Atk. p. 220.
Sikhim ; Andamans.

B. Fore wing of male with no fringe of scales in the cell below.

- (6)*ENTEPHRIA DEICONALIS Wlk. xix. 966. Brazil.
(7) ENTEPHRIA DIAPHANA Cram. Pap. Exot. ii. p. 26, pl. 113. f. G.
Zambesi.
(8) ENTEPHRIA CRIBRATA Fabr. Ent. Syst. iii. 2, p. 215 (1794).
Oriental and Australian regions.
Pycnarmon caberalis Guen. Delt. & Pyr. p. 284.

- †*Zebronia abdicalis* Wlk. xvii. p. 480; Led. Wien. Ent. Mon. 1863, pl. 17. f. 12.
Conchylodes corycialis Snell. Tijd. v. Ent. xxiii. p. 238, & xxvii. pl. iv. f. 6.
- (9)†ENTEPHRIA MERITALIS Wlk. xvii. 479. Oriental region;
 †*Zebronia plexippusalis* Wlk. xvii. 485. Australia; Venezuela.
Conchylodes baptalis Snell. Tijd. v. Ent. 1880, p. 238, & 1884, pl. 4. f. 7.
Aripana annulata Warr. A. M. N. H. (6) xviii. p. 168.
- (10)†ENTEPHRIA GLAUCIAS Meyr. Trans. Ent. Soc. 1894, p. 459.
 Pulo Laut.
- (11)†ENTEPHRIA LACTIFERALIS, Wlk. xvii. 480; Hmps. Ill. Het. ix. pl. 173. f. 28. Japan; Oriental region.
 †*Zebronia argyria* Butl. Ill. Het. iii. p. 76, pl. 59. f. 8.
Conchylodes paucipunctalis Snell. Trans. Ent. Soc. 1890, p. 633, pl. xix. f. 2.
- (12)†ENTEPHRIA MACROTIS Meyr. Trans. Ent. Soc. 1897, p. 87.
 Talaut.
- (13)†ENTEPHRIA CERIFERALIS Moore, P. Z. S. 1877, p. 618.
 Andamans.
- (14) ENTEPHRIA RADIATA Warr. A. M. N. H. (6) xviii. p. 169.
 Assam.
- (15) ENTEPHRIA MARGINALIS Snell. Trans. Ent. Soc. 1890, p. 635.
 S. Leone; N.E. India; Malacca.
- (16) ENTEPHRIA IDALIS Wlk. xvii. 485. Borneo; Amboina;
 N. Guinea.
- (17) ENTEPHRIA LEVINIA Cram. Pap. Exot. iv. p. 131, pl. 357. K.
Zebronia bunusalis Wlk. xix. 967. Brazil.
- (18)†ENTEPHRIA NEBULOSALIS Hmps. Journ. Bomb. Nat. Hist. Soc. ined. Ceylon.
- (19)†ENTEPHRIA ARGENTICINCTA, n. sp.
 ♀. White; palpi black above; patagia and basal segment of abdomen with paired black spots; terminal segments of abdomen yellowish, with silvery and black rings, the anal segment with paired black spots. Fore wing with an ochreous tinge; three basal black spots; an antemedial line arising from a black spot on costa: both wings with a prominent discocellular spot; a post-medial line oblique from costa to vein 5, then minutely dentate and at vein 2 retracted to below angle of cell; a marginal orange band, with a black line on its inner edge followed by a white line defined inwardly by fuscous; some marginal black specks.
Hab. New Guinea. *Exp.* 22 mm.
- (20)†ENTEPHRIA PANTHERATA, Butl. Ill. Het. ii. p. 59, pl. 39. f. 4.
 Japan.

(21)†*ENTEPEHRIA DIVARICATA*, n. sp.

Head, thorax, and abdomen pale fulvous and brown; anal tuft with a black band before it and black below in male. Fore wing pale fulvous; two subbasal dark lines; a small annulus in cell with line from it to inner margin; a discocellular reniform spot filled in with fulvous; a postmedial strong black line straight from costa to vein 2, then retracted to angle of cell and irregular, the area beyond it suffused with brown. Hind wing paler, with discocellular annulus; ill-defined postmedial line slightly retracted at vein 2, the area beyond it suffused with brown: both wings with dark marginal line.

Hab. São Paulo (*Jones*). *Exp.* 26 mm.

(22)†*ENTEPEHRIA SYLEPTALIS*, n. sp.

Palpi and frons fuscous, the former with the end of 2nd joint ochreous; head, thorax, and abdomen ochreous tinged with olive, the last with brownish dorsal bands. Fore wing ochreous tinged with olive and irrorated with olive-brown scales; the costal area and a broad terminal area suffused with brown; an antemedial dark line obtusely angled on median nervure; a point in cell and prominent discoidal lunule; the postmedial line marked by points, bent inwards to costa, strongly excurved between veins 5 and 2, then retracted to near angle of cell and bent outwards again; a terminal series of black points. Hind wing whitish; a black discoidal point; the postmedial line very strongly bent outwards between veins 5 and 2; termen suffused with brown; a terminal series of black strigæ; a brown line through cilia.

Hab. Ecuador, Loja. *Exp.* 40 mm.

(23)†*ENTEPEHRIA CROCALIS*, n. sp.

Golden yellow; head and anterior half of thorax purplish fuscous; abdomen tinged with fuscous. Fore wing with the costal half purplish fuscous, its lower edge indented beyond lower angle of cell; a dark point on base of inner margin; an obliquely curved antemedial black line; a discocellular line; a postmedial line obliquely angled below costa, slightly bent inwards below vein 3 and reduced to points; a wedge-shaped yellow mark beyond it on costa. Hind wing with discoidal point; the postmedial line represented by a sinuous series of points excurved beyond cell; a purplish fuscous apical patch.

Hab. Fergusson I., N. Guinea (*Meek*). *Exp.* 22 mm.

Type. (24) *ENTEPEHRIA PRÆRUPTALIS* Led. Wien. Ent. Mon. 1863, p. 428, pl. 16. f. 8. Amboina; Fergusson Island.

Genus 19. *RAVANOVA*.

Ravanoa Moore, Lep. Ceyl. iii. p. 284 (1885).

Palpi obliquely upturned and not reaching vertex of head, the 2nd joint broadly fringed in front, the 3rd well developed and

acuminate; maxillary palpi short and filiform; frons flat and oblique; antennæ of male minutely ciliated; tibiæ with the spurs long and nearly equal. Fore wing with the apex somewhat produced and the outer margin oblique; veins 3, 4, 5 from angle of cell, 7 well separated from 8, 9, to which 10 is approximated. Hind wing with the cell short; veins 3, 4, 5 from angle; 6, 7 from upper angle, 7 anastomosing with 8.

Fig. 19.

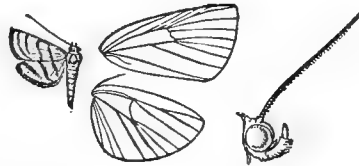

Ravanoa xiphialis, ♂. †. (From Moths Ind. vol. iv.)

Type. RAVANOA XIPHIALIS Wlk. xvii. p. 483.

Ceylon; Burma;
Borneo; Mysol.

†*Zebronia bilineolalis*, Wlk. xxxiv. 1350; Moore, Lep. Ceyl. iii. pl. 180. f. 9.

Genus 20. REHIMENA.

Rehimena Wlk. xxxiv. 1492 (1865).

Cyclarcha Swinh. A. M. N. H. (6) xiv. p. 203 (1894).

Palpi upturned, the 2nd joint slightly fringed in front and not reaching vertex of head, the 3rd well developed and acuminate, longer in female than in male; maxillary palpi well developed and filiform; frons rounded; antennæ of male ciliated; tibiæ with the outer spurs half the length of inner. Fore wing with the apex and outer margin rounded; vein 3 from near angle of cell; 4, 5 from angle; 7 well separated from 8, 9, to which 10 is approximated. Hind wing with vein 3 from angle of cell, which is short and approximated to 4, 5 for a short distance; 6, 7 from upper angle, 7 anastomosing with 8.

Fig. 20.

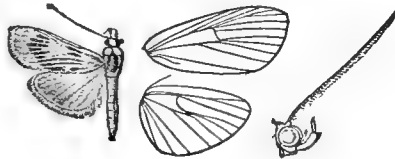

Rehimena striolalis, ♂. †. (From Moths Ind. vol. iv.)

Type. (1)†REHIMENA PHRYNEALIS Wlk. xviii. 630; Moore, Lep. Ceyl. iii. pl. 181. f. 5. India, Ceylon; Burma;

Botys haliusalis Wlk. xviii. 695. Borneo; Sumatra.

†*Rehimena dichromalis* Wlk. xxxiv. 1492.

Botys infundibulalis Snell. Midd.-Sum. p. 64, pl. v. f. 5 (nec 5 a, b).

(2)†*REHIMENA STRIOLALIS* Snell. Trans. Ent. Soc. 1890, p. 604.
N.E. India.

†*Cyclarcha atristrigalis* Swinh. A. M. N. H. (6) xiv. p. 204.

† „ *flavinervis* Swinh. A. M. N. H. (6) xiv. p. 204.

„ *pallidicostalis* Warr. A. M. N. H. (6) xvii. p. 138.

Auctorum.

Rehimena divisa Lucas, P. Linn. Soc. N. S. W. viii. p. 162.

W. Australia.

Genus 21. ZINCKENIA.

Zinckenia Zell. Lep. Caffr. p. 55 (1852).

Hymenia Hübn. Verz. p. 360 (? 1827), non descr.

Spoladea Guen. Delt. & Pyr. p. 224 (1856).

Palpi upturned, the 2nd joint broadly scaled in front and not reaching vertex of head, the 3rd well developed and acuminate; maxillary palpi long and filiform; frons rounded; antennæ of male nearly simple, the base of shaft excised, and a tuft of hair from basal joint; tibiæ with the spurs long and nearly equal. Fore wing with veins 3, 4, 5 from angle of cell; 7 well separated from 8, 9, to which 10 is approximated. Hind wing with vein 3 from angle of cell; 4, 5 approximated for a short distance; 6, 7 from upper angle, 7 anastomosing with 8.

Fig. 21.

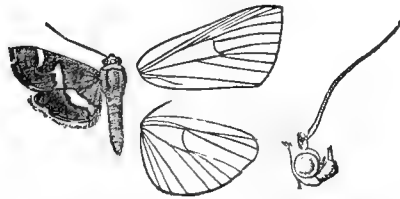

Zinckenia fascialis, ♂. †. (From Moths Ind. vol. iv.)

Type. (1) ZINCKENIA PERSPECTALIS Hübn. Schmett. Eur., Nearctic,
Pyr. f. 101. Neotropical, Ethiopian, &
Australian regions.

Spoladea animalis Guen. Delt. & Pyr. p. 226.

„ *exportalis* Guen. Delt. & Pyr. p. 227.

Zinckenia primordialis Zell. Lep. Caffr. p. 56.

Desmia rhinthonalis Wlk. xix. 932.

Hymenia phrasiusalis Wlk. xix. 944.

(2) ZINCKENIA FASCIALIS Cram. Pap. Exot. iv Neotropical,
pl. 398. f. O. Nearctic, S. Palearctic, Ethiopian,
Oriental, & Australian regions.

Phalœna angustalis Fabr. Mant. Ins. p. 222.

„ *recurvalis* Fabr. Ent. Syst. p. 237.

Hymenia diffascialis Hübn. Verz. p. 361.

Hydrocampa albifascialis Boisd. Faun. Ent. Madag. p. 119,
pl. 16. f. 1.

(3) ZINCKENIA ALIMENALIS Wlk. xvii. 397 (♀). W. Africa.

Auctororum.

- Spoladea spilotalis* Saalm. Ber. Senck. Ges. 1879-80, p. 299. Madagascar.
 „ *avunculalis* Saalm. Ber. Senck. Ges. 1879-80, p. 300. Madagascar.

Genus 22. TABIDIA.

Tabidia Snell. Tijd. v. Ent. 1880, p. 219.

Palpi upturned, the 2nd joint not reaching vertex of head and slightly scaled, the 3rd long and acuminate; maxillary palpi minute and filiform; frons rounded; antennæ of male thickened and flattened, the outer spurs about two-thirds length of inner. Fore wing of male with a recumbent valve of large scales from base of median nervure above; veins 3, 4, 5 well separated at origin; 7 straight and well separated from 8, 9, to which 10 is closely approximated. Hind wing with the cell rather short; veins 3, 4, 5 from angle; 6, 7 from upper angle, 7 anastomosing with 8.

Fig. 22.

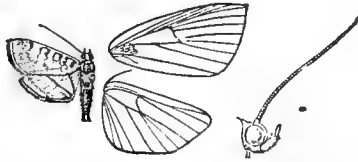

Tabidia aculealis, ♂. †. (From Moths Ind. vol. iv.)

SECT. I. Fore wing with vein 2 arising from near base of median nervure.

- Type.* (1) *TABIDIA INSANALIS* Snell. Tijd. v. Ent. Pulo Laut; Celebes; 1880, p. 220, & 1883, pl. 8. f. 6. Duke of York &
 †*Hydrocampa steniodes*, Butl. A. M. N. H. Shortland Isls. 1882, ii. p. 235.
 †*Hydrocampa felix*, Butl. A. M. N. H. 1887, ii. p. 118.

- (2) †*TABIDIA CRATERODES* Meyr. Trans. Ent. Soc. 1894, p. 467. Pulo Laut; Celebes.

SECT. II. Fore wing with vein 2 arising from middle of cell.

- (3) *TABIDIA ACULEALIS* Wlk. xxxiv. 1427. Ceylon; Pulo Laut; Sula; Celebes.
 †*Isopteryx trisignata* Moore, Lep. Ceyl. iii. p. 306.
 (4) **TABIDIA CANDIDALIS* Warr. A. M. N. H. (6) xviii. p. 169. Assam.
 (5) †*TABIDIA TRUNCATALIS*, n. sp. (Plate XLIX. fig. 5.)

Fuscous; palpi white at base; abdomen with the terminal segment ringed with white and the anal tuft whitish; thorax and abdomen white below. Fore wing with slight pale mark below

base of costa; a nearly straight antemedial dark line defined by whitish on inner side; a white spot below middle of costa, and another below origin of vein 2; two conjoined postmedial white spots from below costa to vein 4 bounded by the sinuous postmedial line, which at vein 4 is retracted to below end of cell. Hind wing with the outer margin truncate from middle to anal angle; a nearly straight oblique medial dark line; cilia of both wings chequered white and fuscous.

Hab. Amboina; Humboldt Bay (*Doherty*) and Fergusson Island, N. Guinea; Queensland (*Meek*). *Exp.* 22 mm.

Auctorum.

Botys defloralis Snell. Tijds. v. Ent. xxvi. p. 130, pl. 7. f. 10.

Java; Celebes.

Genus 23. EURRHYPARODES.

Eurrhyparodes Snell. Tijds. v. Ent. 1880, p. 215.

Molybdanthe Meyr. Trans. Ent. Soc. 1884, p. 309.

Palpi upturned, the 2nd joint broadly scaled in front, the 3rd short and blunt; maxillary palpi nearly as long as the labial and dilated with scales at extremity; frons rounded; antennæ annulated. Fore wing with veins 3, 4, 5 from angle of cell; 7 straight and well separated from 8, 9. Hind wing with the outer margin excised below apex; the cell short; veins 4, 5 approximated for a short distance; 6, 7 from upper angle, 7 anastomosing strongly with 8.

Fig. 23.

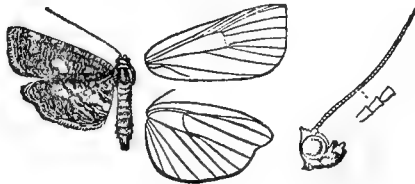

Eurrhyparodes bracteolalis, ♀. $\frac{3}{4}$. (From Moths Ind. vol. iv.)

SECT. I. Fore wing of male with the glandular swelling on costa very large, oval and extending nearly to apex; veins 8, 9 bent downwards; 10, 11 stalked; hind wing with the outer margin deeply excised below apex; fore tibiæ thickly fringed with hair.

(1)*EURRHYPARODES PLUMBEIMARGINALIS, n. sp.

♂. Head fuscous and ochreous; thorax and abdomen fuscous, the latter obscurely ochreous towards base. Fore wing fuscous brown with metallic reflections; an obscure yellow subbasal line, and another yellow line on inner side of the sinuous black antemedial line, which is angled at middle; a yellow mark on discocellulars with a black spot on it; a large yellow patch below end of cell bounded by the yellow postmedial line, which is angled

inwards below costa and sharply outwards on vein 3, then retracted to below end of cell; diffused leaden grey on marginal area; cilia yellowish. Hind wing with the base dark, followed by a large very irregular yellow area with the black discocellular spot on it, and conjoined below the cell to the yellow postmedial line, which is defined on inner side by a black line and bent outwards between veins 5 and 2, with a wedge-shaped dark patch in its sinus; diffused leaden grey on marginal area; cilia yellowish.

Hab. Khasis. *Exp.* 22 mm. Type in Coll. Rothschild.

SECT. II. (*Eurrhyarodes*). Fore wing of male with a large postmedial glandular swelling below costa which is slightly excised towards apex.

- (2) *EURRHYPARODES SPLENDENS* Druce, Biol. Centr.-Am., Het. ii. p. 271, pl. 63. f. 10. Mexico; Centr. Am.

- Type.* (3) *EURRHYPARODES BRACTEOLALIS* Zell. Lep. W. & S. Africa; Caffr. p. 30. Japan; Oriental region; *Isopteryx plumbalis* Guen. Delt. & Pyr. New Hebrides; p. 231. Australia.
 „ *accessalis* Wlk. xvii. 405; Moore, Lep. Ceyl. iii. pl. 179. f. 6.
Eurrhyarodes tibialis Snell. Tijd. v. Ent. 1880, p. 216, & 1883, pl. 8. f. 3.

SECT. III. (*Molybdantha*). Fore wing of male with no postmedial glandular swelling below costa.

- (4) *EURRHYPARODES TRICOLORALIS* Zell. Lep. W. & S. Africa; Caffr. p. 31. Oriental region; *Isopteryx abnegatalis* Wlk. xvii. 404; Australia. Moore, Lep. Ceyl. iii. pl. 179. f. 7.
Eurrhyarodes confusalis Warr. A. M. N. H. (6) xviii. p. 218.
- (5)†*EURRHYPARODES SYLLEPIDIA*, n. sp. (Plate XLIX. fig. 6.)

♀. Head and thorax variegated black-brown and white; abdomen black-brown, the basal half of ventral surface white. Fore wing brown suffused with purplish fuscous except the terminal area below vein 6; a series of white points on costa; the antemedial line oblique sinuous, the postmedial sinuous, bent outwards between veins 5 and 2, then retracted to below end of cell; a semihyaline yellow band between them from subcostals to inner margin; two small spots on inner margin before the antemedial line, a trifid patch in sinus of postmedial line and series of points beyond the line. Hind wing semihyaline yellow, the base black; a black point at lower angle of cell; a dentate fuscous postmedial line bent outwards between veins 5 and 2; an apical black and brown patch and some diffused scales on rest of terminal area; a terminal series of black points.

Hab. Mexico, Guadalajara (*Schaus*). *Exp.* 28 mm.

Genus 24. HETEROCNEPHES.

Heterocnephes Led. Wien. Ent. Mon. 1863, p. 402.

Charitoprepes Warr. A. M. N. H. (6) xvii. p. 136 (1896).

Palpi upturned and reaching vertex of head, the 2nd joint very broadly and quadrately scaled, the 3rd with a long pointed tuft in front; maxillary palpi filiform and long; frons oblique; antennæ of male minutely ciliated and as long as the fore wing; tibiæ with the outer spurs about half the length of inner. Fore wing with the apex somewhat produced and the outer margin oblique; veins 3, 4, 5 from angle of cell; 7 curved and approximated to 8, 9 for about one-third length; 10 also approximated to 8, 9. Hind wing with the cell about half the length of wing; veins 3, 4, 5 from angle; 6, 7 from upper angle, 7 anastomosing with 8.

Fig. 24.

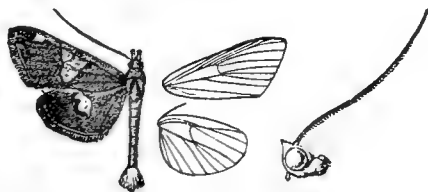

Heterocnephes lymphatalis, ♂. †. (From Moths Ind. vol. iv.)

- Type.* (1) HETEROCNEPHES SCAPULALIS Led. Wien. Ent. Mon. 1863, p. 402, pl. 14. f. 5. Amboina; Solomons.
- (2)† HETEROCNEPHES LYMPHATALIS Swinh. N.E. India; Burma; P. Z. S. 1889, p. 420, pl. 44. f. 7. Malacca; Borneo; Java.
- (3) HETEROCNEPHES LUBRICOSA Warr. A. M. N. H. (6) xvii. p. 136. Assam.

Auctorum.

- Heterocnephes vicinalis* Snell. Midd.-Sum. iv. (1) 8. p. 70. Sumatra.
- „ *atropygialis* Pag. J.B. Nass. Ver. xxxix. p. 171. Aru.
- „ *lunulatis* Pag. J.B. Nass. Ver. xxxix. p. 172. Aru.

Genus 25. AGROTERA.

Agrotera Schrank, Faun. Boica, p. 163 (1798).

Nistra Wlk. xvii. 488 (1859).

Tetracona Meyr. Trans. Ent. Soc. 1884, p. 348.

Sagariphora Meyr. Trans. Ent. Soc. 1894, p. 460.

Palpi upturned and reaching vertex of head, the 2nd joint moderately scaled in front; the 3rd triangularly scaled and set on at an angle; maxillary palpi filiform; frons rounded; antennæ ciliated and annulated; tibiæ with the outer spurs two-thirds length of inner; abdomen long with slight lateral tufts. Fore wing with veins 3, 4, 5 from angle of cell; 7 straight and well

separated from 8, 9, to which 10 is approximated. Hind wing with the cell about half the length of wing; the discocellulars angled; veins 3, 4 from angle; 5 from just above angle; 6, 7 shortly stalked, 7 anastomosing with 8.

Fig. 25.

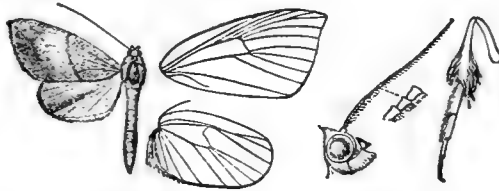

Agrotera magnificentalis, ♂. †. (From Moths Ind. vol. iv.)

SECT. I. (*Sagariphora*). Hind tibiae of male with tufts of long hair at extremity on inner and outer sides, the tarsus fringed with hair on outer side.

A. Hind wing with fringe of long hair on inner area below.

(1)†*AGROTERA MAGNIFICALIS* Hmps. Ill. Het. ix. p. 173, pl. 174. f. 17.

Ceylon; Sumbawa.

†*Sagariphora heliochaena* Meyr. Trans. Ent. Soc. 1894, p. 461.

B. Fore wing with hyaline fovea below base of cell.

(2)**AGROTERA SETIPES*, n. sp.

♂. Pale purplish fuscous; tegulae, patagia, and base of abdomen pale yellow spotted with orange-red. Fore wing with the base marked with yellow and red; a pale yellow subbasal band with wavy edges, defined by black towards costa, and irrorated with red especially on its edges; a slight black discocellular lunule with small red spot on its outer edge; a postmedial dark line nearly straight from costa to vein 3, then retracted to below end of cell and angled outwards above vein 2. Hind wing with yellow and red patch below end of cell; a postmedial line excurved beyond angle of cell, then retracted and excurved again: both wings with fine marginal black line.

Hab. Bungurau, Natuna Is. (*Hose*). *Exp.* 22 mm. Type in Coll. Rothschild.

SECT. II. (*Agrotera*). Hind legs and hind wing normal.

(3)†*AGROTERA SCISSALIS* Wlk. xxxiv. 1526.

N.E. India; Ceylon; Burma; Java.

(4)†*AGROTERA EFFERTALIS* Wlk. xvii. 348; Ceylon; Perak; Hmps. Ill. Het. ix. pl. 174. f. 19. Celebes.

(5)**AGROTERA ENDOXANTHA*, n. sp. (Plate XLIX. fig. 26.)

♀. Head, thorax, and abdomen pale yellow marked with orange-red; palpi and last segment of abdomen fuscous; legs banded

with fuscous. Fore wing with the basal area fuscous spotted with orange-red, its outer edge obliquely curved and with traces of a black line; an oblique black striga on costa; the rest of wing dull purplish; a black discocellular lunule with bidentate yellow spot edged by red on its outer side; the postmedial black line angled outwards below costa and at vein 4, then retracted to below end of cell and excurved again, and with a series of red-edged yellow spots on its outer edge; a black marginal line; cilia chequered black and yellow. Hind wing with the basal and inner areas pale yellow; a red spot below the cell and streak on vein 1; the apical third of wing purplish, defined on inner side by a red line and black point, and crossed by a black postmedial line with red and yellow on its outer edge and tridentate beyond lower angle of cell; a fine black marginal line; cilia yellow, dark at apex and middle.

Hab. Humboldt Bay, N. Guinea (*Doherty*). *Exp.* 24 mm. Type in Coll. Rothschild.

(6)†*AGROTEBA FUMOSA*, n. sp.

Differs from *effertalis* in the male having a white patch on anal segment above. Fore wing with the outer edge of basal area more erect and slightly angled inwards on vein 1; a black discocellular lunule instead of the yellow and orange patch. Hind wing with smaller basal yellow patch with no orange on it.

Hab. Accra; Aburi, W. Africa. *Exp.*, ♂ 26, ♀ 20 mm.

(7)†*AGROTERA CITRINA*, n. sp.

Differs from *fumosa* in the anal segment of abdomen being dark. Fore wing with a small orange speck beyond the dark discocellular line; the outer part of costa with an orange fascia and some orange beyond the postmedial line, which is much less retracted at vein 2. Hind wing with straight prominent black postmedial line between veins 7 and 2, with orange-red on its outer edge.

Hab. Accra, W. Africa. *Exp.* 18 mm.

(8)†*AGROTERA BASINOTATA* Hmps. Ill. Het. viii. p. 137, pl. 155.
f. 13. India, Ceylon, & Burma.

(9)†*AGROTERA DISCINOTATA* Swinh. A. M. N. H. (6) xiv. p. 207.
N.E. India.
,, *griseola* Warr. A. M. N. H. (6) xvii. p. 139.

(10)**AGROTERA IGNEPCTA*, n. sp.

♀. Head, thorax, and abdomen yellow variegated with fiery red; antennæ dark; abdomen with slight dorsal segmental black lines and the extremity purplish; wings pale purplish. Fore wing with the basal area yellow variegated with fiery red and with traces of subbasal dark line and waved antemedial line; a large somewhat bidentate yellow-and-red patch beyond the cell defined by dark scales, and with some diffused brown with two red points on it below it; a minutely crenulate postmedial line angled below costa

and at vein 3 retracted to below end of cell. Hind wing with the inner area yellow variegated with red to the postmedial line, which is represented by points from costa to vein 3, where it is retracted, then developed into more prominent spots towards inner margin; a discocellular point and slight brown suffusion beyond lower angle of cell.

Hab. Cedar Bay, Cooktown, Queensland (*Meek*). *Exp.* 26 mm. Type in Coll. Rothschild.

- Type.* (11) *AGROTERA NEMORALIS* Scop. Ent. Carn. p. 242. Europe;
Phalena erosalis Fabr. Ent. Syst. no. 405. Japan; China.
- (12)† *AGROTERA AMATHEALIS* Wlk. xvii. 348. Australia.
 † *Pyralis ornatalis* Wlk. xxxiv. 1246.
- (13) *AGROTERA PICTALIS* Warr. A. M. N. H. (6) xvii. p. 139. Australia.
- (14)† *AGROTERA CELATALIS* Wlk. xvii. 488; Moore, Lep. Ceyl. iii. pl. 182. f. 10. Ceylon; Borneo;
Botys proximalis Wlk. xxxiv. 1434. Sumbawa; Celebes.
- (15)† *AGROTERA LEUCOSTOLA* Hmps. Moths Ind. iv. p. 268. Sikhim; Assam.
- (16) *AGROTERA BARCEALIS* Wlk. xix. 942. Ceylon; Sumatra;
Zebronia retractalis Wlk. xxxiv. 1350. Borneo; Mysol.
 „ *indecisalis* Wlk. xxxiv. 1352.
Leucinodes opalina Moore, Lep. Ceyl. iii. p. 289, pl. 179. f. 10.

Auctorum.

- Agrotera fenestralis* Christ. Bull. Mosc. lvi. (1) p. 39. Amur.
 „ *retinalis* Saalm. Ber. Senck. Ges. 1879, p. 304. Madagascar.
- Rhodaria olivacealis* Brem. Mém. Acad. St. Pétersb. viii. p. 66, pl. 6. f. 2. Siberia.

Genus 26. *DESMIA*.

- Desmia* Westw. Mag. Zool. ix. (1831).
Ædiodes Guen. Delt. & Pyr. p. 191 (1854).
Arna Wlk. viii. 75 (1856).

Palpi upturned, the 2nd joint moderately scaled in front, the

Fig. 26.



Desmia funeralis, ♂. †.

3rd with a short triangular tuft; maxillary palpi small and filiform;

frons rounded; antennæ ciliated; tibiæ with the outer spurs short; abdomen long in male. Fore wing with the apex produced and the outer margin oblique; veins 3, 4, 5 from angle of cell; 7 somewhat curved and approximated to 8, 9, to which 10 also is approximated. Hind wing with the basal half of costa much arched; veins 3, 4, 5 approximated for some distance; 6, 7 from upper angle, 7 anastomosing with 8 to three-fourths of wing.

SECT. I. (*Desmia*). Antennæ of male with the shaft excised at middle and with a tuft of scales before the excision.

Type. (1) *DESMIA FUNERALIS* Hübn. Pyr. f. 103. U.S.A.
 „ *maculalis* Westw. Mag. Zool. ix. pl. 2.
 „ *subdivisalis* Grote, Can. Ent. iii. p. 126.

(2) *DESMIA TAGES* Cram. Pap. Exot. ii. p. 2, pl. 97. f. D. W. Indies; Brazil.
Hyalitis tagesalis Guen. Delt. & Pyr. p. 291.
Desmia propinqualis Müschl. Surinam, p. 430, pl. 18. f. 37.

(3) *DESMIA GEMINALIS* Snell. Tijd. v. Ent. 1875, p. 249, pl. xiv. f. 5. Colombia; Peru.

(4)†*DESMIA CERESALIS* Wlk. xvii. 339. Jamaica.

(5)†*DESMIA PENTODONTALIS*, n. sp.

Black-brown with a cupreous tinge; palpi white below; abdomen tinged with white. Fore wing with a hyaline spot in cell; a lunulate spot in end of cell, extending to costa and conjoined to a lunulate spot below the cell which has a whitish mark below it; a postmedial hyaline band from costa to vein 3 with 5 dentitions on its outer edge with a line beyond them, at vein 3 becoming an obliquely sinuous line. Hind wing with very irregular medial hyaline band conjoined at lower angle of cell to an irregular postmedial line arising from an apical patch; cilia whitish.

Hab. Ecuador (*Abbé Gaujon*). *Exp.* 34 mm.

SECT. II. Antennæ of male slightly excised at middle and without tuft of scales.

(6) *DESMIA UFEUS* Cram. Pap. Exot. ii. p. 2, pl. 97. f. E. W. Indies; Brazil.
Ædiodes orbalis Guen. Delt. & Pyr. p. 192 (var.).

†*Desmia prognealis* Wlk. xvii. 346.

„ *bulisalis* Wlk. xix. 928.

† „ *divisalis* Wlk. xxxiv. 1292.

(7)**DESMIA INTERMICALIS* Guen. Delt. & Pyr. p. 192 (♀). Mexico; Brazil.

SECT. III. Antennæ of male thickened at one-third and fringed with spines above; patagia with very long tufts of hair; fore wing with the base of inner margin lobed and clothed with black scales; hind wing with the inner margin immensely lobed and thickly clothed with black hair.

- (8) *DESMIA BAJULALIS* Guen. Delt. & Pyr. p. 291. Brazil.
Glyphodes dermatalis Feld. Reis. Nov. pl. 136. f. 23.

SECT. IV. Antennæ of male normal.

A. Hind wing of male with a fold on inner area containing flocculent hair below.

- (9)†*DESMIA DISCREPANS* Butl. A. M. N. H. 1887, ii. p. 117. Solomons.

B. Hind wing of male with a fold at upper angle of cell.

- (10)**DESMIA PISUSALIS* Wlk. xix. 927. Brazil.

C. (*Ædiodes*). Hind wing of male normal.

- (11) *DESMIA FUNEBRALIS* Guen. Delt. & Pyr. p. 189. S. America.
„ *notalis* Feld. Reis. Nov. pl. 136. f. 4.
Hyalea melanalis Feld. Reis. Nov. pl. 135. f. 16.

- (12)†*DESMIA PAUCIMACULALIS*, n. sp.
„ *sepulchralis* Warr. Tr. Ent. Soc. 1889, p. 270 (nec Guen.).

♂. Black. Fore wing with small subtriangular hyaline spot in cell and elongate wedge-shaped bar beyond the cell. Hind wing with oblique antemedial hyaline band, not reaching costa, broadening at median nervure and narrowing to a point at inner margin.

Hab. Amazons (*Trail*). *Exp.* 24 mm.

- (13)†*DESMIA EXTREMA* Wlk. viii. 75. Brazil.

- (14) *DESMIA FLORALIS* Guen. Delt. & Pyr. p. 192. W. Indies; Brazil.

- (15)**DESMIA SEPULCHRALIS* Guen. Delt. & Pyr. p. 190. Trinidad; Brazil.

- (16) *DESMIA STRIGIVITRALIS* Guen. Delt. & Pyr. p. 193. Venezuela; Brazil.

- (17)†*DESMIA MELALEUCALIS*, n. sp. (Plate XLIX. fig. 27.)

♀. Purplish black; palpi at base, pectus, and patches on coxæ white; abdomen blue-black, the first segment with white band, the next two slightly edged with white, the basal half of ventral surface white. Fore wing with short irregular hyaline streak below base of cell; a somewhat triangular spot in end of cell; a slight discoidal lunule; points above and below base of vein 2 with a striga beyond them; a band beyond the cell between veins 7 and 3, expanding below vein 5, and with two small detached spots

beyond its lower extremity between veins 2 and 4. Hind wing hyaline white; the base, costa, and terminal area irregularly purplish black, the costal fascia emitting a tooth on discocellulars and encroached on by a spot above middle of vein 6; the terminal band quadrately excised between veins 5 and 2, with a striga between veins 3 and 2; black points at lower angle of cell and on middle of vein 1.

Hab. Ecuador, Loja. *Exp.* 30 mm.

(18)†*DESMIA ODONTOPLAGA*, n. sp.

♂. Head blackish; palpi white below; thorax and abdomen brownish. Fore wing fuscous brown with a cupreous tinge; an elliptic white spot in and below middle of cell, with a speck beyond its lower point and obscure line from it to inner margin; a white postmedial patch between veins 2 and 5 conjoined to two small spots between it and costa. Hind wing with large medial white patch not reaching costa and inner margin, its outer side expanding and minutely dentate below vein 5; cilia of both wings white at tips.

Hab. Paraña, Lower Amazons (*Austen*). *Exp.* 20 mm.

(19)†*DESMIA CHRYSEIS*, n. sp. (Plate XLIX. fig. 28.)

♂. Orange-yellow; anal tuft large, with some leaden scales. Fore wing with the base of costa and antemedial line purplish fuscous, the latter obsolescent below vein 1; a point in cell and discoidal line; the terminal third purplish fuscous except on costa, its inner edge rather sinuous. Hind wing with obscure discoidal point and oblique postmedial line; a purplish-fuscous band on termen, broad at costa, narrowing to a point above tornus.

Hab. Aroa, Venezuela; Peru. *Exp.* 32 mm.

Auctorum.

Ædiodes flebilialis Guen. Delt. & Pyr. p. 191. Cayenne.

Desmia nachialis Snell. Tijd. v. Ent. 1875, p. 250, pl. xiv. ff. 6, 7. W. Indies.

„ *jovealis* Snell. Tijd. v. Ent. 1875, p. 252, pl. xiv. ff. 8, 9. W. Indies.

Ædiodes orientalis Snell. Tijd. v. Ent. xxiii. p. 233, & xxvii. pl. iv. ff. 3, 3a. Celebes.

De ia viduatalis Möschl. Abh. Senck. Ges. xvi. p. 311. Porto Rico.

Ædiodes unipunctalis Druce, Biol. Centr.-Am., Het. ii. p. 261, pl. 62. f. 26. Panama.

Genus 27. *ÆTHOLIX*.

Ætholia Led. Wien. Ent. Mon. 1863, p. 437.

Palpi upturned and reaching vertex of head, the 2nd joint moderately scaled, the 3rd with a short triangular tuft in front; maxillary palpi filiform; frons rounded; antennæ slightly longer than the fore wing and ciliated; tibiæ with the outer spurs about

two-thirds length of inner; thorax with ridges of large flattened scales below; abdomen rather long, with lateral tufts. Fore wing narrow; the apex produced and the outer margin oblique; veins 3, 4, 5 from angle of cell; 7 curved and approximated to 8, 9, to which 10 also is approximated. Hind wing with the cell short; the discocellulars straight; veins 3, 4 from angle and approximated for a short distance; 5 from just above angle; 6, 7 from upper angle, 7 anastomosing with 8; the costal nervure and costa much arched at middle.

Fig. 27.



Ætholix flavibasalis, ♂. ♀. (From Moths Ind. vol. iv.)

Type. (1) *ÆTHOLIX FLAVIBASALIS* Guen. Delt. & Pyr. p. 193; Led. Wien. Ent. Mon. 1863, pl. 17. f. 6. W. India; Ceylon;

Andamans; Borneo.

†*Ætholix cingalesa* Hmps. Ill. Het. ix. p. 173, pl. 174. f. 18.

(2)**ÆTHOLIX INDECISALIS*, Warr. A. M. N. H. (6) xvii. p. 148.

Assam.

Genus 28. PAGYDA.

Pagyda Wlk. xvii. 487 (1859).

Synclera Led. Wien. Ent. Mon. 1863, p. 444.

Palpi upturned and reaching vertex of head, the 2nd joint very broadly and quadrately scaled in front, the 3rd short with a long pointed tuft in front; maxillary palpi filiform; frons rounded; antennæ annulated with rings at the joints; tibiæ smoothly scaled, the spurs nearly equal except the outer medial spur of hind tibiæ,

Fig. 28.

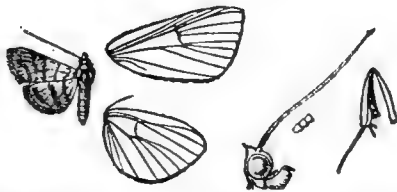

Pagyda salvatis, ♂. ♀. (From Moths Ind. vol. iv.)

which is about one half the length of inner. Fore wing with veins 3, 4, 5 from angle of cell; 6 from well below upper angle; 7 straight and well separated from 8, 9, to which 10 is approximated. Hind wing with the cell short; vein 3 from angle; 4, 5 approximated for a short distance or well separated; 6, 7 from upper angle, 7 anastomosing with 8.

SECT. I. (*Pagyda*). Mid tibiæ of male with a fold containing a tuft of long hair.

- (1) *PAGYDA AURORALIS* Moore, Lep. Atk. p. 215, pl. 7. f. 17.
N.E. India; Burma.
† „ *rubricatalis* Swinh. Trans. Ent. Soc. 1890, p. 282.

Type. (2)†*PAGYDA SALVALIS* Wlk. xvii. 487; Moore, Lep. Ceyl. iii. pl. 182. f. 6. Japan; India, Ceylon, & Burma;
†*Botys arbiter* Butl. Ill. Het. p. 77, pl. 59. f. 13. Borneo.

- (3)**PAGYDA SCHALIPHORA*, n. sp.

♀. Pale yellowish, palpi and first segment of abdomen tinged with orange. Fore wing with slightly curved orange antemedial line; a line on discocellulars met at lower angle of cell by a curved postmedial line arising from a black point on costa, then continued to inner margin, then forming a fork, the area beyond it suffused with pinkish; an indistinct sinuous submarginal line. Hind wing with curved oblique antemedial line, broad oblique postmedial line, and submarginal line from costa to vein 2; the area beyond the antemedial line below vein 2 and between the postmedial and submarginal lines suffused with pinkish; both wings with fine orange marginal line and line through the cilia.

Hab. Cedar Bay, Cookstown, Queensland (*Meek*). *Exp.* 22 mm.
Type in Coll. Rothschild.

- (4) *PAGYDA CALIDA*, n. sp.

Deep brownish orange; legs striped with white; abdomen with white dorsal lines on last two segments, followed by a pair of black points, a white spot and lateral white streaks on the anal tuft. Fore wing with curved antemedial line; a postmedial line oblique from costa to vein 3, where it is sharply angled and retracted to below end of cell, both lines arising from black points on costa; two black discoidal points; an indistinct submarginal line bent inwards to costa. Hind wing with broad oblique ante- and postmedial lines running to near anal angle, the latter met at vein 2 by the submarginal line; both wings with fine dark marginal line and orange line through the cilia.

Hab. Padang Rengas, Malay Peninsula; Baram, Borneo (*Everett*). *Exp.* 24 mm. *Types* in Coll. Rothschild and B.M.

- (5)†*PAGYDA DISCOLOR* Swinh. A. M. N. H. (6) xiv. p. 197.
Assam; Burma.

- (6) *PAGYDA BOTYDALIS* Snell. Tijd. v. Ent. 1880, p. 69, & Midd.-Sum. pl. v. f. 9. N.E. India; Ceylon;
†*Pagyda aurantialis* Hmps. Ill. Het. ix. Sumatra; Borneo.
p. 169, pl. 173. f. 17.

- (7)†*PAGYDA ARGYRITIS* Hmps. Journ. Bomb. Nat. Hist. Soc. ined. Sikhim.

- (8)†*PAGYDA AMPHISALIS* Wlk. xviii. 661. Japan; China; Assam.

- (9)†PAGYDA QUADRILINEATA Butl. Trans. Ent. Soc. 1881, p. 586.
Japan.
- (10)†PAGYDA PEASALIS Wlk. xviii. 717. Borneo.
- (11)*PAGYDA LUSTRALIS Snell. Trans. Ent. Soc. 1890, p. 615.
N.E. India; Burma.
- (12)*PAGYDA EXALBALIS Hmps. Moths Ind. iv. p. 271. Burma.
- (13)†PAGYDA FULVISTRIGA Swinh. A. M. N. H. (6) xiv. p. 206 (♀).
Assam.
- (14)†PAGYDA CARITALIS Wlk. xviii. 789 (♀). W. Africa.
- (15)†PAGYDA PARAPHRAGMA Meyr. Trans. Ent. Soc. 1889, p. 157.
New Guinea.

SECT. II. (*Synclera*). Mid tibiæ of male not dilated.

- (16)†PAGYDA TRADUCALIS Zell. Lep. Caffr. p. 54; Moore, Lep. Ceyl. iii. pl. 182. f. 9. Neotropical & Ethiopian regions; Palestine; India, Ceylon, & Burma.
Spilomela retinalis Led. Wien. Ent. Mon. 1857, p. 100.
†*Samea jarbusalis* Wlk. xvii. 352.
†*Glyphodes univocalis* Wlk. xvii. 499.
†*Zebronia cottalis* Wlk. xix. 964.
†*Samea chlorophasma* Butl. P. Z. S. 1878, p. 493.
- (17)†PAGYDA SUBTESSELLALIS Wlk. xxxiv. 1406.
N.E. India; Burma.
- (18)†PAGYDA STRAMINEALIS Hmps. Moths Ind. iv. p. 273.
Sikhim.
- (19)†PAGYDA ERYTHRIAS Meyr. Trans. Ent. Soc. 1894 p. 457 (mid tibiæ wanting). Celebes.

Auctororum.

Synclera prælatalis Möschl. Abh. Senck. Ges. xiv. p. 81.

Jamaica.

Genus 29. ERCTA.

Ercta Wlk. xvii. 425 (1859).

Spanista Led. Wien. Ent. Mon. 1863, p. 445 (preocc.).

Hydriris Meyr. Trans. Ent. Soc. 1863, p. 445.

Palpi upturned and reaching vertex of head, the 2nd joint broadly scaled in front, the 3rd with a short triangular tuft of scales in front; maxillary palpi extremely minute; frons rounded; antennæ long and annulated; tibiæ with the outer spurs about half the length of inner; abdomen of male long, with a trifid anal tuft. Fore wing with the costa arched towards apex, which is produced; the outer margin excurved at middle; veins 3, 4, 5 from close to angle of cell; 7 straight and well separated from 8, 9, to which both 10 and 11 are closely approximated. Hind wing with the outer margin somewhat excurved at middle; veins

3, 4, 5 from angle of cell; 6, 7 from upper angle, 7 anastomosing with 8.

Fig. 29.

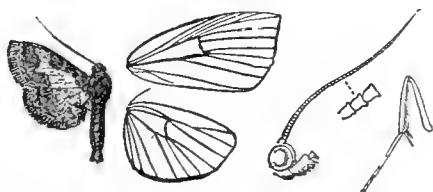

Ercta elutalis, ♂. $\frac{1}{2}$. (From Moths Ind. vol. iv.)

SECT. I. Mid tibiæ of male dilated with a fold containing a ridge of hair.

- (1) †*ERCTA ELUTALIS* Wlk. xvii. 448. S. India; Ceylon;
 †*Pyralis aonisalis* Wlk. xix. 911. Borneo; Celebes.
Botys bornealis Feld. Reis. Nov. pl. 135. f. 27.
Spanista pretiosalis Snell. Tijd. v. Ent. 1880, p. 239, & 1884,
 pl. 4. ff. 9, 9 a.

SECT. II. Mid tibiæ with no dilation or fold.

- (2) *ERCTA ORNATALIS* Dup. Lép. France, vii. p. 207, pl. 223. f. 8.
 S. Nearctic, Neotropical, & Ethiopian regions;
Botys saturalis Treit. Schmett. Eur. S. Europe; the Oriental
 x. 3. 29. & Australian regions.
 †*Pyralis deciusalis* Wlk. xix. 905.
Botys invenustalis Wlk. xxxiv. 1431.
 †*Cataclysta fraterna* Butl. A. M. N. H. 1875, ii. p. 415.

- (3) *ERCTA CHALYBITIS* Meyr. Trans. Ent. Soc. 1885, p. 444.
 New Hebrides; Tonga.

- Type.* (4) *ERCTA VITTATA* Fabr. Ent. Syst. iii. 2, p. 217. W. Indies.
 „ *hemialis* Guen. Delt. & Pyr. p. 248.
 † „ *tiputalis* Wlk. xvii. 426.

Auctorum.

- Hydriris angustalis* Snell. Tijd. v. Ent. xxxviii. p. 154. Java.

Genus 30. CNAPHALOCROCIS.

Cnaphalocrocis Led. Wien. Ent. Mon. 1863, p. 384.

Palpi upturned, the 2nd joint broadly scaled in front, the 3rd with a short triangular tuft; maxillary palpi filiform; frons flat and oblique; antennæ annulated; tibiæ with the outer spurs half the length of inner. Fore wing with veins 3, 4, 5 from angle of cell; 7 straight and well separated from 8, 9; 10, 11 stalked; male with erect triangular tuft of hair on upperside from subcostal and median nervures at middle of cell, with a depression of the wing-membrane between them and downwardly directed post-medial tuft from costa. Hind wing with the cell short; veins 3,

4, 5 from angle; 6, 7 from upper angle, 7 anastomosing with 8 almost to apex.

Fig. 30.

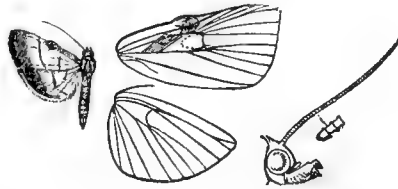

Cnaphalocrocis medinalis, ♂. †. (From Moths Ind. vol. iv.)

- Type.* CNAPHALOCROCIS MEDINALIS Guen. Delt. & Pyr. p. 201. Japan;
 † *Botys rutilalis* Wlk. xviii. 665. Oriental & Australian regions.
 † „ *iolealis* Wlk. xviii. 666; Led. Wien. Ent. Mon. 1863,
 pl. 12. f. 7.
 † „ *nurscialis* Wlk. xviii. 724 (subsp.).
 „ *fasciculatalis* Wlk. xxxiv. 1431.
 † „ *acerrimalis* Wlk. xxxiv. 1449.

Genus 31. MARASMIA.

Marasmia Led. Wien. Ent. Mon. 1863, p. 385.

Dolichosticha Meyr. Trans. Ent. Soc. 1884, p. 304.

Epimima Meyr. Trans. Ent. Soc. 1886, p. 235.

Lasiacme Warr. A. M. N. H. (6) xviii. p. 176 (1896).

Palpi upturned, the 2nd joint broadly scaled in front, the 3rd with a short triangular tuft; frons flat and oblique; antennæ annulated; tibiæ with the outer spurs half the length of inner. Fore wing with veins 3, 4, 5 from angle of cell; 7 straight and well separated from 8, 9, to which 10 is closely approximated. Hind wing with the cell short; veins 3, 4, 5 from angle; 6, 7 from upper angle, 7 anastomosing with 8 almost to apex.

Fig. 31.

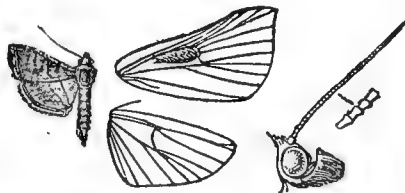

Marasmia veniialis, ♂. †. (From Moths Ind. vol. iv.)

SECT. I. (*Marasmia*). Fore wing of male with a very large tuft of long flattened leaden-coloured scales on upperside from below middle of costa, extending across the cell and covering a vesicular fold in end of cell.

- Type.* (1) † MARASMIA VENILIALIS Wlk. xvii. 373. W. & S. Africa;
 † *Botys ruralis* Wlk. xviii. 666. Oriental & Australian
 † „ *marisalis* Wlk. xviii. 717. regions to Fiji.

Marasmia cicatricosa Led. Wien. Ent. Mon. 1863, p. 386,
pl. 12. f. 8.

Lasiacme mimica Warr. A. M. N. H. (6) xviii. p. 177.

(2) MARASMIA HEMICROSSA Meyr. Trans. Ent. Soc. 1887, p. 217
(♀). Fiji.

(3)† MARASMIA LATIMARGINALIS Hmps. Ill. Het. viii. p. 138,
pl. 155. f. 15. N.E. & S. India.
Lasiacme pilosa Warr. A. M. N. H. (6) xviii. p. 176.

SECT. II. (*Epimima*). Fore wing of male without the fold and tuft
below costa.

A. Maxillary palpi filiform; fore wing short.

(4) MARASMIA TREBIUSALIS Wlk. xviii. 718. W. Africa; India;
Asopia socialis Wlk. xxxiv. 1306. Ceylon; Borneo;
Epimima stereogona Meyr. Trans. Ent. Soc. Flores; Fiji.
1886, p. 236.

(5)† MARASMIA BILINEALIS Hmps. Ill. Het. viii. p. 139, pl. 155.
f. 25. Assam; S. India; Ceylon; Borneo.
Dolichosticha subauralis Warr. A. M. N. H. (6) xviii. p. 175.

B. Maxillary palpi triangularly dilated with scales; fore wing
rather more produced at apex.

(6)† MARASMIA COCHRUSALIS Wlk. xix. 959. U.S.A.; W. Indies;
Botys azionalis Wlk. xix. 985. S. America.
† „ *ruptalis* Wlk. xxxiv. 1391.

(7) MARASMIA TRAPEZALIS Guen. Delt. & Pyr. Neotropical,
p. 200. Ethiopian, Oriental, &

† *Botys creonalis* Wlk. xviii. 579; Moore, Australian regions.
Lep. Ceyl. iii. pl. 180. f. 10.

† „ *neoclesalis* Wlk. xviii. 635.

† „ *suspicalis* Wlk. xviii. 667.

† „ *convectalis* Wlk. xxxiv. 1411.

Cnaphalocrocis bifurcalis Snell. Tijd. v. Ent. 1880, p. 219, &
1883, pl. 8. f. 5.

Dolichosticha perinephes Meyr. Trans. Ent. Soc. 1887, p. 236
(subsp.).

(8)† MARASMIA FUSCIFASCIALIS Hmps. Moths Ind. iv. p. 277.
Ceylon.

(9)† MARASMIA EXIGUA Butl. A. M. N. H. 1879, ii. p. 453 (♀).
Japan.

Auctorum.

Marasmia aurea Druce, P. Z. S. 1888, p. 230. Fiji.

Cnaphalocrocis sanitalis Snell. Midd.-Sum. iv. (1) 8. p. 65.

Sumatra.

- Cnaphalocrocis perpersalis* Möschl. Abh. Senck. Ges. xvi. p. 293.
Porto Rico.
,, *similis* Hedemann, Stett. Ent. Zeit. lv. p. 287.
St. Croix.
Dolichosticha subvenialis Snell. Tijd. v. Ent. xxxviii. p. 124.
Java.
Auxomitia minoralis Snell. Tijd. v. Ent. xxiii. p. 222, & xxvi.
pl. viii. ff. 5, 5 a. Java.

Genus 32. RHIMPHALEA.

Rhimphalea Led. Wien. Ent. Mon. 1863, p. 410.

Palpi upturned, the 2nd joint broadly fringed in front, the 3rd short and blunt with a small triangular tuft in front; maxillary palpi well developed and filiform; frons flat and oblique; antennæ annulate and somewhat longer than the fore wing; paired tufts of hair behind the eyes; legs long and slender, the outer spurs about half the length of inner; abdomen long, the claspers and anal tuft very largely developed. Fore wing with veins 3, 4, 5 well separated at origin, 7 curved and approximated to 8, 9 for a short distance; 10 also approximated to 8, 9. Hind wing with the cell about half the length of wing; veins 3, 4, 5 from angle; 6, 7 from upper angle, 7 anastomosing with 8.

Fig. 32.

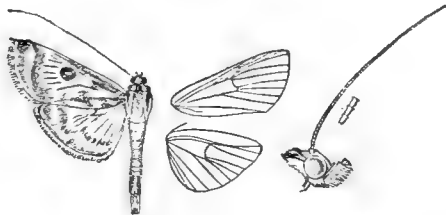

Rhimphalea trogusalis, ♂. †. (From Moths Ind. vol. iv.)

- (1) RHIMPHALEA TROGUSALIS Wlk. xviii. 711. Himalayas;
Botys megalopsalis Wlk. xxxiv. 1428. Assam; Philippines;
Pinacia ocularis Feld. Reis. Nov. pl. 136. f. 20. Borneo;
Spilomela ommatalis, Snell. Tijd. v. Ent. 1880, Celebes.
p. 235, & 1884, pl. 4. f. 5.
- (2)†RHIMPHALEA OCHALIS Wlk. xviii. 711. Assam; Java.
Spilomela strabonalis Snell. Tijd. v. Ent. 1880, p. 236.
- (3)†RHIMPHALEA ASTRIGALIS, n. sp. (Plate XLIX. fig. 25.)

Whitish; palpi, sides of frons, and tegulæ fuscous; thorax largely mixed with fuscous; legs striped with black; abdomen with lateral black stripes, the long terminal segment of male fuscous above with V-shaped white mark at extremity. Fore wing with subcostal fuscous fascia; subbasal and antemedial fuscous patches on inner area, the latter running out to a point on vein 1 and connected with subcostal fascia by traces of an

antemedial line; the end of median nervure, base of vein 2, and discocellulars marked with black and conjoined to a black spot in end of cell; a postmedial fuscous line with dentate marks on its inner side at veins 7 and 6, then excurved to vein 2, where it is connected by a bar with tornus, then retracted to near lower angle of cell; subterminal and terminal fuscous bands ending in a point on termen at vein 2; cilia fuscous. Hind wing with oblique discoidal fuscous bar; the postmedial line excurved below costa, bent outwards between veins 5 and 2, then retracted to near angle of cell and angled on vein 1; fine lines just inside termen, on termen, and through cilia.

Hab. Sandakan, Borneo (*Pryer*). *Exp.* 22 mm.

Differs from *ochalis* principally in being without the postmedial streaks on veins.

- Type.* (4) RHIMPHALEA SCELATALIS Led. Wien. Ent. Mon. N. Guinea; 1863, p. 411, pl. 15. f. 3. Australia.
 „ *papualis* Feld. Reis. Nov. pl. 136. f. 22.
 † „ *enone* Butl. Trans. Ent. Soc. 1886, p. 428.
- (5) RHIMPHALEA HERANIALIS Wlk. xviii. 714. Malay Pen.;
Polythlipta splendidalis Wlk. xxxiv. 1490. Borneo;
 New Guinea.
- (6) RHIMPHALEA LINDUSALIS Wlk. xviii. 712. Borneo;
 Solomons; Australia.
- (7) RHIMPHALEA CIRCOTOMA Meyr. Trans. Ent. Soc. 1889, p. 513.
 New Guinea.

Auctorum.

Rhimphalea fastidialis Snell. Tijd. v. Ent. xxiii. p. 228, & xxvii.
 pl. iii. ff. 7, 7 a. Celebes.

Genus 33. HYALEA.

Hyalea Guen. Delt. & Pyr. p. 206 (1854).

Palpi upturned, the 2nd joint broadly scaled in front, the 3rd short with a small triangular tuft; maxillary palpi dilated with scales; frons with a rounded prominence; antennæ annulate;

Fig. 33.

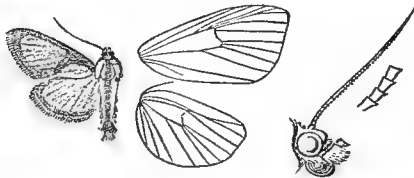

Hyalea dividatis, ♂. †.

tibiæ with the outer spurs about half the length of inner. Fore wing with veins 3, 4, 5 well separated at origin; 7 curved and approximated to 8, 9, to which 10 also is approximated. Hind

wing with veins 3, 4, 5 from angle of cell; 6, 7 from upper angle, 7 anastomosing with 8 to two-thirds of wing.

Type. (1) *HYALEA DIVIDALIS* Hübn. Zutr. p. 39. 390, ff. 779, 780.

Brazil.

(2) *HYALEA PALLIDALIS*, n. sp. (Plate XLIX. fig. 23.)

Differs from *dividalis* in being paler yellow. Fore wing with the oblique black fascia arising from base of costa; a small speck at middle of cell conjoined to the costal fascia and a triangular patch reaching to lower angle of cell; cilia of both wings white.

Hab. São Paulo (*Jones*); Peru. *Exp.* 22 mm.

(3)**HYALEA SUCCINALIS* Guen. Delt. & Pyr. p. 206.

Brazil.

Auctororum.

Hyalea glaucopidalis Guen. Delt. & Pyr. p. 207, pl. 8. f. 7.

Hab. ignotus.

Botys impeditalis Maasen, Stübel's Reise, p. 169, pl. ix. f. 22.

Ecuador.

Genus 34. *LEUCOCHROMA*.

Leucochroma Guen. Delt. & Pyr. p. 286 (1854).

Palpi upturned, the 2nd joint moderately scaled in front, the 3rd with a short triangular tuft; maxillary palpi filiform; frons rounded; antennæ of male annulated; tibiæ with the outer spurs less than half the length of inner. Fore wing with veins 3, 4, 5 from angle of cell; 7 curved and approximated to 8, 9, to which 10 also is approximated. Hind wing with veins 3, 4, 5 from angle of cell; 6, 7 from upper angle; 7 anastomosing with 8.

Fig. 34.

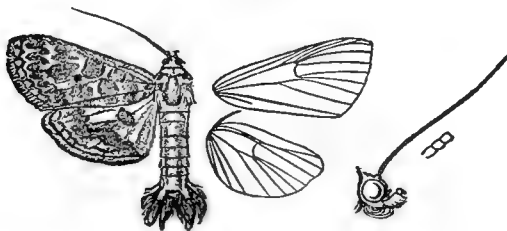

Leucochroma corope, ♂. $\frac{2}{3}$.

Type. (1) *LEUCOCHROMA COROPE* Cram. Pap. Exot. iv. p. 130, pl. 357. f. I. W. Indies; S. America.

Epipagis corrivalis Hübn. Verz. p. 358.

Phalæna splendidalis Cram. Pap. Exot. iv. p. 161, pl. 371. f. L.

Botys selectalis Wlk. xxxiv. 1396.

†*Leucochroma mineralis* Warr. Trans. Ent. Soc. 1889, p. 267.

(2)†*LEUCOCHROMA MELUSINALIS* Wlk. xvii. 492.

Venezuela.

Auctorum.

- Leucochroma prosalis* Druce, Biol. Centr.-Am., Het. ii. p. 266,
pl. 62. f. 30. Panama.
,, *saltigalis* Druce, Biol. Centr.-Am., Het. ii. p. 266,
pl. 62. f. 31. Panama.
,, *ruscialis* Druce, Biol. Centr.-Am., Het. ii. p. 266,
pl. 63. f. 1. Panama.

Genus 35. SYNGAMIA.

Syngamia Guen. Delt. & Pyr. p. 187 (1854).

Salbia Guen. Delt. & Pyr. p. 198.

Platamonia Led. Wien. Ent. Mon. 1863, p. 427.

Æthaloessa Led. Wien. Ent. Mon. 1863, p. 435.

Bacotoma Moore, Lep. Ceyl. iii. p. 382 (1885).

Orphanostigma Warr. A. M. N. H. (6) vi. p. 478 (1890).

Palpi upturned, the 2nd joint reaching vertex of head and broadly fringed with scales in front, the 3rd short, blunt, and with a small triangular tuft in front; frons oblique; antennæ with the shaft annulate; tibiæ with the outer spurs about half the length of inner; abdomen with long anal tuft in male. Fore wing with veins 3, 4, 5 from angle of cell; 7 straight and well separated from 8, 9, to which 10 is closely approximated. Hind wing with veins 3, 4, 5 from angle of cell; 6, 7 from upper angle, 7 anastomosing with 8 to two-thirds of wing.

Fig. 35.

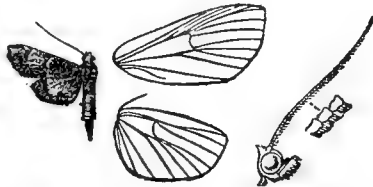

Syngamia floridalis, ♂. $\frac{1}{2}$. (From Moths Ind. vol. iv.)

SECT. I. (*Salbia*). Antennæ of male with the basal joint dilated and with a curved scale-tooth from extremity; the basal part of shaft much curved, with a small tuft of hair at base, followed by a very long tuft of curved black hair forming a hollow to contain the scale-teeth on curved portion of shaft.

A. Fore wing of male with a fringe of large scales on basal two-thirds of inner margin directed towards the costa.

(1) SYNGAMIA FLABELLALIS Guen. Delt. & Pyr. p. 199.

Botys tytiusalis Wlk. xix. 984.

W. Indies; Colombia.

Salbia abnormalis Snell. Tijd. v. Ent. 1875, p. 215, pl. 12.
ff. 7, 8.

- (2)*SYNGAMIA DEFORMALIS Snell. Tijd. v. Ent. 1875, p. 214,
pl. 12. ff. 4, 5, 6. Colombia.
- (3)*SYNGAMIA COGNATALIS Snell. Tijd. v. Ent. 1875, p. 215, pl. 12.
ff. 9, 10. Colombia.

B. Fore wing of male with a large fold on basal two-thirds of inner margin.

- (4) SYNGAMIA ANCIDALIS Snell. Tijd. v. Ent. 1875, p. 216, pl. 12.
ff. 11, 12. Brazil.

C. Fore wing of male with the base of costa produced to an angled lobe.

- (5) SYNGAMIA CASSIDALIS Guen. Delt. & Pyr. p. 199. W. Indies ;
Salbia squamosalis Wallengr. Eug. Resa, p. 382. Brazil.
- † „ *pellucidalis* Warr. Trans. Ent. Soc. 1889, p. 268.

SECT. II. (*Syngamia*). Antennæ of male normal.

- (6) SYNGAMIA RUBROCINCTALIS Guen. Delt. & Pyr. p. 204.
Salbia ditutalis, Wlk. xxxiv. 1301. Honduras.
Botys coidalis Feld. Reis. Nov. pl. 135. f. 14.
- (7) SYNGAMIA PEPITALIS Guen. Delt. & Pyr. p. 187. Bogota ;
Botys collaris Feld. Reis. Nov. pl. 135. f. 19. Brazil.
- (8) SYNGAMIA FLORELLA Cram. Pap. Exot. iv. p. 114, pl. 348. f. L.
Neotropical region.
Anania quisqualis Hübn. Zutr. iii. 27. 176, ff. 351, 352.

Type. (9)†SYNGAMIA FLORIDALIS Zell. Lep. Caffr. p. 60. S. Africa ;
Oriental region ; Pacific groups.

- Glyphodes calidalis* Guen. Delt. & Pyr. p. 294.
- †*Syngamia octavialis* Wlk. xvii. 334.
„ *merionealis*, Wlk. xvii. 334.
„ *tiphalis* Wlk. xvii. 335.
„ *secutalis* Wlk. xxxiv. 1291.
- Hyalea fulvidalis* Wallengr. Wien. Ent. Mon. 1860, p. 174.
Botys witalis Feld. Reis. Nov. pl. 135. f. 8.

- (10)*SYNGAMIA XANTHALIS, n. sp.

♀. Head fuscous and ochreous ; palpi fuscous, white below ; thorax fuscous above ; abdomen and wings ochreous yellow. Fore wing with basal purplish-fuscous patch narrowing to inner margin ; the costa fuscous to beyond middle ; a point at middle of cell ; a discocellular patch with yellow line on it ; the postmedial line erect from costa to vein 2, minutely dentate between veins 5 and 2, then retracted to join the discocellular patch and sinuous to inner margin, a large fuscous patch occupying the terminal area

from costa to vein 3, and a patch on inner area in the sinus of line leaving a yellow point beyond the line on inner margin. Hind wing with discocellular fuscous point; the postmedial line oblique and minutely waved from costa to vein 2, then somewhat retracted and reduced to points; the apical area fuscous from costa to vein 3.

Hab. Humboldt Bay, N. Guinea. *Exp.* 20 mm. Type in Coll. Rothschild.

(11)†SYNGAMIA FERVIDALIS Zell. Lep. Caffr. p. 59. S. Africa.
†*Asopia biblisalis* Wlk. xvii. 368.

(12)†SYNGAMIA ABRUPTALIS Wlk. xvii. 371; Moore, Lep. Ceyl. iii.
pl. 178. f. 14. W. Africa; Oriental region to
†*Asopia dotatalis* Wlk. xxxiv. 1305. Australia and Fiji.
,, *suffectalis* Wlk. xxxiv. 1307.

(13)†SYNGAMIA VIBIUSALIS Wlk. xviii. 634. W. Africa; S. India;
Burma.

(14) SYNGAMIA HÆMORRHOIDALIS Guen. Delt. & Pyr. p. 201.
†*Asopia dircealis* Wlk. xvii. 365. W. Indies; S. America.

(15) SYNGAMIA LATIMARGINALIS Wlk. xvii. 370; Moore, Lep. Ceyl.
iii. pl. 178. f. 16. W. & E. Africa;
†*Botys jucundalis* Led. Wien. Ent. Mon. 1863, India; Ceylon;
p. 463, pl. 8. f. 17. Burma.
Orphanostigma versicolor Warr. A. M. N. H. (6) xviii. p. 175.

(16)†SYNGAMIA FALSIDICALIS Wlk. xvii. 370. [India; Ceylon.

(17)*SYNGAMIA DENTILINEALIS, n. sp. (Plate XLIX. fig. 24.)

♀. Reddish brown; palpi white below; abdomen with yellowish segmental lines. Fore wing with the basal area mostly yellow, bounded by the antemedial line, which is obtusely angled on median nervure; a yellow spot in end of cell before the black discoidal lunule; the postmedial line bent outwards and dentate between veins 3 and 5, then retracted to angle of cell and obtusely angled on vein 1, a yellow patch on its inner side beyond the cell interrupted by brown streaks on the veins, a yellow patch beyond it in the sinus narrowing to inner margin and three spots on its inner side below the cell, a yellow streak from its angle on vein 3 to outer margin. Hind wing pale yellow; a dark discocellular spot connected with inner margin by an oblique sinuous line; the postmedial line strongly dentate and ending on outer margin above anal angle, the area beyond it fuscous; both wings with prominent series of yellow points on the cilia.

Hab. Bandong, Java. *Exp.* 24 mm. Type in Coll. Rothschild.

(18)†SYNGAMIA VIOLATA Fabr. Mant. Ins. ii. p. 213. Ceylon.
,, *abjungalis* Wlk. xviii. 670; Moore, Lep. Ceyl. iii.
pl. 180. f. 8.

- (19)*SYNGAMIA LATIFUSALIS Hmpsn. Moths Ind. iv. p. 281. Burma.
- (20)†SYNGAMIA CAMILLUSALIS Wlk. xviii. 713. Malacca; Borneo.
- (21) SYNGAMIA AMPLIATLIS Led. Wien. Ent. Mon. 1863, p. 428,
pl. 16, f. 6. Amboina; Solomons.
Botys illatalis Wlk. xxxiv. 1436.
- (22)†SYNGAMIA TYTIUSALIS Wlk. xviii. 605. W. Indies;
C. & S. America.
- (23)†SYNGAMIA VIOLESCENTALIS Hmpsn. A. M. N. H. (6) xvi.
p. 337 (♀). Grenada.
- (24) SYNGAMIA MARMORATA Lucas, Proc. Roy. Soc. Queensl. viii.
p. 92. Queensland.
Merodictya subtessellalis Warr. A. M. N. H. (6) xvii. p. 137.
- (25)*SYNGAMIA AQUATICALIS Guen. Delt. & Pyr. p. 284, pl. 8.
f. 4. Brazil.
Zebronia lacrinesalis Wlk. xix. 965.

Auctorum.

- Botys moluccalis* Feld. Reis. Nov. pl. 135. f. 13. Moluccas.
- Salbia præformatalis* Möschl. Abh. Senck. Ges. xvi. p. 291.
Porto Rico.

Genus 36. HILEITHIA.

Hileithia Snell. Tijd. v. Ent. 1875, p. 217.

Palpi upturned, the 2nd joint broadly scaled in front, the 3rd with a triangular tuft; maxillary palpi small and filiform; frons rounded; antennæ ciliated, in male with a tooth from extremity of basal joint; tibiæ with the outer spurs half the length of inner. Fore wing with veins 3, 4, 5 from angle of cell; 7 straight and well separated from 8, 9; 10, 11 stalked; male with a fold at base of costa below. Hind wing with veins 3, 4, 5 from angle of cell; 6, 7 from upper angle, 7 anastomosing with 8 to three-fourths of wing.

Fig. 36.

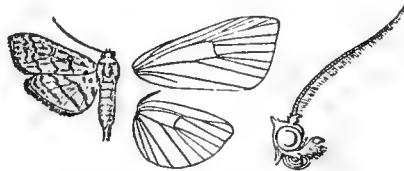

Hileithia decostalis, ♂. †.

- Type.* HILEITHIA DECASTALIS Guen. Delt. & Pyr. p. 229. S. America.
Samea melicertalis Wlk. xvii. 356.
Zebronia perseusalis Wlk. xvii. 475.
Hileithia appialis Snell. Tijd. v. Ent. xviii. p. 219, pl. 12,
ff. 13, 14.

*Auctorum.**Hileithia ductalis* Möschl. Abh. Senck. Ges. xvi. p. 292.

Porto Rico.

Genus 37. SAMEA.

Samea Guen. Delt. & Pyr. p. 193 (1854).

Palpi upturned, the 1st and 2nd joints broadly scaled in front, the 3rd with a small triangular tuft; maxillary palpi filiform; frons flat and oblique; antennæ of male ciliated; tibiæ with the outer spurs short. Fore wing with veins 4, 5 approximated for some distance; 7 curved and approximated to 8, 9, to which 10 also is approximated. Hind wing with veins 4, 5 approximated for some distance; 6, 7 from upper angle, 7 anastomosing with 8.

Fig. 37.

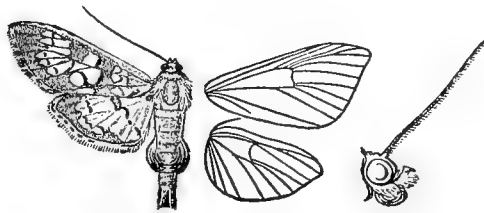
*Samea ecclesialis*, ♂. $\frac{3}{8}$.

SECT. I. Abdomen of male with large paired lateral medial tufts curled over dorsum.

Type. (1) SAMEA ECCLESIALIS Guen. Delt. & Pyr. p. 194, pl. 6. f. 7.

U.S.A.; W. Indies;
 „ *castellalis* Guen. Delt. & Pyr. p. 195. S. America.

„ *lucusalis* Wlk. xix. 937.

† „ *disertalis* Wlk. xxxiv. 1302.

(2) SAMEA MULTIPLICALIS Guen. Delt. & Pyr. p. 227. U.S.A.;

† „ *discessalis* Wlk. xxxiv. 1302. S. America.

† „ *nicæusalis* Wlk. xvii. 464.

SECT. II. Abdomen of male without tufts.

(3)*SAMEA ISARALIS Feld. Reis. Nov. pl. 135. f. 25. Bogota.

Auctorum.

Samea figuralis Wlk. Tr. N. H. Glasg. i. p. 368. Congo.

„ *fumidalis* Leech, Ent. xxii. p. 70, pl. iv. f. 8. Japan.

„ *conjunctalis* Möschl. Abh. Senck. Ges. xvi. p. 290.

Porto Rico.

Genus 38. TRITHYRIS.

Trithyris Led. Wien. Ent. Mon. 1863, p. 140.

Prænesta Snell. Tijd. v. Ent. 1875, p. 219.

Palpi upturned, the 2nd joint broadly scaled in front, the 3rd with a small triangular tuft; maxillary palpi filiform; frons with an oblique prominence; antennæ ciliated; tibiæ with the outer spurs half the length of inner. Fore wing with veins 3, 4, 5 well separated at origin; 7 straight and well separated from 8, 9, to which 10 is approximated. Hind wing with veins 3, 4, 5 from angle of cell; 6, 7 from upper angle, 7 anastomosing with 8.

Fig. 38.

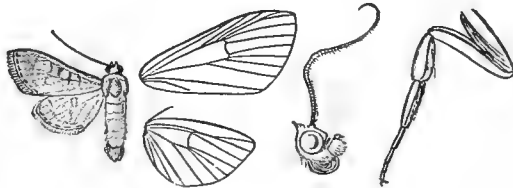

Trithyris scyllalis, ♂. †.

SECT. I. (*Prænesta*). Antennæ of male slightly thickened by scales at middle and contorted; anal tuft very large.

A. Fore leg of male with grooves containing tufts of hair in femur, tibia, and 1st joint of tarsus.

- (1)†TRITHYRIS SCYLLALIS Wlk. xviii. 566. Mexico; Brazil.
Botys turnusalis Wlk. xviii. 628.
 „ *delicatalis* Led. Wien. Ent. Mon. 1863, p. 376, pl. 11.
 f. 10.
Prænesta fabialis Snell. Tijd. v. Ent. 1875, p. 220, pl. 12.
 ff. 15, 16.

B. Fore leg of male with the groove running to end of tarsus.

- (2) TRITHYRIS SUNIALIS Snell. Tijd. v. Ent. 1875, p. 220, pl. 12.
 ff. 17, 18. Colombia.
- (3)†TRITHYRIS RUBRALIS, n. sp.

♂. Dark red; palpi, pectus, and ventral surface of abdomen black, the last with the terminal segments yellowish white; anal tuft black at base. Fore wing with traces of antemedial line with yellowish mark before it in cell; a prominent black-edged orange quadrate spot in end of cell, a discoidal black lunule; the post-medial line excurved to vein 2, then retracted to origin of vein 2, with an orange spot on its outer side and almost obsolete towards inner margin. Hind wing with discoidal annulate spot and curved

postmedial fuscous line; both wings with terminal series of black points and black line through the cilia, which are brown.

Hab. Peru. *Exp.* 34 mm.

Subsp. 1. Hind wing with orange spot in cell; both wings with large curved patch beyond the cell.—Ecuador, Loja.

SECT. II. (*Trithyris*). Antennæ of male normal.

A. Mid tibiæ of male greatly dilated with a groove containing a fringe of large scales.

(4)†*TRITHYRIS AURANTIACALIS* Warr. Trans. Ent. Soc. 1889, p. 289. Brazil.

(5)**TRITHYRIS PERTICALIS* Feld. Reis. Nov. pl. 135. f. 9. Bogota.
Botys galbula Feld. Reis. Nov. pl. 135. f. 20.

B. Mid tibiæ of male normal.

(6)†*TRITHYRIS IPHICLALIS* Wlk. xvii. 376. Brazil.

(7)†*TRITHYRIS PROTENORALIS* Wlk. xviii. 628. Brazil.

(8)†*TRITHYRIS NYSALIS* Wlk. xviii. 606. Brazil.

(9) *TRITHYRIS FENESTRINALIS* Guen. Delt. & Pyr. p. 341, pl. 15. f. 8. Brazil.

(10)†*TRITHYRIS PROSOPEALIS* Wlk. xvii. 358. W. Indies.

Type. (11)**TRITHYRIS JANUALIS* Led. Wien. Ent. Mon. 1863, p. 410, pl. 15. f. 2. Brazil.

(12) *TRITHYRIS LATIFASCIALIS* Snell. Tijd. v. Ent. xviii. p. 238, pl. xiii. f. 12. Colombia; Ecuador.

Auctorum.

Trithyris ignefactalis Möschl. Abh. Senck. Ges. xiv. p. 81. Jamaica.

Genus 39. *BOCCHORIS*.

Diastictis Hübn. Verz. p. 355 (1827), preocc.

Bocchoris Moore, Lep. Ceyl. iii. p. 271 (1886).

Chabula Moore, Lep. Ceyl. iii. p. 317.

Didymostoma Warr. A. M. N. H. (6) ix. p. 392 (1892).

Anomostictis Warr. A. M. N. H. (6) ix. p. 434.

Palpi upturned and reaching vertex of head, the 2nd joint moderately scaled in front, the 3rd with a short triangular tuft; maxillary palpi filiform; frons flat and oblique; antennæ with the shaft smooth; tibiæ with the outer spurs half the length of inner. Fore wing with veins 3, 4, 5 from angle of cell; 7 straight and well separated from 8, 9, to which 10 is approximated. Hind

wing with veins 3, 4, 5 from angle of cell; 6, 7 from upper angle, 7 anastomosing with 8.

Fig. 39.

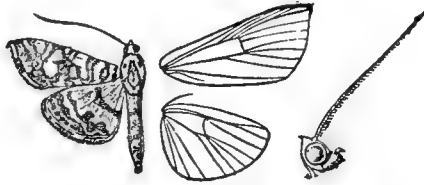

Bocchoris onychinalis, ♂. $\frac{3}{2}$. (From Moths Ind. vol. iv.)

SECT. I. Antennæ of male minutely serrate.

- (1)†*BOCCHORIS ROTUNDALIS* Hmpsn. Ill. Het. ix. p. 169, pl. 172.
f. 23. India; Ceylon.

SECT. II. Antennæ of male ciliated.

A. Fore wing of male with three hyaline streaks in the interspaces beyond the cell.

- (2)†*BOCCHORIS ADALIS* Wlk. xix. 989. Brazil.

B. Fore wing of male normal.

a. Both wings with the apex somewhat produced, the outer margin excised to vein 3, where it is angled.

- (3) *BOCCHORIS INVERTALIS* Snell. Tijd. v. Ent. 1877, p. 78, pl. 6.
f. 4. Burma; Sumatra; Borneo; Queensland; N. Guinea.

b. Outer margin of both wings rounded.

- (4)**BOCCHORIS JUNCTIFASCIALIS*, n. sp. (Plate XLIX. fig. 29.)

♀. White; palpi and frons brown at sides; antennæ, thorax, and abdomen at base of dorsum tinged with brown; the anal tuft black. Fore wing with the costal and inner areas black-brown to the postmedial line, each emitting a striga defined by white on inner side and representing the antemedial line; a large brown-outlined discoidal lunule conjoined, to the costal area and with a point between it and the brown inner area; a prominent slightly curved dark postmedial band, conjoined, except towards costa and inner margin, to a similar oblique almost straight subterminal band; a terminal band narrowing to tornus. Hind wing with discoidal point; a prominent straight postmedial dark band; a terminal band narrowing to tornus; both wings with fine black line through the cilia.

Hab. Banda (*Doherty*). *Exp.* 24 mm. Type in Coll. Rothschild.

- (5)†*BOCCHORIS INDUCTALIS* Wlk. xxxiv. 1450. Pulo Laut Java.

- (6)†*BOCCHORIS DANALIS* Hmps. Ill. Het. ix. p. 169, pl. 172. f. 25.
Ceylon.
- (7) *BOCCHORIS TRIVITRALIS* Swinh. A. M. N. H. (6) xvi. p. 302.
Assam.
Synclera fenestralis Warr. A. M. N. H. (6) xvi. p. 105.
- (8) *BOCCHORIS INSCISALIS* Snell. Tijd. v. Ent. 1880, p. 213, & 1883,
pl. 18. f. 16. Brazil; W. Africa; India; Ceylon;
†*Hydrocampa tenera* Butl. P. Z. S. 1883, p. 167. Celebes.
- (9)†*BOCCHORIS CONTORTILINEALIS* Hmps. A. M. N. H. (6) xvi.
p. 336. Grenada.
- (10) *BOCCHORIS ONYCHINALIS* Guen. Delt. & Pyr. p. 205, pl. 6. f. 9.
W. Africa; Aden; India, Ceylon, & Burma;
†*Zebronia braurealis* Wlk. xix. 971. Borneo; Australia.
Lepyrodes astomalis Feld. Reis. Nov. pl. 135. f. 22.
- (11)†*BOCCHORIS FLAVIBRUNNEA*, n. sp. (Plate XLIX. fig. 30.)
♂. Yellow-brown; head, thorax, and abdomen mixed with
white; palpi black, white at base and extremity; wings with
black-edged white markings. Fore wing with subbasal mark on
inner area; a curved antemedial line not reaching costa; a medial
patch in and below cell with a small spot beyond its lower
extremity; a reniform postmedial patch between veins 7 and 8
with small spot beyond it below vein 7; cilia fuscous at apex and
middle. Hind wing with the basal half white, extending on inner
area to two-thirds of wing and enclosing a small spot on vein 1;
the outer area yellowish, enclosing a postmedial white patch
between veins 2 and 7.
Hab. Natal, Malvern (*Marshall*). *Exp.* 16 mm.
- (12) *BOCCHORIS DARSANALIS* Druce, Biol. Centr.-Am., Het. ii.
p. 238, pl. 62. f. 6. Mexico; Centr. Am.; Brazil.
- (13)**BOCCHORIS MARUCALIS* Druce, Biol. Centr.-Am., Het. ii. p. 237,
pl. 62. f. 3. Mexico.
- (14)†*BOCCHORIS ACAMASALIS* Wlk. xix. 970. India, Ceylon, &
Burma; Java; Celebes.
†*Zebronia perspicualis* Wlk. xxxiv. 1347.
†*Botys flexissimalis* Wlk. xxxiv. 1426.
Heterocnephes strangulalis Snell. Tijd. v. Ent. 1880, p. 224, &
1884, pl. 3. f. 1.
- (15) *BOCCHORIS TELPHUSALIS* Wlk. xix. 974. Japan; N.E. India;
Burma; Borneo; Amboina.
Chabula reniferalis Snell. Trans. Ent. Soc. 1890, p. 616.
Glyphodes uncinialis Pag. J.B. Nass. Ver. xxxvii. p. 273,
pl. vii. f. 6.
- (16)**BOCCHORIS TEBEALIS* Wlk. xvii. 503. Borneo.

(17)†*Bocchoris sphenocosma* Meyr. Trans. Ent. Soc. 1894,
p. 456. Assam; Borneo; Pulo Laut.

†*Chabula vedrualis* Swinh. A. M. N. H. (6) xiv. p. 197.

(18) *Bocchoris minima* Von Hedem. Stett. Ent. Zeit. lv. p. 295.
Jamaica; St. Thomas.

(19)†*Bocchoris chalcidiscalis*, n. sp.

♂. White; head, thorax, and abdomen tinged with fuscous. Fore wing golden brown, leaving the margins white; a white speck in cell and another on discocellulars; a slight foveal depression below base of cell. Hind wing white.

Hab. Espiritu Santo, Brazil (*Jones*). *Exp.* 20 mm.

(20)†*Bocchoris stigmatalis*, n. sp.

White with slight yellowish tinge; palpi banded with black; head and thorax with black spots; abdomen with black bands, the anal segment in male with two lines which meet at apex. Fore wing with four black spots at base; a subbasal fuscous figure-of-eight shaped mark; an antemedial line slightly angled on median nervure; a large annulus in cell and discocellular reniform spot, the latter with two lines from it to inner margin, the inner emitting some irregular markings to the antemedial line; a postmedial line angled inwards on vein 5 and ending at outer angle; a diffused line across apex and a marginal line. Hind wing with discocellular annulus and a line from it to near anal angle; an irregular postmedial line forming an annulus at middle; submarginal and marginal lines; a small apical patch.

Hab. São Paulo, Brazil (*Jones*). *Exp.* 24 mm. Type in B.M.

(21)†*Bocchoris insipidalis* Led. Wien. Ent. Mon. 1863, p. 370,
pl. 8. f. 15. S. America.

(22)†*Bocchoris clathralis* Swinh. A. M. N. H. (6) xiv. p. 200.
Assam; Burma.

(23)†*Bocchoris pulveralis*, n. sp.

♂. Fuscous; head, thorax, and abdomen mixed with white, the last with dorsal black marks on last two segments; wings irrorated with yellowish white. Fore wing with numerous semi-hyaline white spots on basal two-thirds, forming ill-defined subbasal, antemedial, medial, and postmedial series, the last excurved between veins 5 and 2; subbasal and postmedial black points on costa. Hind wing with similar subbasal, medial, and postmedial series of spots; cilia of both wings chequered white and black.

Hab. Java, Arjuno (*Doherty*). *Exp.* 20 mm.

(24) *Bocchoris adipalis* Led. Wien. Ent. Mon. 1863, p. 475,
pl. 11. f. 16. India, Ceylon, & Burma;

Botys notatalis Wlk. xxxiv. 1437. Malacca; Amboina.

†*Samea cuprinalis* Moore, P. Z. S. 1877, p. 615.

Mimorista marginalis Warr. A. M. N. H. (6) xviii. p. 114.

(25)†*Bocchoris euphranoralis* Wlk. xix. 1004. Celebes.

(26) *BOCCHORIS AUROTINCTALIS*, n. sp.

Very pale golden yellow; thorax and abdomen slightly mottled with grey-brown, the latter with dorsal series of white points; pectus, legs, and ventral surface of abdomen white. Fore wing with irregular greyish-white basal patch; a slightly-curved pale brown antemedial line; the elongate orbicular and reniform spots grey with pale brown outline, the latter with incurved line from its lower edge almost meeting on inner margin another line from reniform which is angled outwards; a waved postmedial line; the medial area below the cell and the inner area between the outer line from reniform and the postmedial line greyish white; a grey-brown subterminal band with waved edges from costa to vein 3, with a line from its lower end to the postmedial line at vein 2; a brown marginal line. Hind wing with greyish antemedial band not reaching inner margin and with strong waved brown edges; irregularly waved postmedial and subterminal lines; a fine marginal line.

Hab. Fergusson I., N. Guinea (*Meek*), Queensland (*Meek*).
Exp. 28 mm. Types in Coll. Rothschild and B.M.

(27) *BOCCHORIS APTALIS* Wlk. xxxiv. 1425. Japan; Assam;
Mysol; Sangir.

†*Samea usitata* Butl. Ill. Het. iii. p. 74, pl. 59. f. 3.

†*Pyrausta platycapna* Meyr. Trans. Ent. Soc. 1897, p. 90.

(28)†*BOCCHORIS ARTIFICIALIS* Led. Wien. Ent. Mon. 1863, p. 463,
pl. 8. f. 16. N.W. Himalayas; Calcutta.

†*Ædiodes inscitalis* Wlk. xxxiv. 1297.

† „ *abstrusalis* Moore, Lep. Atk. p. 207.

(29)†*BOCCHORIS ACTEALIS* Wlk. xix. 944. S. America.

†*Samea dignotalis* Wlk. xxxiv. 1301.

(30) *BOCCHORIS ARGYRALIS* Hübn. Verz. p. 355, Zutr. i. 21. 57,
ff. 113, 114. U.S.A.

Botis ventralis Grote & Rob. Tr. Am. Ent. Soc. i. p. 21,
pl. 2. f. 23 (var.).

(31) *BOCCHORIS FRACTURALIS* Zell. Verh. z.-b. Ver. Wien, 1872,
p. 509, pl. 3. f. 16. U.S.A.; S. America.(32)†*BOCCHORIS CÆCALIS* Warr. A. M. N. H. (6) ix. p. 434.

California.

(33) *BOCCHORIS XANTHIALIS*, n. sp.

Orange-yellow; fore femora banded with fuscous. Fore wing with fuscous basal line; the broad antemedial line oblique from costa to below median nervure, where it is obtusely angled; a point in cell and discoidal spot; the broad postmedial line slightly incurved to vein 5, then strongly excurved, and at vein 2 retracted to angle of cell, where it is connected by a blotch with the discoidal spot; one or two subterminal spots below apex and one above tornus, the former sometimes conjoined to the postmedial

line. Hind wing with more or less developed fuscous postmedial line between veins 5 and 2 and sometimes with subterminal spots below apex and vein 2 or diffused subterminal band.

The postmedial line of fore wing sometimes becomes a broad diffused nearly straight band.

Hab. Amboina (*Doherty*); Queensland (*Meek*). *Exp.* 28 mm. Types in Coll. Rothschild and B.M.

(34)†*Bocchoris talis* Grote, Can. Ent. x. p. 26. U.S.A.

Type. (35) *Bocchoris inspersalis* Zell. Lep. Caffr. p. 33.

W. & S. Africa; Japan; Oriental region.

Desmia afflictalis Guen. Delt. & Pyr. p. 191, pl. 5. f. 4.

†*Ædiodes bootanalis* Wlk. xxxiv. 1298.

(36)†*Bocchoris ciliata* Swinh. A. M. N. H. (6) xiv. p. 206.

Assam.

(37) *Bocchoris trimaculalis* Snell. Tijd. v. Ent. xxiii. p. 232,
& xxxvii. pl. iv. ff. 2, 2a. Burma; Celebes.

(38) *Bocchoris quaternalis* Led. Wien. Ent. Mon. 1863, p. 434,
pl. 17. f. 1. Amboina; N. Guinea.

(39)†*Bocchoris clytialis* Wlk. xvii. 342. Brazil.

Genus 40. SALBIOMORPHA.

Salbiomorpha Snell. Tijd. v. Ent. 1875, p. 216.

Palpi upturned, the 2nd joint reaching vertex of head and broadly scaled in front, the 3rd short, blunt, and hidden by a tuft of hair from end of 2nd joint; maxillary palpi filiform; frons rounded; antennæ with the shaft annulate, in male with the basal joint dilated and with a curved scale-tooth from extremity, the basal part of shaft much curved, with a long tuft of hair between two small tufts of scales at base, and at the end of the

Fig. 40.



Salbiomorpha torsalis, ♂. †.

curved part a tuft of hair above and serrations below; tibiæ with the outer spurs half the length of inner; abdomen long in male. Fore wing of male with a fringe of large scales directed towards costa on basal two-thirds of inner margin; veins 3, 4, 5 from angle of cell; 7 straight and well separated from 8, 9, to which 10 is approximated. Hind wing with the costa lobed and angled at

middle in male; veins 3, 4, 5 approximated for a short distance; 6, 7 shortly stalked, 7 shortly anastomosing with 8.

Type. SALBIOMORPHA TORSALIS Guen. Delt. & Pyr. p. 200. Colombia.

Genus 41. PILOCROCIS.

Pilocrocis Led. Wien. Ent. Mon. 1863, p. 430.

Ceratoclasia Led. Wien. Ent. Mon. 1863, p. 430.

Anisoctena Meyr. Trans. Ent. Soc. 1894, p. 455.

Palpi upturned, the 2nd joint broadly rounded with scales in front, the 3rd short and with a small triangular tuft in front; maxillary palpi filiform; frons rounded; tibiæ with the outer spurs half the length of inner. Fore wing with veins 3, 4, 5 from angle of cell; 7 curved and approximated to 8, 9. Hind wing with vein 3 from angle of cell; 4, 5 somewhat approximated for a short distance; 6, 7 from upper angle, 7 anastomosing with 8.

Fig. 41.

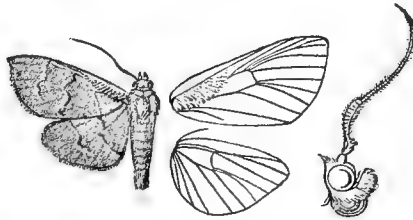

Pilocrocis ramentalis, ♂. †.

SECT. I. (*Ceratoclasia*). Antennæ of male distorted at two-thirds from base with a vesicle formed of appressed serrations and long spines projecting over it.

(1)†PILOCROCIS LAURALIS Wlk. xvii. 358.

W. Indies; S. America.

Ceratoclasia verecundalis Berg, Bol. Ac. Nac. Cord. i. p. 177. 15.

(2) PILOCROCIS DELIMITALIS Guen. Delt. & Pyr. p. 35.

W. Indies; S. America.

(3)*PILOCROCIS IMBREXALIS Wlk. xix. 987.

Brazil.

SECT. II. Antennæ of male with a process from basal joint in front, the base of shaft excised; patagia extending beyond metathorax.

(4) PILOCROCIS TRIPUNCTATA Fabr. Mant. Ins. ii. p. 213.

W. Indies; Colombia.

Botys campalis Guen. Delt. & Pyr. p. 345.

„ *cubanalisis* Guen. Delt. & Pyr. p. 345.

† „ *memmialis*, Wlk. xviii. 731.

(5) PILOCROCIS PLUMBICOSTALIS Grote, Can. Ent. iii. p. 103.

Florida.

SECT. III. Antennæ of male with scale-tooth on basal joint; the base of shaft excised followed by slight scale-teeth; under-side of both wings with rough scales in cell, hind wing with large recurved tufts of scales on medial part of costal area.

(6) *PILOCROCIS COPTOBASIS*, n. sp.

♂. Purplish fuscous; base of palpi and thorax and abdomen below white. Fore wing with small quadrate hyaline spot in end of cell and another below origin of vein 2; the postmedial line formed by three dentate hyaline marks beyond the cell, then three points nearer the termen, between veins 5 and 2, and a point near the hyaline spot below vein 2. Hind wing with the postmedial line represented by a spot beyond the cell, three points near the termen between veins 5 and 2, and a line from lower angle of cell to tornus.

Hab. Amboina; Celebes; Batchian (*Doherty*); Fergusson I., N. Guinea (*Meek*). *Exp.* 36 mm. Types in Coll. Rothschild and B. M.

SECT. IV. (*Anisoctena*). Antennæ of male with scale-tooth on basal joint; a deep excision at base of shaft followed by curved teeth on outer side for some distance; maxillary palpi dilated with scales. Fore wing with thick curled hair on base of inner margin met by a fringe of curved hair in upper part of cell; the median nervure and inner area clothed with long hair. Female normal.

(7)†*PILOCROCIS SYNOMOTIS* Meyr. Trans. Ent. Soc. 1894, p. 456.
Celebes.

SECT. V. Antennæ of male with the shaft fringed with hair on upperside at about one-sixth from base; frons with rounded prominence.

(8)†*PILOCROCIS PURPURASCENS*, n. sp.

Head, thorax, and abdomen dark fuscous brown; palpi at base, pectus, legs, and ventral surface of abdomen white; wings dark fuscous with a purplish gloss; both wings with faint traces of discoidal spot and postmedial line retracted at vein 3 to lower angle of cell.

Hab. Ecuador, Loja; Trinidad. *Exp.* 40 mm.

SECT. VI. (*Pilocrocis*). Antennæ of male with the base of shaft excised, then thickened and curved for some distance; fore wing with a thick fringe of hair and scales below basal half of costa.

Type. (9) *PILOCROCIS RAMENTALIS* Led. Wien. Ent. Mon. vii. p. 430,
pl. 16. f. 13. U.S.A.; Venezuela; Brazil.
Zinckenia perfuscalis Hulst, Tr. Am. Ent. Soc. xiii. p. 159.

SECT. VII. Antennæ of male normal.

- A. Hind tibiæ of male with large tufts of hair on outer side of tibia and proximal joints of tarsus; fore wing below with large fans of scales over the cell from below costal and subcostal nervures; the patagia extending beyond metathorax.

(10)† *PILOCROCIS DRYALIS* Wlk. xviii. 573. W. Indies.
Botys glaucusalis Wlk. xviii. 576.

- B. Hind tibiæ only with tufts of hair on outer side.

(11)† *PILOCROCIS XIPHALIS* Wlk. xviii. 594. Brazil.
Botys serratilinealis Led. Wien. Ent. Mon. 1863, p. 375, pl. ii. f. 2.

(12)† *PILOCROCIS CALAMISTIS*, n. sp.

♂. Ochreous yellow; palpi streaked with fuscous; fore tibiæ and femora ringed with fuscous; hind tibiæ with the tufts fuscous on outer side; abdomen slightly ringed with fuscous. Fore wing with slight fuscous streak below basal half of costa; a curved antemedial line angled inwards on vein 1; a speck in cell and discoidal lunule; the postmedial line incurved from costa to vein 5, then bent outwards and dentate to vein 5, along which it is retracted to near angle of cell. Hind wing with discoidal spot the postmedial line as on fore wing, but with an oblique fuscous shade in its sinus; both wings with fuscous terminal line.

Hab. Jalapa, Mexico (*Schaus*). *Exp.* 32 mm. Types in B.M. and Coll. *Schaus*.

C. Legs normal.

- a. Fore wing of male with an elongate fovea in cell.

(13) *PILOCROCIS INGUINALIS* Guen. Delt & Pyr. p. 346. U.S.A.; Brazil.

Botys thoasalis, Wlk. xviii. 610.

„ *anticostalis* Grote, Can. Ent. iii. p. 104.

- b. Fore wing of male with a small fovea below the base of cell enclosed by vein 1 being bent up to median nervure.

(14)† *PILOCROCIS XANTHYALINALIS*, n. sp.

♂. Pale silky yellow; palpi above, frons above and below, and base of tegulæ brown. Fore wing with brown fascia on costa; a brown point in cell and discoidal bar.

Hab. Aroa, Venezuela. *Exp.* 28 mm.

- c. Fore wing normal.

a'. (*Lotanga*). Patagia of male with a tuft of hair extending beyond metathorax.

(15) *PILOCROCIS BARCALIS* Wlk. xix. 1001.

India, Ceylon, & Burma; Borneo.
Deba milvinalis Swinh. P. Z. S. 1885, p. 875, pl. 57. f. 2;
Moore, Lep. Ceyl. iii. p. 183. f. 11.

(16) *PILOCROCIS ANIGRUSALIS* Wlk. xviii. 682 (♀). Borneo.

b'. Patagia normal.

- (17)**PILOCROCIS ROXONALIS* Druce, Biol. Centr.-Am., Het. ii. p. 253, pl. 62. f. 20. Centr. Am.
- (18) *PILOCROCIS LIBERALIS*, Guen. Delt. & Pyr. p. 350. Cayenne ; Brazil.
- (19)†*PILOCROCIS LEUCOPLAGALIS*, n. sp. (Plate XLIX. fig. 18.)
 Fuscous shot with purplish blue ; palpi ochreous below ; pectus and ventral surface of abdomen white ; anal tuft of male ochreous. Fore wing with semihyaline purplish fascia below the cell and vein 2 and above base of vein 2 ; a spot in end of cell ; an oblique white somewhat wedge-shaped band beyond the cell from vein 7 to above 2. Hind wing with the interspaces semihyaline except on terminal area.
Hab. Mexico, Jalapa (*Schaus*) ; Brazil, Castro Paraña (*Jones*). *Exp.* 42 mm. Types in B.M. and Coll. Schaus.
- (20) *PILOCROCIS DAMONALIS* Wlk. xviii. 617. Brazil.
- (21)†*PILOCROCIS GILIPPUSALIS* Wlk. xviii. 536. Brazil.
- (22) *PILOCROCIS INFUSCALIS* Guen. Delt. & Pyr. p. 350.
Botys agavealis Wlk. xviii. 574. W. Indies ; Brazil.
 „ *pruinialis* Led. Wien. Ent. Mon. 1863, p. 373, pl. 9. f. 6.
 „ *fuliginialis* Wlk. xxxiv. 1400.
- (23) *PILOCROCIS ANORMALIS* Guen. Delt. & Pyr. p. 352.
Botys alvinalis Guen. Delt. & Pyr. p. 352. Cayenne ; Brazil.
- (24)†*PILOCROCIS DISCODONTALIS*, n. sp.
 ♂. Greyish brown with a yellowish tinge. Fore wing with oblique sinuous antemedial line ; a minute annulus in cell ; a pale-centred discoidal lunule with a large yellowish hyaline patch beyond it on inner side of postmedial line, which is oblique from costa to vein 5, then bent outwards and dentate to vein 2, retracted to lower angle of cell and excurved again, a series of small dentate ochreous marks on its outer side from costa to vein 2. Hind wing ochreous suffused with brown, especially on inner area and beyond the cell ; a dark discoidal mark ; the postmedial line bent outwards and dentate between veins 5 and 2, then retracted to lower angle of cell and ending at tornus ; the apical area brown ; a brown line at base of cilia.
Hab. Venezuela, Aroa. *Exp.* 28 mm.
- (25)**PILOCROCIS CYRISALIS* Druce, Biol. Centr.-Am., Het. ii. p. 255, pl. 62. f. 23. Centr. Am.
- (26)**PILOCROCIS CRYPTALIS* Druce, Biol. Centr. Am., Het. ii. p. 255, pl. 62. f. 22. Centr. Am.

(27)†*PILOCROCIS MACERALIS* Wlk. xix. 940. Brazil.

(28) *PILOCROCIS CONFIXALIS* Wlk. xxxiv. 1430. Borneo ;
Botys conjunctalis Wlk. xxxiv. 1437. Sumbawa ; N. Guinea.

(29) *PILOCROCIS LATIFUSCALIS*, n. sp.

Pale ochreous brown ; palpi fuscous, white below. Fore wing with indistinct curved fuscous antemedial line ; a discoidal lunule ; both wings with the postmedial line excurved from costa to vein 2, retracted to below angle of cell, then slightly excurved again ; the terminal area broadly fuscous, leaving a band of the ground-colour between it and postmedial line.

Hab. Amboina (*Doherty*). *Exp.* 22 mm. Types in Coll. Rothschild and B.M.

(30)†*PILOCROCIS ACUTANGULA*, n. sp.

Yellowish white ; palpi fuscous, white at base ; shoulders streaked with fuscous brown. Fore wing with the costa and termen brown ; an oblique straight antemedial line joined at inner margin by the postmedial line, which is obliquely curved from costa to termen at vein 2, where it is very acutely angled, then retracted to angle of cell and incurved to inner margin ; a point in cell and discoidal lunule. Hind wing with discoidal lunule ; the postmedial line acutely angled at vein 3, then retracted to angle of cell ; lines on termen and through cilia.

Hab. Sandakan, Borneo (*Pryer*). *Exp.* 22 mm.

(31)†*PILOCROCIS TRISTIGMALIS*, n. sp.

♀. Brown tinged with fuscous ; head and tegulæ blackish ; abdomen with black band on 2nd segment and dorsal points on following segments. Fore wing with the costa suffused with black ; an obscure subbasal line ; an antemedial black line obtusely angled on median nervure ; prominent black stigmata in and below middle of cell ; a large discoidal stigma ; the postmedial line bent outwards and dentate between veins 5 and 2, then retracted to below end of cell ; the apical area black and angled inwards to the postmedial line above vein 5 ; some black at tornus. Hind wing with discoidal black line ; the postmedial line bent outwards and dentate between veins 5 and 2 ; apical area suffused with black ; the termen black ; cilia whitish intersected with black.

Hab. Florida, Miami (*Schaus*). *Exp.* 28 mm.

(32) *PILOCROCIS CHLORISALIS* Wlk. xviii. 601. Mexico ; Brazil.

(33)†*PILOCROCIS MELANOPROCTIS*, n. sp.

♂. Head brown ; base of palpi ochreous ; thorax and abdomen ochreous, the anal tuft black. Fore wing ochreous ; the costal area fuscous ; an obliquely sinuous antemedial dark line with a small annulus in the cell beyond it ; a large ochreous-centred

discocellular reniform dark patch with a waved postmedial line with large dark apical patch beyond it, bent outwards and dentate between veins 5 and 2, then retracted to the discocellular patch, and with a patch beyond it extending to outer angle and two small ochreous spots on its outer edge. Hind wing ochreous, with discocellular speck; the postmedial line much bent outwards and dentate between veins 5 and 2; an apical dark patch and series of marginal specks.

Hab. São Paulo, Brazil (*Jones*). *Exp.* 34 mm.

(34) *PILOCROCIS COLLUSTRALIS* Möschl. *Abh. Senck. Ges.* xiv. 3, p. 76. Jamaica.

Auctorum.

Ceratoclasia tenebralis Snell. *Tijd. v. Ent.* xviii. p. 246, pl. xiv. ff. 2, 3. W. Indies.

„ *rooalis* Snell. *Tijd. v. Ent.* xviii. p. 247, pl. xiv. f. 4. W. Indies.

„ *metalalis*, Möschl. *Abh. Senck. Ges.* xvi. p. 320. Porto Rico.

Genus 42. *ULOPEZA*.

Ulopeza Zell. *Lep. Caffr.* p. 58 (1852).

Xacca Wlk. *Proc. N. H. Glasg. Soc.* vol. i. 2, p. 370 (1869).

Pseudanalthes Warr. *A. M. N. H.* (6) vi. p. 477 (1890).

Palpi upturned, the 2nd joint reaching vertex of head and slightly fringed in front, the 3rd well developed and acuminate, with a short triangular tuft in front; maxillary palpi filiform; frons rounded; antennæ of male ciliated, the basal joint dilated and toothed, the shaft excised, then clothed with rough black scales for a short distance; tibiæ with the outer spurs half the

Fig. 42.

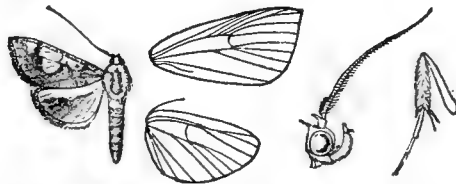

Ulopeza idyalis, ♂. 1. (From *Moths Ind.* vol. iv.)

length of inner; mid tibiæ clothed with spinous hair. Fore wing with the apex somewhat produced and the outer margin oblique; veins 3, 4, 5 from angle of cell; 7 curved and approximated to 8, 9 for a short distance; 10 also approximated to 8, 9. Hind wing with veins 3, 4, 5 from angle of cell, which is rather short; 6, 7 from upper angle or shortly stalked, 7 anastomosing slightly with 8.

SECT. I. (*Ulopeza*). Thorax of male below with ridges of large scales; fore coxæ and femora, hind tibiæ and spurs fringed with long hair.

- (1)†*ULOPEZA CONIGERALIS* Zell. Lep. Caffr. p. 58. W. & S. Africa.
†*Xacca trigonalis* Wlk. Proc. N. H. Soc. Glasg. vol. i. 2, p. 370.

SECT. II. (*Pseudanaltes*). Thorax of male and legs normal.

- Type.* (2)†*ULOPEZA IDYALIS* Wlk. xix. 996; Moore, Lep. Ceyl. iii. pl. 183.
f. 5. India; Ceylon; Borneo; Celebes.
Botys disjunctalis Wlk. xxxiv. 1408.

- (3) *ULOPEZA SEMIVIALIS* Moore, Lep. Atk. p. 209, pl. 7. f. 6.
Sikhim.

- (4)**ULOPEZA TENEBROSALIS* Warr. A. M. N. H. (6) xvi. p. 101 (♀).
Queensland.

Genus 43. NOSOPHORA.

Nosophora Led. Wien. Ent. Mon. 1863, p. 407.

Analtes Led. Wien. Ent. Mon. 1863, p. 407.

Eidama Wlk. xxxiv. 1374 (1865).

Palpi upturned, the 2nd and 3rd joints recurved over vertex of head, the 1st and 2nd joints in female slightly fringed with hair in front, the 3rd with a small triangular tuft in front, in male the 2nd joint is fringed with long coarse hair curled upwards and inwards; maxillary palpi filiform; frons rounded; antennæ of male with long cilia, the basal joint dilated with scales; the vertex of

Fig. 43.

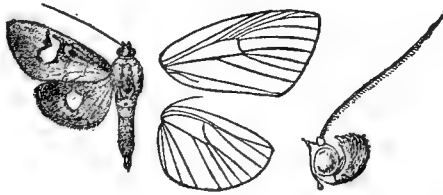

Nosophora althealis, ♂. †. (From Moths Ind. vol. iv.)

head hollowed out in male; the patagia with tufts of long hair extending beyond the metathorax; thorax below with ridges of large curved scales near the coxæ, a tuft of long hair from origin of fore wing; tibiæ with the outer spurs half the length of inner; mid tibiæ clothed with spinous hair. Fore wing with veins 3, 4, 5 from angle of cell; 7 curved and approximated to 8, 9 for one-third length; 10 also approximated to 8, 9. Hind wing with veins 3, 4, 5 usually from angle of cell; 6, 7 usually from upper angle, 7 slightly anastomosing with 8.

SECT. I. Fore wing of male with tufts of rough hair in middle and end of cell below.

- (1)†NOSOPHORA SCOTAULA Meyr. Trans. Ent. Soc. 1894, p. 459.
Burma; Singapore; Pulo Laut.
(2)†NOSOPHORA ALBIGUTTALIS Swinh. Trans. Ent. Soc. 1890,
p. 273, pl. viii. f. 14. Burma.

SECT. II. Fore wing without tufts of hair in cell below.

A. Hind wing of male with a ridge of hair on underside below subcostal nervure from near base to beyond the cell; veins 4, 5 from a point well above lower angle of cell; 6, 7 stalked.

a. Male with the whole hind tibia, the inner terminal spur, and the tarsal joints fringed with long hair.

- (3) NOSOPHORA CHIRONALIS Wlk. xviii. 683. Assam; Borneo.
Nagia incomitata Swinh. A. M. N. H. (6) xiv. p. 205.

b. Male with the hind tibia, the inner spur, and the 1st two tarsal joints fringed with hair.

- (4) NOSOPHORA CONJUNCTALIS Wlk. xxxiv. 1483. Assam; Burma;
Malayan subregion to Australia.
,, *ochnodes* Meyr. P. Linn. Soc. N. S. W. 1886, p. 255.

c. Male with slight tufts of hair at end of hind tibiæ only.

- (5) NOSOPHORA TRIGUTTALIS Warr. A. M. N. H. (6) xviii. p. 173.
Khásis; Burma.

- (6)*NOSOPHORA PARVIPCUNTALIS Hmps. Moths Ind. iv. p. 290.
Burma.

B. (*Nosophora*). Hind wing of male with a tuft of hair in cell and a short ridge beyond the cell; the hind tibia, the inner terminal spur, and the whole tarsus fringed with hair.

- Type. (7)†NOSOPHORA DISPILALIS Hmps. Moths Ind. iv. p. 288.
Assam; Borneo; Pulo Laut; Amboina.
,, *chironalis* Led. Wien. Ent. Mon. 1863, p. 407,
pl. 14. f. 12 (*nec* Wlk.).

C. (*Analtes*). Hind wing of male with no ridge of hair below subcostals; veins 4, 5 and 6, 7 from angles of cell.

a. Hind tibia of male fringed towards extremity with long hair, the inner terminal spur and 1st tarsal joint also fringed with hair.

- (8)†NOSOPHORA OBLIQUALIS Hmps. Ill. Het. ix. p. 170, pl. 173.
f. 5. Ceylon.

- (9)*NOSOPHORA EUSPILALIS Wlk. xxxiv. 1489 (♀). New Guinea.

b. Male with the hind tibia, the inner terminal spurs, and the tarsus naked.

α'. Male with thick fringe of hair on inner area of hind wing above.

(10)†*NOSOPHORA BARBATA*, n. sp. (Plate L. fig. 2.)

♂. Black-brown; palpi yellowish in front; pectus and legs whitish; fore tibiæ banded with fuscous; abdomen whitish below. Fore wing with oblique triangular yellow patch on middle of costa enclosing the dark discoidal bar, extending nearly to vein 2, and with its edges irregular, a fulvous yellow spot beyond it just below costa. Hind wing with the fringe of hair on inner area reddish.

Hab. Fergusson I., N. Guinea (*Meek*). *Exp.* 30 mm. Type in B.M.

b'. Male without fringe of hair on inner area of hind wing.

(11) *NOSOPHORA ALTHEALIS* Wlk. xviii. 697. India; Ceylon & Malayan subregion to New Guinea.

Analtes congenitalis Wlk. xxxiv. 1488.

†*Nosophora quadrisignata* Moore, Lep. Ceyl. iii. p. 320, pl. 183. f. 6.

(12) *NOSOPHORA SEMITRITALIS* Led. Wien. Ent. Mon. 1863, p. 407, pl. 14. f. 14. Sikhim; Pulo Laut; Amboina.

Botys palpalis Wlk. xxxiv. 1430.

(13)†*NOSOPHORA FULVALIS*, n. sp.

Yellow suffused with fulvous; palpi black at extremity; pectus and underside of abdomen whitish; lateral black streaks on terminal half of abdomen. Fore wing with the basal part of costa dark, terminating in a curved antemedial line; a postmedial dark line nearly straight from costa to vein 2, along which it is retracted to below end of cell, then slightly excurved again, the area between the two lines in and beyond end of cell clear yellow with a rufous discoidal line; the terminal area more suffused with fulvous; the costa towards apex and cilia fuscous. Hind wing with whitish spot beyond the cell edged with fuscous except above; the cilia fuscous.

Hab. Pulo Laut (*Doherty*); Fergusson I., N. Guinea (*Meek*). *Exp.* 30 mm. Type in B.M.

(14)**NOSOPHORA HYPHALIS* Wlk. xxxiv. 1374.

Aru.

(15) *NOSOPHORA FLAVIBASALIS*, n. sp. (Plate L. fig. 3.)

♂. Fuscous; palpi yellow except at extremity; tegulæ and patagia yellow in front; legs yellow and fuscous; abdomen with the basal segment yellow, followed by a dorsal streak ending just beyond middle; the ventral surface yellowish white. Fore wing with yellow subbasal patch in and below cell; a slight streak on basal part of vein 2; a hyaline point in end of cell and a large elliptical spot beyond the cell between veins 3 and 6. Hind wing

with large elliptical semihyaline spot between veins 2 and 5 from below middle of cell to near outer margin.

Hab. Humboldt Bay, N. Guinea (*Doherty*). *Exp.* 28 mm. Types in Coll. Rothschild and B.M.

(16)†*NOSOPHORA PANARESALIS* Wlk. xix. 992 (♀). W. Africa.

(17)†*NOSOPHORA LATIFERALIS* Wlk. xxxiv. 1401 (♀).
W. & S. Africa.

Auctorum.

Analtes tripunctalis Pag. J.B. Nass. Ver. xxxvii. p. 275, pl. vi. f. 5.
Amboina.

„ *unipunctalis* Pag. J.B. Nass. Ver. xxxvii. p. 276. Amboina.

Genus 44. CHALCIDOPTERA.

Chalcidoptera Butl. A. M. N. H. (1883) ii. p. 120.

Euthalantha Snell. Tijd. v. Ent. 1894, p. 42.

Palpi upturned, the 2nd joint reaching vertex of head and slightly scaled in front, the 3rd well developed, with a small triangular tuft in front; maxillary palpi small and filiform; frons rounded; antennæ of male ciliated. Fore wing with veins 3, 4, 5 well separated at origin; 7 straight and well separated from 8, 9, to which 10 is approximated. Hind wing with the cell about half the length of wing; 3 from angle; 4, 5 somewhat approximated for a short distance, 6, 7 from upper angle, 7 anastomosing slightly with 8.

Fig. 44.

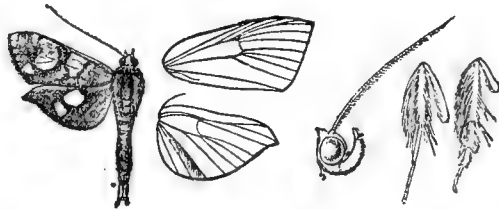

Chalcidoptera emissalis, ♂. †. (From Moths Ind. vol. iv.)

SECT. I. Antennæ of male with the shaft knotted at one-third from base, then excised, gradually thickened and clothed on upperside with rough scales; abdomen with a large bilobed corneous valve on underside from base covering the spiracles.

(1) CHALCIDOPTERA STRAMINALIS Guen. Delt. & Pyr. p. 200.

N. India.

†*Synclera nemoralis* Swinh. P. Z. S. 1889, p. 421, pl. 44. f. 6.

SECT. II. Antennæ of male with the base of shaft thickened and slightly excised, the outer margin of both wings excurved at middle; hind wing with a small lobe on inner margin near anal angle.

(2)*CHALCIDOPTERA ATRILOBALIS Hmps. Moths Ind. iv. p. 292.

Burma.

SECT. III. Antennæ of male with a small tooth on outer side of basal joint at extremity, the base of shaft curved and thickened with scales.

- (3) CHALCIDOPTERA RUFILINEALIS Swinh. A. M. N. H. (6) xvi. p. 303. Assam.

SECT. IV. Antennæ of male with two tufts of scales on basal joint and a curved hook at extremity; frons with long upcurved hair; vertex of head hollowed out; hind tibiæ with tuft of long hair at extremity, the inner spurs very long; hind wing with large patch of rough hair in cell below.

- (4)†CHALCIDOPTERA PRYERI, n. sp. (Plate L. fig. 1.)

♂. Deep red; frons and vertex of head ochreous; palpi at base, pectus, and underside of legs white; abdomen fuscous above except at base. Fore wing with the costa fuscous; a small yellow spot in end of cell; a large rather irregular lunulate spot beyond the cell between veins 2 and 7, with two specks beyond its upper extremity and one beyond its lower; cilia fuscous. Hind wing with the costal and inner areas, the termen and cilia fuscous, leaving a large triangular red patch below and beyond the cell, bearing a subquadrate hyaline spot between veins 2 and 5.

Hab. Sandakan, Borneo (*Pryer*). *Exp.* 20 mm.

SECT. V. Antennæ of male normal; patagia extending beyond metathorax.

- A. Mid and hind tibiæ fringed with immensely long hair on outer side, the inner spurs very long; hind tarsi with the first two joints fringed with long hair on both sides; hind wing with the costa slightly excised beyond middle, the apex much produced and falcate; rough hair on end of vein 1 *c* below.

Type. (5) CHALCIDOPTERA EMISSALIS Wlk. xxxiv. 1421. N.E. India; *Analthes crinipes* Feld. Reis. Nov. pl. 134. Ceylon; Burma; fig. 43. Singapore; Borneo; Amboina; *Chalcidoptera rubra* Butl. A. M. N. H. 1883, ii. p. 120. Aru. †*Analthes pyrrhocosma* Meyr. Trans. Ent. Soc. 1894, p. 460.

- B. Mid and hind tibiæ smoothly scaled; hind wing normal.

- (6) CHALCIDOPTERA APPENSALIS Snell. Tijd. v. Ent. 1884, p. 41, pl. 3. f. 12. N.E. India; Ceylon; Burma; Java.

- (7)*CHALCIDOPTERA ÆDILIS Meyr. Trans. Ent. Soc. 1887, p. 227.

Entephria excurvalis Warr. A. M. N. H. (6) xviii. p. 175.

Australia.

- (8)†CHALCIDOPTERA BILUNALIS, n. sp.

♂. Fuscous brown; palpi white at base. Fore wing with obliquely sinuous antemedial dark line; a white spot in cell; a

large postmedial white lunule with dentate outer edge extending from vein 8 to 2 and placed on the sinuous dark postmedial line which is retracted to below angle of cell. Hind wing with large white lunule beyond the cell with dentate outer edge, and with the oblique postmedial line rising from it; both wings with pale line at base of cilia.

Hab. Sierra Leone (*Clements*). *Exp.* 24–28 mm. Types in B.M. and Coll. Schaus.

Genus 45. MESOCONDYLA.

Mesocondyla Led. Wien. Ent. Mon. 1863, p. 392.

Eulepte Hübn. Zutr. vi. 3. i. B. 1 (1827), non descr.

Palpi upturned, the 3rd joint long with downturned scales in front, forming a hook at its base; maxillary palpi filiform; frons rounded; tibiae with the outer spurs half the length of inner. Fore wing with veins 3, 4, 5 from angle of cell; 7 curved and approximated to 8, 9, to which 10 also is approximated. Hind wing with vein 3 from angle of cell; 4, 5 approximated for a short distance; 6, 7 shortly stalked, 7 anastomosing with 8.

Fig. 45.

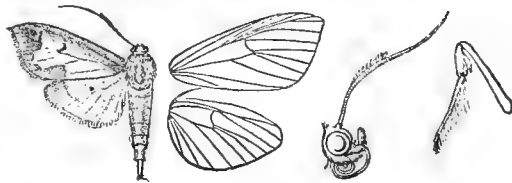

Mesocondyla dardusalis, ♂. †.

SECT. I. (*Mesocondyla*). Antennæ of male dilated and with tufts of scales at middle; patagia short; fore tarsi fringed with hair on inner side.

Type. (1) MESOCONDYLA DARDUSALIS Wlk. xviii. 513. S. America.
 „ „ *stigmatalis* Led. Wien. Ent. Mon. 1883, p. 392,
 pl. 13. f. 3.

SECT. II. (*Eulepte*). Antennæ of male with the basal joint immensely dilated and bearing tufts of hair on inner side; patagia extending to middle of abdomen.

(2) MESOCONDYLA CONCORDALIS Hübn. Zutr. vi. 3. i. B. 1. ff. 1–4.
 W. Indies; S. America.

Botys gastralis Guen. Delt. & Pyr. p. 346.

„ *peranthusalis* Wlk. xviii. 610.

† „ *ogmiusalis* Wlk. xviii. 730.

Phalena socialis Sepp, Surinam, iii. pl. 114.

Botys levalis Hulst, Tr. Am. Ent. Soc. xiii. p. 152.

SECT. III. Antennæ of male normal ; fore tarsi with the 1st two joints fringed on both sides with hair.

(3)†MESOCONDYLA TARSIBARBALIS, n. sp.

♂. Head, thorax, and abdomen fuscous ; white at base below ; patagia tipped with ochreous ; abdomen pale at base. Fore wing semihyaline ochreous with broad cupreous fuscous costal fascia from inner margin near base, including the obscure discocellular lunule ; a broad marginal cupreous fuscous band irregularly dentate from costal fascia to vein 2, along which it runs inwards to below angle of cell. Hind wing semihyaline ochreous with apical fuscous patch ; a black speck at lower angle of cell.

Hab. Santarem, Brazil (*Austen*). *Exp.* 38 mm.

Genus 46. LEUCOPHOTIS.

Leucophotis Butl. Trans. Ent. Soc. 1886, p. 426.

Palpi upturned, the 2nd joint reaching above vertex of head and broadly scaled in front, the 3rd fringed with scales in front and well developed ; maxillary palpi nearly filiform ; frons flat and oblique ; antennæ of male serrate ; tibiæ with the outer spurs half the length of inner. Fore wing with vein 3 from angle of cell ; 4, 5 approximated for a short distance ; 7 curved and approximated to 8, 9, to which 10 also is approximated. Hind wing with vein 3 from angle of cell ; 4, 5 approximated for some distance ; 6, 7 from upper angle, 7 hardly anastomosing with 8.

Fig. 46.

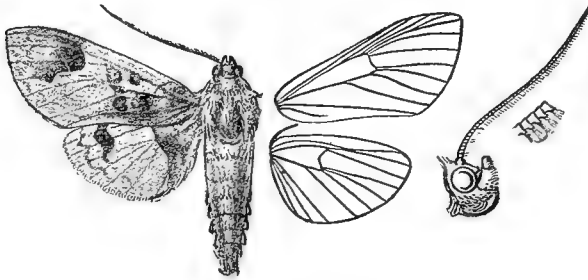

Leucophotis pulchra, ♂. †.

Type. †LEUCOPHOTIS PULCHRA Butl. Trans. Ent. Soc. 1886, p. 426. Fiji.

Genus 47. CAPRINIA.

Caprinia Wlk. xviii. 543 (1859).

Cydalima Led. Wien. Ent. Mon. 1863, p. 397.

Palpi upturned, very broadly rounded with scales and tapering to apex ; maxillary palpi dilated with scales ; frons rounded ; antennæ with the shaft nearly simple ; tibiæ with the outer spurs

less than half the length of inner; male with the anal tuft large. Fore wing with the costa highly arched towards apex; veins 3, 4, 5 from angle of cell; 7 curved and closely approximated to 8, 9 for nearly half its length; 10 also approximated to 8, 9. Hind wing with vein 3 from angle of cell; 4, 5 closely approximated for a short distance; the discocellulars slightly angled and nearly erect; 6, 7 from upper angle or shortly stalked, 7 anastomosing with 8.

Fig. 47.

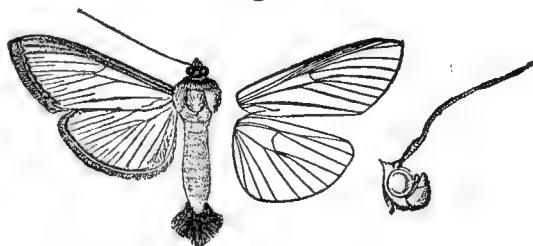

Caprinia conchylalis, ♂. †. (From Moths Ind. vol. iv.)

SECT. I. Antennæ of male with two teeth on base of shaft with a sinus between them; fore wing with a costal fold enclosing a tuft of hair.

(1)†CAPRINIA CIRRHALIS Swinh. A. M. N. H. (6) xix. p. 170.
S. Borneo.

SECT. II. Antennæ of male with the base of shaft excised; fore wing with a costal fold enclosing a tuft of long hair.

(2) CAPRINIA DIAPHANALIS Wlk. xxxiv. 1365. Burma; Java; Solomons; New Britain; Australia.

†*Botys margaronalis* Wlk. xxxiv. 1442.

†*Margaronia plumifera* Butl. A. M. N. H. 1882, i. p. 236.

SECT. III. (*Cydalima*). Antennæ of male with the basal joint dilated, the basal part of shaft thickened with scales and contorted.

(3) CAPRINIA CONCHYLALIS Guen. Delt. & Pyr. p. 303, pl. 8. f. 9.
India; Burma; Andamans.

SECT. IV. (*Caprinia*). Antennæ of male normal.

Type. (4)†CAPRINIA PERIUSALIS Wlk. xviii. 543. Venezuela.

(5) CAPRINIA FELDERI Led. Wien. Ent. Mon. 1863, p. 401.
Assam; Java; Amboina.

„ *intermedia* Warr. A. M. N. H. (6) xvii. p. 100.

(6)†CAPRINIA HYPHEUSALIS Wlk. xviii. 523. Brazil.

(7)†CAPRINIA CONGLOBATALIS Wlk. xxxiv. 1421. Flores.

Genus 48. SPILOMELA.

Spilomela Guen. Delt. & Pyr. p. 280 (1854).

Palpi upturned, conical, and reaching vertex of head; maxillary palpi filiform; frons rounded; antennæ annulate and as long as the fore wing; legs long and slender, the outer spurs half the length of inner; abdomen of male with long anal tuft. Fore wing with veins 3, 4, 5 from angle of cell; 7 curved and approximated for a short distance to 8, 9, to which 10 also is approximated. Hind wing with vein 3 from angle of cell; 4, 5 approximated for a short distance; 6, 7 shortly stalked, 7 anastomosing with 8.

Fig. 48.

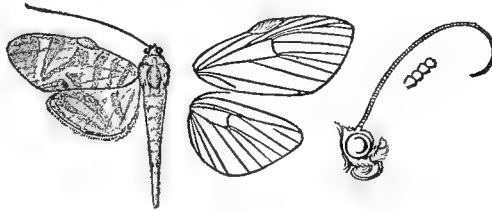

Spilomela perspicata, ♂. †.

SECT. I. Fore wing of male with a roughly scaled glandular swelling at middle of costa.

Type. (1) SPILOMELA PERSPICATA Fabr. Mant. ii. 213. S. America.
Phalcena stygialis Stoll, Pap. Exot. v. p. 56, pl. 12. f. 7.

SECT. II. Fore wing of male normal.

(2) SPILOMELA FIMBRIAURALIS Guen. Delt. & Pyr. p. 319.
 W. Indies; Brazil.

Genus 49. MACARETÆRA.

Macaretæra Meyr. Trans. Ent. Soc. 1886, p. 255.

Trichoptychodes Swinh. A. M. N. H. (6) xiv. p. 207 (1894).

Palpi upturned, conically scaled, flattened, and reaching vertex of head; maxillary palpi filiform; frons flat and oblique; antennæ

Fig. 49.

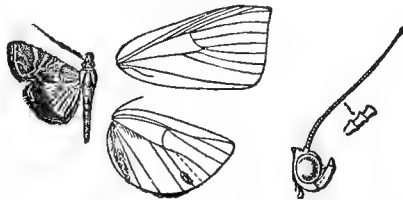

Macaretæra hesperis, ♂. †. (From Moths Ind. vol. iv.)

annulated; tibiæ slightly fringed with hair on outer sides, the outer spurs about half the length of inner. Fore wing with vein

3 from before angle of cell; 4, 5 from angle; 7 straight and well separated from 8, 9, to which 10 is approximated. Hind wing with the median nervure pectinated above; vein 1 *a* in male with a thick ridge of scales above; the cell about half the length of wing; vein 3 from angle, in male with a small tuft of scales below near the margin; veins 3, 4 stalked, in male 4 almost obsolete; 6, 7 from upper angle, 7 anastomosing with 8.

Type. MACARETERA HESPERIS Meyr. Trans. Ent. Soc. 1886, p. 255.
Assam; Fiji.
Trichoptychodes delicata Swinh. A. M. N. H. (6) xiv. p. 207.

Genus 50. ACRIDURA.

Acridura Butl. A. M. N. H. (4) xv. p. 398 (1875).

Palpi upturned, conically scaled, and not reaching vertex of head; maxillary palpi filiform; frons with a rounded projection; tibiae with the outer spurs half the length of inner; abdomen long, with very long anal tuft in male; both wings with the interspaces hyaline. Fore wing with veins 3, 4, 5 from angle of cell; 7 curved and approximated to 8, 9, to which 10 is approximated. Hind wing with veins 3, 4, 5 approximated for a short distance; 6, 7 stalked, 7 anastomosing with 8.

Fig. 50.

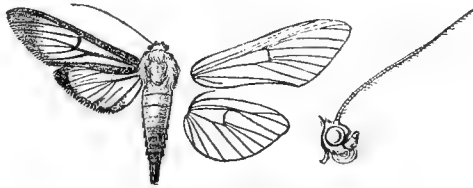

Acridura gryllina, ♂. †.

SECT. I. Antennæ of male contorted and with two scale-teeth above at middle followed by rough scales; hind wing triangular and lobed at anal angle.

(1)*ACRIDURA DÆDALA Druce, Biol. Centr.-Am., Het. ii. p. 227,
pl. 61. f. 24. Panama.

SECT. II. Antennæ of male knotted and contorted at middle, with one scale-tooth above followed by a series of spines; hind wing triangular and lobed at anal angle.

(2)*ACRIDURA HADRIANA Druce, Biol. Centr.-Am., Het. ii. p. 227,
pl. 61. f. 25. Mexico; Centr. Am.

SECT. III. Antennæ of male with the medial portion fringed with thick scales.

(3)†ACRIDURA METALLICA Butl. A. M. N. H. (4) xv. p. 399. Brazil.

(4)*ACRIDURA PROCHYTA Druce, Biol. Centr.-Am., Het. ii. p. 227,
pl. 61. f. 23. Mexico.

SECT. IV. Antennæ of male ciliated.

Type. (5)†*ACRIDURA GRILLINA* Butl. A. M. N. H. (4) xv. p. 398.

Ecuador; Brazil.

Phryctena glaucopidalis Oberth. Et. Ent. vi. p. 114, pl. 20. f. 4.

Genus 51. *FILODES*.

Filodes Guen. Delt. & Pyr. p. 317 (1854).

Pinacia Hübn. Samml. Eur. Schmett. iv. 4. p. 15 (1832),
non descr.

Auxomitia Led. Wien. Ent. Mon. 1863, p. 391.

Palpi upturned, conically scaled, and hardly reaching vertex of head; maxillary palpi filiform; frons with a rounded prominence; antennæ nearly one and a half times length of fore wing and minutely annulated; tarsi very long; abdomen long, with lateral tufts on terminal segments; the anal tuft of male thick. Fore wing with the costa highly arched towards apex; veins 3, 4, 5 from angle of cell; 7 curved and approximated to 8, 9, to which 10 also is closely approximated. Hind wing with the cell short; veins 3, 4, 5 radiating from the angle; 6, 7 on a long stalk, 7 anastomosing or in male becoming coincident with 8, 9.

Fig. 51.

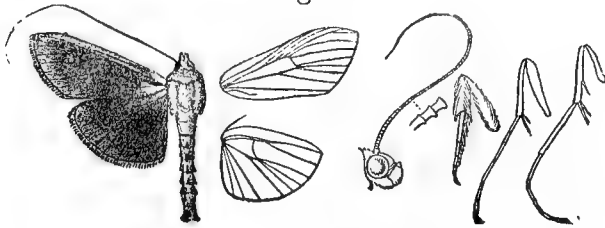

Filodes fulvidorsalis, ♂. †. (From Moths Ind. vol. iv.)

SECT. I. Hind coxæ, femora, and outer side of tibiæ of male with tufts of hair, the medial spurs absent; fore wing with vein 2 from angle of cell and approximated to 3, 4, which are distorted; hind wing with a large hyaline space below vein 6; 6, 7 on a long stalk and distorted; 5 bent downwards and running along 4.

(1)†*FILODES EOCYTUSALIS* Wlk. xviii. 540. W. Africa; Réunion.

„ *costivitalis* Guen. Réunion, p. 65.

Phryganodes abnormalis Plötz, S. E. Z. 1880, p. 305.

(2)†*FILODES PRODUCTALIS*, n. sp. (Plate L. fig. 14.)

Head orange; palpi banded with silver; antennæ brown; thorax brown; abdomen orange, with silvery dorsal patches and silvery and black lateral patches. Wings red-brown; fore wing with orange fascia on basal half of costal area; a silvery subcostal streak and short streak near base of median nervure; two black spots in cell and a discocellular lunule.

Hab. Congo; Mashonaland (*Marshall*). *Exp.* 40 mm.

SECT. II. Fore tarsi of male with the first three joints fringed with hair on inner side; hind tibiæ with the outer medial spur absent.

Type. (3) *FILODES FULVIDORSALIS* Hübn. Samml. Exot. Schmett. iv. 4. p. 15, ff. 643-644; Moore, Lep. Ceyl. iii. pl. 182, ff. 2, 2*a* (larva). Réunion; Oriental region to Sumbawa.
Auxomitia mirificalis Led. Wien. Ent. Mon. 1863, p. 391, pl. 13. f. 1 (var.).
Filodes patruelis Moore, Lep. Atk. p. 218.

(4) *FILODES SEXPUNCTALIS* Snell. Trans. Ent. Soc. 1890, p. 603, pl. xx. ff. 6, 6*a*. Sikkim.

(5) *FILODES FULVIBASALIS*, n. sp. (Plate L. fig. 10.)

Head, thorax, and abdomen orange; palpi, frons, and pectus leaden fuscous; antennæ fuscous; abdomen with dorsal series of leaden fuscous spots, the ventral surface leaden. Fore wing fuscous with the basal third orange, its outer edge angled on median nervure and with a black spot in cell; a black spot at base of cell and another on discocellulars, with a more or less developed orange streak before it. Hind wing with the basal half orange, its outer edge oblique and terminating near anal angle, the outer half fuscous.

Hab. Tenimber (*Doherty*); Queensland (*Meek*). *Exp.* 32 mm. Types in Coll. Rothschild and B.M.

SECT. III. Fore tarsi of male naked; hind tibiæ with the outer medial spur about one-fifth inner.

(6)†*FILODES XANTHALIS*, n. sp. (Plate L. fig. 11.)

Orange-yellow; head fuscous black; male with the genital tufts white. Fore wing with the costal area fuscous; the terminal area fuscous from two-thirds of costa to inner margin near tornus. Hind wing with terminal fuscous line expanding into a patch at apex.

Hab. N. Guinea, Humboldt Bay (*Doherty*); Fergusson and Trobriand Is. (*Meek*). *Exp.* 40 mm.

Genus 52. TYSPANODES.

Tyspanodes Warr. A. M. N. H. (6) vii. p. 425 (1891).

Peribona Snell. Tijd. v. Ent. 1894, p. 43.

Radiatorista Warr. A. M. N. H. (6) xvii. p. 138.

Palpi upturned, conically scaled, and hardly reaching vertex of head; maxillary palpi filiform; frons flat and oblique; antennæ almost simple. Fore wing with veins 3, 4, 5 from angle of cell; 7 straight and well separated from 8, 9, to which 10 is approximated. Hind wing with vein 3 from angle of cell; 4, 5 closely

approximated for a short distance; 6, 7 from upper angle, 7 anastomosing with 8.

Fig. 52.

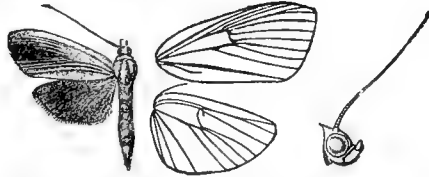

Tyspanodes fascialis, ♂. †. (From Moths Ind. vol. iv.)

SECT. I. (*Peribona*). Antennæ of male with a sinus and four or five corneous teeth at base of shaft.

(1)†TYSpanodes VENOSA Butl. Ill. Het. vii. p. 98, pl. 135. f. 10.
Himalayas; Java.

SECT. II. (*Tyspanodes*). Antennæ of male normal.

A. Fore wing with veins 4, 5 closely approximated for a short distance; vein 6 slightly bent downwards, and vein 7 upwards at base.

(2)†TYSpanodes CREAGHI, n. sp. (Plate L. fig. 7.)

♂. Ochreous yellow; tegulæ with patches of opalescent blue; shoulders, patagia, and thorax streaked with blue; pectus and ventral surface of abdomen white. Fore wing with pale blue streaks below base of costa and cell; some fuscous in and below cell, and fuscous streaks at base and on medial part of inner margin; the veins of outer area streaked with black; the interspaces above vein 2 semihyaline, with short black streaks towards termen. Hind wing semihyaline yellow with a fuscous tinge.

♀ yellower, with hardly a trace of the fuscous markings.

Hab. Sandakan, Borneo (*C. V. Creagh*). *Exp.* 20 mm.

B. Fore wing with veins 4, 5 not approximated.

(3)†TYSpanodes LINEALIS Moore, P. Z. S. 1867, p. 665, pl. 33.
f. 17. Himalayas; Ceylon; Andamans.

(4)†TYSpanodes HYPsalIS Warr. A. M. N. H. (6) vii. p. 426.
China.

(5)†TYSpanodes FLAVIVENTER Warr. A. M. N. H. (6) vii. p. 425.
Sikhim.

(6)†TYSpanodes STRIATA Butl. Ill. Het. iii. p. 76, pl. 59. f. 10.
Japan; China.

(7)*TYSpanodes EXATHESALIS Wlk. xix. 978. Borneo.

Type. (8) TYSpanodes NIGROLINEALIS Moore, P. Z. S. 1867, p. 95.
Sikhim.

(9)†*TYSPANODES FASCIALIS* Moore, P. Z. S. 1867, p. 665.

N.E. India.

(10)**TYSPANODES CARDINALIS* Hmps. Moths Ind. iv. p. 299.

Assam.

Auctorum.

Filodes flavolimbalis, Snell. Tijd. v. Ent. xxxviii. p. 127. Java.

Genus 53. *CONCHYLODES*.

Conchylodes Guen. Delt. & Pyr. p. 288 (1854).

Ledereria Snell. Tijd. v. Ent. 1875, p. 256.

Palpi upturned, conically scaled, and reaching vertex of head; maxillary palpi filiform; frons flat and oblique; antennæ of male minutely ciliated; tibiæ with the outer spurs half the length of inner. Fore wing with veins 3, 4, 5 from angle of cell; 10 closely approximated to 8, 9. Hind wing with veins 3, 4, 5 from angle of cell; 6, 7 shortly stalked, 7 anastomosing with 8.

Fig. 53.

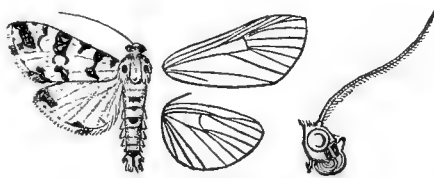

Conchylodes diphteralis, ♂. †.

SECT. I. Fore wing with vein 7 curved and approximated to 8, 9.

Type. (1) *CONCHYLODES DIPHTERALIS* Geyer, Zutr. 24. 346. ff. 691, 692. Jamaica.

(2) *CONCHYLODES HEBRÆALIS* Guen. Delt. & Pyr. p. 288.

St. Domingo.

(3)**CONCHYLODES SALAMISALIS* Druce, Biol. Centr.-Am., Het. ii. p. 251, pl. 62. f. 19. Mexico; Centr. Am.; Ecuador.

(4)†*CONCHYLODES BRYOPHILALIS*, n. sp. (Plate L. fig. 6.)

♂. Head black and white; thorax black and yellowish white, with some rufous on patagia; legs whitish ringed with black; abdomen whitish, with black marks on three basal and on the anal segment, the medial segments tinged with rufous. Fore wing yellowish white, with triangular black subbasal costal mark followed by some rufous; an antemedial black band constricted at middle and narrowing to inner margin; a medial triangular costal mark, and a large patch beyond the middle embracing the two white disco-cellular spots; a very irregular postmedial line arising from a triangular costal patch conjoined to an irregular patch from apex, then running nearly to inner margin, retracted to lower angle of cell, and reaching middle of inner margin, where it expands into a patch connected with its outer loop, broad rufous

suffusion on outer side of the line; two pale specks on apical black patch; black patches and spots on outer margin. Hind wing white, with black specks at and beyond lower angle of cell; a postmedial series of specks; a fuscous apical patch and a black marginal mark below middle, and a spot near anal angle.

Hab. Ecuador. *Exp.* 36 mm.

- (5) CONCHYLODES NOLKENIALIS Snell. Tijds. v. Ent. 1875, p. 257,
pl. 14. f. 11. Brazil.

SECT. II. Fore wing with vein 7 straight and well separated
from 8, 9.

- (6) CONCHYLODES ZEBRA Sepp, Surinam, ii. p. 221, pl. 99.
Surinam.
- (7)*CONCHYLODES STRIGINALIS Guen. Delt. & Pyr. p. 281, pl. 7.
f. 9. Brazil.
- (8) CONCHYLODES ARGENTALIS Cram. Pap. Exot. iv. p. 161, pl. 371.
f. M. S. America.
Zebronia erminea Feld. Reis. Nov. pl. 135. f. 7.

- (9)†CONCHYLODES CONCINNALIS, n. sp.

♂. Cretaceous white; black spots at base of palpi, on prothorax and 2nd and 4th segments of abdomen; the two subterminal segments orange; the anal segment white, with a black dorsal streak. Fore wing with subbasal and antemedial black bands; a spot in cell with small white centre, and larger discocellular spot with much larger centre; the postmedial line nearly straight to vein 1, then retracted to lower angle of cell and reaching inner margin before middle; a nearly straight submarginal and a marginal line. Hind wing with antemedial line; the postmedial line recurved at vein 1 and towards lower angle of cell; a nearly straight submarginal and a marginal line.

Hab. U.S.A. *Exp.* 24 mm.

- (10) CONCHYLODES PLATINALIS Guen. Delt. & Pyr. p. 282.
†*Zebronia erinalis* Wlk. xvii. 474. S. America.
,, *magicalis* Feld. Reis. Nov. pl. 135. f. 6.
- (11) CONCHYLODES OVULALIS Guen. Delt. & Pyr. p. 283.
U.S.A.; Brazil.
- (12)†CONCHYLODES HEDONIALIS Wlk. xvii. 470. W. Indies.

Genus 54. NEVRINA.

Nevrina Guen. Delt. & Pyr. p. 313 (1854).

Euglyphis Hübn. Verz. p. 341 (1827), non descr.

Palpi upturned, the 2nd and 3rd joints conically scaled and not reaching vertex of head; maxillary palpi filiform; frons rounded; antennæ nearly simple, and minutely annulated towards extremity;

tibiæ with the outer spurs half the length of inner; fore tibiæ fringed with hair, mid tibiæ clothed with rough hair on outer side, and hind tibiæ with a tuft of long hair on outer side near base; abdomen long; male with the anal tuft large. Fore wing with the costa arched towards apex, the outer margin oblique; veins 3, 4, 5 radiating from angle of cell; 7 curved and approximated to 8, 9, to which 10 is closely approximated. Hind wing with vein 3 from angle of cell; 4, 5 closely approximated for a short distance; 6, 7 from upper angle, 7 anastomosing with 8.

Fig. 54.



Nevrina procofia, ♂. †. (From Moths Ind. vol. iv.)

Type. NEVRINA PROCOPIA Cram. Pap. Exot. iv. pl. 368. f. E.

Oriental region.

Genus 55. DICHOGAMA.

Dichogama Led. Wien. Ent. Mon. 1863, p. 396.

Carbacha Wlk. xxiv. 1379 (1865).

Pleurasympieza Möschl. Lep. Porto Rico, p. 146 (1889).

Palpi upturned, conically scaled, thin, flattened against the frons, and not reaching vertex of head; maxillary palpi filiform; frons rounded; antennæ of male ciliated; tibiæ with the spurs long and almost equal; abdomen with the anal tuft large. Fore wing with vein 3 from before angle of cell; 4, 5 from angle; 7 straight and well separated from 8, 9, to which 10 is approximated. Hind wing with vein 3 from angle of cell; 4, 5 approximated for a short distance; 6, 7 from upper angle, 7 anastomosing with 8.

Fig. 55.

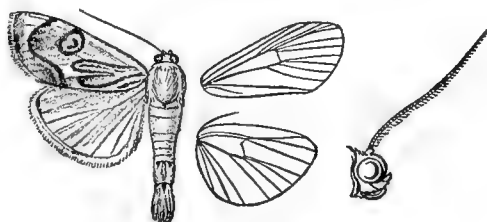

Dichogama redtenbacheri, ♂. †.

(1) † DICHOGAMA DECORALIS Wlk. xxxiv. 1380.

St. Domingo.

(2) DICHOGAMA INNOCUA Fabr. Ent. Syst. iii. 1, p. 461 (1793).

W. Indies.

„ *krugii* Möschl. Lep. Porto Rico, p. 296, f. 2.

Type. (3) *DICHOGAMA REDTENBACHERI* Led. Wien. Ent. Mon. 1863, p. 396, pl. 10. f. 11. W. Indies.

(4) *DICHOGAMA SMITHI* Möschl. Lep. Porto Rico, p. 147. W. Indies.

Auctorum.

Dichogama amabilis Möschl. Lep. Porto Rico, p. 296. W. Indies.
 „ *fernaldi* Möschl. Lep. Porto Rico, p. 297. Porto Rico.
 „ *bergii* Möschl. Lep. Porto Rico, p. 297. Porto Rico.
 „ *gudmanni* Hedemann, Stett. Ent. Zeit. lv. p. 29. St. Jan.

Genus 56. *PHRYGANODES*.

Phostria Hübn. Verz. p. 130 (1827), non descr.

Phryganodes Guen. Delt. & Pyr. p. 353 (1854).

Omiodes Guen. Delt. & Pyr. p. 355.

Eporidia Wlk. xviii. 541 (1859).

Cirrocephala Led. Wien. Ent. Mon. 1863, p. 395.

Spargeta Led. Wien. Ent. Mon. 1863, p. 406.

Cænostola Led. Wien. Ent. Mon. 1863, p. 409.

Microthyris Led. Wien. Ent. Mon. 1863, p. 433.

Nagia Wlk. xxxiv. 1320 (1865).

Vatica Wlk. Proc. N. H. Soc. Glasg. vol. i. p. 369 (1869).

Condega Moore, Lep. Ceyl. iii. p. 344 (1886).

Charema Moore, Lep. Atk. p. 218 (1887).

Saroscelis Meyr. Trans. Ent. Soc. 1894, p. 461.

Palpi upturned and reaching vertex of head, the 2nd and 3rd joints conically scaled and tapering to apex; maxillary palpi filiform; frons rounded; antennæ nearly as long as the fore wing and minutely ciliated; tibiæ with the outer spurs about half the length of inner; abdomen long. Fore wing with the costa arched towards apex, which is somewhat produced; the outer margin

Fig. 56.

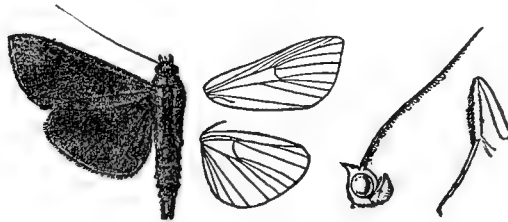

Phryganodes noctescens, ♂. †. (From Moths Ind. vol. iv.)

obliquely rounded, the inner margin somewhat lobed towards base; veins 3, 4, 5 from angle of cell; 7 curved and approximated to 8, 9 for about one-third length; 10 also closely approximated to 8, 9. Hind wing with the costa arched at middle; the cell short; veins 3, 4, 5 from angle of cell; 6, 7 from upper angle or shortly stalked, 7 anastomosing with 8.

SECT. I. (*Condega*). Antennæ of male with the base of shaft greatly excised; patagia with tufts of long hair extending beyond the metathorax.

- (1)†PHRYGANODES OBSCURATA Moore, Lep. Ceyl. iii. p. 345, pl. 183.
f. 12. India; Ceylon; Burma.

SECT. II. Antennæ of male with the basal joint greatly dilated and bearing tufts of hair; the base of shaft excised; the patagia short.

- (2)†PHRYGANODES RADICALIS Wlk. xxiv. 1417. Ceram.

- (3)†PHRYGANODES EREBUSALIS, n. sp.

♂. Deep black-brown, with a slight purplish gloss; the small distal tuft on basal joint of antennæ fulvous; abdomen grey below. Fore wing with indistinct curved antemedial line, a discocellular lunule, and postmedial line bent outwards between veins 5 and 2, then retracted to below angle of cell.

Hab. Sierra Leone (*Clements*). *Exp.* 34 mm. Types in B.M. and Coll. Schaus.

SECT. III. Antennæ of male with large tuft of scales beyond middle; mid tibiæ clothed with long rough hair; hind tibiæ shortened, with tufts of hair, the spurs and tarsus fringed with long hair.

- (4)*PHRYGANODES NUBILIS Feld. Reis. Nov. pl. 136. f. 21.
Moluccas.

SECT. IV. (*Microthyris*). Antennæ of male thickened with scales beyond middle; patagia long; hind tibiæ with thick tufts of hair.

- (5) PHRYGANODES PROLONGALIS Guen. Delt. & Pyr. p. 353.
Botys sectalis Guen. Delt. & Pyr. p. 353. W. Indies; S. Am.
† „ *eurytalis* Wlk. xviii. 576.
„ *agenoralis* Wlk. xviii. 617.

SECT. V. (*Spargeta*). Antennæ of male with scale-teeth on basal third above, then slightly contorted.

- (6) PHRYGANODES BASALTICALIS Led. Wien. Ent. Mon. 1863,
p. 407, pl. 14. f. 11. Amboina; Aru; New Britain.
Botys amplipennis Butl. A. M. N. H. 1882, ii. p. 237.

SECT. VI. Antennæ annulate and longer than fore wing, which is long and narrow, the apex produced and acute.

- (6a) PHRYGANODES PRODUCTALIS, n. sp.

♂. Pale yellowish fuscous; palpi with black band on 2nd joint, white towards extremity; legs and ventral surface of

abdomen whitish. Fore wing with the costa rather darker; cilia of both wings white at tips.

Hab. Surinam (*Ellacombe*). *Exp.* 26 mm. Types in coll. Rothschild and B.M.

SECT. VII. Antennæ of male normal.

A. Hind tibiæ of male with a curved process on outer side near base, the inner medial spur pectinated with long spines.

- (7) PHRYGANODES MILVALIS Druce, Biol. Centr.-Am., Het. ii. p. 253, pl. 62. f. 21. Centr. Am.

B. (*Phostria*). Hind tibiæ of male tufted with hair.

a. Mid and hind tarsus of male fringed with hair.

- (8)†PHRYGANODES ORIGOALIS Wlk. xviii. 681. Borneo; Celebes. *Omiodes nigriscripta* Warr. A. M. N. H. (6) xvii. p. 132.

b. Tarsi of male naked.

a'. Fore tibiæ with a groove containing a tuft of hair; mid tibiæ with thick tufts of hair; hind tibiæ shortened, dilated, and with thick tufts of hair, the inner spurs extremely long, the terminal pair and the tarsus fringed with long hair.

- (9) PHRYGANODES LONGIPENNIS Warr. A. M. N. H. (6) xvii. p. 132. Assam; Andamans.

b'. Hind tarsi naked.

a². Mid and hind femora fringed with long hair.

- (10) PHRYGANODES TEDEA Cram. Pap. Exot. iv. p. 48, pl. 312. f. G. Mexico; C. & S. America.
†*Botys oajacalis* Wlk. xxxiv. 1393.
,, *pelialis* Feld. Reis. Nov. pl. 135. f. 46.

- (11) PHRYGANODES TEMIRA Cram. Pap. Exot. iv. p. 160, pl. 371. f. E (♀). Brazil.

- (12) PHRYGANODES PERSIUSALIS Wlk. xviii. 623 (♀). Brazil.
†*Phostria confluentalis* Warr. Trans. Ent. Soc. 1889, p. 277.

- (13) PHRYGANODES VARIALIS Wlk. Trans. Ent. Soc. ser. 3, i. p. 122 (♀). Brazil.

b². Mid femora of male fringed with hair; hind tibiæ with tufts on inner and outer side at base only.

- (14)*PHRYGANODES LITHOSIALIS Guen. Delt. & Pyr. p. 325. Brazil.

- (15)†PHRYGANODES PERFULVALIS, n. sp. (Plate XLIX. fig. 16.)
Bright orange-red; palpi whitish, fuscous at tips; anal tuft

fuscous at extremity. Fore wing with the terminal third fuscous, with a large white patch on its inner edge beyond the cell between veins 2 and 7, and with a curved fuscous streak on its lower edge extending almost to cell; a tridentate subapical white mark and a slight mark above tornus. Hind wing with apical fuscous patch and streaks on the veins of terminal area separated by white marks, the streak on vein 2 longer.

Hab. Peru: Huambo, Chachapoyas. *Exp.* 38 mm.

c^2 (*Saroscelis*). Mid and hind femora not fringed with hair.

a^3 . Hind tibia of male strongly curved at middle and fringed with short hair on outer side, long hair on inner, the inner spurs extremely long.

(16) *PHRYGANODES NICOALIS* Wlk. xviii. 700.

Singapore; Borneo; Sumbawa.

b^3 . Hind tibia of male not curved.

(17)†*PHRYGANODES MARGARITA* Butl. A. M. N. H. 1887, ii. p. 120.
Solomons.

(18)†*PHRYGANODES ATTENUATA*, n. sp.

♂. Fore coxæ, femora and tibiæ, and mid and hind tibiæ fringed with long hair. Dark fuscous; abdomen with the ventral surface whitish. Fore wing long and narrow; an obscure sinuous antemedial line; a discoidal spot; an obliquely curved postmedial line angled inwards at vein 2. Hind wing with obscure curved medial line.

Hab. Amboina; Bourou (*Doherty*). *Exp.* 40 mm.

C. Hind legs of male with large tufts of black hair from origin of coxæ.

(19)†*PHRYGANODES DIFFUSIMARGINALIS*, n. sp.

Ochreous yellow; abdomen fuscous at extremity. Fore wing with diffused fuscous on costal area covering the whole cell; the outer area of both wings fuscous with a purplish gloss, somewhat diffused on inner edge and narrowing to anal angle of hind wing.

Hab. Pulo Laut (*Doherty*). *Exp.* 34 mm.

D. Hind tibiæ of male with very thick fringe of black hair from medial spurs to extremity; costa of fore wing with immense tuft of flocculent hair covered by large flattened scales on basal half below and somewhat excised at middle.

(20)†*PHRYGANODES FLOCCULENTALIS*, n. sp. (Plate L. fig. 4.)

♂. Fuscous; abdomen with dorsal black bands on medial segments. Fore wing with indistinct dark antemedial line; a discocellular black spot; a postmedial line straight from costa to vein 2, then retracted to lower angle of cell and excurved again.

Hind wing with black discocellular spot; a dark postmedial line. straight from costa to vein 2, then retracted to lower angle of cell.

Hab. Kulu, N.W. Himalayas; Pulo Laut (*Doherty*). *Exp.* 26 mm.

E. Hind tibiæ of male with rounded corneous swelling on inner side near base, the inner medial spur dilated at extremity.

(21)†PHRYGANODES TETRAPLAGALIS, n. sp.

Greyish fuscous shot with brilliant purple; throat white. Fore wing with oblique pearly-white bar beyond the cell between veins 3 and 7, often broader and somewhat wedge-shaped. Hind wing with patch in and beyond end of cell, which may be large or rounded, wedge-shaped, or elongate.

Hab. Humboldt Bay (*Doherty*), Fergusson I. (*Meek*), N. Guinea. *Exp.* 38 mm.

(22)†PHRYGANODES REGALIS Butl. A. M. N. H. (5) x. p. 236 (1882).
N. Britain.

(23)†PHRYGANODES CENTRALBALIS, n. sp. (Plate XLIX. fig. 17.)

♀. Black, with slight purple tinge; palpi at base, pectus, and ventral surface of abdomen white; legs whitish. Fore wing with semicircular white patch on middle of inner margin. Hind wing with large pearly-white discal patch extending to costa. Under-side of fore wing with obscured curved black postmedial line.

Hab. Fergusson I., N. Guinea (*Meek*). *Exp.* 38 mm.

F. Fore tibiæ of male and 1st two tarsal joints with immense tufts of hairs; mid and hind femora and mid tibiæ thickly fringed with hair; fore wing with tuft of hair on upper-side below middle of costa; hind wing with fringes of woolly hair on inner area above and below.

(24)†PHRYGANODES LANIALIS, n. sp. (Plate XLIX. fig. 19.)

Fuscous; antennæ and vertex of head with a slight rufous tinge; genital tufts of male whitish. Fore wing with ante-medial black line angled on median nervure and bent outwards to inner margin: both wings with a discoidal spot; the postmedial line bent outwards and dentate between veins 5 and 2; a slight marginal series of points.

Hab. Fergusson I., N. Guinea (*Meek*). *Exp.* 44 mm.

G. Hind tibiæ of male short, the tarsus long and fringed with very long hair above; thorax with tuft of hair from base of fore wing; inner margin of hind wing fringed with thick hair.

(25)†PHRYGANODES BIGUTTATA, n. sp. (Plate XLIX. fig. 21.)

♂. Head, tegulæ, and base of patagia orange; thorax and abdomen grey-white, the pectus and ventral surface orange.

Fore wing grey-white, with black spots below cell near base and on discocellulars. Hind wing white, the inner area yellowish; a fuscous apical patch tapering from costa to vein 2.

Hab. Sierra Leone (*Clements*). *Exp.* 30 mm.

H. Hind tarsi of male with immense tufts of hair; fore wing with the inner margin strongly lobed and with elongate lunulate patch of androconia on underside.

(26)†*PHRYGANODES HESUSALIS* Wlk. xviii. 642. W. Africa.

I. Legs of male normal.

a. Thorax of male with tuft of long stiff hair from base of hind wing.

(27)†*PHRYGANODES SETIFERA*, n. sp.

Pale greyish brown; base of palpi, pectus, legs, and ventral surface of abdomen whitish; wings with the veins rather darker. Hind wing thinly scaled; the underside whitish, except the cilia.

Hab. Fergusson I., N. Guinea (*Meek*). *Exp.* ♂ 40, ♀ 46 mm.

(27a)†*PHRYGANODES ALBIRENALIS*, n. sp.

♂. Fuscous with a bronze tinge; palpi at base, pectus, and ventral surface of abdomen white; the tufts on thorax black and white. Fore wing with a dark discoidal lunule, with prominent white spots beyond it. Hind wing with the tornus produced to a lobe; a pale line at base of cilia.

♀ duller fuscous; hind wing with the tornus not produced.

Hab. Brazil, Rio Demerara, ♂ in Coll. Rothschild; Brèves (*Austen*), ♀ type. *Exp.* 24 mm.

b. Thorax of male normal.

a¹. (*Phryganodes*). Fore wing of male with an elongate depression beyond the cell extending to outer margin, the neuration distorted; the inner margin much lobed near base; vein 1 a running into 1 b; hind wing with a large fovea below base of cell, the neuration much distorted and the anal angle lobed.

Type. (28) *PHRYGANODES PLICATALIS* Guen. Delt. & Pyr. p. 353, pl. 10. f. 6. Brazil.

b¹. (*Cirrocephala*). Fore wing of male with depressed streaks below bases of veins 2 and 3, the neuration distorted, and a small tooth on base of vein 3 below.

(29)**PHRYGANODES EUCHARISALIS* Wlk. xviii. 618.

W. Indies; Brazil.

Cirrocephala venosa Led. Wien. Ent. Mon. 1363, p. 395.

(30)**PHRYGANODES PURPURALIS* Druce, Biol. Centr.-Am., Het. ii. p. 226, pl. 61. f. 21 (♀). Costa Rica.

*c*¹. Fore wing of male with a fringe of long hair on base of costa below; median nervure fringed with upturned hair; the costa excised before middle and towards apex, which is produced and falcate.

(31) PHRYGANODES XIPHARESALIS Wlk. xviii. 687. Borneo.

*d*¹. Fore wing of male with the base of costa extremely dilated and contorted, the underside with fringes and tufts of hair.

(32)†PHRYGANODES OMPHALOBASIS, n. sp. (Plate XLIX. fig. 20.)

♂. Fuscous grey; palpi at base, pectus, and ventral surface of abdomen white. Fore wing with obscure discoidal spot and post-medial line excurved to vein 3, then retracted; underside whitish.

Hab. Venezuela, Aroa. *Exp.* 34 mm. Types in B.M. and Coll. Schaus.

*e*¹. Fore wing of male with a thick ridge of large scales concealing tufts of long hair on basal half of costa below.

(33)*PHRYGANODES PACHYCRASPEDALIS Hmpsn. Moths Ind. iv. p. 302. Assam.

*f*¹. Fore wing of male with a large tuft of long hair from base of costa below.

(34)*PHRYGANODES LOPHOPHORALIS Hmpsn. Moths Ind. iv. p. 302. Sikhim.

*g*¹. (*Vatica*). Hind wing of male with a fringe of long hair below the cell above.

(35)†PHRYGANODES RUTILALIS Wlk. Proc. N. H. Soc. Glasg. i. p. 369. W. Africa.

*h*¹. Hind wing of male with the anal angle lobed.

(36)*PHRYGANODES CAPILLALIS Guen. Delt. & Pyr. p. 335. Cayenne.

*i*¹. Hind wing of male with the cell extremely short and broad.

(37)*PHRYGANODES CONCOLOR Feld. Reis. Nov. pl. 136. f. 24. Moluccas.

*j*¹. Wings normal.

*a*². (*Omiodes*). Patagia of male extending far beyond metathorax.

(38)†PHRYGANODES NOCTESCENS Moore, Lep. Atk. p. 218. N.E. India. 46*

- (39) PHRYGANODES INSOLUTALIS Möschl. Abh. 'Senck. Ges. xvi.
p. 301. Porto Rico; Venezuela.
- (40)†PHRYGANODES FULVICAUDA, n. sp.
♂. Greyish fuscous with a purplish tinge; palpi, pectus, legs, ventral surface of abdomen and last two segments above orange; head tinged with orange; anal tuft black. Fore wing with indistinct fuscous antemedial line: both wings with discoidal spot and postmedial line retracted at vein 2 to below angle of cell; cilia pure white at tips.
Hab. Venezuela, Aroa. *Exp.* 42 mm.
- (41) PHRYGANODES HUMERALIS Guen. Delt. & Pyr. p. 356.
†*Botys peleusalis* Wlk. xviii. 575. St. Domingo.
† „ *gnomalis* Wlk. xviii. 580.
- (42)*PHRYGANODES CUNICULALIS Guen. Delt. & Pyr. p. 356, pl. 5.
f. 9. Brazil.
Omiodes leporalis Guen. Delt. & Pyr. p. 357.
- (43) PHRYGANODES PALLIVENTRALIS Snell. Trans. Ent. Soc. 1890,
p. 620. N.E. India.
- (44) PHRYGANODES ANALIS Snell. Tijd. v. Ent. 1879, p. 227.
N.E. India; Pulo Laut; Celebes; Duke of York Isl.
†*Charema albociliata* Moore, Lep. Atk. p. 219.
†*Omiodes hiracia* Meyr. Trans. Ent. Soc. 1894, p. 457.
- (45) PHRYGANODES CRITHIONALIS Wlk. xviii. 682.
Assam; Borneo; Java; Amboina.
Polythlipta caradrinalis Snell. Tijd. v. Ent. xxxv. p. 162,
pl. 10. f. 7.
- (46)*PHRYGANODES OCHROSOMA Feld. Reis. Nov. pl. 136. f. 5.
Brazil.
- (47)†PHRYGANODES PIASUSALIS Wlk. xviii. 725. Madagascar;
†*Botys retractalis* Wlk. xxxiv. 1447. Java; Australia.
- b^2 . (*Eporidia*). Patagia of male hardly extending beyond metathorax.
- a^3 . Abdomen of male with the 3rd and 4th segments produced laterally into large recurved hollowed-out processes.
- (48)†PHRYGANODES HAMIFERALIS, n. sp.
♂. Fuscous; pectus, legs, and underside of abdomen whitish. Fore wing with traces of sinuous antemedial line, discoidal speck, and postmedial line excurved from costa to vein 2, where it is retracted to below angle of cell. Hind wing with traces of oblique postmedial line from below costa to vein 2.
Hab. N. Guinea, Kapaur (*Doherty*). *Exp.* 24 mm.

- (49) PHRYGANODES DISPILOTALIS Wlk. xxxiv. 1487.
Sula; Celebes; Australia.
Omiodes palliostalis Snell. Tijds. v. Ent. 1880, p. 226, & 1884,
pl. 3. f. 3.
Conogethes lictor Meyr. Trans. Ent. Soc. 1887, p. 227.
- (50)†PHRYGANODES MACULICOSTALIS Hmps. Ill. Het. ix. p. 171,
pl. 172. f. 12. N.E. India; Ceylon.
- (51) PHRYGANODES SIMIALIS Guen. Delt. & Pyr. p. 357.
†*Botys jasonalis* Wlk. xviii. 575. W. Indies; S. America.
† „ *orontesalis*, Wlk. xviii. 614.
Cœnostola eruptalis Led. Wien. Ent. Mon. 1863, p. 409,
pl. 15. f. 1.
- (52) PHRYGANODES APICALIS Led. Wien. Ent. Mon. 1863, p. 409,
pl. 14. f. 16. Brazil.
- (53)†PHRYGANODES MIMASTIS Meyr. Trans. Ent. Soc. 1897, p. 88.
Sangir.
- (54)†PHRYGANODES DELILALIS Wlk. xvii. 376. Brazil.
Botys atyriasis Feld. Reis. Nov. pl. 135. f. 30.
- (55)*PHRYGANODES CROCEICEPS Wlk. xxxiv. 1375; Feld. Reis.
Nov. pl. 136. f. 31. Brazil.
- (56)*PHRYGANODES EUAGRA Feld. Reis. Nov. pl. 136. f. 34.
Brazil.
- (57)†PHRYGANODES QUADRIGUTTATA Wlk. Pr. Glasg. Soc. N. H.
p. 336. W. Africa.
- (58) PHRYGANODES GLYPHODALIS Wlk. xxxiv. 1488. E. Himalayas;
Ceylon; Burma; Sula.
- (59)†PHRYGANODES DARIUSALIS Wlk. xviii. 541. W. Africa.
- (60)†PHRYGANODES ODONTOSTICTA, n. sp.
Reddish brown suffused with grey; palpi at base and throat
white; tarsi and mid tibiæ white; abdomen banded with white
below. Fore wing with small silvery semihyaline white spot
above base of vein 2 conjoined to a larger spot below it; a trifid
spot beyond lower angle of cell. Hind wing with a semihyaline
silvery white patch below the end of cell extending slightly into
middle of cell, with slightly dentate outer edge and conjoined to a
large patch beyond the cell, with three dentations on median
nervules; cilia white at apex, and from middle to anal angle.
Hab. Oinainisa (*Doherty*); Fergusson I., N. Guinea; Queens-
land (*Meek*). *Exp.* 24-36 mm.
- (61) PHRYGANODES UNITALIS Guen. Delt. & Pyr. p. 349.
N.E. India; Andamans; Ceram; N. Guinea.
†*Pachynoa megapteralis* Wlk. xxxiv. 1407 (part.).
Botys germanalis, Wlk. xxxiv. 1418.
†*Pachynoa opalinalis* Moore, P. Z. S. 1877, p. 620.

- (62)†*PHRYGANODES CANIUSALIS* Wlk. xviii. 638. W. Africa.
- (63) *PHRYGANODES MARTYRALIS* Led. Wien. Ent. Mon. 1863, p. 409, pl. 14. f. 15. Brazil.
- (64) *PHRYGANODES IMBECILIS* Moore, Lep. Atk. p. 219, pl. 7. f. 23. N.E. India.
Omiodes scabripennis, Warr. A. M. N. H. (6) xvii. p. 131.
- (65)**PHRYGANODES UNITINCTALIS* Hmps. Moths Ind. iv. p. 302. Burma.
- (66) *PHRYGANODES SCHEDIUSALIS* Wlk. xviii. 683. N.E. India; Andamans; Borneo.
†*Charema carbonalis* Swinh. A. M. N. H. (6) xiv. p. 202.
- (67)†*PHRYGANODES TAGIADALIS*, n. sp.

Black-brown with a slight purplish gloss; base and 3rd joint of palpi and lateral points on frons white; pectus, legs, and ventral surface of abdomen white; male with the genital tufts white. Fore wing with traces of a diffused curved dark medial line. Underside of hind wing white, with dark discoidal lunule, the apical area purplish fuscous from costa before middle to outer margin at vein 2, and with traces of a dark patch beyond the cell.

Hab. Fergusson I., New Guinea. (*Meek*). *Exp.* 36 mm.

- (68)†*PHRYGANODES ALBIPEDALIS*, n. sp.

♂. Fuscous black; edges of frons, pectus in front, tarsi, and anal tuft white; wings with purplish tinge. Fore wing with obscure discoidal spot and postmedial line retracted at vein 3 to below end of cell. Hind wing with obscure discoidal line and medial line retracted to lower angle of cell; cilia of both wings whitish at tips.

Hab. Sangir; Bourou (*Doherty*). *Exp.* 34 mm.

Auctororum.

- Plectrona dohrnii* Snell. Tijd. v. Ent. xxxviii. p. 142, pl. vi. ff. 6, 8. S. Amer.
- Omiodes heterogenalis* Brem. Mém. Acad. St. Pétersb. viii. p. 70, pl. vi. f. 11. Siberia.

Genus 57. *PROCONICA*, nov.

Palpi upturned, short, and not reaching vertex of head, the 2nd and 3rd joints conically scaled and tapering to apex; maxillary palpi filiform; frons with a large rounded prominence; antennæ of male minutely ciliated and not so long as the fore wing; mid and hind tibiæ thickly scaled, the outer medial spur about one-fourth length of inner. Fore wing with veins 3, 4, 5 from angle of cell; 7 straight and well separated from 8, 9. Hind wing with the cell less than half the length of wing; veins 3, 4, 5 from

angle; 6, 7 from upper angle or shortly stalked, 7 anastomosing with 8.

Fig. 57.

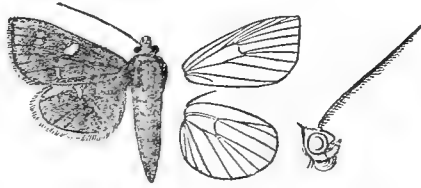

Proconica nigrocyanalisis, ♂. †.

SECT. I. Fore wing of male with the tornal area very greatly enlarged and covering a silky patch on hind wing occupying more than half the wing.

(1)**PROCONICA FLAVIGUTTALIS*, n. sp.

♂. Fuscous; abdomen with traces of fulvous bands. Fore wing with quadrate yellow discoidal spot. Hind wing with the area covered by tornal lobe of fore wing whitish.

Hab. Niger R., Warri (*Dr. Roth*), 1 ♂ type. *Exp.* 28 mm. Type in Coll. Rothschild.

SECT. II. Fore wing of male normal.

Type. (2)**PROCONICA NIGROCYANALIS*, n. sp.

♂. Black with a purplish tinge; palpi below, pectus, legs, and abdomen below white. Fore wing with very prominent quadrate white spot in cell; three postmedial white striae between vein 3 and inner margin, and two specks below costa towards apex; cilia white above outer angle. Hind wing with straight medial white line interrupted at vein 5; cilia white above anal angle.

Hab. Khâsis. *Exp.* 30 mm. Type in Coll. Rothschild.

Genus 58. OLIGOCENTRIS.

Oligocentris Hmps. Moths Ind. iv. p. 304 (1896).

Palpi upturned, the 2nd and 3rd joints conically scaled and reaching above vertex of head; maxillary palpi filiform; frons

Fig. 58.

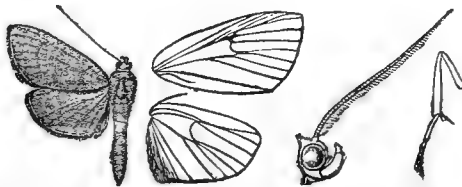

Oligocentris deciusalis, ♂. †. (From Moths Ind. vol. iv.)

rounded; antennæ of male with long cilia; male with a tuft of long hair from origin of fore wing below; mid tibiæ with the

outer spurs about half the length of inner; hind tibiæ of male with the medial spurs absent, the outer terminal spurs minute, the inner large and roughly scaled, female with the medial spurs present, the outer minute. Fore wing with the apex rectangular; vein 3 from slightly before angle of cell; 4, 5 from angle; 7 straight and well separated from 8, 9, to which 10 is approximated. Hind wing with vein 3 from angle of cell, which is nearly half the length of wing; 4, 5 approximated for a short distance; 6, 7 from upper angle, 7 anastomosing with 8; a fringe of long hair at anal angle.

Type. OLIGOCENTRIS DECIUSALIS Wlk. xviii. 1896; Hmps. Ill. Het. ix. pl. 173. f. 13. Ceylon; Palo Laut; Borneo.

Genus 59. DICHOCROCIS.

Dichocrocis Led. Wien. Ent. Mon. 1863, p. 447.

Conogethes Meyr. Trans. Ent. Soc. 1884, p. 314.

Gadessa Moore, Lep. Ceyl. iii. p. 278 (1886).

Dadessa Moore, Lep. Ceyl. iii. p. 333.

Phadropsis Warr. A. M. N. H. (6) vi. p. 476 (1890).

Orthospila Warr. A. M. N. H. (6) vi. p. 477.

Zebrodes Warr. A. M. N. H. (6) xvii. p. 104 (1896).

Palpi upturned, conically scaled, and usually hardly reaching vertex of head; maxillary palpi filiform; frons rounded; antennæ of male somewhat thickened and almost simple; tibiæ with the outer spurs less than half the length of inner; mid tibiæ fringed with spinous hair on outer side. Fore wing with veins 3, 4, 7 from angle of cell; ¹7 straight, and well separated from 8, 9; 10 approximated to 8, 9. Hind wing with vein 3 from angle of cell; 4, 5 separate at origin or slightly approximated for a short distance; 6, 7 shortly stalked, 7 anastomosing with 8.

Fig. 59.

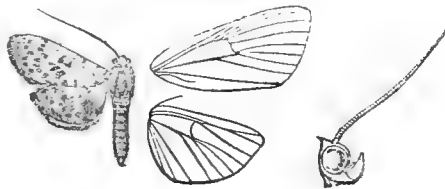

Dichocrocis punctiferalis, ♂. 1. (From Moths Ind. vol. iv.)

SECT. I. Palpi of male with the 3rd joint much longer and reaching well above vertex of head; fore wing with a fold on basal two-thirds of costa containing a fringe of long hair.

(1) DICHOCROCIS PSEUDPEONALIS, n. sp.

♂. Greyish fuscous brown; abdomen with the base of anal segment whitish. Fore wing with slightly curved fuscous ante-

¹ In *clioalis*, *punctiferalis*, *festivalis*, *spoliatalis*, and *cernatis* vein 7 is somewhat approximated to 8, 9 at base, and veins 4, 5 of hind wing somewhat approximated, especially in the males.

medial line; a discocellular lunule; a postmedial line oblique to vein 4, then retracted to near lower angle of cell. Hind wing with dark medial line oblique to above anal angle, where it is angled; a short curved line beyond the cell between veins 6 and 3; a dark marginal line.

Hab. N. Guinea, Humboldt Bay (*Doherty*). *Exp.* 24 mm. Type in Coll. Rothschild.

SECT. II. Palpi of the male with the 3rd joint normal.

A. Hind tibiæ of male thickly fringed on both sides with long hair.

- (2) *DICHOCROCIS XUTHUSALIS* Wlk. xviii. 691. Sikhim ;
Borneo ; Amboina.
Botys onusalis Snell. Trans. Ent. Soc. 1890, p. 587.

B. Hind tibiæ of male with large tuft of scales.

- (3) *DICHOCROCIS SURUSALIS* Wlk. xviii. 695. Japan ;
†*Botys subjunctalis* Wlk. xxxiv. 1404. Ceylon ; Sumatra ;
" *triferalis* Wlk. xxxiv. 1428. Borneo ; Celebes.
" *semifascialis* Snell. Tijds. v. Ent. xxiii. p. 214, & xxiv.
pl. 7. f. 12.

C. (*Dadessa*). Hind leg of male with a tuft of black hair on outer side of 1st joint of tarsus; hind wing with a small tuft of scales on upperside at origin of vein 2 and a tuft of thick short black hair on vein 1 *b* above anal angle.

- (4)†*DICHOCROCIS FLUMINALIS* Butl. A. M. N. H. (5) xi. p. 428
(1883). Fiji.
(5)†*DICHOCROCIS EVAXALIS* Wlk. xix. 995; Moore, Lep. Ceyl. iii.
pl. 183. f. 3. India ; Ceylon ; Sumatra ; Java.
Botys aureolalis Led. Wien. Ent. Mon. 1863, p. 473.
Conogethes semistrigalis Snell. Tijds. v. Ent. xxxviii. p. 128,
pl. v. ff. 6, 7.

(5a)**DICHOCROCIS XANTHOCYMA*, n. sp.

♂. Pale yellow; palpi at base, pectus, and ventral surface of abdomen white; anal tufts black. Fore wing with dentate orange subbasal and antemedial lines; a point in end of cell and discocellular spot; a waved postmedial line, excurved between veins 5 and 2, then retracted to below end of cell; a waved subterminal line. Hind wing with discoidal orange spot; a dentate postmedial line bent outwards below costa and between veins 5 and 2 and with the tufts above tornus on it; a dentate subterminal line and fine terminal line.

Hab. Moroka, Br. N. Guinea (*Anthony*). *Exp.* 38 mm. Type in Coll. Rothschild.

D. Hind leg of male normal.

a. Hind wing of male with the cell clothed with long hair below.

(6)†DICHOCROCIS BISTRIGALIS Wlk. xxxiv. 1348. N.E. India.

b. Hind wing of male normal.

a¹. (*Dichocrocis*). Abdomen of male with long protrusible upcurled anal tufts, rarely exerted.

Type. (7) DICHOCROCIS PANDAMALIS Wlk. xix. 999. Assam; Malayan
 ,, *frenatalis* Led. Wien. Ent. Mon. subregion.
 1863, p. 448, pl. 17. f. 15.

(8) DICHOCROCIS BILINEALIS Hmps. Moths Ind. iv. p. 306.

Burma.

(9) DICHOCROCIS FUSCIFIMBRIA Warr. A. M. N. H. (6) xviii.
 p. 170. N. Guinea.

b¹. (*Conogethes*). Abdomen of male with the anal tuft normal.

(10) DICHOCROCIS CLIOALIS Wlk. xviii. 549. Borneo; Pulo Laut.
Botys oryssusalis Wlk. xviii. 701.

(11) DICHOCROCIS PUNCTIFERALIS Guen. Delt. & Pyr. Japan;
 p. 320. Oriental & Australian regions.

†*Astura erscalis* Wlk. xix. 980.

†*Botys nicippealis* Wlk. xix. 999.

†*Astura guttatalis* Wlk. xxxiv. 1381.

† ,, *semifascialis* Wlk. xxxiv. 1381.

(12)†DICHOCROCIS PLUTO Butl. A. M. N. H. (5), xx. p. 121 (1887).
 Burma; Solomons.

(13) DICHOCROCIS ACTINALIS, n. sp.

♂. Bright yellow; thorax and patagia spotted with black; abdomen with a pair of black spots on basal segments; dorsal black bands on medial segments and a black patch on anal segment. Fore wing with four black spots on basal area; a straight erect antemedial black line; a spot in cell; a medial line slightly angled on median nervure; an oblique postmedial line from costa to vein 5; three submarginal streaks above vein 5, the middle one long, a line below them between veins 5 and 2, where it is retracted to the black spot at lower angle of cell, with three streaks beyond it between veins 5 and 2 and one below it above vein 1. Hind wing with slightly sinuous oblique medial line ending near anal angle and widening at middle; postmedial and submarginal broad lines coalescing at vein 2 and ending at anal angle.

Hab. Khásis. *Exp.* 22 mm. Type in Coll. Rothschild.

(14)*DICHOCROCIS SABATALIS Druce, Biol. Centr.-Am., Het. ii.
 p. 252, pl. 62. f. 18. Mexico; Centr. Am.

(15) *DICHOCROCIS TRIPUNCTAPEX*, n. sp. (Plate L. fig. 5.)

Orange, anal tuft with black point. Fore wing with indistinct sinuous antemedial line arising from a small wedge-shaped black costal spot; a large black discoidal spot; the postmedial line indistinct, arising from a costal spot, angled inwards on vein 5 and at vein 2 retracted to below end of cell; three prominent black spots on termen towards apex, with small points below and a subterminal spot near tornus. Hind wing with discoidal black point; the postmedial line very indistinct from costa to vein 2, then retracted to below angle of cell and more prominent; some black points just inside termen and a spot followed by a short line towards tornus: cilia of both wings fuscous.

Hab. Amboina (*Doherty*). *Exp.* 24 mm. Types in Coll. Rothschild and B.M.

(16) *DICHOCROCIS DIMINUTIVA* Warr. A. M. N. H. (6) xviii. p. 168. Assam.(17) *DICHOCROCIS HÆMACTALIS* Snell. Trans. Ent. Soc. 1890, p. 592. N.E. India; Pulo Laut; Sumbawa.(18) *DICHOCROCIS THARSALEA* Meyr. Trans. Ent. Soc. 1887, p. 225. Australia.(19)†*DICHOCROCIS FESTIVALIS* Swinh. P. Z. S. 1885, p. 872. Bombay.(20) *DICHOCROCIS PUNCTILINEALIS*, n. sp.

♂. Orange; fore tibiæ and tarsi white banded with black; abdomen with black spot before the anal tuft. Fore wing with subbasal black points on costa and inner margin; an obscure curved antemedial line with black points on costa and below median nervure; a prominent black discoidal spot; the indistinct postmedial line with blackish points on it, excurved between veins 6 and 2, then retracted to below angle of cell; traces of a subterminal series of points, one near tornus more prominent. Hind wing with black discoidal spot; the postmedial line excurved to vein 2, then retracted to below cell and with fuscous points on it; traces of subterminal fuscous points more prominent towards tornus: both wings with slight fuscous terminal line.

Hab. Tenimber (*Doherty*). *Exp.* 30 mm. Type in Coll. Rothschild.

(21) *DICHOCROCIS NIGRILINEALIS* Wlk. xxxiv. 1410. India; Ceylon; Burma; Sula; Sumbawa.

†*Haritala tigrina* Moore, Lep. Ceyl. iii. p. 312, pl. 182. f. 5.

Botys demeter Snell. Trans. Ent. Soc. 1890, p. 586.

†*Notarcha compsogramma* Meyr. Trans. Ent. Soc. 1894, p. 461.

(22)†*DICHOCROCIS DEFINITA* Butl. Ill. Het. vii. p. 97, pl. 133. f. 9. Himalayas; Assam.(23)†*DICHOCROCIS PLUTUSALIS* Wlk. xvii. 478.

N.E. India; Andamans.

†*Haritala discinotalis* Moore, P. Z. S. 1877, p. 617.

- (24) *DICHOCROCIS PACTOLICA* Butl. A. M. N. H. (5), xx p. 122
(1887). Solomons.
- (25) *DICHOCROCIS RECURRENS* Moore, Lep. Atk. p. 215, pl. 7. f. 11.
Sikkim.
- (26) *DICHOCROCIS PYRRHALIS* Wlk. xvii. 483. S. India; Ceylon;
Borneo; Pulo Laut.
†*Haritala angulifascia* Hmps. Ill. Het. viii. p. 136, pl. 155.
f. 10.
- (27) *DICHOCROCIS PLENISTIGMALIS* Warr. A. M. N. H. (6) xvi.
p. 477. Assam.
- (28) *DICHOCROCIS RIGIDALIS* Snell. Trans. Ent. Soc. 1890, p. 631.
N.E. India; Burma; Pulo Laut.
†*Ravanao strigulosa* Swinh. A. M. N. H. (6) xiv. p. 201.
- (29) †*DICHOCROCIS ZEBRALIS* Moore, P. Z. S. 1867, p. 91, pl. 7.
f. 12. N.E. India.
- (30) †*DICHOCROCIS FUSCOALBALIS*, n. sp.
♂. Head, thorax, and abdomen whitish variegated with
fuscous; abdomen with lateral black bands on two subterminal
segments and lateral streaks on terminal segment. Fore wing
whitish, with oblique black subbasal line, then a fuscous band,
followed by antemedial line; medial area fuscous below the cell;
a black annulus in cell and discoidal reniform spot; the post-
medial line incurved and expanding into a spot beyond cell,
acutely angled on vein 2, then retracted to below end of cell and
excurved again; the whole outer area fuscous, leaving a white
band beyond the postmedial line; a black marginal line. Hind
wing fuscous, with black discocellular spot; a postmedial black
line defined by white on outer side, incurved and expanding
into a spot beyond cell, angled on vein 2, then retracted to below
angle of cell and terminating at anal angle; a marginal black line
defined by white on inner side.
Hab. Sierra Leone (*Clements*). *Exp.* 26 mm. Types in B.M.
and Coll. Schaus.
- (31) *DICHOCROCIS RENIDATA* Fabr. Mant. Ins. ii. p. 215.
Japan; N.E. India; Ceylon;
Botys nilusalis Wlk. xviii. 685. Pulo Laut; Borneo.
† „ *chlorophanta* Butl. Ill. Het. ii. p. 58, pl. 39. f. 8.
†*Hedylepta straminea* Moore, Lep. Ceyl. iii. p. 278, pl. 180.
f. 5.
†*Gadessa albifrons* Moore, Lep. Ceyl. iii. p. 279, pl. 180. f. 6.
„ *subalbalis* Warr. A. M. N. H. (6) xvii. p. 103.
- (32) *DICHOCROCIS MEGILLALIS* Wlk. xviii. 700.
N.E. India; Borneo.
Botys sordidalis Snell. Trans. Ent. Soc. 1890, p. 589 (var.).
Gadessa characteristica Warr. A. M. N. H. (6) xvii. p. 103.

(33) *DICHOCROCIS SPOLIATALIS* Led. Wien. Ent. Mon. 1863,
p. 375, pl. 11. f. 8. Brazil.

(34)†*DICHOCROCIS STRIGIMARGINALIS*, n. sp.
Asopia sernalis var., Wlk. xvii. 366 (*nec* Guen.).

Golden yellow; palpi with the extremity of 1st and 2nd joints and maxillary palpi black, fore tibiæ and tarsi banded with black; abdomen with dorsal black band near base and black and white bands towards extremity. Fore wing with black subbasal spots on costa and inner margin; an antemedial fulvous line arising from a black spot on costa; a discocellular lunule with yellow centre; a postmedial line arising from a black spot on costa, excurved to vein 6, then crenulate to vein 2, along which it is retracted to lower angle of cell, then sinuous to inner margin; a series of black strigæ just inside the margin; cilia black. Hind wing with postmedial line incurved from costa to vein 5, minutely crenulate to vein 2, along which it is retracted to angle of cell, then oblique; a black line just inside the margin; cilia black.

Hab. Amazons. *Exp.* 24 mm.

(35) *DICHOCROCIS CREDULALIS* Snell. Trans. Ent. Soc. 1890,
p. 590. N.E. India.

Pleonectusa planalis Swinh. A. M. N. H. (6) xix. p. 208.

(36)†*DICHOCROCIS AURITINCTA* Butl. Trans. Ent. Soc. 1886, p. 431.
Tenimber; Australia.

Rehimena pallidalis Warr. A. M. N. H. (6) xvii. p. 134.

(37)**DICHOCROCIS EUBULEALIS* Wlk, xviii. 595. Brazil.

Auctorum.

Botrys infundibulalis Snell. Midd.-Sum., Lep. p. 64.

Sumatra; Australia.

Conogethes umbrosa Meyr. P. Linn. Soc. N.S.W. (2) i. p. 256.

New Guinea.

„ *nubifera* Lucas, P. Linn. Soc. N.S.W. (2) vii.
p. 264. Australia.

Genus 60. *NACOLEIA*.

Nacoleia Wlk. xix. 934 (1859).

Lamprosema Hübn. Verz. p. 361 (1827), non descr.

Isopteryx Guen. Delt. & Pyr. p. 227 (1854), preocc.

Hedylepta Led. Wien. Ent. Mon. 1863, p. 409.

Blepharomastix Led. Wien. Ent. Mon. 1863, p. 422.

Pelecyntis Meyr. Trans. Ent. Soc. 1884, p. 316.

Semioceros Meyr. Trans. Ent. Soc. 1884, p. 318.

Pterygisus Butl. Trans. Ent. Soc. 1886, p. 429.

Thysanodesma Butl. Ill. Het. vii. p. 96 (1889).

Aplomastix Warr. A. M. N. H. (6) vi. p. 478 (1890).

Loxocreon Warr. A. M. N. H. (6) ix. p. 432 (1892).

Metasciodes Meyr. Trans. Ent. Soc. 1894, p. 8.

Tylostega Meyr. Trans. Ent. Soc. 1894, p. 457.

Merotoma Meyr. Trans. Ent. Soc. 1894, p. 460.

Macrospectrodes Warr. A. M. N. H. (6) xvii. p. 94 (1896).

Idiusia Warr. A. M. N. H. (6) xvii. p. 98.

Preneopogon Warr. A. M. N. H. (6) xvii. p. 146.

Orthocona Warr. A. M. N. H. (6) xviii. p. 215.

Palpi upturned, reaching vertex of head, the 2nd joint broadly scaled in front, the 3rd with a small triangular tuft in front; maxillary palpi usually slightly dilated with scales; frons rounded; antennæ of male ciliated; tibiæ with the outer spurs usually half the length of inner. Fore wing with veins 3, 4, 5 from angle of cell; 7 straight and well separated from 8, 9, to which 10 is approximated. Hind wing with vein 3 from angle of cell; 4, 5 approximated for a short distance; 6, 7 from upper angle, 7 anastomosing with 8.

Fig. 60.

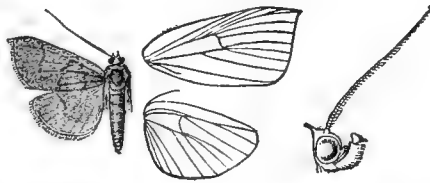

Nacoleia pæonialis, ♂. †. (From Moths Ind. vol. iv.)

SECT. I. (*Nacoleia*). Antennæ of male with the shaft thickened at middle by a more or less developed tuft of scales above; mid tibiæ clothed with rough hair.

A. Tibiæ of male normal.

(1) *NACOLEIA SUBULALIS* Guen. Delt. & Pyr. p. 221. Jamaica;
Surinam; Brazil.

Leucinodes pretiosalis Möschl. Verh. zool.-bot. Ges. Wien, xxxi.
p. 431, pl. 18. f. 38.

(2)†*NACOLEIA ALLOCOSMA* Meyr. Trans. Ent. Soc. 1886, p. 242.

Fiji.

(3)†*NACOLEIA COMMIXTA* Butl. A. M. N. H. (5) iv. p. 453 (1879);
Hmpsn. Ill. Het. ix. pl. 173. f. 24. Japan; India;
Ceylon.

† „ *costisignalis* Moore Lep. Ceyl. iii. p. 273.

Type. (4) *NACOLEIA RHEOALIS* Wlk. xix. 933. Australia.

† „ *murcusalis* Wlk. xix. 935.

†*Botys hypsidesalis* Wlk. xix. 1006.

†*Samea irruptalis* Wlk. xxxiv. 1303.

†*Isopteryx sordidalis* Wlk. xxxiv. 1317.

(5)†*NACOLEIA PARASEPHIS* Meyr. Trans. Ent. Soc. 1887, p. 221.

Australia.

(6)†*NACOLEIA AMPHICEDALIS* Wlk. xvii. 363.

Australia.

†*Isopteryx bilunatalis* Wlk. xxxiv. 1316.

(7) *NACOLEIA OBLIQUALIS*, n. sp.

Head and thorax pale brown; palpi, frons, collar, and metathorax black; abdomen dirty white, with two obscure medial fuscous dorsal bands; wings yellowish white. Fore wing with diffused fuscous shade from termen below apex to base of inner margin; an indistinct dark sinuous antemedial line; an annulus in cell and discocellular spot with pale lunule on it; a semicircular black mark on costa beyond middle and two towards apex. Hind wing with black discoidal point: both wings with an oblique postmedial line excurved between veins 5 and 2; the terminal area fuscous from just beyond the postmedial line; some dark points on termen.

Hab. Cedar Bay, Cooktown, Queensland (*Meek*). *Exp.* 20 mm. Types in Coll. Rothschild and B.M.

(8) *NACOLEIA MESOCHLORA* Meyr. Trans. Ent. Soc. 1884, p. 313.
Australia.

†*Endotricha annuligera* Butl. Trans. Ent. Soc. 1886, p. 427.

(9)†*NACOLEIA TRICROSSA* Meyr. Trans. Ent. Soc. 1886, p. 243.
New Guinea.

(10) *NACOLEIA MARIONALIS* Wlk. xix. 930. N.W. Himalayas;
†*Danaga biformis* Butl. Ill. Het. vii. p. 94, Sikhim; Burma;
pl. 135. ff. 2, 3. Borneo.

(11)†*NACOLEIA PRÆTERITALIS* Wlk. Cat. xvii. 372.
India; Ceylon; Burma.

(12) *NACOLEIA CYANEALIS* Wlk. xvii. 405. Japan; India;
Metasia zanclogramma Meyr. Trans. Ent. Soc. 1894, p. 8. Ceylon; Burma;
Borneo.

(13)†*NACOLEIA TIASALIS* Wlk. xix. 994; Hmpsn. Ill. Het. ix. pl. 173.
f. 20. Ceylon; Australia.
†*Asopia microchrysalis* Wlk. xxxiv. 1306.

B. Fore tibiæ of male with dense curved scales.

(14)**NACOLEIA CHLORURA* Meyr. Trans. Ent. Soc. 1887, p. 222.
Australia.

C. Hind tibiæ of male fringed with long hair from medial spurs to extremity, the 1st two tarsal joints fringed with long hair; claspers and genital tufts very large.

(15) *NACOLEIA HOLOPHÆA*, n. sp.

♂. Fuscous brown; palpi at base, pectus, and ventral surface of abdomen whitish. Fore wing with indistinct sinuous antemedial dark line; a prominent black discoidal spot: both wings with the postmedial line sinuous, bent outwards and minutely dentate between veins 5 and 2, then retracted to lower angle of cell.

Hab. Cooktown, Queensland (*Meek*). *Exp.* 24 mm. Type in Coll. Rothschild.

SECT. II. Antennæ of male with a bifid tuft of scales from basal joint.

(16)†*NACOLEIA ZOILUSALIS* Wlk. xviii. 603.

W. Indies; Honduras; Brazil.

(17)†*NACOLEIA IARCHASALIS* Wlk. xix. 983 (♀). St. Domingo.

†*Botys differalis* Wlk. xxxiv. 1228.

SECT. III. Antennæ of male with the base of shaft excised, the basal joint tufted with hair.

(18)†*NACOLEIA MELLEALIS* Swinh. Trans. Ent. Soc. 1890, p. 282.

Bengal; Burma; Malay Pen.

SECT. IV. Antennæ of male normal.

A. (*Preneopogon*). Palpi of male fringed below with long hair enclosed between the 1st and 2nd joints, the 2nd and 3rd joints being doubled back below; maxillary palpi greatly dilated with scales; fore femora with a tuft of long hair from base; fore and mid femora and tibiæ clothed with rough hair; a large expansible anal tuft.

(19) *NACOLEIA BARBATA* Warr. A. M. N. H. (6) xvii. p. 146.

Assam.

B. Palpi of male normal.

a. Fore wing of male with postmedial lobe on costa.

(20) *NACOLEIA PRAGONIALIS*, n. sp. (Plate XLIX. fig. 8.)

♂. Orange fulvous; head and thorax suffused with fuscous. Fore wing with the costal and terminal areas tinged with fuscous; a curved black antemedial line; a speck in cell and double discoidal lunule; the postmedial line obliquely curved below costa, angled inwards on vein 5, at vein 2 retracted to lower angle of cell, then slightly angled on vein 1; three black spots on costa towards apex. Hind wing with black discoidal point; the postmedial line strongly bent outwards between veins 5 and 2, then retracted to below end of cell: both wings with black line and line through the cilia leaving orange points at their base.

Hab. Humboldt Bay, N. Guinea (*Doherty*). *Exp.* 14 mm. Type in Coll. Rothschild and B.M.

(21)**NACOLEIA CIRROSALIS* Feld. Reise Nov. pl. 135. f. 37. Brazil.

b. (*Tylostega*). Fore wing of male with a tuft of large scales in cell above and a very large fan of scales in cell below.

(22) *NACOLEIA VALVATA* Warr. A. M. N. H. (6) xvii. p. 104.

Assam.

(23)†*NACOLEIA PHOTIAS* Meyr. Trans. Ent. Soc. 1894, p. 458.

Pulo Laut; Borneo.

- (24)†*NACOLEIA MESODORA* Meyr. Trans. Ent. Soc. 1894, p. 458.
Pulo Laut
- (25)†*NACOLEIA CHRYSANTHES* Meyr. Trans. Ent. Soc. 1894, p. 458.
Pulo Laut.
- c.* (*Macrospectrodes*). Hind wing of male with a large hyaline vesicle on inner area.
- (26) *NACOLEIA SUBARGENTALIS* Snell. Trans. Ent. Soc. 1890, p. 579
Sikhim.
- d.* Hind wing of male with the inner area very short, the tornus lobed and fringed with thick hair; abdomen with ventral valve and tuft at base.
- (27)†*NACOLEIA DOBSALIS* Wlk. xviii. 616. Colombia; Brazil.
Botys codrusalis Wlk. xviii. 616.
,, *cenippealis* Wlk. xviii. 619.
- e.* Wings of male normal.
- a*¹. (*Merotoma*). Hind tibiæ of male very short, with a tuft of hair above; the outer medial spur absent, the inner greatly dilated.
- (28)†*NACOLEIA DAIRALIS* Wlk. xviii. 698. Borneo; Pulo Laut;
Celebes.
- b*¹. Hind tarsi of male with the 1st three joints tufted with curled hair on inner side; abdomen with the terminal segment long, with lateral tufts from its base and large genital tufts.
- (29) *NACOLEIA LUNULALIS* Hübn. Zutr. ii. 21. 152, ff. 303-4.
Venezuela; Surinam.
- c*¹. Mid tibiæ of male with groove containing a tuft of long hair.
- (30)†*NACOLEIA PERDENTALIS*, n. sp.
- Head and thorax brown mixed with olive-yellow; abdomen olive-yellow banded with fuscous above. Fore wing fuscous, some olive-yellow on basal area; an irregularly waved dark ante-medial line defined by yellow on inner side; prominent round black orbicular and reniform stigmata on a yellowish ground; a very highly dentate postmedial line bent outwards between veins 5 and 2 and defined by yellow on outer side. Hind wing with the basal area yellowish, with round fuscous spot in cell; a very highly dentate medial line defined by olive-yellow on outer side and bent outwards between veins 5 and 2; terminal area fuscous: cilia of both wings chequered yellow and fuscous. Underside of fore wing with the ground-colour of cell orange.
- Hab.* Amboina; Bourou (*Doherty*); Fergusson I., N. Guinea (*Meek*). *Exp.* 28-30 mm.

*d*¹. Legs of male normal.

*a*². (*Hedylepta*). Patagia of male with a tuft of hair reaching well beyond metathorax.

*a*³. Abdomen of male with ventral valve and tuft at base, the terminal segment very long with lateral and genital tufts.

(31)†*NACOLEIA PELEALIS* Wlk. xvii. 338. Haiti; Venezuela.

*b*³. Abdomen of male with large dorsal and slight ventral tufts at base.

(32)†*NACOLEIA CANACEALIS* Wlk. xvii. 343. Venezuela; Brazil.

*c*³. Abdomen of male normal.

(32 *a*)**NACOLEIA AUROINCTALIS*, n. sp.

♂. Golden-brown mixed with fuscous hairs; palpi at base, pectus, legs, and ventral surface of abdomen whitish. Fore wing with the mixture of black hairs prominent, becoming a diffused patch on basal inner area. Hind wing strongly suffused with black hairs, becoming a diffused patch on disk; both wings with yellow line at base of cilia.

Hab. Niger, Warri (*Roth*). *Exp.* 22 mm. Type in Coll. Rothschild.

(33)†*NACOLEIA LADONALIS* Wlk. xviii. 637. W. Africa.

(34) *NACOLEIA CONFUSALIS* Warr. A. M. N. H. (6) xvii. p. 98. Japan.

(35) *NACOLEIA TRISTRIALIS* Brem. Lep. Ost-Sib. p. 68, pl. 6. f. 7. Amur; N.E. India; Burma.

Hedylepta confusalis Warr. A. M. N. H. (6) xvii. p. 98.

„ *ochrifuscalis* Warr. A. M. N. H. (6) xvii. p. 98.

(36)†*NACOLEIA PÆONALIS* Wlk. xviii. 639. W. Africa; India;

Botys halmusalis Wlk. xviii. 693. Ceylon; Burma;

† „ *bianoralis* Wlk. xix. 1001. Borneo; Java;

„ *minoralis* Wlk. xxxiv. 1420. Flores; Sula.

† „ *decisalis* Wlk. xxxiv. 1351.

† „ *præteritalis* Wlk. xxxiv. 1405; Hmps. Ill. Het. ix. pl. 173. f. 3.

†*Asopia misera* Butl. Ill. Het. iii. p. 74, pl. 59. f. 5.

Botys korndorfferi Snell. Midd.-Sum., iv. Lep. p. 62.

†*Acharana similis* Moore, Lep. Ceyl. iii. p. 286, pl. 180. f. 12.

†*Charema fuscipennis* Swinh. A. M. N. H. (6) xiv. p. 202.

Pachyzancla granulata Warr. A. M. N. H. (6) xviii. p. 174.

(37)†*NACOLEIA NIPHEALIS* Wlk. xviii. 638. W. Africa; N.E.

†*Botys epastalis* Swinh. P. Z. S. 1885, p. 874, & W. India. pl. 57. f. 13.

(38)†*NACOLEIA LEUCOSTREPTA* Meyr. Trans. Ent. Soc. 1886, p. 254. Fiji.

(39)†*NACOLEIA VITTIFFERA*, n. sp.

Black; palpi white below; coxæ and tarsi white; abdomen with prominent white rings on two subterminal segments and slight segmental lines on the others, a ventral white fascia on basal segments. Fore wing with curved black antemedial line; a discocellular spot; the postmedial line black, with wedge-shaped white mark on its outer edge from costa to vein 6, nearly straight to vein 3, then retracted to angle of cell; cilia white, fuscous at middle and tornus. Hind wing with discoidal point; the postmedial line nearly straight from costa to vein 2, then retracted to angle of cell; cilia white, fuscous at tornus.

Hab. Amboina; Fergusson I., N. Guinea (*Meek*). *Exp.* 22 mm.

(40)†*NACOLEIA BLACKBURNI* Butl. E. M. M. xiv. p. 48.

Sandwich I.

(41)†*NACOLEIA ACCEPTA* Butl. E. M. M. xiv. p. 49.

Sandwich I.

(42) *NACOLEIA CONTINENTALIS* Wllgrn. Eug. Resa, p. 381.

Sandwich I.

(43)†*NACOLEIA DEMARATALIS* Wlk. xix. 1009.

Sandwich I.

(44)†*NACOLEIA LOCALIS* Butl. E. M. M. xv. p. 271.

Sandwich I.

(45)**NACOLEIA STIGMATILIS* Warr. A. M. N. H. (6) xvii. p. 101.

Assam.

(46) *NACOLEIA INDICATA* Fabr. Syst. Ent. p. 640.

Neotropical,

„ *vulgalis* Guen. Delt. & Pyr. p. 202,
pl. 6. f. 8.

Ethiopian, &
Oriental regions.

Botys sabalis Wlk. xviii. 631.

† „ *meliusalis* Wlk. xviii. 703.

† „ *connexalis* Wlk. xxxiv. 1394.

„ *reductalis* Wlk. xxxiv. 1412.

(47) *NACOLEIA DIEMENALIS* Guen. Delt. & Pyr. p. 203. S. Africa;

Pyrausta absistalis Wlk. xvii. 311.

Oriental region;

†*Asopia lydiialis* Wlk. xvii. 374.

Fiji.

Botys ustalis Led. Wien. Ent. Mon. 1863, p. 375, pl. x. f. 14.

†*Pyralis incertalis* Wlk. xxxiv. 1247.

Hedylepta pyraustalis Snell. Midd.-Sum., iv. Lep. p. 70.

(48)**NACOLEIA AURANTIFASCIALIS* Hmps. (♀) Moths Ind. iv.
p. 314. Manipur.(49)†*NACOLEIA FUSCIFIMBRIALIS* Hmps. Moths Ind. iv. p. 315.

Ceylon.

(50)†*NACOLEIA CUPREALIS* Moore, P. Z. S. 1877, p. 616, pl. 60.
f. 13 (♀). Assam; Burma; Andamans.

Platamonia binotalis Warr. A. M. N. H. (6) xviii. p. 177.

(51)†*NACOLEIA SALBIALIS*, n. sp.

♂. Fuscous; palpi white below; abdomen with white patch on anal tuft; pectus and ventral surface of abdomen whitish. Fore

wing with fuscous antemedial line obtusely angled on median nervure and defined by whitish on inner side; a black speck in cell and discoidal lunule; the postmedial line bent outwards between veins 5 and 3, then retracted to below angle of cell and sinuous, outlined with whitish and becoming a prominent spot on costa; cilia chequered whitish and fuscous. Hind wing with discoidal black spot; the postmedial line outlined with whitish, bent outwards between veins 5 and 2, then retracted and ending at anal angle; a black terminal line and line through cilia which are white.

Hab. Orizaba, Mexico. *Exp.* 26 mm. Types in B.M. and Coll. Schaus.

(52)†*NACOLEIA LUNIDISCALIS*, n. sp.

♀. Fuscous brown with a rufous tinge; palpi white below; abdomen with a black band on penultimate segment. Fore wing with nearly straight antemedial black line arising from a spot on costa; a fuscous-edged white speck in cell and another below it; a prominent white discocellular lunule connected with a spot beyond lower angle of cell, and outlined by the black postmedial line arising from a spot on costa, and at vein 2 retracted to the origin of vein 2. Hind wing with discocellular spot; a postmedial line sinuous from costa to vein 2, where it is retracted to angle of cell and ends at anal angle: both wings with marginal dark line and line through base of cilia.

Hab. Aburi, W. Africa. *Exp.* 24 mm.

(53)†*NACOLEIA OLIVIA* Butl. P. Z. S. 1878, p. 434 (♀). Jamaica.

♂. (*Blepharomastyx*). Patagia of male not extending beyond metathorax.

(54)†*NACOLEIA SEMICOSTALIS*, n. sp. (Plate XLIX. fig. 22.)

♂. Head, thorax, and abdomen black with a bluish tinge; palpi white below; anal tuft ochreous. Fore wing golden yellow, with a broad black fascia from base of inner margin along costa to middle, then running as an oblique band to outer angle; apical area black and a black marginal line. Hind wing golden yellow, with black marginal band broadest at apex and anal angle.

Hab. São Paulo (*Jones*). *Exp.* 22 mm.

(55) *NACOLEIA INSOLITALIS* Wlk. Trans. Ent. Soc. (3) i. p. 125.

Nicobars; Borneo.

(56) *NACOLEIA BENEPICALIS* Warr. A. M. N. H. (6) xvii. p. 99.

Assam.

(57)†*NACOLEIA KINGDONI* Butl. A. M. N. H. (5) iv. p. 246 (1879).

Madagascar.

(58) *NACOLEIA XANTHIALIS* Guen. Delt. & Pyr. p. 343.

W. Indies; S. America.

†*Botys superbalis* Wlk. xxxiv. 1397.

„ *incalis* Snell. Tijds. v. Ent. xviii. p. 202, pl. 11. f. 13.

(59)†*NACOLEIA JUNCTITHYRALIS*, n. sp. (Plate XLIX. fig. 9.)

Purplish fuscous; head blackish; palpi white below; abdomen with white band at base; thorax and abdomen white below, fore tibiæ with black band. Fore wing with hyaline point below origin of vein 2 and another in end of cell; a patch beyond the cell expanding outwards and minutely dentate between veins 5 and 2. Hind wing with a large hyaline patch in and below the cell conjoined to a large patch beyond the cell which has its outer edge angled on vein 5, then minutely dentate; both wings with the cilia white towards tornus.

Hab. Fergusson I., N. Guinea (*Meek*). *Exp.* 26 mm.

(60)†*NACOLEIA RUBRALIS*, n. sp.

♂. Ferruginous red; anal tuft ochreous. Fore wing with ill-defined yellower patches on medial area and on disk; an indistinct sinuous black antemedial line; the yellow medial patches defined on outer side by a waved black line; a minutely dentate post-medial line retracted at vein 2 to below angle of cell. Hind wing with black discocellular speck; a very obscure postmedial line bent outwards and highly dentate between veins 5 and 2.

Hab. Madagascar. *Exp.* 32 mm.

(61)†*NACOLEIA PERFENESTRATA* Butl. A. M. N. H. (5) x. p. 237
(1882). New Britain.

(62)†*NACOLEIA ALBIFLAVIALIS* Hmps. J. Bomb. N. H. Soc. ined.
Ceylon; Celebes; Sumbawa.

(63) *NACOLEIA EBULEALIS* Guen. Delt. & Pyr. p. 196. U.S.A.;
Honduras; W. Indies.

(64)†*NACOLEIA PERSUALIS*, n. n. Brazil.
Volibia major Warr. Trans. Ent. Soc. 1889, p. 293 (preocc.).

(65) *NACOLEIA APYGALIS* Guen. Delt. & Pyr. p. 229. Mexico;
W. Indies; Centr. Amer.; Colombia.
Pterygisis appialis Druce, Biol. Centr.-Am., Het. ii. p. 238,
pl. 62. f. 7.

(66) *NACOLEIA APLICALIS* Guen. Delt. & Pyr. p. 229. U.S.A.
Isopteryx xeniolalis Hulst, Tr. Am. Ent. Soc. xiii. p. 159.

(67)†*NACOLEIA SCITALIS* Swinh. P. Z. S. 1885, p. 869. Bombay.

(68)**NACOLEIA VESTALIALIS* Snell. Tijd. v. Ent. 1875, p. 245, pl. 14.
f. 1. Colombia; Peru.

(69)†*NACOLEIA PALLIDIPENNIS* Warr. Trans. Ent. Soc. 1889, p. 285.
Brazil.

(70) *NACOLEIA BATRACHALIS* Guen. Delt. & Pyr. p. 243. Brazil.

(71)**NACOLEIA CYLONALIS* Druce, Biol. Centr.-Am., Het. ii. p. 258,
pl. 62. f. 25. Guatemala.

- (72) *NACOLEIA COLUBRALIS* Guen. Delt. & Pyr. p. 242. Brazil.
Botys ineffectalis Wlk. xxxiv. 1390.
 † „ *electralis* Wlk. xviii. 600.
 „ *melitealis* Wlk. xviii. 602.
- (73)† *NACOLEIA CENEUSALIS* Wlk. xviii. 604. Honduras.
- (74) *NACOLEIA LACERTALIS* Guen. Delt. & Pyr. p. 244. Brazil.
- (75) *NACOLEIA RANALIS* Guen. Delt. & Pyr. p. 243. U.S.A.;
 † *Asopia archasialis* Wlk. xvii. 365. Mexico; Centr. Am.
 † *Botys ofellusalis* Wlk. xviii. 732.
 † „ *olliusalis* Wlk. xix. 982.
 † „ *strictalis* Wlk. xxxiv. 1392.
 † „ *gracilis* Grote & Rob. Tr. Am. Ent. Soc. i. p. 25, pl. 2.
 f. 15.
Blepharomastix datialis Druce, Biol. Centr.-Am., Het. ii.
 p. 269, pl. 63. f. 3.
- (76) *NACOLEIA COATEPECENSIS* Druce, Biol. Centr.-Am., Het. ii.
 p. 270, pl. 63. f. 8. Mexico; Brazil.
- (77) *NACOLEIA VILIALIS* Guen. Delt. & Pyr. p. 244. Mexico;
 Centr.-Am.; Brazil.
Blepharomastix pulverulalis Druce, Biol. Centr.-Am., Het. ii.
 p. 269, pl. 63. f. 2.
- (78) *NACOLEIA TAMPIUSALIS* Wlk. xviii. 704. India; Borneo.
 † *Botys ilusalis* Wlk. xviii. 705.
 „ *dascyllusalis* Wlk. xix. 1003.
 † *Aplomastix mimula* Hmps. Ill. Het. viii. p. 137, pl. 155. f. 23.
Metasia lilliputalis Snell. Tijd. v. Ent. 1880, p. 229, & 1884,
 pl. 3. f. 8.
 † *Metasiodes calliophis* Meyr. Trans. Ent. Soc. 1894, p. 466.
- (79)† *NACOLEIA LEONINA* Butl. Trans. Ent. Soc. 1886, p. 425.
 Australia.
- (80)† *NACOLEIA MONINALIS* Wlk. xvii. 373. Borneo.
- (81)* *NACOLEIA HELIAULA* Meyr. Trans. Ent. Soc. 1894, p. 8 (♀).
 Burma.
- (82) *NACOLEIA FUSALIS* Warr. A. M. N. H. (6) xvii. p. 142 (♀).
 Assam.
- (83) *NACOLEIA CÆAXALIS* Wlk. xviii. 718. Assam; Borneo.
Thysanodesma discalis Warr. A. M. N. H. (6) xvii. p. 140.
- (84) *NACOLEIA PUNCTICOSTALIS*, n. sp.

Fulvous yellow; palpi black at extremities. Fore wing with the basal half of costa tinged with fuscous; a curved antemedial dark line with annulus on its outer edge in cell; a discoidal reniform spot with yellow centre; a postmedial line angled inwards on vein 5, at vein 2 retracted to lower angle of cell, then angled outwards on vein 1; three black points on costa towards apex and

a series of marginal points. Hind wing with antemedial line; the postmedial line bent outwards at vein 5, then sinuous to tornus; a series of marginal black points.

Hab. Batchian (*Doherty*). *Exp.* 14–18 mm. Types in Coll. Rothschild and B.M.

(85) *NACOLEIA RUFITERMINALIS*, n. sp.

Yellow; head, thorax, and abdomen suffused with rufous. Fore wing with the costal and terminal areas suffused with rufous and leaden grey; a rufous antemedial line; an annulus in cell and discoidal reniform spot with yellow centre; the postmedial line angled inwards on vein 5 and at vein 2 retracted to the cell; two yellow points on costa towards apex. Hind wing with rufous discoidal point; the postmedial line bent outwards between veins 5 and 2, then retracted to below cell, almost the whole area beyond it rufous and leaden grey.

Hab. Batchian; Halmaheira. *Exp.* 14 mm. Types in Coll. Rothschild and B.M.

(86) *NACOLEIA MAGNALIS* Guen. Delt. & Pyr. p. 230, pl. 9. f. 6.

†*Samea medealis* Wlk. xvii. 353. U.S.A.; W. Indies.

†*Botys belusalis* Wlk. xviii. 582.

†*Asopia curtalis* Wlk. xxxiv. 1305.

(87)**NACOLEIA RHEALIS* Druce, Biol. Centr.-Am., Het. ii. p. 239, pl. 62. f. 9. Mexico.

(88) *NACOLEIA STENTIALIS* Guen. Delt. & Pyr. p. 231. U.S.A.;

†*Samea acestecalis* Wlk. xvii. 352. Mexico; Honduras;

†*Asopia phœrusalis* Wlk. xvii. 368. Brazil.

Blepharomastix sagralis Druce, Biol. Centr.-Am., Het. ii. p. 270 pl. 63. f. 7.

(89)†*NACOLEIA MAJOR* Butl. Ill. Het. vii. p. 96, pl. 135. f. 5. N.W. Himalayas.

(90)†*NACOLEIA OSSEA* Butl. Ill. Het. vii. p. 96, pl. 135. f. 6. N.W. Himalayas.

(91) *NACOLEIA OCTASEMA* Meyr. Trans. Ent. Soc. 1886, p. 259. New Hebrides; Solomons.

(92) *NACOLEIA CHARESALIS* Wlk. xviii. 709. W. India; Ceylon;

†*Botys molusalis* Wlk. xix. 993. Borneo; Sumbawa.

(93) *NACOLEIA PEDICIALIS* Snell. Tijd. v. Ent. xxxviii. p. 49, pl. 6. f. 11. Assam; Java.

Metasciodes apicalis Warr. A. M. N. H. (6) xviii. p. 216.

(94) *NACOLEIA PHALEASALIS* Wlk. xviii. 713. Assam; Borneo.

(95) *NACOLEIA EXIMIALIS* Warr. A. M. N. H. (6) xvii. p. 141. Assam.

(96) *NACOLEIA DIDASALIS* Wlk. xviii. 707. Borneo; Sumbawa.

†*Metasia achromatias* Meyr. Trans. Ent. Soc. 1894, p. 465.

- (97)†*NACOLEIA THOLEROPA* Meyr. Trans. Ent. Soc. 1894, p. 466.
Sumbawa.
- (98) *NACOLEIA PANTHERALIS* Hübn. Geyer, Zutr. 20. 337, ff. 673,
674. Brazil.
- †*Zebronia ledalis* Wlk. xvii. 474.
Ledereria seppalis Snell. Tijd. v. Ent. 1875, p. 258, pl. 14. f. 12.

Auctorum.

- Omiodes monogona* Meyr. Trans. Ent. Soc. 1888, p. 216. Hawaii.
- „ *lodyta* Meyr. Trans. Ent. Soc. 1888, p. 217. Hawaii.
- Botys rubricetalis* Snell. Tijd. v. Ent. xxiii. p. 209, & xxvi.
pl. 7. ff. 4, 4a. Celebes.
- Eclipsiodes marmaropa* Meyr. P. Linn. Soc. NS.W. iv. p. 1111.
Australia.
- Pterygisus calligraphalis* Snell. Tijd. v. Ent. xxxv. p. 175, pl. x.
f. 13. Java.
- Ercta dixialis* Snell. Tijd. v. Ent. xxxviii. p. 149, pl. vi. f. 12.
Java.
- Botys allalis* Guen. Delt. & Pyr. p. 347. Cayenne.
- Mimorista salaconalis* Druce, Biol. Centr.-Am., Het. ii. p. 245,
pl. 62. f. 17. Centr. Am.

Genus 61. GONIORHYNCHUS.

Goniorhynchus Hampsn. Moths Ind. iv. p. 322 (1896).

Palpi upturned, the 2nd joint broadly angled with scales in front, the 3rd short, naked, and blunt; maxillary palpi filiform; frons rounded or prominent; tibiæ with the outer spurs two-thirds length of inner. Fore wing with veins 3, 4, 5 from angle of cell; 7 straight and well separated from 8, 9. Hind wing with the cell short; veins 3, 4, 5 from angle; 6, 7 from upper angle, 7 anastomosing with 8.

Fig. 61.

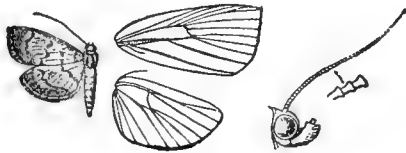

Goniorhynchus plumbeizonalis, ♂. 1. (From Moths Ind. vol. iv.)

SECT. I. Antennæ of male bipectinate, with short fasciculate branches.

A. Antennæ of male with a very large tuft of hair on upper-side of shaft at base.

(1)†*GONIORHYNCHUS* *OBSCURUS*, n. sp.

Fuscous; palpi blackish; antennæ of male with the tuft black. Fore wing with the costal area blackish; the sinuous antemedial

line obtusely angled on median nervure; a speck in cell and discoidal spot; the postmedial line of both wings bent outwards and dentate between veins 5 and 2, then retracted to below angle of cell.

Hab. Amboina (*Doherty*). *Exp.* 20 mm. Types in Coll. Rothschild and B.M.

B. Antennæ of male without tuft of hair at base.

(2) GONIORHYNCHUS PECTINALIS, n. sp.

Fuscous; palpi white at base. Fore wing with dark antemedial line obtusely angled on median nervure; a point in cell and small discoidal lunule; the postmedial line outlined with ochreous, slightly bent outwards and dentate between veins 5 and 2, then retracted to below angle of cell and excurved again. Hind wing with discoidal point; the postmedial line outlined with ochreous, bent outwards and dentate between veins 5 and 2, then retracted to below angle of cell: both wings with fine black marginal line and line through the cilia.

Hab. Padang Rengas, Malacca. *Exp.* 20 mm. Types in Coll. Rothschild and B.M.

SECT. II. Antennæ of male annulated with rings at the joints; fore wing with a fovea covered with hair at base of median nervure.

(3)†GONIORHYNCHUS PLUMBEIZONALIS Hmpsn. Moths Ind. iv.
p. 323. Assam; Burma.

(4) GONIORHYNCHUS FLAVIGUTTALIS Warr. A. M. N. H. (6) xvii.
p. 140. Assam.

SECT. III. Antennæ of male smooth and ciliated; fore wing with no fovea.

A. Frons rounded.

(5)†GONIORHYNCHUS EXEMPLARIS, n. sp.

♀. Yellow; palpi fuscous, white at base. Fore wing with the costal area brown; a waved antemedial brown line; spot in cell and pale-centred reniform discocellular spot; a postmedial wavy line sinuous from costa to vein 5, then bent outwards to vein 2, where it is retracted to angle of cell; a brown marginal band very broad at apex and expanding into a patch at inner angle. Hind wing with discocellular speck; a postmedial line greatly bent outwards between veins 5 and 2 and dentate on those veins; a marginal line expanding into a patch at apex.

Hab. Japan. *Exp.* 26 mm.

(6)†GONIORHYNCHUS BUTYROSA Butl. Ill. Het. iii. p. 73, pl. 59. f. 1.
Japan; China.

Type. (7) GONIORHYNCHUS GRATALIS Led. Wien. Ent. Mon. 1863, p. 473, pl. 11. f. 18. N.E. India; Burma; Java.
Botys minualis Wlk. xxxiv. 1449.

(8)†GONIORHYNCHUS PHILENORALIS Wlk. xviii. 577. Jamaica.
 †*Botys gealis* Wlk. xviii. 578.

B. Frons with rounded prominence.

(9) GONIORHYNCHUS MARASMIALIS, n. sp.

♂. Yellow; palpi black, white at base; frons and mesothorax blackish; abdomen with black spot before extremity and streaks on anal tuft. Fore wing with the costa fuscous; a black spot in cell, with straight line from it to inner margin; a discoidal lunule; the postmedial line almost straight from costa to vein 2, where it is retracted to angle of cell, then straight to inner margin; the terminal area fuscous, narrowing between veins 4 and 2. Hind wing with discoidal spot; the postmedial line slightly bent outwards between veins 5 and 2, then retracted to lower angle of cell; a terminal fuscous band expanding at vein 2.

Hab. Bali; Dili (*Doherty*). *Exp.* 20 mm. Type in Coll. Rothschild.

Auctorum.

Botys chalybealis Snell. Tijd. v. Ent. xxxv. p. 160, pl. x. ff. 5, 6. Java.

Genus 62. ERINOTHUS, nov.

Palpi upturned, the 2nd joint broadly scaled in front, the 3rd short and blunt; maxillary palpi rather long and filiform; frons rounded; antennæ of male with fascicles of cilia, contorted and with a tuft of hair at one-third from base; tibiæ with the outer spurs very long, the inner about half their length. Fore wing of male with the costa folded over above just beyond middle and

Fig. 62.

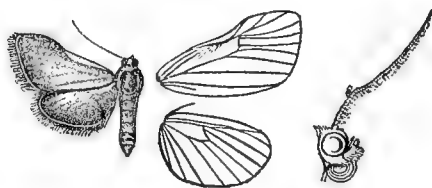

Erinothus lolialis, ♂. $\frac{2}{3}$.

enclosing tufts of hair (the neuration so distorted as to be hardly decipherable in the two not good specimens); vein 2 from near base of cell; 3 from before angle; 4, 5 separate, then approximated for a short distance; 6, 7 approximated for a short distance; 8, 9 stalked, then separating widely; 10, 11 in the costal fold. Hind wing with vein 3 from well before angle of cell; 5 from above

middle of discocellulars ; 6, 7 stalked, 7 anastomosing with 8 for a short distance towards apex.

Type. †ERINOTHUS LOLLIALIS Wlk. xix. 1005.

Borneo.

Genus 63. ACHANTODES.

Achantodes Guen. Noct. ii. p. 386 (1852).

Palpi upturned, the 2nd joint smoothly scaled, the 3rd short and blunt ; maxillary palpi dilated with scales ; frons rounded ; antennæ laminate ; tibiæ with the outer spurs two-thirds length of inner. Fore wing with the costa straight ; the apex produced to a point ; the outer margin excised below apex and much excurved at middle ; vein 3 from before angle of cell ; 4, 5 from angle ; 7 straight ; 10 approximated to 8, 9. Hind wing with the outer margin slightly excised below apex ; vein 3 from angle of cell ; 4, 5 approximated for some distance ; 6, 7 from upper angle, 7 anastomosing with 8.

Fig. 63.

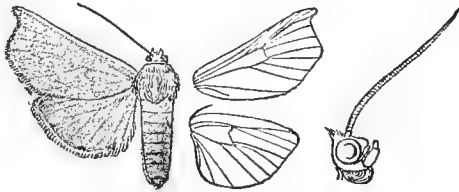

Achantodes cerusicosta, ♂. †.

Type. ACHANTODES CERUSICOSTA Guen. Noct. ii. p. 386.

Venezuela.

Genus 64. PILETOSOMA, nov.

Palpi upturned, the 2nd joint moderately scaled in front, the 3rd short and blunt ; maxillary palpi minute ; frons rounded ; antennæ of male minutely ciliated ; abdomen extremely long, the proximal segments with tufts of hair at sides, the anal tuft long ; tibiæ with the outer spurs about two-thirds length of inner ; wings long and narrow. Fore wing with veins 3, 4, 5 from angle of cell ; 7 curved and approximated to 8, 9, to which 10 also is approximated. Hind wing with veins 3, 4, 5 from angle of cell ; 6, 7 from upper angle, 7 anastomosing with 8.

Fig. 64.

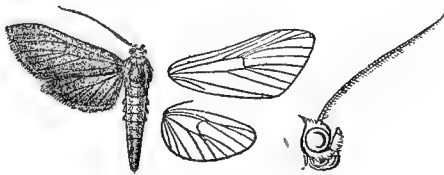

Piletosoma novalis, ♂. †.

Type. (1) PILETOSOMA NOVALIS Wlk. xxxiv. 1399.

Villa Nova, Brazil.

(2) *PILETOSOMA IGNEODORSALIS*, n. sp. (Plate XLIX. fig. 7.)

♂. Cupreous brown; antennæ white at tips; tegulæ and abdomen above fiery red and orange; anal tuft black; fore coxæ, tarsi, and basal half of ventral surface of abdomen yellowish white. Fore wing with hyaline spot at origin of vein 2 and thinly-scaled patches in end of cell and between bases of veins 2 and 7. Hind wing with the basal half hyaline, the veins and a discoidal band fuscous.

Hab. Peru. *Exp.* 32 mm.

Genus 65. *DEBA*.

Deba Wlk. xxxiv. 1494 (1865).

Phycidicera Snell. Midd.-Sum., iv. Lep. (1) 8. p. 71 (1880).

Palpi upturned, the 2nd joint reaching vertex of head and slightly scaled in front, with a tuft of hair from extremity hiding the 3rd joint, which is short and blunt; tegulæ of male with long tufts of hair extending beyond the metathorax; the two basal segments of abdomen with long hair on dorsum; tibiæ with the outer spurs about half the length of inner. Fore wing with the costa arched towards apex; the outer margin obliquely rounded; veins 3, 4, 5 from angle of cell; 7 approximated to 8, 9 for about one-third length; 10 also approximated to 8, 9. Hind wing with vein 3 from angle of cell; 4, 5 approximated for a short distance; 6, 7 from upper angle, 7 anastomosing with 8.

Fig. 65.

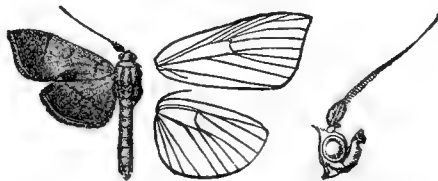

Deba surrectalis, ♂. †. (From Moths Ind. vol. iv.)

SECT. I. Antennæ of male with a small tuft of hair in the form of a vesicle from end of 1st joint, surrounded by a large vesicle formed of nearly conjoined pectinations on the basal part of shaft, which is then serrated for a short distance.

Type. (1)†*DEBA SURRECTALIS* Wlk. xxxiv. 1493. Assam; Ceylon;
Phycidicera salebrialis Snell. Tijd. v. Ent. 1880, Celebes.
p. 228, & 1884, pl. iii. f. 6.

SECT. II. Antennæ of male with a tuft of long hair on base of shaft, then much thickened and fringed with thick scales above; hind wing with a fringe of hair below costa above.

(2) *DEBA ALTHEALIS* Wlk. xvii. 361. Borneo; Sumatra; Celebes.
Botys cydipeialis Wlk. xviii. 6494.
Botys tisiassalis Wlk. xviii. 696.
Phycidicera manicalis Snell. Midd.-Sum., iv. Lep. (1) p. 72.

Genus 66. CERATARCHA.

Ceratarcha Swinh. A. M. N. H. (6) xiv. p. 200 (1894).

Palpi upturned, the 2nd joint broadly angled with scales in front, the 3rd short, blunt, and naked; maxillary palpi filiform; frons rounded; antennæ of male annulate; tibiæ with the outer spurs half the length of inner; mid tibiæ somewhat roughly scaled. Fore wing with the costa arched towards apex; the outer margin excised below apex; veins 3 and 5 from close to angle of cell; 7 and 10 approximated to 8, 9. Hind wing with the outer margin excised below apex; the cell short; veins 4, 5 approximated for a short distance; 6, 7 from upper angle, 7 anastomosing with 8.

Fig. 66.

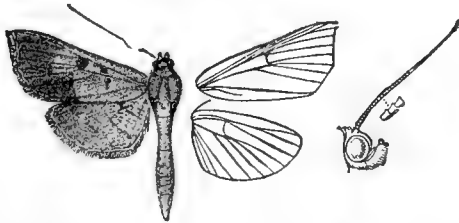

Ceratarcha umbrosa, ♂. †. (From Moths Ind. vol. iv.)

Type. †CERATARCHA UMBROSA Swinh. A. M. N. H. (6) xiv. p. 200.

N.E. India.

Genus 67. BOTYODES.

Botyodes Guen. Delt. & Pyr. p. 321 (1854).

Endocrossis Meyr. Trans. Ent. Soc. 1889, p. 515.

Palpi upturned and reaching vertex of head, the 2nd joint broadly rounded with scales in front, the 3rd short, naked, and blunt; maxillary palpi filiform; frons rounded; antennæ of male minutely ciliated; mid tibiæ fringed with hair on outer side; hind tibiæ with tufts of hair on outer side at base and extremity, the

Fig. 67.

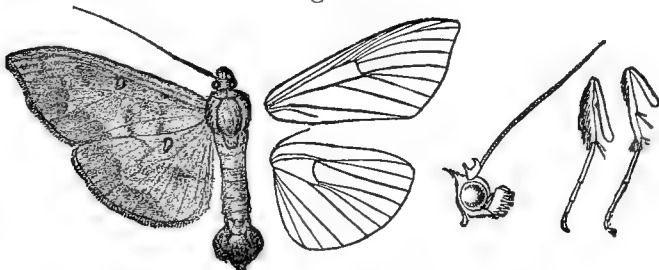

Botyodes asialis, ♂. †. (From Moths Ind. vol. iv.)

outer spurs half the length of inner. Fore wing with veins 3, 4, 5 from angle of cell; 7 closely approximated to 8, 9 for about one-third length; 10 also approximated to 8, 9. Hind wing with the cell short; veins 3, 4, 5 approximated for a short distance; 6, 7 from upper angle or shortly stalked, 7 anastomosing with 8.

SECT. I. (*Botyodes*). Antennæ of male with four teeth on the basal joint enclosing a hollow; mid femora with a small grooved tuft at middle.

- Type.* (1) *BOTYODES ASIALIS* Guen. Delt. & Pyr. p. 321; Moore, Lep. Ceyl. iii. pl. 183. ff. 1, 1 *a* (larva). Beluchistan; India, Ceylon, & Burma; Borneo.
- (2) *BOTYODES PRINCIPALIS* Leech, Entom. xxii. p. 69, pl. 3. f. 9. Japan; Assam.
- † „ *maculalis* Swinh. A. M. N. H. (6) xiv. p. 198.

SECT. II. (*Endocrossis*). Antennæ of male with the basal joint normal; mid femora without the grooved tuft.

A. Hind wing of male with the inner area more or less clothed with long rough hair above and below.

- (3)† *BOTYODES FLAVIBASALIS* Moore, P. Z. S. 1867, p. 96; Feld. Reis. Nov. pl. 135. f. 41. E. Himalayas; Assam; Burma; Sumatra; New Guinea.

B. Hind wing of male without rough hair on inner area.

- (4)* *BOTYODES RUFALIS* Hmps. Moths Ind. iv. p. 327. Burma.
- (5)† *BOTYODES FULVITERMINALIS*, n. sp. (Plate XLIX. fig. 15.)
♂. Orange. Fore wing with indistinct oblique antemedial line; a speck in cell and discoidal reniform spot; the terminal area rufous with sinuous inner edge; an obscure orange subapical patch. Hind wing with discoidal spot; the terminal area rufous, with nearly straight inner edge; cilia of both wings fuscous.
Hab. Kapaur, Humboldt Bay, N. Guinea (*Doherty*). *Exp.* 42 mm.

- (6)† *BOTYODES CALDUSALIS* Wlk. xviii. 650. N.E. India; Burma; Java.

- (7)† *BOTYODES PATULALIS* Wlk. xxxiv. 1405. Himalayas; Assam.

- (8)* *BOTYODES CROCOPTERALIS*, n. sp.

♀. Bright golden yellow; palpi black, white below; throat pure white; thorax and abdomen below black; legs black, tarsi ringed with white; a white spot on fore tibiæ. Fore wing with black antemedial spot on median nervure; a reniform discocellular spot; a postmedial spot below vein 2; the whole apical area black, with rounded inner edge. Hind wing with postmedial black spot above vein 5, with specks above and below it; a spot below vein 2 with speck below it. Underside of fore wing with the basal part of costal area suffused with black.

Hab. Sikhim (*Pilcher*). *Exp.* 40 mm. Type in Coll. Rothschild.

- (9)† *BOTYODES HIRTUSALIS* Wlk. xviii. 642. Natal.

Auctorum.

Botyodes aurealis Leech, Ent. xxii. p. 69, pl. iii. f. 7. Japan.

Genus 68. AUTHÆRETIS.

Authæretis Meyr. Trans. Ent. Soc. 1886, p. 252.

Palpi upturned, the 2nd joint broadly angled with scales in front, the 3rd greatly tufted with hair and reaching far above vertex of head; maxillary palpi dilated with scales; antennæ of male with a projection on basal joint in front and a rounded knob on base of shaft; tibiæ with the outer spurs half the length of inner; abdomen with lateral tufts towards extremity. Fore wing with veins 3, 4, 5 somewhat approximated for a short distance; 7 curved and approximated to 8, 9. Hind wing of male with large tufts of scales below costa and at upper angle of cell below, the area below them clothed with rough fulvous scales; veins 3, 4, 5 from angle of cell; 6, 7 from upper angle, 7 anastomosing with 8.

Fig. 68.

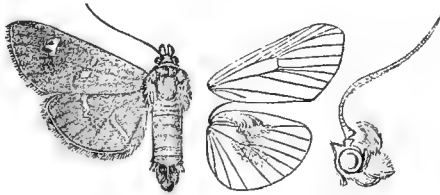

Authæretis eridora, ♂. †.

Type. †AUTHÆRETIS ERIDORA Meyr. Trans. Ent. Soc. 1886, p. 252.

Fiji.

Genus 69. PRORODES.

Prorodes Swinh. A. M. N. H. (6) xiv. p. 205 (1894).

Palpi upturned, the 2nd and 3rd joints conically scaled in female, the 3rd in male broad, hollowed out and enclosing a tuft of hair; maxillary palpi dilated with scales; frons rounded; antennæ of male with the base of shaft excised, then toothed; tibiæ with the outer spurs about half the length of inner. Fore wing with veins 3, 4, 5 from angle of cell; 7 curved and approximated to 8, 9. Hind wing with veins 3, 4, 5 from angle of cell; 6, 7 from upper angle, 7 anastomosing with 8.

Fig. 69.

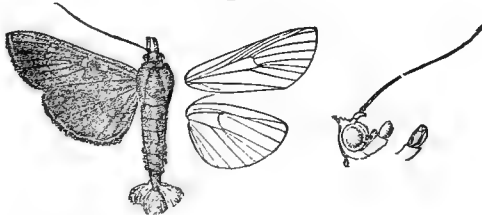

Prorodes mimica, ♂. †. (From Moths Ind. vol. iv.)

Type. †PRORODES MIMICA Swinh. A. M. N. H. (6) xiv. p. 205.

N.E. India; Burma; Malayan subregion;

Notarcha triparalis Warr. A. M. N. H. (6) Queensland.
xvii. p. 102.

Genus 70. *SYLEPTA*.

- Sylepta* Hübn. Verz. p. 356 (1827).
Lypotigris Hübn. Verz. p. 361.
Hyalitis Guen. Delt. & Pyr. p. 289.
Astura Guen. Delt. & Pyr. p. 319.
Asciodes Guen. Delt. & Pyr. p. 374 (1857).
Pantograpta Led. Wien. Ent. Mon. 1863, p. 387.
Sathria Led. Wien. Ent. Mon. 1863, p. 411.
Eritusa Wlk. xxxiv. 1375 (1865).
Herpetogramma Led. Wien. Ent. Mon. 1863, p. 430.
Najia Wlk. xxxiv. 1320.
Notarcha Meyr. Trans. Ent. Soc. 1884, p. 310 (preocc.).
Patania Moore, Lep. Atk. p. 209 (1887).
Pramadea Moore, Lep. Atk. p. 211.
Crocidocnemis Warr. Trans. Ent. Soc. 1889, p. 269.
Pleuroptya Meyr. Trans. Ent. Soc. 1890, p. 443.
Loxoscia Warr. A. M. N. H. (6) vi. p. 476 (1890).
Haritalodes Warr. A. M. N. H. (6) vi. p. 476.
Pardomima Warr. A. M. N. H. (6) vi. p. 477.
Epherema Snell. Tijd. v. Ent. xxxv. p. 170 (1892).
Idiostrophe Warr. A. M. N. H. (6) xvii. p. 133.
Haliotigris Warr. A. M. N. H. (6) xviii. p. 163 (1896).
Polycorys Warr. A. M. N. H. (6) xviii. p. 172.

Palpi upturned and reaching vertex of head, the 2nd joint moderately and evenly scaled in front, the 3rd short, naked, and blunt; maxillary palpi filiform; frons rounded; antennæ of male ciliated; tibiæ smoothly scaled, with the outer spurs about half the length of inner. Fore wing with veins 3, 4, 5 from angle of cell; 7 curved and approximated to 8, 9, to which 10 also is approximated. Hind wing with the cell short; vein 3 from the angle; 4, 5 somewhat approximated for a short distance; 6, 7 from upper angle.

Fig. 70.

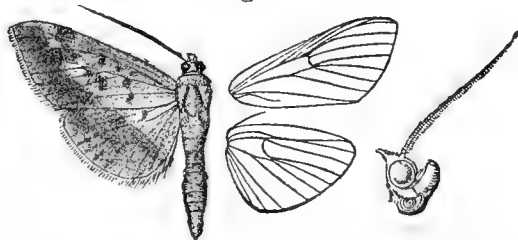
*Sylepta sellalis*, ♂. †. (From Moths Ind. vol. iv.)

SECT. I. Antennæ of male with the shaft excised and contorted at one-third from base, then thickened and bearing an extremely large plumose tuft of black hair extending to beyond middle; mid tibiæ fringed with long hair on outer side.

(1)†*SYLEPTA PLUMIFERA*, n. sp. (Plate XLIX. fig. 10.)

Golden yellow; palpi, antennæ, and shoulders tinged with rufous; fore legs banded with brown. Fore wing with the costal

area rufous; a subbasal black point on inner margin; an antemedial dark rufous line angled below cell, then incurved; a spot in cell and discoidal reniform spot; a dentate postmedial line bent outwards between veins 5 and 2, then retracted to below end of cell; the terminal area rufous from apex to vein 5 and at tornus. Hind wing with discoidal reniform spot; the postmedial line bent outwards and dentate between veins 5 and 2, then retracted to below angle of cell and ending near tornus; the apical area and some terminal lunules rufous: both wings with series of dark points on the cilia.

Hab. Amboina (*Doherty*); Fergusson I., N. Guinea (*Meek*).
Exp. 40 mm.

SECT. II. (*Asciodes*). Antennæ of male contorted and with a large tuft of hair at about one-third from base; fore tibiæ tufted with hair.

(2) SYLEPTA GORDIALIS Guen. Delt. p. 374, pl. 5. f. 10.
St. Domingo; S. America.

†*Scoparia quietalis* Wlk. xix. 825.

Desmia confusalis Hulst, Tr. Am. Ent. Soc. xiii. p. 158.

(3) SYLEPTA SCOPULALIS Guen. Delt. & Pyr. p. 375. Brazil; Peru.
Ceratoclasia verecundalis Berg, Bol. Ac. Nac. Cord. i. p. 177.

SECT. III. Antennæ of male thickened and excised at about one-sixth from base; mid tibiæ tufted with hair; hind tibiæ with a large tuft at base and small tuft at extremity.

(4)†SYLEPTA HELCITALIS Wlk. xviii. 574. W. Indies;

†*Botys orphnealis* Wlk. xviii. 736. S. America.

† „ *dracusalis* Wlk. xix. 983.

„ *subæqualis* Wlk. xxxiv. 1394.

SECT. IV. (*Pramadea*). Antennæ of male with a tooth of scales from upperside of basal joint, the shaft excised at base.

(5)*SYLEPTA CURIUSALIS Wlk. xviii. 688. Borneo.

(6)†SYLEPTA DENTICULATA Moore, Lep. Atk. p. 211. N.E. India.

(7)†SYLEPTA CARBATINALIS Swinh. Trans. Ent. Soc, 1890, p. 288,
pl. 8. f. 13. Assam; Burma.

Polycorys seminigralis Warr. A. M. N. H. (6) xviii. p. 172.

(8) SYLEPTA COHÆSALIS Wlk. xxxiv. 1418. India; Sula;
Borneo; Australia; Fiji.

Notarcha halurga Meyr. Trans. Ent. Soc. 1886, p. 259.

Coptobasis biocellata Warr. A. M. N. H. (6) xviii. p. 171.

(9)†SYLEPTA CROTONALIS Wlk. xix. 997. N.E. India; Ceylon.

(10) SYLEPTA LEUCODONTIA, n. sp.

♂. Fuscous with a slight purplish gloss. Fore wing with indistinct dark antemedial line bent outwards to inner margin;

large dark orbicular and reniform spots in cell situated on a pale streak; the postmedial line curved from costa to vein 2, defined by whitish in the form of finer teeth below costa, points at median nervules, at vein 2 retracted to below angle of cell, then angled outwards above vein 1. Hind wing with dark discoidal spot on a pale ground; the postmedial line white, formed by a prominent white spot below costa, bent outwards and dentate between veins 5 and 2, then retracted to below angle of cell.

♀. Both wings with the ground-colour pale brownish to the postmedial line, which is prominent, blackish, and more strongly defined by white on outer side.

Hab. Celebes; Amboina (*Doherty*); Fergusson I., N. Guinea (*Meek*). Types in Coll. Rothschild and B.M.

(11)†*SYLEPTA FRATERNA* Moore, Lep. Ceyl. iii. p. 292, pl. 181. f. 8.
S. India; Ceylon.

(12)†*SYLEPTA RIDOPALIS* Swinh. Trans. Ent. Soc. 1892, p. 18.
Assam; Burma.

(13) *SYLEPTA LUNALIS* Guen. Delt. & Pyr. Formosa; India,
p. 352. Ceylon, & Burma; Borneo;
Botys thyalis Wlk. xviii. 734. Celebes; Sumbawa;
Coptobasis incrassata Warr. A. M. N. H. Venezuela.
(6) xviii. p. 171.

(14)†*SYLEPTA CONTIGUALIS* Wlk. xxxiv. 1441. Java.
†*Botys subjunctalis* Wlk. xxxiv. 1441.

(15) *SYLEPTA PURPURASCENS*, n. sp.

♂. Dark fuscous suffused with purple; palpi at base, pectus, femora, and ventral surface of abdomen white. Fore wing with antemedial line slightly defined by grey on inner side; a quadrate white spot in end of cell; the postmedial line defined by grey on outer side, with two dentate white marks below costa, strongly excurved between veins 5 and 2, then retracted to below angle of cell, then excurved again. Hind wing with traces of discoidal spot; the medial line excurved between veins 5 and 2, and slightly defined by grey on outer side; a fine pale line at base of cilia.

Hab. British East Africa, Dar-es-Salaam. *Exp.* 36 mm. Type in Coll. Rothschild.

(16)†*SYLEPTA ADDUCTALIS* Wlk. xviii. 669. S. India; Ceylon;
Coptobasis luminalis Led. Wien. Ent. Mon. 1863, Java.
p. 483, pl. 16. f. 10.

(17) *SYLEPTA ARCTALIS* Guen. Delt. & Pyr. p. 296. W. India.
†*Desmia opisalis* Wlk. xvii. 346; Led. Wien. Ent. Mon. 1863,
pl. 16. f. 11.

(18) *SYLEPTA TEXTALIS* Led. Wien. Ent. Mon. 1863, p. 482, pl. 16.
f. 9. N. & W. India; Borneo.
†*Coptobasis aenealis* Swinh. P. Z. S. 1885, p. 867.

(19)†*SYLEPTA ORBIFERALIS*, n. sp.

Pale greyish fuscous with a yellowish tinge; palpi white below. Fore wing with obscure oblique antemedial dark line defined by whitish on inner side and almost obsolete towards costa; a round white orbicular spot and large lunulate discoidal spot; the post-medial line with three conjoined dentate white marks on its outer edge below costa, excurved and more or less strongly defined by white between veins 5 and 2, then retracted to near base of vein 2 and with a white spot in its angle. Hind wing with more or less prominent white discoidal spot; the postmedial line strongly bent outwards between veins 5 and 2, then retracted to near angle of cell and terminating on inner margin above tornus, more or less strongly defined by white on outer side, usually expanding into a dentate patch below costa.

Hab. Karkloof, Natal (*Marshall*). *Exp.* 36 mm.

(20)†*SYLEPTA OVIALIS* Wlk. xviii. 636. W. Africa; Abyssinia;
N.E. India.

(21)†*SYLEPTA SARRONALIS* Wlk. xviii. 636. W. Africa.

(22) *SYLEPTA LACTIGUTTALIS* Warr. A. M. N. H. (6) xvii. p. 131.
Assam; Burma.

(23) *SYLEPTA LUCTUOSALIS* Guen. Delt. & Pyr. p. 290. Siberia;
Botys cæmealis Wlk. xviii. 671. Japan; China; Himalayas;
„ *cosisalis* Wlk. xviii. 685. Andamans; Borneo.
Ebulea zelleri Brem. Ost-Sib. p. 70, pl. 6. f. 12.

†*Coptobasis andamanalis* Moore, P.Z.S. 1877, p. 615, pl. 60. f. 14.

†*Hymenia erebina* Butl. Ill. Het. ii. p. 57, pl. 39. f. 1.

(24)†*SYLEPTA TRICOLOR* Butl. Ill. Het. iii. p. 75, pl. 59. f. 6.
Japan.

(25) *SYLEPTA SEGNALIS* Leech, Entom. 1889, p. 65, pl. 4. f. 4.
Japan.

SECT. V. Antennæ of male thickened and tufted with hair for a short distance near base.

(26)†*SYLEPTA OBLIQUIFASCIALIS* Hmps. Moths Ind. iv. p. 330.
Sikhim; Burma.

(27)†*SYLEPTA PYRANTHES* Meyr. Trans. Ent. Soc. 1894, p. 462.
Borneo.

(28)†*SYLEPTA CHROMALIS* Wlk. xxxiv. 1453. Sikhim; Java.

SECT. VI. Antennæ of male with the basal joint extremely dilated and fringed with scales below; palpi with the 3rd joint long and club-shaped; hind wing with the apical area extremely contorted and forming on underside a sort of tongue lying in an oval depression.

(29)†*SYLEPTA TORSIPEX*, n. sp. (Plate XLIX. fig. 12.)

♂. Ochreous fuscous. Fore wing with obliquely sinuous ante-

medial fuscous line; semihyaline specks in middle and end of cell, and a bidentate spot beyond the end; a dentate fuscous postmedial line excurved between veins 5 and 2, then retracted to below end of cell. Hind wing with postmedial fuscous line bent outwards and dentate between veins 5 and 2, then retracted and oblique to near tornus; the tongue-shaped apical fold fuscous.

Hab. Sierra Leone (*Clements*). *Exp.* 36 mm.

SECT. VII. Antennæ of male normal.

- A. Fore tarsi of male with the 1st joint fringed on both sides with long hair; mid tibiæ dilated and fringed with hair on outer side, as also the 1st joint of tarsus.

(30)†*SYLEPTA CLEMENTSI*, n. sp. (Plate XLIX. fig. 11.)

Head yellow, the 2nd joint of palpi black above, a black spot between antennæ; thorax and abdomen orange-yellow, collar and patagia striped with black, abdomen with black dorsal patch on subterminal segment. Fore wing with the basal area and costa yellow; subbasal and curved antemedial black bands; a quadrate black spot in cell; whitish patches in and below cell; outer half of wing black with purplish gloss; a postmedial whitish band attenuate in discal fold, angled inwards above vein 2 and terminating just below it; a quadrate whitish patch on costa before apex; a yellowish mark on margin above outer angle in male. Hind wing pale yellow; oblique antemedial, medial, and submarginal black bands, the two latter meeting near anal angle, the medial expanding towards costa, and the submarginal arising from a large apical patch; a marginal band.

Hab. Sierra Leone (*Clements*). *Exp.* 42 mm. Types in B.M. and Coll. Schaus.

- B. (*Herpetogramma*). Fore tibiæ of male tufted with hair.

(31)†*SYLEPTA PATAGIALIS* Zell. Lep. Caffr. p. 37. S. America.
Herpetogramma servalis, Led. Wien. Ent. Mon. 1863, p. 430,
pl. 16. f. 16.

(32)†*SYLEPTA CERESALIS* Wlk. xviii. 581. Haiti.
Botys candacalis, Feld. Reis. Nov. pl. 135. f. 47.

- C. (*Patania*). Hind tibiæ of male with a large tuft of hair and long flattened scales on inner side before the medial spurs.

(33)†*SYLEPTA CONCATENALIS* Wlk. xxxiv. 1408. Sikhim.

(34)**SYLEPTA NINGPOALIS* Leech, Ent. xxii. p. 68, pl. iii. f. 1.
Japan.

D. (*Erilusa*). Hind tibiæ of male with fringe of very long hair on outer side and of short hair on inner side as far as the medial spurs.

- (35) SYLEPTA SECTA Wlk. vii. 1652. Brazil.
 †*Erilusa dioptoides* Wlk. xxxiv. 1377.
 „ *radialis* Feld. Reis. Nov. pl. 136. f. 32.
 „ *pseudanuco* Feld. Reis. Nov. pl. 136. f. 30.

E. Mid and hind tibiæ of male fringed with long hair on outer side.

- (36)*SYLEPTA IDMONALIS Druce, Biol. Centr.-Am., Het. ii. p. 240,
 pl. 62. f. 11. Mexico.

F. (*Pantograptæ*). Hind tibiæ of male clothed with long hair on outer side.

- (37) SYLEPTA EXPANSALIS Led. Wien. Ent. Mon. 1863, p. 376,
 pl. 11. f. 12. Centr. Am.; Brazil.
Pantograptæ orsonalis Druce, Biol. Centr.-Am., Het. ii. p. 241,
 pl. 62. f. 14.

- (38) SYLEPTA LIMATA Grote & Rob. Ann. N. Y. Lyc. viii. p. 464,
 pl. 16. ff. 16, 17. U.S.A.; Mexico; Centr. Am.; Brazil.
Pantograptæ suffusalis Druce, Biol. Centr.-Am., Het. ii. p. 240,
 pl. 62. f. 10 (subsp.).

- (39) SYLEPTA SCRIPTURALIS Guen. Delt. & Pyr. p. 373. Brazil.

- (40)†SYLEPTA ACÆTESALIS Wlk. xix. 1011.
 Panama; Ecuador; Bogota.
Pantograptæ cybelealis Druce, Biol. Centr.-Am., Het. ii. p. 240,
 pl. 61. f. 8.

G. (*Crocidocnemis*). Hind coxæ of male with tufts of long black hair.

- (41)†SYLEPTA PELLUCIDA Warr. Trans. Ent. Soc. 1889, p. 269.
 Brazil.
 (42)*SYLEPTA GORGONALIS Druce, Biol. Centr.-Am., Het. ii. p. 240,
 pl. 62. f. 13 (♀). Mexico.

H. Hind tibiæ of male fringed with long black hair on outer side; abdomen with paired tufts of black hair from base below; hind wing with large tuft of black hair from inner margin near base.

- (43) SYLEPTA TIBIALIS Moore, Lep. Atk. p. 216. N.E. & S. India.

I. Hind tibiæ of male with the inner spurs extremely long; abdomen with lateral fringes of hair on basal segments; hind wing with the apex greatly produced.

- (44) SYLEPTA FABIUSALIS Wlk. xviii. 715.
 Borneo; Pulo Laut; Bourou.

J. Legs of male normal.

a. (Epherema). Fore wing of male with large fovea, and the membrane extremely contorted below the cell.

(45) *SYLEPTA ABYSSALIS* Snell. Tijds. v. Ent. xxxv. p. 172, pl. 10. ff. 11, 12. Java; Amboina; N. Guinea.

b. Retinaculum of male formed by a large fan of white scales.

(46)†*SYLEPTA PAUCISTRIALIS* Warr. A. M. N. H. (6) xvii. p. 139. N.E. India.

c. Hind wing of male with the inner area clothed with rough hair below; the tornus lobed; fore wing long and narrow.

(47) *SYLEPTA MACULALIS* Leech, Entom. 1889, p. 67, pl. 3. f. 11. Japan.

d. Hind wing of male with the tornus tufted with hair.

(48)**SYLEPTA POGONODES*, n. sp.

♂. Yellow; head, thorax, and abdomen towards extremity suffused with rufous; legs banded with rufous. Fore wing with slight rufous marks at base; an antemedial line oblique from costa to below median nervure, where it is angled, then angled inwards on vein 1; a speck in cell and discoidal lunule; the postmedial line broad and irregular, nearly straight from costa to vein 2, then bent inwards to below angle of cell, and with patches between it and lower angle of cell; the termen rather broadly rufous, diffused inwards to the postmedial line at middle; cilia chequered brown and yellow. Hind wing with indistinct postmedial line bent outwards between veins 5 and 2; the terminal area suffused with brown, and the tufts at tornus brown; cilia brown and yellow.

Hab. Batchian, Amboina (*Doherty*). *Exp.* 30 mm. Type in Coll. Rothschild.

e. Wings of male normal.

*a*¹. (*Lipotigris*). Thorax of male with a fan of large scales from origin of fore coxæ.

(49) *SYLEPTA REGINALIS* Cram. Pap. Exot. iv. p. 163, pl. 372. f. C. W. Indies; C. America.

*b*¹. (*Pleuroptya*). Thorax of male with a fan of large scales from origin of hind wing below.

(50) *SYLEPTA BALTEATA* Fabr. Suppl. Ent. Syst. p. 457 (1798). S. Europe; Japan; China; India, *Sylepta aurantiacalis* Fisch. v. Ceylon, & Burma; Sula. Rösl. Abbild. Schmett. p. 213, pl. 75. f. 3.

Botys crocealis Dup. Lép. Fr. viii. p. 365, pl. 235. f. 6.

„ *accipitraris* Wlk. xxxiv. 1422.

„ *mysolalis* Wlk. xxxiv. 1423.

„ *quadriguttalis* Wlk. xxxiv. 1435.

† „ *aurea* Butl. Ill. Het. iii. p. 76, pl. 59. f. 12.

† *Hapalia fraterna* Moore, Lep. Ceyl. iii. p. 338, pl. 183. f. 9.

(51) *SYLEPTA PERNITESCENS* Swinh. A. M. N. H. (6) xiv. p. 203.

Japan; N.E. India.

Pleuroptya fuscalis Warr. A. M. N. H. (6) xviii. p. 165.

(52) *SYLEPTA SOLILUCIS*, n. sp. (Plate XLIX. fig. 13.)

Pale golden yellow; pectus, legs, and ventral surface of abdomen whitish. Fore wing with the costal area fuscous grey in some specimens, yellow in others; the termen fuscous grey, expanding widely towards apex. Hind wing with terminal fuscous-grey line not reaching tornus.

Hab. Humboldt Bay, N. Guinea (*Doherty*). *Exp.* 30 mm. Types in Coll. Rothschild and B.M.

*c*¹. (*Sylepta*). Thorax of male normal.

(53)†*SYLEPTA INSIGNIS* Butl. Trans. Ent. Soc. 1881, p. 587. Japan.

(54) *SYLEPTA PRONAXALIS* Wlk. xviii. 688.

Ceylon; Burma; Borneo.

†*Pardomima acutalis* Hmps. Ill. Het. ix. p. 171, pl. 174. f. 16.

(55)†*SYLEPTA CHALYBIFASCIA* Hmps. Moths Ind. iv. p. 330.

Assam.

(56)**SYLEPTA HYALESCENS*, n. sp.

♂. Pale yellowish brown; anal tuft tinged with rufous; wings thinly scaled, the veins brown. Fore wing with fuscous subbasal mark on inner margin; an antemedial oblique line; a discoidal lunule; the postmedial line oblique from costa to vein 2, where it is retracted to angle of cell, then oblique to inner margin near antemedial line; termen fuscous. Hind wing with discoidal bar; the postmedial line oblique from costa to vein 2, where it is retracted to angle of cell, and reaching inner margin near tornus; termen fuscous; cilia grey at tips.

Hab. Niger, Warri (*Roth*). *Exp.* 28 mm. Type in Coll. Rothschild.

(57)**SYLEPTA COMETA* Warr. A. M. N. H. (6) xviii. p. 164. Assam.

(58)†*SYLEPTA PICALIS*, n. sp. (Plate XLIX. fig. 14.)

♂. Head and tegulæ fuscous, vertex of head with a whitish patch; thorax white; abdomen white, banded with black above; wings white, the veins strongly streaked with black. Fore wing with the costal area black; a black spot near base of inner margin; an oblique black streak between vein 1 and middle of inner margin; a short streak below base of vein 2 and spots in cell and on disco-

cellulars; the terminal third of wing black tinged with purplish grey. Hind wing with discoidal black spot; a postmedial line excurved between veins 5 and 2; cilia black and white on inner half of wing.

♀. With the white area rather more extensive; fore wing with small white postmedial spots above and below vein 7.

Hab. Khásis. *Exp.* 48 mm.

(59)†*SYLEPTA GASTRALIS* Wlk. xxxiv. 1356. Himalayas; Assam.

(60) *SYLEPTA SILICALIS* Guen. Delt. & Pyr. p. 349. Mexico;
Botys cypræalis Wlk. xviii. 596. Centr. Am.; Brazil.

†*Hapalia sublutalis* Warr. Trans. Ent. Soc. 1889, p. 285.

Condylorrhiza sublutalis Druce, Biol. Centr.-Am., Het. ii.
p. 211, pl. 60. f. 26.

(61)†*SYLEPTA BIPARTALIS*, n. sp.

♂. Head, thorax, and abdomen orange, the last fuscous grey towards extremity. Wings with the basal area orange-yellow, the outer two-thirds fuscous grey with a golden gloss; fore wing with the medial portion of a fuscous subbasal line, a speck in cell and discocellular lunule; the costa ochreous.

Hab. Pulo Laut (*Doherty*). *Exp.* 38 mm.

(62)†*SYLEPTA SCINISALIS* Wlk. xviii. 648.

Himalayas; Assam; Burma.

Botys restrictalis Snell. Trans. Ent. Soc. 1890, p. 584 (var.).

(63)†*SYLEPTA COSTALIS* Moore, Lep. Atk. p. 221. N.E. India.

(64) *SYLEPTA SELLALIS*, Guen. Delt. & Pyr. p. 330.

N.E. India; Burma; Malayan subregion.

Botys disjunctalis Wlk. Char. Undescr. Het. p. 96.

(65)†*SYLEPTA BIPUNCTALIS* Warr. P. Z. S. 1888, p. 333.

N.W. Himalayas.

(66) *SYLEPTA VERECUNDA* Warr. A. M. N. H. (6) xviii. p. 167.

India; Ceylon; Sikhim.

Botyodes fraterna Moore, Lep. Atk. p. 221, pl. 7. f. 16
(preocc.).

(67) *SYLEPTA ANGUSTALIS* Snell. Trans. Ent. Soc. 1890, p. 585.

N.E. India.

(68)†*SYLEPTA MNEMUSALIS* Wlk. xviii. 593.

Brazil.

Botys sanguifualis Led. Wien. Ent. Mon. 1863, p. 374,
pl. 11. f. 3.

„ *caudalis* Feld. Reis. Nov. pl. 135. f. 45.

(69)†*SYLEPTA PHILETALIS* Wlk. xviii. 621.

Brazil.

Botys palmalis Feld. Reis. Nov. pl. 135. f. 33.

(70) *SYLEPTA LATICALIS* Led. Wien. Ent. Mon. 1863, p. 375, pl. 11.

f. 14.

Bogota.

- (71)†*SYLEPTA CEPHALIS* Wlk. xviii. 623. Venezuela.
 (72) *SYLEPTA ANGULIFERA* Druce, Biol. Centr.-Am., Het. ii. p. 222,
 pl. 61. f. 14. Centr. & S. America.
 (73) *SYLEPTA STRIGINERVALIS* Guen. Delt. & Pyr. p. 341, pl. 10.
 f. 5. Brazil.
 (74) *SYLEPTA POLYDONTA*, n. sp.

Straw-yellow; pectus, legs, and ventral surface of abdomen white. Fore wing with more or less developed fuscous marks at base; the antemedial line strongly bent outwards on median nervure, then angled inwards in submedian interspace and outwards on vein 1; a prominent black discoidal lunule; the postmedial line strongly dentate, slightly bent outwards between veins 5 and 3, then retracted to below angle of cell and bent outwards again. Hind wing with prominent black discoidal lunule; a strongly dentate postmedial line, slightly bent outwards between veins 5 and 3, then retracted to below angle of cell.

Hab. Amboina (*Doherty*); Fergusson I., N. Guinea; Queensland (*Meek*). *Exp.* 32 mm. Types in Coll. Rothschild and B.M.

- (75)†*SYLEPTA OCHRIFUSALIS*, n. sp.

♀. White; thorax and abdomen with patches of fuscous. Fore wing suffused with ochreous, except the cell and medial part of inner area; slight fuscous marks at base; an indistinct antemedial line angled outwards on median nervure, inwards in submedian interspace, and outwards on vein 1; a slight discoidal black lunule; the postmedial line indistinct, bent outwards and minutely dentate between veins 5 and 3, then retracted and angled outwards again; cilia white. Hind wing suffused with ochreous to the postmedial line, except on costa and inner margin; a black discoidal spot; the postmedial line bent outwards between veins 5 and 2; some fuscous suffusion on termen between vein 2 and tornus.

Hab. Fergusson I., N. Guinea (*Meek*). *Exp.* 28–30 mm.

- (76)†*SYLEPTA BELIALIS* Wlk. xviii. 602. S. America.
 †*Botys mollicularis* Wlk. xxxiv. 1398.

- (77) *SYLEPTA RURALIS*, Scop. Ent. Carn. 616. Europe.
Pyralis verticalis Schiff. Wien. Verz. p. 120.
Epicorsia iridialis Hübn. Verz. p. 355.

- (78)†*SYLEPTA PENUMBRALIS* Grote, Can. Ent. ix. p. 106. U.S.A.

- (79) *SYLEPTA SABINUSALIS* Wlk. xviii. 708. India; Ceylon;
 †*Botys imbutalis* Wlk. xxxiv. 1442. Malayan subregion
 † „ *sublitalis* Wlk. xxxiv. 1452. to Solomon Is.
Notarcha butyrina Meyr. Trans. Ent. Soc. 1886, p. 260.
 † „ *dubia* Hmps. Ill. Het. viii. p. 136, pl. 155. f. 16.

- (80)**SYLEPTA FUSCOMARGINALIS* Leech, Ent. xxii. p. 68, pl. iii. f. 4. Japan.
- (81)†*SYLEPTA ULTIMALIS* Wlk. xviii. 659; Hmps. Ill. Het. ix. pl. 172. f. 8. Ceylon; Burma.
- (82) *SYLEPTA OBSCURALIS* Led. Wien. Ent. Mon. 1863, p. 375, pl. 11. f. 9. U.S.A.
- (83)†*SYLEPTA HOMOMORPHA* Meyr. Trans. Ent. Soc. 1894, p. 462. Pulo Laut.
- (84)†*SYLEPTA STREAMINEA* Butl. A. M. N. H. (4) xvi. p. 416 (1875). Natal.
- (85)†*SYLEPTA MYSISSALIS* Wlk. xviii. 634. W. Africa; Assam; S. India.
Gadessa impuralis Warr. A. M. N. H. (6) xviii. p. 167.
- (86) *SYLEPTA DEROGATA* Fabr. Syst. Ent. p. 641. W. Africa; Siberia; Japan; Oriental & Australian regions.
Sylepta multilinealis Guen. Delt. & Pyr. p. 337, pl. 8. f. 11.
†*Zebronia salomealis* Wlk. xvii. 476.
†*Botys otysalis* Wlk. xviii. 723.
† „ *annuligeralis* Wlk. xxxiv. 1424.
„ *basipunctalis* Brem. Ost-Sib. p. 68, pl. 6. f. 8.
- (87) *SYLEPTA IOPHANES* Meyr. Trans. Ent. Soc. 1894, p. 462. Borneo.
- Type.* (88) *SYLEPTA AMANDO* Cram. Pap. Exot. iii. p. 92, pl. 247. f. E. S. America.
Botys amplalis Guen. Delt. & Pyr. p. 330, pl. 10. f. 4.
- (89) *SYLEPTA RHYPARIALIS* Oberth. Et. Ent. xviii. pl. 11. f. 26. China.
- (90)†*SYLEPTA VENUSTALIS* Swinh. A. M. N. H. (6) xiv. p. 199. Assam.
- (91)†*SYLEPTA NIGRIFLAVA* Swinh. A. M. N. H. (6) xiv. p. 199. Sikhim; Assam.
- (92)†*SYLEPTA HECALIALIS* Wlk. xviii. 573. St. Domingo.
- (93)**SYLEPTA CITRINALIS* Druce, Biol. Centr.-Am., Het. ii. p. 224, pl. 61. f. 18 (♀). Mexico.
- (94)†*SYLEPTA ÆCHMISALIS* Wlk. xix. 982. Mexico.
- (95) *SYLEPTA ELEVATA* Fabr. Ent. Syst. no. 325. S. America.
- (96)†*SYLEPTA IOPASALIS* Wlk. xviii. 652; Moore, Lep. Ceyl. iii. pl. 182. f. 14. Formosa; India, Ceylon, & Burma; Malayan
Botys plagiatalis Wlk. xviii. 673. subregion to N. Australia.
„ *boteralis* Wlk. xviii. 716. subregion to N. Australia.
„ *tardalis* Snell. Tijd. v. Ent. 1880, p. 210, & 1883, pl. 7. f. 6.

- Botys orobenalis* Snell. Tijd. v. Ent. 1880, p. 211, & 1883,
pl. 7. f. 7.
- Botyodes leopardalis* Moore, Lep. Atk. p. 221, pl. 7. f. 26.
- Notarcha tenuis* Warr. A. M. N. H. (6) xviii. p. 102.
- (97)**SYLEPTA PRUMNIDES* Druce, Biol. Centr.-Am., Het. ii. p. 212,
pl. 60. f. 28 (♀). Mexico.
- (98) *SYLEPTA PACTOLALIS* Guen. Delt. & Pyr. p. 346. S. America.
Botys quirinalis Wlk. xviii. 609.
- (99)†*SYLEPTA MAGNA* Butl. Ill. Het. iii. p. 74, pl. 59. f. 2. Japan.
- (100) *SYLEPTA MATUTINALIS* Guen. Delt. & Pyr. p. 195.
W. Indies; Brazil.
Botys odiusalis Wlk. xviii. 627.
- (101) *SYLEPTA DISSIPATALIS* Led. Wien. Ent. Mon. 1863, p. 474,
pl. 11. f. 13. N.E. India; Ceylon; Burma.
Samea quinquigera Moore, Lep. Atk. p. 207, pl. 7. f. 14.
- (102) *SYLEPTA INTERNITALIS* Guen. Delt. & Pyr. p. 375.
St. Domingo.
Sathria stercoralis Led. Wien. Ent. Mon. 1863, p. 411,
pl. 15. f. 4.
†*Megaphysa serenatis* Wlk. xxxiv. 1309.
- (103)†*SYLEPTA SIMMIALIS* Wlk. xviii. 735. W. Indies.
†*Pyralis disparalis* Wlk. xxxiv. 1227.
- (104)†*SYLEPTA ONOPHASALIS* Wlk. xviii. 735. W. Indies.
†*Botys thisoalis* Wlk. xviii. 737.
†*Pyralis gryllusalis* Wlk. xix. 915.
- (105) *SYLEPTA ELATHEALIS* Wlk. xviii. 615. Brazil.
Lygropia neglectalis Led. Wien. Ent. Mon. 1863, p. 381.
- (106) *SYLEPTA AMISSALIS* Guen. Delt. & Pyr. p. 351. Brazil.
- (107)**SYLEPTA PURPURALIS* Wlk. xxxiv. 1398. Bogota.
- (108)†*SYLEPTA SUBALBIDALIS* Swinh. A. M. N. H. (6) xiv. p. 201.
Assam.
- (109) *SYLEPTA OGOALIS* Wlk. xviii. 689. Ceylon; Borneo.
†*Coptobasis colomboensis* Moore, Lep. Ceyl. iii. p. 556, pl. 215,
f. 13.
- (110)†*SYLEPTA MEGASTIGMALIS*, n. sp.

♂. Dull brown tinged with fuscous; collar fulvous yellow with black marks in front; abdomen yellow at extremity. Fore wing with basal black spot below costa; an oblique subbasal black line; a black speck in cell; a large black discoidal lunule; an indistinct postmedial line straight from costa to vein 4, then inwardly oblique. Hind wing with dark point at lower angle of cell; both wings with

the cilia grey at tips. Underside of thorax and abdomen and the legs pale yellow; wings whitish with the margins fuscous.

Hab. Sierra Leone (*Clements*). *Exp.* 36 mm. Types in B.M. and Coll. Schaus.

(111)†*SYLEPTA DEFICIENS* Moore, *Lep. Ceyl.* iii. p. 556, pl. 215.
f. 12. Himalayas; Ceylon.

(112)**SYLEPTA MACHINALIS* Feld. *Reis. Nov.* pl. 136. f. 36 (♀).
Moluccas.

(113) *SYLEPTA INFERIOR*, n. n. Japan.
Botys quadrimaculalis Motsch. *Et.* p. 37 (1860), preocc.

(114) *SYLEPTA QUADRIMACULALIS* Koll. *Hüg. Kasch.* iv. p. 492;
Led. Wien. Ent. Mon. 1863, pl. 16. f. 12. Japan;
Himalayas; Assam; Borneo.
Nagia desmialis Wlk. xxxiv. 1320.

(115)†*SYLEPTA NASONALIS*, n. sp.

♀. Head and thorax yellowish brown; abdomen brown, with white band on basal segment. Fore wing yellowish brown; a dark-edged hyaline spot in cell conjoined to one below it; a quadrate spot in end of cell; a dark postmedial line running out to an angle on vein 5, then retracted to below angle of cell, a series of hyaline spots on its outer edge, largest below costa and in sinus; outer area fuscous brown. Hind wing fuscous brown, with antemedial dark line angled on vein 5, and with an irregular hyaline band beyond it, widest at middle and edged by a minutely dentate line: both wings with dark marginal line; the cilia chequered white and brown.

Hab. Natal. *Exp.* 32 mm.

(116)†*SYLEPTA MESOLEUCALIS*, n. sp.

♂. Head, thorax, and abdomen greyish; palpi fuscous except at base; head, thorax, and base of abdomen suffused with fuscous; wings yellowish white, thickly irrorated and suffused with fuscous grey. Fore wing with curved black antemedial line; a sinuous postmedial line excurved from costa to vein 3, then bent inwards to vein 2 and oblique to inner margin; the area between the two lines without fuscous irroration or suffusion from costa to vein 2; a pale-centred discoidal stigma. Hind wing with the costal area and cell pale from base to the postmedial black line, which is sinuous, strongly excurved between veins 2 and 4, and with pale marks on its outer side; a discoidal black spot; a pale line at base of cilia.

Hab. Karkloof, Natal (*Marshall*). *Exp.* 30 mm.

(117) *SYLEPTA ALBIPUNCTATA* Warr. *A. M. N. H.* (6) xvii. p. 133
(1896). Amboina; Queensland.

(118)**SYLEPTA OCHROTOZONA*, n. sp.

Fuscous brown. Fore wing with traces of dentate black antemedial line angled inwards below cell; a discocellular spot; an

indistinct postmedial line minutely dentate from costa to vein 2, then retracted to the cell. Hind wing with postmedial black line ending at tornus, strongly defined on outer side by ochreous, and dentate between veins 5 and 2; both wings with terminal series of ochreous and dark points.

Hab. Cedar Bay, Cooktown, Queensland (*Meek*). *Exp.* 36 mm.
Type in Coll. Rothschild.

- (119)**SYLEPTA NIGRISCRIPITALIS* Warr. A. M. N. H. (6) xvii. p. 100
(1896). Assam; Queensland.
Notarcha paucinotalis Warr. A. M. N. H. (6) xviii. p. 166.
- (120) *SYLEPTA DIOPTALIS* Wlk. xxxiv. 1376. S. America.
†*Erilusa secta* Wlk. xxxi. 313 (preocc.).
,, *pseudauxo* Feld. Reis. Nov. pl. 136. f. 30.
,, *minimalis* Feld. Reis. Nov. pl. 136. f. 33.
- (121)†*SYLEPTA CÆLIVITTA* Wlk. xxxiv. 1377. Brazil.
Erilusa nitealis Feld. Reis. Nov. pl. 136. f. 35.
- (122)†*SYLEPTA CYANEA* Wlk. xxxiv. 1376. Brazil.

Auctororum.

- Botys tardalis* Snell. Tijd. v. Ent. xxiii. p. 210, & xxvi. pl. 7.
ff. 66 a. Celebes.
- ,, *paucilinealis* Snell. Tijd. v. Ent. xxiii. p. 212, & xxvi. pl. 7.
ff. 8, 8 a. Celebes.
- ,, *ruvicolalis* Snell. Tijd. v. Ent. xxiii. p. 213, & xxvi. pl. 7.
ff. 9, 9 a. Celebes.
- Erilusa dianalis* Möschl. Verh. z.-b. Ges. Wien, xxxii. p. 358,
pl. xviii. f. 44. Surinam.
- Asciodes titubalis* Möschl. Abh. Senck. Ges. xvi. p. 303, f. 6.
Porto Rico.
- Notarcha exculta* Lucas, P. Linn. Soc. N.S.W. (2) vii. p. 262.
Australia.
- Coptobasis leonalis* Schaus & Clem. Lep. Sierra Leone, p. 45,
pl. iii. f. 9. Sierra Leone.
- ,, *möllingeri* Snell. Tijd. v. Ent. xxxviii. p. 152, pl. v.
f. 12. Java.
- ,, *spretalis* Led. Wien. Ent. Mon. 1863, p. 430.
Amboina.
- Botys paleacalis* Guen. Delt. & Pyr. p. 331. Syria.
- ,, *perpendicularis* Dup. Léop. Fr. viii. p. 234, pl. 232. f. 5.
France.
- ,, *inanitalis* Led. Wien. Ent. Mon. 1863, pl. 371, p. 9. f. 3.
Amboina.
- ,, *nigrodentalis* Pag. J.B. Nass. Ver. 1884, p. 268, pl. vi. f. 3.
Amboina.

Genus 71. ENDOGRAPHIS.

Endographis Meyr. Trans. Ent. Soc. 1894, p. 464.

Palpi upturned and hardly reaching vertex of head, the 2nd joint broadly rounded with scales in front, the 3rd short, naked

and obtuse; maxillary palpi filiform; frons rounded; antennæ of male ciliated; tibiæ with the outer spurs two-thirds length of inner; abdomen of male with slight paired lateral tufts of very long hair from medial segments. Fore wing with the apex somewhat acute; veins 3, 4, 5 from angle of cell; 7 straight and well separated from 8, 9. Hind wing with the cell short; vein 2 from angle; 3, 4, 5 almost stalked; 6, 7 from upper angle, 7 anastomosing with 8; male with a tuft of hair on inner margin near base, the margin folded over and produced to a point at anal angle.

†*ENDOGRAPHIS ACROCHLORA* Meyr. Trans. Ent. Soc. 1894, p. 465.

Pulo Laut.

Fig. 71.

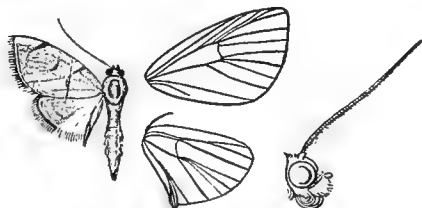

Endographis acrochlora, ♂. $\frac{3}{4}$.

Genus 72. LYGROPIA.

Lygropia Led. Wien. Ent. Mon. 1863, p. 381.

Deuterarcha Meyr. Trans. Ent. Soc. 1884, p. 312.

Haritala Moore, Lep. Ceyl. iii. p. 311 (1886).

Pardomima Warr. A. M. N. H. (6) vi. p. 477 (1890).

Cyclocena Möschl. Abh. Senck. Ges. xvi. p. 309 (1890).

Hyperthalia Warr. A. M. N. H. (6) xvii. p. 134 (1895).

Metoecca Warr. A. M. N. H. (6) xvii. p. 145.

Palpi upturned, the 2nd joint evenly fringed with scales in front, the 3rd short, blunt, and naked; maxillary palpi filiform; frons rounded; antennæ of male ciliated; hind tibiæ with the outer medial spurs about half the length of inner. Fore wing

Fig. 72.

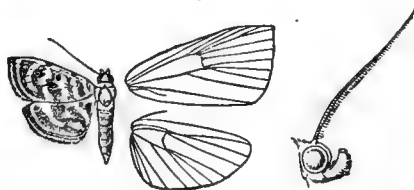

Lygropia quaternalis, ♂. $\frac{1}{2}$. (From Moths Ind. vol. iv.)

short and broad; veins 3, 4, 5 from angle of cell; 7 well separated from 8, 9, to which 10 is closely approximated. Hind wing with the cell short; veins 3, 4, 5 from the angle, 6, 7 from upper angle, 7 anastomosing with 8.

SECT. I. (*Hyperthalia*). Hind wing of male with vesicular hollow on inner area and tuft of long hair on inner margin.

- (1) LYGROPIA FLAVICAPUT Warr. A. M. N. H. (6) xvii. p. 134.
Assam.

SECT. II. (*Cyclocena*). Fore wing of male with large fovea in end of cell.

- (2) LYGROPIA LELEX Cram. Pap. Exot. ii. p. 2, pl. 97. f. C.
Grenada; Porto Rico; Brazil.
Cyclocena gestatalis Möschl. Abh. Senck. Ges. xvi. p. 309, f. 20.
†*Haritala foviferalis* Hmps. A. M. N. H. (6) xvi. p. 335.

SECT. III. Fore wing of male with the retinaculum formed by a large fan of scales.

- (3)†LYGROPIA XANTHOZONALIS Hmps. A. M. N. H. (6) xvi. p. 335.
Grenada.

- (4)†LYGROPIA IMPARALIS Wlk. xxxiv. 1300.

St. Domingo; Curaçoa; Colombia.
Physematia rotundalis Feld. Reis. Nov. pl. 134. f. 40.
Isopteryx flavofuscalis Snell. Tijd. v. Ent. 1887, p. 60, pl. 5.
ff. 3, 4.

SECT. IV. Fore wing of male with a fringe of rough downcurved hair below middle of costa on underside.

- (5)†LYGROPIA RIVULALIS, n. sp.

♂. Yellowish white; head, thorax, and abdomen tinged and marked with brown. Fore wing with three interrupted lines on basal area, the last conjoined to an incurved line of which the two ends are conjoined to two medial lines, connected in places and sending spurs towards two sinuous submarginal lines, terminating on vein 2, which again are connected with the marginal line above middle and outer angle; a line through the cilia. Hind wing with subbasal line; a discocellular spot; a line from lower angle of cell to inner margin; a postmedial line forming an annulus at middle; a submarginal line forking towards costa and ending on the marginal line at vein 2; a line through the cilia.

Hab. U.S.A. (*Grote*). *Exp.* 22 mm.

SECT. V. Fore wing of male with an elongate furrow in cell above, the subcostal nervure curved down towards it.

- (6)†LYGROPIA STRIGILALIS, n. sp.

♂. Uniform orange fulvous; fore tibiæ and tarsi fuscous; wings thinly scaled.

Hab. Espiritu Santo, Brazil. *Exp.* 28 mm.

SECT. VI. (*Lygropia*). Wings normal.

Type. (7) LYGROPIA UNICOLORALIS Guen. Delt. & Pyr. p. 203.

†*Botys acastalis* Wlk. xviii. 600. Honduras; Brazil.

† „ *heronalis* Wlk. xviii. 748.

- (8) *LYGROPIA SIMPLALIS* Guen. Delt. & Pyr. p. 203. Brazil.
- (9)†*LYGROPIA NIGRICORNIS*, n. sp.
♂. Orange; antennæ black; fore tibiæ and tarsi black on outer side; wings uniform orange.
Hab. Abyssinia. *Exp.* 24 mm.
- (10) *LYGROPIA MUSCERDALIS* Zell. Lep. Caffr. p. 43. C. & S. Africa.
- (11)†*LYGROPIA FUSCICOSTALIS* Hmps. A. M. N. H. (6) xvi. p. 334 (♀). Grenada, W. Indies; Brazil.
- (12)**LYGROPIA CERNALIS* Guen. Delt. & Pyr. p. 203. Brazil.
- (13)**LYGROPIA ARMENIACALIS* Wlk. xviii. 536. Brazil.
? *Chromodes armeniacalis* Guen. Delt. & Pyr. p. 312.
- (14)†*LYGROPIA BIPUNCTALIS* Hmps. A. M. N. H. (6) xvi. p. 334 (♀). Grenada, W. Indies.
- (15)†*LYGROPIA OBRINUSALIS* Wlk. xviii. 549; Hmps. Ill. Het. viii. pl. 156. f. 3. N.W. Himalayas; W. & S. India;
Botys trigalis Led. Wien. Ent. Mon. 1863, p. 373, pl. 10. f. 18. Andamans; Nicobars; Borneo; Amboina;
†*Haritala graphicalis* Swinh. P. Z. S. 1886, p. 459. Mexico.
- (16) *LYGROPIA QUATERNALIS* Zell. Lep. Caffr. p. 44.
Botys temeratalis Zell. Lep. Caffr. p. 45. W. & S. Africa;
†*Zebronia cassusalis* Wlk. xvii. 477. Oriental region;
† „ *aurolinealis* Wlk. xvii. 478. Australia.
„ *amœnalis* Wlk. xxxiv. 1352.
Botys faustalis Led. Wien. Ent. Mon. 1863, p. 371, pl. 10. f. 15.
Notarcha chrysoplasta Meyr. Trans. Ent. Soc. 1884, p. 311.
†*Haritala delicatalis* Hmps. Ill. Het. viii. p. 137, pl. 153. f. 6.
- (17) *LYGROPIA CHROMALIS* Guen. Delt. & Pyr. p. 204. Brazil.
Botys principalis Led. Wien. Ent. Mon. 1863, p. 375, pl. 10. f. 17.
- (18) *LYGROPIA ERIXANTHA* Meyr. Trans. Ent. Soc. 1886, p. 258. New Hebrides.
- (19)†*LYGROPIA CLYTUSALIS* Wlk. xviii. 550. Australia.
- (20)†*LYGROPIA POMPUSALIS* Wlk. xviii. 723. Australia.
- (21)†*LYGROPIA AMYNTUSALIS* Wlk. xviii. 662; Moore, Lep. Ceyl. iii. pl. 178. f. 12. India; Ceylon & Burma;
†*Asopia critheisalis* Wlk. xix. 939. Andamans; Java.
†*Botys semizebralis* Wlk. xxxiv. 1407.
† „ *plagiferalis* Wlk. xxxiv. 1452.
Glyphodes testudinalis Saalm. Mittheil. Senckenberg. Naturforsch. Ges. 1879, p. 297.

(35)**LYGROPIA PROGNEALIS* Druce, Biol. Centr.-Am., Het. ii.
p. 235, pl. 62. f. 2. Centr. Amer.

(36)†*LYGROPIA SCYBALISTIA*, n. sp.

♂. Head and thorax ochreous and brown; abdomen whitish, with the anal tuft ochreous. Fore wing brownish, mostly suffused with black; an indistinct curved antemedial line dentate below the cell; a discoidal spot; a whitish patch beyond the cell; a dentate postmedial line defined by whitish on outer side, excurved between veins 5 and 2, then retracted to below end of cell; a blackish patch on costa towards apex; a terminal series of black points. Hind wing white, with terminal brown line and apical patch.

Another specimen has the abdomen more fuscous; fore wing more uniform brownish; hind wing yellowish with more brown on termen; cilia brown at base, white at tips.

Hab. Peru. *Exp.* 26 mm.

Genus 73. AGATHODES.

Agathodes Guen. Delt. & Pyr. p. 207 (1854).

Stenurges Led. Wien. Ent. Mon. 1863, p. 416.

Palpi upturned and hardly reaching vertex of head, the 2nd joint broadly scaled in front, the 3rd porrect and lying on the hair of 2nd joint; maxillary palpi dilated with scales; frons flat; antennæ of male with the shaft nearly simple; mid and hind tibiæ clothed with spinous hair on outer side, the outer spurs less than half the length of inner; abdomen long, male with lateral anal tufts and the claspers and anal tuft extremely developed. Fore wing very long and narrow; the apex produced and the outer margin oblique; veins 3, 4, 5 from lower angle of cell; 7 curved and approximated to 8, 9 for about one-third length; 10 also approximated to 8, 9. Hind wing with the cell long; vein 3 from angle; 4, 5 approximated for a short distance; 6, 7 from upper angle, 7 anastomosing with 8.

Fig. 73.

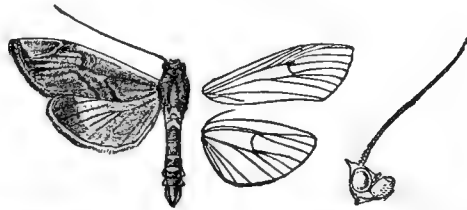

Agathodes orientalis, ♂. †. (From Moths Ind. vol. iv.)

SECT. I. Antennæ of male with the base of shaft dilated and thickened with scales for a short distance.

(1) *AGATHODES DESIGNALIS* Guen. Delt. & Pyr. p. 209.

Florida; S. America.

Stenurges floridalis Hulst, Tr. Am. Ent. Soc. xiii. p. 156.

SECT. II. Antennæ of male normal.

- (2) AGATHODES MONSTRALIS Guen. Delt. & Pyr. p. 209. U.S.A.; Mexico; W. Indies.
- (3) AGATHODES MUSIVALIS Guen. Delt. & Pyr. p. 210. Natal.
- (4) AGATHODES MODICALIS Guen. Delt. & Pyr. p. 210. Burma; Java;
†*Megaphysa integralis* Wlk. xxxiv. 1529.
- Type. (5) AGATHODES OSTENTALIS Geyer, Zutr. ff. 833, 834; Moore, Lep. Ceyl. iii. pl. 215. f. 10. India, Ceylon, & Burma; Malayan subregion to Sumbawa.

Auctororum.

Agathodes caliginosalis Snell, Tijd. v. Ent. xxxviii. p. 147. Java.

Genus 74. GLYPHODES.

- Parotis* Hübn. Samml. Eur. Schmett. iii. p. 30 (1825), non descr.
- Margaronia* Hübn. Verz. p. 358 (1827), non descr.
- Eudiotis* Hübn. Verz. p. 359.
- Phakellura* Poey, Lep. Cuba (1832), non descr.
- Glyphodes* Guen. Delt. & Pyr. p. 292 (1854).
- Margarodes* Guen. Delt. & Pyr. p. 301 (preocc.).
- Hoterodes* Guen. Delt. & Pyr. p. 310.
- Paradosis* Zell. Lep. Caffr. p. 58 (1854).
- Tobata* Wlk. xviii. 516 (1859).
- Dysallaeta* Led. Wien. Ent. Mon. 1863, p. 393.
- Stemorrhages* Led. Wien. Ent. Mon. 1863, p. 397.
- Pachyarches* Led. Wien. Ent. Mon. 1863, p. 398.
- Enchonemidia* Led. Wien. Ent. Mon. 1863, p. 399.
- Sisyrophora* Led. Wien. Ent. Mon. 1863, p. 399.
- Cryptographis* Led. Wien. Ent. Mon. 1863, p. 399.
- Morocosma* Led. Wien. Ent. Mon. 1863, p. 403.
- Chloauges* Led. Wien. Ent. Mon. 1863, p. 405.
- Nolkenia* Snell. Tijd. v. Ent. 1875, p. 222.
- Sestia* Snell. Tijd. v. Ent. 1875, p. 235.
- Cadarina* Moore, Lep. Ceyl. iii. p. 335 (1886).
- Pitama* Moore, Lep. Atk. p. 217 (1887).
- Cenocnemis* Warr. A. M. N. H. (6) xviii. p. 116 (1896).

Fig. 74.

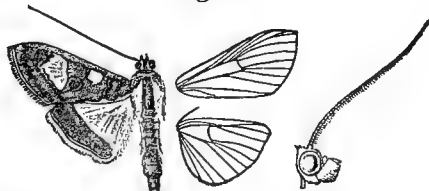

Glyphodes bivitalis, ♂. †. (From Moths Ind. vol. iv.)

Palpi upturned, the 2nd joint broadly scaled in front, the 3rd porrect and lying on the hair of 2nd joint; maxillary palpi tri-

angularly dilated with scales; frons rounded; antennæ of male nearly simple; tibiæ with the outer spurs less than half the length of inner; male with the anal tuft large. Fore wing with the costa highly arched towards apex; veins 3, 4, 5 from angle of cell; 7 curved and closely approximated to 8, 9 for nearly half its length; 10 also approximated to 8, 9. Hind wing with vein 3 from angle of cell; 4, 5 closely approximated for a short distance; the discocellulars slightly angled and nearly erect; 6, 7 from upper angle or shortly stalked, 7 anastomosing with 8.

SECT. I. Antennæ of male with the basal joint dilated; a small tooth at base of inner side of shaft, which is contorted but not thickened.

A. (*Paradosis*). Hind tibiæ of male with the inner medial spur tufted with hair and a tuft between the two pairs of spurs; both wings with the basal half clothed with hair.

(1) GLYPHODES FLEGIA Cram. Pap. Exot. ii. p. 66, pl. 140. D.

W. Indies; S. America.

Margaronia virginalis Hübn. Verz. p. 358.

Margarodes phantasmalis Guen. Delt. & Pyr. p. 310.

Paradosis villosalis Zell. Lep. Caffr. p. 58.

B. (*Sisyrophora*). Hind tibiæ of male fringed with hair on outer side and with a tuft on inner side near the medial spurs.

(2) GLYPHODES PFEIFFERÆ Led. Wien. Ent. Mon. 1863, p. 399, pl. 13. f. 13.

N.E. India; Burma; Andamans;

Cydalima elwesialis Snell. Trans. Ent. Singapore; Sumatra.

Soc. 1890, p. 607, pl. xix. ff. 1, 1 a.

SECT. II. (*Margarodes*). Antennæ of male with the basal joint dilated; the base of shaft somewhat thickened and then contorted.

(3) GLYPHODES LATICOSTALIS Guen. Delt. & Pyr. p. 303; Moore, Lep. Ceyl. iii. pl. 182. f. 4.

India; Ceylon; Burma;

Malayan subregion to New Hebrides.

Margarodes nitidicostalis Guen. Delt. & Pyr. p. 303.

Margaronia leodicealis Wlk. xviii. 530.

SECT. III. Antennæ of male with four caliciform teeth enclosing a hollow at base of shaft, which is much bent and contorted for about one-fourth length and with a small angulation at end of contorted portion; hind legs with a large tuft of hair on outer side of 1st joint of tarsus.

(4)† GLYPHODES OPHICERALIS Wlk. xxxiv. 1440.

Assam; Burma; Java.

SECT. IV. Antennæ of male slightly excised at base.

(5)†GLYPHODES FLAVICAPUT, n. sp.

♂. Silvery grey; head and collar pale bright yellow; anal tuft large and black; wings with the veins brown.

Hab. Rio Janeiro, Brazil. *Exp.* 32 mm.

(6)*GLYPHODES ALBICEPS Feld. Reis. Nov. pl. 135. f. 36. Bogota.

SECT. V. Antennæ of male with the basal joint dilated and with a tuft of hair from its extremity, the shaft given off from its inner side and excised at origin.

A. (*Arthroschista*). Antennæ of male with the shaft thickened on upperside after the excision.

(7)†GLYPHODES HILARALIS Wlk. xviii. 532; Hmpsn. Ill. Het. ix. pl. 173. f. 21. India, Ceylon, & Burma; Sumatra; *Margaronia aquosalis* Snell. Lep. Midd.-Sum. p. 66. Borneo.

(8) GLYPHODES TRICOLORALIS Pag. J.B. Nass. 1888, p. 190. Borneo; Amboina.

B. Antennæ of male with the shaft not thickened on upperside after the excision.

a. (*Pachyarches*). Fore wing of male with a fringe of long hair on basal half of costa below.

(9) GLYPHODES MARINATA Fabr. Ent. Syst. iii. 2, p. 209. *Glyphodes psittacalis* Hübn. Samml. India, Ceylon, & Burma; Exot. Schmett. iii. p. 30, ff. 523, 524. Malayan subregion to †*Margaronia maliferalis* Wlk. xxxiv. 1363. Australia and Fiji. *Parotis planalis* Warr. A. M. N. H. (6) xviii. p. 117.

(10) GLYPHODES AUROCOSTALIS Guen. Delt. & Pyr. p. 306. W. Indies; S. America. *Glyphodes imitalis* Guen. Delt. & Pyr. p. 306.

(11)†GLYPHODES JAIUSALIS Wlk. xviii. 524. S. America.

(12) GLYPHODES LUSTRALIS Guen. Delt. & Pyr. p. 306. W. Indies; S. America.

b. (*Dysallacta*). Fore wing of male with no fringe of hair on costa below.

(13)†GLYPHODES NEGATALIS Wlk. xvii. 468; Led. Wien. Ent. Mon. 1863, pl. 13. f. 6. India, Ceylon, & Burma; †*Botys monesusalis* Wlk. xviii. 653. Australia. † „ *phanasalis* Wlk. xviii. 727.

SECT. VI. Antennæ of male with a tuft of hair from basal joint; the base of shaft thickened and fringed with hair for a short distance. Fore wing with the basal half of costal area clothed with black scales below and fringed with black hair.

(14)†GLYPHODES ÆQUALIS Wlk. xviii. 533. Borneo.

SECT. VII. Antennæ of male with the basal third fringed with hair on upperside.

(15)**GLYPHODES ZANGISALIS* Wlk. xvii. 504. Assam; Borneo.

(16)†*GLYPHODES SECTINOTALIS*, n. sp. (Plate L. fig. 8.)

♂. Head, thorax, and abdomen white and orange-yellow; anal tuft with dorsal black spot. Fore wing orange-yellow, with white fascia on base of inner area followed by a triangular spot; two oblique lines from basal third of costa meeting at their extremities below cell; an oblique wedge-shaped patch from middle of costa to vein 2; a discoidal lunule with silvery edges and silvery spot below it; a quadrate postmedial patch on costa extending down to vein 5 and with larger patch below it, with its inner and lower edges excised and followed by a curved wedge-shaped patch from costa to vein 3; a bisinuate silvery subterminal line with white on its outer edge; all the white markings with fuscous edges; a terminal series of fuscous striæ and a line through cilia. Hind wing white, with fuscous streak on basal part of vein 2 and point at lower angle of cell; a large terminal yellow patch from below costa to vein 1 *b* with sinuous fuscous inner edge; a silvery maculate band with dark edges, a subterminal waved dark line, a series of terminal points, and the cilia with fuscous line and silvery tips.

Hab. Kapaur, N. Guinea (*Doherty*); Fergusson I., N. Guinea (*Meek*). *Exp.* 26 mm.

(17)**GLYPHODES SEMINIGRALIS*, n. sp. (Plate L. fig. 13.)

♂. White; head, tegulæ, and legs tinged with orange. Fore wing with the apex very produced and falcate; the costal area and outer half fuscous black. Hind wing with fuscous apical patch and terminal line not reaching tornus; some fulvous hair on inner area.

Hab. Niger, Warri (*Roth*). *Exp.* 32 mm.

SECT. VIII. Antennæ of male very much thickened and flattened, the basal half clothed with rough scales; patagia long; hind tibix with tufts of hair from base on inner and outer sides; the inner medial and terminal spurs fringed with hair; abdomen with paired lateral tufts near extremity. Fore wing with some rough hair on costa near base; hind wing with the inner area clothed with rough hair above.

(18)**GLYPHODES ADVENALIS* Snell. Tijds. v. Ent. 1894, p. 38, pl. 6. f. 4. Java.

SECT. IX. (*Stemorrhages*). Antennæ of male contorted and angled at one-third from base.

(19) *GLYPHODES SERICEA* Drury, Ins. ii. 9, pl. 6. f. 1.

W. Africa; Madagascar.

Pyralis polita Cram. Pap. Exot. ii. p. 35, pl. 120. f. A.

Geometra laterata Fabr. Ent. Syst. p. 284.

Margaronia congrualis Hübn. Verz. p. 358.

Botys thalassinalis Boisd. Faun. Madag. p. 116, f. 16.

SECT. X. (*Sestia*). Antennæ of male thickened and with a small tuft of scales at two-thirds from base; abdomen with the anal tuft developed into a large brush of hair and scales.

(20) GLYPHODES EUMEUSALIS Wlk. xviii. p. 513.

W. Indies; Brazil.

Phakellura marianalis H.-S. Ver. Regens. Corr.-Bl. 1871, p. 21.

SECT. XI. Antennæ of male normal.

A. (*Nolckenia*). Fore wing of male with a tuft of long hair on base of costa below; hind tibiæ with tufts of hair on outer side at medial and terminal spurs.

(21)*GLYPHODES MARGARITALIS Snell. Tijd. v. Ent. 1875, p. 224,
pl. 13. ff. 2, 3. W. Indies.

B. Fore wing of male with a tuft of short hair on base of costa below and a fringe of scales in a costal fold extending to middle.

(22)†GLYPHODES BALDERSALIS Wlk. xviii. 527. W. Africa; Natal.

(23)†GLYPHODES ARACHNEALIS Wlk. xviii. 527. W. Africa.

B. Hind wing of male with the inner area clothed below with tufts of hair.

a. (*Enchocnemidia*). Hind tibiæ of male with large thick tufts of black hair on outer side at middle and extremity.

(24) GLYPHODES VERTUMNALIS Guen. Delt. & Pyr. p. 309.

India, Ceylon, Burma;

Margarodes squamopedalis Guen. Delt. Malayán subregion
& Pyr. p. 309. to N. Australia.

†*Margaronia phryneusalis* Wlk. Cat. xviii. p. 531; Moore,
Lep. Ceyl. iii. pl. 182, f. 12.

„ *morvusalis* Wlk. xviii. 533.

† „ *atlitalis* Wlk. xviii. 533.

„ *melanuralis* Wlk. xxxiv. 1363.

„ *proximalis* Wlk. xxxiv. 1364.

† „ *herbidalis* Wlk. xxxiv. 1365.

†*Pachyarches tibialis* Moore, P. Z. S. 1867, p. 4214.

Enchocnemidia fuscitibia Warr. A. M. N. H. (6) xviii. p. 116.

b. (*Cenocnemis*). Hind tibiæ of male without tufts of hair.

a¹. Hind wing with the outer margin evenly curved.

(25)†GLYPHODES MARGINATA Hmps. Ill. Het. ix. p. 169, pl. 173.
f. 23. India; Ceylon; Nicobars; Solomons.

(26)†GLYPHODES CONFINIS, n. sp.

Differs from *marginata* in being small and paler; the hair on underside of hind wing pale green instead of ochreous; the disco-

cellular specks almost obsolete; the cilia whitish in the form from Formosa, pale brown in the Australian form.

Hab. Formosa; Peak Downs, Australia. *Exp.* 28–32 mm.

*b*¹. Hind wing with the outer margin deeply indented at middle.

- (27) GLYPHODES INCURVATA Warr. A. M. N. H. (6) xviii. p. 116.
E. Java; Loyalty Islands.

C. Wings of male normal.

a. Hind tibiae of male with erectile fringe of very long black hair on upperside.

- (28) GLYPHODES BADJALIS Wlk. xviii. 694. Burma; Borneo.

b. Legs of male normal.

*a*¹. (*Morocosma*). Abdomen of male with paired lateral tufts of long hair from 5th segment.

- (29) GLYPHODES MARGARITARIA Cram. Pap. Exot. iv. pl. 367. f. C.
Amboina; Solomon & Duke of York Islands;
„ *crameralis* Guen. Delt. & Pyr. p. 293. Australia.
†*Morocosma polybapta* Butl. A. M. N. H. (5) x. p. 236 (1882).
Glyphodes lineata Lucas, P. Linn. Soc. N. S. W. (2) viii. p. 158.

*b*¹. (*Phacellura*). Abdomen with the anal tuft developed into a large brush of long spatulate scales.

- (30) GLYPHODES FUMOSALIS Guen. Delt. & Pyr. p. 300. Ecuador.

- (31) GLYPHODES FIMALIS Led. Wien. Ent. Mon. 1863, p. 401, pl. 13.
f. 16. Mexico; Venezuela.

- (32) GLYPHODES SATANALIS Snell. Tijd. v. Ent. 1875, p. 231, pl. 13.
f. 6. S. America.

- (33)†GLYPHODES DOHRNI Led. MS.

♂. Black-brown; palpi white below; anal tuft ochreous and black. Fore wing with a hyaline white patch beyond the cell, with sinuous inner edge and minutely dentate outer edge, connected with the inner margin by a sinuous line. Hind wing with hyaline white patch beyond the cell narrowing to a point above inner margin.

Hab. S. America. *Exp.* 32 mm.

- (34) GLYPHODES LATILIMBALIS Guen. Delt. & Pyr. p. 296.

Amazon.

- (35) GLYPHODES EXCLUSALIS Wlk. xxxiv. 1361.

Brazil.

- (36)†GLYPHODES TERMINALIS Maasen, Stübel's Reise, p. 170, pl. ix.
f. 17. Ecuador.

- (37)*GLYPHODES CUMALIS Druce, Biol. Centr.-Am., Het. ii. p. 232,
pl. 61. f. 27. Costa Rica.

(38)†GLYPHODES ALBICINCTA, n. sp.

♂. Differs from *annulata* in the markings of fore wing being reduced to a discocellular speck and bracket-shaped mark beyond the cell extending to vein 2. Hind wing with a medial band narrowing from the costa to a point on vein 2, slightly angled outwards at lower angle of cell.

Hab. São Paulo, Brazil. *Exp.* 26 mm.

(39) GLYPHODES OLEALIS Feld. Reis. Nov. pl. 135. f. 35.

Florida; S. America.

(40) GLYPHODES ARGUTA Led. Wien. Ent. Mon. 1863, p. 401, pl. 13. f. 15. Brazil.

(41)†GLYPHODES OCHRIVITRALIS, n. sp.

♂. Head, thorax, and abdomen brown and pale yellow; palpi white at base below. Fore wing with the basal half brown, extending to end of cell and retracted below lower angle of cell; a subbasal yellow patch on inner area; a hyaline yellow postmedial band extending between veins 5 and 2 nearly to the margin, then retracted and narrow towards inner margin; the marginal area brown. Hind wing yellow hyaline, with marginal brown band broad on apical area.

Hab. Rio Janeiro. *Exp.* 30 mm.

(42) GLYPHODES AURICOLLIS Snell. Tijd. v. Ent. 1875, p. 231, pl. 13. f. 5. Colombia; Ecuador.

(43) GLYPHODES NITIDALIS Cram. Pap. Exot. iv. p. 160, pl. 371. f. F. U.S.A.; W. Indies; S. America.

Diaphania vitralis Hübn. Zutr. i. 20, p. 51, ff. 101, 102.

Eudiptis praxialis Druce, Biol. Centr.-Am., Het. ii. p. 231, pl. 61. f. 28.

(44) GLYPHODES ELEGANS Möschl. Lep. Portorico, p. 299.

W. Indies; S. America.

(45) GLYPHODES INFIMALIS Guen. Delt. & Pyr. p. 298. U.S.A.

†*Phakellura immaculalis* Wlk. xviii. 510.

(46) GLYPHODES FUSCICAUDALIS Möschl. Surinam, p. 429.

S. America.

(47) GLYPHODES LUCIDALIS Hübn. Verz. p. 359.

W. Indies; S. America.

Phakellura plumbidorsalis Guen. Delt. & Pyr. p. 298.

„ *immaculalis* Guen. Delt. & Pyr. p. 297.

(48) GLYPHODES TRANSLUCIDALIS Guen. Delt. & Pyr. p. 299.

Ecuador; Brazil.

Phakellura guenealis Snell. Tijd. v. Ent. 1875, p. 233.

(49) GLYPHODES SUPERALIS Guen. Delt. & Pyr. p. 299. Brazil.

Phakellura gigantalis Snell. Tijd. v. Ent. 1875, p. 234, pl. 13. ff. 7, 8.

(50)†GLYPHODES NIVEOCILIA Led. MS.

Head and thorax black-brown; palpi white below; metathorax and tips of patagia white; abdomen white, the two terminal segments and the anal tuft black; wings as in *hyalinata*.

Hab. Florida; Barbados; S. America. *Exp.* 32 mm.

(51) GLYPHODES ARGEALIS Wlk. xviii. 522.

Brazil.

Margaronia auricostalis Wlk. Trans. Ent. Soc. (3) i. 124.

(52)†GLYPHODES COLUMBIANA Led. MS.

Differs from *hyalinata* in the metathorax and dorsum being black, the tips of patagia only white; both wings with the marginal band crenulated with small points on the veins; cilia dark throughout.

Hab. Colombia. *Exp.* 32 mm.

(53)†GLYPHODES MAGDALENÆ Led. MS.

Differs from *hyalinata* in the marginal band of both wings being crenulated with small points at the veins; the cilia dark throughout.

Hab. Colombia. *Exp.* 30 mm.

(54) GLYPHODES HYALINATA Linn. Syst. Nat. i. p. 874, no. 279.

U.S.A.; W. Indies; S. America;

Pyralis marginalis Cram. Pap. Exot. iv. Natal; Hongkong.
p. 160, pl. 371. f. D.

„ *lucernalis* Hübn. Eur. Schmett., Pyr. f. 108.

(55) GLYPHODES INDICA Saund. Trans. Ent. Soc. 1851, p. 163, pl. 12. ff. 5, 6, 7. Ethiopian, Oriental, & Australian regions.

Phakellura zygenalis Guen. Delt. & Pyr. p. 297.

„ *gazorialis* Guen. Delt. & Pyr. p. 297.

„ *curcubitalis* Guen. Réun. p. 64.

Eudiptis capensis Zell. Lep. Caffr. p. 52.

Botys hyalinialis Boisd. Faun. Madag. p. 117.

c¹. Anal tuft normal.

a². (*Chloauges*). Both wings with the outer margin slightly angled at middle.

(56) GLYPHODES SURALIS Led. Wien. Ent. Mon. 1863, p. 405, pl. 14. f. 7.

Nicobars; Amboina; Pacific groups.

†*Margaronia woodfordii* Butl. A. M. N. H. (5) xv. p. 241
(1885).

(57) GLYPHODES NIGROVIRIDALIS Pag. J.B. Nass. 1888, p. 193.

Amboina.

(58) GLYPHODES ZAMBESALIS Wlk. xxxiv. 1362.

E. Africa;
Madagascar.

b². (*Glyphodes*). Hind wing with the outer margin evenly curved.

(59)†GLYPHODES PERSPECTALIS Wlk. xviii. 515.

Japan; China;
N.W. Himalayas.

Phacellura advenalis Led. Wien. Ent. Mon. 1863, p. 401,
pl. 13. f. 17.

(60)*GLYPHODES ALBIFUSCALIS, n. sp. (Plate L. fig. 12.)

♂. Head and collar fuscous; thorax and abdomen white, the two anal segments mostly fuscous above and the anal tuft black; wings pearly white. Fore wing with broad costal and marginal fuscous bands; a white discocellular spot; the white beyond the cell extending up to vein 7. Hind wing with broad fuscous marginal band narrowing to a point near anal angle.

Hab. Ichang, China. *Exp.* 40 mm.

(61)†GLYPHODES ELEALIS Wlk. xviii. 516. W. Africa.

Cryptographis rogenhoferi Led. Wien. Ent. Mon. 1863, p. 400, pl. 13. f. 14.

Phakellura peridromella Mab. C.R. Ent. Belge, xxv. p. lxiii.

(62)†GLYPHODES STENOCRASPIS Butl. P. Z. S. 1898, p. 442, pl. 33. f. 10. E. Africa.

(63) GLYPHODES HERMESALIS Wlk. xviii. 516. N.E. India; Borneo.
Pitama lativitta Moore, Lep. Atk. p. 217, pl. 7. f. 21.

(64) GLYPHODES UNIONALIS Hübn. Eur. Schmett., Pyr. f. 132. S. Europe; Ethiopian & Oriental

Botys quinquepunctalis Boisd. Faun. regions to Australia. Ent. Madag. p. 117, pl. 16. f. 5.

Margarodes transvisalis Guen. Delt. & Pyr. p. 304.

†*Margaronia claralis* Wlk. xxxiv. 1362.

†*Botys intactalis* Wlk. xxxiv. 1402.

Margarodes septempunctalis Mab. C.R. Ent. Belge, xxiii. p. xxv.

(65) GLYPHODES NIGROPUNCTALIS Brem. Lep. Ost-Sib. p. 67, pl. 6. f. 5. Siberia; Japan; India; Ceylon.

Botys submarginalis Wlk. xxxiv. 1414.

Margaronia neomera Butl. Ill. Het. ii. p. 57, pl. 6. f. 5.

(66) GLYPHODES INNOTATA Druce, Biol. Centr.-Am., Het. ii. p. 228, pl. 61. f. 26. W. Indies; Mexico.

(67) GLYPHODES QUADRISTIGMALIS Guen. Delt. & Pyr. p. 304. U.S.A.; W. Indies; S. America.

(68) GLYPHODES BONJONGALIS Plötz, S. E. Z. 1880, p. 305. W. Africa.

(69)†GLYPHODES OCELLATA, n. sp.

♀. White; head and collar golden brown. Fore wing with the costa golden brown; a brown-edged golden discocellular lunule. Hind wing with traces of discocellular lunule; both wings with indistinct fuscous submarginal line, with two brown specks on it below apex of fore wing and one towards anal angle of each wing.

Hab. Sierra Leone (*Morgan*). *Exp.* 34 mm.

(70)†GLYPHODES WARRENALIS Swinh. A. M. N. H. (6) xiv. p. 148. Assam.

- (71)†GLYPHODES ANNULATA Fabr. Ent. Syst. iii. 2, p. 214. India, Ceylon, & Burma; Borneo.
Glyphodes celsalis Wlk. xviii. 654.
Botys partialis Led. Wien. Ent. Mon. 1863, p. 371, pl. 9. f. 8.
 †*Margaronia usitata* Butl. A. M. N. H. (5), iv. p. 454 (1879).
- (72) GLYPHODES FRATERNA Moore, Lep. Atk. p. 217. Assam.
- (73) GLYPHODES NIGRICOLLIS Snell. Tijd. v. Ent. xxxviii. p. 133, pl. v. f. 9. Java; Celebes; Bali.
- (74)†GLYPHODES SYLEPTALIS, n. sp.
 White; head and tegulæ dark brown. Fore wing with the costa cupreous brown; an obliquely sinuous antemedial line; a spot in cell and large discoidal lunule; the postmedial line more or less reduced to a series of points, bent outwards between veins 5 and 2, then retracted to below end of cell; a large somewhat quadrate apical black-brown patch extending to below vein 4 and a patch at tornus extending up to vein 2. Hind wing with discoidal point; a postmedial maculate line bent outwards between veins 5 and 2; an apical black patch.
Hab. Peru. *Exp.* 34 mm.
- (75)†GLYPHODES HYPOMELAS, n. sp. (Plate L. fig. 9.)
 Silvery white; palpi with the 2nd joint fulvous; abdomen ringed with fuscous towards extremity. Fore wing with the costa fuscous, with a fulvous streak below it; the terminal part of median nervure, the discocellulars, and a streak at base of sub-costals fuscous. Hind wing with the discocellulars fuscous; both wings with fine fuscous marginal line. Underside of fore wing with oblique medial fuscous band composed of streaks in the interspaces of varying length; a broad marginal band; hind wing with large black patch below the cell and at lower angle and broad fuscous marginal band.
Hab. Fergusson I., N. Guinea (*Meek*). *Exp.* 32 mm.
- (76) GLYPHODES PICTICOSTALIS Hmps. Moths Ind. iv. p. 351. Burma; Andamans.
- (77)*GLYPHODES SPURCALIS Snell. Tijd. v. Ent. 1875, p. 224, pl. 13. f. 4. Colombia; Peru.
- (78) GLYPHODES ISOCELALIS Guen. Delt. & Pyr. p. 304. S. America.
 †*Margaronia eribotalis* Wlk. xviii. 524.
- (79)†GLYPHODES NERVOSA Warr. Trans. Ent. Soc. 1889, p. 262. Brazil.
- (80) GLYPHODES AUSONIA Cram. Pap. Exot. ii. p. 66, pl. 140. f. C. W. Indies; S. America.
Margaronia canastralis Hübn. Verz. p. 358.
- (81) GLYPHODES CUPRIPENNALIS Hmps. Moths Ind. iv. p. 351. Borneo; Celebes.

- (82) GLYPHODES AMPHITRITALIS Guen. Delt. & Pyr. p. 307.
N.E. India; Burma; Malayan subregion
Margaronia amphitratialis Wlk. xxxiv. 1363. to Solomons.
- (83) GLYPHODES GLAUCULALIS Guen. Delt. & Pyr. p. 306; Moore,
Lep. Ceyl. iii. pl. 181. f. 2. India, Ceylon, & Burma;
Malayan subregion to Ternate.
†*Margaronia marthesiusalis* Wlk. xviii. 531.
Margarodes nereis Meyr. Trans. Ent. Soc. 1887, p. 271.
- (84) GLYPHODES TRITONALIS Snell. Tijd. v. Ent. xxxviii. p. 131.
W. Africa.
- (85)†GLYPHODES EXAULA Meyr. Trans. Ent. Soc. 1888, p. 213.
Hawaii.
- (86) GLYPHODES THETYDALIS Guen. Delt. & Pyr. p. 308.
St. Domingo.
- (87) GLYPHODES REDUCTALIS Guen. Delt. & Pyr. p. 307.
Colombia.
- (88) GLYPHODES PUNCTALIS Warr. A. M. N. H. (6) xvii. p. 100.
Jamaica; Colombia.
- (89)†GLYPHODES OCEANITIS Meyr. Trans. Ent. Soc. 1886, p. 222.
New Hebrides; Fiji.
- (90)†GLYPHODES ERIBOTESALIS Wlk. xviii. 524. Brazil.
- (91) GLYPHODES POMONALIS Guen. Delt. & Pyr. p. 309; Moore,
Lep. Ceyl. iii. pl. 182. f. 7. China; India; Borneo;
Ceylon; Sumbawa.
- (92)†GLYPHODES NILGIRICA Hmpsh. Moths Ind. iv. p. 350.
S. India.
- (93) GLYPHODES FALLACIALIS Snell. Trans. Ent. Soc. 1890, p. 609.
N.E. India.
- (94) GLYPHODES PUNCTIFERALIS Wlk. xxxiv. 1364. Assam;
New Guinea; Solomons.
- (95)†GLYPHODES PERFECTA Butl. A. M. N. H. (5) x. p. 234 (1882).
New Britain; Duke of York Island.
- (96)†GLYPHODES LACHESIS Butl. A. M. N. H. (5) x. p. 235 (1882).
Duke of York Island.
- (97) GLYPHODES DOLESCHALI Led. Wien. Ent. Mon. 1863, p. 402,
pl. 14. f. 1. Amboina; Australia.
- (98) GLYPHODES CONJUNCTALIS Wlk. xxxiv. 1357. Amboina;
Mysol; New Guinea; Australia.
,, *ledereri* Butl. A. M. N. H. (5) xiii. p. 203 (1884).
- (99)*GLYPHODES METASTICTALIS, n. sp.

♀. Head and thorax black and white; abdomen white, with dorsal black patch on basal segments, the anal tuft black at tip. Fore wing black, with whitish marks on basal inner area; a slightly curved antemedial white line; a quadrate patch in and below middle of cell, with a short streak beyond it above vein 1; a post-medial white band from subcostals to vein 1, expanding below

vein 5; a subterminal line curved from below middle to inner margin; cilia white towards tornus. Hind wing white, with large black discoidal spot extending down to vein 2; the terminal area black with a greyish tinge, its inner edge indented between veins 6 and 2; cilia white at tips.

Hab. S. Celebes (*Doherty*). *Exp.* 22 mm. Type in Coll. Rothschild.

- (100) GLYPHODES QUADRIMACULALIS Brem. Beitr. Faun. Chin. p. 22,
& Lep. Ost-Sib. pl. 6. f. 10. Siberia; Japan; China.
Glyphodes consocialis Led. Wien. Ent. Mon. 1863, pl. 14. f. 2.
- (101) GLYPHODES ORBIFERALIS Hmps. Moths Ind. iv. p. 360.
Assam; Burma.
- (102) GLYPHODES PRINCIPALIS Wlk. xxxiv. 1358.
Pulo Laut; Sumatra.
- (103)† GLYPHODES PROTHYMALIS Swinh. Trans. Ent. Soc. 1892,
p. 19. Assam.
- (104)* GLYPHODES HELICONIALIS Guen. Delt. & Pyr. p. 292.
Venezuela; Cayenne.
- (105)* GLYPHODES CALLIZONA Meyr. Trans. Ent. Soc. 1894, p. 5.
Burma.
- (106)† GLYPHODES ACTORIONALIS Wlk. xvii. 498; Moore, Lep. Ceyl.
iii. pl. 180. f. 1. India; Ceylon; Malayan subregion.
Glyphodes zelleri Led. Wien. Ent. Mon. 1863, p. 478, pl. 14. f. 3.
† „ *conclusalis* Wlk. xxxiv. 1354; Hmps. Ill. Het.
viii. pl. 156. f. 12.
„ *tumidalis* Warr. A. M. N. H. (6) xviii. p. 118.
„ *violalis* Warr. A. M. N. H. (6) xviii. p. 118.
- (107)† GLYPHODES ERNALIS Swinh. A. M. N. H. (6) xiv. p. 148.
Assam; Burma.
- (108) GLYPHODES BICOLOR Swains. Zool. M. (1) ii. pl. 77. f. 2.
S. Africa; Oriental region; Australia.
Eudiotis perspicillalis Zell. Lep. Caffr. p. 53.
Glyphodes diurnalis Guen. Delt. & Pyr. p. 294.
† „ *parvalis* Wlk. xxxiv. 1355.
- (109)† GLYPHODES MINIMALIS Hmps. Moths Ind. iv. p. 359.
Ceylon.
- (110) GLYPHODES MICROTA Meyr. P. Linn. Soc. N. S. W. (2) iv.
p. 1108. Queensland.
- (111)† GLYPHODES DELICIOSA Butl. A. M. N. H. (5) xx. p. 118.
Solomons.
- (112)† GLYPHODES EXCELSALIS Wlk. xxxiv. 1360.
Celebes; Australia; Lifu.
„ *westermanni* Snell. Tijds. v. Ent. 1877, p. 73, pl. 5.
f. 8.
„ *pedenotata* Warr. A. M. N. H. (6) xviii. p. 117.

- (113) GLYPHODES BIVITRALIS Guen. Delt. & Pyr. p. 293; Moore, Lep. Ceyl. iii. pl. 180. f. 2. Oriental region; U.S.A.
Glyphodes abitalis Hulst, Tr. Am. Ent. Soc. xiii. p. 158.
- (114) GLYPHODES ITYSALIS Wlk. xvii. 501; Moore, Lep. Ceyl. iii. pl. 180. f. 4. Oriental region.
" *pierpersialis* Snell. Midd.-Sum. iv. Lep. p. 68.
† " *malayana* Butl. P. Z. S. 1880, p. 684.
- (115) GLYPHODES BASIFASCIALIS, n. sp. (Plate L. fig. 16.)
♂. Head, thorax, and abdomen greyish brown; palpi white at base; abdomen fulvous yellow towards extremity, the anal tuft black. Fore wing with the basal area brown, with oblique dark basal line and dark-edged greyish and fulvous bands on its outer edge; a broad oblique opalescent white medial band followed by a dark-edged fulvous, somewhat figure-of-8-shaped band with dark discoidal lunule and dark-edged greyish mark on it above vein 1; a triangular opalescent postmedial patch from costa to above vein 1, its inner edge excised towards apex; terminal area fulvous, conjoined on inner area to the 8-shaped band and with dark-edged greyish line on it. Hind wing opalescent white, the basal and inner areas tinged with brown; a discoidal lunule; the terminal area yellowish fulvous, diminishing from costa to a point above tornus, two dark lines on its inner edge, brownish towards apex.
Hab. Bathurst, Australia. *Exp.* 38 mm. Types in Coll. Rothschild and B.M.
- (116) GLYPHODES ZELIMALIS Wlk. xvii. 502; Moore, Lep. Ceyl. iii. pl. 215. f. 6. India; Ceylon; Sumatra; Borneo.
Glyphodes nyctalis Snell. Midd.-Sum. Lep. iv. p. 68.
- (117) GLYPHODES EURYTUSALIS Wlk. xvii. 503.
S. India; Ceylon; Borneo.
† " *opalalis* Hmps. Ill. Het. viii. p. 135, pl. 155. f. 20.
- (118) GLYPHODES SABACUSALIS Wlk. xvii. 504 (♀). Borneo; Java.
Talanga delectalis Snell. Tijd. v. Ent. 1894, p. 38, pl. 6. ff. 2, 3.
- (119)*GLYPHODES TALANGALIS, n. sp. (Plate L. fig. 15.)

♀. Head, thorax, and abdomen pale reddish brown and yellowish white. Fore wing with the basal area yellowish white, followed by an oblique antemedial rufous band extending along costa to base; an oblique medial yellowish band; the terminal half rufous, with wedge-shaped yellowish postmedial patch on costa extending down to vein 1; an opalescent whitish discoidal lunule and two subterminal lines with orange between and beyond them. Hind wing yellowish white, with brown and orange subterminal band between veins 5 and 2, with opalescent colours before and beyond it, followed by a terminal yellow patch with two small black-pupilled and black-edged metallic green terminal ocelli, the tips of cilia beyond them black.

Hab. Lifu, Loyalty Islands. *Exp.* 26 mm. Type in Coll. Rothschild.

- (120) GLYPHODES NARALIS Feld. Reis. Nov. pl. 136. f. 38.
Sikhim; Borneo.
† „ *lacteata* Butl. P. Z. S. 1880, p. 685.
- (121)†GLYPHODES AGATHALIS Wlk. xvii. 384. Sumatra.
- (122) GLYPHODES PULVERULENTALIS Hmps. Moths Ind. iv. p. 353.
Assam; Burma.
- (123)*GLYPHODES DYSALLACTALIS Hmps. Moths Ind. iv. p. 353.
Burma.
- (124) GLYPHODES POLYZONALIS, n. sp.

Head whitish, with medial brown stripe; palpi black, white at base and tips; thorax and abdomen yellow-brown, with dorsal and subdorsal white stripes, the anal tuft black. Fore wing with the basal area whitish, with two oblique black streaks on inner area, followed by two oblique lines from costa to just below median nervure; the medial area yellow, with two oblique black-edged whitish bands forming a V-shaped mark, their black edges terminating above vein 1; a black-edged white discoidal bar; the terminal area blackish with three whitish bands, the 1st incurved, the 2nd with purplish middle from below costa to inner margin, the 3rd curved, subterminal, not reaching costa, and broadest at middle; cilia pale with fine line through them. Hind wing whitish, with blackish streak below median nervure and fuscous streaks on inner area; an elliptical discoidal spot; an oblique fuscous medial line ending at tornus; four oblique blackish bands on terminal half, the 1st rather wedge-shaped and ending above tornus, the 2nd incurved, the 3rd narrow and purplish, the 4th broadest at middle; a terminal line and line through the cilia.

Hab. Amboina (*Doherty*); Fergusson I., N. Guinea (*Meek*).
Exp. 30 mm. Types in Coll. Rothschild and B.M.

Type. (125) GLYPHODES STOLALIS Guen. Delt. & Pyr. p. 293, pl. 3. f. 11.
India; Ceylon; Borneo; Australia.

(126)†GLYPHODES QUADRIFASCIALIS, n. sp.

♀. Fulvous brown; palpi white at base; patagia and sides of abdomen marked with white. Fore wing with white spot at base of costa; two oblique black-edged antemedial white bands; a discocellular black-edged white lunule and spot below vein 2; a wedge-shaped oblique postmedial band from costa to vein 2; a submarginal black-edged white line, widening and dentate on outer side towards costa; a submarginal series of silvery marks with diffused black inside them below apex; a marginal black line; cilia whitish. Hind wing with black-edged fulvous discocellular mark; a black-edged white postmedial band; a submarginal silvery line with diffused black on its inner side; a marginal black line; cilia whitish.

Hab. Aburi, W. Africa. *Exp.* 26 mm.

(127) GLYPHODES ECTARGYRALIS, n. sp. (Plate L. fig. 19.)

Head and tegulæ black, fulvous, and white; palpi banded with

black; patagia white; thorax fulvous; legs with fuscous bands; abdomen white, with subdorsal fulvous stripes, the terminal segments fulvous, with segmental white and fuscous bands; anal tuft black. Fore wing fulvous; a black-edged oblique white basal band; similar subbasal and antemedial bands, the latter sometimes crossed by a black streak on vein 1; black-edged spots on discocellulars and vein 2; a wedge-shaped postmedial band from costa to vein 2; a black-edged subterminal line expanding into a bidentate patch below costa; a fuscous patch below apex, and silvery patch from below it to inner margin; cilia black, white towards tornus. Hind wing opalescent hyaline, with black-edged discoidal fulvous patch; the inner area fulvous; the terminal third of wing fulvous and fuscous, with black line on its inner side and silvery terminal line expanding at middle; cilia black, white from middle to near tornus.

Hab. Niger, Warri (*Roth*). *Exp.* 26 mm. Types in Coll. Rothschild and B.M.

(128) GLYPHODES STREPTOSTIGMA, n. sp. (Plate L. fig. 20.)

Head, thorax, and abdomen whitish, with two subdorsal fuscous stripes; palpi with the 2nd joint blackish; abdomen with some orange-fulvous and leaden on dorsum towards extremity, the anal tuft black. Fore wing narrow, semihyaline white; oblique subbasal and antemedial fuscous bands with orange-fulvous centres; an oblique medial fuscous band with a large discoidal ocellus on it, with white centre and fuscous and orange-fulvous rings, below which is a contorted white mark like a spermatozoon with an oblique orange line below it; a large triangular white patch beyond the medial band from costa to vein 3; the outer area fuscous, conjoined to the medial band beyond vein 3, and with orange line near its inner edge from costa to vein 3, followed by a white line reaching inner margin and somewhat dentate towards costa; some white terminal points; the cilia white towards tornus. Hind wing semihyaline white, with short fuscous streaks on base of median nervure and diffused streaks on inner area; an oblique discoidal spot with slight white line on it and with a similar spot placed obliquely below it, sometimes with large white centre; the terminal area fuscous, with nacreous and orange lines not reaching costa or tornus, and followed by a wedge-shaped white subterminal patch between vein 5 and tornus; cilia black, white above and below middle.

Hab. Bonthain, Celebes (*Everett, Doherty*). *Exp.* 40 mm. Types in Coll. Rothschild and B.M.

Subsp. 1. Abdomen without orange and leaden colour towards extremity. Fore wing with the medial and antemedial bands strongly anastomosing above inner margin; the mark below the discoidal ocellus more like an inverted lunule; the white line on terminal area broken up into spots; a wedge-shaped white mark above tornus. Hind wing with the oblique medial spots forming

a band with yellowish centre; the outer of the two lines on terminal area white and both broken and irregular.

Hab. Amboina (*Doherty*). *Exp.* 26 mm. In Coll. Rothschild.

(129)†*GLYPHODES PRYERI*, Butl. A. M. N. H. (5) iv. p. 453 (1879).
Japan.

(130)†*GLYPHODES PYLOALIS* Wlk. xix. 973; Moore, Lep. Ceyl. iii.
pl. 180. f. 3. Japan; China; India, Ceylon, & Burma.
†*Glyphodes sylpharis*, Butl. Ill. Het. ii. p. 57, pl. 39. f. 2.

(131) *GLYPHODES FLAVIZONALIS*, n. sp.

Head, thorax, and abdomen white, tinged in places with yellow and pale brown; anal tuft blackish at extremity. Fore wing pale yellow; a slight fuscous streak below base of costa and spot on inner margin; a whitish antemedial band edged by brownish lines and somewhat dentate on inner side, followed by a subquadrate whitish patch from subcostals to above vein 1; a medial band formed by a dark-edged yellow discoidal spot, constricted at middle and conjoined to an ocellate yellow mark with dark centre and edge; a large reniform postmedial white patch from subcostals to vein 1; the terminal yellow area with two dark lines on its inner edge, enclosing a dentate white spot on costa and small spot on inner margin; the apex suffused with fuscous; a dark marginal line. Hind wing opalescent white, with dark discoidal lunule; the terminal area pale yellow edged by dark lines and narrowing to tornus.

Hab. Queensland (*Mackay*). *Exp.* 24 mm. Types in Coll. Rothschild and B.M.

(132)†*GLYPHODES UMBRIA*, n. sp. (Plate L. fig. 21.)

Pale greyish brown; palpi whitish at base; abdomen with subdorsal black patches on 1st segment and two pairs of obscure striae on following segments; the anal tufts black, with slight brown dorsal tuft. Fore wing with slight black marks on basal area; an antemedial rufous line slightly defined by black; a similar irregular medial band, its outer edge angled on vein 1; a similar postmedial line with waved black edges from costa to vein 2, and with irregularly sinuous and minutely waved black line beyond it curved inwards below its extremity; the discal and terminal areas striated with black, sometimes forming black blotches at middle of terminal area, which is deeper red-brown near tornus; cilia black, yellowish above tornus. Hind wing with the discal area striated with black; a large black-edged rufous discoidal lunule; a black-edged rufous postmedial line obtusely angled at vein 3 and ending above tornus; the terminal area rufous, ending in a point above tornus; a sinuous black line on its inner edge and black patches on it towards apex; a fine black marginal line and line through the cilia, which are yellowish with black patches at apex and middle.

Hab. Fergusson I., N. Guinea (*Meek*). *Exp.* 43 mm. Type B.M.

- (133)*GLYPHODES EVIPPEALIS Wlk. xviii. 622. Brazil.
Botys phryganurus Feld. Reis. Nov. pl. 135. f. 18.
- (134) GLYPHODES BIPUNCTALIS Leech, Entom. xxii. p. 70, pl. iii.
 f. 2. Japan.
- (135)†GLYPHODES CRITHEALIS Wlk. xvii. 344. China; Himalayas.
 ,, *chilka* Mocre, Lep. Atk. p. 216, pl. 7. f. 9.
- (136)†GLYPHODES LACUSTRALIS Moore, P. Z. S. 1867, p. 93, pl. 7.
 f. 11. Sikhim.
- (137)†GLYPHODES CÆSALIS Wlk. xvii. 499; Moore, Lep. Ceyl. iii.
 pl. 183. f. 7. India, Ceylon, & Burma; Andamans.
- (138) GLYPHODES SERENALIS Snell. Tijd. v. Ent. xxiii. p. 233, &
 xxiv. pl. 8. f. 10. Celebes; Queensland.
- (139)†GLYPHODES SIBILLALIS Wlk. xvii. 506. W. Indies;
 ,, *batesi* Feld. Reis. Nov. pl. 135. f. 29. S. America.
- (140) GLYPHODES CANTHUSALIS Wlk. xvii. 505.
 Formosa; India; Andamans; Sumatra.
 †*Botys luciferalis* Wlk. xxxiv. 1412.
 †*Glyphodes lora* Wlk. xxxv. 1978.
 ,, *spectandalis* Snell. Tijd. v. Ent. xxxviii. p. 138,
 pl. vi. f. 1.
- (141)†GLYPHODES PHYTONALIS Wlk. xviii. 698. Borneo.
- (142) GLYPHODES SINUATA Fabr. Spec. Ins. ii. p. 267; Moore,
 Lep. Ceyl. iii. pl. 183, f. 2.
 Ethiopian region; India; Ceylon.
Phalcena marginata Cram. Pap. Exot. iv. pl. 400. I.

Auctorum.

- Eudioptis damalis* Druce, Biol. Centr.-Am., Het. ii. p. 232,
 pl. 61. f. 29. Panama.
- Phakellura fuscicollis* Snell. Tijd. v. Ent. 1875, f. 226. S. America.
- ,, *subauralis* Herr.-Schäff. Ver. Regens. Corresp.-Blatt.
 1871, p. 21. W. Indies.
- ,, *abruptalis* Snell. Tijd. v. Ent. xxxviii. p. 134, pl. v.
 f. 11. Colombia.
- ,, *infernalis* Möschl. Abh. Senck. Ges. xvi. p. 300.
 Porto Rico.
- ,, *grisealis* Maasen, Stübel's Reise, p. 170, f. 18.
 Ecuador.
- Sestia deosalis* Snell. Tijd. v. Ent. xviii. p. 236, pl. xiii. ff. 10, 11.
 W. Indies.
- Margarodes beryttalis* Guen. Delt. & Pyr. p. 307. C. Africa.
- ,, *tritonias* Meyr. Trans. Ent. Soc. 1877, p. 209.
 Australia.
- ,, *minor* Pag. J.B. Nass. Ver. xxxvii. p. 272. Amboina.
- Margaronia convolvulalis* Sepp, Ins. Surinam, i. p. 43, pl. 18,
 Surinam.

- Margaronia angustalis* Snell. Tijds. v. Ent. xxxviii. p. 132, pl. v. f. 8. Borneo.
- Glyphodes cosmarcha* Meyr. Trans. Ent. Soc. 1887, p. 212. Australia.
- „ *boseæ* Saalm. Ber. Senck. Ges. 1879-80, p. 296. Africa.
- „ *nyctalis* Snell. Midd.-Sum. iv., Lep. (1) 8. p. 68. Sumatra.
- „ *jaculalis* Snell. Tijds. v. Ent. xxxvii. p. 177, & xxxviii. pl. v. f. 10. Java.
- „ *megalopa* Meyr. Trans. Ent. Soc. 1889, p. 509. New Guinea.

Genus 75. CLINIODES.

Cliniodes Guen. Delt. & Pyr. p. 300 (1854).

Idessa Wlk. xix. 979 (1859).

Pylartes Wlk. xxvii. 121 (1863).

Basonga Möschl. Abh. Senck. Ges. xiv. p. 79.

Palpi upturned, the 2nd joint broadly scaled in front, the 3rd porrect and lying on the hair of 2nd joint; maxillary palpi dilated with scales; frons flat and oblique; tibiæ with the outer spurs about half the length of inner. Fore wing with veins 3, 4, 5 from close to angle of cell; 7 straight and well separated from 8, 9, to which 10 is approximated. Hind wing with vein 3 from angle of cell; 4, 5 approximated for a short distance; 6, 7 shortly stalked, 7 anastomosing with 8.

Fig. 75.

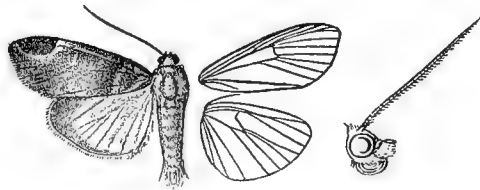
*Cliniodes opalalis*, ♂. †.

SECT. I. Antennæ of male ciliated.

- A. (*Pylartes*). Thorax of male with large tufts of hair and scales from base of fore wing below; mid and hind femora and tibiæ fringed with hair; 1st segment of abdomen with a small dorsal tuft, the proximal segments flattened and with upturned edges, the distal segments with lateral tufts; hind wing with the inner margin greatly lobed and with a large tuft of bent hair near base.

(1)+CLINIODES SUBCOSTALIS Wlk. xxvii. 122.

Borneo.

B. (*Cliniodes*). Thorax, legs, abdomen, and hind wing normal.

(2) CLINIODES CYLLABUSALIS Druce, Biol. Centr.-Am., Het. ii. p. 235, pl. 61. ff. 31, 32. Mexico; Central America.

Type. (3) CLINIODES OPALALIS Guen. Delt. & Pyr. p. 300.
 †*Idessa pyrgionalis* Wlk. xix. 980. W. Indies ; Ecuador.

(4) CLINIODES SABURRALIS Guen. Delt. & Pyr. p. 301.

(5)*CLINIODES EUPHROSINALIS Möschl. Abh. Senck. Ges. xiv. p. 80.
 Jamaica.

SECT. II. (*Basonga*). Antennæ of male thickened and flattened.

(6) CLINIODES RUTILALIS Wlk. Trans. Ent. Soc. (3) i. p. 124.
Glyphodes suavis Feld. Reis. Nov. pl. 136. f. 26. Brazil.

(7) CLINIODES PARADISALIS Möschl. Abh. Senck. Ges. xiv. p. 79,
 f. 26. Jamaica.

Auctorum.

Cliniodes semihumalis Möschl. Abh. Senck. Ges. xvi. p. 279.
 Porto Rico.

„ *paucilinealis* Snell. Tijd. v. Ent. xxxviii. p. 130.
 Colombia.

Genus 76. PYGOSPILA.

Pygospila Guen. Delt. & Pyr. p. 312 (1854).

Phlyctænia Hübn. Verz. p. 259 (1827), non descr.

Lomotropa Led. Wien. Ent. Mon. 1863, p. 304.

Rhagoba Moore, Lep. Atk. p. 217 (1887).

Palpi upturned, the 2nd joint broadly scaled in front, the 3rd porrect and lying on the scales of 2nd joint; maxillary palpi filiform and nearly as long as the labial; frons rounded; antennæ of male minutely ciliated; patagia extending beyond the metathorax; tibiæ with the outer spurs half the length of inner; abdomen long, male with the anal tuft large. Fore wing with the costa arched towards apex, the outer margin oblique; the inner margin lobed before

Fig. 76.

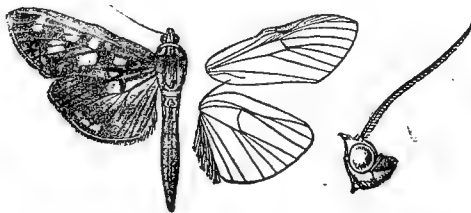

Pygospila costiflexalis, ♂. †. (From Moths Ind. vol. iv.)

middle and somewhat excised towards outer angle; vein 3 from angle of cell; 4, 5 approximated for some distance; 7 curved and approximated to 8, 9; 10 closely approximated to 8, 9. Hind wing with the costa arched at middle; vein 2 from near angle of cell; 3, 4, 5 from angle; 6, 7 shortly stalked and curved, 7 anastomosing slightly with 8.

SECT. I. (*Lomotropa*). Fore wing of male with a postmedial subcostal fold below with close-set fulvous scales, the costa above it crenulate; hind wing with the inner area thickly tufted with fulvous hair.

- (1) *PYGOSPILA COSTIFLEXALIS* Guen. Delt. & Pyr. p. 313; Led. Wien. Ent. Mon. 1863, pl. 14. f. 8. Bombay; S. India; Ceylon; Sumbawa.

SECT. II. Fore wing of male with no distortion of costa; hind wing with the inner margin not tufted.

A. Hind wing of male with vein 8 widely separated from 7 and only touching it at one point, 6 much bent downwards, the veins beyond the cell prominently roughly scaled.

- (2) *PYGOSPILA CUPREALIS* Swinh. Trans. Ent. Soc. 1892, p. 19, pl. 1. f. 4. N.E. India; Burma.
 ,, *evanidalis* Snell. Tijd. v. Ent. xxxix. p. 68 (1896), & xl. pl. 6. ff. 4, 4 a, & 5.

B. (*Pygospila*). Hind wing with vein 8 approximated to 7, 6 slightly curved downwards, 7, 8 slightly roughly scaled below.

- Type.* (3) *PYGOSPILA TYRES* Cram. Pap. Exot. iii. pl. 263. f. C. India, Ceylon, & Burma; Borneo; Java.

C. (*Rhagoba*). Hind wing with veins 6, 7, 8 normal.

a. Hind wing of male clothed entirely with rough woolly hair above.

- (4)**PYGOSPILA BIVITRALIS* Wlk. xxxiv. 1365. Ceram; Obi;
Lomotropa vellerialis Snell. Notes Leyd. Mus. xiii. N. Guinea;
 p. 239, & Tijd. v. Ent. xxxv. pl. x. ff. 9, 10. Queensland.

b. Hind wing of male smoothly scaled.

- (5) *PYGOSPILA OCTOMACULALIS* Moore, P. Z. S. 1867, p. 95. N.E. India.
Rhagoba bimaculata Moore, Lep. Atk. p. 217, pl. 7. f. 21.

Genus 77. HEORTIA.

Heortia Led. Wien. Ent. Mon. 1863, p. 402.

Eteta Wlk. xxxi. 221 (1864).

Tyspana Moore, Lep. Ceyl. iii. p. 256 (1885).

Palpi upturned and reaching vertex of head, the 2nd joint slightly scaled in front, the 3rd porrect; maxillary palpi filiform; frons rounded; antennæ of male almost simple; hind tibiæ with a tuft of hair from base on outer side; build stout. Fore wing with the apex rounded; vein 1 a strongly developed; 3 from before angle

of cell; 7 curved and approximated to 8, 9, to which 10 also is approximated. Hind wing with vein 3 from near angle of cell; 4, 5 from angle; 6, 7 from upper angle, 7 anastomosing with 8.

Fig. 77.

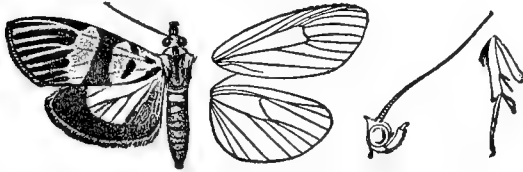

Heortia vitessoides, ♂. †. (From Moths Ind. vol. iv.)

Type. (1) *HEORTIA DOMINALIS* Led. Wien. Ent. Mon. 1863, p. 402, pl. 14. f. 6. Ternate; Ceram.

Eteta sexfasciata Wlk. xxxi. 221.

† *Vitessa triplaga* Wlk. Char. Undescr. Het. p. 8.

(2) *HEORTIA VITESSOIDES* Moore, Lep. Ceyl. iii. p. 256, pl. 178. ff. 3, 3 a. China; India; Ceylon.

Genus 78. EUCLASTA.

Euclasta Led. Verh. zool.-bot. Ges. Wien, 1855, p. 252.

Iturgia Wlk. xviii. 544 (1859).

Palpi upturned, the 2nd joint broadly scaled in front, the 3rd porrect and lying on the hair of 2nd joint; maxillary palpi dilated with scales; frons flat and oblique; antennæ slightly longer than the fore wing and ciliated; legs long, tibiæ with the outer spurs half the length of inner; abdomen long. Fore wing long and narrow, the apex rounded; vein 3 from before angle of cell; 4, 5 well separated at origin; 7 straight and not approximated to 8, 9. Hind wing with the cell more than half the length of wing; vein 3 from angle; 4, 5 closely approximated for a short distance; 6, 7 stalked, 7 anastomosing with 8.

Fig. 78.

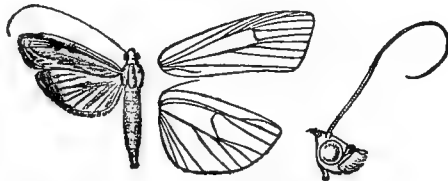

Euclasta defamatalis, ♂. †. (From Moths Ind. vol. iv.)

Type. (1) *EUCLASTA SPLENDIDALIS* H.-S. Eur. Schmett. iv. p. 32, f. 109. E. Europe; Armenia.

(2) *EUCLASTA MACERATALIS* Led. Wien. Ent. Mon. 1863, p. 423, pl. 15. f. 11. New Guinea; Australia.

- (3)**EUCLASTA WARRENI* Distant, Nat. Transvaal, p. 241, pl. ii. f. 5. S. Africa.
- (4)†*EUCLASTA DEFAMATALIS* Wlk. xviii. 544; Hmps. Ill. Het. ix. pl. 174. f. 1. India, Ceylon, & Burma.
- (5) *EUCLASTA FILIGERALIS* Led. Wien. Ent. Mon. 1863, p. 481, pl. 15. f. 14. S. India; Ceylon.

Auctorum.

Euclasta torquittalis Möschl. Abh. Senck. Ges. xvi. p. 302. Porto Rico.

Genus 79. *POLYTHLIPTA*.

Polythlipta Led. Wien. Ent. Mon. 1863, p. 389.

Palpi obliquely upturned, the 2nd joint fringed with long hair below, the 3rd naked and porrect; maxillary palpi filiform; frons rounded; antennæ almost simple and about the length of fore wing; legs very long; mid and hind tibiæ with the outer spurs two-thirds length of inner; abdomen long and slender. Fore wing with veins 3, 4, 5 from angle of cell; 7 curved and approximated to 8, 9 for about one-third length; 10 also closely approximated to 8, 9. Hind wing with the cell short; the discocellulars erect; vein 3 from angle of cell; 4, 5 approximated for a short distance; 6, 7 very shortly stalked, 7 anastomosing with 8.

Fig. 79.

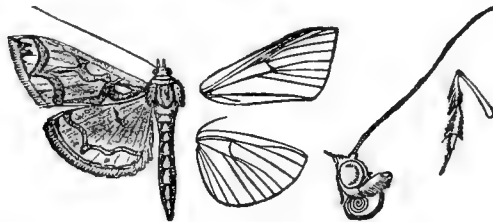

Polythlipta cerealis, ♂. †. (From Moths Ind. vol. iv.)

SECT. I. Fore tibiæ of male fringed with hair on outer side, the 1st joint of tarsus fringed with hair on both sides.

- (1)**POLYTHLIPTA LIQUIDALIS* Leech, Ent. xxii. p. 70, pl. iii. f. 8. Corea; China.
- (2) *POLYTHLIPTA CEREALIS* Led. Wien. Ent. Mon. 1863, p. 477. Himalayas; Assam.
- † „ „ *vagalis* Wlk. xxxiv. 1356.
- (3) *POLYTHLIPTA OSSEALIS* Led. Wien. Ent. Mon. 1863, p. 389, pl. 12. f. 18. N.E. India; Sumatra; Amboina.
- (4)†*POLYTHLIPTA DIVARICATA* Moore, Lep. Ceyl. iii. p. 311, pl. 179. f. 16. Ceylon.

- Type.* (5) POLYTHLIPTA MACRALIS Led. Wien. Ent. Mon. 1863, p. 389,
pl. 12. f. 14. India, Ceylon, & Burma; Amboina.
Polythlipta distorta Moore, Lep. Atk. p. 215, pl. 7. f. 25.
- (6)*POLYTHLIPTA PERAGRATA Moore, Lep. Atk. p. 216, pl. 7. f. 15.
Sikhim.
- (7) POLYTHLIPTA ANNULIFERA Wlk. xxxiv. 1344. Natal.
- (8)†POLYTHLIPTA EUROALIS Swinh. Trans. Ent. Soc. 1889, p. 420,
pl. 44. f. 12. N.E. India; Burma; Sumatra; Java.
Phalangiodes rivulalis Snell. Trans. Ent. Soc. 1890, p. 637,
pl. 20. f. 1.
- (9) POLYTHLIPTA GLOBULIPEDALIS Wlk. xxxiv. 1359.
Celebes; New Guinea.
,, *columalis* Snell. Tijd. v. Ent. 1880, p. 239, &
1884, pl. 4. f. 8.
- (10)†POLYTHLIPTA NODIFERALIS Wlk. xxxiv. 1358. Ceram.

SECT. II. Fore tibiæ and 1st tarsal joint in male not fringed
with hair.

- (11) POLYTHLIPTA INCONSPICUA Moore, Lep. Atk. p. 220.
N.E. India.

Genus 80. LEPYRODES.

Nausinoë Hübn. Verz. p. 362 (1827), non descr.

Lepyrodes Guen. Delt. & Pyr. p. 277 (1854).

Phalangiodes Guen. Delt. & Pyr. p. 278.

Palpi obliquely upturned, the 2nd joint very broadly scaled in front, the 3rd porrect; maxillary palpi filiform; frons rounded; antennæ longer than the fore wing and almost simple; legs long and slender, the outer spurs about two-thirds length of inner. Fore wing with veins 3, 4, 5 normally from angle of cell; 7 straight

Fig. 80.

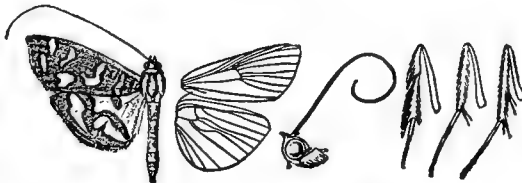

Lepyrodes pueritia, ♂. †. (From Moths Ind. vol. iv.)

and well separated from 8, 9, to which 10 is closely approximated. Hind wing with the cell very short; the discocellulars straight; veins 3, 4, 5 normally from angle of cell; 6, 7 shortly stalked, 7 anastomosing with 8.

SECT. I. (*Phalangiodes*). Fore legs of male with thick tufts of long hair on the tibiæ, the 1st joint of tarsus fringed with long hair on both sides; mid and hind tibiæ fringed on both sides with short hair. Fore wing with veins 4, 5 from above angle of cell and slightly distorted; hind wing with vein 3 from before angle of cell, curved downwards for a short distance, and with a small streak of hyaline membrane above it; veins 4, 5 curved apart near origin, then approaching each other again; 7 curved downwards near origin.

- (1) *LEPYRODES PUERITIA*¹ Cram. Pap. Exot. iii. pl. 264. F. India, *Phalæna perspectata* Fabr. Syst. Ent. p. 640. Ceylon, & Burma; the Malayan subregion; Australia.

SECT. II. (*Lepyrodes*). Male with the fore tibia and 1st joint of tarsus fringed with long hair, but the tibia without thick tufts; neuration normal, and no hyaline streak on hind wing.

- Type.* (2) *LEPYRODES GEOMETRALIS* Guen. Delt. & Pyr. p. 278, pl. 8. f. 6. W. Africa; China; Formosa; India, Ceylon, & Burma; Java; Australia.
- (3) *LEPYRODES CAPENSIS* Wlk. xxxiv. 1344. W. & S. Africa.

Auctorum.

Lepyrodes quadrinalis Guen. Delt. & Pyr. p. 278.

„ *piabilis* Wallengr. Cefv. Ak. Förh. xxxii. 1, p. 122. Central Africa. Transvaal.

Genus 81. *SYLLEPIS*.

Syllepis Poey, Lep. Cuba (1832).

Palpi upturned, the 2nd joint slightly scaled in front, the 3rd minute and porrect; maxillary palpi filiform, frons flat and oblique; antennæ annulate, in male with short fasciculate branches; tibiæ

Fig. 81.

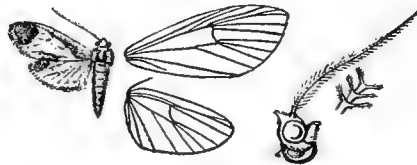

Syllepis marialis, ♂. †.

with the outer spurs half the length of inner; abdomen long. Fore wing narrow; veins 3, 4, 5 from angle of cell; 7 straight and well separated from 8, 9, to which 10 is approximated. Hind

¹ Cramer's plate is wrongly lettered, *v.* description.

wing with veins 3, 4, 5 from angle of cell; 6, 7 from upper angle, 7 anastomosing with 8.

Type. SYLLEPIS MARIALIS Poey, Lep. Cuba. Cuba.
†*Botys hortalis* Wlk. xviii. 609.

Genus 82. ANALYTA.

Analyta, Led. Wien. Ent. Mon. 1863, p. 407.

Palpi with the 2nd joint upturned and moderately fringed with scales in front, the 3rd minute and porrect; maxillary palpi filiform; frons with a rounded prominence; tibiæ with the outer spurs two-thirds length of inner; abdomen with lateral tufts on terminal segments. Fore wing rather narrow; the apex somewhat produced and the outer margin oblique; veins 3, 4, 5 from angle of cell; 7 slightly curved and approximated to 8, 9, to which 10 also is approximated. Hind wing with the cell half the length of wing; veins 4, 5 approximated for a short distance; 6, 7 from upper angle, 7 anastomosing with 8.

Fig. 82.

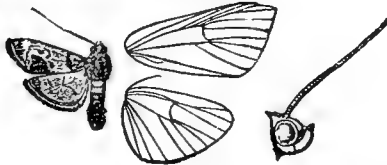

Analyta sigualis, ♂. †. (From Moths Ind. vol. iv.)

SECT. I. Antennæ of male with short uniseriate pectinations, the shaft abruptly downcurved at one-third from base.

- (1) ANALYTA CALLIGRAMMALIS Mab. Bull. Soc. Phil. Paris, 1879,
(2) iii. p. 143. W. Africa.

SECT. II. Antennæ of male laminate.

Type. (2) ANALYTA SIGUALIS Guen. Delt. & Pyr. p. 223.
India; Borneo; Amboina.

Leucinodes heranicealis Wlk. xvii. 394.

Analyta albicilalis, Led. Wien. Ent. Mon. 1863, p. 405.

†*Leucinodes auxialis* Swinh. P. Z. S. 1886, p. 458, pl. 41. f. 12.

- (3) ANALYTA MELANOPALIS Guen. Delt. & Pyr. p. 224. Bombay.
(4)*ANALYTA PUCILLA Druce, Biol. Centr.-Am., Het. ii. p. 263,
pl. 62. f. 27. Centr. Am.

Genus 83. LEUCINODES.

Leucinodes Guen. Delt. & Pyr. p. 221 (1854).

Palpi with the 2nd joint upturned, reaching above vertex of

head and moderately fringed with scales in front, the 3rd long and porrect, the 1st joint with a tuft of projecting hair; maxillary palpi filiform; frons with a rounded prominence; antennæ annulated; tibiæ with the outer spurs two-thirds length of inner; abdomen with lateral tufts on terminal segments. Fore wing rather narrow, the apex somewhat produced and the outer margin oblique; vein 3 from before angle of cell; 4, 5 separate at origin; 7 straight and well separated from 8, 9, to which 10 is approximated. Hind wing with vein 3 from before angle of cell; 4, 5 separate at origin; the discocellulars highly angled; 6, 7 from upper angle, 7 anastomosing with 8.

Fig. 83.

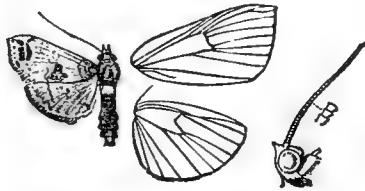

Leucinodes orbonalis, ♂. †. (From Moths Ind. vol. iv.)

- Type.* (1) *LEUCINODES ELEGANTALIS* Guen. Delt. & Pyr. p. 222, pl. 3. f. 8.
W. Indies; S. America.
- (2) *LEUCINODES IMPERIALIS* Guen. Delt. & Pyr. p. 223.
W. Indies; S. America.
- † „ *discerptalis* Wlk. xxxiv. 1313.
- (3) *LEUCINODES ORBONALIS*, Guen. Delt. & Pyr. p. 223; Moore,
Lep. Ceyl. iii. pl. 179. f. 9. S. Africa; India, Ceylon, &
Burma; Andamans; Java; Duke of York Island.
- (4)**LEUCINODES LUCEALIS* Feld. Reis. Nov. pl. 135. f. 3. Brazil.
- (5)**LEUCINODES IMPURALIS* Feld. Reis. Nov. pl. 135. f. 2.
W. Indies.
- (6)†*LEUCINODES DIAPHANA* Hmps. Ill. Het. viii. p. 135, pl. 155.
f. 11. S. India.
- (7)†*LEUCINODES APICALIS* Hmps. Moths Ind. iv. p. 371.
N.W. Himalayas; Ceylon.
- (8) *LEUCINODES VAGANS*¹, Tutt. Ent. Rec. i. p. 203. Transvaal.
†*Aphytoceros longipalpis* Warr. A. M. N. H. (6) ix. p. 391.

Auctorum.

Leucinodes erosialis Pag. J.B. Nass. Ver. xxxvii. p. 281. Amboina.

¹ Type taken in Somersetshire.

Genus 84. METREA.

Metrea Grote, Papilio, ii. p. 73 (1882).

Palpi upturned, the 2nd joint slightly scaled in front, the 3rd porrect; maxillary palpi filiform; frons rounded; tibiæ with the outer spurs half the length of inner. Fore wing with vein 3 from near angle of cell; 4, 5 from angle; 7 well separated from 8, 9, to which 10 is approximated. Hind wing with veins 3, 4, 5 from angle of cell; 6, 7 from upper angle, 7 anastomosing with 8.

Fig. 84.

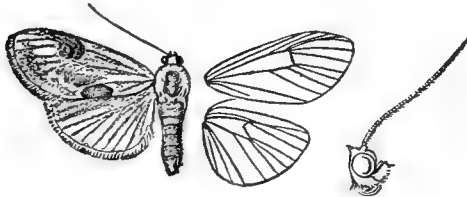

Metrea ostreonalis, ♂. †.

SECT. I. Antennæ of male thickened and minutely serrate to one-third from base, where they are slightly contorted.

(1) METREA NEBULALIS, Wlk. xxxiv. 1353.

Sula; Mysol; N. Guinea.

SECT. II. Antennæ of male ciliated.

(2)†METREA ARIPANALIS, n. sp. (Plate L. fig. 18.)

White; palpi with the extremity of 2nd joint black; tegulæ, patagia, and thorax spotted with black; mid tibiæ black at base and extremity; abdomen with subdorsal black spots on 2nd segment and dorsal band on subterminal segment; wings clouded with pale brown in places. Fore wing with black spot at base of costa; a subbasal series of three spots; the antemedial line represented by spots on costa and inner margin, obsolescent and angled at middle; a speck towards end of cell and large discoidal spot; the postmedial line with spots on costa and inner margin, sinuous, oblique from costa to vein 2, then acutely angled and retracted to below end of cell; a dentate subterminal line developing into a spot at middle, then obsolescent; a terminal series of points, the three near apex developed into elongate spots; a black line through cilia. Hind wing with black discoidal spot; a sinuous postmedial line bent outwards between veins 5 and 2, then retracted to below end of cell; a terminal series of points, two near apex and one between veins 2 and 3 developed into prominent spots; a dark line through cilia.

... Hab. Queensland. Exp. 22 mm.

Type. (3)†METREA OSTREONALIS Grote, Pap. ii. p. 73.

U.S.A.

Botys urticaloides Fyles, Can. Ent. 1894, p. 184.

Genus 85. CROCIDOLOMIA.

Crocidolomia Zell. Lep. Caffr. p. 65 (1854).

Godara Wlk. xix. 808 (1859).

Trischistognatha Warr. A. M. N. H. (6) ix. p. 429 (1892).

Palpi obliquely upturned, with tufts of hair at end of 1st and 2nd joints, the 3rd well developed and obtuse; maxillary palpi dilated with scales at extremity; frons rounded; antennæ of male laminate. Fore wing with a tuft of scales at middle of inner margin; male with a large tuft of hair on upperside from near base of costa recurved over the wing; underside with a fringe of hair below the cell. Hind wing with the cell short; veins 4, 5 approximated for nearly half their length; 3 from angle of cell and approximated to 4, 5 for a short distance; 6, 7 from upper angle; 7 anastomosing strongly with 8, which is highly sinuous.

Fig. 85.



Crocidolomia suffusalis, ♂. †. (From Moths Ind. vol. iv.)

SECT. I. (*Crocidolomia*). Fore coxæ of male very much enlarged, with a leaden-coloured semicircular hollow on inner side with large tufts of white hair on each side of it; mid tibix and the inner spur fringed with long hair on inner side; abdomen with dorsal tuft on 1st segment. Fore wing with vein 3 from before angle of cell; 4, 5 well separated at origin; 10 separated from 8, 9; hind wing of male with a large fovea on underside below the cell before the origin of vein 2.

A. Male with a large subcostal vesicle at base of fore wing on underside, with a thick tuft of short hair from the subcostal nervure just beyond it; the fringe below median nervure short and emitting four strong curved spines playing on the subcostal tuft; hind wing with a membranous bar given off from the end of the fovea at origin of vein 2.

α. Fore wing of male with a slight tuft of long hair at end of the fringe below the cell.

(1)†CROCIDOLOMIA SUFFUSALIS Hmps. Ill. Het. viii. p. 135, pl. 155. ff. 4, 12. India; Ceylon.

b. Fore wing of male with no tuft of long hair at end of the fringe below the cell.

(2)†CROCIDOLOMIA LUTEOLALIS Hmps. Ill. Het. ix. p. 168, pl. 173.
ff. 4, 11. Ceylon.

B. Fore wing of male with no subcostal vesicle; the fringe of hair below the cell long and terminating in a tuft of long hair, no spines arising from it; hind wing with a membranous ridge at end of the fovea.

Type. (3) CROCIDOLOMIA BINOTALIS Zell. Lep. Caffr. p. 65. S. Africa;
Formosa; India, Ceylon, & Burma;
Pioneer comalis, Guen. Delt. & Pyr. p. 368; Java; Australia;
Moore, Lep. Ceyl. iii. pl. 179. f. 2. Norfolk Island.
,, *incomalis* Guen. Delt. & Pyr. p. 369.

SECT. II. (*Trischistognatha*). Legs and wings normal.

(4) CROCIDOLOMIA PALINDIALIS Guen. Delt. & Pyr. p. 380.
†*Botys pyrenealis* Wlk. xviii. 580. W. Indies; S. America.
† ,, *medonalis* Wlk. xviii. 599.

Genus 86. OMMATOSPILA.

Ommatospila Led. Wien. Ent. Mon. 1863, p. 443.

Thelda Wlk. xxxiv. 1221 (1865).

Palpi obliquely upturned, the 2nd joint fringed with long hair in front, the 3rd well developed, naked and blunt; maxillary palpi well developed and filiform; frons flat and oblique; antennæ annulate, in male distorted and with a small tuft of black hair at one half from base; mid tibiæ dilated with a fold containing a tuft of hair; hind tibiæ with the outer spurs half the length of inner, a large tuft of black hair on outer side at medial spurs. Fore

Fig. 86.

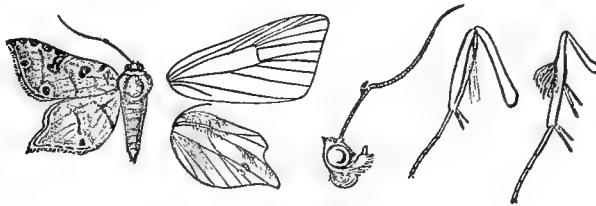

Ommatospila descriptalis, ♂. $\frac{3}{2}$.

wing with vein 3 from near angle of cell; 4, 5 from angle; 7 straight and well separated from 8, 9, to which 10 is approximated. Hind wing with veins 3, 4, 5 from angle of cell; 6, 7 from upper angle, 7 anastomosing with 8; male with the basal half of costa highly arched, and the costal area on underside with fringes of hair; fringes of hair below the cell and on the veins beyond lower angle.

SECT. I. (*Thelda*). Hind wing of male triangular, with the outer margin produced to a long point at middle.

(1)†OMMATOSPILA DESCRIPTALIS Wlk. xxxiv. 1222. St. Domingo.

SECT. II. (*Ommatospila*). Hind wing of male with the outer margin evenly rounded.

Type. (2)†OMMATOSPILA NARCÆUSALIS Wlk. xix. 972. W. Indies; Brazil.
 „ nummulalis Led. Wien. Ent. Mon. 1863, p. 444,
 pl. 17. f. 13.

†*Leucinodes venustalis* Wlk. xxxiv. 1312.

Genus 87. HELLULA.

Hellula Guen. Delt. & Pyr. p. 415.

Palpi obliquely upturned and reaching vertex of head, the 1st and 2nd joints with tufts of scales at extremity; maxillary palpi filiform; frons smooth; antennæ somewhat thickened; legs smooth, the spurs moderate and of even length. Fore wing with vein 3 from near angle of cell; 4, 5 from angle; 10, 11 free. Hind wing with vein 3 from before angle of cell; 4, 5 from angle; 6, 7 from upper angle, 7 anastomosing with 8.

Fig. 87.

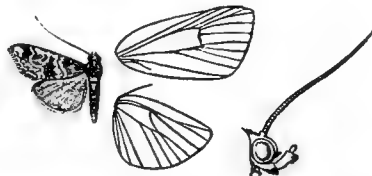

Hellula undalis, ♂. †. (From Moths Ind. vol. iv.)

Type. (1) HELLULA UNDALIS Fabr. Ent. Syst. iii. 2, p. 226; H.-S. Eur. Schmett. iv. pl. 8. f. 54. U.S.A.; Mediterranean

†*Scoparia alconalis* Wlk. xix. 827. subregion; Ethiopian

†*Leucinodes exemptalis*, Wlk. xxxiv. 1313. & Oriental regions.

Botys rogatalis Hulst, Tr. Am. Ent. Soc. xiii. p. 149.

(2) HELLULA HYDRALIS Guen. Delt. & Pyr. p. 461, pl. 10. f. 7.

†*Scopula criasusalis* Wlk. xix. 1016. Australia.

† „ *optatusalis* Wlk. xix. 1018.

†*Pyralis subtrigonalis* Wlk. xxxv. 1244.

(3)†HELLULA PHIDIÆALIS Wlk. xix. 972. W. Indies; S. America.

Auctorum.

Hellula fulvifascialis Christ. Rom. Mem. iii. p. 110, pl. v. f. 8.
 C. Asia.



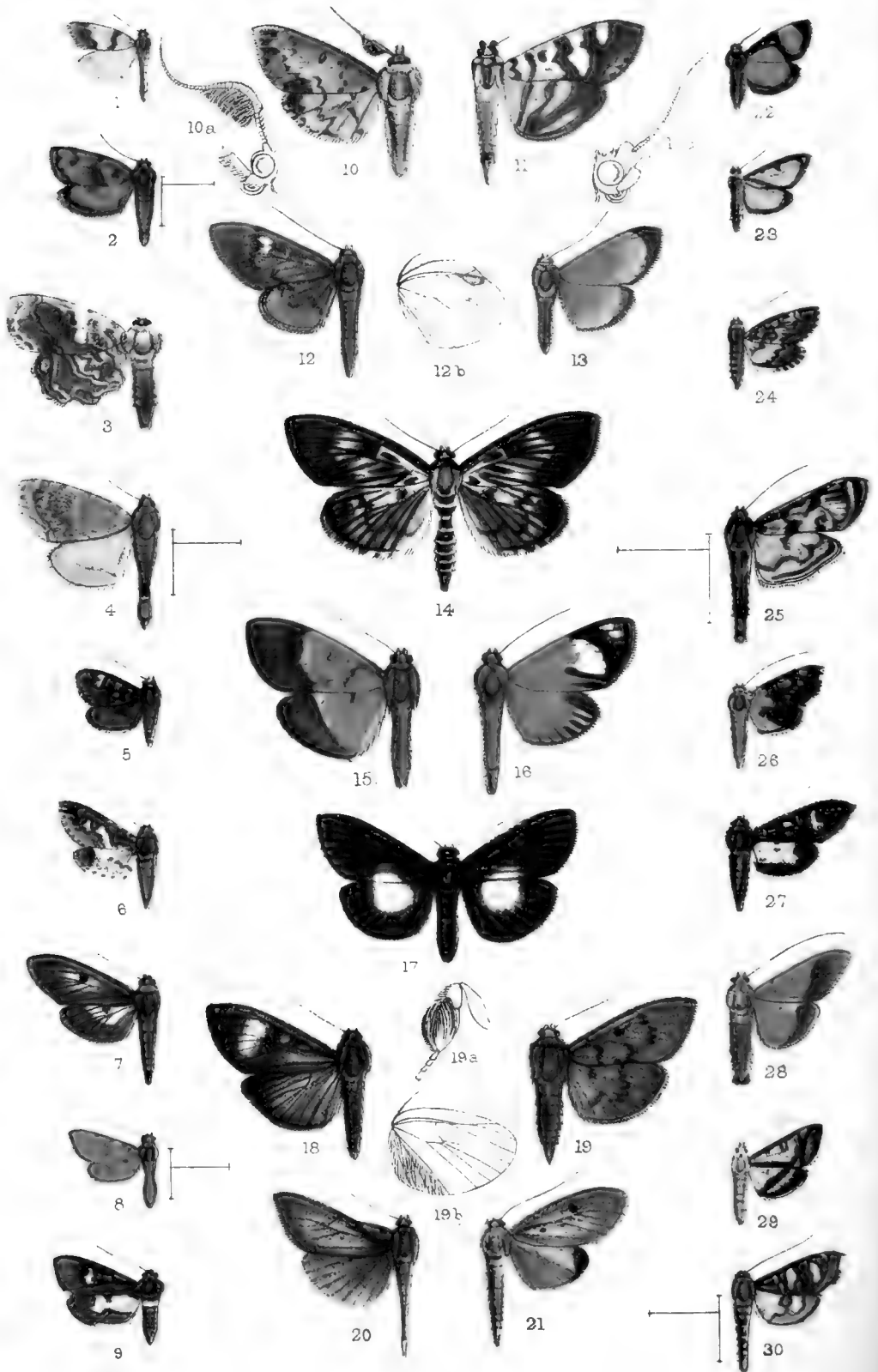

Horace Knight a.d. nat. lith.

West Newman chr.

Pyralidæ of the Subfamily Pyraustinæ.



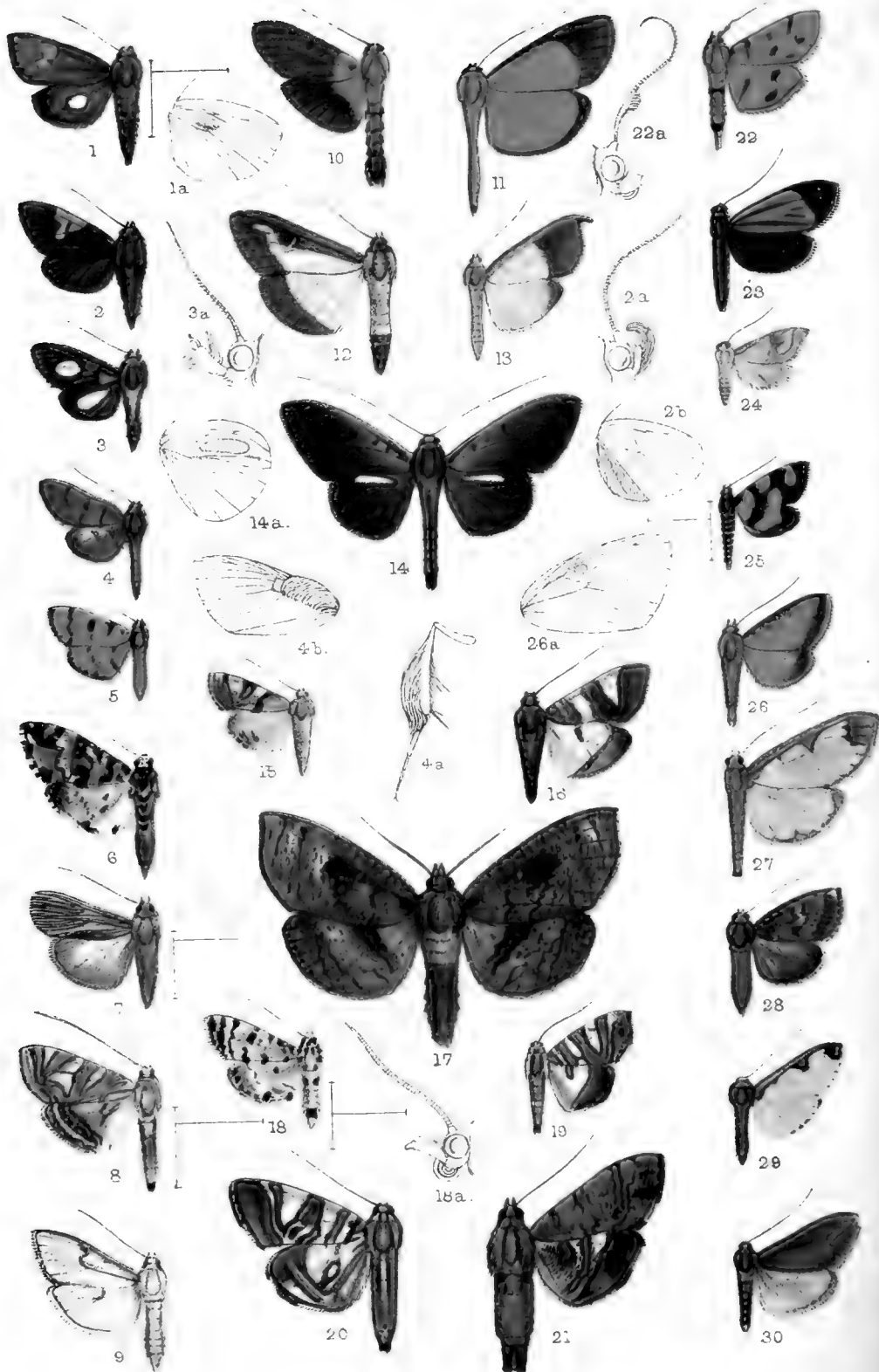

Herace Knight ad nat.lith.

West Newman chr.

EXPLANATION OF THE PLATES.

PLATE XLIX.

- | | |
|---|---|
| <p>Fig.</p> <ol style="list-style-type: none"> 1. <i>Gonodiscus australiensis</i>, ♂, p. 606. 2. <i>Massepha fulvalis</i>, ♂, p. 616. 3. " <i>phœnicobapta</i>, ♂, p. 615. 4. <i>Homophysa polycyma</i>, ♂, p. 607. 5. <i>Tabidia truncatalis</i>, ♂, p. 624. 6. <i>Eurrhyparodes syllepidia</i>, ♂, p. 626. 7. <i>Piletosoma ignidorsalis</i>, ♂, p. 708. 8. <i>Nacoleia progonialis</i>, ♂, p. 696. 9. " <i>junctithyralis</i>, ♂, p. 701. 10. <i>Sylepta plumifera</i>, ♂, p. 712. 11. " <i>clementsi</i>, ♂, p. 716. 12. " <i>torsipez</i>, ♂, p. 715. 13. " <i>solilucis</i>, ♂, p. 719. 14. " <i>picalis</i>, ♂, p. 719. 15. <i>Botyodes fulviterminalis</i>, ♂, p. 710. | <p>Fig.</p> <ol style="list-style-type: none"> 16. <i>Phryganodes perfulvalis</i>, ♂, p. 679. 17. " <i>centralbalis</i>, ♂, p. 681. 18. <i>Pilocrocis leucoplagalus</i>, ♀, p. 658. 19. <i>Phryganodes lanialis</i>, ♂, p. 681. 20. " <i>omphalobasis</i>, ♂, p. 683. 21. " <i>biguttata</i>, ♂, p. 681. 22. <i>Nacoleia semicostalis</i>, ♂, p. 700. 23. <i>Hyalea pallidalis</i>, ♂, p. 642. 24. <i>Syngamia dentilinealis</i>, ♂, p. 645. 25. <i>Rhimphalea astrigalis</i>, ♂, p. 640. 26. <i>Agrotera endoxantha</i>, ♂, p. 628. 27. <i>Desmia melaleucalis</i>, ♂, p. 632. 28. " <i>chryseis</i>, ♂, p. 633. 29. <i>Bocchoris junctifascialis</i>, ♂, p. 650. 30. " <i>flavibrunnea</i>, ♂, p. 651. |
|---|---|

PLATE L.

- | | |
|--|--|
| <p>Fig.</p> <ol style="list-style-type: none"> 1. <i>Chalcidoptera pryeri</i>, ♂, p. 665. 2. <i>Nosophora barbata</i>, ♂, p. 663. 3. " <i>flavibasalis</i>, ♂, p. 663. 4. <i>Phryganodes flocculentalis</i>, ♂, p. 680. 5. <i>Dichocrocis tripunctapex</i>, ♂, p. 691. 6. <i>Conchylodes bryophilalis</i>, ♂, p. 674. 7. <i>Tyspanodes creaghi</i>, ♂, p. 673. 8. <i>Glyphodes sectinotalis</i>, ♂, p. 734. 9. " <i>hypomelas</i>, ♂, p. 740. 10. <i>Filodes flavibasalis</i>, ♂, p. 672. 11. " <i>xanthalis</i>, ♂, p. 672. 12. <i>Glyphodes albifuscalis</i>, ♂, p. 739. 13. " <i>seminigralis</i>, ♂, p. 734. 14. <i>Filodes productalis</i>, ♂, p. 671. 15. <i>Glyphodes talangalis</i>, ♂, p. 743. | <p>Fig.</p> <ol style="list-style-type: none"> 16. <i>Glyphodes basifascialis</i>, ♂, p. 743. 17. <i>Omphisa ingens</i>, ♂. 18. <i>Metrea aripanalis</i>, ♂, p. 757. 19. <i>Glyphodes ectargyralis</i>, ♂, p. 744. 20. " <i>streptostigma</i>, ♂, p. 745. 21. " <i>umbria</i>, ♂, p. 746. 22. <i>Meroctena dichocrosialis</i>, ♂. 23. <i>Noctuelia polystrigalis</i>, ♂. 24. <i>Ischnurges perpulchralis</i>, ♂. 25. <i>Pyrausta tetraplagalis</i>, ♂. 26. <i>Pionea thyriphora</i>, ♂. 27. <i>Sameodes sanguimarginalis</i>, ♂. 28. <i>Mecyna apicalis</i>, ♂. 29. <i>Pyrausta perelegans</i>, ♂. 30. " <i>egcarsialis</i>, ♂. |
|--|--|

[The descriptions of the species figured on Plate L. (fig. 17 and figs. 22–30) will be given in Part II. of this paper, which will be read at a future Meeting.—ED.]

2. List of the Mammals obtained by Mr. R. McD. Hawker during his recent Expedition to Somaliland. By W. E. DE WINTON, F.Z.S.

[Received September 30, 1898.]

The shooting of Lions having been the principal object of this expedition, the means of obtaining specimens of other animals were somewhat curtailed for fear of disturbing the larger game. The expedition was accompanied by Mr. L. C. Harwood, who has brought the collections home in splendid condition: evidence of this is shown in the specimen of Lesser Koodoo now mounted in the Gallery of the British Museum, presented, together with a complete set of the smaller mammals, by Mr. Hawker. The collection

contained also a large number of birds, of which an account will be given in 'The Ibis' together with a map of the route.

1. RHINOLOPHUS ANTINORII Dobs.

In alc. Jifa Medir, 5000 ft., Jan. 1898.

2. TRIÆNOPS PERSICUS Dobs.

In alc. Jifa Medir, 5000 ft., Jan. 1898.

3. VESPERTILIO MINUTUS Temm.

Hargeisa, 3500 ft., 14 Nov., 1897.

"Native name 'Fidmair.'" (*R. M. H.*)

4. CROCIDURA MURINA L.

♀. Aden, Arabia, 7 March, 1898.

"This Shrew was caught in the street at Aden. It was cornered by a dog, and it was making a strange scolding noise when my taxidermist secured it." (*R. M. H.*)

This species has a wide distribution ranging from the Himalayas through India and Burmah, and is found along the coast-line in many parts of the Oriental Region, even in the islands of the Malay Archipelago.

A closely allied form (*C. leucura*) is found in East Africa, but the typical form has never before been recorded west of Bombay.

5. MACROSCELIDES REVOILI Huet.

♂. Arabsiyo, 4000 ft., 30 Nov., 1897.

♂. Arabsiyo, 4000 ft., 1 Dec.

"Very common and to be seen running between the bushes at dusk." (*R. M. H.*)

This species is the only member of the genus yet discovered in Somaliland.

6. FELIS LEO L.

Eleven full-grown Lions were shot, and three cubs brought home alive.

"The lions of Somaliland are divisible into two classes: the cattle-lifters, that follow the villagers in their wanderings, living either on the straying animals that are not brought home in the evening, or by jumping over the zerebas and dragging out sheep (generally fat ones) at night; and the game-hunters, that follow the herds of Hartebeest and other antelopes, but do not come near the villages.

"Lions always carry their prey down wind, and often to a considerable distance before eating it; they then move again down wind to a place where they can sleep without being disturbed by the shepherds.

"We found many of their sleeping-places under thick bushes;

in several of these there was a quantity of long matted hair off their manes which they themselves or their companions pull out to get rid of the grass-seeds." (*R. M. H.*)

7. FELIS PARDUS L.

"Leopards were common on the rocky hills about Hargeisa and were very destructive to the goats and sheep. I saw only one in the daytime, but often heard them at night. They are credited with carrying off many women and children in the Goli ranges, and the skins from that part are certainly larger and finer than those got further south." (*R. M. H.*)

8. FELIS SERVAL Schreb.

"Only seen twice." (*R. M. H.*)

9. FELIS CARACAL Gldenst.

"This animal is common about Hargeisa. It is said by the Somalis to kill a great many sheep and goats. I was brought a half-grown one which was very savage at first, but after a week or so it became fairly tame, and was very much like a cat in its habits and great fondness for milk, of which it would drink quite a quantity and seemed to prefer it to anything else." (*R. M. H.*)

10. FELIS (CYNÆLURUS) JUBATA Erxleb.

"The Cheetah must be rather common, as I saw about fifteen cubs in Berbera of different ages, which a German collector had bought from the Somalis. I shot only one fully-grown Cheetah, which I found eating a sheep that it had killed." (*R. M. H.*)

11. HERPESTES OCHRACEUS Gray.

α. ♂. Jifa Medir, 5000 ft., 9 January, 1898.

β, γ. ♂ ♂. Jifa Medir, 5000 ft., 18 January, 1898.

"The Somali name for this animal is 'Saugor.' It is a fairly common animal and I have always seen it hunting by itself. It is very shy and hard to get near, and does not seem to show any curiosity. It is easily caught in cage-traps, as it will take a bait. I have one at present alive, but it is very wild and savage, and all my attempts to tame it have failed. The Somalis say that the 'Saugor' kills the Dik-Dik Antelope, but I could find no proof of it." (*R. M. H.*)

It is satisfactory to find that further material fully justifies the separation of this species from *H. gracilis*, as pointed out by the present writer in the *Ann. & Mag. Nat. Hist.* ser. 7, vol. i. 1898, p. 247.

12. CROSSARCHUS SOMALICUS Thos.

α, β. ♂ ♂. Jifa Medir, 5000 ft., 9 January, 1898.

"The Somalis call this animal a big Schuk-schuk, their name

for *Helogale atkinsoni*. I saw only one pack of them. They came out of the rocky hills to hunt on the plains for locusts and beetles, on which they seem to live chiefly, judging by their droppings, which were very plentiful on the rocks." (*R. M. H.*)

It is interesting to receive further specimens of this very distinct species, described by Mr. Oldfield Thomas (*Ann. & Mag. Nat. Hist.* ser. 6, vol. xv. 1895, p. 531) from two individuals collected by Mr. Gillett at Sunerdorler on the Webi Shebeli. The present specimens are both more richly coloured on the back, the bands being more clearly defined, while one of them has far more red colouring, somewhat obliterating the dark bands.

Mr. Harwood tells me that one evening, while kneeling down setting traps, a number of these animals came along, evidently making for the hills from the plains where they had been feeding during the day. The noise made by them very much resembled the cackling of a flock of Guinea-fowl, and on shooting one he was surprised to find that instead of a bird he had killed a large Mongoose.

13. HELOGALE ATKINSONI Thos.

α. ♀. Hargeisa, 3500 ft., 14 November.

β, γ. ♀ ♀. Jifa Uri, 5000 ft., 22 January.

"The first pack of these animals I saw near Hargeisa. They were crossing the watercourse and looked like birds running, as they had all their hairs on end. There were about fifteen in the pack and they took refuge in a disused termites' mound. I set traps, but was never able to catch any, as they did not seem to take any bait. They are very curious little animals, and if not frightened will sit up on the leaves of an aloe or rock and scold at one, giving a curious shuck! at the end of each scold. The Somalis call them 'Shuck-shuck.' They seem to live on locusts and other insects, judging by their droppings. One evening I met a pack on their way home from the plains; they ran at first into a solitary heap of stones, but kept running out and scolding, though I was only about ten yards from them. There were several Hyraxes on the same heap of stones, which did not take any notice of them. They seem to have very good sight, and keep a sharp look-out for birds of prey, running to cover as soon as one appears. I had the good fortune to capture a young Helogale. He had lost his mother and was squeaking like a young bird. He was no larger than a mouse, and yet very tame, and made a delightful pet. His curiosity was insatiable, as he would try and get into everything, and pull everything out of drawers and boxes. His note, when pleased, was like the chirp of a bird and always sounded some distance away. I brought him safely to England, but he was killed by a dog." (*R. M. H.*)

14. HYÆNA CROCUTA Erxleb.

"Common throughout Somaliland." (*R. M. H.*)

15. *HYÆNA STRIATA* Zimm.

"Not so common as the last species." (*R. M. H.*)

16. *CANIS MESOMELAS* Schreb.

"Jackals were everywhere very common." (*R. M. H.*)

More than a dozen skins were brought home, all belonging to this species.

17. *MELLIVORA RATEL* Sparrm.

"Only one or two seen." (*R. M. H.*)

18. *XERUS RUTILUS* Cretzschm.

α. ♀. Mandeira, 3500 ft., 9 Nov., 1897.

β. ♂. Harragagora, 3500 ft., 16 Nov., 1897.

"This Squirrel is very common all along the watercourses. They live in holes in the ground among the roots of a bush. They seem very susceptible to cold, as they never come out of the holes till the sun is well up. I kept several alive; their favourite food was the seeds of the aloë. They all got very tame, but eventually succumbed to the cold weather at night." (*R. M. H.*)

In a list of mammals collected in Somaliland by Mr. C. V. A. Peel (*Ann. & Mag. Nat. Hist. ser. 7, vol. i. 1898, p. 249*), this animal was referred to under the name of *X. dabagala* Heugl., but there can be no doubt that Heuglin simply renamed the species described by Cretzschmar, as the localities from which the specimens were obtained are almost identical, and all doubt is set aside by comparison of the figures given by these two writers.

This Squirrel has had the distinction of being once more given a coloured plate under a new name, *X. flavus* M.-Edw., by Huet (*Nouv. Arch. du Mus. 2^e sér. iii. pl. 6. fig. 2*). As pointed out by M. de Pousargues (*Ann. Sc. Nat., Zool. 1896, p. 337*), the subject of this figure did not come from Gaboon as originally stated, but from Somaliland, so that it is unquestionably identical with *X. rutilus* Cretzschm.

There is in Abyssinia another closely allied but very distinct species of Ground-Squirrel, which has been confused with this species, viz. *X. brachyotus* Hempr. & Ehr. *Symb. Phys. t. ix.*

The British Museum possesses several specimens obtained by Dr. W. T. Blanford, and referred to in his *Geol. & Zool. Abyss.* p. 278 (1870) under the heading of *X. rutilus*, with the remark that the colour does not agree with Cretzschmar's figure: moreover the original labels on the specimens further show that the identification was made with great doubt.

Hemprich and Ehrenberg give a very good coloured figure of this Squirrel, but it should not have been placed in a tree. M. Huet (*t. c. p. 139, pl. 6. fig. 1*) has also given a coloured figure of this Squirrel under the name *X. fuscus*; there can be no question of this being identical with *X. brachyotus*, as a comparison of the figures will show.

19. *GERBILLUS (TATERA) PHILLIPSI* de Wint.

♀. Jefa Medir, 5000 ft., 31 Dec.

♀. Jefa Medir, 5000 ft., 9 Jan.

♀. Ujawaji, 5000 ft., 25 Jan.

This Gerbille was described by the present writer (*Ann. & Mag. Nat. Hist.* ser. 7, vol. i. 1898, p. 253).

20. *ARVICANTHIS NEUMANNI* Matschie.

♀. Harragagora, 3500 ft., 16 Nov., 1897.

21. *TACHYORYCTES SPLENDENS* Rüpp.

α-γ. ♀ ♀ ♀. Ujawaji, 14 December, 1897.

δ. ♀. " " (in alc.).

"I saw the workings of this animal only on the open plains west of Ujawaji, where there had recently been some rain and the grass was green. The only way to get them was to clear away the mounds and open the hole and shoot the animal when it tried to close the hole. It almost invariably pushed some earth up to the mouth of the hole with its nose and then returned and shoved up more until the hole was closed. They feed on the roots of the grass. The Somali name is 'Frumfurt.'" (*R. M. H.*)

22. *DIPUS JACULUS* L.

♂. Arabsiyo, 4000 ft., 28 Nov., 1897.

"I found this specimen dead and rather decomposed, so it was difficult to make a good skin of it. The Somalis had told me of a wonderful animal they call a 'tik,' which had only one leg. When I showed them this animal they said it was a tik, but said nothing about its having two legs." (*R. M. H.*)

This is the first record of a Jerboa being found in Somaliland; the present specimen is not adult, but it does not seem to differ from the Egyptian species.

23. *PECTINATOR SPEKEI* Blyth.

♂. Mandeira, 3000 ft., 8 Nov., 1897.

"I saw this animal only in two places, once near Mandeira, and again near Eil Anod. They were in colonies, and lived among the rocks and were very tame. I had very little opportunity to observe them, as I was marching at the time." (*R. M. H.*)

The present specimen is by far the most perfect that has yet reached the Museum. It appears that the skin of this animal is peculiarly "tender," so much so that it is exceedingly difficult to prevent it being torn in the process of removing the fatty matter.

24. *PROCAVIA BRUCEI SOMALICA* Thos.

α. ♀. Aractais, 3000 ft., 12 Nov., 1897.

β. Jifa Uri, 5000 ft., 19 Dec., 1897.

"This animal was very numerous on Jifa Uri, Jifa Medir, and on all the isolated masses of rocks near them. They usually basked on the sunny sides of the rocks in the morning and evening, and were very tame then. They are exceedingly active in climbing

both steep rocks and trees, and I often saw them feeding on the leaves of small trees quite ten feet from the ground. When disturbed they descended the branches with surprising facility, considering their shape. They have a weird prolonged scream, which sounds as if it were produced by a much larger animal. The Somali name is 'Bona.' (R. M. H.)

25. *BUBALIS SWAYNEI* Sclat.

"There were large herds of these Hartebeests on Makani's and the surrounding country. They were fairly tame, and one could approach to within 200 yards without frightening them. There were many Midgans stalking them for the sake of their hides, which are valued for leather in Harar.

"The Somalis hunt them in the following manner:—Several Somalis surround a single male, and when he tries to break away he is headed; gradually they close in on him and he gets frightened and lies down, when they rush in and spear him. I was told this at first by a Somali, and afterwards I saw a hunt going on about three miles off, by the aid of a telescope, in which the Somalis killed the Hartebeest. I have also seen a slightly wounded Hartebeest do the same thing when headed several times." (R. M. H.)

26. *MADOQUA PHILLIPSI* Thos.

"This was very common." (R. M. H.)

27. *GAZELLA PELZELNI* Kohl.

"Fairly common on the maritime plain near Berbera.

"I never saw any of this Gazelle further than twenty miles from the coast." (R. M. H.)

28. *GAZELLA SPEKEI* Blyth.

"Was not very plentiful and was very shy and hard to approach." (R. M. H.)

29. *GAZELLA SEMMERRINGI* Cretzschm.

"Is very plentiful on what is called the Merar Prairie in the map of Somaliland, but what the Somalis call the Bund. This Gazelle goes in herds of about twenty or thirty, and sometimes in hundreds. There seemed to be many more males than females, and I have seen quite 300 males in a herd without a single female. They were very tame, as they are not hunted by the Midgans." (R. M. H.)

30. *LITHOCRANIUS WALLERI* Brooke.

"This Gazelle is found from within three miles of Berbera right through Western Somaliland where there are bushes. It is a shy animal, and as it has a habit of standing behind a bush and looking over it, it is hard to approach. It has sometimes a curious habit of standing quite upright with its head among the branches of the bush it is feeding on, and I have mistaken it at a distance for a Somali in a white robe, as its white colouring underneath shows up so conspicuously.

"Its flesh has a disagreeable musky flavour, owing perhaps to its habit of feeding on a species of *Solanum* which grows near old zerebas. I found in the stomach of one Gazelle several whole fruits of this *Solanum*, quite an inch and three quarters in diameter. The Somalis will not eat the flesh of this animal unless they are very hungry." (*R. M. H.*)

31. ORYX BEISA Rüpp.

"We saw tracks of this Antelope within twenty-five miles of Berbera, but they are very scarce until one gets south of Hargeisa. Between Hargeisa and Jig Jiga they were fairly numerous, and around the Subullo Hills there were many herds of about thirty females with single males.

"They were very shy in the plain, being hunted by Midgans with dogs and when brought to bay shot with poisoned arrows. The Midgans also stalk them, using camels or donkeys as stalking horses. On the heads of the latter they fix Oryx horns, so that it is almost impossible to tell the donkey from an Oryx at any distance.

"The Somali shield is made from the hide off the neck and shoulders of the male Oryx, which is about $\frac{3}{4}$ of an inch thick.

"Oryx when disturbed suddenly rush sideways with their faces towards the cause of the disturbance before they gallop off. This habit is evidently intended to receive the rush of some beast of prey. They are dangerous animals to approach when wounded, as even when lying down they can sweep their horns round very quickly and can even reach right over their rumps with them." (*R. M. H.*)

32. STREPSICEROS STREPSICEROS Pall.

"The greater Koodoo is getting rather scarce in Northern Somaliland, as the Midgans hunt it persistently on account of the value of its horns at the sea-coast, whence they are sent to Aden and sold.

"It lives on the rocky hills in the daytime, but comes down on to the flats in the evening to feed on the aloe bushes and the beans of the acacias. We saw a fair number of female Koodoos, but the males were very scarce, and once we saw a herd of seven females without a single young one.

"The male Koodoo is a magnificent-looking animal when seen standing upon a rock on the sky-line looking for the cause of some noise he has heard before retiring.

"In daytime they lie very close in the thick bushes until they think they have been seen, and then they go off with a tremendous crash through the bushes." (*R. M. H.*)

33. STREPSICEROS IMBERBIS Blyth.

"This beautiful Antelope is still fairly common in the country round the Goli range where there are plenty of aloes. We found them quite close to villages, lying hidden in the thick clumps of aloes, from which they would dash out when disturbed and hide in some other favourite retreat." (*R. M. H.*)

3. On Mammals collected by Mr. J. D. La Touche at Kuatun, N.W. Fokien, China. By OLDFIELD THOMAS.

[Received October 10, 1898.]

In the spring of this year Mr. J. D. La Touche, who had for some years interested himself in the birds and mammals of the vicinity, made a special collecting-trip to Kuatun, in the mountains of North-western Fokien, and obtained there a considerable number of small mammals. This collection he has been good enough to allow me to work out, and he has also permitted the British Museum to acquire a full selection of the specimens, besides presenting several valuable examples in spirit.

For some years, in conjunction with Mr. C. B. Rickett, also a generous donor to our National Museum, Mr. La Touche has had collectors at work at Kuatun, and many of the specimens so obtained have been presented to the Museum as they have come in. The first specimens received by us of *Typhlomys cinereus* and the type of *Mus latouchei* have been presented in this way.

The following observations on the situation and character of Kuatun are contributed by Mr. La Touche, who is also the author of the various notes in inverted commas appended to the different species.

The species, including two sent previously and not in the present collection, number 26, of which one species and one subspecies appear to need new names.

Mr. La Touche describes as follows the position and characteristics of Kuatun, the Chinese village where the collection was made:—

“Kuatun is a small hamlet, lost, as Père David says, among the mountains of N.W. Fokien, called in English maps the Bohea Mts. It is but a few miles from the Kiangsi border. The village had at the time of our stay a population of 54 people, 37 adults and 17 children. Nearly all are, I believe, descendants of emigrants from Kiangsi. The village is built on the slope of a steep mountain and is about 3500 ft. above sea-level, the mountain rising above it to a height of about 6500 ft. above sea-level. This mountain is as high as any in the district. The country is very thickly wooded in many parts, and the mountains have in many cases extensive tracts of grass-land near their summits. The top of Kuatun Mountain, which I would venture to call “Mount David,” after the discoverer of the locality as a collecting-ground, is covered with forest, consisting of dwarfed, moss-grown, deciduous trees, with an undergrowth of dwarf bamboos. The productions of the country, where cultivated, are tea¹ and bamboo. A little maize, a few sweet-potatoes, rough turnips and cabbages are also grown for local consumption. Everything else in the way of food has to be brought from a distance. The climate of these mountains is on the whole cold and damp.

¹ The highest tea-plantation of the district is on Mount David, alt. 5,500 ft.

In the winter snow and ice cover the mountains; the spring is rainy and very cold. Moderate heat prevails in summer, and the autumn is cool and fairly dry as in other parts of China. We were told that it rains in Kuatun for eight months in the year. This country is about as wild as any in S.E. China. Close to Kuatun whole mountain-slopes are still virgin forest, the steepness of the hills and difficulty of transporting the timber being the reasons for which deforestation is not carried on in the usual Chinese fashion. The native hunters that we employed while at Kuatun are excellent field-naturalists and hardy, energetic hunters, and in all their statements regarding the natural history of the district were perfectly truthful and straightforward. But they, as well as the villagers generally, are rough and unsympathetic, and their love of money is unbounded. Although Kuatun is an excellent collecting-ground, the country is by no means easy to work. The hills are very steep, the forests very thick and difficult walking, and cold, damp, want of nourishing food, and all the minor discomforts consequent on living in close proximity with Chinese will be experienced by any one venturing to explore these wild parts of S.E. China."

1. *MACACUS RHESUS* L.

"One of a party of three killed by a hunter. The natives told us that this species was the commoner of the two known at Kuatun. Monkeys are seldom seen in summer, but in autumn and winter they are often seen in the woods going about in bands."

2. *RHINOLOPHUS LUCTUS* Temm.

One specimen. 18/4/98.

This is the first record of the occurrence of *R. luctus* in China, but it is quite natural that so characteristic a Himalayan form should be found there.

3. *RHINOLOPHUS PEARSONI* Horsf.

One specimen. 16/4/98.

4. *VESPERTILIO MURINUS*¹ SUPERANS, subsp. n.

Six specimens.

Apparently exactly like the European *V. murinus* in colour and all other respects, but constantly larger, the forearm ranging from 4 to 9 mm. longer than in European examples.

Forearm of the type 50 mm.

Hab. Se-sa-lin, Ichang, Yang-tse-kiang.

Type. B. M. No. 97.4.21.1. Collected Oct. 1, 1896, and presented by Mr. F. W. Styan.

The first Chinese example of *V. murinus* received by the Museum was that presented by Mr. Styan, and now selected as the type. In spite of its markedly greater size it did not seem advisable to

¹ *Vesperugo discolor* auctorum.

give it a special name on a single specimen, but now that Mr. La Touche's collection contains six more examples of this large race, it is shown to be so constant as to deserve a subspecific name.

5. *PIPISTRELLUS SAVII PULVERATUS* Pet.

One specimen, presented in 1897.

6. *PIPISTRELLUS ABRAMUS* Temm.

One specimen, presented in 1897.

7. *SCOTOPHILUS ORNATUS* Bly.

One specimen, presented in 1897.

This also, like *Rhinolophus luctus*, is the first Chinese record of a Himalayan species.

8. *MURINA LEUCOGASTRA* M.-Edw.

One specimen. 5/98.

I quite fail to follow Dobson's reasons¹ for upsetting his previous perfectly correct adoption of *Murina* instead of *Harpiocephalus* for the name of the present genus. Both by "page priority" and the opinion of the "first reviser" (Dobson in his earlier work) *Murina* should be adopted for the genus, whether *Harpiocephalus* is subgenerically synonymous with it or not.

9. *CROCIDURA* sp. inc.

Six young specimens, not determinable.

A shrew of the *C. russula* group, from Ching Feng Ling, is also included in the collection.

"Caught in the stony bed of a dried-up torrent."

10. *TALPA WOGURA* Temm.

Four skins, and two specimens in spirit.

"Tolerably common."

11. *FELIS DOMINICANORUM* La Touche².

The type specimen of this species was until recently living in the Society's Menagerie. It was obtained at Kuatun, so that a passing reference may be made to it here.

12. *MUSTELA FLAVIGULA* Bodd.

One specimen.

"Shot in the forest."

13. *SCIURUS MACCLELLANDII SWINHOEI* M.-Edw.

Two specimens. Several others previously sent.

"An abundant species. Nests of this or the next one were often met with. These squirrels were breeding during our stay, and many young ones, too small to rear, were brought to us."

¹ Mon. Asiatic Chiroptera, p. 150 (footnote) (1876).

² P. Z. S. 1898, p. 1, pl. i. The animal died in March last, and the specimen is now in the British Museum.—Edw.

14. FUNAMBULUS PERNYI M.-Edw.

Five specimens.

Several examples of this well-marked species have also been presented to the Museum by Messrs. La Touche & Rickett in previous consignments.

“Common in the forests at 3000–4000 feet altitude.”

15. TYPHLOMYS CINEREUS M.-Edw.

Six skins and a male in spirit.

Mr. La Touche had already presented the British Museum with three skins of this most interesting little animal, and it was by the help of these that, when working out the classification of the Rodents, I was enabled to show its relationship to the South Indian *Platacanthomys*.

In the same paper¹ was recorded the important fact that the latter genus, like the true *Glirinæ*, possesses no cæcum, and it has therefore been with much interest that I have examined the intestines of Mr. La Touche's spirit-specimen of *Typhlomys*. Here I find that, unlike its ally, a cæcum is present, although it is only about an inch in length. *Typhlomys* is, therefore, even more distinctly intermediate between the *Gliridæ* and the *Muridæ* than had been supposed.

“I procured 8 specimens of this rare mouse. I believe they were all caught in the mountains some hundred feet above the village, say at 4000 feet.”

16. MUS LATOCHEI Thos.

Two specimens.

This fine rat was described in 1897² on one of Mr. La Touche's Kuatun specimens. Like so many other animals in this region it seems to have been first obtained by Père David, as I find I have notes on a specimen in the Paris Museum received there in 1874.

“*Mus latouchei* is a forest rat, and is uncommon, at least in the spring. Once, when walking in the forest, a native hunter showed me a run and burrow of this rat. It was in the bank by the side of the path. We procured only one specimen during our stay, but another had been collected for me during the winter.”

17. MUS HUMILIATUS M.-Edw.

One from Kuatun 27/4/98, another from Tung Chin, and a third from Swatow.

This animal is closely allied to *M. decumanus*, and is not impossibly the original wild stock of that ubiquitous pest.

“House-rat at Kuatun, I believe.”

18. MUS BATUS FLAVIPECTUS M.-Edw.

Three specimens.

Milne-Edwards's *Mus flavipectus* is clearly a member of the *Mus*

¹ P. Z. S. 1896, p. 1016, footnote.

² Ann. & Mag. N. H. (6) xx. p. 113.

rattus group, and is closely allied to the Himalayan *M. r. nitidus* Hodgs. For the present it may be conveniently referred to as a subspecies of *M. rattus*, just as has been done with the Indian and Malayan members of the group.

“House-rat at Kuatun.”

19. *MUS EDWARDSI* Thos.

Two specimens.

Originally described ¹ on one of Père David's specimens.

“This is, I believe, a forest-rat. It is not commonly trapped, at least in the spring. Only two specimens were taken during our stay.”

20. *MUS CONFUCIANUS* M.-Edw.

Fifty specimens.

This must be one of the most common of the rats of this part of China, as every collection contains a number of examples of it. It appears to be a smaller relative of the Formosan *Mus coxingi*, and is also closely allied to the Himalayan *M. jerdoni* Blyth. It is indeed not impossible that it may be found to intergrade into the latter.

Of all Muridæ the rats of this group seem to be the most variable both in colour and size, so that it is very difficult to come to a satisfactory conclusion about their interrelationships. The present series shows the usual wonderful variability, many shades of red, yellow, and grey, and all degrees of spininess being found among them. Speaking generally they tend to fall into two groups, the one greyish, with white-tipped tail and comparatively narrow skull, the other reddish with the tail only white below, and the skull comparatively broad; but the two groups are not yet fully differentiated, as intermediate individuals in regard to each of the differential characters are to be found among the series. In actual size, like *M. coxingi*, they do not seem to vary quite so much as the Bornean examples of the group, to which reference was made in a paper on the Muridæ of that island ².

“Very abundant everywhere; they differ much among themselves.”

21. *MUS CHEVRIERI* M.-Edw.

Seventeen specimens.

This is the Chinese representative of the common Long-tailed Field-mouse, *Mus sylvaticus*.

Judging by the present series, it is rather more constant in colour than its European relative *M. sylvaticus*, and its change from the grey phase to the rufous is carried out more abruptly than in Europe, so that the intermediate specimens so commonly caught here do not occur there, while on the other hand

¹ P. Z. S. 1882, p. 587.

² Ann. & Mag. N. H. (6) xiv. p. 452 (1894).

specimens may be obtained partly rufous and partly grey, a stage that I have never seen in European series.

“The common field-mouse of the Kuatun district.”

22. *MUS HARTI*, sp. n.

Adult and young.

Allied to *Mus agrarius*, of which it is the Chinese representative. Size and general appearance very much as in *M. chevrieri*. Colour above dull grizzled rufous, not or but little brightening posteriorly; under surface dull white, the slaty bases of the hairs showing through; line of demarcation on sides fairly sharply defined. Ears very short, well-haired, blackish, a few minute silvery hairs intermixed with the black. Dorsal line very indistinct, scarcely perceptible, very different to the strong and sharply-defined line of *M. agrarius*. Upper surface of hands and feet white. Tail about as long as the head and body, thin, almost naked, its scales dark throughout, its minute hairs dark above and inconspicuously white below.

Skull and dentition not appreciably different from those of *M. agrarius*.

Dimensions of the type, in skin:—

Head and body (apparently stretched), 99 mm.; tail, 92; hind-foot (wet), 21·5.

Skull: greatest length, 26; basilar length, 21; greatest breadth, 13·8; length of nasals, 9·6; interorbital breadth, 4·5; palate, length from henselion, 12; diastema, 7·4; palatal foramina, 5 × 2; length of upper molar series, 3·9.

Type. B. M., No. 98.11.1.18, collected May 4th, 1898, by J. D. La Touche.

Besides these two specimens from Kuatun the Museum contains a skin in spirit from Kiu-kiang on the Yang-tse, collected by Mr. F. W. Styan in 1888, and one from Baksa, Formosa, obtained by Mr. P. A. Holst in 1893.

On the other hand a specimen from Mantchuria, although separable subspecifically¹, shows, as might be expected, a much closer resemblance to the strongly rufous and black-lined *Mus agrarius* than to the South Chinese *M. harti*.

At Mr. La Touche's suggestion, I have named this species in honour of Sir Robert Hart, the well-known Inspector-General of

¹ *MUS AGRARIUS MANTCHURICUS*, subsp. n.

Similar to *M. a. typicus* in all essential respects, but slightly larger, and of a much brighter, richer, and more uniform rufous above and on the sides, the grey tone present in *typicus* being quite lost in the rich rufous of the Eastern form.

Dimensions of the type, in skin:—

Head and body (apparently stretched), 116 mm.; tail, 78; hind foot (wet), 19; ear (wet), 14.

Skull: greatest length, 27; length of upper molar series, 4·1.

Hab. Mantchuria.

Type. B. M., No. 83.2.24.1. Collected by Dr. Janskowski, and presented by the Branicki Museum, Warsaw.

Chinese Customs, to whose kindness he has been indebted for many facilities in carrying on his scientific work.

23. *MUS PYGMÆUS* M.-Edw.

Three skins and five specimens in spirit.

This is the Eastern representative of the European Harvest-mouse. Mr. La Touche's specimens, as also an example from Shanghai sent home by Consul Swinhoe, have tails somewhat longer than Prof. Milne-Edwards gives in his description of *Mus pygmæus*. The same author gives the hind feet as 18 mm. in length. In my notes on the type specimen in the Paris Museum, however, I find that the tail is said to be "doubtfully perfect," and the hind feet are recorded as 13.9 mm., so no doubt 18 is a misprint for 14, a length which quite agrees with what is found in the Kuatun specimens.

24. *MICROTUS MELANOGASTER* M.-Edw.

Ten specimens.

"This appears to be common enough, though I saw only one live specimen, which my little dog routed out of its run in the brushwood near the path leading up to the village."

25. *RHIZOMYS SINENSIS* Gray.

This fine Bamboo-rat seems to be common, as a good number of specimens have been sent home at various times by Messrs. La Touche & Rickett.

"Found in the bamboo plantations, about 3000 feet. Young ones were brought to us in April, and we bought three very young ones alive, but they died after a few days' captivity."

26. *LEPUS SINENSIS* Gray.

Two specimens, presented in 1896.

4. A Revision of the Genera and Species of Fishes of the Family *Mormyridæ*. By G. A. BOULENGER, F.R.S.

[Received November 3, 1898.]

(Plate LI.)

The numerous additions to the freshwater Fish-Fauna of Africa, which it has lately been my good fortune to describe, have necessitated much revision of the work of my predecessors in this department. With no group was this more necessary than with the *Mormyridæ*.

Although a considerable number of genera have been proposed and defined in more or less satisfactory manner by Johannes Müller, Marcusen, Gill, and Bleeker, the tendency has of late been to revert to the view of Valenciennes and to unite all the species under the head *Mormyrus*, with the exception of *Gymnarchus*,

which latter genus has even been raised, without sufficient justification, to family rank. Although naturally adverse to the multiplication of genera, I cannot hesitate, in this case, to restore most of those previously proposed by the above-mentioned authors, and even to add to their number, as I am doing in a publication dealing with the Congo species, which will appear simultaneously with the reading of this paper. I believe that I have succeeded in giving definitions of the genera clear and precise enough to greatly facilitate the study of this highly remarkable family. I can confidently affirm that the genera here admitted are fully equivalent to, and at least as clearly defined as, those universally admitted in the families *Clupeidae*, *Cyprinidae*, and *Characinidae*. The difference between *Mormyrus* and *Hyperopisus*, for instance, is strictly comparable to that between *Albula* and *Bathyrhissa* among the Clupeines; yet, in the same classification (Günther's 'Study of Fishes,' 1880), the two former types are not allowed even the rank of genera, while the two latter are unnecessarily referred to distinct families.

The union of the genus *Mormyrops* with *Mormyrus* can have been suggested only in ignorance of the marked differences in the vertebral column to which attention was first drawn by Hyrtl. The vertebral column shows a greater degree of specialization in the latter than in the former, the posterior præcaudal vertebra being devoid of those remarkable hæmal bridges to the extremity of which the corresponding ribs are attached, a morphological difference the importance of which would alone justify generic separation. Moreover, as also pointed out by Hyrtl, and since confirmed by Peters and by Fritsch, the *Mormyrops* are true carnivores, like *Gymnarchus*, while the other Mormyrs feed exclusively or mainly on vegetable matter and minute animals.

In the more generalized character of the vertebral column, *Mormyrops* agrees with *Gymnarchus*, and we may regard the latter as an ultra-specialized, anguilliform modification of the former, the other Mormyroids being also modified, but in other directions, from such a type. This conception is supported by a consideration of other characters. Thus I represent to myself the hypothetical primitive type of Mormyr as elongate like an *Albula* (1), with the dorsal (2) and anal (3) fins elongate (basally), large ventral and caudal fins (4), a fairly large mouth (5), and with the præmaxillary (6), parasphenoid (7), and glossohyal (8) bones armed with several rows of small conical teeth. As many as 7 out of these 8 points (1, 2, 3, 4, 5, 7, 8) have been retained by some of the *Mormyrops*, no. 2 in common with *Gymnarchus*; no. 6 has been preserved in one genus only, *Myomyrus*; while it is interesting to observe the interchange in nos. 2 and 3 exhibited by *Mormyrus* and *Hyperopisus*. It is also of importance, as bearing on this question, to note the reduction in the size of the caudal fin that takes place within the genus *Mormyrops*, a feature which may even lead us to speculate on the possible discovery of forms that would fill the gap now existing between the Mormyrs with well-developed homocercal tail and the *Gymnarchus*, in which,

concurrently with the loss of the ventral and anal fins, the caudal fin has been suppressed, the tail terminating in a free, irregularly segmented, calcified notochordal filament.

Although I have not at present sufficient osteological material at my command to undertake a thorough study of the skeletons from a systematic point of view, such characters as I have been able to observe, on the skeletons of one or two species of each of the genera and with the aid of the Röntgen rays, through the kind assistance of Messrs. J. H. Gardiner and J. Green, show that the generic definitions will be materially strengthened when the number of vertebræ can be recorded; this I have therefore now attempted, perhaps somewhat prematurely, considering the comparatively small number of species examined in that respect. In most of the genera, the vertebral column must be divided into three principal regions:—1. The præcaudal proper; 2. An intermediate region with strongly developed ribs attached to closed hæmal arches, under which the posterior portion of the air-bladder extends; 3. The caudal proper. The second region does not exist in *Mormyrops*, *Isichthys*, *Stomatorhinus*, and *Gymnarchus*. I have ascertained the number of vertebræ in 15 species belonging to the 11 genera defined below:—

<i>Mormyrops anguilloides</i>	24 + 37 = 61.
„ <i>zanclostris</i>	22 + 34 = 56.
<i>Petrocephalus bane</i>	9 + 4 + 29 = 42.
<i>Isichthys henryi</i>	26 + 38 = 64.
<i>Marcusenius discorhynchus</i>	9 + 5 + 27 = 41.
„ <i>plagiostoma</i>	12 + 4 + 30 = 46.
„ <i>wilverthi</i>	12 + 5 + 27 = 44.
<i>Stomatorhinus microps</i>	14 + 25 = 39.
<i>Myomyrus macrodon</i>	14 + 4 + 32 = 50.
<i>Gnathonemus tamandua</i>	12 + 6 + 27 = 45.
„ <i>rhynchophorus</i>	13 + 4 + 30 = 47.
<i>Mormyrus kannume</i>	13 + 7 + 30 = 50.
<i>Hyperopisus bebe</i>	15 + 6 + 38 = 59.
<i>Genyomyrus donnyi</i>	13 + 7 + 29 = 49.
<i>Gymnarchus niloticus</i>	45 + 75 = 120.

That the numbers vary within certain limits need hardly be added, but so far little has been done in this line of investigation, except by Hyrtl, who has supplied information on the following species:—

<i>Mormyrops anguilloides</i>	23 + 36 = 59.
„ <i>deliciosus</i> (<i>zambanenje</i>) ..	23 + 39 = 62.
<i>Petrocephalus bane</i>	9 + 6 + 27 = 42.
<i>Gnathonemus cyprinoides</i>	13 + 8 + 27 = 48.
<i>Mormyrus caschive</i>	12 + 7 + 30 = 49.
„ <i>kannume</i>	13 + 10 + 31 = 54.
<i>Hyperopisus bebe</i>	16 + 4 + 35 = 55.
<i>Gymnarchus niloticus</i>	47 + 67 = 114.

These results have been utilized in drawing up the generic diagnoses.

The sciagraph of *Gnathonemus rhynchophorus*, which is appended to this paper, shows well the three regions into which the vertebral column may be divided, and also the so-called Gemmingerian bones running parallel to the axis, dorsally to the neural spines, and ventrally to the hæmal spines in that portion of the caudal region which is occupied by the electric organ. These curious ossifications, discovered by Gemminger, have been shown by Hyrtl to be a universal character of the *Mormyridæ*, though not directly related to the electric organ.

By a curious oversight, the *Mormyridæ* have been referred by Jordan and Evermann (Fish. N. Amer. i. 1896, p. 114) as an Order (*Scyphophori*, Cope) to the group *Ostariophysii*, Sagemehl, embracing the *Siluridæ*, *Gymnotidæ*, *Cyprinidæ*, and *Characinidæ*, which agree in the co-ossification of the anterior vertebræ and the connection of the air-bladder with the ear through the Weberian ossicles. Such a character is well known not to exist in the Mormyrs, which would fall under their definition of the order *Isospondyli*, Cope, but for the absence of the symplectic bone. The nearest allies of the Mormyrs, giving an idea of the more generalized type from which they may have been derived, appear to me to be found in the *Albulidæ*, as suggested by Valenciennes in 1846. These possible ancestors of the Mormyrs belong to the most generalized forms of Clupeines, *i. e.* those most affine to the Amioid Ganoids, having retained the muscular *conus arteriosus* with two rows of valves, as first shown by Stannius in 1846; whilst the nearly related lowly Clupeines, the *Chirocentridæ* and the *Elopidae*, are unique in the retention of two other 'Ganoid' characters, *viz.*, the spiral fold of the intestine in the former, and the gular plate in the latter.

The family *Mormyridæ* may be defined as Isospondylous Physostomes with coalesced præmaxillary bones, parietals separating the frontals from the supraoccipital¹, with a cavity on each side of the parietals leading into the interior of the skull and covered with a thin lid-like bone, with the subopercular small, if present, and without symplectic bone². Opercular bones concealed under the skin; gill-clefts narrow.

These Fishes, of which 73 species are described in this paper, are restricted to the fresh waters of Africa, from the Nile and Senegal to Angola, Lake Ngami, and the Zambesi. The Congo has yielded more species than any other river, *viz.* 34.

A great deal has been published on their anatomy and physiology; the principal contributions are recorded below. Unfortunately nothing as yet has been observed on their breeding-habits and development, and we do not know whether the young pass through

¹ Günther's statement (Cat. vi. p. 214) "Single parietal bone" can only be accounted for by a mis-rendering of Valenciennes's description (xix. p. 234): "En arrière des frontaux nous voyons deux petits pariétaux se toucher, comme dans les carpes et comme dans les aloses, pour former une espèce de plaque impaire sur la voûte du crâne."

² In the two latter points they agree with the Siluroids, to which they bear, however, no relationship.

a larval stage, analogous to that of the *Murcenidæ*, as ascertained by C. H. Gilbert to be normal in *Albula*, which, as stated above, may be considered as the nearest ally of the *Mormyridæ*.

Principal Anatomical and Physiological References.

- HEUSINGER, C. F. Bemerkungen über das Gehörwerkzeug des *Mormyrus cyprinoides*, . . . &c. Arch. f. Anat. u. Physiol. 1826, pp. 324-327, pl. iv.
- ERDL, M. P. Ueber das Gehirn der Fischgattung *Mormyrus*. Münch. Gelehrt. Anz. xxiii. 1846, pp. 403-407.
- Beschreibung des Skeletes des *Gymnarchus niloticus*. Abh. Bayer. Akad. v. 1847, pp. 209-252, pl. v.
- GEMMINGER, M. Elektrisches Organ von *Mormyrus*, &c. Dissert. Inaug., München, 1847.
- KÖLLIKER, A. Ueber die elektrischen Organe des *Mormyrus longipinnis*, Rüpp. Ber. zootom. Anst. Würzburg, 1849, pp. 9-13.
- FÖRG, —. Remarques sur l'appareil pulmonaire du *Gymnarchus niloticus*. Ann. Sci. Nat. (2) xx. 1853, pp. 151-154.
- DUVERNOY, G. L. Note additionnelle. T. c. pp. 154-162, pl. v.
- ECKER, A. Anatomische Beschreibung des Gehirns vom Karpfenartigen Nil-Hecht, *Mormyrus cyprinoides*. Leipzig: 1854, 4to, 12 pp., 1 pl.
- FISCHER, L. Ueber das Gehörorgan der Fischgattung *Mormyrus*. Inauguraldissert., Freiburg i. Br. 1854, 4to, 36 pp., 1 pl.
- HYRTL, J. Anatomische Mittheilungen über *Mormyrus* und *Gymnarchus*. Denkschr. Akad. Wien, xii. 1856, pp. 1-22, pls. i.-vi.
- MARCUSEN, J. Die Familie der Mormyriden. Eine anatomisch-zoologische Abhandlung. Mém. Acad. St. Pétersb. (7) vii. No. 4, 1864, 162 pp., 5 pls.
- BABUCHIN, A. Beobachtungen und Versuche am Zitterwelse und *Mormyrus*. Arch. f. Physiol. 1877, pp. 250-274, pl. vi.
- SANDERS, A. Contributions to the Anatomy of the Central Nervous System in Vertebrate Animals. I. On the Brain of the *Mormyridæ*. Phil. Trans. clxxiii. 1882, pp. 927-959, pls. lix.-lxxiii.
- FRITSCH, G. Zur Organisation des *Gymnarchus niloticus*. Sitzb. Akad. Berl. 1885, pp. 119-129, figs.
- Weitere Beiträge zur Kenntniss der schwach elektrischen Fische. Op. cit. 1891, pp. 439-460, figs.
- DU BOIS REYMOND, E. Vorläufiger Bericht über die von Prof. Gustav Fritsch angelegten neuen Untersuchungen an elektrischen Fischen. T. c. pp. 111-114.
- FRITSCH, G. On the Origin of the Electric Nerves in the Torpedo, *Gymnotus*, *Mormyrus*, and *Malapterurus*. Rep. Brit. Assoc. 1892, pp. 757 & 758 (1893).
- OGNEFF, J. Einige Bemerkungen über den Bau des schwach elektrischen Organs bei den Mormyriden. Zeitschr. wiss. Zool. lxiv. 1898, pp. 565-595, pl. xviii.

Synopsis of the Genera.

- I. Ventral, anal, and caudal fins present; teeth on the parasphenoid and on the tongue.
- A. A single series of teeth in each jaw.
1. 12 or more teeth in each jaw.
- Mouth terminal or subinferior, anterior to the vertical of the eyes; body elongate; anal longer than dorsal; nostrils moderately far apart, remote from the eye 1. *Mormyrops* J. Müll.
- Mouth inferior, below the eye; body short; nostrils close together, close to the eye..... 2. *Petrocephalus* Marc.
2. No more than 10 teeth in each jaw.
- a. Palatal and lingual teeth minute, conical.
- a. Mouth inferior or subinferior, below the level of the eyes.
- * Body much elongate, eel-like; ventrals nearer anal than pectorals 3. *Isichthys* Gill.
- ** Body short or moderately elongate; ventrals equally distant from pectorals and from anal, or nearer the former.
- Teeth small, truncate or notched; posterior nostril remote from the mouth 4. *Marcusevius* Gill.
- Teeth small, bicuspid; posterior (lower) nostril close to the mouth 5. *Stomatorhinus* Blgr.
- Upper teeth small, conical; mandibular teeth compressed, median pair very large, incisor-like; nostrils close together 6. *Myomyrus* Blgr.
- β. Mouth terminal.
- Dorsal and anal not very unequal in length 7. *Gnathonemus* Gill.
- Dorsal at least $2\frac{2}{3}$ as long as anal 8. *Mormyrus* L.
- b. Palate and tongue with a pavement of large spheroid teeth; dorsal short, anal very long 9. *Hyperopisus* Gill.
- B. Teeth in the jaws disposed in several rows forming villiform bands; dorsal and anal nearly equally developed 10. *Genyomyrus* Blgr.
- II. Ventral, anal, and caudal fins absent; body eel-like; palate and tongue toothless 11. *Gymnarchus* Cuv.

1. MORMYROPS.

Mormyrus, part., Linn. Syst. Nat. i. p. 522 (1766).

Mormyrops, part., J. Müller, Arch. f. Nat. 1843, p. 324; Günth. Cat. vi. p. 223 (1866).

Mormyrops, Gill, Proc. Ac. Philad. 1862, p. 139; Peters, Reise n. Mossamb. iv. p. 88 (1868); Bouleng. Ann. Mus. Congo, Zool. i. 1898, p. 2.

Oxymormyrus, Bleek. Versl. Ak. Amsterd. (2) viii. 1874, p. 367.

Teeth in the jaws conical, truncate, or notched, forming a single complete series on the entire edge of both jaws (12-36 in each); minute conical teeth on the parasphenoid and on the tongue;

mouth terminal or subinferior. Nostrils moderately far apart, remote from the eye. Body more or less elongate; ventrals equally distant from pectorals and from anal, or nearer the former. Anal longer than dorsal. Vertebrae 56-62 (22-24 + 34-39).

Synopsis of the Species.

- I. Caudal peduncle 2 to $2\frac{1}{2}$ as long as deep, $\frac{1}{3}$ to $\frac{1}{2}$ length of head.
- A. 20-36 teeth in each jaw; head at least nearly twice as long as deep; lat. l. 85-96.
- D. 21-27; A. 41-51; 16-18 scales round caudal peduncle; depth of body 5-6 times in total length; head nearly twice as long as deep 1. *deliciosus* Leach.
- D. 26-28; A. 39-42; 20 scales round caudal peduncle; depth of body 5- $6\frac{1}{2}$ times in total length; head nearly twice as long as deep 2. *anguilloides* L.
- D. 26; A. 39; depth of body 7 times in total length; head more than twice as long as deep ... 3. *longiceps* Gthr.
- D. 26; A. 43; depth of body $7\frac{2}{3}$ times in total length; head nearly twice as long as deep 4. *breviceps* Sldr.
- B. 12-16 teeth in each jaw.
1. Dorsal 19-21.
- Snout much produced, tubiform, straight; head $2\frac{1}{2}$ - $2\frac{3}{4}$ as long as deep. Anal 36-39; lat. l. 70-74... 5. *zanclirostris* Gthr.
- Snout short; head twice as long as deep. Anal 35-37; lat. l. 80-93 6. *engystoma* Blgr.
2. Dorsal 30; snout short; head not twice as long as deep.
- A. 40, originating a little in advance of dorsal, and slightly nearer head than base of caudal ... 7. *masuianus* Blgr.
- A. 47, originating considerably in advance of dorsal, and at nearly equal distance from end of snout and base of caudal 8. *sirenoides* Blgr.
- II. Caudal peduncle not longer than deep, $\frac{1}{3}$ - $\frac{1}{2}$ length of head; 12-16 teeth in each jaw.
- D. 29; A. 48; lat. l. 80; depth of body 6 times in total length 9. *lineolatus* Blgr.
- D. 34-37; A. 50-59; lat. l. 100-105; depth of body $5\frac{1}{2}$ - $6\frac{1}{2}$ times in total length 10. *marie* Schilth.
- D. 45; A. 70; lat. l. 102; depth of body a little more than 6 times in total length 11. *microstoma* Blgr.
- D. 43; A. 63; lat. l. 95; depth of body $8\frac{1}{2}$ times in total length 12. *attenuatus* Blgr.

1. MORMYRUPS DELICIOSUS.

Oxyrhynchus deliciosus, Leach, in Tuckey, Exped. R. Zaire, p. 410 (1818).

Mormyrus tuckeyi, Cuv. & Val. xix. p. 263 (1846).

Mormyrus zambanenje, Peters, Mon. Berl. Ac. 1852, p. 275
Günth. Proc. Zool. Soc. 1896, p. 224.

Mormyrops tuckeyi, Marcusen, Bull. Ac. St. Pétersb. xii. 1854, p. 14.

Mormyrops deliciosus, Günth. Cat. vi. p. 224 (1866); Steind. Sitzb. Ak. Wien, lxi. i. 1870, p. 555, pl. v. fig. 1; Perugia, Ann.

Mus. Genova, (2) x. 1892, p. 976; Steind. Notes Leyd. Mus. xvi. 1894, p. 65.

Mormyrops zambanenje, Günth. l. c.

Mormyrus (Mormyrops) zambanenje, Peters, Reise n. Mossamb. iv. p. 88, pl. xv. fig. (1868).

Mormyrus (Mormyrops) swanenburgi, Schilthuis, Tijds. Nederl. Dierk. Ver. (2) iii. 1891, p. 91.

Depth of body 5 to 6 times in total length, length of head $3\frac{1}{2}$ to $4\frac{1}{4}$. Head nearly twice as long as deep, upper profile slightly concave; snout rounded; jaws equal; width of mouth nearly equal to length of snout; teeth truncate or conical in the adult, more or less distinctly notched in the young, 24 to 35 in each jaw; eye small, situated in the anterior third of the head, its diameter 2 (young) to 4 times in length of snout, 2 to 3 times in interorbital width. Dorsal 21–27, $\frac{1}{2}$ length of anal or a little more, originating 2 to $2\frac{1}{2}$ as far from the end of the snout as from the base of the caudal. Anal 41–51, originating considerably in advance of dorsal (its 12th to 16th ray corresponding to the first dorsal ray), and a little nearer head than root of caudal. Pectoral $\frac{2}{5}$ to $\frac{1}{2}$ length of head, ventral $\frac{1}{4}$ to $\frac{1}{3}$. Caudal rather small, densely scaled, with rounded lobes. Caudal peduncle twice as long as deep, $\frac{1}{3}$ to $\frac{2}{5}$ length of head. 85–96 scales in the lateral line, $\frac{15-17}{20-22}$ in a transverse line on the body, 23–26 in a transverse line between dorsal and anal, 16 or 18 round caudal peduncle. Olive above, silvery beneath.

Total length 1230 millim.

Senegal, Congo, Zambezi, L. Nyassa, Webi Shebeli and Juba.

2. MORMYRIPS ANGUILLOIDES.

Mormyrus anguilloides, Linn. Mus. Ad. Frid. ii. p. 110 (1764), and S. N. i. p. 522 (1766); Geoffr. Descr. Égypte, Poiss. p. 274, pl. vii. fig. 2 (1829); Cuv. & Val. xix. p. 258 (1846); Marcusen, Mém. Ac. St. Pétersb. (7) vii. 1864, no. 4, p. 132.

Mormyrus dendera, Lacép. Hist. Poiss. v. p. 621 (1803).

Mormyrops anguilloides, Marcusen, Bull. Ac. St. Pétersb. xii. 1854, p. 14; Günth. Cat. vi. p. 223 (1866).

Marcusenius anguilloides, Gill, Proc. Ac. Philad. 1862, p. 444.

Depth of body 5 to $6\frac{1}{2}$ times in total length, length of head 4. Head nearly twice as long as deep, upper profile slightly concave; snout rounded, the upper jaw a little longer than the lower; width of mouth less than length of snout; teeth more or less distinctly notched, 22 or 24 in each jaw; eye small, situated in the anterior third of the head, its diameter $2\frac{1}{2}$ in length of snout, 2 in interorbital width. Dorsal 26–28, $\frac{2}{3}$ length of anal, originating twice as far from the end of the snout as from the base of the caudal. Anal 39–42, originating considerably in advance of the dorsal (its 10th or 11th ray corresponding to the first dorsal ray), and at equal distance from head and root of caudal. Pectoral nearly $\frac{1}{2}$ length of head, ventral $\frac{1}{3}$. Caudal rather small, scaled at the

base, with rounded lobes. Caudal peduncle twice as long as deep, $\frac{1}{2}$ length of head. 93-95 scales in the lateral line, $\frac{16}{22-24}$ in a transverse line on the body, 25-27 in a transverse line between dorsal and anal, 20 round caudal peduncle. Olive above, bluish white beneath.

Nile.

3. MORMYROPS LONGICEPS.

Mormyrops longiceps, Günth. Ann. & Mag. N. H. (3) xx. 1867, p. 117.

Depth of body 7 times in total length, length of head 4. Head very low and elongate, more than twice as long as deep; upper jaw somewhat longer than the lower; teeth truncate and notched at the apex, $\frac{2\frac{1}{2}}{2}$; eye very small, situated in the anterior third of the head. Dorsal 26, more than half as long as anal. Anal 39. Lat. l. 90. Coloration uniform.

Total length 280 millim.

Bossumprah River, Gold Coast.—The type specimen, which should be in the Liverpool Museum, could not be found by Dr. H. O. Forbes, to whom I applied for information respecting it.

4. MORMYROPS BREVICEPS.

Mormyrops breviceps, Steind. Notes Leyd. Mus. xvi. 1894, p. 66, pl. i. fig. 2.

Depth of body $7\frac{2}{3}$ times in total length, length of head $5\frac{1}{2}$. Head nearly twice as long as deep, upper profile slightly concave; snout rounded, the upper jaw a little longer than the lower; teeth truncate or slightly notched, 20 in each jaw; eye small, its diameter 2 in length of snout. Dorsal 26, $\frac{3}{5}$ length of anal, originating considerably nearer base of caudal than head. Anal 43, originating considerably in advance of dorsal (its 13th ray corresponding to the first dorsal ray), and a little nearer head than base of caudal. Pectoral a little more than $\frac{1}{2}$ length of head, ventral $\frac{1}{3}$. Caudal rather small, with rounded lobes. Caudal peduncle $2\frac{1}{2}$ as long as deep, $\frac{2}{3}$ length of head. 90 scales in the lateral line.

Total length 355 millim.

St. Paul R., Liberia.—Type in Leyden Museum.

5. MORMYROPS ZANCLIROSTRIS.

Mormyrus zanclirostris, Günth. Ann. & Mag. N. H. (3) xx. 1867, p. 114, pl. ii. fig. B.

Mormyrops zanclirostris, Bouleng. Ann. Mus. Congo, Zool. i. 1898, p. 3.

Depth of body $6\frac{1}{2}$ to 7 times in total length, length of head $3\frac{1}{2}$ to 4 times. Head $2\frac{1}{2}$ to $2\frac{3}{4}$ as long as deep; snout much produced, tubiform, nearly as long as postorbital part of head; mouth terminal, very small; teeth truncate, 14 in each jaw; eye very small, situated in the anterior half of the head, its diameter $\frac{1}{2}$ to $\frac{2}{3}$ interorbital width. Dorsal 20-21, $\frac{1}{2}$ length of anal, originating 3 to $3\frac{1}{2}$

times as far from the head as from the base of the caudal. Anal 36-39, originating considerably in advance of dorsal (its 12th to 14th ray corresponding to the first dorsal ray), and at nearly equal distance from head and base of caudal. Pectoral $\frac{2}{5}$ length of head, ventral $\frac{1}{4}$. Caudal small, densely scaled in its basal half, with rounded lobes. Caudal peduncle twice as long as deep, $\frac{1}{3}$ length of head. 70-74 scales in the lateral line, $\frac{9-10}{14-16}$ in a transverse line on the body, 14 or 15 in a transverse line between dorsal and anal, 12 round caudal peduncle. Dark brown.

Total length 270 millim.

Gaboon, Ogowe.

6. MORMYROPS ENGYSTOMA.

Mormyrops engystoma, Bouleng. Ann. Mus. Congo, Zool. i. 1898, p. 3, pl. i. fig. 1.

Depth of body 7 to $7\frac{1}{2}$ times in total length, length of head $4\frac{1}{2}$ to 5. Head nearly twice as long as deep, with straight declivous upper profile; snout rounded, projecting a little beyond the mouth; width of mouth hardly $\frac{2}{3}$ length of snout; teeth notched, 12 in each jaw; eye very small, situated in the anterior third of the head, its diameter 3 times in length of snout, $2\frac{1}{2}$ to 3 times in interorbital width. Dorsal 19-20, $\frac{1}{2}$ length of anal, originating twice as far from the end of the snout as from the base of the caudal. Anal 35-37, originating considerably in advance of dorsal (its 9th ray corresponding to the first dorsal ray), and equally distant from head and base of caudal. Pectoral $\frac{3}{5}$ length of head, ventral $\frac{2}{5}$. Caudal rather small, scaled at the base, with rounded lobes. Caudal peduncle 2 to $2\frac{1}{2}$ as long as deep, $\frac{1}{2}$ to $\frac{2}{3}$ length of head. 80-93 scales in the lateral line, $\frac{12-13}{20-22}$ in a transverse line on the body, 18-19 in a transverse line between dorsal and anal, 16 round caudal peduncle. Pale brown, speckled with darker.

Total length 145 millim.

Lower Congo.

7. MORMYROPS MASUIANUS.

Mormyrops masuianus, Bouleng. Ann. Mus. Congo, Zool. i. 1898, p. 4, pl. ii. fig. 1.

Depth of body 6 times in total length, length of head $4\frac{2}{3}$. Head $1\frac{2}{3}$ as long as deep, with straight, declivous upper profile; snout rounded, projecting a little beyond the mouth; width of mouth a little greater than length of snout; teeth truncate, 12 in the upper jaw, 14 in the lower; eye very small, situated in the anterior third of the head, its diameter 3 times in length of snout or interorbital width. Dorsal 30, $\frac{4}{5}$ length of anal, originating $1\frac{2}{3}$ as far from the end of the snout as from the base of the caudal. Anal 40, originating a little in advance of dorsal (its 7th ray corresponding to the first dorsal ray), and slightly nearer head than base of caudal. Pectoral $\frac{1}{2}$ length of head, ventral $\frac{1}{3}$. Caudal rather small, densely scaled, with rounded lobes. Caudal

peduncle $2\frac{1}{2}$ as long as deep, $\frac{1}{2}$ length of head. 93 scales in the lateral line, $\frac{14}{20}$ in a transverse line on the body, 21 in a transverse line between dorsal and anal, 18 round caudal peduncle. Pale brownish.

Total length 410 millim.

Upper Congo.

8. MORMYROPS SIRENOIDES.

Mormyrops sirenoïdes, Bouleng. Ann. Mus. Congo, Zool. i. 1898, p. 4, pl. i. fig. 2.

Depth of body 7 times in total length, length of head 6. Head $1\frac{1}{2}$ as long as deep, with straight, declivous upper profile; snout rounded, projecting a little beyond the mouth; width of mouth greater than length of snout; teeth truncate, 12 in each jaw; eye very small, situated in the anterior third of the head, its diameter 3 times in length of snout, 4 times in interorbital width. Dorsal 30, $\frac{2}{3}$ length of anal, originating $1\frac{1}{2}$ as far from the end of the snout as from the base of the caudal. Anal 47, originating considerably in advance of dorsal (its 14th ray corresponding to the first dorsal ray), and at nearly equal distance from end of snout and root of caudal. Pectoral a little more than $\frac{1}{2}$ length of head, ventral $\frac{1}{3}$. Caudal small, densely scaled, with rounded lobes. Caudal peduncle $2\frac{1}{2}$ as long as deep, $\frac{1}{2}$ length of head. 90 scales in the lateral line, $\frac{12}{19}$ in a transverse line on the body, 20 in a transverse line between dorsal and anal, 18 round caudal peduncle. Uniform dark brown, somewhat lighter beneath.

Total length 630 millim.

Upper Congo.

9. MORMYROPS LINEOLATUS.

Mormyrops lineolatus, Bouleng. Ann. Mus. Congo, Zool. i. 1898, p. 5, pl. ii. fig. 2.

Depth of body 6 times in total length, length of head nearly 5 times. Head $1\frac{3}{4}$ as long as deep, upper profile slightly concave; snout rounded; jaws equal; width of mouth nearly equal to length of snout; teeth truncate, 16 in each jaw; eye very small, situated in the anterior third of the head, its diameter 3 times in length of snout, $2\frac{1}{2}$ in interorbital width. Dorsal 29, $\frac{2}{5}$ length of anal, originating $1\frac{2}{3}$ as far from the end of the snout as from the base of the caudal. Anal 48, originating considerably in advance of dorsal (the 11th ray corresponding to the first dorsal ray), and a little nearer head than root of caudal. Pectoral $\frac{1}{2}$ length of head, ventral not quite $\frac{1}{3}$. Caudal small, densely scaled, with rounded lobes. Caudal peduncle as long as deep, $\frac{1}{3}$ length of head. 80 scales in the lateral line, $\frac{16}{20}$ in a transverse line on the body, 23 in a transverse line between dorsal and anal, 16 round caudal peduncle. Pale brown, with dark lines along the series of scales.

Total length 400 millim.

Upper Congo.

10. MORMYROPS MARIE.

Mormyrus (Mormyrops) marie, Schilthuis, Tijdschr. Ned. Dierk. Ver. (2) iii. 1891, p. 92.

Mormyrops marie, Bouleng. Ann. Mus. Congo, Zool. i. 1898, p. 3.

Depth of body $5\frac{1}{2}$ to $6\frac{1}{2}$ times in total length, length of head 4 to 5 times. Head nearly twice as long as deep, with slightly concave upper profile; snout rounded, jaws equal; width of mouth a little less than length of snout; teeth truncate, 14 or 16 in each jaw; eye very small, situated in the anterior third of the head, its diameter 3 or 4 times in length of snout, $2\frac{1}{2}$ to $3\frac{1}{2}$ times in interorbital width. Dorsal 34–37, $\frac{3}{4}$ to $\frac{4}{5}$ length of anal, originating at equal distance from the head and the base of the caudal, or a little nearer the latter. Anal 50–59, originating in advance of dorsal (its 8th or 9th ray corresponding to the first dorsal ray), and much nearer base of caudal than end of snout. Pectoral $\frac{1}{2}$ length of head, ventral $\frac{1}{3}$ to $\frac{2}{5}$. Caudal very small, scaled at the base, with rounded lobes. Caudal peduncle not longer than deep, $\frac{1}{5}$ to $\frac{1}{6}$ length of head. 100–105 scales in the lateral line, $\frac{18-20}{26-30}$ in a transverse line on the body, 28–31 in a transverse line between dorsal and anal, 22–24 round caudal peduncle. Whitish, uniform or finely speckled with brown.

Total length 300 millim.

Lower Congo.

11. MORMYROPS MICROSTOMA.

Mormyrops microstoma, Bouleng. Ann. Mus. Congo, Zool. i. 1898, p. 6, pl. i. fig. 3.

Depth of body $6\frac{1}{3}$ times in total length, length of head $4\frac{2}{3}$. Head twice as long as deep, with straight upper profile; snout rounded, projecting beyond the mouth; width of mouth $\frac{2}{3}$ length of snout; teeth truncate, 14 in each jaw; eye moderate, its diameter $1\frac{1}{2}$ in length of snout, 2 in interorbital width. Dorsal 45, nearly $\frac{3}{4}$ length of anal, originating nearly twice as far from the end of the snout as from the base of the caudal. Anal 70, originating considerably in advance of dorsal (its 17th ray corresponding to the first dorsal ray), and nearer the head than base of caudal. Pectoral $\frac{1}{2}$ length of head, ventral nearly $\frac{1}{3}$. Caudal very small, scaled at the base, with rounded lobes. Caudal peduncle hardly as long as deep, $\frac{1}{6}$ length of head. 102 scales in the lateral line, $\frac{12}{15}$ in a transverse line on the body, 16 in a transverse line between dorsal and anal, 14 round caudal peduncle. Blackish brown.

Total length 165 millim.

Upper Congo.

12. MORMYROPS ATTENUATUS.

Mormyrops attenuatus, Bouleng. Ann. Mus. Congo, Zool. i. 1898, p. 6, pl. i. fig. 4.

Depth of body $8\frac{1}{2}$ times in total length, length of head $6\frac{1}{2}$.

Head nearly twice as long as deep, upper profile straight, declivous; snout rounded, projecting a little beyond the mouth; width of mouth $\frac{2}{3}$ length of snout; teeth truncate, 12 in the upper jaw, 14 in the lower; eye small, situated in the anterior third of the head, its diameter $2\frac{1}{2}$ times in length of snout or interorbital width. Dorsal 43, $\frac{3}{4}$ length of anal, originating a little nearer base of caudal than head. Anal 63, originating considerably in advance of dorsal (its 14th ray corresponding to the first dorsal ray), and at equal distance from end of snout and base of caudal. Pectoral a little more than $\frac{1}{2}$ length of head, ventral nearly $\frac{2}{5}$. Caudal very small, scaled at the base, with rounded lobes. Caudal peduncle hardly as long as deep, $\frac{1}{6}$ length of head. 95 scales in the lateral line, $\frac{12}{17}$ in a transverse line on the body, 18 in a transverse line between dorsal and anal, 16 round caudal peduncle. Whitish, finely speckled with brown.

Total length 410 millim.

Upper Congo.

2. PETROCEPHALUS.

Petrocephalus, part., Marcusen, Bull. Ac. St. Pétersb. xii. 1854, p. 14, and Mém. Ac. St. Pétersb. (7) vii. 1864, no. 4, p. 111.

Petrocephalus, Gill, Proc. Ac. Philad. 1862, p. 443 (1863); Bouleng. Ann. Mus. Congo, Zool. i. 1898, p. 2.

Teeth in the jaws bicuspid, forming a single complete series on the entire edge of both jaws (10-24 in the upper jaw, 18-36 in the lower); minute conical teeth on the parasphenoid and on the tongue; mouth inferior, situated below the eyes. Nostrils close together, close to the eye. Body short; ventrals nearer pectorals than anal. Dorsal and anal not very unequal in length. Vertebrae 42 (9 + 4-6 + 27-29).

Synopsis of the Species.

- I. Dorsal 29-33; Anal 33-37; 12 scales round caudal peduncle; lat. l. 40-50.
- Width of mouth $\frac{1}{3}$ - $\frac{1}{4}$ length of head; caudal peduncle $\frac{3}{4}$ - $\frac{1}{2}$ length of head 1. *bane* Lacép.
- Width of mouth $\frac{2}{3}$ length of head; caudal peduncle $\frac{2}{3}$ - $\frac{2}{5}$ length of head 2. *sauvaggi* Blgr.
- II. Dorsal 20-28.
- A. 10 or 12 scales round caudal peduncle.
- D. 20-25; A. 31-33; lat. l. 39-40 3. *bovei* C. & V.
- D. 21-24; A. 28-30; lat. l. 37; $\frac{7}{8}$ scales in a series between dorsal and anal; caudal peduncle $2\frac{1}{2}$ -3 times as long as deep 4. *balayi* Sauv.
- D. 24-28; A. 30-33; lat. l. 38-42; $\frac{11-13}{11-12}$ scales in a series between dorsal and anal; caudal peduncle 3 times as long as deep 5. *simus* Sauv.
- D. 27; A. 29; lat. l. 40; $\frac{12}{14}$ scales in a series between dorsal and anal; caudal peduncle $2\frac{1}{2}$ as long as deep . 6. *gliroides* Vincig.
- B. 16 scales round caudal peduncle.
- D. 20-22; A. 25-29; lat. l. 37-40 7. *catostoma* Gthr.

1. PETROCEPHALUS BANE.

Mormyrus bane, Lacép. Hist. Poiss. v. p. 620 (1803); Cuv. & Val. xix. p. 276 (1846); Günth. Cat. vi. p. 220 (1866).

Mormyrus cyprinoides (non L.), Geoffr. Descr. Égypte, Poiss. p. 277, pl. viii. figs. 3 & 4 (1829).

Mormyrus dequesne, Cuv. & Val. t. c. p. 281.

? *Mormyrus joannisii*, Cuv. & Val. t. c. p. 282.

Mormyrus ehrenbergii, Cuv. & Val. t. c. p. 283.

Petrocephalus bane, Marcusen, Bull. Ac. St. Pétersb. xii. 1854, p. 14, and Mém. Ac. St. Pétersb. (7) vii. 1864, no. 4, p. 146.

Petrocephalus dequesne, Marcusen, Bull. p. 14.

? *Petrocephalus de joannis*, Marcusen, l. c.

Petrocephalus ehrenbergii, Marcusen, l. c.

Depth of body $2\frac{1}{2}$ to $3\frac{1}{3}$ times in total length, length of head $3\frac{3}{4}$ to 4. Head as long as deep, rounded; snout very short, $\frac{1}{6}$ to $\frac{1}{5}$ length of head, rounded, projecting beyond the mouth; mouth situated below the eye, its width $\frac{1}{5}$ to $\frac{1}{4}$ length of head; teeth bicuspid, 14–22 in the upper jaw, 22–30 in the lower; nostrils close together, close to the eye and on a level with its lower border; eye large, longer than the snout, at least $\frac{2}{3}$ interorbital width. Dorsal 29–33, originating above 6th to 10th ray of anal, its length $1\frac{2}{3}$ to 2 in its distance from head. Anal 34–37, equally distant from base of ventral and from base of caudal. Pectoral pointed, $\frac{4}{5}$ length of head, twice as long as ventral, and extending beyond base of latter. Caudal with pointed lobes. Caudal peduncle $2\frac{1}{2}$ to 3 times as long as deep, $\frac{3}{4}$ to $\frac{4}{5}$ length of head. 40–50 scales in the lateral line, $\frac{10-11}{13-16}$ in a transverse line on the body, $\frac{11-14}{12-13}$ in a transverse line between dorsal and anal, 12 round caudal peduncle. Silvery, greyish on the back.

Total length 195 millim.

Nile.

2. PETROCEPHALUS SAUVAGII.

Mormyrus (Petrocephalus) sawagii, Bouleng. Ann. & Mag. N. H. (5) xix. 1887, p. 149.

Depth of body 3 to $3\frac{1}{2}$ times in total length, length of head $3\frac{2}{3}$ to 4. Head as long as deep, with straight, descending upper profile; snout very short, $\frac{1}{6}$ to $\frac{1}{5}$ length of head, obliquely truncate, projecting beyond the mouth; mouth situated below the anterior border of the eye, its width $\frac{2}{7}$ length of head; teeth bicuspid, 20–24 in the upper jaw, 28–30 in the lower; nostrils close together, close to the eye; eye large, its diameter greater than length of snout, nearly equal to interorbital width. Dorsal 29–31, originating above 4th or 5th ray of anal, its length a little more than half its distance from head. Anal 35–36, equally distant from base of ventral and base of caudal, or slightly nearer latter. Pectoral pointed, about $\frac{2}{3}$ length of head, twice as long as ventral, and extending beyond base of latter. Caudal scaled at the base, with pointed lobes. Caudal peduncle 3 times as long as deep, $\frac{3}{5}$ to $\frac{2}{3}$

length of head. 40–46 scales in the lateral line, $\frac{10-11}{13-14}$ in a transverse line on the body, $\frac{10-11}{10-12}$ in a transverse line between dorsal and anal, 12 round caudal peduncle. Plumbeous above.

Total length 190 millim.

Lower Congo, Old Calabar.

3. PETROCEPHALUS BOVEI.

Mormyrus bovei, Cuv. & Val. xix. p. 283 (1846); Günth. Cat. vi. p. 221 (1866); Steind. Sitzb. Ak. Wien, lxi. i. 1870, p. 553.

Petrocephalus bovei, Marcusen, Bull. Ac. St. Pétersb. xii. 1854, p. 14.

Shape of head and body as in *M. bane*; depth of body about $3\frac{1}{2}$ times in total length. Dorsal 20–25; anal 31–33. 39–40 scales in the lateral line.

Nile, Senegal.—This species is only known to me from the accounts given by Valenciennes and by Steindachner.

4. PETROCEPHALUS BALAYI.

Petrocephalus balayi, Sauvage, Bull. Soc. Philom. (7) vii. 1883, p. 159.

Mormyrus amblystoma, Günth. Ann. & Mag. N. H. (6) xvii. 1896, p. 281, pl. xiv. fig. A.

Depth of body $2\frac{3}{5}$ times in total length, length of head $3\frac{2}{3}$. Head as long as deep, with convex upper profile; snout very short, $\frac{1}{6}$ length of head, obliquely truncate, projecting beyond the mouth; mouth situated below anterior border or centre of eye, its width $\frac{1}{3}$ length of head; teeth bicuspid, 20–24 in the upper jaw, 30–36 in the lower; nostrils close together, close to the eye; eye large, its diameter greater than length of snout, $\frac{2}{3}$ interorbital width. Dorsal 21–24, originating above 4th or 5th ray of anal, its length nearly $\frac{1}{2}$ its distance from head. Anal 28–30, slightly nearer base of caudal than base of ventral. Pectoral pointed, $\frac{2}{3}$ length of head, $1\frac{3}{4}$ length of ventral, extending beyond base of latter. Caudal scaled at the base, with pointed lobes. Caudal peduncle $2\frac{1}{2}$ to 3 times as long as deep, $\frac{2}{3}$ to $\frac{3}{4}$ length of head. 35–37 scales in the lateral line, $\frac{6-8}{11-12}$ in a transverse line on the body, $\frac{7-8}{8}$ in a transverse line between dorsal and anal, 10 or 12 round caudal peduncle. Brown above, silvery below; a dark spot at base of caudal, and another below origin of dorsal.

Total length 145 millim.

Ogowe, Congo.

5. PETROCEPHALUS SIMUS.

Petrocephalus simus, Sauvage, Bull. Soc. Philom. (7) iii. 1878, p. 100.

Mormyrus (Petrocephalus) simus, Sauvage, N. Arch. Mus. (2) iii. 1880, p. 51, pl. ii. fig. 3.

Mormyrus tenuicauda, Steind. Notes Leyd. Mus. xvi. 1894 p. 69, pl. iv. fig. 1.

Mormyrus simus, Günth. Ann. & Mag. N. H. (6) xvii. 1896, p. 282.

Depth of body $2\frac{4}{5}$ to $3\frac{1}{3}$ times in total length, length of head 4 to $4\frac{1}{4}$. Head as long as deep, with convex upper profile; snout very short, $\frac{1}{5}$ length of head; obliquely truncate, projecting beyond the mouth; mouth situated below the anterior border of the eye, its width $\frac{1}{5}$ to $\frac{1}{4}$ length of head; teeth bicuspid, 14–18 in the upper jaw, 20–24 in the lower; nostrils close together, in front of the eye; eye rather large, a little longer than the snout, $\frac{2}{3}$ interorbital width. Dorsal 24–28, originating above 5th to 7th ray of anal, its length $1\frac{3}{4}$ to 2 in its distance from head. Anal 30–33, equally distant from base of ventral and from base of caudal. Pectoral pointed, $\frac{4}{5}$ length of head, twice as long as ventral, extending beyond base of latter. Caudal scaled at the base, with pointed lobes. Caudal peduncle 3 times as long as deep, $\frac{3}{4}$ to $\frac{4}{5}$ length of head. 38–42 scales in the lateral line, $\frac{9-10}{11-12}$ in a transverse series on the body, $\frac{11-13}{11-12}$ in a transverse series between dorsal and anal, 12 round caudal peduncle. Brown above, silvery beneath; anterior part of dorsal blackish.

Total length 120 millim.

Ogowe, Liberia.

6. PETROCEPHALUS GLIROIDES.

Mormyrus gliroides, Vincig. Ann. Mus. Genova, (2) xvi. 1897, p. 353.

Depth of body $2\frac{4}{5}$ times in total length, length of head $3\frac{2}{5}$. Head nearly as long as deep; snout prominent, rounded, hardly $\frac{1}{4}$ length of head; mouth inferior, situated below anterior third of eye, its width $\frac{1}{5}$ length of head; teeth bicuspid, 14 in the upper jaw, 24 in the lower; eye moderate, slightly shorter than the snout, $\frac{1}{5}$ length of head, $\frac{1}{2}$ interorbital width. Dorsal 27, originating above 3rd ray of anal, at equal distance from head and base of caudal. Anal 29, equally distant from base of ventral and from base of caudal. Pectoral pointed, $\frac{2}{3}$ length of head. Caudal peduncle $2\frac{1}{2}$ as long as deep. About 40 scales in the lateral line, $\frac{12}{12}$ in a transverse line on the body, $\frac{12}{14}$ in a transverse line between dorsal and anal, 12 round caudal peduncle. Greyish above, yellowish beneath.

Total length 125 millim.

Between Ganana and Lugh, Somaliland.—I am indebted to the kindness of Prof. Gestro for the loan of the type specimen, preserved in the Genoa Museum.

7. PETROCEPHALUS CATOSTOMA.

Mormyrus catostoma, Günth. Cat. vi. p. 222 (1866).

Depth of body 3 to $3\frac{1}{3}$ times in total length, length of head $3\frac{1}{2}$ to $3\frac{2}{3}$. Head as long as deep, with convex upper profile; snout very short, $\frac{1}{5}$ length of head, obliquely truncate, projecting beyond

the mouth; mouth situated below the eye, its width $\frac{1}{4}$ length of head; teeth bicuspid, 12-14 in the upper jaw, 18-20 in the lower; nostrils close together, close to the eye; eye large, longer than the snout, at least $\frac{3}{4}$ interorbital width. Dorsal 20-22, originating above 4th or 5th ray of anal, its length hardly half its distance from head. Anal 25-29, equally distant from base of ventral and from base of caudal. Pectoral pointed, nearly $\frac{3}{4}$ length of head, twice as long as ventral, and extending beyond base of latter. Caudal with pointed lobes. Caudal peduncle $2\frac{1}{2}$ to 3 times as long as deep, almost as long as head. 37-40 scales in the lateral line, $\frac{9-10}{13-15}$ in a transverse line on the body, $\frac{10-11}{10-11}$ in a transverse line between dorsal and anal, 16 round caudal peduncle. Silvery, back blackish.

Total length 55 millim.

Rovuma River and Lake Nyassa.

3. ISICHTHYS.

Isichthys, Gill, Proc. Ac. Philad. 1862, p. 444 (1863); Bouleng. Ann. Mus. Congo, Zool. i. 1898, p. 2.

Teeth rather large, few, 5-6 in the upper jaw, 6 in the lower; minute conical teeth on the parasphenoid and on the tongue; mouth subinferior, below the level of the eye. Body much elongate; ventrals much nearer anal than pectorals. Dorsal a little longer than anal. Vertebrae 64 (26 + 38).

1. ISICHTHYS HENRYI.

Isichthys henryi, Gill, Proc. Ac. Philad. 1862, p. 444.

Mormyrops henryi, Günth. Cat. vi. p. 224 (1866); Hubrecht, Notes Leyd. Mus. iii. 1881, p. 70.

Mormyrus henryi, Günth. Ann. & Mag. N. H. (3) xx. 1867, p. 115; Steind. Notes Leyd. Mus. xvi. 1894, p. 66.

Mormyrus cobitiformis, Peters, Sitzb. Ges. nat. Fr. Berl. 1882, p. 72.

Mormyrus (Isistius) henryi, Sauvage, Bull. Soc. Zool. France, 1884, p. 207, pl. vi. fig. 1.

Depth of body 10 or 11 times in total length, length of head 6 to $7\frac{1}{2}$ times. Head $1\frac{3}{4}$ to twice as long as deep; snout rounded, $\frac{1}{5}$ to $\frac{1}{4}$ length of head; mouth subinferior, below level of eye, its width $\frac{1}{4}$ length of head; teeth notched, 5 or 6 in the upper jaw, 6 in the lower; nostrils midway between eye and end of snout; eye small, hardly $\frac{1}{2}$ length of snout, $\frac{1}{3}$ interorbital width. Dorsal 39-50, longer than its distance from the head. Anal 38-47, originating a little posterior to origin of dorsal. Pectoral about $\frac{1}{2}$ length of head. Caudal small, with obtusely pointed lobes. Caudal peduncle twice as long as deep, $\frac{1}{2}$ length of head. 120-140 scales in the lateral line, $\frac{9}{9}$ between dorsal and anal, 18-20 round caudal peduncle. Dark brown.

Total length 205 millim.

West Africa, from Liberia to Mayumba, French Congo.

4. MARCUSENIUS.

Petrocephalus, part., Marcusen, Bull. Ac. St. Pétersb. xii. 1854, p. 14, and Mém. Ac. St. Pétersb. (7) vii. 1864, no. 4, p. 113.

Marcusenius, Gill, Proc. Ac. Philad. 1862, p. 129 (1863); Bouleng. Ann. Mus. Congo, Zool. i. 1898, p. 2.

Heteromormyrus, Steind. Verh. zool.-bot. Ges. Wien, xvi. 1866, p. 765.

Teeth in the jaws small, truncate or notched, few (3-9 in the upper jaw, 4-10 in the lower); minute conical teeth on the parasphenoid and on the tongue; mouth inferior or subinferior, below the level of the eyes. Nostrils widely separated. Body short or moderately elongate; ventrals midway between pectorals and anal, or nearer the former. Dorsal and anal subequal in length, or either the longer. Vertebrae 41-46 (9-12 + 4-5 + 27-30).

Synopsis of the Species.

I. Anal originating before dorsal.

A. Caudal peduncle 4 to 5 times as long as deep.

D. 22-24; A. 30-31; L. l. 62; 12 scales round caudal peduncle.....

1. *marchii* Sauv.

B. Caudal peduncle 2 to 3 times as long as deep, surrounded by 12 scales.

D. 20; A. 25-26; L. l. 67

2. *sphecodes* Sauv.

D. 15-18; A. 25-30; L. l. 58-64

3. *brachyhystius* Gill.

D. 18; A. 22; L. l. 55.....

4. *kingsleyæ* Gthr.

D. 20-21; A. 27-28; L. l. 46-50; caudal peduncle 3 times as long as deep

5. *adpersus* Gthr.

D. 20; A. 28; L. l. 48; caudal peduncle twice as long as deep

6. *lhuyssii* Sldr.

C. Caudal peduncle $1\frac{1}{2}$ as long as deep, $\frac{1}{2}$ length of head.

D. 18; A. 23; L. l. 70; about 20 scales round caudal peduncle.....

7. *pauciradiatus* Sldr.

II. Dorsal originating before anal.

A. Caudal peduncle 4 times as long as deep.

D. 35; A. 30; L. l. 55; 16 scales round caudal peduncle

8. *plagiostoma* Blgr.

B. Caudal peduncle 2 to 3 times as long as deep.

D. 38-40; A. 25-27; L. l. 61-68; 12 scales round caudal peduncle, which is 3 times as long as deep...

9. *wilverthi* Blgr.

D. 30-36; A. 23-27; L. l. 65-70; 14 scales round caudal peduncle, which is twice as long as deep ...

10. *discorhynchus* Ptrs.

D. 35-36; A. 26; L. l. 55-60; 12 scales round caudal peduncle, which is $2\frac{1}{2}$ as long as deep

11. *petherici* Blgr.

D. 33; A. 23; L. l. 60; 12 scales round caudal peduncle, which is 3 times as long as deep

12. *psittacus* Blgr.

D. 17-22; A. 20-24; L. l. 53-60; 16 scales round caudal peduncle.....

13. *isidori* C. & V.

1. MARCUSENIUS MARCHII.

Petrocephalus marchei, Sauvage, Bull. Soc. Philom. (7) iii. 1878, p. 100.

Mormyrus marcheii, Sauvage, N. Arch. Mus. (2) iii. 1880, p. 50, pl. ii. fig. 5; Günth. Ann. & Mag. N. H. (6) xvii. 1896, p. 287.

Marcusenius marchii, Bouleng. Ann. Mus. Congo, Zool. i. 1898, p. 7.

Depth of body $3\frac{1}{2}$ to 4 times in total length, length of head $4\frac{1}{2}$ to 5. Head nearly as long as deep; snout rounded, $\frac{2}{7}$ length of head, projecting a little beyond the mouth; latter small, inferior, its width $\frac{1}{5}$ length of head; teeth truncate or feebly notched, 5 in the upper jaw, 6 in the lower; nostrils halfway between end of snout and eye; eye moderate, $\frac{2}{3}$ length of snout, a little more than $\frac{1}{2}$ interorbital width. Dorsal 22-24, originating above 10th ray of anal, its length $2\frac{1}{2}$ in its distance from head. Anal 30-31, $1\frac{1}{2}$ as long as dorsal, nearer base of ventral than base of caudal. Pectoral pointed, as long as head, twice as long as ventral, extending beyond base of latter. Caudal with pointed lobes. Caudal peduncle 4 to 5 times as long as deep, a little longer than head. 62 scales in the lateral line, $\frac{7}{16}$ in a transverse line on the body, $\frac{11}{8}$ in a transverse line between dorsal and anal, 12 round caudal peduncle. Olive-brown above, silvery beneath; head speckled with brown.

Total length 160 millim.

Ogowe.

2. MARCUSENIUS SPHECODES.

Mormyrops sphaecodes, Sauvage, Bull. Soc. Philom. (7) iii. 1878, p. 101, and N. Arch. Mus. (2) iii. 1880, p. 55, pl. ii. fig. 4.

Mormyrus sphaecodes, Günth. Ann. & Mag. N. H. (6) xvii. 1896, p. 280.

Marcusenius sphaecodes, Bouleng. Ann. Mus. Congo, Zool. i. 1898, p. 7.

Depth of body equal to length of head, 5 times in total length. Head $1\frac{1}{4}$ as long as deep; snout rounded, $\frac{1}{4}$ length of head; mouth small, subinferior, its width $\frac{1}{5}$ length of head; teeth small, notched, 5 in the upper jaw, 6 in the lower; nostrils on a line with the lower border of the eye, midway between eye and end of snout; eye small, $\frac{1}{2}$ length of snout, $\frac{1}{3}$ interorbital width. Dorsal 20, originating above 5th ray of anal, not $\frac{1}{2}$ as long as its distance from the head. Anal 25-26, equally distant from base of ventral and from base of caudal. Pectoral pointed, $\frac{3}{4}$ length of head, $1\frac{1}{2}$ length of ventral, reaching base of latter. Caudal with pointed lobes. Caudal peduncle 3 times as long as deep, nearly as long as head. 67 scales in the lateral line, $\frac{12}{16}$ in a transverse line on the body, $\frac{9}{8}$ in a transverse line between dorsal and anal, 12 round caudal peduncle. Brown.

Total length 130 millim.

Ogowe.

3. MARCUSENIUS BRACHYHISTIUS.

Marcusenius brachyistius, Gill, Proc. Ac. Philad. 1862, p. 139.

Mormyrus brachyistius, Günth. Cat. vi. p. 219 (1866).

Mormyrus microcephalus, Günth. Ann. & Mag. N. H. (3) xx. 1867, p. 115.

Mormyrus liberiensis, Steind. Notes Leyd. Mus. xvi. 1894, p. 67.

Depth of body $4\frac{1}{3}$ to $5\frac{1}{3}$ times in total length, length of head $4\frac{1}{2}$ to $6\frac{1}{3}$. Head $1\frac{1}{5}$ to $1\frac{1}{4}$ as long as deep, snout convex, $\frac{1}{4}$ to $\frac{2}{7}$ length of head, slightly projecting beyond the mouth; mouth small, subinferior, below level of eye, its width $\frac{1}{5}$ length of head; teeth small, feebly notched, 5 in the upper jaw, 6 in the lower; nostrils nearly equally distant from end of snout and from eye, anterior on a level with centre of latter, posterior with lower border; eye small, about $\frac{1}{2}$ length of snout or interorbital width. Dorsal 15–18, hardly $\frac{1}{3}$ as long as its distance from head, originating above 10th to 14th ray of anal. Anal 25–30, nearly twice to $2\frac{1}{2}$ as long as dorsal, nearer base of caudal than base of ventral. Pectoral obtusely pointed, at least $\frac{3}{4}$ length of head, $1\frac{1}{2}$ to $1\frac{2}{3}$ length of ventral, reaching base of latter. Caudal densely scaled in the basal half, with pointed lobes. Caudal peduncle $2\frac{1}{2}$ to 3 times as long as deep, as long as head or a little shorter. 58–64 scales in the lateral line, $\frac{8-10}{13-14}$ in a transverse line on the body, $\frac{7-8}{6-7}$ in a transverse line between dorsal and anal, 12 round caudal peduncle. Brown.

Total length 175 millim.

West Africa, from Sierra Leone to the Congo.

4. MARCUSENIUS KINGSLEYÆ.

Mormyrus kingsleyæ, Günth. Ann. & Mag. N. H. (6) xvii. 1896, p. 281, pl. xv. fig. A.

Marcusenius kingsleyæ, Bouleng. Ann. Mus. Congo, Zool. i. 1898, p. 7.

Depth of body $4\frac{1}{2}$ times in total length, length of head 5. Head $1\frac{1}{4}$ as long as deep; snout convex, $\frac{1}{4}$ length of head, slightly projecting beyond the mouth; mouth small, subinferior, below level of eye, its width $\frac{1}{4}$ length of head; teeth feebly notched, 5 in the upper jaw, 6 in the lower; nostrils nearly equally distant from end of snout and from eye, anterior on a level with centre of latter, posterior with lower border; eye small, $\frac{1}{2}$ length of snout, $\frac{2}{5}$ interorbital width. Dorsal 18, its length $\frac{1}{3}$ its distance from head, originating above 8th ray of anal. Anal 22, a little longer than dorsal, nearer base of caudal than base of ventral. Pectoral pointed, $\frac{4}{5}$ length of head, $1\frac{2}{3}$ length of ventral, not reaching base of latter. Caudal densely scaled in the basal half, with pointed lobes. Caudal peduncle $2\frac{1}{2}$ as long as deep, $\frac{3}{4}$ length of head. 55 scales in the lateral line, $\frac{10}{14}$ in a transverse line on the body, $\frac{8}{7}$ in a transverse line between dorsal and anal, 12 round caudal peduncle. Brown.

Total length 100 millim.

Old Calabar.

5. MARCUSENIUS ADSPERSUS.

Mormyrus adspersus, Günth. Cat. vi. p. 221 (1866).

Marcusenius adspersus, Bouleng. Ann. Mus. Congo, Zool. i. 1898, p. 7.

Depth of body 3 times in total length, length of head 4 to $4\frac{1}{3}$. Head as long as deep; snout rounded, $\frac{1}{5}$ length of head; mouth small, subinferior, its width $\frac{1}{5}$ length of head; teeth small, notched, 7 in the upper jaw, 8 in the lower; nostrils on a line with centre of eye, posterior close to eye; eye moderate, as long as snout, $\frac{2}{3}$ interorbital width. Dorsal 20–21, originating above 9th or 10th ray of anal, about $\frac{1}{2}$ as long as its distance from head. Anal 27–28, equally distant from base of ventral and from base of caudal. Pectoral as long as head, twice as long as ventral, reaching nearly to extremity of latter. Caudal with obtusely pointed lobes. Caudal peduncle 3 times as long as deep, nearly as long as head. 46–50 scales in the lateral line, $\frac{10}{14}$ in a transverse line on the body, $\frac{10}{10}$ in a transverse line between dorsal and anal, 12 round caudal peduncle. Brown, dotted with blackish, the dots largest on the head.

Total length 80 millim.

Lagos.

6. MARCUSENIUS LHUYSII.

Mormyrus lhuysii, Steind. Sitzb. Ak. Wien, lxi. i. 1870, p. 553, pl. ii. fig. 3.

Marcusenius lhuysii, Bouleng. Ann. Mus. Congo, Zool. i. 1898, p. 7.

Depth of body $3\frac{1}{4}$ times in total length, length of head $4\frac{1}{2}$. Head a little longer than deep; snout rounded, not quite $\frac{1}{4}$ length of head; mouth small, terminal, but situated below the level of the eyes; no mental swelling; teeth small, truncate, 5 in the upper jaw, 6 in the lower; eye as long as the snout; posterior nostril a little lower down than upper, close to the eye. Dorsal 20, originating above 8th ray of anal, its length $2\frac{1}{2}$ in its distance from head. Anal 28, nearer base of caudal than base of ventral. Pectoral pointed, not quite so long as head, twice as long as ventral, extending as far as the extremity of the latter. Caudal with rounded lobes. Caudal peduncle twice as long as deep, about $\frac{2}{3}$ length of head. 48 scales in the lateral line, 12 round caudal peduncle. Greyish above, silvery beneath, spotted with brown.

Total length 75 millim.

Senegal.—Type in the Vienna Museum.

7. MARCUSENIUS PAUCIRADIATUS.

Mormyrus pauciradiatus, Steind. Verh. zool.-bot. Ges. Wien, xvi. 1866, p. 765, pl. xvii. fig. 2.

Marcusenius pauciradiatus, Bouleng. Ann. Mus. Congo, Zool. i. 1898, p. 7.

Depth of body equal to length of head, 4 times in total length,

Head $1\frac{1}{4}$ as long as deep; snout rounded, $\frac{1}{4}$ length of head; mouth small, subterminal, but situated considerably below the level of the eyes; no mental swelling; teeth small, notched; eye rather small, $\frac{2}{3}$ length of snout; nostrils on a horizontal line on a level with the lower border of the eye, midway between the latter and the end of the snout. Dorsal 18, originating a little posterior to origin of anal, its length 3 times in its distance from head. Anal 23, a little nearer base of caudal than base of ventral. Pectoral shorter than head, hardly reaching base of ventral. Caudal with rounded lobes. Caudal peduncle $1\frac{1}{2}$ as long as deep, $\frac{1}{2}$ length of head. 70 scales in the lateral line, about 20 round caudal peduncle.

Total length 100 millim.

Angola.—Type in the Vienna Museum.

8. MARCUSENIUS PLAGIOSTOMA.

Marcusenius plagiosoma, Bouleng. Ann. Mus. Congo, Zool. i. 1898, p. 7, pl. iii. fig. 1.

Depth of body 3 times in total length, length of head 5. Head as long as deep, with slightly concave upper profile; snout $\frac{1}{5}$ length of head; mouth inferior, below anterior border of eye, its width $\frac{1}{5}$ length of head; teeth very small, feebly notched, 9 in the upper jaw, 10 in the lower; nostrils on a line with lower border of eye, posterior close to the eye; eye moderate, as long as snout, $\frac{2}{3}$ interorbital width. Dorsal 35, as long as its distance from head. Anal 30, originating below 12th ray of dorsal, equally distant from base of ventral and from base of caudal. Pectoral pointed, as long as head, $1\frac{2}{3}$ length of ventral, reaching beyond base of latter. Caudal peduncle 4 times as long as deep, $\frac{3}{4}$ length of head. 55 scales in the lateral line, $\frac{15}{22}$ in a transverse line on the body, $\frac{12}{15}$ in a transverse line between dorsal and anal, 16 round caudal peduncle. Pale brownish above.

Total length 170 millim.

Lower Congo.

9. MARCUSENIUS WILVERTHI.

Marcusenius wilverthi, Bouleng. Ann. Mus. Congo, Zool. i. 1898, p. 8, pl. iv. fig. 1.

Depth of body $2\frac{1}{2}$ to 3 times in total length, length of head $4\frac{3}{4}$ to 5; back gibbose and keeled, with convex outline in front of the dorsal and concave outline on the nape. Head as long as deep, with convex upper and concave lower profile; snout short, $\frac{1}{4}$ to $\frac{1}{3}$ length of head; mouth terminal or subinferior, its width $\frac{1}{4}$ to $\frac{1}{3}$ length of head, much below the level of the eyes; chin with a strong globular swelling; teeth extremely minute, almost hidden in the thick gums, truncate or slightly notched, 3 in the upper jaw, 6 in the lower; nostrils in the posterior half of the snout, posterior a little lower down than anterior, which is on a

level with centre of eye; eye moderate, $\frac{2}{3}$ to $\frac{3}{4}$ length of snout or interorbital width. Dorsal 38-40, $1\frac{2}{3}$ to $1\frac{3}{4}$ length of anal, its length equalling its distance from the head. Anal 25-27, originating below 12th or 13th ray of dorsal, a little nearer base of ventral than base of caudal. Pectoral pointed, a little shorter than head, $1\frac{1}{2}$ to $1\frac{2}{3}$ length of ventral, extending a little beyond base of latter. Caudal scaled in its basal two-thirds, with pointed lobes. Caudal peduncle 3 times as long as deep, $\frac{4}{5}$ length of head. 61-68 scales in the lateral line, $\frac{20-21}{20-21}$ in a transverse line on the body, $\frac{12-14}{13-14}$ in a transverse line between dorsal and anal, 12 round caudal peduncle. Yellowish.

Total length 260 millim.

Congo.

10. MARCUSENIUS DISCORHYNCHUS.

Mormyrus discorhynchus, Peters, Mon. Berl. Ac. 1852, p. 275, and Reise n. Mossamb. iv. p. 75, pl. xiv. (1868).

Marcusenius discorhynchus, Bouleng. Ann. Mus. Congo, Zool. i. 1898, p. 7.

Depth of body 3 to $3\frac{1}{3}$ times in total length, length of head $4\frac{1}{2}$ to $4\frac{2}{3}$. Head as long as deep; snout rounded, $\frac{2}{7}$ length of head; mouth small, subinferior, its width $\frac{1}{5}$ length of head; teeth small, notched, 5 in the upper jaw, 6 in the lower; nostrils on a line with the lower border of the eye, nearer the latter than the end of the snout; eye moderate, a little shorter than the snout, $\frac{2}{3}$ interorbital width. Dorsal 30-36, its length hardly $1\frac{1}{2}$ in its distance from head. Anal 23-27, originating below 10th to 12th ray of dorsal, equally distant from base of ventral and from base of caudal. Pectoral pointed, nearly as long as head, $1\frac{1}{2}$ length of ventral, extending to base of latter or a little beyond. Caudal with obtusely pointed lobes. Caudal peduncle twice as long as deep, a little shorter than head. 65-70 scales in the lateral line, $\frac{17-20}{20-21}$ in a transverse line on the body, $\frac{13-15}{13-15}$ in a transverse line between dorsal and anal, 14 round caudal peduncle. Dark olive or brownish; ventrals red.

Total length 140 millim. (grows to 260).

Lower Zambesi; Lake Nyassa.

11. MARCUSENIUS PETHERICI.

Mormyrus discorhynchus (non Peters), Günth. Cat. vi. p. 220 (1866).

Marcusenius petherici, Bouleng. Ann. Mus. Congo, Zool. i. 1898, p. 7.

Depth of body 3 to $3\frac{1}{4}$ times in total length, length of head $4\frac{2}{3}$ to 5. Head as long as deep; snout rounded, nearly $\frac{1}{4}$ length of head; mouth small, subinferior, its width $\frac{1}{5}$ length of head; teeth small, notched, 5 in the upper jaw, 6 in the lower; nostrils on a line with the lower border of the eye, nearer the latter than

the end of the snout; eye moderate, as long as snout, at least $\frac{2}{3}$ interorbital width. Dorsal 35-36, a little shorter than its distance from head. Anal 26, originating below 15th or 16th ray of dorsal, equally distant from base of ventral and from base of caudal. Pectoral pointed, as long as head, $1\frac{2}{3}$ to $1\frac{3}{4}$ length of ventral, extending beyond base of latter. Caudal with obtusely pointed lobes. Caudal peduncle $2\frac{1}{2}$ as long as deep, as long as head. 55-60 scales in the lateral line, $\frac{18-21}{19-22}$ in a transverse line on the body, $\frac{12-13}{12-13}$ in a transverse line between dorsal and anal, 12 round caudal peduncle. Silvery, brownish on the back.

Total length 210 millim.

Upper Nile.

12. MARCUSENIUS PSITTACUS.

Mormyrus psittacus, Bouleng. Ann. & Mag. N. H. (6) xx. 1897, p. 427.

Marcusenius psittacus, Bouleng. Ann. Mus. Congo, Zool. 1898, p. 7.

Depth of body $3\frac{1}{2}$ times in total length, length of head $4\frac{1}{2}$. Head as long as deep; snout rounded, $\frac{1}{4}$ length of head; mouth small, terminal, below level of eye, its width $\frac{1}{5}$ length of head; teeth small, notched, 3 in the upper jaw, 4 in the lower; chin slightly swollen; nostrils on a line with centre of eye, nearer latter than end of snout; eye rather large, slightly longer than snout, equal to interorbital width. Dorsal 33, as long as its distance from the head. Anal 23, originating below 13th ray of dorsal, equally distant from base of ventral and from base of caudal. Pectoral pointed, a little shorter than head, $1\frac{1}{2}$ as long as ventral, reaching base of latter. Caudal with pointed lobes. Caudal peduncle 3 times as long as deep, as long as head. 60 scales in the lateral line, $\frac{13}{16}$ in a transverse line on the body, $\frac{10}{11}$ in a transverse line between dorsal and anal, 12 round caudal peduncle. Silvery, dark grey on the back.

Total length 125 millim.

Upper Congo.

13. MARCUSENIUS ISIDORI.

Mormyrus isidori, Cuv. & Val. xix. p. 285 (1846); Günth. Cat. p. 221 (1866).

Petrocephalus isidori, Marcusen, Bull. Ac. St. Pétersb. xii. 1854, p. 14, and Mém. Ac. St. Pétersb. (7) vii. 1864, no. 4, p. 150, pl. v. fig. 20.

Marcusenius isidori, Bouleng. Ann. Mus. Congo, Zool. i. 1898, p. 7.

Depth of body 3 to $3\frac{1}{3}$ times in total length, length of head 4 to $4\frac{1}{2}$. Head as long as deep; snout short, rounded, $\frac{1}{5}$ to $\frac{1}{4}$ length of head, projecting beyond the mouth; mouth inferior, just in front of vertical of anterior border of eye, its width $\frac{1}{5}$ to $\frac{1}{4}$

length of head; teeth small, notched, 7 in the upper jaw, 8 in the lower; anterior nostril on a line with centre of eye, halfway between latter and end of snout; posterior nostril close to eye, near its lower border; eye moderate, as long as snout, about $\frac{1}{2}$ interorbital width. Dorsal 17-22, originating above 3rd or 4th ray of anal, its length $\frac{1}{2}$ its distance from head. Anal 20-24, equally distant from base of ventral and from base of caudal. Pectoral pointed, as long as head, nearly $2\frac{1}{2}$ as long as ventral, extending almost as far as extremity of latter. Caudal with pointed lobes. Caudal peduncle $2\frac{1}{2}$ to 3 times as long as deep, a little shorter than head. 53-60 scales in the lateral line, $\frac{9-10}{15}$ in a transverse line on the body, $\frac{11-12}{10-11}$ in a transverse line between dorsal and anal, 16 round caudal peduncle. Silvery.

Total length 90 millim.

Nile.

5. STOMATORHINUS.

Stomatorhinus, Bouleng. Ann. Mus. Congo, Zool. i. 1898, p. 9.

Teeth in the jaws bicuspid, few (7-10 in the upper jaw, 8-10 in the lower); minute conical teeth on the parasphenoid and on the tongue; mouth inferior, considerably in advance of the eyes. Nostrils widely separated, superposed, the lower close to the mouth. Body short; ventrals nearer pectorals than anal. Dorsal and anal subequal in length. Vertebrae 39 (14+25).

1. STOMATORHINUS WALKERI.

Mormyrus walkeri, Günth. Ann. & Mag. N. H. (3) xx. 1867, p. 116, pl. iii. fig. C.

Petrocephalus affinis, Sauvage, Bull. Soc. Philom. (7) iii. 1878, p. 101.

Mormyrus affinis, Sauvage, N. Arch. Mus. (2) iii. 1880, p. 52, pl. ii. fig. 2; Günth. Ann. & Mag. N. H. (6) xvii. 1896, p. 283.

Stomatorhinus walkeri, Bouleng. Ann. Mus. Congo, Zool. i. 1898, p. 9.

Depth of body $3\frac{1}{2}$ to $3\frac{2}{3}$ times in total length, length of head $3\frac{3}{4}$. Head $1\frac{1}{8}$ as long as deep; snout rounded, $\frac{1}{4}$ length of head; mouth small, its width $\frac{1}{5}$ length of head; 10 teeth in either jaw; eye moderate, $\frac{2}{3}$ length of snout, $\frac{1}{2}$ interorbital width. Dorsal 19-20, a little more than $\frac{1}{2}$ as long as its distance from head. Anal 23-25, a little nearer base of caudal than base of ventral, originating a little in advance of dorsal. Pectoral pointed, about $\frac{2}{3}$ length of head, $1\frac{2}{3}$ length of ventral, extending beyond base of latter. Caudal with rounded lobes. Caudal peduncle $2\frac{1}{2}$ as long as deep, $\frac{2}{3}$ length of head. 50-53 scales in the lateral line, $\frac{6-7}{17-18}$ in a transverse line on the body, $\frac{10}{10}$ in a transverse line between dorsal and anal, 16 round caudal peduncle. Brown.

Total length 90 millim.

Ogowe.

2. STOMATORHINUS MICROPS.

Stomatorhinus microps, Bouleng. Ann. Mus. Congo, Zool. i. 1898, p. 9, pl. iv. fig. 2.

Depth of body 4 to $4\frac{1}{2}$ times in total length, length of head 4. Head $1\frac{1}{4}$ to $1\frac{1}{3}$ as long as deep; snout rounded, $\frac{1}{4}$ to $\frac{2}{7}$ length of head; mouth small, its width $\frac{1}{6}$ to $\frac{1}{5}$ length of head; 7 teeth in the upper jaw, 8 in the lower; eye extremely small. Dorsal 18–20, about $\frac{1}{2}$ as long as its distance from head. Anal 20–22, nearer base of caudal than base of ventral. Pectoral obtusely pointed, $\frac{2}{3}$ length of head, $1\frac{2}{3}$ length of ventral, extending beyond base of latter. Caudal with rounded lobes. Caudal peduncle twice as long as deep, about $\frac{1}{2}$ length of head. 48–50 scales in the lateral line, $\frac{7-8}{14-15}$ in a transverse line on the body, $\frac{8}{9-10}$ in a transverse line between dorsal and anal, 16 round caudal peduncle. Colourless.

Total length 90 millim.

Lower Congo.

6. MYOMYRUS.

Myomyrus, Bouleng. Ann. Mus. Congo, Zool. i. 1898, p. 9.

5 or 6 conical teeth¹ in the upper jaw, 6 compressed teeth in the lower jaw, median pair very large and incisor-like; mouth inferior, anterior to the eyes. Nostrils close together, distant from the eye. Body short; ventrals nearer pectorals than anal. Dorsal much longer than anal. Vertebrae 50 (14+4+32).

1. MYOMYRUS MACRODON.

Myomyrus macrodon, Bouleng. l. c. p. 10, pl. vii. fig. 1.

Depth of body equal to length of head, $4\frac{1}{3}$ to $4\frac{2}{3}$ times in total length. Head $1\frac{1}{5}$ to $1\frac{1}{4}$ as long as deep, with slightly concave upper profile; snout short, $\frac{2}{7}$ length of head, strongly projecting beyond the mouth; mouth small, its width $\frac{1}{6}$ length of head; nostrils below level of eye, nearer end of snout than eye; eye very small, $\frac{1}{4}$ interorbital width. Dorsal 41–42, slightly longer than its distance from end of snout. Anal 30, originating below 13th ray of dorsal, a little nearer base of caudal than base of ventral. Pectoral obtusely pointed, $\frac{2}{3}$ length of head, $1\frac{1}{3}$ length of ventral, reaching base of latter. Caudal scaled, with rounded lobes. Caudal peduncle 3 times as long as deep, $\frac{3}{5}$ length of head. 88–90 scales in the lateral line, $\frac{19-20}{24-25}$ in a transverse line on the body, $\frac{11}{15}$ in a transverse line between dorsal and anal, 20 round caudal peduncle. Pale brownish above, whitish below.

Total length 240 millim.

Lower Congo.

¹ Through a sciagraph for which I am indebted to Messrs. Gardiner and Green, I have ascertained that the upper teeth are by no means so minute as they look in the undissected specimen, where nothing but their small points project from the thick lips.

7. GNATHONEMUS.

Mormyrops, part., Marcusen, Bull. Ac. St. Pétersb. xii. 1854, p. 14, and Mém. Ac. St. Pétersb. (7) vii. 1864, no. 4, p. 113.

Gnathonemus, Gill, Proc. Ac. Philad. 1862, p. 443; Bouleng. Ann. Mus. Congo, Zool. i. 1898, p. 2.

Campylomormyrus, Bleek. Versl. Ak. Amsterd. (2) viii. 1874, p. 367.

Teeth in the jaws small, conical, truncate, or notched, few (3-7 in the upper jaw, 4-10 in the lower); minute conical teeth on the parasphenoid and on the tongue; mouth terminal (not below the level of the lower border of the eye in the short-snouted forms). Nostrils moderately far apart, remote from the eye. Body moderately elongate; ventrals equally distant from pectorals and from anal, or nearer the former. Dorsal and anal not very unequal in length. Vertebrae 45-48 (12-13+4-8+27-30).

Synopsis of the Species.

I. Snout shorter than postocular part of head.

A. Anal originating more or less in advance of dorsal.

1. Dorsal 18-25.

a. Teeth notched.

D. 18-20; A. 26-28; no mental appendage or swelling; lat. l. 51-56; 12 scales round caudal peduncle.....

1. *niger* Gthr.

D. 22; A. 28; skin with a long pointed dermal appendage; lat. l. 58

2. *longibarbis* Hilg.

D. 20-25; A. 25-29; chin with a globular swelling; lat. l. 43-49; 8 scales round caudal peduncle.....

3. *moorii* Gthr.

D. 22; A. 28; chin with a globular swelling; lat. l. 65; 12 scales round caudal peduncle

4. *livingstonii* Blgr.

D. 23; A. 34; chin with a globular swelling; lat. l. 58; 12 scales round caudal peduncle.....

5. *bentleyi* Blgr.

b. Teeth conical.

D. 23-24; A. 28-32; chin with a globular swelling; lat. l. 56-62; 14-16 scales round caudal peduncle.

6. *macrolepidotus* Ptrs.

2. Dorsal 26-33.

a. Teeth conical or truncate; a globular mental swelling.

D. 26-28; A. 32-35; lat. l. 70-86; 16 scales round caudal peduncle.....

7. *cyprinoides* L.

D. 26-28; A. 31-36; lat. l. 66-72; 12 scales round caudal peduncle.....

8. *senegalensis* Sldr.

D. 28-31; A. 37-40; lat. l. 70-80; 12 scales round caudal peduncle.....

9. *stanleyanus* Blgr.

b. Teeth notched.

D. 29-33; A. 36; chin with a globular swelling; lat. l. 84-85; 12 scales round caudal peduncle.

10. *mento* Blgr.

D. 29-30; A. 36-38; chin with a short dermal appendage, as long as the eye; lat. l. 78-80; 12 scales round caudal peduncle

11. *monteiri* Gthr.

D. 27-29; A. 34-38; chin with a long dermal appendage, a little longer than the snout; lat. l. 63-70; 8 scales round caudal peduncle.....

12. *petersii* Gthr.

- B. Dorsal originating a little in advance of anal.
- D. 28; A. 30; chin with a globular swelling; lat. l. 55; 12 scales round caudal peduncle..... 13. *ussleri* Gthr.
- D. 35; A. 31; chin with a short dermal appendage; lat. l. 80; 8 scales round caudal peduncle..... 14. *greshoffi* Schilth.
- II. Snout much longer than postocular part of head, tubiform; lower jaw with a dermal appendage.
- A. 12 scales round caudal peduncle.
- D. 26-30; A. 30-33; length of snout 4-5 times its least depth; mental appendage about as long as the eye 15. *tamandua* Gthr.
- D. 34; A. 35; length of snout 3 times its least depth; mental appendage $\frac{3}{4}$ length of snout..... 16. *mirus* Blgr.
- D. 33; A. 34-36; snout directed downwards at right angles to the outline of the pectoral region, its length 3-4 times its least depth; mental appendage not longer than eye 17. *elephas* Blgr.
- B. 16-18 scales round caudal peduncle; mental appendage short.
- D. 28-31; A. 31-35; snout strongly curved, its length $5\frac{1}{2}$ -7 times its least depth..... 18. *rhynchophorus* Blgr.
- D. 32; A. 36; snout strongly curved, its length 12 times its least depth..... 19. *curvirostris* Blgr.
- D. 32; A. 36; snout feebly curved, its length 20 times its least depth 20. *numenius* Blgr.

1. GNATHONEMUS NIGER.

Mormyrus niger, Günth. Cat. vi. p. 219 (1866).

Gnathonemus niger, Bouleng. Ann. Mus. Congo, Zool. i. 1898, p. 10.

Depth of body $3\frac{1}{2}$ to $3\frac{2}{3}$ times in total length, length of head 5. Head as long as deep, with convex upper profile; snout very short, $\frac{1}{5}$ length of head; mouth on a level with the lower border of the eye; no mental swelling; teeth small, notched, 5 in the upper jaw, 8 in the lower; eye rather small, slightly shorter than the snout, $\frac{1}{2}$ to $\frac{3}{5}$ interorbital width. Dorsal 18-20, originating above 9th or 10th ray of anal, its length 2 to $2\frac{1}{2}$ times in its distance from head. Anal 26-28, nearer base of caudal than base of ventral. Pectoral a little longer than head, at least twice as long as ventral, extending almost to extremity of latter. Caudal densely scaled in its basal third, with obtusely pointed lobes. Caudal peduncle twice as long as deep, $\frac{3}{4}$ to $\frac{4}{5}$ length of head. 51-56 scales in the lateral line, $\frac{8-9}{14-15}$ in a transverse line on the body, $\frac{8-9}{8-9}$ in a transverse line between dorsal and anal, 12 round caudal peduncle. Blackish brown.

Total length 115 millim.

Gambia.

2. GNATHONEMUS LONGIBARBIS.

Mormyrus longibarbis, Hilgend. Sitzb. Ges. nat. Fr. Berl. 1888, p. 78.

Gnathonemus longibarbis, Bouleng. Ann. Mus. Congo, Zool. i. 1898, p. 10.

Chin with a very long pointed dermal appendage, its length nearly equal to that of the snout. Dorsal 22; anal 28; pectoral $\frac{2}{3}$ length of head. Lat. l. 58; l. tr. $\frac{11}{11}$.

Victoria Nyanza.—Type in Berlin Museum; insufficiently described.

3. GNATHONEMUS MOORII.

? *Mormyrus*, sp. n., Heuglin, Sitzb. Ak. Wien, ix. 1852, p. 920, pl. lx. fig. 1.

? *Petrocephalus pictus*, Marcusen, Mém. Ac. St. Pétersb. (7) vii. 1864, p. 153.

Mormyrus moorii, Günth. Ann. & Mag. N. H. (3) xx. 1867, p. 116.

Mormyrus lepturus, Günth. Proc. Zool. Soc. 1871, p. 670, pl. lxxix. fig. B, and Ann. & Mag. Nat. Hist. (6) xvii. 1896, p. 280.

Mormyrus grandisquamis, Peters, Mon. Berl. Ac. 1876, p. 250, pl. —. fig. 3; Schilth. Tijdschr. Nederl. Dierk. Ver. (2) iii. 1891, p. 84.

Gnathonemus moorii, Bouleng. Ann. Mus. Congo, Zool. i. 1898 p. 10.

Depth of body $3\frac{1}{5}$ to $3\frac{1}{2}$ times in total length, length of head 4 to $4\frac{2}{3}$. Head as long as deep or slightly longer than deep, with curved upper profile; snout short, about $\frac{1}{4}$ length of head; mouth on a level with the lower border of the eye; a dermal swelling on the chin; teeth small, notched, 5 in the upper jaw, 6 in the lower; eye moderate, $\frac{2}{3}$ to $\frac{3}{4}$ length of snout, about $\frac{1}{2}$ interorbital width. Dorsal 20–25, originating above 4th to 6th ray of anal, its length 2 to $2\frac{1}{3}$ times in its distance from the head. Anal 25–29, equally distant from base of ventral and base of caudal, or nearer the latter. Pectoral as long as head, twice as long as ventral, extending beyond base of latter. Caudal densely scaled in its anterior third, with pointed lobes. Caudal peduncle $2\frac{1}{2}$ to 3 times as long as deep, a little shorter than head. 43–49 scales in the lateral line, $\frac{10-11}{13-15}$ in a transverse line on the body, $\frac{7}{7}$ in a transverse line between dorsal and anal, 8 round caudal peduncle. Brownish, with a dark brown vertical band from the anterior rays of the dorsal to the anterior rays of the anal.

Total length 150 millim.

Gaboon, Ogowe, Congo; Upper Nile (?).

4. GNATHONEMUS LIVINGSTONII, sp. n.

Depth of body $3\frac{2}{3}$ times in total length, length of head $4\frac{1}{2}$. Head nearly as long as deep, with curved upper profile; snout $\frac{2}{7}$ length of head; mouth small; chin with a globular dermal appendage; teeth small, bicuspid, 5 in the upper jaw, 6 in the lower; eye small, $\frac{1}{2}$ length of snout, $\frac{2}{5}$ interorbital width. Dorsal 22, originating above 10th ray of anal, its length $2\frac{1}{2}$ in its distance

from head. Anal 28, equally distant from base of ventral and from base of caudal. Pectoral obtusely pointed, $\frac{3}{4}$ length of head, twice length of ventral, reaching a little beyond base of latter. Caudal with obtusely pointed lobes. Caudal peduncle 3 times as long as deep, a little shorter than head. 65 scales in the lateral line, $\frac{15}{20}$ in a transverse line on the body, $\frac{11}{11}$ in a transverse line between dorsal and anal, 12 round caudal peduncle. Silvery, brownish on the back; a dark brown vertical bar on the body below origin of dorsal.

Total length 83 millim.

R. Rovuma. A single young specimen collected by C. Livingstone.

5. GNATHONEMUS BENTLEYI.

Mormyrus bentleyi, Bouleng. Ann. & Mag. Nat. Hist. (6) xx. 1897, p. 426.

Gnathonemus bentleyi, Bouleng. Ann. Mus. Congo, Zool. i. 1898, p. 10.

Depth of body equal to length of head, 5 times in total length. Head $1\frac{1}{4}$ as long as deep, upper profile slightly concave above the eye; snout $\frac{1}{4}$ length of head; mouth on a line with lower border of eye, its width $\frac{1}{5}$ length of head; teeth moderately large, notched, 7 in the upper jaw, 10 in the lower; chin strongly swollen; eye moderate, $\frac{1}{2}$ length of snout, $\frac{2}{5}$ interorbital width. Dorsal 23, originating above 5th ray of anal, its length twice in its distance from head. Anal 34, nearer base of caudal than base of ventral. Pectoral pointed, almost as long as head, nearly twice as long as ventral, extending beyond base of latter. Caudal densely scaled, with pointed lobes. Caudal peduncle 3 times as long as deep, almost as long as head. 58 scales in the lateral line, $\frac{9}{15}$ in a transverse line on the body, $\frac{8}{10}$ in a transverse line between dorsal and anal, 12 round caudal peduncle. Dark olive.

Total length 270 millim.

Upper Congo.

6. GNATHONEMUS MACROLEPIDOTUS.

Mormyrus macrolepidotus, Peters, Mon. Berl. Ac. 1852, p. 275; Günth. Cat. vi. p. 219 (1866); Peters, Reise n. Mossamb. iv. p. 79, pl. xv. fig. 1 (1868).

Mormyrops macrolepidotus, Marcusen, Mém. Ac. St. Pétersb. (7) vii. 1864, no. 4, p. 142.

Gnathonemus macrolepidotus, Bouleng. Ann. Mus. Congo, Zool. i. 1898, p. 10.

Depth of body $3\frac{1}{2}$ to 4 times in total length, length of head $4\frac{1}{2}$ to 5. Head nearly as long as deep, with curved upper profile; snout $\frac{1}{4}$ length of head; chin with a globular dermal appendage; teeth minute, conical, 3 or 5 in the upper jaw, 6 in the lower; eye moderate, $\frac{2}{3}$ to $\frac{3}{4}$ length of snout, $\frac{1}{2}$ interorbital

width. Dorsal 23-24, originating above 5th to 8th ray of anal, its length about $2\frac{1}{2}$ in its distance from head. Anal 28-32, a little nearer base of caudal than base of ventral. Pectoral obtusely pointed, shorter than head, reaching base of ventral or a little beyond. Caudal with obtusely pointed lobes. Caudal peduncle 3 times as long as deep, nearly as long as head. 58-68 scales in the lateral line, $\frac{10-12}{17-19}$ in a transverse line on the body, $\frac{8-12}{8-12}$ in a transverse series between dorsal and anal, 14 or 16 round caudal peduncle. Silvery, brownish on the back, sometimes with brown blotches.

Reaches a length of 320 millim.

Zambezi.

7. GNATHONEMUS CYPRINOIDES.

Mormyrus cyprinoides, Linn. Mus. Ad. Frid. ii. p. 109 (1764), and S. N. i. p. 522 (1766); Cuv. & Val. xix. p. 265 (1849); Günth. Cat. vi. p. 218 (1866).

Mormyrus salahie, Lacép. Poiss. v. p. 619 (1803).

Mormyrus labiatus, Geoffr. Descr. Égypte, Poiss. p. 275, pl. vii. fig. 1 (1829); Rüpp. Fortsetz. Besch. n. Fische Nil, p. 9, pl. ii. fig. 2 (1832).

Mormyrus elongatus, Rüpp. l. c. fig. 1.

Mormyrus abbreviatus, Cuv. & Val. t. c. p. 270.

Mormyrops cyprinoides, Marcusen, Bull. Ac. St. Pétersb. xii. 1854, p. 14.

Mormyrops elongatus, Marcusen, l. c.

Mormyrus abbreviatus, Marcusen, l. c.

Mormyrops labiatus, Marcusen, Mém. Ac. St. Pétersb. (7) vii. 1864, no. 4, p. 137.

Gnathonemus cyprinoides, Bouleng. Ann. Mus. Congo, Zool. i. 1898, p. 11.

Depth of body $3\frac{1}{2}$ to 5 times in total length, length of head $4\frac{3}{4}$ to $5\frac{1}{2}$. Head slightly longer than deep, with curved upper profile; snout about $\frac{1}{4}$ length of head; mouth small, on a line with lower border of eye; chin with a globular dermal appendage; teeth minute, conical, 5 in the upper jaw, 6 in the lower; eye moderate, $\frac{1}{2}$ to $\frac{2}{3}$ length of snout, $\frac{2}{5}$ to $\frac{1}{2}$ interorbital width. Dorsal 26-28, originating above 6th to 9th ray of anal, its length 2 to $2\frac{1}{2}$ in its distance from head. Anal 32-35¹, equally distant between base of ventral and base of caudal, or a little nearer the former. Pectoral pointed, as long as head or a little shorter, twice as long as ventral, reaching base of latter or beyond. Caudal scaled in its basal half, with pointed lobes. Caudal peduncle $2\frac{1}{2}$ to 3 times as long as deep, as long as head or a little shorter. 70-86 scales in the lateral line, $\frac{15-20}{22-24}$ in a transverse series on the body, $\frac{12-15}{12-15}$ in a transverse series between dorsal and anal, 16 round

¹ The posterior rays produced in the males (*M. elongatus* Rüpp.).

caudal peduncle. Silvery, brownish above, uniform or with dark blotches.

Total length 270 millim.

Nile, Congo.

8. GNATHONEMUS SENEGALENSIS.

Mormyrus senegalensis, Steind. Sitzb. Ak. Wien, lxi. i. 1870, p. 551, pl. iv. fig. 1.

Gnathonemus senegalensis, Bouleng. Ann. Mus. Congo, Zool. i. 1898, p. 11.

Depth of body 3 to $3\frac{2}{3}$ times in total length, length of head $4\frac{2}{3}$ to $4\frac{3}{4}$. Head nearly as long as deep, with curved upper profile; snout less than $\frac{1}{4}$ length of head; mouth small, on a line with lower border of eye; chin with a globular dermal appendage; teeth small, conical, 5 in the upper jaw, 6 in the lower; eye moderate, $\frac{2}{3}$ length of snout. Dorsal 26–28, originating above 6th ray of anal, its length twice in its distance from head. Anal 31–36, nearer base of caudal than base of ventral. Pectoral pointed, a little shorter than head, twice as long as ventral, reaching base of latter. Caudal scaled in its basal half, with pointed lobes. Caudal peduncle 3 times as long as deep, $\frac{3}{4}$ length of head. 66–72 scales in the lateral line, $\frac{14}{15}$ in a transverse line between dorsal and anal, 12 round caudal peduncle. Steel-blue above, silvery white below.

Total length 200 millim.

Senegal.

9. GNATHONEMUS STANLEYANUS.

Mormyrus stanleyanus, Bouleng. Ann. & Mag. N. H. (6) xx. 1897, p. 426.

Gnathonemus stanleyanus, Bouleng. Ann. Mus. Congo, Zool. i. 1898, pl. 11.

Depth of body $3\frac{1}{4}$ to $3\frac{3}{4}$ times in total length, length of head $4\frac{1}{2}$ to 5. Head little longer than deep, upper profile slightly convex; snout $\frac{1}{3}$ length of head; mouth small, on a line with centre of eye, its width $\frac{1}{5}$ length of head; a globular dermal swelling on the chin; teeth small, conical or truncate, 7 in the upper jaw, 6 in the lower; eye moderate, $\frac{2}{3}$ length of snout, $\frac{3}{5}$ to $\frac{3}{4}$ interorbital width. Dorsal 28–31, originating above 9th–11th ray of anal, its length twice in its distance from head. Anal 37–40, nearer base of caudal than base of ventral. Pectoral pointed, $\frac{4}{5}$ length of head, twice as long as ventral, extending beyond base of latter. Caudal scaled, with obtusely pointed lobes. Caudal peduncle 3 times as long as deep, $\frac{3}{4}$ length of head. 70–80 scales in the lateral line, $\frac{15-18}{20-22}$ in a transverse line on the body, $\frac{15-16}{14-15}$ in a transverse line between dorsal and anal, 12 round caudal peduncle. Silvery, dark grey on the back.

Total length 220 millim.

Congo.—The type-specimen came from Stanley Falls. I have examined other specimens from Matadi and Upoto.

10. GNATHONEMUS MENTO.

Mormyrus mento, Bouleng. Ann. & Mag. N. H. (6) vi. 1890, p. 193; Steind. Notes Leyd. Mus. xvi. 1894, p. 72.

Gnathonemus mento, Bouleng. Ann. Mus. Congo, Zool. i. 1898, p. 11.

Depth of body $3\frac{1}{2}$ times in total length, length of head 5. Head as long as deep, with strongly curved upper profile; snout $\frac{8}{10}$ length of head; mouth small, on a line with lower border of eye; a strong mental swelling; teeth small, notched, 5 in the upper jaw, 6 in the lower; eye moderate, $\frac{3}{4}$ length of snout, about $\frac{2}{3}$ interorbital width. Dorsal 29-33, originating above 9th ray of anal, its length twice in its distance from head. Anal 36, equally distant from base of ventral and from base of caudal. Pectoral a little shorter than head, $1\frac{2}{3}$ length of ventral, extending a little beyond base of latter. Caudal scaled in its basal half, with pointed lobes. Caudal peduncle nearly 4 times as long as deep, as long as head. 84-85 scales in the lateral line, $\frac{14}{24}$ in a transverse line on the body, $\frac{14}{12}$ in a transverse line between dorsal and anal, 12 round caudal peduncle. Silvery, with fine brown dots, which are very crowded on the head and the dorsal and ventral lines.

Total length 190 millim.

Gaboon, Liberia.

11. GNATHONEMUS MONTEIRI.

Mormyrus monteiri, Günth. Ann. & Mag. N. H. (4) xii. 1873, p. 144.

Gnathonemus monteiri, Bouleng. Ann. Mus. Congo, Zool. i. 1898, p. 11.

Depth of body $3\frac{1}{4}$ to 4 times in total length, length of head $4\frac{1}{3}$ to $4\frac{2}{3}$. Head $1\frac{1}{4}$ to $1\frac{1}{3}$ as long as deep, upper profile descending in a straight or slightly convex line; snout $\frac{1}{3}$ length of head; lower jaw with a roundish, depressed dermal appendage about as long as the eye; teeth very small, notched, 5 in the upper jaw, 6 in the lower; eye moderate, $\frac{1}{2}$ to $\frac{2}{3}$ length of snout, $\frac{2}{3}$ to $\frac{3}{4}$ interorbital width. Dorsal 29-30, originating above 10th to 12th ray of anal, its length twice in its distance from head. Anal 36-38, equally distant from base of ventral and base of caudal. Pectoral pointed, little shorter than head, more than twice as long as ventral, extending beyond base of latter. Caudal scaled, with pointed lobes. Caudal peduncle 3 times as long as deep, $\frac{3}{4}$ to $\frac{4}{5}$ length of head. 78-80 scales in the lateral line, $\frac{16-19}{21-23}$ in a transverse line on the body, $\frac{13-15}{10-14}$ in a transverse line between dorsal and anal, 12 round caudal peduncle. Uniform silvery.

Total length 185 millim.

Angola.

12. GNATHONEMUS PETERSII.

Mormyrus petersii, Günth. Arch. f. Nat. 1862, p. 64; Proc. Zool. Soc. 1864, p. 22, pl. ii. fig. 2; Cat. vi. p. 218 (1866); and in Petherick's Trav. ii. p. 256 (1869).

Gnathonemus petersii, Gill, Proc. Ac. Philad. 1862, p. 444.

Depth of body $3\frac{3}{4}$ to $4\frac{1}{4}$ times in total length, length of head $4\frac{1}{4}$ to $4\frac{2}{3}$. Head $1\frac{1}{3}$ to $1\frac{1}{2}$ as long as deep, upper profile descending in a straight or slightly convex line; snout $\frac{2}{5}$ length of head; lower jaw with a cylindrical, tapering dermal appendage, a little longer than the snout and directed forwards; teeth very small, notched, 5 in the upper jaw, 6 in the lower; eye moderate, about $\frac{1}{2}$ length of snout, $\frac{3}{5}$ to $\frac{1}{2}$ interorbital width. Dorsal 27-29, originating above 10th to 12th ray of anal, its length nearly twice in its distance from head. Anal 34-36, nearer base of caudal than base of ventral. Pectoral pointed, almost as long as head, twice as long as ventral, extending beyond base of latter. Caudal scaled, with pointed lobes. Caudal peduncle 3 times as long as deep, $\frac{2}{3}$ to $\frac{3}{4}$ length of head. 63-70 scales in the lateral line, $\frac{12-13}{15-18}$ in a transverse line on the body, $\frac{10-11}{10-11}$ in a transverse line between dorsal and anal, 8 round caudal peduncle. Dark brown, with two lighter vertical bars between dorsal and anal.

Total length 230 millim.

Old Calabar, Congo, White Nile.

13. GNATHONEMUS USSHERI.

Mormyrus ussheri, Günth. Ann. & Mag. N. H. (3) xx. 1867, p. 116; Steind. Notes Leyd. Mus. xvi. 1894, p. 71.

Gnathonemus ussheri, Bouleng. Ann. Mus. Congo, Zool. i. 1898, p. 11.

Depth of body $3\frac{1}{3}$ times in total length, length of head $4\frac{2}{3}$. Head a little longer than deep, with curved upper profile; snout short, $\frac{2}{7}$ length of head; mouth small, on a level with lower border of eye; a globular ventral swelling; teeth small, notched, 5 in the upper jaw, 6 in the lower; eye moderate, $\frac{2}{3}$ length of snout or interorbital width. Dorsal 27-28, originating very slightly in advance of anal, its length a little less than twice in its distance from the head. Anal 30-32, equally distant from base of ventral and from base of caudal. Pectoral pointed, as long as head, twice as long as ventral, extending beyond base of latter. Caudal scaled in its anterior half, with pointed lobes. Caudal peduncle twice as long as deep, slightly shorter than head. 55-57 scales in the lateral line, $\frac{10}{15}$ in a transverse series on the body, $\frac{9}{9}$ in a transverse series between dorsal and anal, 12 round caudal peduncle. Brown.

Total length 170 millim.

Gold Coast, Liberia.

14. GNATHONEMUS GRESHOFFI.

Mormyrus greshoffi, Schilthuis, Tijdschr. Nederl. Dierk. Ver. (2) iii. 1891, p. 90, pl. vi. fig. 3.

Gnathonemus greshoffi, Bouleng. Ann. Mus. Congo, Zool. i. 1898, p. 11.

Depth of body $3\frac{1}{2}$ times in total length, length of head $4\frac{1}{2}$. Head a little longer than deep, upper profile descending in a curve; snout $\frac{1}{4}$ length of head; lower jaw with a dermal appendage half the length of the snout; teeth very small, 3 in the upper jaw, 2 (?) in the lower; eye large, situated in the anterior half of the head, its diameter a little greater than the length of the snout or the interorbital width. Dorsal 35, originating a little in advance of the anal, its length twice in the distance from end of snout. Anal 31, nearer base of ventral than base of caudal. Pectoral pointed, almost as long as head, twice as long as ventral, extending beyond base of latter. Caudal rather small, with pointed lobes. Caudal peduncle 5 times as long as deep, as long as head. 80 scales in the lateral line, 8 round caudal peduncle. Silvery.

Total length 108 millim.

Lower Congo.

15. GNATHONEMUS TAMANDUA.

Mormyrus tamandua, Günth. Proc. Zool. Soc. 1864, p. 22, pl. ii. fig. 1, and Cat. vi. p. 217 (1866).

Gnathonemus tamandua, Bouleng. Ann. Mus. Congo, Zool. i. 1898, p. 11.

Depth of body 4 to $4\frac{1}{2}$ times in total length, length of head 4 to $4\frac{1}{2}$. Upper profile of head descending in a strong curve; snout much prolonged, tubiform, strongly compressed, curved downwards, its length $1\frac{2}{3}$ to 2 postocular part of head, and 4 to 5 times its least depth, which nearly equals diameter of eye; latter $\frac{2}{3}$ interorbital width; lower jaw with a compressed dermal appendage about as long as the eye; mouth very small; teeth very small, conical, 3 in upper jaw, 4 in the lower. Dorsal 26-30, originating above 6th to 8th ray of anal, its length $1\frac{1}{2}$ to $1\frac{4}{5}$ in its distance from head. Anal 30-33, nearer base of caudal than base of ventral. Pectoral obtusely pointed, $\frac{3}{5}$ to $\frac{2}{3}$ length of head, ventral $\frac{1}{3}$ to $\frac{2}{5}$; pectoral extending beyond base of ventral. Caudal densely scaled, with pointed lobes. Caudal peduncle $3\frac{1}{2}$ times as long as deep, $\frac{2}{3}$ to $\frac{3}{4}$ length of head. 70-80 scales in the lateral line, $\frac{12-18}{19-21}$ in a transverse line on the body, $\frac{14-15}{12-15}$ in a transverse line between dorsal and anal, 12 round caudal peduncle. Brownish above.

Total length 230 millim.

Congo, Old Calabar.

16. GNATHONEMUS MIRUS.

Gnathonemus mirus, Bouleng. Ann. Mus. Congo, Zool. i. 1898, p. 11, pl. iii. fig. 2.

Depth of body $3\frac{1}{2}$ times in total length, length of head 4. Upper profile of head descending in a strong curve; snout much prolonged, tubiform, strongly compressed, curved downwards, its length twice postocular part of head, and 3 times its least depth, which is twice diameter of eye; latter $\frac{2}{3}$ interorbital width; lower jaw with a long, compressed, attenuate dermal appendage, measuring nearly $\frac{3}{4}$ length of snout; mouth very small; teeth very small, conical, 3 in the upper jaw, 4 in the lower. Dorsal 34, originating above 4th ray of anal, its length $1\frac{1}{2}$ in its distance from head. Anal 35, equally distant from base of ventral and base of caudal. Pectoral pointed, about $\frac{2}{3}$ length of head, extending to middle of ventral, which is only $\frac{1}{2}$ as long. Caudal scaled, with obtusely pointed lobes. Caudal peduncle 3 times as long as deep, $\frac{2}{3}$ length of head. 78 scales in the lateral line, $\frac{17}{25}$ in a transverse line on the body, $\frac{20}{18}$ in a transverse line between dorsal and anal, 12 round caudal peduncle. Brownish above.

Total length 320 millim.

Upper Congo.

17. GNATHONEMUS ELEPHAS.

Gnathonemus elephas, Bouleng. Ann. Mus. Congo, Zool. i. 1898, p. 12, pl. v. fig. 1.

Depth of body $3\frac{2}{3}$ to $3\frac{3}{4}$ times in total length, length of head 4 to $4\frac{1}{4}$. Upper profile of head descending in a very strong curve; snout much prolonged, tubiform, strongly compressed, directed almost straight downwards at right angles to the outline of the pectoral region, its length nearly twice postocular part of head, 3 to 4 times its least depth, which is $1\frac{1}{2}$ diameter of eye; latter $\frac{2}{3}$ interorbital width; lower jaw with a short, wart-like, cylindrical, dermal appendage as long as or a little shorter than diameter of eye; mouth very small; teeth very small, conical, 3 in the upper jaw, 4 in the lower. Dorsal 33, originating above 5th ray of anal, its length $1\frac{1}{3}$ to $1\frac{2}{5}$ its distance from head. Anal 34-36, equally distant from base of ventral and base of caudal. Pectoral pointed, little shorter than head, extending to middle or second third of ventral, and twice as long as the latter. Caudal scaled, with pointed lobes. Caudal peduncle 3 times as long as deep, as long as head or a little shorter. 80 scales in the lateral line, $\frac{15}{23}$ in a transverse line on the body, $\frac{16-18}{15-16}$ in a transverse line between dorsal and anal, 12 round caudal peduncle. Brownish above.

Total length 400 millim.

Upper Congo.

18. GNATHONEMUS RHYNCHOPHORUS. (Plate LI.)

Gnathonemus rhynchophorus, Bouleng. Ann. Mus. Congo, Zool. i. 1898, p. 13, pl. v. fig. 2.



Swan Electric Engraving Co.

GNATHONEMUS RHYNCOPHORUS.

Green & Gardiner, Sciagraph.



Depth of body equal to length of head, $3\frac{1}{2}$ to 4 times in total length. Upper profile of head descending in a strong curve; snout much prolonged, tubiform, strongly compressed, curved downwards, its length 2 to $2\frac{1}{3}$ postocular part of head, and $5\frac{1}{2}$ to 7 times its least depth, which nearly equals diameter of eye; latter $\frac{2}{3}$ interorbital width; lower jaw with a compressed dermal appendage about as long as the eye; mouth very small; teeth very small, conical, 5 in the upper jaw, 4 in the lower. Dorsal 28-31, originating above 6th or 7th ray of anal, its length $1\frac{1}{2}$ to $1\frac{3}{4}$ in its distance from head. Anal 31-35, nearly equally distant from base of ventral and base of caudal. Pectoral obtusely pointed, $\frac{1}{2}$ length of head, ventral $\frac{1}{3}$ or rather less; pectoral extending beyond base of ventral. Caudal scaled, with pointed lobes. Caudal peduncle 3 to $3\frac{1}{2}$ times as long as deep, $\frac{1}{2}$ to $\frac{2}{3}$ length of head. 75-85 scales in the lateral line, $\frac{18-21}{31-32}$ in a transverse line on the body, $\frac{20-23}{20-23}$ in a transverse line between dorsal and anal, 18 round caudal peduncle. Brownish, with a rather indistinct darker vertical band between dorsal and anal.

Total length 380 millim.

Upper Congo.

19. GNATHONEMUS CURVIROSTRIS.

Gnathonemus curvirostris, Bouleng. Ann. Mus. Congo, Zool. i. 1898, p. 13, pl. vi. fig. 1.

Depth of body $4\frac{2}{3}$ times in total length, length of head $3\frac{1}{2}$. Upper profile of head descending in a strong curve; snout much prolonged, tubiform, strongly compressed, curved downwards, its length $3\frac{1}{2}$ postocular part of head, and 12 times its least depth, which a little exceeds diameter of eye; latter slightly more than $\frac{1}{2}$ interorbital width; lower jaw with a compressed dermal appendage $1\frac{1}{2}$ diameter of eye; mouth very small; teeth very small, conical, 3 in the upper jaw, 4 in the lower. Dorsal 32, originating above 10th ray of anal, its length $1\frac{1}{2}$ in its distance from head. Anal 36, equally distant from base of ventral and base of caudal. Pectoral pointed, $\frac{1}{2}$ length of head, ventral nearly $\frac{1}{4}$, pectoral extending beyond base of ventral. Caudal scaled, with pointed lobes. Caudal peduncle 4 times as long as deep, more than $\frac{1}{2}$ length of head. 90 scales in the lateral line, $\frac{18}{22}$ in a transverse line on the body, $\frac{18}{17}$ in a transverse line between dorsal and anal, 16 round caudal peduncle. Pale brownish above, whitish below.

Total length 370 millim.

Lower Congo.

20. GNATHONEMUS NUMENIUS.

Gnathonemus numenius, Bouleng. Ann. Mus. Congo, Zool. i. 1898, p. 14, pl. vi. fig. 2.

Depth of body $4\frac{2}{3}$ to 5 times in total length, length of head $2\frac{2}{3}$ to $2\frac{1}{2}$. Upper profile of head convex; snout produced in an

extremely long, compressed tube, feebly curved downwards, its length 5 to $5\frac{1}{2}$ times postocular part of head, and 20 times its least depth, which equals diameter of eye; latter $\frac{2}{3}$ interorbital width; lower jaw with a compressed dermal appendage nearly as long as the eye; mouth very small; teeth very small, 7 in the upper jaw, 4 or 6 in the lower. Dorsal 32, originating above 8th or 9th ray of anal, its length $1\frac{3}{4}$ in its distance from head. Anal 36, equally distant from base of ventral and base of caudal. Pectoral pointed, $\frac{1}{3}$ length of head, almost twice as long as ventral, and extending almost to the extremity of the latter. Caudal scaled, with obtusely pointed lobes. Caudal peduncle 3 times as long as deep, not quite $\frac{1}{3}$ length of head; 79–81 scales in the lateral line, $\frac{18}{24-25}$ in a transverse line on the body, $\frac{19}{17-18}$ in a transverse line between dorsal and anal, 16 round caudal peduncle. Pale brownish above, whitish beneath. Total length 610 millim.

Upper Congo.

8. MORMYRUS.

Mormyrus, part., Linn. Syst. Nat. i. p. 522 (1766), et auctor.

Scrophicephalus, Swains. Nat. Hist. Fish. ii. p. 187 (1839).

Mormyrus, *Mormyrodes*, Gill, Proc. Ac. Philad. 1864, p. 139.

Solenomormyrus, Bleek. Versl. Ak. Amsterd. (2) viii. 1874, p. 368.

Mormyrus, Bouleng. Ann. Mus. Congo, i. 1898, p. 2.

Teeth in the jaws small, notched, few (5–8 in the upper jaw, 8–12 in the lower); minute conical teeth on the parasphenoid and on the tongue; mouth terminal. Nostrils moderately far apart, remote from the eye. Body moderately elongate; ventrals equally distant from pectorals and from anal, or nearer the former. Dorsal much elongate, at least $2\frac{2}{3}$ as long as anal. Vertebrae 49–54 (12–13 + 7–10 + 30–31).

Synopsis of the Species.

I. Snout not more than $\frac{1}{3}$ length of head.

A. Dorsal originating in advance of base of ventral; pectoral rounded.

D. 70; A. 18; caudal peduncle twice as long as deep, $\frac{1}{2}$ length of head; pectoral $\frac{1}{2}$ length of head.....

1. *hasselquisti* Geoffr.

D. 62–66; A. 18–20; caudal peduncle twice as long as deep, nearly $\frac{1}{2}$ length of head; pectoral $\frac{2}{3}$ length of head.....

2. *anchietæ* Guim.

D. 70; A. 20; caudal peduncle $1\frac{1}{2}$ as long as deep, $\frac{2}{3}$ length of head; pectoral a little more than $\frac{1}{2}$ length of head.....

3. *guentheri* Blgr.

B. Dorsal originating above base of ventral; pectoral pointed, at least $\frac{2}{3}$ length of head; caudal peduncle $2\frac{1}{2}$ as long as deep, $\frac{3}{4}$ – $\frac{2}{3}$ length of head.

D. 65; A. 21; eye nearly as long as snout.....

4. *macrophthalmus* Gthr.

D. 53; A. 23; eye $\frac{1}{2}$ length of snout.....

5. *ovis* Blgr.

II. Snout at least $\frac{2}{3}$ length of head.

A. Dorsal originating above or in advance of base of ventral.

1. Caudal peduncle $1\frac{3}{4}$ to $2\frac{1}{2}$ times as long as deep, at least nearly $\frac{1}{2}$ length of head.

a. Dorsal 80-87; anal 17-20.

a. Pectoral pointed, more than $\frac{1}{2}$ length of head.

Length of head not greater than depth of body; upper profile of head a continuous descending straight line or feeble curve; 26-30 scales round caudal peduncle, which is twice as long as deep and $\frac{1}{2}$ length of head

6. *caschive* Hasselq.

Length of head greater than depth of body; snout with slightly concave upper profile

7. *niloticus* Bl. Schn.

Length of head not greater than depth of body, upper profile a continuous descending curve; caudal peduncle more than twice as long as deep.

8. *jubelini* C. & V.

β. Pectoral rounded, $\frac{1}{2}$ length of head; upper profile of head descending in a straight line

9. *rume* C. & V.

b. Dorsal 58-78.

D. 71-78, 5-5 $\frac{1}{2}$ times as long as anal; A. 18-20; pectoral pointed, $\frac{2}{3}$ - $\frac{2}{3}$ length of head; 22-26 scales round caudal peduncle

10. *longirostris* Ptrs.

D. 58-66, 4-4 $\frac{1}{2}$ times as long as anal; A. 18-21; pectoral pointed, $\frac{2}{3}$ - $\frac{2}{3}$ length of head; 26-28 scales round caudal peduncle

11. *kannume* Forsk.

D. 62, 3 times as long as anal; A. 23; pectoral rounded, hardly $\frac{1}{2}$ length of head; 12 scales round caudal peduncle

12. *caballus* Blgr.

2. Caudal peduncle $1\frac{1}{2}$ as long as deep, $\frac{1}{3}$ length of head; D. 75, nearly 5 times as long as anal; A. 19; pectoral pointed, nearly $\frac{1}{2}$ length of head; 18 scales round caudal peduncle

13. *proboscirostris* Blgr.

B. Dorsal 60, originating further back than ventral; anal 20

14. *tenuirostris* Ptrs.

1. MORMYRUS HASSELQUISTI.

Mormyrus herse (non Sonnini), Lacép. Hist. Poiss. v. p. 620 (1803).

Mormyrus caschive (non Hasselq.), Geoffr. Descr. Égypte, Poiss. p. 273, pl. vi. fig. 2 (1829).

Mormyrus hasselquistii, Cuv. & Val. xix. p. 253 (1846); Marcusen, Mém. Ac. St. Pétersb. (7) vii. 1864, no. 4, p. 130.

Depth of body nearly equal to length of head, 4 times in total length. Head $1\frac{2}{3}$ as long as deep, with curved upper profile; snout $\frac{1}{2}$ as long as postorbital part of head, projecting a little beyond the mouth; teeth small, notched; eye moderate, its diameter $2\frac{1}{2}$ in length of snout. Dorsal 70, originating in advance of ventral, twice as far from base of caudal as from end of snout, $5\frac{1}{2}$ times as long as anal. Anal 18, originating nearer base of caudal than base of pectoral. Pectoral rounded, $\frac{1}{2}$ length of head, ventral $\frac{1}{3}$.

Caudal with obtusely pointed lobes. Caudal peduncle twice as long as deep, nearly $\frac{1}{2}$ length of head. About 100 scales in the lateral line, 26 round caudal peduncle. Plumbeous or olive above, dorsal with oblique dark streaks.

Total length 350 millim.

Nile.—This description is drawn up from the figure in the 'Description de l'Égypte' and the account given by Valenciennes.

2. MORMYRUS ANCHIETÆ.

Mormyrus anchietæ, Guimaraes, Journ. Sc. Lisb. x. 1884, p. 4, pl. i. fig. 3.

Depth of body $4\frac{1}{2}$ to $5\frac{1}{2}$ times in total length, length of head 4 to $4\frac{1}{2}$. Head $1\frac{1}{2}$ as long as deep, with curved upper profile; snout about $\frac{1}{2}$ as long as postorbital part of head; chin swollen, rather prominent; teeth small, notched, 7 in the upper jaw, 10 in the lower; eye moderate, its diameter about $\frac{1}{3}$ length of snout. Dorsal 62–66, originating in advance of ventral, twice as far from end of snout as from extremity of caudal, 4 times as long as anal. Anal 18–20, originating nearer base of caudal than base of pectoral. Pectoral rounded, nearly $\frac{2}{3}$ length of head, ventral $\frac{2}{5}$. Caudal densely scaled, with pointed lobes. Caudal peduncle twice as long as deep, nearly $\frac{1}{2}$ length of head. 86 scales in the lateral line, 30 in a transverse series on the body, 20 or 22 (?) round caudal peduncle. Brownish above, silvery beneath; a whitish streak along the lateral line.

Total length 330 millim.

Cunene and Caconda, Angola.—Type in Lisbon Museum.

The insufficiently characterized *Mormyrus lacerdæ*, Castelnau, Poiss. Afr. Austr. p. 61 (1861), from Lake N'gami, may be identical with this species. D. 72; A. 19. Upper surface of head and anal fin blackish.

3. MORMYRUS GUENTHERI, sp. n.

Mormyrus hasselquistii (non C. & V.), Günth. Cat. vi. p. 217 (1866).

Depth of body $5\frac{1}{2}$ times in total length, length of head $4\frac{1}{3}$. Head $1\frac{1}{2}$ as long as deep, with curved upper profile; snout $\frac{1}{2}$ as long as postorbital part of head, projecting a little beyond the mouth; width of mouth $\frac{1}{2}$ length of snout; teeth small, notched, 8 in the upper jaw, 12 in the lower; eye moderate, its diameter $\frac{1}{2}$ length of snout or interorbital width. Dorsal 70, originating in advance of ventral, nearly twice as far from base of caudal as from end of snout, $4\frac{1}{2}$ times as long as anal. Anal 20, originating nearer base of caudal than base of pectoral. Pectoral rounded, a little more than $\frac{1}{2}$ length of head, ventral $\frac{2}{5}$. Caudal with obtusely pointed lobes. Caudal peduncle $1\frac{1}{3}$ as long as deep, $\frac{2}{5}$ length of head. 98 scales in the lateral line, $\frac{17}{20}$ in a transverse series on the

body, 30 in a transverse series between dorsal and anal, 30 round caudal peduncle. Brownish.

Total length 185 millim.

West Africa.

4. MORMYRUS MACROPHthalmus.

Mormyrus macrophthalmus, Günth. Cat. vi. p. 217 (1866).

Depth of body nearly 5 times in total length, length of head 6. Head scarcely longer than deep, with strongly curved upper profile; snout short, $\frac{1}{2}$ as long as postorbital part of head, projecting a little beyond the mouth; teeth very small, feebly notched, 7 in the upper jaw, 8 in the lower; eye large, in the anterior half of the head, nearly as long as the snout, $1\frac{1}{2}$ interorbital width. Dorsal 65, originating slightly in advance of ventral, twice as far from base of caudal as from end of snout, $4\frac{1}{2}$ times as long as anal. Anal 21, originating a little nearer base of caudal than end of snout. Pectoral pointed, as long as the head, ventral $\frac{2}{3}$. Caudal with long pointed lobes, as long as head. Caudal peduncle $2\frac{1}{2}$ as long as head, $\frac{1}{3}$ length of head. 98 scales in the lateral line, $\frac{18}{19}$ in a transverse series on the body, 23 in a transverse series between dorsal and anal, 12 round caudal peduncle.

Total length 290 millim.

West Africa.

5. MORMYRUS OVIS.

Mormyrus ovis, Bouleng. Ann. Mus. Congo, Zool. i. 1898, p. 15, pl. vii. fig. 2.

Depth of body 4 times in total length, length of head $4\frac{3}{4}$. Head $1\frac{1}{4}$ as long as deep, with strongly curved upper profile; snout short, $\frac{2}{3}$ postorbital part of head; teeth very small, notched, 5 in the upper jaw, 8 in the lower; eye moderate, $\frac{1}{2}$ length of snout, $\frac{2}{3}$ interorbital width. Dorsal 53, originating above base of ventral, a little longer than its distance from the end of the snout, $2\frac{2}{3}$ as long as anal. Anal 23, originating a little nearer head than base of caudal. Pectoral obtusely pointed, $\frac{3}{4}$ length of head, ventral $\frac{2}{3}$. Caudal with obtusely pointed lobes, as long as head. Caudal peduncle $2\frac{1}{2}$ as long as deep, $\frac{3}{4}$ length of head. 92 scales in the lateral line, $\frac{26}{18}$ in a transverse series on the body, 29 in a transverse series between dorsal and anal, 16 round caudal peduncle. Pale brownish.

Total length 290 millim.

Upper Congo.

6. MORMYRUS CASCHIVE.

Mormyrus caschive, Hasselq. Iter Palæst. p. 398 (1757); Cuv. & Val. xix. p. 227 (1846); Marcusen, Mém. Ac. St. Pétersb. (7) vii. 1864, no. 4, p. 120; Günth. Cat. vi. p. 215 (1866).

Mormyrus longipinnis, Rüpp. Fortsetz. Beschr. n. Fische Nil, p. 7, pl. i. fig. 2 (1832).

Scrophicephalus longipinnis, Swains. Nat. Hist. Fish. i. p. 309 (1838).

Depth of body 4 to $5\frac{1}{2}$ times in total length, length of head 4 to $4\frac{2}{3}$. Upper profile of head descending in a straight line or feeble curve; snout produced, about as long as the postocular part of the head, its length 2 to 4 times its least depth; mouth very small, with thick lips; teeth small, notched, 5 or 7 in the upper jaw, 8 or 10 in the lower; eye moderate, its diameter about twice in interorbital width. Dorsal 80-87, originating in advance of base of ventral, $5\frac{1}{2}$ to $6\frac{1}{4}$ times as long as anal, $1\frac{1}{3}$ to $1\frac{2}{3}$ as long as its distance from the end of the snout. Anal 18-20, originating at equal distance from the base of the pectoral and that of the caudal. Pectoral obtusely pointed, $\frac{2}{3}$ length of head, ventral $\frac{1}{2}$. Caudal with pointed lobes, densely scaled. Caudal peduncle $1\frac{2}{3}$ to twice as long as deep, $\frac{1}{2}$ length of head. 100-130 scales in the lateral line, $\frac{27-30}{28-35}$ in a transverse line on the body, 38-45 in a transverse line between dorsal and anal, 26 to 30 round caudal peduncle. Olive above, whitish below.

Total length 520 millim.

Nile, Gaboon, Congo.

Mormyrus nacra, Cuv. & Val. xix. p. 257, is founded on a coloured sketch of a fish apparently closely related to *M. caschive*.

7. MORMYRUS NILOTICUS.

Centriscus niloticus, Bloch, Schneid. Syst. p. 113, pl. xxx. fig. 1 (1801).

Mormyrus geoffroyi, Cuv. & Val. xix. p. 240 (1846).

Mormyrus niloticus, Bouleng. Ann. Mus. Congo, Zool. i. 1898, p. 15.

Depth of body less than length of head, $4\frac{1}{2}$ times in total length. Snout long, straight, prolonged in the axis of the body, with slightly concave upper profile; lower jaw slightly projecting. Dorsal 84. Anal 17. Otherwise similar to *M. caschive*, but scales a little smaller.

Total length 300 millim.

Nile.—Known to me only from Valenciennes's description, and Schneider's very imperfect figure.

8. MORMYRUS JUBELINI.

Mormyrus jubelini, Cuv. & Val. xix. p. 252 (1846).

General shape and proportions as in *M. caschive*, but caudal peduncle more slender, and fewer scales round the latter. D. 85; A. 19.

Senegal.—Imperfectly known from Valenciennes's description.

9. MORMYRUS RUME.

Mormyrus rume, Cuv. & Val. xix. p. 248, pl. cccclxix. (1846).

Depth of body $3\frac{1}{2}$ times in total length, length of head 4. Upper profile of head descending in a straight line; snout pro-

duced, about as long as the postocular part of the head, its length $2\frac{1}{2}$ times its least depth; mouth very small, lower jaw slightly projecting; eye small. Dorsal 83, originating in advance of base of ventral, 6 times as long as anal, $1\frac{1}{2}$ as long as its distance from end of snout. Anal 18, originating at equal distance from the base of the pectoral and that of the caudal. Pectoral rounded, $\frac{1}{2}$ length of head. Caudal with obtusely pointed lobes. Caudal peduncle twice as long as deep, $\frac{1}{2}$ length of head. About 100 scales in the lateral line, about 20 round caudal peduncle. Greyish olive.

Senegal.—Paris Museum.

10. MORMYRUS LONGIROSTRIS.

Mormyrus longirostris, Peters, Mon. Berl. Ac. 1852, p. 275; Günth. Cat. vi. p. 216 (1866); Peters, Reise n. Mossamb. iv. p. 83, pl. xvi. fig. 2 (1868).

Mormyrus mucupe, Peters, ll. cc. pp. 275, 87, pl. xvi. fig. 1; Günth. l. c. p. 215.

Mormyrus geoffroyi, Günth. l. c. p. 216.

Mormyrus oxyrhynchus (non Geoffr.), Schilth. Tijdschr. Nederl. Dierk. Ver. (2) iii. 1891, p. 84.

Depth of body $3\frac{2}{3}$ to 5 times in total length, length of head 4 to $4\frac{1}{2}$. Head $1\frac{1}{3}$ to $1\frac{2}{3}$ as long as deep, with curved or nearly straight descending upper profile; snout produced, as long as or a little shorter than the postocular part of the head, its length 2 to $3\frac{1}{2}$ times its least depth; mouth very small, lower jaw slightly projecting; teeth small, notched, 5 or 7 in the upper jaw, 8 or 10 in the lower; eye moderate, its diameter about twice in interorbital width. Dorsal 71–78, originating in advance of ventral, 5 to $5\frac{1}{2}$ times as long as anal, $1\frac{1}{8}$ to $1\frac{1}{4}$ as long as its distance from the end of the snout. Anal 18–20, originating at nearly equal distance from the base of the pectoral and that of the caudal. Pectoral pointed, $\frac{2}{3}$ to $\frac{2}{3}$ length of head, ventral $\frac{2}{3}$ to $\frac{1}{2}$. Caudal with pointed lobes, densely scaled. Caudal peduncle twice as long as deep, about $\frac{1}{2}$ length of head. 95–103 scales in the lateral line, $\frac{30}{38}$ in a transverse series on the body, 40–50 in a transverse series between dorsal and anal, 20–26 round caudal peduncle. Olive above, whitish below.

Total length 190 millim.

Nile, Zambesi, Congo.

11. MORMYRUS KANNUME.

Mormyrus kannume, Forsk. Descr. Anim. p. 74 (1775); Marcusen, Mém. Ac. St. Pétersb. (7) vii. 1864, no. 4, p. 114.

Mormyrus oxyrhynchus, Geoffr. Descr. Égypte, Poiss. i. p. 270, pl. vi. fig. 1 (1829); Joannis, Mag. Zool. 1835, iii. pl. xiii.; Cuv. & Val. xix. p. 242 (1846); Günth. Cat. vi. p. 216 (1866); Hilgend. Sitzb. Ges. nat. Fr. Berl. 1888, p. 78.

Mormyrus bachiqua, Cuv. & Val. l. c. p. 248.

Scrophicephalus kanume, Rüpp. Verz. Mus. Senckenb. iv. p. 27 (1852).

? *Mormyrus hildebrandti*, Peters, Sitzb. Ges. naturf. Fr. Berl. 1882, p. 73.

Depth of body $3\frac{2}{3}$ to $4\frac{2}{3}$ times in total length, length of head 4 to $4\frac{1}{2}$. Upper profile of head descending in a strong curve; snout much produced, about as long as the postocular part of the head, its length $2\frac{1}{2}$ to 3 times its least depth; mouth very small, with thick lips; teeth small, notched, 5 or 7 in the upper jaw, 8 or 10 in the lower; eye small, its diameter 2 or 3 times in interorbital width. Dorsal 58–66, originating above or slightly in advance of base of ventral, $4-4\frac{1}{2}$ times as long as anal, as long as or a little longer than its distance from the end of the snout. Anal 18–21, originating at equal distance from the base of the pectoral and that of the caudal. Pectoral pointed, $\frac{2}{3}$ to $\frac{3}{4}$ length of head, ventral $\frac{1}{2}$. Caudal with obtusely pointed lobes. Caudal peduncle $1\frac{3}{4}$ to 2 as long as deep, nearly $\frac{1}{2}$ length of head. 80–95 scales in the lateral line, $\frac{23-27}{28-33}$ in a transverse series on the body, 35–42 in a transverse series between dorsal and anal, 26 or 28 round caudal peduncle. Brownish or olive above, white beneath.

Total length 480 millim.

Nile; Victoria-Nyanza.—The type of *M. hildebrandti* is from the Adi R., Ukamba, E. Africa.

12. MORMYRUS CABALLUS.

Mormyrus caballus, Bouleng. Ann. Mus. Congo, Zool. i. 1898, p. 16, pl. viii. fig. 1.

Depth of body equal to length of head, $3\frac{2}{5}$ times in total length. Upper profile of head descending in a curve; snout produced, as long as the postocular part of the head, its length about twice its least depth; mouth very small, with thick lips; teeth small, notched, 7 in the upper jaw, 10 in the lower; eye moderate, its diameter 4 times in length of snout and $1\frac{1}{2}$ in interorbital width. Dorsal 62, originating above base of ventral, 3 times as long as anal, as long as its distance from the end of the snout. Anal 23, originating at equal distance from the head and the base of the caudal. Pectoral rounded, hardly $\frac{1}{2}$ length of head, ventral $\frac{2}{5}$. Caudal densely scaled, with obtusely pointed lobes. Caudal peduncle $2\frac{1}{2}$ as long as deep, $\frac{1}{2}$ length of head. 85 scales in the lateral line, $\frac{30}{28}$ in a transverse series on the body, 32 in a transverse series between dorsal and anal, 12 round caudal peduncle. Bluish grey above, vinaceous pink below; fins pink.

Total length 500 millim.

Upper Congo.

13. MORMYRUS PROBOSCIROSTRIS.

Mormyrus proboscirostris, Bouleng. Ann. Mus. Congo, Zool. i. 1898, p. 16, pl. viii. fig. 2.

Depth of body $4\frac{1}{4}$ times in total length, length of head $3\frac{3}{4}$.

Upper profile of head descending in a curve; snout much produced, trunk-like, a little longer than the postocular part of the head, its head $4\frac{1}{2}$ times its least depth; mouth very small, lower jaw slightly projecting, with thick lips; teeth very small, notched, 5 in the upper jaw, 12 in the lower; eye small, its diameter $7\frac{1}{2}$ times in length of snout, 2 in interorbital width. Dorsal 75, originating in advance of base of ventral, nearly 5 times as long as anal, $1\frac{1}{3}$ as long as its distance from the end of the snout. Anal 19, originating at equal distance from the base of the pectoral and that of the caudal. Pectoral obtusely pointed, nearly $\frac{1}{2}$ length of head, ventral $\frac{1}{3}$. Caudal densely scaled, with rounded lobes. Caudal peduncle $1\frac{1}{2}$ as long as deep, less than $\frac{1}{3}$ length of head. 95 scales in the lateral line, $\frac{21}{28}$ in a transverse series on the body, 32 in a transverse series between dorsal and anal, 18 round caudal peduncle. Pink, with a broad bluish-grey stripe extending along each side of the body and tail.

Total length 570 millim.

Upper Congo.

14. MORMYRUS TENUIROSTRIS.

Mormyrus tenuirostris, Peters, Sitzb. Ges. naturf. Fr. Berl. 1882, p. 73.

Depth of body 5 times in total length, length of head $3\frac{1}{3}$. Snout thin, produced, curved downwards; eye in the middle of the head; teeth bicuspid. Dorsal 60, originating further back than base of ventrals, not longer than its distance from the middle of the snout. Anal 20.

Total length 125 millim.

Adi River, Ukamba, East Africa.—Type in Berlin Museum.

9. HYPEROPISUS.

Hyperopisus, Gill, Proc. Ac. Philad. 1862, p. 443; Günth. Cat. vi. p. 222 (1866); Bouleng. Ann. Mus. Congo, Zool. i. 1898, p. 2.

Phagrus, Marcusen, Mém. Ac. St. Pétersb. (7) vii. 1864, no. 4, p. 111.

Teeth in jaws small, notched, few (3–5 in the upper jaw, 5–6 in the lower); parasphenoid and tongue with a pavement of large spheroid teeth; mouth terminal, below the level of the eyes. Nostrils moderately far apart, remote from the eye. Body elongate; ventrals much nearer pectorals than anal. Dorsal very short (12–15 rays); anal very long. Vertebræ 55–59 (15–16 + 4–6 + 35–38).

1. HYPEROPISUS BEBE.

Sonnini, Voy. Égypte, pl. xxi. fig. 3 (1799).

Mormyrus bebe, Lacép. Hist. Poiss. v. p. 619 (1803).

Mormyrus dorsalis, Geoffr. Descr. Égypte, Poiss. p. 276, pl. viii. figs. 1 & 2 (1829); Cuv. & Val. xix. p. 271 (1846).

Phagrus dorsalis, Marcus. l. c. p. 142.

Hyperopisus dorsalis, Günth. Cat. vi. p. 222 (1866); Steind. Sitzb. Ak. Wien, lxi. i. 1870, p. 554, pl. iv. fig. 2.

Hyperopisus occidentalis, Günth. t. c. p. 223.

Depth of body $3\frac{1}{3}$ to 5 times in total length, length of head $5\frac{1}{3}$ to $5\frac{2}{3}$. Head a little longer than deep, with strongly curved upper profile; snout $\frac{2}{5}$ to $\frac{1}{2}$ as long as postorbital part of head; eye moderate, its diameter about $\frac{1}{2}$ length of snout; width of mouth $\frac{1}{5}$ or $\frac{1}{6}$ length of head. Dorsal 12-15, about 3 times as far from the head as from the caudal. Anal 58-65, originating at equal distance from the end of the snout and the root of the caudal, or a little nearer the latter. Pectoral obtusely pointed, $\frac{2}{3}$ to $\frac{3}{4}$ length of head, ventral $\frac{1}{3}$ to $\frac{2}{5}$. Caudal scaly, with obtusely pointed lobes. Caudal peduncle twice as long as deep, nearly $\frac{1}{2}$ length of head. 105-120 scales in the lateral line, $\frac{18-20}{24-28}$ in a transverse series on the body, $\frac{18-20}{20-22}$ in a transverse series between dorsal and anal, 20-22 round caudal peduncle. Plumbeous above, silvery beneath.

Total length 460 millim.

Nile and Senegal.

10. GENYOMYRUS.

Genyomyrus, Bouleng. Ann. Mus. Congo, Zool. i. 1898, p. 17.

Teeth very small, slender, conical, disposed irregularly in several rows in each jaw, forming a villiform band; conical teeth on the parasphenoid and on the tongue; mouth terminal. Body short; ventrals nearer pectorals than anal. Dorsal and anal nearly equally developed. Vertebræ 49 (13 + 7 + 29).

1. GENYOMYRUS DONNYI.

Genyomyrus donnyi, Boulenger, l. c. pl. ix.

Depth of body $3\frac{1}{3}$ to 4 times in total length, length of head 4 to $4\frac{1}{3}$. Head $1\frac{1}{2}$ as long as deep, upper profile straight or slightly concave; snout narrowed, produced, its length $2\frac{1}{2}$ to 3 times its least depth; mouth terminal; chin with a tapering dermal appendage or barbel, nearly as long as the snout, and pointing forwards; eye moderate, in the middle of the head, $3\frac{1}{2}$ times in length of snout, 2 in interorbital width. Dorsal 31-34, originating slightly behind origin of anal (over 2nd or 4th ray), its length $1\frac{1}{2}$ to $1\frac{2}{3}$ in its distance from head. Anal 36-38, equally distant from extremity of ventral and base of caudal. Pectoral obtusely pointed, $\frac{2}{3}$ length of head, a little over twice length of ventral, and extending beyond base of latter. Caudal scaled, with rounded lobes. Caudal peduncle 3 times as long as deep, $\frac{1}{2}$ to $\frac{3}{5}$ length of head. 79-82 scales in the lateral line, $\frac{17-18}{20-26}$ in a transverse series on the body, $\frac{14-15}{13-14}$ in a transverse series between dorsal and anal, 12 round caudal peduncle. Pale brownish above.

Total length 450 millim.

Upper Congo.

11. GYMNARCHUS.

Gymnarchus, Cuv. R. An. 2nd ed. ii. p. 357 (1829); Günth. Cat. vi. p. 225 (1866); Bouleng. Ann. Mus. Congo, Zool. i. 1898, p. 2.

Teeth forming a single complete series on the entire edge of both jaws (14 in the upper, 25-28 in the lower), with compressed, pointed or truncated crowns finely serrated on the sides; palate and tongue toothless; mouth wide, terminal. Nostrils far apart, remote from the eye. Body much elongate, the tail gradually attenuated into a filament. Dorsal occupying the whole length of the body; anal, ventral, and caudal fins absent. Vertebrae 114-120 (45-47 + 67-75). Air-bladder cellular, lung-like.

1. GYMNARCHUS NILOTICUS.

Rifaud, Voy. Égypte, pl. 138 bis (1830).

Gymnarchus niloticus, Cuv. l. c.; Ertl, Abh. Bayer. Ak. v. 1847, p. 209, pl. v.; Heckel, Denkschr. Ak. Wien, vi. 1854, p. 11, pl. i.; Hyrtl, Denkschr. Ak. Wien, xii. 1856, p. 1, pls. i-iv.; Günth. Cat. vi. p. 225 (1866); Steind. Sitzb. Ak. Wien, lxi. i. 1870, p. 556.

Depth of body 7 to $9\frac{1}{2}$ times in total length, length of head $5\frac{1}{3}$ to 6 times. Head 2 to $2\frac{1}{2}$ times as long as deep; snout rounded, scarcely projecting beyond the lower jaw; eye very small; a strong fold of the skin connects the opercles across the isthmus. Dorsal 183-210. Pectoral rounded, $\frac{1}{4}$ to $\frac{2}{7}$ length of head. Scales very small, largest along the middle of the side. Olive or brown above, whitish beneath.

Total length 800 millim.

Upper Nile, Senegal, Niger.

EXPLANATION OF PLATE LI.

Sciagraph of *Gnathonemus rhynchophorus*, p. 810.

5. A List of Butterflies obtained in the Harar Highlands by
Capt. H. G. C. Swayne, R.E. By ARTHUR G. BUTLER,
Ph.D., F.L.S., F.Z.S., &c.

[Received August 20, 1898.]

The small collection of which the following is an account was somewhat hurriedly made, all the specimens having been secured¹ in about three days, at an elevation of from 4000 to 8000 feet on the Harar Highlands. It is therefore not surprising that most of them are a good deal shattered; some of them are nevertheless very acceptable additions to the Museum collection: one species is new.

So little is known even now of the Lepidopterous fauna of this part of Africa that every consignment received thence is of importance and is worthy of careful record, even though many of the examples may have no further value when that record has been published.

¹ They do not appear to have been netted, but rather knocked down and captured by hand.

The following is a list of the species :—

- | | |
|---|--|
| 1. <i>Limnas klugi</i> <i>Butl.</i> | 15. <i>Acræa antinorii</i> <i>Oberth.</i> |
| 2. <i>Byblia ilithyia</i> <i>Drury.</i> | 16. <i>Mylothris agathina</i> <i>Cram.</i> |
| 3. <i>Charaxes brutus</i> <i>Cram.</i> | 17. " <i>yulei</i> ♂ var. ? <i>Butl.</i> |
| 4. <i>Junonia actia</i> <i>Dist.</i> | 18. " <i>swaynei</i> , sp. nov. |
| 5. " <i>octavia</i> <i>Cram.</i> | 19. <i>Colias electra</i> <i>Linn.</i> |
| 6. " <i>pyriformis</i> <i>Butl.</i> | 20. " <i>marnoana</i> <i>Rogenh.</i> |
| 7. " <i>cebrene</i> <i>Trim.</i> | 21. <i>Teracolus phillipsi</i> <i>Butl.</i> |
| 8. " <i>clelia</i> <i>Cram.</i> | 22. " <i>protomeia</i> <i>Klug.</i> |
| 9. " <i>here</i> <i>Lang.</i> | 23. <i>Belenois mesentina</i> <i>Cram.</i> |
| 10. " <i>orthosia</i> <i>Godt.</i> | 24. <i>Leuceronia thalassina</i> <i>Boisd.</i> |
| 11. <i>Pyrameis abyssinica</i> <i>Feld.</i> | 25. <i>Papilio demoleus</i> <i>Linn.</i> |
| 12. <i>Atella columbina</i> <i>Cram.</i> | 26. " <i>erinus</i> , var. <i>Gray.</i> |
| 13. <i>Neptis agatha</i> <i>Cram.</i> | 27. " <i>antinorii</i> <i>Oberth.</i> |
| 14. <i>Acræa serena</i> , var. <i>perrupta</i> <i>Butl.</i> | |

MYLOTHRIS SWAYNEI, sp. n.

♂. Intermediate in character between *M. trimenia* and *M. narcissus*: primaries above milk-white; the costal border blackish, widening gradually into an apical patch which curves round to join the first of three trigonal marginal spots between veins 4 and 5; internal border also blackish to external angle: secondaries bright lemon-yellow; seven small marginal black spots, the first of which (at end of costal vein) is the largest and elongated: body normal. Primaries below white, costal border sprinkled with grey scales; base of cell slightly washed with lemon-yellow; apical border lemon-yellow; a marginal series of seven black dots: secondaries as above: body normal, the pectus clothed with greenish-white hair, becoming somewhat fulvous at the side of the eyes. Expanse of wings 55 millim.

Hab. Harar Highlands.

The following specimens in the collection are worthy of mention :—

The example of *Charaxes brutus* is not only interesting on account of the narrowness of the white band across the primaries, but also because of the prominence of the grey lunulated sub-marginal line of the secondaries.

Acræa antinorii, of which two rather damaged specimens were obtained, was previously known to me only by the illustration (*Annali del Museo Civico di Genova*, xv. tav. i. fig. 3).

The male of *Mylothris yulei* more nearly approaches the typical female than the male which I described; but there is not sufficient evidence to warrant their separation at present.

The example of *Colias marnoana* is larger than those which we previously possessed and tends to link it to *C. sareptensis*.

The two males of *Papilio erinus* are actually more or less intermediate between the var. *pseudonireus* and *Papilio bromius*; it therefore seems probable that *P. erinus* and *P. bromius* will eventually have to be united, in spite of the considerable differences which exist on both surfaces between the extreme forms.

A pair, unfortunately much shattered, of *P. antinorii* was obtained.

6. On a small Collection of Butterflies made in the Chikala District, British Central Africa, by Mr. George Hoare¹.
By ARTHUR G. BUTLER, Ph.D., F.L.S., F.Z.S., &c.

[Received August 23, 1898.]

The present series was forwarded to our Secretary for me by Mr. J. F. Cunningham, Secretary to the Administration, in the hope that they might be useful for the Museum collection, to which I may at once say that it forms a most welcome addition.

Chikala, north end of Lake Shirwa, being new collecting-ground, might be expected to yield new species to the explorer; but the present consignment (which comprises examples of only twenty-one species) contains nothing hitherto unnamed, although one of the ten forms of *Charaxes* in the collection is of considerable interest to me, not only as being the first female specimen which we have acquired, but as proving that I was correct in placing *C. lactetinctus* next after *C. azota* in my arrangement of the genus.

Considering that most of the specimens in this collection belong to the muscular-winged genus *Charaxes*, we may congratulate Mr. Hoare that so many of them are in good condition. The following is a list of the species:—

1. *AMARIS WHYTEI* Butl.

A single perfect male example.

2. *MELANITIS SOLANDRA* Fabr.

One female.

3. *EURYTELA HYARBA*, var. *ANGUSTATA* Auriv.

A perfect male, with the band on the secondaries nearly as wide and the markings below as distinct as in the typical Western form.

4. *CHARAXES BRUTUS* Fabr.

Two perfect male specimens.

5. *CHARAXES POLLUX* Cram.

A pair. The female of this species is rather rare.

6. *CHARAXES CASTOR*, var. *FLAVIFASCIATUS* Butl.

A nearly perfect male.

7. *CHARAXES GUDERIANA* Dewitz.

A perfect male.

8. *CHARAXES AZOTA*, var. *NYASANA* Butl.

A nearly perfect female. Quite new to the Museum collection.

¹ Assistant Collector of Revenues for the Chikala District.

The female of the Delagoa Bay form (the typical *C. azota* of Hewitson) has been figured by Mrs. Monteiro in her 'Delagoa Bay, its Natives and Natural History,' frontispiece, fig. 1.

9. *CHARAXES MACCLOUNII* Butl.

Four females, three of them a little worn, but not much broken.

10. *CHARAXES CANDIOPE* Godt.

A male almost perfect.

11. *CHARAXES CITHÆRON* Feld.

Two perfect males.

12. *CHARAXES BOHEMANI* Feld.

Three females, a little worn.

13. *CHARAXES VARANES* Cramer.

Five examples, two being almost perfect. This species usually comes to hand in very poor condition.

14. *JUNONIA SESAMUS* Trimen.

Two fine specimens.

15. *PYRAMEIS CARDUI* Linn.

A slightly worn male.

16. *HYPANARTIA SCHÆNEIA* Trimen.

A rather rubbed male.

17. *EURALIA WAHLBERGI* Wallgr.

A perfect male.

18. *CATOPSILIA FLORELLA* Fabr.

Two much-worn females.

19. *PAPILIO SIMILIS* Cram.

A slightly damaged male.

20. *PAPILIO DEMOLEUS* Linn.

Two good males.

21. *PAPILIO MEROPE*, var. *DARDANUS* Brown.

Four males and one female in good condition.

7. On a small Collection of Butterflies from British East Africa, obtained at the end of 1897 and beginning of 1898 by Mr. R. Crawshay. By ARTHUR G. BUTLER, Ph.D., F.L.S., F.Z.S., &c.

[Received August 26, 1898.]

In a letter addressed to me from Kibwezi, Ukamba, and dated March 5th, 1898, Mr. Crawshay writes:—

“A line in pencil to let you know my movements, and that I am on my way to the promised land—of this Protectorate at least.

“I hope you have received the few, *very few*, insects I sent you by Wilson, of the National Bank of India in Mombasa, who was kind enough to take charge of them. They are so few that I was almost ashamed to send them; but, having promised, I did so in the hope that perhaps the Skippers, or at any rate one of them, would prove of interest.

“I am now on my way to Machako's, and am camping here for one day to ration my porters, rest them, rest myself, and rearrange my loads—a never-ending task! African travel on foot is slow and very irksome and at times positively exasperating, I can assure you: one has so many difficulties to contend with, the chief perhaps being the waywardness of one's porters, and indeed of almost all one's dusky followers, to say nothing of discomforts innumerable. But it is intensely fascinating for all that, and I can't tell you how glad I am to get back to the old life I love so well.

“Certainly British East Africa, and especially the Ukamba Province, is more healthy than British Central Africa: one feels that at every breath.

“It is hot, very hot, but also very dry; and so one does not feel the temperature nearly so much as one would do otherwise.

“I took a magnificent pair of Spiders—huge they are even for Africa—on the dry plains S.E. of this, three days ago.

“Hitherto I have seen no four-footed game, but there is plenty ahead.”

The collection was handed over to me by Mr. Wilson, and I found it to consist of examples of 21 species—most of them collected at Takaungu, north of Mombasa, between the 19th of November and 6th of December, 1897; the remainder having been obtained at Mombasa on the 23rd January, 1898.

As usual with Mr. Crawshay's collections, the specimens are in good condition, and although none of them are new to science, several are of interest; as, for instance, a dry-season female of *Ypthima pupillaris*, two highly coloured males of *Lachnocnematibulus*, differing greatly in size, the somewhat rare white form of the female of *Teracolus imperator*, a dry-season female of *T. dissociatus*, a very tiny and somewhat aberrant male of *T. omphale*, the intermediate phase of the red-tipped variation of *T. callidia*, and two fine males

of *Eronia dilatata*. The *Hesperidæ*, though not new, were welcome additions to our series of two rather handsome species.

The following is a list of the species, with a few notes by the collector :—

NYMPHALIDÆ.

1. LIMNAS CHRYSIPPUS var. KLUGII Butl.

Two females, Mombasa, 23rd January, 1898.

2. YPTHEMA PUPILLARIS Butl.

A dry-season female, Mombasa, 23rd January, 1898.

3. JUNONIA CLELIA Cramer.

♀, Takaungu, 3rd December, 1897.

LYCENIDÆ.

4. CATOCHRYSOPS OSIRIS Hopff.

Two males differing greatly in size, Mombasa, 23rd January, 1898.

“Plentiful, but difficult to see” (*R. C.*).

5. AZANUS JESOUS Guér.

♀, Takaungu, 6th December, 1897.

6. TARUCUS PLINIUS Fabr.

A tiny female, Takaungu, 6th December, 1897.

7. LACHNOCNEMA BIBULUS Fabr.

Two males, Takaungu, 3rd December, 1897.

“Taken playing together and disputing for the same perch on a rose-bush” (*R. C.*).

8. VIRACHOLA ANTALUS Hopff.

♂, Mombasa, 23rd January, 1898.

“Plentiful, but difficult to see” (*R. C.*).

9. IOLAUS PHILIPPUS Fabr.

♂, Takaungu, 6th December, 1897.

PAPILIONIDÆ.

10. TERACOLUS IMPERATOR Butl.

♂ ♀, Takaungu, 3rd and 5th December, 1897; ♂, Mombasa, 23rd January, 1898.

11. TERACOLUS DISSOCIATUS Butl.

♀ *dry form*, Takaungu, 5th December, 1897.

“A frequenter of dense scrubby bush” (*R. C.*).

12. *TERACOLUS EVARNE* Klug(?).

♂ *dry form*, Takaungu, 3rd December, 1897.

This example has the pattern of the variety to which I gave the name of *T. syrtinus*, but the upper surface is almost pure white; it may possibly be a dry-season male of the preceding species from which the usual rosy coloration of the under surface is wanting. The dry phases of several of the species of this genus are much more similar than the wet phases, and single examples which differ from the typical variation are consequently sometimes not to be identified with certainty, but have to await further evidence.

13. *TERACOLUS XANTHUS* Swinh.

♀, Takaungu, 5th December, 1897.

14. *TERACOLUS OMPHALE* Godt.

♂, Takaungu, 5th December, 1897.

The smallest male I have seen and somewhat aberrant in the pattern of the primaries, the black border not reaching the external angle, and the subapical orange patch narrow, not angulated internally, and wanting its last or lowest section.

15. *TERACOLUS CALLIDIA* Grose-Smith.

♀, Takaungu, 5th December, 1897.

The intermediate phase of the red-tipped variety.

16. *TERACOLUS CATACHRYSOPS* Butl.

♂, Takaungu, 6th December, 1897.

A dry-season example having the spots across the secondaries larger than usual. As in *T. protomedia* the wet and dry phases of this species are indicated by the brown or crimson bands across the under surface of the secondaries.

17. *LEUCERONIA BUQUETII* Boisd.

♂, Takaungu, 3rd December, 1897.

18. *ERONIA DILATATA* Butl.

Two males, Takaungu, 6th December, 1897.

19. *PAPILIO DEMOLEUS* Linn.

Two males, Mombasa, 23rd January, 1898.

HESPERIIDÆ.

20. *PLETSIA CERYMICA* Hewits.

♀, Takaungu, 19th November, 1897.

"Full of large brown ova" (*R. C.*).

21. *RHOPALOCAMPTA KEITHLOA* Wallgr.

Four specimens, Takaungu, 3rd and 5th December, 1897.

"Fond of perching on outstanding branches of mangrove trees" (*R. C.*).

8. Notes on the Collection of Specimens of the Genus *Millepora* obtained by Mr. Stanley Gardiner at Funafuti and Rotuma. By Professor SYDNEY J. HICKSON, M.A., F.R.S., F.Z.S.

[Received October 4, 1898.]

This collection consists of a dozen large dried coralla and several smaller pieces and fragments, together with nearly three dozen pieces of different forms of growth preserved in spirit.

As I have already pointed out in a communication to this Society, there is no reason to suppose that there is more than one species of this genus, but there are nevertheless several characters of interest presented by specimens from different coral-reefs which are deserving of record. I propose to use the term "Facies" for the general form of growth of the specimens described, and to retain as far as possible under this term the names previously used for species.

I. *The dried Coralla.*

MILLEPORA ALICORNIS L.

Facies "*ramosa.*"

There are several specimens in the collection which under the old system would have been placed in the species *Millepora ramosa* Pall.

The principal features of this facies are that the branches are thick and usually cylindrical, anastomosing freely below, but having at the extremities a number of free obtusely pointed branches.

One of the most interesting specimens of this facies was obtained at the S. entrance in Funafuti, at a depth of 7 fathoms. The stem divides into branches in a vertical plane, which freely anastomose, forming a wide-meshed network 10 inches in height. The main stem is nearly an inch in diameter and the principal branches of it are on an average $\frac{1}{2}$ an inch in diameter.

The colour of the corallum is pale yellow. There are no parasitic barnacles on any of the branches of this specimen, but the Gastropod, *Calliostoma similaris* (Reeve), and the Pelecypod, *Avicula formosa* (Reeve), were found adhering to the specimen.

The genus *Millepora* being regarded as an essentially shallow-water form, collectors rarely give the depth at which their specimens were obtained, and we have in consequence very little information concerning its bathymetrical range.

Tenison-Woods says that *Millepora undulosa* occurs in 20 fathoms in Foveaux Straits, Moore and Smith found living *M. ramosa* in 15 fathoms, and Gardiner obtained the specimens here recorded in 7 fathoms¹. These are the only statements I can find giving a definite range beyond low-tide mark.

¹ Mr. Gardiner's notes on the localities of the facies "*ramosa*" are as follows:—"It grows very abundantly immediately outside the deep channels to the S.E. and N.W. of the Atoll Funafuti. I also obtained it off Pava. In the

Some doubt may be felt as to whether the coral collected by Tenison-Woods was really a *Millepora*. The description given of it is not sufficiently detailed to give great confidence in the belief that a Millepore exists in deep water so far south as the Foveaux Straits; but there can be no doubt whatever about the other two statements; and it is interesting to note that in both cases in which Millepores have been dredged at a depth well below low-water mark, *i. e.* in places where the growth in height cannot be limited by exposure to the air, the facies is "*ramosa*." Moseley says that *M. ramosa* "appears to thrive best in the shade"¹.

The yellow colour of the corallum of the Funafuti specimens from 7 fathoms is in accordance with the statement made by Forskål that the species *M. dichotoma* "*inhabitat profundum*," and is of a "*color flavicans*," *M. dichotoma* being regarded as a synonym of *M. ramosa* by some authors. But the yellow colour is not confined to deep-water forms, nor to forms of this facies, for Moseley says that the *Millepora nodosa* from Tahiti, found in one or two feet of water, is of a bright yellow colour, and Mr. Gardiner tells me that a species coloured orange-brown was fairly common on one shoal to the windward side of the lagoon at Funafuti. It is possible, however, that the white bleached coralla occurring on many reefs are confined to the shallow water and that in a few fathoms of depth all the Millepores are naturally yellow.

There is another piece of corallum in Mr. Gardiner's collection which must be included in this facies, which is of interest as being found in shallow water and showing a flattening and expansion of the branches, which if it were carried a little further would lead to the formation of plates. Millepores living in very shallow water cannot grow to more than a certain height, and their growth upwards is checked and stopped by the low tides. It is probable that a lateral expansion of the branches follows any check to the growth given to the distal extremities, and that ultimately the broadened branches fuse together to form lamellæ or plates.

The diameter of the mouth of the gastropores on a medium-sized branch of this form is, on taking an average of 12, found to be 0.276 mm.

Facies "*esperi*."

A specimen in the collection 6½ inches in height, springing from a basis 2¾ inches × 7 inches, from shallow water, S. passage, Main Island, Funafuti, agrees most closely with the description given of *Millepora esperi* by Duchassaing and Michelotti. The form of the corallum is not unlike that assumed by large specimens of

lagoon it occurs only near the deep channels. It occurred in 7 fathoms of water off the entrance between Falefatu and Mateika." Mr. Gardiner also believes that he obtained small pieces of *Millepora* in 20 fathoms off the N. entrance near Pava, and in 30 fathoms off Falefatu; but as there is just a possibility that the pieces observed may have remained sticking to the swab from a previous dredging, he does not wish me to consider the evidence to be conclusive.

¹ H. N. Moseley, "Notes of a Naturalist on the 'Challenger,'" p. 27.

Alcyonium digitatum, being thickly palmate with short obtuse and warty branches.

The most striking feature about this Millepore, and fragments of others which I judge must have had a similar form, is the great thickness of the "live" corallum. The apparent thickness of Millepore branches is often very misleading, for it may be observed that in many specimens the apparent thickness is due to the Millepore having grown over a dead coral and completely encrusted it.

Some of the branches of this coral are actually more than 22 mm. in diameter. They are the thickest branches of live Millepore corallum I have had the opportunity of examining.

I have satisfied myself that in most cases the pores are continuous from the surface to the centre without any break but that of the tabulæ. In some of these pores there must be at least 35 tabulæ, which is more than twice as many as in any other Millepore I have carefully studied.

The texture of the corallum is light and brittle, the colour white, and the surface almost free from barnacles and worm parasites.

All of these features suggest that the conditions under which these specimens lived were particularly favourable, that the growth of the corallum was rapid, and the conditions of its tissues so healthy that it could resist the action of the larvæ of parasites.

Mr. Gardiner tells us that *Millepora* of the facies "*esperi*" occurs most abundantly in the lagoon on each side of the passages to windward, and never where it would be directly exposed to the rush of the tide. In this situation it forms large clumps, commonly as much as 7 or 8 feet in diameter, rising out of 5-10 feet of water to a foot from the surface at ordinary low tide. It also occurs sparingly by the passages to leeward, and on some of the more exposed shoals in the lagoon.

The lightness and brittleness of these specimens form a very striking feature, and it occurred to me that it might be expressed in figures fairly accurately by the specific gravity, which was found to be 2.53. Compared with other Millepores this is decidedly low. The sp. gr. of a fragment of facies "*ramosa*" was 2.9, of a complanate form from Funafuti also 2.9, of a complanate form in the Manchester Museum 3.17.

Facies "*complanata*."

There is one large specimen, 20 cm. in height, which resembles the form of growth of *M. complanata*, and there are several fragments similar to it in the collection. Mr. Gardiner says it is not common in the lagoon, being found only on certain shoals close together towards the E. side.

The large specimen consists of five coalescent laminæ, the free edges of which are divided in some places into short, blunt digitations or tubercles. The thickness of the laminæ varies considerably, but the average thickness is about 1 cm. The average number of

tabulæ in each pore is about 17. The specimen appears to have been in a very sickly condition when taken. More than $\frac{2}{3}$ of one face of it is dead coral, and the other face is considerably attacked by Algæ. Nearly the whole of the "live" surface is pitted with *Pyrgoma millepora*. In one place I counted no less than 13 young cirripedes in an area $1 \times 1\frac{1}{2}$ centimetres.

On the surface of a fragment which was probably broken off this specimen there may be seen several ampullæ.

The specimens of *Millepora* collected by Mr. Gardiner in Rotuma are of two kinds. They were found only in the boat-channel, there being none on the reef. One of these consists of coralla of light texture, of branching habit, similar to that usually considered characteristic of *Millepora alvicornis*. The branches are disposed in a single plane and freely anastomose, their average thickness being about 5 mm. They are free from parasitic cirripedes and show on some of the branches numerous ampullæ.

The other kind consists of very hard dense coralla, partly or wholly encrusting dead coral, but as the free edges rise into plates with crested borders they correspond most closely with the species *M. plicata*. Hence they may be considered under the term facies "*plicata*." The thickness of the live corallum is rarely more than 3 mm. from each surface, and its great hardness affects the manner of its fracture in such a remarkable way that great difficulties present themselves when an attempt is made to count the tabulæ in each pore. From the (small) number of pores I have been able to examine, I arrive at the conclusion that there cannot be on an average more than five tabulæ in each.

One of these specimens shows the scars of numerous ampullæ.

The surface of all these forms from Rotuma is remarkably clean and free from parasites of all kinds.

The remarkable hardness of the corallum makes the pores very apparent, and gives them the appearance of being much larger than they really are. On first handling the specimen I thought the pores were the largest I had seen, but on measuring the diameters of 12 gastropores on one face of a specimen I found the average to be only 0.27 mm., and on the opposite face the average of five or six which I measured was less than 0.2 mm. These figures show how deceptive estimates of size may be which are made by unassisted vision. The pores of the facies "*plicata*" from Rotuma are actually smaller than those of the facies "*ramosa*" from Funafuti, and yet they have very decidedly the appearance of being larger.

The remarkable difference in size between the gastropores on one face of the corallum and on the other which is recorded above is by no means exceptional. In nearly every case in which I have compared the average diameter of 12 gastropores from one part of a corallum with an average of 12 on another I have found a certain difference. It is probably to be accounted for by the difference in food-supply, fresh water, or other external conditions

to which the different parts of a colony are exposed in their natural position on the reef.

II. *Spirit-specimens.*

Facies "*ramosa.*"

Mr. Gardiner killed in corrosive sublimate and preserved in spirit some specimens of this facies which he obtained in 7 fathoms of water at Funafuti. It was clearly of importance to see if the soft parts of the deep-water ramose forms differ in any degree from the shallow-water lamellate forms.

I found the material in excellent condition for the investigation, as many of the gastrozooids appeared to be fully expanded, and some of the dactylozooids partially so, and I was able in consequence to see in a particularly favourable manner the small and large nematocysts, the tentacles, and the histology of the polyps.

The nematocysts are, so far as I can judge, exactly the same as in all other Millepores. I have been unable to find any of the large kind exploded in my preparations, and consequently I can say nothing about the character of the thread. The condition of these large nematocysts varies considerably in different specimens of Millepores; sometimes they may be found in all stages of development, but more frequently they are nearly all in one stage. Sometimes nearly all the ripe nematocysts of this kind may be seen with their threads attached to them, sticking into the superficial ectoderm or just below it; in others, again, not a single exploded nematocyst can be found. In the specimens I am now describing the absence of exploded nematocysts may be accounted for by believing that they were washed off in coming up in the dredge, but I am not certain that that explanation is quite satisfactory. The unexploded nematocysts measured $\cdot 02$ mm. \times $\cdot 025$ mm., *i. e.* the exact size of the large nematocysts of other Millepores. The manner in which the thread is coiled up inside the vesicle is also the same as in other Millepores.

The small kind of nematocyst which is found characteristically in the tentacles of gastrozooids, but occurs also more rarely in the cœnenchym, varies in size considerably, but the largest of them are exactly $\frac{2}{3}$ the length of the large kind of nematocyst, and are consequently normal in size. In one instance I have seen the swollen base of the thread armed with three spines, as described and figured by Moseley. There is no reason, therefore, to suppose that the nematocysts of this form differ from those of other Millepores.

As in all other specimens I have examined, the canals contain numerous zooxanthellæ. They are a good deal more crowded than usual in the superficial canals, as might be expected in forms living in deeper and consequently darker water. Each zooxanthella is perfectly spherical in form, being $\cdot 0125$ mm. in diameter. They exhibit no peculiar features.

The gastrozooids and dactylozooids are exactly the same in all essential features as the gastrozooids and dactylozooids of other well-preserved Millepores which I have examined.

Facies "*complanata*."

The spirit-specimens of this facies were collected in shallow water at Funafuti, and are, like the dried specimens, very considerably affected by barnacles and other parasites. Unfortunately the state of preservation was not perfect, and many details of histology could not be made out at all.

The preparations are, however, of very great interest, as showing medusæ bearing spermacytes. Many of the medusæ are quite loose in their ampullæ, and are shaken out of them during decalcification, so that they can be mounted whole. The largest medusæ mounted in this manner were about .57 mm. in diameter; but as it is impossible to prevent them from being slightly compressed as the Canada balsam dries, we may consider that their diameter is only a little over $\frac{1}{2}$ mm. This is almost exactly the same size as the male medusæ in Professor Haddon's collection.

Facies "*plicata*," from Rotuma.

Several specimens of this form were killed in corrosive sublimate, washed with iodine, and preserved in spirit. They are all in an excellent state of preservation.

Many of the specimens show on the surface shallow round depressions about $\frac{1}{2}$ mm. in diameter, which so closely resemble the scars of the ampullæ seen on the dried coralla, that there can be no doubt that they represent the spaces from which the medusæ have escaped. The depression is, however, overgrown by ectoderm and possibly a certain amount of the endoderm's canal-system as well, so that when the specimens are decalcified all trace of these depressions disappear. In studying the ampullæ of dried coralla I was much struck with the fact that they are never found anywhere but in the superficial layer of the corallum, and I was inclined to believe at one time that when the colony of a Millepore had once produced medusæ it died. This view, however, was not confirmed by the examination of Prof. Haddon's material from Torres Straits, in which the medusa-bearing colonies showed every sign of being in a thoroughly healthy and actively feeding condition.

The Millepores from Rotuma confirm the opinion that my former view was wrong, since several of the gastrozooids contain food in the form of minute Crustacea, and the ectoderm and other tissues are all thoroughly sound and healthy. The specimens prove, moreover, that when the outer wall of the ampulla is broken to allow the escape of the medusa, the cœnosarcial tissue covers over the gap, and in time obliterates all signs of it.

It is quite impossible, of course, to form any estimate of the length of time that elapsed from the escape of the medusæ until the specimen was collected, but it is noteworthy that not a single medusa remains. I have decalcified more than three quarters of the material sent to me, and have searched through the whole of the material thus decalcified with a powerful lens, but I can find no trace of a medusa, and in the sections I have cut there are no signs of any sexual organs.

9. Report on the Holothurians collected by Mr. J. Stanley Gardiner at Funafuti and Rotuma. By F. P. BEDFORD, B.A., King's College, Cambridge¹.

[Received October 13, 1898.]

(Plates LII. & LIII.)

My thanks are due to Prof. F. J. Bell and Mr. J. Stanley Gardiner for giving me the opportunity of examining and describing the Holothurians collected by the latter at Rotuma and Funafuti in the S. Pacific. I have freely availed myself of the suggestions of both Prof. Bell and Mr. Gardiner, and am particularly grateful to the former for allowing me the use of a room to work in at the Natural History Museum, South Kensington, where I have been able to compare the specimens with the collection in the Museum, and where in consequence the task of identification has been much simplified. Prof. Bell, too, has kindly gone through the whole paper and corrected the proofs.

Any errors or shortcomings in the present paper I am of course solely responsible for.

The most generally useful books for the determination of *species* I found to be K. Lampert, 'Die Seewalzen,' in Semper's Reisen im Arch. Philipp. Bd. iv. 1885, and H. Théel, 'Challenger' Reports, pt. 39, *Holothurioidæ*, ii. 1885.

The *genera* have undergone considerable revision since 1885, and the best recent diagnosis of the Holothuriidæ is given by Prof. Ludwig in Memoirs of Mus. of Comp. Zool. Harvard College, vol. xvii. no. 3, 1894, p. 37, which may be regarded as a supplement to his account in Bronn's Thier-Reich, Bd. ii. Abt. 3, Bde. i. 1889/92, pp. 327-361².

I have adopted this classification, with the single exception that I have followed Prof. Bell in substituting the name *Actinopyga* for *Mülleria* for the reasons stated by him (Ann. & Mag. Nat. Hist. xix. (1887) p. 392, and xx. p. 148).

The works by Dr. Lampert and Dr. Théel were in nearly all cases used in determining species, and I have therefore thought it unnecessary to repeat the references in each case in the text. I have been unable to obtain Dr. Sluiter's paper in Bijdrag tot de Dierk. Afl. xvii. 1895, entitled "Die Holothurien-Sammlung des Museums zu Amsterdam," and have had to rely on abstracts in Zool. Centralblatt, ii., and 'Zoological Record' for 1895; in all other cases I have had access to the original papers.

I have used the terms "dorsal" and "ventral" in the conventional analogical sense for "bivium" and "trivium" respectively.

¹ Communicated by F. JEFFREY BELL, M.A., F.Z.S.

² Dr. H. Östergren (Öfvers. af Kgl. Vet.-Ak. Förhandlingar, lv. no. 2, 1898, p. 111) and M. Perrier (Comptes Rendus, t. cxxvi. no. 23, 1898, p. 1664) have somewhat amplified Prof. Ludwig's classification of the Synaptidæ and the Synallactinæ respectively.

In noting the horizontal distribution I have employed the terms used by Dr. A. E. Ortmann in his 'Grundzüge der marinen Tiergeographie,' 1896; in giving the size of specimens I have taken greatest length and greatest breadth.

The collection comprises examples of 12 species of *Aspidochirota*, 1 *Dendrochirota*, and 5 species of *Synaptidæ* (one of which is new); the following is a list:—

List of Species.

1. *Actinopyga* [*Mülleria*] *echinites* Jaeger ?, p. 836.
2. — [—] *mauritiana* Quoy & Gaimard, p. 835.
3. — [—] *parvula* Selenka, p. 836.
4. *Holothuria atra* Jaeger, v. *amboinensis* Semper, p. 839.
5. — *difficilis* Semper, p. 838.
6. — *fuscocinerea* Jaeger, var. *pervicax* Selenka, p. 837.
7. — *impatiens* Forskål, p. 840.
8. — *maculata* Brandt, p. 842.
9. — *monacaria* Lesson, p. 841.
10. — *pardalis* Selenka, p. 839.
11. — *rugosa* Ludwig, p. 839.
12. — *vagabunda* Selenka, p. 842.
13. *Pseudocucumis africana* Semper, p. 843.
14. *Synapta godeffroyi* Semper (genus *Euapta* Östergren), p. 847.
15. — *kefersteini* Selenka (genus *Chondrodea* Östergren), p. 847.
16. — *ooplax* v. Marenzeller (genus *Synapta* Östergren), p. 848.
17. *Chiridota intermedia*, sp. nov., p. 846.
18. — *liberata* Sluiter, p. 845.

As will be seen, I propose to combine *Actinopyga parvula* Selenka and *A. flavocastaneu* Théel under the former specific name, and *Holothuria fuscocinerea* Jaeger et Semper with *Holothuria pervicax* Selenka.

Most of the species in the collection are widely distributed tropical forms, but I have thought it worth while to note any discrepancies between the individual specimens and the specific descriptions. The variations in the tentacles of *Pseudocucumis africana* Semper seem to be of interest from several points of view.

From the list of species it will appear that there is one which I believe to have been hitherto undescribed and which I have called *Chiridota intermedia*. As is well known, the species of *Chiridota* are very difficult to diagnose and separate from one another; the attempts that have been made to classify them on the minute structure of their wheels have not met with much success, and until more is known of the changes which take place during the growth of the individual, the specific differences must appear unsatisfactory—at any rate, the present species seems to be at least as definite as most others of the genus.

ASPIDochIROTÆ.

ACTINOPYGA MAURITIANA Quoy & Gaimard.

Holothuria mauritiana Quoy & Gaimard, Voyage de l'Astrolabe, iv. Zooph. 1833, p. 138.

Mülleria varians Selenka; E. Selenka, Z. f. w. Z. xvii. 1867, p. 310, Taf. xvii. figs. 4-9.

Reference. K. Lampert, Zool. Jahrb. Syst. Bd. iv. 1889, p. 813.

Distribution. Distributed over the Indo-Pacific region of the tropical zone from as far W. as Mozambique ('Alert') to as far E. as Society Is.

Two specimens from Rotuma, the largest being 91 mm. \times 30 mm., seem to resemble in every respect the specimens collected by H.M.S. 'Challenger' and described by Théel, p. 201. They differ from the specimen described by Lampert from the Lucepara Is. in the absence of the arrangement of ventral feet in rows, although patches occur on the ventral surface, where the feet are less closely arranged than elsewhere.

ACTINOPYGA ECHINITES Jaeger.

Mülleria echinites Jaeger, De Holothuriis, pp. 17, 18.

Reference. Théel, 'Challenger' Holothurioidea, ii. p. 201.

Distribution. The species has been recorded from Fiji, Great Barrier Reef, Amboina, Thursday Is., Celebes, Sumatra, and Indian Ocean (Seychelles); it is thus fairly widely distributed over the Indo-Pacific region of the circumtropical zone. One specimen from Rotuma, 40 mm. \times 15 mm., appears to belong to this species. It resembles Théel's description of the Fiji specimen in every particular except in colour, which is whitish brown with a few irregular dark patches on the dorsal surface; the ventral surface is lighter than the dorsal, and the tube-feet and papillæ are darker than the ground-colour.

The anal teeth are quite visible to the naked eye, and the deposits are like those described by Théel, except that they appear to have undergone a certain amount of solution and in consequence the identification is not certain.

ACTINOPYGA PARVULA Selenka. (Plate LIII. figs. 1 a-d.)

Mülleria parvula E. Selenka, Z. f. w. Z. xvii. 1867, p. 314, Taf. xvii. figs. 17, 18.

Mülleria flavocastanea Théel; H. Théel, 'Challenger' Hol. ii. 1885, p. 198¹.

Distribution. The species thus constituted is one of the most widely distributed circumtropical forms: it is recorded from the West African region (Madeira), East American region (Florida), and greater part of the Indo-Pacific from Seychelles Is. to Samoa, including the Red Sea.

A large number of specimens from Funafuti lagoon 20 fathoms and from the "mangrove swamp," largest about 25 mm. \times 7 mm. As the specimens combine a number of characters of *A. parvula* and *A. flavocastanea* it seems worth while to describe them somewhat minutely. Théel has himself suggested the possibility that

¹ *Hol. sp. n.,? juv.*, described by Ludwig (Zool. Jahrb. Syst. iii. p. 808, figs. 1-5), seems to be closely allied to this species, although no mention is made of anal teeth and it appears thus to be a true *Holothuria*.

A. parvula is the young of *A. flavocastanea*, and all the evidence seems to favour the identity of the two forms.

Colour uniform brown; number of tentacles 18 in one specimen (not countable in others).

Deposits agree almost exactly with Selenka's description and figures; the tables (Plate LII. fig. 1 *b*) are very crowded, frequently overlapping, and form a layer outside the buttons (fig. 1 *c*), which rarely possess less than 4 pairs of holes. The spiny rods mentioned by Selenka as occurring in the dorsal feet are very scarce (fig. 1 *d*), but sieve-plates (fig. 1 *c*) occur arranged in circles below the end-discs of the ventral and some of the dorsal feet.

The ventral feet are arranged in very distinct rows; dorsal feet much smaller and more papilliform and not arranged in rows; anal teeth five in number, small, and forming more or less irregular oval fenestrated plates, recalling the anchor-plates of some species of *Synapta*.

I could not make certain of the maturity of any of the specimens, but in one of the smallest, the only one of which I cut sections, ova were developed on the dorsal mesentery; the same specimen possessed one stone-canal completely embedded in the mesentery, two Polian vesicles, and tolerably well-developed tentacular ampullæ; Cuvierian organs were very well developed in all the specimens opened.

From the above description it will be obvious that the only points of distinction that can be maintained between *A. parvula* and *A. flavocastanea* are (1) colour and (2) size¹, both of which may be due either 1) to age or (2) to local variation.

HOLOTHURIA FUSCOCINEREA Jaeger, var. PERVICAX Selenka.
(Plate LII. figs. 2 *a*, *b*.)

Holothuria pervicax Selenka; E. Selenka, Z. f. w. Z. xvii. 1867, p. 327, Taf. xviii. fig. 54.

Holothuria depressa Ludwig; H. Ludwig, Arb. a. d. zool.-zoot. Inst. in Würzb. 1875, p. 108, Taf. vii. fig. 44.

Holothuria mammiculata Haacke; Möbius, Meeresfauna d. Ins. Maur. u. d. Seych. 1880, p. 48.

Var. of *H. fuscocinerea* Jaeger et Semper; G. F. Jaeger, De Holothuriis, 1833, p. 22; C. Semper, Reisen im Arch. Phil. Bd. i. *Hol.* 1867, pp. 88, 250, Taf. xxvii. & xxx. fig. 22=*H. curiosa* Ludwig; H. Ludwig, Arb. a. d. zool.-zoot. Inst. in Würzb. 1875, p. 110, Taf. vii. fig. 29.

References. H. Ludwig, Ber. Oberh. Ges. Wien, xx. 1883, p. 173.

H. Théel, 'Challenger' Reports, xxxix. *Hol.* ii. 1885, pp. 220-222.

Distribution. The species is widely distributed over the Indo-Pacific area, extending as far W. as Japan. Four specimens from

¹ From the Zool. Record, 1895, it appears that Sluiter has described a specimen of *A. flavocastanea* 20 cm. long.

Rotuma : (1) 50 mm. \times 20 mm. ; (2) 64 mm. \times 19 mm. ; (3) 45 mm. \times 18 mm. ; (4) 47 mm. \times 23 mm.

Deposits quite agree with Ludwig's later description (1883, *l. c.*) of *H. pervicax* ; the tables have, as a rule, a rudimentary spire and are not frequent ; in a small piece all the different forms of deposits from those typical of *H. pervicax* Selenka to those typical of *H. depressa* Ludwig can easily be found, a few approaching those typical of *H. fuscocinerea* Jaeg. (*v. fig. 2 b*).

This species, like *H. atra* Jaeg., has been repeatedly described under a new name on account of the great amount of variation to which its deposits are subject.

Like *H. atra* it seems to occur in two well-marked forms : var. (1), first described by Semper under the name of *H. fuscocinerea* Jaeg., and later by Ludwig as *H. curiosa*, in which the deposits consist of sparsely distributed tables (some, according to Théel, with more than one transverse beam) and somewhat irregular small buttons, which become more elongated in the ambulacral appendages ; and var. (2), first described by Selenka under the name *H. pervicax* and later by Ludwig as *H. depressa*, which differs in the fact that the buttons are not so completely formed : in arrangement of ambulacral appendages, calcareous ring, and internal anatomy, the two varieties seem to be identical ; in colour they differ slightly¹. I have had an opportunity of examining some of Prof. Semper's original specimens, and those from Samoa which he describes as varieties of *H. fuscocinerea* (Semper, *l. c.* p. 250) agree in every respect with *H. pervicax*.

Ludwig (1883, *l. c.*) has shown that *H. pervicax*, *H. depressa*, and *H. mammiculata* should be associated together, and Théel (p. 221, *l. c.*) has suggested that *H. curiosa* and *H. fuscocinerea* are identical, a view in favour of which there seems to be considerable evidence.

H. argus Jaeger (Bohedschia) seems to be closely allied to this species.

HOLOTHURIA DIFFICILIS Semper. (Plate LII. fig. 3.)

Holothuria difficilis C. Semper, Reisen im Arch. Philipp. Bd. i. *Hol.* 1868, p. 92, Taf. xxx. fig. 21.

Distribution. Recorded from Samoa, Amboina, Pulo Edam, and Mauritius.

Six specimens from Rotuma, largest 62 mm. \times 20 mm., others about half this size.

The ground-colour of the smaller specimens is dark chocolate-brown.

They agree with Semper's short description and figures, to which I have nothing further to add ; both the dorsal papillæ and ventral feet possess supporting perforated plates. Buttons, as a rule, with 3 pairs of holes.

The species appears to me to be much more closely allied to *Actinopyga excellens* and *A. parvula* than to *Holothuria vagabunda*.

¹ *v.* Semper, Taf. xxvii.

HOLOTHURIA RUGOSA Ludwig. (Plate LIII. fig. 4.)

Holothuria rugosa H. Ludwig, Arb. zool.-zoot. Inst. in Würzb. Bd. ii. 1875, p. 110, Taf. vii. fig. 33.

Distribution. Recorded from Samoa, Pelew Is., New Britain, Waigeo Island.

One specimen from Rotuma, 125 mm. \times 22 mm., tentacular crown small (11 mm. in diameter). The five longitudinal furrows mentioned by Ludwig visible but not conspicuous, body flesh-coloured.

Deposits exactly as described and figured by Ludwig, but, as in the specimens described by Théel (p. 226), tables with more than 4 vertical supports to spire were exceptional.

HOLOTHURIA PARDALIS Selenka.

Holothuria pardalis E. Selenka, Z. f. w. Z. xvii. 1867, pp. 336, 337, Taf. xix. fig. 85; for synonymy, v. H. Ludwig, Sitzb. Ak. d. Wiss. Berlin, 1887, Heft 2, pp. 1226, 1227.

References. C. Ph. Sluiter, Natuurk. Tijd. v. Ned. Ind. xlvii. 1887.

H. Ludwig, Erg. d. Hamb. Magalh. Sammelreise, Lf. iii. 1898, p. 5.

In spite of Prof. Ludwig's separation of *H. subditiva* Selenka from *H. pardalis* Selenka, after Sluiter's examination of a large number of specimens from the Bay of Batavia all the evidence seems to point to the advisability of regarding them as one species, a view which has been upheld by Théel (as well as Sluiter).

Distribution. This species occurs all over the Indo-Pacific region from Zanzibar to Cocos Is., as well as in the East American littoral region (Surinam and Florida?). Prof. Ludwig (1887, *l. c.* p. 1242) described 2 specimens from Falkland Is., which would extend the range of the species into the Antarctic littoral region, but in 1898 (*l. c.*) he expresses some doubt as to the correctness of the locality recorded.

Several specimens from outer reef and mangrove swamp Funafuti: largest is 79 mm. \times 10 mm., diameter of tentacular crown 7 mm. when expanded; another specimen 39 mm. \times 9 mm., tentacular crown expanded 4.5 mm. in diameter; 20 tentacles (counted in 2 specimens). The specimens vary in colour in the way described by Sluiter. The buttons are very frequently incomplete and in those individuals examined they were irregularly distributed as in *H. subditiva*; the tables have, as a rule, a reduced spire, and their discs, which are invariably spinous, vary in size from .07 mm. to .04 mm. in diameter; curved rib-like rods occurred (as described) in the dorsal feet only.

HOLOTHURIA ATRA Jaeger, var. *AMBOINENSIS* Semper.

Holothuria amboinensis Jaeger, De Holothuriis, 1833, pp. 22, 23.

Holothuria atra Selenka; E. Selenka, Z. f. w. Z. xvii. 1867, p. 327, Taf. xviii. figs. 52, 53.

Holothuria amboinensis Semper; C. Semper, Reisen im Arch. Philipp. Bd. i. *Hol.* p. 92.

Var. of *H. atra* Jaeger (Théel & Sluiter), which = *H. floridana* Pourtalès and Selenka and *H. affinis* (*Microthele*) Brandt.

References. L. G. Pourtalès, Proc. Am. Assoc. vol. v. 1851, pp. 12, 13.

H. Ludwig, Z. f. w. Z. xxxv. 1881, p. 596.

H. Ludwig, Ber. Oberh. Ges. xxii. 1883, pp. 170, 171.

C. Ph. Sluiter, Natuurk. Tijd. v. Ned. Ind. xlvii. 1887, pp. 187, 188.

C. Ph. Sluiter, Semon's Zool. Forsch. in Austr. u. Mal. Arch. Bd. v. Lf. i. 1894, pp. 103, 104.

Ludwig (*l. c.*, 1883) seems to have first suggested that the two forms of this species, which were separated by Semper and which were from that time considered to be distinct species, were in reality well-marked colour-varieties of the same species, indistinguishable by any constant anatomical characters. Var. *amboinensis* is uniform dark brown or black, whereas in the other variety, which may be termed var. *affinis* = *H. atra* Jaeger (Théel and Sluiter), the ends of the feet and papillæ are whitish. In 1887 (*l. c.*) Sluiter had been unable to find intermediates between the two forms, but in 1894 (*l. c.*) he describes such among 5 individuals from Amboina.

Distribution. Both varieties are extremely widely distributed over the Indo-Pacific region and occur also in the circumtropical East American littoral region.

Two specimens from Rotuma and several from outer reef and lagoon, Funafuti, all belonging to var. *amboinensis*.

In four specimens dissected the following organization occurred:—

Length.	Breadth.	Cuvierian organs.	Polian vesicles.	Stone-canals.	Gonads.	Locality.
mm. 37	mm. 10	Absent.	2, fairly large.	3 in a group.	Undeveloped.	Rotuma.
46	20	Ditto.	4, ditto (7-9 mm. long).	16 ditto, various sizes.	Ditto.	Funafuti, outer reef or lagoon.
84	22	Ditto.	2, united at base, one much smaller than the other.	8 in a group.	Very small.	Ditto.
104	27	Ditto.	1 (12 mm. long).	5 in a group (each about 5 mm. long).	Large, arranged like a tassel on one side of mesentery.	Ditto.

HOLOTHURIA IMPATIENS Forskål (*Fistularia*).

Holothuria impatiens, P. Forskål, Descriptiones Animalium, 1775, pp. 121, 122.

Holothuria botellus Selenka; E. Selenka, Z. f. w. Z. xvii. 1867, p. 335, Taf. xix. figs. 82-84.

References. C. Semper, *Reisen im Arch. Philipp.* Bd. i. *Hol.* 1868, p. 82, Taf. xxii.

H. Ludwig, *Arb. a. d. zool.-zoot. Inst. in Würzb.* 1875, p. 112, fig. 51.

H. Théel, 'Challenger' *Holothurioidea*, ii. p. 179, pl. vii. fig. 9.

H. Östergren, *Zool. Anz.* Bd. xxi. 1898, pp. 233-237.

Distribution. This species is extremely widely distributed throughout the circumtropical zone; it is recorded from the East American region, Mediterranean subregion (Dalmatia &c.), and the greater part of the Indo-Pacific region.

Several specimens from Rotuma from 29 mm. × 11 mm. to 106 mm. × 23 mm.

The colour is characteristic, the dorsal violet-brown blotches, as a rule, coalescing to form transverse bands; but in one specimen the blotches are quite distinct, forming two longitudinal rows, as in the two specimens described by Ludwig from Tahiti and Surinam respectively.

The deposits are typical and I have no opportunity of confirming Östergren's view that *H. aphanes* Lampert is the young form of *H. impatiens* Forskål.

In four specimens dissected the arrangement shown in the following table occurred:—

Length.	Breadth.	Cuvierian organs.	Polian vesicles.	Stone-canals.	Gonads.	Locality.
mm. 106	mm. 28	Very bulky, white.	2 (each over 20 mm. long).	1, free.	Very large, with short thick branches.	Rotuma.
65 55	15 25	(Eviscerated.) Very bulky, white.	Ditto. Ditto.	Ditto. Ditto.	(Eviscerated.) Very large, with short thick branches.	Ditto. Ditto*.
29	11	Bulky, white.	1 (5 mm. long).	Ditto.	Undeveloped.	Ditto.

* *Remark.*—Tentacle ampullæ long.

HOLOTHURIA MONACARIA Lesson.

Holothuria monacaria R. P. Lesson, *Centurie Zoologique*, 1830, p. 225, pl. 28.

References. H. Théel, 'Challenger' *Holothurioidea*, ii. 1885, pl. viii. fig. 10.

C. Ph. Sluiter, *Natuurk. Tijd. v. Ned. Ind.* Bd. xlvii. 1887, p. 189.

H. Ludwig, *Zool. Jahrb. Syst.* iii. 1888, p. 806.

Distribution. The species is widely distributed over the Indo-Pacific region of the circumtropical zone.

Several specimens from Rotuma, average about 40 mm. × 12 mm. The colour of all the specimens is very striking and constant (*v. Sluiter & Ludwig, l.c.*), the warts on which the papillæ are erected being distinctly yellow as described by Ludwig.

In three specimens dissected the following variations occurred:—

Length.	Breadth.	Cuvierian organs.	Polian vesicles.	Stone-canals.	Gonads.	Locality.
mm. 50	mm. 14	? (Eviscerated.)	1 (15 mm.).	1 (free for greater part).	? (Eviscerated.)	Rotuma.
36	13	Small.	2 (one much longer than the other).	Ditto.	Undeveloped.	Ditto.
30	11	Small.	2 (one little longer than the other).	Ditto.	Undeveloped.	Ditto.

HOLOTHURIA MACULATA Brandt.

(Genus *Sporadipus*, subgenus *Acolpos*) *v. H. Ludwig, Z. f. w. Z.* xxxv. 1881, p. 595.

Holothuria arenicola Semper; C. Semper, *Reisen im Arch. Philipp.* Bd. i. *Hol.* 1868, p. 81, Taf. xx., Taf. xxx. fig. 13, Taf. xxxv. fig. 4.

Distribution. Recorded from greater part of Indo-Pacific region and also from East and West American regions of circumtropical zone.

Two specimens from outer reef, and one from shore of lagoon, Funafuti, up to 126 mm. × 22 mm.; all quite typical (internal anatomy not examined).

HOLOTHURIA VAGABUNDA Selenka.

Holothuria vagabunda E. Selenka, *Z. f. w. Z.* xvii. 1867, Taf. xix. figs. 75, 76.

Holothuria lagena Haacke; H. Ludwig, *Ber. Oberh. Ges.* xxii. 1883, pp. 174, 175.

References. H. Théel, 'Challenger' *Holothurioidea*, ii. 1885, p. 180, pl. vii. fig. 10.

R. Koehler, *Mém. Soc. Zool. France*, viii. 1895, pp. 383, 384.

H. Ludwig, *Ergeb. d. Hamb. Magalh. Sammelreise*, Lf. iii. 1898.

H. Ludwig, *Fauna Chilensis*, Heft ii. p. 449.

Koehler, after examining specimens from different localities, proposed to unite *H. vagabunda* and *H. lagena*.

Distribution. This species is recorded from all over the Indo-Pacific region of the circumtropical zone, from as far E. as the Cocos Islands and Peru to as far W. as the E. of Africa: Lampert gives the locality Adelaide (Berlin Museum); and if this refers to

the port of that name in S. Australia it would extend its range into Ortmann's Antarctic littoral region, although Ludwig does not include the species in his list of Antarctic Holothurians.

One specimen, 140 mm. \times 32 mm., from outer reef, Funafuti: colour uniform brown; the dorsal appendages distinctly more papilliform than the ventral; deposits typical; Cuvierian organs present.

DENDROCHIROTE.

PSEUDOCUCUMIS AFRICANA Semper. (Plate LIII. fig. 5.)

Cucumaria africana C. Semper, Reisen im Arch. Philipp. Bd. i. *Hol.* p. 53, Taf. xv. fig. 16 (figure inaccurate, *v.* Ludwig, 1888).

Cucumaria assimilis Bell = *Ps. théeli*, Ludwig = *Ps. africana* Ludwig.

For more detailed synonymy, *v.* R. Koehler, Rev. Suisse de Zool. iii. 1895, pp. 276, 277.

References. H. Ludwig, Arb. a. d. zool.-zoot. Inst. in Würzb. 1875, p. 90, fig. 17 (*Ps. acicula*).

F. J. Bell, Proc. Zool. Soc. 1884, pp. 253-258 (*Amphicyclus japonicus*).

K. Lampert, Die Seewalzen, 1885, pp. 254, 255 (*Ps. intercedens*).

H. Ludwig, Zool. Jahrb. Syst. ii. 1887, pp. 25-27 (*Ps. intercedens*).

H. Ludwig, Sitz. k. Ak. d. Wiss. Berlin, 1887, Heft ii. pp. 1236-1241, figs. 12-16 (*Ps. théeli*).

H. Ludwig, Zool. Jahrb. Syst. iii. 1888, pp. 815-817 (*Ps. africana*).

H. Ludwig, Bronn's Klassen, Bd. ii. Abth. 3, Buch 1, 1889-92, p. 95, figs. 11, 12, and p. 348.

W. Bateson, Materials for Study of Variation, 1894, pp. 432-435.

H. Östergren, Zool. Anz. Bd. xxi. 1898, p. 135.

The genus *Pseudocucumis* was first defined by Ludwig (*l. c.*, 1875) on the single species *Ps. acicula*, and with a few alterations, necessitated by the subsequent description of other species, this definition was used by him in Bronn's 'Klassen' (*l. c.* p. 348) to include the genus *Amphicyclus* Bell.

Distribution. The genus, of which five species are known, is recorded from the circumtropical Indo-Pacific region, and from the west coast of Norway. *Ps. africana* has been recorded from as far W. as Zanzibar to as far E. as Fiji.

Seven specimens from Rotuma, averaging about 22 mm. \times 9 mm.

I have nothing to add to Ludwig's full and accurate description (1887, *l. c.*, *Ps. théeli*), except to record certain variations in tentacular symmetry which appear to me of interest, especially in relation to the arrangements occurring in other species of the genus. *Ps. mixta* Östergren has 5 pairs of larger alternating with 5 pairs of smaller tentacles; the latter are radial in position and vary in size; they seem from Östergren's description to be arranged in bilateral

symmetry, except the mid-ventral radial pair, the left of which is smaller than the right: no mention is made of the tentacles forming more than one circle, but as they were in a retracted condition this may have been overlooked.

Ps. acicula Semper (Ludwig, 1875, *l. c.* fig. 17 *b*) also possesses 20 tentacles, of which 15 (10 large and 5 small) form an outer circle surrounding 5 smaller tentacles corresponding to the radii (*v.* Diagram I.) (from Bronn, *l. c.* p. 95).

Ps. intercedens Lampert.—Lampert (*l. c.*) describes 18 tentacles, of which 5 form an inner circle, the inner tentacles being as large

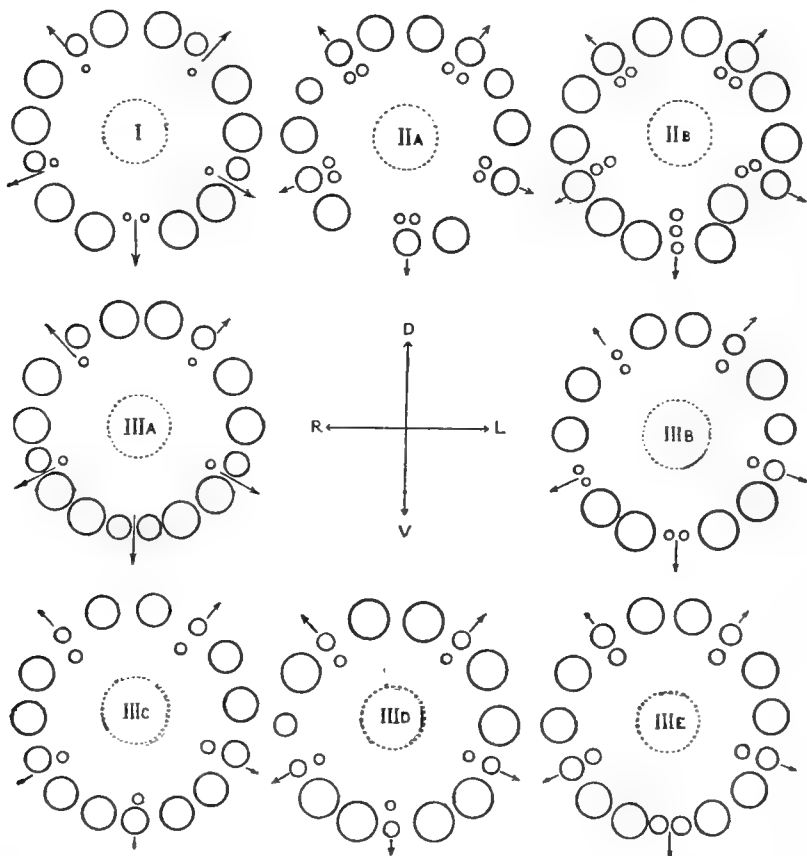

Diagram of oral tentacles of *Pseudocucumis*.

The tentacles are supposed to be viewed from in front, the mouth being represented in the centre. The relative sizes of the circles correspond approximately to the relative length and breadth of the tentacles, the relative distances being also approximately correct. The arrows indicate the position of the 5 radii.

Fig. I. *Pseudocucumis acicula* (Semper), after Ludwig in Bronn's 'Klassen,' *l. c.* p. 96.

Fig. II. *Ps. japonica* (Bell). A, B. From two specimens in the British Museum.

Fig. III. *Ps. africana* (Semper). A. After Ludwig in Bronn's 'Klassen,' *l. c.* p. 96; B, C, D, E. From specimens in the present collection.

as the smallest of the outer tentacles (if the inner circle consisted of 5 pairs, a condition similar to that which I found in a specimen of *Ps. japonica*, v. Diagram II., would result).

Ludwig (1887, *l. c.*) described a specimen in which the arrangement and number of tentacles were quite different, an inner circle of 5 pairs being surrounded by an outer circle of 20 larger tentacles arranged in 5 groups of 4, making 30 altogether.

Ps. japonica Bell.—In two specimens in the British Museum I find 25 and 23 tentacles respectively, arranged as in Diagrams II. A and II. B.

Ps. africana Semper possesses 20 tentacles. Ludwig (*l. c.*, 1887, *Ps. thélii*) described in two examples the arrangement shown in Diagram III. A, which is taken from Bronn, *l. c.* p. 95. 4 out of the 7 specimens were preserved in formol with expanded tentacles, and in these specimens the arrangement is as shown in Diagrams III. B, C, D, E.

The interest of these variations seems to me to lie chiefly in two directions: (1) the individual variations follow the same lines as the specific differences, and in consequence they indicate the sort of stages by which it is possible for one type of tentacular arrangement to be converted into other types without any "breaches of continuity"; and (2) the relation of the minor tentacular symmetry to the major symmetry of the body is seen in the bilateral symmetry of the tentacles combined with a radial and interradian arrangement.

It may be interesting to note the presence of developing Gastropod eggs, crowded in the usual mucoid (?) capsules, and fixed to the surface of one of the specimens: the capsules were circular in outline and rather more than 1 mm. across, each containing over 100 embryos; whether these belong to some parasitic genus, e. g. *Eulima* or *Stylifer*, or to a free-living form, I have no opportunity of discovering.

SYNAPTIDÆ.

CHIRIDOTA LIBERATA Sluiter.

Chirodota liberata C. Ph. Sluiter, *Natuurh. Tijds. v. Ned. Ind.* xlvii. 1887, pp. 212, 213, Taf. ii. figs. 44, 45.

Distribution. Sluiter's specimens were found creeping on dead or living branches of coral in the Bay of Batavia, and a single specimen is recorded from Pulo Edam.

One specimen from Rotuma, 28 mm. × 4 mm., 12 tentacles, each with 8 to 10 pinnæ, the two longest forming a terminal pair; wheel-papillæ in single row on two ventral interambulacra, distributed more numerous on 3 dorsal interambulacra as in *C. rigida*. Wheels .05 mm. diameter, owing to partial solution no details could be made out; no deposits in body-wall outside wheel-papillæ, but within the papillæ the characteristic C-shaped bodies figured by Sluiter occur; these at first sight appear like broken rims of wheels,

but are undoubtedly separate deposits; calcareous ring not closely examined; 5 short retractor muscles and several Polian vesicles occur.

CHIRIDOTA INTERMEDIA, sp. nov. (Plate LIII. figs. 6 a-d.)

References. H. Ludwig, Arch. de Biol. t. ii. 1881, pp. 41-58, pl. iii. (*C. rotifera*).

R. Semon, Mitth. a. d. zool. Stat. zu Neap. vii. 1887, p. 272, Taf. x.

H. Ludwig, Z. f. w. Z. liv. 1892, p. 350, Taf. xvi.

A. Dendy, Journ. Linn. Soc., Zool. xxvi. 1897, p. 49.

Several specimens from the mangrove swamp, Funafuti, average about 22 mm. \times 4 mm.: largest under 3 cm. long. Colour whitish, transparent near posterior end of body. 12 or 13 tentacles (out of 4 individuals, 2 had 12 and 2 had 13); pinnæ subequal, about 7 in number, the proximal pinnæ being situated some distance from base, terminal ones *not* forming a pair longer than rest.

Wheel-papillæ in a somewhat irregular single row in each interambulacrum (except at anterior end, where they are more crowded); the two ventral interambulacra contain very few papillæ, being often quite devoid of them in the middle of the body (cf. *C. laevis*); the papillæ are opaque, white, and rather conspicuous. Wheels and curved rods present. The wheels (figs. 6 a, b) are very similar to those of other species of *Chiridota*; a cover-plate is present over the basal plate and its centre is closed; there is no central pillar between the base and cover-plate; the upper rim only of the wheel is toothed, and there is a distinct notch in the cover-plate between its radii (= "Speichen-Platten," Ludwig). Dendy (*l. c.*) described the fully-developed wheels of *Trochodota dunedinensis* (*Chiridota dunedinensis* Parker) as situated with their faces parallel to the surface of the body, and so arranged that the toothed edge is always directed outwards; in consequence he uses the terms "outer" and "inner" faces of the wheels: in *C. intermedia* the arrangement is different; the wheels are arranged in each papilla so that the toothed edge of the wheel is nearly always directed away from the centre of the papilla, so that those wheels on the inside of each papilla have the toothed edges facing the opposite way to those on the outside of the papilla. It seems better, therefore, to use the arbitrary terms "upper" and "lower" in the sense in which Ludwig has already used them, so that they are applicable to any arrangement of the wheels in the body-wall. The rods (fig. 6 a) are present all over the body and are thickened at the ends and in the middle, the ends being unbranched except in the tentacles (fig. 6 d), where they are also longer and narrower (cf. *C. liberata* and *C. rotifera* and tentacular deposits of *C. pisanii*); abnormalities of the rods occasionally occur either by the development of a branch from the middle of the rod forming a triradiate spicule, or they may very rarely become S-shaped, a condition which is normal in *C. contorta*, *C. australiana*, *Trochodota purpurea* (= *studerii*), and *Anapta*

japonica. Calcareous ring consists of 12 pieces, 5 radial and 7 interradial, the latter being arranged symmetrically on each side of the dorso-ventral line (1 in each ventral interradius, 1 in mid-dorsal interradius, and 2 in each dorso-lateral interradius); the 5 radial pieces are each pierced by a hole (or seldom notched as in *C. liberata*). Several Polian vesicles (about 5) and a single stone-canal fixed to mesentery occur.

SYNAPTA GODEFFEROYI Semper.

(Genus *Euapta* Östergren), C. Semper, Reisen im Arch. Philipp. Bd. i. *Hol.* p. 231, Taf. xxxix. fig. 13.

Reference. C. Ph. Sluiter, Semon's Zool. Forsch. in Austr. u. Mal. Arch. Bd. v. Lf. 3, 1894, p. 105.

Distribution. Mauritius, Pelew Is., Thursday Is., Fiji, Samoa, Caroline Is.; it thus ranges over a considerable part of the Indo-Pacific region.

Two specimens from Rotuma: largest 180 mm. \times 13 mm., length of tentacles about 13 mm.; 15 tentacles.

Deposits &c. agree with description and figures by Semper, but the malformations of the anchors did not seem to occur (*cf.* Sluiter):

Two smaller specimens from Rotuma, one of which is 35 mm. \times 5 mm., appear to be the young of this species: the tentacles I am unable to count because of their condition, but the deposits agree exactly with the larger forms; colour is different, the body being speckled with silver-grey markings.

SYNAPTA KEFERSTEINI Selenka.

(Genus *Chondrodea* Östergren), E. Selenka, Z. f. w. Z. xvii. 1867, p. 360, Taf. xx. figs. 120, 121.

References. C. Semper, Reisen im Arch. Philipp. Bd. i. *Hol.* pp. 14, 15, Taf. v. fig. 24, p. 230, Taf. xxxix. fig. 11.

H. Ludwig, Zool. Jahrb. iii. Syst. 1888, p. 818.

C. Ph. Sluiter, Semon's Zool. Forsch. in Austr. u. Mal. Arch. Bd. v. Lf. 3, 1894.

H. Östergren, Öfvers. af Kongl. Vet.-Ak. Förhandlingar, Årg. lv. No. 2, 1898, p. 111.

Distribution. Recorded from Sandwich Is., Samoa, Amboina, and Kosseir (Red Sea).

Two specimens (one imperfect) from Rotuma, one 70 mm. \times 10 mm.

Ludwig (*l. c.*) notes the variation in number of tentacles in this species. In these specimens there are 25 in each specimen.

I have nothing to add to the description of Selenka and Semper, revised by Ludwig: in Ludwig's specimens the seventh hole of the anchor-plates has a dentate margin, whereas in those examined by Selenka and Semper the margin appears to have been smooth; these specimens are interesting in the fact that they possess anchor-plates of both kinds, intermediate conditions of all grades being very common.

SYNAPTA OOPLEX Marenzeller.

Synapta ooplax v. Mar. Verh. zool.-bot. Ges. Wien, xxxi. 1881, pp. 122, 123, Taf. iv. fig. 1.

Reference. H. Östergren, Zool. Anz. Bd. xxi. 1898, pp. 233-237.

Distribution. Recorded from Japan and Loyalty Is.

Three specimens from beach of lagoon, Funafuti; largest 135 mm. \times 5 mm.

The body is nearly circular in section, with the radii visible as 5 white indistinct longitudinal bands; colour whitish, without the pink tinge which typically characterizes the species.

In one specimen the deposits were quite typical, in the second they were completely dissolved, and in the third somewhat disintegrated, anchors alone were present (no anchor-plates or biscuit-shaped spicules); I believe this condition to be due to partial artificial solution, but as Sluiter has described for *Synapta kefersteini* a somewhat similar condition of partial decalcification, which he believes to be natural, it seemed worth while to mention the fact; Östergren has also laid stress on a similar process taking place in other Holothurians.

EXPLANATION OF THE PLATES.

PLATE LII.

Fig. 1. *Actinopyga parvula* Selenka, p. 836.

a. Entire ventral view. \times 4.

b. Tabular deposits. \times 250.

c. Button-like deposits and sieve-plates. \times 250.

d. Spiny rods in the dorsal feet.

Fig. 2. *Holothuria fuscocinerea*, var. *pervicax* Selenka, p. 837.

a. Entire side view. \times 1½.

b. Deposits (excluding tables). \times 250.

Fig. 3. *Holothuria difficilis* Semper, p. 838. Entire side view. Nat. size.

PLATE LIII.

Fig. 4. *Holothuria rugosa* Ludwig, p. 839. Entire side view. Nat. size.

Fig. 5. *Pseudocucumis africana* Semper, p. 843. Entire side view. \times 3.

Fig. 6. *Chiridota intermedia*, sp. nov., p. 846.

a. Wheel from below. \times 850.—The teeth on the upper edge are seen through the rim and the centre of the basal plate is shown in focus. *bp.*, basal plate; *cp.*, cover-plate; *cpc.*, centre of cover-plate; *cpr.*, radius of cover-plate; *ue.*, upper edge of wheel (toothed); *le.*, lower edge of wheel (smooth); *bpr.*, radius of basal plate; *sp.*, spoke of wheel between point of junction of *cpr.* and *bpr.* and rim of wheel; 1-6 opposite ends of spokes seen on rim of wheel.

b. Wheel on edge, same lettering as *a.* \times 850. The basal plate (*bp.*) is seen dimly through the cover-plate (*cp.*) in the centre.

c. Rods in body-wall. \times 300.

d. Rods in tentacles. \times 300.

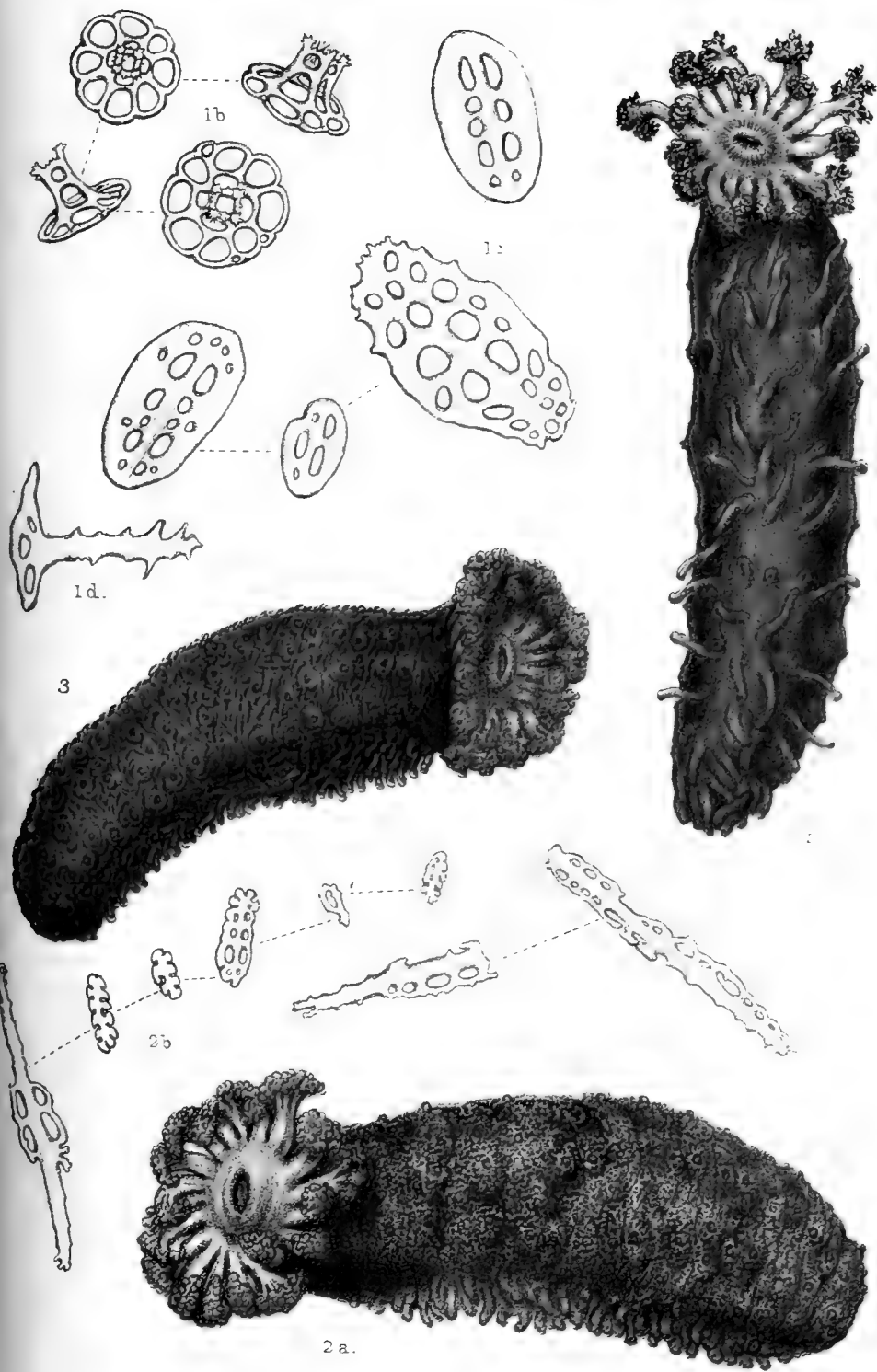



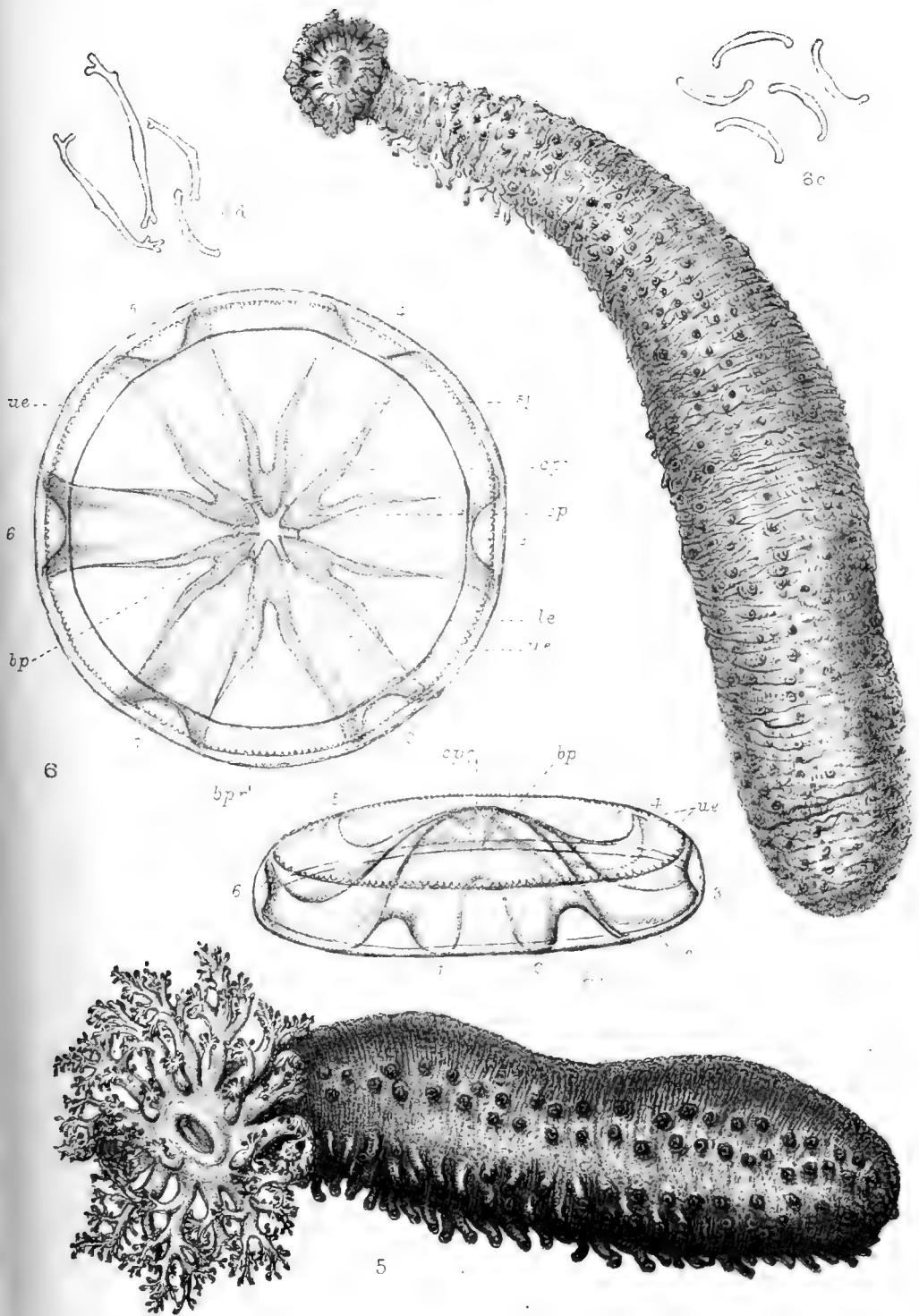

C. Berjeau chr lith

West, Newman imp.

Holothurians from Funafuti and Rotuma.



10. On the Actinogonidiate Echinoderms collected by
Mr. J. Stanley Gardiner at Funafuti and Rotuma.
By F. JEFFREY BELL, M.A., F.Z.S.

[Received October 13, 1898.]

The Echinoderms, other than Holothurian forms, collected by Mr. Stanley Gardiner do not present so many points of interest as those to which Mr. Bedford's paper is devoted (see p. 834). I very much regret that the recent demands on my time prevented me from availing myself as fully of Mr. Gardiner's kindness as I at first hoped, but I am glad to have been able to introduce Mr. Bedford to original systematic work.

I. CRINOIDEA.

The only Crinoid obtained was an *Actinometra* from the outer part of the reef at Rotuma, which I have not been able to specifically determine.

II. ASTEROIDEA.

The only Asteroids collected were *Culcita grex* M. Tr.; *Gymnasterias carinifera* Lamk.; *Ophidiaster cylindricus* Lamk., which was taken both at Rotuma and Funafuti; and a number of most interesting and instructive examples of the 'comet-form' of *Linckia* (probably both *L. multiforis* and *L. miliaris*) from Rotuma, which will be of great service to workers at this extraordinary means of reproduction.

III. OPHIUROIDEA.

The species found were all common and well-known:—

1. *Pectinura gorgonia* M. Tr. Rotuma.
2. *Ophiolepis cincta* M. Tr. Rotuma.
3. *Ophioplocus imbricatus* M. Tr. Rotuma.
4. *Ophiactis savignii* M. Tr. Funafuti, outer reef.
5. *Ophiocoma erinaceus* M. Tr. Funafuti, outer reef.
6. „ *scolopendrina* Ag. Funafuti, outer reef, and also Rotuma.
7. *Ophiarthrum elegans* Peters. Rotuma.
8. „ *pictum* Lyman. Rotuma.

IV. ECHINOIDEA.

These also are common reef-species:—

1. *Cidaris metularia* Lamk. Rotuma.
2. *Echinothrix diadema* L.¹ Rotuma and Funafuti.
3. *Triploneustes variegatus* Leske. Rotuma.

¹ See Lovén, Bih. Sv. Vet.-Akad. Hdlgr. xiii. 4, no 5, p. 127.

4. *Echinometra lucunter* Leske. Rotuma and Funafuti, lagoon, 15-25 fms.
5. *Echinometra oblonga* de Bl. Funafuti, lagoon, 15-25 fms.
6. *Heterocentrotus mammillatus* Leske. Funafuti.
7. *Echinoneus cyclostomus* Leske. Funafuti, lagoon, 18 fms., and Rotuma.
8. *Laganum depressum* Less. Funafuti, lagoon, 15-25 fms.
9. *Maretia planulata* Lamk. Funafuti, lagoon, 15-25 fms.
10. *Brissus unicolor* Leske. Rotuma, reef.

It will be seen that all the species are common and widely distributed, and that there is no occasion to dilate at any length on the subject.

11. On a new Antelope of the Genus *Hippotragus*.

By OSCAR NEUMANN.¹

[Received November 1, 1898.]

I propose to designate a new geographical form of the Roan Antelope (*Hippotragus equinus*) from East Africa by the name of:—

HIPPOTRAGUS RUFO-PALLIDUS, sp. nov.

General markings as in *H. equinus*, but the colour without any brownish or greyish tints, being of a pale reddish, lighter in some specimens and more red in others, but never of a dark red as in the West-African form.²

The legs of *H. rufo-pallidus* are of a dark reddish colour, the oldest specimen in my collection having black markings on the legs. The base of the tail is black, this colour extending to the hind part of the back. The ears are tufted, but the hairs are not so long as in *H. bakeri*.

Hab. German and British East Africa.

I believe that all the Roan Antelopes mentioned from German and British East Africa (Uganda Protectorate), also that which Mr. Hinde shot at Machako's (cf. de Winton, P.Z.S. 1898, p. 127), belong to this species. I am, however, of opinion that the Antelope is very rare in these countries, as I met with it only on one occasion during the two years of my travels in East Africa. This was a herd, out of which I shot five specimens, unfortunately all females, on the 24th September, 1893, on the upper part of the River Bubu, about halfway between Irangi and Mount Gurui. When approached the herd did not make off at full speed but

¹ Communicated by the Secretary.

² I am quite of the opinion of Herr Matschie that it is impossible to attribute the *Antilope kob* of Erleben to a *Hippotragus*, as it must be either an *Adenota* or a *Bubalis*. The original French description of Buffon indicates a *Bubalis*, while the plate represents an old *Adenota kob*, and the plate of *Antilope kob* depicts a young specimen of the same animal.

trotted or galloped away in a slow canter, so that I was able to follow them for about twenty minutes by running, and I believe I could have shot more of them had I not become quite exhausted.

The following are the measurements of my four horns of *Hippotragus rufo-pallidus*, the fifth being that of quite a young animal:—

	In a straight line.	Round the curve.	Circumference at the base.	From tip to tip.
1. ♀	18½ inches.	21½ inches.	6¾ inches.	9¾ inches.
2. ♀	16½ "	19¼ "	6¾ "	8½ "
3. ♀	16¼ "	18¼ "	6½ "	8¾ "
4. ♀ jr. ...	12¾ "	13¾ "	5¾ "	7½ "

November 29th, 1898.

W. T. BLANFORD, Esq., F.R.S., V.P., in the Chair.

Mr. P. Chalmers Mitchell, F.Z.S., exhibited and made remarks on some etched studies of the young Orang-Outangs recently living in the Jardin des Plantes at Paris.

Mr. G. A. Boulenger exhibited a dancing-stick from New Guinea, marked "Native name *Gooapey*, from Dameracura, mouth of Fly River," to which two imperfect skulls of the rare Chelonian *Carettochelys insculpta* Ramsay were attached as ornaments or charms. This object had been acquired at Stevens's sale-room by the well-known dealer Mr. Gerrard, and the skulls had been correctly identified by his father, Mr. Edward Gerrard, lately of the British Museum, so distinguished for his great experience of osteological specimens.

The chief interest of the exhibit lay in the fact that since the description of *Carettochelys* in 1886, from a single stuffed specimen from the Fly River, preserved in the Sydney Museum, nothing had been heard of the occurrence of this extraordinary Turtle, the affinities of which are still uncertain. The specimens exhibited confirmed the account given by Baur in 1891, from photographs of the imperfect skull extracted from the Sydney skin, and afforded the further information that the pterygoids are not turned up in front, being in fact absolutely similar to those of the *Trionychidæ*, and that the premaxillary is single, a feature otherwise restricted, among Chelonians, to *Chelys* and the *Trionychidæ*.

Mr. Boulenger also exhibited a large female specimen of the Sea-snake *Distira stokesii* Gray, measuring 1½ metres. It had been caught by Mr. F. W. Townsend in August last, floating on the surface in Kurrachee harbour, entirely covered with a thick growth of green weeds, which had been kindly determined by Mr. Vernon H.

Blackman to be referable to 2 or 3 species of *Ulva* and 2 or 3 species of *Enteromorpha*, both common genera of green algæ. A similar case of dense vegetable growth on a water-snake had been observed by Peters on the Siamese *Herpeton tentaculatum*, and recorded by him in 1882. The present specimen, on being cut open, had been found to contain 12 well-developed young, measuring from 30 to 42 centimetres, in addition to two undeveloped ova forming part of the same chain and situated between the fertile ones.

The Secretary read some extracts from a letter received from Mr. John S. Budgett, F.Z.S., who had gone to the Gambia for the winter on a scientific expedition on behalf of the Society. It was dated Bathurst, Nov. 5th, and stated that he had arrived there on the previous day, and proposed to start up the river on the following Tuesday for M^cCarthy's Island, where he would collect fishes and birds. The Antelopes were now in the uplands and were not expected to come down to the river until the dry season commenced.

Mr. C. W. Andrews exhibited and made remarks upon some bird-remains from the Lake-dwellings of Glastonbury, Somersetshire. The specimens included numerous bones of a large Pelican which was identified as *Pelecanus crispus*; most of the remains were those of young birds which had been probably killed for food. The date of the settlement had been fixed as between 300 B.C. and the Roman occupation. Amongst the associated forms were the Beaver, Otter, Pine-Marten, Crane, Wild Swan, a large Eagle, Cormorant, Coot, and a number of small birds which had not been determined.

Mr. Oldfield Thomas, F.Z.S., read a letter which he had received from Señor Ameghino, C.M.Z.S., on the subject of the newly discovered mammal *Neomyiodon*¹, giving further information, obtained from the Indians, as to its distribution, characters, and habits.

The following papers were read:—

1. Further Notes on the Amazonian *Lepidosiren*.
By Dr. EMIL A. GOELDI, C.M.Z.S., Pará.

[Received October 8, 1898.]

The unexpected discovery of *Lepidosiren paradoxa* on the island of Marajó, as announced in my previous communication to the Society on this subject (see Trans. Zool. Soc. vol. xiv. p. 414), made me desirous of submitting this locality, only two days' sailing from Pará, to further exploration. At my public lecture (held on June 3rd, 1897²) it was easy to call general attention to the

¹ See 'Nature,' vol. lviii. p. 549 (1898).

² Boletim do Museu Paraense, tom. ii. fasc. 2, p. 247.

subject and to insist on the necessity of diminishing our deficiency of actual knowledge relative to the biology of *Lepidosiren*. I mentioned particularly the great probability—even at that time I called it quite a certainty—that the analogy in the habitat of the African *Protopterus* with that of the South-American *Lepidosiren* would be accompanied by a correspondence in the mode of life, especially as regards its lethargy during the dry season. If my hopes and expectations have not been realized so far in this point in regard to the Amazonian *Lepidosiren*, it must be attributed more to climatic difficulties during recent years than to the want of goodwill and exertions. It seems that the critical period (presumably caused by cosmic agents), which regularly brings excessive dryness to Ceará and some of the neighbouring States of North Brazil, and exceptional inundations to Lower Amazonia, is approaching again or has already begun. The fact is, that the water-level in Marajó and on the Lower Amazon, throughout the localities where specimens of *Lepidosiren* are caught, was considerably higher in 1897 than usual, and the papyrus-meadows (“*pirisál*,” from “*piri*” = papyrus), which, at least partially, dry up in normal years, remained under water all that year. The same fact repeats itself this year 1898—the summer in Pará having begun only about the middle of June, at least a month after the usual time.

These circumstances did not permit definite investigations about the summer-life of *Lepidosiren*. But the efforts which were made brought, at least, one advantage. I got two more specimens of the singular Dipnoan, both uninjured, though not living. One of the specimens lived for some hours after its capture, but did not survive the transport to Pará. Both are males, the villi of the posterior extremity being more distinctly developed in the smaller specimen than in the larger. The measurements are:—

Specimen *f*. Total length 53 cm. ; circumference 13 cm.
Anus on the left side.

Specimen *g*. Total length 51 cm. ; circumference 12½ cm.
Anus on the left side.

The colour is the same as was described before. These two specimens of 1897, together with the five previously noticed, make the total number of seven specimens of the Amazonian form of *Lepidosiren paradoxa* obtained by me from 1894 up to this time. These two new specimens were found exactly in the same locality as the Marajó *Lepidosiren* captured in May 1896, and sent to the British Museum, *i. e.* at Fazenda Dunas, Cape Magoary, a property belonging to Dr. Vicente Chermont de Miranda, civil engineer. The exact spot is distant only half an hour from the Fazenda building¹.

I think it may be of some interest to describe more exactly the physical features of a locality which in two years has furnished three specimens of this Dipnoan. For this purpose I send a

¹ Confer ‘Boletim do Museu Paraense,’ vol. i. fasc. 1, p. 438 *et seqq.*

photograph (fig. 1) representing its aspect in the beginning of September 1896, the period of relative low water. The photograph shows a typical "pirisál" (papyrus-meadow), cut transversely by a canal about 2 metres wide and generally some 6 feet deep. In the background, at some distance, several persons are seen waiting for a canoe. On the left hand, near the middle of the scene, a small pool is seen between the roots of some smaller "piri" bushes. From this pool came the first *Lepidosiren*; the other two specimens were also obtained nearly at the same spot.

Fig. 1.



Pirisál at Dunas, Marajó, in September 1896.

Our living specimen of *Lepidosiren* from Obydos, which has survived now more than a year in captivity, and has somewhat changed its habits, as it now accepts food regularly (mandioca-roots), and turns aggressively against the fingers placed on the glass walls of its aquarium, developed during my 8 months' absence in Southern Brazil a very curious character. The free end of its fore-limbs now shows slender ramifications, somewhat like deer-

antlers in form. The right fore-limb (fig. 2) has two principal branches, the oral with three smaller branches, the aboral with two only. The opposite left fore-limb (fig. 3) has two lateral branches, not ramified, and directed downwards, instead of upwards as on the right limb.

Fig. 2.

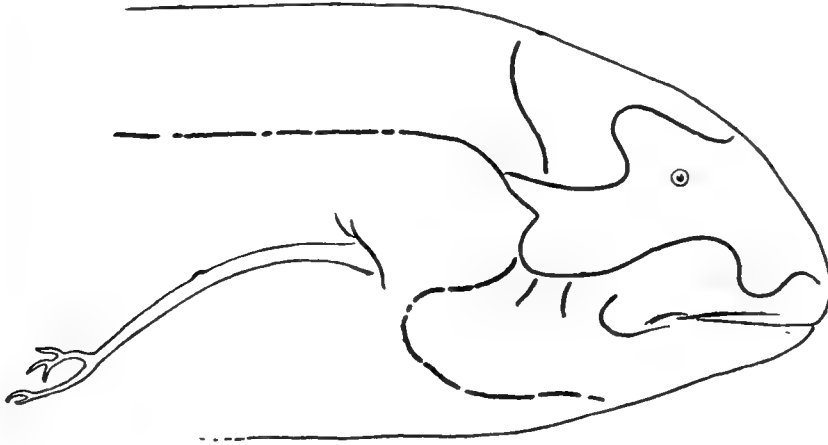

Fig. 3.

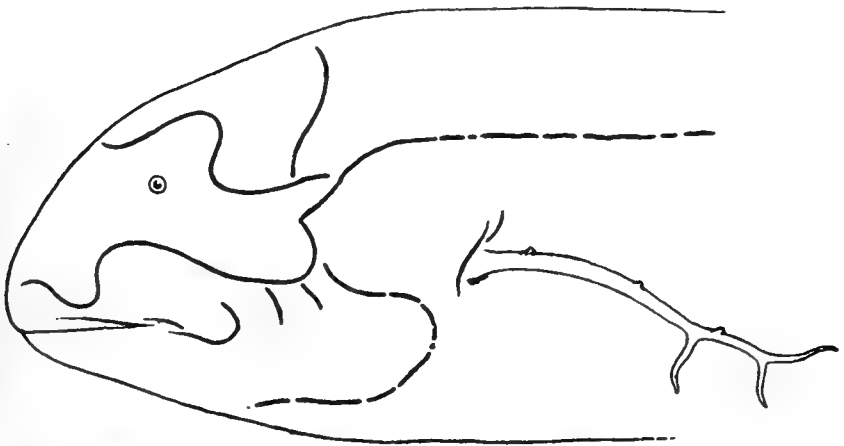

Fig. 2. Head of living *Lepidosiren*, showing the ramifications of the fore-limb.
 Fig. 3. The same on the left side. The three slight eminences on the upper side of the limb show the commencements of further appendages.

What is the signification of these formations? I think I am right in interpreting them as *casual* and *accessorial* appendages with respiratory functions—a sort of very singular secondary or complementary external gills, produced mainly by the necessity of increasing the respiration-surface during life in a small aquarium. I cannot find any other plausible explanation of the phenomenon.

It is known that the African *Protopterus* occasionally exhibits some

short and insignificant filaments arising from the gill-opening and situated at the base of the fore-limb. They are generally considered as external branchial appendages undergoing atrophy. According to Dr. Günther they merit the rank of a specific character in comparison with the Australian *Ceratodus* and the South-American *Lepidosiren* ('Introduction to the Study of Fishes,' p. 355; 'Catalogue of Fishes in the British Museum,' vol. viii. (1870) p. 322). Prof. Lankester has recently expressed his doubts about the specific value of the characters of the branchial appendages of *Protopterus*, stating, on the one hand, that moderate-sized specimens of *Protopterus* do not possess external gills, and supposing, on the other hand, that small specimens of *Lepidosiren* (not having been yet examined) may possess such gills (see Trans. Zool. Soc. xiv. p. 18).

As the matter stands, the facts observed in our living specimen of *Lepidosiren* become of much interest. Supposing that I am right in my opinion concerning the physiological signification of these strange appendages, we must be surprised at the analogy of the case with that of certain Amphibians of the section Urodela. From the experiments of Mademoiselle De Chauvin¹, we know that the celebrated Mexican *Amblystoma* remains in the Sireon-state, characterized by external branchiæ, under the artificial constraint of water-life. Other experiments of the same observer have shown² that the ovine larvæ of *Triton alpestris* throw off their excessively developed external branchiæ, replacing them rapidly by new ones, better adapted to the casual conditions of a life in water—which for this species is not the normal one. We know further³, that Kneeland observed the extreme facility with which two specimens of *Menobranchus lateralis* regenerated their external branchiæ, when bitten away by fishes inhabiting the same aquarium. Ulterior secondary development of external branchiæ is thus a fact not isolated in the animal kingdom. Does the consideration that such cases are not confined to the Amphibia really involve an insuperable difficulty? I do not think so. In its mode of life *Lepidosiren* is, from the biological standpoint, as true an amphibian as these animals, which belong properly to that class according to present scientific views. And reflecting that identical external conditions of life will naturally produce similar physiological functions, and therefore favour analogous ways of organization, this reasonable argument is sufficient to remove the apparent contradiction which seems to result from the distance apart of these creatures in the zoological series.

But a new and greater difficulty seems to arise from the fact that the appendages in the present case are at the free end of the fin. If they came out of the opercular opening, issuing independently close to the origin of the fore-members, as in *Protopterus*, the matter would be comprehensible. But branchial appendages at the very end of the fore-limb itself, that is at first

¹ Knauer, 'Naturgeschichte der Lurche,' Wien, 1878, p. 231 seq.

² *Ibid.* p. 263.

³ *Ibid.* p. 238.

sight rather hard of comprehension, as a very unusual occurrence and a strange combination of such different physiological functions in the same organ.

But the morphological signification of the extremities in the Vertebrates is not yet sufficiently known¹. We have two opposite theories on the subject. The first admits the direct origin and transformation of original branchial arches in the pectoral and pelvic girdle, the fore-limb representing no more than one particularly predominating branchial ray (biserial type of fin; Archipterygium of Gegenbaur). The other theory suggests that the extremities, as well as the paired fins of fishes, are essentially remnants of an originally uninterrupted lateral and dorsal fold on the body of the proto-vertebrate (Wiedersheim). Would it be too audacious to say, that in the case of our captive *Lepidosiren*, which has developed branchial appendages at the end of both its fore-limbs, may be found for the first time a weighty argument in favour of the first of these two theories? If the fore-limb itself is morphologically no other than a ray, specially developed, of the branchial apparatus, may it still appear an impossible eventuality that the fore-limb, under certain conditions, might reassume its old and primitive rôle as part of the supporting-apparatus of the branchial respiration-system?

Finally, there exists still one other possibility, that the so-called fore-limb of *Lepidosiren* is, in fact, not yet a true anterior extremity, but a persistent rudimentary external branchia. I am constrained to express the surprise which not only the peculiar shapes of this formation in all the seven specimens of Amazonian *Lepidosiren*, but also the comparison of them with their respective hind-limbs, have caused me. It is indeed an insignificant, very flat filament, comparable to the barbels of certain South-American members of the family Siluridæ (such as *Ælurichthys gronovii*). On the other hand, the hind-limb is always a very strong, solid, cylindrical, horn-shaped formation, the signification of which as a genuine posterior extremity is, for me, as certain as that of the anterior extremity is uncertain.

If we admit such a possibility, the secondary development of ramifications at the free end of the so-called fore-limb provoked by prolonged and exclusive water-life would become essentially more accessible to our comprehension.²

¹ Wiedersheim, 'Grundriss der vergleichenden Anatomie der Wirbelthiere, June 1898, 4^{te} Auflage, pp. 101, 103.

² [The following remarks were made on this passage of Dr. Goeldi's paper by Mr. G. A. Boulenger, F.Z.S.:—

"With reference to the remarks of Dr. Goeldi on the branchial pectoral limbs of *Lepidosiren*, I would draw attention to a note of mine (see P. Z. S. 1891, p. 147), in which I described a somewhat similar condition in a *Protopterus* living in the Society's Gardens. I have no doubt that the branches noticed by Dr. Goeldi are the result of some injury to the limbs, and represent new growths comparable to the bifid or trifid regenerated tails of *Lizards* and to the polydactyly and even polymely arising from mutilations in *Batrachians*."]]

2. On the Anatomy of the African Jumping-Hare (*Pedetes caffer*) compared with that of the *Dipodidæ*. By F. G. PARSONS, F.R.C.S., F.Z.S., F.L.S., Hunterian Professor at the Royal College of Surgeons and Lecturer on Comparative Anatomy at St. Thomas's Hospital.

[Received October 14, 1898.]

The opportunity of dissecting a somewhat rare Mammal, the African Jumping-Hare (*Pedetes caffer*), was kindly given me by Mr. Oldfield Thomas, of the British Museum. Fortunately the adult specimen was a female, and its uterus contained an embryo which must very nearly have reached its time of birth. Mr. Beddard, the Prosector of this Society, has also kindly placed at my disposal two Jerboas (*Dipus jaculus* and *D. hirtipes*) for comparison.

At the end of the paper will be found a short summary of its chief points of interest.

External Anatomy.

The total length from the snout to the root of the tail is 17 inches, the tail measuring another 18 inches.

The nose is covered by very short fine hair except round the nostrils, where the skin is bare. The upper lip is very long; there is an interval of one inch between the lower part of the nose and the mouth; there is no cleft in the median line, and the space between the nose and the mouth is covered by thick short fur.

The aperture of the mouth is crescentic, the upper lip being curved to expose the incisor teeth, which are white and perfectly smooth. The pointed ears are $3\frac{1}{2}$ inches long, and from the ventral side of the meatus the tragus projects as a conical process $\frac{1}{3}$ of an inch high. The fore limbs are set very far forward, indeed there are only 2 inches between the point of the shoulder and the posterior canthus of the eye; they are very short, the upper arm being especially diminished. The manus has five well-marked digits provided with laterally compressed, pointed, slightly curved claws; the most radial of these, the pollex, is the shortest. In the palm of the hand are two processes; the more radial of these is hemispherical and is situated opposite the base of the outer two digits, its radial side is flattened and is covered with much harder epidermis than the rest, giving an appearance very like that of a small human thumb-nail. On the ulnar side of this is a smaller elevation which is compressed laterally and, unlike the other, covered with hair; it is also much the softer and more freely movable of the two.

There are two pairs of nipples; the more anterior are situated just behind the axilla, 2 inches from the middle line, while the more posterior are $1\frac{1}{2}$ inches behind these and a little nearer the mid-line. There are no inguinal or abdominal nipples.

The hind limbs are very long and the knee and hip-joints are

strongly flexed, while the most comfortable position of the ankle seems to be one of extreme dorsal flexion, so that the dorsal surface of the foot is in contact with the shin as far as the heads of the metatarsal bones. There are four toes in the foot, the hallux being absent and the most fibular toe the smallest; they are provided with strong triangular claws compressed from above downward. The second toe from the tibial side is the largest.

The vagina and rectum open by a common aperture 2 inches below the root of the tail; it is soon divided into a smaller rectal part and a larger vaginal. On each side of the vulval orifice is a crypt about $\frac{1}{8}$ inch deep, and this leads by a wide orifice into a thick-walled, almond-shaped sac $\frac{1}{2}$ inch long. When this sac is opened up, it is seen that at the orifice the mucous membrane has longitudinal rugæ, but that nearer the fundus it is covered with hairs about $\frac{1}{8}$ inch long. The walls are evidently glandular and the cavity contained a quantity of inspissated secretion¹.

On comparing the external anatomy of *Pedetes* with that of *Dipus* one is struck by the general resemblance between the two; there is the same breadth at the back of the head, and want of proportion between the fore and hind limbs; in *Dipus*, however, the upper lip is divided and the white upper incisors are grooved as they are in the embryo of *Pedetes*. There are four pairs of nipples instead of two as in *Pedetes*; the most anterior pair are situated at the root of the neck, and the most posterior almost opposite the vulval orifice.

In the hand the claws closely resemble those of *Pedetes*, but that on the pollex is quite short. As in *Pedetes* there are two prominent projections in the palm; of these the radial is the better developed, but no nail is present.

In the hind foot there are only three toes, and the claws are more laterally compressed than those of *Pedetes*.

The Osseous System.

As the osteology of *Pedetes* is well known and several skeletons of it exist, I shall only make a brief survey of the bones of the specimen in my possession, comparing them with those of the fœtus and of *Dipus jaculus*.

The dorsal surface of the skull is remarkable for the strength and breadth of the nasals; the frontals too are very large, in the median line they are twice as long from before backward as the parietals, while in *Dipus* the parietals and frontals are of the same length. The interparietal only projects for a short distance between the parietals; in the fœtal *Pedetes* the interparietal is much larger than the adjacent supraoccipital. In the lateral view the infraorbital foramen is deeper in *Pedetes* than in *Dipus*, and in the latter animal there is a small separate foramen below through which the infraorbital nerve makes its exit.

¹ The external anatomy of the fœtal specimen will be found with the description of the uterus.

The temporal fossa in both animals is ridiculously small, and is separated from the orbit by a postorbital process, which is much better marked in *Dipus* than in *Pedetes* and is altogether absent in the fœtus. The squamosal is remarkable for a backwardly projecting process which locks it into the periotic bone; this spur is simple in *Pedetes*, but in *Dipus* it is T-shaped, a vertical bar extending at right angles from the hinder end of the primary horizontal one. The periotic has the usual tympanic canal running upward and backward from the laterally compressed tympanic bulla. In *Dipus* the canal is extremely short, and in the fœtal *Pedetes* there is merely a tympanic ring. Above the external auditory meatus in both animals, the supratemporal bulla gives the characteristic swollen appearance to the hind part of the skull. In the fœtus no bullæ are present; the periotic is a mass of cartilage in which the pro-, epi-, and opisthotic ossifications can be seen. The backward projection of the squamosal is, however, quite ossified.

On the ventral surface of the skull the incisors are perfectly white and quite smooth in *Pedetes*; in *Dipus* they are also white, but there is a single longitudinal groove in them. In the fœtal *Pedetes* it is interesting to notice that the incisors, which are just appearing, are also grooved.

The anterior palatine canals are slit-like and not very large in either animal; in *Pedetes* they are situated at the bottom of a rather deep fossa. The bony palate is one of the chief points of difference between the two skulls: in *Pedetes* it reaches as far back as the first molar tooth, in *Dipus* it extends considerably farther back than the last molar. In the fœtus there are rudiments of three teeth on each side, presumably the premolar and first two molars; the most anterior of the three is the one best developed.

On a level with the hinder edge of the internal pterygoid plate there is in *Pedetes* a small median opening in the basioccipital bone; this communicates with the foramina rotunda, but does not open directly into the cranial cavity. More posteriorly in the mid-line of the basioccipital bone is a round aperture, large enough to admit a wax vesta match; in the recent state this was closed by membrane. In the fœtal specimen both these openings are present, but they are bilateral instead of median. In *Dipus* neither is present.

In the mandible the chief difference between the two animals is that in *Pedetes* the symphysis, although not synostosed, is immovable; while in *Dipus* the incisors are capable of separation and approximation as in most myomorphine rodents. In addition to this the angular process is much larger in *Dipus* than in *Pedetes* and is perforated by an oval foramen. The lower incisors too of *Dipus* are much more laterally compressed than they are in *Pedetes*.

The *Atlas* of *Pedetes* is remarkable for having on each side three foramina for the vertebral artery; there are the usual two in the transverse process and dorsal arch, and an additional one formed by a small bridge of bone arching over the groove for the artery midway between the other two. In *Dipus* the one in the transvers

process is missing, but the other two are present. In *Dipus* the 2nd, 3rd, 4th, 5th, and 6th cervical vertebræ have their bodies and arches synostosed. In *Pedetes* they are all free, although the 2nd and 3rd are so very close together that hardly any movement can be allowed between them. In neither animal is there a foramen in the transverse process of the seventh cervical or a ventral tubercle, although that of the sixth is very prominent.

The first thoracic vertebra only has half a facet on the cephalic part of the side of the body, because in both animals the head of the first rib articulates as much with the seventh cervical as with the first thoracic. In *Pedetes* the transverse process of the 10th thoracic vertebra has three processes; the most anterior forms a facet for the articulation of the 10th rib, the middle one is directed outward and corresponds to the tip of the ordinary thoracic transverse process, while the most posterior projects backwards.

In the 11th thoracic vertebra the rib still articulates with the anterior of these tubercles, the middle one is reduced in size and the posterior one is larger. In the 12th vertebra the posterior tubercle has become much larger and has developed into a well-marked anapophysis or accessory process, the middle tubercle has completely disappeared, but the anterior is still present, supporting the 12th rib by a definite articular facet.

In the 1st lumbar vertebra the transverse or, as it is often called, costal process is seen to correspond in shape and position with the anterior tubercle of the transverse process of the posterior thoracic vertebræ, and the anapophysis with the posterior tubercle of the same. The mamillary process or metapophysis first appears on the prezygapophysis of the 10th thoracic vertebra and increases in size vertebra by vertebra into the lumbar region; it is quite plain that it has no homology with any part of the thoracic transverse processes. In the lumbar region the anapophyses are very large and rest against the outer side of the prezygapophyses of the next vertebra behind; the prezygapophysis is therefore locked in between the postzygapophysis and anapophysis of the vertebra in front.

After the seven lumbar vertebræ there are four which are fused to form a sacrum, but only two of these support the ilium, the first forming a much larger part of the articular facet than the second. On the ventral side of the disc between the 4th sacral and 1st caudal vertebræ there is a single bony spur, about 5 mm. in length, attached by fibrous tissue to the disc; it lies a few mm. to the left of the median line. Between the first and second caudal vertebræ a small well-marked chevron-bone is present, and this is succeeded by others, the one between the 3rd and 4th being the most prominent. After this the bones gradually shorten and become more and more elongated antero-posteriorly and compressed laterally. Between the 9th and 10th caudal the true chevron-bone ceases, but a pair of bony tuberosities project from the anterior part of the ventral surface of the 10th vertebra; farther back in

the tail these also gradually die away. There are altogether 31 free caudal vertebræ.

The *Sternum* of *Pedetes* consists of the presternum, four mesosternal sternebræ, and the xiphisternum. The presternum is considerably expanded anteriorly, but narrows suddenly behind the attachment of the first rib. The 2nd, 3rd, 4th, and 5th costal cartilages articulate opposite the joints between sternebræ, the 6th articulates with the posterior part of the last sternebra, the 7th articulates with a cartilaginous mass separating the last sternebra from the xiphisternum, while the 8th is attached to the anterior part of the xiphisternum. In the fœtal specimen centres are present for the presternum and first two sternebræ.

The sternum of *Dipus* is very like that of *Pedetes* in the number of elements present; the chief points of difference are that the 8th rib does not reach it and that the first rib is attached nearer the front of the presternum.

The *Clavicle* both of *Pedetes* and *Dipus* is well marked and has the initial *f* curvature as in man. In the fœtal *Pedetes* the shaft was entirely ossified, but the two extremities were cartilaginous.

The *Scapula* has much more the human shape in *Pedetes* than it has in *Dipus*: this is due to the fact that the vertebral border is much longer in comparison in the former animal than in the latter; there is a very faint indication of a metacromion process in both animals. In the fœtus the ala and spine alone were ossified.

The *Humerus* in *Pedetes* is half the length of the femur, there is a fairly prominent pectoral ridge about the middle of the bone, and the inner condyle is very prominent and curved upward into a hook-like process, but there is no bony supracondylar foramen. The external supracondylar ridge is well marked. In the fœtus the shaft alone is ossified; it is interesting to notice that in the cartilaginous lower end of the bone there is a supracondylar foramen.

In *Dipus* the humerus is considerably less than half the length of the femur; in appearance it closely resembles that of *Pedetes*, there is the same recurved internal condyle and prominent external supracondylar ridge, but the pectoral ridge is more strongly marked.

The *Radius* and *Ulna* in *Pedetes* are very strong and are shorter in proportion than those of *Dipus*, which, besides being longer, are much more delicate; this contrast is doubtless due to the great amount of digging which *Pedetes* has to perform.

The *Carpus* of *Pedetes* consists of, in the proximal row, scapho-lunar, cuneiform, and pisiform; in the distal row, trapezium, trapezoid, os magnum, and unciform. In the interval between the scapho-lunar, trapezoid, and os magnum there is a small wedge-shaped centrale, which is only visible on the dorsal side. Articulating with the radial side of the scapho-lunar is the radial ossicle or præpollex: this structure agrees very closely with that figured

and described by Bardeleben¹: it consists of two joints, of which the proximal is a rod 14 mm. in length, thickened at either end and stretching inwards across the palm; the distal joint is 7 mm. long, flattened from the palmar to the dorsal surface, and broader than the proximal; its long axis is directed outward, so that with the proximal joint it forms an acute angle (see fig. 2, p. 867). The metacarpal bone of the pollex is very short; it is parallel and in the same plane as the other four metacarpals and is not at all opposable (see fig. 1).

Fig. 1.

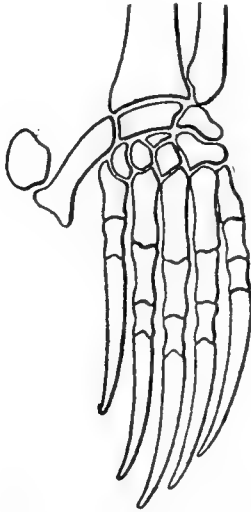

Dorsal view of carpus of *Pedetes caffer*, with radial ossicle flattened out

In the foetal specimen no centres of ossification were present in the carpus; in the metacarpus centres were present for the shafts of the index, medius, and annularis, but not for the pollex or minimus. The præpollex or radial ossicle, as perhaps it will be wiser to term it while its real nature is *sub judice*, is a cartilaginous bar corresponding in shape with the adult structure, but no joint between the two segments could be made out; there were no ossific centres. It will thus be seen that the evidence which this foetal specimen has to give on the radial ossicle is chiefly negative: the structure is apparently a cartilaginous constituent of the carpus from an early period, but how and when it ossifies remains to be seen. It is interesting to notice that the three metacarpals which are most permanent in the mammalian class are the ones which, in this animal, ossify first. If this rule holds good, it could not be expected that the radial ossicle, if it be a præpollex, would ossify until after the minimus and pollex have done so. In *Dipus* there is a single bony bar stretching across the palm and articulating with the radial side of the scapho-lunar; it has the palmaris longus inserted into its free extremity

¹ P. Z. S. 1889, p. 260.

and evidently corresponds to the proximal joint of the same structure in *Pedetes*. No signs of a distal joint are present.

It is worthy of remark that the long axis of the distal joint of the radial ossicle of *Pedetes* is placed at such an angle with that of the proximal that its termination is situated near the root of the nail, while its proximal end is opposite the free edge of the nail. I do not, however, think that this change in the relative position of the parts is of any great importance.

The *Os Innominatum* has the surface for the iliacus directed ventro-laterally, as in the Hares. The ischial tuberosity is very prominent, and the obturator foramen large and pear-shaped. In the foetal bone only the three primary centres are present.

The *Femur* is chiefly remarkable for the large size of the laterally compressed great trochanter, at the base of which a rudimentary third trochanter exists. There are two fabellæ, of which the outer is the larger. The femur of *Dipus* is practically identical, except that the articular surface of the head is continued outward for a considerable distance on to the upper surface of the neck.

The *Tibia* is considerably longer than the femur, the cnemial crest being specially prominent.

The *Fibula* is transitional between the hystricomorphine type, in which it is a distinct bone, and the myomorphine, in which it is fused with the tibia in its lower part. In *Pedetes* the fibula is quite free in its upper half, and from the front of the head a process projects forward and inward; in its lower half the bone is closely bound to the tibia and becomes so attenuated as to be barely visible; it is, however, at no time completely merged with the tibia. The external malleolus is fairly well marked, and considerable movement is allowed between it and the tibia. In *Dipus* the fibula becomes completely incorporated with the tibia in its lower half, as it is in mouse-like rodents generally, and no movement is possible between the external malleolus and the tibia. In the foetal specimen of *Pedetes* only the centres for the shafts of these long bones were present.

The *Tarsus* consists as usual of astragalus, calcaneum, navicular, 3 cuneiforms, and cuboid. The navicular is remarkable for having a process on the plantar surface prolonged from before backward and laterally compressed; it projects anteriorly under the external cuneiform and almost touches the base of the middle (3rd) metatarsal; between its anterior projection and the external cuneiform is a tunnel for the peroneus longus tendon. The internal cuneiform is prolonged forward on the inner side of the base of the second metatarsal, into this projection the tendon of the peroneus longus is inserted; hence there is little doubt that it represents the aborted first metatarsal. The internal cuneiform is also prolonged backward along the inner side of the navicular until it just reaches and articulates with the head of the astragalus. On the inner side of the internal cuneiform is a thin plate of bone with its long axis at right angles to that of the foot; its upper extremity articulates with the inner side of the navicular, while its lower

extremity receives the insertion of the tendon of the flexor tibialis. From its position I think that it may correspond with the radial ossicle in the manus, though it is connected with the distal row of tarsals instead of the proximal. A ligament runs forward from the anterior part of its lower extremity and connects it with the dorsal extensor tendon. In *Dipus*, as is well known, the three middle metatarsals are fused, but on the inner and outer side are rudiments of the first and fifth metatarsals, the former being continuous with the internal cuneiform. In the foetal *Pedetes* there are centres for the calcaneum and for the shafts of the four metatarsals and their phalanges.

The Muscular System.

In former volumes of the Proceedings of this Society¹ I have described the muscles of a considerable number of Rodents. I shall therefore content myself with noticing the chief points in which *Pedetes* agrees with or differs from the typical arrangement.

The *Temporal* is very small and does not meet its fellow in the mid line of the skull.

The *Masseter* has the typical hystricomorphine arrangement; the anterior deep part is very large as in all the Hystricomorpha and Dipodidæ.

The *Facial Muscles* consist of orbicularis palpebrarum, orbicularis oris, levator labii superioris, retractor and depressor naris, depressor anguli oris: there is also a muscle which rises from the malar bone beneath the orbit and deep to the orbicularis palpebrarum; it passes round the chin like a chin-strap, and is inserted into the skin of that region; its fibres are parallel with and in the same plane as those of the sphincter colli, and it is the only representative of the zygomaticus to be found.

The *Depressor Mandibulæ* (Digastric) has the typical sciuromorphic and myomorphic arrangement (figured on p. 255, P. Z. S. 1894), and in this agrees with the Dipodidæ.

The *Transversus Mandibulæ* is absent, but is present in the Dipodidæ.

The *Sterno-mastoid* rises from the presternum and is inserted by tendon into the paroccipital process.

The *Cleido-mastoid* rises from the inner half of the clavicle and is inserted by flesh into the paroccipital process and occipital crest. As in all Rodents the XIth nerve passes deep to both muscles.

The *Sterno-hyoid* and *Sterno-thyroid* are distinct and have the usual human attachments. No tendinous intersection was seen.

The *Omo-hyoid* was absent. It is always present in the Sciuromorpha, Myomorpha, and Dipodidæ.

The *Omo-trachelian* (Levator claviculæ) rises from the anterior arch of the atlas and is inserted into the metacromion deep to the trapezius.

¹ P. Z. S. 1894 and 1896.

Scalene Muscles.—No scalene passes ventral to the subclavian artery and brachial plexus; there is therefore no scalenus ventralis corresponding to the scalenus anticus of human anatomy. In many hystricomorphine and some myomorphine rodents this muscle is present and rises from the basioccipital; it does so in the Dipodidæ, and its absence in *Pedetes* is worthy of notice. The scalenus longus rises from the 2nd, 3rd, and 4th cervical transverse processes and is inserted into the second rib only instead of going to the anterior 4 or 5 ribs. The scalenus brevis is deep to the last: it rises from the 2nd, 3rd, 4th, and 5th cervical transverse processes and is inserted into the first rib.

The *Pectoral muscles* correspond very closely with the description given on p. 259, P. Z. S. 1894. The pectoralis minor (δ) is inserted into the upper part of the pectoral ridge instead of going to the coracoid and shoulder-joint.

The *Subclavius* passes from the junction of the 1st rib with the sternum to the outer half of the clavicle.

The *Scapulo-clavicularis* is absent. This I regard as a most important point, as this muscle was found in all the hystricomorphine rodents examined, but was absent in the Dipodidæ.

The *Deltoid* has the usual three parts, with their characteristic rodent insertion into the humerus. They are all supplied by the circumflex nerve.

The *Teres major* is wrapped round at its insertion by the tendon of the latissimus dorsi as in the Dipodidæ.

The *Flexor longus cubiti* (Biceps) has two heads, in the Dipodidæ there is usually only one. The insertion is into the radius.

The *Coraco-brachialis* rises from the coracoid process and is inserted into the humerus from the middle to the internal condyle, so that apparently the medius and longus are present. In the Dipodidæ the brevis may or may not be present.

The *Flexor Brevis Cubiti* (Brachialis anticus) has the usual external and internal heads, though they are closely fused. The insertion is entirely into the ulna. No branch is received from the musculo-spiral nerve, but there are two from the musculo-cutaneous.

The *Extensor Longus Cubiti* (Triceps) and *Anconeus* show nothing of special interest.

The *Epitrochleo-anconeus* is present as usual.

The *Pronator Radii Teres* passes from the supracondylar arch to the middle of the radius.

The *Flexor Carpi Radialis* has the usual attachments, its tendon passes deep to the base of the radial ossicle or prepollex.

The *Palmaris Longus* rises from the internal condyle and from the surface of the flexor sublimis digitorum: in the lower part of the forearm its tendon divides; the inner and broader portion is inserted into the radial ossicle at its most internal part as well as into the ulnar ossicle; the outer and narrower part is attached to the middle of the internal border of the radial ossicle (see fig. 2). In connection with this it is interesting to compare the figure of

the fore foot of *Cœlogenys paca* (P. Z. S. 1894, p. 271): it will there be seen that the palmaris longus is inserted into the distal joint of the radial ossicle or prepollex, which in this animal is cartilaginous, as well as into the ulnar cartilage, which presumably represents the post-minimus, and into another cartilage which is intermediate between the two.

Fig. 2.

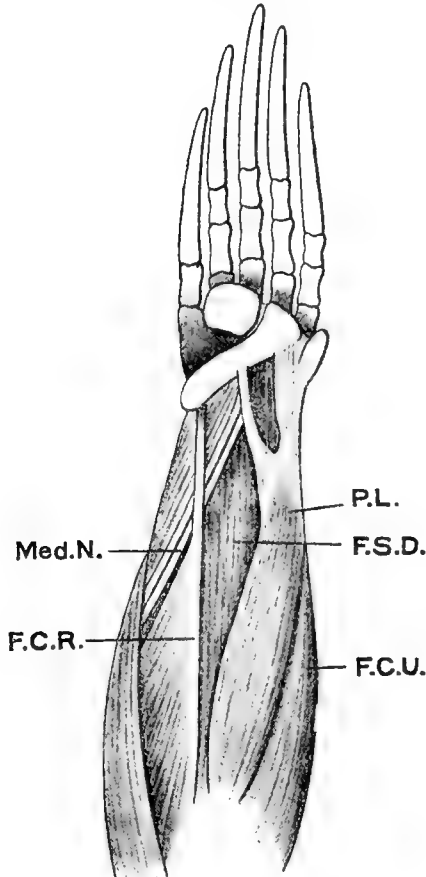
Forearm of *Pedetes*.

Med.N. Median nerve.

F.C.R. Flexor carpi radialis.

P.L. Palmaris longus.

F.S.D. Flexor sublimis digitorum.

F.C.U. Flexor carpi ulnaris.

The *Flexor Sublimis Digitorum* runs from the internal condyle to the four inner digits, the tendon to the minimus being very small. It is entirely supplied by the ulnar nerve.

The *Flexor Carpi Ulnaris* is normal and passes to the pisiform bone.

The *Flexor Profundus Digitorum* arises by two heads from the internal condyle of the humerus as well as from the flexor surfaces of the radius and ulna. As the two condylar heads join the radial side of the rest of the muscle about the wrist, they probably

correspond to the condylo-radial and condylo-central elements described by Windle¹. In the hand a tendon is given off to each of the five digits. The nerve-supply of the muscle is derived entirely from the median.

The *Lumbricales* are four, and are arranged as in man.

The *Pronator Quadratus* is attached to the lower third of the radius and ulna.

The *Supinator Longus* is absent. It is present in the Dipodidæ, but is usually absent in the Hystricomorpha.

The *Extensores Carpi Radiales Longior and Brevior* are normal, the latter being the larger.

The *Extensor Communis Digitorum* goes to the four ulnar digits.

The *Extensor Minimi Digiti* goes to the 5th digit only.

The *Extensor Carpi Ulnaris* and *Extensor Ossis Metacarpi Pollicis* are both normal.

The *Extensores Primi et Secundi Internodii Pollicis* are absent.

The *Extensor Indicis* is small and only goes to the index.

The *Supinator Brevis* is large and is inserted into the upper two-thirds of the radius. A large sesamoid bone which rests against the head of the radius is developed in the tendon.

Fig. 3.

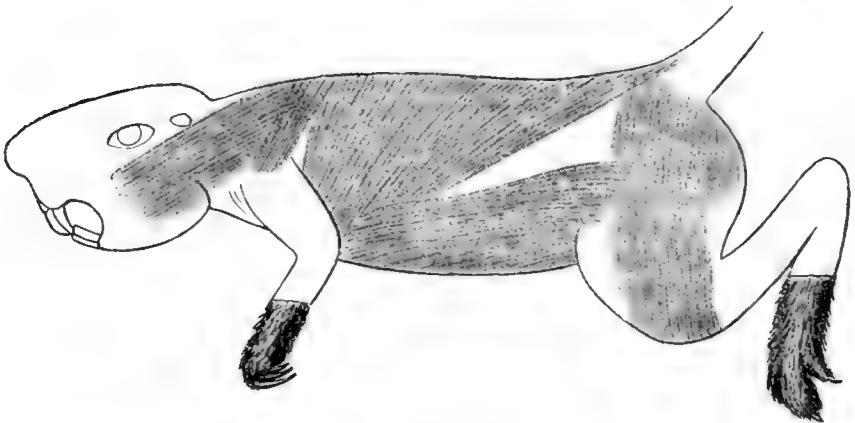

The panniculus of *Pedetes*

Hand-Muscles.—From the ulnar and distal sides of the radial ossicle muscular fibres arise: some run inwards to the ulnar ossicle, forming a palmaris brevis; some run distalward to the skin of the palm, while others again pass to the pollex, forming an indistinct abductor and flexor brevis pollicis. The hypothenar muscles are very feebly marked and indistinct, but an abductor minimi digiti can be made out.

The second layer of hand-muscles consists, as is so often the case, of adductores pollicis, indicis, et minimi digiti.

In the third layer there are two-headed flexores breves to each finger.

Among the *Trunk-Muscles* the *Panniculus carnosus* is remarkable

¹ Journ. of Anat. vol. xxiv. p. 72.

for its great development over the gluteal region and outer part of the thigh (see fig. 3).

The platysma, dorso-humeralis, and abdomino-humeralis are also well marked. The sphincter colli is feeble and does not extend back superficial to the pectoralis at all.

The *Latissimus Dorsi* comes from the last three ribs and lumbar fascia; it hardly reaches the thoracic spines. Its tendon wraps round and is inserted ventral to that of the *teres major*.

The *Trapezius* in the Dipodidæ is divided into an anterior and posterior part, a distinct gap intervening between them. In *Pedetes* the muscle is quite continuous as in man.

The *Rhomboides Capitis, Colli et Thoracis* form one continuous sheet as in most hystricomorphine rodents.

The *Levator Anguli Scapulae* and *Serratus Magnus* rise from all the cervical transverse processes and from the first rib, then there is a gap, after which the origin is continued from the 3rd to the 7th ribs. The first part is inserted into the whole of the vertebral border of the scapula, the second part only into the angle.

The *Serratus Dorsalis* (*S. posticus*) in the Dipodidæ is hardly developed at all. In *Pedetes* both the thoracic and lumbar parts are well marked, the former being attached from the 4th to the 9th ribs, the latter from the 8th to the 12th.

The *Transversalis Colli* is large and attached from the 2nd to the 7th cervical vertebræ.

The *Transversalis Capitis* or *Trachelo-mastoid* is absent.

The *Splenius Capitis* was present as usual; a small *Splenius Colli* was inserted into the transverse process of the atlas only.

The *Complexus* could not be separated into two parts. A linear V-shaped intersection occurred in it, the apex of the V being downwards.

The *External Oblique* rises from the third to the last rib.

The *Internal Oblique* and *Transversalis* were easily separable in the lateral part of the abdominal wall.

The *Rectus ventralis* (Abdominis) rises from the crest of the pubes, but does not decussate with its fellow of the opposite side; it is continued forward to the first rib, and there are five tendinous intersections in its course.

The *Supracostalis* is well marked; it rises from the sternum, opposite the attachment of the first two rib-cartilages, by a membranous origin and is inserted into the first rib opposite the insertion of the scalenus. It is, of course, superficial to the *rectus ventralis* and deep to the pectorals.

The *Ilio-tibialis* (*Sartorius*) runs from Poupart's ligament to near the patella, where it is lost in the fascia; it is supplied by the anterior crural nerve.

The *Tensor Fasciæ Femoris* continues the plane of the last muscle outward; it reaches the lower third of the thigh.

The *Ectogluteus* continues the plane of the last and has the typical mammalian characteristics; it is inserted just below the great trochanter. Externally it is continuous with the *Caudo-*

femoralis or *Agitator caudæ*, a large muscle inserted into the lower end of the femur by tendon and reminding one of the same muscle in the Guinea-pig figured on p. 737 of the 'Journal of Anatomy,' vol. xxxii.

The *Meso-gluteus* rises from the anterior part of the gluteal surface of the ilium and from the margin of the sacrum dorsal to the great sciatic notch. It is closely connected with the *Pyri-formis*, and is inserted into the outer side of the great trochanter.

Fig. 4.

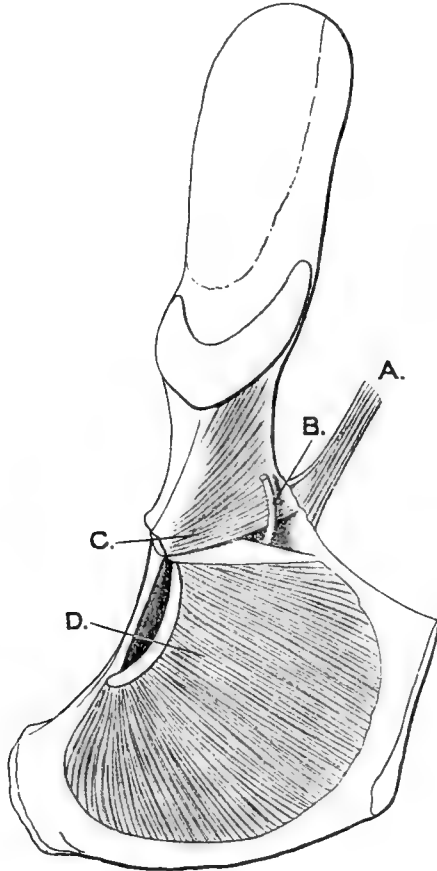
Inner view of wall of pelvis of *Pedetes*.

C. & D. Upper and lower portions of the obturator internus.		B. Obturator nerve. A. Psoas parvus.
--	--	---

The *Ento-gluteus* rises from the ilium dorsal to the last and is inserted into the anterior surface of the great trochanter.

The *Gluteus ventralis* (*Scansorius*) rises behind and ventral to the last and is inserted into a tubercle below the outer side of the great trochanter.

The *Obturator Externus*, *Obturator Internus*, and *Gemelli* are all inserted into the digital fossa. The obturator internus is divided

into two by the obturator nerve (see fig. 4). The gemelli are fused and form one layer deep to the obturator internus tendon.

The *Quadratus Femoris* is triangular, with its apex towards the great trochanter.

The *Flexor Cruris Lateralis (Biceps)* has only one head, which comes from the tuber ischii. It is inserted into the patella and upper half of the leg. There is no *Tenuissimus* and no continuation of its lower fibres down with the tendo Achillis.

The *Semitendinosus* rises by two heads from the tuber ischii and from the anterior caudal vertebræ, but there is no tendinous intersection where these join. It is inserted deep to the gracilis, the lower fibres forming a fascia which helps to ensheath the tendo Achillis and to blend with it.

The *Semimembranosus* rises only from the tuber ischii. It is inserted into the lower end of the femur just above the internal condyle, into the postero-internal part of the capsule of the knee-joint, and into the internal tuberosity of the tibia by one continuous insertion. There is no presemimembranosus distinct from this, and I regard *Pedetes* as an animal in which the semimembranosus and presemimembranosus are inseparable from origin to insertion.

The *Adductor Cruris (Gracilis)* is single and is inserted into the cnemial crest and upper third of the anterior border of the tibia. It does not reach so high as the patella. In the greater number of hystricomorphine and myomorphine rodents there are two adductores cruris.

The *Pectineus* is a small muscle rising from the ilio-pectineal line just internal to the insertion of the psoas parvus and being inserted into the second quarter of the femur. It is supplied entirely by the obturator nerve.

The *Adductor anticus (Adductor longus)* is that part of the adductor mass which lies ventral to the obturator nerve and is indicated by the point of emergence of the branch to the adductor cruris. It arises from the inner part of the ilio-pectineal line and is inserted into the middle two-fourths of the femur.

The rest of the *Adductor mass (Adductores medius et posticus)* rises from both rami of the pubes, from the symphysis, and from the ramus and tuberosity of the ischium. It is inserted into the middle two-fourths of the femur.

The *Quadriceps Extensor Cruris* has the usual four heads. The *Superficialis quadricipitis (Rectus Femoris)* has only one head, which probably corresponds to both the straight and reflected heads of human anatomy.

The *Lateralis quadricipitis (Vastus externus)* is much larger than the *mesialis (V. internus)*. The *Profundus quadricipitis (Crureus)* rises from the whole length of the shaft of the femur.

The *Tibialis Anticus* has no femoral origin. It rises from the upper third of the tibia and is inserted into the rudimentary first metatarsal.

The *Extensor Longus Digitorum* rises as usual from the external condyle of the femur: it divides into a superficial and deep layer;

the former runs to the index and medius, the latter to all four digits.

There is no trace of an *Extensor Proprius Hallucis*.

The four *Peroneal Muscles* (*longus, brevis, quarti digiti, and quinti digiti*) have the attachments usually found in hystricomorphine rodents.

The outer head of the *Gastrocnemius* rises from the external condyle and outer side of the patella; a large fabella is developed in it. The inner head only comes from the condyle and has a smaller fabella.

The *Plantaris* rises from the external fabella; it is large and fleshy in the calf; its tendon with that of the gastrocnemius forms the usual rope-like twisting described in the 'Journal of Anatomy' (vol. xxviii. p. 414). In the sole there is no muscular belly representing the flexor brevis digitorum, but tendons pass to form flexores perforati to all four digits, though the outermost is very small.

The *Soleus* rises from the outer side of the head of the fibula; it joins the tendo Achillis just above the ankle.

The *Popliteus* is normal.

The *Flexor Tibialis* (*Flexor longus digitorum*) rises from the second quarter of the posterior surface of the tibia, below the popliteus. It is inserted into the tibial ossicle (see fig. 7, p. 877).

The *Flexor Fibularis* (*Flexor longus hallucis*) rises from the upper half of the back of the tibia and fibula and sends tendons (flexores perforantes) to all four toes.

It will thus be seen that in *Pedetes* the flexor tibialis fails to join the flexor fibularis in the sole. This is a marked contrast to the arrangement in the Dipodidæ and also to that of most of the Hystricomorpha.

The *Tibialis Posticus* and *Accessorius* are absent.

The two middle *Lumbricales* are present.

Of the deep muscles of the foot the first layer consists of an *adductor indicis* and of an *adductor minimi digiti*. The second layer contains four double-headed *flexores breves*. The third layer is represented by one dorsal interosseous muscle between the index and medius; it is inserted into the dorsal expansion of the medius.

In contrasting the myology of *Pedetes* with my former work on the muscles of other Rodents, it is evident that this animal, like the Dipodidæ, occupies a position between the Hystricomorpha and Myomorpha. The most important Hystricomorphine characteristics are:—

1. The large anterior deep part of the masseter passing through the infraorbital foramen: this is always found in the Hystricomorpha and never, so far as I know, in the Myomorpha except in a very rudimentary condition.
2. The absence of the transversus mandibulæ, which is always present in the Myomorpha.
3. The absence of the omo-hyoid. It is true that this muscle is

not always absent in the Hystricomorpha, but it is always present in the Myomorpha.

4. The presence of a splenius colli. This is not a very important point, but I have never yet found the muscle among the Myomorpha.

The most important Myomorphine characteristics are :—

1. The arrangement of the depressor mandibulæ (digastric). This has the tendinous arcade and fused anterior bellies so characteristic of myomorphine and sciuromorphic rodents.
2. The absence of a scalenus ventralis. This muscle is not always present in the Hystricomorpha, but it is always absent in the Myomorpha.
3. The absence of a claviculo-scapularis, a muscle which was always found in the Hystricomorpha but never in the Myomorpha.
4. The flexor tibialis does not unite with the flexor fibularis in the sole as it usually does in the Hystricomorpha. Dobson made a great point of the value of these tendons for classificatory purposes, but I have met with evidence to show that it is not altogether reliable.
5. The biceps cubiti (flexor longus cubiti) has two heads : this arrangement is almost invariable among the Myomorpha, but it also sometimes occurs in the Hystricomorpha.

With regard to the relationship of *Pedetes* with the Dipodidæ, the following resemblances are important and suggestive :—

1. There is a tendinous arcade in the digastric and the anterior bellies are in contact.
2. There is no claviculo-scapularis.
3. The origin of the omo-trachelian (levator claviculæ) is from the atlas.
4. The rectus ventralis does not decussate with its fellow in front of the pubic arch.

The following, on the other hand, are points in which *Pedetes* differs from the Dipodidæ :—

1. The scalenus ventralis (anticus) does not rise from the basi-occipital bone.
2. There are two heads to the biceps cubiti (flexor longus cubiti).
3. There is no transversus mandibulæ.
4. There is no omo-hyoid.
5. The splenius colli is present.
6. The flexor tibialis does not join the flexor fibularis in the sole.

I am of opinion that a careful comparison of the muscles of *Pedetes* with those of other Rodents shows that it is allied

to the Dipodidæ, but that it occupies a position between them and the Hystricomorphine Rodents; and, if it is desirable for practical purposes to arbitrarily draw a sharp line between the Hystricomorpha and Myomorpha, *Pedetes* would fall on the hystricomorphine side and the Dipodidæ on the myomorpha.¹

Ligamentous System.

The *Temporo-maxillary joint* has a well-marked lax meniscus; when the condyle glides forward and backward the meniscus accompanies it, but the hinge-like movements of opening and closing the mouth take place between the condyle and the meniscus.

The *Sterno-clavicular joint* is formed by the inner end of the clavicle, which is bevelled at the expense of its ventral surface so as to slide dorsal to the manubrium sterni. This inner part of the clavicle is cartilaginous and is fastened to the sternum by fibrous tissue.

Acromio-clavicular joint.—The acromion is united to the clavicle by fibro-cartilage and there is no joint cavity here.

The *Coraco-clavicular ligament* is well marked and runs from the dorsal border of the clavicle to the coracoid.

The *Shoulder-joint* has a lax capsule without any openings, except that for the biceps tendon, or any appreciable thickenings. Both coraco- and gleno-humeral ligaments were looked for, but no trace of them was seen.

The *Elbow* is chiefly remarkable for a well-marked crescentic sesamoid bone in the orbicular ligament; it is attached to the external condyle by the external lateral ligament and gives origin to the supinator brevis; it articulates with the radius and the humerus, and between it and the olecranon there is a pad of fat. Pronation through $\frac{1}{3}$ of a circle is allowed at this joint when the muscles are removed.

The interosseous membrane between the radius and ulna is very strong; above most of the fibres run from the ulna downward and outward to the radius, below they mostly have the opposite direction. There is no synovial cavity between the lower end of the ulna and radius, but the triangular fibro-cartilage is continuous with the interosseous membrane.

Wrist-joint.—The styloid process of the ulna is large and rounded, and fits into a concavity formed by the cuneiform and pisiform bones. The anterior ligament of the wrist contains ulno-carpal and radio-carpal bands, which both run to the great scapho-lunar bone. The prepollex articulates with the radial extremity of the scapho-lunar (see fig. 1, p. 863), and there is a well-marked

¹ Since writing the above I have re-read a paper by Mr. Oldfield Thomas on the "Genera of Rodents." P. Z. S. 1896, p. 1012, and am pleased to find that his views on the position of *Pedetes*, founded on a study of the skull and teeth, agree exactly with my own. I hope soon to be able to compare the muscles of *Anomalurus* with those of *Pedetes*.

synovial cavity which communicates with the main cavity of the carpus. The distal segment of the radial ossicle is connected with the proximal by means of ligaments, but there is, as far as I can make out after careful examination, no synovial cavity.

Hip-joint.—The capsule is not specially thickened at any one place; it is attached all round the acetabulum and to the transverse ligament ventro-caudally; externally it thins suddenly before its attachment to the junction of the neck and shaft, so that the margin of the thick part forms a sphincter round the neck of the femur. The cotyloid ligament is much broader in proportion than in man and keeps the head of the femur in position, so that a good deal of force is required to release it. Over the cotyloid notch, where it is just as broad as elsewhere, it forms the transverse ligament. The ligamentum teres consists of a narrow ribbon-like band of fibrous tissue contained in a sheath of synovial membrane. The fibrous tissue is continued through the cotyloid notch and under the transverse ligament to the dorsal part of the capsule; it checks no movement of which the joint is capable, but, in extreme flexion, tenses some of the dorsal part of the capsule. The Haversian pad of fat is present and well marked.

Fig. 5.

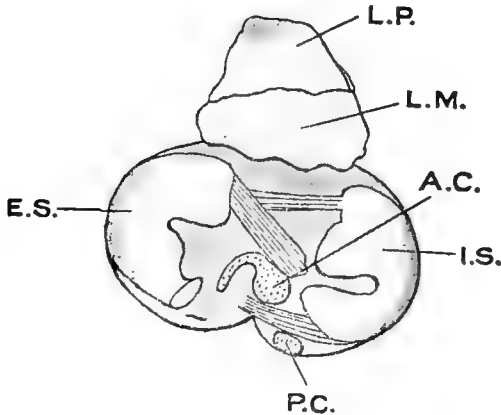
Knee-joint of *Pedetes* with the femur removed.

L.P. Ligamentum patella.

L.M. Ligamentum mucosum.

E.S. & I.S. External and internal semilunar cartilages.

A.C. & P.C. Anterior and posterior crucial ligaments.

The Knee-joint.—On opening the joint from the front the synovial membrane is seen to be continued up for about $\frac{1}{4}$ inch above the upper limit of the trochlear surface. The origins of the extensor longus digitorum and popliteus are both within the synovial cavity. The external lateral ligament runs downward and very much backward to the head of the fibula. The internal lateral ligament is not prolonged so far down the tibia as it is in many mammals; it passes from the internal condyle downward and forward, to the head of the tibia $\frac{1}{4}$ in. below the level of the joint.

The posterior ligament consists only of vertical fibres which are pierced by the large azygos artery.

Laterally, behind the condyle on each side, the joint cavity communicates with a bursa under the respective heads of the gastrocnemius, while in each head of the gastrocnemius there is a fabella. The two crucial ligaments have the human attachments, but they are not connected together at all. The synovial membrane of the ligamentum mucosum is continued back to the crucial ligaments, so that it is impossible to pass a probe between the ligamentum mucosum and the anterior crucial ligament as in man. The semilunar cartilages are remarkable for having their anterior parts ossified; this is interesting when it is compared with the condition of the orbicular ligament in the elbow, though, as has already been pointed out, the animal was a fully adult, if

Fig. 6.

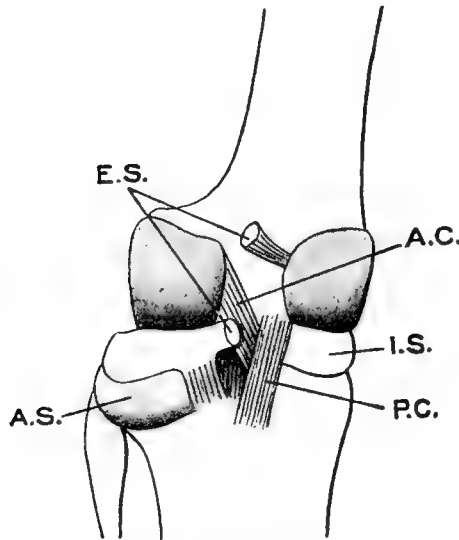

Knee-joint of *Pedetes* from behind.

A.C. & P.C. Anterior and posterior crucial ligaments.

E.S. & I.S. External and internal semilunar cartilages.

A.S. Articular surface over which popliteus plays.

not an aged specimen. The posterior attachment of the external cartilage runs upward and inward, to be attached to the back of the internal condyle; it lies in a plane posterior to that of the posterior crucial ligament and evidently corresponds to the oblique ligament of Humphry of human anatomy (see fig. 6). The posterior part of the external coronary ligament is the only part present, but the internal semilunar cartilage has more or less of a coronary ligament all round. The two cartilages are connected to the lateral ligaments by loose connective tissue, so that they can move independently of these. In extension of the joint there is a considerable portion of the articular surface of the external tuberosity of the tibia behind

the external semilunar cartilage; over this the popliteus tendon glides (see fig. 6, A.S.).

The Ankle-joint.—A strong ligament runs from the front of the lower extremity of the tibia, just at the upper attachment of the anterior ligament of the ankle, forward to join the expansion of the extensor longus digitorum on the inner side of the medius digit and opposite the metatarso-phalangeal joint. The anterior ligament of the ankle is very feeble and has a layer of fat between it and the synovial membrane. The posterior ligament is practically absent. The external lateral ligament consists of three bands: the most superficial runs from the tibia at the posterior margin for the groove of the peroneals to the upper margin of the outer surface of the calcaneum just below the tip of the external malleolus. A second ligament runs downward and backward, from the anterior border and tip of the external malleolus, crossing deeply to the last ligament and being attached to the calcaneum just behind it. A third ligament runs from the back of the external malleolus to the outer side of the

Fig. 7.

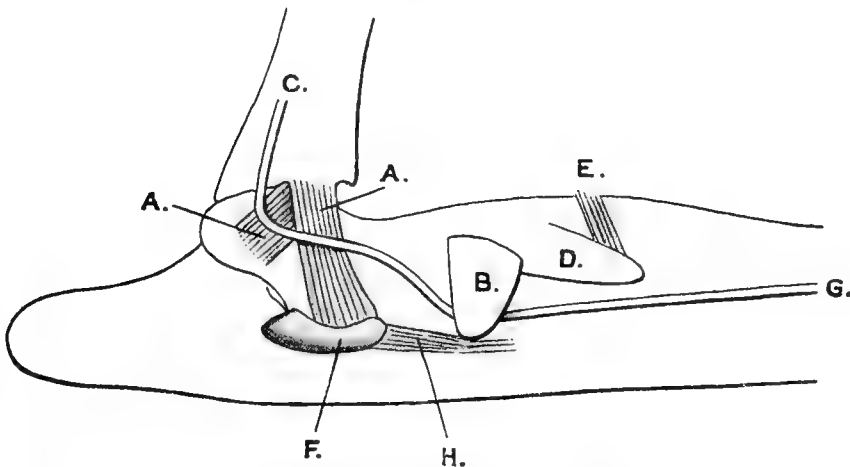

Inner view of ankle and foot of *Pedetes*.

- | | |
|---|---|
| <p>A. Internal lateral ligament.
 B. Tibial ossicle.
 C. Flexor tibialis tendon.
 D. Rudimentary 1st metatarsal.
 E. Tibialis anticus tendon.</p> | <p>F. Sustentaculum tali.
 G. Ligament running forward to dorsum of toe.
 H. Calcaneo-navicular ligament.</p> |
|---|---|

astragalus. It will be noticed that the last-named two bands correspond to the middle and posterior fasciculi of the human external lateral ligament, but that the anterior fasciculus of that ligament is absent. The internal lateral ligament consists of two bands, superficial and deep; the superficial runs downward and forward from the internal malleolus to the sustentaculum tali; the deep band is shorter and runs from the same place downward and backward to the inner side of the astragalus.

Tarsal joints.—The astragalus is bound to the calcaneum by dorsal and interosseous ligaments; they are both very strong, and the latter runs from the plantar surface of the head of the astragalus to the anterior part of the dorsal surface of the calcaneum.

Dorsal ligaments between the other tarsal bones are present but are not worthy of special mention. The calcaneo-navicular ligament is strong and consists of two layers of fibres; the plantar run antero-posteriorly and the dorsal transversely. The long calcaneo-cuboid ligament is well marked and runs forward chiefly into the origins of the deep muscles of the sole; beneath the bases of the 4th and 5th metatarsals there is a sesamoid bone in this ligament. The short calcaneo-cuboid ligament lies deep to the last and is entirely concealed by it; it is well marked and runs from bone to bone.

The *Tarso-metatarsal joints* have dorsal and plantar ligaments.

The *Metatarso-phalangeal joints* have two sesamoid bones developed in the plantar ligament; these bones are firmly connected with the phalanx, but very loosely with the metatarsal bone, so that they can glide over the head of the latter; lateral ligaments connect the metatarsal bone with the phalanx and each of these with the sesamoid bone.

Digestive System.

The Palate.—Just behind the upper incisor teeth is a well-marked fossa $\frac{1}{8}$ inch deep (A, fig. 8, p. 879); behind this are two triangular patches of fur, the apices of which meet in the middle line (C, fig. 8). Behind these, on each side, there is an elongated piriform fossa which projects backward on the outer side of the molar teeth, lying between these and the zygoma (B, fig. 8). The anterior part of this fossa is the broader and is $\frac{1}{8}$ inch deep. Posteriorly it tails off and becomes shallower. The hard palate is raised into nine transverse ridges on each side; the hindermost of these is opposite the premolar tooth. The anterior five of these ridges meet their fellows in the mid line. The posterior four fail to do so. The hinder part of the hard palate is smooth. The soft palate and the pillars of the fauces form a piriform opening of small size, through which the naso-pharynx communicates with the bucco-pharynx.

The *Tongue* is remarkable for the presence of a large number of filiform papillæ on its posterior third; they are long and quite hide the circumvallate papillæ. The foliate papillæ are feebly marked, and consist of fourteen short parallel slits on each side without any definite oval ring enclosing them.

The *Stomach* is almost human in shape, except that the part corresponding to the greater cul-de-sac is ill-developed. The greater curvature measured $6\frac{1}{2}$ inches, the lesser $1\frac{1}{2}$ (see fig. 9).

The *Duodenum* forms, as usual, a large free loop; it is 11 inches long. The rest of the *small intestine* measures 6 feet 5 inches, making a total of 7 feet 4 inches from the pylorus to the ileo-

Fig. 8.

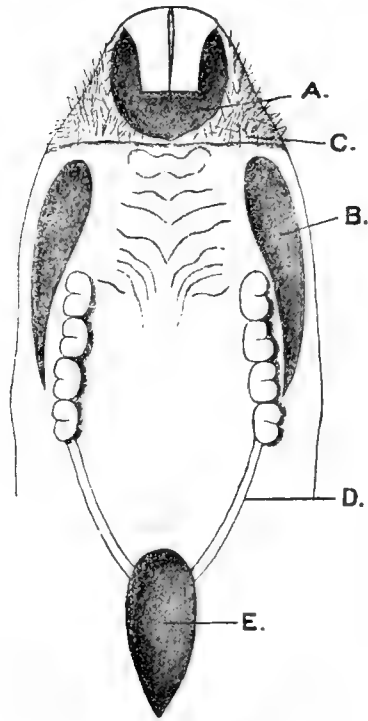

Palate of *Pedetes*.

- | | | |
|------------------|--|--------------------------------|
| A. & B. Fossæ. | | D. Cut edge of soft palate. |
| C. Patch of fur. | | E. Posterior opening of nares. |

Fig. 9.

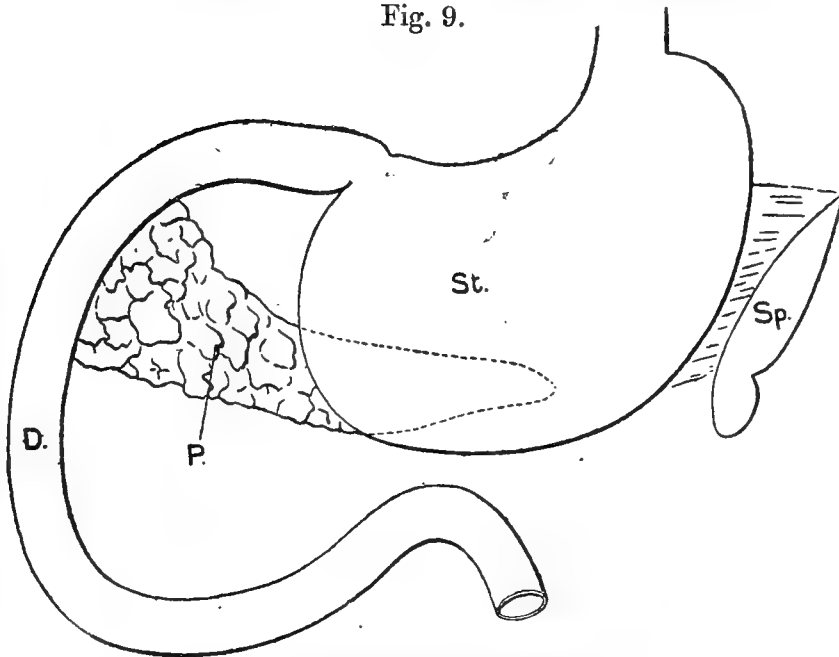

Digestive organs of *Pedetes*.

- | | | |
|--------------|--|--------------|
| D. Duodenum. | | St. Stomach. |
| P. Pancreas. | | Sp. Spleen. |

cæcal valve. The ileum opens into the cæcum on its posterior surface, but there is no *sacculus rotundus* (see fig. 10).

Fig. 10.

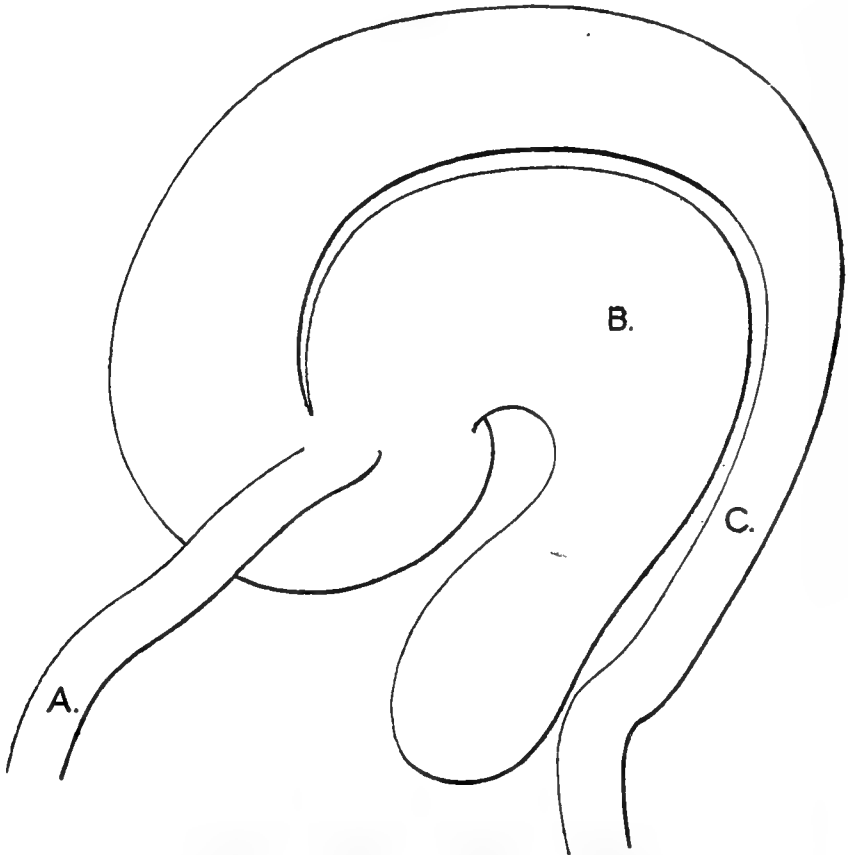

Cæcum of *Pedetes* viewed from behind.

A. Ileum. B. Cæcum. C. Colon.

The *Cæcum* is a thin-walled sac of large calibre, 8 inches in length. It is bent into a horseshoe loop, and round the convexity of the horseshoe the colon lies, the two viscera being bound together by areolar tissue and having no peritoneum between them. The cæcum ends bluntly, and there is no appendix. When the cæcum is opened the ileo-cæcal orifice is seen; this is a transverse slit $\frac{1}{4}$ inch long, capable, when fully distended, of admitting a quill-pen. The valve which guards this opening has, as usual, two lips, cæcal and colic. The cæcal lip is the more prominent, and is prolonged halfway round the gut as a shelf; the colic lip does not extend so far. The mucous membrane of the cæcum has a number of transverse rugæ; these are best marked opposite the posterior part where the vessels enter and the peritoneal attachment is. The *Colon* is at first dilated,

but rapidly narrows, and 7 inches from the valve attains its normal calibre. It measures 3 feet 10 inches from the valve to the anus.

The alimentary canal of the foetus corresponds very accurately with that of its mother; the cæcum has the same arrangement. No Meckel's diverticulum was seen in the ileum.

The *Pancreas* is a fleshy tongue-shaped gland, about 3 inches long, lying in the concavity of the duodenum; its duct enters the latter about 3 inches from the pylorus (see fig. 9).

The *Spleen* is relatively very small; it measures $1\frac{3}{4}$ inches in its long diameter, and is remarkable for having a notch on its posterior border (see fig. 9). In the foetus it was comparatively much longer and was triangular in section; no notches were present.

Fig. 11.

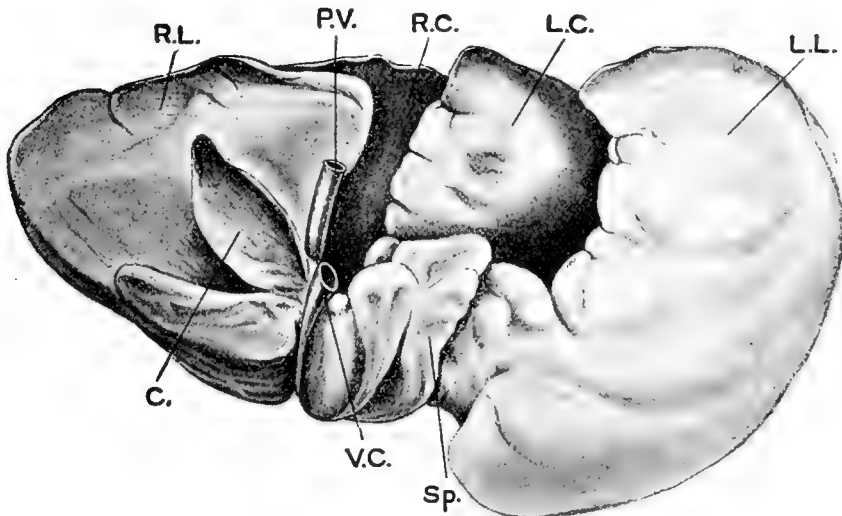
Under surface of liver of *Pedetes*.

R.L. Right lateral lobe.
 R.C. Right central lobe.
 L.C. Left central lobe.
 L.L. Left lateral lobe.

C. Caudate lobe.
 Sp. Spigelian lobe.
 P.V. Portal vein.
 V.C. Vena cava.

The *Liver* contains the six typical lobes—right and left central, right and left lateral, spigelian, and caudate. Of these the left lateral is much the largest, and the caudate has the characteristic leaf-like shape. In the foetus the lobulation is identical, but neither in it nor in the adult specimen is there any gall-bladder.

On comparing the digestive system of *Dipus* with that of *Pedetes*, it was noticed that the depressions behind the incisor and on the outer sides of the molar teeth are wanting, while the ridges on the hard palate extend back as far as the last molar tooth. There are, however, the same two triangular patches of fur, meeting by their apices behind the upper incisors. In the stomach the great cul-de-sac is better developed than it is in

Pedetes. The cæcum is 4 inches long in *Dipus jaculus*; it has a much larger calibre than either intestine, but is not characteristically coiled; it is sacculated, and has a fold of peritoneum, about $\frac{1}{8}$ inch wide, running along one margin and ending in a free border containing vessels. In the liver of *Dipus jaculus* the right central and right lateral lobes apparently were fused into one large one; the caudate lobe was large, and resembled that of the Rabbit in shape and relations. In *Dipus hirtipes* the right lateral lobe was distinct, though small, and was closely pressed against the caudate, so that the two lobes together made a concavity for the anterior part of the right kidney. The gall-bladder was well marked in both species of *Dipus*.

Respiratory System.

The *Larynx* shows little worthy of special mention; the arytenoids, as is usual in Rodents, lie at the sides of the larynx. There are no false vocal cords, but the true ones are well marked. The epiglottis is remarkable for a very prominent cushion. The *Trachea* is $1\frac{1}{2}$ inches long, and has 18 rings before its bifurcation. Opposite the 6th ring, *i. e.* $\frac{1}{2}$ inch from the cricoid, a median septum commences, and after this the trachea is a double-barrelled tube. The septum at first consists merely of mucous membrane, and has a concave free edge towards the larynx; lower down cartilaginous rings are continued into it, and these eventually become double. In the foetal specimen the same septum was noticed; it reached as far forward as the 3rd ring (there were 16 rings altogether). The right lung has four lobes, of which one is the azygos. The left lung has three. There is an eparterial bronchus on the right side.

In the respiratory system *Dipus* has no septum in its trachea; the right lung has four lobes, as in *Pedetes*, but the left only had a single lobe in *Dipus jaculus* and *hirtipes*.

Urino-Genital System.

The *Kidneys* are compact spheroidal bodies and are very nearly on the same level; the right renal artery is, however, rather more anterior (cephalic) than the left. On section one large median papilla is seen opening into the pelvis renalis, and when this is turned aside two smaller ones are found in front and behind it; there is also a small one above and below, making seven in all.

The *Adrenals* are described with the vascular system.

The *Bladder* was contracted in this specimen, it measured $1\frac{1}{2}$ inches in its longest diameter; the ureters open at the junction of the anterior $\frac{2}{3}$ with the posterior $\frac{1}{3}$ of the dorso-lateral aspect.

The *Urethra* is $1\frac{3}{4}$ inches long, and opens into the vagina $\frac{1}{4}$ inch from the vulval orifice.

The *Uterus* is bicornuate, and the foetus was situated in the right cornu, the placenta being attached to the antero-external part, close to the opening of the Fallopian tube. The left cornu was normal and was 1 inch long. The cervix uteri projects into

the vagina for $\frac{1}{2}$ inch, and on the dorsal side of its extremity are two external ora.

The *Vagina* is 3 inches in length, and is marked by prominent longitudinal rugæ.

The *Fallopian Tubes* differ on the two sides, that on the right (the pregnant side) is $1\frac{1}{2}$ inches, while the left only measures $\frac{1}{4}$ inch.

The *Ovaries* are situated in a peritoneal pouch corresponding to the arrangement figured by Robinson¹ in the Porcupine. The right one is $\frac{1}{4}$ inch long, fusiform and smooth; the left one is larger and more spherical.

The *Placenta*, when the membranes were opened, was seen to be a thick disc 2 inches long by $1\frac{1}{2}$ broad; its uterine surface was convex and smooth, its foetal surface concave and lobulated. The umbilical cord was 5 inches long and was attached to the foetal surface on one side of the middle.

The *Mammary Gland* is very large and occupies the whole of the pectoral region as well as a good deal of the lateral wall of the thorax; ventrally it reaches the mid line, dorsally it extends rather beyond a line drawn horizontally backward from the dorsal fold of the axilla. Anteriorly it reaches to within $\frac{1}{2}$ inch from the clavicle, while posteriorly its edge corresponds to the costal margins. As has been already stated, there are two nipples on each side.

The *Fœtus* was 7 inches long from the snout to the root of the tail, the tail itself being another 3 inches. The head was flexed on the ventral surface of the thorax, and the fore limbs tucked in under the chin. All the joints of the hind limb were strongly flexed, the ankles being close together and the feet crossing so that the right was the more superficial. The tail was coiled up on the right of the right thigh and leg. The eyelids were closed, but could be opened by a little traction. The auricles differed in position on the two sides; that on the right was folded back over the neck, reaching as far as the mid-dorsal line, while the left was turned down and partly covered the eye. The skin was devoid of hair, but the vibrissæ on the side of the snout were numerous and about $\frac{1}{4}$ inch long; there were also five or six shorter bristles above each eye, and three on each side growing from a small flat papilla on the side of the face, dorsad and caudad of the eye. The claws were indicated, but were not yet hardened. The fœtus was of the male sex, and the genital aperture was situated on the summit of a well-marked eminence; at first sight there appeared to be two genital openings, but the more caudal was a blind pouch. The anus was a transverse, slightly crescentic slit.

When the skin was removed the eminence was seen to be caused by the penis, which formed a U-shaped curve on the abdomen, the convexity of the U being forward, and also by the scrotal sacs, which already contained the testes.

¹ "On the Position and Peritoneal Relations of the Mammalian Ovary," Journ. of Anat. & Phys. 1887.

In *Dipus* the *uterus* resembles that of *Pedetes*, the Fallopian tubes are very short, and the cervix uteri has two ora on its dorsal aspect. The urethra is very long, so that the bladder is an abdominal organ; it opens, however, just beneath the clitoris, at the vulval orifice.

Vascular System.

The *Heart* shows nothing to attract special attention in the ventricles. There is no moderator band in the right. The right auricle shows a well-marked, nearly vertical ridge on the posterior wall (D, fig. 12), lying between the posterior (E) and left anterior (C) caval orifices. It is described by Marshall in the Rabbit as the Eustachian valve ('Practical Zoology,' p. 333), but it is on the wrong side of the postcaval opening to correspond with that structure in man. Its position seems to me to correspond most closely with that of the septum spurium of His. The foramen ovale (B) is patent, and opens into the left auricle by a valvular slit-like opening, exactly as it does when it is patent in man. Two pulmonary veins open into the left auricle on each side. Two pulmonary veins open into the left auricle on each side.

Fig. 12.

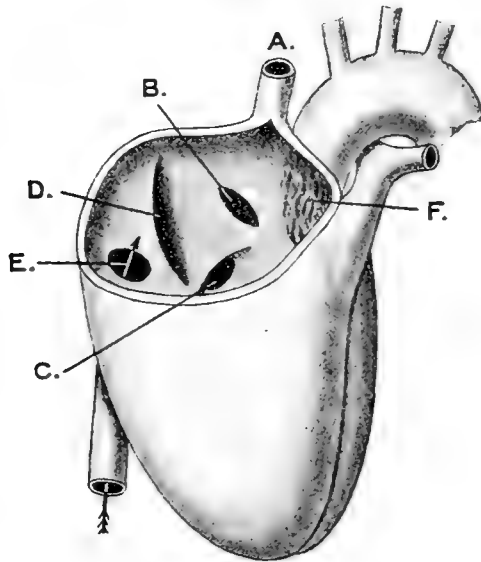

Heart of *Pedetes* with right auricle opened from in front.

- | | |
|------------------------------|--------------------------------------|
| A. Right anterior vena cava. | D. Ridge. |
| B. Foramen ovale. | E. Posterior vena cava. |
| C. Left anterior vena cava. | F. Appendage with muscoli pectinati. |

The branches of the arch of the aorta are, as in man, innominate, left carotid, and left subclavian.

In the foetal specimen the foramen ovale is large, the Eustachian valve is attached to the ventral side of the postcaval orifice. The ridge which has been described in the adult heart is distinct from the Eustachian valve, and is best marked on the ventral

(right) margin of the right precaval orifice. The *musculi pectinati* converge to it.

The *Innominate artery* divides at the right sterno-clavicular articulation into carotid and subclavian; the former runs along the side of the trachea, and at the anterior border of the larynx divides into external and internal carotids.

The *Subclavian artery* gives off the vertebral just before the vagus crosses it; more externally it gives off a *transversalis colli* to the side of the neck, and an internal mammary round which the phrenic nerve loops as it does in man.

The *Axillary artery* divides into two branches of nearly equal size: one of these supplies the axilla, the other goes on as the brachial; the former divides into a ventral branch, which accompanies the internal anterior thoracic nerve to the pectorals and panniculus, and a dorsal branch, which supplies the dorsal part of the axilla, crosses dorsal to the brachial artery and nerves, and passes through the quadrilateral space at the upper part of the arm to join the circumflex nerve: it will thus be seen that the termination of this artery corresponds to the posterior circumflex of human anatomy.

The *Brachial artery* crosses ventral to the inner cord of the plexus, and runs down the arm between the median and ulnar nerves. About the middle of the arm it gives off a superior profunda branch, which accompanies the musculo-spiral nerve to the back. A little above the elbow an external branch is given off which runs superficially to the skin of the outer side of the forearm, while opposite the origin of this is an internal branch which is probably the *anastomotica magna*. After this the brachial artery passes through the fibrous supracondylar foramen with the median nerve, and at the bend of the elbow gives off a small ulnar branch, which, however, ends in the muscles of the forearm. The main artery now divides into a common interosseous, supplying the deep parts of the front and back of the forearm, and the median artery, which accompanies the nerve of the same name into the hand.

The *Thoracic and Abdominal Aortæ* give off the same branches as in the Rabbit. The aorta bifurcates opposite the 6th lumbar vertebra, the caudal artery being given off from the dorsal surface of it, about $\frac{1}{4}$ inch before the bifurcation. The *Common Iliac* arteries bifurcate into external and internal iliacs, close to the inner border of the tendon of the *psoas parvus*.

The *Internal Iliac* runs backward along the dorsum of the pelvis for some little distance; it then gives off a vesico-hæmorrhoidal branch, which divides to supply the bladder, uterus, and rectum, and a gluteal branch, which escapes from the pelvis through the great sciatic notch. The point where the gluteal branch comes off I regard as the division between the anterior and posterior, or rather ventral and dorsal, trunks of the internal iliac (see "6th Collective Investigation Report of the Anatomical Society of Gt. Britain and Ireland," *Journal of Anatomy*, vol. xxx. p. 31).

The ventral trunk of the internal iliac runs backward in the pelvis and soon gives off the sciatic artery; some little distance beyond this it divides into its two terminal branches, the obturator and internal pudic.

The *External Iliac Artery* runs along the brim of the true pelvis to the middle of Poupart's ligament, where it becomes the *Femoral*; this, almost at once, gives off a big branch (*Internal Circumflex*), which sinks into the substance of the thigh, passing round the inner side of the head of the femur. Nearly opposite the origin of this another branch (*External Circumflex*) runs outward and divides into a superficial and deep division, while almost at the same point another artery (*Profunda femoris*) passes backward and breaks up to supply almost all the muscles of the thigh. The continuation of the femoral artery which is now the *Superficial Femoral* runs downward as far as the middle of the inner side of the thigh, where it divides into *Popliteal* and *Internal Saphenous*. The former, which is the larger, runs to the popliteal space; the latter passes superficially across the gracilis (*Adductor cruris*) and reaches the inner side of the leg just behind the inner border of the tibia; it then passes down behind the internal malleolus to the sole of the foot, where it forms a plantar arch superficial to the plantar tendons. From this arch branches are given off to the 2nd and 3rd, and 3rd and 4th digits. At the posterior part of the sole of the foot a small external plantar artery is given off, which accompanies the nerve of the same name and supplies the deep muscles of the sole as well as the 5th digit. The *Popliteal Artery*, after giving off articular branches to the knee-joint, divides into anterior and posterior tibial at the upper border of the popliteus muscle. The *Posterior Tibial* is a small artery which ends in the muscles of the calf. The *Anterior Tibial* passes in front of the popliteus, pierces the interosseous membrane, and supplies the muscles in front of the leg, a very small branch continuing on to the dorsum of the foot.

The Venous System.—The veins were examined, but nothing special was noticed. There are, as has been mentioned, two anterior venæ cavæ.

The *Thymus* is a small irregular mass in the anterior (cephalic) mediastinum; it is about $\frac{1}{2}$ inch long by $\frac{1}{4}$ inch broad, and is divided into two lobes, which communicate across the middle line in two places. In the foetal specimen the thymus is not very large, and it does not relatively occupy much more of the thorax than in the adult. The *Adrenals* are situated as usual just anterior to the kidneys; the left is a good deal larger than the right, and is rather further from the kidney.

The Nervous System.

The Cranial Nerves.—No difference was noticed between these nerves and those of the Rabbit, except that no ansa hypoglossi was found. The sterno-hyoid and sterno-thyroid muscles were supplied by branches from the second and third cervical nerves. As the loop

of communication between the descendens hypoglossi and the upper cervical nerves is always present in the Rabbit, I only wish to record that I failed to find it in this specimen of *Pedetes*; I may have cut it away or this may have been an abnormal specimen.

Brachial Plexus.—There is reason to believe that the limb plexuses of mammals nearly related differ not only in their arrangement but also in the number of spinal nerves which go to form them. I am led to this belief from the fact that in 1887 Professor Paterson figured the limb plexuses of *Atherura fusciculata* (Journal of Anatomy, vol. xxi. p. 611). In 1894 I figured those of *Atherura africana* (P. Z. S. 1894, pp. 688 & 690). At that time I had not read Prof. Paterson's paper, so that the two observations were quite independent of one another. In my animal the fifth cervical nerve certainly entered into the brachial plexus, while in Prof. Paterson's it was quite independent of it. It seems therefore important to figure or describe limb plexuses whenever possible in order to find out how far they are constant structures. In *Pedetes* the brachial plexus is made up of the 5th, 6th, 7th, and 8th cervical nerves and the 1st thoracic. The 5th and 6th nerves unite to form the outer cord, and it is interesting to notice that this cord receives no communication of any kind from the 7th.

The 7th and 8th cervical and 1st thoracic nerves unite to form the inner cord, while the posterior cord is made up of fibres derived from all the roots entering the plexus.

The suprascapular nerve rises from the 5th cervical nerve only; in Paterson's specimen of *Atherura* it came from the 6th, while in my specimen of the same animal it came from the 5th, with a small branch from the 6th. My own observations make me believe that the 5th cervical is its usual origin in mammals.

The nerve to the subscapularis (upper subscapular) comes from the junction of the 5th and 6th cervicals.

The musculo-cutaneous nerve rises from the outer cord, passes above the coraco-brachialis (between it and the humerus) and supplies it; then it gives off two branches to the flexor brevis cubiti (brachialis anticus), and one to the flexor longus cubiti (biceps); after this it becomes cutaneous in the forearm as usual.

The median nerve rises by a head from the inner and one from the outer cord; these unite in the axilla and the nerve runs down the arm on the outer side of the brachial artery, with which it passes through the fibrous supracondylar foramen. At the bend of the elbow a bundle of branches is given off which supplies all the muscles of the flexor surface of the forearm except the flexor carpi ulnaris and the flexor sublimis digitorum; the deepest of these branches, the one supplying the pronator quadratus, corresponds to the human anterior interosseous nerve. A little lower down a cutaneous branch is given off which supplies the lower part of the flexor surface of the forearm and the palm. About the middle of the forearm the nerve divides into two branches of equal size, which run side by side with the median artery to the hand: the more ulnar of these is the larger and supplies all four digital clefts as well as the radial side of the pollex and the ulnar side of the

minimus; the more radial one supplies the thenar muscles and reinforces the second and third digital clefts.

The ulnar nerve comes from the inner cord and runs down on the inner side of the brachial artery, passes deep to the epitrochleo-anconeus muscle, which it supplies, and in the forearm only supplies the flexor carpi ulnaris and the flexor sublimis digitorum, no branch being given to the flexor profundus. After this the nerve passes to the deep part of the hand and supplies all the muscles of the palm except those of the thenar eminence. The usual dorsal cutaneous branch is given off to supply one and a half digits on the ulnar side of the hand. It will thus be seen that in this specimen of *Pedetes* there has been an exchange of fibres usually bound up in the ulnar and median nerves respectively. The flexor sublimis digitorum is entirely supplied by the ulnar, an arrangement which has already been observed in many mammals by Professor K. von Bardeleben; but, on the other hand, the whole of the flexor profundus digitorum and all the digits on their palmar surfaces are supplied by the median.

The internal cutaneous nerve comes from the inner cord and supplies the skin of the inner side of the arm and forearm. There is no separate lesser internal cutaneous, but the lateral cutaneous branch of the second intercostal (intercosto-humeral) crosses the axilla and supplies the skin of the upper part of the inner side of the arm.

The internal and external anterior thoracic nerves come off from the internal and external cords respectively and form a loop from which the pectorals are supplied; from the internal anterior thoracic a large branch (lateral cutaneous nerve of the thorax) passes back to supply the abdomino-humeral portion of the panniculus as well as part at least of the pectoralis quartus¹. The musculo-spiral nerve derives fibres from the dorsal divisions of all the trunks entering the brachial plexus; that, however, from the first thoracic joins it, after the circumflex and subscapular branches have been given off; the nerve winds round the back of the humerus as usual, supplying the triceps, latissimo-olecranalis, anconeus, and skin of the back of the arm and forearm, but no branch is given to the flexor brevis cubiti (brachialis anticus). In front of the external condyle it divides as usual into radial and posterior interosseous, the former supplying three and a half radial digits on their dorsal surfaces, the latter all the extensor muscles of the forearm.

The circumflex nerve comes off from the combined dorsal divisions of the 5th and 6th nerves, so that it can only obtain fibres from these. It pursues the usual course and supplies the teres minor and all three parts of the deltoid.

The middle and lower subscapular nerves rise from the musculo-spiral before the dorsal division of the first thoracic has joined that nerve. The middle subscapular supplies the latissimus dorsi

¹ Professor Birmingham has published a masterly discussion on this subject in the 'Journal of Anatomy,' vol. xxiii. p. 206.

only; the lower supplies chiefly the *teres major*, but, as in man, gives a small branch to the lower part of the *subscapularis*.

Lumbo-Sacral Plexus.—The nerves which enter into this plexus are the 4th, 5th, 6th, and 7th lumbar, and the 1st and 2nd sacral. The *genito-crural* nerve rises from the 4th lumbar, appears on the surface of the *psaos*, and passes down to the middle of *Poupart's* ligament, where it is distributed to the skin of the groin.

The external cutaneous rises from the fourth and fifth lumbar nerves and pursues its usual course to the outer side of the thigh; this it supplies, as well as the *platysma*, which is here well developed. The anterior crural comes from the fifth and sixth lumbar and appears on the outer side of the *psaos*. At *Poupart's* ligament it divides into a superficial and a deep division. The superficial supplies the skin of the front and inner side of the thigh, and, owing to the feeble development of the *ilio-tibialis (sartorius)*, the long saphenous is part of this division. The long saphenous supplies the inner side of the leg as far as the foot, but it lies considerably anterior to the long saphenous artery. The deep division of the anterior crural supplies the deep muscles of the front of the thigh.

The obturator nerve also rises from the fifth and sixth lumbar, and passes through the obturator foramen to supply the obturator externus and adductors.

The great sciatic nerve comes from the sixth and seventh lumbar and the first sacral; before it leaves the sciatic notch it gives off a nerve to the hamstrings and about the middle of the thigh an extra branch to the *flexor cruris lateralis (biceps)*. In the lower half of the thigh it divides into external and internal popliteal, but these nerves, as Paterson points out, are capable of being separated quite up to their commencement. When this was done it was found that both of them, as well as the nerve to the hamstrings, obtained fibres from the sixth and seventh lumbar and first sacral nerves; the fibres of the nerve to the hamstrings were most ventral, then those of the internal popliteal, while the external popliteal fibres were most dorsal.

The nerve to the hamstrings breaks up into five branches; two of these enter the *semitendinosus*, two the *flexor cruris lateralis (biceps)*, while the fifth supplies the *semimembranosus* and *pre-semimembranosus*. It will thus be seen that the *flexor cruris lateralis* has three separate nerves entering it.

Before dividing into external and internal popliteal the great sciatic nerve gives off two cutaneous branches: one of these supplies the skin on the outer side of the leg; the other one, corresponding to the short saphenous of human anatomy, runs down the back of the calf and supplies the outer side of the foot. It has already been said that the great sciatic divides in the lower half of the thigh, and of its two branches the internal popliteal is considerably the larger; this branch supplies the superficial and deep muscles of the calf, and is continued on as the posterior tibial to the sole; here it divides into internal and external plantar, the

former supplying all four toes, the latter passing deep to supply the muscles. The external popliteal nerve divides into musculocutaneous, which runs down among the peroneals to the dorsum of the foot, and the anterior tibial, which breaks up into twigs for the extensor muscles of the leg, one fine branch descending to supply the extensor brevis digitorum muscle.

The small sciatic, internal pudic, and inferior gluteal nerve come from the 1st and 2nd sacral nerves; they have practically the human distribution. The 3rd, 4th, 5th, and 6th nerves form a long cord which runs along the side of the tail.

Summary of Points of Interest.

1. *Pedetes* possesses only two pairs of teats, showing that it is not in the habit of bringing forth many young at a birth; the presence of only one fœtus in the uterus confirms this.

2. The upper incisors of *Pedetes* are smooth, those of *Dipus* are grooved, but the embryo of *Pedetes* also has grooved incisors.

3. The presence of the nail in the palm of *Pedetes*, described by Bardeleben, is confirmed.

4. Bardeleben's description of the radial ossicle or prepollex exactly describes this specimen; in the fœtus the radial ossicle is a definite cartilaginous structure.

5. In the foot a structure apparently serially homologous with the radial ossicle was found; but it was attached to the distal instead of to the proximal row of tarsal bones.

6. The trachea was divided into two by a vertical septum.

7. There was no gall-bladder.

8. A study of the muscles showed that *Pedetes* was allied to the Dipodidæ, but had more hystricomorphine tendencies than those animals.

3. On new Species of Spiders from Trinidad, West Indies.

By FREDERICK O. PICKARD CAMBRIDGE, B.A.

[Received October 18, 1898.]

(Plate LIV.)

In this communication I propose to give descriptions of three new species of Spiders based on specimens collected by Dr. Walter Ince and Mr. Thos. Potter, of Port-of-Spain, Trinidad, and of one new species of which specimens are in the collection of the British Museum from the same locality.

The total number of species of Spiders from this island now represented in the British Museum amounts to eleven only, so that our friends who have been good enough to supply us with material will perceive that further consignments from that locality will be much appreciated.

The examination of Dr. Ince's collection has led to a very

interesting discovery, namely, that a large arboreal Theraphosid indigenous to Trinidad possesses, in both sexes, a stridulating-apparatus similar in general character to those hitherto found only amongst, and supposed to be confined to, the *Theraphosidæ* of the Ethiopian and Oriental Regions.

I had myself previously described one of these Spiders, a female, under the name *Santaremia longipes*, without, however, discovering the "lyra" and "pecten" of the organ in question. This specimen, too, had been deprived of the greater part of the long fringing hairs on the tibiæ and protarsi of the legs, so characteristic in the examples sent by Dr. Ince, and it was therefore relegated to the genus *Santaremia* and regarded as one of the burrowing Mygales. Mr. R. I. Pocock, too, had described a spider, also very worn and rubbed, the locality of which was doubtful, possessing a stridulating-organ, as *Psalmopœus cambridgii*.

There can be now no doubt that the females sent by Dr. Ince from Trinidad are identical with the spider described by Mr. Pocock; and probably the locality, doubtfully quoted as "East Indies," should now be rectified to "West Indies."

The important point, however, lies in the fact that hitherto, although certain members of the family *Dipluridæ* indigenous to the Neotropics possess a very distinct stridulating-organ¹, yet this is the first record of its occurrence amongst members of the family *Theraphosidæ* found in the Neotropics. It is too early to decide yet whether this fact will materially modify the classification of the *Theraphosidæ*, according to the presence or absence of this organ, or not. But the possession of two spurs beneath tibia i. of the male of the Trinidad spider certainly does not tend to simplify the question. None of the stridulating Oriental forms possess any spur beneath tibia i.; and the Trinidad species therefore does not appear to be simply an Oriental form, far away from the headquarters of its kith and kin, but rather a form nearly allied to *Avicularia*, *Tapinauchenius*, &c., abnormal only in the possession of the stridulating-organ.

I may here say that, thanks to the kindness of Mr. Thos. Potter, I have been able to examine a magnificent male of this fine species, all those sent by Dr. Ince having been females.

Being anxious to settle, too, whether this Spider was possibly *Tapinauchenius plumipes* (C. Koch)², I begged from M. E. Simon an example of what he regards as that species taken in Surinam, whence Koch's original type came. Although the Spider sent by M. Simon is exceedingly similar in general character, it, however, possesses no stridulating-organ at all, although the two spurs are present beneath tibia i. Another adult male sent me by M. Simon from Costa Rica possesses both stridulating-organ and tibial spurs, though it is certainly not of the same species as the Trinidad form.

The genus *Tapinauchenius* then, supposing, as we may reasonably

¹ F. Camb. P. Z. S. 1896, pl. xxxv. figs. 1, 2, 3.

² Die Arachniden, ix. p. 67, fig. 733. Hab. Surinam.

do, pending further material from Surinam, that M. Simon's male is identical with Koch's species from the same locality, is distinguished from the very closely allied genus *Psalmopæus* by the absence of the stridulating-organ.

I would like here to call attention to a characteristic feature in these arboreal Theraphosids. Without any doubt the long feathery fringes on the legs assist the passage of the Spider through the air, for though I have never witnessed such a passage in connection with these spiders from Trinidad, I have noticed that an *Avicularia*, if irritated off a tree high up, will leap with legs outspread and fall quite softly, the hairs on the legs resisting the air in the descent. An analogous character can be found on the tail of the Pigmy Phalanger, which assists it in its passage amongst the branches and from branch to branch.

Mr. Potter has also sent me some valuable notes on the habits of these interesting Theraphosids. He tells me that they live in chinks in the bark of trees and in holes in the trunks, being abundant also in the thatched roofs of the houses. The bite of one of these huge spiders proved severe, laying up the victim for a day or two with pains and feverish symptoms, but did not prove fatal. Their food consists of cockroaches and other Orthoptera, grasshoppers, locusts, &c.

Trustworthy information at first hand on these interesting points is very welcome, for although there is no great difficulty in securing information, it is by no means easy to persuade oneself that any of it is worthy of confidence.

The following List contains the names of all the Spiders represented in the Natural History Museum from the Island of Trinidad. It need scarcely be remarked that such a list is merely a beginning, and a very small one at that. Still we are very grateful to the kind correspondents who have enabled us to draw up any list at all, and look forward to a great deal more material being sent over for identification in the near future.

Fam. CTENIZIDÆ.

- | | |
|-----------------------------------|--|
| <i>Pseudidiops hartii</i> Pocock. | Mr. J. H. Hart. |
| <i>Actinopus hartii</i> Pocock. | Messrs. J. H. Hart, Beaven
Rake, and Dr. W. Ince. |

Fam. THERAPHOSIDÆ.

- | | |
|--|---|
| <i>Avicularia avicularia</i> Linn. | Dr. W. Ince, Mr. Beaven
Rake, and the Zoological
Society of London. |
| <i>Psalmopæus cambridgii</i> Pocock. | Dr. W. Ince; Messrs.
Thos. Potter and C. Taylor. |
| <i>Hapalopus incei</i> , sp. n. | Mr. J. H. Hart. |
| <i>Stichoplastus sanguiniceps</i> , sp. n. | Mr. J. H. Hart. |

Fam. DIPLURIDÆ.

- | | |
|---|--------------|
| <i>Brachythele antillensis</i> , sp. n. | Dr. W. Ince. |
|---|--------------|

Fam. FILISTATIDÆ.

Filistata hibernalis Hentz.Dr. W. Ince and Mr.
Beaven Rake.

Fam. PISAURIDÆ.

Lycotenus palustris, sp. n.

Dr. W. Ince.

Fam. ARGIOPIDÆ.

Argiope argentata Fabr.

Mr. J. H. Hart.

Nephila cornuta Pall.

Mr. Beaven Rake.

Fam. CTENIZIDÆ.

ACTINOPUS HARTI Poc. (Plate LIV. fig. 1.)

♂. Total length excl. mandb. 12 mm. Carap. 5.5 × 5.5.
Legs: i. 22—ii. 21—iii. 20—iv. 26.

♀. Total length 15 mm. Carap. 6 × 5.5. (Specimens too soft to allow of further measurements being taken.)

Colour. ♂. Carapace and mandibles dull black-purple. Sternum, mouth-parts, abdomen, and legs olive-brown; pedipalpi somewhat paler.

♀. Carapace and legs dull clay-yellow; mandibles darker. Abdomen dull white-brown.

Structure. ♂. Carapace of the usual character peculiar to the genus. Caput narrowed behind and deeply indentate at the sides.*Eyes.* Anterior row strongly procurved, slightly broader than the posterior. Centrals larger, one-fourth a diameter apart. Laterals set on tubercles two and a half diameters from centrals. Centrals one diameter from margin of clypeus, laterals almost on the margin. Central posteriors smaller than laterals, one transverse diameter from them; the latter three diameters from lateral anteriors. Central posteriors four transverse diameters from central anteriors.

Labium and maxillæ entirely devoid of spinules. Tibia of pedipalp almost as long as the femur, enlarged beneath at the base, more attenuate towards apex. Tarsus globular, slightly bilobate at apex. Bulb, viewed from the outside, short piriform, bilobate at base, strongly geniculate towards apex, which tends slightly outward and downward, with two sharp adjacent carinæ curved spirally round the outside of the apical half of the bulb (Pl. LIV. fig. 1.)

Tarsi and protarsi of the first two pairs of legs numerous spinose. Tibiæ i. and ii. with 10–11 spines and spiniform hairs beneath, toward the apex; the latter with 9–10 smaller sharp spines in addition on the outer side, 3 being in a row close to the apex. Patella iii. with a marginal row on anterior side of 8 stout spines and 12–13 spines on and adjacent to the posterior side, towards the apex. There are besides 20 and upward spines and spiniform hairs on the anterior area of the segment, and a row of four along the dorsal line. The tibia has on the apical margin about 20 spines, with a few smaller ones on the posterior side.

The protarsi and tarsi iii. and iv. are numerously spinous, the latter being densely scopulate, less so in i. and ii. The rastellum of the mandibles is simple, not dentate.

The outer margin of the fang-groove bears five, the inner six stout teeth, with a few smaller ones in the central area towards the base.

♀. General characters the same as in the male with the following exceptions:—The apex of the labium and the anterior margin of the coxæ of the pedipalp are studded with cuspules; those on the former numbering from 6–8. The outer margin of the fang-groove bears 7 teeth, the inner four, while the intermediate area bears 8 smaller cusps. The rastellum is set at its apex with 12–14 short blunt cusps. Tibia i. has five spines on the inner side.

The tarsi of all four pairs of legs are devoid of a true scopula, being furnished with a few hairs only.

A male and two females were in the collection sent by Dr. Ince, the latter probably not mature. Although one cannot be absolutely certain, it is probable that this Spider is the male of *A. hartii* Pocock.

Fam. THERAPHOSIDÆ.

HAPALOPUS INCEI, sp. n. (Plate LIV. figs. 8–10 & 12.)

Total length, ♂ 22·5 mm.; ♀ 27·5.

♂. Carap. 10 × 7·5 mm. Legs: i. 37·5—ii. 33·5—iii. 31·5—iv. 40.

♀. Carap. 11 × 9 mm. Legs: i. 35·5—ii. 32—iii. 30—iv. 42.

Colour. Carapace, legs, and abdomen entirely brown, clothed with olive-brown hairs and pubescence.

Structure. Eyes closely grouped, less than half a diameter apart. Anterior row strongly procurved, laterals slightly larger than centrals.

♂. Carapace very much compressed, in profile. Basal half of protarsus not scopulate, with a stout spine on the outer side and another at apex beneath. Tibia i. with two spurs at the apex beneath; the outer broad at its apex, bearing a spine on each side, the inner spur shorter with single spine on its inner side (Pl. LIV. fig. 8). Tibia i. also bears 3 spines (1–1–1) on the outer side, one being apical.

Protarsus ii. scopulate to base, with one spine on outer side and one at apex beneath. Tibia ii. with 3 spines (1–1–1) on outer side and 3 towards apex on inner side. Femora i. and ii. with a single spine on the anterior apical sides.

Protarsus iii. scopulate to within one-third of the base, with numerous spines. Tibia iii. numerously spinose. Femur iii. with an apical spine (sometimes absent).

Scopula of tarsus iii. and iv. divided by a band of setæ. Protarsus iv. not scopulate on basal half, numerously spinose; tibia iv. spinose but less numerously. Bulb of palpus simple, piriform, its filiform apex directed downward and slightly outward (Pl. LIV.

figs. 9 & 10). Inner basal angle of coxa of pedipalp and apical half of labium numerously spinulose.

The *female* is similar in general characters, the legs being more numerously spinose.

The protarsi of the pedipalp have a pair of spines on the inner side, a little before the middle, and four spines ranged round the apical margin on the inner side and beneath.

The protarsi of the first pair of legs have a pair of spines at the apex beneath, a smaller one on the outer side, and another in the centre towards the base beneath. The tibiæ and protarsi of iii. and iv. are numerously spinose.

This species, of which four adult males and several females were taken by Dr. Ince, appears to be a fairly common Spider in Trinidad. Other examples have been received from Messrs. Beaven Rake and Thomas Potter from the same Island.

The last-named gentleman has very kindly ascertained for me the habits of these small Theraphosids, which burrow in the ground somewhat after the fashion of *Eurypelma*. He says:—"The hole made by this spider is not lined with silk, so far as I can see; and if it is, the coating must be very thin and almost imperceptible. The direction of the burrow is generally at an oblique angle with the surface of the ground. Sometimes the hole is straight for a short distance, but it always winds about, and is more often irregular in direction, like a crab's hole.

"The earth removed by the spider is nearly always thrown away from one side of the aperture in a little mound of coarse pellicles of mould. The specimen I sent was taken from a burrow about ten inches deep and from five-eighths to three-quarters of an inch in diameter. I had two specimens taken from burrows near to each other, and, unfortunately, in captivity the larger spider, being a cannibal, devoured her weaker fellow prisoner." (Pl. LIV. fig. 12.)

Genus STICHOPLASTUS E. Simon,

Ann. Soc. Ent. Fr. 1889, p. 208.

STICHOPLASTUS SANGUINICEPS, sp. n.

♀. Total length 30 mm. (approx.). Carap. 12 long, 10 lat. Legs: i. 38—ii. 35—iii. 33—iv. 46. Protarsus iv. 11. Tibia iv. 8.5.

Colour. Carapace bright orange-red, clothed with short silky yellow hairs. Legs, palpi, and abdomen pale coffee-brown, clothed with fine lighter brown hairs. Sternum and coxæ of legs pale rufous brown.

Structure. In general characters similar to that of the type of the genus, *S. ravidus* E. S., from Venezuela. It differs, however, in the spinulation of the tibiæ of the first two pairs of legs. Tibia i. has two spines in a longitudinal row beneath, and one spine on each side of the apical margin beneath; (*ravidus* has four. *sec.* Simon). Protarsus i. has two spines in a longitudinal row towards the base beneath, and one at the apex beneath.

Tibia ii. has two spines in a longitudinal row beneath, one spine on the outer apical margin, and two on the inner apical margin beneath. Tibiæ and protarsi iii. and iv. are numerous spinose.

The scopula, in the present example, is more or less divided beneath the tarsi of all four pairs of legs. This points to the probability that the example is immature; probably only those of iii. and iv. are divided in the adult.

This species is obviously closely allied to M. Simon's type of the genus, *S. ravidus* E. S., but the difference in the spinulation of the tibiæ of the first two pairs of legs cannot be ignored. It is to be hoped that we shall soon have an opportunity of examining the males of this handsome Spider, which probably occurs under the bark of trees and in holes in the branches (*cf.* E. Simon).

A single female, scarcely adult, was taken by Mr. J. H. Hart, and another, still less mature, was sent by Dr. W. Ince, both from Trinidad.

Genus PSALMOPÆUS Pocock¹.

Santaremia, F. Cambr. (in part, *longipes*)².

Femur iv. without scopuliform pad on the inner side. Legs not spinose; fringes on each side, especially the tibiæ and protarsi, with long silky hairs, longer than the diameter of the segments in the male, shorter in the female. Ocular area much longer than broad, nearly three times; anterior row of eyes distinctly procurved. Coxæ of pedipalp furnished with a highly specialized lyra, which, together with a corresponding pecten on the base of the mandible beneath, forms an organ of stridulation. Tibia i. with a pair of simple slightly curved spurs at the apex beneath, in the male sex only.

PSALMOPÆUS CAMBRIDGII Pocock. (Plate LIV. figs. 2-7.)

(Sub *Santaremia longipes* F. Cambr. P. Z. S. 1896, p. 749.)

♀. Carapace 20 × 17.5 mm.; mandibles 8.5; ocular eminence 4 × 1.75. Legs: i. 77—ii. 68.5—iii. 60—iv. 70.

♂. Carapace 17 × 15.5 mm.; mandibles 7. Legs: i. 80—ii. 75—iii. 62—iv. 75.

♀. *Colour*. Carapace black, entirely clothed with olive-green or ochre-grey pubescence. Margins fringed with shaggy hair. Mandibles clothed at the base above with ochre-grey hairs passing into black towards the apex. Outer side clothed with a pad of short black hairs, fading away below. The margins of the fang-groove and mouth-parts clothed with fiery red hairs. The legs are all clothed with short ochre-grey hairs and olive-grey longer hairs, chiefly noticeable on the sides, where they assume, on the tibiæ, protarsi, and tarsi especially, the form of a plumose fringe. The

¹ Ann. Mag. Nat. Hist. ser. 6, xv. p. 178, pl. x. figs. 3-36.

² Proc. Zool. Soc. 1896, p. 749.

protarsi of all four pairs of legs have a sinuous rust-red band, starting from the base (at the outer side in i. and ii., at the inner side in iii. and iv.), crossing the segment, and terminating towards the apex. The tarsi of all four pairs as well as of the palpi have a central rust-red band above. *Abdomen* clothed with olive-grey and ochre-grey hairs, having also a longitudinal narrow central dark band commencing towards the anterior margin, becoming narrower and more indistinct towards the spinners. On each side, diverging obliquely from a dilatation of the central band, are three slender indistinct brown bars. The shoulders of the abdomen are pale olive, while the apical two-thirds, at least, are suffused with darker brown. The ventral area is clothed with velvety black-brown hairs. Underneath, the tibiæ and patellæ of the palpi and of legs i. and ii. are clothed with a dense covering of deep chocolate-brown hairs. The femora of the first two pairs of legs and of the palpi, and the coxæ and trochanters of all the legs, are clothed with a black-brown velvet covering of hairs. The last two pairs of legs are clothed with brown and ochreous-grey hairs mingled. Protarsi i. and ii. are scopulate entirely to the base, those of iii. almost to the base, those of iv. rather over halfway at the sides, but divided in the centre by a band of dark hairs.

Structure. Carapace in profile gradually rising towards the ocular eminence, moderately compressed. Thoracic fovea straight, transverse. Ocular eminence scarcely raised, much broader, two and a half times, than long. Anterior row of eyes slightly procurved, the longitudinal diameter of the laterals equal to the diameter of the centrals. The centrals $\frac{3}{4}$ of a diameter apart, $\frac{1}{2}$ from the laterals.

Eyes of posterior row smaller than those of the anterior. The laterals of both rows about half a transverse diameter apart.

Inner margin of fang-groove with 14 stout teeth, with two short rows of 5-6 minute teeth opposite the basal two or three on their outer side.

The fringe of hairs on the outer margin becomes obsolete towards the base, giving place to six or seven bristles, very stout at the base, filiform at the apex, set very wide apart (Pl. LIV. fig. 2). These constitute the pecten of the stridulating-organ. The coxæ of the pedipalp (Pl. LIV. fig. 3) bear on the inner side below the suture a thin covering of grey hairs, and further down towards the margin and the base, close to the fringe of red hairs, lie a series of 15 long, curving, clavate, chitinous keys, the anterior ones the longest. These constitute the *lyra* (Pl. LIV. fig. 4) of the stridulating-organ.

The inner anterior angles of the coxæ of the palpus and the apex of the labium are set with numerous minute cuspules. These become more scattered towards the middle of the labium.

The tibiæ of the last two pairs of legs have one spine (iii.) and two spines (iv.) at their apex beneath; of the first two pairs, two spines at the apex beneath. The first pair of sigilla are situate at the base of the labium; the second pair very small, submarginal; the third pair circular, small, but distinct, remote from the

margin; the fourth pair elongate and very deep, impinging on the margin.

The spinners as in *Avicularia*. Tarsal claws 2, those of the first pair of legs with 3 minute teeth on the inner margin in the centre, of the fourth pair with 2 minute teeth in the same position.

Upwards of ten specimens, all of the female sex, many being immature, were taken by Dr. W. Ince on his estate, Dik-Mat-Karo, in Trinidad. A single female in the British Museum collection, already described by me as *Santaremia longipes*, was taken by C. Taylor, Esq., in Trinidad; and an adult male was recently received from T. Potter, Esq., of the Port-of-Spain, Trinidad.

These specimens have proved of exceeding interest, since they furnish us with the first case of a *Theraphosid* (other than a *Diplurid*) belonging to the Neotropics possessing the stridulating-organ on the mandible and the coxa of the pedipalp. I had not noticed this organ when I described Mr. Taylor's specimen under the genus *Santaremia*¹, and the characteristic fringe had been considerably worn from the legs.

But a still more interesting discovery perhaps lies in the fact that these specimens are also undoubtedly identical with the Spider described by Mr. R. I. Pocock as *Psalmopœus cambridgii*, the locality being doubtfully given "East Indies." It seems probable that this locality was an error on the part of the collector, and that Trinidad, or perhaps more broadly "the West Indies," constitutes the headquarters of the species.

This identity being established, *Santaremia longipes* becomes a synonym of *Psalmopœus cambridgii*. The further interesting point arises as to whether this stridulating-organ has been independently developed in this one Spider amongst the Theraphosidæ of the Neotropics, or whether *Psalmopœus* is closely allied to those Oriental forms of Theraphosidæ which, without exception, possess the stridulating-organ.

In one particular character, however, *Psalmopœus* differs from the Oriental forms. In the latter the males have no spur or spurs at the apex of tibia i. beneath, whereas the male of *P. cambridgii* from Trinidad possesses two.

In addition to the above examples, an adult male of a Spider taken in Costa Rica, belonging to the same genus, but probably of a different species, was kindly sent me by M. Simon.

Another Spider, an adult male, was also sent me by the same arachnologist under the name *Tapinauchenius plumipes* (C. Koch) from Surinam. This Spider, very much resembling the males from Trinidad and Costa Rica, has, however, *no trace* of the stridulating-organ. This fact would tend to establish the distinction between the genera *Tapinauchenius* and *Psalmopœus*, much though the Spiders resemble each other in general characters. I may remark that *Tapinauchenius sancti-vincentii* (Walck.)—*sec.* Simon—does not

¹ P. Z. S. 1896, p. 749.

possess any stridulating-organ. Surinam being the locality whence the type of *Mygale plumipes* C. K.¹ came, it seems pretty certain that M. Simon's identification is correct.

Fam. DIPLURIDÆ.

Genus BRACHYTHELE Ausserer,

Verh. z.-b. Ges. Wien, 1871, p. 173; Simon, Hist. Nat. Ar. i p. 180.

BRACHYTHELE ANTILLENIS, sp. n.

♀. Total length 16 mm.

Colour. Carapace and mandibles black, clothed with golden hairs. Abdomen dull brown, clothed with fine black hairs. Legs pale yellow-brown, annulated and spotted with black or dark brown. The palpus has a dark spot at the apex of the femur on each side; the patella has two spots on each side, one near the base, the other towards the apex; the tibia has two dark annulations. Legs i. and ii. are absent. Leg iii. has, besides the same dark spots on the femur, patella, and tibia, two annulations on the protarsus. In the fourth pair of legs the annulations are less distinct.

Structure. There is no special structure different from the general characters of members of the genus. The fang-groove has a single row of 8 stout conical teeth.

A single female of this Spider was taken by Dr. W. Ince in Trinidad. When more specimens of both sexes are available for examination, it will be possible to give the differential characters better definition.

Fam. PISAURIDÆ.

Genus LYCOCTENUS F. Cambr.²,

Ann. Mag. Nat. Hist. ser. 6, xix. p. 95 (Jan. 1897).

LYCOCTENUS PALUSTRIS, sp. n. (Plate LIV. fig. 11.)

♂. Total length 30 mm. Carap. 14×10. Legs: i. 63—ii. 56—iii. 50—iv. 63. Pat.+tib. i. 19—iv. 18.

Colour. Carapace deep mahogany-brown, with a broad margin of yellow-white pubescence. Abdomen deep olive-brown, clothed with short yellow-grey pubescence. Legs brown, clothed with short yellow-grey pubescence and short brown hairs.

Structure. The general characters are the same as in other species of the genus. The unca of the palpal organs is, however, much broader across the middle, strongly projecting in a rounded

¹ Die Arachniden, ix. p. 67, fig. 733, ♂.

² NOTE.—M. Simon, Hist. Nat. Ar. i. 2, p. 300, regards *Lycoctenus* F. Cambr. as a synonym of *Ancylometes* Bert. I do not know whether M. Simon has seen Bertkau's type; but since this latter author quotes the number of pairs of spines beneath tibia i. and ii. as 5, one cannot, on Bertkau's description alone, be satisfied as to their identity. I think it is very likely they are the same, but I have no satisfactory proof of it yet.

angle forwards, while its disc is excavated in a longitudinal oval groove (Pl. LIV. fig. 11). Otherwise the palpal organs very much resemble those of *L. columbianus* F. Cambr. The Spider from Trinidad is, however, very much larger, while the patella and tibia of the first pair of legs are together shorter than those of the fourth pair. In *columbianus* they are equal.

A single adult male was sent by Dr. Ince, from Trinidad.

EXPLANATION OF PLATE LIV.

- Fig. 1. *Actinopus hartii* Pocock, p. 893. Adult male. Palpal bulb, side view.
 2. *Psalmopæus cambridgii* Pocock, p. 896. Adult male. Right mandible.
 3. " " " Coxa of pedipalp, showing "lyra."
 4. " " " Lyra enlarged.
 5. " " " Palpal bulb from the outside.
 6. " " " Palpal bulb from in front.
 7. " " " The two spurs shown on the tibiæ of first pair of legs.
 8. *Hapalopus incei*, sp. n., p. 894. Tibia of the right leg of the first pair, showing the two spurs.
 9. " " " Palpal bulb from the outside.
 10. " " " Palpal bulb from in front.
 11. *Lycocœnus palustris*, sp. n., p. 899. Unca of palpal bulb.
 12. *Hapalopus incei*, p. 894. Sectional sketch of the burrow based on notes sent by Mr. Potter.

4. On the Moulting of the King Penguin (*Aptenodytes pennanti*) in the Society's Gardens. By W. E. DE WINTON, F.Z.S.

[Received October 28, 1898.]

A King Penguin living in the Society's Gardens has lately gone safely through the moult; this moult has been the only one made during the 16 months that this specimen has lived in the Gardens. Two specimens, ♂ & ♀, were purchased on June 23rd, 1897. The female died early in October, from the heat at the end of the summer of last year, before getting acclimatized.

The only opportunity of observing the moult of any member of this order of birds which has been taken advantage of and the facts published is that of the smaller and very widely different species *Spheniscus humboldti* as recorded by the late Mr. A. D. Bartlett in the P. Z. S. 1879, p. 6; and as that was a case of moult from the plumage of the young bird to that of the adult, and the present instance is a simple moult of the adult bird, the facts are thought worth recording.

It is to be regretted that careful notes of the changes were not made daily and more accurate dates noted; but not being primarily interested in ornithology I thought that someone else would have been watching the change, and so can only very roughly describe some of the most striking features of the moult.

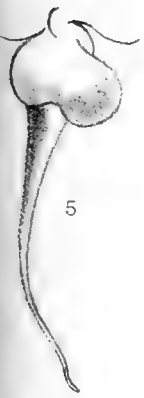
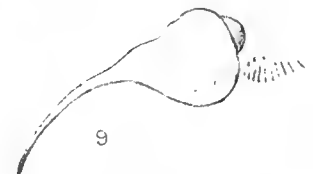
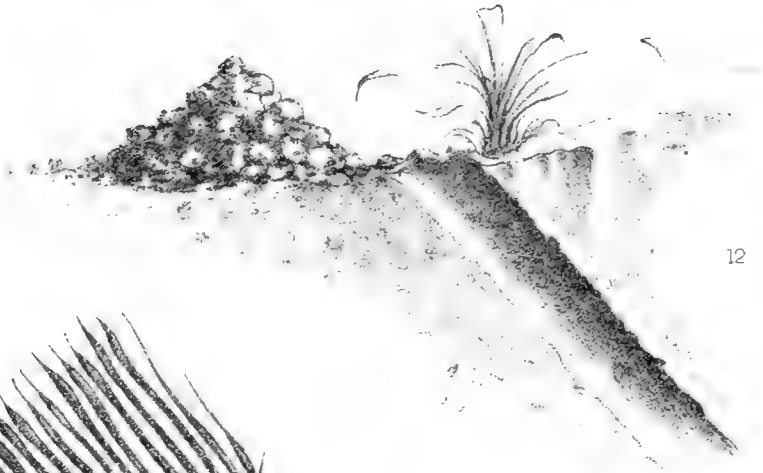
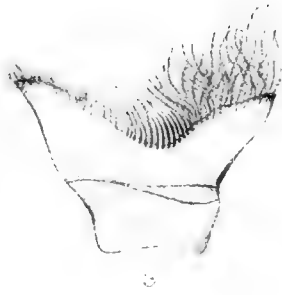



In the latter part of July, before any feathers were shed, it was obvious that the bird was looking very "seedy," in fact sickening for moult. The feathers of all parts lost their lustre, the colour of the beak faded, and the head became grey, as if half of the feathers were wanting; but this I do not think was the case. The bird did not go into the water, and sat moping with half-closed eyes: it ceased to call in its loud manner and to put itself into the usual ludicrous attitudes. This state of things went on for some weeks, but it was not noticed that any feathers were shed until the latter part of August. The keeper tells me that the feathers of the tail were the first to come out, and I saw the bird removing the feathers of the upper and lower tail-coverts in the first week of September. About this time there was a very observable change in the appearance of the bird—the colour had almost entirely gone from the patch at the base of the lower mandible, and, instead of the clear orange colour, this patch appeared to be of a pale horn-colour. The feathers of the back and wings became as brown as withered leaves, so that the bird looked as if it were covered with mud; there was a triangular space on the throat or lower neck where the longer breast-feathers were commencing to fall: the space was never naked, but covered thickly with very short feathers, so that there was only a deep dent in the plumage which increased daily in size. From this time the bird was always very busy picking its feathers off; nearly all of them were removed by its bill, not pulled but pushed off; and there was no general peeling-off in large masses as is described by Mr. Bartlett in the case of the other species.

When the moult was nearly completed and only a few dried-up feathers adhered to the back and upperside of the middle of the wings, the epidermal covering of the orange-coloured patches on the lower mandibles loosened and came off like pieces of parchment or dry bladder. By the third week of September the bird was in perfectly fresh plumage; it was constantly to be seen in the water lying for hours on the surface spread-eagled, which is a very favourite attitude. One week afterwards its feathers seemed full-grown, the colours perfectly fresh and bright, and it constantly croued in its well-known way, especially towards the evening.

It will be noticed that whereas the moult of *Spheniscus*, as recorded by Mr. Bartlett, took place in February–March, the moult of *Aptenodytes* occurred in August–September. The fact that this bird has been in captivity for fully 18 months and that it did not moult in the autumn of last year, proves either that this species does not moult every year, or that captivity retarded the moult. The latter supposition would seem the more probable, seeing that this moult took place at the opposite season to that in which the *Spheniscus* moulted. The same argument might be taken in the case of this latter species; but I consider that the moult is more likely to take place in autumn (that is, in February–March) in the Antarctic Seas, than in spring, for this would clash with the nuptial season if early, and with the rearing of the young if taken

later. I think, therefore, that this bird must have carried its feathers 18 months.

The dried-up appearance of the small feathers of the back and wings has been already mentioned; this phenomenon, I regret to say, was not closely watched and no feathers were recovered. There is no doubt that the feathers became brown and looked like tiny shrivelled leaves. I fully intended to have had some collected, but did not act at once and the opportunity was lost. These feathers adhered to the outer surface of the wings till the moult was complete, and these were the last vestiges of the former plumage to disappear. Whether these feathers actually shrivel or whether they are slimed over and then dry up to this form must be proved by further investigation.

I am not aware that the shedding of the epidermis of the coloured portion of the mandibles of this bird has before been noticed, and I know of no parallel as a part of the moult, though the annual shedding of the wart-like excrescences on the bill of the Rough-billed Pelican (*Pelecanus trachyrhynchus*) and the shedding of the peculiar nuptial mask of the Puffin (*Fratercula arctica*), which had been described by Dr. L. Bureau (Bull. Soc. Zool. France, 1877, ii. p. 377), are well known.

5. On a Collection of Butterflies almost entirely made at Salisbury, Mashunaland, by Mr. Guy A. K. Marshall in 1898. By ARTHUR G. BUTLER, Ph.D., F.L.S., F.Z.S., &c.

[Received November 2, 1898.]

The present consignment of Butterflies, with the exception of fourteen examples referable to ten species, was collected at Salisbury, and therefore is a valuable addition to the Museum series of Mashunaland Butterflies. Mr. Marshall writes:—"I think you will find one or two species among them new to the Museum collection, notably a *Baoris* and a *Kedestes*, both of which Trimen pronounced to be probably new when I first sent them to him some four years ago; but, as he has not referred to them in his recent paper, I presume he has changed his mind. This is the only example of the *Kedestes* which I have yet seen in Salisbury; I first met with it in December 1894 in the warm Mazoe valley, where I took several examples settling on low herbage on the summits of kopjes; in habits it is quite like *K. macomo*.

"I shall be glad to know the name of the unidentified *Mycalesis*; I have only met with three examples in all round Salisbury, one in April 1895, the others this year. I am somewhat in doubt as to the *Teracoli* I have sent you labelled '*pallene*,' for they are practically indistinguishable from the extreme dry form of *omphale*; yet the wet form is certainly not *omphale*, which I do not remember ever to have seen here, but seems referable to *pallene*. The larva

is very similar to, though distinct from, that of *phlegetonia* as observed by me in Natal, but they are not distinguishable in the pupal stage."

One or two other notes in Mr. Marshall's communication will be referred to in the course of this paper. One new species is now described, and two new genera.

N Y M P H A L I D Æ.

SATYRINÆ.

1. MYCALESIS ENA ♂, Hewits.

Salisbury, 16th April, 1898.

"Probably wet form of Trimen's *selousi*, which I wrongly supposed to be *safitza*" (G. A. K. M.). I have no doubt that Mr. Marshall is correct in this opinion, for the chief difference between the two insects consists in the prominence of the ocelli in *M. ena*, the lines crossing the wings being identical in both forms.

2. LEPTONEURA CLYTUS ♂, Linn.

Cape Town, 26th April, 1897.

This, though it has the general aspect on the upperside of the following species, is certainly not congeneric with it.

TORYNESIS, gen. nov.

Differs in neuration from *Leptoneura* in the fact that the sub-costals of the secondaries are emitted from the same point instead of being well separated at their origins. The antennæ with broadly spoon-shaped, instead of cylindrical spindle-shaped, club. Palpi similar, but the second joint more arched and therefore appearing to be wider in the centre, third joint rather more acuminate.

3. TORYNESIS MINTHA Hübn.

♂ ♂, Cape Town, 22nd April, 1897.

TARSOCERA, gen. nov.

Also related to *Leptoneura*, though with more nearly the aspect of *Pseudonympha*: it chiefly differs structurally from *Leptoneura* in the expanded flattened club of the antennæ and the deflexed third joint of the palpi; the club is less spoon-shaped than in *Torynesis* and the neuration is almost identical with *Leptoneura*.

4. TARSOCERA CASSINA Butl.

♂, Cape Town, 5th October, 1896.

So far as I can see, the genus *Leptoneura* will have to be restricted to *L. clytus*, *L. oxylus*, *L. bowkeri*, and *L. dingana*.

5. PSEUDONYMPHA TRIMENI Butl.

♂ ♂, Table Mountain, 15th October, 1896.

NYMPHALINÆ.

6. CHARAXES SATURNUS Butl.

♂ ♂, Salisbury, 30th March and 3rd and 10th April, 1898.

Mr. Marshall labels one of these as “?= *laticincta* Butl.”; but it is not at all like that form, which I believe to be confined to the Nyasa district. I see nothing in Mr. Marshall's example to distinguish it from any other S. African specimens, whereas probably most of the Continental Lepidopterists would have unhesitatingly described the form *C. laticinctus* as a distinct species, instead of a common local aberration.

7. JUNONIA SESAMUS Trim. (and var. *calescens*).

Salisbury, 5000 feet (wet and dry forms), 13th February; dry form, 13th, 16th, 20th, and 23rd March, 1898.

It is quite evident, although Mr. Marshall bred *J. sesamus* from eggs laid by *J. calescens*, that both forms fly together in the wet season: it is therefore better to call *J. calescens* a dry phase than a dry-season form. One of Mr. Marshall's examples is labelled “Bred from egg laid by *P. octavia-natalensis*. Stages: Egg 13th-18th Febr., larva 19th Febr.-19th Mar., pupa 20th Mar.-4th Apr. 1898.” This specimen therefore apparently emerged on the 5th April.

I object to the name “*Precis octavia-natalensis*” for the following reasons:—*Precis* is a synonym of *Junonia*; *octavia* is a distinct West-African species; *natalensis* was a name proposed for the wet form of *P. sesamus*, under the impression that it was a variety of the Western insect, and is objectionable because the genus already contains a species named *natalica*.

8. JUNONIA ARCHESIA Cram.

♂, dry form, Salisbury, 11th May, 1898.

9. JUNONIA CUAMA Hewits.

♂ ♂, ♀ ♀, “dry form,” Salisbury, 9th, 13th, 16th, and 23rd March; 10th April, 1898.

The examples vary a good deal on both surfaces, but do not in the least resemble the following, which Mr. Marshall unaccountably labels as its “wet form” although, as usual, caught at the same time¹.

10. JUNONIA SIMIA Wallgr.

♂, “wet-form”, Salisbury, 27th February; ♀, 13th March, 1898.

11. JUNONIA BOOPIS Trim.

♀ ♀, Salisbury, 4th and 18th June, 1898.

¹ Two very distinct forms of *J. cuama* are forwarded. One of them, which is labelled “Early dry form,” seems to have appeared in the latter half of March; a more heavily marked and more round-winged form, taken a fortnight earlier, looks like its wet form; but is said to be the “First appearance of the dry form.”

12. *HAMANUMIDA DÆDALUS* Fabr.

♂, ♀, "intermediate and dry," Salisbury, 23rd March, 1898.

13. *NEPTIS AGATHA* Cram.

Salisbury, 11th and 22nd May, 1898.

ACRÆINÆ.

14. *ACRÆA SEBENA*, var. *BUXTONI* Butl.

♂♂, Salisbury, 16th February and 24th April, 1898.

15. *ACRÆA RAHIRA* Boisd.

♂♂, Salisbury, 4th May, 1898.

16. *ACRÆA NOHARA* Boisd.

♂♂, ♀♀, Salisbury, 8th and 11th January; 5th, 20th, and 23rd March; 3rd, 10th, 16th, 24th, and 27th April; 11th, 14th, 19th, 22nd, and 29th May; 4th and 18th June.

Some of the specimens are labelled "wet" and some "dry," but I see no appreciable difference between them. As before, the whole are labelled with a varietal name, apparently because in the Mashunaland and Swaziland examples the black spots on the upper surface tend to become smaller than in examples from Natal. I must confess I do not think the name is needed.

17. *ACRÆA DOUBLEDAYI*, var. *AXINA* Westw.

Salisbury, "wet and dry forms," 5th, 13th, 23rd, and 26th March; 9th and 27th April; 11th May; 5th June, 1898.

In this form (the seasonal phases of which do not seem to me to differ) the two or three submarginal dots which usually occur on the primaries of typical *A. doubledayi* are replaced by a continuation of the internervular streaks; the female also rarely shows the subapical white bar of typical *A. doubledayi*; it would therefore seem that *A. axina* is a smaller and localized form of *A. doubledayi*, but intergrades between the two types occur in our Museum series.

18. *ACRÆA ANACREON*, var. *BOMBA*.

♂♂, ♀♀, "wet and intermediate," Salisbury, 2nd January, 19th February, 9th and 16th March, 1898.

I see nothing to distinguish the "intermediate" from the wet form; our intermediate form from Nyasaland shows the fulvous submarginal spots of typical (dry-season) *A. anacreon*. I am, however, grateful to Mr. Marshall for sending us examples of the wet form in each collection, inasmuch as we did not possess it at all until 1895. One of the males now sent has almost lost the black spots on the primaries; a similar but smaller female example was obtained by Mr. Marshall on the 14th August, 1895, at Gijima (*vide* P. Z. S. 1898, p. 191).

19. *ACRÆA NATALICA* Boisd.

♂ ♂, Salisbury, 2nd and 6th March, 1898.

20. *ACRÆA VIOLARUM* and var. *ASEMA* Hewits.

♂, ♀ ♀, Salisbury, 5th March; 9th, 24th, and 27th April, 1898.

These, which represent typical *A. asema* (and should therefore, according to Mr. Marshall, be the dry form of *A. violarum*), are labelled "*violarum-asema*," but a female obtained on the 5th March, which is almost as heavily marked as typical *A. violarum*, is labelled also in the same way though marked with the "wet" sign. To my mind it belongs to the intermediate form, and I think conclusively proves that *A. asema* is only a form of *A. violarum*.

21. *ACRÆA CALDARENA* Hewits.

♂ ♂, ♀ ♀, Salisbury, 19th February; 2nd, 13th, 20th, 23rd, and 26th March; 20th and 30th April; 11th and 14th May; 5th June, 1898.

The seasonal differences appear to be slight in this species: the male seems to differ only in the better marked border to the secondaries in the wet-season, and the female in its smoky suffusion sometimes accompanied by a white belt across the primaries; but at all seasons there seems to be a certain amount of variation even in these characters, though the clouded females do not, apparently, occur in the dry season. A male with very dry characteristics and labelled with Mr. Marshall's dry sign ♂ was taken on the 26th March, and much wetter forms in April, when a wet male and dry female were taken on the same day. It seems to me that these facts are clearly in favour of my view that the seasonal forms of butterflies existed originally as simple variations, and were subsequently accommodated to seasons which afforded them most protection. Thus the males of *A. caldarena*, which show no striking seasonal differences, and which would be hardly more conspicuous at one season than another, are inconstant in their seasonal characters, whereas if the white-banded, smoky female appeared in the dry season it would probably be very conspicuous.

It may be questioned as to what advantage a protected Butterfly, such as an *Acræa*, could gain by being inconspicuous. Although the species of this genus are said to be not only offensive, but elastic and difficult to kill, it is certain that many are permanently maimed by birds and reptiles which (presumably) seize them for the first time, or have not become satisfied of their inedibility.

LYCÆNIDÆ.

22. *ALÆNA NYASSÆ* Hewits.

Salisbury, 3rd and 16th April, 15th May, 1898.

One of the males, having white spots in the cell, was wrongly labelled ♀.

23. *ALÆNA AMAZOULA* Boisd.

Salisbury, 13th, 16th, and 20th March, 1898.

Judging by the specimens now sent and one or two previously in the collection, the Mashunaland examples seem to be decidedly larger than those of Natal.

24. *CATOCHRYSOPS HYPOLEUCUS* Butl.

♂. Gadzima, 4200 feet, Umfuli River, Mashunaland, 28th December, 1895.

This is forwarded under the name of "*C. gigantea* Trim.," but, as already pointed out, my typical female of *C. hypoleucus* being identical with this species, my name cannot be set aside. Mr. Trimen supposed the type to be a worn female from Zomba, but that example was far too imperfect to base a description upon: I therefore labelled and described the far more perfect female from the Victoria Nyanza. If I could do so, I would willingly yield the point; but one cannot alter the identity of a type.

25. *CATOCHRYSOPS MAHALLOKOÆNA* Wallgr.

♀ ♀, Salisbury, 28th March and 3rd April; ♂, 19th May, 1898.

26. *NEOLYCÆNA CISSUS* Godt.

♀, Salisbury, 28th March, 1898.

27. *TARUCUS THEOPHRASTUS* Fabr.

♀, Salisbury, 19th February; ♂, 28th March, 1898.

Labelled as *T. sybaris*; but, if distinct from *T. theophrastus* (which I doubt), it cannot be *T. sybaris*.

28. *NACADUBA SICHELA* Wallgr.

♂, Salisbury, 19th May, 1898.

29. *ZIZERA ANTANOSSA* Mab.

♀, Salisbury, 19th May, 1898.

30. *CASTALIUS CALICE* Hopff.

♀, Salisbury, 14th May, 1898.

31. *LYCÆNESTHES ADHERBAL* Mab.

♀ ♀, Salisbury, 14th May and 4th June, 1898.

32. *CACYREUS LINGEUS* Cram.

♂ ♂, Salisbury, 3rd April and 19th May, 1898.

33. *ZERITIS AMANGA* Westw.

♂, Salisbury, 10th April, 1898.

34. *ZERITIS HARPA* Fabr.

♂ ♂, Salisbury, 30th March, 1898.

35. PHASIS THERO Linn.

Cape Town, 5th October, 1896.

A very dwarfed example of this rare species.

36. ASLAUGA MARSHALLI, sp. n.

♀. Allied to *A. purpurascens*, Holland; with more pronounced anal lobe to secondaries: upper surface altogether darker, vinous brown suffused with blackish, with faint purple gloss on basal half; fringes dull white with dusky central band, blacker and somewhat irregular on primaries and interrupting the outer white edging here and there, notably at the extremity of the anal lobe of secondaries, where it becomes quite black: thorax slate-blackish; head and abdomen mostly brown: under surface fleshy clay-brown, irrorated with darker brown; internal area of primaries greyish; fringes rather less strongly banded than above: pectus and base of venter dull white, legs and remainder of venter paler brown than the wings¹. Expanse of wings 32 millim.

Salisbury, 4th June, 1898.

In the West-African *A. purpurascens* there is a well-defined brown line across the under surface of the wings and the upper surface is considerably paler.

37. THESTOR PROTUMNUS Linn.

Simonstown, 30th December, 1896.

38. ALCEIDES MALAGRIDA Trim.

Signal Hill, 22nd February, 1897.

39. MYRINA FICEDULA Trim.

Salisbury, 26th February and 6th March, 1898.

40. APHNÆUS ERIKSSONII Trim.

♂, Gadzima, 13th September, 1895.

This fine and rare species is quite new to the Museum; it is a typical *Aphnæus*, although, strangely enough, the usual silver patches are wholly absent from the under surface.

41. VIRACHOLA LIVIA Klug.

♂, Salisbury, 15th May, 1898.

PAPILIONIDÆ.

PIERINÆ.

42. MYLOTHEBIS AGATHINA Cram.

♂, Salisbury, 19th May, 1898.

¹ The sides of the abdomen appear to be banded with black, but this may have been produced by grease.

43. TERIAS BRIGITTA Cram.

Wet form. Salisbury, 6th March; 2nd, 3rd, and 6th April, 1898.

Dry form. Salisbury, 14th, 19th, and 22nd May, 1898.

I was pleased to receive a male of the dry-season form, which seems to be much rarer than the wet-season male.

44. TERIAS HAPALE Mab.

♂. *Wet-season form.* Salisbury, 16th February, 1898.

A second male (indicated as a var. in the direction of *floricola*) was obtained on the 11th May! This seems to indicate that the wet phase may sometimes occur in the dry season.

♂. *Intermediate form.* Salisbury, 30th March, 1898.

♂. *Dry form.* Salisbury, 4th, 17th, and 20th April, 1898.

Mr. Marshall writes:—"You will notice among the *Terias* that I have pointed out that *T. aethiopica* and *butleri* of Trimen are respectively dry and wet forms of the same species, and thus, taking the synonymy given in your revision, *hapale* must fall as a seasonal form of *senegalensis*. I have not actually proved the case by breeding, but I think you can take my observations on trust now."

Unfortunately Mr. Marshall's dates (upon the specimens forwarded) seem to point to a different conclusion; for he sends wet, intermediate, and dry examples of true *T. hapale*=*aethiopica*, with the signs ♂, ♂, ♂ on their labels, and taken in February, March, and April respectively. Of *T. senegalensis*(=*butleri*) he also sends wet forms taken from February to March and intermediate to dry forms obtained in March and April. Therefore, although *T. floricola* and *T. hapale* may prove to be only variations of the heavily-bordered species, analogous to the narrow-bordered variations of *T. suasa*, there is, at present, no proof that such is the case, and it certainly is not correct to call *T. hapale* the dry form of *T. senegalensis*, because each of these types has its proper seasonal phases.

45. TERIAS SENEGALENSIS Boisd.

Wet form. ♂♂, ♀, Salisbury, 16th February, 6th and 16th March, ♀ 3rd April.

Intermediate to dry. Salisbury, 6th and 13th March, and 2nd to 3rd April.

The extreme dry form was not forwarded: it is represented by *T. bisinuata*.

46. TERACOLUS JOHNSTONI Butl.

Intermediate form. ♀, Salisbury, 22nd May, 1898.

47. TERACOLUS PHLEGYAS Butl.

Wet form. ♂, Salisbury, 19th May, 1898.

Dry form. ♂, ♀, Salisbury, 5th and 18th June, 1898.

I should regard the male of Mr. Marshall's dry form as

“intermediate”: we have a much more pronounced dry-season male.

48. TERACOLUS ANTIGONE Boisid.

Intermediate and dry forms. ♂ ♂, ♀, Salisbury, 19th and 22nd May; 5th and 18th June, 1898.

Mr. Marshall labelled two females of *T. ithonus* (var. *hyperides*) as “*T. phlegetonia*” = *antigone*: one example of the intermediate form is labelled with the wet sign ♂^w, but was taken on the same day as another marked ♂^d, and differs from the true wet form in the total absence of the bright lemon-yellow at the base of the primaries on the under surface and the reddish tint of the secondaries; this must, therefore, have been a *lapsus*, for it is not likely that wet, intermediate, and dry forms (in equal condition) would all be flying within less than a week of each other. The single female obtained, though taken on the 5th June, belongs to the intermediate phase.

49. TERACOLUS ITHONUS Butl.

Wet form. ♂, Salisbury, 9th March, 1898.

Intermediate. ♀ ♀, Salisbury, 22nd and 29th May, 1898.

Dry form. ♂, Salisbury, 5th June, 1898.

The two males are labelled as *T. achine* (intermediate and dry) and the two females as *T. evagore-phlegetonia* (intermediate and dry). The male obtained in March is, however, the typical wet form of *T. ithonus* (= *hero* ♂); the two females obtained in May are the intermediate form of the same species (= *T. hyperides* ♀); and the male obtained in June is the dry form (= *T. ignifer* ♂).

50. TERACOLUS OMPHALE Godt.

Intermediate and dry forms. ♂ ♂, ♀ ♀, Salisbury, 19th, 22nd, and 29th May, 5th and 18th June, 1898.

Mr. Marshall labels all the specimens as “*T. pallene*”; he writes as follows:—“I am somewhat in doubt as to the *Teracoli* I have sent you labelled *pallene*, for they are practically indistinguishable from the extreme dry form of *omphale*; yet the wet form is certainly not *omphale*, which I do not remember ever to have seen here, but seems referable to *pallene*. The larva is very similar to, though distinct from, that of *phlegetonia* as observed by me in Natal, but they are not distinguishable in the pupal stage. I obtained some thirty eggs from marked females of ? *pallene*, intending to submit the moulting larvæ to varying conditions in order to ascertain the range of its specific variation: a large number of eggs proved infertile and of the remainder all the larvæ died before they were half-grown—why I know not.”

I do not believe that *T. pallene* occurs so far to the south as Mashunaland; but in none of its seasonal forms does it resemble *T. omphale*; indeed it belongs to the same section of the genus as *T. daira*. The wet form of *T. omphale* may vary more than is at

present supposed, though our large series shows a considerable range of variation already, but I have not the least doubt that the examples labelled in the present collection "*Teracolus pallene*" are ordinary *T. omphale*.

51. CATOPSILIA FLORELLA Fabr.

♂, ♀, Salisbury, 27th April, 1898.

52. BELENOIS SEVERINA Cram.

♂♂, Salisbury, 19th and 30th March.

Labelled as "wet" and "intermediate"; there is, however, a considerably wetter phase of the species. I should therefore consider both specimens as intermediate.

HESPERIDÆ.

53. SARANGESA SYNESTALMENUS Karsch.

Salisbury, 16th March, 2nd and 30th April, 19th May, 1898.

Mr. Marshall labels this *S. motozioides*, but the latter is much nearer to *S. motozi*. If these nearly related insects were arranged in natural sequence they would stand thus:—*S. pertusa*, *S. synestalmenus*, *S. motozi*, *S. motozioides*, *S. eliminata*. I am quite prepared to hear that they are only forms of one species, but the chances are that *S. motozioides* and *S. eliminata* will hold their own and that *S. pertusa* and *synestalmenus* will prove to be slight variations of the dry form of *S. motozi*; the latter seems to be a wet form in Nyasaland.

54. ABANTIS VENOSA Trim.

♂, Salisbury, 10th April, 1898.

55. PYRGUS SATASEPES Trim.

Salisbury, 7th August, 1898.

Labelled " ? *diomus*, Hpff. ♂." The latter is quite distinct.

56. PYRGUS DROMUS Plötz.

♂, Salisbury, 9th March, 1898.

57. PYRGUS SPIO Linn.

♀, Salisbury, 26th March, 1898.

58. PAROSMODES ICTERIA Mab.

♂♂, Salisbury, 12th March and 20th April, 1898.

59. KEDESTES MACOMO Trim.

Salisbury, 10th April, 1898.

Mr. Marshall sends this as a new species; but it only differs from typical *K. macomo* in the absence of some of the black spots on the under surface of the secondaries: such differences are hardly likely to have a specific value, but it would be interesting

to see whether the examples obtained in the Mazoe valley were quite constant as regards the number of spots; in the three examples of *K. macomo* which Mr. Marshall sent us in 1897 they differ in size, though not in number.

60. *GEGENES LETTERSTEDTI* Wallgr.

♂, Salisbury, 14th May, 1898.

61. *GEGENES HOTTENTOTA* Latr.

♂ ♀ *in copulá*, Salisbury, 19th February; ♂ 14th May, 1898.

It would be interesting to breed this species so as to decide definitely whether the preceding is readily distinct; until the case is proved it is hard to believe that the large sexual patch on the male *G. hottentota* (= *obumbrata*) is not of specific value.

62. *CHAPRA MATHIAS* Fabr.

♀, Salisbury, 19th May, 1898.

63. *PAENARA DETECTA* Trim.

♂ ♂, Salisbury, 12th, 13th, and 30th March; 9th and 10th April; ♂, ♀, 5th and 18th June, 1898.

The last two specimens are labelled "*Baoris* sp. nov."; but, excepting that they have lost two out of the three subapical hyaline dots on the primaries, I see no character by which they could be distinguished from *P. detecta*, and we know that these hyaline dots are exceedingly variable in number.

64. *PLATYLESCHES MORITILI* Wallgr.

♂ ♂, Salisbury, 20th February, 9th March, 11th April, and 5th June, 1898.

65. *RHOPALOCAMPTA PISISTRATUS* Fabr.

Salisbury, 18th June, 1898.

6. Third Report on Additions to the Lizard Collection in the Natural-History Museum¹. By G. A. BOULENGER, F.R.S.

[Received November 15, 1898.]

(Plates LV.—LVII.)

I. *List of the Species, new or previously unrepresented, of which specimens have been added to the Collection since 1894.*

(An asterisk indicates type specimens.)

*1. *Ceramodactylus pulcher* Anders. Herp. Arab. p. 19 (1896).—S. Arabia (*Anderson*).

2. *Ceramodactylus damæus* Lucas & Frost, Proc. R. Soc. Vict. (2) viii. 1895, p. 1.—C. Australia (*Spencer*).

¹ Cf. P. Z. S. 1894, p. 722.

- *3. *Stenodactylus petrii* Anders. Herp. Arab. p. 96 (1896).—Egypt (*Anderson*), Algeria (*Lataste, Werner*).
4. *Gymnodactylus horridus* Burmeister. Reise La Plata, i. p. 309 (1861).—Argentina, Bolivia (*Borelli*).
5. *Gymnodactylus darmandvillii* M. Weber, Zool. Ergebn. p. 163 (1890).—Kalao (*Everett*).
- *6. *Gymnodactylus lorice* Blgr. Ann. Mus. Genov. (2) xviii. 1898, p. 695.—New Guinea (*Loria*).
7. *Gymnodactylus fumosus* F. Müll. Verh. nat. Ges. Basel, x. 1894, p. 833.—Celebes (*Sarasin*).
- *8. *Gymnodactylus jellesmce* Blgr. P. Z. S. 1897, p. 203.—Celebes (*Sarasin*).
9. *Gymnodactylus louisianensis* De Vis, Ann. Queensl. Mus. no. 2, 1892, p. 11.—Fergusson and Woodlark Islands (*Meek*).
- *10. *Pristurus percristatus* Blgr. Ann. Mus. Genov. (2) xvi. 1896, p. 547.—Erythræa (*Ragazzi*).
- *11. *Pristurus phillipsii* Blgr. Ann. & Mag. N. H. (6) xvi. 1895, p. 165.—Somaliland (*Lort-Phillips*).
12. *Pristurus collaris* Stdr.—S. Arabia (*Anderson*).
13. *Gonatodes affinis* Stol.—Penang, Selangor (*S. S. Flower*).
- *14. *Gonatodes africanus* Werner, Verh. zool.-bot. Ges. Wien, xiv. 1895, p. 190.—Usambara (*Werner*).
- *15. *Phyllodactylus elise* Werner, op. cit. xv. 1895, p. 14.—Niniveh (*Werner*).
- *16. *Phyllodactylus siamensis* Blgr., *infra*.—Siam (*S. S. Flower*).
17. *Phyllodactylus unctus* Cope.—Lower California (*Eisen*).
- *18. *Diplodactylus robustus* Blgr. Ann. & Mag. N. H. (6) xvii. 1896, p. 444.—Madagascar (*Last*).
- *19. *Diplodactylus gracilis* Blgr. t. c. p. 445.—Madagascar.
- *20. *Diplodactylus porogaster* Blgr. t. c. p. 446.—Madagascar (*Last*).
21. *Diplodactylus intermedius* D. Ogilby, Rec. Austral. Mus. ii. 1892, p. 10.—New South Wales (*Porter*).
- *22. *Diplodactylus conspicillatus* Lucas & Frost, Proc. R. Soc. Vict. (2) ix. 1897, p. 55.—C. Australia (*Spencer*).
23. *Diplodactylus byrnei* Lucas & Frost, op. cit. viii. 1895, p. 2.—C. Australia (*Spencer*).
- *24. *Hemidactylus isolepis* Blgr. P. Z. S. 1895, p. 531.—Somaliland (*D. Smith*).
25. *Hemidactylus squamulatus* Tornier, Thierw. O.-Afr., Rept. p. 10 (1896).—E. Africa (*Betton*).
- *26. *Hemidactylus smithii* Blgr. P. Z. S. 1895, p. 532.—Somaliland (*D. Smith*).
- *27. *Hemidactylus jubensis* Blgr. Ann. Mus. Genova, (2) xv. 1895, p. 10.—Somaliland (*Bottego, Lort-Phillips*).
- *28. *Hemidactylus yerburyi* Anders. P. Z. S. 1895, p. 640.—Aden (*Yerbury*).
- *29. *Hemidactylus macropholis* Blgr. Ann. Mus. Genova, (2) xvii. 1896, p. 6.—Somaliland (*Ruspoli, Bottego, Ferrandi*).

- *30. *Hemidactylus ruspolii* Blgr. l. c.—Somaliland (*Ruspoli, Bottego, Ferrandi*).
31. *Mimetozone craspedotus* Mocq. Le Natur. 1890, p. 144.—Penang (*S. S. Flower*)¹.
- *32. *Lepidodactylus gardineri* Blgr. Ann. & Mag. N. H. (6) xx. 1897, p. 306.—Rotuma Id. (*Gardiner*).
- *33. *Homopholis heterolepis* Blgr. op. cit. xvii. 1896, p. 447.—Madagascar (*Last*).
- *34. *Pachydactylus affinis* Blgr. t. c. p. 21.—Transvaal (*Ayres*).
35. *Phelsuma breviceps* Bttgr. Zool. Anz. 1894, p. 137.—Madagascar (*Forsyth Major*).
36. *Sphaerodactylus homolepis* Cope, Proc. Amer. Philos. Soc. xxiii. 1886, p. 277.—Panama (*Rosenberg*), Colombia (*Pratt*).
37. *Lepidoblepharis festæ* Peracca, Boll. Mus. Torin. xii. 1897, no. 300, p. 1.—Ecuador (*Rosenberg*).
38. *Holodactylus africanus* Bttgr. Zool. Anz. 1893, p. 113.—Somaliland (*Lort-Phillips*).
39. *Pletholax gracilis* Cope.—Australia (*Eton College*).
40. *Draco beccarii* Ptrs. & Dor.—Celebes (*Everett, Sarasin*).
41. *Draco obscurus* Blgr. Ann. & Mag. N. H. (6) xx. 1887, p. 95.—Borneo (*Everett*).
42. *Gonycephalus dilophus* D. & B.—New Guinea (*Meek, Loria*).
43. *Gonycephalus geelvinkianus* Ptrs. & Dor.—New Guinea (*Doria*).
- *44. *Agama jayakari* Anders. Herp. Arab. p. 65 (1896).—Muscat (*Jayakar*).
45. *Agama flavimaculata* Rüpp.—S. Arabia, Egypt (*Anderson*).
46. *Agama robecchii* Blgr. Ann. Mus. Genova, (2) xii. 1891, p. 6.—Somaliland (*Gillett*).
- *47. *Agama rueppellii* Vaill.—Somaliland (*Paris Mus., Lort-Phillips*).
- *48. *Agama vaillanti* Blgr. Ann. Mus. Genova, (2) xv. 1895, p. 533.—Somaliland (*Donaldson Smith, Hawker*).
- *49. *Agama smithii* Blgr. P. Z. S. 1896, p. 213.—Somaliland (*Donaldson Smith*).
- *50. *Agama lionotus* Blgr. t. c. p. 214.—Somaliland (*Donaldson Smith*).
- *51. *Agama microterolepis* Blgr. Ann. & Mag. N. H. (6) xvii. 1896, p. 22.—Transvaal (*Ayres*).
- *52. *Agama adramitana* Anders. Herp. Arab. p. 31 (1896).—S. Arabia (*Anderson*).
- *53. *Agama phillipsii*, Blgr. Ann. & Mag. N. H. (6) xvi. 1895, p. 167.—Somaliland (*Lort-Phillips, Hawker*).
- *54. *Agama lehmanni* (Strauch), Nikolski, Ann. Mus. Zool. Ac. St. Petersb. 1896, App. p. xiv.—Turkestan (*St. Petersburg Mus.*).

¹ Type of *M. floweri*, Blgr. P. Z. S. 1896, p. 767.

- *55. *Agama zonura* Blgr. P. Z. S. 1895, p. 583.—Somaliland (*Donaldson Smith*).
- *56. *Agama batillifera* Vaill.—Somaliland (*Paris Mus., Gillett, Hawker, Lort-Phillips*).
- *57. *Phrynocephalus euptilopus* Alcock & Finn, J. As. Soc. Beng. lxx. 1897, p. 556.—Baluchistan (*Indian Mus.*).
58. *Amphibolurus imbricatus* Ptrs.—C. Australia (*Horn*).
59. *Diporophora winneckii* Lucas & Frost, Proc. R. Soc. Vict. (2) viii. 1895, p. 3.—C. Australia (*Spencer*).
60. *Uromastix ornatatus* Rüpp.¹—Sinaitic Peninsula (*Anderson*).
- *61. *Anolis peraccae* Blgr. P. Z. S. 1898, p. 108—Ecuador (*Rosenberg*).
- *62. *Anolis elegans* Blgr. t. c. p. 109.—Ecuador (*Rosenberg*).
- *63. *Anolis chloris* Blgr. t. c. p. 110.—Ecuador (*Rosenberg*).
- *64. *Anolis maculiventris* Blgr. t. c. p. 111.—Ecuador (*Rosenberg*).
- *65. *Anolis rosenbergii* Blgr. Ann. & Mag. N. H. (6) xvii. 1896, p. 17.—Colombia (*Rosenberg*).
- *66. *Anolis lemniscatus* Blgr. P. Z. S. 1898, p. 113.—Ecuador (*Rosenberg*).
- *67. *Anolis curtus* Blgr. *infra*.—Costa Rica (*Underwood*).
- *68. *Anolis notopholis* Blgr. Ann. & Mag. N. H. (6) xvii. 1896, p. 17.—Colombia (*Rosenberg*).
- *69. *Anolis granuliceps* Blgr. P. Z. S. 1898, p. 111.—Ecuador (*Rosenberg*).
- *70. *Anolis gracilipes* Blgr. t. c. p. 112.—Ecuador (*Rosenberg*).
- *71. *Anolis holotropis* Blgr. Ann. & Mag. N. H. (6) xv. 1895, p. 522.—Matto Grosso (*Ternetz*).
72. *Enyalioides festæ* Peracca, Boll. Mus. Torin. xii. 1897, no. 300, p. 3.—Ecuador (*Rosenberg*).
73. *Enyalioides heterolepis* Bocourt.—Colombia (*Pratt*), Ecuador (*Rosenberg*).
74. *Stenocercus roseiventris* D. & B.—Jujuy, Argentina (*Borelli*).
75. *Uta symmetrica* Baird.—California (*Van Denburgh*).
- *76. *Sceloporus asper* Blgr. P. Z. S. 1897, p. 497.—Jalisco, Mexico (*Buller*).
77. *Sceloporus dugesii* Bocourt.—Michoacan, Mexico (*Dugès*).
78. *Sceloporus zosteromus* Cope.—Lower California (*Eisen*).
79. *Sceloporus lickii* Van Denburgh, Proc. Calif. Ac. (2) v. 1895, p. 110.—Lower California (*California Acad.*).
80. *Sceloporus cupreus* Bocourt.—Oaxaca, Mexico (*Buller*).
81. *Sceloporus utiformis* Cope.—Tepic, Mexico (*California Acad.*).
82. *Phrynosoma frontale* Van Denburgh, Proc. Calif. Ac. (2) iv. 1894, p. 296.—California (*Christiania Mus., Gilbert*).
- *83. *Chamaesaura tenuior* Gthr. Ann. & Mag. N. H. (6) xv. 1895, p. 524.—Uganda (*Scott Elliot*).

¹ The specimens previously referred to this species belong to *U. ocellatus* Licht. Cf. Anderson, Zool. Egypt, Rept. p. 128 (1898).

84. *Gerrhonotus monticola* Cope.—Costa Rica (*Underwood*).
- *85. *Diploglossus nuchalis* Blgr. *infra*.—Hab.—? (*Werner*).
86. *Varanus gilleni* Lucas & Frost, Proc. R. Soc. Vict. 1895, p. 266.—C. Australia (*Spencer*).
87. *Varanus eremius* Lucas & Frost, t. c. p. 267.—C. Australia (*Spencer*).
- *88. *Varanus brevicauda* Blgr. *infra*.—Nicol Bay, W. Australia (*Clement*).
89. *Xantusia vigilis* Baird.—California (*Van Denburgh, Gilbert*).
- *90. *Ameiva albo guttata* Blgr. Abh. nat. Ver. Magdeb. 1896, p. 112.—Mona, W. I. (*Wolterstorff*).
91. *Cnemidophorus immutabilis* Cope.—Tehuantepec (*Buller*).
92. *Cnemidophorus hyperythrus* Cope.—Lower California (*Bryant, Gilbert*).
- *93. *Cnemidophorus leachii* Peracca, Boll. Mus. Torin. xii. 1897, no. 274, p. 6.—Jujuy, Argentina (*Borelli*).
- *94. *Arthroseps wernerii* Blgr. *infra*.—St. Catharina, Brazil (*Werner*).
- *95. *Blanus aporus* Werner, Zool. Anz. 1898, p. 220.—Cilician Taurus (*Holtz*).
96. *Amphisbæna liberiensis* Blgr.—Liberia (*Büttikofer*).
- *97. *Amphisbæna borellii* Peracca, Boll. Mus. Torin. xii. 1897, no. 274, p. 8.—Bolivian Chaco (*Borelli*).
98. *Agamodon anguliceps* Ptrs.—Somaliland (*Paris Mus., Fischer, Bottego*).
99. *Aporomera fordii* Hallow.—Gaboos (*Kingsley*).
100. *Lacerta mosorensis* Kolombat. Imen. Kralj. Dalmac. ii. p. 26 (1886).—Dalmatia (*Kolombatovic, Bedriaga*).
101. *Latastia hardeggeri* Steind. Ann. Hofmus. Wien, vi. 1891, p. 371.—Somaliland (*Lort-Phillips*).
102. *Latastia neumanni* Matschie, Sitzb. Ges. nat. Fr. Berl. 1893, p. 30.—Aden (*Yerbury*).
- *103. *Latastia phillipsii* Blgr. Ann. & Mag. N. H. (7) ii. 1898, p. 131.—Somaliland (*Lort-Phillips*).
104. *Acanthodactylus savignyi* Aud.—Oran (*Doumergue*).
- *105. *Eremias smithii* Blgr. P. Z. S. 1895, p. 534.—Somaliland (*Donaldson Smith, Bottego, Hawker*).
106. *Eremias striata* Ptrs.—Somaliland (*Bottego, Ferrandi*).
- *107. *Scaptira aporosceles* Alcock & Finn, J. As. Soc. Beng. lxx. 1897, p. 559.—Baluchistan (*Indian Mus.*).
108. *Zonosaurus quadrilineatus* Grand.—Madagascar (*Last*).
- *109. *Zonosaurus maximus* Blgr. Ann. & Mag. N. H. (6) xvii. 1896, p. 448.—Madagascar (*Baron*).
110. *Zonosaurus laticaudatus* Grand.—Madagascar (*Baron*).
111. *Zonosaurus ceneus* Grand.—Madagascar (*Forsyth Major*).
112. *Tracheloptychus madagascariensis* Ptrs.—Madagascar (*Last*).
- *113. *Egernia dahlia* Blgr. Ann. & Mag. N. H. (6) xviii. 1896, p. 233.—Roebuck Bay, N.W. Australia (*Dahl*).

114. *Mabuia planifrons* Ptrs.—Somaliland (*Donaldson Smith, Bottego*), Uganda (*Betton*).
- *115. *Mabuia tessellata* Anders. P. Z. S. 1895, p. 648.—Aden (*Yerbury*).
116. *Mabuia novemcarinata* Anders.—Penang (*S. Flower*).
117. *Mabuia megalura* Ptrs.—E. Africa (*Neumann, Donaldson Smith, Hinde, Bottego*), Shoa (*Ragazzi*).
- *118. *Lygosoma everetti* Blgr. Ann. & Mag. N. H. (6) xix. 1897, p. 504.—Sumba (*Everett*).
- *119. *Lygosoma nigrolineatum* Blgr. t. c. p. 6.—New Guinea (*Anthony*).
- *120. *Lygosoma brevipes* Bttgr. Zool. Anz. 1895, p. 121.—Halmaheira (*Kükenthal*).
- *121. *Lygosoma lorice* Blgr. Ann. Mus. Genova, (2) xviii. 1898, p. 698.—New Guinea (*Loria*).
122. *Lygosoma maindroni* Sauv.—New Guinea (*Anthony*), New Britain (*Willey*).
- *123. *Lygosoma sarasinorum* Blgr. P. Z. S. 1897, p. 210.—Celebes (*Sarasin*).
124. *Lygosoma celebense* F. Müll. Verh. nat. Ges. Basel, x. 1894, p. 836.—Celebes (*Sarasin*).
- *125. *Lygosoma aignanum* Blgr. *infra*.—St. Aignan Id. (*Meek*).
126. *Lygosoma virens* Ptrs.—Trobriand, St. Aignan (*Meek*).
- *127. *Lygosoma longiceps* Blgr. Ann. & Mag. N. H. (6) xvi. 1895, p. 408.—Trobriand Id. (*Meek*).
128. *Lygosoma semoni* Oudemans, in *Semon*, Zool. Forsch. v. p. 142 (1894).—New Guinea (*Meek, Loria*).
- *129. *Lygosoma miotis* Blgr. Ann. & Mag. N. H. (6) xvi. 1895, p. 29.—Fergusson Id. (*Meek*).
- *130. *Lygosoma elegans* Blgr. op. cit. xix. 1897, p. 8.—New Guinea (*Anthony, Loria*).
- *131. *Lygosoma stanleyanum* Blgr. t. c. p. 7.—New Guinea (*Anthony*).
132. *Lygosoma textum* F. Müll. Verh. nat. Ges. Basel, x. 1894, p. 838.—Celebes (*Sarasin*).
133. *Lygosoma subnitens* Bttgr. Abh. Mus. Dresd. 1896–97, no. 7.—New Guinea (*Loria*).
- *134. *Lygosoma nigrigulare* Blgr. Ann. Mus. Genova, (2) xviii. 1898, p. 700.—New Guinea (*Loria*).
- *135. *Lygosoma curtum* Blgr. Ann. & Mag. N. H. (6) xix. 1897, p. 9.—New Guinea (*Anthony*).
- *136. *Lygosoma tetrataenia* Blgr. op. cit. xvi. 1895, p. 30.—Fergusson Id. (*Meek*).
- *137. *Lygosoma kuekenthali* Bttgr. Zool. Anz. 1895, p. 117.—Halmaheira (*Kükenthal*).
- *138. *Lygosoma sorex* Bttgr. t. c. p. 118.—Halmaheira (*Kükenthal*).
- *139. *Lygosoma iridescens* Blgr. Ann. & Mag. N. H. (6) xix. 1897, p. 9.—New Guinea (*Anthony, Loria*).
140. *Lygosoma parietale* Ptrs.—Borneo (*Everett, Brooke, Flower*).

- *141. *Lygosoma ferrandii* Blgr. Ann. Mus. Genova, (2) xviii. 1898, p. 718.—Somaliland (*Ferrandi*).
142. *Lygosoma guineense* Ptrs.—Niger (*Crosse*), Togoland (*Innes*).
- *143. *Lygosoma johnstoni* Blgr. P. Z. S. 1897, p. 801.—Nyasaland (*Johnston*).
- *144. *Lygosoma alfredi* Blgr. *infra*.—Borneo (*Everett*).
- *145. *Lygosoma gastrostigma* Blgr. *infra*.—Nicol Bay (*Clement*).
146. *Lygosoma quadrivittatum* Ptrs.—Borneo (*Cator, Creagh*).
147. *Lygosoma bipes* Fisch.—W. Australia (*Dahl, Clement*).
- *148. *Ablepharus ornatus* Broom, Ann. & Mag. N. H. (6) xviii. 1896, p. 343.—Queensland (*Broom*).
- *149. *Ablepharus tenuis* Broom, t. c. p. 342.—Queensland (*Broom*).
150. *Eumeces blythianus* Anders.—Afridi Country (*Green*).
151. *Scincus hemprichii* Wieg. —Aden (*Yerbury*).
152. *Chalcides mauritanicus* D. & B.—Oran (*Doumergue, Bedriaga*).
153. *Scelotes gronovii* Daud.—Dassen Id. (*Spencer*).
154. *Scelotes occidentalis* Ptrs.—Cameroon (*Bornmüller*).
- *155. *Sepsina ornaticeps* Blgr. Ann. & Mag. N. H. (6) xvii. 1896, p. 448.—Madagascar (*Last*).
156. *Grandidieria rubrocaudata* Grand.—Madagascar (*Last*).
157. *Grandidieria fierinensis* Grand.—Madagascar (*Last*).
158. *Pygomeles braconnieri* Grand.—Madagascar.
- *159. *Pygomeles trivittatus* Blgr. Ann. & Mag. N. H. (6) xvii. 1896, p. 449.—Madagascar (*Baron*).
- *160. *Voeltzkovia mira* Bttgr. Katal. Rept. Mus. Senck. i. p. 116 (1893).—Madagascar (*Boettger*).
- *161. *Chamæleon ellioti* Gthr. Ann. & Mag. N. H. (6) xv. 1895, p. 524.—Uganda (*Scott Elliot, Ansonge*).
162. *Chamæleon hoehnelii* Steind. Sitzb. Ak. Wien, c. 1891, p. 307.—British E. Africa (*Gregory, Jackson*).
163. *Chamæleon fischeri* Reichen. Zool. Anz. 1887, p. 371.—Usambara (*Werner*).
- *164. *Chamæleon jacksonii* Blgr. Ann. & Mag. N. H. (6) xvii. 1896, p. 376.—Uganda (*Jackson*).
165. *Chamæleon spinosus* Matschie, Sitzb. Ges. nat. Fr. Berl. 1892, p. 105.—Usambara (*Werner*).

II. Descriptions of the new Species.

PHYLLODACTYLUS SIAMENSIS. (Plate LV. fig. 1.)

Head longer than broad ; snout rounded, longer than the distance between the eye and the ear-opening, once and one third the diameter of the orbit ; forehead concave ; ear-opening vertically oval, half the diameter of the orbit. Body and limbs moderate. Digits rather short, moderately dilated at the end, with rather narrow transverse lamellæ inferiorly, numbering 12 to 14 under the fourth toe. Snout covered with equal, rather large granules, vertex and back of head with minute granules intermixed with larger ones

rostral twice as broad as deep, with median cleft above; nostril between the rostral and five small scales; 8 upper and 7 lower labials; symphyial triangular, in contact with two chin-shields; a smaller chin-shield on each side of the median pair. Back covered with small granules and trihedral strongly keeled tubercles forming 8 or 10 very regular longitudinal series; on the sides, the enlarged tubercles become juxtaposed, lose their keels, and pass gradually into the rather large, imbricate ventral scales; these form about 20 longitudinal series. Tail covered with imbricate scales, the dorsals keeled; a ventral series of transversely enlarged, lamellar scales. Greyish brown above, with blackish spots or a wide-meshed network; an irregular dark streak on each side of the head, passing through the eye; each labial with a blackish spot; lower parts white; upper surface of tail with whitish, black-edged transverse spots.

Total length	76 millim.	Fore limb	12 millim.
Head	12 "	Hind limb	16 "
Width of head ..	7 ,	Tail	39 "
Body	25 "		

Specimens were obtained by Mr. S. S. Flower at Dung Phya Fai, Siam, at an altitude of 700 feet.

This species is of special interest as the first discovered in the Indian Region.

ANOLIS CURTUS. (Plate LV. fig. 2.)

Head a little longer than the tibia, once and two thirds as long as broad; forehead deeply concave; frontal ridges indistinct; upper head-scales very strongly keeled, largest on the sides of the snout in front of the supraocular regions; scales of supraorbital semicircles feebly enlarged, separated by 7 series of very small scales; 9 or 10 large keeled supraocular scales; occipital smaller than the ear-opening, separated from the supraorbitals by 6 series of scales; canthus rostralis sharp, canthal scales 4; loreal rows 7; 7 upper labials to below centre of eye; ear-opening small, oval, vertical. Gular appendage small. Body scarcely compressed; no dorso-nuchal fold. Scales granular, keeled, slightly larger on the back than on the sides; ventral scales larger, subimbricate, strongly keeled. The adpressed hind limb reaches the nostril; digits rather feebly dilated; 16 lamellæ under phalanges II and III of the fourth toe. Tail little longer than head and body, cylindrical, without crest. No enlarged postanal scales. Brown above, lighter along the middle of the back, with a vertebral series of small black spots forming an interrupted stripe; two angulated brown transverse bands between the eyes.

Total length	107 millim.	Fore limb	21 millim.
Head	15 "	Hind limb	39 "
Width of head ..	9 "	Tail	56 "
Body	36 "		

A single male specimen from *La Estrella*, Cartago, Costa Rica; obtained by Mr. C. F. Underwood.

DIPLOGLOSSUS NUCHALIS. (Plate LVI. fig. 1.)

Lateral teeth with obtuse crowns. Head small; canthus rostralis rounded; ear-opening smaller than the eye-opening; three prefrontals, azygos largest, as long as broad, forming a broad suture with the frontal, separated from the rostral by two pairs of shields; frontal nearly twice as long as broad; parietal on each side separated from the frontal and supraoculars by two shields; occipital shorter and broader than the interparietal; nasal separated from the rostral; a postnasal and two subequal loreals; rostral much broader than the symphysial; suture between the sixth and seventh upper labials below the centre of the eye; five large chin-shields on each side, first in contact with the lower labials. Body elongate, roundish-subquadrangular. 38 scales round the middle of the body; dorsals finely striated, keelless. Limbs separated when adpressed; digits rather short, fourth considerably longer than third; claws exposed. Tail feebly compressed; caudal scales not keeled. Pale olive above, with small blackish spots and a pair of blackish streaks along the nape; sides of head and body dark, sharply limited above, with bluish-white, dark-edged spots; whitish beneath.

Total length	270 millim.	Fore limb ..	23 millim.
Head	18 ,,	Hind limb ..	32 ,,
Width of head ..	12 ,,	Tail	160 ,,
Body	92		

A single specimen, of unknown origin; received from Dr. F. Werner.

VARANUS BREVICAUDA. (Plate LVI. fig. 2.)

Teeth acute, compressed. Snout obtuse, shorter than the distance from the anterior border of the orbit to the ear; canthus rostralis distinct; nostril round, slightly nearer the orbit than the end of the snout. Upper head-scales small, granular, subequal, smallest on the supraocular region. Scales on back small, elliptical, tectiform; ventral scales smooth, in 75 to 80 transverse series. Digits short. Tail cylindrical, swollen at the base, not quite so long as head and body, covered above and below with very strongly keeled, subspinose scales. Pale reddish brown or buff above, dotted with blackish, or with pale spots enclosed in a brown network; lower parts white.

Total length	185 millim.	Fore limb	21 millim.
Head	16 ,,	Hind limb	83 ,,
Width of head ..	10 ,,	Tail	90 ,,
Body	79 ,,		

Two specimens, apparently half-grown, from the Sherlock River, Nicol Bay, W. Australia; collected by Dr. E. Clement.

ARTHROSEPS, g. n.

Closely allied to *Arthrosaura* Blgr., but differing in the ventral scales being disposed, like the dorsals, in transverse series only;

the two kinds of scales differing only in the greater breadth and perfect smoothness of the former.

ARTHROSEPS WERNERI, sp. n. (Plate LV. fig. 3.)

Head depressed; snout moderate, obtusely acuminate; body moderately elongate. Frontonasal large, square, a little broader than long; a pair of small præfrontals, forming a suture; one frontal; a pair of fronto-parietals; a pair of large parietals separated by an equally long, narrower interparietal; a pair of small occipitals; four supraoculars; a loreal and a freno-orbital; lower eyelid with a large transparent disk composed of two scales; a chain of small suborbitals; 6 upper and 6 lower labials; chin-shields very large, one azygos and three pairs; collar-shields 7, elongate. Dorsal and lateral scales narrow, hexagonal, imbricate, strongly keeled, passing gradually into the ventrals, which are broader and smooth; 34 scales round the middle of the body, 12 of which are smooth, 29 from occiput to sacrum, 20 from collar-fold to præanal region. Three præanal shields, median narrower, about three times as long as broad. Tail scaled like the body. Brown above, with a yellowish dorso-lateral streak; whitish beneath.

Total length	62 millim.	Fore limb ..	7 millim.
Head	7 "	Hind limb ..	6 "
Width of head ..	6 "	Tail	35 "
Body	20 "		

A single specimen from Blumenau, Sta. Catharina, Brazil; received from Dr. F. Werner.

LYGOSOMA AIGNANUM. (Plate LVII. fig. 1.)

Section *Keneuxia*.—Habit lacertiform; the distance between the end of the snout and the fore limb is contained once to once and one third in the distance between axilla and groin. Snout rather long, pointed. Lower eyelid scaly. Nasals widely separated, entire; no supranasal; frontonasal much broader than long, its anterior border convex and forming a broad suture with the rostral; præfrontals extensively in contact on the median line; frontal as long as the frontoparietals and parietals together, in contact with the first, second, and third supraoculars; five supraoculars, first largest, fifth small; 9 or 10 supraciliaries; frontoparietals distinct, truncated anteriorly where they come into contact with the third supraocular; interparietal a little smaller than frontoparietals; parietals forming a suture behind the interparietal; a large temporal and a large nuchal; three upper labials anterior to the subocular. Ear-opening moderate, smaller than the eye-opening, without projecting lobules. 32 to 36 scales round the middle of the body, all smooth or dorsals faintly tricarinate; dorsals largest, laterals smallest. Præanal scales not enlarged. The adpressed hind limb reaches the shoulder or halfway between the shoulder and the ear. Digits slender, strongly compressed distally; 40 to 42 smooth lamellæ under the fourth toe. Tail

once and two thirds to once and three fourths the length of head and body. Brown above; a black streak on each side of the head, passing through the eye; this streak continued, more or less interrupted, along the side of the body in the female; some dark brown spots on the back; male with a large round black spot above the shoulders; upper lip and lower parts yellowish white.

Total length	220 millim.	Fore limb ..	30 millim.
Head	24 ,,	Hind limb ..	47 ,,
Width of head ..	15 ,,	Tail	140 ,,
Body	56 ,,		

Three specimens from St. Aignan Id., S. of Fergusson Id., D'Entrecasteaux Group; collected by Mr. Meek.

LYGOSOMA ALFREDI. (Plate LV. fig. 4.)

Section *Homolepida*.—Body much elongate; the distance between the end of the snout and the fore limb is contained once and three fifths in the distance between axilla and groin. Snout short, obtuse. Lower eyelid scaly; nostril pierced in a single nasal, which is widely separated from its fellow; frontonasal broader than long, forming a broad suture with the rostral and a very narrow one with the frontal; frontal twice as long as broad, longer than its distance from the end of the snout, as long as the frontoparietals and interparietal together, in contact with the first and second supraoculars; four supraoculars; eight supraciliaries; frontoparietals distinct, a little larger than the interparietal, behind which the parietals form a suture; no enlarged nuchals; fourth to sixth upper labials below the eye. Ear-opening round, nearly as large as the eye-opening. 26 smooth scales round the middle of the body, subequal in size. No enlarged præanals. Limbs short; the length of the hind limb equals the distance between the centre of the eye and the fore limb; fourth toe slightly longer than third, with 12 smooth lamellæ inferiorly. Tail thick, a little longer than head and body. Reddish brown above, with darker spots on the nape; blackish spots forming a stripe on each side of the head and body, passing through the eye; whitish beneath.

Total length	68 millim.	Fore limb ..	6 millim.
Head	7 ,,	Hind limb ..	9 ,,
Width of head ..	4 ,,	Tail	35 ,,
Body	26 ,,		

A single specimen (gravid female), from Savu, North Borneo; collected by the late Mr. Alfred Everett.

LYGOSOMA GASTROSTIGMA. (Plate LVII. fig. 2.)

Section *Homolepida*.—Body much elongate; the distance between the end of the snout and the fore limb is contained twice and two thirds in the distance between axilla and groin. Snout short, obtuse. Lower eyelid scaly; nostril pierced in a single



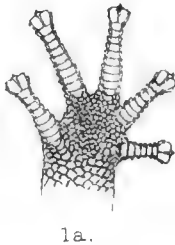
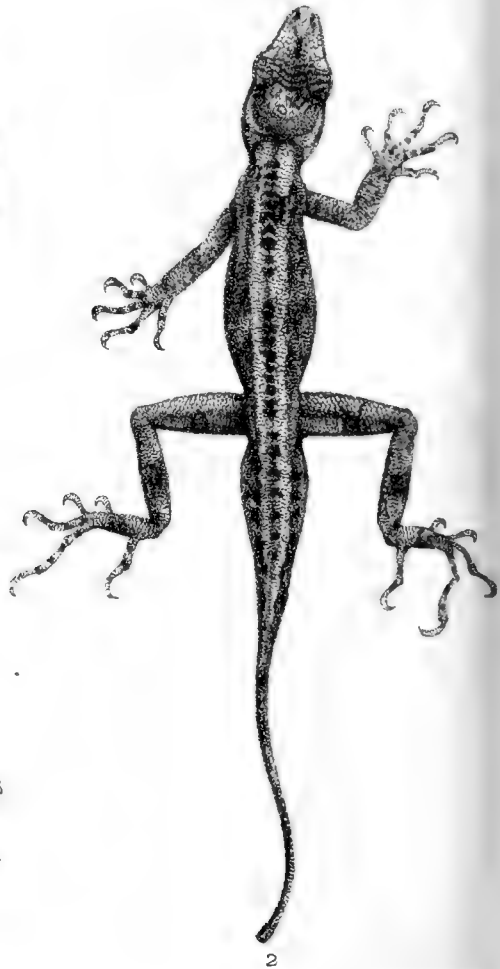
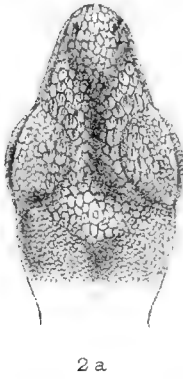
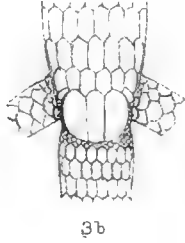

1. *Phyllodactylus siamensis*. 2. *Anolis curtus*.
3. *Arthroseps wernerii*. 4. *Lygosoma alfredi*.



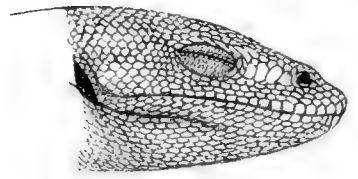

2 a.

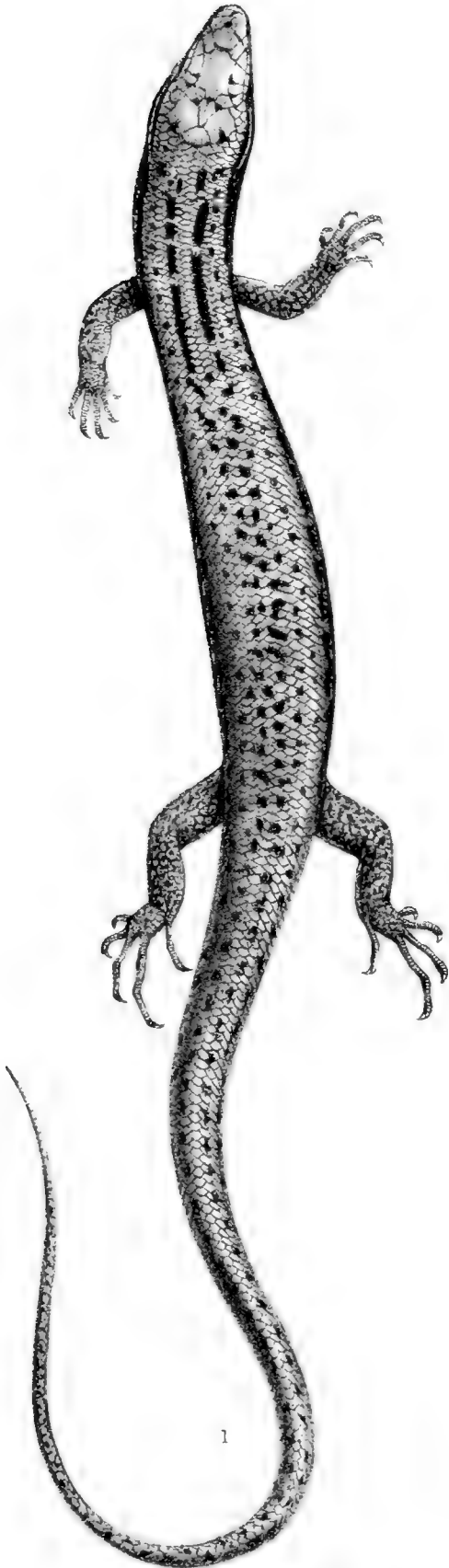

1

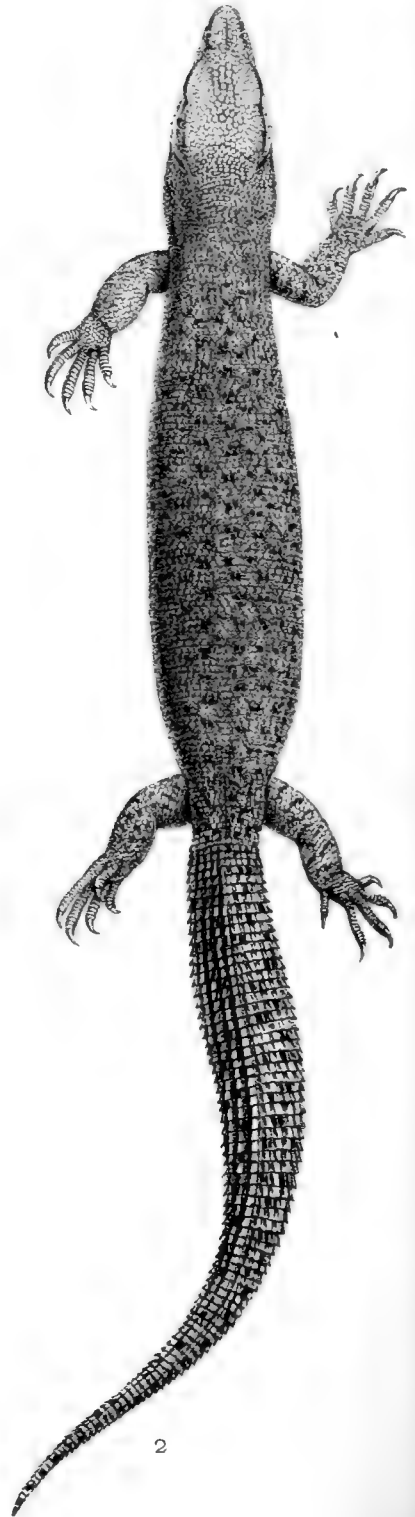

2



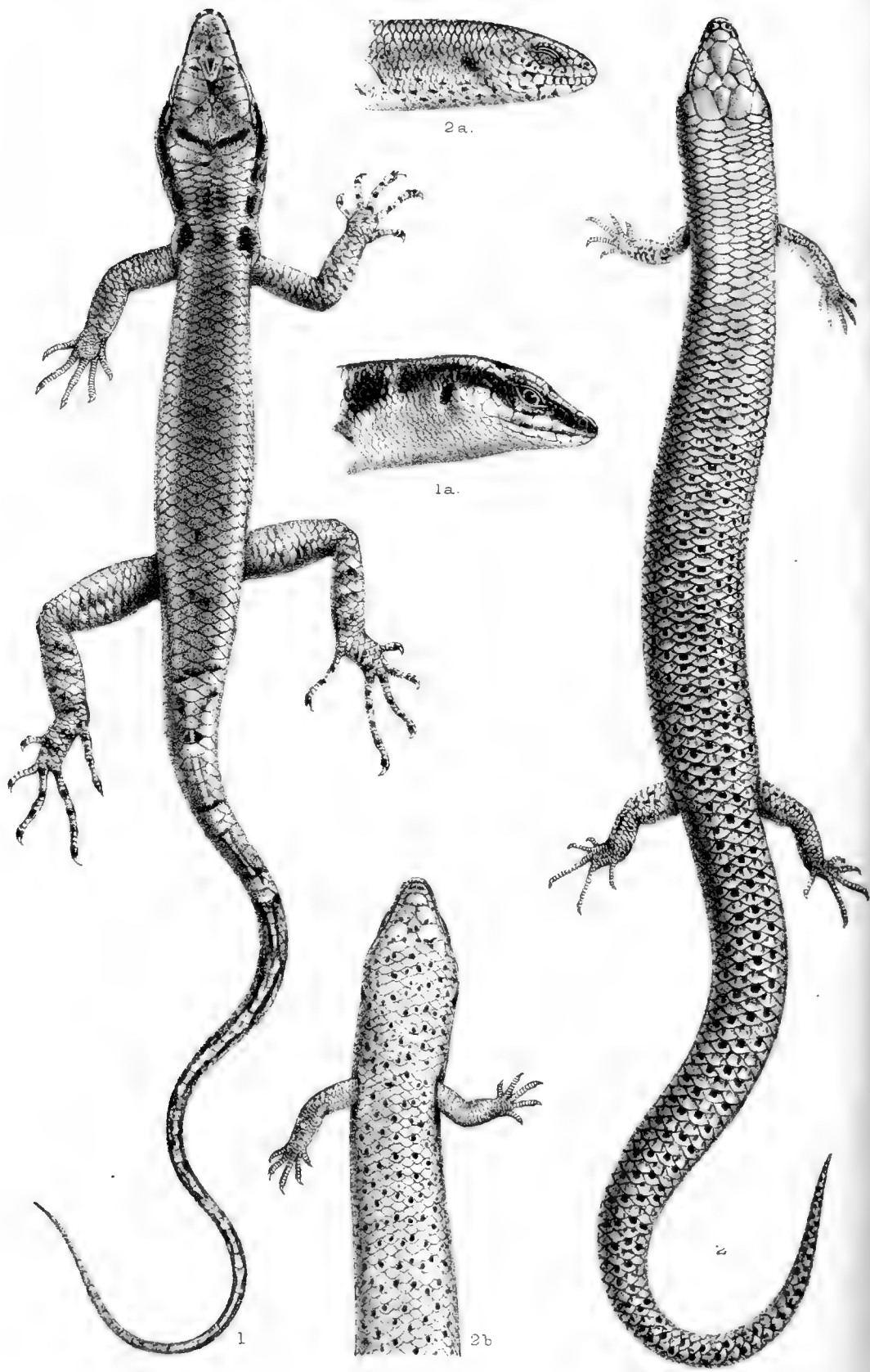

J. Green ad nat lith.

West, Newman imp.

1. *Lygosoma aignanum*. 2. *Lygosoma gastrostigma*.

nasal which forms a suture with its fellow; a vertical groove behind the nostril; frontonasal broader than long, forming a suture with the frontal; frontal once and two thirds as long as broad, longer than its distance from the end of the snout, as long as the parietals, in contact with the first and second supraoculars; four supraoculars, second largest; six supraciliaries; frontoparietals half as long as the interparietal, which entirely separates the parietals; three pairs of nuchals; fifth and sixth upper labials below the eye. Ear-opening oval, oblique, as large as the eye-opening. 26 smooth scales round the middle of the body, median pair of dorsals largest. No enlarged præanals. Limbs short; the length of the hind limb equals the distance between the centre of the eye and the fore limb; third and fourth toes equal, with 14 smooth lamellæ inferiorly. Tail a little longer than head and body. Olive-brown above, almost every scale with a blackish dot followed by a light spot; yellowish beneath, almost every scale with a central black dot.

Total length	245 millim.	Fore limb ..	18 millim.
Head	14 "	Hind limb ..	23 "
Width of head ..	12 "	Tail	125 "
Body	106 "		

A single specimen from the Sherlock River, Nicol Bay, W. Australia; collected by Dr. E. Clement.

This species is most nearly allied to *L. branchiale*, from which it differs in the much larger ear-opening and in the coloration.

EXPLANATION OF THE PLATES.

PLATE LV.

Fig. 1. *Phyllodactylus siamensis*, p. 918.

- 1 a. " " Lower view of foot, × 3.
- 2. *Anolis curtus*, p. 919.
- 2 a. " " Upper view of head, × 2.
- 3. *Arthroseps wernerii*, p. 921.
- 3 a. " " Upper view of head, × 3.
- 3 b. " " Posterior ventral and anal regions, × 3.
- 4. *Lygosoma alfredi*, p. 922.
- 4 a. " " Upper view of head, × 3.

PLATE LVI.

Fig. 1. *Diploglossus nuchalis*, p. 920.

- 2. *Varanus brevicauda*, p. 920.
- 2 a. " " Side view of head, × 2.

PLATE LVII.

Fig. 1. *Lygosoma aignanum*, p. 921.

- 1 a. " " Side view of head.
- 2. " *gastrostigma*, p. 922.
- 2 a. " " Side view of head.
- 2 b. " " Lower view of head and anterior part of body.

December 13, 1898.

Prof. G. B. HOWES, F.R.S., V.P., in the Chair.

The Secretary read the following report on the additions to the Society's Menagerie during the month of November 1898:—

The total number of registered additions to the Society's Menagerie during the month of November was 66, of which 23 were by presentation, 14 by birth, 10 by purchase, and 19 were received on deposit. The total number of departures during the same period, by death and removals, was 106.

The following extract was read from a letter from Mr. Stanley S. Flower, F.Z.S. (dated Gizeh, Egypt, Oct. 27, 1898), in reference to the locality of the Siamang (*Hylobates syndactylus*) which he had presented to the Society on the 17th of October.

“This Siamang was caught in Negri Sembilan, a Malay state (or rather a federation of little kingdoms) which lies north of the settlement of Malacca, and south of the important Malay state of Selangor; it is bounded on the east by Pahang, and cut off from the sea to the west by a little state called Sungei Ujong. In the Malay Peninsula the Siamang seems to be very local; in Perak it is found south of the Perak River, but not apparently anywhere north of it. There are stuffed Siamangs in the Taipang Museum, but all were brought from Kinta in the south. The Siamang certainly does not occur in either Penang or Singapore; but specimens are sometimes brought to Singapore from Sumatra, which is the only other place that I have heard of where they are found wild.”

Dr. Henry Woodward, F.R.S., exhibited and made remarks upon a remarkably abnormal pair of antlers of the Red Deer.

The following papers were read:—

1. On certain Characters of reproduced Appendages in Arthropoda, particularly in the *Blattidæ*. By H. H. BRINDLEY, M.A., St. John's College, Cambridge¹.

[Received October 19, 1898.]

(Plate LVIII.)

In a previous communication (15) I have given an account of some observations and experiments in connection with the reproduction of the legs in the *Blattidæ*, by which it seems established that, in an individual which has not completed its post-embryonic development, amputation or injury of a leg at

¹ Communicated by W. BATESON, F.Z.S.

any point from the femoro-trochanteric suture downwards is followed by the reproduction of the lost parts, with the distinguishing feature that the tarsus consists invariably of only four joints, the normal congenital tarsus possessing five. The present paper is concerned with the structure of the four-jointed tarsus of reproduction, and with cases of reproduction of appendages in other Arthropods with which it possesses certain features in common. In this connection it is desirable to make some reference to the condition of our knowledge of the reproduction of appendages among Arthropods generally. The literature of the subject does not seem to be extensive. Thirty years ago Milne-Edwards (59) summarized the work then published, and since that time the subject has received only sparse attention, especially from the standpoint of experiment. But certain facts have received satisfactory demonstration. [Among Arthropod animals reproduction is always confined to the appendages. Reproduction of portions of the trunk, as is common in the segmented worms, appears never to occur.]

THE PERIOD OF THE LIFE-HISTORY DURING WHICH REPRODUCTION OF THE APPENDAGES CAN OCCUR

appears to be coincident with that of the ecdyses. Hence in Crustacea and Myriapoda the power of reproducing the appendages continues after the attainment of sexual maturity, while in Arachnida and Insecta it ceases with the completion of the post-embryonic development. But in view of the little that is known of the life-histories and ecdyses of Thysanura, Collembola, and some Orthoptera, the above statement must be made with some reserve as regards the Insecta. It is, however, certain that in the case of most of the groups no reproduction of appendages can occur after sexual maturity has been attained, either through a series of ecdyses or on emergence from a pupal state. As regards *Peripatus*, Mr. Adam Sedgwick kindly informs me that he knows of no instances of reproduction of any of the appendages, or of any cases in which an appendage presented features suggesting that it had been reproduced. If regeneration does occur in this isolated genus, a knowledge of its features would be of special interest.

THE PARTS OF AN APPENDAGE FROM WHICH REPRODUCTION CAN COMMENCE.

If an appendage is *wholly* removed from the body it seems that reproduction never occurs. Thus in a crustacean the coxopodite of an appendage, in an insect the scape of an antenna or the coxa of a leg, must be left intact if there is to be reproduction of the extremity. An appendage is therefore never reproduced as a whole by the trunk, but the event is really the formation of a new extremity by a larger or smaller basal portion. Accidental injury to an appendage may theoretically involve any degree of

loss, but the distribution of possible starting-points of reproduction is particulate, being in all cases controlled by the effects of injury or amputation on the portion left attached to the body. Thus in cases where autotomy at a particular region is the invariable result of injury or amputation in any more distal region, it is obvious that the starting-point of reproduction is localized to the spot where the autotomous break occurs. On the other hand, there are cases in which reproduction seems to commence from the actual extremity left on amputation, so that there is no clear localization of the reproductive power.

There are also certain conditions intermediate between the above extremes. As there is such an obvious relationship between autotomy and the reproduction of lost parts, it is unfortunate that our knowledge of the factors controlling the former event should be so imperfect. The term autotomy has received what seems an undesirably wide application by Giard (35) in an attempt to classify many different phenomena under this title, but in what follows its use is confined to the sudden separation of an appendage or part of an appendage in obvious response to an external stimulus. That the event is truly a reflex action, and therefore dependent on the integrity of the nervous system, has been shown experimentally for the legs of several genera of Decapod Crustaceans by the exhaustive experiments by Frédéricq (26, 27, 28), and for the legs of *Locusta* by Frédéricq (29, 30) and Contejean (19).

In the case of other Arthropods the phenomenon is probably of essentially similar nature. But when a series of experiments is conducted on a particular appendage of a single species, the general experience has been that the latent period which elapses between the application of the stimulus and the rupture varies within wide limits; and not only is this the case, but it is also usually found that though a certain degree of injury or amputation in the distal portion of an appendage liable to autotomous loss will almost invariably bring about quite readily the loss of the remaining portion, it does not always do so, though the stump may break away at the usual seat of autotomy after the lapse of a day or two. So much has been said to indicate that it is after all not at present possible to draw any satisfactory distinction between autotomy in the strict sense and the dropping away of the stump of an appendage some time after the loss of the distal portion, which latter event is of common occurrence in some forms which do not ever exhibit autotomy as defined above. And a satisfactory conception of autotomy is also rendered difficult by the fact that in cases where its occurrence is characteristic, even what are apparently the most favourable conditions will sometimes fail to induce it. The whole subject offers much difficulty, but enough has been said to show that it cannot be left out of account in connection with the reproduction of appendages.

CRUSTACEA.—Among Arthropods autotomy and subsequent reproduction have received the greatest degree of attention in the case of the *thoracic limbs* of Decapod Crustacea. On the authority of Hallez (45) it appears that the earliest observations in detail are

those of Réaumur himself on the *legs* of *Palinurus* and those quoted by him as having been performed on Crabs at Guadaloupe by Le Père de Tertres. Réaumur (69, 70) noted that the autotomous rupture always occurred at the groove marking the fusion of the ischiopodite to the basipodite. [The meaning of this peculiar fusion between two leg-joints in Crustaceans and many Tracheates has recently been discussed by Bordage (9).] Réaumur's observation has been often confirmed for all Decapods which exhibit autotomy. Sixty years later the subject was studied by Bodier (4), while during the present century further observations on Decapods have been made by MacCulloch (56), Heineken (46, 47), Couch (21), Goodsir (38), Spence Bate (1), Chantran (18), Putnam (68), Howes (51), and Brook (17). Milne-Edwards (59) and Huxley (52) have discussed the phenomena described¹. During the last few years more extended experiments on autotomy in particular have been made by Frédéricq (*loc. cit.*), De Varigny (74), and Parize (63). It seems certain that the act is reflex in nature; but on other points there is much disagreement among authors, especially whether it is necessary for the limb to come into sharp contact with the carapace. In *Astacus* a few experiments by myself tend to show that the comparatively feeble autotomy of this genus is exhibited only when the carapace is employed as a *point d'appui*. But in this, as in other Decapods, the results of experiments on autotomy are much influenced by the age and general condition of the animal and by the mode of stimulation employed. There is, however, no doubt that most Decapods have a certain region of the limb specialized for autotomous loss, and with this condition has arisen the localization of regeneration. Pouchet (66) and others have pointed out that the loss of a limb at the suture entails comparatively very slight bleeding. It has often been noticed that injury to more distal portions not followed by autotomy results in the eventual loss of all parts up to the suture, though in *Astacus* I have seen distal joints retained two months after mutilation. Goodsir (38) has given a description of a special structure in the basipodite of *Carcinus*, which he regarded as an organ for producing new limbs. The account, however, seems to require confirmation. But whether the regenerative power is localized as above in those Decapods which do not appear to perform autotomy, such as *Crangon*, *Palæmon*, and the young of *Pagurus* (74), is at present uncertain. Moreover, it is doubtful whether the flagellum (endopodite) of the *antenna* of Decapods exhibits true autotomy, and whether regeneration is confined to the protopodite, or may commence more distally. In *Homarus* Brook (17) has mentioned a "throwing off" of the flagellum, and its complete regeneration has been observed by several authors.

ARACHNIDA. *Araneidae*.—Experiments on autotomy and regeneration were made on Spiders by Heineken (46, 47), who found that reflex casting of the *walking-legs* occurred invariably at the suture marking the fusion of femur and coxa. He considered that a

¹ See also Morgan, *Zoöl. Bulletin*, May 1898.

point d'appui was always necessary for rupture, but in other respects his results were very varied. Autotomy did not always occur in a series of individuals of one species, the latent period between stimulus and loss varied greatly, and the results were greatly affected by age and the mode of stimulus, as well as by the particular genera and families employed. Parize (63) has also observed diversities of this kind. In *Tarantula* it has been shown by McCook (57) that the struggles at ecdysis may result in loss of limbs either at distal regions or at the suture. Blackwall (3), who made numerous experiments on regeneration, has not described either autotomous or eventual loss of the stumps of limbs left after partial amputation. More recently Wagner (75, 76) has made experiments on *Tarantula* with the result that section of a leg about its middle is nearly always followed by the animal tearing out the stump up to the suture, an act which seems to be performed in order to prevent loss of blood, which is, as in other Arthropods, great at the point of section, but very slight at the suture. His experiments also lead him to the important and suggestive conclusion that in cases where the stump is not torn off all its tissues degenerate up to the suture, and that therefore regeneration takes place only from the coxa. But as there is no doubt that there is among Spiders much variation of autotomy, it is possible that in some forms regeneration may commence from points distal to the suture.

Scorpionidae.—Mr. R. I. Pocock informs me that it is practically certain that autotomy does not occur in this group, nor has any account of the regeneration of lost appendages been published. He has, however, examined certain specimens in the British Museum, whose history is unknown, but which are almost certainly instances of partial regeneration of the *walking-legs*. Two of these cases have recently been kindly shown to me by Mr. Pocock, and certainly suggest that in Scorpions regeneration commences from the actual seat of injury and is not confined to one particular region of a limb.

MYRIAPODA.—On the regeneration of appendages in Myriapoda but few observations are recorded, and none are of recent date. Autotomy does not seem to occur in this group. Newport (61) found that in *Julus* the stump of an *antennal* joint was retained, and he concluded that reproduction commenced from the point of amputation, for after ecdysis the regenerated extremity could be clearly distinguished by its lighter colour. In both *Julus* and *Lithobius* he observed *legs* regenerated from the coxa after loss brought about by unknown causes.

INSECTA.—Among Insecta the reproduction of lost appendages is known to occur in certain genera of Collembola, Orthoptera, Hemiptera, and Lepidoptera.

Collembola.—Very little is known concerning the life-histories of the Collembola, but it appears that the ecdyses and the power of reproducing the appendages are continued after full growth and sexual maturity have been attained. In these respects, therefore, the group stands in contrast with other Insecta. In

Collembola nothing is known concerning autotomy, and only the reproduction of the *antennæ* has been studied. Bourlet (14) and in greater detail Lubbock (55) have made observations in this case, and concluded that regeneration seemed to commence from the actual point of amputation.

Orthoptera-Saltatoria.—In many genera there is well-marked autotomy of the *posterior* or *jumping-legs*, and, as shown by Heineken (*loc. cit.*), Frédéricq (*loc. cit.*), and Contejean (*loc. cit.*), it occurs at the femoro-trochanteric suture. I am indebted to Mr. J. Graham Kerr for the information that, as noticed by him in the Paraguayan Chaco, administration of chloroform to *Tropinotus* readily causes autotomy at the suture. It is uncertain whether a *point d'appui* is necessary in Saltatoria. Till recently it has been supposed that reproduction of the lost legs does not occur in Saltatoria, on which point reference may be made to the writings of Durieu (24), Frédéricq, Peyerimhoff (65), and Werner (79); but Griffini (42, 43, 44) has lately described some captured specimens which seem to indicate that, as in the *Cursoria*, reproduction of the *legs* occurs in some at least of the Saltatoria during post-embryonic development, and that it commences from the femoro-trochanteric suture. In the nymphs of certain forms regeneration of the *antennæ* has been observed by Graber (39), after he had amputated them near the basal joint. He also records that repair occurred in the wing-covers after pieces had been snipped out with scissors.

Orthoptera-Cursoria.—Many Phasmidæ exhibit autotomy of the *legs* during the later periods of immaturity and during the adult state, but our information on the subject is not very extensive. As he has described in an interesting series of papers, Bordage (5, 6, 7, 8, 10) has found that autotomy at the femoro-trochanteric suture was easily obtainable with several different kinds of stimuli, though the latent period between stimulus and rupture was considerably modified by such factors as age, sex, and mode of stimulus. His experiments seem to show that autotomy may occur either with or without a *point d'appui* being employed. Scudder (72) did not observe autotomy in *Diapheromera*, but the mutilated extremity of a leg eventually fell away up to the suture. In these forms reproduction of the limb may occur not only at the suture but from more distal points.

As regards the *legs* of Blattidæ, my previous paper gives the facts which seem to demonstrate that their loss not infrequently takes place by a feebly developed autotomy at the femoro-trochanteric suture. Regeneration may commence at this point or from the stump of either femur or tibia, but not from any part of the tarsus. The stump of this latter region may be retained for some time after mutilation, but it is invariably dry and shrivelled. The *antennæ* of Blattidæ are certainly capable of reproduction. The earliest observations seem to be those of Heineken (46) on *Leucophaea*. He cut off the *antennæ* "near the base," but did not notice the effects of the injury or whether the reproduction

seemed to commence from the two large basal joints or from one of the smaller ones borne by them.

Neuroptera.—Watson (77) has observed that in the larva of *Agrion* amputation of a leg "close to the body" was followed by reproduction by the next ecdysis. Lubbock (54) found that the terminal joints of the *antenna* in nymphs of *Chloëon* were not reproduced.

Lepidoptera.—It is stated that autotomy occurs in the imagos of certain forms, but as there is no regeneration the point is not of present interest. Several authors have described deformities and reproduction in the *legs* of imagos after amputation performed on their larvæ or pupæ. But in this group the great uncertainty as to the relationships between the several parts of the larval and pupal appendages and those of the imago presents great difficulties to the study of reproduction. Gonin (37), in a recent revision of the structure of the larval legs just before pupation, concludes that only the extremity of the developing pupal leg projects into that of the larva. Hence amputation of the latter at its base removes only the tarsus of the former, and so on. Till the details of metamorphosis are better understood our knowledge of reproduction of appendages in *Lepidoptera* must remain very slight. Réaumur (71) obtained negative results by amputating the legs in the larva of *Vanessa*; while Newport (61) found that the same method of experiment resulted in either complete or partial development of the injured limbs in the imago. He concluded that regeneration commenced from the seat of injury wherever situated. Mélise (58) agreed with this on the strength of his own experiments on the larva of *Sericaria*. Watson (77) obtained reproduction of the legs in *Platysamia* after injuring those of the larva. In a discussion of the diverse results of Réaumur and Newport, Künckel d'Herculais (49) considers that while the former destroyed the histoblast rudiment of the imago leg, the latter merely mutilated it; but Gonin (37) holds that this explanation is insufficient in view of the non-agreement in position of the similarly named regions of the larval and pupal limbs.

As there can be little doubt that reproduction of the appendages can occur in members of other Arthropod orders than those which have received experimental enquiry, the preceding summary of our present knowledge of how far the power of commencing a new growth is confined to one region or distributed more generally in an appendage is, of course, very incomplete. Enough is known, however, to establish that there is a considerable range of variation in this respect between the members of different orders and to some extent between members of the same order. In cases where autotomy in the strict sense of sudden rupture of a limb either in immediate or almost immediate response to a stimulus is most clearly exhibited, it is a necessary result that reproduction is initiated from one particular point, especially where, as in *Crustacea*, the regenerated region can be seen sprouting from the stump and covered only by a thin cuticle. But in *Tracheata* it is

a more difficult matter to be sure as to the exact starting-point of reproduction and the way in which the new growth is elaborated; for in these forms it does not project beyond the stump, and hence it is visible only at the ecdysis which liberates it. [It is of interest that the comparatively exposed condition of the new growth in Crustacea is correlated with an aquatic habit, and its protected condition with the terrestrial habit of the Tracheata; though only a bare suggestion that contact with hard surfaces, as on land, might more readily injure a new and delicate structure is permissible.] In the occluded condition of the new growth in Tracheates there is necessarily involved a disturbance in the normal relations between the chitinous investment of the stump and the subjacent hypodermis. As development of the regenerated extremity proceeds the hypodermis must slip away from the cuticle and towards the base of the limb, leaving a space occupied by the growing extremity. This structure is formed in a curled up condition, and straightens only on liberation at ecdysis, as was first described by Blackwall (3) in the case of Spiders. [Weismann (78) has shown that in the normal development of *Musca* the leg-rudiments are similarly curled up.] This state of things and the displacement of the internal portions of the stump are illustrated for Blattidæ by figures 1 a and 1 b (Plate LVIII.). The regenerated tarsus is curled up and occupies half of the chitinous stump of the tibia, while the soft parts of the latter have largely withdrawn into the chitinous femur. I have failed to make a satisfactory dissection of the regenerated leg within the chitinous coxa and trochanter; but in such a case it would seem that the displacement of parts must be more pronounced than in the case illustrated.

It is obvious therefore that in Tracheata regeneration is complicated by the peculiar occlusion of the new growth, and further enquiry is necessary before we can say exactly what is the history of the soft parts of the stump left by amputation, especially as it is still uncertain whether normal ecdysis involves changes more deeply seated than the mere renewal of the cuticle. If that is the case, as seems suggested by such observations as those of Lubbock (54) on the antennæ of *Chloëon* and of Wagner (*loc. cit.*) on Spiders, there is no longer any question as to a "starting-point" of reproduction, for the new extremity would be a part of the general reconstruction and not a bud. On the other hand, the elaboration of the extremity as an outgrowth from the stump is certainly suggested by the already mentioned observations of Newport on *Julus*. It is, however, very possible that the phenomena of ecdysis differ considerably in the several groups.

THE RELATIVE SIZE AND GROWTH OF REPRODUCED APPENDAGES.

The peculiar fact that it is a constant feature of reproduced appendages in certain cases that they differ in structure from the normal congenital appendages they replace will be dealt with later on. At present only the size and growth of the regenerated

structures as a whole will be considered. A regenerated appendage, or part of an appendage, is always smaller than its fellow, provided that the latter is of congenital origin or is a reproduced structure of earlier date. This natural state of things was first understood rightly by Réaumur, the pioneer of the study of reproduction of lost parts. He corrected the assumption of previous authors that such instances were cases of congenital asymmetry. Nearly all accounts of the reproduction of Arthropod limbs agree in stating that if there are still several ecdyses to be accomplished, the reproduced limb grows with special rapidity so as to approximate or equal in size its congenital fellow.

In Crustacea observations in this respect are recorded by certain of the authors already mentioned (17, 18, 68), from which it appears that some of the appendages of Decapods when reproduced attain their normal size more rapidly than do others. There is, however, considerable want of uniformity of result for the same appendage, and Brook has recorded that temperature, the kind of food, &c. are important factors in the matter.

The special rapidity of growth of regenerated appendages in Spiders, Myriapods, Collembola, and Phasmidæ has been recorded in works already referred to, and also by Fortnum (25) in the last-named group.

There is evidence that in Crustaceans the regenerated appendage more frequently attains equality with its congenital fellow than is the case in Tracheates—a feature which perhaps has some explanation in the freer mode of growth seen in the former group.

In Blattidæ my own observations show that the growth of reproduced appendages is very rapid. Measurements were made with a micrometer-eyepiece of a few nymphs of *Stylopyga orientalis* averaging .8 cm. in body-length and therefore quite young, the body-length of an adult being about 2.0 cm., as opposed to a length of .5 cm. in newly hatched young. I measured the total length of the *tarsus* in these .8 cm. nymphs, and the total length of the cast cuticles of the corresponding tarsi just after ecdysis and apparently before any appreciable shrinkage had occurred. In four instances of normal tarsi the average increase of length after ecdysis was 13 per cent., while in four cases of reproduced tarsi the increase was 29 per cent.

An obvious result of the specially rapid growth of a reproduced limb is that the disproportion in size between it and its normal fellow is less in cases where regeneration has occurred early in the life-history than in those in which it has taken place near maturity. For instance, the tarsi of the third pair of legs in 20 adults of *Periplaneta americana*, taken haphazard from individuals in which one of the tarsi was normal and the other reproduced, showed by measurement that if the length of the normal tarsus be taken as 100, the mean length of the reproduced tarsi was 96.5. On the other hand, the mean length of the reproduced tarsi of seven nymphs averaging .53 cm. in body-length was found to be 87.1,

when expressed in a similar manner to the above. [The tarsi in this latter case were not from the third pair of legs only, but this would not appreciably affect the validity of the comparison.] Among adults there are occasional cases in which the difference is much greater than 3.5 per cent., and such probably indicate that loss and reproduction have occurred in the later instars. It was noticed that the disproportion between the reproduced tarsus and its normal fellow was somewhat greater in adults of *Stylopyga orientalis* than in adults of *Periplaneta americana* or *P. australasicæ*. This may be due to specific differences in the rate of growth of the reproduced structures, or else to some special liability in the first-named species to accidental loss during the later instars. As in Cockroaches the reproduced tarsus has only four joints, it follows that in cases where one tarsus is normal and its fellow reproduced and the two are of approximately equal lengths, the mean lengths of the joints of the latter are on the whole greater than those of the former. In the case of insects with "complete metamorphosis" reproduced appendages in the imago have always been described as smaller than the normal, though it is possible that they may sometimes become symmetrical, for Newport (61) found that in *Vanessa* larvæ reproduction of a leg commenced two stadia before pupation was accompanied by progressive increase in size.

THE STRUCTURE OF THE REPRODUCED LEGS IN THE BLATTIDÆ.

In addition to the general observations on the natural history of ecdysis recorded in my previous paper, the following facts were noticed during the experiments made in the course of the enquiry into the regeneration of the legs in Cockroaches.

(a) *The Length of the Period between Mutilation and Reproduction.*

As already recorded, the legs of 833 nymphs of *Stylopyga orientalis* were mutilated in various parts and the animals kept in confinement in order that the reproduction of the injured limbs might be observed. In 625 cases out of 1473 mutilations, reproduction occurred. The instances tabulated (see p. 934) indicate the *shortest* periods which elapsed between mutilation and reproduction in different degrees. [The term "reproduction" implies in all cases that regrowth of the mutilated or amputated parts took place with the tarsus in a *four*-jointed condition.]

The total number of cases in which it was possible to keep an exact account of the number of days between mutilation and the ecdysis succeeding, and from which the instances recorded in the table were taken, was hardly large enough to permit more than a mere suggestion that reproduction may take place in a shorter time in early nymphs than in nymphs approaching maturity, and that it may take place among the latter more rapidly in males than in females. There is, however, some definite evidence that reproduction of the tarsus alone may occur within a shorter time than that of the more proximal regions of the leg. It is probable that in

TABLE A.

Age or size of individual at the ecdysis which liberated the reproduced appendage.	Number of days between mutilation and ecdysis.	Reproduction took place of the	Lost parts of other legs in the same individual which were <i>not</i> reproduced at this ecdysis.
Body-length 1.9 cm. } (late nymph). }	81	femur downwards.	
Male (final ecdysis).....	84	" "	
Female (" ").....	90	" "	
Body-length .85 cm. } (early nymph). }	43	tibia downwards.	
Male (final ecdysis).....	87	" "	
Female (" ").....	106	" "	
Male (" ").....	70	tarsus.	
Body-length 1.9 cm. } (late nymph). }	81	"	
Female (final ecdysis).....	90	"	
Male (" ").....	82	"	Tibia downwards.
Body-length 2.05 cm. } (late nymph). } ...	102	"	" "
Male (final moult)	83	"	Femur downwards.
Body-length 2.0 cm. } (late nymph). }	87	"	" "

species with a shorter post-embryonic development than *Stylopyga orientalis* reproduction is more rapid. The latter is an unfavourable form for observations of this kind, but was selected as being the species most easily obtainable in large numbers. However long the interval between mutilation and ecdysis, the reproduced legs were always smaller than their normal fellows, nor could I find any particular differences in size between legs reproduced and liberated by ecdysis after short and long periods respectively. The new growths were distinctly dwarf when they appeared after as many as 220 days after mutilation. In a certain number of cases reproduction did not occur even when much longer periods between mutilation and succeeding ecdysis had elapsed than are given in the above table. Thus, amputation at the tibio-femoral articulation or in the middle of the tibia was not followed by any reproduction after intervals of 102, 112, and 192 days. The parts from the femoro-trochanteric suture were not reproduced after an interval of 116 days in another case. In these same instances, however, the lost tarsus of another leg was reproduced, thus favouring the conclusion that there is a relation between the extent of the injury and the time necessary for reproduction. It seems probable that these exceptional cases of non-reproduction after long periods should be attributed to individual causes. The facts that non-reproduction was always total (*i. e.*, that ecdysis left the limb in the same condition as at mutilation) and that when reproduction did occur it was always complete (*i. e.*, the several regions of the

limb right down to its extremity were present and identifiable) are features generally found in Tracheates. It would appear that the formation of the new appendage is a very rapid process, and the facts are favourable to the view that ecdysis really involves more or less reconstruction of the soft parts as well as of the cuticle. This, however, can hardly be the case in Crustaceans, in which the new growth is distinctly a reproduction of the limb while still covered by a cuticle.

(b) *Relative Dimensions of the Tarsal Joints.*

The reproduced femur and tibia resemble those of the normal congenital limb, though they are always smaller than the latter at their first appearance. In one or two cases I have found the tibia of arcuate form, but this condition was probably due to incomplete straightening from the coiled-up condition before ecdysis. The reproduced tarsus is, however, always four-jointed, though in certain very exceptional cases to be shortly described this condition was not quite fully expressed. It is never five-jointed as in the normal.

The general appearance of a normal and of a reproduced tarsus from the same pair of legs of an adult *Periplaneta americana* is shown in Plate LVIII. figs. 2 & 3. The following table gives examples of the relative lengths of the tarsal joints of both normal and reproduced forms. The measurements were made along the dorsal side and with the tarsi as much extended as possible. It is obvious that this method imposes undue prominence on the lengths of the proximal and terminal joints, on account of the telescoping of the intermediate joints into the above and into each other at their articulations, but the results are sufficient for comparison as the treatment was uniform. The tarsi of small nymphs were measured with a micrometer eyepiece, and those of large nymphs with a sliding screw micrometer kindly lent to me by Professor W. F. R. Weldon.

In these tables and later on the several joints of a tarsus or other appendage are for brevity referred to as $j_1, j_2, \&c.$ in the case of normal congenital structures, and as $J_1, J_2, \&c.$ in the case of reproduced structures, the numeration beginning with the proximal joint.

In the following tables the total length of the tarsus was reduced to 100 in each case, and the lengths of the several joints are expressed as percentages.

TABLE B.—*Periplaneta americana.*

5-jointed tarsi. Means of measurements of 115 tarsi from the third pair of legs.

$j_1.$	$j_2.$	$j_3.$	$j_4.$	$j_5.$
53.2	15.6	9.5	4.9	16.8

4-jointed tarsi. Means of measurements of 115 tarsi from the third pair of legs.

$J_1.$	$J_2.$	$J_3.$	$J_4.$
57.4	18.3	6.4	17.9

TABLE C.—*Stylopyga orientalis*.

5-jointed.

4-jointed.

		j_1	j_2	j_3	j_4	j_5		J_1	J_2	J_3	J_4	
Pair I.	Young	38.2	13.9	11.2	7.8	28.3	Mean of 19 cases.	41.5	17.1	10.8	30.2	Mean of 13 cases.
	Adult	40.3	15.5	11.3	7.3	26.3	Mean of 13 cases.	43.9	17.4	9.7	28.6	Mean of 13 cases.
Pair II.	Young	44.7	14.9	10.6	6.7	22.9	Mean of 20 cases.	48.2	17.2	9.0	25.3	Mean of 13 cases.
	Adult	46.2	15.3	10.6	6.3	21.6	Mean of 13 cases.	51.8	17.6	7.7	22.7	Mean of 13 cases.
Pair III.	Young	47.7	16.1	10.6	6.3	18.3	Mean of 20 cases.	51.4	17.5	8.8	21.9	Mean of 15 cases.
	Adult	50.2	16.5	10.5	5.5	17.0	Mean of 13 cases.	55.2	18.1	7.5	18.8	Mean of 14 cases.

The definitely constituted nature of the 4-jointed form of tarsus in both young and adult individuals and on all three pairs of legs is illustrated by Table C, and from the values recorded therein it is obvious that the behaviour of the 4-jointed form is in general agreement with that of the normal tarsus. If the relative values of the several joints in the latter are examined, it is seen that the total length is rather more evenly distributed among the joints in the case of Pair I., than in that of Pair II., and in the case of Pair II. than in that of Pair III. This is most easily seen in the case of the longer joints, j_1 and j_5 , though the shorter intermediate joints are also concerned. In any single individual animal the *total* length of the tarsus is of course greater in Pair III. than in Pair II., and in Pair II. than in Pair I. So that in a longer (more posterior) tarsus j_1 is relatively greater and j_5 relatively smaller than in a shorter (more anterior) tarsus. Now in the case of the 4-jointed tarsi it will be seen that J_1 and J_4 are affected in a similar manner. Again, the values for the 5-jointed tarsi present a strong indication that j_1 is relatively longer in adult than in immature individuals, j_5 being affected inversely. So is it for J_1 and J_4 respectively in the 4-jointed tarsi. The measurements forming the data for constructing Table C were purposely taken from young of all sizes, from newly hatched to over 20 cm. in body-length (penultimate instar); and a consideration of the cases in order of age did not reveal any reliable indication that the above noted alteration in the ratios of j_1 and j_5 was established progressively. The relative increase of j_1 and decrease of j_5 appear to be coincident with the attainment of maturity, and the same is true for J_1 and J_4 . It is admitted that the above statements are based on a comparatively small total of observations, and that

there is difficulty in making very accurate measurements of the shorter intermediate joints; but from a consideration of the individual instances from which the means in Table C were obtained, it is believed that the data are sufficiently reliable to justify what has been said above. It has, moreover, been ascertained that the results are the same when the two sexes are considered separately, as the differences between male and female in the ratios of the several tarsal joints to the whole tarsus are extremely slight, so that the figures tell the same tale whether the two sexes are taken together or separately.

(c) *The Armature of the Tarsal Joints.*

Subject to specific differences the tarsal joints in Blattidæ are provided with a closely-set armature of spines. In addition to the numerous small spines all the joints except the terminal one bear at their distal ends strong spurs or calcares, which are directed ventralwards and outwardly, one on either side. Similar spurs are developed in reproduced tarsi. Examination showed that in both kinds of tarsi the armature is sometimes abnormal. The abnormal conditions met with fall under three heads, as follows:—

- (a) A tarsal joint had more than two spurs. In such cases the commonest condition was the presence of one supernumerary spur on one side.
- (b) A tarsal joint had one of the normal spurs completely absent (there being no scar indicating accidental breaking off).
- (c) A tarsal joint had a spur of normal form placed some distance anteriorly to the proper position at the end of the joint.

The following Table shows the incidence of abnormality observed:—

TABLE D.

		<i>Periplaneta americana.</i>	<i>Periplaneta australasie.</i>	<i>Stylopyga orientalis.</i>
5-jointed tarsi.	Armature normal	15	72	100
	Armature of one or more joints abnormal.....	1	3	0
	Total cases examined.....	16	75	100
4-jointed tarsi.	Armature normal	23	65	46
	Armature of one or more joints abnormal.....	10	6	54
	Total cases examined.....	33	71	100

As in the case of normal spurs, supernumerary ones were always situated on the sides of the tarsal joints and never in the mid ventral line. In all except three cases from *S. orientalis* the supernumerary spurs were placed quite close to the normal spurs. Hence the most common condition—that of *one* supernumerary spur—was expressed as one spur on one side and two on the other. In cases where the total number of spurs on a joint exceeded three there were supernumerary spurs on both sides: for instance five spurs would be expressed as three on one side and two on the other. This tendency to uniformity in the distribution of supernumerary spurs was observed in all cases except in five from *S. orientalis* and one from *P. americana*. In these latter there were either three or four spurs on one side of the joint and only a single (the normal) one on the other. The cases of abnormal armature showed no indication of any relation between the number of supernumerary spurs on a single joint and the extent to which a supernumerary armature occurred in the tarsus as a whole. The joints seemed to vary quite independently of each other in respect of their armature. But on the whole there is obviously a greater frequency of abnormality of the armature in reproduced than in normal tarsi. In this connection it may be noted that Newport observed that the reproduced appendages of Arthropods are particularly liable to disturbances in their armature. Some or all of the normal spines may be absent or there may be supernumerary spines. His observations in this respect were chiefly on Myriapoda and Lepidoptera after injury to the larval appendages. In respect of cases of abnormal armature in the reproduced legs of Blattidæ, it may perhaps be suggested that the additional spines represent the normal terminal armature of a joint whose normal articulation is absent, on the supposition that in the reproduced tarsus one of its four joints is equivalent to two joints of a normal tarsus fused together. There are, however, objections to such a view. The supernumerary spines in 4-jointed as in 5-jointed tarsi were, with only two or three exceptions among all the tarsi examined, grouped closely together in the proper position of the normal spines instead of being situated near the middle of the joint. Moreover, the table (see p. 938) shows the frequent occurrence of tarsi with a supernumerary armature on more than one joint.

(d) *Malformed Tarsi.*

Among the several thousand tarsi examined there were found 10 in which one or more of the articulations were imperfectly formed. The appearance of such cases is sufficiently explained by Plate LVIII. figures 4–10, and they are probably much the same as the “crippled” limbs often found in Coleoptera and other groups. The present cases seem to be reproduced tarsi, though those illustrated by figs. 4 and 10 are perhaps malformed

“normal” tarsi. The interest of these crippled tarsi lies in their great rarity, their tendency to possess several supernumerary spines, and the fact that the fusions resulting from the incompleteness of the articulations are nearly always confined to the intermediate shorter joints, leaving the proximal and distal joints well-defined.

THE CHARACTERS OF REPRODUCED APPENDAGES IN OTHER
INSECTA AND ARTHROPODA GENERALLY.

Before making a comparison of the normal and reproduced legs of the Blattidæ from a statistical point of view, it is desirable to refer to certain special characters possessed by reproduced appendages in other groups of Arthropods.

The observations of various authors on reproduction of lost appendages in Arthropoda have usually been of but partial nature, and only in a few cases have experiments in this connection been extended over a large number of individuals of the same species.

But the published work is sufficient to indicate that the structures which replace lost or mutilated appendages fall into two main divisions. Moreover, one or the other of these two kinds of reproduction is constantly associated with a particular degree of injury in particular cases of appendages or genera to the entire exclusion of the other kind. In other words, a certain injury to a particular appendage among particular families of genera is invariably followed by reproduction of one kind. The other kind of reproduction is as constantly associated with other cases. The two kinds of reproduction met with are briefly:—

(a) *In all chief respects, such as the number of joints and their relative dimensions, the reproduced appendage is the counterpart of the normal congenital appendage.*

(b) *The reproduced appendage differs from the normal appendage in certain respects which are constant, and in cases where maturity of the animal is attained through a series of ecdyses the special features of the reproduced appendage are perpetuated; so that, strictly speaking, the animal does not reproduce the normal appendage. The chief distinguishing feature of this kind of reproduction is that the number of joints present is less than in the normal appendage.*

THE FOLLOWING CASES FALL UNDER (a):—

CEUSTACEA. *Decapoda*.—Observations on the reproduction of lost appendages appear to have been mainly on the Decapoda. The accounts of authors already referred to agree in stating that the *chelæ* and *walking-legs* are reproduced by structures resembling the normal in all respects except size. As regards the flagellum of the *antenna*, it is, however, not possible to speak with certainty, for no observer has given any details as to the number of its joints when reproduced. Moreover, the large number of joints of the normal antenna in most cases and the liability to loss of the more distal joints leave the normal numbers for most species somewhat

uncertain. But some degree of circumstantial evidence that the reproduced flagellum has the normal number is afforded by observations (18, 68) that it is very often of equal length with its fellow at the first ecdysis after mutilation.

But that the reproduced appendages of Crustaceans are not invariably replicas of the normal is shown by the experiments of Przibram (67) and by the remarkable cases described by Herbst (48), Hofer (50), and Milne-Edwards (60) of various Decapods replacing an eye by an antenna-like structure. These instances, however, do not fall under (b) above, and for the present must stand apart as isolated cases with special features. Borradaile (11) has recently described certain instances of abnormal *antennæ* in *Macrura-Anomala* which may possibly have arisen in connection with reproduction, but these also differ from the cases to be described under (b) in the possession of *more* than the normal number of joints.

Isopoda.—Heineken (47) made a few observations on the reproduction of the *antennæ* of a Madeiran *Armadillo*; but his account unfortunately gives no details beyond stating that the new growths were sometimes "perfect" and sometimes "rudimentary."

Cirripedia.—Darwin (22) speaks of the regeneration after injury of the *cirri* (*thoracic limbs*) in *Balanus* as though the new structures were like the normal.

ARACHNIDA. *Araneidæ*.—The *pedipalps*, *walking-legs*, and *spinnerets* appear, when reproduced, to be invariably like the normal in all respects except size. Blackwall, however, mentions that if the pedipalp of a male Spider is mutilated between the penultimate and final ecdyses, the sperm-case of the digital (terminal) joint is not developed on the attainment of maturity. This structure, which is distinctive of the adult condition, is produced in cases where mutilation is performed *two* ecdyses before maturity.

MYRIAPODA.—Newport's observations (61) indicate that the *walking-legs*, when regenerated, though of small size, are of normal structure.

INSECTA. *Orthoptera-Saltatoria*.—It appears, from the recent investigations of Griffini (*loc. cit.*), that in this group reproduced legs possess the normal number of joints throughout.

Neuroptera.—Watson (77) found that injury to the *leg* of an *Agrion* larva resulted in the production of a limb of normal aspect at the next ecdysis, except that the claw of the terminal tarsal joint was absent.

UNDER (b) MAY BE PLACED THE FOLLOWING OBSERVATIONS :—

ARACHNIDA. *Scorpionidæ*.—The cases of regeneration referred to above as shown to me by Mr. R. I. Pocock were a *Buthus* and a *Scorpio*, both immature. In the former the *leg* had been broken very near the base of the femur, and from this point there grew out a dwarf tarsus with terminal claws of normal appearance. In the latter case a break had occurred in the patella, and borne apparently directly on the seat of injury were a set of small but

normally shaped claws. Mr. Pocock informs me that he has noticed other cases of a similar nature. The production of the normal *terminal* structure, associated with deficiency of proximal parts, as in the above cases, is one of the chief characters of the kind of regeneration defined under (b).

MYRIAPODA.—Newport (61) removed the normal 7-jointed *antenna* of *Julus* by cutting through j_2 close to its base, but without apparently injuring j_1 . At ecdysis a dwarf 6-jointed antenna appeared, each joint being shorter and thicker than the normal, while J_6 closely resembled j_7 . [But section of j_3 resulted at ecdysis in the production of an antenna having 7 joints, an instance of regeneration of the kind described under (a), which is cited in this place for the sake of comparison.]

INSECTA. *Collembola*.—Lubbock (55) amputated the normal 6-jointed *antenna* of *Orchesella* by cutting through j_2 . At ecdysis the antenna was reproduced in a 3-jointed form, which was perpetuated through all subsequent ecdyses observed. J_2 was longer than j_2 , while J_3 was slender and resembled j_6 . In *Tomocerus* the result of pulling out j_4 of the normal 4-jointed antenna was the production and perpetuation of a 3-jointed antenna with J_3 like j_4 . Lubbock's own observations on *Aetheocerus*, and those of de Geer (34), Latreille (53), and Bourlet (14) quoted by him, all tend to show that fewer joints than the normal combined with a resemblance of the actual distal joint to the normal distal joint is the characteristic condition of an antenna when reproduced.

Orthoptera-Saltatoria. Acridiidae.—Griffini (42) describes a *Gomphocerus* in which the *antennae* had almost certainly been reproduced. In this genus the antenna has normally about 23 joints, the 7 terminal joints being clavate. The case described had 9 joints in one antenna and 2 in the other clearly defined, but in each case the terminal joint showed faint constrictions suggestive of incomplete division into from 3 to 5 joints. These terminal joints or series of fused joints were clavate, and so bore a resemblance to the terminal joints of the normal antenna.

Orthoptera-Cursoria. Phasmidae.—In this family the *legs* bear tarsi which are 5-jointed as in Blattidæ, and as in the latter there is ample evidence that when reproduced the tarsus assumes a 4-jointed arrangement. The probability that the latter condition arises in connection with reproduction was first pointed out by Coquerel (20). Previously to this the 4-jointed tarsus in Phasmids had perplexed several entomologists, especially on account of the asymmetry involved by the presence of one or two reproduced legs in otherwise normal individuals. Gray (41) had established the genus *Heteronemia* for specimens of *Bacteria mexicana* with "small hind legs." Westwood (80) had figured a *Cyphocrania* with reproduced tarsi, and devoted a new subgenus (*Craspedonia*) to cases of *Monandropoda inuncans* with 4-jointed tarsi on the anterior pair of legs. The error involved was corrected by Coquerel. Percheron (64) described an *Acanthoderus* and Newport (61) a *Lopaphus* with one or more tarsi 4-jointed.

Scudder (72) seems to have been the first to make experiments on the reproduction of the legs. In *Diapheromera* he found that amputation at any point below the femoro-trochanteric suture resulted in the reproduction of the lost parts with the tarsus in a 4-jointed condition. Bordage's experiments on *Monandroptera inuncans* and *Rhaphiderus scabrosus* show that the reproduced tarsus is invariably 4-jointed in these species. Through the kindness of Dr. David Sharp, I have been able to examine two nymphs of *Anchiale*, recently obtained in New Britain by Dr. A. Willey. Each of these has one leg reproduced with the tarsus 4-jointed. A third specimen is apparently in the same condition, though the tarsal articulations are not clearly defined. In the two former specimens, as in all the cases which have been figured or described in detail by the several authors above named, the terminal joint of the tarsus (J_4) resembles the terminal joint of the normal tarsus (j_5) and possesses the normal double claw. J_1 resembles j_1 , and J_2 and J_3 are like the intermediate joints of the normal tarsus. In view of this evidence it seems not improbable that Fortnum (25) overlooked the tarsus in the case of a *Diura* which he describes as having renewed one of the legs with "all the joints perfect."

Blattidæ.—My own previously published observations that experiment shows that the reproduced legs in this family bear 4-jointed tarsi may be added to the evidence from captured specimens collected by Brisout de Barneville (16), quoted in my previous paper. I have also noticed the 4-jointed tarsus in apparently reproduced legs in *Loboptera*. Newport mentions a *Panesthia* with one tarsus apparently in a 3-jointed condition, which was probably an instance like the "crippled" tarsi in *Stylopyga* described above.

Hemiptera-Heteropoda.—Douglas (23) has described an extensive series of unilateral abnormalities in antennæ which he considers were for the most part the results of reproduction after loss of the normal antennæ. His cases were collected from more than twenty species belonging to the sections Lygaeina, Coreina, and Scutatoria. The characteristic features of the apparently reproduced antennæ were that, whether the normal number of joints was 4 or 5, the abnormal antenna possessed one joint less than the normal, and that the actual terminal joint resembled the normal terminal one. As a rule these antennæ had the intermediate joints of different relative lengths from those of the normal, the most frequent variations being that J_2 was longer than j_2 and J_4 than j_5 . But there was a considerable want of uniformity in the conditions observed. In some cases the antennæ were apparently of normal structure with the terminal joint wanting, while in others with the normal number of joints he found partial fusions between two joints and abnormally short single joints. On the whole it seems probable that while most of the cases were reproductions having the general features described under (b), some of them were merely instances of injured normal antennæ.

Heineken (46) has a single case of the *antenna* of *Reduvius* being regenerated with 3 joints instead of the normal 4 after mutilation in the "pupal" state.

Lepidoptera.—Observations on the regeneration of appendages in this order have yielded results so varied that it is not possible to place them as a whole under either (a) or (b). It has already been pointed out that much more experimental observation, and a clearer understanding of the exact relations borne by the larval and pupal appendages to those of the imago, are necessary before the phenomena of reproduction in this order can be interpreted satisfactorily. The effects of mutilation of the legs of larvæ on those of the imago were first investigated by Réaumur (71), and since his time the subject has attracted only occasional notice. From the small amount of recorded work it is not possible to gather how far the results of a particular kind of injury at a particular stage in the life-history are uniform. The largest number of experiments on a single genus appear to be those of Newport (61) on *Vanessa* larvæ. In the imagos there was much variation in the condition of the injured limbs. In all cases femur, tibia, and tarsus could be distinguished, but the number of tarsal joints varied considerably. In all, however, the terminal claw of the tarsus was present. This fact and the drawings which illustrate his paper suggest that the reproduced tarsus in all these cases should be regarded as representing the whole of the normal tarsus, rather than for instance that a 3-jointed tarsus should be considered as equivalent to three particular joints of the normal tarsus. However this matter be looked upon, it remains that the tarsus is sufficiently represented to bear the normal termination, the claw: so that these observations on *Vanessa* are of particular interest as evidence of the tendency, so characteristic of the instances quoted under (b) above, towards the production of the terminal structure normal to the limb, so that though normality in the number of joints may be wanting, its actual termination is of normal structure. But this tendency is not displayed in *Lepidoptera* with the constancy it possesses in other orders, for the experiments of Mélièse (58) on *Sericaria* and of Watson (77) on *Dicranura* gave results contrary to Newport's as regards the tarsal claws. The total number of observations by these two authors was, however, too small for a fair comparison with those of Newport.

But setting aside the *Lepidoptera*, it seems that we have at least some clear indication that in other groups of *Arthropods* in which reproduction has been studied there are two well-defined types of structure assumed by the growths which replace lost appendages, and that in any given case these two kinds are not interchangeable. The reproduced limb either resembles the normal in the number and conformation of its joints, or else it does not do so. Now the interest of the cases in which the reproduced appendage differs from the normal is that the various examples exhibit a considerable degree of uniformity in their abnormal characters—a uniformity which is sufficiently marked to enable us

to say that just as appendages reproduced like the normal are true to a type, so those which differ from the normal are true to a type also, and are not merely irregular and unfinished imitations of the normal structures concerning which it is possible to say "this is the normal structure with such and such a part wanting or malformed." The features leading to the above conclusion are briefly as follows:—

The most prominent is that the number of joints is less than the normal. This numerical difference is, with certain rare exceptions, an actual one and not merely an apparent difference due to such a factor as the presence of incompletely formed articulations. The joints of the appendage are distinctly marked off from each other by articulations of apparently normal completeness. Another character is that in cases where the normal appendage possesses the terminal joint or joints differentiated from the others in length or form, the reproduction has its terminal joint or joints modified so as to in some cases apparently exactly, and in others to approximately resemble those of the normal.

A third character is that the special features are perpetuated through all stadia into maturity, no matter what instar suffered the loss necessitating reproduction. The evidence as to this is, however, not complete in all cases, but there is no record of numerical increase taking place in a reproduced appendage. That this is so is of interest in connection with the fact that in cases where the normal post-embryonic development is prolonged it is characteristic that the number of joints in at least the case of antennæ is progressively increased. At present the evidence suggests that the growth reproducing a lost appendage is without the power of numerical increase. If this is really so, it is necessary to ask whether we are justified in regarding the phenomena of reproduction as equivalent to a simple recurrence of normal development in at all events such cases as those under consideration. In the instance of the reproduced tail of Lizards we know that it is not. If the regeneration of a Tracheate limb is a process of budding, there is at least one difference between a congenital and a reproduced limb—viz., that the former arises as an outgrowth from the trunk, while the latter is a product of the basal part of the limb itself and so is not a regrowth of the entire limb. If, on the other hand, ecdysis involves reconstruction of the soft parts, the regeneration of a lost appendage must be brought about by changes more like those which usher in each successive stadium under normal circumstances.

It has been suggested from time to time that such departures from the normal as have been described above should be regarded as equivalent to normal appendages with one or more joints omitted, and sometimes it has been sought to identify particular joints of the normal as absent in the reproduced limb; but these suggestions have rested on the general appearance of the latter and not on statistical comparisons of the features of the normal and reproduced structures.

So far as the tarsus of the Blattidæ is concerned, reference to tables B and C, giving the ratios for the several joints of the 5-jointed and 4-jointed forms, seems to forbid such an explanation of the condition of the latter. This is evidently divided up in a manner peculiar to itself. A like conclusion follows a comparison of the actual length of the joints of two tarsi of the same total length and from the same pair of legs of one individual, when one is 4-jointed and the other 5-jointed. And with regard to other cases, a consideration of the descriptions and figures of the authors whose work I have quoted does not support the view that we can explain numerical deficiency on the ground that any *particular* joint of the normal appendage is absent in such and such an instance. The structure of the reproduced appendage being what it is, seems to render this kind of explanation meaningless, as Bateson (2) has already pointed out in commenting on the reproduced tarsus of *Periplaneta*. There is perhaps more to be said for the view put forward by some, that these abnormal reproduced structures contain the representatives of one or more joints of the normal limb fused together and that hence arises the numerical deficiency. But such an explanation demands that a certain joint of the reproduced limb should be equivalent in length to the sum of two or more joints of a normal limb of the same total length. But in the case of the tarsi of Blattidæ the measurements already quoted show that here at least such an explanation is inadmissible. It is true that the number of individual cases included in the tables was not large, but it may be held to have been large enough to demonstrate that it would be exceedingly exceptional for the sum of any two joints of the normal tarsus to even approximate the length of a single joint of the reproduced tarsus, for the measurements given contain no example of this kind. We may suppose that J_1 and J_4 correspond with j_1 and j_5 respectively on account of their structural characters and position, but there is nothing to establish that J_2 and J_3 represent either $(j_2 + j_3) + j_4$ or $j_2 + (j_3 + j_4)$ —a result which shakes confidence in the identification of the longer proximal and terminal joints with those of the normal. This matter also has been already discussed by Bateson in the place cited, and it is enough to add that his conclusion that the four joints of the reproduced tarsus collectively represent the five joints of the normal, which was based on measurements of *Periplaneta* only, is borne out by those of *Stylopyga* made more recently.

The view that such reproduced structures should be looked upon as intrinsically on a different plan from the normal structures they replace, rather than as abortive attempts at the exact reproduction of those normal structures, finds support not only on the grounds already set forth, but in some cases at least from the closeness of the variation of their individual parts. In the case of *Periplaneta americana* measurements of the lengths of the tarsal joints were made in 115 normal and 115 reproduced tarsi. These tarsi were all from the third pair of legs of adult individuals. The total length of each tarsus was reduced to 1.000 and the lengths of the

individual joints expressed correspondingly as fractions. The values so obtained were then arranged in ascending order in their own series, and those occupying the positions of the first, second, and third quarter divisions noted. Following the terminology of Galton (31) these are indicated by Q_1 , M , and Q_3 respectively. The probable error of variation of the series from its mean value will then be expressed by Galton's formula $\frac{Q_3 - Q_1}{2}$.

TABLE F.—*Periplaneta americana*.

Five-jointed tarsus.

	J_1 .	J_2 .	J_3 .	J_4 .	J_5 .
Q_1	·521	·152	·095	·046	·162
M	·529	·156	·099	·049	·168
Q_3	·535	·160	·101	·051	·174
Mean error as percentage of M }	1·3	2·6	3·0	5·0	3·6

Four-jointed tarsus.

	J_1 .	J_2 .	J_3 .	J_4 .
Q_1	·565	·178	·060	·172
M	·575	·183	·064	·177
Q_3	·584	·189	·068	·183
Mean error as percentage of M }	1·6	3·0	6·2	3·1

It will be seen that the percentage variation of the several joints is very little greater in the case of the reproduced than in that of the normal tarsi. Too much reliance should not be placed on the results obtained for the smaller joints, as in their case the errors of observation are necessarily greater proportionately. At the same time it is probable that we are justified in accepting the indication that these joints are in a somewhat less stable condition than the proximal and terminal joints, for the above result goes hand in hand with the facts elicited from a consideration of the cases of "malformed" tarsi already described.

Subsequently to the construction of the above table, which has already been published (2), with the kind assistance of Mr. Alfred Harker I tested the closeness of the correlation between certain of the joints by the method devised by Galton (32). This method deals with the relations between any two parts of a structure whose dimensions are capable of expression by numbers, and its

application to the present case reads as follows:—For every unit of absolute length that a particular tarsal joint deviates from the mean length of such joints in the series examined, any other joint selected will on the average deviate from the mean length of such joints to the extent of x units and in the same direction. [x would be equivalent to unity only in the hypothetical case of the two joints always varying exactly together, or, in other words, exhibiting an absolute correlation.]

TABLE G.—*Periplaneta americana*.

5-jointed tarsi.

The deviation of j_1 from its mean being 1·0,	the mean of the corresponding deviations of j_2 from its mean was	·52.
“ j_1 “ “	1·0, the mean of the corresponding deviations of j_5 from its mean was	·72.
“ j_2 “ “	1·0, the mean of the corresponding deviations of j_5 from its mean was	·31.

or, expressed conversely,

The deviation of j_2 from its mean being 1·0,	the mean of the corresponding deviations of j_1 from its mean was	·52.
“ j_5 “ “	1·0, the mean of the corresponding deviations of j_1 from its mean was	·72.
“ j_5 “ “	1·0, the mean of the corresponding deviations of j_2 from its mean was	·31.

4-jointed tarsi.

The deviation of J_1 from its mean being 1·0,	the mean of the corresponding deviations of J_2 from its mean was	·70.
“ J_1 “ “	1·0, the mean of the corresponding deviations of J_4 from its mean was	·66.
“ J_2 “ “	1·0, the mean of the corresponding deviations of J_4 from its mean was	·49.

or, expressed conversely,

The deviation of J_2 from its mean being 1·0,	the mean of the corresponding deviations of J_1 from its mean was	·70.
“ J_4 “ “	1·0, the mean of the corresponding deviations of J_1 from its mean was	·66.
“ J_4 “ “	1·0, the mean of the corresponding deviations of J_2 from its mean was	·49.

The number of cases on which the above results are based is of course much smaller than is usually adopted for the consideration of normal correlated structures on such lines, but it serves to show the similarity of behaviour of the two kinds of tarsi. The specially rapid growth of regenerated appendages has been referred to already, and the following observation on *Periplaneta* emphasizes the specialized nature of the regenerated limb by indicating that the rate of growth is controlled according to the age of the animal at the time of injury.

20 adults of *P. americana* were found with the third pair of legs bearing on one side a normal and on the other a 4-jointed tarsus. The percentage difference in total length of the tarsi of the two kinds averaged only 3·5, an amount not appreciable to the naked eye. Now it is not at all likely that in all these cases the repro-

duced tarsi had started in the same instar, so it is evident that their growth, always more rapid than that of the normal structures, must have been subject to a special trophic control whereby those which commenced their existence in the later instars grew more rapidly than those of earlier origin. In a series of *Stylopyga orientalis* there is, however, less evidence of such a special control, for there is usually a well-marked difference in size between a reproduced tarsus and its normal fellow in adult specimens as well as in young.

But this species affords an additional illustration of the specialized nature of the reproduced tarsus; for, as has already been shown in Table C, the several joints undergo changes in their relative proportions at the attainment of the animal's maturity in the same directions as do those of the normal.

It seems probable that a statistical examination of the reproduced legs of Phasmidæ would yield much the same results as above; but there is as yet not sufficient evidence to justify a statement that the reproduced antennæ of Myriapoda, Collembola, and Hemiptera have so high a degree of specialization. It is possible that there are intrinsic differences in the two kinds of appendages in their response to particular injuries. It has already been pointed out that injury to the basal joints of an antenna in some forms may result in numerical deficiency with its correlated peculiarities, while the removal of distal portions alone is followed by their regrowth with normal features.

In this connection it is of interest that the more basal antennal joints seem to be specially concerned in the formation of new articulations in certain forms which progressively increase the number of joints through the sequence of the ecdyses [Termitidæ (40), Ephemeridæ (54), Phasmidæ (73)]. And in the rare case of a diminution in the number of joints with advancing age described by Lubbock (54) as occurring in nymphs of *Chloëon*, it is the 4th joint of a 20-jointed antenna which amalgamates with itself the three joints distal to it.

But admitting that there is greater variability in reproduced antennæ, it is clear that when they differ from the normal they do so in the same kind of way as do the legs of Phasmidæ and Blattidæ, and with them form a series of instances standing in remarkable contrast with those in which the reproduced appendages are replicas of the normal. The causes which promote these differences of behaviour in allied groups are for the present quite obscure.

So also are we in the dark as to the factors which give constancy to a growth which arises sporadically and has not been represented in the normal ontogenetic development. It is surely therefore somewhat meaningless to apply to such cases terms like "throwing back" and "reversion," as has been done by certain authors. It is indeed true that reproduced parts in various animals display characters similar to the normal characters of corresponding parts in presumably allied genera. Perhaps the best known of such

instances is that afforded by the scaling of the reproduced tail in certain Lizards (12, 13). In a recent note Giard (36) has collected instances of this kind of variation under the title of "hypotypic regeneration," and has included thereunder the 4-jointed reproduced tarsus of Blattidæ and Phasmidæ. In the suggestion that such structures are really reversions to ancestral forms he is followed by Bordage (6).

Such a view must be based on the assumption that the normally 4-jointed tarsus of Lepismidæ and Locustidæ represents the primitive condition in Insecta, the grounds for which being that the Lepismidæ are usually held to be primitive forms and that the reproduced tarsus in Locustidæ does not exhibit any reduction in the number of its joints. But the tarsus of Insects as known to us is characteristically *five*-jointed, and our ignorance of the meaning of the phenomena known as reversions denies much weight to arguments supported by appeal to them.

Our present knowledge of the whole subject of reproduction after injury is so scanty as to render of very minor value such arguments as that "it is advantageous for a mutilated individual to abridge the process of reproduction and not to recapitulate in their entirety all the phylogenetically ancestral stages." Have we indeed any justification at all for supposing that reproduction of any part is a recapitulation of even the normal ontogeny? In the cases already described only one seems to afford any degree of suggestion that reproduction involves a throwing back of normal development, and that is the observation of Blackwall that male Spiders do not develop the adult sperm-case of the terminal joint of the pedipalp when that appendage has been mutilated between the penultimate and final ecdyses. But this peculiarly adult structure is not a distinct joint, and the instance is one in which a certain identifiable part of the normal appendage is absent, and so is unlike the instances in which the reproduced growth is a completely functional structure but differs from the normal in the arrangement of its parts generally.

It is of much interest in connection with the peculiarities of reproduction forming the subject of this paper, that departures from the normal in the main similar to them have been observed in genera the nature of whose developmental history, and the fact that the abnormal condition was frequently manifest symmetrically on the two sides, seem to render it most unlikely that reproduction had occurred. Cases of this kind in antennæ of certain Hymenoptera and Coleoptera have been commented on by Bateson (2. p. 411); and though in some of the examples the variation in the number of antennal joints was so great that the normal number remained uncertain, the following features occurred not infrequently. Where the terminal joint or joints were in the normal of specialized structure, the exceptional cases of few-jointed antennæ presented a similar condition. Moreover there were usually departures from the normal in the relative lengths of the other joints, and the joints were usually of longer individual lengths than those

of the normal. Garbowski (33) has more recently described a case in *Hygrocarabus* where a leg was similarly affected, and Bateson's series of examples from the antennæ of *Forficula* (2. p. 413) seem for the most part to belong to the same category. In this genus the number of antennal joints is usually 14, though specimens with only 13 or 12 joints are not infrequent. Bateson found that in 13- and 12-jointed examples j_3 was markedly and j_4 somewhat longer than the corresponding joints in 14-jointed examples. In the case of 18 antennæ from adults measured by myself, 12 had 14 joints, 3 had 13, and 3 had 12. In the 13- and 12-jointed specimens j_3 was of about the same length as in the 14-jointed specimens, but in 5 out of the 6 j_4 was distinctly longer than in 14-jointed specimens. Among the 6 cases of few-jointed antennæ the more distal joints were longer than the joints in the same positions in 14-jointed specimens in 3 instances, and of practically the same lengths in the other 3 instances. So that here again is manifest the tendency for the appendage with abnormally few joints to approximate the total length of the normal by increasing the lengths of its individual joints. As *Forficula* is an orthopterous insect it is of course quite possible that some of these cases of few-jointed antennæ arose in connection with reproduction. Bateson inclined to the belief that the symmetrical condition of many such cases indicated a congenital origin at least occasionally. But in the light of the evidence that in Blattidæ the mechanism of reproduction is able to bring about symmetry in size between a normal and a reproduced tarsus on the same pair of legs and between two reproduced tarsi on the same pair, it seems possible that a similar compensating control may exist over other cases of reproduction. In their general features these exceptional antennæ of *Forficula* approach the certainly reproduced antennæ of Myriapoda and Collembola on the one hand, and the abnormal and apparently congenital antennæ of certain Hymenoptera and Coleoptera on the other. But much more evidence regarding the reproduction of the antennæ in a series of selected forms must be forthcoming before we can say anything as to the relationships between these peculiar appearances when seen in genera with such different life-histories.

In cases where the departures from the normal structural arrangement are known to have arisen as reproductions, it is of course permissible to regard them as in some sense analogous with bud-variations in plants; and as in their case, so also in that of arthropod appendages, the idea has been advanced that the disturbances seen are the results of insufficient and unequal nutrition. Though no doubt the removal of an appendage does produce an unusual demand on the nutritive channels directed to it, it would appear that any failure to deal with the special circumstances of the case is expressed rather in the small size of the reproduced structure than in its morphological features. For it is characteristic of the Tracheate groups at least that if any new growth at all is revealed at the ecdysis succeeding injury, it is in a sense a complete appendage and not an amorphous bud. The mechanism

of reproduction executes the proper work however much or however little may be the amount of material placed at its disposal. The suggested factor of insufficient nutritive supply is moreover no explanation of why in some genera or groups of genera the new growth is constantly a true "reproduction" in that it exactly resembles the normal, while in other genera or groups of genera it as constantly assumes a form which is strikingly different from the normal. And granted that parts subject to loss have their reproduction ensured by a special adaptation of the nutritive and trophic supplies appropriated to them, there is no solution yet possible of why reproductions which are unlike the normal should exhibit a degree of fixity and trueness to type which in the case of normal congenital structures we are accustomed to regard as the outcome of selection.

In summary of what has been said it seems to be the case that:—

(i.) In Arthropoda generally the power of reproducing a lost or injured appendage is partial in so far that the basal portion of the appendage must be left to inaugurate the new growth, reproduction of the entire appendage by the trunk being not possible.

(ii.) The power of reproduction seems to be possessed concurrently with the ecdyses and to be relinquished when these no longer occur.

(iii.) In Crustacea the reproduced portion of an appendage can be observed growing out from the stump, being covered with a thin cuticle specially formed over it. In Tracheata the reproduced portion does not become revealed till ecdysis, being entirely hidden by the cuticle of the region proximal to the place of amputation. There is some evidence that in many cases the elaboration of the reproduced portion is a rapid process taking place only just before ecdysis.

(iv.) Subject to certain objections to regarding the reproduced appendage of a Tracheate Arthropod as invariably of the nature of a bud from the stump, in some forms reproduction may commence from almost any part of any joint, while in others autotomy or else the dropping away of portions of the stump subsequently to injury determines that reproduction shall commence only from very few regions or even only from a single region.

(v.) In Crustacea the reproduced portion of an appendage is, with reservations as to certain doubtful and exceptional cases, an exact counterpart of the congenital structures it replaces. This is also constantly the case with certain appendages in certain Tracheata.

(vi.) In certain appendages of some Tracheata the reproduced portion is constantly unlike the normal, being distinguished therefrom mainly as follows:—

- (a) The number of joints is less than those which have been lost, and is one less in cases where the normal number is not more than six.

- (b) The joints of the reproduced portion have relative dimensions which are different from those of the normal joints and render any scheme of identity therewith of doubtful value.
- (c) If the terminal joint or joints of the normal appendage are differentiated from those more proximal, then the terminal joint or joints of the reproduction are similarly differentiated in spite of their want of agreement in numerical sequence with the joints of the normal.

(vii.) The peculiar distinguishing features of reproductions unlike the normal are perpetuated through all subsequent ecdyses, the normal structure not being reassumed at any time.

(viii.) The reproduced portion of an appendage, whether it is of the type exactly resembling the normal or of the type which differs therefrom as above described, possesses the power of growing with special rapidity, so that, always smaller than its congenital fellow on its first appearance, it sooner or later attains a symmetrical size, provided that this is not prevented by the cessation of general growth.

(ix.) The structural characters of reproductions which are unlike the normal often possess a high degree of organic stability, and in some cases at least a degree which is quite comparable with that possessed by the characters of the congenital structure the reproduction takes the place of. To account for this high stability in a reproduced structure by the operation of selection seems impossible.

(x.) In the instance of such a reproduction afforded by the 4-jointed tarsus of Blattidæ, so established is the nature of the reproduced appendage, that when the animal possessing it attains maturity, the relative proportions of its joints undergo the same kind of change as that which is normal in the congenital form of tarsus. It is thus obvious that a reproduction of this kind may not only possess a structural stability comparable with that of the normal, but also be dominated by a trophic control so specialized that the changes proper to the several stadia are brought about in the reproduced just as they are in the congenital appendage, being unimpeded by the profound structural differences between the two.

I must express my thanks to Mr. Adam Sedgwick for placing at my disposal the facilities of the Zoological Laboratory at Cambridge for this work, and to Mr. W. Bateson, not only for the suggestion which incited the inquiry, but for kind advice and criticism during its progress.

References to Literature.

1. BATE, C. SPENCE.—“Report of the Committee appointed to explore the Marine Fauna and Flora of the South Coast of Devon and Cornwall.” No. 2. Brit. Assoc. Rep. 1868, p. 283.
2. BATESON, W.—‘Materials for the Study of Variation,’ 1894, pp. 63 & 415.

3. BLACKWALL, J.—“ Report on some recent Researches into the Structure, Functions, and Economy of the Araneidea made in Great Britain.” Brit. Assoc. Rep. 1845, p. 62.
4. BODIER.—“ Sur la Reproduction des Pattes des Crabes.” Observations sur la physique, etc., de Rozier, 1778, xi. p. 33.
5. BORDAGE, E.—“ Phénomènes d'Autotomie observés chez les Nymphes de *Monandroptera inuncans* et de *Rhaphiderus scabrosus*.” Comptes-rendus Acad. Sci. 1897, cxxiv. pp. 210 & 378.
6. BORDAGE, E.—“ Sur la Régénération tétramérique du Tarse des Phasmides.” Comptes-rendus Acad. Sci. 1897, cxxiv. p. 1536.
7. BORDAGE, E.—“ Régénérations chez les Phasmides après des sections artificielles et non autotomique.” Bull. Soc. Entom. de France : séance du 13 juillet, 1898.
8. BORDAGE, E.—“ Sur les localisations de Régénérations chez les Phasmides.” Comptes-rendus Soc. de Biologie : séance du 30 juillet, 1898.
9. BORDAGE, E.—“ Sur le mode probable de formation de la Soudure fémoro-trochantérique chez les Arthropodes.” Comptes-rendus Soc. de Biologie : séance du 30 juillet, 1898.
10. BORDAGE, E.—“ De l'influence de certaines conditions sur la régularité de la Régénération tétramérique chez les Phasmides.” Comptes-rendus Soc. de Biologie, octobre 1898.
11. BORRADAILE, L. A.—“ On some Crustaceans from the South Pacific : Part II. *Macrura Anomala*.” Proc. Zool. Soc. 1898, p. 457.
12. BOULENGER, G. A.—“ On the Scaling of the Reproduced Tail in Lizards.” Proc. Zool. Soc. 1888, p. 351.
13. BOULENGER, G. A.—“ On an Iguana with Reproduced Tail.” Proc. Zool. Soc. 1891, p. 466.
14. BOURLET, L'ABBÉ.—“ Mémoires sur les Podures.” Mém. de la Soc. Roy. des Sci. Lille, 1839 ; and Trans. de la Soc. d'Agricult. du Départm. du Nord : Douai, 1841-42.
15. BRINDLEY, H. H.—“ On the Regeneration of the Legs in the Blattidæ.” Proc. Zool. Soc. 1897, p. 903.
16. BRISOUT DE BARNEVILLE.—Ann. de la Soc. Entom. 1848, sér. 2, vi. Bulletin, p. xix.
17. BROOK, G.—“ Notes on the Reproduction of Lost Parts in the Lobster (*Homarus vulgaris*).” Proc. Roy. Phys. Soc. of Edinburgh, 1887, p. 370.
18. CHANTRAN, M.—“ Nouvelles Observations sur le Développement des Écrevisses.” Comptes-rendus Acad. Sci. 1871, lxxiii. p. 220.
19. CONTEJEAN, C.—“ Sur l'Autotomie chez la Sauterelle et le Lézard.” Comptes-rendus Acad. Sci. 1890, cxi. p. 611.
20. COQUEREL, C.—“ Orthoptères de Bourbon et de Madagascar.” Ann. Soc. Entom. de France, 1861, sér. 4, i. p. 495.
21. COUCH, J.—“ On the process of Exuviation and Growth in Crabs and Lobsters.” Trans. Cornwall Polytech. Soc., 1843.
22. DARWIN, C.—‘ Monograph of the Cirripedia,’ 1854, p. 158.

23. DOUGLAS, J. W.—“On some peculiarities in the Development of Hemiptera-Heteropoda.” *Ent. Month. Mag.* 1865, ii. p. 270; 1866, iii. p. 200; 1876, xiii. p. 188; 1895, xxxi. p. 144.
24. DURIEU, A.—“Notes sur quelques Orthoptères.” *Petites Nouv. Entomol.* 1876, no. 158.
25. FORNUM, —Trans. *Entom. Soc. London*, 1845-47, iv. p. 98.
26. FRÉDÉRICQ, L.—“Amputation des Pattes par mouvement réflexe chez le Crabe.” *Archiv. de Biologie*, 1882, iii. p. 235.
27. FRÉDÉRICQ, L.—“Sur l'Autotomie ou Mutilation par voie réflexe comme moyen de défense chez les Animaux.” *Archiv. de Zoologie Expérim.* 1883, sér. 2, i. p. 413.
28. FRÉDÉRICQ, L.—“L'Autotomie chez les Étoiles de Mer.” *Rev. Scientif.* 1887, sér. 3, xiv. p. 589.
29. FRÉDÉRICQ, L.—“Les Mutilations spontanées ou l'Autotomie.” *Rev. Scientif.* 1886, sér. 3, xii. p. 613.
30. FRÉDÉRICQ, L.—‘La lutte pour l'existence chez les Animaux marins,’ 1889. [“Autotomie chez les Insectes,” p. 258.]
31. GALTON, F.—‘Natural Inheritance,’ 1889, Chap. v.
32. GALTON, F.—“On Co-relations and their Measurements.” *Proc. Roy. Soc.* 1888-89, xlv. p. 137.
33. GARBOWSKI, T. H.—“Aberrations in the Structure of Appendages in the Coleoptera.” *The Entomologist*, April 1895, p. 125.
34. DE GEER, C.—*Act. Soc. Reg. Sci. Upsala*, 1740, p. 64.
35. GIARD, A.—“L'Autotomie dans la Série animale.” *Rev. Scientif.* 1887, sér. 3, xxxix. p. 629.
36. GIARD, A.—“Sur les Régénérations hypotypiques.” *Comptes-rendus Soc. de Biologie*, 1897, sér. 10, iv. p. 315.
37. GONIN, J.—“Recherches sur la Métamorphose des Lépidoptères.” *Bulletin de la Soc. Vaudoise des Sci. Naturelles*, 1894, sér. 3, xxx. p. 122.
38. GOODSIR, H. D. S.—“A short Account of the mode of Reproduction of Lost Parts in the Crustacea.” *Ann. & Mag. Nat. Hist.* 1844, ser. 1, xiii. p. 67, and *Brit. Assoc. Rep.* 1844.
39. GRABER, V.—“Zur Entwicklungsgeschichte und Reproductionsfähigkeit der Orthopteren.” *Sitzungsb. der k. Akad. der Wiss. Wien, Math.-naturw. Cl. lv. Bd. i.* 1867; and *Ann. & Mag. Nat. Hist.* ser. 3, xix. p. 147.
40. GRASSI, B., & SANDIAS, A.—“Costituzione e Sviluppo della Società dei Termitidi.” *Catania*, 1893, p. 25; and *Quart. Journ. Microsc. Science*, 1896, xxxix: part 3, p. 245.
41. GRAY, G. R.—‘Synopsis of the Phasmidæ in the British Museum,’ p. 19.
42. GRIFFINI, A.—“Di un *Pristes tuberosus* anomalo.” *Boll. dei Musei di Zool. ed Anat. comp. Torino*, 1896, xi. no. 234.
43. GRIFFINI, A.—“Di due *Acrididi* anomali.” *Boll. dei Musei di Zool. ed Anat. comp. Torino*, 1896, xi. no. 256.
44. GRIFFINI, A.—“Descrizione d'una nuova Pseudofillide del Però e osservazioni sopra una anomalia del tipo di questa

- specie." Boll. dei Musei di Zool. ed. Anat. Comp. Torino, 1898, xiii. no. 328.
45. HALLEZ, P.—"Un mot d'historique à propos de l'Amputation réflexe des Pattes chez les Crustacés." Bulletin Sci. du Nord, 1886, sér. 2, xvii. p. 342.
 46. HEINEKEN, C.—"On the Reproduction of Members in Spiders and Insects." Zool. Journ. 1829, iv. p. 284.
 47. HEINEKEN, C.—"Experiments and Observations on the Casting-off and Reproduction of the Legs in Crabs and Spiders." Zool. Journ. 1829, iv. p. 422.
 48. HERBST, C.—"Über die Regeneration von antennenähnlichen Organen an Stelle von Augen." Archiv f. Entwicklungsmechanik, 1895, ii. p. 544.
 49. D'HERCULAIS, KÜNCKEL.—'Recherches sur l'Organisation et le Développement des Volucelles,' 1875, p. 160.
 50. HOFER, B.—"Ein Krebs mit einer Extremität statt eines Stielauges." Verhandl. d. deutschen zool. Gesellschaft, 1894, p. 82.
 51. HOWES, G. B.—"On the Reproduction of the 'Feeler' of the Lobster's Antenna." Journ. Anat. & Physiol. 1882, xvi. p. 47.
 52. HUXLEY, T. H.—'The Crayfish,' 1881, p. 38.
 53. LATREILLE.—"Organisation extérieure et comparée des Insectes de l'Ordre des Thysanoures." Nouv. Ann. du Muséum d'Hist. Nat. 1832, i. p. 186.
 54. LUBBOCK, J.—"On the Development of *Chloëon* (*Ephemera dimidiatum*." Trans. Linn. Soc. 1864, p. 61, and 1866, p. 477.
 55. LUBBOCK, J.—'Monograph of the Collembola and Thysanura,' 1873, p. 60.
 56. MACCULLOCH.—"On the means by which Crabs throw off their Claws." Quart. Journ. of Science, Literature, and Arts of the Royal Instit. 1826, xx. p. 1.
 57. MCCOOK, H. C.—Proc. Acad. Nat. Sci. of Philadelphia, 1883, p. 196; and Journ. Roy. Microsc. Soc. ser. 2, iv. p. 225.
 58. MÉLISE.—Ann. de la Soc. Entomol. de Belgique, 1879, xxii., Comptes-rendus, p. xcii; and Proc. Entomol. Soc. London, 1879, p. xxxii.
 59. MILNE-EDWARDS, H.—'Leçons sur la Physiologie et l'Anatomie comparée de l'Homme et des Animaux,' 1863, viii. p. 299 *et seq.*
 60. MILNE-EDWARDS, H.—"Sur un cas de Transformation du Pédoncule oculaire en une Antenne, observé chez une Langouste." Comptes-rendus Acad. Sci. 1864, lix. p. 710.
 61. NEWPORT, G.—"On the Reproduction of Lost Parts in Myriapoda and Insecta." Phil. Trans. 1844.
 62. NEWPORT, G.—"On the Reproduction of Lost Parts in the Articulata." Mag. of Nat. Hist. 1847, ser. 1, xix. p. 145.
 63. PARIZE, P.—"L'Amputation réflexe des Pattes des Crustacés." Rev. Scientif. 1886, sér. 3, xi. p. 379.



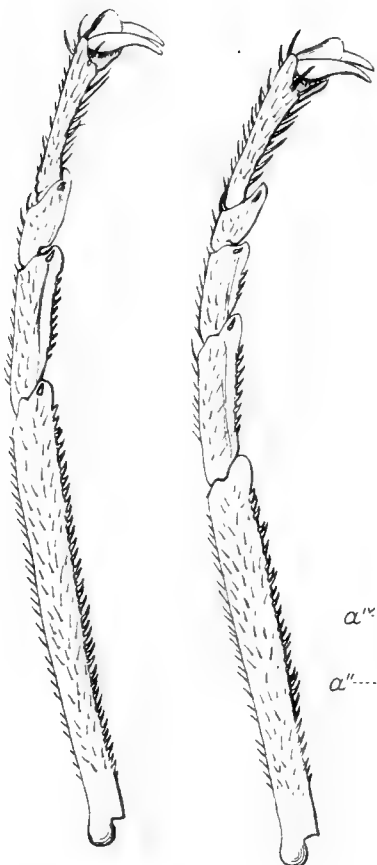

Fig. 3.

Fig. 2.

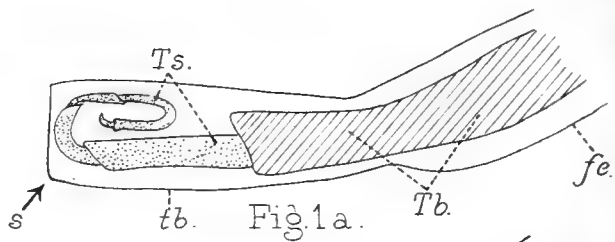

Fig. 1a.

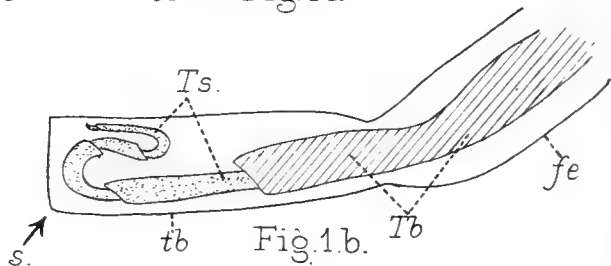

Fig. 1b.

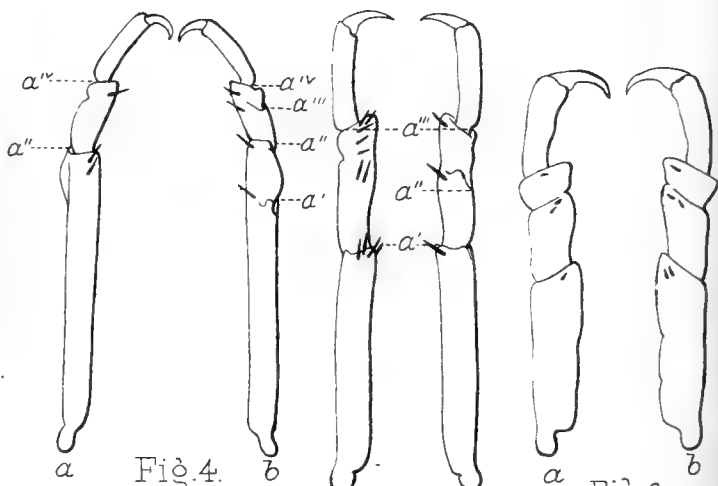

Fig. 4.

Fig. 5.

Fig. 6.

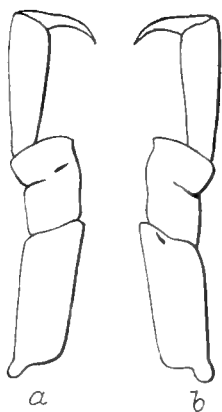

Fig. 7.

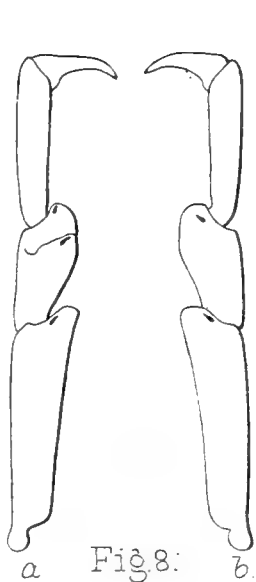

Fig. 8.

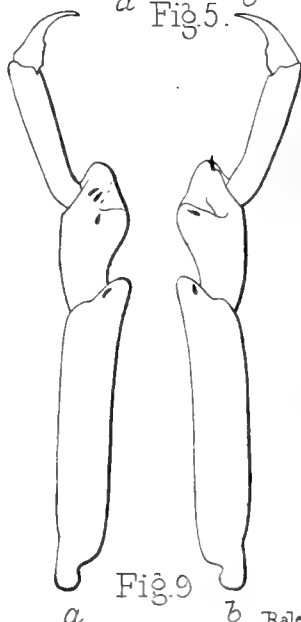

Fig. 9.



Fig. 10.

Bale & Danielsson, Ltd. Sculp.

64. PERCHERON, A., & GUÉRIN, E.—‘Genera des Insectes orthoptères,’ 1835–38, pl. 5.
65. DE PEYERIMHOFF, P.—“Note sur l’Atrophie des Membres chez les Orthoptères.” *Miscellanea Entomologica*, iv. no. 5.
66. POUCHET, G.—“Sur le sang des Crustacés.” *Journ. de l’Anatomie et de la Physiologie*, 1882, p. 203.
67. PRZIBRAM, H.—“Regeneration bei den niederen Crustaceen.” *Zool. Anz.* 1896, xix. p. 424.
68. PUTNAM, F. W.—“On some of the Habits of the Blind Crayfish (*Cambarus pellucidus*) and the Reproduction of Lost Parts.” *Proc. Boston Nat. Hist. Soc.* 1876, xviii. p. 16.
69. DE RÉAUMUR, M.—“Sur les diverses Reproductions qui se font dans les Écrevisses, les Omars, les Crabes, etc., et entr’autres sur celles de leur jambes et leurs écailles.” *Mém. de l’Acad. des Sciences*, 1712, p. 223.
70. DE RÉAUMUR, M.—“Observations sur la Mue des Écrevisses.” *Mém. de l’Acad. des Sciences*, 1718, p. 263.
71. DE RÉAUMUR, M.—‘Mémoires sur les Insectes,’ 1734, i. p. 365 & pl. 23.
72. SCUDDER, S. H.—*Proc. Boston Nat. Hist. Soc.* 1869, xii. p. 99.
73. SHARP, D.—“Account of the Phasmidæ, with notes on the Eggs,” in ‘*Zoological Results based on material from New Britain, New Guinea, etc.*,’ by Dr. A. Willey. Pt. i. 1898, p. 75.
74. DE VARIGNY, H.—“L’Amputation réflexe des Pattes chez les Crustacés.” *Rev. Sci.* 1886, sér. 3, xi. pp. 308, 379, & 701.
75. WAGNER, W.—“Régénération des Organes perdus chez les Araignées.” *Bull. de la Soc. Imp. des Naturalistes de Moscou*, 1887, no. 4.
76. WAGNER, W.—“La Mue des Araignées.” *Ann. des Sci. Nat. sér. 7 (Zoologie)*, vi. 1888, p. 281.
77. WATSON, J.—“On the Re-development of Lost Limbs in the Insecta.” *The Entomologist*, 1891, xxiv. p. 108.
78. WEISMANN, A.—“Die nachembryonale Entwicklung der Musciden nach Beobachtungen an *Musca vomitoria* und *Sarcophaga carnaria*.” *Zeitschr. wiss. Zoologie*, 1864, xiv. p. 187.
79. WERNER, F.—“Selbstverstümmelung bei Heuschrecken.” *Zool. Anzeiger*, 1892, Jahrg. xv. p. 58.
80. WESTWOOD, J. O.—‘*Catalogue of Orthopterous Insects in the British Museum. I. Phasmidæ*,’ 1859.

EXPLANATION OF PLATE LVIII.

Tarsi of *Blattidæ*.

- Figs. 1 a, 1 b. *Stylopyga orientalis*, p. 931. Dissections of stump of tibia and femur shortly before ecdysis. *s*, extremity of tibia after amputation of distal portion. *tb*, cuticle of tibia. *fe*, cuticle of femur. *Ts*, new tarsus. *Tb*, new tibia. [Diagrammatic.]
- Fig. 2. *Periplaneta americana*, p. 935. 5-jointed congenital form of tarsus (from third pair of legs). × 8.

- Fig. 3. *Periplaneta americana*, p. 935. 4-jointed reproduction form of tarsus (from third pair of legs). $\times 8$.
4. *Stylopyga orientalis*, p. 939. Malformed tarsus, 3rd pair, nymph. a^i , a^{iii} , incomplete articulations; a^{ii} , a^{iv} , complete articulations.
5. " " Malformed tarsus, 3rd pair, nymph. a^i , a^{iii} , complete articulations; a^{ii} , incomplete articulation.
6. " " Malformed tarsus, 3rd pair, ♀ adult.
7. " " Malformed tarsus, 1st pair, nymph.
8. " " Malformed tarsus, 1st pair, ♂ adult.
9. " " Malformed tarsus, 2nd pair, ♀ adult.
10. " " Malformed tarsus, 2nd pair, nymph.
- [Figs. 4 to 10 are not to uniform scale.]

2. Contributions to the Osteology of Birds.

Part II. *Impennes*¹. By W. P. PYCRAFT, A.L.S.

[Received October 24, 1898.]

(Plates LIX.—LXI.)

CONTENTS.

- i. Introductory Remarks, p. 958.
- ii. The Skull of the Adult, p. 959.
- iii. The Skull of the Nestling, p. 967.
- iv. The Vertebral Column, p. 976.
- v. The Pectoral Girdle and Sternum, p. 977.
- vi. The Pelvic Girdle, p. 978.
- vii. The Pectoral Limb, p. 979.
- viii. The Pelvic Limb, p. 980.
- ix. Summary, p. 981.
- x. Key to the Osteology of the *Impennes*, p. 982.
- xi. List of the principal Works referred to and consulted, p. 987.

i. INTRODUCTORY REMARKS.

The *Impennes* represent one of the most sharply defined groups to be found amongst the Carinatae. The skeleton presents many features which are quite unique. This is particularly the case with regard to the shoulder-girdle and pectoral limb, which have become considerably modified in adaptation to new functions—the use of the fore limb as a paddle instead of as an instrument of flight. The pectoral limb, shoulder and pelvic girdles have departed furthest from the typical Avian form; they represent the high-water mark of skeletal specialization which has been attained by the group, whilst the skull, pes, and thoracic vertebrae represent the least specialized and most primitive portions of the skeleton; but they do not furnish us with any facts of very great importance, they do not carry us beyond the confines of the Class. Osteologically the Penguins seem to be most nearly related to the Tubinares and Pygopodes, and, as Dr. Gadow and others have shown, the evidence of the soft parts confirms this supposition.

¹ For Part I., see P. Z. S. 1898, p. 82.

So much is known already about the osteology of the Penguins, thanks to the admirable memoirs of Watson (18) and Menzbier (13), that it will not be necessary to describe the bones in any great detail; rather, it will be the aim of the present paper to serve as a supplement to those just mentioned.

ii. THE SKULL OF THE ADULT.

The skull of the Impennes presents many points in common both with the Pygopodes and the Tubinares, but it can nevertheless be readily distinguished from that of both of these groups.

The Occipital Region.—The occipital condyle is sessile, and scarcely projects beyond the rim of the foramen magnum. In *Aptenodytes* there is a slight tendency towards a pedunculate condition. The general form of the condyle is reniform: in young specimens traces of the notochord are found in the shape of a small median dimple.

The foramen magnum is almost circular, but varies slightly in outline. The plane of the foramen slopes obliquely backwards. Its superior boundary forms the free edge of a well-rounded concavo-convex supra-occipital—the convexity outwards—which forms the characteristic “cerebellar dome.” On either side of this dome lie two bony “wings” or plates which present two distinct types of arrangement. These plates are formed, in part by the squamosal, and in part by the parietal bones (see page 968).

In *Catarrhactes*, the first of the two types, these plates arise from the squamosal prominence and run upwards to terminate on the lateral region of the cerebral dome, and are thus separated one from another by nearly the whole width of the skull.

Spheniscus forms the second type. Arising in the same region as the above, these plates have become thrust back, as it were, from the cerebral on to the cerebellar dome, thus placing a wide, deep, space between them and the cerebral dome. This space represents the posterior portion of the temporal fossa, which lodges the temporal muscle. The plate is continued upwards to the vertex of the skull, where, as in *S. magellanicus*, it joins a median sagittal crest bridging the space from the cerebral backwards to the cerebellar dome.

All the genera but *Spheniscus* belong to the first type. In *C. chrysocome* the cerebellar dome is rather more sharply defined than in any other members of the genus. In *C. chrysocome* and *C. chrysolophus*, seen in profile, its dorsal moiety appears slightly depressed; it passes, on either side, almost insensibly into the cerebral dome. In *C. schlegeli* and *Megadyptes antipodum* the cerebellar arises almost abruptly from the cerebral dome, and its greatest curve is in the centre of the median line, projecting appreciably beyond the level of the foramen magnum. The squamoso-parietal wings of *C. chrysocome* and *C. chrysolophus* are hardly to be distinguished; their greatest lateral expansion does not exceed .2 in. and the intervening fossa is narrow; in *C. schlegeli*,

the lateral expansion of the wing is $\cdot 3$ in. and the fossa is wider than that in the two preceding forms. In *Megadyptes antipodum* this region of the fossa is both deep and wide, and the squamoso-parietal wings are well developed, making this region of the skull closely resemble that of *Eudypptula* (Pl. LX. fig. 5).

Pygoscelis resembles *Catarrhactes* in the formation of this region of the skull. In the shape of the cerebellar dome, in its greater width and curvature in profile, it approaches *C. schlegeli*. The squamoso-parietal wings are but feebly developed, being represented only by a low ridge. *P. adelice* differs from *P. papua* in the outline of the cerebellar dome, inasmuch as in the latter the curve continually increases till it ceases at the foramen magnum.

In *Aptenodytes* the squamoso-parietal wings are more feebly developed even than in *Pygoscelis*. In *A. forsteri* they scarcely extend halfway to the lambdoidal ridge.

Eudypptula, in the form of the cerebellar dome, is somewhat intermediate between *C. chrysocome* and *C. chrysolophus*. In the development of the squamoso-parietal wings, and the width of the fossa posteriorly, it surpasses both. Though the vertical height in both genera is relatively the same, in *Eudypptula* the wings are further removed from the cerebral dome; in *E. minor* they are bent forward superiorly so as to join this almost at a right angle. In *E. albosignata* they run up to join the supra-occipital or lambdoidal ridge—which lies, really, halfway between the suture of that name and the coronal suture—where they remain separated by some $\cdot 6$ in.

Spheniscus demersus differs from *S. magellanicus* in that the temporal fossa, posteriorly, does not actually reach the vertex of the skull: the squamoso-parietal wings are continued from the top of the fossa forwards as a narrow and low ridge, eventually joining a median sagittal crest running forwards on to the cerebral dome. In *S. magellanicus* this region of the fossa runs upwards to the vertex, terminating at the sagittal ridge, being accompanied throughout by the squamoso-parietal wings.

In all the genera the exoccipitals are produced downwards, on either side, into a short, blunt, paroccipital process. The free edge of this, in *Catarrhactes*, is longer than that of the squamosal prominence; in *Pygoscelis* these relations are reversed. In *Aptenodytes*, *Eudypptula*, and *Spheniscus* these processes are subequal. The paroccipital processes form the outer walls of a large *pneumatic* cavity lying between the proötic and exoccipital, which opens into the mouth of the tympanic cavity.

In the skull of the nestling *Spheniscus* the form and position of the squamoso-parietal wings closely resemble those of *Catarrhactes*. The posterior region of the temporal fossa, so remarkable for its depth and width in the adult, is in the young bird very shallow and widely separated from its fellow of the opposite side.

The Roof of the Skull.—This is formed by the frontal and parietal bones. The posterior region of the cranium, in all the *Sphenisci*,

is crossed transversely by a ridge of bone. In *Catarrhactes*, *Pygoscelis*, *Aptenodytes*, and *Eudyptula* this ridge traverses the region of the lambdoidal suture, and may be called the lambdoidal ridge. In the adult it forms a line roughly dividing the cerebellar from the cerebral dome. In *Spheniscus* the ridge traverses the region of the coronal suture, and may be called the coronal ridge. In young birds both a lambdoidal and a coronal ridge exist together for a short time; later, by the deepening of the temporal fossa posteriorly, the latter becomes the free edge of the squamoso-parietal wing.

The *supra-orbital region* of the cranial roof presents some important modifications. In all, the frontal is more or less deeply grooved for the nasal gland, the groove running the whole length of the frontal from the parietal forwards to the level of the posterior border of the nasal, and it is with the form and development of this that we have now to deal. In *Aptenodytes* (Pl. LIX. fig. 3) the free edge of this groove is reflected up and runs forwards as a narrow tapering supra-orbital ledge for the whole length of the groove. In *Eudyptula* (Pl. LIX. fig. 4) and *Spheniscus magellanicus* (Pl. LIX. fig. 1) this ledge disappears almost immediately after its origin. In *Spheniscus demersus* the ledge takes the form of a very broad lateral expansion abruptly truncated in front, in the region of the posterior third of the groove. In *Catarrhactes* (Pl. LIX. fig. 5) and *Pygoscelis* (Pl. LIX. fig. 2) this ledge has greatly increased in width, and runs forwards to within a short distance of the lachrymal: moreover, its free edge has become flattened dorsally into a very distinct rim. This reaches its greatest development in *Pygoscelis papua* (Pl. LIX. fig. 2). In all, the supra-orbital groove is more or less completely walled in by a ridge of bone posteriorly. In *P. adeliae* this wall is absent.

The *interorbital region* of the frontal varies in width, from a broad median strip of bone in *Aptenodytes* to a sharp ridge in *P. adeliae*.

The outline of the supra-orbital ledge is continued forwards by the lachrymal. In *Catarrhactes chrysocome* (Pl. LIX. fig. 5) and *Pygoscelis taniata* this latter is largely visible in a dorsal view. Less of it is seen in *C. chrysolophus*, *Aptenodytes*, *Eudyptula*, and *Pygoscelis papua* (Pl. LIX. fig. 2). It is largely visible in *P. adeliae*, and has quite disappeared beneath the nasal in *Spheniscus*.

The posterior ends of the nasals are not distinguishable in the adult Penguin. The extreme posterior ends of the nasal process of the premaxilla can apparently always be made out lying between the nasals, except in very old specimens of *Spheniscus demersus*, where they are indistinguishable. In *Aptenodytes* and *Pygoscelis* the two prongs of this region of the premaxilla remain distinct one from another and from the nasals throughout life (Pl. LIX. figs. 2 & 3).

The Basioccipital Region.—When seen from below, this is bounded in the adult, on all sides, by a raised bony wall. Behind lies the occipital condyle, laterad of this a pair of mammillary processes, furnished by the exoccipitals, and immediately in front of these

lie two bony ridges converging in the middle line to meet over the parasphenoidal rostrum. In all but *Spheniscus* there is a more or less well-marked precondylar fossa. The two bony ridges (right and left) along the anterior border of this region represent what, earlier in life, formed the free edge of the basitemporal plate of the parasphenoid (p. 970). From the alisphenoid wings of the parasphenoid there has grown downwards a thin plate of bone to fuse with the sometime free edge just referred to. Thus the Eustachian grooves become converted into tubes. On breaking away the wall of this tube, a second smaller tube is found immediately above it. This also is formed in the parasphenoid and lodges the internal carotid artery, on its way to pass into the pituitary fossa. The larger, outer tube opens immediately behind the quadrate and forms the external auditory meatus.

Each mammillary tubercle is separated from the paroccipital process lying behind, and without, by a wide groove, at the bottom of which lie the foramina for the vagus and condyloid nerves.

The *parasphenoidal rostrum* takes the form of a slender curved rod, supporting the presphenoid and mesethmoid, and terminates at a point corresponding with a section through the skull at the lacrymals. Remnants of the anterior and posterior basicranial fontanelles¹ not infrequently occur, the latter being more or less concealed by the basitemporal plate.

The Lateral Aspect of the Cranium (Pl. LX, figs. 1-3).—The *tympenic cavity* is a tubular opening lying behind the articular end of the quadrate; it is bounded behind by the paroccipital process, above by the squamosal prominence, and mesially by the proötic and occipital bones.

The *squamosal prominence* is formed by a lateral outgrowth of the base of the squamosal immediately above its articulation with the quadrate. It forms a sloping floor to the posterior region of the temporal fossa.

The *temporal fossa* can best be understood by a careful study of its form and size in *Catarrhactes* (Pls. LIX., LX, figs. 5 & 2) or *Pygoscelis* (Pl. LIX, fig. 2). In these it is represented by a shallow horseshoe-shaped fossa lying between the postorbital process and the squamoso-parietal wings already described (p. 968). Its outline is defined by a raised surface, representing the extreme limit of attachment of the temporalis muscle; from the postorbital process it sweeps upwards, backwards, and downwards to terminate on the squamosal prominence. The greater part of the fossa rests upon the convex wall of the cerebral dome; posteriorly, from the squamosal prominence to its vertex, it is much deepened. From the apex of its semicircular outline there runs a well-defined

¹ In my paper on the Osteology of the Steganopodes (15), in describing the skull of *Fregata*, I mistook this anterior basicranial fontanelle for the Eustachian aperture. The Eustachian tubes in this genus are represented by grooves formed by the free edge of the basitemporal plate. The "traces of the Eustachian tubes" in the skull of *Sula*, referred to in this paper, are, as in the case of *Fregata*, remnants of this embryonic fontanelle.

lambdoidal ridge across the top of the skull to join the apex of the fossa of the opposite side (Pl. LIX. fig. 5, *t.l.r.*). In *Spheniscus* the posterior region of the fossa becomes greatly deepened, and the squamoso-parietal wings appear as though they had been forced backwards on to the cerebellar dome, leaving a deep groove between the base of this and the cerebral dome (Pl. LIX. fig. 1). As already stated, the fossa of one side is separated from that of its fellow on the other by a median, dorsal, sagittal ridge. The lambdoidal ridge of *Catarrhactes* is represented here by the free edge of the huge squamoso-parietal wing: in addition, there exists a second ridge anterior to this—the coronal ridge already described (p. 961), which is connected with the lambdoidal by a median sagittal crest (Pl. LIX. fig. 5, *cor.r.*). These ridges serve for the attachment of the peripheral portion of the temporalis muscle. The squamosal and parietal bones only take part in the formation of the temporal fossæ. The posterior region of the temporal fossa is wider in *C. chrysolophus* than in *C. chrysocome*, that of *C. schlegeli* is wider still. In *Megadyptes antipodum* it reaches its maximum, being both wide and deep, and somewhat closely resembles that of *Eudyptula*. The squamoso-parietal wings on either side are well developed and curve gently backwards, the outline of the free edge corresponding with that of the curve of the cerebral dome.

In *Aptenodytes* this region of the fossa is exceedingly shallow. In *Eudyptula* it is intermediate between the typical *Catarrhactes* and *Spheniscus*; that of *E. albosignata* reaches the lambdoidal ridge, in *E. minor* it falls below this.

The trigeminal foramen lies near the base of the skull, slightly below the level and mesiad of the articular head of the quadrate. Immediately above this, to the inner side of the squamosal prominence, is a tubular recess lying between the proötic and alisphenoid bones, and leading eventually, in the dried skull, into the cranial cavity. This recess is apparently derived by an invagination or ingrowing of the alisphenoidal border of the mouth of a fenestra lying immediately above the trigeminal foramen, with which it may even be confluent, as in the case of a young, macerated skull. It is found also in the skulls of the Tubinares—in some of which it is of great size—and Steganopodes (15).

The orbit is overarched, behind and above, by the postorbital process and supra-orbital ledge. The latter has already been described (p. 961); the former is made up in part of a lateral expansion of the frontal, and in part by the alisphenoid, to which is added a separate element in the shape of a cartilaginous sphenotic. Later the whole fuses into an indistinguishable outstanding mass—the postorbital process (Pls. LX., LXI. figs. 2 & 3). The inner wall of the orbit is formed for the most part by the orbito-sphenoid, its hinder wall is formed by the alisphenoid. The interorbital septum divides it mesially from the chamber of the opposite side. The septum is formed by the presphenoid and

mesethmoid. It is perforated by an interorbital fenestra, the size of which varies with age. The optic foramen is bounded in front by a median bony bar from the presphenoid, in front of which lies the interorbital fenestra.

The *mesethmoid* is a median, vertical, bony plate, in the adult fused with the parasphenoid below and the nasals and frontals above, and merging posteriorly into the orbito-sphenoid. It is greatly thickened anteriorly, and expanded laterally along its dorsal aspect, the lateral expansions curving outwards and downwards to form the "antorbital plate," which encloses a space opening forwards into the lachrymo-nasal fossa. In *Aptenodytes* and *Eudiptula* only, the postero-superior angle of this antorbital plate is perforated for the olfactory nerve; in other cases it runs along inside and above this plate and does not perforate it. There are no turbinal ossifications.

Only in *Aptenodytes* does the upper jaw greatly exceed the cranium in length; for the rest, the length of the upper jaw, from its tip to the ends of the nasal processes, is about equal to the distance from the last point to the cerebellar prominence. In *Catarrhactes* it is stout and somewhat deflected; the nasal processes are more or less swollen, attaining their maximum thickness in *C. schlegeli*, and their minimum in *Megadyptes antipodum*, which closely approaches *Pygoscelis*. In *Pygoscelis* the nasal processes are more or less uniform in thickness throughout. In *P. papua* the upper jaw is about $\frac{1}{5}$ longer than the cranium; in *P. adeliae* it is much depressed in the middle region, giving the jaw the appearance of being broader across than it really is; its outline in dorsal profile is, from the tip backwards, convex rather than concave as is usual; the length of the whole jaw is somewhat less than that of the cranium. In *Eudiptula* the upper jaw is more slender in proportion to the cranium than in any other genus. In *Spheniscus* the nasal processes of the premaxilla are greatly swollen, and the space enclosed by the internal and external nasal processes tends to become filled up by bone, and an accumulation of bony matter may run forwards from this along the nasal process of the premaxilla, so as ultimately to considerably decrease the size of the external nares.

The *quadrato-jugal bar* in *Aptenodytes*, *Catarrhactes*, and *Pygoscelis* is characterized by a very strongly-marked downward curvature. Descending abruptly from the lachrymal, it straightens out near its middle to run backwards to the quadrate parallel with the long axis of the skull (Pl. LX. figs. 1-3). In *Spheniscus* the curve is comparatively slight, and in *Eudiptula* is barely visible.

The *vomer* is free, double, and blade-shaped. The two halves are fused slightly along the antero-ventral border. It articulates on either side with the anterior end of the palatine, which sends forward a bony spur for its increased support.

The *palatines*, anteriorly, form slender rods, running forwards beneath the maxillo-palatine processes to fuse with the premaxilla and maxilla, anteriorly to these processes. Posteriorly,

behind the vomer, the palatines expand into moderately broad plates; the posterior palatine border is more or less emarginate, but its exact outline varies.

The *pterygoids* are expanded distally into broad plates or laminae, the anterior border of which follows more or less the outline of the posterior margin of the articular end of the palatine. *C. chrysolophus* and *Eudypsula* appear to be exceptions to this rule. Concerning the early history of the pterygoid, see p. 973.

The *quadrate* has distinct otic and squamosal articular heads. The orbital process in *Catarrhactes*, *Eudypsula*, and *Spheniscus* projects from the main body as a somewhat upwardly-curved rod with a sharp superior border; that of *Pygoscelis* closely resembles these but is longer. In *Aptenodytes* it takes on a triangular form, with a thickened inferior border. At the base of the inferior border of the orbital process lies a small well-defined pterapophyseal facet for articulation with the pterygoid. There are two condyles for articulation with the mandible, and these are confluent. The inner has two articular surfaces—an internal lateral facing the median plane, and a ventral which is continued backwards on to the semicircular outer face, immediately above and in front of which lies the deep cup for the articulation of the quadrato-jugal bar.

The Mandible.—The two rami of the mandible are united by a very slender symphysis. There is a short angular and internal angular process. A dentary, angular, supra-angular, and coronoid can always be distinguished. In young birds there is a distinct splenial.

In *Catarrhactes* the posterior border of the dentary is divided into two limbs—a small superior, and a large inferior having a strongly pronounced sinuous border which articulates with the supra-angular, the depth of the jaw in the region of this articulation being very considerable. The deeply incised posterior border of the dentary and the oblique slightly notched border of the supra-angular enclose a lozenge-shaped vacuity which is more or less imperfectly closed from within by the splenial. A second, oval vacuity pierces the supra-angular near its posterior end. Viewed from the inner side, this is seen to lead into an oblong fossa formed by cutting away the superior border of the coronoid; this fossa leads anteriorly into the dental foramen. The mandible of *C. chrysome* can be distinguished from that of *C. chrysolophus* by the greater convexity of its dorsal border, both dentary and supra-angular having the dorsal border much arched.

In *Pygoscelis* the depth of the jaw in the region of the dentary suture is very much less than in *Catarrhactes*. The superior limb of the dentary suture is relatively longer, and the posterior runs directly backwards with a gentle downward curve. It entirely lacks the strong sinuous border of *Catarrhactes*. The posterior vacuity is largest in *P. antarctica*.

In *Aptenodytes* the jaw is long and slender. The dentary of

A. forsteri has a conspicuous downward curve, that of *A. patagonica* is nearly straight. The posterior dentary border resembles that of *Pygoscelis*. The inferior border of the supra-angular is gently curved, not notched as in *Pygoscelis*. The splenial is long and narrow, and does not close the vacuity left by the excavation of the dentary and supra-angular sutures. The coronoid in *A. patagonica* is short and truncate anteriorly; in *A. forsteri* it is very long and slender, running forwards as far as the middle of the anterior lateral vacuity.

In *Spheniscus* the jaw is deeper from the middle of the supra-angular to the posterior border of the angulare than in *Pygoscelis*, and the processus angulare is longer. The anterior lateral vacuity is completely closed by the splenial. The coronoid is triangular in form: its inferior border is closely applied to the supero-posterior border of the splenial.

Eudyptula, in the form of the lower jaw, closely resembles *Spheniscus*, but is more slender throughout, and the internal and posterior angular processes are short, rather resembling those of *Pygoscelis*. It can easily be distinguished from *Pygoscelis*, however, by its shorter coronoid.

The Hyoid.—The hyoid of the Penguins resembles that of the Tubinares much more closely than that of the Pygopodes. The basibranchial, seen from above, is more or less shield-shaped, and is produced anteriorly into a short blunt process, bent almost at right angles to the main axis, and posteriorly into a similar process, but in the same plane as the body of the bone. The anterior process supports a cartilaginous basihyal, the posterior supports the urohyal. The urohyal is entirely cartilaginous and rod-shaped. The ceratobranchials are separated one from another at the base by the median posterior process; each is about 3 times as long as the basibranchial; the epibranchial is about $\frac{1}{3}$ the length of the ceratobranchial, from which it is separated by a cartilaginous rod rather less than $\frac{1}{2}$ length of the epibranchial itself.

The Cranial Cavity.—The metencephalic fossa is well defined. Its floor is flattened, and continued backwards, rising gently meanwhile to the free edge of the occipital condyle. It rises gently at the sides. The vagus foramen pierces its posterior lateral margin, and to the inner side of this lie two small condyloid foramina for the xii. nerve. The internal auditory meatus lies immediately above the vagus foramen, in the body of the proötic. Anteriorly, the fossa rises somewhat abruptly and overhangs the pituitary fossa, forming the dorsum sellæ.

The cerebellar fossa is bounded by the supra-occipital and parietal behind and above, the pro- and epiotic laterally, and the dorsal rim of the foramen magnum behind. A low tentorial ridge cuts it off in front: ventrally it merges with the metencephalic fossa. The floccular fossa lying between the epi- and proötic is large and deep.

The mesencephalic fossa lies in the alisphenoid. The ventral portion of the tentorial ridge bounds it externally, the proötic and

lateral region of the dorsum sellæ may be said to define it posteriorly. Its outer wall is pierced by the trigeminal foramen.

The pituitary fossa is very deep; its floor is pierced by two foramina leading outwards above the Eustachian grooves, at the point where the inner free border of the basisphenoid and parasphenoid plates meet one another to form the Eustachian tube. The dorsum sellæ is a flattened plate of bone sloping obliquely forwards over the pituitary fossa, and terminating at the oculomotor foramen. The pre-pituitary ridge slopes gently forwards; anteriorly to this, in the middle line, is a small triangular optic platform. The pre-optic ridge terminates on either side somewhat above the level of the tentorial ridge. The anterior border of the optic foramen is completed by the presphenoid, the posterior border by the alisphenoid.

The cerebral lies in front of the cerebellar fossa, the cerebellum not being covered by the cerebrum. The tentorial rises slightly below the level of the pre-optic ridge, sweeps backwards to the level of the junction of the epi- and proötics, then almost vertically upwards to the middle line, to terminate in the roof of the skull above the region of the dorsum sellæ. From this point forwards it is continued as a sharply defined ridge losing itself in the extreme anterior region of the fossa.

iii. THE SKULL OF THE NESTLING.

The sutures of the skull, like those of Struthious birds, remain open for a very considerable time, being quite distinct in advanced nestlings. The Museum collection possesses two such skulls—one of *Catarrhactes chrysocome* about quarter-grown, and one of a half-grown *Pygoscelis papua* (Pl. LXI. figs. 1-3); and from these the following descriptions are taken.

The *occipital condyle* is almost entirely formed by the basi-occipital, only a small portion being contributed by the exoccipital; a deep pit in its centre in the dried skull represents the remains of the notochord.

The *supra-occipital*, seen from without, is a vertically elongated bone of a rounded oval in outline and tumid in shape. It constitutes the characteristic "cerebellar prominence." It is bounded above by the parietal, and laterally by the epiotic, from which, in very young skulls, it is separated in part, superiorly, by a wide chink, and in part, inferiorly, by a deep groove. Its inferior border forms the upper boundary of the foramen magnum. There are traces, in the earlier stages, of an originally paired condition, in the shape of a mesial cleft running from the superior border downwards for about $\frac{1}{3}$ of its length; it then bifurcates, the two limbs terminating almost immediately after: later, as seen in a young *Pygoscelis*, the median cleft closes up, leaving a horseshoe-shaped fenestra representing the bifurcation, which, in its turn, disappears leaving in the adult no trace. The deep inferior groove separating the supra-occipital from the epiotic has in some cases

been so imperfectly ossified as to release the supra-occipital entirely from the epiotic.

The *evoccipital* forms the infero-lateral border of the foramen magnum; from the point where it joins the supra-occipital it runs upwards and outwards under the epiotic: its supero-lateral external border is bounded in part by a large tract of cartilage forming the outer wall of the floccular fossa, and in part, below this tract, by the proötic. The ventrolateral border is ensheathed in cartilage and produced downwards to form the paroccipital process. Seen from within, it is found to be fused with the opisthotic, the boundary-line between the two bones being indicated only by a faint notch lying just in front of the condyloid foramen.

The lambdoidal suture does not quite correspond with the ridge of that name. This arises from the middle of the posterior border of the squamosal, and running upwards for a short distance along the posterior border of the parietal parts company with the margin, where it curves downwards over the epiotic and continues its curve transversely; ultimately to meet in the middle line a little short of halfway between the coronal and lambdoidal sutures.

The *parietals* have the form of oblong plates of bone running transversely across the skull (Pl. LXI. fig. 3). The frontal border is rounded off dorsally at the point where the two parietals meet in the middle line; the same region of the frontals is similarly deficient, hence a small diamond-shaped fronto-parietal fontanelle is formed. The alisphenoid border is very narrow in *Aptenodytes*, being encroached upon by the squamosal; in *Spheniscus* and *Catarrhactes* it is broad, rather more than $\frac{2}{3}$ the total width and incurved. In *Pygoscelis* it is of medium breadth—about $\frac{1}{2}$ the total width, and only slightly curved. The squamosal border in *Aptenodytes* is more than four times the extent of that of the alisphenoid border; in *Spheniscus* and *Catarrhactes* the squamosal and alisphenoid borders are of about equal length; in *Pygoscelis* the squamosal border is about twice that of the alisphenoid and perfectly straight. The supra-occipital border develops a strong out-standing ridge which runs downwards to the squamosal. This ridge leaves the free border of the parietal almost immediately after it passes over from the squamosal, and runs upwards, in the case of *Spheniscus*, to the level of the dorsal limit of the supra-occipital, but does not meet in the middle line. The development of this crest, at this stage, closely resembles the permanent condition of that of *Aptenodytes* and *Pygoscelis*, and, in a slightly lesser degree, that of *Catarrhactes* and *Eudyptula*, since in the adults of these latter the crest is more developed laterally. In the adult *Spheniscus* this parietal crest forms the large out-standing plate of bone—the squamoso-parietal wing—which runs upwards to join the narrow median sagittal crest. In this way the posterior portion of the deep “temporal fossa” is formed.

The *frontals* undergo marked change of form before reaching the adult condition. They form paired plates of considerable size extending forwards, under the nasals, as a pair of divaricating

processes as far as the level of the anterior border of the lachrymal ; and backwards, to a point corresponding with the level of a line drawn through the articulation of the quadrate with the squamosal. They leave a small fontanelle in the middle line at their junction with the parietal. The outer free border of each is sharply depressed and slightly hollowed when seen from without ; this groove runs forwards to skirt the outer border of the nasals. The form which this groove ultimately acquires is of considerable importance for taxonomic purposes. (The nature and extent of these changes can be seen at a glance by comparing Pl. LXI. fig. 2 with Pl. LIX. fig. 2.) Thus, in the nestling the supra-orbital groove is represented by a shallow depression or hollowing out of the whole outer border of the frontal—the inner wall of the groove of the adult. The outer wall of the adult gradually arises from the inferior border of this inner wall, and eventually assumes the form of a huge overhanging ledge of bone with a wide, flattened, dorsal rim along its free edge. The condition of the groove in the adult skull of *Aptenodytes* affords a more or less intermediate stage between these two. It is interesting to note that Watson, in his memoir published in the ‘Challenger’ Reports (vol. vii. p. 6), described and figured the skull on which this description is based, and remarked that in “. . . . *Aptenodytes* and *Pygoscelis* this ledge of bone does not exist”

The *basioccipital*, seen ventrally, is bounded on its outer sides by the exoccipital, and in front by the basitemporal. Posteriorly it is rounded off to form the main body of the occipital condyle. Seen dorsally, it is bounded in front by the basisphenoid, laterally by the proötic, opisthotic, and exoccipital. At this stage, in a very young nestling of *Catarrhactes chrysocome*, all these boundaries are clearly defined in cartilage, save that between the opisthotic and proötic. Soon after this all traces of these limits become obliterated.

The *exoccipital* is for some considerable time separated from the squamosal by a wide gap filled in by cartilage, through which the proötic has thrust itself (Plate LXI. fig. 3). Its supero-internal dorsal border abuts against the epiotic and supra-occipital bones, both of which can be readily distinguished. Below, and externally, it develops a short paroccipital process, which, however, never acquires a large size ; separated from this by a wide groove is developed the mammillary process, abutting against the basioccipital at its junction with the basitemporal. Seen from within, the exoccipital appears as a small triangular area of bone wedged in between the opisthotic and the basioccipital and contributing to form the foramen magnum.

The *basisphenoid* is not visible externally, being concealed by the underlying basitemporal plate and its parasphenoidal rostrum. Internally, it is bounded, laterally, by the proötic and alisphenoid, posteriorly by the basioccipital, and anteriorly by the pre-sphenoidal cartilage. Its dorsal border is hollowed out to form the ventral segment of the optic foramen. In front of the pituitary

fossa it is continued forwards for a short distance in the form of a vertically compressed lamina resting on the parasphenoid.

The *orbito-* and *presphenoid* are as yet represented only by cartilage and are not to be separately defined.

The *alisphenoid* is more or less quadrate in shape. Its antero-dorsal border runs along the orbital plate and postorbital region of the frontal; its postero-dorsal border is arched and wedged in between the parietal and squamosal (Pl. LXI. fig. 3); its inferior border is deeply hollowed to form the upper segment of the trigeminal foramen; its antero-internal border joins the still membranous orbito-sphenoid, its lower angle contributing to form the optic foramen.

The *parasphenoid* externally is perfectly distinguishable. It may conveniently be divided into three regions:—(1) An elongated, median rostrum; (2) a pair of alisphenoidal wings; and (3) a pair of basitemporal wings, which last form the basitemporal plate (Pl. LXI. fig. 3). In the ventral view of the skull of a young *Pygoscelis papua* from which this description of the parasphenoid is taken, the anterior basicranial fontanelle and vestiges of basi-pterygoid processes are plainly seen. The rostrum is continued backwards to abut against the basisphenoid, expanding meanwhile into a pair of wings to form the basitemporal plate. This plate is narrow from before backwards, but extends laterally to the level of the outer border of the mammillary processes. Its anterior edge is free and forms the floor of the Eustachian grooves, which, later, become converted into tubes (p. 962). Seen laterally, this groove has the appearance of having been carved out of the base of the skull so as to present a steep face, looking forwards and at right angles to the main axis of the skull. The alisphenoid wings are separated from the basitemporal plate by a deep gorge, which later becomes converted into a tube for the internal carotid artery (Pl. LXI. fig. 3). They overlap the suture between the alisphenoid and proötic bones, and extend outwards as far as the trigeminal foramen. Immediately above the carotid canal lies a pneumatic foramen, which apparently terminates in the body of the basisphenoid. In sagittal section the basisphenoid cannot be distinguished from the basitemporal plate underlying it.

The *mesethmoid* remains distinct for some time, in the form of a vertical, linguiform plate of bone. Its posterior border is rounded and imbedded in a large interorbital plate of cartilage. Its anterior border is columnar. Its dorsal border expands laterally under the frontals and nasals, and, eventually, turns downwards as an ectoethmoidal ossification to rejoin the mesethmoid—forming a large olfactory cavity opening forwards and downwards into the posterior region of the olfactory chamber.

The *squamosal* varies somewhat in form. In *Aptenodytes*, *Catarrhactes*, and *Spheniscus* it takes the form of a vertically elongated bone. In the first-named its dorsal moiety is produced into anterior and posterior limbs, giving the whole a Y-shaped appearance; of these two limbs the anterior is the more pronounced.

In the two latter genera the anterior limb is wanting. In *Pygoscclis* (Pl. LXI. fig. 3) the vertical height is relatively less; the anterior limb is wanting, as in *Catarrhactes* and *Spheniscus*; the posterior is of considerable length. The anterior and dorsal borders, in *Pygoscclis*, form a right angle; the posterior is deeply hollowed, as seen in the figure. Between the free end of the posterior limb and the epiotic is a wide space; into the lower portion of this the proötic has thrust itself. The upper portion of this space was originally filled in by cartilage and formed the outer wall of the floccular fossa, as seen in the skull of a young *Catarrhactes*; it is now filled up by an inward growth of the posterior border of the parietal. Below the curved upper limb lies the proötic, which runs backwards to join the exoccipital. The extreme anterior end of the proötic is seen peeping out in front of the supero-anterior squamosal border behind the alisphenoid. The squamosal, at this stage, articulates with the parietal only and rests upon the outer surface of the proötic. It is entirely shut off from the cranial cavity.

The *epiotic* (Pl. LXI. fig. 3) is sharply divided from the supra-occipital by a wide cleft running downwards and inwards from the lambdoidal suture, which terminates at about the middle region of the epiotic in a groove—afterwards converted into a closed canal—for one of the cerebral veins. This groove divides the lower end of the epiotic, as does the cleft the upper end, from the supra-occipital. Seen from without it is bounded mesially by the supra-occipital, superiorly by the parietal, and laterally by the proötic and exoccipital. Its supero-lateral border is bounded by cartilage (a synchondrosis); its postero-lateral border by a close suture. Seen from within, the epiotic is found to be fused by its postero-internal border with the supra-occipital, from which it is separated above by the wide chink already described (p. 967). Its lateral and external border is separated synchondrosially from the proötic and lateral occipital. In conjunction with the proötic forms the floccular fossa.

The *proötic* is largely visible from without, till comparatively late in life (Pl. LXI. figs. 1 & 3). In the youngest skull from which these descriptions are taken (*Catarrhactes chrysocome*), it can be seen in the hinder region of the skull through a mass of cartilage forming a small island, between the exoccipital, squamosal, parietal, and epiotic. In the lateral view of the skull, after removal of the quadrate, it can be seen lying between the exoccipital behind and the alisphenoid in front: below it rests on the pretemporal wing of the basisphenoid; above it is covered by the squamosal. After the removal of this, the boundaries of its upper end can be clearly made out. It is found to be wedged in between the alisphenoid and parietal above and in front, the exoccipital behind, and the epiotic mass of the supra-occipital within. Its anterior border is deeply hollowed to form the posterior border of the trigeminal foramen. Behind and above lies a glenoid cavity for the quadrate. Its posterior border is also hollowed out to

form the anterior segment of the circular aperture of the fenestra ovalis.

The internal and external nasal processes are of great length; the former is the longer, and turns inwards at about its middle in the form of a long rod to underlie the nasal process of the premaxilla. The free border of the posterior, laminate portion of the nasal may meet in the middle line in the form of a rounded curve, or it may be interrupted in this region by the invasion of the interorbital ridge of the frontal, as in *Pygoscelis*.

The nasal processes of the premaxilla are cleft to within about one-fifth of the extreme tip of the jaw; the posterior, free ends of these processes rest upon the mesethmoid; on either side they are embraced by the nasals. The maxillary process runs above the maxilla, terminating near the middle of the inferior boundary of the lachrymo-nasal fossa.

The *maxilla* is produced forwards into a long slender splint, below the inferior border of the maxillary process of the premaxilla to within a short distance of its tip, thus forming almost the entire inferior border of the upper jaw, and backwards as a somewhat splint-like rod to assist in forming the quadrato-jugal bar. Above, it is bounded anteriorly by the maxillary process of the premaxilla and posteriorly above by the jugal, and below by the quadrato-jugal. Its backward extension terminates on a level with a line passing at right angles through the articulation of the pterygoid and quadrate. On the inner side, near its anterior $\frac{1}{3}$, on a level with the articulation of the external process of the nasal with the premaxilla, it gives off a curved rod-like maxillo-palatine process. The body of this is excavated to form the antrum of Highmore. These processes curve inwards on either side so as to embrace the vomer between them, though it does not actually touch them. They do not extend back beyond the level of a vertical line passing through the middle region of the lachrymals.

The *jugal* is a long slender splint, resting for the most part upon the posterior limb of the maxilla. It extends forwards, to the junction of the external process of the nasal with the maxillary process of the premaxilla, and backwards, along the outer side of the quadrato-jugal to within about one-fifth of its posterior articular end. The quadrato-jugal is of considerable size, extending forwards to the level of the posterior angle of the inferior pedate extremity of the lachrymal. The precise relations of the bones composing the quadrato-jugal bar can be well seen in Pl. LXI. fig. 3.

The *lachrymal* is permanently free, columnar in form, with a laminate or flange-like anterior border, and with expanded obliquely placed extremities. Its superior or dorsal end is applied to the under surface of the nasal, and its inner border to the anterior extremity of the frontal underlying the nasals. Generally the flange-shaped anterior border is perforated by a foramen, but this is not a constant character, the foramen being sometimes converted into a notch. In *Pygoscelis*, *Spheniscus*, and *Aptenodytes*

little, or nothing, of the lachrymal is visible when the skull is viewed dorsally, either in the young or adult. In *Catarrhactes* it appears as a narrow ledge outside the nasal. This fact, with some others, serves at once to distinguish the skull of any of the *Spheniscidæ* from that of any of the *Colymbidæ*, in which this bone forms a very prominent, outstanding process.

The *vomer*, which is permanently free, is double, but the two halves are united along the anterior half of the inferior border; the posterior half of the dorsal border of each articulates with the palatine of its own side.

The *palatines* underlie the maxillæ, and with them extend forward to within a short distance of the tip of the upper jaw. Posteriorly, in the region corresponding with the level of the lachrymal, the flattened, splint-like form becomes greatly expanded, and turns slightly inwards and dorsally. The anterior border assumes a more or less scroll-like form and sends forwards along each half of the vomer a short rod, which apparently never projects beyond the level of the anterior border of the mesethmoid. The outline of the posterior border varies slightly in the different genera and species.

The *pterygoid* is rod-shaped, greatly expanded and flattened distally. Like the palatine, it differs slightly in shape, and is accordingly of some help in identifying species and genera. In young birds, and in young birds only, it is continued from the articular end of the palatine, forwards over its dorsal border, in the form of an elongated triangular rod of bone, terminating in an acute point over the extreme posterior extremity of the vomer (Pl. LXI. fig. 3). Almost immediately behind the posterior end of the palatine, this anterior portion of the pterygoid becomes segmented off from the main body of the bone, and later, a perfect arthrodial joint is formed. Meanwhile, the triangular anterior end has fused with the palatine, making it appear that the joint at the distal end of the pterygoid is a true palato-pterygoid articulation. There is nothing to show that the joint is secondary, and that it is formed by the unequal segmentation of the pterygoid itself.

In some other forms this pterygoid segmentation takes place at the level of the posterior border of the palatine, instead of a little caudad of this.

This anterior segment has been frequently described and figured, in many different groups, by the late W. K. Parker, as a meso-pterygoid. A short time ago I gave a brief description (13) of what seemed to me to be the real significance of this stylet, not knowing then that this had been more or less clearly grasped by Menzbier (11). His description is, however, somewhat meagre, and neither here nor in his figure does he hint at the segmentation of the pterygoid which eventually takes place, though he must have been perfectly well aware that such a process occurred.

As Menzbier has pointed out, the relations of these parts which exist temporarily in the Penguin obtain permanently amongst the *Ratitæ*. *Dromæus* and *Rhea* furnish two admirable examples. In

the former, the pterygoid takes the form of an obliquely placed, flattened lamina tapering to a point forwards. The ventral border of its anterior half rests upon the flange-like projection from the dorsal border of the posterior limb of the paired vomer: the two becoming, in the adult, entirely fused so as to leave no trace of the line of their union.

In *Rhea* it is of exactly the same shape anteriorly as the small splint in Spheniscidæ, and runs forward along the dorsal border of the posterior end of the vomer, just as, only to a greater extent, it does in the young Carinate skull. In the case of *Rhea*, however, the inferior surface of this end of the pterygoid is grooved, and into this groove the postero-internal angle of the palatine and the outer superior border of the posterior limb of the vomer are received.

That this "hemipterygoid"¹, as I propose to call this anterior segment of the pterygoid, in the Carinatae, is a part of the true pterygoid, and that it represents an earlier phase when the relations between the pterygoid and vomer were precisely similar to what obtains amongst the Ratitæ and Tinamous at the present day, is highly probable. Originally then, in the "Carinatae," as in the "Ratitæ" now, the pterygoid terminated in a point resting on the vomer and was unsegmented; since, it has divided into an anterior and a posterior moiety, a joint forming between the segments. The pterygoid of the adult represents only the posterior and larger portion, the anterior having fused with the palatine. This state of things may probably be interpreted as the result of mechanical stress causing a fracture at the weakest part of the bone, such stress being brought about by the shifting of the palatines towards the middle line from their originally dromæognathous position.

From the relations between pterygoid and vomer, we may turn profitably to the relations between pterygoid and palatine.

In the Ratitæ, as represented by *Dromæus* and *Rhea*, the palatines are more or less triangular in form and do not extend forwards beyond the level of the posterior border of the maxillo-palatine processes. In the Carinatae they extend forwards by means of a rod-like splint nearly to the tip of the upper jaw.

In *Dromæus* the palatine is attached to the outer border of the dorsal surface of the posterior limb of the vomer on each side, and is not in any way connected with the pterygoid. Thus, on a ventral view of the skull, the vomer is continued directly backwards to the pterygoids, its two posterior limbs forming with each of the latter a continuous bar. In *Rhea* the anterior half of the internal, or mesial, border of the palatine articulates with the posterior limb of the vomer of that side, the posterior half with the pterygoid. Thus the vomer appears to be entirely separated from the pterygoid by the palatine. Moreover the latter is being

¹ For this word I have to thank Prof. G. B. Howes, F.R.S., of the Royal College of Science, whose aid I sought after having failed to coin a name to my own satisfaction.

slowly brought into relation with the parasphenoidal rostrum. If the palatine be carefully removed, however, the spine-like anterior end of the pterygoid will be found to run along the superior border of the posterior limb of the vomer, though for a short distance only. The condition of things which obtains here between the pterygoid and vomer permanently is represented, more or less perfectly, for a short time in the life-history of many, if not all, *Carinatae*.

But to return to the palatines. In *Carinatae* more or less of the anterior region of the internal border of each palatine articulates with the vomer—which, though still paired, is generally more or less blade-shaped, and not, as in the *Ratitae*, depressed and laterally expanded; the remainder, meeting its fellow of the opposite side below the parasphenoidal rostrum, runs back to articulate with the pterygoid. Thus, in a ventral view of the skull, the vomer lies wedged in between the palatines and appears to be far removed from the pterygoids, having apparently been thrust forwards by the approximation of the palatine toward the middle line. Seen dorsally, however, in the young skull, the internal palatine border is found to be still in part connected with the vomer and in part with the pterygoid, as in *Rhea*—the connection being made by means of the hemipterygoid. If this connection is now in a vanishing quantity, it still undeniably exists.

The Mandible.—All the elements which take part in the formation of the lower jaw are present (Pl. LXI. figs. 1 & 3). The relations between the coronoid and splenial most nearly resemble those of the *Crocodylia* amongst the Reptiles, the coronoid lying behind the splenial. In its elongated form and superior size, however, the coronoid differs from all the Reptilia, and resembles the rest of the Aves. Within the Class, the form and relations of these two bones one to another and to the neighbouring parts vary slightly, and may prove to be characters of some value in systematic work. In a young *Catarrhactes chrysocome*, as shown in Pl. LXI. fig. 1, the coronoid extends from behind forwards as far as the middle of the ramus. Its posterior end is expanded and closely applied to the articular, from which, however, it can be clearly distinguished. The splenial is a large lozenge-shaped lamina lying in front of, and below, the anterior end of the coronoid. The greater part of its superior border is overlapped by the dentary. The articular is wedged in between the posterior ends of the coronoid, on the inside, and the supra-angular and angular, on the outside. The supra-angular runs forwards to join the dentary at about the middle of the ramus. It is perforated, rather behind its middle, by the posterior lateral vacuity. The angular underlies the supra-angular, and forms the inferior border of the jaw from the dentary backwards; it appears on the inside, where it overlaps the coronoid for some considerable distance. Its extreme anterior end is concealed on the inside by the splenial, on the outside by

the dentary. The form of the dentary supra-angular suture has been described in the adult (see p. 965).

iv. THE VERTEBRAL COLUMN.

The vertebral column is singularly uniform in character throughout the group. The cervicals are peculiar chiefly on account of the great development of the metapophyses and hyperapophyses of certain vertebræ.

The thoracic vertebræ are opisthocœlous and somewhat closely resemble those of *Phalacrocorax*, from which they may be distinguished by the great development of the styloid processes, seated on the anterior border of the transverse process midway between the capitular articulation for the rib and the centrum. The synsacral hypapophyses found in *Phalacrocorax* are absent in the Penguins.

The synsacrum is a dense bony mass which remains unanchylosed with the innominate bones throughout life. On a ventral view, the lumbar swelling is seen to be very large. The outer ends of the last thoracic and the first two lumbar vertebræ fuse together to enclose a pair of holes on each side: behind, in the middle of the lumbar enlargement, are seated a pair of short, thick parapophyseal elements abutting against the ilium. The renal fossa cannot be definitely separated into anterior and posterior portions. The true sacral vertebræ are not, in very old specimens, easy to make out: they are enclosed in the hexagonal mass lying opposite the acetabulum and ilio-ischiadic foramen. Three vertebræ take part in the formation of this mass, of which the 2nd and 3rd represent the two primitive sacrals. From 1 to 3 of the caudals may be included in the synsacrum, according to age. None of the synsacral vertebræ bear hypapophyses. Dorsally, the region of the synsacrum, between the hexagonal sacral mass and the first pair of parapophyseal elements anterior to this, is much expanded. In the complete pelvis this lies immediately cephalad of the acetabulum. In the region behind this it is more or less constricted. The synsacrum is composed of from 12-14 vertebræ. The pygostyle (Pl. LXI. fig. 5) is composed of about 6 vertebræ, the neural spines of which run directly forwards and parallel with the vertebræ and overlap the spine next in front. The vertebræ cannot be generically distinguished.

There are from 9-10 pairs of free ribs. The first two pairs are those of the cervico-thoracic vertebræ. Of these, the first takes the form of an elongated bony style; the second represents a complete dorsal rib, but has no sternal segment, and bears an uncinatè process. The remaining ribs increase in length and slenderness from before backwards, and all but the last bear uncinatès. These, in the 1st to 4th ribs, are very long and broad. There is frequently, perhaps always, an extra pair of sternal ribs closely attached to the posterior border of the sternal segment of the last thoracic rib.

V. THE PECTORAL GIRDLE AND STERNUM.

The pectoral girdle of the adult Penguin is of the same general form throughout the group.

The *coracoid* is a stout bone, typically about half as long as the sternum. The *precoracoid* is large in all. In an example of *Pygoscelis papua* it extends almost the whole length of the coracoid. The *supracoracoid* foramen is complete in all but *Aptenodytes* and *Pygoscelis*. The *acroracoid* is fairly well developed; in *Pygoscelis* and *Spheniscus magellanicus* it forms a conspicuous, downward and inwardly projecting spur.

The form of the scapula is unique, being of great length and shaped like a scimitar; the convex border is dorsal, the concave ventral. In *Aptenodytes* and *Pygoscelis* it is sharply truncated posteriorly; in *Spheniscus* and *Eudyptula* the inferior angle of this posterior border is rounded off, so that the free end of the bone assumes a somewhat pointed form. That of *Catarrhactes* can be more or less distinguished from that of *Spheniscus* by the greater curvature of its superior border, and the acute angle formed at the hinder end of the inferior border, giving the scapula a truncated appearance posteriorly, similar to that of *Aptenodytes*. In *C. chrysolophus*, however, this is less marked, and makes it somewhat difficult to distinguish from the scapula of *Spheniscus*. There is a well-marked acromial process for the articulation of the free end of the clavicle.

The *furcula* is U-shaped and much curved, its convexity looking forwards and downwards. There is no hypocleideum. Its free end forms a slight roughened expansion for articulation with the acromial process of the scapula. Ventrad of this is a more or less oval irregular surface for articulation with the acroracoid. From the level of this articulation downwards, the limbs of the furcula are laterally compressed, but they gradually take on a rounded form as they approach the symphysis.

The *sternum* is about half as broad as long, with a pair of notches posteriorly. The keel in all cases projects beyond the corpus sterni. In *Aptenodytes* this is a very marked feature indeed, the anterior border sloping obliquely forwards and downwards for about one-sixth of the total length of the sternum. In all but *Aptenodytes* there is a well-marked *spina externa*. This is more or less marked by the forward continuation of the keel. In some it is well marked. In *Aptenodytes* the anterior border of the keel passes directly into the *corpus sterni*. The form of the *spina externa* and of the anterior border of the keel is very variable, even among species of the same genus, so that no value can be placed on it as a systematic factor. There is no *spina interna*.

The anterior lateral processes project forwards and outwards, the base of each on either side runs from the inner end of the coracoid groove outwards to the external border of the *corpus sterni*. Along this border, at the point where the two regions may be said to meet, is placed the articular surface of the sternal segment of

the 1st thoracic rib. There are altogether 6 of these articular surfaces.

The coracoid grooves are widely separated in the median line; the "dorsal lip" is represented by a slight projection near the inner end, and the "ventral lip" by a somewhat more developed process near the outer end, of the groove. The groove is slightly curved, its convex surface being ventral, fairly wide, and deep.

The posterior lateral processes are of great length in *Aptenodytes* and *Pygoscelis*, longest in the latter, where they may exceed the coracoid in length. They are slightly curved (outwardly), and tend to meet in the middle line behind the metasternum throughout the group. Only in *Catarrhactes chrysolophus* and *Eudyptula minor* are they so curved as to make the width across from the process of one side to that of the other so great as to be equal to (*Eudyptula*) or greater than (*Catarrhactes*) that across the anterior lateral processes. The width of the posterior lateral processes themselves varies slightly. From near the middle of each process there arises a strong ridge, which runs forwards to terminate in the lateral border of the *corpus sterni*; which, it should be remarked, is bent, or reflected downwards to form a wide overhanging ledge on each side of the sternum. The metasternum is variable in shape, being either pointed or rounded in form.

The sternum remains as a single cartilaginous plate with a low median keel till long after the coracoids and scapula have ossified. In a half-grown *A. forsteri* in the Collection, the sternum is represented by a pair of rhomboidal plates fused in the middle line from before backwards to the posterior third, where they remain widely separated. The keel is very feebly developed, and, as in *Steganopodes*, is produced far forwards beyond the level of the sternum, and tapers rapidly backwards to disappear in the neighbourhood of the sternal cleft just referred to.

vi. THE PELVIC GIRDLE. (Fig. 1, p. 979.)

The pelvis of the Impennes is not readily comparable with that of any other group. Its most distinctive character is the great backward rotation of the innominate bone. This is readily seen if the pelvis is held so as to bring the synsacrum to the vertical. A line drawn through the pre-iliac and pubis would describe an angle of about 25°. Both external and internal borders of the pre-iliac are greatly hollowed immediately in front of the acetabulum. The ilio-ischiadic foramen never greatly exceeds the acetabulum in size. The obturator foramen is never complete. The pubis (*pb.*) never greatly exceeds the ischium (*is.*) in length, is nearly or quite straight, and runs parallel with the ischium, leaving a long obturator fissure. Its free end never turns inwards. The ischium is fused with the post-iliac, beyond which it projects slightly, and, like the post-iliac, tapering to a point posteriorly forms a notched posterior border. The post-iliac is expanded immediately over the ilio-ischiadic foramen; behind this it forms a sharp ridge projecting considerably on either side above the level of the synsacrum.

Except in *Pygoscelis papua*, the innominate bones remain widely separated by, and free from, the synsacrum throughout life. The pre-ilium in no case quite reaches the fused neural spines of the synsacrum; in *Aptenodytes* the pre-ilia are more markedly separate than in any other genus.

In a nestling *Aptenodytes* the acetabulum is bounded, anteriorly by the pre-ilium, posteriorly by the ischium and pubis. The ischium bears a share in the formation of the antitrochanter. The pubis is nearly as broad as the ischium and only slightly longer; the post-ilium falls far short of the hinder end of the ischium, from which it can be easily distinguished by a faint line running forwards to the ilio-ischiadic foramen. It is noteworthy that it is not divided by a fissure from the ischium as in the young of many other birds, or as in the case of the Struthious birds and Tinamous. This is probably a secondary feature due to the extreme backward rotation of the ischium and pubis. The anterior and posterior renal fossæ are not sharply defined. The synsacral foramina in the acetabular region are minute. The form of the pelvis is very uniform throughout the group: such points as are of systematic value will be found in the appended "Keys."

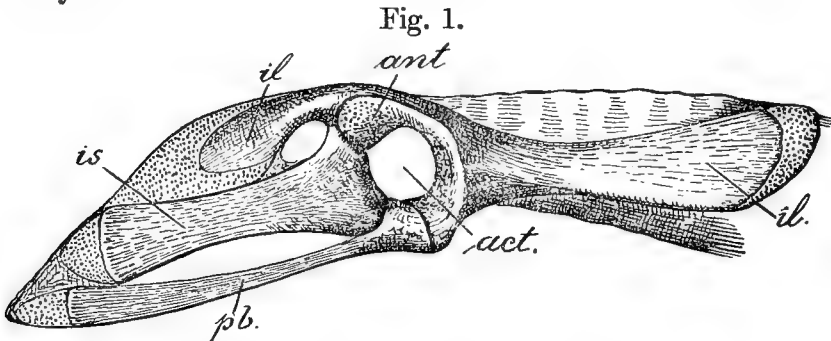

Fig. 1.
Lateral view of the innominate of a nestling *Catarrhactes chrysocome*, to show the separate elements.

ant., anti-trochanter; act., acetabulum; il., ilium; is., ischium; pb., pubis.

vii. THE PECTORAL LIMB.

The bones of the wing in the Impennes can only very imperfectly be distinguished either specifically or generically one from another. The wing of *Aptenodytes* can be distinguished from that of any other genus by its superior size, the humerus being not less than 4.4 inches in length. That of *Pygoscelis papua* comes next, being 3.5 in. Except in the slightly superior size of the pneumatic fossa, the wing of the smaller species of *Pygoscelis* cannot be distinguished from that of *Catarrhactes* or *Spheniscus*. The last two genera are almost indistinguishable one from another. That of *Spheniscus* may perhaps be distinguished from that of *Catarrhactes* by the size of the ulnare. This, in all, is triangular in shape, but in *Spheniscus* only, apparently, is the width of the base—the postaxial border—but slightly greater than the height;

in other genera the base of the triangle greatly exceeds the height from base to apex. *Eudiptula* is easily distinguishable from the remaining genera on account of its small size; the ulna does not exceed 2 in. in length—the whole wing is under 5 in.

The most striking feature of the wing is the remarkable compression or flattening, dorso-ventrally, which the bones have undergone. The sub-trochanteric (pneumatic) fossa of the humerus is of great size, as in many Anatidæ; in the Penguins, however, the fossa is non-pneumatic. The pectoral crest does not project beyond the level of the shaft; the pectoralis major is inserted into a deep oblong fossa on its ventral aspect. The coraco-humeral groove is well-marked. The head of the humerus is reniform, the hilus being ventral. The distal articular end is obliquely truncate; the radial and ulnar condyles lie one behind the other, and from behind the latter the shaft is produced into a sharp angle, the free border of which is grooved; there is a second groove dorsad of this perfected by a large projecting upper lip. In these two grooves run two sesamoids, the form and relations of which have been frequently described.

In a half-grown nestling of *C. chrysocome* the 1st metacarpal is quite separate from the 2nd and tipped with cartilage—representing the 1st phalanx. The terminal phalanges of the 2nd and 3rd metacarpals are likewise tipped with cartilage, and similarly may represent phalanges. The ulnare at this stage is entirely cartilaginous.

viii. THE PELVIC LIMB.

The most characteristic feature of the pelvic limb is the distinctness of the three metatarsals, usually merged together into a longer or shorter single cylindrical shaft. In the Penguins 3 metatarsals are always distinguishable, separated one from another by grooves more or less deep. On either side of the 3rd metatarsal, on anterior view, lie 2 foramina; just below the insertion for the tibialis anticus these pass through to appear just below the bases of the two more or less distinct calcaneal ridges. The form of the tarso-metatarsus in the Impennes is closely approached by that of *Fregata* (a Steganopodous bird); but it can easily be distinguished therefrom by the fact that in *Fregata* the 2nd trochlea is longer than the 3rd and is directed backwards, and by the presence of a foramen at the distal end between the 3rd and 4th trochleæ. In *Sphenisci* this foramen is wanting, and the 2nd trochlea is shorter than the 3rd and is not directed backwards. It has been suggested that this distinctness of the metatarsals in the Impennes is pseudo-primitive and probably induced by the plantigrade habit of walking. The Penguins are, however, *not* plantigrade; and it is a significant fact that both in this group and in *Fregata* the legs are comparatively little used for the support of the body. Thus it is possible that on this account the metapodial region may have retained a nearer approach to the primitive condition than in other forms. They represent a halfway stage between the

primitive, completely separate metatarsals on the one hand, and the highly specialized "cannon bone" on the other, where the three metatarsals are all merged to form a single shaft.

The total length of the tarso-metatarsus is about one-fourth that of the tibio-tarsus. The hypotarsus is simple, consisting of an ecto- or an ecto- and entocalcaneal ridge, but they are never more than low prominences.

The tibio-tarsal shaft is perfectly straight, and about one-fifth longer than the fibula. Ecto- and entocnemial crests are well-developed in the adult, but there is no trace of them in the half-grown *C. catarrhactes* from which this description was taken.

The shaft of the femur is very thick, its length about twice that of the tarso-metatarsus. Like all the other bones of the leg, it is non-pneumatic.

ix. SUMMARY.

Mr. Grant (10) and I both find it necessary to divide the Order Impennes into 6 genera (*cf.* p. 982). Of these, *Eudypitula* appears to represent the least specialized form of the whole group, and probably lies nearest the ancestral stock. The diagram (*fig. 2*) is intended to express, as nearly as may be, the possible relationship of the various genera one to another. As has been already pointed out by Gadow (7) and Beddard (1), the group as a whole seems to be most nearly related to the Tubinares.

Fig. 2.

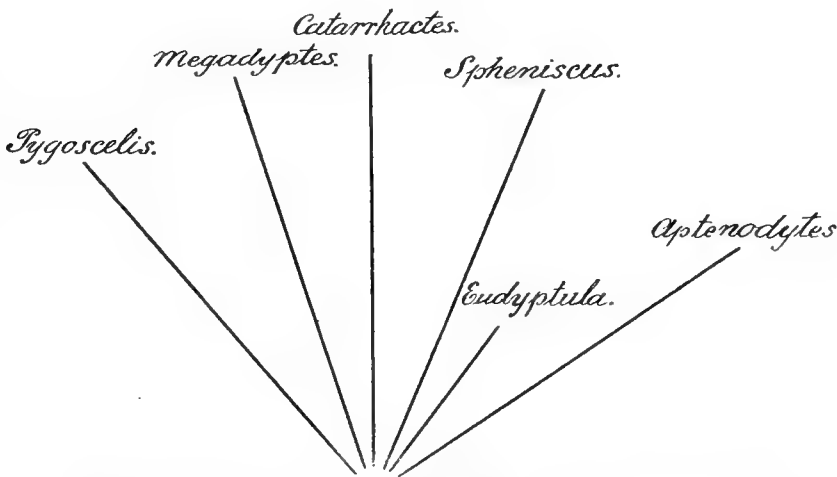

Diagram showing the probable relationships of the various genera of the Family Spheniscidæ.

I am unable to distinguish the skeleton of *Catarrhactes pachyrhynchus* from that of *C. chrysocome*. *C. sclateri* and *C. schlegeli* are not yet represented in the collection of skeletons. Skeletons of *Spheniscus humboldti* and *S. mendiculus* are also wanting.

X. KEY TO THE OSTEOLOGY OF THE IMPENNES,
based on characters of the adult skeleton.

A. SKULL (Plates LIX.-LXI.)¹.

Beak never hooked; nares pervious, holorhinal; basiptyergoid processes absent; palate schizognathous; vomer blade-shaped, paired, the two halves united along the antero-ventral border, never anchylosed with the palatines; palatines broad and flattened posteriorly; pterygoids expanded into flattened laminæ distally, never rod-shaped; interorbital septum perforate; with deep supra-orbital grooves; lachrymal free, never contributing to form the supra-orbital grooves, and without conspicuous squamoso-parietal wings when the skull is seen dorsally, its lower limb pedate, articulating with the quadrato-jugal bar; maxillo-palatine processes in the form of slender curved rods, never laminate.

Key to the Genera.

- A. Posterior region of the temporal fossa not extending on to the cerebellar prominence; the squamoso-parietal wing bounding the fossa posteriorly, terminating on the cerebral dome at or below the level of a long transverse lambdoidal ridge; coronal ridge absent.
- a. Quadrato-jugal bar greatly curved.
- a'. Supra-orbital ledge feebly developed, decreasing in size from behind forwards and becoming obsolete at the level of the frontal end of the nasal bones; supra-orbital grooves closed posteriorly by a strong bony wall; posterior ends of nasal processes of premaxilla separate one from another and from the nasals throughout life... *Aptenodytes*.
- b'. Supra-orbital ledge greatly developed, with its free edge flattened dorsally.
- a''. Width of coronal ridge much exceeding the width across nasals between lachrymals; squamoso-parietal wings feebly developed; posterior region of temporal fossa shallow.
- a³. Nasal processes of the premaxilla slender, free posteriorly one from another and more or less easily distinguishable throughout from the superior limb of the nasals; inferior border of the squamosal prominence longer than that of the paroccipital process; width of supra-orbital groove exceeding the height of the vertical axis of the foramen magnum; lower jaw with the inferior limb of the posterior (caudad) end of the dentary with a straight superior border *Pygoscelis*.
- b³. Nasal processes of the premaxilla conspicuously thickened, fused posteriorly more or less completely one with another and with the superior limb of the nasal; inferior border of the squamosal prominence less than that of the paroccipital process; width of supra-orbital groove less than the vertical axis of the foramen magnum; lower jaw with inferior limb of posterior end of dentary short and deep, and with a strongly pronounced siruous free border *Catarrhactes*.
- b''. Width of coronal ridge not exceeding width across nasals between the lachrymals; squamoso-parietal wings well developed; posterior region of temporal fossa wide and deep; nasal processes of premaxilla slender, free posteriorly one from another and from the superior limb of the nasals; inferior borders of squamosal prominence and paroccipital process equal; width of orbital groove less than height of vertical axis of foramen magnum; lower jaw having the inferior limb of the posterior end of dentary produced far backwards, and with a strongly arched superior border... *Megadyptes*.

¹ Of the Keys appended, that of the skull expresses the systematic arrangement adopted in this paper. The rest are designed not for systematic work, but for the purpose of facilitating the identification of the different parts of the skeleton when isolated.

- b.* Quadrato-jugal bar slightly curved.
- c.* Supra-orbital ledge nearly obsolete, not extending far beyond the base of the postorbital process; supra-orbital groove shallow, bounded posteriorly by a bony ridge *Eudiptes*.
- B.** Posterior region of the temporal fossa very deep, extending mesially on to the cerebellar prominence, separated dorsally from its fellow of the opposite side by a median sagittal ridge; transverse lambdoidal ridge absorbed by the squamoso-parietal wings, which are largely developed; with a coronal ridge distad of the sagittal crest *Spheniscus*.

Key to the Species.

APTENODYTES.

- a.* Upper jaw slightly longer than the cranium ($\frac{1}{4}$ in.); squamoso-parietal wings almost obsolete; coronoid of lower jaw long, extending far forwards above middle of splenial, terminating near the middle of the jaw. *A. forsteri*.
- b.* Upper jaw markedly longer than cranium, more than $\frac{1}{2}$; squamoso-parietal wings extending nearly the whole height of the temporal fossa; coronoid short, not extending beyond the posterior $\frac{1}{3}$ of the jaw ... *A. patagonicus*.

PYGOSCELIS.

- a.* Dorsal border of free edge of supra-orbital ledge of great breadth (Pl. LIX. fig. 2); posterior region of temporal fossa moderately deep; total length of skull 6 in. *P. papua*.
- b.* Dorsal border of free edge of supra-orbital ledge about $\cdot 1$ to $\cdot 2$ in width; skull less than 5 in. long; interorbital region of frontal immediately behind nasals reduced to a slender ridge dividing the supra-orbital grooves.
- a'.* Upper jaw not greatly depressed, markedly longer than cranium; pterygoids longer than vomer; length of anterior nares equals width across skull behind the postorbital processes *P. antarctica*.
- b'.* Upper jaw markedly depressed, equal to or less than cranium in length; pterygoids equal vomer in length; length of anterior narial aperture much less than width of skull behind postorbital processes. *P. adeliae*.

CATARRHACTES.

- a.* Inter-orbital region of frontals behind the nasals forming a broad ridge.
- a'.* Size smaller; not exceeding 4.3 in. { *C. chrysocome*.
C. pachyrhynchus.
- b'.* Size larger, not exceeding 4.6 in. *C. chrysolophus*.

EUDYPTULA.

- a.* Skull 3.5 in.; transverse lambdoidal ridge equals length of narial aperture. *E. minor*.
- b.* Skull 3.8 in.; transverse lambdoidal ridge less than length of narial aperture. *E. albosignata*.

SPHENISCUS.

- a.* Squamoso-parietal wings greatly developed, superiorly separated from the coronal ridge by a long and often wide sagittal ridge; cerebellar dome not well developed; supra-orbital ledge sharply truncated anteriorly in the region of the posterior $\frac{1}{3}$ of the supra-orbital groove... *S. demersus*.
- b.* Squamoso-parietal wings well developed, superiorly running forwards so as nearly to join the coronal ridge; supra-orbital ledge obsolete. *S. magellanicus*.

B. VERTEBRÆ.

All the presynsacral vertebræ are free; all the thoracic vertebræ are opisthocœlous; all the cervicals, save the atlas and axis, have a bony carotid canal, formed by an outgrowth from the lower surface of the anterior zygapophysis which extends downwards to the capitulum of the cervical rib; there are eight caudals, not including the pygostyle, which is made up of about six vertebræ.

Key to the Genera.

- A. Neural spines on 2-6; 5-9 with elongated cervical ribs; 2-4 with moderately large hyperapophyses; 12-14 with large metapophyses; last cervical and first dorsal with 1 to 3 bifurcate hypapophyses. *Aptenodytes*.
- B. Cervicals 4-11 with elongated ribs, on 4 and 5 in *P. taniata* extending back to the end of the centrum; 2-5 with very long hyperapophyses; 12-14 with much elongated metapophyses; last cervical and first 4 thoracic vertebræ with bifurcate hypapophyses..... *Pygoscelis*.
- C. Cervicals 4-9 with elongated ribs; 2-5 with elongated neural spines; 2-8 with much elongated hyperapophyses decreasing from before backwards; 11-12 with elongated metapophyses; first and second thoracic vertebræ only with bifurcate hypapophyses *Catarrhactes*.
- D. Cervical ribs of 5-8 vertebræ only conspicuous; in vertebræ anterior and posterior to these, the rib scarcely projects beyond the lateral and ventral laminæ forming the carotid canal; hyperapophyses on 3-6; metapophyses of posterior cervicals (12-13) not greatly elongated; hypapophyses of last cervical and 1-3 thoracic vertebræ bifurcate.

{ *Spheniscus*.
Eudyptula.

The vertebral formula is:—

Cv. 13; Cv. th. 2; Th. $\underbrace{5+1}_6$; Lb. 4; Lb. sc. 4; Sc. 2; Cd. $\underbrace{1+9}_{10}=41$.

C. STERNUM AND PECTORAL GIRDLE.

Corpus sterni half as broad as long, with a pair of notches posteriorly, a spina externa, and with the keel projecting forwards beyond *corpus sterni*; precoracoid and acrocoracoid large; scapula of great breadth and truncated posteriorly.

Key to the Genera.

- A. Length of coracoid equal to distance from anterior border of corpus sterni to the middle of the posterior lateral process; length of posterior lateral process less than that of coracoid; anterior border of keel projecting far forwards *Aptenodytes*.
- B. Length of coracoid less than the distance from anterior border of sternum to middle of posterior lateral process.
 - a. Posterior lateral process equal to or longer than the coracoid; supracoracoid foramen rarely complete *Pygoscelis*.
 - b. Posterior lateral process less than coracoid; supracoracoid foramen complete.
 - a'. Length of sternum more than 3 in.
 - a''. Posterior end of scapula truncated ¹*Catarrhactes*.
 - b''. Posterior end of scapula rounded *Spheniscus*.
 - b'. Length of sternum not exceeding 3 in. *Eudyptula*.

¹ The form of the scapula in *C. chrysolophus* closely approaches that of *Spheniscus*, from which genus the sternum and shoulder-girdle of this species can be easily distinguished by reason of the great width across the posterior lateral processes (see p. 978).

Key to the Species.

CATARRHACTES.

- a.* Width across widest part of synsacrum—dorsal view—much greater than depth of post-ilium from dorsal to ventral border ... *C. chysolophus*.
b. Width across widest part of synsacrum equal to depth of post-ilium.
 { *C. chrysocome*,
 { *C. pachyrhynchus*.

PYGOSCELIS.

- a.* Innominate free; median synsacral ridge not expanded in region of acetabulum *P. adelæ*.
b. Innominate fused with synsacrum; median synsacral ridge expanded in acetabular region *P. papua*.

APTENODYTES.

- a.* Size larger; total length 9·7 in.; synsacrum not greatly constricted in antitrochanteric region *A. forsteri*.
b. Size smaller, not exceeding 8·5 in.; synsacrum much constricted in antitrochanteric region *A. patagonicus*.

EUDYPTULA.

- a.* Size larger, not exceeding 3·4 in. *E. albosignata*.
b. Size smaller, not exceeding 3 in. *E. minor*.

SPHENISCUS.

- a.* Pre-ilium truncated anteriorly *S. demersus*.
b. Pre-ilium rounded anteriorly *S. magellanicus*.

E. PECTORAL LIMB.

All the bones much flattened dorso-ventrally; humerus with a large, non-pneumatic fossa at its proximal end, obliquely truncated distally, and grooved for large, ossified sesamoids; ulnare of great size, and more or less triangular in outline; Mc. I. fused with Mc. II., and without phalanges.

F. PELVIC LIMB.

Width across the tarso-metatarsus nearly as great as the length. Metatarsals more or less perfectly separated one from another by grooves; no ectotrochlear foramen; 2nd trochlea shorter than the 3rd, and not directed backwards.

Key to the Genera.

- A. Anterior face of tarso-metatarsal region (proximal end) flattened, not scooped out so as to be overhung by the fused tarsals; interosseous metatarsal foramina large and conspicuous; of the three metatarsals the median is distinctly the shortest; entocalcaneal crest distinct; ento- and ectocnemial crests well developed and enclosing a deep gorge; ectocnemial crest directed forwards and running down shaft as far as upper third of fibular ridge; insertion of tibialis anticus marked by a slightly hollowed oval scar in upper third Met. III. *Aptenodytes*.
 B. Anterior face of tarso-metatarsal region (proximal end) slightly depressed; interosseous metatarsal foramina small; intermetatarsal grooves shallow; of the three metatarsals the III. is the shortest; calcaneal crests obsolete; ectocnemial crest directed outwards, not continued down the shaft; ento- and ectocnemial crests do not enclose a deep gorge *Pygoscelis*.

- C. Anterior face of tarso-metatarsus (proximal end) markedly depressed or scooped out; interosseous metatarsal foramina small.
- a'. Inner intermetatarsal groove very shallow, outer deep; ectocnemial crest small, directed outwards; ecto- and entocnemial crests not enclosing a deep gorge as in *Aptenodytes*; ecto- and entocalcaneal crests moderately developed *Catarrhactes*.
- b'. Inner and outer intermetatarsal grooves deep and long; inner and middle metatarsals laterally compressed, with a distinct tubercle for the tibialis anticus; ento- and ectocnemial crests enclosing a deep but short gorge *Spheniscus*.
- c'. Intermetatarsal grooves distinct; ento- and ectocnemial crests slightly developed, enclosing a narrow and not very deep gorge.. *Eudyptes*.

xi. LIST OF THE PRINCIPAL WORKS REFERRED TO AND CONSULTED.

1. BEDDARD, F. E.—'Structure and Classification of Birds,' 1898, p. 396.
2. BRANDT, J.—'Beit. zur Kennt. des Naturgesch. Vögel.' V. Abth. p. 213. Mém. Acad. Imp. des Sci. St. Pétersb. vi. pt. 2, 1839.
3. COUES, E.—'Materials for a Monograph of the Spheniscidæ (II.)' Proc. Acad. Nat. Sci. Philad. 1871-2, p. 181.
4. COUES, E.—'Osteological Notes.' Proc. Bost. Soc. xiv. p. 251, 1872.
5. FILHOL.—'Observ. relatives aux Caractères ostéol. Espèces d'*Eudyptes* et *Spheniscus*.' Bull. Soc. Philom. (7) vi. p. 226, 1882-3.
6. FÜRBRINGER, M.—'Untersuch. zur Morphol. und Syst. der Vögel,' 1888, p. 1588.
7. GADOW, H.—'Bronn's Thier-Reich,' Bd. vi. Vögel, 1891, Anatom. Theil.
8. GADOW, H.—Ibid., Systematisch. Theil, 1893.
9. GERVAIS et ALIX.—'Ostéologie et Myologie des Manchots ou Sphéniscides.' Journ. de Zool. vi. 1877, p. 433.
10. GRANT, W. R. O.—'Impennes.' Catal. Birds Brit. Mus. 1898, xxvi. p. 623.
11. HUXLEY, T. H.—'On the Classification of Birds.' P. Z. S. 1867.
12. LYDEKKER, R.—'Cat. Foss. Birds Brit. Mus.' 1891.
13. MENZBIER, M. v.—'Vergleichende Osteologie der Pinguine.' Bull. Soc. Impér. Natur. de Moscou, 1887.
14. PYCRAFT, W. P.—A communication concerning the Avian mesopterygoid. Bull. Brit. Orn. Club, no. LV. p. lviii, 1898.
15. PYCRAFT, W. P.—'Contributions to the Osteology of Birds. Part I. Steganopodes.' P. Z. S. 1898, p. 86.
16. PYCRAFT, W. P.—'Catal. Birds Brit. Mus.' vol. xxvi. 1898, p. 623.
17. REID.—'Anatomical Description of the Patagonian Penguin.' P. Z. S. 1835, p. 132.
18. WATSON, M.—'Report on the Anatomy of the Spheniscidæ.' Voy. Chall. Exped. vol. vii., 1883.

EXPLANATION OF THE PLATES.

PLATE LIX.

<i>c.p.</i> = cerebellar prominence, dome.	<i>p.</i> = palatine.
<i>c.r.</i> = coronal ridge.	<i>s.c.</i> = sagittal crest.
<i>l.</i> = lachrymal.	<i>sq.p.r.</i> = squamoso-parietal ridge.
<i>n.</i> = nasal.	<i>t.f.</i> = temporal fossa.
<i>n.p.m.x.</i> = nasal process of premaxilla.	

The Dorsal Aspect of the Skull.

- Fig. 1. The skull of *Spheniscus magellanicus* Forst., to show the great size of the temporal fossa and of the squamoso-parietal wings; the sagittal crest, coronal ridge, and the slight development of the supra-orbital ledge.
- Fig. 2. The skull of *Pygoscelis papua* Forst., to show the great development of the supra-orbital ledge, the free nasal processes of the premaxilla, the form of the temporal fossa, and the lachrymal.
- Fig. 3. The skull of *Aptenodytes patagonica* Forst., to show the supra-orbital ledge, the free nasal processes of the nasal processes of the premaxilla, the shallow temporal fossa, and great width at the transverse lambdoidal ridge.
- Fig. 4. The skull of *Eudyptula albosignata* Finsch, showing the almost complete absence of a supra-orbital ledge and the form of the temporal fossa.
- Fig. 5. The skull of *Catarrhactes chrysocome* Forst., to show the form of the supra-orbital ledge and of the temporal fossa.

PLATE LX.

<i>a.</i> = angulare.	<i>p.o.p.</i> = postorbital process.
<i>a.o.p.</i> = antorbital plate.	<i>p.p.</i> = paroccipital process.
<i>c.p.</i> = cerebellar prominence.	<i>p.m.x.</i> = premaxilla.
<i>d.s.</i> = dentary suture.	<i>pt.</i> = pterygoid.
<i>i.o.s.</i> = interorbital septum.	<i>q.</i> = quadrate.
<i>l.</i> = lachrymal.	<i>v.</i> = vomer.
<i>p.</i> = palatine.	

The Lateral Aspect of the Skull.

- Fig. 1. The skull of *Eudyptula albosignata* Finsch, to show the temporal fossa, the slightly curved quadrato-jugal bar, and the dentary suture of the mandible.
- Fig. 2. The skull of *Catarrhactes chrysocome* Forst., to show the temporal fossa, the size of the squamoso-parietal wings, the great curvature of the quadrato-jugal bar and of the dentary suture of the mandible.
- Fig. 3. The skull of *Megadyptes antipodum* Homb. & Jacq., for comparison with that of *Catarrhactes*, to show the greater size of the temporal fossa and squamoso-parietal wings and the more slender jaws.

PLATE LXI.

Additional letters.

<i>als.</i> = alisphenoid.	<i>j.</i> = jugal.
<i>ang.</i> = angulare.	<i>max.</i> = maxilla.
<i>ar.</i> = articulare.	<i>mes.</i> = mesethmoid.
<i>ant.b.f.</i> = anterior basicranial fontanelle.	<i>op.</i> = opisthotic.
<i>b.oc.</i> = basioccipital.	<i>p.</i> = parietal.
<i>bt.pl.</i> = basitemporal plate.	<i>par.</i> = parasphenoid.
<i>b.s.</i> = basisphenoid.	<i>pro.</i> = proötic.
<i>cor.</i> = coronoid.	<i>s.a.</i> = supra-angular.
<i>d.</i> = dentary.	<i>s.o.</i> = supra-occipital.
<i>ep.o.</i> = epiotic.	<i>sp.</i> = splenial.
<i>ex.</i> = exoccipital.	<i>sq.</i> = squamosal.
<i>fr.</i> = frontal.	<i>v.</i> = vomer.
<i>h.pt.</i> = hemipterygoid.	

The Skull of the Nestling.

- Fig. 1. Inner view of a longitudinal section of the skull of a nestling *Catarrhactes chrysocome*, showing the unclosed sutures.

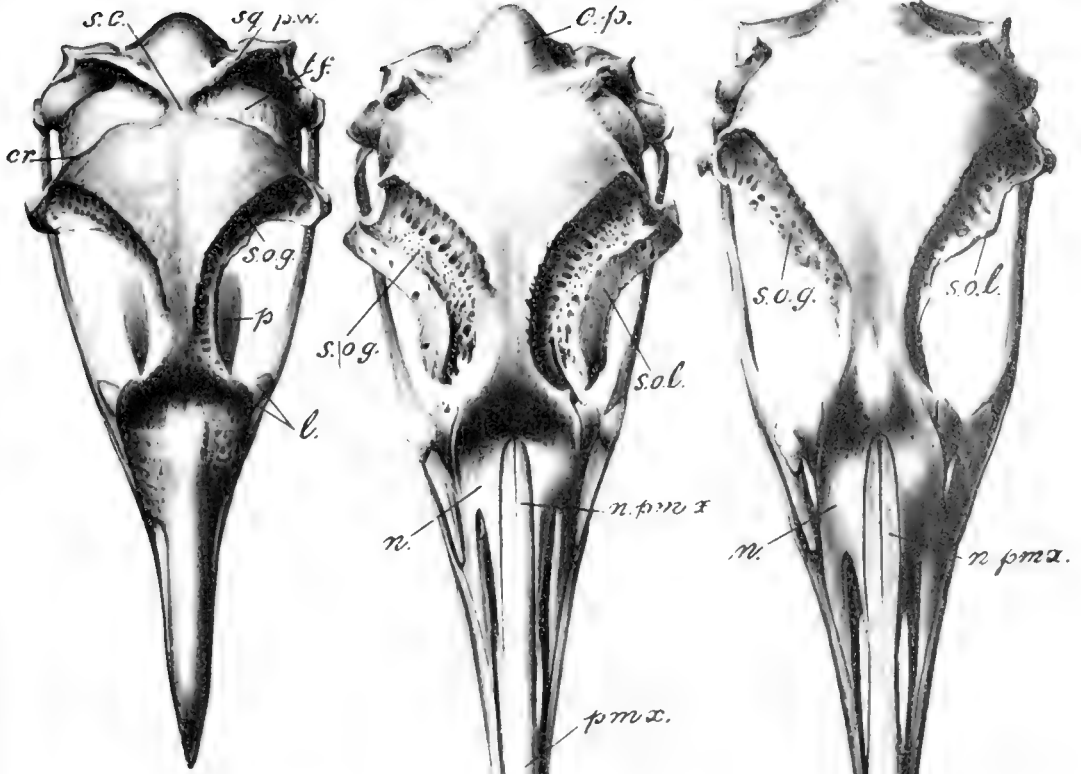

Fig 1.

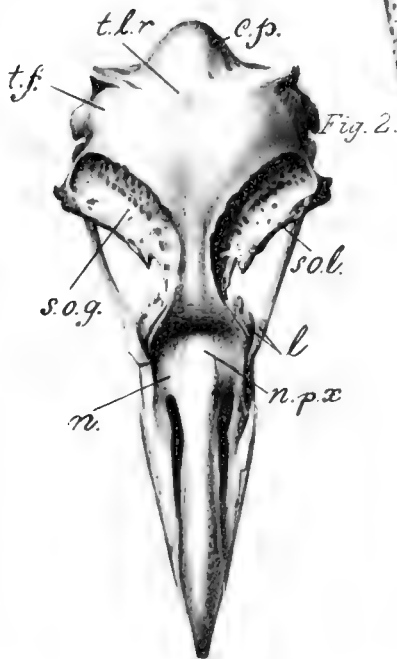

Fig. 2.

Fig. 3.

Fig 5.

Fig. 4.

OSTEOLOGY OF THE IMPENNES

1. *Spheniscus magellanicus* Fig. 2. *Pygoscelis papua*. Fig. 3. *Aptenodytes patagonica*.
 Fig. 4. *Eudyptula albosignata* Fig. 5. *Catarrhactes chrysocome*.



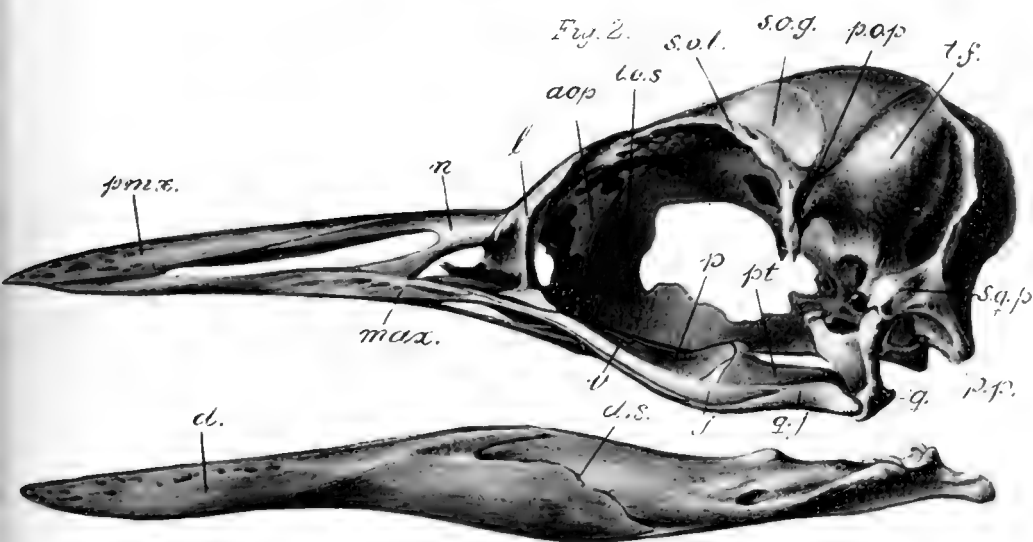
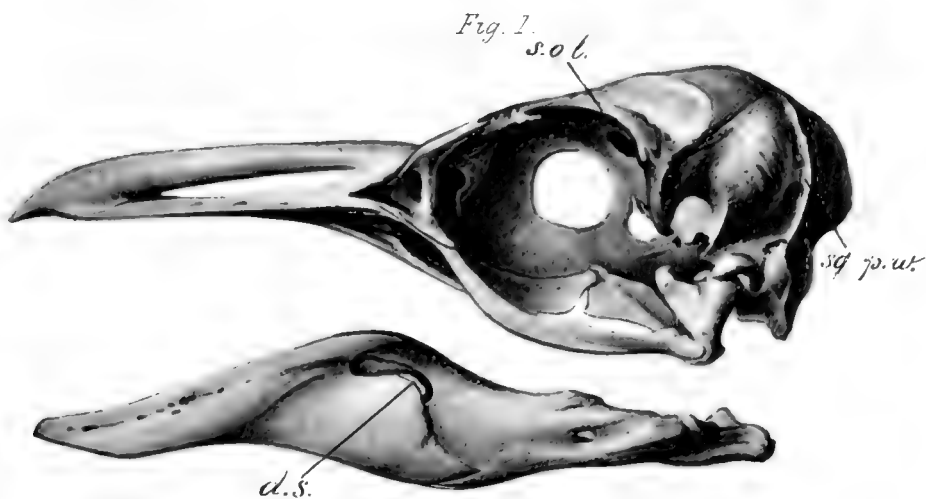
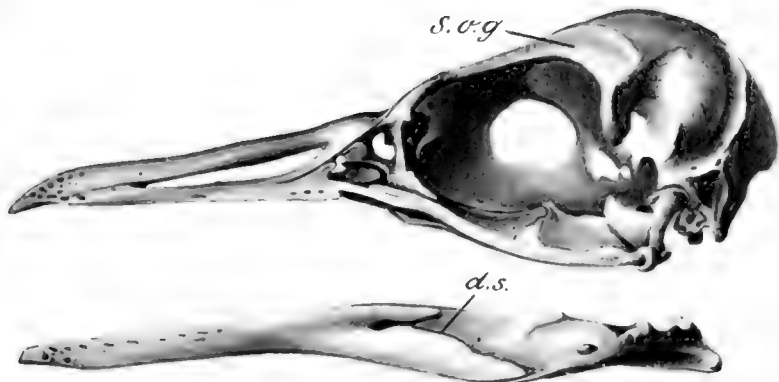
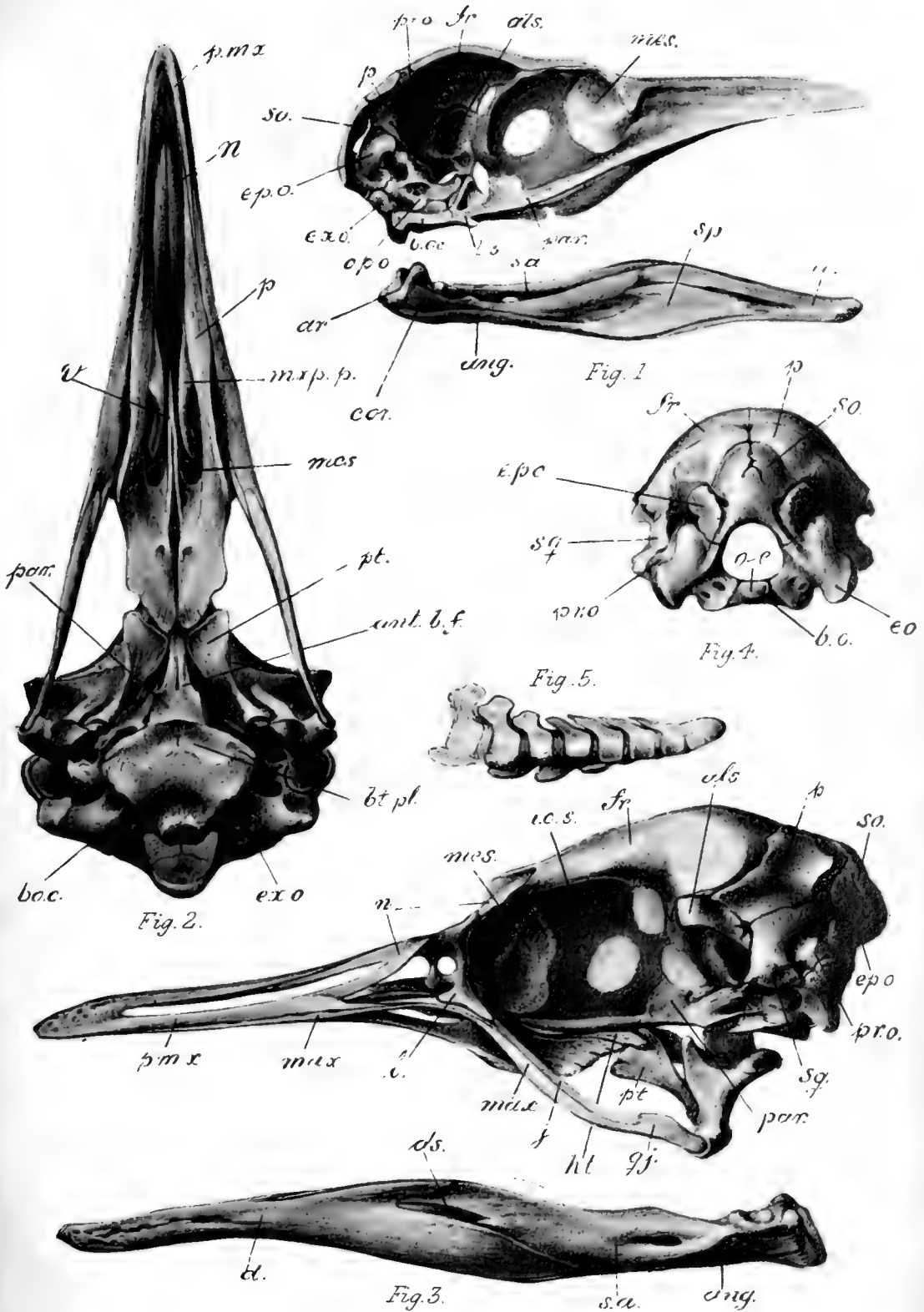

Fig. 3.

OSTEOLOGY OF THE IMPENNES

Fig. 1. *Eudiptula albosignata* Fig. 2. *Catarrhactes chrysocome*.
Fig. 3. *Megadyptes antipodum*.





OSTEOLOGY OF THE IMPENNES.

Figs. 1.4.5. *Catarrhactes chrysocome*. Figs. 2.3. *Fygoscelis papua*.



- Fig. 2. Ventral view of the skull of a young *Pygoscelis papua*, showing the unclosed sutures, the anterior basicranial fontanelle, and basi-temporal plate of the parasphenoid.
- Fig. 3. Lateral view of the outer side of the skull; note especially the great distinctness of the squamosal, the prootic and epiotic, the parasphenoid, and the hemipterygoid.
- Fig. 4. Skull of a nestling *Catarrhactes* seen from behind. To show the paired supra-occipital, the exoccipital, and epiotic.
- Fig. 5. Pygostyle of a nestling *Catarrhactes chrysocome*, showing the separate vertebræ, which later fuse and make up the "pygostyle."

3. Note on an Anthropoid Ape. By W. L. H. DUCKWORTH, M.A., Fellow of Jesus College, Cambridge.

[Received December 13, 1898.]

The specimen under consideration, which is an aged female, was shipped to this country from the Gaboon River, West Coast of Africa. In placing on record the results of the dissection of this anthropomorphous ape, I am met with the difficulty of being unable to refer to it with confidence as either a true Champanzee (*Anthropopithecus troglodytes*) or a genuine Gorilla (*A. gorilla*).

In a communication to the section of General Zoology at the International Congress recently held at Cambridge, I was able only to mention the difficulty, and time did not allow of any discussion on the subject. I have therefore ventured to return to this in rather greater detail, and hope that I may be favoured with some advice thereupon.

I turn at once to the characters of our specimen, and, to summarize these characters in the briefest manner, would note the general size and bulk (stature nearly 1200 mm.). The loss, consequent on the inadequate method of preservation employed, of almost all the hair, shows that the colour of the skin is grey, with black patches where the epidermis is retained, the face and the dorsal aspects of digits being of the latter colour. The hip- and knee-joints are much more extensible than in most specimens of the Anthropoid Apes; the limbs and extremities are distinctly slender.

The ears are remarkably asymmetrical, the upper half of the right ear being absent. This is probably the result of a bite; a similar condition is present (on the same side) in a Chimpanzee in the Zoological Museum at Leipzig.

On its arrival the specimen was thought to be a female Gorilla, the principal reasons, so far as I can ascertain, for the opinion being the facts of its great bulk and the dark colour of the face and extremities. But from the first time I saw it, I have had misgivings about the correctness of this view, and these up to a certain point have been strengthened by further observations.

These doubts were raised by the following features presented by the specimen:—

1. The large size of the ear.—Gorillas have usually small ears.
2. The comparative lack of supra-orbital prominence.—This is marked even in female Gorillas.

3. The comparative breadth of the interorbital space; which is great when compared to that of many Gorillas.
4. Characters of the upper lip: the great distance from the base of the septum nasi to the margin of the lip; and the absence of the median furrow which is so marked in many Gorillas.
5. The slenderness and narrowness of hand and foot.
6. The relatively great development of pollex and hallux.
7. The small size of the teeth; these are much worn, the third molars the least; there are indications that, originally, four cusps were present in the upper molars. As regards the lower molars, those of the third pair show comparatively little wear, and have three large and two subsidiary cusps.
The average transverse diameter of the crowns of the molar teeth is 10·4 mm. as against 14 mm., which is the corresponding average in the skull (at Cambridge) of an undoubted female Gorilla. [*Cf.* Table I. *infra.*]
8. Muscular system. A plantaris muscle is present in the right lower extremity. I cannot find any record of this in a Gorilla up to the present.

TABLE I.—*Dimensions of Teeth* (in millim.).

Molar.		"A."		Gorilla, ♀. Skull at Cambridge.	
		A.P.	T.	A.P.	T.
Upper	1 R.	9·5	10·5	12	13·5
	2 "		12	14	14
	3 "		10·5	13	14
	1 L.	10	10	12	14
	2 "		11	15	15
	3 "		10·5	15	14·5
Lower	1 R.		9·5	12	?
	2 "		11	15	14
	3 "		9·5	17	14·5
	1 L.		9·5	12·5	12·5
	2 "		11	15·5	14
	3 "		10	17	14

A.P. = Antero-posterior, T. = Transverse diameter of crown of molar.

These are the principal points to which one refers in attempting to assign the creature to a recognized species; and, in my opinion, they indicate that this specimen is more correctly designated a Chimpanzee than a Gorilla. The hair is so scanty as to afford no reliable evidence on the subject.

I have been led from this case to collect some illustrations and descriptions of some of the Anthropoid Apes which have in former years presented difficulties when the determination of their species for descriptive purposes came into question.

The accompanying diagram (p. 991), in which, however, the

outlines are carefully traced from photographs, will serve to recall some of those specimens. I would direct somewhat special notice to the representation of "Johanna," the large ape at Messrs. Barnum and Bailey's World's Show. I have made some measurements of this animal, and hope to be permitted to communicate them at a future meeting.

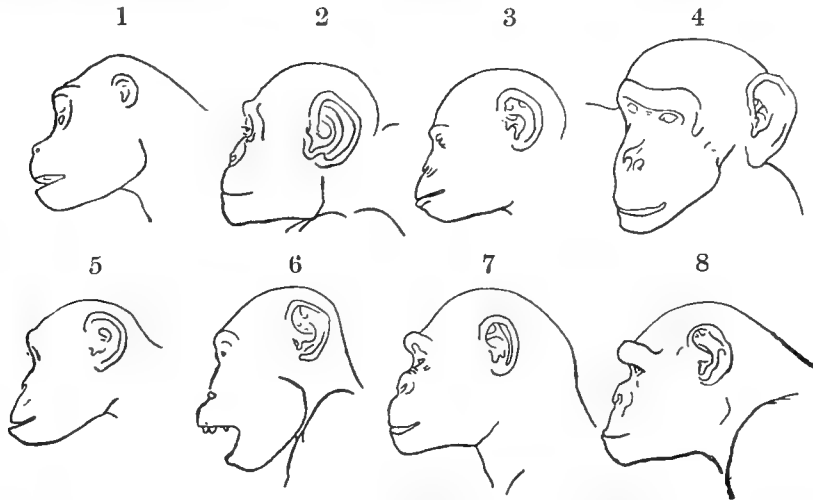

Outline tracings of the heads of various Apes.

- No. 1. Head of a female Gorilla, a stuffed specimen in the Natural History Museum at Hamburg.
- No. 2. Head of a Chimpanzee with ears of considerable size.
- No. 3. Head of a Chimpanzee with smaller ears.
- No. 4. Head of Johanna: from a photograph of the living animal.
- No. 5. Head of the Ape "A," at Cambridge.
- No. 6. Head of Aubry's Chimpanzee: from the illustration in the original memoir, 'Nouvelles Archives du Muséum.'
- No. 7. Head of an Ape described by Hartmann in the 'Archiv für Anatomie,' 1876. In Hartmann's paper it appears as No. 1 in the illustrations, and is therefore referred to as Hartmann's example No. 1. The figures Nos. 2 & 3 of the present illustration are taken from the same communication by Hartmann.
- No. 8. Head of Mafuka: from Mützel's drawing.

In studying the creatures represented in the diagram, I paid special attention to certain facial features, and in fact, with two exceptions (Nos. 3 & 4), all the examples are drawn to scale in such a way that the facial length is constant throughout the series—a method of illustration which possesses obvious advantages in enabling comparisons to be made. The variety of profile met with in these animals is the principal point illustrated by this diagram.

I next proceeded to consider measurements of the face and ears, the data being represented in Table II. (p. 992) and being provided by records (in the cases of specimens "Au.," "Maf.," "Lüb. H.," "Lüb. W.," and "Den."), by spirit-specimens (viz., "B.," "A.," "Cy.," "Cr.," "H.," "F.," all at Cambridge), by "Johanna," and by a stuffed specimen at Hamburg ("Hamb.").

TABLE II.—Measurements (in millim.).

	Specimens.											
	♂ "B."	♀ "A."	♀ "Au." "Joh."	♀ "Maf."	♀ "Hamb." "Lüb.H."	♀ "Lüb.W."	♂ "Cy."	♂ "H."	♂ "Cr."	♂ "F."	♀ "Den."	
Sex	♂	♀	♀	♀	♀	♀	♂	♂	♂	♂	♀	
Supra-orbital ridge to lip-margin	62	118	104	(12.5)	130	72	65	12	23.5	
Lowest part of septum nasi to lip-margin	22	42	40	(6)	30	15	13	3	8	
Upper labial index = Index 1	35.5	35.6	38.4	(48)	? 38	...	23	20.8	20	25	34	
Interlacrymal diameter	20	31	34	(5.5)	34	21	15	6	12	
Rictus oculi	15	23	23	(3.25)	35	21	17	6	11	
Interorbital index = Index 2	40	40.3	42.5	(45.8)	? 46	...	33.6	33.3	30.6	33.3	35.3	
Ear: breadth	48	48	50	55	45	33	34	32	31	35	10	
Ear: height	62	71	68	60	70	47	51	47	41	6	16	
Superficies of Ear as represented by the } product of Breadth and Height	2976	3408	3400	3300	3150	1551	1734	1504	1271	21	160	

"B." Chimpanzee, Cambr. "A." The specimen described herein, Cambr. "Au." Aubrey's Chimpanzee. "Joh." Johanna. "Maf." Matuka. "Hamb." Gorilla ♀, Hamburg. "Lüb. H." Gorilla ♀, Lübeck. "Lüb. W." Gorilla ♀, Lübeck. "Cy." Gorilla ♂, Cambr. "H." Gorilla ♂, Cambr. "Cr." Gorilla ♂, Cambr. "F." Gorilla fetus, Deniker. The last eight of these are undoubted Gorillas, "H." & "Cr." being immature. From "Johanna" only the ear measurements could be obtained directly, the others are taken from a photograph.

The features more specially observed were:—the total facial length and the part contributed to it by the upper lip; the inter-orbital and biorbital diameters, and the dimensions of the ears. Of these dimensions I have constructed indices (Tab. II.); and a comparison of the members of this group as arranged in the numerical order of the indices is here presented (Tab. III.).

TABLE III.—*Specimens in Numerical Order.*

Index 1.	Index 2.	Superficies auris.
"Johanna."	"Johanna."	Cambr. specimen "A."
Aubry's Chimpanzee.	Aubry's Chimpanzee.	Aubry's Chimpanzee.
Cambridge specimen "A."	Cambridge specimen "A."	"Johanna."
Chimpanzee "B."	Chimpanzee "B."	"Mafuka."
Deniker's Gorilla.	Deniker's Gorilla.	Chimpanzee "B."
Cambridge Gorilla "F."	Cambr. Gorilla "Cy."	Cambr. Gorilla "Cy."
" " "Cy."	" " "H."	Hamburg Gorilla.
" " "H."	" " "F."	Cambr. Gorilla "H."
" " "Cr."	" " "Cr."	(? Lübeck Gorilla "H.")
		Cambr. Gorilla "Cr."
		(? Lübeck Gorilla "W.")

$$\text{Index 1. } \frac{\text{Height of upper lip} \times 100}{\text{Distance supra-orb. crest to lip-margin}}$$

$$\text{Index 2. } \frac{\text{Interorbital diameter} \times 100}{\text{External biorbital diameter}}$$

Thus arranged, it is to be observed that the Chimpanzee-like or "intermediate" apes keep on the whole fairly closely together and away from the genuine Gorillas that I have been able to measure—the Chimpanzees furnishing the higher, and the Gorillas the lower terms of the series in the case of each index.

In these respects, too, the position of "A" is evidently rather with the Chimpanzees than with the Gorillas.

In the last table (Tab. IV.) I have presented some other

TABLE IV.

	"A."	Cy.	H.	Cr.	"Joh."
Sitting height	737	836	?	340	830
Palmar breadth	76	106	56	48	?
Pollex	60	24	22	17	?
Hallux	75	71	47	22	?
Length of pes	240	282	142	110	235
" humerus	293	360	170	128	270
" radius	252	345	175	115	305
" femur	260	290	? 175	90	360
" tibia.....	250	270	140	94	260
Index—Radio-humeral ...	85.3	95.8	102.9	89.8	? 112.8
" Tibio-femoral ...	96.0	93.1	? 80	104.5	72.3
" Humero-femoral.	112.7	124.1	? 97.1	142.3	75
" Intermembral ...	107	125.9	? 109.2	132.1	92.7

dimensions (in millim.) of the Ape "A," together with the corresponding figures relating to three undoubted Gorillas at Cambridge, two of which, however, are immature. And I have added the corresponding figures for "Johanna" for the sake of comparison. Three indices show marked contrasts between "A" and undoubted Gorillas.

In comparing "A" with undoubted Gorillas, one may also specially remark the palmar breadth: this is very much less than in a Gorilla at Cambridge of rather greater size, viz. "Cy," whereas the pollex in "A" is much longer than in this Gorilla.

After ascertaining, however, that, from evidence supplied by teeth, by facial features, and by the extremities, our specimen "A," while in some respects intermediate, yet resembles the Chimpanzee rather than the Gorilla, it is not encouraging to find Hartmann in 1876, after an extended series of observations, pronouncing on none of these characters as really of specific import. Thus he states¹, for instance, that whereas in Chimpanzees large ears are the rule, yet individuals with small ears are not unknown, and in fact he illustrates this (see fig. 3, p. 991); whereas again in Gorillas, though small ears are usual, one sometimes finds examples in which these appendages are of large size.

But yet on finding the coincidence of so many characteristics of Chimpanzee as in this animal, one may well be excused hesitation in continuing to regard the specimen as a Gorilla.

However, it can hardly be described as an ordinary example of *Anthropopithecus troglodytes*; and I am inclined to think, in the absence of contradictory evidence, that we have here a specimen of Du Chaillu's Kooloo-Kamba. Its great size gives it some claim to an intermediate position between *A. troglodytes* and *A. gorilla*.

But if an intermediate form, it differs appreciably from members of another group of intermediate forms which we may call the Mafuka group, and which is constituted by Mafuka, Johanna, and Hartmann's example No. 1 (cf. fig. 7, p. 991).

4. On the Turbinolid and Oculinoid Corals collected by the Author in the South Pacific². By J. STANLEY GARDINER, M.A., Gonville and Caius College, Cambridge.

[Received November 15, 1898.]

(Plate LXII.)

Genus RHIZOTROCHUS.

Rhizotrochus, Milne-Edwards & Haime, Cor. ii. p. 97.

In dredging on the outer slopes of the reef at Funafuti I never obtained any solitary corals. Mr. Hedley, however, found one

¹ Zeitschrift für Ethnologie, 1876.

² Communicated by W. BATESON, F.Z.S. For previous papers on the Corals, see P. Z. S. 1897, p. 941, and 1898, pp. 257, 525.

specimen, which has been identified by Whitelegge with *Caryophyllia clavus*. The specimen referred to this genus was dredged by the 'Penguin,' between 150 and 105 fathoms, and found by me on one of the stones brought up.

1. RHIZOTROCHUS LEVIDENSIS Gardiner.

Rhizotrochus levidensis, Gardiner, Willey's Zoological Results, pt. ii. p. 162, pl. xix. fig. 2 (1898).

The specimen of this species obtained by me differs slightly from the type specimen in the Willey Collection. The outside is not nearly so much overgrown by organisms, and there is one large central radicle and six smaller rootlets. The calice is rounder, and the epitheca and septa are thinner and more delicate. The primary septa do not run almost horizontally inwards directly from the edge of the epitheca as in the type, but form thin vertical lines on the epitheca for about 1 mm. below its edge and then abruptly broaden. These characters may very probably be due to a quicker growth, or to the greater depth, the type specimen being dredged from 40 fathoms.

Funafuti; 105 fathoms, outside the reef.

Genus STYLOPHORA.

Stylophora, Milne-Edwards & Haime, Ann. des Sc. Nat. sér. 3, t. xiii. p. 102, and Cor. ii. p. 133.

I have referred the specimens of this genus to eight species, of which I consider four to be new. The genus occurs locally in great abundance on the rim of the reef, where the sea breaks. It is very rare in the lagoon, and was only noted by me on certain shoals near passages in the reef. The colour of the living colonies usually varies from a distinct brown to a light yellow.

The specific characters in the genus are extremely unsatisfactory, and at first sight I was inclined to refer my collection, consisting of only a few specimens, to two or three species. A careful comparison, however, with a small number of specimens in the Cambridge Museum, and subsequently with the British Museum collection, showed me that there were a number of very distinct types. The shape and mode of branching of the colonies is not generally of much specific value, being, I consider, very largely dependent on the position of growth. I have hence relied mainly on the characters of the corallites—the shape and appearance of the lip if present, the arrangement of the septa and columella, &c. These characters, while usually varying largely with the position of the calices in the corallum, are fairly constant, and I have in all cases noted them for the terminal and side calices of the branches.

The development of the cœnenchyma between the calices usually increases gradually from the ends to the bases of the branches. The septa, too, gradually get thicker, and the calices often decrease somewhat in size, apparently owing to a deposition of skeleton within the calice-walls.

2. *STYLOPHORA FLABELLATA* Quelch.

Stylophora flabellata, Quelch, 'Challenger' Report on Reef-Corals, p. 54, pl. ii. figs. 1-1 b (1886).

I have referred to this species two small fragments which correspond very closely to the 'Challenger' specimen in the British Museum.

Funafuti; lagoon, 8 fathoms.

3. *STYLOPHORA DIGITATA* Pallas.

Madrepora digitata, Pallas, Elench. Zooph. p. 326 (1766).

Stylophora digitata, Klunzinger, Die Korallthiere des Rothen Meeres, Th. ii. p. 61, pl. vii. fig. 5 and pl. viii. fig. 1.

I have referred to this species a clump, 10 cm. high by 14 cm. broad, which corresponds fairly well to Klunzinger's description. The cœnenchyma is covered with long pointed spines which on the sides of the branches project, especially on the theca over the calice, forming a moderately acute prominence or lip. At the ends of the lower branches the theca projects equally around each calice, but the terminal calices of the longer branches are more or less polygonal and separated only by a thin wall, the fused theca, without any cœnenchyma. The specimen was living at the extreme edge of the reef, and it is probable that the longer branches had reached the low-tide level and were unable to grow further. Some, too, show a slight tendency to broaden out at their ends.

There are in the terminal calices of the branches six distinct, smooth, thin septa, which fuse below with the small, styliform but prominent columella. In the side calices of the branches the primary septa are always distinct and similar, but the columella can seldom be seen.

Funafuti; outer reef.

4. *STYLOPHORA SEPTATA*, n. sp. (Plate LXII. fig. 1.)

The specimen is a colony, about 9 cm. in diameter by 6 cm. high, of the general form of *S. digitata*, consisting of a number of branches arising from a common base. The branches are somewhat fused below but free above, ending usually in two or three small lobes 8-14 mm. in breadth by 4-6 mm. thick.

The terminal calices of the branches are very crowded together, and there is between them no development of cœnenchyma, which is, however, well formed between the side calices. The latter are about .9 mm. in diameter and there are generally 4 in 5 mm. The upper wall of these calices projects usually for about 1 mm. into an obtuse lip, which is on the outside, as also is the cœnenchyma between, covered with short, rough, granular spines, which are often much compressed and arranged in striæ.

The calices of the ends of the branches are very deep, with the six primary septa well developed and with rough edges; they are prolonged deep down in the cell to meet a very delicate style-like projecting columella. The secondary septa between are distinct,

but little projecting and very thin, while the tertiary septa are indicated by long flattened spines at the edges of the calices. The calices of the sides of the branches have the primary septa very thick and rough at the edges and sides, while the secondary septa are much broader than in the terminal calices, and the tertiaries are generally distinct; the columella is situated low down in these calices, but can usually be distinguished as a broad, rough, slightly projecting mass, in the lowest calices much more prominent.

Rotuma; outer reef.

This species is evidently very closely allied to *S. digitata*, having almost precisely the same mode of growth, and may perhaps be only a variety of it due to a very slow growth owing to its position on the reef or some other cause. However, the presence of twelve distinct septa in nearly all the calices and a very obtuse lip are constant features of difference.

5. *STYLOPHORA COMPRESSA*, n. sp. (Plate LXII. fig. 4.)

Corallum consisting of much compressed, dichotomously branching stems, which broaden out towards their extremities, where they bear a number of small lobes. The latter are generally from 1–2 cm. long, and are usually flattened at right angles to the compression of the branches which bear them; they further, too, arise almost invariably in the same plane. Some of the branches immediately below these lobes are 5 cm. in breadth by about 1 cm. in thickness, and the lobes are generally 1–2 cm. broad by about 6 mm. thick.

The upper edges of the side calices of the branches are generally well developed, 1 mm. long, and rather acute in shape; on the ends of the branches and near the attached base there is, however, no such development. The cœnenchyma is everywhere well developed except between the end calices of the branches; its surface is covered with low blunt granular spines, which may form striations on the lips of the corallites. The calices are about 1 mm. in diameter, and there are on the sides of the branches usually 7 in 1 cm.

The terminal calices of the branches have the primary septa projecting considerably, rough-edged and prolonged below to meet the small, style-like, very prominent columella; the secondary septa are also present as thin, narrow, but distinct lamellæ. In the side calices of the branches both primary and secondary septa are thicker and slightly exsert; the tertiaries, too, can be distinguished by their spinulous upper ends, but within the calices are indistinct. The columella, however, is thicker and less prominent. Towards the base of the colony the septa become less exsert; the primaries are especially broadened and thickened, and the columella is a very well-marked style.

Funafuti; outer reef and 5 fathoms. Two specimens.

The reef specimen has its septa rougher and with more granular sides than the dredged one; the columella, too, is larger and less style-like. Some of the branches approach in form to those of

S. palmata, but the corallites generally have their upper edges projecting and acute.

6. *STYLOPHORA RUGOSA*, n. sp. (Plate LXII. fig. 3.)

Corallum consisting of more or less rounded branches, which at their summits break up into a number of somewhat compressed lobes. The branches have a diameter of about 2.2 cm. about 5 cm. below their apices, while the lobes above are 2 to 3 cm. high, up to 3 cm. broad by about 1 cm. thick.

On the sides of the branches the upper edges of the calices are exceedingly well developed, forming very acute prominent lips about 1.1 mm. long. The cœnenchyma is everywhere well developed except between the terminal calices of the branches; its surface is covered by low blunt granular spines, which may be very elongated on the edges of the lips of the calices. The calices are very deep, about 1.2 mm. in diameter, and on the sides of the branches usually 3 in 5 mm.

The primary septa of the terminal calices of the branches are usually very thin and smooth, fusing below with the thin prominent styliform columella. In the side calices the primary septa are thicker and rougher, but do not generally project far, nor can the columella usually be distinguished. There are no distinct secondary and tertiary septa projecting into the calices, but their positions are indicated by larger and smaller flattened spinulous projections between the prominent upper edges of the primary septa, giving to the lower calices of the stems the appearance as of a raised edge.

Funafuti; outer reef. Rotuma; outer reef. Two specimens.

There are considerable differences between the two type specimens. The lips of the calices are more elongated and broader in the Funafuti specimen, while the calices themselves are more crowded and slightly larger; the whole corallum, too, is much less heavy. These differences are, however, I think, due to its more vigorous and healthy growth. The corallum of the Funafuti specimen is almost free from boring organisms, while it is in the Rotuman colony bored through and through by *Clione* and annelids.

The fractured surface of the Funafuti specimen shows very well the mode of growth. The separate polyp-tubes can be seen running at first almost vertically in the centre of the corallum, but later turning abruptly outwards, after which they do not increase in size. Fresh polyp-tubes can be seen to be budded off at their sides, and have from the first almost the size of the adult polyp. The tabulæ are very well-marked and occur in the tubes at regular intervals of about .5 mm.

7. *STYLOPHORA PISTILLATA* Esper.

Stylophora pistillata, Esper, Pflanz. t. i. p. 73, Madr. pl. 60 (1767).

Stylophora pistillata, Klunzinger, Die Korallthiere des Rothen Meeres, Th. ii. p. 62, pl. vii. fig. 3, pl. viii. fig. 2.

There is one small specimen, which corresponds closely to this species, which has been excellently described by Klunzinger. The surface of the cœnenchyma is covered by low rough spines. The septa and columella closely resemble those of *S. digitata*, but are somewhat rougher. At the ends of the branches, between two of the lobes, the upper wall of the calice is often more projecting and somewhat pointed, while generally it is low and vaulted. The specimen is rather more massive with broader and thicker branches than those in the British Museum.

Funafuti; outer reef.

8. *STYLOPHORA PALMATA* Blainville.

Stylophora palmata, Blainville, Dict. des Sci. Nat. t. lx. p. 360 (1830); Man. p. 384.

Stylophora palmata, Klunzinger, Die Korallthiere des Rothen Meeres, Th. ii. p. 62, pl. vii. fig. 6, pl. viii. fig. 11.

There are two specimens, which cannot be separated from this species, though neither show any trace of the anastomosis of their branches, which, however, can scarcely be a feature of specific value. The one specimen is a branch 8 cm. high, which at the base is compressed and 3 cm. in breadth; above it divides up into a number of very compressed lobes, 2 to 5 cm. in breadth by about 8 mm. thick. On the sides of the branches there are seven coralites in 1 cm.; the primary septa are distinct, with generally rather rough sides and spinulous edges. The columella cannot usually be distinguished except in the apical calices, where it is smooth and styliform.

The second specimen (dredged from 30 fathoms) closely resembles the first; the calices of its base are very small, and the cœnenchyma between is strongly developed. When first obtained it was of a green colour, while the species is generally light brown.

Funafuti; outer reef and 30 fathoms.

9. *STYLOPHORA LOBATA*, n. sp. (Plate LXII. fig. 2.)

Corallum consisting of low clumps of thick, often somewhat compressed branches, dividing dichotomously above into low, broad, blunt lobes.

The upper margin of the calice is in places prominent and may be acute or vaulted, but usually the whole edge of the calice projects in a ring-shaped form. The cœnenchyma, except at the base of the colony, is not nearly so well developed as in most species; its surface is everywhere covered by low spines, arranged in striæ around the calices. The calices are 1-1.3 mm. in diameter and there are generally four in a space of 5 mm. The terminal calices of the branches are not crowded and have the cœnenchyma almost equally well developed between them.

The primary septa are distinct, broad, rough lamellæ, which fuse low down in the calice with the broad, low columella, which is

never prominent; the secondary septa are very little projecting, but can usually be distinguished. The raised rims of the calices show much flattened spines, which correspond to the primary, secondary, and tertiary septa.

Funafuti; outer reef. Three specimens.

This species resembles *S. palmata* in form, but shows no sign of an anastomosis of its branches. The raised character of the whole edge of the calice separates the species from all previously described forms. In places the upper edge of the calice may be somewhat vaulted or even slightly acute, but the whole lip is never as large or distinct as it generally is even in *S. palmata*.

EXPLANATION OF PLATE LXII.

Fig. 1. *Stylophora septata*, $\times \frac{2}{3}$, p. 996.

Fig. 2. *Stylophora lobata*, $\times \frac{2}{3}$, p. 999.

Fig. 3. *Stylophora rugosa*, $\times \frac{2}{3}$, p. 998.

Fig. 4. *Stylophora compressa*, $\times \frac{2}{3}$, p. 997.

5. On some Crustaceans from the South Pacific.—Part III.
*Macrura*¹. By L. A. BORRADAILE, M.A., F.Z.S.,
Lecturer in Natural Sciences at Selwyn College, Cambridge.

[Received November 15, 1898.]

(Plates LXIII.—LXV.)

The specimens described in the present paper were collected by Mr. J. Stanley Gardiner in the Islands of Funafuti (Ellice Group), Rotuma, and Viti Levu, Fiji. Mr. Gardiner has very kindly furnished me with notes respecting several of them.

The Funafuti collection contained examples of the following species:—

1. ? *Periclimenes danæ* (Stimpson).
2. *Coralliocaris brevirostris* Borradaile.
3. *Palæmonella tridentata*, n. sp.
4. *Saron marmoratus* (Olivier).
5. *Athanas sulcatipes*, n. sp.
6. *Alpheus strenuus* Dana.
7. *Alpheus parvirostris* Dana.
8. *Alpheus collumianus* Stimpson.
9. *Alpheus levis* Randall.
10. *Alpheus frontalis* Say.
11. *Alpheus prolificus* Bate.
12. *Alpheus funafutensis*, n. sp.
13. *Metabeteus minutus* Whitelegge.
14. *Callianidea typa* H. M.-Edwards.

¹ For Parts I. and II., see P. Z. S. 1898, pp. 32 and 457.

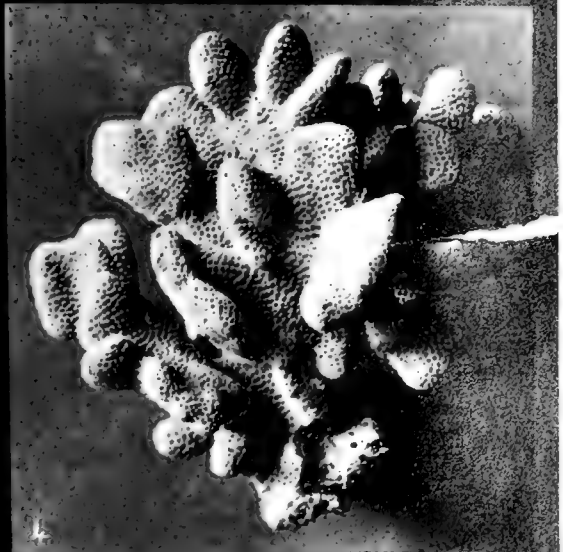
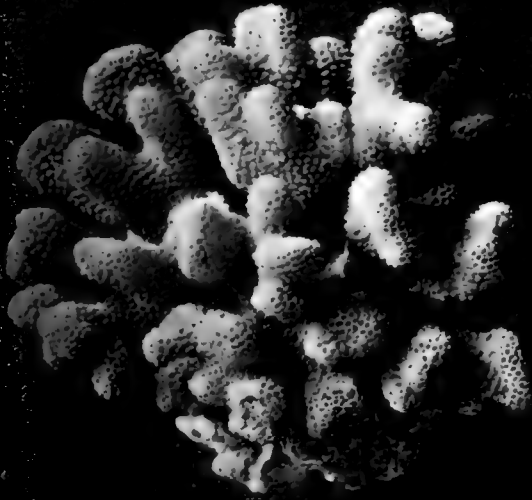

Photomicro by Bale & Danielsson, Ltd.



In the Rotuma collection were:—

1. *Metapencæus commensalis*, n. sp.
2. *Stenopus hispidus* (Olivier).
3. *Periclimenes spinigerus* (Ortmann).
4. *Periclimenes rotumanus* Borradaile.
5. *Conchodytes meleagrince* Peters.
6. *Saron marmoratus* (Olivier).
7. *Alpheus strenuus* Dana.
8. *Alpheus macrochirus* Richters.
9. *Alpheus levis* Randall.
10. *Alpheus frontalis* Say.
11. *Alpheus pachychirus* Stimpson.
12. *Alpheus gracilipes* Stimpson.
13. *Paribacus antarcticus* (Rumph.).
14. *Panulirus penicillatus* (Olivier).
15. *Callianidea typa* H. M.-Edwards.

From Fiji are:—

1. *Caradina wycki* Hickson.
2. *Caradina vitiensis*, n. sp.
3. *Periclimenes vitiensis* Borradaile.
4. *Palæmon lar* Fabricius.
5. *Palæmon* sp.

I proceed to the consideration of the several species.

Tribe PENÆIDEA.

Family PENÆIDÆ.

Subfamily PARAPENÆINÆ.

Genus METAPENÆUS W.-Mason & Alcock, 1891.

1. METAPENÆUS COMMENSALIS, n. sp. (Plate LXIII. figs. 1-1b.)

Definition:—“ A *Metapencæus* with the rostrum straight, bearing 8 teeth above and none below, fringed underneath with long hairs, and reaching to the middle of the second joint of the peduncle of the first antenna; carapace bearing a median spine at the base of the rostrum, and infraorbital, hepatic, and pterygostomial spines; first antenna with the penultimate joint of the peduncle longer than the last joint, flagella subequal (?), not so long as the last two joints of the peduncle (?); second antenna with the scale almost as long as the peduncle of the first antenna; third maxilliped reaching the end of the first joint of the peduncle of the first antenna; first pair of legs rather stout, with somewhat swollen chelæ, not reaching end of ante-penultimate joint of third maxilliped; second and third pairs more slender, with elongate chelæ, second reaching middle of penultimate joint of third maxilliped; third exceeding third maxilliped; fourth and fifth pairs subequal, reaching middle of wrist (carpopodite) of third pair; in all

the legs the carpus the longest joint; without a rudiment of the anterior arthrobranch on the fourth leg (?); with the right side of the petasma longer than the left; fifth and sixth abdominal segments with well-marked dorsal keel, fourth and fifth segments ending in two spines, sixth in one spine; telson elongate, triangular, ending in a point, and armed on each side with four spines, of which the last but one is the longest, while the most anterior is the smallest and the most distant from the rest."

Length of present specimen 42 mm. from tip of rostrum to end of telson.

The inner flagellum of the first antenna appears to be broken off near the tip on each side.

The systematic position of this species must remain somewhat doubtful till the collection of a series of specimens shall render it possible to decide the branchial formula. So far as could be ascertained without considerable injury to the single specimen, this is identical with that given by Wood-Mason and Alcock [Ann. Mag. N. H. (6) viii. p. 273 (1891)] for *M. coniger*, with the exception of the absence of the rudiment of an anterior arthrobranch on the fourth leg. This, however, is also wanting in *M. rectacutus* (Bate). The nearest ally of the new species would appear to be *M. philippinensis* (Bate) ['Challenger' Macrura, p. 261]; from which, however, it differs in having an additional tooth on the rostrum, in the length of that organ and of the antennal scale, in having the right, and not the left, side of the petasma the longer, and in the absence of the rudiment of an anterior arthrobranch on the seventh thoracic segment.

The living animal is almost transparent, with two or three bright pink bands. Its habits are most interesting. Mr. Gardiner found it living in the stomodæum of a green and yellow actinian, 14 cm. broad, allied to *Discosoma haddoni*. Also commensal in the same actinian was a small fish with bright red and yellow bands, identified by Mr. Boulenger as *Coris greenoughi*.

One male specimen from Rotuma.

Tribe STENOPIDEA.

Family STENOPIDÆ.

Genus STENOPUS Latreille, 1825.

2. *STENOPUS HISPIDUS* (Olivier), 1811. (Plate LXIII. figs. 2*a*, 2*b*.)

Palæmon hispidus, Olivier, Encycl. viii. p. 666 (1811).

Stenopus hispidus, Latreille, Desmarest's Consid. sur les Crust. p. 227 (1825); H. M.-Edwards, H. N. Crust. ii. p. 407 (1837); id. Cuvier's R. An. 3rd ed., Crust. p. 137, pl. l. fig. 2; Dana, U.S. Expl. Expd., Crust. i. p. 607, pl. xl. fig. 8 (1852); Bate, 'Challenger' Macrura, p. 211, pl. xxx. (1881).

The males of this species differ from the females in the form of

the first abdominal appendage. In the female this has the last joint longer than the preceding, narrow and acuminate, and the preceding joint usually without, sometimes with, one spine at the proximal end of the inner margin. In the male the same appendage has the last joint broad and not longer than the preceding, which is armed on its inner margin with one, usually with two or three spines. Further, in the male the first abdominal appendage is shorter relatively to the rest than in the female.

Five males and six females from Rotuma.

Tribe CARIDEA.

Family ATYIDÆ.

Subfamily ATYINÆ.

Genus CARADINA H. M.-Edwards, 1837.

3. CARADINA WYCKI (Hickson), 1888.

Atya wycki, Hickson, Ann. Mag. N. H. (6) ii. p. 357, pls. xiii. & xiv. (1888).

Caradina wycki, Thallwitz, Abh. Mus. Dresden, 1890-91, p. 27 (1891); de Man, Max Weber's Zool. Ergebn. ii. p. 386, pl. xxiv. figs. 29-29 k.

The single specimen of this species in the present collection has nineteen teeth on the upper border of the rostrum and eleven on the lower. It was taken in the Tamavua River, Viti Levu, Fiji.

4. CARADINA VITIENSIS, n. sp. (Plate LXIII. figs. 3, 3a.)

Definition.—"A *Caradina* with the rostrum straight, bearing 24 teeth above (none on the carapace) and 9 below, and reaching to somewhat beyond the middle of the second joint of the peduncle of the first antenna; carapace with an antennal spine and blunt pterygostomial angle; first antenna with the last joint of the peduncle about half the length of the preceding joint, and flagella subequal; second antenna with the scale longer than the peduncle of the first; third maxilliped as long as the peduncle of the first antenna; first pair of legs reaching the end of the first joint of the peduncle of the first antenna, with the fingers about equal in length to the palm; second pair of legs equal to the peduncle of the first antenna, with fingers considerably longer than the palm; and last three pairs of legs reaching the end of the second antennal scale."

Colour when living a pale, almost transparent green.

Length of the present specimen, from end of telson to tip of rostrum, 22 mm.

The telson of the single specimen has had the end broken off.

This species appears to be allied to *C. weberi* de Man [Max Weber's Zool. Ergebn. ii. p. 371, pl. xxii. fig. 23 (1892)], but differs from it in the larger number of teeth on the rostrum, the

greater stoutness of the second pair of chelæ, and the greater length of the last two pairs of legs.

One specimen from Suva, Tamavua River, Viti Levu, Fiji.

Family PONTONIDÆ.

Genus PERICLIMENES Costa, 1844.

Periclimenes, Costa, Ann. Ac. Aspir. Nat. Nap. ii. (1844); Borradaile, Ann. Mag. N. H. (7) ii. p. 380 (1898).

Pelias, Roux, 1831; *Anchistia*, Dana, 1852; *Dennisia*, Norman, 1861.

The *Pelias migratorius* of Keller does not belong to this genus, but is synonymous with *Palæmonetes varians* (Leach).

5. PERICLIMENES SPINIGERUS (Ortmann), 1890.

Anchistia spinigera, Ortmann, Zool. Jahrb. v. Syst. 3, p. 511, pl. xxxvi. figs. 23, 23a (1890).

Periclimenes spinigerus, Borradaile, Ann. Mag. N. H. (7) ii. p. 383 (1898).

One specimen from Rotuma.

6. ? PERICLIMENES DANÆ (Stimpson), 1860. (Plate LXIII. figs. 4-4b.)

Anchistia danæ, Stimpson, Proc. Ac. N. Sci. Philad. 1860, p. 39.

Periclimenes danæ, Borradaile, Ann. Mag. N. H. (7) ii. p. 382 (1898).

The collection contains a single specimen, which I have some hesitation in referring to this species.

The rostrum is straight, somewhat shallow, armed with seven teeth above and two below, and just reaches the end of the antennular peduncle. The carapace is armed with supraorbital, antennal, and hepatic spines. The eyes are large and project considerably on either side of the body. The first antenna is longer than the scale of the second by three-quarters of the length of its thicker flagellum. The slender inner flagellum is unfortunately broken short on both sides; it has the appearance, however, of having been *longer* than the outer one. The flagella of the second antenna are broken off. The scale is longer than the peduncle of the first antenna.

The third maxilliped reaches the end of the first joint of the antennular peduncle.

The first pair of legs exceed the thicker flagellum of the first antenna by about the length of the fingers. These are about as long as the palm. The second legs exceed the antennular peduncle by the wrist and chelæ, and the first legs by almost the whole chela. The distal end of their wrist is prolonged dorsally into a short spine, and the fingers are shorter than the hand. The fourth and fifth legs are subequal, and reach the end of the wrist of the first leg. The fifth pair are slender and attain the

end of the merus of the first leg. The telson is shorter than the uropods, and bears two long spines at the hind end.

The points of difference from Stimpson's description are:—

(1) The presence of two spines below the rostrum, instead of three.

(2) The inner flagellum of the first antenna is probably longer than the outer.

The specimen is 11 mm. long and has a somewhat immature appearance. It was taken among the seaweed of the reef at Funafuti.

7. *PERICLIMENES ROTUMANUS* Borradaile, 1898. (Plate LXIII. figs. 5-5b.)

Periclimenes rotumanus, Borradaile, Ann. Mag. N. H. (7) ii. p. 383 (1898).

The rostrum of this species is barely as long as the peduncle of the first antenna, and almost straight, and bears six teeth above and two below, the first of the former being situated on the carapace and the second just above the orbit. The carapace has the hepatic and antennal spines present. The thicker flagellum of the first antenna is about as long as the peduncle, the inner being more than twice as long as the outer. The scale of the second antenna is longer than the peduncle of the first, and the flagellum is longer than the body.

The third maxilliped reaches the end of the peduncle of the first antenna.

The merus of the second leg reaches the end of the first joint of the antennular peduncle, and the whole limb the end of the inner flagellum. The wrist bears a small spine above, and the merus one below, at the distal end. The wrist, palm, and fingers are subequal. The first legs nearly reach the end of the palm of the second. Their wrist is longer than the hand, and slightly longer than the merus. The fingers are about as long as the palm. The third pair of legs is broken off. The fourth and fifth are subequal and longer than the scale of the second antenna.

The endopodite and exopodite of the uropod are equal and outreach the telson. The latter is armed at the end with six spines, of which the outermost are the smallest and the intermediate the largest.

The length of the single specimen is 11 mm. It was taken in Rotuma.

8. *PERICLIMENES VITIENSIS* Borradaile, 1878. (Plate LXIV. figs. 6-6b.)

Periclimenes vitiensis, Borradaile, Ann. Mag. N. H. (7) ii. p. 383 (1898).

In this species the rostrum reaches almost to the end of the thicker flagellum of the first antenna. It is bent upwards at the free end and bears above six teeth, of which the first is situated above the orbit, and below four. The carapace is armed with

supraorbital, antennal, and hepatic spines, and with one in the dorsal median line, some little distance behind the rostrum. The pterygostomial angle is subrectangular. The slender flagellum of the first antenna of the present specimen is broken short on the right side and, I think, also on the left. On the latter side it is as long as the thicker flagellum, which is very stout and about equals the peduncle in length. The scale of the second antenna extends to the end of the rostrum, and the flagellum is about as long as the body.

The third maxilliped reaches the end of the penultimate joint of the antennular peduncle.

The wrist in the first pair of legs ends slightly beyond the scale of the second antenna and bears a spine on the inner side at its distal end. The fingers are about equal to the palm. The legs of the second pair are almost equal, and exceed those of the first by nearly the whole length of the hand; they are armed at the distal end of the merus with a spine below, and at that of the wrist with one on the inside. The third and fourth pairs of legs are subequal, reach the last third of the wrist of the second pair, and are armed with several slender spines on the underside of the propodite. The fifth pair reach halfway up the propodite of the fourth, and have their own propodite armed with a strong spine at the distal end on the underside and with two more slender ones proximally of this. The carpus in each leg of the last three pairs projects dorsally at the outer end as a blunt spine.

The endopodite and exopodite of the uropod are subequal and somewhat longer than the telson, which bears six spines at the hind end. Of these spines the outermost are the shortest, and the intermediate the longest.

The length of the single specimen is 20 mm. from the tip of the rostrum to the end of the telson.

This species is closely allied to *P. grandis* (Stimpson), but is separated by the shortness of the fourth pair of legs, and of the second as far as the end of the merus, and by its smaller size; and is therefore perhaps better regarded as distinct. If *P. petithouarsi* Miers (non Audouin) be rightly regarded as synonymous with *P. grandis* Stimpson, we may add as further differences the presence of six, instead of five, teeth on the dorsal border of the rostrum (excluding that on the carapace behind the rostrum in each case), and of four, instead of three, teeth on the inferior border. The rostrum, too, of Miers's species is "nearly straight," while that of *P. vitiensis* has a marked upward trend at the free end.

One female, with eggs, from Viti Levu, Fiji.

Genus CORALLIOCARIS Stimpson, 1860.

9. CORALLIOCARIS BREVIROSTRIS Borradaile, 1898. (Plate LXIV. figs. 7-7*d*.)

Coralliocaris brevirostris, Borradaile, Ann. Mag. N. H. (7) ii. p. 386 (1898).

This species has the rostrum unarmed and reaching only to the

middle of the first joint of the antennular peduncle. The carapace is short and unarmed. The first joint of the peduncle of the first antenna is longer than the second and third together, the second and third joints subequal. The inner and outer flagella are subequal and reach well beyond the fringe of the antennal scales. The scale of the second antenna is longer than the peduncle of the first.

The third maxilliped reaches the end of the first joint of the antennular peduncle.

The first leg exceeds the antennal scale by the hand and the last half of the wrist. The second legs are equal. The merus almost reaches the end of the antennal scale, and is armed distally with a spine at the lower and outer angle. The wrist is short and broad, and the hand longer than the carapace and fairly stout. The fingers are barely half the length of the palm, and the immovable finger has on the inner side a large swelling, indented by a notch, into which fits the single small tooth on the movable finger. The last three pairs are subequal, the third pair reaching the wrist of the second.

The exopodite of the uropod is slightly longer than the endopodite, and both are considerably longer than the telson. The latter is armed at the end with six spines, of which the two outermost are the smallest and the intermediate pair the longest.

The length of the single specimen is 19 mm.

Coralliocaris brevirostris is allied to *C. macrophthalma* (H. M. Edw.), but may be distinguished from it by the following features:—

- (1) The rostrum reaches only the middle of the first joint of the antennular peduncle. In *C. macrophthalma* it reaches the beginning of the last joint.
- (2) The inner flagellum of the first antenna is longer than in *C. macrophthalma*.
- (3) The shape of the fingers of the second chela is different in the two species.

One female from Funafuti.

Genus CONCHODYTES Peters, 1851.

10. CONCHODYTES MELEAGRINÆ Peters, 1851.

Conchodytes meleagrinae, Peters, Ges. naturf. Freunde Berlin, 1851 (fide Heller); Ber. k. Ak. Wiss. Berlin, 1852, p. 594; Hilgendorf, Monatsber. k. Ak. Wiss. Berlin, 1878, p. 836; Borradaile, Ann. Mag. N. H. (7) ii. p. 390 (1898).

Pontonia meleagrinae, Bate, 'Challenger' Macrura, p. 707, pl. cxxiv. figs. 1, 2 (1888).

One male and one female from Rotuma.

Family PALÆMONIDÆ.

Genus PALÆMONELLA Dana, 1852.

11. PALÆMONELLA TRIDENTATA n. sp. (Plate LXIV. figs. 8–8c.)

Definition.—“A *Palæmonella* with the rostrum straight, slightly outreaching the antennular peduncle, and bearing 7 teeth above

(2 on the carapace) and 3 below; the carapace with hepatic and antennal spines; the first antenna having the first joint of its peduncle as long as the second and third joints together, and its flagella subequal and not so long as the second pair of legs; the second antenna with the peduncle shorter than the first joint of that of the second, the flagellum longer than the body, and the scale longer than the antennular peduncle; the third maxilliped reaching the end of the second joint of the antennular peduncle; the first pair of legs outreaching the rostrum by the wrist and hand; the legs of the second pair unequal, the right larger and outreaching the first pair by nearly the whole of the hand, bearing a spine below at the free end of the merus and one above at the free end of the wrist, with the fingers barely half the length of the palm; the legs of the last three pairs subequal, reaching beyond the end of the rostrum; and the endopodite and exopodite of the uropods equal, and longer than the telson, which ends in six spines, the outermost pair being the smallest and the intermediate the longest."

The length of the single specimen is 21 mm. from the end of the telson to the tip of the rostrum.

The animal when alive was colourless and almost transparent.

The species differs from *P. tenuipes* Dana in the following points:—

- (1) There are three teeth on the underside of the rostrum, instead of two.
- (2) The inner edges of the fingers of the second pair of chelæ are armed with teeth.
- (3) The distal end of the merus is rounded in profile, but provided with a large spine below at a short distance from the end. In *P. tenuipes* it is acute in profile and without the tooth.
- (4) The arrangement of teeth on the inner ramus of the mandible is different in the two species (fig. 8*d*).

One specimen from Funafuti.

Genus PALÆMON Fabricius, 1798.

12. PALÆMON LAR Fabricius, 1798.

Palæmon lar, Fabricius, Entom. Syst., Suppl. p. 402 (1798); Ortman, Zool. Jahrb. v. Syst. 5, p. 724 (1891); de Man, Max Weber's Zool. Ergebn. ii. p. 445 (1892).

Palæmon ornatus, Olivier, Encycl. viii. p. 660; H. M.-Edwards, H. N. Crust. ii. p. 396 (1837).

Bithynis lar, Bate, 'Challenger' Macrura, p. 789, pl. cxxix. fig. 1 (1888).

As de Man (*loc. cit.*) points out, the end of the telson is frequently worn or broken off in this species, so that the separation from it of forms with this structure truncated is unreliable.

Mr. Gardiner states that this species is very common in the upper waters of all the rivers of Fiji. In Taviuni it was formerly reserved as food for chiefs.

Eight males from Tamavua River, Viti Levu, Fiji.

13. PALÆMON sp.

One specimen from Tamavua River, Viti Levu, differing from *P. lar* in having three instead of one or two of the spines of the rostrum situate on the carapace. Second legs missing.

Family HIPPOLYTIDÆ.

Genus SARON Thallwitz, 1891.

14. SARON MARMORATUS (Olivier), 1811.

Palæmon marmoratus, Olivier, Encycl. viii. (fide H.M.-Edwards).

Alpheus marmoratus, Lamarck, Hist. Anim. sans Vert. v. p. 205.

Hippolyte marmoratus, H. M.-Edwards, H. N. Crust. ii. p. 379, pl. xxv. fig. 8 (1837).

Hippolyte marmorata, Randall, J. Ac. N. Sci. Philad. viii. 1, p. 142 (1839); de Man, Arch. Naturg. liii. 1, p. 533 (1887); Ortmann, Zool. Jahrb. v. Syst. 3, p. 497 (1890).

Hippolyte gibberosus, H. M.-Edwards, H. N. Crust. ii. p. 378 (1837); Atl. Cuv. R. An., Crust. pl. liii. fig. 4 (1849); Haswell, Cat. Austr. Crust. p. 185 (1882); Whitelegge, Funafuti Atoll, Crust. p. 146 (1897).

Hippolyte gibbosus, Dana, U.S. Expl. Exped., Crust. i. p. 565, pl. xxxvi. fig. 4 (1852); Streets, Bull. U. S. Nation. Mus. vii. p. 119 (1877).

Hippolyte gibberosa, de Man, Arch. Naturg. liii. 1, p. 533 (1888); Zool. Jahrb. ix. Syst. p. 761, fig. 68 (1897); Ortmann, Zool. Jahrb. v. Syst. 3, p. 497 (1890).

Hippolyte hemprichii, Heller, S.B. Ak. Wiss. Wien, 44, Abth. 1, p. 275, pl. iii. fig. 23 (1861); Verh. zool.-bot. Ges. Wien, xi. p. 29 (1861).

Saron gibberosus, Thallwitz, Zool. Anz. xiv. p. 99 (1891); Abh. Mus. Dresd. 1890-91, No. 3, p. 25; Ortmann, Semon's Forschungsreisen, v. 1, p. 16 (1894).

Randall (*loc. cit.*) first pointed out that the females of *S. marmoratus* differ from the males in the structure of the third maxillipeds, which in the male are considerably longer than the antennal scales and pointed at the tip, while in the female they never outreach the scales and are obliquely truncated at the end. Ortmann (Zool. Jahrb. *loc. cit.*) states that female *S. marmoratus* resemble *S. gibberosus* in every point save in the number of spines on the merus of the last three pairs of legs. The former species has, according to him, two spines on the legs of the third and fourth pairs and one on that of the fifth, while the latter has one spine on the legs of the third and fourth pairs and none on those of the fifth.

De Man (Zool. Jahrb. *loc. cit.*) goes further and shows that even these spines are extremely variable, and that specimens of *S. gibberosus* may be provided with as many of them as *S. marmoratus*. (The figures given on p. 1010 for the present collection will be seen to bear out this statement.) He thinks, however, that Ortmann's

females belonged to *S. gibberosus*, and that the true females of *S. marmoratus* will be found to possess the characteristic third maxillipeds of the male, at least in form if not in length. For this conclusion, however, there is no evidence whatever. The other authors make no reference to the sexual characters. In Mr. Gardiner's collection there are seventeen females and thirty males from Rotuma, all taken in the same localities and in the same position, namely, on the "reef-flat" and "rough-zone" of the outer reef. The males can be sharply divided into two groups, having the *marmoratus*- and *gibberosus*-characteristics respectively. The females, however, are all of the *gibberosus* type.

Taking into consideration the statements of Ortmann and de Man, these facts point, I think, to the conclusion that *Saron marmoratus* is a species with a dimorphic male, one form resembling the female, and the other differing from it in the length of the third maxilliped¹ and first pair of legs and in the form of the last joint of the third maxilliped. This appendage is well described and figured by de Man (*Zool. Jahrb. loc. cit.*).

Should the above surmise prove to be correct, the question will arise whether the dimorphism of the male be permanent or occur only at the breeding-season, as has been shown by Faxon [*Am. Journ. Sci.* xxvii. (1894)] to be the case for the males of *Cambarus*. On this point there is no direct evidence. The presence, in Mr. Gardiner's and other collections, of both forms of the male, taken at the same time, might seem rather to negative the latter suggestion; but in view of the fact that tropical marine forms tend to breed all the year round, the question must still remain open.

Sex.	Number with 2 spines on merus of last leg.	Number with 1 spine.	Total.
Females.....	6	9	15
<i>gibberosus</i> -males	11	9	20
<i>marmoratus</i> -males	2	7	9
			44
Female with 3 spines on left side, 2 on right		1	
Female " 2 " " 1 "		1	
<i>marmoratus</i> } " 1 " " 2 "		1	
male			3
			47

Some interesting remarks on dimorphism in male Crustacea are contained in the Report on the Isopoda of the 'Lightning'

¹ According to Ortmann this difference in the length of the third maxilliped is not so marked in individuals from East Africa (Semon's Forschungsreisen, *loc. cit.*). His note, however, on this point is somewhat obscure, and it is quite possible that his specimens were *gibberosus*-males without a spine on the fifth merus.

expedition, by Messrs. Norman and Stebbing [Tr. Z. S. xii. p. 104 (1890)].

The colour in this species varies from mottled grey to green, but the colour-variations have no relation to those in form or length of the appendages.

The table on p. 1010 shows the variations in the spines on the legs of the last pair in the specimens from Rotuma.

The legs of the third and fourth pairs had two spines on the merus in every case save one. This was a female with only one spine on the left fourth leg. The specimen was among those with one spine on the legs of the fifth pair.

From Funafuti are two *marmoratus*-males with two spines on the merus of the last pair of legs, and two females with one spine.

Family ALPHEIDÆ.

Genus ATHANAS Leach, 1814.

15. ATHANAS SULCATIPES, n. sp. (Plate LXV. figs. 9-9 i.)

Definition.—“An *Athanas* with the rostrum straight, simple, sword-like, and reaching the end of the second joint of the antennular peduncle; the carapace armed with supra- and infraorbital spines only; the first antenna with the inner flagellum about twice as long as the outer; the second antenna with the peduncle somewhat longer than the first two joints of that of the first antenna, the flagellum about as long as the body, the scale slightly longer than the antennular peduncle and bearing a long fringe; the third maxillipeds slightly outreaching the antennal scale; the first pair of legs unequal, the larger in the male overlapping the antennal scale by the last third of its merus, which is large and deeply hollowed underneath, the wrist in the same limb being short, unarmed, and also hollow underneath, and the hand about as long as the two preceding joints, with the fingers shorter than the palm, apposed, and curved inwards. In the female the longer leg resembles that of the male, but is shorter and less robust. The smaller leg in the male is of the same form as the larger, save that the fingers are curved towards one another and enclose a gap, and reaches about halfway up the hand of the larger leg. In the female, on the other hand, the smaller leg is of a quite simple form, entirely unlike the larger, and reaches to about the end of the merus of the latter. The legs of the second pair have the wrist five-jointed, with the first joint larger than the second, third, and fourth together, the latter three joints equal, and the fifth longer than either of them, and reach, in the male, to the end of the merus of the longer leg of the first pair. The third pair of legs is nearly as long as the second, and the fourth and fifth are subequal, a little shorter than the third. The uropods have the endopodite and exopodite subequal and are somewhat longer than the telson, which ends in a fringe of hairs, and is provided with two pairs of spines on the upper surface.”

The mouth-parts and other limbs are shown in figs. 9 *b-e*.

Length of largest male 9 mm., of largest female 8 mm.

This species is allied to *A. dimorphus* Ortmann, 1894, but is at once separated from it by the shape of the first pair of legs and the presence of the supraorbital spine.

Five females bearing eggs, and three males, from Funafuti.

Genus ALPHEUS Fabricius, 1778.

16. ALPHEUS STRENUUS Dana, 1852.

Alpheus strenuus, Dana, U.S. Expl. Exped., Crust. i. p. 543, pl. xxxiv. fig. 4 (1852); Ortmann, Zool. Jahrb. v. Syst. 3, p. 475 (1890); Coutière, Notes Leyd. Mus. xix. p. 199 (1897).

The specimens in the present collection are provided with a spine at the distal end of the merus of the great chela.

From Rotuma: three males and three females.

From Funafuti: four males and ten females.

17. ALPHEUS MACROCHIRUS Richters, 1880.

Alpheus macrochirus, Richters, Beit. Meeresf. Maur., Decapoden, p. 164, pl. xvii. figs. 31-33 (1880); Ortmann, Zool. Jahrb. v. Syst. 3, p. 485 (1890).

One specimen from Rotuma.

18. ALPHEUS PARVIROSTRIS Dana, 1852.

Alpheus parvirostris, Dana, U.S. Expl. Exped., Crust. i. p. 551, pl. xxxv. fig. 3 (1852); Ortmann, Zool. Jahrb. v. Syst. 3, p. 483 (1890).

One specimen from Funafuti.

19. ALPHEUS COLLUMIANUS Stimpson, 1860.

Alpheus collumianus, Stimpson, Proc. Ac. N. Sci. Philad. 1860, p. 99; Ortmann, Zool. Jahrb. v. Syst. 3, p. 483, pl. xxxvi. fig. 15 *k, m* (1890).

One specimen from Funafuti.

20. ALPHEUS LEVIS Randall, 1839.

Alpheus levis, Randall, Journ. Ac. N. Sci. Philad. viii. p. 141 (1839); Dana, U.S. Expl. Exped., Crust. i. p. 556, pl. xxxv. fig. 8 (1852); Ortmann, Zool. Jahrb. v. Syst. 3, p. 487 (1890); Whitelegge, Funafuti Atoll, Crust. p. 146 (1897).

From Funafuti five specimens, two of them females with eggs.

From Rotuma sixteen specimens, five of them females with eggs.

21. ALPHEUS FRONTALIS Say, 1832.

Alpheus frontalis, Say, Journ. Ac. N. Sci. Philad. i. p. 245 (1832); H. M.-Edwards, H. N. Crust. ii. p. 356 (1837); Atlas to Cuvier's R. An. pl. liii. fig. 2 (1849); Ortmann, Zool. Jahrb. v. Syst. 3, p. 488 (1890).

From Rotuma five specimens; from Funafuti one.

22. *ALPHEUS PROLIFICUS* Bate, 1888.

Alpheus prolificus, Bate, 'Challenger' Macrura, p. 556, pl. xcix. fig. 4 (1888); Ortmann, Zool. Jahrb. v. Syst. 3, p. 484 (1890).

One specimen from Funafuti.

23. *ALPHEUS PACHYCHIRUS* Stimpson, 1860.

Alpheus pachychirus, Stimpson, Proc. Ac. N. Sci. Philad. 1860, p. 99; Ortmann, Zool. Jahrb. v. Syst. 3, p. 489, pl. xxxvi. fig. 17 *a, k* (1890).

Three specimens from Rotuma.

24. *ALPHEUS GRACILIPES* Stimpson, 1860.

Alpheus gracilipes, Stimpson, Proc. Ac. N. Sci. Philad. 1860, p. 31.

One female from Rotuma.

25. *ALPHEUS FUNAFUTENSIS*, n. sp. (Plate LXV. figs. 10–10 *h*.)

Definition.—"An *Alpheus* with the rostrum arising from the anterior border of the carapace, continued backwards as a keel between the eyes, and not reaching the end of the first joint of the antennular peduncle; with the eye-covers unarmed; the scale at the base of the first antenna not so long as the first joint of the peduncle, the second joint of this peduncle somewhat longer than the first, nearly twice as long as the third; the second antenna with a rudimentary spine on the basal joint, and the scale longer than the peduncle of the first antenna, as long as that of the second; longer leg of the first pair notched above and below, with a longitudinal ridge on the outside and the fingers shorter than the palm, without a spine on the merus; smaller leg of the first pair simple in structure, with elongated fingers; legs of second pair longer than those of first, wrist with second joint slightly longer than first, which again is longer than fifth, and third and fourth joints short, subequal; merus of legs of third and fourth pairs with a spine; endopodite and exopodite of uropods subequal, somewhat longer than telson."

The mouth-parts and other limbs are shown in figs. 10 *b-e*.

When alive the specimens were of a green colour. Length of largest specimen 24 mm.

This species may be distinguished from *A. edwardsi* by the following characters:—

- (1) The scale of the basal joint of the first antenna is not so long as that joint.
- (2) The proportions of the joints in the wrist of the second pair of legs are different in the two species.
- (3) The merus is provided with a spine in the third and fourth pairs of legs.
- (4) The smaller leg of the first pair has the movable finger simple in both sexes.

Seven specimens from Funafuti; three of them females with eggs.

Genus METABETÆUS, nov.

26. METABETÆUS MINUTUS (Whitelegge), 1897.

Betæus minutus, Whitelegge, Funafuti Atoll, Crust. p. 142, pl. vii. fig. 4 a, b (1897).

M. Coutière's researches [Bull. Mus. Paris, ii. p. 380 (1896)] necessitate, I think, the establishment of a new genus for this species. The following are the characters which together differentiate this proposed genus from those already diagnosed:—

- (1) Eyes not covered in front by the carapace.
- (2) Carapace with short, flat, triangular rostrum and minute ocular teeth.
- (3) Cornea lateral, eyestalks very broad and armed each with a spine above.
- (4) Outer flagellum of the first antenna bifid.
- (5) Palp of mandible two-jointed.
- (6) Branchial formula the same as that given by Bate for *Alpheus*.
- (7) First pair of legs simple, equal, with movable fingers as in *Betæus*.

The genus is allied to *Jousseauinea*, but is separated from it by the shape of the legs of the first pair, and by the presence of an arthrobranch on the first maxilliped. From *Alpheopsis* it is sundered by the presence of the arthrobranch, the spines on the eyestalks, and, seemingly, by the minute size of the ocular spines on the carapace.

Numerous specimens from Funafuti.

Tribe SCYLLARIDEA.

Family SCYLLARIDÆ.

Genus PARIBACUS Dana, 1852.

27. PARIBACUS ANTARCTICUS (Rumph.).

Ibacus antarcticus (Rumph.), H. M.-Edwards, H. N. Crust. ii. p. 287 (1837).

Paribacus antarcticus, Dana, U.S. Expl. Exped., Crust. i. p. 517, pl. xxxvi. fig. 6 (1852).

Two males from Rotuma.

Family PALINURIDÆ.

Genus PANULIRUS Gray.

28. PANULIRUS PENICILLATUS (Olivier), 1811.

Astacus penicillatus, Olivier, Encycl. Méth. vi. p. 343 (1811).

Palinurus penicillatus, H. M.-Edw. H. N. Crust. ii. p. 299 (1837).

Panulirus penicillatus, Stimpson, Proc. Ac. N. Sci. Philad. 1860, p. 92; Bate, 'Challenger' Macrura, p. 52, pl. xii. fig. 2 (1888).

Senex penicillatus, Ortmann, Zool. Jahrb. vi. Syst. p. 28.

One female with eggs from Rotuma.



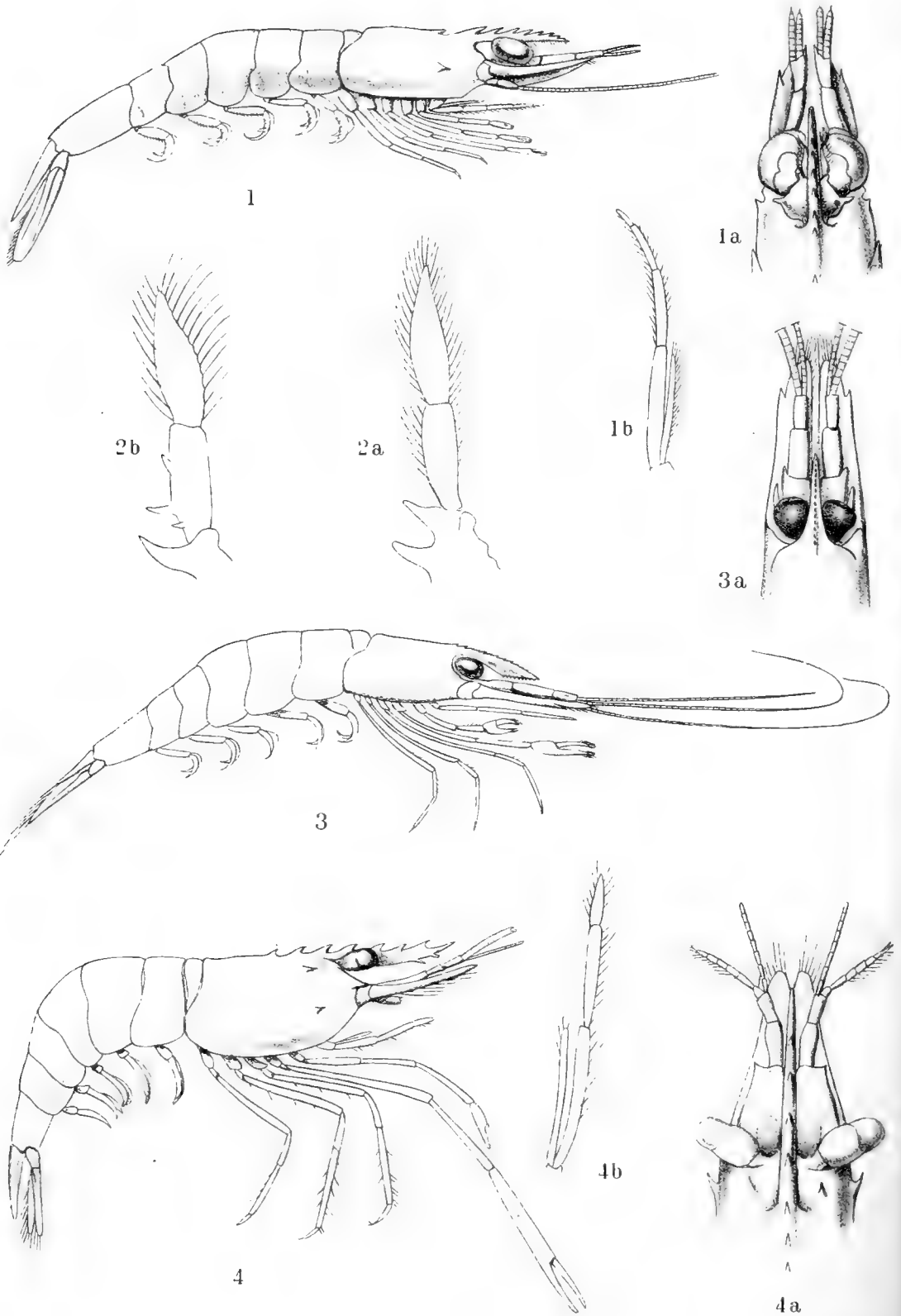

Edwin Wilson, del. ad. nat. lith. Cambridge

MACRURA FROM THE SOUTH PACIFIC.



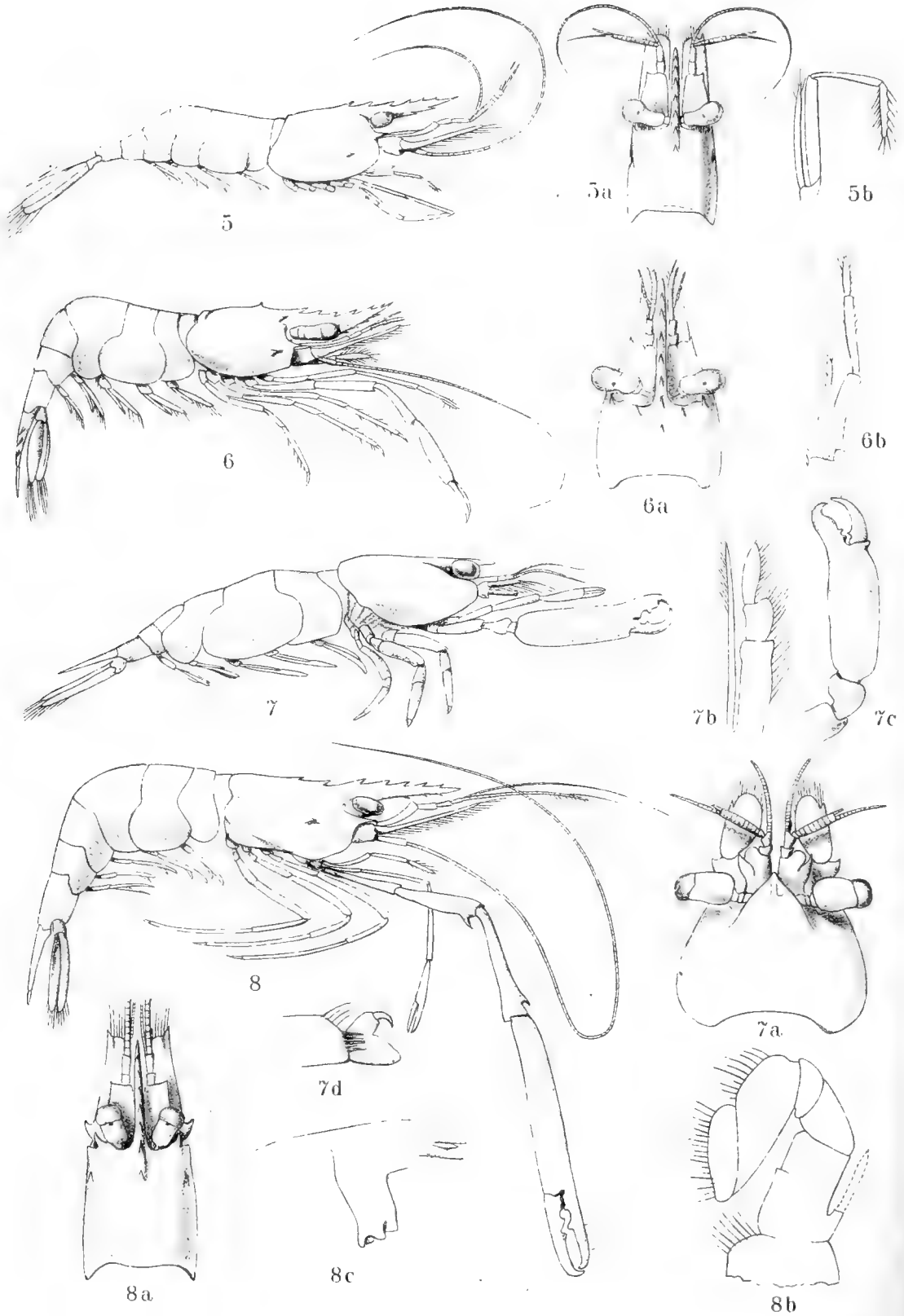

Edwin Wilson, del. ad. nat. lith. Cambridge.



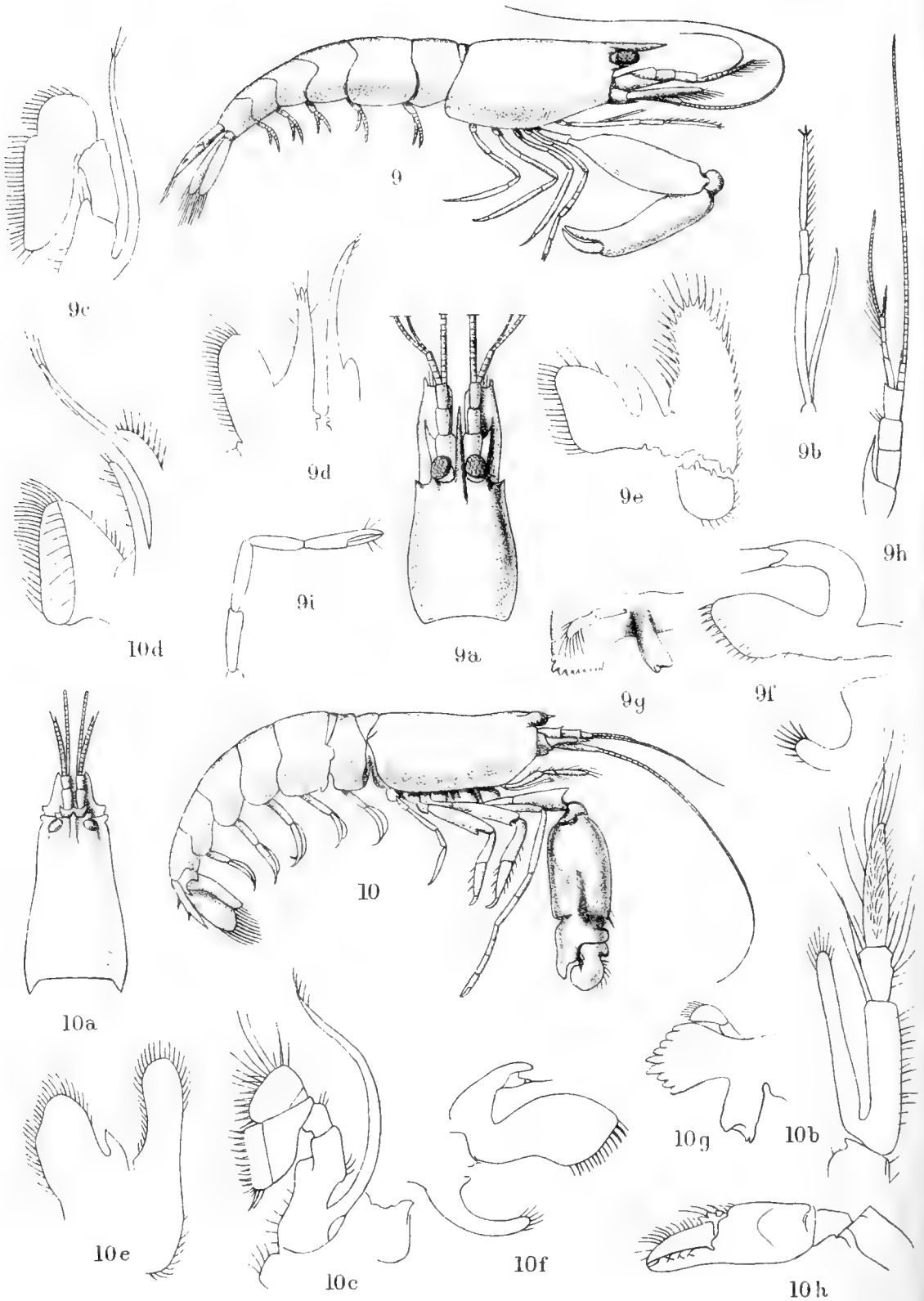

Edwin Wilson del. ad. nat. lith. Cambridge

Tribe THALASSINIDEA.

Family CALLIANASSIDÆ.

Genus CALLIANIDEA H. M.-Edwards, 1837.

29. CALLIANIDEA TYPA H. M.-Edwards, 1837.

Callianidea typa, H. M.-Edwards, H. N. Crust. ii. p. 329,
pl. xxv. bis, figs. 8-14 (1837).

From Rotuma six specimens ; from Funafuti six specimens.

EXPLANATION OF THE PLATES.

PLATE LXIII.

- Fig. 1. *Metapcnæus commensalis*, n. sp., p. 1001, side view. $\times 1\frac{1}{2}$.
 1 a. " " " head from above. $\times 2$.
 1 b. " " " 3rd maxilliped.
 2 a. *Stenopus hispidus* (Olivier), p. 1002, 1st abdom. append. of ♀.
 2 b. " " " 1st abdom. append. of ♂.
 3. *Caradina vitiensis*, n. sp., p. 1003, side view. $\times 4$.
 3 a. " " " head from above.
 4. *Periclimenes danæ* (Stimpson), p. 1004, side view. $\times 8$.
 4 a. " " " head from above. $\times 10$.
 4 b. " " " 3rd maxilliped.
 5. *Periclimenes rotumanus*, Borradaile, p. 1005, side view. $\times 5$.
 5 a. " " " head from above. $\times 5$.
 5 b. " " " 3rd maxilliped.

PLATE LXIV.

- Fig. 6. *Periclimenes vitiensis*, Borradaile, p. 1005, side view. $\times 3$.
 6 a. " " " head from above. $\times 3$.
 6 b. " " " 3rd maxilliped.
 7. *Coralliocaris brevisrostris*, Borradaile, p. 1006, side view. $\times 4$.
 7 a. " " " head from above. $\times 4$.
 7 b. " " " 3rd maxilliped.
 7 c. " " " chela of 2nd pair.
 7 d. " " " dactyle of 3rd leg.
 8. *Palæmonella tridentata*, n. sp., p. 1007, side view. $\times 4$.
 8 a. " " " head from above. $\times 4$.
 8 b. " " " 2nd maxilliped.
 8 c. " " " mandible.

PLATE LXV.

- Fig. 9. *Athanas sulcatipes*, n. sp., p. 1011, ♂, side view. $\times 8$.
 9 a. " " " head from above. $\times 8$.
 9 b. " " " 3rd maxilliped.
 9 c. " " " 2nd maxilliped.
 9 d. " " " 1st maxilliped.
 9 e. " " " 2nd maxilla.
 9 f. " " " 1st maxilla.
 9 g. " " " mandible.
 9 h. " " " 1st antenna.
 9 i. " " " smaller leg of 1st pair of ♀.
 10. *Alpheus funafutensis*, n. sp., p. 1013, side view. $\times 4$.
 10 a. " " " head from above. $\times 4$.
 10 b. " " " 3rd maxilliped.
 10 c. " " " 2nd maxilliped.
 10 d. " " " 1st maxilliped.
 10 e. " " " 2nd maxilla.
 10 f. " " " 1st maxilla.
 10 g. " " " mandible.
 10 h. " " " smaller leg of first pair.

6. Contributions to our Knowledge of the Plankton of the Faeroe Channel¹.—No. VII. A. General Data of the Stations. B. The Protozoa. C. The Medusæ. By G. HERBERT FOWLER, B.A., Ph.D., Assistant Professor of Zoology, University College, London.

[Received December 6, 1898.]

(Plate LXVI.)

A.—GENERAL DATA OF THE STATIONS.

In the table now exhibited (see p. 1019) will be found the chief details of the successive collecting stations of H.M.S. 'Research' in the Faeroe Channel, 1896 and 1897: Stations 11² to 18 being in the "Cold Area," between July 30 and Aug. 6, 1896; Station 19 in the "Warm Area," Aug. 7, 1896; Station 20 in the "Cold Area," July 7, 1897.

The physical conditions of the Channel have been fully dealt with in the Reports of the various exploring expeditions³ which have surveyed this classic district, of which it is not an exaggeration to say that the very beginnings of modern oceanography were made in its somewhat troubled waters.

DETERMINATION OF THE HORIZONS.

The horizons through which the Mesoplankton net remained open in 1896 were thus determined. In the first place, experimental hauls were made near the surface, to determine the number of fathoms through which the net must be towed at an approximately constant speed in order that the propeller (1) might open the net, (2) might shut it again. Of these experimental hauls, the contents of which were mostly not kept, the last one retained was 12*d*.

¹ Owing to the scanty leisure at my disposal, the series of papers under this title has been unavoidably disconnected.

The first three numbers dealt with some conspicuous and interesting species; the fourth, by Mr. I. C. Thompson, with the Copepoda; the fifth, by Mr. E. W. L. Holt, with the fish-larvæ; the sixth furnished a description of the special nets used for the Mesoplankton, and a short discussion of the general question of a midwater fauna. This and the future papers will discuss the organisms captured, group by group, and show their horizons by tables when necessary.

The references to previous papers of the series in the Society's Proceedings are:—No. I., 1896, p. 991; No. II., 1897, p. 523; No. III., 1897, p. 803; No. IV., 1898, p. 540; No. V., 1898, p. 550; No. VI., 1898, p. 567.

² Stations 1-10 were collecting-grounds in the neighbourhood of Kirkwall and do not concern the 'Research' cruises.

³ C. Wyville Thomson: 'Depths of the Sea.' London, 1873, 8vo (H.M.S. 'Lightning' and 'Porcupine').—T. H. Tizard and J. Murray: "Exploration of the Faeroe Channel in 1880." Proc. Roy. Soc. Edinb. xi. p. 638 (H.M. hired ship 'Knight Errant').—T. H. Tizard: "Soundings and Temperatures obtained in the Faeroe Channel during the Summer of 1882." Proc. Roy. Soc. xxxv. p. 202 (H.M.S. 'Triton').

The procedure was then as follows:—The net and machinery, weighted up to 100 lbs., were lowered overboard, and a number of fathoms run out, slightly greater than that of the sounding in the case of the lowest horizon; the angle made by the line when taut was approximately measured, and a calculation made from Traverse Tables in the ordinary way as to the depth which the net had reached. As I have pointed out already¹, this, the usual method, is most fallacious; for the towing-line does not form the hypotenuse of a right-angled triangle (as presupposed by this method), but an unknown catenary, which is practically uncalculable except

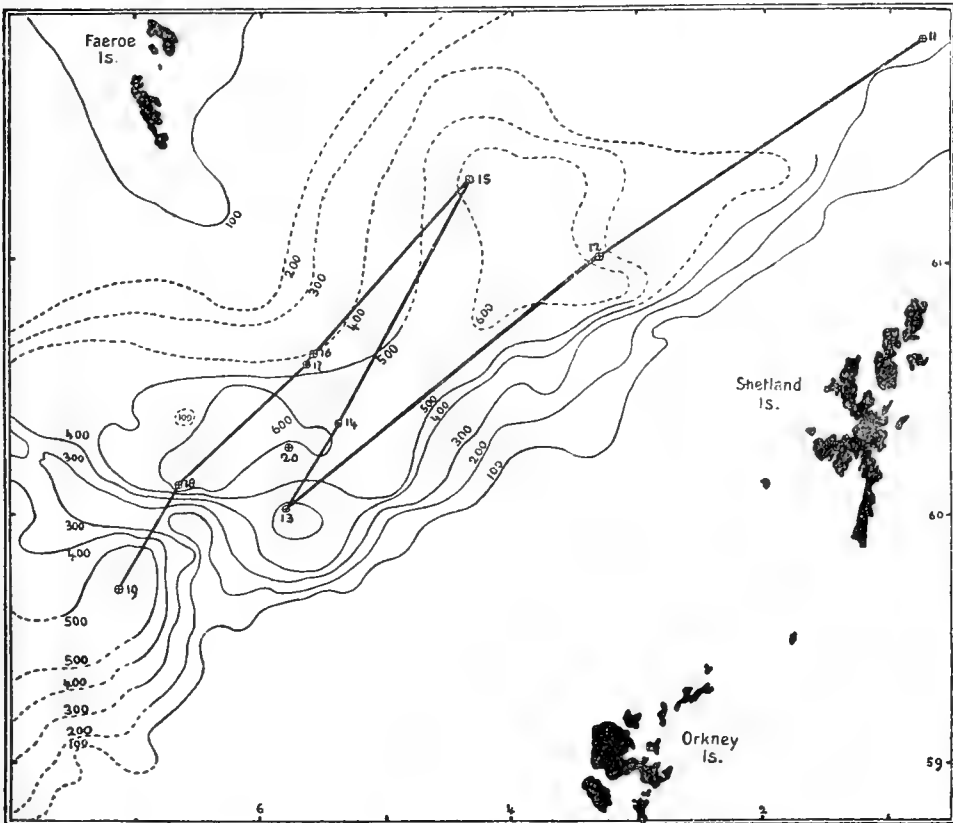

CHART OF THE FAEROE CHANNEL,

Showing the collecting-stations of H.M.S. 'Research' in 1896 and 1897. The contour-lines have been roughly plotted from the Admiralty Chart and from the soundings taken on these cruises: they are dotted where the soundings are far apart. (Station 20 (1897) is N. of Station 13.)

by tedious experiment in order to obtain the necessary data. The fallaciousness of this method was brought home to me by striking bottom at 398 fathoms (Station 16 *a i*) with 450 fathoms of warp out, though by quadrant and traverse tables the net should only have reached 300 fathoms. Fortunately all the details of the previous hauls had been kept; and as there was sufficient evidence, from

¹ Proc. Zool. Soc. 1898, p. 568.

the condition of the paint and the small quantity of bottom-deposit in the collecting-tin, that the net had not more than touched bottom without dragging on it, I was able to get, from this accident, data for the correction of the other deep-water hauls. While, therefore, the horizons of the Mesoplankton hauls may perhaps be understated (if the net had rested long on the bottom in haul 16 *a i*), the depth is certainly not exaggerated.

That the calculation of the depth reached in this manner was a very close approximation to the truth, can fortunately be shown in another way. During the 1896 cruise, Captain Moore and the other Officers were engaged in taking serial temperatures¹; and a minimum thermometer was sent down on the locking-gear of my net with every haul after 12 *e*. A comparison of the temperatures thus recorded on the net, and of the temperatures independently observed or interpolated on a curve by the Officers, is given below, where column I. shows the station number and haul letter; column II., the probable depth reached by the net (about 50 fathoms below the point at which it opened) as calculated from the data furnished by Station 16 *a i* when the net struck bottom; column III., the temperature recorded by the thermometer on the net, after correction; column IV., the temperatures for the depth given in column II., as independently observed or interpolated in the curves in Captain Moore's Report.

I.	II.	III.	IV.
13 <i>a</i>	180	47·0	47·0
13 <i>b</i>	356	32·6	33·0
13 <i>d</i>	445	32·0	31·25
13 <i>e</i>	445	32·0	31·25
13 <i>g</i>	516	30·75	31·0
15 <i>c</i>	578	31·0	30·75
16 <i>a i</i>	400	30·6	30·9 at 380 fath.
16 <i>a ii</i>	356	31·0	31·5
18 <i>b</i>	578	31·0	31·0 at 600 fath.
19 <i>a</i>	534	46·0	46·8 at 550 fath.

Considering the different times of day, and the slightly different positions owing to the ship's drift, at which the two sets of observations were made, their approximation is very close.

With the net of the 1897 pattern, which presented less resistant surface and less buoyancy than the other, no calculation of the depth was required: the line hanging vertically to the surface, the number of fathoms paid out indicated the depth sufficiently accurately. As to the rate of travel of the messengers, had time (*i. e.* weather) permitted, this would have been carefully worked into a curve: as it was, the impact could be felt at the less depths, and had to be guessed (good margin being allowed) for the greater depths. That the messengers travelled very rapidly was shown by the deep dints that they received on striking the locking-gear.

¹ W. U. Moore: Reports of Proceedings in connection with Investigations into the Physical Conditions of the Water of the Faeroe Channel.—Hydrographic Department, Admiralty, 1896, 4to.

TEMPERATURES.

The temperatures given in the table are compiled from the readings of the thermometer on my net, and from the observations and interpolations published by Captain Moore (*op. cit. supra*).

Station Number and Haul Letter.	Position of ship.	Sounding in fathoms.	Horizon explored, in fathoms.	Temperature (Fahrenheit.) of horizon explored.	Mesher per inch.
11 a ...	61° N., 0° long.	203	100-+0	48°-54°	25
11 b ...	" "	"	0	54°	180
11 c ...	" "	"	30-0	49°-54°	36
12 a ...	61° N., 3° W.	502	±350-±150	31°-43°	25
12 b ...	" "	"	10-0	53°	36
12 c ...	" "	"	0	53°	180
12 d ...	" "	"	130-+0	44°-53°	25
12 e ...	" "	"	450-320	30°-32°	25
12 f ...	" "	"	?10-0	? 53°	? 36
13 ab ...	60° N., 5° W.	575	300-0	33°-54°	25
13 c ...	" "	"	2-0	54°	36
13 d ...	" "	"	400-270	32°-38°	25
13 e ...	" "	"	400-?	32°-?	25
13 f ...	" "	"	0	54°	180
13 g ...	" "	558	465-335	31°-33°	25
13 h ...	" "	"	0	54°	180
13 i ...	" "	"	100-0	48°-54°	36
13 k ...	" "	624	2-0	53°	36
13 l ...	" "	"	0	53°	180
14 ...	" "	"	0	54°	180
15 a ...	61° N., 4° W.	610	2-0	53°	36
15 b ...	" "	"	0	53°	36
15 c ...	" "	"	530-0	31°-53°	25
15 d ...	" "	"	0	53°	13
16 a i ...	60° N., 5° W.	398	350-220	31°-37°	25
16 a ii ...	" "	"	300-170	33°-44°	25
16 b ...	" "	"	0	53°	36
16 c ...	" "	"	4-0	53°	36
17 ...	" "	"	0	53°	13
18 a ...	60° N., 6° W.	645	3-0	53°	36
18 b ...	" "	"	530-400	31°-32°	25
19 a ...	59° N., 7° W.	595	480-350	46°-47°	25
19 b ...	" "	"	480-0	46°-54°	25
19 c ...	" "	"	4-0	54°	36
19 d ...	" "	"	10-0	54°	36
20 a ...	60° N., 5° W.	560	200-100	39°-46°	40
20 b ...	" "	"	300-200	33°-39°	40
20 c ...	" "	"	400-300	31°-33°	40
20 d ...	" "	"	500-400	30°-31°	40
20 e ...	" "	"	0	52°	36
20 f ...	" "	"	0	52°	180
20 g ...	" "	"	40-0	52°	36

CLASSIFICATION OF THE HAULS.

In the first table (p. 1019) the hauls are arranged in succession of number and letter, in order to facilitate reference; but in the subsequent tables of species they will be classified as Epiplankton (0 to ± 100 fathoms); Mesoplankton (± 100 fathoms from surface to ± 100 fathoms from bottom); and "doubtful hauls," in which the net failed to shut at the expected horizon, or in which the contents of two hauls were accidentally mixed. On comparing these tables of species with that given in Mr. Thompson's paper on the Copepoda¹, it will be found that a few changes have been made. No. 12 *a* has been moved from among the "doubtful" to the Mesoplankton hauls, because it certainly closed somewhere near 100 fathoms, although perhaps not so low as 150; 12 *f* proves, by the character and condition of its contents, to have been made very near the surface, and has been put with the Epiplankton hauls; 13 *e*, about which I entered a note of suspicion in the station-book when it arrived inboard, proves to contain several essentially epiplanktonic organisms which do not occur in any other Mesoplankton haul, and has therefore been relegated to the "doubtful" category: in all probability one of the chains hung on the trigger for some time after the net should have completely closed; the details of this haul will be given later.

B.—THE PROTOZOA.

It was not to be expected that this group would yield much information with regard to the special object of the cruise, the Mesoplankton fauna. For the efficient study of the Protozoa, the nets must be extremely fine, so fine that they must be towed very slowly; and if they are towed slowly, a large part of the other constituents of the catch will escape. Special hauls with special nets, or a special arrangement inside the large mesoplankton net (which I hope to try shortly), are requisite for successful captures. On the other hand, some of my hauls show that certain Phæodaria live at great depths, although they do not show that any species are confined to the Mesoplankton.

As regards the surface Protozoa, no special attempt was made to collect them, for they were not required for comparison with the Mesoplankton fauna; and, further, my finest net, the only one suitable for Protozoa, was almost entirely devoted in 1896 to the capture by Dr. Stericker, R.N., of vegetable plankton for the Scottish Fishery Board. A few new and interesting forms of considerable size were, however, obtained.

Two things are apparent on a glance at the table of Protozoa—the one, the epiplanktonic character of the three Periphyllaria; the other, the way in which several species are aggregated in the same haul, while other hauls show few or no Radiolaria. They seem to

¹ Proc. Zool. Soc. 1898, pp. 542-3.

appear and disappear together in accordance with varying external conditions.

Only those species appear in the table, the horizons of which seem to be in any way significant; the horizons of the rest will be simply recorded in the text.

RADIOLARIA PERIPYLARIA.

THALASSICOLLA sp.

A number of specimens of this genus, taken chiefly at the surface, could not be assigned with certainty to any species already described. As with *Collozoum*, observations on living material seem to be necessary in order to determine the specific position. The following characters are enumerated here in order to assist future recorders in identifying the form from this locality:—The striated calymma is very thick and colourless, the alveolar layer internal to this is also very thick and colourless, with large alveoli; the extracapsular pigment is generally yellowish, occasionally dark in colour; the central capsule is dark and considerably thicker than in *T. nucleata*; in specimens of which sections were made, the membrane of the central capsule appeared to be divided up into numerous small polygonal areas, with a single large pore in the centre of nearly every area; the nucleus is circular, with a thickish nuclear membrane and irregular nucleolus; intracapsular inclusions?

The proportion of central capsule to nucleus, often utilized as a specific character, does not appear to be trustworthy for this purpose. The table below gives this proportion in a number of specimens, apparently all referable to the same species: column I. shows the total diameter in millimetres, arranged in order of size; column II. shows the diameter of the central capsule expressed as a percentage of the total diameter.

I.	II.	I.	II.
3.38	29	1.27	38
3.29	19	1.26	33
2.10	40	1.23	28
1.96	21	1.11	33
1.96	21	1.09	32
1.90	30	1.09	32
1.75	22	1.07	21
1.70	22	.93	37
1.68	41	.92	30
1.61	21	.77	26
1.47	23	.63	36
1.44	22		

The proportions of striated calymma, alveolar layer, and central capsule showed similar variations.

It seems highly probable from the table that this *Thalassicolla* is

	Station Number and Haul Letter.	Horizon in fathoms.	<i>Thalassioella</i> sp.	<i>Colozoum</i> sp.	<i>Siphonosphera tizardi</i> , sp. n.	<i>Aulacantha levis-sima</i> Hkl.	<i>Autographis</i> sp.	<i>Autographis moorensis</i> , sp. n.	<i>Auloceros trigeminus</i> Hkl.
EPIPLANKTON.	11 a.	100-+0	::	+	::	::	::	::	::
	11 b.	0	+	+	+	::	::	::	::
	11 c.	30-0	+	+	::	::	::	::	::
	12 b.	10-0	::	::	::	::	::	::	::
	12 c.	0	::	::	::	::	::	::	::
	12 d.	150-+0	::	::	::	::	::	::	::
	12 f.	? 10-0	::	::	::	::	::	::	::
	13 c.	2-0	::	+	::	::	::	::	::
	13 d.	0	::	::	::	::	::	::	::
	13 h.	0	::	::	+	::	::	::	::
	13 i.	100-0	+	+	+	+	::	::	::
	13 k.	2-0	+	+	+	::	::	::	::
	13 l.	0	::	::	::	::	::	::	::
	14.	0	::	+	::	::	::	::	::
	15 a.	2-0	::	::	::	::	::	::	::
	15 b.	0	::	::	::	::	::	::	::
	15 d.	0	::	::	::	::	::	::	::
	16 b.	0	+	+	::	::	::	::	::
	16 c.	4-0	+	+	::	::	::	::	::
	17.	0	+	::	::	::	::	::	::
18 a.	3-0	+	+	+	::	::	::	::	
19 c.	4-0	::	::	+	::	::	::	::	
19 d.	10-0	::	::	::	::	::	::	::	
20 e.	0	::	::	::	::	::	::	::	
20 f.	0	::	::	::	::	::	::	::	
20 g.	40-0	::	::	::	::	::	::	::	
MESOPLANKTON.	12 a.	+350-+150	::	::	::	::	::	::	::
	12 e.	450-320	::	::	::	::	::	::	::
	13 d.	400-270	::	::	::	::	::	::	::
	13 g.	465-335	+	::	::	+	::	::	+
	16 a i.	350-220	::	::	::	::	::	::	::
	16 a ii.	300-170	::	::	::	::	::	::	::
	18 b.	530-400	::	::	::	::	::	::	::
	19 a.	480-350	::	::	::	+	+	+	+
	20 a.	200-100	::	::	::	::	::	::	::
	20 b.	300-200	::	::	::	::	::	::	::
20 c.	400-300	::	::	::	::	::	::	::	
20 d.	500-400	+	::	::	::	::	::	::	
Doubtful.	13 a b.	300-0	::	::	::	+	::	::	+
	13 e.	400-?	+	+	+	::	+	::	+
	15 c.	530-0	::	::	::	+	+	::	+
	19 b.	480-0	::	+	+	+	::	::	+

an epiplanktonic form; it was plentiful at the surface, but in 13*g* and 20*d* only single specimens were captured, which were probably dead or dying and sinking to the bottom.

For the horizons of capture, see the table on p. 1022.

COLLOZOOM spp.

Of this genus there were apparently two separate species represented in my collections, neither of which could be attributed to *Collozoum inerme* from the warm Atlantic, or to *C. ellipsoides*, described by Haeckel from the Faeroe Channel. In the one type the largest spherical zooids of the colony measured about $\cdot 05$ to $\cdot 07$ mm. in diameter, in the second type about $\cdot 09$ to $\cdot 16$ mm.; both had about $\cdot 2$ to $\cdot 28$ mm. of calymma and alveoli outside the zooids. In the first type there was a considerable thickness of alveolar calymma in the centre of the colony, as in the ordinary *C. inerme*; but in the spherical or lenticular colony of the second type the zooids were so closely aggregated in the centre of the colony as all but to touch one another, and were surrounded by a thick alveolar layer and a thick radiately striate calymma, exactly as a *Thalassicolla*.

Although I have no doubt that at least one undescribed species of *Collozoum* occurs in these waters, I do not feel justified in naming and describing it without a detailed examination of living material.

Both types were confined to the Epiplankton, except for a few specimens in haul 13*e*, which appears to have remained open through higher horizons than was intended or at first believed, and is now included with the doubtful hauls. As the *Collozoum* occurred in 30% of the Epiplankton hauls, and in no undoubted Mesoplankton haul, I think we are justified in regarding it as essentially epiplanktonic.

For the horizons of capture, see the table on p. 1022.

LAMPOXANTHIUM MURRAYANUM, sp. n.¹

Definition of the Species.—Spicules of the skeleton numerous, geminate-radiate, with a short axial rod, from each of which spring three or four acute shanks, devoid of branches or forks (sometimes three shanks at one end, four at the other). Both rod and shanks smooth and straight; shanks two to three times the length of the rod. Calymma full of large alveoli. Diameter of calymma 3·5 mm.; diameter of central capsule 1 mm.

This large and beautiful species is undoubtedly referable to Haeckel's genus *Lampoxanthium*; but I am unable to place it with certainty in any of his subgenera, and it agrees with none of his species. In addition to the geminate-radiate spicules there are

¹ I have great pleasure in dedicating this species to Sir John Murray, K.C.B., F.R.S., who is specially associated with the Faeroe Channel by his part in the exploration of the district in the 'Knight Errant' (1880) and 'Triton' (1882).

also a few which may be radiate, or may be only broken off from the end of a geminate-radiate spicule.

The horizon of capture was doubtful; one specimen was taken at 13 *e*, one at 13 *ab*.

SIPHONOSPHERA (HOLOSIPHONIA) TIZARDI, sp. n.¹ (Plate LXVI. fig. 1.)

Definition of the Species.—Colony spherical (? always), up to about 2 mm. diameter. Zooids with a single spherical lattice-shell about .15 mm. in diameter, which is beset all over by short broad tubes. The tubes are very thin-walled and fragile, their walls slightly convergent, .010 to .018 mm. in diameter, and about .005 mm. high; there are five to seven tubes on the half meridian. Endosarc with very numerous nuclei; oil-globules?; zooxanthellæ very numerous, both inside and outside the shell, and also scattered through the calymma between the zooids.

In some hauls large numbers of the zooids had apparently broken away from the calymma, and appeared as solitary organisms referable to the family Liosphærida. As a warning to describers of Liosphærida, I may say that I had actually identified them as *Ethmosphæra leptosiphonia*, described by Haeckel from the Faeroe Channel, before I found them united in a colony.

So far as the evidence goes, the species is purely epiplanktonic; as it is a very conspicuous form, and it occurs with fair regularity at the surface (23 % of epiplankton hauls), and never with certainty in mesoplankton hauls, I think we are justified in accepting the evidence as fairly conclusive.

For the horizons of capture, see the table on p. 1022.

RADIOLARIA ACANTHARIA.

Acanthometron catervatum Haeckel (= *A. brevispina* Hkl.) was present in most hauls with the fine-meshed net in 1896, often in sufficient quantity to give a red tinge to the contents of the tow-net. In 1897 (Station 20) it was practically absent from the surface, like most things. A similar abundance and scarcity were recorded by the 'Knight Errant' in 1880 in this district².

RADIOLARIA PHÆODARIA.

This interesting group of Radiolaria was well represented in the 'Research' collections, but not so well as in the 'Triton' collections made by Sir John Murray in 1882.

The data afforded by my captures show the extreme danger of drawing conclusions as to the vertical distribution of a species from a few observations at a single "station." I have already pointed out³ that adequate data for this work can only be obtained

¹ I have pleasure in associating with this species the name of Captain T. H. Tizard, R.N., who explored the Faeroe Channel in command of the 'Knight Errant' (1880) and of H.M.S. 'Triton' (1882), to whom I am indebted for much valuable help.

² T. N. Tizard and J. Murray, Proc. Roy. Soc. Edinburgh, xi. p. 654.

³ Proc. Zool. Soc. 1898, pp. 578-580.

by numerous observations at all depths on successive days in a small area, and even these cannot be safely applied to a species unless it occurs constantly and in fair number in a large percentage of the hauls. The table of Phæodarian captures given on pp. 1022-3 would seem at first sight to point to about 100 fathoms as the upper limit of all the species except *Ceoloplegma murrayanum*; but the weakness of such an inference would lie in the fact that none of them were captured with anything like regularity in the Mesoplankton. That the argument would be false is shown by the fact that two of them were taken by Sir John Murray at the surface from H.M.S. 'Triton' in the same waters.

All the conclusions that can be drawn for the Faeroe Channel, from so few observations as those in the table, are:—

(1) That *Ceoloplegma murrayanum* is both epiplanktonic and mesoplanktonic, extending to at least 350 fathoms (19*a*) and a temperature of 33° Fahr. (13*g*). The large number of specimens taken at 13*g* and 19*a*, and the small number taken at or near the surface, showed that the deep specimens were not merely dead and sinking to the bottom.

(2) That *Aulacantha levissima* and *Aulosphæra flexuosa* may occur at considerable depths in the Mesoplankton; since the 'Triton' results showed them to exist at the surface also, they are, like *Ceoloplegma murrayanum*, to be regarded as epiplanktonic and mesoplanktonic. Though not present in such numbers as the first species, they were plentiful enough to make it extremely improbable that the specimens were dead and sinking.

(3) That *Aulographis moorensis* and *Auloceros trigeminus*, var., occur in the Mesoplankton, but it does not appear whether they are confined to it or not.

AULACANTHA LEVISSIMA Haeckel. (Plate LXVI. fig. 3.)

The youngest specimens referable to this genus in the 'Research' collections agreed entirely with Haeckel's description of *A. levissima*, except for the presence of a few extremely minute teeth on the larger spines. Larger specimens, however, with a central capsule about .4 mm. in diameter, and spines at least .9 mm. in length and calymma about 2 mm. in total diameter, exhibited a distinct denticulation (Plate LXVI. fig. 3). As *A. levissima* has been described only from the Faeroe Channel, it is probable that my specimens belong to the same species as those of Haeckel. I have therefore retained the name for "the smoothest" species described up to the present.

For the horizons of capture, see the table on p. 1022.

AULOGRAPHIS (AULOGRAPHONIUM) MOORENSIS¹, sp. n. (Plate LXVI. figs. 2, 4.)

Definition of the Species.—Radial tubes rounded proximately,

¹ With this new species I am glad to associate the name of Captain W. Osborne Moore, R.N., of H.M.S. 'Research,' to whose help I owe no small part of such success as my midwater experiments attained.

equally broad for most of their length, but then tapering slightly towards the distal end, at which the tube expands suddenly into a broad circular cushion. The margin of this cushion bears two verticils of radially divergent, slightly curved, terminal branches, about 10 to 16 in number; these are about twice as long as the inflated end of the tube is broad. Each branch is armed with two lateral rows of numerous recurved denticles, and bears a terminal spathilla of 5 to 8 recurved teeth (Plate LXVI. fig. 4).

One specimen: 480–350 fathoms, 46°–47° Fabr. (Station 19 a).

AULOCEROS (AULOCERÆA) TRIGEMINUS Haeckel, Var. nov.

A few shattered specimens, of what is probably only a variety of the species above named, exhibited a verticil formed by the twice-repeated dichotomous branching of the radial tubes, each verticil thus consisting of eight tynes.

The type species is known only from the 'Challenger' Station 353, between St. Vincent and the Azores, at a probable depth of 2965 fathoms (open tow-nets).

For the horizons of capture, see the table on p. 1022.

*AULOCORYNE ZETESIOS*¹, gen. et sp. n. (Plate LXVI. figs. 5, 6).

Aulocoryne (Family Aulacanthida):—Radial tubes without lateral branches, terminating in a club-shaped expansion which carries numerous fine radiating spines.

Aulocoryne zetesios:—The spines of the terminal club are thin, tubular, at first straight or slightly curved, then regularly zigzag, lastly straight; they are finely denticulate, and terminate in a spathilla of about 8–10 recurved teeth (Plate LXVI. fig. 6).

A single specimen only of this species was captured. Although so broken that not a single head was left on the radial tubes, many heads had been fairly well preserved with the calymma, and there could be no doubt as to its structure. The fine spines of the terminal club are of the same character as the tangential spines of *Cannorhaphis spathillata* and the radial spines of *Ceolodrymus anchoratus*: the same types of growth recur again and again in the various families of Phæodaria, first as scattered spicules, then as tubes radiating from the central capsule, then bound together in a coherent skeleton.

Unfortunately, the exact record of the horizon was lost; it was captured in either 13 e or 13 g.

CÆLODENDRUM (CÆLODENDRIDIUM) RAMOSISSIMUM Haeckel.

This species was fairly plentiful at Station 13 i. It has been described as cosmopolitan, from various stations and depths, but not, I think, from so far north as the Faeroe Channel.

CÆLOPLEGMA MURRAYANUM-TRITONIS Haeckel.

These species of Haeckel are the extremes of a series of very

¹ αὐλός, κορύνη, tubular club; ζήτησις, in honour of H.M.S. 'Research.'

varying forms, all terms of which were represented in the 'Research' collections. The range in depth is now extended to 480-350 fathoms; the lowest temperature to 31°-33° F. It has not been recorded except from the Faeroe Channel.

For the horizons of capture, see the table on pp. 1022-3.

FORAMINIFERA.

GLOBIGERINA spp.

1. A very small species, probably a dwarfed *Gl. bulloides*, was fairly plentiful whenever the finest net was used at the surface. The specimens were spinous when captured¹.

2. On the occasion when the Mesoplankton net touched bottom, a very small quantity of bottom deposit was found in it, containing minute spineless Globigerinæ, which seemed to be referable to the species *G. bulloides* and *G. pachyderma*. It is very noticeable in balsam mounts of this sample that most of the supposed *G. pachyderma* are quite filled with what looks like brownish protoplasm, as are most of the bottom-living Foraminifera, but that most of the thin-shelled *G. bulloides* are clear and empty.—The brownish material, while yellowing slightly with nitric acid, does not give the brilliant tint of the usual xanthoproteic reaction. It would seem to be of a clayey nature, and is possibly, as Sir John Murray suggests, a stage in the formation of glauconite. It is extremely soft and friable, and when stained is almost indistinguishable from the similarly stained protoplasm of surface specimens.

The dependence of the formation of glauconite upon the presence of protoplasm has been pointed out in detail by Sir John Murray and the Abbé Renaud (Chall. Rep., Deep-Sea Deposits, pp. 385-390). If this material be of a glauconitic nature, its method of occurrence would seem to indicate that *G. pachyderma* on reaching the bottom contains more protoplasm than *G. bulloides*, and in that case probably lives nearer to the bottom. It is very desirable that voluminous samples of the bottom deposit should be taken in the Faeroe Channel in order to test this suggestion, and for the following reason.

The whole discussion as to whether *Globigerina* was a purely planktonic form, or could both float and creep at the bottom indifferently, would probably have been settled by the acceptance of the first alternative years ago, had it not been for an observation by Dr. Carpenter during the third cruise of the 'Porcupine'² which was recorded in his general discussion of the *Globigerina* question in 1875. This was to the effect that samples of water taken from immediately above the *Globigerina* ooze at 500-750 fathoms, in the Faeroe Channel, yielded on filtration "multitudes of young *Globigerinæ*," plentiful and small enough to make the water appear turbid.

The "cold area" of the Faeroe Channel is apparently the

¹ Cf. Brady: Proc. Roy. Soc. Edinburgh, xi. p. 717.

² W. B. Carpenter: Proc. Roy. Soc. xxiii. p. 235.

southernmost limit¹ for the occurrence of *G. pachyderma* in bottom deposits; it is abundant in Arctic deposits, but has never been recorded alive from the surface. *G. bulloides*, on the other hand, is only known to occur at the surface, although dead shells are plentiful in the deposits of the Faeroe Channel.

I venture to suggest that Dr. Carpenter's observation as to the presence of very small living *Globigerinae* just above the bottom may be harmonized with the generally accepted view that most, if not all, *Globigerinae* are essentially planktonic organisms, by the supposition that *G. pachyderma* is a mesoplanktonic form, at any rate in the Faeroe Channel. It is quite possible that it may occur at the surface farther north, but it would escape capture by any but the finest nets (diameter of the shell .3 mm., according to Brady; my largest specimens were about .15 to .2 mm.).

SILICOFLAGELLATA.

DICTYOCHA sp.

A fair number of spicules referable to this genus of Ehrenberg occurred in one or two surface-hauls, notably 13 *h.* They agreed on the whole with the spicules of *D. stapedia* and *rhombus* (Haeckel), but no sign of the protoplasmic body was traceable. Prof. Cleve² records *D. fibula* and *D. speculum* (Ehrenberg) for the same cruise.

DINOFLAGELLATA.

In reporting on the vegetable Plankton of the cruise of the 'Research' in 1896, Prof. Cleve³ records the following species of Dinoflagellata:—

Ceratium tripos Duj.

Ceratium furca Duj.

Ceratium tripos Ehrenb.; var. *baltica* Schütt; var. *macroceros* Ehrenb. = var. *scotica* Schütt; var. *longipes* Bail. = var. *tergestina* Schütt; var. *horrida* Cleve.

Peridinium divergens Ehrenb.

Pyrophacus horologium Stein.

With the exception of the last, with which I did not meet, all these occur in all hauls with the finest net, many of them in great abundance.

CILIATA—OLIGOTRICHA.

DICTYOCYSTA ELEGANS Ehrenberg.

A beautiful species of this genus was fairly plentiful in some hauls, notably 13 *h.* According to Moebius⁴ all the various forms of *Dictyocysta* are referable to Ehrenberg's species *elegans*, an

¹ H. B. Brady: Chall. Rep. Zool., ix. Foraminifera, p. 600 (cf. pp xii-xiv).

² 'Fifteenth Annual Report of Fishery Board for Scotland,' part iii. p. 302.

³ P. T. Cleve: Fifteenth Annual Report of Fishery Board for Scotland, 1896, part iii. p. 297.

⁴ O. Moebius: Fünfter Jahresbericht d. Commission z. wiss. Untersuch. d. deutschen Meere, 1887.

opinion which, I think, is not likely to be accepted by the next monographer of the group. My own specimens agreed exactly with Moebius's figure 28, pl. viii., and showed no signs of variation in the direction of other species. As regards the structure of the shell, I can confirm von Daday¹ as against previous observers in the belief that the neck (Aufsatz) consists of a meshwork, but that the body of the shell (Wohnfach), although appearing at first sight to be also a meshwork, is really a closed chamber. My specimens seem to show that the inner membrane of the "Wohnfach" is continuous everywhere except at the mouth, but that the outer membrane ceases at the so-called pores.

C.—THE MEDUSÆ.

My friend Mr. E. T. Browne has been kind enough to look over the few Medusæ of my collections. Of all groups this seems to suffer most in capture at sea. Near shore, or from an open boat, in fairly still water, the tow-net can be handled delicately; but on board ship in open water the characteristic sense-organs and delicate tentacles are broken by pressure against the tow-net, whether in the rolling of the ship or in the hauling of a mesoplankton net by steam-power from considerable depths.

In 1897 I tried to lessen the damage to surface forms, both by diminishing the net-mouth in proportion to the surface-area of the net, and by attaching the net-warp to a single-strap 'accumulator' of india-rubber; these certainly diminished, but did not avoid, damage. Only in a few cases was Mr. Browne able to assign a specific name; his list is as follows:—

- | | |
|------------------------------------|--|
| 1. <i>Lizzia blondina</i> Forbes. | 5. <i>Solmaris</i> (possibly) two spp. |
| 2. <i>Phialidium</i> sp. | 6. <i>Solmundella</i> sp. |
| 3. <i>Sarsia</i> sp. | 7. <i>Aglantha rosea</i> Forbes. |
| 4. <i>Sarsia gemmipara</i> Forbes. | 8. <i>Aglantha digitalis</i> Haeckel. |
| | 9. <i>Trachymema</i> sp. |

Of these the first five are probably purely epiplanktonic. *Lizzia blondina* was often present in such numbers as to tinge the contents of the tow-net.

Phialidium sp. (14) and *Sarsia* spp. (several hauls) presented no special features.

Solmaris sp. is almost certainly confined to the Epiplankton. A single specimen occurred in 20 c (400–300 fathoms); but as it occurred in 53% of Epiplankton hauls, often in great profusion, and only a single specimen in one Mesoplankton haul, the presumption is that the latter specimen was dead and sinking to the bottom².

As to *Solmundella*, my captures do not afford any evidence of its vertical distribution.

¹ E. von Daday: Mittheil. zool. Station in Neapel, vii. p. 486.

² Compare Proc. Zool. Soc. 1898, p. 579.

What appeared to be broken specimens of *Aglantha rosea* of Forbes occurred in small numbers in three surface hauls.

The eighth species,

AGLANTHA DIGITALIS (O. F. Müller, Haeckel pars),

represents such of Haeckel's *A. digitalis* as remains after the restoration of Forbes's *A. rosea*, and the removal of *A. digitalis* var. *occidentalis* Maas¹. In his great monograph Haeckel² put Forbes's *A. rosea* with eight marginal vesicles, and the old *A. digitalis* of O. F. Müller and Fabricius with four marginal vesicles, under the single species *A. digitalis*. Since then both species have been confused, until again separated by Browne³. It is consequently at present impossible to detail accurately the distribution of these two species, but it seems to be certain that *A. digitalis* occurs off Greenland and Northern Norway, and that *A. rosea* occurs as a neritic form round the British coasts (Valentia, Shetland, Heligoland). The one is certainly an Arctic form, the other a southern, even though they may overlap to a greater extent than we at present know.

This being so, it is not without significance that Mr. Browne, when going over my specimens without knowing the horizons, separated the *Aglanthæ* into two groups, *A. rosea* and *A. digitalis*, of which, on comparison with the station list, all the *A. rosea* were found to come from surface hauls, all the *A. digitalis* from deep hauls⁴. As *A. digitalis* was captured in 66% of Mesoplankton hauls, and never at the surface, the presumption is that it has, like other Arctic surface forms, sunk to deeper strata on reaching lower latitudes (warmer surface water).

Unfortunately the results of the 'National' do not throw any further light on the distribution of these two species, horizontally and vertically, for Maas (*op. cit. supra*) accepted Haeckel's fusion.

TRACHYNEMA sp.

A few specimens of a large medusa were apparently referable to this genus. Hemispherical in shape (15 mm. diam., 12 mm. high), its eight radii showed the heavy transverse musculature of *Trachymedusæ*. The eight tentacles were stumpy and thick, one at the end of each radial canal. The sense-organs had disappeared. The manubrium was about 5 mm. long, devoid of a "Magenstiel," and provided with four very small oral lappets. What seemed to be rudiments of generative organs were placed on the upper third of the radial canals.

¹ O. Maas: *Ergebnisse d. Plankton-Expedition. Die ceraspedote Medusen*, p. 24.

² E. Haeckel: *System der Medusen*, i. p. 272.

³ E. T. Browne: *Proc. Zool. Soc.* 1897, p. 833.

⁴ One small specimen of *Aglantha*, too much damaged for reference to either species, was taken at 16*b*. In the table it has been placed as a query under *A. rosea*.

It is the only *Trachynema* which approaches *T. funerarium* Hkl. in size; but its proportions, and the position of the generative organs, are against its being a young form of this species. In most recognizable points it lies between *T. octonarium* Hkl. and *T. eurygaster* Hkl.; but it agrees exactly with neither. The eight radial canals and manubrium were of a strong brick-red.

It occurred in deep or doubtful hauls only.

EXPLANATION OF PLATE LXVI.

- Fig. 1. *Siphonosphera tizardi*, sp. n., p. 1025. A single individual is represented by half the shell and by half a section of the central capsule: outside the latter are zooxanthellæ. Cam. luc.
- Fig. 2. *Aulographis moorensis*, sp. n., p. 1026. Termination of a radial tube. Cam. luc.
- Fig. 3. *Aulacantha lavissima* Haeckel, p. 1026. Termination of a radial tube in optical section, showing the denticulations. Cam. luc.
- Fig. 4. *Aulographis moorensis*, sp. n., p. 1026. A single terminal branch of a radial tube, showing the denticulations and spathilla. Cam. luc.
- Fig. 5. *Aulocoryne zetesios*, gen. et sp. n., p. 1027. Termination of a radial tube, showing the club covered with zigzag spines. This beautiful drawing is due to the skill of Miss Mabel Green.
- Fig. 6. *Aulocoryne zetesios*, gen. et sp. n., p. 1027. A single zigzag spine. Cam. luc.

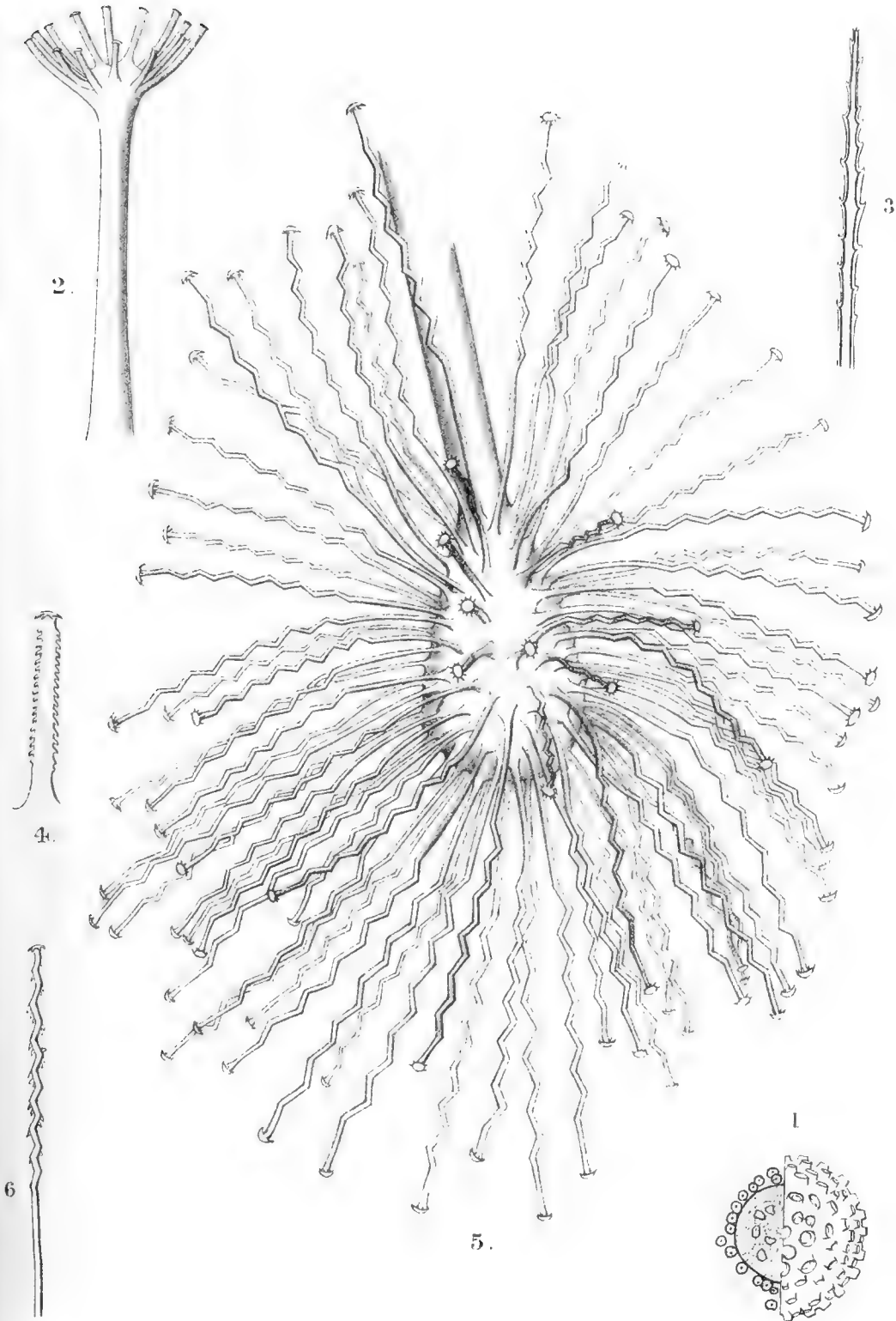

J. Smit lith.

Mintern Bros imp

PLANKTON OF THE FAEROE CHANNEL.



APPENDIX.

LIST OF ADDITIONS TO THE SOCIETY'S MENAGERIE

DURING THE YEAR

1898.

- Jan. 3. 3 Common Squirrels (*Sciurus vulgaris*). Purchased.
4. 1 Rhesus Monkey (*Macacus rhesus*), ♀. Presented by Miss Vine.
1 Indian Python (*Python molurus*). Presented by F. J. Allpress, Esq.
5. 1 Egyptian Jerboa (*Dipus cegyptius*). Presented by H. W. Wibrow, Esq.
7. 1 Razorbill (*Alca torda*). Purchased.
8. 12 Common Teal (*Querquedula crecca*). Purchased.
2 Common Wigeon (*Mareca penelope*), ♂ ♀. Purchased.
2 Blue-faced Honey-eaters (*Entomyza cyanotis*). Purchased.
11. 1 Greater Sulphur-crested Cockatoo (*Cacatua galerita*). Presented by Lady Pilkington.
12. 1 Japanese Ape (*Macacus speciosus*), ♂. Deposited.
1 Macaque Monkey (*Macacus cynomolgus*), ♀. Presented by Mr. R. S. Gleave.
13. 2 Herring-Gulls (*Larus argentatus*). Presented by the Rev. F. Hopkins.
14. 2 Aard Wolves (young) (*Proteles cristatus*). Presented by Capt. Baker.
1 Black-backed Piping-Crow (*Gymnorhina tibicen*). Presented by T. G. F. Winser, Esq.
15. 2 Ganga Cockatoos (*Callocephalon galeatum*), ♂ ♀. Purchased.
1 Red-tailed Buzzard (*Buteo borealis*). Deposited.
18. 1 Mozambique Monkey (*Cercopithecus pygerythrus*), ♀. Presented by Miss J. Rogers.
19. 1 Chinese Goose (*Anser cygnoides*). Presented by the Rev. E. Hensley.
20. 1 Smooth-headed Capuchin (*Cebus monachus*), ♂. Presented by W. S. Jay, Esq.
21. 1 Beccari's Cassowary (*Casuarus beccarii*?). Deposited.
24. 2 Uvæan Parrakeets (*Nymphicus uvæensis*), ♂ ♀. Purchased.
2 Black-headed Caiques (*Caica melanocephala*). Purchased.
1 Moor Macaque (*Macacus maurus*), ♀. Purchased.

- Jan. 25. 1 Red Fox (*Canis fulvus*). Presented by F. C. Ingram, Esq.
 28. 4 Virginian Opossums (*Didelphys virginiana*), 2 ♂, 2 ♀. Presented by J. D. Sprunt, Esq.
 2 Secretary Vultures (*Serpentarius reptilivorus*). Presented by J. E. Matcham, Esq., C.M.Z.S.
 3 Curlews (*Numenius arquata*). Purchased.
 3 Oyster-catchers (*Hæmatopus ostralegus*). Purchased.
 29. 1 Laughing Kingfisher (*Dacelo gigantea*). Presented by J. D. Waley, Esq.
 1 Lace Monitor (*Varanus varius*). Presented by J. D. Waley, Esq.
 1 Blue-tongued Lizard (*Tiliqua scincoides*). Presented by J. D. Waley, Esq.
 2 Stump-tailed Skinks (*Trachydosaurus rugosus*). Presented by J. D. Waley, Esq.
 1 Leopard (*Felis pardus*, jr.). Presented by J. D. Waley, Esq.
 1 Derbyan Wallaby (*Macropus derbyanus*), ♀. Presented by J. D. Waley, Esq.
 31. 1 Dingo Dog (*Canis dingo*). Presented by D. R. McDowall, Esq.
- Feb. 2. 1 Duiker Bok (*Cephalophus grimmii*), ♀. Presented by L. H. Nott, Esq.
 2 Black Larks (*Melanocorypha yeltoniensis*). Purchased.
 1 Salvadori's Cassowary (*Casuarus salvadorii*). Deposited.
 1 Long-legged Buzzard (*Buteo ferax*). Captured in the Red Sea. Presented by Mr. J. Kilpatrick.
 1 Kestrel (*Tinnunculus alaudarius*). Presented by Mr. J. Kilpatrick.
 3. 2 Axis Deer (*Cervus axis*), 2 ♀. Received in Exchange.
 1 Pink-headed Duck (*Rhodonessa caryophyllacea*), ♂. Received in Exchange.
 1 Javan Cormorant (*Phalacrocorax javanicus*). Received in Exchange.
 1 Indian Crow (*Corvus splendens*). Received in Exchange.
 4 Indian Spotted Doves (*Turtur suratensis*). Received in Exchange.
 2 Brown-headed Gulls (*Larus brunneicephalus*). Received in Exchange.
 1 Golden-naped Amazon (*Chrysotis auripalliata*). Presented by Gambier Bolton, Esq., F.Z.S.
 4. 2 Red Ground-Doves (*Geotrygon montana*). Presented by Lady Blake.
 1 Salvin's Amazon (*Chrysotis salvini*). Deposited.
 1 Blue-and-Yellow Macaw (*Ara ararauna*). Deposited.
 1 Red-and-Yellow Macaw (*Ara chloroptera*). Deposited.
 7. 1 Horned Lizard (*Phrynosoma cornutum*). Presented by Charles Iseard, Esq.
 8. 1 Green Monkey (*Cercopithecus callitrichus*). Presented by Robert O'Callaghan, Esq., F.Z.S.
 9. 3 Shaw's Gerbilles (*Gerbillus shawi*). Bred in the Menagerie.
 15. 1 Great Kangaroo (*Macropus giganteus*), ♂. Deposited.
 2 Australian Sheldrakes (*Tadorna tadornoides*), ♂ ♀. Purchased.
 17. 2 Chinese Quail (*Coturnix chinensis*), ♂ ♀. Purchased.
 6 Pintails (*Dafila acuta*), 3 ♂, 3 ♀. Purchased.
 18. 1 Australian Cassowary (*Casuarus australis*), ♀. Deposited.

- Feb. 23. 3 Black-backed Jackals (*Canis mesomelas*). Presented by J. E. Matcham, Esq., C.M.Z.S.
 1 Downy Owl (*Pulsatrix torquata*). Deposited.
 12 White's Tree-Frogs (*Hyla cœrulea*). Deposited.
 1 Bearded Lizard (*Amphibolurus barbatus*). Purchased.
 24. 1 Black-backed Jackal (*Canis mesomelas*). Presented by Capt. Travers.
 25. 2 Black-faced Spider-Monkeys (*Ateles ater*). Deposited.
 1 Temminck's Tragopan (*Cerionis temmincki*), ♀. Purchased.
 28. 3 Hybrid Gold Pheasants (bred between *Thaumalea picta* and *T. amherstiae*). Presented by Percy Tarbutt, Esq., F.Z.S.
- Mar. 2. 1 Indian River-Snake (*Tropidonotus piscator*). Purchased.
 3. 3 Urial Wild Sheep (*Ovis vignei*), 1 ♂, 2 ♀. From Beloochistan. Presented by B. T. Finch, Esq., F.Z.S.
 4. 1 Masked Paradoxure (*Paradoxurus larvatus*). Presented by Julius Neumann, Esq.
 1 Large Indian Civet (*Viverra zibetha*). Presented by Julius Neumann, Esq.
 5. 1 Common Seal (*Phoca vitulina*). Purchased.
 6. 1 Leopard (*Felis pardus*). Born in the Menagerie.
 7. 2 Cardinal Grosbeaks (*Cardinalis virginianus*). Purchased.
 8 Undulated Grass-Parrakeets (*Melopsittacus undulatus*), 4 ♂, 4 ♀. Purchased.
 1 Brown Gannet (*Sula leucogastra*). Purchased.
 8. 1 Black Lark (*Melanocorypha yeltoniensis*), ♂. Purchased.
 9. 2 Indian Chevrotains (*Tragulus meminna*), 2 ♂. Purchased.
 2 Prairie Marmots (*Cynomys ludovicianus*). Presented by J. Maurice Glyn, Esq.
 10. 1 Black Woodpecker (*Picus martius*). Purchased.
 1 Great Eagle-Owl (*Bubo maximus*). Presented by Capt. Betram Goff, late 71st Highland Light Infantry.
 4 Chinese Quails (*Coturnix chinensis*), 2 ♂, 2 ♀. Purchased.
 11. 1 Solitary Thrush (*Monticola cyanus*), ♂. Purchased.
 12. 1 Mantell's Apteryx (*Apteryx mantelli*). Purchased.
 1 Owen's Apteryx (*Apteryx oweni*). Purchased.
 1 Spotted Ichneumon (*Herpestes auropunctatus*). Presented by the Rev. Sidney Vatcher.
 14. 2 Hybrid Dusky Ducks (between *Anas boscas* ♂ and *Anas obscurus* ♀), ♂ ♀. Presented by W. H. St. Quintin, Esq., F.Z.S.
 15. 1 Snow-Bunting (*Plectrophenax nivalis*), ♂. Purchased.
 1 Manchurian Crane (*Grus japonensis*). Purchased.
 16. 1 Macaque Monkey (*Macacus cynomolgus*), ♀. Presented by M. Lyons, Esq.
 1 Common Fox (*Canis vulpes*), ♂. Presented by Miss Heard.
 1 Malayan Paradoxure (*Paradoxurus hermaphroditus*). Deposited.
 1 Mexican Deer (*Cariacus mexicanus*), ♂. Presented by H.E. Col. Wilson, C.M.G.
 1 Reddish Brocket (*Cariacus rufinus*), ♂. Presented by H.E. Col. Wilson, C.M.G.
 1 Globose Curassow (*Crax globicera*), ♀. Presented by H.E. Col. Wilson, C.M.G.
 17. 1 Senegal Parrot (*Pecocephalus senegalus*). Presented by Miss L. Firmin.
 18. 2 Lapwings (*Vanellus cristatus*). Purchased.

- Mar. 18. 2 Zebus (*Bos indicus*), ♂ ♀. Presented by Commander George Stevenson.
 7 Baer's Ducks (*Fuligula baeri*). Received in Exchange.
19. 1 Hairy Armadillo (*Dasyurus villosus*). Deposited.
 2 Argus Pheasants (*Argus giganteus*), ♂ ♀. Purchased.
 4 Gold Pheasants (*Thaumalea picta*), 2 ♂, 2 ♀. Purchased.
 2 Horned Tragopans (*Cerionis satyra*), ♂ ♀. Purchased.
 2 Lineated Pheasants (*Euplocamus lineatus*). Purchased.
 2 South-African Ostriches (*Struthio australis*), ♂ ♀. Received in Exchange.
 1 Grand Eclectus (*Eclectus roratus*). Deposited.
 2 Many-coloured Parrakeet (*Psephotus multicolor*), ♂ ♀. Purchased.
 4 Spotted-sided Finches (*Amadina lathamii*). Purchased.
21. 4 Radiated Tortoises (*Testudo radiata*). Deposited.
22. 1 Weka Rail (*Ocydromus australis*). Deposited.
24. 1 Herring-Gull (*Larus argentatus*). Presented by Mrs. Hovell.
25. 2 Hybrid Parrakeets (bred between *Platycercus eximius* ♂ and *Platycercus pallidiceps* ♀). Deposited.
27. 3 Bactrian Camels (*Camelus bactrianus*), 3 ♀. Deposited.
 1 Burchell's Zebra (*Equus burchelli*), ♀. Deposited.
 2 Yaks (*Poëphagus grunniens*), ♀ et juv. Deposited.
 1 Beisa Antelope (*Oryx beisa*), ♂. Deposited.
 1 South Albemarle Tortoise (*Testudo vicina*). Deposited. See P. Z. S. 1898, p. 245.
28. 1 Caucasian Wild Goat (*Cupra caucasica*, jr.), ♂. Received in Exchange.
29. 1 Molucca Deer (*Cervus moluccensis*), ♂. Presented by H.G. The Duke of Bedford, F.Z.S.
 4 Oyster-catchers (*Hæmatopus ostralegus*). Purchased.
30. 1 Great-billed Touracou (*Turacus macrorhynchus*). Presented by R. J. Nicholas, Esq.
31. 2 Cambayan Turtle-Doves (*Turtur senegalensis*). Presented by Sir Edward Burne-Jones.
 1 Razor-billed Curassow (*Mitra tuberosa*). Presented by R. Norton, Esq.
- April 1. 1 Macaque Monkey (*Macacus cynomolgus*), ♀. Presented by Capt. Francis W. Bate.
 1 Burchell's Zebra (*Equus burchelli*), ♀. Born in the Menagerie.
 2. 2 Arctic Foxes (*Canis lagopus*). Purchased.
 4. 1 Macaque Monkey (*Macacus cynomolgus*), ♀. Presented by Mrs. Grace Currie.
 1 White-tailed Sea-Eagle (*Haliaëtus albicilla*, jr.). From the Liantung Peninsula, China. Presented by J. W. Carrall, Esq.
 10 Californian Quails (*Callipepla californica*), 9 ♂, 1 ♀. Presented by Capt. Thomas Yardley Powles.
 5. 1 Rosy-billed Duck (*Metopiana peposaca*), ♂. Purchased.
 6. 1 Chimpanzee (*Anthropopithecus troglodytes*), ♂. Purchased.
 1 Egyptian Jerboa (*Dipus egyptius*). Deposited.
 1 Common Viper (*Vipera berus*). Presented by R. Tucker, Esq.
 7. 4 Egyptian Ichneumons (*Herpestes ichneumon*). Purchased.
 6 Common Gulls (*Larus canus*). Purchased.
 1 Common Kestrel (*Tinnunculus alaudarius*). Purchased.

- Apr. 7. 1 Reticulated Python (*Python reticulatus*). Purchased.
8. 1 Leopard (*Felis pardus*), ♂. Presented by Arthur Hudson, Esq.
9. 1 Puff-Adder (*Bitis arietans*). Presented by J. E. Matcham, Esq., C.M.Z.S.
- 2 Rough-keeled Snakes (*Dasypeltis scabra*). Presented by J. E. Matcham, Esq., C.M.Z.S.
- 4 Rhomb-marked Snakes (*Trimerorhinus rhombeatus*). Presented by J. E. Matcham, Esq., C.M.Z.S.
- 9 Crossed Snakes (*Psanmophis crucifer*). Presented by J. E. Matcham, Esq., C.M.Z.S.
11. 1 Gayal (*Bibos frontalis*), ♀. Born in the Menagerie.
- 1 Common Lapwing (*Vanellus cristatus*). Purchased.
- 2 Knots (*Tringa canutus*). Purchased.
- 1 Long-necked Chelodine (*Chelodina longicollis*). Presented by R. Kirkwood, Esq.
14. 1 Macaque Monkey (*Macacus cynomolgus*), ♂. Presented by H. Times, Esq.
- 2 Toco Toucans (*Ramphastos toco*). Purchased.
- 1 Moufflon (*Ovis musimon*), ♂. Born in the Menagerie.
- 1 Hog-Deer (*Cervus porcinus*), ♀. Born in the Menagerie.
15. 1 Robin (*Erithacus rubecula*, var.). Presented by Henry Kirkman, Esq.
- 1 Gold Pheasant (*Thaumalea picta*), ♂. Presented by Mrs. Abbot Robinson.
- 1 Red-vented Cockatoo (*Cucutua hæmaturonygia*). Purchased.
16. 1 Isabelline Bear (*Ursus isabellinus*). Presented by Major Whatman.
- 1 Silver-backed Fox (*Canis chama*). Presented by W. Champion, Esq.
- 1 Suricate (*Suricata tetradactyla*). Presented by W. Champion, Esq.
- 1 Grey-breasted Parrakeet (*Myopsittacus monachus*). Presented by Mrs. Evelyn Heathcote.
18. 4 Silver Pheasants (*Euplocamus nycthemerus*), 4♂. Presented by H. J. Veitch, Esq., F.Z.S.
19. 1 Common Barn-Owl (*Strix flammea*). Presented by Capt. George Innes.
- 1 Black-winged Peafowl (*Pavo nigripennis*), ♂. Presented by Richard H. J. Gurney, Esq., F.Z.S.
- 1 Collared Fruit-Bat (*Cynonycteris collaris*). Born in the Menagerie.
20. 1 Yellow-cheeked Lemur (*Lemur xanthomystax*). Born in the Menagerie.
- 1 Crested Porcupine (*Hystrix cristata*). Born in the Menagerie.
- 2 Squirrel-like Phalangers (*Belideus sciureus*), 2♂. Born in the Menagerie.
- 1 Red Kangaroo (*Macropus rufus*), ♂. Born in the Menagerie.
21. 2 Black Rats (*Mus rattus*). Presented by J. E. Ardron, Esq.
- 4 Undulated Grass-Parrakeets (*Melopsittacus undulatus*). Presented by A. Aitchison, Esq.
- 1 White-backed Piping-Crow (*Gymnorhina leuconota*). Bred in the Menagerie.
- 1 Black-bellied Sand-Grouse (*Pterocles arenarius*), ♂. Presented by E. G. B. Meade-Waldo, Esq., F.Z.S.

- Apr. 21. 1 Pin-tailed Sand-Grouse (*Pterocles alchata*), ♀. Presented by E. G. B. Meade-Waldo, Esq., F.Z.S.
 1 Rosy Bullfinch (*Erythropsiza githaginea*). Presented by E. G. B. Meade-Waldo, Esq., F.Z.S.
22. 2 Common Blue-birds (*Sialia wilsoni*).
 2 Yellow-bellied Liothrix (*Liothrix luteus*).
 1 Amaduvade Finch (*Estrela amandava*).
 1 Red-bellied Waxbill (*Estrela rubriventris*).
 1 Crimson-eared Waxbill (*Estrela phoenicotis*).
 4 Amaduvade Finches (*Estrela amandava*).
 1 Green Waxbill (*Estrela formosa*).
 1 Common Waxbill (*Estrela cinerea*).
 2 Red-bellied Waxbills (*Estrela rubriventris*).
 3 Orange-cheeked Waxbills (*Estrela mel-poda*).
 1 Chestnut-eared Finch (*Amadina castanotis*).
 1 Bar-breasted Finch (*Munia nisoria*).
 2 Black-headed Finches (*Munia malacca*).
 2 Chestnut-bellied Finches (*Munia rubronigra*).
 3 Indian Silver-bills (*Munia malabarica*).
 1 Maja Finch (*Munia maja*).
 2 Banded Grass-Finches (*Poëphila cincta*).
 1 Paradise Whydah-bird (*Vidua paradisea*).
 1 Golden-backed Weaver-bird (*Pyromelana aurea*).
23. 1 Common Otter (*Lutra vulgaris*). Presented by A. P. Ashburnham, Esq.
 3 Hairy-footed Jerboas (*Dipus hirtipes*). Presented by Miss Baird.
 1 Green-cheeked Amazon (*Chrysotis viridigena*, var.). Deposited.
25. 1 Macaque Monkey (*Macacus cynomolgus*), ♀. Presented by Mrs. Burrell.
 2 Beautiful Grassfinches (*Poëphila mirabilis*), ♂ ♀. Purchased.
 2 Indian Silver-bills (*Munia malabarica*). Presented by the Lady Charlotte Amherst.
- 12 Midwife Toads (*Alytes obstetricans*). Purchased.
 1 Barbary Wild Sheep (*Ovis tragelaphus*). Born in the Menagerie.
26. 1 Pinima Curassow (*Crax pinima*), ♂. Presented by Dr. Emil A. Goeldi, C.M.Z.S. See P. Z. S. 1898, p. 348.
 1 Hybrid Fowl and Guinea-fowl (between *Numida meleagris* ♂ and *Gallus domesticus* ♀), ♀. Presented by Dr. Emil A. Goeldi, C.M.Z.S. See P. Z. S. 1898, p. 348.
 1 Mona Monkey (*Cercopithecus mona*), ♀. Presented by Mrs. Christina G. R. Potter.
 2 Turtle-Doves (*Turtur communis*). Presented by G. J. Plows, Esq.
27. 1 Californian Sea-Lion (*Otaria californiana*), ♂. Received in Exchange.
 2 Common Toads (*Bufo vulgaris*). Presented by D. P. Turner, Esq.

Presented by
Miss Edith M.
Kemp-Welch.

Presented by
Miss Petroco-
chino.

- Apr. 27. 1 Ring-tailed Coati (*Nasua rufa*). Presented by Basil T. Freeland, Esq.
 1 Mantled Buzzard (*Leucopternis palliata*). Presented by Basil T. Freeland, Esq.
29. 1 Grey Ichneumon (*Herpestes griseus*). Born in the Menagerie.
 3 Barbary Wild Sheep (*Ovis tragelaphus*). Born in the Menagerie.
 3 Yellow-legged Herring-Gulls (*Larus cachinnans*). Purchased.
 2 Kuhl's Shearwaters (*Puffinus kuhlii*). Purchased.
30. 1 Humboldt's Lagotherix (*Lagotherix humboldti*), ♀. Purchased.
 1 Short-headed Phalanger (*Petaurus breviceps*), ♂. Born in the Menagerie.
 1 Great Eagle-Owl (*Bufo maximus*). From Amoorland. Deposited.
- May 2. 2 Sooty Phalangers (*Trichosurus fuliginosus*). Presented by A. Waley, Esq.
 3. 1 Common Chameleon (*Chamaeleon vulgaris*). Deposited.
 4 Common Vipers (*Vipera berus*). Presented by Mr. J. Amos.
 4. 6 Garganey Teal (*Querquedula circia*), 3 ♂, 3 ♀. Purchased.
 7. 1 Mountain Zebra (*Equus zebra*), ♀. Purchased. See P. Z. S. 1898, p. 456.
 1 Salvadori's Cassowary (*Casuarius salvadorii*?). Deposited.
 1 Glaucous Macaw (*Anodorhynchus glaucus*). Deposited.
10. 1 Rhesus Monkey (*Macacus rhesus*), ♀. Presented by Mr. W. H. Lewis.
 1 Banded Parrakeet (*Palaornis fasciata*), ♂. Presented by Lady Lumsden.
 1 Banded Parrakeet (*Palaornis fasciata*), ♂. Deposited.
 1 Cardinal Grosbeak (*Cardinalis virginianus*), ♂. Presented by Mrs. Harry Blades.
11. 2 Black-backed Geese (*Sarcidiornis melanota*), ♂ ♀. Received in Exchange.
 2 Grey-lag Geese (*Anser cinereus*). Received in Exchange.
 1 Macaque Monkey (*Macacus cynomolgus*), ♂. Presented by Mrs. Eyre.
 2 Crested Screamers (*Chauna cristata*). Purchased.
12. 2 Scaly-breasted Lorikeets (*Psittentulus chlorolepidotus*). Purchased.
13. 1 Red-backed Buzzard (*Buteo erythronotus*). Presented by Ernest Hartley, Esq.
16. 2 Japanese Deer (*Cervus sika*), ♂ ♀. Born in the Menagerie.
17. 1 Vervet Monkey (*Cercopithecus lalandii*), ♂. Presented by Mr. C. J. Barratt.
 1 Common Raccoon (*Procyon lotor*). Presented by A. D. Jenkins, Esq.
 1 Orange-winged Amazon (*Chrysotis amazonica*). Deposited.
 2 Blue-fronted Amazons (*Chrysotis aestiva*). Deposited.
 1 Guinea Baboon (*Cynocephalus sphinx*), ♂. Presented by Capt. H. de la Cour Travers.
18. 1 Guillemot (*Lomvia troile*). Presented by Ernest Horne, Esq.
 3 Shaw's Gerbilles (*Gerbillus shawi*). Born in the Menagerie.
20. 1 Barbary Ape (*Macacus inuus*), ♂. Presented by E. L. Cooke, Esq.
 1 Leucoryx Antelope (*Oryx leucoryx*), ♂. Purchased. See P. Z. S. 1898, p. 456.

- May 20. 1 Red-winged Parrakeet (*Ptilines erythropterus*). Received in Exchange.
 1 Long-billed Butcher-bird (*Cracticus destructor*). Received in Exchange.
 1 Red River-Hog (*Potamochoærus pencillatus*), ♂. Purchased.
21. 1 Reindeer (*Rangifer tarandus*), ♂. Presented by Capt. the Hon. M. A. Bourke, R.N., H.M.S. 'Cordelia.' See P. Z. S. 1898, p. 456.
 1 Beccari's Cassowary (*Casuarius beccarii*?). Deposited.
 1 Orange-winged Amazon (*Chrysotis amazonica*). Deposited.
22. 1 Mocassin Snake (*Tropidonotus fasciatus*). Presented by James Meldrum, Esq., F.Z.S.
23. 1 Black-tailed Gazelle (*Gazella tilonura*), ♂. Deposited.
 1 Beccari's Cassowary (*Casuarius beccarii*). Deposited.
 1 Short-headed Phalanger (*Petaurus breviceps*), ♀. Presented by Julian T. Pym, Esq.
 1 Small Hill-Mynah (*Gracula religiosa*). Presented by Mrs. Strather.
24. 1 Smooth Snake (*Coronella austriaca*). Presented by Bryan Hook, Esq.
 1 Annulated Squirrel (*Sciurus annulatus*). Presented by W. H. Boyle, Esq.
 3 Schlegel's Doves (*Calopelia puella*). Presented by W. H. Boyle, Esq.
25. 2 Black-striped Wallabies (*Macropus dorsalis*), ♂ ♀. Deposited.
 1 Black-shouldered Kite (*Elanus cæruleus*).
 1 Tachiro Goshawk (*Astur tachiro*).
 1 Spotted Eagle-Owl (*Bubo muculosus*).
 2 Infernal Snakes (*Boodon infernalis*).
 2 Lineated Snakes (*Boodon lineatus*).
 1 Smooth-bellied Snake (*Homalosoma lutrix*).
 4 Rough-keeled Snakes (*Dasypeltis scabra*).
 11 Rufescent Snakes (*Leptodira hotambœia*).
 4 Rhomb-marked Snakes (*Trimerorhinus rhombeatus*).
 15 Crossed Snakes (*Psammodphis crucifer*).
 1 Cape Adder (*Bitis atropos*).
 3 Puff-Adders (*Bitis arietans*).
26. 1 African Wild Ass (*Equus tæniopus*), ♂. Born in the Menagerie.
 1 Gazelle (*Gazella dorcas*), ♂. Presented by F. D. Lambert, Esq.
 2 Mantchurian Cranes (*Grus japonensis*). Purchased.
 2 Malabar Squirrels (*Sciurus maximus dealbatus*). Presented by R. C. Wroughton, Esq.
27. 2 Barbary Wild Sheep (*Ovis tragelaphus*). Born in the Menagerie.
 1 Sharp-nosed Crocodile (*Crocodylus americanus*). Deposited.
 1 Algerian Tortoise (*Testudo iberæ*). Presented by Mr. Albert West.
28. 1 Canadian Skunk (*Mephitis mephitis*). Deposited.
 1 Florida Tortoise (*Testudo polyphemus*). Deposited.
 1 Collared Peccary (*Dicotyles tajaçu*). Presented by Eustace Grey, Esq.
 2 Black-necked Swans (*Cygnus nigricollis*). Bred in the Menagerie. See P. Z. S. 1898, p. 456.

- May 30. 1 English Wild Bull (*Bos taurus*), ♂. Born in the Menagerie.
31. 1 Angural Buzzard (*Buteo anguralis*). Deposited.
 2 Egyptian Kites (*Milvus aegyptius*). Presented by the Rev. R. H. C. Graham.
 1 Double-ringed Turtle-Dove (*Turtur bitorquatus*). Purchased.
- June 1. 1 Burchell's Zebra (*Equus burchelli*), ♂. Deposited.
 1 Bean-Goose (*Anser segetum*), ♂. Presented by W. H. St. Quintin, Esq., F.Z.S.
 2. 1 Yellow-billed Sheath-bill (*Chionis alba*). Presented by Capt. H. W. Schlemann.
 2 Golden Eagles (*Aquila chrysaetus*). Presented by Edgar Baxter, Esq.
 1 Common Viper (*Vipera berus*). Presented by John Harris, Esq.
 4. 2 Black-billed Hornbills (*Lophoceros nasutus*). Purchased.
 1 Greater Sulphur-crested Cockatoo (*Cacatua galerita*). Presented by G. P. Dupuch, Esq.
 1 Yarrell's Curassow (*Crax carunculata*), ♀. Purchased.
 1 White-eyebrowed Guan (*Penelope superciliosa*). Purchased.
 1 Servaline Cat (*Felis servalina*). From Uganda. Presented by Francis G. Hall, Esq.
 1 Serval (*Felis serval*). From Uganda. Presented by Francis G. Hall, Esq.
 6. 1 Dorsal Squirrel (*Sciurus hypopyrrhus*). Presented by Miss Trelawny.
 7. 1 Macaque Monkey (*Macacus cynomolgus*), ♂. Presented by Miss Nellie Biggs.
 1 Ring-necked Pheasant (*Phasianus torquatus*), ♂. Presented by Dr. C. Danford Thomas, F.Z.S.
 4 Wonga-Wonga Pigeons (*Leucosarcia picata*). Purchased.
 1 Indranee Owl (*Syrnium indranee*). Deposited.
 8. 2 Italian Newts (*Molge italica*). Presented by Count M. G. Peracca, F.Z.S.
 9. 1 Pin-tailed Whydah-bird (*Vidua principalis*), ♂. Presented by M^{me}. Café.
 1 Florida Tortoise (*Testudo polyphemus*). Deposited.
 1 Eyed Lizard (*Lacerta ocellata*). Presented by H. F. Witherby, Esq., F.Z.S.
 10. 4 Azara's Opossums (*Didelphys azarae*). Purchased.
 1 Naked-throated Bell-bird (*Chasmorhynchus nudicollis*). Purchased.
 1 Burrowing-Owl (*Speotyto cunicularia*). Purchased.
 11. 2 Mexican Guans (*Ortalis vetula*). Purchased.
 1 Rough Terrapin (*Nicoria punctularia*). Purchased.
 1 Sarus Crane (*Grus antigone*). Purchased.
 1 Four-lined Snake (*Coluber quatorlineatus*). Purchased.
 1 Angulated Snake (*Helicops angulatus*). Purchased.
 13. 1 Cape Zorilla (*Ictonyx zorilla*). Presented by J. E. Matcham, Esq., C.M.Z.S.
 1 Dusty Ichneumon (*Herpestes pulverulentus*). Presented by J. E. Matcham, Esq., C.M.Z.S.
 4 Fieldfares (*Turdus pilaris*). From Christiansund. Presented by Dr. R. B. Sharpe, F.Z.S.
 1 Black Guillemot (*Uria grylle*). From Christiansund. Presented by Dr. R. B. Sharpe, F.Z.S.
 1 Crowned Partridge (*Rollulus cristatus*), ♂. Purchased.

- June 13. 3 Triangular-spotted Pigeons (*Columba guinea*). Bred in the Menagerie.
- 12 Algerian Skinks (*Eumeces algeriensis*). Presented by Robert S. Hunter, Esq.
- 2 Forster's Lung-fish (*Ceratodus forsteri*). Purchased. See P. Z. S. 1898, p. 586.
- 2 Forster's Lung-fish (*Ceratodus forsteri*). Deposited.
14. 1 Guinea Baboon (*Cynocephalus sphinx*), ♀. Presented by Capt. C. C. Wyatt.
- 1 Indian Python (*Python molurus*). Presented by Percival F. Tuckett, Esq.
- 1 Four-lined Snake (*Coluber quatorlineatus*). Presented by W. R. Temple, Esq.
- 4 Common Comorants (*Phalacrocorax carbo*). Purchased.
15. 1 Malabar Squirrel (*Sciurus maximus dealbatus*). Deposited.
- 3 Common Marmosets (*Hapale jacchus*). Presented by Col. A. H. Maclean.
16. 1 Naked-footed Owllet (*Athene noctua*). Presented by The Hon. Mrs. Barrington.
- 2 Senegal Parrots (*Pseocephalus senegalus*). Presented by Miss E. L. Barford.
17. 2 Cereopsis Geese (*Cereopsis novæ-hollandiæ*), ♂ ♀. Purchased.
18. 2 White-tailed Gnus (*Connochaetes gnu*), ♂ ♀. Presented by C. D. Rudd, Esq., F.Z.S. See P. Z. S. 1898, p. 586.
- 1 Spotted Eagle-Owl (*Bubo maculosus*). Presented by J. E. Matcham, Esq., C.M.Z.S.
- 2 South-African Kestrels (*Tinnunculus rupicola*). Presented by C. Southey, Esq.
20. 2 Dusky Francolins (*Pternistes infuscatus*). Purchased.
- 1 Madagascar Tree-Boa (*Corallus madagascariensis*). Purchased.
- 2 Yellow-cheeked Lemurs (*Lemur xanthomystax*). Deposited.
21. 1 Macaque Monkey (*Macacus cynomolgus*), ♂. Presented by Miss Stankowski.
- 1 Sykes's Monkey (*Cercopithecus albigularis*), ♀. Presented by Miss Gladys Carey.
- 1 Great Anteater (*Myrmecophaga jubata*). Purchased.
22. 1 Hybrid Zebra (between *Equus caballus* ♂ and *Equus burchelli* ♀). Born in the Menagerie.
- 1 Brush-tailed Kangaroo (*Petrogale penicillata*), ♂. Presented by C. J. Leyland, Esq., F.Z.S.
- 1 Blue-fronted Amazon (*Chrysotis æstiva*). Deposited.
23. 1 White-tailed Gnu (*Connochaetes gnu*), ♂. Born in the Menagerie.
- 2 Thars (*Hemitragus jemlaicus*), ♂ ♀. Born in the Menagerie.
- 6 Algerian Tortoises (*Testudo iberæ*). Deposited.
- 2 Red-and-Yellow Macaws (*Ara chloroptera*). Received in Exchange.
24. 2 Red-backed Pelicans (*Pelecanus rufescens*). From the Niger River. Presented by H. L. Bernstein, Esq.
- 2 Madagascar Tree-Boas (*Corallus madagascariensis*). Deposited.
25. 1 Banded Ichneumon (*Crossarchus fasciatus*). Deposited.
- 1 Tamandua Anteater (*Tamandua tetradactyla*). Purchased.
- 2 White-necked Storks (*Dissura episcopus*). Purchased.
- 1 Dusky Trumpeter (*Psophia obscura*). Purchased.
- 1 Black Hangnest (*Cassidix oryzivora*). Presented by R. Phillips, Esq.

- June 25. 1 Angulated Tortoise (*Testudo angulata*). Deposited.
27. 1 Chimpanzee (*Anthropopithecus troglodytes*), ♀. Deposited.
 1 Bonnet-Monkey (*Macacus sinicus*), ♂. Presented by the Lady Tichborne.
 1 Mouflon (*Ovis musimon*), ♂. Presented by H. Brinsley Brooke, Esq.
 1 Brush-Turkey (*Talegalla lathamii*). Purchased.
 1 Royal Python (*Python regius*). Presented by W. G. Woodrow, Esq.
28. 2 Bennett's Wallabies (*Macropus bennetti*), ♂ ♀. Born in the Menagerie.
 1 Brush-tailed Kangaroo (*Petrogale penicillata*), ♀. Born in the Menagerie.
 1 Glaucous Macaw (*Anodorhynchus glaucus*). Deposited.
 1 Jackal Buzzard (*Buteo jacal*). Presented by J. E. Matcham, Esq., C.M.Z.S.
 5 Upland Geese (*Chloëphaga magellanica*). Bred in the Menagerie.
29. 1 Yellow-crowned Penguin (*Eudyptes antipodum*). Deposited.
 1 Thick-billed Penguin (*Eudyptes pachyrhynchus*). Deposited.
 6 Argentine Tortoises (*Testudo argentina*). Deposited.
 1 Nilotic Trionyx (*Trionyx triunguis*). Deposited.
 1 White-throated Monitor (*Varanus albigularis*). Deposited.
 1 Japanese Deer (*Cervus sika*), ♀. Born in the Menagerie.
30. 1 Pig-tailed Monkey (*Macacus nemestrinus*), ♀. Presented by J. Ratillon, Esq.
 1 Lioness (*Felis leo*), ♀. From Somaliland. Presented by Henry S. H. Cavendish, Esq.
- July 1. 1 Lesser Koodoo (*Strepsiceros imberbis*), ♂. Purchased. See P. Z. S. 1898, p. 586.
 1 Beisa Antelope (*Oryx beisa*), ♂. Purchased.
 2 Hagenbeck's Jackals (*Canis hagenbecki*). Purchased. See P. Z. S. 1898, p. 586.
 2. 2 Rhesus Monkeys (*Macacus rhesus*), ♂ ♀. Presented by the Park's Committee, Tynemouth.
 1 Bonnet-Monkey (*Macacus sinicus*), ♀. Presented by the Park's Committee, Tynemouth.
 2 Green Monkeys (*Cercopithecus callitrichus*?). Deposited.
 1 Moustache Monkey (*Cercopithecus cephus*), ♀. Deposited.
 1 L'Hoëst's Monkey (*Cercopithecus lhoesti*). Purchased. See P. Z. S. 1898, p. 586, pl. xlviii.
 1 Dusky Trumpeter (*Psophia obscura*). Purchased.
 3 Japanese Teal (*Querquedula formosa*), 1 ♂, 2 ♀. Purchased.
 1 Rufous Rat-Kangaroo (*Aepyprymnus rufescens*), ♂. Purchased.
 2 Black-winged Peafowl (*Pavo nigripennis*), ♂ ♀. Purchased.
 4 Wagler's Terrapins (*Hydraspis wagleri*). Deposited.
4. 4 Wandering Tree-Ducks (*Dendrocygna arcuata*). Purchased.
 2 Vervet Monkeys (*Cercopithecus lalandii*), ♂ ♀. Presented by W. Champion, Esq., F.Z.S.
5. 1 Great Wallaroo (*Macropus robustus*), ♂. Presented by Miss W. Jackson.
 1 Arabian Baboon (*Cynocephalus hamadryas*), ♀. Deposited.
 2 Algerian Hedgehogs (*Erinaceus algirus*). From Tunisia. Presented by Sir Harry Johnston, K.C.B., F.Z.S.
 2 Indian Tantalus (*Pseudotantalus leucocephalus*). Purchased.

- July 5. 1 Puma (*Felis concolor*). Born in the Menagerie.
6. 1 Giraffe (*Giraffa camelopardalis*), ♂. From Senegal. Purchased. See P. Z. S. 1898, p. 587.
- 1 Grey Parrot (*Psittacus erithacus*). Deposited.
- 1 European Pond-Tortoise (*Emys orbicularis*). Presented by A. H. Cocks, Esq., F.Z.S.
- 1 Algerian Tortoise (*Testudo ibera*). Presented by G. K. Gude, Esq., F.Z.S.
7. 1 Shapely Snake (*Phrynonax eutropis*). Presented by R. R. Mole, Esq., C.M.Z.S.
- 1 Deadly Snake (*Lachesis atrox*). Presented by R. R. Mole, Esq., C.M.Z.S.
- 1 Gigantic Centipede (*Scolopendra gigas*). From Trinidad. Presented by R. R. Mole, Esq., C.M.Z.S. See P. Z. S. 1898, p. 587.
- 1 Thick-necked Tree-Boa (*Epicrates cenchris*). Presented by H. Carraciolo, Esq.
- 1 Corais Snake (*Coluber corais*). Presented by H. Carraciolo, Esq.
- 2 Spotted Pigeons (*Columba maculosa*). Purchased.
- 2 Yellowish Finches (*Sycalis luteola*). Presented by Mr. F. L'Hoëst, C.M.Z.S.
8. 2 Barbary Wild Sheep (*Ovis tragelaphus*). Born in the Menagerie.
- 1 Burrhel Wild Sheep (*Ovis burrhel*), ♂. Born in the Menagerie.
- 2 Pennant's Parrakeets (*Platycercus elegans*). Deposited.
- 1 Swainson's Lorikeet (*Trichoglossus novæ-hollandiæ*). Deposited.
- 1 Lataste's Viper (*Vipera latastii*). Presented by Mr. Carl Hagenbeck.
- 8 Lateral White-eyes (*Zosterops lateralis*). Purchased.
9. 1 Burmeister's Cariama (*Chunga burmeisteri*). Purchased.
11. 1 Japanese Deer (*Cervus sika*), ♂. Born in the Menagerie.
- 2 Thick-billed Penguins (*Eudyptes pachyrhynchus*). Deposited.
- 1 Jardine's Parrot (*Pæocephalus gularis*). Deposited.
- 5 Ruffs (*Machetes pugnax*), 2 ♂, 3 ♀. Purchased.
- 2 Redshanks (*Totanus calidris*). Purchased.
12. 1 Japanese Deer (*Cervus sika*), ♀. Born in the Menagerie.
- 1 Grey Parrot (*Psittacus erithacus*). Presented by Mr. Palmer.
- 2 Spoonbills (*Platalea leucorodia*). Purchased.
- 2 Axolotls (*Amblystoma tigrinum*). Presented by W. R. Temple, Esq.
13. 1 Lion (*Felis leo*), ♀. Presented by P. B. Vanderbyl, Esq.
- 1 Cardinal Grosbeak (*Cardinalis virginianus*), ♂. Presented by Mrs. Chambers.
- 2 Shags (*Phalacrocorax graculus*). Presented by the Maclaine of Lochbuie.
- 10 Common Chameleons (*Chamaleon vulgaris*). Purchased.
14. 1 Chacma Baboon (*Cynocephalus porcaricus*), ♂. Presented by Dr. Suffield.
- 1 Brown Capuchin (*Cebus futuellus*). Presented by Mrs. Wallace, F.Z.S.
- 3 European Pond-Tortoises (*Emys orbicularis*). Presented by Miss E. Endicott.
15. 1 Macaque Monkey (*Macacus cynomolgus*). Born in the Menagerie.
- 2 Australian Bell-birds (*Manorhina melanophrys*). Deposited.

- July 15. 2 Elephantine Tortoises (*Testudo elephantina*). Deposited.
 1 Clumsy Tortoise (*Testudo inepta*). Deposited.
 1 Round-spotted Lizard (*Stenodactylus guttatus*). Presented by Master R. Stradling.
16. 5 Bridled Wallabies (*Onychogale frenata*), 2 ♂, 3 ♀. Purchased.
 2 Orang-outangs (*Simia satyrus*), ♂ ♀. Purchased.
 1 Maguari Stork (*Dissura maguari*). Deposited.
 1 Gentoo Penguin (*Pygosceles taniatus*). Deposited.
 1 Squirrel-monkey (*Chrysothrix sciurea*). Deposited.
17. 1 Common Chameleon (*Chamaeleon vulgaris*). Presented by Clyde Hinshelwood, Esq.
 2 Common Snakes (*Tropidonotus natrix*). Presented by A. Waley, Esq.
19. 1 Naked-footed Owllet (*Athene noctua*). Presented by the Hon. Walter Rothschild, F.Z.S.
 2 Coquerel's Mouse-Lemurs (*Cheirogaleus coquereli*). Deposited.
 10 Algerian Tortoises (*Testudo iberæ*). Deposited.
 1 Glass Snake (*Ophiosaurus apus*). Deposited.
 1 Black-marked Snake (*Coluber scalaris*). Deposited.
 1 Ravergier's Snake (*Zamenis ravergeri*). Deposited.
20. 19 Saddle-backed Tortoises (*Testudo ephippium*). From Duncan Island, Galapagos Group. Deposited. See P. Z. S. 1898, p. 587.
 33 South-Albemarle Tortoises (*Testudo vicina*). From Albemarle Island, Galapagos Group. Deposited. See P. Z. S. 1898, p. 587.
 4 Speckled Terrapins (*Clemmys guttata*). Deposited.
 37 Painted Terrapins (*Chrysemys picta*). Deposited.
 2 American Box-Tortoises (*Cistudo carolina*). Deposited.
 1 Stink-pot Mud-Terrapin (*Cinosternon odoratum*). Deposited.
 2 Alligator Terrapins (*Chelydra serpentina*). Deposited.
 5 Golden Carp (*Carassius auratus*), var. Presented by F. H. Fitz-Roy, Esq.
21. 1 Graceful Ground-Dove (*Geopelia cuneata*). Purchased.
 2 Peaceful Ground-Doves (*Geopelia tranquilla*), ♂ ♀. Purchased.
23. 1 Bridled Wallaby (*Onychogale frenata*), ♂. Deposited.
25. 1 Rook (*Corvus frugilegus*). Presented by Mr. Mack.
 1 Vinaceous Amazon (*Chrysotis vinacea*). Deposited.
26. 4 Cambayan Turtle-Doves (*Turtur senegalensis*). Bred in the Menagerie.
 1 Spotted Pigeon (*Columba maculosa*). Bred in the Menagerie.
 3 Wrinkled Terrapins (*Chrysemys scripta rugosa*). Deposited.
27. 1 Pig-tailed Monkey (*Macacus nemestrinus*), ♀. Presented by C. R. Johnson, Esq.
 1 Common Rat-Kangaroo (*Potorous tridactylus*), ♂. Presented by Major Fleming.
 1 Humboldt's Saki (*Pithecia monachus*). Deposited.
28. 1 White-crested Jay-Thrush (*Garrulax leucolophus*). Presented by Henry Fulljames, Esq.
 1 White-throated Jay-Thrush (*Garrulax albogularis*). Presented by Henry Fulljames, Esq.
29. 2 Squirrel Monkeys (*Chrysothrix sciurea*). Presented by C. E. Günther, Esq.
 1 Orange-winged Amazon (*Chrysotis amazonica*). Deposited.

- July 29. 1 Festive Amazon (*Chrysotis festiva*). Deposited.
 5 Gazelles (*Gazella dorcas*). Deposited.
 1 Leopard Tortoise (*Testudo pardalis*). Presented by Capt. E. M. Woodward.
 1 Bell's Cinixys (*Cinixys belliana*). Presented by Capt. E. M. Woodward.
 1 Home's Cinixys (*Cinixys homeana*). Presented by Capt. E. M. Woodward.
30. 1 Common Chameleon (*Chamæleon vulgaris*). Presented by W. Cooper, Esq.
31. 2 Magpies (*Pica rustica*). Deposited.
- Aug. 2. 1 Squirrel Monkey (*Chrysothrix sciurea*). Presented by W. R. Routledge, Esq.
 1 Garden Dormouse (*Myoxus quercinus*). Received in Exchange.
 1 Common Wombat (*Phascolomys mitchelli*). Deposited.
 2 Mailed Uromastix (*Uromastix loricatus*). Deposited.
 1 Blackish Sternotherere (*Sternothererus nigricans*). Deposited.
 1 Wrinkled Terrapin (*Chrysemys scripta rugosa*). Deposited.
 3 Amphiumas (*Amphiuma means*). Deposited.
 1 Ochraceous Ichneumon (*Herpestes ochraceus*). From Somaliland. Presented by R. M. Hawker, Esq., F.Z.S.
 1 Abyssinian Guinea-fowl (*Numida ptilorhyncha*). From Somaliland. Presented by R. M. Hawker, Esq., F.Z.S.
3. 1 Red-masked Conure (*Conurus rubrolarvatus*). Presented by Mrs. E. Heurey.
 1 Spiny-tailed Iguana (*Ctenosaura acanthura*). Deposited.
4. 1 Mozambique Monkey (*Cercopithecus pygerythrus*), ♀. Presented by Miss Ethel Ansoerge.
 1 Wapiti Deer (*Cervus canadensis*), ♂. Born in the Menagerie.
 1 Raven (*Corvus corax*). Presented by H. W. Mansell, Esq.
5. 1 American Siskin (*Chrysomitris tristis*). Deposited.
6. 2 Yellow-bellied Liothrix (*Liothrix luteus*).
 1 Superb Tanager (*Calliste fastuosa*).
 1 Australian Waxbill (*Estrelida temporalis*).
 5 Amaduvade Finches (*Estrelida amandava*).
 1 Modest Grass-Finch (*Amadina modesta*).
 2 Orange-cheeked Waxbills (*Estrelida melopoda*).
 1 Crimson-eared Waxbill (*Estrelida phœnicotis*).
 2 Chestnut-eared Finches (*Amadina castanotis*).
 3 Bar-breasted Finches (*Munia nisoria*).
 1 Black-headed Finch (*Munia malacca*).
 1 Indian Silver-bill (*Munia malabarica*).
 4 Indian Silver-bills (var.) (*Munia malabarica*).
 2 Banded Grass-Finches (*Poëphila cineta*).
 1 Parrot Finch (*Erythrura psittacea*).
 1 Shining Weaver-bird (*Hypochera nitens*).
 1 Grenadier Weaver-bird (*Euplectes oryx*).
 1 Black-bellied Weaver-bird (*Euplectes afer*).
 2 Lazuline Finches (*Guiraca parellina*).
 2 Red-crested Finches (*Coryphospingus cristatus*).
 1 Yellow-rumped Seed-eater (*Crithagra chrysopyga*).
 2 Passerine Parrots (*Psittacula passerina*).
 2 Grey-headed Love-birds (*Agapornis cana*).

Presented by
 A. Aitchison,
 Esq., F.Z.S.

- Aug. 7. 1 Wapiti Deer (*Cervus canadensis*), ♂. Born in the Menagerie.
 8. 2 Three-toed Sloths (*Bradypus tridactylus*), ♀ et juv. Purchased.
 9. 1 Common Chameleon (*Chamæleon vulgaris*). Presented by M. Titford, Esq.
 10. 1 Humboldt's Lagothrix (*Lagothrix humboldti*). Received in Exchange.
 1 Red-backed Saki (*Pithecia chiropotes*). Received in Exchange.
 11. 1 Rhesus Monkey (*Macacus rhesus*), ♀. Presented by C. E. Bashall, Esq.
 1 Grey Parrot (*Psittacus erithacus*). Deposited.
 1 Smooth-bellied Snake (*Homalosoma lutrix*).
 1 Rufescent Snake (*Leptodira hotambæia*).
 2 Rhomb-marked Snakes (*Trimerorhinus rhombeatus*).
 5 Crossed Seakes (*Psammophis crucifer*).
 3 Puff-Adders (*Bitis arietans*). } Presented by J. E. Matcham, Esq., C.M.Z.S.
 12. 2 Pinche Monkeys (*Midas adipus*). Deposited.
 13. 1 Bonnet-Monkey (*Macacus sinicus*), ♀. Presented by Mr. H. Page.
 15. 1 Reticulated Python (*Python reticulatus*). Deposited.
 1 Tiger (*Felis tigris*). Deposited.
 1 Leopard (var.) (*Felis pardus*). Deposited.
 1 Crested Pigeon (*Ocyphaps lophotes*). Bred in the Menagerie.
 6 Californian Quails (*Callipepla californica*). Bred in the Menagerie.
 16. 1 Bonnet-Monkey (*Macacus sinicus*), ♂. Presented by Miss Emily Sandell.
 1 Macaque Monkey (*Macacus cynomolgus*), ♂. Presented by Madame Giorgi.
 1 Rhesus Monkey (*Macacus rhesus*), ♀. Presented by Miss Leathes.
 1 Grand Eclectus (*Eclectus roratus*). Presented by Mrs. Peter Watson.
 1 Corais Snake (*Coluber corais*). Presented by Cecil W. Lilley, Esq., F.Z.S.
 17. 1 Chimpanzee (*Anthropopithecus troglodytes*), ♀. Deposited.
 1 Burrhel Wild Sheep (*Ovis burrhel*). Born in the Menagerie.
 1 Elephantine Tortoise (*Testudo elephantina*). Deposited.
 18. 1 Sykes's Monkey (*Cercopithecus albigularis*), ♀. Presented by C. Carter, Esq.
 1 Red-bellied Wallaby (*Macropus billardieri*), ♂. Deposited.
 19. 1 Charles-Island Tortoise (*Testudo gigantea*). Deposited.
 20. 2 Maximilian's Aracaris (*Pteroglossus wiedi*). Purchased.
 3 Lettered Aracaris (*Pteroglossus inscriptus*). Purchased.
 3 Golden-headed Conures (*Conurus auricapillus*). Purchased.
 2 Red-underwinged Doves (*Leptoptila rufuzilla*). Purchased.
 2 Red Ground-Doves (*Geotrygon montana*). Purchased.
 1 Little Guan (*Ortalis motmot*). Purchased.
 6 Superb Tanagers (*Calliste fastuosa*). Purchased.
 4 Brazilian Hangnests (*Icterus jamaicai*). Purchased.
 3 Merrem's Snakes (*Rhadinæa merremi*). Purchased.
 22. 1 African Civet (*Viverra civetta*). Presented by Lieut. Carroll and Major Arthur Festing.
 1 Indian Chevrotain (*Tragulus meminna*), ♂. Purchased.
 2 Indian Pythons (*Python molurus*). Deposited.
 25. 1 Fat-tailed Sheep (*Ovis aries*, var.), ♂. Presented by the Hon. Sir J. Sivewright, K.C.M.G.

- Aug. 25. 2 Alligators (*Alligator mississippiensis*). Presented by O. Moser, Esq.
26. 1 Bosch-bok (*Tragelaphus sylvaticus*).
 2 Maholi Galagos (*Galago maholi*).
 2 Cape Zorillas (*Ictonyx zorilla*).
 1 Hoary Snake (*Pseudaspis cana*).
 12 Crossed Snakes (*Psammodphis crucifer*).
 2 Rough-keeled Snakes (*Dasypeltis scabra*).
 2 Rufescent Snakes (*Leptodira hotambœia*).
 2 Smooth-bellied Snakes (*Homalosoma lutrix*).
 2 Puff-Adders (*Bitis arietans*).
 1 Brown Gannet (*Sula leucogastra*). Presented by Capt. Ernest W. Burnett.
- 1 Reticulated Python (*Python reticulatus*). Deposited. See P. Z. S. 1898, p. 587.
- 12 African Walking-fish (*Periophthalmus koelreuteri*). Presented by Dr. H. O. Forbes, F.Z.S. See P. Z. S. 1898, p. 587.
27. 1 Common Viper (*Vipera berus*). Presented by W. F. Blandford, Esq.
 2 Common Snakes (*Tropidonotus natrix*). Presented by W. F. Blandford, Esq.
 1 Burrhel Wild Sheep (*Ovis burrhel*), ♀. Born in the Menagerie.
29. 1 Brazilian Hangnest (*Icterus jamaicai*). Presented by Percy M. Calder, Esq.
 1 White-throated Finch (*Spermophila albogularis*). Presented by Percy M. Calder, Esq.
 5 Rufous Tinamous (*Rhynchotus rufescens*). Presented by Ernest Gibson, Esq.
30. 2 Great Kangaroos (*Macropus giganteus*), ♂ ♀. Deposited.
 2 Great Wallaroos (*Macropus robustus*). Deposited.
 2 Bennett's Wallabies (*Macropus bennetti*). Deposited.
 2 Brush-tailed Kangaroos (*Petrogale penicillata*). Deposited.
 1 Red-bellied Wallaby (*Macropus billardieri*). Deposited.
 1 Dormouse Phalanger (*Dromicia nana*). Received in Exchange.
- 11 Brush-Turkeys (*Talegalla lathamii*). Deposited.
- 12 Roseate Cockatoos (*Cacatua roseicapilla*). Deposited.
 6 Greater Sulphur-crested Cockatoos (*Cacatua galerita*). Deposited.
 5 Silky Bower-birds (*Ptilonorhynchus violaceus*). Received in Exchange.
- 1 Humboldt's Lagothrix (*Lagothrix humboldti*). Presented by C. H. L. Ewen, Esq.
 2 Augural Buzzards (*Buteo auguralis*). Presented by Dr. Chalmers.
 3 Goliath Beetles (*Goliathus druryi*). Presented by Dr. Chalmers.
 1 Lazuline Finch (*Guiraca parellina*). Presented by John B. Toone, Esq.
 1 Elegant Lizard (*Uta elegans*). Presented by John B. Toone, Esq.
 2 Elephantine Tortoises (*Testudo elephantina*). Deposited.
31. 1 Hoolock Gibbon (*Hylobates hoolocki*), ♀. Presented by Lionel Inglis, Esq.

Presented by
 J. E. Matcham,
 Esq., C.M.Z.S.

- Aug. 31. 1 Grenadier Weaver-bird (*Euplectes oryx*). Presented by Mrs. Frances A. Cock.
 1 Common Snake (*Tropidonotus natrix*). Presented by A. S. Shrubbs, Esq.
- Sept. 1. 1 Ganga Cockatoo (*Callocephalon galeatum*). Deposited.
 2. 1 Rüppell's Colobus (*Colobus guereza*). Presented by Mr. Justice Kelly. See P. Z. S. 1898, p. 587.
 1 Duke of Bedford's Deer (*Cervus xanthopygius*). Presented by H.G. the Duke of Bedford, F.Z.S. See P. Z. S. 1898, p. 588.
 1 Brown-necked Parrot (*Pæocephalus fuscicollis*). Deposited.
 2 Prêtre's Amazons (*Chrysotis prætrii*). Deposited.
 1 Red-vented Parrot (*Pionus menstruus*). Deposited.
 1 Iceland Falcon (*Hierofalco islandus*). Presented by C. R. Anderson, Esq.
5. 1 Chacma Baboon (*Cynocephalus porcarius*), ♀. From the Cape. Presented by J. E. Matcham, Esq., C.M.Z.S.
 2 Egyptian Geese (*Chenalopez ægyptiacus*). From the Cape. Presented by J. E. Matcham, Esq., C.M.Z.S.
 1 Kinkajou (*Cercoleptes caudivolvulus*), ♂. Purchased.
6. 1 Leopard (*Felis pardus*). Deposited.
7. 1 Festive Amazon (*Chrysotis festiva*). Deposited.
8. 11 Long-eared Bats (*Plecotus auritus*). Presented by F. Cane, Esq.
 1 Nose-horned Viper (*Bitis nasicornis*). Deposited.
9. 2 Spotted Cavies (*Cælogenyx paca*). Deposited.
 1 Punctated Agouti (*Dasyprocta punctata*). Deposited.
 1 Ring-tailed Coati (*Nasua rufa*). Deposited.
 1 Kinkajou (*Cercoleptes caudivolvulus*). Deposited.
 6 Spiny-tailed Iguanas (*Ctenosaura acanthura*). Deposited.
 1 Delalande's Gecko (*Tarentola delalandii*). Deposited.
 1 Stanleyan Chevrotain (*Tragulus stanleyanus*), ♂. Presented by Miss Norah F. L. Briggs.
10. 1 Plumbeous Snake (*Oxyrhopus clælia*). Deposited.
 2 Hawk-billed Turtles (*Chelone imbricata*). Presented by H. Skinner, Esq.
12. 3 Swinhoe's Pheasants (*Euplocamus swinhoii*). Bred in the Menagerie.
 3 Mandarin Ducks (*Aix galericulata*). Bred in the Menagerie.
13. 1 Vociferous Sea-Eagle (*Haliaëtus vocifer*). Deposited.
14. 1 Ring-tailed Coati (*Nasua rufa*). Presented by S. C. Rogers, Esq.
 1 Common Chameleon (*Chamæleon vulgaris*). Deposited.
15. 1 Pleasant Antelope (*Tragelaphus gratus*), ♀. Purchased.
 2 Little Armadillos (*Dasypus minutus*). Deposited.
16. 1 Crested Porcupine (*Hystrix cristata*). Born in the Menagerie.
19. 1 Rhesus Monkey (*Macacus rhesus*), ♀. Presented by Charles Ganz, Esq.
 1 Brown Capuchin (*Cebus fatuellus*). Presented by Miss May Hill.
20. 3 Black-eared Marmosets (*Hapale penicillata*), ♂ ♀ et juv. Presented by Mrs. Dal Young.
 2 White-throated Capuchins (*Cebus hypoleucus*). Presented by Mrs. E. C. Cregan.
23. 1 Red-vented Bulbul (*Pycnonotus hæmorrhous*). Deposited.
 1 Common Chameleon (*Chamæleon vulgaris*). Presented by W. E. Reymes-Cole, Esq.

- Sept. 23. 1 Chimpanzee (*Anthropopithecus troglodytes*), ♂. Presented by Claude E. Birch, Esq.
26. 3 Lions (*Felis leo*), 1 ♂, 2 ♀. Presented by Arthur Henry Sharpe, Esq., F.Z.S., and Ewart Scott Grogan, Esq., F.Z.S.
- 1 Sumatran Rhinoceros (*Rhinoceros sumatrensis*), ♀. Purchased.
- 2 Reticulated Pythons (*Python reticulatus*). Deposited.
27. 6 Spotted Tinamous (*Nothura maculosa*). Presented by Ernest Gibson, Esq.
28. 2 Emus (*Dromæus novæ-hollandiæ*). Deposited.
- 1 Black-winged Grackle (*Gracupica melanoptera*). Deposited.
- 10 Cunningham's Skinks (*Egernia cunninghami*). Deposited.
- 1 Black-and-Yellow Cyclodus (*Tiliqua nigrolutea*). Deposited.
- 2 Little Ringed Plovers (*Egialitis curonica*). Purchased.
- 1 Common Sandpiper (*Tringoides hypoleucus*). Purchased.
29. 1 Ring-tailed Coati (*Nasua rufa*). Presented by W. C. Way, Esq.
- 1 Red-sided Eclectus (*Eclectus pectoralis*), ♀. Deposited.
- 2 Common Chameleons (*Chamæleon vulgaris*). Presented by Mr. W. F. H. Rosenberg.
30. 1 Nagor Antelope (*Cervicapra redunca*). Deposited.
- 1 Jardine's Parrot (*Pæocephalus gulielmi*). Deposited.
- Oct. 2. 1 Green Monkey (*Cercopithecus callitrichus*). Presented by Cecil Aldin, Esq.
3. 1 Sooty Mangabey (*Cercocebus fuliginosus*), ♀. Presented by Mrs. Penry Lloyd.
4. 1 Reticulated Python (*Python reticulatus*). Deposited.
5. 1 Golden Eagle (*Aquila chrysaëtus*). Presented by the Rev. F. Foxhambert.
6. 1 Indian Wild Dog (*Cyon dukhunensis*), ♂. From N. India. Presented by Surg. Lt.-Col. J. Duke.
- 1 Common Squirrel (*Sciurus vulgaris*). Presented by A. M. Wigram, Esq.
- 1 Egyptian Jerboa (*Dipus ægyptius*). Presented by David Devant, Esq.
- 1 Mozambique Monkey (*Cercopithecus pygerythrus*). Presented by Mrs. Snowdon.
- 1 Radiated Tortoise (*Testudo radiata*). Presented by Master Bertie Standing.
7. 1 Bennett's Gazelle (*Gazella bennetti?*), ♂. Deposited.
- 1 Suricate (*Suricata tetradactyla*). Presented by Mrs. Molteno.
- 1 Black-headed Caique (*Caica melanocephala*). Presented by Mrs. Charles Norton-Dowding.
8. 1 Puma (*Felis concolor*). Presented by Basil J. Freeland, Esq.
11. 2 American Flying-Squirrels (*Sciuropterus volucella*). Presented by Mrs. Nias.
12. 1 Eland (*Oreas canna*), ♂. Purchased.
- 1 Tantalus Monkey (*Cercopithecus tantalus*), ♂. Presented by Arthur T. Warren, Esq.
13. 1 Macaque Monkey (*Macacus cynomolgus*). Presented by Mr. H. W. Mote.
- 1 Black-headed Lemur (*Lemur brunneus*). Deposited.
- 1 Bengalese Cat (*Felis bengalensis*). Presented by Mr. David J. Munro.
- 1 Ruddy Ichneumon (*Herpestes smithi*). Presented by J. Lyons, Esq.

- Oct. 17. 1 Siamese (*Hylobates syndactylus*), ♂. From Negri Sembilan, Malay Peninsula. Presented by Stanley S. Flower, Esq., F.Z.S. See P. Z. S. 1898, p. 588.
- 1 Thick-necked Terrapin (*Bellia crassicollis*). From Kedah, Lower Siam. Presented by Stanley S. Flower, Esq., F.Z.S.
- 1 Amboina Box-Tortoise (*Cyclemys amboinensis*). From Brunei, Borneo. Presented by Stanley S. Flower, Esq., F.Z.S.
- 1 Siamese Terrapin (*Damonia subtrijuga*). From Bangkok, Siam. Presented by Stanley S. Flower, Esq., F.Z.S.
- 1 Burmese Tortoise (*Testudo elongata*). From the Interior of Siam. Presented by Stanley S. Flower, Esq., F.Z.S.
- 1 Rabbit-eared Bandicoot (*Peragale lagotis*). Deposited.
- 1 Vulpine Phalanger (*Trichosurus vulpecula*). Deposited.
- 1 Commom Paradoxure (*Paradoxurus niger*). Presented by H. A. Cottrell, Esq., R.N.R.
- 1 Negro Tamarin (*Midas ursulus*). Presented by E. F. Booker, Esq.
18. 2 Capybaras (*Hydrochærus capybara*). Presented by Basil J. Freeland, Esq.
- 1 Short-winged Weaver-bird (*Hyphantornis brachyptera*), ♂. Presented by Miss Alice Heale.
19. 1 Macaque Monkey (*Macacus cynomolgus*), ♂. Presented by Miss Abchurch.
- 2 Rosy-faced Love-birds (*Agapornis roseicollis*). Bred in the Menagerie.
- 1 Emu (*Dromæus novæ-hollandicæ*). Presented by Sir Cuthbert Peek, Bart., F.Z.S.
20. 1 Suricate (*Suricata tetradactyla*). Presented by Miss F. Peek.
- 6 Mute Swans (*Cygnus olor*). Purchased.
- 2 Starred Tortoises (*Testudo elegans*). Presented by J. Freeman, Esq.
22. 1 Pig-tailed Monkey (*Macacus nemestrinus*), ♀. Presented by R. O. Bell, Esq.
- 1 Smooth-headed Capuchin (*Cebus monachus*), ♀. Deposited.
24. 1 Blue Jay (*Cyanocitta cristata*). Purchased.
- 2 Cockateels (*Calopsittacus novæ-hollandicæ*). Bred in the Menagerie.
- 1 Graceful Ground-Dove (*Geopelia cuneata*). Bred in the Menagerie.
- 1 Spotted Turtle-Dove (*Turtur suratensis*). Bred in the Menagerie.
25. 2 Wild Canaries (*Serinus canarius*). Presented by W. H. St. Quintin, Esq., F.Z.S.
26. 2 Tarantula Spiders (*Mygale*, sp. inc.). Presented by H. R. Taylor, Esq.
27. 1 Common Hamster (albino) (*Cricetus frumentarius*). Deposited.
28. 1 Matamata Terrapin (*Chelys fimbriata*). Deposited.
29. 1 Drill (*Cynocephalus leucophæus*), ♀. Presented by Alfred J. Dempster, Esq.
- 1 Naked-throated Bell-bird (*Chasmorhynchus nudicollis*). Purchased.
- 1 Common Boa (*Boa constrictor*). Purchased.
- 1 Dusky Trumpeter (*Psophia obscura*). From Pará. Presented by Dr. E. A. Goeldi, C.M.Z.S.
31. 1 Ring-tailed Lemur (*Lemur catta*). Deposited.
- 1 Garnett's Galago (*Galago garnetti*). Deposited.
- 1 Serval (*Felis serval*). Presented by H. S. H. Cavendish, Esq.

- Oct. 31. 1 Black-footed Penguin (*Spheniscus demersus*). Presented by H. S. H. Cavendish, Esq.
 1 South-Albemarle Tortoise (*Testudo vicina*). Presented by Capt. C. S. Tindall.
- Nov. 1. 2 Spur-winged Geese (*Plectropterus gambensis*), ♂ ♀. Purchased.
 2 Abyssinian Fruit-Pigeons (*Vinago waalia*). Purchased.
 1 Red-sided Kangaroo (*Dorcopsis rufo-lateralis*). From New Guinea. Deposited.
3. 2 Black-backed Jackals (*Canis mesomelas*). Presented by Lady de Trafford.
 6 Glossy Ibises (*Plegadis falcinellus*). Bred in the Menagerie.
 2 Bar-tailed Godwits (*Limosa lapponica*). Purchased.
4. 1 Bennett's Wallaby (*Macropus bennetti*), ♂. Born in the Menagerie.
 2 Squirrel-like Phalangers (*Petaurus sciureus*), ♂ ♀. Born in the Menagerie.
5. 1 Orange-winged Amazon (*Chrysotis amazonica*). Deposited.
 7. 2 Japanese Deer (*Cervus sika*), 2 ♂. Received in Exchange.
 1 Hamster (var.) (*Ericetus frumentarius*). Deposited.
8. 2 Pumas (*Felis concolor*), ♂ ♀. From the Sierra of Cordoba, Argentine Republic. Presented by Ernest Gibson, Esq.
 2 Elephantine Tortoises (*Testudo elephantina*). Deposited.
 1 Gentoos Penguin (*Pygosceles taniatus*). Deposited.
9. 2 Bennett's Wallabies (*Macropus bennetti*), ♀ et jr. Deposited.
10. 1 Gold Pheasant (*Thaumalea picta*), ♀. Purchased.
13. 1 Axis Deer (*Cervus axis*), ♀. Born in the Menagerie.
15. 1 Hyacinthine Macaw (*Anodorhynchus hyacinthinus*). Purchased.
 2 Red-sided Eclectus (*Eclectus pectoralis*), 2 ♂. Presented by the Chevalier Angelo Luzzatti.
 2 Undulated Grass-Parakeets (*Melopsittacus undulatus*), ♂ ♀. Presented by Arthur J. Finch, Esq.
 1 Booted Eagle (*Nisaetus pennatus*). Presented by Capt. T. E. Marshall, R.A.
 2 Tawny Owls (*Syrnium aluco*). Presented by Mrs. Borrer.
16. 1 Red-fronted Amazon (*Chrysotis vittata*). Presented by G. A. Phillips, Esq.
 1 Ring-necked Parrakeet (*Palæornis torquatus*, var.). Deposited.
 1 Cereopsis Goose (*Cereopsis novæ-hollandiæ*). Presented by Sir Cuthbert Peek, Bart., F.Z.S.
 1 Hobby (*Falco subbuteo*). Purchased.
17. 2 Gold Pheasants (*Thaumalea picta*), ♂ ♀. Presented by W. A. Upton, Esq.
18. 2 Red-bellied Wallabies (*Macropus billardieri*), ♂ ♀. Presented by Major C. J. Urquhart.
19. 2 Vulpine Squirrels (*Sciurus vulpinus*), ♂ ♀. Deposited.
 1 Blue-and-Yellow Macaw (*Ara ararauna*). Presented by W. Murray Guthrie, Esq., F.Z.S.
 1 Red-and-Yellow Macaw (*Ara chloroptera*). Presented by W. Murray Guthrie, Esq., F.Z.S.
21. 1 Yak (*Poëphagus grunniens*), ♀. Born in the Menagerie.
 1 Smith's Dwarf Lemur (*Microcebus smithi*). Deposited.
 1 Crab-eating Opossum (*Didelphys cancrivora*?). Deposited.
 1 Tessellated Snake (*Tropidonotus tessellatus*). Purchased.

- Nov. 22. 1 Diana Monkey (*Cercopithecus diana*), ♀. Presented by Mrs. M. Riach.
 2 One-wattled Cassowaries (*Casuarus uniappendiculatus*). Deposited.
 1 Common Rhea (*Rhea americana*) (white variety). Deposited.
 24. 1 Guinea Baboon (*Cynocephalus sphinx*), ♂. Presented by Capt. Armitage.
 25. 1 Llama (*Lama peruana*), ♀. Born in the Menagerie.
 29. 1 Black Ape (*Cynopithecus niger*). Deposited.
 1 Mozambique Monkey (*Cercopithecus pygerythrus*), ♀. Presented by A. D. Michael, Esq., F.Z.S.
 1 Osprey (*Pandion haliaëtus*). Deposited.
 30. 1 Lesser Vasa Parrot (*Coracopsis nigra*). Deposited.
 1 Dwarf Chameleon (*Chamæleon pumilus*). Presented by Mrs. A. Todd.
- Dec. 1. 1 Bell's Cinixys (*Cinixys belliana*). Deposited.
 1 Home's Cinixys (*Cinixys homeana*). Deposited.
 3 Painted Terrapins (*Chrysemys picta*). Deposited.
 1 Salt-water Terrapin (*Malacoclemmys terrapin*). Deposited.
 3 Reeves's Terrapins (*Damonia reevesi*). Deposited.
 1 Black-headed Terrapin (*Damonia reevesi unicolor*). Deposited.
 4 Caspian Terrapins (*Clemmys caspica*). Deposited.
 1 Japanese Terrapin (*Clemmys japonica*). Deposited.
 4 European Pond-Tortoises (*Emys orbicularis*). Deposited.
 1 Ceylonese Terrapin (*Nicoria trijuga*). Deposited.
 2 Blackish Sternotheres (*Sternotherus nigricans*). Deposited.
 1 Derbian Sternothere (*Sternotherus derbianus*). Deposited.
 1 Spix's Platemyon (*Platemyon spixi*). Deposited.
 1 Dwarf Chameleon (*Chamæleon pumilus*). Presented by Mr. C. Faraday Maypee.
 2. 1 Mantell's Apteryx (*Apteryx mantelli*). Presented by Sir Walter Buller, K.C.M.G., F.R.S.
 3. 1 Common Chameleon (*Chamæleon vulgaris*). Deposited.
 2 Rufescent Snakes (*Leptodira hotambœia*). Deposited.
 5. 1 Axis Deer (*Cervus axis*), ♀. Born in the Menagerie.
 6. 1 African Buzzard (*Buteo desertorum*?). Presented by Capt. E. W. Burnett.
 1 Lanner Falcon (*Falco lanarius*). Presented by Capt. E. W. Burnett.
 7. 2 Scops Owls (*Scops giu*). Deposited.
 1 Rough-keeled Snake (*Dasyplettis scabra*). Presented by H. Oakley, Esq.
 9. 1 Brazilian Tapir (*Tapirus americanus*), ♀. Purchased.
 1 Peregrine Falcon (*Falco peregrinus*). Presented by Capt. Bean.
 2 Common Rattlesnakes (*Crotalus durissus*). Purchased.
 10. 1 Egyptian Jerboa (*Dipus ægyptius*). Presented by Miss Da Costa.
 14. 1 Hocheur Monkey (*Cercopithecus nictitans*), ♂. Deposited.
 16. 2 Nutcrackers (*Nucifraga caryocatactes*). Purchased.
 1 Common Sheldrake (*Tadorna cornuta*), ♀. Purchased.
 17. 2 Red-bellied Squirrels (*Sciurus variegatus*). Presented by Master Lawrence.
 18. 1 Palm-Squirrel (*Sciurus palmarum*). Presented by Dr. G. Lindsay Johnson, F.Z.S.
 19. 1 Triton Cockatoo (*Cacatua triton*). Purchased.

- Dec. 20. 1 Puma (*Felis concolor*). Presented by T. G. Nicholson, Esq.
 1 Red-and-Blue Macaw (*Ara macao*). Presented by H. Sneggitt, Esq.
 1 Gannet (*Sula bassana*). Presented by A. Trevor-Battye, Esq., F.Z.S.
 1 Greek Partridge (*Caccabis saxatilis*). Presented by J. H. Mackenzie, Esq., Lieut. R.N.R.
21. 1 Lapland Bunting (*Calcaricus lapponicus*). Presented by Mr. F. Chatwin.
 1 Reed-Bunting (*Emberiza schæniclus*). Presented by Mr. F. Chatwin.
 6 Gadwalls (*Chaulelasmus streperus*), 3 ♂, 3 ♀. Purchased.
22. 1 Leyland's Colin (*Eupsychortyx leylandi*). Deposited.
 3 Rosy-faced Love-birds (*Agapornis roseicollis*). Bred in the Menagerie.
 1 Hallowell's Tree-Snake (*Dendraspis viridis*). Presented by J. W. Kaye, Esq.
 1 Antillean Boa (*Boa diviniroqua*). Deposited.
23. 2 Black-winged Peafowl (*Pavo nigripennis*), ♂ ♀. Presented by Mrs. Johns.
 3 Horsfield's Tortoises (*Testudo horsfieldi*). Deposited.
24. 1 Urial Wild Sheep (*Ovis vignei*), ♂. Received in Exchange.
27. 1 Rhesus Monkey (*Macacus rhesus*), ♀. Presented by A. Urban Smith, Esq.
 6 Snow-Buntings (*Plectrophenax nivalis*). Purchased.
29. 2 Great Eagle-Owls (*Bubo maximus*). Bred in the Menagerie.

INDEX.

- Abantis**
venosa, 199, 911.
- Ablepharus**
tenuis, 918.
- Acacia**
horrida, 224.
- Acanthodactylus**
savignyi, 916.
- Acanthodon**
lacustris, 507, 508.
robustus, 507, 508.
- Acanthometron**
brevispina, 1025.
catervatum, 1025.
- Acara**
tetrimerus, 492.
- Acartia**
clausii, 543, 546, 549.
longiremis, 541.
 (Dias) *longiremis*, 549.
- Acestra**
gladius, 44.
- Achæa**
lienardi, 422.
- Achantodes**, 595, 707.
cerusicosta, 707.
- Acharana**
similis, 698.
- Achlyodes**
flyas, 367.
- Aclonophlebia**, gen. nov.,
 428.
flavinotata, 428, 444.
- Acolastus**
amyntas, 366.
malvæ, 225.
nigroplagiatus, 224.
pictus, 225.
tuberculatus, 225.
- Acontia**
admota, 421.
- Acraea**
acrita, 53.
aglatonice, 53.
- Acræa**
anacreon, 191, 905.
 —, var. *bomba*, 905.
anemosa, 54, 192, 401.
antinorii, 822.
apecida, 53.
asema, 191, 906.
axina, 905.
bertha, 400.
bræsia, 369, 401.
cabira, 53.
cæcilia, 401.
 —, var. *stenobea*, 401.
caldarena, 191, 906.
chilo, 369, 395, 401.
crystallina, 395, 401.
daira, 400.
doubledayi, 53, 191,
 905.
 —, var. *axina*, 905.
horta, 192, 374.
induna, 191.
lycia, 53, 190, 400.
 —, var. *daira*, 400.
 —, var. *sganzini*, 400.
metaprotea, var. *jack-*
soni, 400.
natalica, 53, 401,
 906.
neobule, 192, 374,
 401.
nero, 191.
nohara, 190, 905.
petræa, 192.
punctatissima, 401.
rakira, 190, 905.
serena, var. *buxtoni*,
 53, 400, 905.
 —, var. *perrupta*, 400,
 822.
sganzini, 400.
stenobea, 401.
violarum, 191, 906.
 —, var. *asema*, 906.
- Acridium**
 sp., 385.
- Acridura**, 598, 670.
dædala, 670.
gryllina, 670, 671.
hadriana, 670.
metalica, 670.
prochyta, 670.
- Acrotylus**
longipes, 384.
- Actias**
luna, 80.
- Actinopus**
harti, 892, 893, 900.
- Actinopyga**
echinites, 836.
excellens, 838.
flavocastanea, 835,
 836, 837.
mauritiana, 835.
parvula, 836, 837,
 838, 848.
 (Mülleria) *echinites*,
 835.
 (—) *mauritiana*, 435.
 (—) *parvula*, 835.
- Acyphas**
robusta, 428.
- Adamsia**
palliatâ, 286.
rondeletii, 286, 311.
- Addax**
naso-maculatus, 352.
- Adeloides**, 599.
- Adena**, 599.
- Adenota**
kob, 850.
- Adopæa**
thamnas, 367.
- Æchmophorus**, 93.
- Ædiodes**
abstrusalis, 653.
bootanalis, 654.
febiliialis, 633.

- Ediodes*
inscitalis, 653.
orbalis, 631.
orientalis, 633.
unipunctalis, 633.
- Ægithus*
clavicornis, 336.
- Ægocera*
leucomelas, 420.
tricolor, 420.
trimeni, 420.
triplagiata, 420.
- Aellopus*
hirundo, 432.
- Ælurus*
fulgens, 130, 131.
- Æschropteryx*
onnustaria, 368.
- Ætheomorpha*
cærulea, 221, 242.
- Ætholix*, 596, 633.
cingalesa, 634.
flavibasalis, 634.
indecisalis, 634.
- Aëthurus*, gen. nov., 450.
glirinus, 451, 454.
- Ætidius*
armatus, 541, 542, 549.
- Agama*
adramitana, 914.
batillifera, 915.
flavimaculata, 914.
jayakari, 914.
lehmanni, 914.
lionotus, 914.
microterolepis, 914.
phillipsii, 914.
robecchii, 914.
rueppellii, 914.
smithii, 914.
vallanti, 914.
zonura, 915.
- Agamodon*
anguliceps, 916.
- Agastya*, 599.
- Agathodes*, 598, 730.
caliginosalis, 731.
designalis, 730.
modicalis, 731.
monstralis, 731.
musivalis, 731.
ostentalis, 730, 731.
- Ageronia*
ferentina, 363.
- Aglantha*
digitalis, 1023, 1030,
 1031.
 —, var. *occidentalis*,
 1031.
rosea, 1023, 1030,
 1031.
- Agonus*
cataphractus, 309.
- Agraulis*
vanillæ, 363.
- Agrotera*, 596, 627.
amathealis, 630.
barcealis, 630.
basinotata, 629.
citrina, 629.
cælatalis, 630.
discinotata, 629.
effertalis, 628.
endoxantha, 628,
 761.
fenestralis, 630.
fumosa, 629.
griseola, 629.
ignepicta, 629.
leucostola, 630.
magnificalis, 628.
nemorialis, 630.
pictalis, 630.
retinalis, 630.
scissalis, 628.
setipes, 628.
- Agrotis*
divisa, 383.
- Ailurichthys*
gronovii, 857.
- Akodon*
arenicola, 211.
canescens, 211.
- Alæides*
malagrida, 908.
orthrus, 195.
trikosama, 195.
- Alæna*
amazoula, 907.
nyassæ, 192, 906.
 —, var. *ochracea*, 49,
 54.
picata, 395, 402.
- Alcyonium*
digitatum, 830.
- Alecton*
discoidalis, 320.
- Aletis*
monteironis, 57.
tenuis, 419.
- Alexia*
minor, 338.
- Aloa*
bivittata, 417, 444.
punctistriga, 417.
- Alpheus*
collumianus, 1000,
 1012.
frontalis, 1000, 1001,
 1012.
funafutensis, 1000,
 1013, 1015.
- Alpheus*
gracilipes, 1001, 1013.
lævis, 1000, 1001,
 1012.
lobidens, 1012.
macrochirus, 1001,
 1012.
marmoratus, 1009.
pachychirus, 1001,
 1013.
parvirostris, 1000,
 1012.
prolificus, 1000, 1013.
strenuus, 1000, 1001,
 1012.
- Alytes*
obstetricans, 4-12, 101-
 106.
- Amauris*
albimaculata, 50.
dominicanus, 396.
echeria, 50.
ochlea, 50, 396.
- Amblystoma*
altamirani, 478.
annulatum, 478.
talpoideum, 478.
- Amecera*
maderakal, 369.
- Ameiva*
albuguttata, 916.
bridgesii, 114.
septemlineata, 114.
- Amphibolurus*
imbricatus, 915.
- Amphisbæna*
borellii, 916.
fuliginosa, 114.
liberiensis, 916.
- Amyna*
selenampha, 420.
- Anabita*
lineata, 15.
lurida, 15.
- Analtes*
congenitalis, 663.
tripunctalis, 664.
unipunctalis, 664.
- Analthes*
crinipes, 665.
pyrrhocosma, 665.
- Analyta*, 598, 755.
albicalalis, 755.
calligrammalis, 755.
melanopalis, 755.
pucilla, 755.
sigulalis, 755.
- Anania*
quisqualis, 755.
- Anartia*
dominica, 363.

- Anartia**
iatrophæ, 363.
Anchistia
dancæ, 1004.
spinigera, 1004.
Ancylolomia
chrysographellus, 441.
Ancylometes
vulpes, 29.
Andronymus
philander, 57.
Anguilla
vulgaris, 558, 562,
 565.
Aniculus
typicus, 457, 458,
 461.
Anidrytus
sp. inc., 337.
parallelus, 337.
Anisognatha
quadriplagiata, 220,
 242.
Anisota
stigma, 80.
Anolis
biporcatus, 113.
buckleyi, 110.
chloris, 110, 125, 915.
copii, 111.
cupreus, 114.
curtus, 915, 919, 923.
elegans, 109, 125, 915.
fasciatus, 110.
fusco-auratus, 109.
gemmosus, 111.
gracilipes, 112, 126,
 915.
granuliceps, 111, 126,
 915.
holotropis, 915.
lemniscatus, 113, 125,
 915.
maculiventris, 111,
 126, 915.
notopholis, 915.
peracæ, 108, 125,
 915.
rhomboifer, 114.
rosenbergii, 915.
stigmaticus, 112.
Anomalocera
paterstoni, 541, 543,
 549.
Anomalopterus
pinguis, 556.
Anomalurus
batesi, 450.
Anomis
argillacea, 368.
erosa, 424.
- Anosia**
archippus, 362.
Antheræa
cytherea, 80.
menippe, 80.
nyglitta, 80.
Antheua
cinerea, 433.
simplex, 433.
spurcata, 433.
Anthocharis
antevippe, 410.
exole, 410.
Anthocomus
minimus, 324.
seminulum, 324.
Anthopsyche
gavisa, 410.
Anthropopithecus
gorilla, 989, 994.
troglodytes, 989, 994.
Antigastra, 600.
Antilope
kob, 850.
Aonyx
leptonyx, 186.
Apate
femorialis, 328, 329.
gonagra, 329.
minutus, 330.
substriata, 330.
Apatura
thoe, 364.
Aphnæus
erikssonii, 908.
Aphytoceros
longipalpis, 756.
Apisa
canescens, 417.
Aplectropus, 601.
Aplodes
congruata, 368.
Aplomastyx
minula, 702.
Aporomera
fordii, 916.
Aptenodytes
forsteri, 960, 966, 978,
 983, 985, 986.
patagonica, 966, 985,
 986, 983, 988.
pennanti, 900.
Aquila
chrysaëtos, 280.
Aranea
citricola, 512.
lobata, 512.
Araneus
bettoni, 510, 511, 524.
eresifrons, 509, 510,
 524.
- Araneus**
nauticus, 509, 511, 512.
similis, 509.
striata, 509.
suedicola, 509.
taruensis, 511, 524.
Arbela
albonotata, 438.
Archernis, 693.
Archisometrus
burdoi, 500.
Ardea, 93.
Argadesa
materna, 424.
Argentina
silus, 494, 564.
sphyræna, 564.
Argiolaus
silaris, 407.
silas, 370.
trimeni, 197.
Argiope
ætherea, 513.
argentata, 893.
aurocincta, 512, 524.
caudata, 512.
clathrata, 512.
lobata, 512.
nigrovittata, 512.
suavissima, 512.
Argulus
foliaceus, 543, 544.
Argyris
vestalis, 435.
Argyropeira
ungulata, 513.
Arichalca
sternecki, 441.
Aripana
annulata, 620.
Arnamodia, 600.
Arniocera
auriguttata, 439.
chrysosticta, 439, 444.
cyanozantha, 440.
 —, var., 444.
ericata, 440, 444.
imperialis, 440, 444.
melanopyga, 439.
sternecki, 441, 444.
Arnoglossus
laterna, 284, 285, 557.
Arthroleptis
bottegi, 475.
minutus, 475.
moorii, 475, 479, 482.
whyti, 474.
Arthroseps, gen. nov.,
 916, 920.
wernerii, 916, 921,
 923.

- Arvicanthus**
neumanni, 766.
- Asciodes**
titubalis, 725.
- Aslauga**
marshalli, 908.
purpurascens, 908.
- Asopia**
abruptalis, 442.
archasialis, 702.
biblisalis, 645.
critheisalis, 728.
curtalis, 703.
dircealis, 645.
dototalis, 645.
lydialis, 699.
microchrysalis, 695.
misera, 698.
phærusalis, 703.
sernalis, 693.
socialis, 639.
suffectalis, 645.
- Aspidosiphon**
elegans, 471, 473.
klunzingeri, 471, 473.
- Aspidosoma**
ignitum, 318, 319.
lepidum, 318.
polyzona, 318.
superciliolum, 318.
- Astacus**
penicillatus, 1014.
- Astræopora**
listeri, 264, 265.
ovalis, 265.
punctifera, 265.
tabulata, 264, 276.
- Astura**
erscalis, 690.
guttatalis, 690.
semifascialis, 690.
- Astylus**
antillarum, 323, 333.
octopustulatus, 323.
- Asymbata**
roseiventris, 424.
- Atalapha**
cinerea, 77.
- Atechna**
interruptofasciata, 241,
 242.
pardalina, 242.
- Atelecyclus**
heterodon, 204, 205, 207,
 208, 209.
septemdentatus, 207.
- Atella**
columbina, 53, 399,
 822.
phalantha, 53.
- Atelocentra**, 599.
- Atelopus**
cruciger, 119.
elegans, 119.
ignescens, 119.
- Aterica**
galene, 52.
- Atethmia**
subusta, 368.
- Athanas**
dimorphus, 1012.
subcatipes, 1000, 1011,
 1015.
- Athanasus**
edwardsii, 1012.
- Atherura**
africana, 887.
fasciculata, 887.
- Atractus**, 539, 540.
badius, 116.
multicinctus, 116.
- Attacus**
atlas, 80.
cynthia, 80.
mythimna, 80.
pernyi, 80.
ricini, 80.
- Attus**
pictilis, 488.
- Atya**
wycki, 1003.
- Aulacantha**
lævissima, 1022, 1026,
 1032.
- Aulacoptera**, 595, 617.
fuscinervalis, 617.
- Auloceros**
trigeminus, 1022,
 1026.
 (Aulocera) *trigeminus*,
 1027.
- Aulocoryne**
zetesios, 1023, 1027,
 1032.
- Aulographis**
 sp., 1022.
moorensis, 1022, 1026,
 1032.
 (Aulagraphonium)
moorensis, 1026.
- Aulosphæra**
flexuosa, 1023, 1026.
- Authæretis**, 596, 711.
eridora, 711.
- Autocosmia**, 602.
- Autodax**
iecanus, 478.
- Auxomitia**
minoralis, 640.
mirificalis, 672.
- Avicula**
formosa, 828.
- Avicularia**
avicularia, 892.
- Axiocerces**
perion, 370.
- Azanus**
jesous, 194, 404, 826.
moriqua, 194.
natalensis, 193.
plinius, 194.
zena, 194.
- Azochis**, 601.
- Azygophleps**
inclusa, 382.
- Bacteria**
mexicana, 942.
- Balæniceps**, 83.
- Baniana**
intorta, 383, 423.
- Baoris**
auritinctus, 416,
 444.
ayresii, 200.
cojo, 57.
fatuellus, 416.
netopha, 57.
roncilgonis, 57.
- Baracus**
inornatus, 201.
- Basiliscus**
galeritus, 114.
- Bassariscus**
astutus, 129, 130.
- Bathybates**, gen. nov.,
 495.
ferox, 495.
- Bathytroctes**
melanocephalus, 556.
- Bdellophis**
vittatus, 479.
- Belenogaster**
saussurei, 386.
- Belenois**
abyssinica, 380.
anomala, 380.
creona, 380, 412.
girdica, 380, 412.
infida, 56.
liliana, 413.
mesentina, 380, 822.
 —, var. *lordaca*, 56,
 412.
severina, 56, 911.
thysa, 56, 412.
zochalia, 56.
- Benthoosema**
mülleri, 553.
- Betæus**
minutus, 1014.
- Bettonia**, gen. nov., 418.
ferruginea, 418, 444.

- Birgus**
hirsutus, 459.
laticauda, 458.
latro, 457, 458.
- Bithynis**
lar, 1008.
- Biton**
brunnipes, 523.
fuscipes, 523.
tigrinum, 522, 524.
- Blanus**
aporus, 916.
- Blatta**
americana, 243, 244.
orientalis, 242.
- Blepharomastix**
datialis, 702.
pulverulalis, 702.
romalis, 616.
sagralis, 703.
- Blosyris**
vates, 368.
- Boarmia**
acaciaria, 383.
oppositaria, 368.
- Bocchoris**
acamasalis, 651.
actealis, 653.
adalis, 650.
adipalis, 652.
aptalis, 653.
argyralis, 653.
artificialis, 653.
aurotinctalis, 653.
cæcalis, 653.
chalcidiscalis, 652.
ciliata, 654.
clathralis, 652.
clytialis, 654.
contortilinealis, 651.
dunalis, 651.
darsanalis, 651.
euphranoralis, 652.
flavibrunnea, 651, 761.
fracturalis, 653.
inductalis, 650.
inscisalis, 651.
insipidalis, 652.
inspersalis, 654.
invertalis, 650.
junctifascialis, 650,
 761.
marucalis, 651.
minima, 652.
onychinalis, 650, 651.
pulverealis, 652.
quaternalis, 654.
rotundalis, 650.
sphenocosma, 652.
stigmatalis, 652.
talis, 654.
- Bocchoris**
telphusalis, 651.
terealis, 651.
trimaculalis, 654.
trivitalis, 651.
xanthialis, 653.
- Bœotarcha**, 599.
- Bombinator**, 5.
- Bomolocha**
exoletalis, 368.
- Berberocœtes**
mexicanus, 477, 481,
 482.
- Bos**
sondaicus, 277.
 — *birmanicus*, 277.
- Bostrichus**
longicornis, 329.
- Botis**
defloralis, 625.
- Botyodes**, 505, 709.
asialis, 709, 710.
aurealis, 710.
caldusalis, 710.
crocopteralis, 710.
flavibasalis, 710.
fraterna, 720.
fulviterminalis, 710.
hirtusalis, 710.
leopardalis, 723.
maculalis, 710.
patulalis, 710.
principalis, 710.
rufalis, 710.
- Botys**
acastalis, 727.
accipitralis, 719.
acerrimalis, 638.
agavealis, 658.
agenoralis, 678.
allalis, 704.
alvinalis, 658.
amplalis, 722.
amplipennis, 678.
amyntusalis, 442.
annuligeralis, 722.
anticostalis, 657.
arbiter, 635.
asiusalis, 616.
atyriialis, 685.
aurea, 719.
aureolalis, 689.
azionalis, 639.
basipunctalis, 722.
belusalis, 703.
bianoralis, 698.
bornealis, 637.
boteratis, 722.
campalis, 655.
candacalis, 716.
chalybealis, 706.
- Botys**
codrusalis, 697.
coidalis, 644.
conjunctalis, 659.
connexalis, 699.
convectalis, 639.
cosisalis, 715.
creonalis, 639.
crocealis, 719.
cubanalisis, 655.
cydipeialis, 708.
cypræalis, 720.
dascyllusalis, 702.
decisalis, 698.
delicatalis, 648.
demeter, 691.
differalis, 696.
disjunctalis, 661, 720.
dracusalis, 713.
electralis, 702.
epastalis, 698.
eurytalisis, 678.
fasciculatalis, 638.
faustalis, 728.
flexissimalis, 651.
fulginalis, 658.
galbula, 649.
gastralis, 666.
gealis, 706.
germanalis, 685.
glaucusalis, 657.
gnomalis, 684.
gracialis, 702.
haliusalis, 922.
halmusalis, 698.
heronalis, 727.
hortalis, 755.
hyalinalis, 738.
hypsidésalis, 694.
illatalis, 646.
ilusalis, 702.
imbutalis, 721.
impeditalis, 642.
inanitalis, 725.
incalis, 700.
ineffectalis, 702.
infundibulalis, 622,
 693.
intactalis, 739.
invenustalis, 637.
iolealis, 638.
jasonalis, 685.
judundalis, 645.
korndorfferi, 698.
levalis, 666.
luciferalis, 747.
margaronialis, 668.
marisalis, 638.
medonalis, 759.
megaloopsalis, 640.
melitealis, 702.

Botys

memialis, 655.
minoralis, 698.
minutalis, 706.
moliusalis, 699.
molliculalis, 721.
molucalis, 641.
molusalis, 703.
monesusalis, 733.
mysolalis, 719.
neoclesalis, 639.
nicippealis, 690.
nigrodentalis, 725.
notatalis, 652.
nursicalis, 638.
oajacalis, 679.
odiusalis, 723.
œmealis, 715.
œnippealis, 697.
ofellusalis, 702.
ogmiusalis, 666.
ollaris, 644.
olliusalis, 702.
onusalis, 689.
orobenal, 723.
orontesalis, 685.
orphnealis, 713.
otysalis, 722.
paleacalis, 725.
palmalis, 720.
palpalis, 663.
partialis, 740.
paucilinealis, 725.
peleusalis, 684.
pelialis, 679.
peranthusalis, 666.
perpendicularis, 725.
phanasalis, 733.
phryganurus, 747.
plagiatalis, 722.
plagiferalis, 728.
præteritalis, 698.
principalis, 728.
propinqualis, 729.
proximalis, 630.
pruinialis, 658.
psychicalis, 608.
pyrenealis, 759.
quadriguttalis, 719.
quadrimalculalis, 724.
quinquepunctalis, 739.
quirinalis, 723.
reductalis, 699.
restrictalis, 720.
retractalis, 684.
rogatalis, 760.
rubricetalis, 704.
ruptalis, 639.
ruralis, 638.
ruricolalis, 725.
rutilalis, 628.

Botys

sabalis, 699.
sanguiflualis, 720.
saturalis, 937.
sectalis, 678.
selectalis, 642.
semifascialis, 689.
semizebralis, 728.
serratilinealis, 657.
sinonalis, 729.
sordidalis, 692.
strictalis, 702.
subæqualis, 713.
subjunctalis, 689,
 714.
sublittoralis, 721.
submarginalis, 739.
superbalis, 700.
suspicalis, 639.
tardalis, 722, 725.
temeratalis, 728.
thalassinialis, 734.
thisoalis, 723.
thoasalis, 657.
thyasalis, 714.
tisiasalis, 708.
triferalis, 689.
trigalis, 728.
turnusalis, 648.
tytiusalis, 643.
urticaloides, 758.
ustalis, 699.
ventralis, 653.
vitalis, 644.

Boulengerula
boulengeri, 479.

Brachythele
antillensis, 892, 899.

Brihaspa
chrysostomus, 441.

Brissus
unicolor, 850.

Bubalis
boselaphus, 352.
lichtensteini, 393.
major, 350.
swaynei, 767.

Bubalus
planiceros, 349.

Bufo
coccifer, 478.
coniferus, 123, 478.
dodsoni, 477.
dombensis, 477.
glaberrimus, 123.
hæmatiticus, 123.
marinus, 123.
penangensis, 477.
steindachneri, 477.
taitanus, 477.
typhonius, 123.

Bulweria, 90.

Bunæa
barcas, 429.
 (Thyella) *zambesia*,
 429.

Bunæa
phædusa, 80, 81.

Buthus
eminii, 499.

Byblia
acheloia, 53, 376, 377.
anvatara, 375, 377.
boydi, 375, 376, 377,
 378, 379, 391.
castanea, 377.
gotzius, 375, 376, 377,
 378, 379.
ilithyia, 370, 375, 376,
 377, 378, 400, 822.
vulgaris, 53, 377.

Cacyreus

lingeus, 54, 907.

Cæcilia

isthmica, 125.

Cærostris

mitralis, 515, 516.
nodulosa, 514, 524.
rugosa, 516.
sexcuspidata, 515.
simata, 516.

Calamochrous, 599.

Calanus

cristatus, 546.
finmarchicus, 540, 541,
 542, 544, 545, 546,
 549, 578, 579.
hyperboreus, 541, 544,
 547.
propinquus, 545.

Calasposoma

bonvouloiri, 235.
marshalli, 233.
melancholicum, 235.
plumbeum, 233.
pubescens, 235.
pubipenne, 234.

Calceinus

elegans, 457, 458, 461,
 462.
gaimardi, 458, 492.
herbsti, 457, 458, 462.
 —, var. *lividus*, 457,
 458, 462.
latens, 457, 458, 463.
tibicen, 462.

Calisto

hysius, 362.

Callianidea

typa, 1000, 1001, 1015.

- Callichthys**
asper, 492.
littoralis, 492.
- Callidryas**
buquetii, 413.
sennæ, 365.
thalestris, 365.
- Callilepis**
nocturna, 488.
- Callionymus**
dracunculus, 284.
longicaudatus, 286.
lyra, 281, 284, 286,
 315.
reevesii, 286.
- Calliostoma**
similaris, 828.
- Callosune**
hetæra, 408.
- Caloctenus**
guineensis, 15.
- Calophasia**
upsilon, 420.
- Calophrynus**
brevis, 476.
calcaratus, 479.
- Calopteron**
albicolle, 317.
amabile, 317.
aulicum, 317.
bicolor, 317.
delicatum, 316.
denominatum, 317.
distinguendum, 317.
dominicanum, 317.
elegantulum, 317.
nigritarse, 317.
oblitum, 316.
pectinicornis, 317.
smithi, 315, 333.
suave, 317.
- Calpe**
emarginata, 383.
- Calpodes**
ares, 367.
- Calyptorhynchus**
banksi, 355.
macrorhynchus, 355,
 356.
stellatus, 355, 356.
- Calysisme**
anymana, 374, 375,
 379.
socotrana, 374.
- Cambarus**
pellucidus, 957.
- Camptolenes**
abyssinica, 222.
- Cancer**
clypeatus, 459.
irroratus, 205, 206.
- Cancer**
latro, 458.
pagurus, 204, 205, 207,
 208, 209.
scyllarus, 36.
tibicen, 462.
- Cancroma**, 85.
- Candace**
truncata, 543, 549.
- Canis**
aureus, 154, 156, 157,
 158, 159, 160, 163,
 164, 165, 167, 168,
 169, 171, 172, 173.
dingo, 154.
familiaris, 154, 156,
 159, 160, 163, 164,
 165, 167, 168, 169,
 171, 172, 175.
lagopus, 154, 157, 159,
 160, 165, 169, 171,
 172, 173.
lupus, 172.
mesomelas, 154, 156,
 157, 159, 160, 163,
 164, 165, 167, 168,
 169, 171, 172, 173,
 764.
vulpes, 73, 154, 172,
 186.
- Capnodes**
rufinans, 368.
- Caprinia**, 597, 667.
- cirrhalis*, 668.
conchylalis, 668.
conglobatalis, 668.
diaphanalis, 668.
felderi, 668.
hypheusalis, 668.
intermedia, 668.
periusalis, 668.
- Caprona**
canopus, 199.
- Caradina**
vitiensis, 1001, 1003,
 1015.
weberi, 1003.
wycki, 1001, 1003.
- Caretochelys**
insculpta, 851.
- Caryophyllia**
clavus, 995.
- Castalius**
calice, 907.
hintza, 194.
melæna, var., 404.
- Cataclysta**
fraterna, 637.
- Catapsephis**, gen. nov.,
 594, 612.
apicipuncta, 612.
- Catarrhactes**
catarrhactes, 981.
chrysome, 959, 960,
 961, 963, 965, 967,
 969, 971, 975, 980,
 981, 983, 985, 986,
 988, 989.
chrysolophus, 959, 960,
 961, 963, 965, 977,
 978, 983, 984, 985,
 986.
pachyrhynchus, 981,
 983, 985, 986.
schlegeli, 959, 960, 963,
 964, 981.
sclateri, 981.
- Cathorama**
herbarium, 325, 327.
- Catochrysops**
ariadne, 193, 201.
asopus, 192.
barkeri, 192.
dolorosa, 193.
gigantea, 907.
glauca, 193.
hypoleucus, 403, 907.
hippocrates, 404.
ignota, 193.
mahallokoæna, 193,
 907.
niobe, 187, 193.
osiris, 54, 403, 826.
patricia, 54, 192.
perpulchra, 403.
prebeia, 192, 201.
- Catopsilia**
florella, 55, 198, 371,
 381, 412, 824, 911.
pyrene, 381.
- Cavia**
australis, 211.
boliviensis, 211.
- Centriscus**
niloticus, 816.
- Centropages**
typicus, 541, 543.
- Cephalophus**
æquatorialis, 393, 394.
coronatus, 350.
hecki, 393.
lugens, 393, 394.
maxwelli, 350.
melanorheus, 393,
 394.
monticola, 393, 394.
rufilatus, 350.
- Ceracis**
bifurcus, 332, 333.
furcifer, 331, 332.
militaris, 331.
tricornis, 332.

- Ceracis
unicornis, 332.
- Ceramodactylus
damæus, 912.
pulcher, 912.
- Ceratarcha, 595, 709.
umbrosa, 709.
- Ceratium
furca, 1029.
tripos, 1029.
 — *baltica*, 1029.
 — *horrida*, 1029.
 — *macroceros*, 1029.
 — *longipes*, 1029.
 — *scotica*, 1029.
 — *tergestina*, 1029.
- Ceratoclasia
metallica, 660.
rooalis, 660.
tenebralis, 660.
verecundalis, 655, 713.
- Ceratodus
forsteri, 492, 586.
- Ceratomia
amytor, 80.
undulosa, 80.
- Ceratophrys
crisiceps, 477.
- Ceratrichia
stellata, 416.
- Cercoleptes
caudivolvulus, 154,
 184.
- Cercopithecus
alboocularis, 586.
l'hoesti, 586.
- Ceriagrion
glabrum, 386.
- Cerocala
vermiculosa, 383.
- Ceroma
johnstoni, 523, 524.
ornatum, 524.
variatum, 523, 524.
- Cervicapra
redunca, 350.
- Cervus
barbarus, 280.
dauidianus, 281.
xanthopygius, 588.
 (Elaphurus) *dauidianus*, 588.
- Cetengraulis
juruaensis, 44.
- Chabula
reniferalis, 651.
vedrualis, 652.
- Chæstostomus
hachi, 44.
- Chalcides
mauritanicus, 918.
- Chalcidoptera, 597, 664.
ædilis, 665.
appensalis, 665.
atriobalis, 664.
bilunalis, 665.
emissalis, 664, 665.
pryeri, 665, 761.
rubra, 665.
rufilinealis, 665.
straminialis, 664.
- Chamæleon
elliotti, 918.
fischeri, 918.
hoehnelii, 918.
jacksonii, 918.
spinusus, 918.
- Chamæsauro
tenuior, 915.
- Chapra
mathias, 912.
- Charaxes
azota, var. *nyasana*,
 823.
balfourii, 373.
bohemani, 824.
brutus, 822, 823.
candiope, 824.
castor, var. *flavifasciatus*,
 823.
cithæron, 397, 824.
guderiana, 823.
hansalii, 370.
lactetinctus, 823.
laticinctus, 904.
macclounii, 824.
neanthes, 397.
pollux, 823.
saturnus, 188, 904.
varanes, 51, 397, 824.
zoolina, 397.
- Charema
albociliata, 684.
carbonalis, 686.
fuscipennis, 698.
- Cheiridisia, gen. nov.,
 226.
inornata, 226, 242.
- Cheiromeles
torquatus, 59.
- Chilena
donaldsoni, 436.
prompta, 436.
- Chiridota
australiana, 846.
contorta, 846.
dunedinensis, 846.
intermedia, 835, 846,
 848.
lævis, 846.
liberata, 835, 845, 846,
 847.
- Chiridota
pisanii, 846.
rotifera, 846.
- Chiroleptes
dahlæi, 477.
- Chiromantis
xerampelina, 475.
- Chloëon
 (Ephemera) *dimidiatum*, 956.
- Chondrostoma
nasus, 282.
- Chromidotilapia, gen.
 nov., 151.
frederici, 151.
kingsleyæ, 151, 152.
- Chromis
castanea, 132.
diagramma, 496.
frederici, 151.
livingstonii, 146.
moftati, 140.
ngamensis, 146.
thumbergi, 146.
- Chromodes
armeniacalis, 728.
- Chrysomela
africana, 241.
clavicornis, 336.
natalensis, 240.
- Chrysophanus
orus, 195.
- Ciconia, 93.
- Cidaris
metularia, 849.
- Ciuosternum
leucostomum, 108.
- Cirrocephala
venosa, 682.
- Cis
fuscatus, 331.
nubilus, 331.
pusillus, 330.
- Clarias
liocephalus, 496.
- Clibanarius
æquabilis, 457, 463.
corallinus, 457, 463.
globosimanus, 463.
obesomanus, 463.
zebra, 457, 463.
- Cliniodes, 598, 748.
cyllarusalis, 748.
euphrosinalis, 749.
opalalis, 748, 749.
paradisalis, 749.
paucilinealis, 749.
rutilalis, 749.
saburralis, 749.
semilunalis, 749.
subcostalis, 748.

- Clæosiphon
aspergillum, 471, 473.
 Cnaphalocrocis, 596,
 637.
bifurcalis, 639.
medinalis, 638.
perpersalis, 640.
sanitalis, 639.
similis, 640.
 Cnemidophorus
hyperythrus, 916.
immutabilis, 916.
leachii, 916.
 Cobus
kob, 350.
maria, 352.
unctuosus, 281, 350.
 Coccinella
connectens, 340.
maculata, 339.
sanguinea, 339.
surinamensis, 336.
thoracica, 341.
 Cœlodendrum
ramosissimum, 1023,
 1027.
 Cœlogenys
paca, 867.
 Cœloplegina
murrayanum, 1023,
 1026.
 — *tritonis*, 1027.
 Cœnina
aurivena, 433.
flavivena, 433.
pæcularia, 433.
 Cœnobia
brunnea, 459.
cavipes, 460.
clypeatus, 459.
olivieri, 459.
perlatus, 457, 458,
 459.
purpurea, 459.
rugosus, 457, 458, 460.
 —, var. *pulcher*, 457,
 458, 460.
spinus, 458, 459.
 Cœnostola
eruptalis, 685.
 Colænis
delila, 363.
 Colasposoma
semihirsutum, 232, 233.
thoracicum, 235.
vestita, 235.
villosum, 235.
 Colbusa
pentagonalis, 423.
 Colias
electra, 370, 822.
 Colias
hyale, var. *electra*, 197.
marinoana, 822.
sareptensis, 822.
 Collozoum
 sp., 1022, 1024.
ellipsoides, 1024.
inermis, 1024.
 Colobus
guereza, 587.
 Colostethus
latinus, 119, 476.
 Comibæna
leucospilata, 58.
 Conchedytes
meleagrinae, 1001,
 1007.
 Conchœcia
maxima, 578.
 Conchylia
smithi, 417.
 Conchylodes, 598, 674.
argentalis, 675.
baptalis, 620.
bryophilalis, 674, 761.
concinna, 675.
corycicalis, 620.
diphtheralis, 674.
hebræalis, 674.
hedonialis, 675.
nolkenialis, 675.
ovulalis, 675.
paucipunctalis, 620.
platinialis, 675.
salamisalis, 674.
striginalis, 675.
zebra, 675.
 Condylorrhiza, 600.
sublulalis, 720.
 Conger
vulgaris, 565.
 Connochætes
gnu, 586.
 Conogethes
lictor, 685.
nubifera, 693.
semistrigalis, 689.
umbrosa, 693.
 Coptobasis
ænealis, 714.
andamanalis, 715.
hiocellata, 713.
colomboensis, 723.
incrassata, 714.
leonatis, 725.
luminalis, 714.
möllingeri, 725.
spretalis, 725.
 Co alliocaris
brevirostris, 1000, 1006,
 1007, 1015.
 Coralliocaris
macrophthalma, 1007.
 Corematodus
shiranus, 152.
 Coris
giofredi, 284.
greenoughi, 1002.
julis, 284.
 Cornifrons, 602.
 Cornufer
baluensis, 474.
 Corystes
cassivelaunus, 208,
 209.
 Corythomantis
greeningi, 478.
 Coscinaræa, 533.
mæandrina, 535.
monile, 535.
 Cosmophila
erosa, 424.
 Cosmosoma
auge, 367.
 Cottus
bubalis, 308.
 Crambus
chrysographellus, 441.
 Craspedia
derasata, 383.
lactaria, 383.
pulverosaria, 383.
 Cratomorphus
dorsalis, 320.
 Crax
pinima, 348.
sclateri, 348.
 Crenicichla
saxatilis, 492.
 Crenidomimas
concordia, 52.
crawshayi, 52.
 Crenis
boisduvali, 52, 53.
 Crioceris
elongata, 215.
 Criophthona, 602.
 Crocidolomia, 599, 758.
binotalis, 759.
luteolalis, 759.
palindialis, 759.
suffusalis, 758.
 Crocidophora, 601.
 Crocidura
 sp. inc., 771.
leucura, 762.
murina, 762.
russula, 771.
 Crocothemis
erythræa, 386.
 Cropera
testacea, 427.

- Crossarchus
 fasciatus, 392.
 somalicus, 763.
- Crudaria
 leroma, 54, 195.
- Cryptocephalus
 africanus, 223, 225.
 angustofasciatus, 225.
 atrocinctus, 223.
 bimaculicollis, 225.
 epipleuralis, 223, 242.
 nigrofrontalis, 223.
 sulcifrons, 224.
 unicinctus, 225.
- Cryptognatha
 melanura, 341, 343.
- Cryptographis
 rogenhoferi, 739.
- Cryptoprocta
 ferox, 153, 183, 185.
- Ctenomys
 magellanicus, 211.
- Ctenus
 aculeatus, 15, 18.
 albo-fasciatus, 19.
 andrewsi, 19.
 boliviensis, 19.
 burtoni, 13, 20, 25, 32.
 carsoni, 13, 20, 21, 22,
 24, 26, 32, 518.
 corniger, 13, 20, 26, 32.
 fimbriatus, 14, 15, 28.
 johnstoni, 13, 17, 20,
 21, 25, 32.
 kingsleyi, 13, 19, 20,
 21, 22, 23, 24, 32.
 lycosinus, 14, 18.
 marginatus, 28.
 marshalli, 13, 20, 26,
 32.
 modestus, 14, 18.
 occidentalis, 13, 20, 21,
 23, 24, 32.
 pallidus, 14, 17, 18, 29.
 pulchriventris, 14, 18.
 reidyi, 19.
 spenceri, 13, 19, 20, 23,
 32.
 spinosissimus, 14, 17,
 28, 29.
 syriacus, 14, 17, 29.
 torvus, 14, 18, 29.
 vagus, 14, 16, 20.
 velox, 14, 15, 18, 20, 32.
 vividus, 14, 16, 18, 19,
 20.
- Cnemaria
 africana, 843.
 assimilis, 843.
- Culcita
 grax, 849.
- Cupidopsis
 jobates, 193, 404.
- Cupiennius, 27.
- Cybolomia, 600.
- Cyclarcha
 atristrigalis, 623.
 flavinervis, 623.
 pallidicostalis, 623.
- Cyclocena
 gestatalis, 727.
- Cycloneda
 delauneyi, 340.
 pallidula, 340.
 rubida, 340.
 sanguinea, 339.
- Cyclopides
 carsoni, 57.
 metis, 200.
 perexcellens, 57.
- Cyclosa
 formosa, 513.
- Cydalima
 elwesialis, 732.
- Cygnus
 nigricollis, 456.
- Cylogramma
 fluctuosa, 421.
 latona, 421.
 limacina, 422.
 rudilinea, 422.
- Cynæda, 600.
- Cynælurus
 jubatus, 153, 158, 182.
- Cynanisa
 isis, 80.
- Cynictis
 penicillata, 153, 159.
- Cynocephalus
 hamadryas, 351.
- Cynonycteris
 amplexicaudata, 59.
 collaris, 61.
- Cynopteris
 brachyotis, 76.
- Cypra
 crocipes, 427.
- Cyrtauenius
 flaviceps, 506.
 terricola, 507.
 zebra, 507.
- Cyrtodactylus
 affinis, 455.
- Cyrtophora
 citricola, 512.
- Cystineura
 teleboas, 363.
- Cythere
 scabrocuneata, 204.
- Damaliscus
 korrigum, 350.
- Damia
 mashonana, 217.
- Danaga
 biformis, 695.
- Daptonura
 salacia, 365.
- Daulis
 sanguinea, 339.
- Dausara, 600.
- Deba, 595, 708.
 althealis, 708.
 milvinalis, 657.
 surrectalis, 708.
- Deilephila
 elpenor, 80.
 euphorbiæ, 80.
 galii, 80.
 porcellus, 80.
- Deiopeia
 pulchella, 57, 371, 382,
 383.
 speciosa, 367.
- Dendrobates
 tinctorius, 119.
- Desmia, 596, 630.
 bajulalis, 632.
 bulisalis, 631.
 ceresalis, 631.
 chryseis, 633, 761.
 confusalis, 713.
 discrepans, 632.
 divisalis, 631.
 extrema, 632.
 funeralis, 632.
 funeralis, 630, 631.
 geminalis, 631.
 intermicalis, 631.
 jovealis, 633.
 maculalis, 631.
 melaleucalis, 632,
 761.
 naclialis, 633.
 notalis, 632.
 odontoplasma, 633.
 paucimaculalis, 632.
 pentodontalis, 631.
 pisusalis, 632.
 ploralis, 632.
 prognealis, 631.
 propinqualis, 631.
 rhinthonalis, 623.
 sepulchralis, 632.
 strigivitratis, 632.
 subdivisalis, 631.
 tages, 631.
 ufeus, 368, 631.
 viduatalis, 633.
- Desmodus, 76, 78.
 rufus, 76.
- Desmognathus
 brimleyorum, 479.

- Deudorix**
dariaves, 406.
diocles, 406.
livia, 370.
- Dialexia**
punctipennis, 338.
- Diaphania**
vitralis, 737.
- Diasemia**, 600.
- Dichocrocis**, 597, 688.
actinialis, 690.
auritincta, 693.
bilinealis, 690.
bistrigalis, 690.
cernatis, 688.
clioalis, 688, 690.
credulalis, 693.
definita, 691.
diminutiva, 691.
eubulealis, 693.
evaxalis, 689.
festivalis, 688, 691.
fluminalis, 689.
frenatalis, 690.
fuscifimbria, 690.
fuscoabalis, 692.
hæmactalis, 691.
megillalis, 692.
nigrilinealis, 691.
paotolica, 692.
pandamalis, 690.
plenistigmalis, 692.
pluto, 690.
plutusalis, 691.
pseudpæonialis, 688.
punctiferalis, 688, 690.
punctilinealis, 691.
pyrrhalis, 692.
recurrens, 692.
renidata, 692.
rigidalis, 692.
sabatialis, 690.
spoliatalis, 688, 693.
strigimarginalis, 693.
surusalis, 689.
tharsalea, 691.
tripunctapex, 691, 761.
xanthocyma, 689.
xuthusalis, 689.
zebralis, 692.
- Dichogama**, 597, 676.
amabilis, 677.
bergii, 677.
decoralis, 676.
fernaldi, 677.
gudmanni, 677.
innocua, 676.
krugii, 676.
redenbacheri, 676, 677.
smithi, 677.
- Dichogaster**
parvus, 445, 449.
- Dictyochoa**
 sp., 1029.
fibula, 1029.
rhombus, 1029.
speculum, 1029.
stapedia, 1029.
- Dictyocysta**
elegans, 1029.
- Dicymolomia**
pegasalis, 369.
- Dilophonota**
ello, 367.
- Dinoderus**
bifoveatus, 330.
minutus, 330.
substriatus, 330.
- Diodosida**
roseipennis, 432.
- Diogenes**
pallescens, 457, 463.
- Diphylla**, 76.
- Diplodactylus**
hyrnei, 913.
conspicillatus, 913.
gracilis, 913.
intermedius, 913.
porogaster, 913.
robustus, 913.
- Diploglossus**
nuchalis, 916, 920, 923.
- Diporophora**
winneckii, 915.
- Dipsas**
antalus, 407.
- Dipus**
hirtipes, 858, 882.
jaculus, 766, 858, 859, 882.
- Discoglossus**, 4, 5.
- Discosoma**
haddoni, 1002.
- Discothyris**, 601.
- Dismorphia**
spio, 364.
- Distira**
stokesii, 851.
- Dolichosticha**
perinephes, 639.
subauralis, 639.
subvenialis, 640.
- Doliolum**
denticulatum, 580.
nationalis, 567, 583.
tritonis, 567, 580, 581, 583.
 (Dolioletta) *tritonis*, 580.
- Dolomedes**, 27.
imbriatus, 27.
- Dolomedes**
spathularis, 29.
- Dolopæus**, 27.
albocinctus, 28.
cinctus, 28, 29, 32.
doleschallii, 28.
simoni, 28.
- Draco**
beccarii, 914.
obscurus, 914.
- Drassus**
cupreus, 488.
lapidicolens, 488.
trogloodytes, 488.
- Dryas**
leda, 413.
- Drymobius**
boddaertii, 115.
dendrophis, 115.
rhombifer, 115.
- Drymceca**
hæsitata, 378.
- Durbania**
freya, 403.
hildegarda, 402, 403.
- Dyscophus**
grandidieri, 476.
- Dysgonia**
abnegans, 422.
 —, var., 422.
angularis, 422.
conjunctura, 422.
neptunia, 422.
palpalis, 422.
- Eacles**
imperialis, 80.
- Eagris**
gimesoni, 199.
- Eantis**
papinianus, 367.
- Ebæus**
minimus, 323, 324.
nigrocæruleus, 323, 324.
seminulum, 323, 324.
- Ebula**
zelleri, 715.
- Echinometra**
lucunter, 850.
oblonga, 850.
- Echinoneus**
cylostomus, 850.
- Echinosaura**
horrida, 114.
- Echinothrix**
diadema, 849.
- Eclipsiodes**
marmaropa, 704.
- Ecpantheria**
decora, 367.

- Ectinosoma**
atlanticum, 541, 543.
Ectodus, gen. nov., 497.
descampsi, 497.
melanogenys, 497.
Egernia
*dahl*i, 916.
Egnasia
vicaria, 425.
Egybolia
vaillantina, 58, 429.
Elaps
ancoralis, 117.
corallinus, 117.
rosenbergi, 117, 126.
Eligmodontia
bimaculata, 211.
elegans, 210, 211.
gracilipes, 211.
griseoflava, 210.
moreni, 211.
Empyreuma
lichas, 367.
Enchoenemidia
fuscitibia, 735.
Endographis, 595, 725.
acrochlora, 726.
Endolophia, 599.
Endotricha
annuligera, 695.
Engystoma
borneense, 476.
Ennearthron
affine, 331.
Entephria, 595, 618.
abraxalis, 619.
alboflavalis, 619.
argenticincta, 620.
cribrata, 619.
crocalis, 621.
deiconalis, 619.
diaphana, 619.
divaricata, 621.
excurvalis, 665.
glaucias, 620.
idalis, 620.
jaguaralis, 619.
lactiferalis, 620.
levinia, 620.
macrotis, 620.
marginalis, 620.
meritalis, 620.
ariferalis, 620.
pantheiata, 620.
præruptalis, 621.
radiata, 620.
receptalis, 619.
sytleptalis, 621.
virgatalis, 619.
Entomogramma
nigriceps, 424.
- Enyalioides**
festæ, 114, 915.
heterolepis, 915.
Epeira
albida, 510.
ceropegia, 488.
diademata, 488.
locuples, 510.
madagascariensis, 508.
nautica, 509.
pilipes, 509.
quadrata, 488.
similis, 509.
suedicola, 509.
Epiblemum
scenicum, 488.
Epicorsia
iridialis, 721.
Epimima
stereogona, 639.
Epipagis
corrivalis, 642.
Epomophorus, 58.
comptus, 78.
minor, 77.
Equus
boehmi, 3.
burchelli boehmi, 3.
— *crawshayi*, 393.
— *granti*, 3.
— *selousi*, 3.
grevii, 588.
zebra, 456.
Ercta, 596, 636.
chalybites, 637.
dixialis, 704.
elutalis, 637.
hemialis, 637.
ornatalis, 637.
tipulalis, 637.
vittata, 637.
Eremias
smithii, 916.
striata, 916.
Eretis
djelæla, 57.
Eretmodus, gen. nov.,
495.
cyanostictus, 496.
Ericeia
inangulata, 421.
Erigone
dentipalpis, 488.
Erilusa
dianalis, 725.
dioploides, 717.
mimalis, 725.
nitealis, 725.
pseudauxo, 717, 725.
radialis, 717.
secta, 725.
- Erinothus**, gen. nov., 595
706.
lollialis, 706, 707.
Eronia
dilatata, 413, 826, 827.
leda, 413.
Erpis, 594, 614.
macularis, 614, 615.
Erythrinus
uniteniatus, 492.
Erythrolamprus
æsculapii, 117.
Esox
lucius, 314.
Eteta
sexfasciata, 751.
Eucalanus
attenuatus, 541, 542,
546, 547, 549.
Euchæta
barbata, 542, 548.
gigas, 543, 548.
hessii, 543, 548, 549.
marina, 543, 548, 549.
norvegica, 541, 543,
546, 547, 549, 579, 580.
prestandrea, 548.
Euchætes
insulata, 367.
Euchirella
pulehra, 541, 542, 548.
rostrata, 548.
Euchloe
falloni, 371.
Euchromia
africana, 417.
amana, 417.
Euclasta, 598, 751.
defamatalis, 751, 752.
fligerialis, 752.
maceratalis, 751.
splendidalis, 751.
torquittalis, 752.
warreni, 752.
Eucratoscelus, gen. nov.,
500.
longiceps, 500.
Eudæmonia
brachyura, 80.
Eudamus
dorantes, 366.
proteus, 366.
simplicius, 366.
Eudioptis
capensis, 738.
damalis, 747.
perspicillalis, 742.
Eudynamis, 48, 49.
Eudyptula
albosignata, 960, 963,
983, 985, 986, 988.

- Eudypstula**
minor, 960, 963, 978,
 983, 985, 986.
- Eumeces**
blythianus, 918.
- Eupagurus**
bernhardus, 311.
setifer, 461.
- Euphædra**
neophron, 52.
violacea, 399.
- Euplexia**
conducta, 383.
opposita, 420.
- Euplæa**
ochlea, 393.
- Eupoca**
cinerea, 609.
- Euprepes**
insignis, 729.
- Euralia**
anthon, 51.
deceptor, 51.
dinarcha, 51.
kirbyi, 51, 399.
mechowi, 51.
usambara, 51.
wahlbergi, 51, 824.
- Eurema**
lisa, 364.
midea, 364, 365.
patmira, 365.
- Eurrhparodes**, 595,
 625.
bracteolalis, 625, 626.
confusalis, 626.
plumbicimarginalis, 625.
splendens, 626.
stibialis, 626.
syllrepidia, 626, 761.
tricoloralis, 626.
- Eurydemus**
porosicollis, 239.
- Euryphene**
senegalensis, 52.
violacea, 399.
- Euryphura**
achlys, 52.
- Eurytela**
dryope, 53, 400.
fulgurata, 399.
hiarbas, 190.
hyarba, var. *angustata*,
 823.
- Eutelina**
discitriga, 425.
- Eutomus**
micrographus, 333.
sulcatus, 333.
- Euxanthe**
wakefeldi, 399.
- Euxestes**
parki, 336.
piciceps, 336.
- Evergestis**, 603.
- Exeristis**, 602.
- Felis**
caracal, 153, 763.
catus, 153, 155, 157,
 158, 160, 161, 163,
 164, 165, 167, 168,
 171, 173, 177.
dominicanorum, 2, 771.
javensis, 281.
leo, 153, 155, 157, 158,
 160, 161, 163, 164,
 165, 167, 168, 169,
 171, 173, 176, 762.
maniculata, 351.
minuta, 281.
pardalis, 153, 155, 157,
 159, 160, 163, 164,
 165, 168, 169, 171,
 173, 174, 176.
pardus, 153, 155, 157,
 158, 159, 160, 163,
 164, 165, 168, 169,
 171, 173, 174, 762.
serval, 763.
temmincki, 2.
tigris, 153, 155, 157,
 160, 164, 165, 167,
 168, 171, 173.
 (Cynælurus) *jubata*,
 763.
- Filistata**
hibernalis, 893.
- Filodes**, 598, 671.
costivitalis, 671.
cocytusalis, 671.
fulvibasalis, 672, 761.
fulvidorsalis, 671, 672.
patruelis, 672.
productalis, 671, 761.
sexpunctalis, 672.
xanthalis, 672, 761.
- Fratercula**
arctica, 902.
- Fregata**, 82, 83, 84, 85,
 86, 87, 89, 90, 91,
 93, 94, 95, 96, 97,
 98, 99.
ariel, 100, 101.
- Funambulius**
pernyi, 772.
- Fungia**
crassa, 526.
crassitentaculata, 527.
danae, 527.
dentata, 526.
dentigera, 527.
- Fungia**
discus, 526.
echinata, 527.
patella, 526.
tenuifolia, 526.
Furcivena, 602.
- Gadessa**
albifrons, 692.
characteristica, 692.
impuralis, 722.
subalbalis, 692.
- Gadus**
æglefinus, 550, 551,
 566.
luscus, 308, 555.
minutus, 308.
morrhua, 551, 555.
- Galathæa**
affinis, 457, 458, 463.
- Galiëtis**
barbara, 155, 159, 160,
 169, 171.
vittata, 155, 159, 160,
 163, 167, 171.
- Gasteracantha**
falcicornis, 516.
madagascariensis, 388.
resupinata, 516.
sodalis, 388, 391.
tabulata, 516.
- Gavara**
velutina, 437.
- Gazella**
curvici, 353.
dorcis, 353.
leptoceros, 280.
loderi, 353.
pelzelni, 767.
rufffrons, 350.
semmerringi, 767.
spekei, 767.
- Geatractus**, gen. nov.,
 539.
- Gegenes**
hottentota, 200, 912.
letterstedti, 200, 912.
nostradamus, 382.
 —, var. *karsana*, 382.
obumbrata, 200, 912.
- Genetta**
tigrina, 153, 155, 392.
vulgaris, 153, 155, 159.
- Genyomyrus**, 780, 820.
donnyi, 777, 820.
- Geococcyx**
californianus, 48.
- Geomætra**
laterata, 734.
- Geophis**
tecpanecus, 539, 540.

Gerbillus
afer, 392.
böhmi, 392, 393.
 (Gerbilliscus) *fraterculus*, 392.
 (Tatera) *phillipsi*, 765.
Gerrhonotus
monticola, 916.
Gibbium
scotias, 324.
Giraffa
camelopardalis, 39, 40.
 — *capensis*, 41.
 — *peralta*, 40.
 — *typica*, 41, 587.
Globigerina
 sp., 1028.
bulloides, 1028, 1029.
pachyderma, 1028, 1029.
Glutophrissa
contracta, 413.
flavida, 413.
malatha, 413.
Glyphodes, 598, 731.
actorionalis, 742.
advenalis, 734.
equalis, 733.
agathalis, 744.
albiceps, 733.
albicincta, 737.
albifuscalis, 442, 739, 761.
alitalis, 743.
amphitritalis, 741.
annulata, 740.
arachnealis, 735.
argealis, 738.
arguta, 737.
auricollis, 737.
aurocostalis, 733.
ausonia, 740.
badialis, 736.
baldersalis, 735.
basifascialis, 743, 761.
batesi, 747.
bicolor, 742.
bipunctalis, 747.
bivitrals, 731, 743.
bonjongalis, 739.
boscæ, 748.
cæsalis, 747.
calidalis, 644.
callizona, 742.
canthusalis, 747.
celsalis, 740.
chilka, 747.
columbiana, 738.
conclusalis, 742.
confinis, 735.
conjunctalis, 741.
consocialis, 742.

Glyphodes
cosmarcha, 748.
crameralis, 736.
crithealis, 747.
cumalis, 736.
cupripennalis, 740.
deliciosa, 742.
dermatialis, 632.
diurnalis, 742.
dohrni, 736.
doleschali, 741.
dysallactalis, 744.
ectargyralis, 744, 761.
clealis, 442, 739.
elegans, 737.
eribotesalis, 741.
ernalis, 742.
cumeusalis, 735.
eurytusalis, 743.
evippealis, 747.
exaula, 741.
excelsalis, 742.
exclusalis, 736.
fallacialis, 741.
finalis, 736.
flavicaput, 733.
flavizonalis, 746.
flegia, 732.
fraterna, 740.
fumosalis, 736.
fuscicaudalis, 737.
glauculalis, 741.
heliconialis, 742.
hermesalis, 739.
hilaralis, 733.
hyalinata, 369, 738.
hypometas, 740, 761.
imitalis, 733.
incurvata, 736.
indica, 738.
infimalis, 737.
innotata, 739.
isocelalis, 740.
itysalis, 743.
jaculalis, 748.
jarusalis, 733.
lachesis, 741.
lacteata, 744.
lacustralis, 747.
laticostalis, 732.
latilimbalis, 736.
ledereri, 741.
lineata, 736.
lora, 747.
lucidalis, 737.
lustralis, 733.
magdalena, 738.
malayana, 743.
margaritalis, 735.
margaritaria, 736.
marginata, 735.
Glyphodes
marinata, 733.
megalopa, 748.
metastictalis, 741.
microta, 742.
minimalis, 742.
naralis, 744.
negatalis, 733.
nervosa, 740.
nigricollis, 740.
nigropunctalis, 739.
nigroviridialis, 738.
nigirica, 741.
nitidalis, 737.
niveocilia, 738.
nyctealis, 743, 748.
oceanitis, 741.
ocellata, 739.
ochrivitrals, 737.
olealis, 737.
opalalis, 743.
ophiceralis, 732.
orbiferalis, 742.
parvalis, 742.
pedenotata, 742.
perfecta, 741.
perspectalis, 738.
pfeifferæ, 732.
phytonalis, 747.
picticostalis, 740.
pierspersialis, 743.
polyzonalis, 744.
pomonalis, 741.
principalis, 741.
prothymalis, 742.
pryeri, 746.
psittacalis, 733.
pulverulentalis, 744.
punctalis, 741.
punctiferalis, 741.
pyloalis, 746.
quadrifascialis, 744.
quadrifascialis, 742.
quadrifascialis, 739.
reductalis, 741.
sabacusalis, 743.
satanalis, 736.
sectinotalis, 734, 761.
semimigralis, 734.
serenalis, 747.
sericea, 734.
sibillalis, 747.
sinuata, 443, 747.
spectandalis, 747.
spurcalis, 740.
stenocraspis, 442, 444, 739.
stolalis, 744.
streptostigma, 745, 761.
suavis, 749.
superalis, 737.

- Glyphodes**
suralis, 738.
syleptalis, 740, 761.
talangalis, 743, 761.
terminalis, 736.
testudinialis, 728.
thetydalis, 741.
translucidalis, 737.
tricoloralis, 733.
tritonalis, 741.
tumidalis, 742.
umbria, 746, 761.
uncinialis, 651.
unionalis, 739.
univocalis, 636.
vertumnalis, 735.
violalis, 742.
warrenalis, 739.
westermanni, 742.
zambesalis, 738.
zangisalis, 734.
zelimalis, 743.
zelleri, 742.
- Gnamptonyx**
trefoliata, 423.
- Gnaphosa**
anglica, 489.
leporina, 489.
molestia, 488, 489.
- Gnathonemus**, 780, 801.
bentleyi, 801, 804.
curvirostris, 802, 811.
cyprinoides, 777, 801, 805.
elephas, 802, 809, 810.
greshoffi, 802.
livingstonii, 801, 803.
longibarbis, 801, 802, 803.
macrolepidotus, 801, 804.
mento, 801, 807.
mirus, 802, 810.
monteiri, 801, 807.
moorii, 801, 803.
niger, 801, 802.
numenius, 802, 811.
petersii, 801, 808.
rhynchophorus, 777, 802, 810, 821.
senegalensis, 801, 806.
stanleyanus, 801, 806.
tamandua, 777, 802, 809.
ussheri, 802, 808.
- Gnophodes**
diversa, 50.
- Gobius**
minutus, 308, 313.
- Gobius**
niger, 313.
paganellus, 307, 308.
ruthensparri, 298, 302, 313.
- Godartia**
wakefieldi, 399.
- Goliathus**
druryi, 81.
- Gonatodes**
affinis, 455, 913.
africanus, 913.
penangensis, 455.
- Goniorhynchus**, 595, 704.
butyroga, 705.
exemplaris, 705.
flaviguttalis, 705.
gratalis, 706.
marasmialis, 706.
obscurus, 704.
pectinalis, 705.
philenoralis, 706.
plumbeizonalis, 704, 705.
- Gonitis**
involuta, 425.
sabulifera, 425.
- Gonodactylus**
chiragra, 33, 34, 35, 36, 38.
—, var. *smithii*, 33, 35, 38.
cspinosus, 33, 35, 38.
glaber, 36.
glabrous, 33, 36.
graphurus, 36.
oerstedii, 35, 38.
scyllarus, 36.
smithii, 34, 35.
trispinosus, 34.
- Gonodela**
sufflata, 433.
- Gonodiscus**, 594, 606.
amplalis, 606.
australiensis, 606, 761.
- Gonodonta**
hesione, 368.
- Gonyocephalus**
dilophus, 914.
geelvinkianus, 914.
- Goodia**
hollandi, 430, 444.
nubilata, 430.
- Grammodes**
stolida, 422.
- Grandidieria**
ferinensis, 918.
rubrocaudata, 918.
- Gregarina**
blattarum, 244.
- Guereza**
guereza, 587.
occidentalis, 587.
- Gymnarchus**, 780, 821.
niloticus, 777, 779, 821.
- Gymnasterias**
carinifera, 849.
- Gymnodactylus**
affinis, 455.
darmandvillii, 913.
fumosus, 913.
horridus, 913.
jellesmae, 913.
loriae, 913.
pulchellus, 455.
- Gynandrophthalma**
babioides, 219.
basipennis, 218.
bicolor, 217.
deyrollei, 218.
haemorrhoidalis, 218.
incerta, 219.
nitidicollis, 219, 242.
varipes, 218.
venustula, 219.
- Hæmatorithra**
rubrifasciata, 435.
- Halastus**
divitiosus, 424.
- Haliaëtus**
branickii, 280.
- Halomitra**
irregularis, 528, 539.
- Ham anumida**
dædalus, 190, 399, 905.
- Hameopis**, gen. nov., 435.
rudicornis, 435, 444.
- Hapalia**
fraterna, 719.
oblita, 729.
sublutatis, 720.
- Hapalips**
filum, 335.
grouvellei, 334, 343.
- Hapalopus**
incei, 892, 894, 900.
- Haplochilus**
tanganicanus, 497.
- Haritala**
angulifascia, 692.
delicatilis, 728.
discinotalis, 691.
foviferalis, 727.
graphicalis, 728.
tigrina, 691.
- Harpactopus**
 sp., 386.
crudelis, 386.

- Hedylepta**
confusalis, 698.
ochrifuscalis, 698.
pyraustalis, 699.
straminea, 692.
- Heliconius**
charithonia, 363.
- Helictis**
subaurantiacus, 131.
- Heliothela**, 603.
- Heliothis**
armigera, 371.
- Hellula**, 599, 760.
fulvifascialis, 760.
hydralis, 760.
phidilealis, 760.
undalis, 760.
- Helogale**
atkinsoni, 763, 764.
- Hemichromis**
âfer, 142.
angolensis, 136.
auritus, 135.
bimaculatus, 134, 135.
cavifrons, 141.
desguezii, 135.
dimidiatus, 145.
fasciatus, 134, 135.
gigliolii, 143.
guentheri, 149, 150.
guttatus, 136.
intermedius, 145.
jallæ, 141.
leiguardii, 135.
letourneuxii, 136.
livingstonii, 145.
longiceps, 146.
longirostris, 140.
modestus, 144.
retrodens, 142.
robustus, 141.
rolandi, 136.
sacra, 139.
saharæ, 136.
schwebischi, 144, 151.
serranus, 143.
subocellatus, 150.
voltæ, 150.
- Hemidactylus**
isolepis, 913.
jubensis, 913.
macropholis, 913.
ruspolii, 914.
smithii, 913.
squamulatus, 913.
yerberii, 913.
- Hemiscopis**, 600.
- Henucha**
delegorguei, 430.
hansalii, 430.
- Heortia**, 598, 750.
dominalis, 751.
vitessoides, 751.
- Herpænia**
iterata, 413.
- melanarge*, 371, 413.
- Herpestes**
griseus, 153, 155, 167, 170, 172.
nepalensis, 153, 155, 170.
ochraceus, 763.
- Herpetodryas**
carinatus, 115.
fuscus, 116.
grandisquamis, 116.
- Herpetogramma**
servalis, 716.
- Herpetolitha**, 529.
crassa, 529.
- Herpeton**
tentaculatum, 852.
- Hesperia**
diomus, 371.
jucunda, 382.
mafa, 199.
philippus, 407.
plinius, 404.
syrictus, 367.
- Heterarthron**
femorale, 328.
- Heterocentrotus**
mammillatus, 850.
- Heterochæta**
abyssalis, 541, 543.
spinifrons, 543, 548.
- Heterocnephæ**, 596, 627.
atropygialis, 627.
lubricosa, 627.
lunulatis, 627.
lymphatilis, 627.
scapularis, 627.
strangulalis, 651.
vicinialis, 627.
- Heteropacha**
sp., 436.
rileyana, 436.
- Heteropoda**
venatoria, 519.
- Hileithia**, 596, 646.
appialis, 646.
decostalis, 646.
ductalis, 647.
- Himantodes**
cenchoa, 116.
- Hippocamelus**
bisulcus, 212.
- Hippolyte**
gibberosus, 1009.
gibbosus, 1009.
hemprichii, 1009.
- Hippolyte**
marmoratus, 1009.
- Hipposideros**, 75.
- Hippotragus**
bakeri, 127.
cyrinus, 127, 349, 350, 850.
rufo-pallidus, 850, 851.
- Holodactylus**
africanus, 914.
- Holothuria**
affinis, 840.
amboinensis, 839.
aphanes, 841.
arenicola, 842.
atra, 835, 838, 839, 840.
—, var. *amboinensis*, 839, 840.
botellus, 840.
curiosa, 837, 838.
depressa, 837, 838.
floridana, 840.
fuscocinerea, 835, 837, 838.
—, var. *pervicax*, 837, 848.
impatiens, 835, 840, 841.
lagenæ, 842.
maculata, 835, 842.
mammiculata, 837, 838.
mauritiana, 835.
monacaria, 835, 841.
pardalis, 835, 839.
pervicax, 835, 837, 838.
rugosa, 835, 839, 848.
subditiva, 837.
vagabunda, 835, 838, 842.
- Homaloceranium**
melanocephalum, 117.
- Homarus**
vulgaris, 954.
- Homopholis**
heterolepis, 914.
- Homophysa**, 594, 607.
albolineata, 607.
bilinealis, 608.
crambidalis, 608.
decisa, 608.
dotatalis, 608.
fulcatalis, 608.
fulminalis, 607.
glaphyralis, 607.
invisalis, 607.
lentiflualis, 607.
leucostictalis, 608.
micalis, 608.
polycyma, 607, 761.
reniculalis, 607.
sesquistriatalis, 607.

- Hyæna**
brunnea, 154, 175, 185.
crocuta, 154, 156, 157,
 158, 159, 160, 163,
 164, 165, 166, 167,
 169, 171, 172, 173,
 177, 185, 764.
striata, 153, 154, 156,
 158, 159, 160, 163,
 164, 165, 166, 167,
 169, 171, 172, 173,
 175, 177, 185, 764.
- Hyaena**, 596, 641.
dividualis, 641, 642.
fulvidialis, 644.
glaucoptidialis, 642.
melanalis, 632.
pallidialis, 642, 761.
succinalis, 642.
- Hyalitis**
tagesalis, 631.
- Hyalobathra**, 601.
- Hydrocampa**
albofascialis, 623.
dematricalis, 614.
felia, 624.
laothocalis, 605.
laudamialis, 605.
stenioides, 624.
tenera, 651.
- Hydrochærus**
capibara, 73.
- Hydrophis**
fasciatus, 107.
floweri, 106.
mamillaris, 107.
- Hyla**, 103.
baudinii, 124.
everetti, 478.
fallax, 478, 482.
gabbii, 478.
gratiosa, 478.
impura, 478.
leucophyllata, 482.
maxima, 124.
microcephala, 478, 481,
 482.
puma, 478.
rosenbergi, 123, 126,
 478.
rueppellii, 478.
uranochroa, 481.
variabilis, 478.
- Hylambates**
johnstoni, 475.
- Hylella**
parabambæ, 125, 126,
 478.
puncticrus, 478.
- Hylephila**
phylæus, 367.
- Hylobates**
syndactylus, 588, 924.
- Hyloides**
achatinus, 120, 126,
 477.
alfredi, 477, 480, 482.
anomalous, 119, 126,
 476.
bufoniformis, 477.
cerasinus, 477.
conspicillatus, 120.
discoidalis, 477.
erythropleura, 477.
gularis, 121, 126,
 477.
latidiscus, 121, 126,
 477.
longirostris, 120, 126,
 477.
palmatus, 120.
polyptychus, 477.
raniformis, 120, 476.
ranoides, 476.
rugosus, 477.
underwoodi, 477.
- Hymenia**
diffascialis, 623.
crebina, 715.
phrasiusalis, 623.
- Hypanartia**
schœneia, 824.
- Hypanis**
acheloia, 376.
cora, 375.
ilithyia, 376.
- Hypena**
masurialis, 426.
vulgatalis, 426.
- Hyperaspis**
cincticollis, 340.
connectens, 340.
festiva, 340.
- Hyperia**
oblivia, 583.
- Hyperopisus**, 780, 819.
bebe, 777, 819.
dorsalis, 820.
occidentalis, 820.
- Hyperythra**
lucicolor, 383.
- Hypocala**
deflorata, var. *plumicornis*, 424.
plumicornis, 424.
- Hypocheiria**
io, 80.
- Hypogeophis**
alternans, 479.
- Hypolimnas**
missippus, 51, 190, 370,
 379, 398.
- Hypolycæna**
pachalica, 407.
- Hyrax**, 58.
- Hyreus**
lingeus, 194.
- Ibacus**
antarcticus, 1014.
- Ictonyx**
libyca, 155, 158, 159
 160, 163, 166, 167
 171, 175, 177.
zorilla, 155, 163.
- Idessa**
pyrgionalis, 749.
- Idiommata**
lepida, 506.
- Idiops**
compactus, 508.
- Idiurus**
macrotis, 450, 452, 453.
- Idunais**
venosa, 411.
- Ileina**
robusta, 428.
- Imbrasia**
epimeathea, 80, 81.
- Iolaus**
buxtoni, 54.
cæculus, 197.
pachalicus, 407.
pallene, 54.
philippus, 54, 407, 826.
silarus, 407.
- Iomachus**
politus, 498, 499.
- Ischnurges**, 601.
- Ischyurus**
flavitaris, 335.
fulvitaris, 335.
graphicus, 335.
modestus, 335.
subcylindricus, 335.
 (Oocyanus) *tarsalis*,
 335.
- Isichthys**, 780, 791.
henryi, 777, 791.
- Isometrus**
burdoi, 500.
- Isopteryx**
abnegatalis, 626.
accessalis, 626.
bilunatalis, 694.
flavofuscalis, 727.
plumbalis, 626.
sodidalis, 694.
trisinata, 624.
xentolalis, 701.
- Ixalus**
bimaculatus, 475.
leitensis, 475.

- Ixalus**
mindorensis, 475.
vittiger, 475.
- Julidochromis**, gen. nov.,
495.
ornatus, 495.
- Junonia**
actia, 51, 822.
archesia, 188, 904.
artaxia, 51, 190.
aurorina, 189, 397,
398.
boopis, 52, 904.
calescens, 189, 904.
cebrene, 370, 398, 822.
clelia, 51, 190, 369,
379, 398, 822, 826.
cuama, 51, 189, 398,
904.
elgiva, 51, 189.
epiclelia, 379.
guruana, 397.
here, 822.
limnoria, var. *taveta*,
397.
nachtigali, 190.
natalica, 189, 398,
904.
octavia, 822.
—, var. *natalensis*, 189,
904.
orthosia, 822.
pelasgia, 188, 397.
puriformis, 822.
pyriformis, 398.
sesamus, 189, 824, 904.
simia, 189, 904.
trimeni, 189.
tugela, 189, 398.
- Kedestes**
macomo, 200, 902, 911,
912.
niveostriga, 200.
tucusa, 200.
wallengrenii, 200.
- Kerivoula**
pellucida, 76.
- Kobus**
vardoni, 394.
- Labidura**
riparia, 384.
- Labrus**
maculatus, 308.
mixtus, 308.
niloticus, 132.
- Lacerta**
mosorensis, 916.
- Lachesis**
atrox, 118.
lansbergii, 118.
schlegelii, 118.
- Lachnea**
fulvicollis, 222.
- Lachnocnema**
bibulus, 195, 825,
826.
darbani, 195.
- Lachnoptera**
ayresii, 399.
- Lacipa**
gracilis, 427, 428.
impuncta, 428, 444.
- Lacydes**
arborifera, 417.
gracilis, 417, 444.
smithi, 417.
vocula, 417, 418.
- Laganum**
depressum, 850.
- Lagropia**
xanthomela, 729.
xanthozonalis, 727.
- Lampoxanthium**
murrayanum, 1024.
- Lamprologus**
compressiceps, 494.
congoensis, 134.
elongatus, 494.
fasciatus, 494.
fulcifera, 494.
modestus, 494.
moorii, 494.
- Lampyrus**
ignita, 319.
- Landreva**
sp., 385.
- Laniifera**, 603.
- Laphygma**
macra, 368.
- Lasiacme**
mimica, 639.
pilosa, 639.
- Lasiocampa**
köllikeri, 436.
monteiri, 80.
prompta, 436.
- Lasioderma**
puberulum, 326.
serricorne, 326.
testaceum, 326.
- Lasioptila**
ansorgei, 431.
pomona, 431.
- Latastia**
hardeggeri, 916.
neumanni, 916.
- Latastia**
phillipsii, 916.
- Lates**
microlepis, 494.
niloticus, 494.
- Lebeda**
köllikeri, 436.
nobilis, 436.
- Ledereria**
seppalis, 704.
- Lema**
angusto-marginata,
214.
australis, 213.
cyaneoplagiata, 214,
242.
dregii, 213.
emarginata, 213.
lateritia, 215.
mashuana, 214.
pauperata, 215.
picticollis, 213.
pubifrons, 215.
reginbarti, 212.
robusta, 213.
- Lembopteris**, gen. nov.,
438.
puella, 438, 444.
- Lepadogaster**
bimaculatus, 589.
stictopteryx, 589.
- Lepidoblepharis**
festæ, 108, 914.
- Lepidodactylus**
gardineri, 914.
- Lepidogma**
sp., 441.
- Lepidoneura**, 599.
- Lepidosiren**, 41, 42, 43,
492.
paradoxa, 852, 853.
- Leptobranchium**
natunæ, 478.
- Leptodactylus**
maculilabris, 477.
pentadactylus, 122.
pulcher, 122, 126,
477.
- Leptodira**
annulata, 117.
- Leptognathus**
ellipsifera, 117, 126.
- Leptomyrina**, gen. nov.,
405.
hirundo, 406.
phidias, 405.
rabe, 405.
- Leptoneura**
bowkeri, 903.
clytus, 903.
dingana, 903.

- Leptophis**
bocourti, 116.
lioceris, 116.
- Leptosoma**
fallax, 419.
leuconoe, 57, 419.
- Lepus**
diastolus, 360.
hypsius, 360, 361.
macrotus, 359, 360.
oistolus, 357, 358,
 359, 360, 361.
pallipes, 357, 358, 359,
 360, 361.
ruficaudatus, 359.
sinensis, 775.
- Lepyrodes**, 598, 753.
astomalis, 651.
capensis, 443, 754.
geometralis, 443, 754.
piabilis, 754.
puerelia, 753, 754.
quadrinalis, 754.
- Letis**
mycerina, 368.
- Leuceronia**
argia, 56, 198.
buquetii, 413.
thalassina, 822.
- Leucinodes**, 598, 755.
apicalis, 756.
auxialis, 755.
diaphana, 756.
discrptalis, 756.
elegantalis, 756.
erosialis, 756.
exemptalis, 760.
heranicealis, 755.
imperialis, 756.
impuralis, 756.
lucealis, 756.
opalina, 630.
orbonalis, 756.
vagans, 756.
venustalis, 760.
- Leuckartia**
flavicornis, 543, 548.
- Leucochroma**, 596,
 642.
corope, 642.
melusinalis, 642.
mineralis, 642.
prosalis, 633.
ruscialis, 645.
saltigalis, 643.
subpurialis, 605.
- Leucophotis**, 597, 667.
pulchra, 667.
- Lexis**
bipunctigera, 418,
 419.
- Libythea**
fulgurata, 399.
- Limenitis**
disippus, 80.
- Limnas**
chrysippus, 50, 373,
 379.
 —, var. *alcippoides*,
 379.
 —, var. *dorippus*,
 373, 396.
 —, var. *klugi*, 396,
 826.
klugi, 369, 396, 822.
- Linekia**
miliaris, 849.
multifloris, 849.
- Lineodes**, 603.
- Linyphia**
pusilla, 488.
- Liocephalus**
guentheri, 114.
- Liopasia**, 600.
- Liophis**
albiventris, 116.
- Liophryne**
brevis, 476.
rhododactyla, 476.
- Lipocosma**, 594, 611.
fuliginosalis, 612.
hebescalis, 612.
nigripictalis, 612.
sicalis, 611, 612.
- Liposarcus**
pardalis, 492.
- Lithocranium**
walleri, 767.
- Lithosia**
bipunctigera, 418.
vetusta, 383.
- Lizzia**
blondina, 1023, 1030.
- Lœtrina**
flexalis, 614.
- Lomotropa**
vellerialis, 750.
- Lopera**
monosticta, 428, 444.
pallada, 428.
- Lophomonas**
blattarum, 242, 243,
 244.
sulcata, 243, 244.
striata, 243.
- Lophoseris**, 529.
cristata, 530.
- Lophostethus**
demolinii, 432.
- Lophotriorchis**
lucani, 2.
- Loxoneptera**, 602.
- Lucidota**
dimidiatipennis, 320.
janthinipennis, 320.
miniatocollis, 320.
- Ludia**
kansalii, 430.
- Lutra**
capensis, 392.
cinerea, 155, 158, 160,
 169, 171, 178.
maculicollis, 392.
vulgaris, 155, 158, 177,
 186.
- Lycæna**
gaika, 404.
jesous, 370.
jobates, 404.
kersteni, 405.
knysna, 370.
larydas, 405.
livia, 406.
lysimon, 380.
melena, 404.
niobe, 187.
osiris, 403.
parsimon, 192.
patricia, 192, 370.
perpulchra, 403.
sichela, 404.
trochilus, 370.
- Lycænesthes**
adherbal, 194, 907.
amarah, 194, 370,
 405.
lodes, 194.
otacilia, 194.
princeps, 370.
sylvanus, 405.
- Lycæon**
pictus, 154, 159, 169,
 173, 186.
- Lycœtenus**, 27.
columbianus, 900.
palustris, 893, 899,
 900.
- Lycœrea**
cleobæa, 363.
- Lycosa**
albata, 488.
amentata, 488.
blanda, 488.
cursoria, 488.
palustris, 488.
prativaga, 491.
pullata, 490.
riparia, 487, 488, 490,
 491.
 (Pardosa) *riparia*, 487,
 490.
- Lycyctus**
prostomoides, 328.

Lygosoma

- aignanum*, 917, 921, 923.
alfredi, 918, 922, 923.
bipes, 918.
brevipes, 917.
celebensis, 917.
curtum, 917.
elegans, 917.
everetti, 917.
ferrandii, 918.
gastrostigma, 918, 292, 923.
guineense, 918.
iridescens, 917.
johnstoni, 917.
kuekenthali, 917.
longiceps, 917.
loriæ, 917.
maindroni, 917.
miotis, 917.
nigrigulare, 917.
nigrolineatum, 917.
parietale, 917.
quadrivittatum, 918.
sarasinorum, 917.
semoni, 917.
sorex, 917.
stanleyanum, 917.
subnitens, 917.
tetratænia, 917.
textum, 917.
virens, 917.
- Lygropia**, 595, 726.
amplificata, 729.
amyntusalis, 442, 728.
arenacea, 729.
armeniacaalis, 728.
bilinealis, 729.
bipunctialis, 728.
calanticalis, 729.
cernalis, 728.
chromalis, 728.
clytusalis, 728.
distorta, 729.
ericantha, 728.
euryclealis, 729.
flavicaput, 727.
flavispila, 729.
fuscicostalis, 728.
imparalis, 727.
lelex, 727.
muscerdalis, 728.
neglectalis, 723.
nigricornis, 728.
nigrofimbriatis, 729.
obrinusalis, 728.
pharaxalis, 729.
poltisalis, 729.
polytesalis, 729.

Lygropia

- pompusalis*, 728.
prognealis, 730.
ptochura, 729.
quaternalis, 726, 728.
rivulalis, 727.
scybalistia, 730.
simplialis, 728.
strigilalis, 727.
unicoloralis, 727.
- Lysiosquilla**
maculata, 33, 37.

Mabuia

- megalura*, 917.
novemcarinata, 917.
planifrons, 917.
tessellata, 917.

Macacus

- assamensis*, 361.
leoninus, 280.
pelops, 361.
rhesus, 361, 770.
villosus, 361.

Macalla

- sp., 441.
Macaretaera, 598, 669.
hesperis, 669, 670.

Macaria

- sufflata*, 433.

Macrodon

- trahira*, 492.

Macroglossa

- hirundo*, 432.

Macropus

- rufus*, 80.

Macroscelides

- revoili*, 762.

Madoqua

- cavendishi*, 278, 279.
damarensis, 278, 279.
guentheri, 278.
kirkii, 278.
phillipsi, 278, 767.

Madrepora

- angulata*, 262.
arenosa, 272.
aspera, 260.
austera, 259.
beodactyla, 262.
boletiformis, 530.
contigua, 536.
crateriformis, 258, 276.
cristata, 530.
cuneata, 262.
dijitata, 996.
fruticosa, 262.
gemmifera, 262.
hebes, 261.

Madrepora

- hispidata*, 261.
latistella, 261.
loripes, 262.
monticulosa, 261.
patella, 526.
polymorpha, 262.
profunda, 260, 276.
pulchra, 259.
 —, var. *alveolata*, 259.
reticulata, 260.
robusta, 259.
rotumana, 258, 276.
scabrosa, 260.
secunda, 258.
securis, 261.
seriata, 262.
sinensis, 261.
smithi, 259.
surculosa, 261.
- Mæandroseris**, 533.
bottæ, 534, 535.
- Malea**
ringens, 461.
- Malegia**
affinis, 227.
obscurella, 227.
striatula, 227.
- Mallotus**
villosus, 291, 560, 562, 563, 564, 566.
- Mamestra**
opposita, 420.
- Mantidactylus**
albofrenatus, 475.
majori, 475.
- Mantophryne**
lateralis, 476.
robusta, 476, 480, 482.
- Marasmalus**
discistriga, 425.
- Marasmia**, 596, 638.
aurea, 639.
bilinealis, 639.
cicatricosa, 639.
cochrusalis, 639.
exigua, 639.
fuscifascialis, 639.
hemicrassa, 639.
latimarginalis, 639.
trapezalis, 639.
trehiusalis, 639.
veniliialis, 638.
- Marcusenius**, 780, 792.
adpersus, 792, 795.
anguilloides, 782.
brachyhystius, 792, 793.
discorhynchus, 777, 792, 797.
isidori, 792, 798.
kingsleyæ, 792, 794.

- Marcusenius**
lhuysii, 792, 795.
marchii, 792, 793.
pauciradiatus, 792, 795.
petherici, 792, 797.
plagiostoma, 777, 792, 796.
psittacus, 792, 798.
sphecodes, 792, 793.
wilverthi, 777, 792, 796.
- Maretia**
planulata, 850.
- Margarodes**
berytalis, 747.
minor, 747.
nereis, 741.
nitidicostalis, 732.
phantasmalis, 732.
septempunctalis, 739.
squamopedalis, 735.
transvisalis, 739.
tritonias, 747.
- Margaronia**
amphitratalis, 741.
angustalis, 748.
aquosalis, 733.
atlitalis, 735.
auricostalis, 733.
canastralis, 740.
claralis, 739.
congradalis, 734.
convolvulalis, 747.
eribotalis, 740.
herbidalis, 735.
leodicealis, 732.
maliferalis, 733.
marthesiusalis, 741.
melanuralis, 735.
morvusalis, 735.
neomera, 739.
phryneusalis, 735.
plumifera, 668.
proximalis, 735.
usitata, 740.
virginalis, 732.
woodfordii, 738.
- Maruca**, 600.
- Massepha**, 594, 615.
absolutalis, 615, 616.
bengalensis, 616.
carbonalis, 616.
entephradia, 616.
fulvalis, 616, 761.
gracilis, 616.
grammalis, 616.
phænicobapta, 615, 761.
- Mastacembelus**
moorii, 496.
- Mecistes**
indigaceus, 235.
tarsalis, 236.
- Mecyna**, 599.
- Megadyptes**
antipodum, 959, 960, 963, 964, 988.
- Megalixalus**
brachyencemis, 475.
gramineus, 475.
- Megaphysa**, 603.
integralis, 731.
serenalis, 723.
- Megastes**, 603.
- Megilla**
maculata, 339.
- Melanitis**
libya, 50.
solandra, 50, 397, 823.
- Meles**
taxus, 155, 156, 159, 160, 163, 185.
- Melitonona**
marshalli, 216, 242.
- Mellivora**
ratel, 765.
- Menius**
chalceatus, 239.
- Menobanchus**
lateralis, 856.
- Meroctena**, 603.
- Mesocondyla**, 597, 666.
concordalis, 666.
dardusalis, 666.
stigmatalis, 666.
tarsibarbalis, 667.
- Meta**
ungulata, 513.
- Metabæteus**, gen. nov., 1014.
minutus, 1000, 1014.
- Metaculasta**, gen. nov., 444.
dives, 444.
- Metapenæus**
commensalis, 1001, 1015.
coniger, 1002.
philippinensis, 1002.
rectacutus, 1002.
- Metaprotus**, 604.
- Metasia**, 602.
 sp., 383.
achromatias, 703.
lilliputalis, 702.
zanclogramma, 695.
- Metasiodes**
apicalis, 703.
calliophis, 702.
- Metrea**, 598, 757.
aripanalis, 757, 761.
- Metrea**
nebulalis, 757.
ostreonalis, 757, 758.
- Metridia**
armata, 547, 549.
longa, 543, 546, 547, 579.
- Micaria**
publicaria, 488.
- Mieranobium**
exiguum, 325.
publicarium, 325.
- Microcausta**, 599.
- Microcossus**
bettoni, 443.
mackwoodi, 443.
- Microhierax**
melanolencus, 2, 128.
- Microhyla**
bungurana, 476.
palmipes, 476.
- Microneta**
fuscipalpis, 488.
- Microtus**
melanogaster, 775.
- Millepora**
alcicornis, 250, 252, 253, 256, 828, 831.
complanata, 250, 252, 830, 833.
dichotoma, 829.
esperii, 829, 830.
intricata, 249, 253.
murrayi, 250, 251, 252.
nodosa, 829.
plicata, 249, 252, 831, 833.
ramosa, 828, 829, 830, 831, 832.
striata, 251.
tuberculata, 251.
tuberculosa, 253.
undulosa, 828.
verrucosa, 249, 251, 253.
- Mimasarta**, 600.
- Mimetozone**
craspedotus, 914.
- Mimorista**
marginalis, 652.
salaconalis, 704.
- Minopterus**, 75.
schreibersii, 74, 78.
- Miopristis**
atrofasciatus, 221.
pusilla, 220, 242.
- Miresa**
syrtis, 437.
- Mirobriga**
albicans, 614.

- Mirosternus**
lævis, 327, 333.
- Mnesictena**, 601.
- Molge**
alpestris, 485, 486.
blasii, 127.
boscæ, 487.
cristata, 127.
cristata × *marmorata*,
 127.
italica, 478, 482, 487.
marmorata, 127.
montandoni, 484, 487.
palmata, 484, 487.
vulgaris, 483, 484, 485,
 486, 487.
 — *meridionalis*, 486,
 487.
- Molossus**
temmincki, 78.
- Momotus**, 89.
- Monandroptera**
inuncans, 943, 954.
- Monocona**, 602.
- Monocoptera**, gen. nov.,
 596, 610.
cmetallescens, 610.
- Montipora**
caliculata, 267.
 —, var. *piriformis*, .
 267.
columnaris, 257, 265,
 276.
foveolata, 266.
granifera, 267.
incognita, 267.
irregularis, 266.
profunda, 267.
saxea, 267.
socialis, 266.
verrucosa, 267.
- Mormyrops**, 780.
anguilloides, 777, 781,
 782.
attenuatus, 781, 786.
breviceps, 781, 783.
cyprinoides, 805.
deliciosus, 777, 781.
elongatus, 805.
engystoma, 781, 784.
henryi, 791.
labiatus, 805.
lincolatus, 781, 785.
longiceps, 781, 783.
macrolepidotus, 804.
mariae, 781, 786.
masuianus, 781, 784.
microstoma, 781, 786.
sirenoides, 781, 785.
sphécodes, 793.
tuckeyi, 781.
- Mormyrops**
zambanenje, 777, 782.
zancirostris, 777, 781,
 783.
- Mormyrus**, 780, 812.
abbreviatus, 805.
adpersus, 795.
affinis, 799.
anchietæ, 812, 814.
bachiqua, 817.
bane, 788.
bebe, 819.
bentleyi, 804.
bovei, 789.
brachyestius, 793.
caballus, 813, 818.
caschive, 777, 813,
 815.
castostoma, 790.
cobitiformis, 791.
cyprinoides, 779, 788,
 805.
dendera, 782.
dequesne, 788.
discorhynchus, 797.
dorsalis, 819.
chrenbergii, 788.
elongatus, 805.
geoffroyi, 816, 817.
gliroides, 790.
grandisquamis, 803.
greshoffii, 809.
guentheri, 812, 814.
hasselquistii, 812, 813.
henryi, 791.
herse, 813.
hildebrandti, 818.
isidori, 798.
joannisii, 788.
jubelini, 813, 816.
kannume, 777, 813,
 817.
kingsleyæ, 794.
labiatus, 805.
lacerdæ, 815.
lepturus, 803.
lhuysii, 795.
liberiensis, 794.
longibarbis, 802.
longipinnis, 779, 815.
longirostris, 813, 817.
macrolepidotus, 804.
macrophthalmus, 812,
 815.
marchei, 793.
mento, 807.
microcephalus, 794.
monteiri, 807.
moorii, 803.
mucupe, 817.
niger, 802.
- Mormyrus**
niloticus, 813, 816.
ovis, 812, 815.
oxyrhynchus, 817.
pauciradiatus, 795.
petersii, 808.
proboscirostris, 813,
 818.
psittacus, 798.
rumæ, 813, 816.
salahie, 805.
senegalensis, 806.
simus, 790.
sphécodes, 793.
stanleyanus, 806.
tamandura, 809.
tenuicauda, 789.
tenuirostris, 813, 819.
tuckeyi, 781.
ussheri, 808.
walkeri, 799.
zambanenje, 781, 782.
zancirostris, 783.
 (Isistius) *henryi*, 791.
 (Mormyrops) *mariae*,
 786.
 (—) *swanenburgi*,
 782.
 (—) *zambanenje*, 782.
 (Petrocephalus) *saw-*
agii, 788.
 (—) *simus*, 789.
- Morocosina**
polybapta, 736.
- Morone**
labrax, 308.
- Mülleria**
echinites, 836.
flavocastanea, 836.
parvula, 836.
varians, 836.
- Murina**
leucogastra, 771.
- Mus**
agrarius, 774.
 — *manichuricus*, 774.
 — *typicus*, 774.
arianus, 361.
callosus, 211.
chevrieri, 773.
confucianus, 773.
coxingi, 773.
decumanus, 772.
edwardsi, 773.
harti, 774.
humiliatus, 772.
jérdoni, 773.
latouchei, 769, 772.
musculus, 210.
pygmæus, 775.
niger, 802.

Mus

- flavipectus*, 772.
nitidus, 773.
sylvaticus, 773.

Musca

- vomitorea*, 957.

Mustela

- flavigula*, 771.
joia, 155, 156, 158,
 160, 163, 165, 166,
 169, 171, 185.
putorius, 155, 167, 169,
 171, 175.

Mycalesis

- anymana*, 374.
caffra, 50, 396.
ena, 903.
evenus, 396.
perspicua, 396.
safitza, 50, 396, 903.
selousi, 188, 903.

Myctophum

- glaciale*, 552.

Mygale

- plumipes*, 899.

Mylothris

- agathina*, 55, 370, 407,
 822, 908.
lasti, 412.
rüppellii, 197.
swaynei, 822.
zulei, 822.

Myomyrus, 780, 800.

- macrodon*, 777, 800.

Myotis

- murinus*, 75.

Myrina

- ficedula*, 54, 195, 908.
lorisona, 406.
silenus, 405.

Mystacina

- tuberculata*, 58.

Nacaduba

- sichela*, 194, 404,
 907.

Nacoleia, 597, 693.

- accepta*, 699.
albiflavatis, 701.
allocosma, 694.
amphicedalis, 694.
apicalis, 701.
apygalis, 701.
aurantifascialis, 699.
aurotinctalis, 698.
barbata, 696.
batracialis, 701.
benepictalis, 700.
blackburni, 699.
canacealis, 698.
charesalis, 703.

Nacoleia

- chlorura*, 695.
chrysanthes, 697.
cirrosalis, 696.
coatepecensis, 702.
cæneusalis, 702.
colubralis, 702.
commixta, 694.
confusalis, 698.
continentalis, 699.
costisignalis, 694.
cuprealis, 699.
cyanealis, 695.
cylonalis, 701.
dairalis, 697.
demaratalis, 699.
didasalis, 703.
diemenalis, 699.
dorsalis, 697.
ebulealis, 701.
eximialis, 703.
fusalis, 702.
fuscifimbrialis, 699
hcliaula, 702.
holophæa, 695.
iarchasalis, 696.
indicata, 699.
insolitalis, 700.
junctithyralis, 701,
 761.
kingdoni, 700.
lacertalis, 702.
ladonalis, 698.
leonina, 702.
leucostrepta, 698.
localis, 699.
lunidiscalis, 700.
lunulalis, 697.
major, 703.
marionalis, 695.
mellealis, 696.
mesochlora, 695.
mesodora, 697.
moninalis, 702.
murcusalis, 694.
niphealis, 698.
obliqualis, 695.
optasema, 703.
œaxalis, 702.
olivia, 700.
ossea, 703.
pallidipennis, 701.
pantheralis, 704.
parasephis, 694.
pedicialis, 703.
pelealis, 698.
perdentalis, 697.
perfenestrata, 701.
persimulalis, 701.
phaleasalis, 703.
photias, 696.

Nacoleia

- pæonalis*, 694, 698.
præritalis, 695.
progonialis, 696, 761.
puncticostalis, 702.
ranalis, 702.
rhealis, 703.
rhæoalis, 694.
rubralis, 701.
rusterminalis, 703.
salbialis, 699.
scitalis, 701.
semicostalis, 700, 761.
stenialis, 703.
stigmatilis, 699.
subargentalis, 697.
subulalis, 694.
tampiusalis, 702.
tholeropea, 704.
tiasalis, 695.
tricrossa, 695.
tristrialis, 698.
valvata, 696.
vestalialis, 701.
vilialis, 702.
vittifera, 699.
vulgaris, 699.
xanthialis, 700.
zoilusalis, 696.
- Nagia**
desmialis, 724.
incomitata, 662.
- Nasua**
fusca, 154, 159, 160,
 163, 169.
narica, 154, 159, 160,
 163, 169, 172, 185.
rufa, 154, 163, 171.
- Neotophryne**
everetti, 477.
macrotis, 477.
- Neda**
delaneyi, 340.
viridula, 340.
- Nedusia**
multilaria, 368.
- Neocænura**
duplex, 188.
extensa, 188, 201.
gregorii, 188.
- Neolycæna**
cissus, 193, 907.
- Nephelodes**
finifascia, 424.
- Nepheleuca**
politia, 368.
- Nephila**
argyrotoxa, 508.
bennetti, 387, 391.
cornuta, 893.
femorialis, 388.

- Nephila**
keyserlingii, 388.
madagascariensis, 508.
pilipes, 509.
sumptuosa, 388, 508.
- Nephopteryx**
 sp., 383.
- Neptis**
agatha, 53, 190, 399,
 822, 905.
marpessa, 399.
- Nereis**
diversicolor, 306.
- Nesophora**
latiferalis, 664.
obliqualis, 662.
ochnodes, 662.
panaresalis, 664.
parvipunctalis, 662.
quadrisignata, 663.
scotaula, 662.
semitritalis, 663.
triguttalis, 662.
- Nesotragus**
livingstonianus, 394.
- Neurophyseta**, 594, 605.
clymenalis, 605.
- Nevrina**, 597, 675.
procopia, 676.
- Nicoria**
annulata, 108.
- Nilus**
curtus, 31.
- Niphadolepis**
auricincta, 437, 444.
- Noctilio**
leporinus, 75, 76.
- Noctua**
repanda, 424.
stolida, 422.
- Noctuella**, 602.
- Nodaria**
externalis, 426.
- Nomophila**, 601.
- Noorda**, 599.
- Nosophora**, 597, 661.
albigitialis, 662.
atthealis, 661, 663.
barbata, 663, 761.
chironalis, 662.
conjunctalis, 662.
dispilalis, 662.
euspilalis, 662.
flavibasalis, 663, 761.
fulvalis, 663.
hypsalis, 663.
- Notarcha**
butyrina, 721.
chrysoplasta, 728.
compsogramma, 691.
dubia, 721.
- Notarcha**
exculta, 725.
halurga, 713.
paucinotalis, 725.
semiflava, 729.
tenuis, 723.
triparalis, 711.
- Nototrema**
angustifrons, 124, 126,
 478.
bolivianum, 478.
cornutum, 124, 126,
 478.
marsupiatum, 124.
oviferum, 125.
- Nychitona**
medusa, 407.
 —, var. *alcesta*, 55,
 197, 407.
xiphia, 407.
- Nyctemera**
fallax, 419.
leucoconö, 419.
- Nycticorax**, 85.
- Nyctimantis**
papua, 478.
- Nyctinomus**, 59.
- Nyctiphanes**
norvegica, 578, 585.
- Nyctophilus**
timorensis, 78.
- Nyctotherus**
ovalis, 244.
- Nymphalis**
neanthes, 397.
zoolina, 397.
- Ochlodes**
pustula, 367.
- Odontodactylus**
scyllarus, 33, 36, 38.
- Odonturus**
dentatus, 499.
- Oecodoma**
cephalotes, 81.
- Oeonistis**
quadra, 419.
- Ogoa**
simplex, 427.
- Oithina**
spinifrons, 541, 543.
- Oligocentris**, 597, 687.
deciusalis, 687, 688.
- Oligostigma**
incommoda, 382.
- Omiodes**
heterogenalis, 686.
hiracia, 684.
leporalis, 684.
liodyta, 704.
monogona, 704.
- Omiodes**
nigriscripta, 679.
pallicostalis, 685.
scabripennis, 686.
- Ommatospila**, 599, 759.
descriptialis, 759, 760.
narcæusalis, 760.
nummulalis, 760.
- Omocena**
syrtis, 437.
- Omphisa**, 603.
- Oocyaneus**
violaceus, 335.
- Ophiactis**
savignii, 849.
- Ophiarthrum**
elegans, 849.
pictum, 849.
- Ophideres**
divitiosa, 424.
- Ophidiaster**
cylindricus, 849.
- Ophiocoma**
erinaceus, 849.
scolopendrina, 849.
- Ophiodes**
finifascia, 424.
- Ophiolepis**
cincta, 849.
- Ophioplocus**
imbriatus, 849.
- Ophiuche**
masuralis, 426.
- Ophiusa**
abnegans, 422.
angularis, 422.
lienardi, 422.
- Oreas**
canna, 281.
 — *livingstonei*, 394.
derbianus, 349, 350.
- Orenaia**, 603.
- Oreobatrachus**
baluensis, 474.
- Oreophrynella**
quelchii, 476.
- Orobena**
reluctalis, 608.
- Orphanostigma**
versicolor, 645.
- Orthoraphis**, 594, 604.
metasticta, 604.
obfuscata, 604.
- Oryx**
beisa, 768.
leucoryx, 280, 281, 350,
 352.
- Oryzomys**
venustus, 211.
- Osteoglossum**
leichardti, 493.

- Ourebia**
nigricaudata, 350.
- Oxybelis**
acuminatus, 117.
brevirostris, 117.
- Oxydoras**
bachii, 44.
elongatus, 44.
trachyparia, 44.
trimaculatus, 44.
- Oxyglossus**
martensii, 474.
- Oxypalpus**
harona, 199.
ruso, 199.
- Oxyrhynchus**
deliciosus, 781.
- Pachyarches**
tibialis, 735.
- Pachydactylus**
affinis, 914.
- Pachynoa**
megapteralis, 685.
opalinalis, 685.
- Pachysmopoda**
abbreviata, 384.
- Pachyzancla**, 601.
ægrotalis, 369.
granulata, 698.
- Pagurus**
aniculus, 461.
asper, 460.
clypeatus, 459.
corallinus, 463.
decorus, 461.
deformis, 458, 460.
elegans, 461.
euopsis, 457, 461.
gaimardii, 462.
gemmatus, 460.
guttatus, 461.
levimanus, 462.
latens, 463.
latro, 458.
lividus, 462.
pedunculatus, 460.
punctulatus, 458, 461.
setifer, 457, 460, 461.
tibicen, 462.
(*Aniculus*) *aniculus*, 461.
(*Calcinus*) *tibicen*, 462.
- Pagyda**, 596, 634.
amphisalis, 635.
argyræis, 635.
aurantialis, 635.
auroralis, 635.
botydalis, 635.
calida, 635.
- Pagyda**
caritalis, 636.
discolor, 635.
erythrias, 636.
exathalis, 636.
fulvistriga, 636.
lustralis, 636.
paraphragma, 636.
pæasalis, 636.
quadrilineata, 636.
rubricatalis, 635.
salvalis, 634, 635.
schaliphora, 635.
straminealis, 636.
subtessellalis, 636.
traducalis, 636.
- Palæmon**
sp., 1001, 1009.
hispidus, 1002.
lar, 1001, 1008.
marmoratus, 1009.
ornatus, 1008.
serratus, 311.
- Palæmonella**
tridentata, 1000, 1007, 1015.
- Palæmonetes**
varians, 1004.
- Palæospondylus**
gunni, 343.
- Palamedea**, 92.
- Paleopithecus**, 77.
- Palindia**
sp., 368.
- Palthis**
arcasalis, 368.
- Paludicola**
borellii, 477.
- Pamphila**
fatuellus, 416.
icteria, 415.
- Panopea**
delagoæ, 51.
- Pantala**
flavescens, 386.
- Pantograpta**
cybelealis, 717.
orsonalis, 717.
- Panulirus**
penicillatus, 1001, 1014.
- Paophila**
garnoti, 368.
immunis, 368.
obligata, 368.
- Papilio**
agatha, 399.
agathina, 407.
ajax, 80.
alcesta, 407.
antivorii, 822.
- Papilio**
asterias, 80.
bæticus, 403.
hennetti, 381, 382, 391.
brasidas, 198.
bromius, 822.
calais, 408.
cardui, 398.
cenea, 414.
clelia, 398.
columbina, 399.
constatinus, 414.
corinneus, 56, 198, 413.
creona, 412.
crephontes, 80.
dædalus, 399.
demoleus, 56, 371, 381, 382, 414, 822, 824, 827.
dryope, 400.
erinus, 56, 822.
euphranor, 199.
florella, 412.
forestan, 416.
harpax, 405.
hippocrates, 404.
ilithyia, 400.
leonidas, 56.
lycia, 400.
machaon, 80.
machaonides, 366.
merope, 414.
—, var. *dardanus*, 56, 414, 824.
missippus, 398.
nireus, 199, 414.
nyassa, 56.
ophidicephalus, 199.
philonoe, 413.
podalirius, 80.
polistratus, 56.
polycæon, 365.
polydamas, 365.
pseudonireus, 371.
similis, 824.
solandra, 397.
sylvanus, 405.
turnus, 80.
varanes, 397.
zetes, 366.
zolicaon, 80.
- Parabuthus**
pallidus, 499.
- Paradosis**
villosalis, 732.
- Paradoxurus**
typus, 153.
- Paralepis**
borealis, 563.
coregonoides, 563.
sphyræroides, 563.

- Parapontia**
subpunctata, 402.
undularis, 402.
- Parasa**
vivida, 371.
- Paratalanta**, 602.
- Parathemisto**
abyssorum, 567, 583,
 585.
- Paratilapia**
afra, 138, 142.
bleekeri, 137, 139.
bloyeti, 138, 143.
cavifrons, 137, 141.
dimidiata, 138, 145.
furcifer, 495.
intermedia, 138, 145.
leptosoma, 495.
livingstonii, 138, 145.
longiceps, 137, 138,
 146.
longirostris, 137, 140.
macrops, 495.
modesta, 138, 144.
moiffati, 137, 140.
pfefferi, 495.
polleni, 137, 138.
retrodens, 138, 142.
robusta, 137, 141.
sacra, 137, 139.
schwebischi, 138, 144.
serranus, 138, 143.
thumbergii, 146.
typus, 137, 139.
ventralis, 495.
 (Pelmatochromis) *büt-
 tikoferi*, 147.
 (—) *jentinkii*, 148.
- Parbattia**, 601.
- Pardomima**
acutalis, 719.
- Pardopsis**
punctatissima, 401.
- Paribacus**
antarcticus, 1001, 1014.
- Parnara**
detecta, 201, 912.
- Parosmodes**
icteria, 200, 415, 911.
morantii, 200.
ranolia, 200.
- Parotis**
planalis, 733.
- Paryphanta**
bisecta, 437, 444.
fimbriata, 437.
- Pasipeda**
roseiventris, 424.
satellitica, 424.
- Patissa**
sp., 441.
- Patissa**
fulvosparsa, 441.
- Pausiris**
 (Colaspidea) *arach-
 noides*, 232.
- Pavonia**
calicifera, 529, 530,
 531, 539.
clavus, 525.
cristata, 530, 531.
decussata, 530.
divaricata, 530.
frondifera, 531.
intermedia, 529, 530,
 531, 533, 539.
obtusangula, 536.
repens, 529, 531, 539.
- Pectinator**
spekei, 766.
- Pectinura**
gorgonia, 849.
- Pedetes**
caffer, 858.
- Pelecanus**, 83, 84, 85, 86,
 87, 89, 90, 91, 94,
 95, 96, 97, 98, 99.
crispus, 852.
mitratus, 902.
rufescens, 101.
- Pelias**
migratorius, 1004.
- Pelinobius**
muticus, 504.
- Pelmatochromis**
buettikoferi, 147.
congius, 147, 149.
guentheri, 147, 148,
 150.
jentinki, 147, 148.
lateralis, 147, 148.
subocellatus, 147, 150.
welwitschi, 147, 149,
 152.
- Pelobates**, 6, 103.
- Pelodytes**, 4, 5, 6, 7, 8,
 10, 11.
caucasicus, 478.
punctatus, 12.
- Pelonium**
crinitum, 322.
insulare, 322.
lineolatum, 322.
quadrisingatum, 322.
- Pentila**
amenaida, 402.
- Peosina**
numeria, 368.
- Perichæta**
amazonica, 447.
barbadensis, 447.
capensis, 447.
- Perichæta**
cresecentica, 445, 447,
 448.
cupulifera, 445, 446.
houlleti, 449.
morrissi, 446.
peguana, 449.
- Periclimenes**
danæ, 1000, 1004,
 1015.
grandis, 1006.
petitthouarsi, 1006.
rotumanus, 1001, 1005,
 1015.
spinigerus, 1001, 1004.
vitiensis, 1001, 1005,
 1006, 1015.
- Peridinium**
divergens, 1029.
- Perigea**
circuta, 368.
- Periophthalmus**
koelreuteri, 3, 587.
- Periplaneta**
americana, 932, 933,
 935, 937, 938, 939,
 946, 947, 348, 957.
australasie, 933, 937,
 938.
orientalis, 932, 933,
 934, 936, 937, 938,
 939, 949, 957.
- Perissodus**, gen. nov., 496.
microlepis, 496.
- Petalognathus**
nebulata, 116.
- Petrocephalus**, 780, 787.
affinis, 799.
balayi, 787, 789.
bane, 777, 787, 788.
bovei, 787, 789.
catostoma, 787, 790.
de joannis, 788.
dequesne, 788.
ehrenbergii, 788.
gliroides, 787, 790.
isidori, 798.
marchei, 792.
pictus, 803.
sauvagii, 787, 788.
simus, 787, 789.
- Petrochromis**, gen. nov.,
 496.
polyodon, 496.
- Petrolisthes**
armatus, 464, 465.
asiaticus, 464, 465,
 466.
bellis, 466.
dentatus, 465, 466,
 467.

Petrolisthes

- dentatus*, var., 465.
gundlachii, 465.
haswelli, 464, 466.
lamarcki, 457, 458,
 464, 465, 466, 467,
 468.
 —, var. *asiaticus*,
 457, 458, 464, 465,
 466, 467, 468.
 —, var. *fimbriatus*,
 457, 458, 466, 467,
 468.
 —, var. *rufescens*,
 457, 458, 465, 466,
 467.
leporina, 465.
leporinoides, 465.
marginatus, 465, 466.
rufescens, 466.
speciosus, 464, 465,
 466.

Petrophassa

- albipennis*, 353, 354.
rufipennis, 354.

Pettigramma

- spiculata*, 439.

Phacellura

- adventalis*, 738.

Phaenna

- spinifera*, 543, 548.

- Phaëthon*, 82, 83, 84, 85,
 86, 87, 89, 90, 91,
 93, 94, 95, 96, 97, 98,
 99, 100, 101.
flavivestris, 87, 89, 90,
 100, 101.

Phagrus

- dorsalis*, 819.

Phakellura

- abruptalis*, 747.
curcubitalis, 738.
fuscicollis, 747.
gazorialis, 738.
gigantalis, 737.
grisealis, 747.
guenealis, 737.
immaculalis, 737.
infernalis, 747.
marianalis, 735.
peridromella, 442, 739.
plumbidorsalis, 737.
subauralis, 747.
zygænalis, 738.

- Phalacrocorax*, 83, 84, 85,
 86, 89, 90, 91, 93,
 94, 95, 96, 97, 98,
 99.

bicristatus, 100.

- carbo*, 83, 84, 88, 90,
 100, 101.

Phalæna

- angustalis*, 623.
cribrata, 442.
erosalis, 630.
marginata, 747.
perspectata, 754.
phenice, 443.
recurvalis, 623.
sinuata, 443.
socialis, 666.
splendidalis, 642.
stygialis, 669.
vallantina, 429.
 (Noctua) *archesia*, 424.
 (—) *fluctuosa*, 421.
 (—) *hippasia*, 423.
 (—) *latona*, 421.
 (—) *materna*, 424.

Phalanger

- maculatus*, 246.

Phalangiodes

- rivulalis*, 753.

Phasis

- thero*, 908.

Phelsuma

- breviceps*, 914.

Pheмиades

- utha*, 367.

Phialidium

- sp., 1030.

Philodromus

- alpestris*, 488.

Phlyctænodes

- 602.

Phocides

- pyres*, 366.

Pholidobolus

- montium*, 114.

Phoneutria

- auricularis*, 15, 19.
capulina, 15.
debilis, 15, 20.
decora, 15, 18.
erythrochelis, 15, 18.
fasciata, 15.
marshalli, 19.
melanogastra, 15, 19, 26.

Phoneyusa

- bettoni*, 503, 504.
gregorii, 503, 504.

Phostria

- confluentalis*, 679.

Photinus

- blandus*, 319, 320.
decipiens, 320.
elongatus, 320.
interruptus, 320.
limbipennis, 320.
littoralis, 320.
minutus, 319.
notatus, 319, 333.
pallens, 320.

Photinus

- parvulus*, 320.
quadrimaculatus, 320.
rufus, 320.
vittatus, 320.
vittiger, 320.

Photuris

- brunnipennis*, 320.

Phrissura

- lasti*, 412.

Phryctena

- glaucoptidalis*, 671.

Phryganodes

- 597, 677.
abnormalis, 671.
albipedalis, 686.
albirenalis, 682.
analis, 684.
apicalis, 685.
attenuata, 680.
basalticalis, 678.
biguttata, 681, 761.
caniusalis, 686.
capillalis, 683.
centralbalis, 681, 761.
concolor, 683.
crithonalis, 684.
croceiceps, 685.
cuniculalis, 684.
dariusalis, 685.
delilalis, 685.
diffusimarginalis, 680.
dispilotalis, 685.
erebusalis, 678.
euagra, 685.
eucharisalis, 682.
flocculentalis, 680, 761.
fulvicauda, 684.
glyphodalis, 685.
hamiferalis, 684.
hesusalis, 682.
humeralis, 684.
imbecilis, 686.
insolutalis, 684.
lanialis, 681, 761.
lithosialis, 679.
longipennis, 679.
lophophoralis, 683.
maculicostalis, 685.
margarita, 680.
martyralis, 686.
nilvalis, 679.
mimastis, 685.
nicocalis, 680.
noctescens, 677, 683.
nubilis, 678.
obscurata, 678.
ochrosoma, 684.
odontosticta, 685.
omphalobasis, 683, 761.
origoalis, 679.
pachycraspedalis, 683.

- Phryganodes**
palliventralis, 684.
perfulvalis, 679, 761.
persiusalis, 679.
piasusalis, 684.
plicatalis, 682.
productalis, 678.
prolongalis, 369, 678.
purpuralis, 682.
quadriguttata, 685.
radicalis, 678.
regalis, 681.
rutilalis, 683.
schediusalis, 686.
setifera, 682.
simialis, 685.
similis, 369.
tagiadalis, 686.
tedea, 679.
temira, 679.
tetraplagalis, 681.
unitalis, 685.
unitinctalis, 686.
variatis, 679.
xipharesalis, 683.
- Phrynixalus**
oxyrhinus, 476, 480, 482.
- Phrynobatrachus**
perpalmatus, 474, 479, 482.
- Phrynocephalus**
euptilopus, 915.
- Phrynosoma**
frontale, 915.
- Phycidicera**
manicalis, 708.
salebrialis, 708.
- Phyllobates**
infraguttatus, 118, 126, 476.
- Phyllodactylus**
elisæ, 913.
siamensis, 913, 918, 923.
unctus, 913.
- Phyllodromia**
 sp., 384.
germanica, 384.
- Phyllodromus**
pulchellus, 119.
- Phyllorhina**, 75.
- Phyllotis**
griseostavus, 210.
- Phymosoma**, 468.
- Physcænura**
leda, 397.
pione, 50.
- Physcosoma**
dentigerum, 471.
microdontoton, 471, 473.
- Physcosoma**
nigrescens, 470.
pacificum, 470, 473.
scolops, 470.
varians, 468, 471.
- Physematia**
pollutalis, 616.
rotundalis, 727.
- Physophora**
hydrostatica, 545.
- Pieris**
albusta, 365.
gidica, 370, 412.
infida, 370.
lordaca, 412.
omphale, 410.
thysa, 412.
- Piletosoma**, gen. nov., 595, 707.
ignedorsalis, 708, 761.
novalis, 707.
- Pilocrocis**, 597, 655.
acutangula, 659.
anigrusalis, 657.
anormalis, 658.
barcalis, 657.
calamistis, 657.
chlorisalis, 659.
collustralis, 660.
confixalis, 659.
coptobasis, 656.
cryptalis, 658.
cyrisalis, 658.
damonalis, 658.
delimitalis, 655.
discodontalis, 658.
dryalis, 657.
gilippusalis, 658.
imbrexalis, 655.
infuscalis, 369, 658.
inguinalis, 657.
latifuscalis, 659.
lauralis, 655.
leucoplagal, 658, 761.
liberalis, 658.
maceralis, 659.
melanoproctis, 659.
plumbicostalis, 655.
purpurascens, 656.
ramentalis, 655, 656.
roxonalis, 658.
symomotis, 656.
tripunctata, 655.
tristigmatis, 659.
xanthyalinalis, 657.
xiphialis, 657.
- Pinacia**
ocularis, 640.
- Pinacopteryx**
liliana, 413.
- Pinacopteryx**
pigea, 198.
- Pionea**, 601.
comalis, 759.
incomalis, 759.
- Pipa**, 4, 8, 10, 12.
- Pipistrellus**
abramus, 771.
savii pulveratus, 771.
- Pirata**
latitans, 488.
- Pisenor**
höhneli, 498, 505.
nigellus, 505.
- Pisenorodes**, gen. nov., 504.
höhneli, 505, 506, 524.
- Pisidia**
asiatica, 464.
lamarekii, 464.
- Pitama**
lativitta, 739.
- Pitthea**
trifasciata, 419.
- Planema**
jacksoni, 400.
montana, 400.
- Platamonia**
binotalis, 699.
- Plateros**
ferreranus, 317.
fraternus, 317.
palliat, 317.
- Platylesches**
moritili, 912.
- Platystoma**
juruen, 44.
- Platytes**
pusillalis, 369.
- Plecodus**, gen. nov., 497.
paradoxus, 497.
- Plecotus**, 61.
- Plectrona**
dohrnii, 686.
- Pleonectusa**
planalis, 693.
- Plesiocercis**, 533.
australie, 534.
- Pletholax**
gracilis, 914.
- Pleurodeles**
watlii, 106.
- Pleuromma**
abdominale, 543, 546, 547, 549, 579.
- Pleuromectes**
platessoides, 310.
- Pleuroptya**
fuscalis, 719.
- Plœtsia**
cerymica, 827.

- Plotus, 83, 84, 85, 86, 90,
 91, 93, 94, 95, 96, 97,
 98, 99.
 anhinga, 84.
 Plusia
 eriosoma, 424.
 Pocillopora
 suffruticosa, 267.
 Podabacia, 527.
 Pœcilocerus
 sokotranus, 384, 391.
 Pœcilogale
 albinucha, 1.
 Pœcilomorpha
 hirsuta, 216, 242.
 tomentosa, 216.
 Pœcilotheria
 striata, 81.
 Poltys
 corticoides, 513, 524.
 illepoides, 514.
 monstrosus, 514.
 Polycaon
 excusus, 328.
 Polychrus
 gutturosus, 114.
 Polycorus
 seminigras, 713.
 Polydesma
 umbricola, 421.
 Polygrammodes, 601.
 Polyonmatus
 amarah, 405.
 beticus, 54, 192, 403.
 jesous, 404.
 Polyphyllia, 529.
 Polypterus
 lapradii, 493.
 palmas, 493.
 Polyptychus
 grayi, 432.
 Polythlipta, 598, 752.
 annulifera, 753.
 caradrinalis, 684.
 cerealis, 752.
 columalis, 753.
 distorta, 753.
 divaricata, 752.
 euroalis, 753.
 globulipedalis, 753.
 inconspicua, 753.
 liquidalis, 752.
 macralis, 753.
 nodiferalis, 753.
 ossealis, 752.
 peragrata, 753.
 splendidalis, 641.
 vagalalis, 752.
 Pontia
 eris, 408.
 evarne, 409.
 Pontia
 protomedia, 412.
 Pontonia
 meleagrinea, 1007.
 Porites
 alveolata, 268, 276.
 arenacea, 272.
 arenosa, 267, 272, 274,
 276.
 —, var. *lutea*, 273, 274,
 276.
 —, var. *parvicellata*,
 274, 276.
 columnaris, 270.
 conglomerata, 274.
 —, var. *lutea*, 273.
 cribripora, 276.
 echinulata, 276.
 exilis, 275, 276.
 favosa, 276.
 gaimardi, 276.
 lichen, 276.
 lutea, 273.
 parvistellata, 272, 274,
 276.
 purpurea, 269, 271,
 276.
 superfusa, 274, 276.
 tenuis, 276.
 trimurata, 270, 271,
 272, 276.
 umbellifera, 271, 276.
 viridis, 268, 271, 276.
 —, var. *apalata*, 268,
 276.
 Prænesta
 fabialis, 648.
 Precis
 guruana, 397.
 natalica, 398.
 sesamus, 370.
 taveta, 370, 397.
 Priotoma
 brevis, 327.
 Pristes
 tuberosus, 955.
 Pristurus
 collaris, 913.
 percristatus, 913.
 phillipsii, 913.
 Problepsis
 vestalis, 435.
 Procavia
 brucei somalica, 766.
 Procellana
 armata, 464.
 asiatica, 464.
 bellis, 464.
 dentata, 464, 465.
 gundlachi, 464.
 leporina, 464.
 Procellana
 rufescens, 465.
 speciosa, 464.
 (Petrolisthes) *dentata*,
 464.
 (—) *rufescens*, 465.
 Prochoristis, 601.
 Proconica, gen. nov., 598,
 686.
 flaviguttalis, 687.
 nigrocyanalis, 687.
 Proctoporus
 unicolor, 114.
 Procyon
 cancrivorus, 154, 160,
 163, 165, 166, 167,
 185.
 lotor, 154, 157, 158,
 159, 160, 162, 163,
 164, 165, 167, 169,
 171, 185.
 Proœdema, 602.
 Prorodes, 597, 711.
 mimica, 711.
 Prostherapis
 femorialis, 118.
 Prothesima
 latreillii, 488.
 nigrita, 488.
 Proteides
 idas, 366.
 Proteles
 cristatus, 153, 183.
 lalandii, 185.
 Protocolletis, 599.
 Protogoniomorpha
 aglatonice, 52, 398.
 —, var. *aglatonice*, 52.
 —, var. *nebulosa*, 52.
 anacardii, 52.
 definita, 398.
 nebulosa, 398.
 Protoparce
 convoluti, 432.
 Protopterus, 41.
 Protosquilla
 cerebralis, 33, 38.
 trispinosa, 33, 34, 38.
 Protrigonia, 599.
 Psalmodæus
 cambridgii, 891, 892,
 896, 899, 900.
 Psammocora
 contigua, 536.
 gonagra, 536.
 haimiana, 533, 534,
 535, 536, 537, 539.
 monile, 539.
 obtusangula, 533, 534,
 535, 536.
 plicata, 536.

- Psammocora**
profundacella, 534, 535, 537, 539.
savigniensis, 534, 535, 538, 539.
superficialis, 534, 535, 537, 539.
- Psephis**, 594, 605.
myrmidonalis, 605, 606.
- Psephotus**
chrysopterygius, 356.
dissimilis, 356.
- Pseudedusia**, gen. nov., 229.
fulvipes, 229.
- Pseudidiops**
hartii, 892.
- Pseudivongius**
æneus, 228.
natalensis, 228.
- Pseudobuthus**
dentatus, 498, 499, 500.
- Pseudocalanus**
clongatus, 542, 547.
- Pseudochina**
serricornis, 326.
- Pseudochoreutis**
chorcutalis, 614.
- Pseudocolaspis**
costata, 230, 242.
cupreo-marginata, 230.
discoidalis, 231.
lateralis, 230, 231.
laticollis, 231.
- Pseudocucumis**
acicula, 843, 844.
africana, 835, 843, 844, 845, 848.
intercedens, 843, 844.
japonica, 844, 845.
mixta, 843.
thieli, 843, 845.
- Pseudomalegia**
fulvipes, 227.
lfevrei, 227.
- Pseudonympha**
cassius, 188.
sabacus, 188.
trimeni, 903.
vigilans, 188.
- Pseudosquilla**
ciliata, 33, 36.
oculata, 37.
ornata, 37.
oxyrhyncha, 33, 37, 38.
stylifera, 36.
- Pseudotantalus**, 85.
- Psyllobora**
lineola, 339.
nana, 339.
punctella, 339.
- Pterinochilus**
murinus, 501.
nigrofulvus, 503.
spinifer, 502, 503, 524.
vorax, 502, 503.
- Pteropus**
edulis, 65, 67, 68, 70, 73.
edwardsi, 76.
medius, 58, 60, 61, 63, 64, 66, 69.
poliocephalus, 59.
rodericensis, 58.
- Pterygius**
appialis, 701.
calligraphalis, 704.
- Pterygospidea**
djelæle, 415.
- Ptilopus**
cinctus, 354.
 (Leucotreron) *alligator*, 354.
- Ptinus**
serricornis, 326.
tessellatus, 324, 333.
- Putorius**
communis, 185.
- Pycnarmon**
caberalis, 619.
cribrata, 442.
- Pygomeles**
braconnieri, 918.
trivittatus, 918.
- Pygoscelis**
adeliez, 960, 961, 964, 983, 986.
antarctica, 965, 983.
papua, 960, 961, 964, 967, 970, 977, 979, 983, 986, 988, 989.
taniata, 961, 984.
- Pygospila**, 598, 749.
bivitalis, 750.
costiflexalis, 749, 750.
cuprealis, 750.
evanidalis, 750.
octomaculalis, 750.
tyres, 750.
- Pyralis**
aonialis, 637.
deciusalis, 637.
gryllusalis, 723.
incertalis, 699.
lucernalis, 738.
marginalis, 738.
ornatalis, 630.
perfusalis, 612.
polita, 734.
subtrigonalis, 760.
verticalis, 721.
- Pyrameis**
abyssinica, 822.
cardui, 52, 379, 398, 824.
- Pyrausta**, 602.
absistalis, 699.
phœnicealis, 368.
platycapna, 653.
- Pyrgoma**
millepora, 251, 831.
- Pyrgus**
asterodia, 415.
asychis, 415.
bettoni, 415, 444.
diomus, 911.
dromus, 415, 911.
mafa, 199.
sataspes, 911.
spio, 199, 911.
vindex, 371.
zebra, 415.
- Pyrophacus**
horologium, 1029.
- Pyropyga**
minuta, 319.
- Python**
reticulatus, 587.
- Rabdosoma**
badium, var. *multicinctum*, 116.
- Raia**
fullonica, 310.
- Rana**, 7, 11.
alticola, 555.
fusca, 101.
florensis, 474.
hascheana, 474.
leitensis, 474.
luzonensis, 474.
macrops, 474.
microdisca, 474.
newtoni, 474.
nutti, 474.
ornata, 474.
palustris, 9.
pulchra, 474.
temporaria, 101.
- Rangifer**
tarandus, 456.
terre-novæ, 456.
- Raporna**
limbata, 426.
- Raphiceros**
sharpei, 391.
- Rappia**
molleri, 475.
quinquevittata, 475.
rutenbergii, 475.
thomensis, 475.
tristis, 475.

- Ravanoa**, 594, 621.
strigulosa, 692.
xiphialis, 622.
- Redoa**
crociipes, 427.
- Regalecus**
argenteus, 380.
- Rehimena**, 594, 622.
dichromalis, 622.
divisa, 623.
pallidalis, 693.
phrynealis, 622.
striolalis, 622, 623.
- Remigia**
archesia, 424.
repanda, 368, 424.
- Remipes**
adactylus, 467.
pacificus, 457, 458,
 467, 468.
testudinarius, 467,
 468.
- Renodes**
nigriceps, 424.
- Rhabdryas**
trite, 365.
- Rhacophorus**
brachychir, 475.
fasciatus, 475.
hosii, 475.
macroscelus, 475.
majori, 475.
moquardi, 475.
monticola, 475.
nigropalmatus, 475.
peracca, 475.
- Rhagoba**
bimaculata, 750.
- Rhagodes**
ornatus, 520.
- Rhaphiderus**
scabrosus, 943, 954.
- Rhax**
ornatus, 520.
- Rhectosomia**, 602.
- Rhembastus**
kraatzi, 237.
punctato-sulcatus, 238.
recticollis, 237.
viridis, 238.
- Rhimphalea**, 596, 640.
astrigalis, 640, 761.
circotoma, 641.
fastidialis, 641.
heranialis, 641.
lindusalis, 641.
ochalis, 640.
anone, 641.
papualis, 641.
scelatalis, 641.
trogusalis, 640.
- Rhimphaleodes**, 595, 618.
macrostigma, 618.
- Rhina**
squatina, 296.
- Rhincalanus**
cornutus, 542, 549.
gigas, 542.
- Rhinolophus**
antinorii, 761.
collongensis, 75.
ferrum-equinum, 77.
hipposideros, 62, 78.
luctus, 770, 771.
lugdunensis, 75.
pearsoni, 770.
schlosseri, 76.
- Rhizomys**
sinensis, 775.
- Rhizopertha**
bifoveata, 329, 333.
- Rhizotrochus**
levidensis, 995.
- Rhodaria**
olivacealis, 630.
- Rhopalocampta**
anchises, 371, 382.
forestan, 416.
jucunda, 382.
keithloa, 382, 827.
pisistratus, 57, 912.
taranis, 382.
- Rhoptrurus**
dentatus, 499.
- Rhymbus**
apicalis, 338.
globosus, 337, 338.
minutus, 338.
unicolor, 338.
- Rhynchina**
antiqualis, 426.
phisioides, 426.
laruensis, 426.
- Rhynchocyon**
cirnei, 392.
- Rhythemis**
semihyalina, 386.
- Risoba**
obstructa, 425.
- Sabalia**
picarina, 432.
- Sagariphora**
heliocæna, 628.
- Sagitta**
whartoni, 578.
- Salagena**
transversa, 439.
- Salamis**
nebulosa, 398.
- Salassina**
formosa, 513.
- Salbia**
abnormalis, 643.
dilutalis, 644.
pellucidalis, 644.
præformatalis, 646.
squamosalis, 644.
- Salbiomorpha**, 595, 654.
torsalis, 654, 655.
- Samanta**
perspicua, 50, 396.
 —, var. *simonsi*, 187.
simonsi, 50.
- Samea**, 597, 647.
acstealis, 703.
castellalis, 647.
ceanothi, 80.
cecropia, 80.
chlorophasma, 636.
conjunctalis, 647.
cuprinalis, 652.
dignotalis, 653.
discessalis, 647.
disertalis, 647.
ecclesiialis, 647.
figuralis, 647.
fumidalis, 647.
irruptalis, 694.
isaralis, 647.
jarbusalis, 636.
lucussalis, 647.
medealis, 703.
melicertalis, 646.
multiplicalis, 647.
nicæusalis, 647.
quinquigera, 723.
usitata, 653.
yerburyi, 729.
- Sameodes**, 603.
cancellalis, 369.
- Santaremia**
longipes, 891, 896, 898.
- Sapæa**
paradisea, 199, 201.
trimeni, 199.
- Sarangesa**
djælele, 415.
eliminata, 414, 415,
 911.
motozi, 414, 415, 911.
motozioides, 414, 911.
pertusa, 371, 414, 415,
 911.
 —, var., 415.
synestalmenus, 414, 911.
- Sarcophaga**
 sp., 387.
carnaria, 957.
- Saron**
gibberosus, 1009, 1010.
marmoratus, 1000,
 1001, 1009, 1012.

- Sarsia**
 sp., 1023, 1030.
gemmipara, 1030.
- Sathria**
stercoralis, 723.
- Saturnia**
kuntzei, 431.
wallengreni, 429.
- Saurothera**, 48.
- Scaptira**
aporoceles, 916.
- Sceliodonta**
inæqualis, 228.
pectoralis, 228.
raffrayi, 228.
- Sceloporus**
asper, 915.
cupreus, 915.
dugei, 915.
lickii, 915.
utiformis, 915.
zosteromus, 915.
- Scelotes**
gronovii, 918.
occidentalis, 918.
- Schœnobius**
chrysostomus, 441.
- Scincus**
hemprichii, 918.
- Sciurus**
ferrugineus, 245.
finlaysoni, 245, 246.
macclellandii swinhoei,
 771.
mutabilis, 392.
- Scodra**
calceata, 81.
- Scolitantides**
bowkeri, 194.
thespis, 194.
- Scolopendra**
gigas, 587.
- Scoparia**
alconalis, 760.
quietalis, 713.
- Scopelus**
glacialis, 279, 550,
 552, 553, 554, 557,
 558, 559, 560, 566.
mülleri, 553.
scoticus, 553, 558, 560.
- Scopula**
criasusalis, 760.
optatusalis, 760.
stipatalis, 607.
- Scorpæna**
dactyloptera, 550, 551.
- Scorpio**
bellicosus, 498.
gregorii, 498.
- Scorpio**
pallidus, 499.
- Scotinochroa**
inconsequens, 436.
- Scotophilus**
ornatus, 771.
pallidus, 78.
- Scrophicephalus**
kanume, 818.
- Scybalista**, 594, 608.
acutalis, 609.
bifascialis, 608, 609.
canalis, 609.
leucolepia, 608.
prusalis, 609.
restionalis, 609.
semiferrealis, 609.
subductalis, 609.
trifunalis, 606.
- Scymnus**
grenadensis, 342.
högei, 342.
ochroderus, 341.
phlæus, 343.
roseicollis, 342.
thoracicus, 341, 342.
- Scythrops**
novæ-hollandiæ, 41–49.
- Sebastes**
marinus, 550.
norvegicus, 550, 551.
- Secusio**
parvipuncta, 371.
strigata, 419.
- Selenops**
diversus, 390, 391.
dufourii, 390, 391.
madagascariensis,
 391.
- Senex**
penicillatus, 1014.
- Sepsina**
ornaticeps, 918.
- Serrasalmo**
serrulatus, 492.
- Sestia**
deosalis, 747.
- Setina**
quadrinotata, 419.
- Siderastræa**
clavus, 525, 539.
- Siderina**, 525.
- Silis**
pauzilla, 322.
tenella, 321.
- Simæthistis**, 604.
- Simochromis**, gen. nov.,
 496.
diagramma, 496.
- Simplicia**
inflexalis, 427.
- Sinoxylon**
sex-tuberculatum, 329.
- Siphonops**
brasiliensis, 479.
- Siphonosphæra**
tizardi, 1022, 1025, 1032.
- Sipunculus**
cumanensis, 469.
edulis, 469.
funafuti, 470, 473.
rotumanus, 469, 473.
vastus, 469, 473.
- Sithon**
antalus, 407.
- Smerinthus**
excæcatus, 80.
grayi, 432.
nyops, 80, 81.
ocellatus, 80.
- Solmaris**
 sp., 1023, 1030.
- Solmundella**
 sp., 1023, 1030.
- Solpuga**
brunnipes, 520.
merope, 520.
semifusca, 520.
sericca, 520, 521.
zebrina, 520, 521.
- Sommeria**
culta, 429.
- Spadella**
 (Krohnia) *hamata*, 544.
- Spanista**
pretiosalis, 637.
- Sparagmia**, 600.
- Sparassus**
bicorniger, 519, 524.
- Sparus**
chromis, 132.
niloticus, 132.
- Spelerpes**
altamazonicus, 479.
bocourti, 478.
subpalmatus, 478.
- Sphærodactylus**
homolepis, 914.
- Spheniscus**
demersus, 960, 961,
 985, 986.
humboldti, 900, 981.
magellanicus, 959, 960,
 961, 977, 983, 985,
 986, 988.
mendiculus, 981.
- Sphenodon**
punctatus, 589.
- Sphenophryne**
anthonyi, 476.
ateles, 476.
hiroï, 476.

- Sphenophryne**
cornuta, 476.
loriæ, 476.
monticola, 476.
variabilis, 476.
verrucosa, 476.
- Sphindus**
americanus, 328.
dubius, 328.
- Sphingomorpha**
monteironis, 422.
- Sphinx**
carolina, 80.
convolvuli, 432.
demolinii, 432.
ligustri, 80.
lucitiosa, 80, 81.
- Spilomela**, 597, 669.
fimbriauralis, 669.
ommatalis, 640.
perspicata, 669.
retinalis, 636.
strabonalis, 640.
- Spilotes**
megalolepis, 115.
- Spindasis**
caffer, 195, 196.
ella, 195, 196, 201.
homeyeri, 195, 196.
masilikazi, 195, 201.
namaquus, 372.
natalensis, 196.
somalina, 370.
waggæ, 370, 372.
- Spoladea**
animalis, 623.
avuncularis, 624.
exportalis, 623.
spilotalis, 624.
- Squilla**
chiragra, 34.
ciliata, 36.
maculata, 37.
multituberculata, 33, 38.
polita, 38.
quadridens, 38.
scyllarus, 36.
stylifera, 36.
- Stauropus**
dasychiroides, 433, 444.
- Steatomys**
pratensis, 393.
- Stegodyphus**
africanus, 517.
bettoni, 517.
lineifrons, 516, 517, 524.
mimosarum, 517.
- Stenia**
præstrictalis, 605.
- Stenocercus**
roseiventris, 915.
- Stenodactylus**
petrii, 913.
- Stenoptycha**, 604.
- Stenopus**
hispidus, 1001, 1002,
 1015.
- Stenurges**
floridalis, 730.
- Sternarchus**
tamandua, 44.
- Sterranthia**
sacraria, 371.
- Stichoplastus**
sanguiniceps, 892, 895.
- Stilpnotia**
crocipes, 371.
- Stomatorhinus**, 780, 799.
microps, 777, 800.
walkeri, 799.
- Stomias**
ferox, 564.
- Strepsiceros**
imberbis, 586, 768.
strepsiceros, 768.
- Stugeta**
bowkeri, 54.
- Stylophora**
compressa, 997, 1000.
digitata, 996, 997.
flabellata, 996.
lobata, 999, 1000.
palmata, 999, 1000.
pistillata, 998.
rugosa, 998, 1000.
septata, 996, 1000.
- Sudis**
atlanticus, 563.
- Sufetula**, 594, 613.
diminutalis, 614.
hemiophthalmia, 614.
macropalpa, 613.
rectifascialis, 614.
sunidesalis, 613, 614.
- Sula**, 83, 85, 86, 89, 90,
 91, 93, 94, 95, 96,
 97, 98, 99.
leucogastra, 101.
- Syagrus**
calcaratus, 237.
corrosicollis, 236.
marshalli, 236.
mashonanus, 236.
- Sylepta**, 595, 712.
abyssalis, 718.
acætesalis, 717.
adductalis, 714.
æchmisalis, 722.
albipunctata, 724.
amando, 722.
amissalis, 723.
angulifera, 721.
- Sylepta**
angustalis, 720.
arctalis, 714.
aurantiacalis, 718.
balteata, 718.
belialis, 721.
bipartalis, 720.
bipunctalis, 720.
carbatinalis, 713.
cephalis, 721.
ceresalis, 716.
chalybifascia, 719.
chromalis, 715.
citrinalis, 722.
clementsii, 716, 761.
cælivitta, 725.
cohæsalis, 713.
cometa, 719.
concatenalis, 716.
contiguialis, 714.
costalis, 720.
crotonalis, 713.
curiusalis, 713.
cyanea, 725.
deficiens, 724.
denticulata, 713.
derogata, 722.
diophtalis, 725.
dissipatalis, 723.
elathealis, 723.
elevata, 369, 722.
expansalis, 717.
fabiussalis, 717.
fraterna, 714.
fuscomarginalis, 722.
gastralis, 720.
gordialis, 713.
gorgonalis, 717.
hecalialis, 369, 722.
hecitalis, 713.
homomorpha, 722.
hyalescens, 719.
idmonalis, 717.
inferior, 724.
insignis, 719.
internitalis, 369, 723.
iopasalis, 722.
iophanes, 722.
lactiguttalis, 715.
laticalis, 720.
leucodontia, 713.
limata, 717.
luctuosalis, 715.
lunalis, 714.
machinalis, 724.
maculalis, 718.
magna, 723.
matutinalis, 723.
megastigmatis, 723.
mesoleucalis, 724.
mnemusalis, 720.

- Sylepta**
multilinealis, 722.
mysissalis, 722.
nasonalis, 724.
nigriflava, 722.
nigriscriptalis, 725.
ningpooalis, 716.
obliquifascialis, 715.
obscuralis, 722.
ochrifusalis, 721.
ochrotozona, 724.
ogooalis, 723.
onophasalis, 723.
orbiferalis, 715.
ovialis, 715.
pactolalis, 723.
patagialis, 716.
paucistrialis, 718.
pellucida, 717.
penumbralis, 721.
pernitescens, 719.
phileatalis, 720.
picalis, 719, 761.
plumifera, 712, 761.
pogonodes, 718.
polydonta, 721.
pronaxalis, 719.
prumnides, 723.
purpuralis, 723.
purpurascens, 714.
pyranthes, 715.
quadrinaculalis, 724.
reginalis, 718.
rhyparialis, 722.
ridopalis, 714.
ruralis, 721.
sabinusalis, 721.
sarronalis, 715.
scinisalis, 720.
scopulalis, 713.
scripturalis, 717.
secta, 717.
segnalis, 715.
sellalis, 712, 720.
silicalis, 720.
simmialis, 723.
solilucis, 719, 761.
straminea, 722.
striginervalis, 721.
subalbidalis, 723.
textalis, 714.
tibialis, 717.
torsipez, 715, 761.
tricolor, 715.
ultimalis, 722.
venustalis, 722.
verecunda, 720.
- Syllepsis**, 598, 754.
marialis, 754, 755.
- Symbranchus**
marmoratus, 492.
- Symphysa**, gen. nov., 594, 609.
amœnalis, 610.
cripalis, 610.
sulphuralis, 609, 610.
- Synapta**
godeffroyi, 835, 847.
kefersteini, 835, 847, 848.
ooplax, 835, 848.
- Synchloe**
anomala, 380.
glauconome, 371.
- Synclera**
fenestralis, 651.
nemoralis, 664.
- Syngamia**, 596, 643.
abjungalis, 645.
abruptalis, 442, 645.
ampliatalis, 646.
ancidalis, 644.
aquaticalis, 646.
camillusalis, 646.
cassidalis, 644.
cognatalis, 644.
deformalis, 644.
dentilinealis, 645, 761.
falsidicalis, 645.
fervidalis, 645.
flabellalis, 643.
florella, 644.
floridalis, 643, 644.
hæmorrhoidalis, 645.
latifusalis, 646.
latimariginalis, 645.
marmorata, 646.
merioncalis, 644.
octavialis, 644.
pepitalis, 644.
rubrocinctalis, 644.
secutalis, 644.
tiphalis, 644.
tytiusalis, 646.
vibiusalis, 645.
violata, 645.
violoscentalis, 646.
xanthalis, 644.
- Synodontis**
multipunctatus, 497.
- Synophis**
bicolor, 115.
miops, 115, 126.
- Syrrhopus**
areolatus, 122, 126, 477.
- Tabidia**, 594, 624.
aculealis, 624.
candidalis, 624.
craterodes, 624.
insanalis, 624.
truncatalis, 624, 761.
- Tachyoryctes**
splendens, 766.
- Tæniopyga**
sylvina, 58.
- Tagiades**
fesus, 56.
- Talanga**
delectalis, 743.
- Talpa**
wogura, 771.
- Taphozous**, 58, 77.
mauritianus, 77.
- Tapinauchenius**
plumipes, 891, 898.
sancti-vincenti, 898.
- Tarache**
 sp., 421.
admota, 421.
ardoris, 420.
porphyrea, 420.
tropica, 420.
upsilon, 420.
- Tarentula**
andrenivora, 488.
nemoralis, 488.
pulverulenta, 488.
- Tarsocera**, gen. nov., 903.
cassina, 903.
- Tarucus**
cassius, 364.
louisæ, 370, 371.
monops, 364.
plinius, 54, 404, 826.
sybaris, 372, 907.
theophrastus, 370, 372, 380, 907.
- Tatura**
mimosa, 370.
philippus, 370.
- Tegostoma**, 602.
- Telchinia**
perrupta, 400.
- Telea**
polyphemus, 80.
promethea, 80.
- Telegonus**
alardus, 366.
christyi, 366.
habana, 366.
- Telephorus**
præustus, 321.
- Telmatochromis**, gen.
 nov., 495.
temporalis, 495.
vittatus, 495.
- Temora**
longicornis, 543, 546, 547, 549, 578, 580.
- Tercolus**
abyssinicus, 408.
achine, 910.

Teracolus

- achine*, var. *simplex*, 198.
aldabrensis, 381.
anax, 55.
annæ, 187, 198.
antevippe, 198, 410.
 —, var. *subvenosus*, 410.
antigone, 910.
arne, 370.
aurigineus, 411.
bettoni, 409.
calais, 370, 408.
callidia, 198, 825, 827.
candidus, 380, 381.
catochrysops, 411, 827.
chrysonome, 370.
citreus, 406.
caelestis, 411.
daira, 910.
dissociatus, 826.
eris, 408.
eupompe, 370.
evagore, 370.
 — *phlegetonia*, 910.
evarne, 370, 409, 827.
evenina, 370.
exole, 198, 410.
 —, var. *roxane*, 410.
gavisa, 198, 410.
halimede, 411.
heliocautus, 370.
helvolus, 411.
 —, var., 411.
hero, 910.
hetæra, 395, 408.
heuglini, 409.
hildebrandti, 198.
hyperides, 910.
ignifer, 370, 910.
imperator, 408, 409, 825, 826.
incretus, 409.
infumatus, 187.
ione, 55.
isaura, 198.
ithonus, 55, 910.
 —, var. *ignifer*, 55.
jacksoni, 409.
johnstoni, 909.
leo, 395, 411.
lorti, 371.
mutans, 55, 412.
niveus, 380, 381.
omphale, 55, 370, 410, 825, 902, 910, 911.
pallene, 187, 902, 910, 911.
phillipsi, 370, 822.
phlegetonia, 903, 910.

Teracolus

- phlegyas*, 409, 909.
protomedia, 371, 412, 822, 827.
pseudacaste, 370, 410.
puniceus, 395, 408.
regina, 55.
sipylus, 55.
syrtinus, 409, 827.
thruppi, 370, 409.
trimeni, 198.
venata, 395.
venosus, 411.
wallengrenii, 198.
xanthus, 410, 827.
- Teras
 sp., 383.
- Terastia, 601.
- Terias
æthiopica, 197, 909.
bisinuata, 909.
briggita, 197, 909.
 —, var. *zoe*, 55, 407.
butleri, 197, 909.
ceres, 370.
floricola, 909.
hapale, 909.
 —, var. *æthiopica*, 55, 197.
marshalli, 55, 197.
orientis, 197.
senegalensis, 197, 408, 909.
 —, var. *bisinuata*, 408.
suasa, 909.
zoe, 407.
- Tericogonia
terissa, 365.
- Terina
fulva, 419.
tenuis, 419.
- Teriomima
freya, 402.
hildegarda, 402.
subpunctata, 402.
- Testudo
ephippium, 587.
galapagensis, 245.
vicina, 587.
- Tetragnatha
boydi, 389, 391.
taylori, 389.
- Tetragonophthalma
stuhlmanni, 518.
- Tetrapriocera
longicornis, 329.
swartzi, 329.
- Tetridia, 600.
- Thais
cerisyi, 80.
polyxena, 80.

Thalassema

- caudex*, 472, 473.
vegrande, 472, 473.
- Thalassicolla
 sp., 1021, 1022.
nucleata, 1021.
- Thalassius, 27, 28.
cunningi, 13, 29, 30, 32.
fimbriatus, 30.
jayakari, 13, 29, 30, 31, 32.
margaritatus, 518, 524.
marginellus, 29.
phipsoni, 13, 29, 30, 31, 32.
spenceri, 13, 29, 32.
unicolor, 28, 29, 30, 32.
- Thecla
hirundo, 406.
- Theretra
tersa, 367.
- Thermesia
gemmatalis, 368.
- Thestor
basuta, 195.
protumnus, 908.
- Thleceria, 602.
- Thliptoceras, 603.
- Thyella
zambesia, 429.
- Thyridospila
vicaria, 425.
- Thyroptera, 58, 75.
- Thysanodesma
discalis, 702.
- Thysanopyga
apicitruncaria, 368.
- Tichoseris
obtusata, 529.
- Tilapia
labiata, 496.
oligacanthus, 147.
- Timetes
chiron, 364.
- Tineodes, 604.
- Tingra
amenaïda, 402.
bertha, 402.
nero, 402.
tropicalis, 195.
- Titanio, 602.
- Titurius, 28.
fimbriatus, 28.
pallidus, 28.
spinosissimus, 28.
- Tityobuthus
baroni, 500.
- Tmeticus
fortunatus, 488.

- Torynesis, gen. nov., 903.
mintha, 903.
- Tracheloptychus
madagascariensis, 816.
- Trachinus
vipera, 296.
- Trachyboa
gularis, 115.
- Trachynema
 sp., 1023, 1030, 1031.
eurygaster, 1032.
funerarium, 1032.
octonarium, 1032.
- Tragelaphus
scriptus, 350.
- Triænops
persicus, 58, 762.
- Trichoptychodes
delicata, 670.
- Trichostola
fuscitarsis, 232.
lefevrei, 232.
- Trigla
gurnardus, 310.
hirundo, 296, 310,
 314.
pini, 310.
- Trigonodes
hyppasia, 423.
- Tripneustes
variegatus, 849.
- Trithyrus, 596, 648.
aurantiacalis, 649.
fenestrinalis, 649.
ignefactalis, 649.
iphiclalis, 649.
janualis, 649.
latifascialis, 649.
nysalis, 649.
perticalis, 649.
prosopealis, 649.
protenoralis, 649.
rubralis, 648.
scyllalis, 648.
sunialis, 648.
- Triton
alpestris, 856.
teniatus, 486.
vulgaris meridionalis,
 483.
- Trochodota
dunedinensis, 846.
purpurea, 846.
studerii, 846.
- Trochosa
leopardus, 488.
- Tropheus, gen. nov.,
 496.
moorii, 496.
- Trotonotus, gen. nov.,
 431.
- Trotonotus
bettoni, 431, 444.
- Tryxalis
nasuta, 384.
- Turbinaria
danae, 262.
mesenterina, 263.
orbicularis, 263.
pulcherrima, 263.
schistica, 263, 276.
- Türkheimia
trifasciata, 419.
- Turdus
iliacus, 3.
pilaris, 3.
- Tylocerus
atricornis, 321.
lineatus, 320, 333.
- Typhæus
orientalis, 445.
- Typhlomolge
rathbuni, 479.
- Typhlomys
cinereus, 769, 772.
- Tyspanodes, 598, 672.
cardinalis, 674.
creaghi, 673, 761.
exathesalis, 673.
fascialis, 673, 674.
flaviventer, 673.
flavolimbalis, 674.
hypsalis, 673.
linealis, 673.
nigrolinealis, 673.
striata, 673.
venosa, 673.
- Ulopeza, 597, 661.
conigeralis, 661.
idyalis, 660, 661.
semivialis, 661.
tenebrosalis, 661.
- Uromastix
ornatus, 915.
- Ursus
americanus, 154, 156,
 159, 160, 162, 163,
 164, 165, 166, 168,
 169, 172, 173, 175,
 177.
arctos, 154, 160, 165,
 167.
maritimus, 154, 156,
 167, 172, 177.
nasutus, 2.
ornatus, 2.
- Uta
wallengreni, 429.
- Uta
symmetrica, 915.
- Varanus
brevicauda, 916, 920,
 923.
eremius, 916.
gilleni, 916.
- Vespertilio
abramus, 78.
becksteini, 78.
grivensis, 75.
minutus, 752.
murinus, 59, 770.
 — *superans*, 770.
mystacinus, 76.
subulatus, 79.
 (Myotis) *murinus*, 59.
- Vesperugo, 58.
anemophilus, 75.
hesperus, 79.
noctivagus, 77.
noctula, 62, 69, 72, 76.
savii, 78.
serotinus, 76.
- Victorina
steneles, 364.
- Virachola
antalus, 54, 196, 407,
 826.
dariaves, 406.
dioces, 406.
livia, 406, 908.
lorisona, 406.
 —, var., 406.
- Vitessa
triplaga, 751.
- Viverra
civetta, 153, 157, 162,
 177, 185, 392.
- Viverricula
malaccensis, 153, 157.
- Voeltzovia
mira, 918.
- Voliba, 594, 611.
major, 701.
scoparialis, 611.
- Xacca
trigonalis, 661.
- Xanthidia
hyona, 365.
- Xanthomelæna, 595, 617.
schematias, 617, 618.
- Xanthospilopteryx
superba, 58.
- Xantusia
vigilis, 916.
- Xenodon
colubrinus, 116.
- Xenopus, 4, 12.
- Xenorhina
atra, 476.

- Xerus**
brachyotus, 765.
dabagala, 765.
flavus, 765.
rutilus, 765.
- Xiphorhamphus**
ferox, 492.
- Xylographus**
suillus, 330.
- Xylopertha**
sex-tuberculata, 329.
- Xysticus**
cristatus, 488.
gallicus, 488.
- Ypthima**
doleta, 188, 369.
maskuna, 188.
pupillaris, 51, 825, 826.
- Zebronia**
abdicalis, 620.
amxnalis, 728.
argyria, 620.
aurolinealis, 728.
bilineolalis, 622.
braurealis, 651.
- Zebronia**
bunusalis, 620.
cassusalis, 728.
cottalis, 636.
dimotalis, 607.
erinalis, 675.
erminea, 675.
indecisalis, 630.
lacrinesalis, 646.
ledalis, 704.
magicalis, 675.
perseusalis, 646.
perspicualis, 651.
phenice, 443.
plexippusalis, 620.
retractalis, 630.
salomealis, 722.
- Zenkerella**
insignis, 454.
- Zeriassa**
bicolor, 522.
spinulosa, 521, 522, 524.
- Zeritis**
amanga, 194, 405, 907.
harpax, 54, 195, 405,
 907.
perion, 405.
- Zethes**
bettoni 425.
hesperioides, 425.
- Zeus**
faber, 311.
- Zilla**
alpina, 488.
- Zinckenia**, 594, 623.
alimenealis, 623.
fascialis, 623.
perfuscalis, 656.
perspectalis, 368, 623.
primordialis, 623.
- Zitha**
varians, 441, 444.
- Zizera**
antanossa, 194, 907.
gaika, 404.
lucida, 194.
lysimon, 380.
- Zonosaurus**
æneus, 916.
laticaudatus, 916.
maximus, 916.
- Zygæna**
cyanoxantha, 440.



THE END.

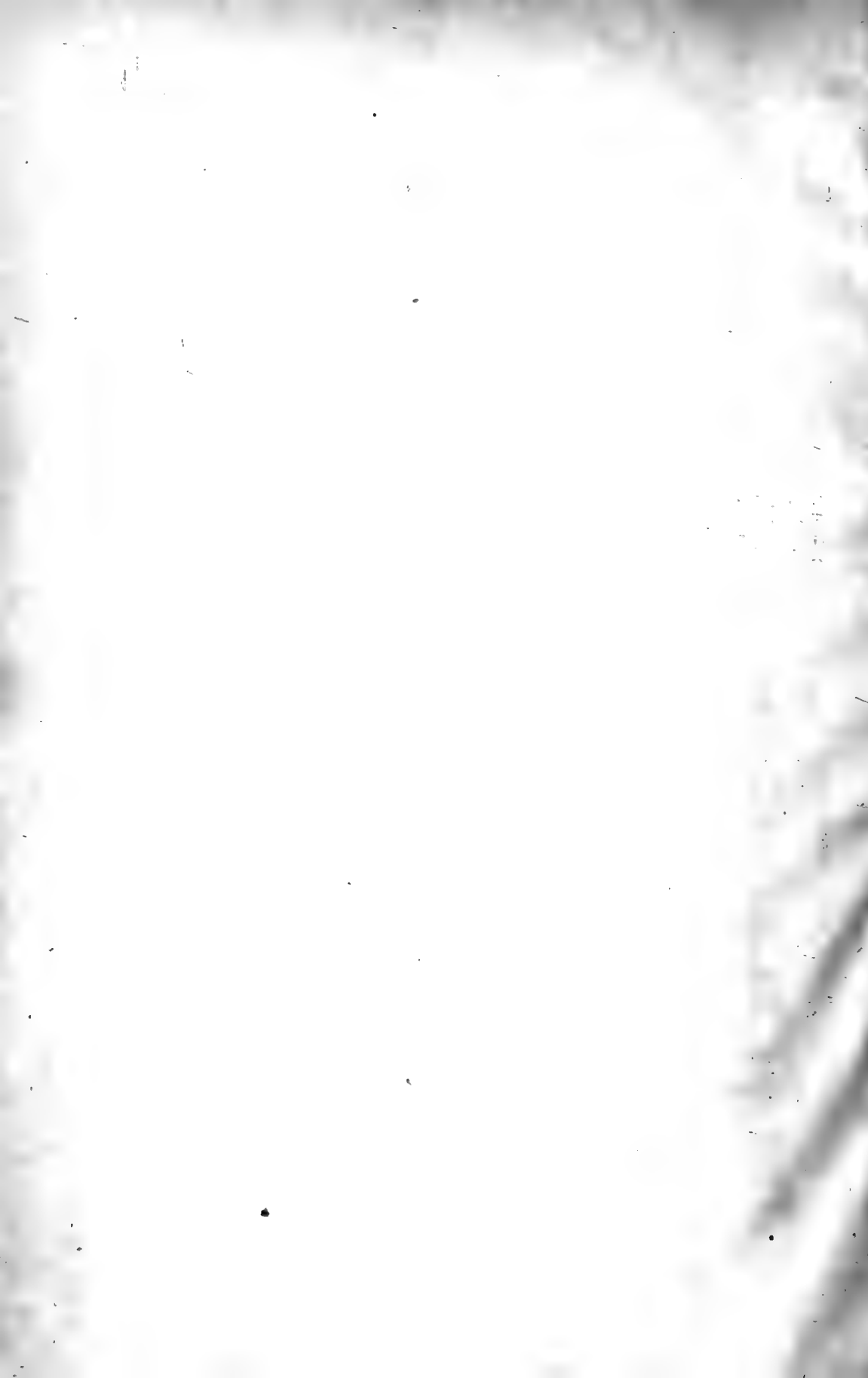

November 29, 1898 (continued).

	Page
Mr. Boulenger. Exhibition of, and remarks upon, a specimen of a Sea-snake (<i>Distira stokesi</i>)	851
Mr. John S. Budgett, F.Z.S. Extracts from a letter from, on his Expedition to the Gambia.	852
Mr. C. W. Andrews. Exhibition of, and remarks upon, some Bird-remains from the Lake-dwellings of Glastonbury, Somersetshire	852
Mr. Oldfield Thomas, F.Z.S. Extract from a letter from Señor Ameghino on the newly discovered Mammal <i>Neomyiodon</i>	852
1. Further Notes on the Amazonian Lepidosiren. By Dr. EMIL A. GOELDI, C.M.Z.S., Pará.	852
2. On the Anatomy of the African Jumping-Hare (<i>Pedetes caffer</i>) compared with that of the <i>Dipodidae</i> . By F. G. PARSONS, F.R.C.S., F.Z.S., F.L.S., Hunterian Professor at the Royal College of Surgeons and Lecturer on Comparative Anatomy at St. Thomas's Hospital	858
3. On new Species of Spiders from Trinidad, West Indies. By FREDERICK O. PICKARD CAMBRIDGE, B.A. (Plate LIV.)	890
4. On the Moulting of the King Penguin (<i>Aptenodytes pennanti</i>) in the Society's Gardens. By W. E. DE WINTON, F.Z.S.	900
5. On a Collection of Butterflies almost entirely made at Salisbury, Mashunaland, by Mr. Guy A. K. Marshall in 1898. By ARTHUR G. BUTLER, Ph.D., F.L.S., F.Z.S., &c. ..	902
6. Third Report on Additions to the Lizard Collection in the Natural-History Museum. By G. A. BOULENGER, F.R.S. (Plates LV.-LVII.)	912

December 13, 1898.

The Secretary. Report on the Additions to the Society's Menagerie in November 1898....	924
Mr. Stanley S. Flower, F.Z.S. Extract from a letter from, on the locality of the Siamang (<i>Hylobates syndactylus</i>)	924
Dr. Henry Woodward, F.R.S. Exhibition of, and remarks upon, an abnormal pair of antlers of the Red Deer	924
1. On certain Characters of reproduced Appendages in Arthropoda, particularly in the <i>Blattide</i> . By H. H. BRINDLEY, M.A., St. John's College, Cambridge. (Plate LVIII.)	924
2. Contributions to the Osteology of Birds.—Part II. <i>Impennes</i> . By W. P. PYCRAFT, A.L.S. (Plates LIX.—LXI.)	958
3. Note on an Anthropoid Ape. By W. L. H. DUCKWORTH, M.A., Fellow of Jesus College, Cambridge	989
4. On the Turbinolid and Oculinoid Corals collected by the Author in the South Pacific. By J. STANLEY GARDINER, M.A., Gonville and Caius College, Cambridge. (Plate LXII.)	994
5. On some Crustaceans from the South Pacific.—Part III. <i>Macrura</i> . By L. A. BORRADAILE, M.A., F.Z.S., Lecturer in Natural Sciences at Selwyn College, Cambridge. (Plates LXIII.—LXV.)	1000
6. Contributions to our Knowledge of the Plankton of the Faeroe Channel.—No. VII. A. General Data of the Stations. B. The Protozoa. C. The Medusæ. By G. HERBERT FOWLER, B.A., Ph.D., Assistant Professor of Zoology, University College, London. (Plate LXVI.)	1016
Appendix: List of Additions to the Society's Menagerie during the Year 1898	1033
Index	1055
Titlepage	i
List of Contributors	iii
List of Plates	xvii
List of Illustrations in the Text	xx
List of New Generic Terms	xxiv

LIST OF PLATES.

1898.

PART IV.

Plate	Page
XLVIII. <i>Cercopithecus lhoesti</i> , ♀	586
XLIX. } <i>Pyralidæ</i> of the Subfamily <i>Pyraustinæ</i>	590
L. }	
LI. Sciagraph of <i>Gnathonemus rhynchophorus</i>	775
LII. } Holothurians from Funafuti and Rotuma	834
LIII. }	
LIV. New Spiders from Trinidad, W.I.	890
LV. Fig. 1. <i>Phyllodactylus siamensis</i> . Fig. 2. <i>Anolis curtus</i> . Fig. 3. <i>Arthroseps weneri</i> . Fig. 4. <i>Lygosoma alfredi</i> .	912
LVI. Fig. 1. <i>Diploglossus nuchalis</i> . Fig. 2. <i>Varanus brevicauda</i>	
LVII. Fig. 1. <i>Lygosoma aignanum</i> . Fig. 2. <i>L. gastrostigma</i>	
LVIII. Tarsi of <i>Blattidæ</i>	924
LIX. Osteology of the Impennes.—Fig. 1. <i>Spheniscus magellanicus</i> . Fig. 2. <i>Pygoscelis papua</i> . Fig. 3. <i>Aptenodytes patagonica</i> . Fig. 4. <i>Eudyptula albosignata</i> . Fig. 5. <i>Catarrhactes chrysocome</i>	958
LX. Osteology of the Impennes.—Fig. 1. <i>Eudyptula albosignata</i> . Fig. 2. <i>Catarrhactes chrysocome</i> . Fig. 3. <i>Megadyptes antipodum</i>	
LXI. Osteology of the Impennes.—Figs. 1, 4, 5. <i>Catarrhactes chrysocome</i> . Figs. 2, 3. <i>Pygoscelis papua</i>	
LXII. Corals from the South Pacific	994
LXIII. } <i>Macrura</i> from the South Pacific	1000
LXIV. }	
LXV. }	
LXVI. Plankton of the Faeroe Channel	1016

NOTICE.

The 'Proceedings' are issued in *four* parts, as follows:—

- Part I. containing papers read in January and February, on June 1st.
- II. " " " " March and April, on August 1st.
- III. " " " " May and June, on October 1st.
- IV. " " " " November and December, on April 1st.

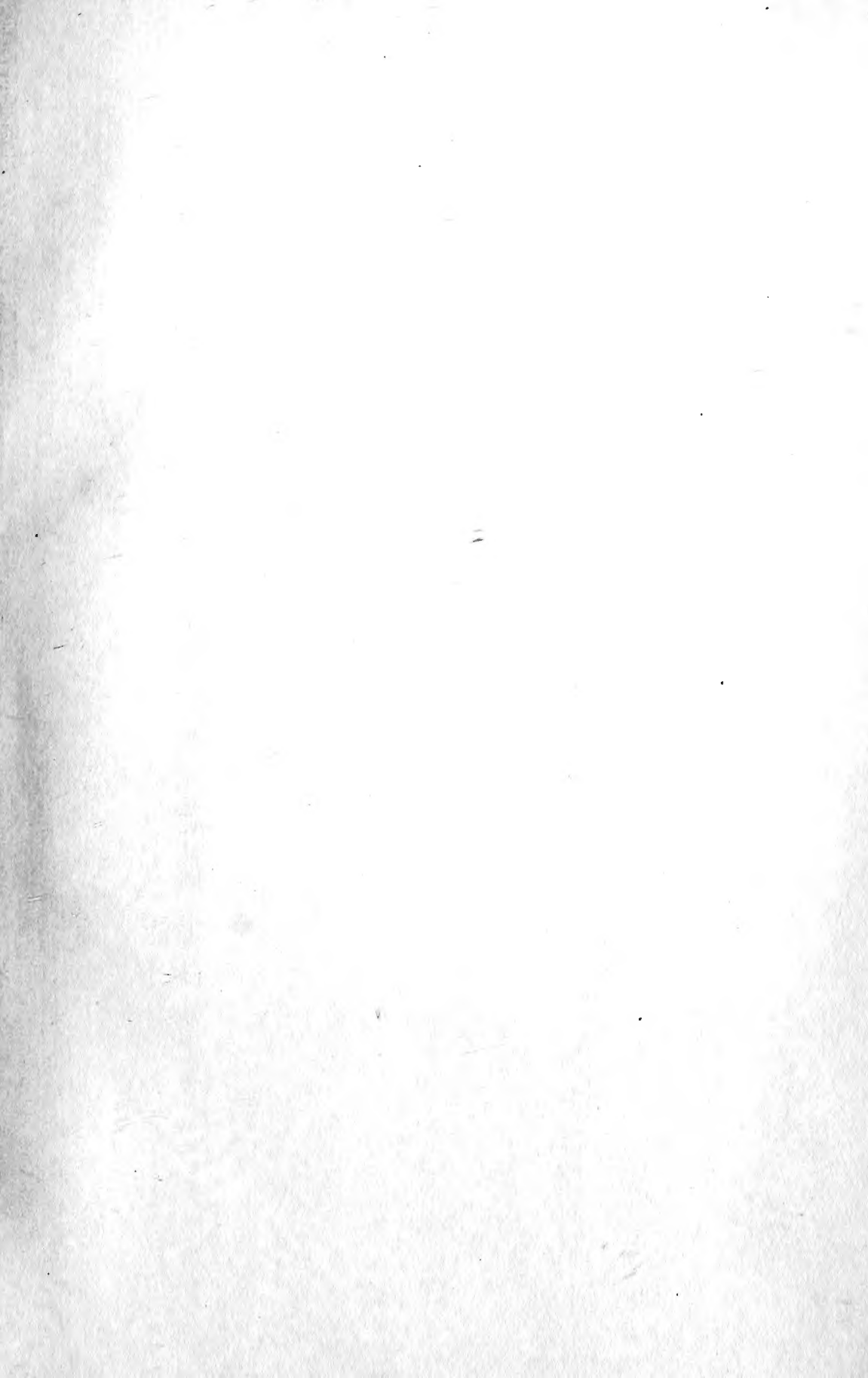

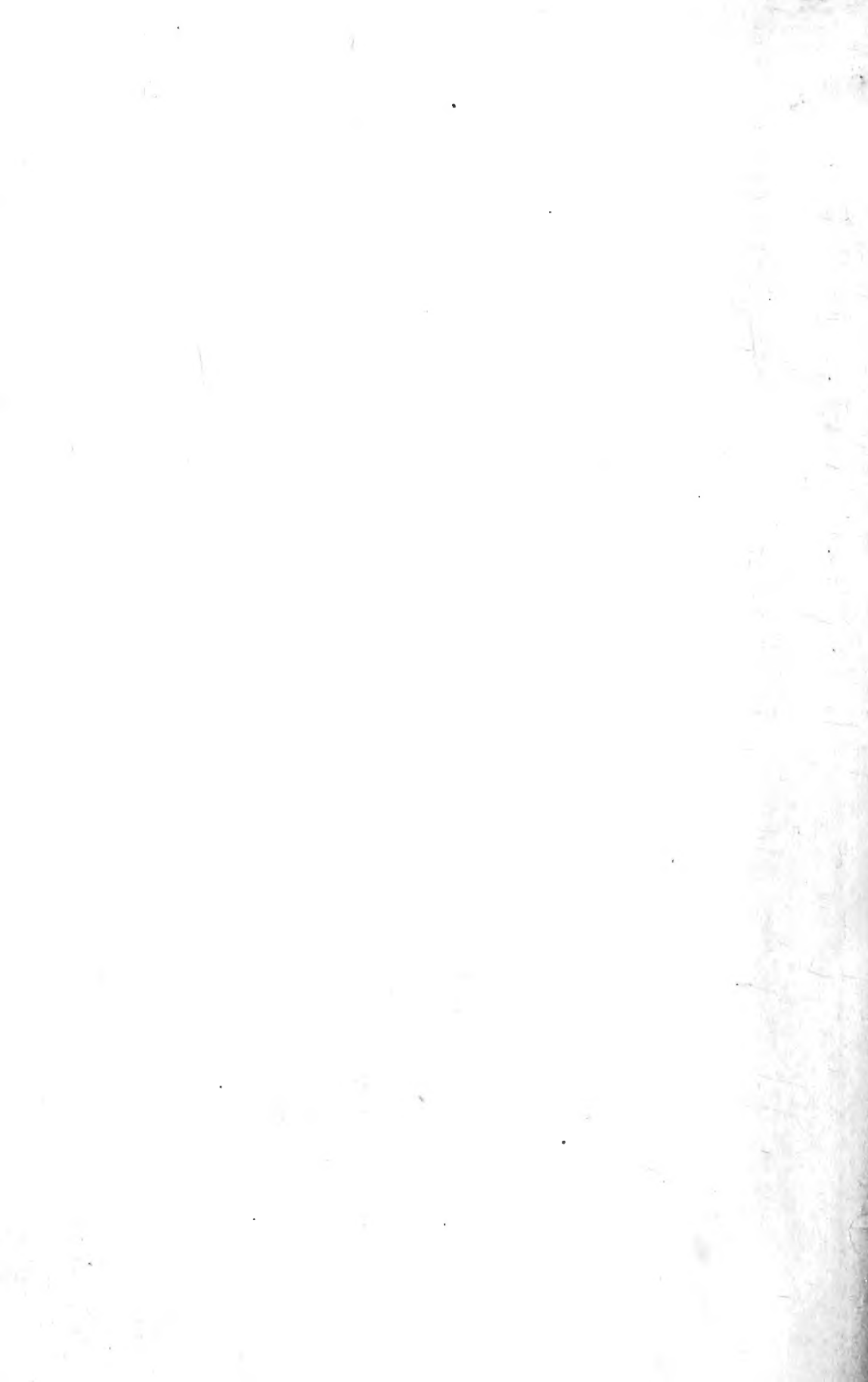

1950-51
2/4 11/9.

