

# COMMON COMMODITIES AND INDUSTRIES

UC-NRLF



B 4 310 034

# SILK

*L. Hooper*



DECORATIVE ART

713



v. wall





# PITMAN'S COMMON COMMODITIES AND INDUSTRIES SERIES

Each book in crown 8vo, illustrated. 3/- net

- Acids, Alkalis, and Salts. By G. H. J. ADLAM.
- Alcohol. By C. SIMMONDS.
- Aluminium. By G. MORTIMER.
- Anthracite. By A. L. SUMMERS.
- Asbestos. By A. L. SUMMERS.
- Bookbinding Craft and Industry The. By T. HARRISON.
- Boot and Shoe Industry, The. By J. S. HARDING.
- Bread and Bread Baking. By J. STEWART.
- Brushmaker, The. By W. KIDDIER.
- Butter and Cheese. By C. W. W. TISDALE and J. JONES.
- Button Industry, The. By W. U. JONES.
- Carpets. By S. BRINTON.
- Clays. By B. SEARLE.
- Clocks and Watches. By G. L. OVERTON.
- Clothing Industry, The. By B. W. POOLE.
- Cloth and the Cloth Trade. By J. A. HUNTER.
- Coal. By H. WILSON.
- Coal Tar. By A. R. WARNES.
- Cocoa and the Chocolate Industry. By A. W. KNAPP.
- Coffee. By B. B. KEABLE.
- Cold Storage and Ice-making. By B. H. SPRINGETT.
- Concrete and Reinforced Concrete. By W. N. TWELVETREES.
- Copper. By H. K. PICARD.
- Cordage and Cordage Hemp and Fibres. By T. WOODHOUSE and P. KILGOUR.
- Corn Trade, The British. By A. BARKER.
- Cotton. By R. J. PEAKE.
- Cotton Spinning. By A. S. WADE.
- Cycle Industry, The. By W. GREW.
- Drugs in Commerce. By J. HUMPHREY.
- Dyes. By A. J. HALL.
- Electric Lamp Industry, The. By G. A. PERCIVAL.
- Electricity. By R. E. NEALE.
- Engraving. By T. W. LASCELLES.
- Explosives, Modern. By S. I. LEVY.
- Fertilizers. By H. CAVE.
- Film Industry, The. By D. BOUGHEY.
- Fishing Industry. By W. E. GIBBS.
- Furniture. By A. E. BINSTED.
- Furs and the Fur Trade. By J. C. SACHS.
- Gas and Gas Making. By W. H. Y. WEBBER.
- Glass and Glass Making. By P. MARSON.
- Gloves and the Glove Trade. By B. E. ELLIS.
- Gold. By B. WHITE.
- Gums and Resins. By E. J. PARRY.
- Incandescent Lighting. By S. I. LEVY.
- Ink. By C. A. MITCHELL.
- Internal Combustion Engines. By J. OKILL.
- Iron and Steel. By C. HOOD.
- Ironfounding. By B. WHITELEY.
- Jute Industry, The. By T. WOODHOUSE and P. KILGOUR.
- Knitted Fabrics. By J. CHAMBERLAIN and J. H. QUILTER.
- Lead. By J. A. SMYTHE.
- Leather. By K. J. ADCOCK.
- Linen. By S. MOORE.
- Locks and Lockmaking. By F. J. BUTTER.
- Match Industry, The. By W. DIXON.
- Meat Industry, The. By W. WOOD.
- Motor Boats. By F. STRICKLAND.
- Motor Industry, The. By H. WYATT.
- Nickel. By B. H. WHITE.
- Oil Power. By S. H. NORTH.
- Oils. By C. A. MITCHELL.
- Paints and Varnishes. By A. S. JENNINGS.
- Paper. By H. A. MADDOX.
- Patent Fuels. By J. A. GREENE and M. PERKIN.
- Perfumery. By E. J. PARRY.
- Petroleum. By A. LIDGETT.
- Photography. By W. GAMBLE.
- Piano Player, The. By D. M. WILSON.
- Platinum Metals. By E. A. SMITH.
- Pottery. By C. J. NOKE and H. J. PLANT.
- Rice. By C. E. DOUGLAS.
- Rubber. By C. BEADLE and H. P. STEVENS.
- Salt. By A. F. CALVERT.
- Shipbuilding and the Shipbuilding Industry. By J. MITCHELL.
- Silk. By L. HOOPER.
- Silver. By B. WHITE.
- Soap. By W. H. SIMMONS.
- Sponges. By E. J. J. CRESSWELL.
- Starch and Starch Products. By H. A. AUDEN.
- Stones and Quarries. By J. A. HOWE.
- Straw Hats. By H. INWARDS.
- Sugar. By G. MARTINEAU.
- Sulphur and Allied Products. By H. A. AUDEN.
- Talking Machines. By O. MITCHELL.
- Tea. By A. IBBETSON.
- Telegraphy, Telephony, and Wireless. By J. POOLE.
- Textile Bleaching. By A. B. STEVEN.
- Timber. By W. BULLOCK.
- Tin and the Tin Industry. By A. H. MUNDEY.
- Tobacco. By A. E. TANNER.
- Velvet and the Cordurj Industry. By J. H. COOKE.
- Wall Paper. By G. W. WARD.
- Weaving. By W. P. CRANKSHAW.
- Wheat. By A. MILLER.
- Wine and the Wine Trade. By A. SIMON.
- Wool. By J. A. HUNTER.
- Worsted Industry, The. By J. DUMVILLE and S. KERSHAW.
- Zinc. By T. E. LONES.





Tapestry Woven Silk Panel of the Egypto-Roman Period. It probably formed part of a child's tunic. The original is 4" × 4" in size, and is in the Textile Collection of the Victoria and Albert Museum.

*From a water-colour drawing by the Author*



PITMAN'S COMMON COMMODITIES  
AND INDUSTRIES

SILK

ITS PRODUCTION  
AND MANUFACTURE

BY

LUTHER HOOPER

WITH AN APPENDIX ON  
THE FIRE HAZARDS INCIDENTAL  
TO SILK MILLS AND FACTORIES

BY

T. D. RAINE, F.C.I.I.



*SECOND EDITION*

LONDON  
SIR ISAAC PITMAN & SONS, LTD.  
PARKER STREET, KINGSWAY, W.C.2  
BATH, MELBOURNE, TORONTO, NEW YORK

DECORATIVE ART

PRINTED IN GREAT BRITAIN  
AT THE PITMAN PRESS, BATH

T 51665  
 H 6  
 1919  
 ENVI

# CONTENTS

CHAP.	PAGE
I. THE VALUE OF SILK AND SOURCE OF SUPPLY . . . . .	1
II. THE SILKWORM . . . . .	5
III. VARIETIES OF SILK-PRODUCING MOTHS . . . . .	12
IV. HISTORY OF SILK AND SERICULTURE . . . . .	17
V. THE PRACTICE OF SERICULTURE . . . . .	25
VI. REELING FROM THE COCOONS . . . . .	33
VII. SILK THROWING AND WINDING . . . . .	37
VIII. SILK DYEING . . . . .	48
IX. VARIETIES OF SILK THREAD . . . . .	59
X. ANCIENT SILK WEAVING . . . . .	62
XI. THE ORNAMENTAL SILK WEBS OF CHINA . . . . .	73
XII. THE SIMPLE AND COMPOUND DRAW-LOOM FOR SILK WEAVING . . . . .	79
XIII. SATIN DAMASK WEAVING . . . . .	94
XIV. SILK WEAVING IN THE EAST TO A.D. 1200 . . . . .	99
XV. THE INTRODUCTION OF SILK WEAVING INTO EUROPE . . . . .	102
XVI. DEVELOPMENT OF EUROPEAN SILK WEAVING, THIRTEENTH TO SIXTEENTH CENTURY . . . . .	107
XVII. ENGLISH SILK WEAVING TO ABOUT 1800 . . . . .	111
XVIII. MODERN SILK WEAVING . . . . .	114
XIX. SPUN SILK . . . . .	121
APPENDIX . . . . .	125
INDEX . . . . .	135



# ILLUSTRATIONS

PANEL OF WOVEN SILK, 4TH CENTURY . . . . .	<i>Frontispiece</i>
	PAGE
THE SILKWORM MOTH . . . . .	4
THE SILKWORM . . . . .	5
PLATE 2. A. LIFE HISTORY OF A SILKWORM . . . . .	7
,, B. TITLE PAGE OF AN 18TH CENTURY BOOK . . . . .	7
LONGITUDINAL SECTION OF FULL-GROWN SILKWORM . . . . .	9
FIBROIN APPARATUS . . . . .	9
WINDING THE FIBRE . . . . .	11
CATERPILLAR OF TUSSER MOTH . . . . .	12
ANTHERÆA YAMA-MAI . . . . .	14
ANTHERÆA PERNYI . . . . .	14
TUSSER MOTH, ANTERÆA MYLITTA . . . . .	16
PLATE 3. A. CHINESE VOTIVE OFFERINGS . . . . .	18
,, B. PERSIAN MONKS AND JUSTINIAN . . . . .	18
MORUS ALBA—THE CHINESE MULBERRY . . . . .	25
PLATE 4. A. SILKWORM BREEDING EXTRAORDINARY . . . . .	30
,, B. CHINESE COCOON REELING . . . . .	30
MORUS INDICA—THE INDIAN MULBERRY . . . . .	32
REELING MACHINE . . . . .	35
WINDING MACHINE . . . . .	38
CLEANING MACHINE . . . . .	41
SPINDLE AND FLIER . . . . .	43
DOUBLER . . . . .	44
DYE STICK . . . . .	50
DYE BARC . . . . .	51
TURNING THE SKEINS . . . . .	52
DYE BARC IN USE . . . . .	53
WRINGING . . . . .	54

	PAGE
PLATE 5. A. A FRENCH DYEHOUSE, 18TH CENTURY . . . . .	55
,, B. A MEDIÆVAL DYER . . . . .	55
TAPESTRY WEAVING . . . . .	63
PLATE 6. A. POWER-LOOM TISSUE (MODERN) . . . . .	64
,, B. CHINESE IMPERIAL ROBE . . . . .	64
TABBY WEAVING . . . . .	66
HEADLES FOR OPENING THE WARP OR SHED. . . . .	68
THE SATIN WEB . . . . .	70
INTERSECTIONS EXPRESSED ON DESIGNER'S RULED PAPER . . . . .	70
SATIN WEAVING . . . . .	71
DRAGON, FROM AN ANCIENT CHINESE PAINTING . . . . .	73
PLATE 7. A. CHINESE SATIN WITH EMBROIDERY . . . . .	74
,, B. CHINESE DRAW-LOOM . . . . .	74
A COMBER BOARD . . . . .	80
A COMBER BOARD LEASH . . . . .	81
DRAW-LOOM MONTURE . . . . .	82
DIAGRAM SHOWING ONE CORD OF THE DRAW-LOOM . . . . .	84
DESIGN AND TIE-UP ON THE SIMPLE CORDS . . . . .	85
DOUBLE-HARNESS WEAVING . . . . .	88
DIAGRAM OF DOUBLE HARNESS . . . . .	89
POINT REPEATING MONTURE . . . . .	91
PLATE 8. A. CHINESE SILK DAMASK . . . . .	93
,, B. CHINESE BROCADE WITH PERSIAN IN- SCRIPTION . . . . .	93
DRAUGHT OF SATINS . . . . .	95
DIAGRAM OF DOUBLE HARNESS . . . . .	97
WOVEN ARABIC INSCRIPTION . . . . .	99
COPTIC ORNAMENT . . . . .	101
SICILIAN WOVEN ORNAMENT . . . . .	102
PLATE 9. A. SPANISH MORESCQUE 15TH CENTURY . . . . .	103
,, B.     ,,     ,,     ,,     ,,     ,, . . . . .	103
SICILIAN DAMASK. THE HART AND SUNDOG DESIGN . . . . .	108

# SILK

## CHAPTER I

### THE VALUE OF SILK AND SOURCE OF SUPPLY

**The Importance and Commercial Value of Silk.**—The important and interesting subject to be dealt with in the present volume of the Commodities of Commerce series is a very wide one, so that it will only be possible within the limits at disposal, to give the reader a general idea of the several matters opened up, and refer the student, who may be desirous of following them out in greater detail, to the various authorities he may consult with advantage.

The textile industries, both of the past and present, loom very large amongst the necessary arts of life ; and it may be affirmed with truth that the richest, most ingenious and beautiful, as well as the most commercially valuable, branches of the weaver's and embroiderer's crafts, are those in which is manipulated the smooth, tenacious, and lustrous thread, called by the ancients *Ser* or *sericum*, and by us to-day, *silk*.

It will be seen, as the subject is developed, that silk well deserves the esteem in which it has been held for at least three or four thousand years. Because of its fineness, strength and lustre, as well as its affinity for rich and delicate dyes, it has enabled the weaver and embroiderer to produce, by the intersection of its

threads in various combinations, the most beautiful and elaborate ornamental designs, and to colour them with the tints of the rainbow. In the third century, the monk Dionysius Perigates wrote of the Chinese, or *Seres*, as they were then called: "The Seres make precious figured garments resembling in colour the flowers of the field, and rivalling in fineness the work of spiders."

The commercial value of the silk industries, in the present day, may be gathered from the fact that the silk thread produced annually in Europe is estimated to be worth thirty millions of pounds sterling, and in Europe and Asia combined, about seventy millions. These figures can, however, only be taken as approximate, for the statistics with regard to China, which is still the greatest producer and consumer of silk, are extremely difficult to gather and very unreliable. It is probable that the value of the silk produced in Asia is much greater than is stated above.

**The Chemical Composition of Silk Fibre.**—When the natural fibre of silk is microscopically and chemically examined it is found to consist chiefly of two substances, called respectively Fibroin and Serecin. To these is added a very trifling amount of waxy, and more or less colouring matter. Both fibroin and serecin are composed of four elements: carbon, hydrogen, nitrogen, and oxygen. In serecin there is a rather larger proportion of hydrogen and oxygen than in fibroin. The chemical formulæ for the two substances are for fibroin  $C_{15}H_{23}N_5O_6$  and for serecin  $C_{15}H_{25}N_5O_8$ .

The fibroin is a horny kind of substance, and forms the core of the fibre. It is insoluble in water even when boiling. The serecin is on the surface of the fibre (see Section, Fig. 1), and the excess of hydrogen and oxygen in its composition renders it soluble in boiling



water. It is commonly called silk gum. The proportions of fibroin to sericin in the natural fibre are about two parts of fibroin to one of sericin.

Although fibroin is not soluble in water, it is highly *hygroscopic*, and it will absorb as much as 33 per cent. of water without feeling damp to the touch.

When freed by boiling from the gum, the fibre assumes the appearance of pure silk, with its pearly lustre and soft brilliance. The wax and colouring matter disappear in the boiling, together with the silk gum.



FIG. 1

Pure boiled silk, although insoluble in water, alcohol, or ether, is freely acted upon by strong alkaline solutions, acids, and solutions of ammonia and oxide of copper.

**Silk Produced Naturally a Continuous Thread.**—Not only on account of its richness and lustre is silk distinguished from all other fibres, but because it is naturally produced in a continuous thread several hundreds of yards in length. All other fibres have to go through numerous preliminary joining and twisting processes before they become thread; but, except that several strands have to be twined together in order to make it thick enough to use effectively, the natural thread of silk is produced quite ready for use.

**Extreme Fineness of the Fibre.**—The extreme fineness of this wonderful fibre can hardly be realized. One ounce of natural silk, wound and measured, is found to *run*, as it is called, a hundred thousand yards in length. The silk thread is produced double (see Fig. 1), two strands of fibre being slightly twisted together, as will presently be shown.

**Strength of the Fibre.**—In proportion to its size, this extremely fine thread, which is about the three thousandth part of an inch in thickness, is of extraordinary strength. Tables, the results of scientific experiments on the elasticity and tenacity of the *Bave*, the French name for the natural fibre, are to be found in technical works on the subject published in France.<sup>1</sup> These may be consulted by the student, but the measurements and weights are so infinitely small, that they can convey no idea to the general reader. It will be sufficient here to note that a twisted thread of silk fibres, finer than the finest human hair, will stretch five or six inches to the yard, and bear a weight of from twelve to sixteen ounces. Also that a cable of silk would sustain a heavier weight than one of equal size composed of any other fibre.

**Source of the World's Supply of Silk.**—The natural supply of silk for the whole world for, say, 4,000 years, the monetary value of which is incalculable, has depended almost entirely upon the instinct of the caterpillar of a most inconspicuous moth to provide for itself a snug case in which its metamorphosis into its perfect form might be effected.

<sup>1</sup> Sir Thomas Wardle gives some tables in his *Silk at the Manchester Exhibition*. (Bumpus, Holborn, London.)



FIG. 2. THE SILKWORM MOTH



FIG. 3. THE SILKWORM

## CHAPTER II

### THE SILKWORM

**First Classic Allusion to the Silkworm.**—ARISTOTLE, in his *History of Animals* (Book 5, Chap. xvii, Section 6), describes "a certain great worm which has, as it were, horns, and differs from all others. At its first metamorphosis it produces a *Kampe*, afterwards a *Bombukion*, and lastly a *nakudalas*. It passes through all these forms in six months. From this animal some women unroll and separate the bombukina, and afterwards weave them. It is said that this was first done in the island of Kos by Pamhila, the daughter of Plateos."

This first allusion to the silkworm in literature is most interesting, and, although it is not altogether correct in detail, it proves beyond doubt that silk was used for weaving in classic times. It also shows that the natural source from which the thread was obtained, was pretty accurately known in ancient Greece. It gives, too, the origin of the name by which the family of moths, to which the silkworm moth belongs, is known, the *Bombycinæ*. The silkworm moth itself is the *Bombyx Mori*, so-called because the caterpillar feeds on the *Morus Alba*, or Chinese white mulberry tree.

**Description of the Silkworm.**—At the head of this

chapter the silkworm is drawn full size, ready to change into the chrysalis or *pupa* form. It is a repulsive-looking creature, especially when full-grown, but is admirably fitted for its duty in life, which is to feed voraciously, and to manufacture, in its wonderful internal laboratory, the fibroin and sericin, which will afterwards become the lustrous silk fibre.

Before enquiring into the interior anatomy of the caterpillar and its life story, it will be well to describe the structure and functions of the creature as far as they can be gathered from the exterior view. This shows that, in common with all caterpillars, the silkworm's structural framework consists of twelve concentric rings of cartilage which are connected together by soft and elastic skin. Its head is extremely small in proportion to the creature's size, and is furnished with two very powerful *mandibles* or jaws, in which are set sharp grinders for tearing up and masticating its food. The mouth is only used for eating, as respiration is carried on through the black spots which may be seen on most of the concentric rings. These spots are openings which lead to the respiratory ducts, and these, in turn, are in communication with the venous system. There are three pairs of hook-like feet quite near the head, fitted for catching hold of and clinging to thin stems and the edges of the leaves on which the caterpillar feeds. There are also ten pads for sustaining the weight of the creature's body, one pair of these being placed on the sixth, seventh, eighth, and twelfth rings respectively. The caterpillar moves about by means of first hunching up its back and drawing forward its hinder parts, then holding on with its pads and extending the front portion of its body to its full length. There are no horns, as mentioned by Aristotle, but there are two or three, more or less



developed, spines on the caterpillar's back, the largest one being above the hindmost ring of cartilage.

**Life Story of the Silkworm Moth.**—At A, Plate 2, the life story of the *Bombyx Mori* is given. At the top of the photograph a few eggs are shown. Of these, the female moth lays a very large number. They are very minute, and so light that 40,000 only weigh about an ounce. This number is sufficient to stock a small silkworm farm for one season. When first laid by the moth, in the summer, they are pink in colour, but soon change to a dark grey, and so remain until they are hatched in the following spring, for the *Bombyx Mori* only breeds once annually in temperate climates.

The growth of the *larva* or caterpillar, as soon as it is hatched, is very rapid. It at once attacks the edges of the leaves on which it is placed, and in a few days grows too large for its skin, even though the latter is very elastic. It then ceases feeding, and a new skin having formed, it casts the old one by moving backwards out of it. When free, it begins feeding again voraciously. This change of skin occurs four times in about six weeks, by which time, if healthy, the caterpillar will measure three inches in length, weigh the ninth part of an ounce, and appear like the full-grown silkworm represented feeding on the top edge of the leaf in A, Plate 2, and in Fig. 3. Caterpillars at various stages of growth are also shown feeding on the leaves at A, Plate 2.

**The Apparatus for Making Fibroin.**—Fig. 4 is the longitudinal section of a full-grown silkworm, taken for the purpose of showing the apparatus in which the fibroin is made and stored. 1, 1 is the main artery of the organism which is in communication with the respiratory ducts; 2, 2 is the alimentary canal or digestive tube, into which all the food the creature devours enters after being masticated; 3 is the fibroin

reservoir and apparatus. The curiously twisted tube, which begins just below the posterior spine and terminates in the reservoir at its end towards the beginning

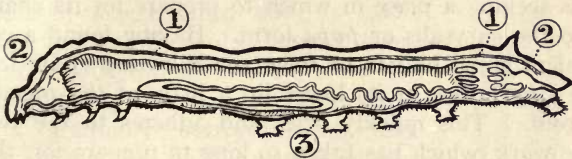

FIG. 4

of the canal, is the laboratory in which the fluid fibroin is made. Between the other end of the reservoir and the creature's mouth another twisted tube is seen; this terminates in an orifice in its lower lip. This tube is for the purpose of preparing the liquid silk for discharge and emitting it when required for use in forming the case or *cocoon*. A reference to Fig. 5, in which the fibroin



FIG. 5

apparatus is drawn separately and from above, will show that the reservoir and tubes are double and are placed in the two sides of the digestive canal. The preparation tubes, the reservoirs, and the discharging tubes are numbered, in Fig. 5, Nos. 1, 2, and 3 respectively.<sup>1</sup>

<sup>1</sup> Silk gut, which is used by fishermen, because of its strength, lightness, and insolubility in water, is made from the fibroin apparatus of the silkworm. When full-grown, the caterpillar is killed, and the reservoir and tubes extracted. Being elastic and the fibroin in a jelly form, they allow of being stretched out to a considerable length, and are moulded to an even size by the fingers of the operator. The stretched line is then left to dry in the sun and after this is ready for use.

**The Cocoon.**—The caterpillar, being full-grown, ceases to feed, appears restless, and its skin changes to a semi-transparent, pinky flesh colour. These are signs that it is seeking a place in which to prepare for its change into the chrysalis or *pupa* form. Having found a convenient small branch or twig, the silkworm emits from the tiny orifice in its lower lip a little of the precious fibroin. This quickly dries and adheres to the twig. The work, which has taken so long to prepare for, then commences. By a mysterious waving motion of its head, and a slow circular motion of its body, it gradually envelops itself in a bombukion, as Aristotle named it, of Fibroin, drawn out from its lip in a minute double thread, slightly twisted, and united by sericin or silk gum, into a solid case or, as it is now called, a *cocoon*.

**Use of the Wax.**—It is supposed that the wax, traces of which are found in the natural silk fibre, is for the purpose of lubricating the orifice from which the thread is rapidly drawn out.

**Cause of Variety in Colour of Fibre.**—The variety of colouring matter, which is added to the fibre in the discharging tubes, in different breeds of silkworms, is probably due to the particular kind (for there are several) of mulberry tree, on the leaves of which the caterpillar has been fed.

**Sericin, how Made.**—Some authorities believe that the extra hydrogen and oxygen are also added to the stream of fibroin, changing it, on the outside, to sericin, as it passes along the discharging tube. But the latest theory is that the excess of these elements is gathered from the atmospheric air as the fibre emerges from the orifice in a semi-liquid state.

**Making of the Cocoon.**—The fibre is not wound in the cocoon as in an ordinary ball, but in the ingenious twisted manner shown in Fig. 6.



When once started, the operation is seldom, if ever, broken off until the supply of fibroin is exhausted. When finished, the double thread varies in length from 500 to 1,300 yards, and can be readily wound off in a continuous thread.

The caterpillar thus encloses itself in a gradually narrowing cell, and then, after its giddy work, quietly carries on its metamorphosis into the *Imago* or moth, furnished with four wings, six legs, and two feathery antennæ. (See Fig. 2.)

When thus complete and its hybernation is finished, the moth breaks through its prison walls, its wings expand and dry, and it enters into its perfect state.

**Brief Life of the Moth.**—The moth only lives a very few hours after all this preparation. Its only business is to arrange for the next generation of its kind. It never eats, for its mouth is atrophied; it seldom, if ever, uses its wings, except to flutter weakly. The female just lays her eggs and then dies, a melancholy victim to centuries of domestication and specializing in silk.

Until quite recently, it was supposed that the *Bombyx Mori* was the only moth worth cultivating extensively for silk, but it has now been found that many other varieties of silk-producing moths are worth attention. Some of these will be considered in the next chapter.

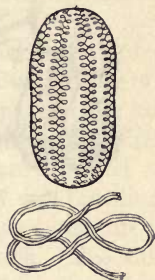

FIG. 6.

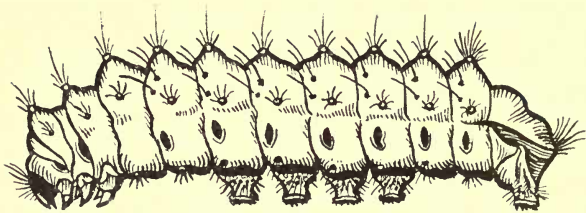

FIG. 7. CATERPILLAR OF TUSSER MOTH

## CHAPTER III

### VARIETIES OF SILK-PRODUCING MOTHS

**Other Varieties of Silk Moths.**—Although by far the greatest quantity of silk, as well as the finest, strongest, and most perfect fibre, is produced by the annual silkworm of temperate climates, there is a great deal of silk obtained in India and other hot countries from the mulberry-feeding varieties of silk moths that belong to the *multivoltine* classes, that is, those that breed several times a year. This silk is often very bright and exquisitely soft, but lacks the strength of that produced by the *univoltine* or annual breeders. This is especially the case where the silkworms are domesticated, as nearly all the mulberry-feeding varieties are.

**Indian Tusser Silk.**—By far the greatest quantity of silk produced and used in India, is obtained from the cocoons of the wild Tusser moth, the caterpillar of which feeds on the oak and other trees in the jungles of Central and Southern India. It is quite probable that if the same care were given to the breeding, rearing, and feeding of this silk producer, much improvement might

be effected in the quality of the fibre, for its strength and elasticity are remarkable. Fig. 7 represents the caterpillar of the Tusser moth, two-thirds its actual size.

**Breeding of Tusser Silkworms.**—The method adopted by the natives who engage in the Tusser silk industry is a very rough and ready one. In the early part of the hot weather, when the foliage is thin, search is made in the jungle for fresh cocoons. The moths are allowed to emerge from these, and are chiefly used for breeding. They very soon lay their eggs, which are hung up in the branches of trees chosen to receive them. The silkworms which emerge from these eggs are allowed to travel about the foliage and feed at will. During the time when the caterpillars are feeding upon the trees in the open air, heavy rain is of daily occurrence, and without this frequent watering, which no doubt keeps them clean, they will not thrive. The rearers carefully watch over the trees to protect the caterpillars from bats, rats, and other enemies. While the rearing is going on they also observe many ceremonial rites.<sup>1</sup>

Wild Tusser silk, in common with all oak-feeding silkworms' silk, is strongly impregnated with tannin, which has to be thoroughly discharged before the silk can be dyed. This was formerly an obstacle to its general use, but the difficulty has, to a great extent, been overcome, and satisfactory effects of dye on Tusser silk can now be obtained.

<sup>1</sup> See No. 23 *Handbooks of Commercial Products* (Indian Section, Imperial Institute Series). Much useful information on the varieties of other silk-producing moths in India will be found in it. The late Sir Thomas Wardle gave much attention to the silk-producing industries of India, and wrote largely on the subject. All his books are worth consulting, and give much information.

The Atlas moth is the largest of all the many varieties of silk-producing *lepidoptera*. It is a native of India, and its freedom, strength, and splendour render it a remarkable contrast to its diminutive but industrious relation, the *Bombyx Mori*. Its silk, however, is of little value.

Two important members of the oak-feeding species of silk moths must now be noticed. The *Antheræa Yama-Mai* (Fig. 8) is a native of Japan, where it is much prized

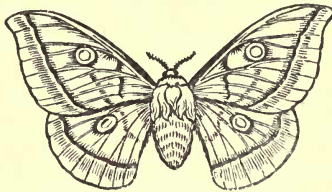

FIG. 8. ANTHERÆA YAMA-MAI. (*one-third natural size*)

and carefully bred. The moth is a beautiful insect, of a bright yellow colour, and often measures 6 inches across the wings. Its cocoon is as large as a pigeon's egg, and the silk, though similar to Tusser, is much finer and more lustrous. This is no doubt owing to the care bestowed on its breeding and rearing.

The *Antheræa Pernyi* (Fig. 9) is a Chinese insect.



FIG. 9. ANTHERÆA PERNYI (*one-third natural size*)

It is reared in a semi-domesticated state in that country upon oak trees, and produces a large amount of valuable silk.

In Central Africa, between 15° N. and 25° S., the *Anaphe*, a curious species of silk-producing moth, is found. It is thought that this species may become of considerable commercial importance.

The caterpillars are found in great abundance. They combine into groups, spin a nest together, and each insect spins its individual cocoon inside the nest. They breed and develop very quickly, the caterpillar being hatched a very few days after the eggs are laid.

When the moths have broken through the cocoons and flown, the empty nests are collected, and, after being cleaned, are torn to pieces and sent to the spinning mills to be made into spun silk thread. This industry is yet in its infancy, and it seems that no attempt has yet been made to reel silk from the cocoons, which, as we shall see later, would, of course, have to be done before the flight of the moths had spoiled them for winding.

It is said that altogether there are between four and five hundred species of silk-producing moths at present classified. But a large proportion of these are of no commercial value whatever, because either the amount of silk they spin is so small that it is a negligible quantity, or, it may be, the silk itself is too poor and weak to be of use, or the moth is so scarce, that the species is not worth considering for its silk. It is possible, however, that there are many which could be utilized in the same way as the African species just described. These have hitherto been neglected, because of the difficulty of collecting and reeling the silk before the flight of the moth. It is likely that in the future, spun silk will be

much more in demand than it has yet been. Should this be so, such discoveries as that of the abundance and utility of the African nesting species will be invaluable.

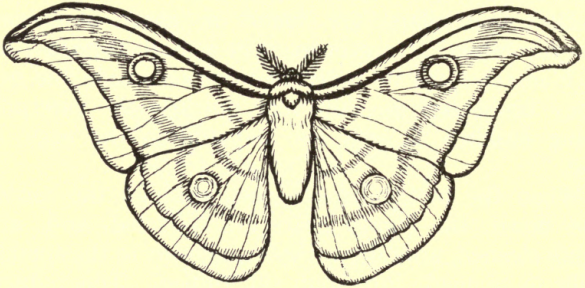

FIG. 10

TUSSER MOTH, *ANTHERÆA MYLITTA* (*half natural size*)

## CHAPTER IV

### HISTORY OF SILK AND SERICULTURE

**Antiquity of Sericulture.**—The history of the utilization of silk, and the domestication of the silkworm, is a most interesting one. It goes back to a period far earlier than that of the first definite description of the silkworm given by Aristotle, which has already been referred to.

**Seventeenth Century Books on Sericulture.**—During the seventeenth and eighteenth centuries the silkworm was an object of much interest and speculation in Europe, and many books and pamphlets were issued relating to the subject of its origin, habits, and history. On many points these books are most useful; they are always interesting, and in many cases are beautifully illustrated and printed. They are, however, more amusing than helpful when they attempt to deal with early times, and remote countries. B, Plate 2, gives the title-page of a book which, published in 1733, is a delightful example of this bibliography of the silkworm.<sup>1</sup> In his introduction, the author of the work, after referring to the account of the sixth day of creation in the Book of Genesis, discusses the probability of antediluvian sericulture, and thinks it likely that Noah, after the flood, settled in China and originated sericulture in that country. Here we must leave the author at present and turn to the Celestial Empire, for, whether Noah settled there or not, there can be no doubt that China was the natural home of the silkworm

<sup>1</sup> National Art Library, South Kensington, London.



A, PLATE 3. CHINESE VOTIVE OFFERINGS  
 (See p. 19)  
*(Victoria and Albert Museum)*



B, PLATE 3. PERSIAN MONKS AND JUSTINIAN  
 (See p. 22)  
*(National Art Library, South Kensington)*



in ancient times, and that sericulture was highly developed by the Chinese at a very remote period.

**Name of China derived from Silk.**—The name CHINA is derived from *Ssü*, which is the Chinese word for silk. All the names by which China was known to the ancients were also derived from that of the precious fibre. *Seres*, *T'sin*, *Sinem*, *Sereca*, and others all signify the land of silk.

China is said to have an uninterrupted literary history which goes back to between two and three thousand years B.C., and in it there are many references to the silkworm, sericulture, silk weaving, and silk embroidery.

**First Mention of Silk in Chinese History.**—The first direct mention of silk in Chinese history is in connection with the wife of the Emperor W'Hang, who reigned B.C. 2500. This emperor was a great patron of agriculture, and his empress was the first to cultivate the silkworm. To her also is attributed the invention of the loom for weaving silk into the patterned webs, which were not only prized in China itself, but were exchanged for more than their weight in gold in India, Persia, Greece, and Rome.

During the reign of this Emperor W'Hang the annual festivals of agriculture and sericulture, which are still held in China, were first instituted. In these festivals, among other ceremonies, the reigning emperor ploughs a furrow, and the empress makes an offering, at the altar of her deified predecessor, of cocoons and mulberry leaves.

A, Plate 3, is photographed from a Chinese drawing, and represents a Chinese family making votive offerings at the shrine of the royal sericulturalist, the ancient Empress Hsi-Ling-Shih. This picture is from an illustrated book on sericulture and tillage. The first edition was published in China in 1210 A.D., and twenty-three pictures and descriptive poems are devoted to silk-winding, weaving, and sericulture.

**Secret of Sericulture kept by the Chinese.**—The Chinese, always a wily nation, used to tell foreigners, when asked as to the origin of silk, that it was obtained from the fleeces of sheep, which, on being sprinkled with water in the sunshine, at certain seasons in the year, abounded with fine threads. These, on being combed out, were found to be of fine silk, ready for weaving.

Herodotus and Pliny both say that some kinds of silk are a vegetable growth, evidently confusing it with the fine cotton of India.

The secret of sericulture, though not perhaps that of the actual source of supply, was thus most carefully guarded by the Chinese, and it is pretty certain that it was successfully kept until about 300 A.D.

Very little silk was used for weaving outside of China in ancient times, but Chinese woven silks and embroideries were extensively exported and much prized.

**Ancient difficulty of obtaining Silk Thread for weaving.**—As silken thread, for weaving and embroidery, could not to be obtained from China in ancient times, it was customary to purchase the plain woven silks and unweave them for the sake of the precious thread which the Chinese not only made up so perfectly, but dyed in the most lovely and varied colours. This was, no doubt, what was done in the island of Kos, mentioned by Aristotle in the quotation already made. Kos was an island near the coast of Asia Minor, and probably the weavers there had facilities for obtaining these loosely woven, plain coloured, Chinese webs. This may have been so or not, but it is certain that the silk used by the Egypto-Roman, Saracenic, and Byzantine weavers was obtained in this manner until the fifth or sixth centuries A.D.

Plate 1 (the frontispiece) is a panel of Egypto-Roman silk tapestry weaving. It is referred to here as an

example of the use of silk obtained by unravelling Chinese webs, but its method of work and other points will be described later on.

Seeing that silk thread was so precious, and obtained with so much difficulty, it is not surprising that very little silk was used for weaving in ancient times. Linen and wool were the materials on which the ancient weavers, outside China, exercised their skill.

**Introduction of Silk to Japan.**—It is recorded in Japanese history, that, in the third century, according to our chronology, a secret mission was successful in penetrating to China, and was enabled to obtain silkworms, and capture, or persuade, four Chinese girls, and bring them to Japan. These girls taught the Japanese the art of sericulture, and the use of silk. From that time the breeding of silkworms and the arts of silk weaving and embroidery, quickly became most important branches of Japanese art and manufacture.

**Introduction of Silk to India.**—Tradition says that at about the same time, 300 A.D., an Indian princess visited China, or a Chinese princess married an Indian prince, and brought to India in her head-dress the eggs of silkworms. She was enabled to teach the management of these valuable creatures to the people of India, so that the weaving of silk soon began to rival the weaving of fine cotton, for which that country had been as famous in the ancient world as was China for the weaving of silk.

**Presentation of Silkworm Eggs to Justinian.**—The Byzantine and Saracenic silk weavers, so many specimens of whose beautiful work are treasured in our museums, obtained their silken threads by unravelling in the manner already described. But in the sixth century, as all historians agree, two Persian monks, who had lived in China and learned the whole art and mystery of sericulture, arrived in Constantinople and

imparted their knowledge to the Emperor Justinian, who deeply interested himself in silk weaving and other arts. He induced the monks, by great persuasion and promises of reward, to return to China and attempt to bring to Europe the materials necessary for the cultivation of silk. They effected this by concealing the eggs of the silkworm moth in a hollow cane. "From the precious contents of that bamboo tube, brought to Constantinople about the year 550 A.D., were produced all the generations of silkworms which stocked the Western world, and which gave trade, prosperity, and untold wealth to great communities for more than twelve hundred years."<sup>1</sup>

B, Plate 3, is reproduced from an engraving in the book of which B, Plate 2, gives the title-page. It is designed to represent the incident of the Persian monks presenting the tube of silkworm eggs to the Emperor Justinian.

**Spread of Sericulture in the East.**—Between the sixth and twelfth centuries sericulture and silk weaving extended over the whole of, what is now called, the Near and Far East; and during all this time a great deal of trading, both in raw and manufactured silk, was done by Eastern merchants, who travelled all over Europe in order to sell their costly wares.

**Introduction of Sericulture to Europe.**—It is probable that the first introduction of the silkworm into Europe was made by the Moors when they conquered the greater part of Spain, and brought their arts and handicrafts to enrich that country, but there is no record of the fact. In the twelfth century, however, there are authentic accounts of the settlement in Italy of colonies of Eastern craftsmen, and the commencement

<sup>1</sup> Dr. S. W. Bushell, *Chinese Art*. National Art Library, South Kensington.

of silk weaving and sericulture, as well as the other arts dependent on weaving.

The domestication of the silkworm in Italy succeeded, and silk weaving flourished. The Italians, like the Chinese, endeavoured to keep the secrets of breeding the silkworm and the preparation of the raw silk to themselves. They were able to do this for about three centuries, but in the sixteenth century it became known in France, and, under royal patronage, became so much valued, that titles of nobility were granted to many of the persons who had been most successful in the business. Kings and dukes became enthusiastic sericulturalists, and royal and noble dames wove silk in the loom. In fact, the art of silk production and silk weaving were there so practised and encouraged, that they reached in France, during the seventeenth and eighteenth centuries, to the highest pitch of perfection they have yet attained.

That success in any art does not depend on the preservation of secrets, but on natural and contributing circumstances, is proved by the fact, that, although there is now no mystery in the matter, China in Asia, and Italy in Europe, still continue incomparably ahead of all other nations in the production of silk.

**Attempts to Introduce Sericulture into England.**—From time to time attempts have been made in this country to introduce sericulture. James I, seeing the success of the French, went so far as to write letters to landowners all over England, advising them to plant and cultivate mulberry trees, with a view to feeding silkworms, but no serious attempts seem to have been made to breed silkworms for profit. This is the more strange, because for a time, silk weaving flourished exceedingly here. The mulberry tree also grows well, and in some parts of the country the young leaves are

ready about the same time as the eggs of the moth are hatched. The difficulty may be with the English peasantry, for sericulture is essentially a peasant industry, and it is possible that the genius of the English peasant is more adapted for fattening pigs and other cattle, and brewing beer, than for delicately feeding and rearing the tender silkworm, preparing its precious cocoons, and reeling them for sale.

But whatever chances there are of sericulture being successfully carried on in this country, there can be no question that in India we are, in our sericultural wealth, more than equal to France, Italy, or any other country in the world, being in some respects better off than China, for we are not confined to one species of silkworm, nor to two. India has the greatest silk-producing fauna in the world, both mulberry-feeding and oak-feeding silk moths abound. As Sir Thomas Wardle says in his interesting handbook on Indian silks, already mentioned : " Her Tusser silk is now an established and well-rooted industry, a few years ago in export non-existing ; her Assamese women are clad in silks of the Eri and Muga worms, of which we, as yet, know practically nothing ; and silken stuffs are handed down from matron to spinster but little the worse for the wear of a generation."

With reasonable care, then, in the breeding and rearing of the worms, and the reeling of silk, in India, and an appreciative fostering of the genius of the Indian people in handicraft ; also the mechanical skill of England judiciously applied, together with the development of better artistic judgment than it has hitherto been characterised by, the silk industry might, with us, as a nation, be carried to a higher degree of excellence, and consequently of greater commercial success than it has ever yet attained to.



FIG. 11. MORUS ALBA—THE CHINESE MULBERRY

## CHAPTER V

### THE PRACTICE OF SERICULTURE

**Requisites for Success in Sericulture.**—Success in sericulture depends mainly on the proper feeding of the caterpillars, cleanliness in all the arrangements for their rearing, and the preservation of an equal temperature in the silkworm house. These matters require unremitting attention from the time the worms are hatched until they begin to spin their cocoons. A suitable breed of worms for the particular climate is also, of course, essential.

**Cultivation of the Mulberry Tree.**—As the best of all silk is obtained from mulberry-fed caterpillars, too much attention cannot be given to the cultivation of the *mulberry*<sup>1</sup> tree wherever sericulture is undertaken. The treatment required for the trees is not such as would be necessary if the mulberry fruit were the object for which the trees are grown, the requirement in this case

<sup>1</sup> There are many varieties of mulberry trees, but the chief are the White Mulberry of China, *Morus Alba*, Fig. 11; the Black Mulberry of Italy, and the *Morus Indica*, the mulberry of India, Fig. 12.

being plenty of large, succulent leaves. The best and largest leaves are obtained from young trees planted out in such a manner as to get the maximum of sunshine and air. Young trees, three or four years old, yield the best crop of leaves, so that a constant succession of trees has to be arranged for. They also have to be fed with plenty of rich manure, in order to develop their foliage as early as possible. About 500 trees will grow advantageously on an acre of ground, and each tree should yield from 20 to 30 lbs. of leaves in a season. 20 lbs. of leaves will feed a hundred silkworms, and from the cocoons of these, weighing about a pound, an ounce and a half to two ounces of best silk can be reeled; the remainders of the silk cases are made into spun silk, which is about half the value of the best silk when twisted up into thread, and the residue consisting of the suffocated insects is waste.<sup>1</sup>

**Wild Silk Cultivation.**—Success with semi-domestic and with wild silkworms must depend largely on the amount of attention that can be given to the business, the more or less suitable kind of trees on which the worms can feed, their freedom from marauding enemies, and the kind of weather which prevails at the time of feeding the caterpillars. The results of these wild silk industries are naturally much less reliable than those of purely domestic sericulture.

The term *oak-feeding*, when applied to silkworms, must not be understood too literally, for the wild caterpillars thrive equally well on the leaves of a great variety of plants native to the places where they are found.

**Silkworm House and Fittings.**—A well-ventilated

<sup>1</sup> M. Pariset, in his admirable work *Les Industries de la Soie*, gives a great deal of information on the growing of mulberry trees and other matters connected with sericulture.



weather-proof house, with arrangements for keeping it at an even temperature, is an essential part of the *menage* of a silkworm farm. It must be fitted up with open shelves in such a manner that all the growing worms may be easily inspected without disturbing them, and so that any which may show signs of disease may be quickly removed.

A quaint but excellent description of the fitting up of a silkworm house is given in the old English book which has already been referred to, and cannot be bettered: "Raise in a convenient, airy room as many shelves, made of dry, wholesome wood, free from strong, offensive smell, as likewise let the whole scaffolding be, as you may judge sufficient for your purpose. Let each of the shelves be a few inches narrower than the one under it, so that if any of the worms should fall off from one shelf, the next may catch them. Let the whole scaffolding stand at some distance from the wall, the better to observe and attend them; also the better to secure them from the rats, mice, cats, poultry, birds, etc., which are their enemies." Such a simple arrangement as the above is quite sufficient for the purpose, but, of course, in Italy and France, where sericulture is a great business, many patent fittings and methods, each one said to be better than the other, are advocated.

**The Best Climate for Sericulture.**—The strongest and finest silk is obtained from cocoons of the species of silk moths, found in temperate climates, which breed only once a year. The cold weather, which prevents the larvæ hatching too soon, also hardens them. A cold winter followed by a genial spring, which coincides with the mulberry tree putting forth fresh leaves, furnishes the most favourable condition for the rearing of silkworms. Even in the multivoltine species, which breed several times in the hot weather of tropical climates, the

first crop of cocoons after the cool weather is invariably the strongest and produces the best silk. With regard to silk produced in countries of different climates, it may be taken as a rule that the silk fibre of temperate climates is distinguished for strength and evenness, while that of tropical ones is soft and bright, but lacking in strength, that is, especially, if produced by domestic silkworms.

**Rearing the Silkworms.**—In a silkworm farm, then, as soon as the mulberry tree begins to bud, preparation must be made for the hatching of the caterpillars. When this occurs, our eighteenth century author says : “ The little worms are to be laid on clean paper, which is to be changed every two or three days, and they are to be fed with clean, young, and dry mulberry leaves, gradually increasing the quantity till they have passed their fourth sickness, and are ready to spin their web or case. They may not be touched with the hand, nor must any person come near them that smelleth of garlick, onions, or any other strong, offensive smell, which caution must be observed at all times whilst the worms are feeding.”

**Formation of the Cocoon.**—When the worms are ready to spin, dry branches and twigs are placed ready for them, and the formation of the cocoons, as described on page 11, begins. It is only necessary to add to that description that, in the words of our eighteenth century author : “ The first day they make a web ; the second day they form their cases in the web and cover themselves all over with silk. The third day they are no longer seen. And the days following they increase the cases always by one end of thread, which they never break off of themselves until their cocoon is finished.”

These simple directions comprise and explain all the essential points in reference to the treatment of the

silkworm from the time of hatching to that of spinning, but much improvement has been made of late years in the treatment of the fibre after it is reeled from the cocoon, and the utilization of the waste silk left after reeling.

**Study of Sericulture in France and Italy.**—Many useful discoveries with regard to the breeding and health of the worms have been made at the government schools of sericulture, both in Italy and France, where all that relates to the welfare of the silkworm and the manipulation of silk fibre is investigated and taught. It still remains, however, that success in silkworm farming depends almost entirely on breeding from healthy moths, cleanliness in the silkworm house, regularity in feeding the caterpillars, and attention to temperature and ventilation.

**The Diseases of Silkworms.**—The diseases to which silkworms are subject are of two kinds, one kind chiefly attacking domestic worms and the other the wild varieties. The diseases of the domestic worms are mostly forms of indigestion, and are hereditary, so that breeding from good healthy moths is of the utmost importance. Domestic silkworms also have an enemy in a parasitic fly, which attacks both the mulberry tree and the worms, and often proves fatal. These have to be carefully watched for on the leaves gathered for the feeding, and on the worms themselves, and, if possible, eradicated. The wild breed of worms are rarely subject to internal disease, but their insect pests and tormentors are very numerous. The prevention and destruction of these would be a useful subject for scientific investigation, but at present little seems to have been done in the matter.

**Eighteenth Century Author on Silkworm Breeding.**—Details of a curious method of improving the breed of



silkworms is given in a *Book of Druggs*, compiled by M. Pomet, published in France in 1745,<sup>1</sup> and translated into English in 1748. It is a good specimen of the wonderful natural history narratives of that period, and is embellished with fine engravings, of which A, Plate 4, is an example. The account M. Pomet gives of the silkworm is as follows: "The silkworms are little insects whose origin is altogether surprising, as well as the various shapes and changes they undergo. Several authors have writ of them, and among the rest a Mr. Isnard, in a little treatise of his, at the 254th page, gives this account of their original: 'At the time when the mulberry leaves are ready to gather, they take a cow, which is almost calving, and feed her wholly on mulberry leaves, without giving her anything else to eat of herbs, hay, or the like. When she has calved, they continue this for eight days longer; after which they let the cow and calf both feed upon this for some days together without any other mixture, as before. They kill the calf, after it has been satiated with the mulberry leaves and cow's milk; then chop it in pieces, to the very feet, and without throwing anything away, put all together—flesh, blood, bones, skin, and inwards—into a wooden trough and set it atop of the house till it is corrupted. From this will presently proceed little worms, which they lay on mulberry leaves to rear them afterwards, just as they do those which are produced from eggs. And these silkworms are abundantly more fruitful than those from eggs, so that those who deal considerably in them, never fail every ten or twelve years to raise them in this way.'"

It would be interesting to know if any purchaser of M. Pomet's book experimented on this method of

<sup>1</sup> Pomet's *History of Druggs*, 1745. Library of Royal College of Science, South Kensington.

improving his breed of silkworms, and, if so, with what results.

**Reeling Silk Fibre from Cocoons.**—The first of the many processes which silken fibre has to undergo, in preparation for use in the textile arts, is reeling from the cocoon. This is a work of great delicacy, and much of the success of the after operations, in which silk is used, depends on this work being properly done

In Europe, at the present time, reeling is for the most part done in factories, so that it is not, as formerly, one of the operations of the silk farm. At the farm the cocoons, after the worms have finished spinning, are fumed or subjected to a degree of heat which kills the creature inside. They are then stored up against the time when the merchant calls who purchases them by weight. The value of cocoons averages about 1s. 6d. per lb.



FIG. 12. MORUS INDICA—THE INDIAN MULBERRY

## CHAPTER VI

### REELING FROM THE COCOONS

**Effect of the Moth Emerging.**—If instead of being fumed, as described in the last chapter, the cocoons are left to themselves, in from twenty-one to forty days, according to the temperature, the moth will emerge from the chrysalis, and, breaking through the silken fibres of its cell, will spoil the thread for reeling off. The cocoon will then only be fit for waste or spun silk. Unless, therefore, the worm or chrysalis be killed, no time must be lost in reeling off the silk. When thus reeled from the *live* cocoon, the silk is found to be more lustrous than is the case when the creature is previously killed. This accounts, in some measure, for the brilliance of Chinese woven fabrics and silk embroideries of to-day, as well as for the superior lustre of much of the raw silk exported from China. Chinese silk farmers still, for the most part, reel their silk from the live cocoons, and it is collected by merchants who travel round the country districts and purchase the hanks of reeled silk from the producers. The same system used to prevail in France and Italy, but in these countries and also, to some extent, now in China and Japan, it has been superseded by the system of factory-reeling. This is in order to meet the requirement of evenness in size, which is so vitally necessary for modern methods of weaving by power. One beautiful quality of silk has, therefore, to be sacrificed in order to make it commercially useful. It is sad to meet at every turn these necessary sacrifices which have to be made all along the line of modern scientifically arranged manufacture.

**Chinese Cocoon Boiling and Reeling.**—B, Plate 4, is another drawing from the Chinese book of sericulture. It depicts the cocoon reeling in a Chinese silk farm, and will do equally well for to-day as for the thirteenth century in which it was drawn. The poem describing the work was written, it is said, by the son of an emperor of the Sung dynasty early in the tenth century.<sup>1</sup> Dr. Bushell has paraphrased it thus :—

“ The scent of cocoons boiling fills the street.  
 The women in each house in busy bands,  
 With smiling faces gather round the stove,  
 And rub together their steam-scalded hands ;  
 They throw the bright cocoons into the basin,  
 And wind out silk in long, unbroken skein.  
 When evening comes they've earned a moment's rest  
 To chat with friends outside the walled lane.”

It will be rightly gathered from this Chinese poem that the cocoons have to be steeped in hot water before reeling. This has to be done in order to soften the silk gum and set the fibre free. The outer web or loose case of the cocoon is brushed away, and then the end of the silk, forming the true cocoon, is readily found. This thread is so fine that thirteen hundred yards weigh only the seventeenth part of an ounce. A thread of such extreme tenuity is of no practical use, so that six cocoons at least have to be reeled together, and their fibres twisted in order to make the finest usable thread. Fig. 13 is a diagram of the simple machine originally used for thus reeling several cocoons together. Although it is primitive, it is perfectly adapted to its purpose, and contains the essentials of all reeling machinery. No. 1 is a bird's-eye view of the machine, and No. 2 is a side elevation.

In No. 1, A A is a small tank, in which water is held and kept by a stove, or some other means, nearly at

<sup>1</sup> *Chine Art.* Dr. Bushell.



boiling point. Into this tank of hot water a number of cocoons are steeped. The side of the tank is shown at A, No. 2.

Above the tank a glass rod is fixed, marked B.  $C_1$  and  $C_2$  are two other fixed bars, having glass eyes at the places marked D D D D in No. 1.

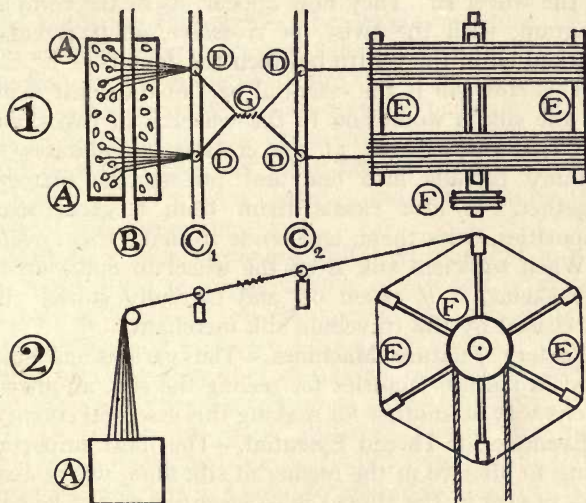

FIG. 13. REELING MACHINE

E E in both Nos. is a pair of skeleton wheels joined together by smooth bars, and suitable for winding silk upon. These wheels are fixed upon one axle, and are caused to revolve simultaneously by means of a strap which runs on the pulley F.

We will suppose the tank to be filled with hot water in which a number of cocoons have been immersed long enough to partially dissolve the gum. The operator finds the ends of fibre on six cocoons at least, draws the six ends together over the rod B, through the eye D in

rod  $C_1$  also through the opposite eye D in rod  $C_2$ , and fixes it to the winding wheel E. She next finds the ends of six other cocoons, passes them over B, through the vacant eye in  $C_1$ , and then twists them several times round the other six threads before passing them through the vacant eye D in  $C_2$ , and fixing them also to the wheel E. They now appear, as in the complete diagram, with the twist, or *crossieur*, as it is called, marked G, in the centre between the four D's.

This *crossieur* is the essential part of the contrivance. As the silk is wound on to the wheel E in two skeins, the twisting together at the crossier consolidates the gummy threads into one and presses the filaments together. It also cleans them from a great many impurities, dries them, and tends to make them even.

When sufficient silk is on the wheel to make up the two skeins, it is taken off and carefully stored until purchased by the travelling silk merchant.

**Factory Filature Machines.**—The various machines, used in filature factories for reeling the silk, all provide in one way or another for making this essential *crossieur*.

**Evenness of Thread Essential.**—The most important thing to observe in the reeling of silk fibre, where evenness of size in the thread is so essential, is the keeping of the same number of cocoons in action. This is where domestic reeling is said to fail. In a factory the reelers are strictly overlooked, and there is trouble if a winder be caught reeling less than the proper number of cocoons. Factory-reeled silk is, therefore, found to be much more reliable as to size than that which is still, as China silk for the most part is, reeled by the silk farmer and his family.

## CHAPTER VII

### SILK THROWING AND WINDING

**Silk Throwing Processes.**—The several winding, twisting, and doubling processes, called *silk throwing*, which the fibre has to undergo before it can be dyed in preparation for weaving, embroidery, or ordinary sewing, will be best described in an account of a visit the author paid to a throwing mill, near London, which has been in operation for over a century, and is still fuller than ever of this interesting work.

**Visit to a Silk Throwing Mill.**—At the first a *book*, the name given to a large bundle of raw silk, white and glistening, weighing several pounds, and containing an incalculable length of reeled fibre, was opened. It consisted of a great number of smaller bundles, or *mosses*, and these again were made up of skeins which had come off the wheels of many different reeling machines. This book of silk had been collected from the silk farms, of several districts in China, by travelling dealers. After being opened it had first to be carefully divided up into separate skeins and sorted into different grades, excellence consisting in freedom from inequalities, such as knots, knibs, or little loose ends of filament. Each skein was hung upon a large, smooth, wooden peg, which looked as if it had done duty for one century and was good for another, opened out, classified, and put, according to quality, into one of the five baskets placed to receive it.

**Washing.**—After being sorted, the silk has next to be washed with a little pure soap. A large, airy room

was shown filled with the washed and sorted silk hanging to dry.

**First Winding.**—The next process shown was the first winding from the reeled skeins on to bobbins. The machines on which this is done are long frames set end-ways to the light, and having both sides fitted up with a series of winding arrangements such as the two depicted in the diagram (Fig. 14, No. 4), one girl being able to

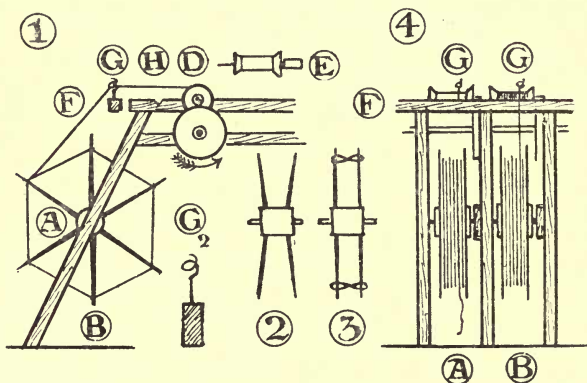

FIG. 14. WINDING MACHINE

superintend the winding of from twenty to thirty skeins at a time.

**The "Swifts."**—The skein is placed on a light skeleton reel called a *swift*. It is made of lance-wood, and so constructed that skeins of various sizes may readily be stretched on it. In the diagram (Fig. 14, No. 1), A, is the swift. It consists of a central wooden core, or cylinder, which moves freely on an axle. In this core six pairs of thin, elastic rods (B) are fixed, slightly inclining outwards from each other, as in No. 2. A

piece of strong, thin cord or wire is looped near the ends of each pair of rods, so as to bring them parallel, as in No. 3. The elasticity of the rods fixes the loops in whatever position they may be placed. These loops, being moved up or down the rods, allow for different sized skeins of silk being stretched on them. Skeins of silk are shown on the two swifts at No. 4, Fig. 14, ready for unwinding.

**The Friction Wheel.**—At Fig. 14, No. 1, distinguished by an arrow, is a wooden wheel, an inch and a half thick having its edges covered with leather. This wheel is kept revolving, by some motive power, at any speed determined on. It revolves in the direction of the arrow. D is a bobbin, shown separately at E, which is firmly fixed on a thick wire axle. At one end of the axle there is a cylinder of lead, which projects from the end of the bobbin, and, when the latter is in position on the frame, rests upon the leather with which the edge of the flat wooden wheel is covered. As the wooden wheel revolves, the weight of the lead cylinder resting upon it causes the bobbin to revolve with it, but *in the opposite direction*. This is called a *friction motion*, and is the only possible one for winding successfully such a delicate thread as silk.

**Importance of the Friction Motion.**—The friction motion is of such importance in all silk-winding machinery, that the reason of the necessity for its use must here be pointed out.

In skeins of such delicate thread as the silk winder has to deal with, the several strands in a skein often get slightly entangled by twisting round each other, or because of a small knot or loop or a slight dampness which renders them sticky. This temporary catch would cause the thread to break, if the bobbin, on to which it was being wound, could not quite easily be

held back by the strength of the thread itself. Any arrangement of pulleys or cogged wheels would not allow of this, but the only resistance to the thread, if a friction motion is used, is offered by the weight of the little cylinder of lead, which rests on the edge of the friction wheel.

**The Sliding Bar and Guides.**—To resume the description of the winding frame, Fig. 14. At F, Nos. 1 and 4 is a bar that runs in front the whole length of the winding frame and has fixed to it, in front of each bobbin, an upright wire which has a twisted end. This is shown enlarged at G<sub>2</sub>.

H is a slot in which the bobbin can rest when taken off the friction wheel for the purpose of mending the thread.

**Winding Procedure.**—Let us suppose that a hank or skein of washed and dried raw silk is placed on the swift as at A, No. 4. The winder finds the end of the thread, and slightly wetting it, fixes it on to the bobbin which rests in the slot H. At the same time she passes the thread into the twist of the guide wire G. She next places the bobbin in the position shown at D, No. 1, with its lead cylinder resting on the edge of the friction wheel, which is revolving. The bobbin immediately begins to turn and wind the silk upon itself, drawing the swift gently round as it does so. Letter B (No. 4) now represents the position. It will at once be seen that another motion is required in order to spread the silk evenly, as it winds, from end to end of the bobbin. This is effected by a motion causing the bar F to move regularly from side to side within the required limits. To provide for this motion, which must be capable of being very exactly regulated, is the most difficult part of the machine to construct. There are many spreading motions in use, but all have some defect to set off against their excellences.

When all the machine is working properly, the winding goes merrily on, and it is astonishing how seldom the tiny threads of silk break and require mending.

**Cleaning the Thread.**—After being neatly wound on to bobbins, which hold several hundred yards of continuous thread, the silk is carried to the cleaning room, where any large knots, ends, or stubs, which may still remain on it, are removed by the contrivance shown in Fig. 15, several sets of which are fixed on a frame similar

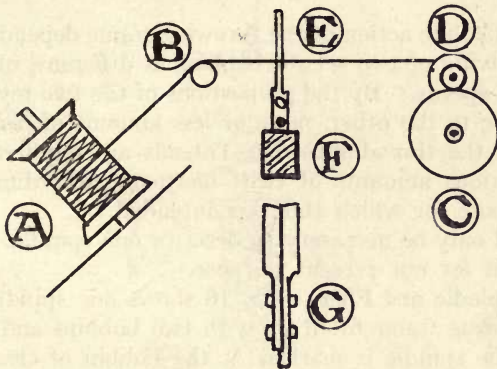

FIG. 15. CLEANING MACHINE

to the winding frame just described ; the only difference between the machines being that the bobbin of wound silk takes the place of the skein on the swift, and that there is an additional fitting E on the guiding bar F. This fitting is a double knife very accurately set, and shaped, and sharpened in such a manner that the silk, as it passes between the blades, on to the bobbin D, is cleaned from all unevenness and hairy filaments. The front view of the knife is given separately at G.

**Throwing (sometimes called Spinning).**—The next process is sometimes called spinning, but more properly

*throwing*. Spinning implies not only twisting the thread, but joining, by means of twisting, numbers of short filaments together into a continuous thread. Throwing, however, merely means the closer and regulated twisting of an already loosely made, compound, continuous thread.

The throwing frame is fitted up with a great number of spindles, to which one person can attend. The work is, however, very responsible, and requires great accuracy so that a very competent mechanic has to be in charge here.

The effective action of the throwing frame depends on the revolving of two sets of bobbins at different, nicely adjusted speeds. By the proportions of the two revolutions, one to the other, more or less amount of *twist* is given to the thread thrown. Threads are required to have various amounts of twist on them, according to the purpose for which they are intended.

It will only be necessary to describe one spindle, and its action for our present purpose.

**The Spindle and Flier.**—Fig. 16 shows one spindle of the throwing frame fitted up with two bobbins and the flier. The spindle is marked A, the bobbin of cleaned silk C, the flier D, and the bobbin of thrown silk E.

The spindle A, between the two bearings B B, is caused to revolve by a rapidly moving leather belt, which presses closely on the whole series of spindles. The bobbin C, on which the thread to be twisted is wound, is firmly fixed on the spindle and moves with it. The *Flier* D has at its centre a small cylinder, which fits loosely on the top end of the spindle, and is kept from flying off by a small screw or button. The cylinder has a groove in it round which a wire is twisted, and then bent into the shape shown in the diagram, and it will be seen that the ends of the wire are twisted into loops or eyes. The bobbin E, which receives the twisted silk,



is fastened to the others of the set, and they revolve steadily all together. The silk from the bobbin C is passed through the eyes of the flier, also through the

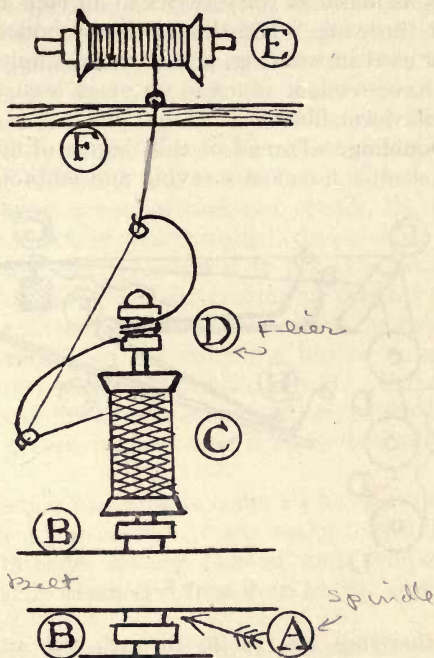

FIG. 16. SPINDLE AND FLIER<sup>1</sup>

eye of the guiding bar F, and so on to the bobbin E. Now, if the bobbin C were loose and the silk were drawn from it on to the bobbin E, it would only be very slightly twisted. But, as the bobbin C is fixed to the spindle, if the latter be made to revolve so quickly that the silk unwinds quicker than the bobbin E receives it, the flier

<sup>1</sup> The length of thread between the two bobbins is about 24".

will carry the thread firmly round and give it as many twists as the differing speeds of the two bobbins make possible. For some kinds of weaving and for sewing silks as many as sixty twists to an inch are given in the first throwing. The thread thus produced is the finest ever used in weaving, and is called singles, although, as we have seen, it is made up of at least twelve strands of silkworm fibre.

**Doubling.**—Thread of this degree of fineness is much too slender for most weaving and embroidery purposes.

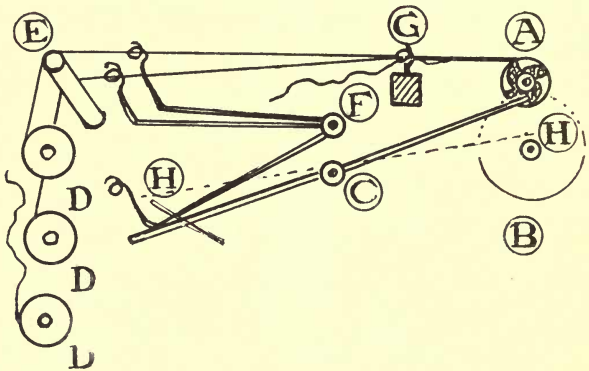

FIG. 17. DOUBLER

It, therefore, has to go through yet another process, called *doubling* or *folding*, that is, winding two, three, four, or more threads together to increase its size and strength. Fig. 17 shows one of the methods by which this is done.

The bobbin A moved, by the friction wheel B, has at the end of its spindle a ratchet wheel, into contact with which the lever C comes, when it is in the position shown in the diagram, and stops it from revolving. The threads to be folded together are on the bobbins

D D D. They are carried over the rod E and each separately threaded through the eye of three bent wires, the wires themselves being loosely fixed to a common centre F. The threads, after passing through the eyes of the bent wires, are carried together through a single eye (G) in the guiding bar, and then on to the bobbin A. As the threads are being wound, the three bent wires will be held up, and the lever C is so balanced that it is normally in the position shown by the dotted line H H. This leaves the bobbin A free to revolve. If, however, a thread breaks or a bobbin runs out of silk, the bent wire, through which it was threaded, drops on to the crosspiece of the lever C, causes it to take the position shown in the diagram, and by coming in contact with the teeth of the ratchet wheel, the lever stops the bobbin.

The folded thread on the bobbin A has to be again thrown, so as to make it solid and compact. This time the twist is given in the opposite direction, which knits the threads together, so that they have no tendency to untwist.

When the second throwing is done, we have a cord of silk, finer than a human hair, made up of from thirty-six to fifty threads, closely twisted and compacted together, perfectly clean and free from knots, loops, or other defects.

**Steaming.**—In order the more firmly to set the twist, or *bead*, as the throwster calls it, the silk is again wound from the small bobbin on to large skeleton reels, which are placed with the skeins on them in a steam chest. When taken out and dried, they are ready for *sizing*, that is, sorting into accurate grades of thickness.

**Sizing.**—The size of silk is ascertained by weighing very carefully a certain length of thread. The specific gravity of silk always being the same, sizing by weight is found to be most accurate and dependable. In

England a skein of 1,000 yards is weighed either in *deniers*, a French weight, or drams.

**Skeining.**—The silken thread having thus been graded for size and quality, it has to be rewound into skeins of uniform length. The usual length, for what is called grant-reeled silk, is now 10,000 yards of continuous thread. The skeins are so ingeniously crossed and laced together that they cannot readily get out of order in handling.

When all these operations are finished, the hard silk, with the gum in it, is ready for weaving fabrics that are to be dyed in the piece, or for the dyer to exercise his art upon.

**The Perfect Thread.**—In the throwing mill we have seen the silk go through the following processes in succession: Sorting, washing, drying, winding, cleaning, throwing, doubling or folding, second throwing, steaming, sizing and reeling, and in all these stages infinite care has had to be exercised in order to produce a perfect thread.

**Historical Note.**—The introduction of silk throwing by machinery into this country is one of the romances of trade. Previous to 1717 the secret of the process itself, as well as the kind of machinery used, was confined to Italy. In that year, John Lombe obtained a patent of the English Government, and started the first successful silk throwing mill. He had secretly gone to Italy and remained there some years working as an ordinary labourer in a silk mill. Being a good mechanic, he learned the secret of the machinery required and the method of treating the fibre. He was discovered, and had great difficulty in escaping with his life. He did escape, however, and built the first silk mill at Derby. He had immediate success, but only lived four years to enjoy it. The business was carried on by his cousin, who afterwards

became Sir Thomas Lombe, and the possessor of a great fortune. John Lombe's death is said to have been due to poison given to him by a woman who followed him from Italy, but whether her motive was public or private vengeance, has never been ascertained.

Other silk mills were founded during the eighteenth century at Southport, Macclesfield, Congleton, Leek, St. Albans, and many other places, and most of them are still working. It is gratifying to know that, although other countries produce the fibre, English manipulation of it is unrivalled.

**Spun Silk.**—Before leaving the subject of the preparation of silk thread, it is necessary to mention *spun silk*, which is a very useful and beautiful thread, and from which many most artistic and durable fabrics are to be made at a cost of about half the price of best silk. It is made from the waste silk covers of cocoons, from cocoons out of which the moth has broken its way, or of any raw silk, which for some reason or other cannot be reeled off. It is made also from the fluff and cleanings which are gathered from the best silk as it passes through the throwing mills. In fact, all the waste silk of whatever kind is collected together, torn to filaments, and spun in the same way as cotton fibre, a process, it would occupy too much space to describe here, and, in fact, it belongs to the subjects of cotton, wool or linen, all of which fibres are spun, or joined up into thread, in the same manner as spun silk.<sup>1</sup>

<sup>1</sup> A description of Cotton Spinning will be found in the volume of the series dealing with Cotton.

## CHAPTER VIII

### SILK DYEING

**Yarn and Piece Dyeing.**—The next step, in the preparation of silken thread for use, is that of *dyeing*. This is done while the silk is in skeins, when it is to be used for embroidery, sewing, or best weaving. Many cheap kinds of silk fabrics are woven “in gum,” that is, woven of unboiled silk. In such cases the woven material is boiled and dyed in the piece.<sup>1</sup> Yarn-dyeing has, however, many advantages, and the great bulk of silk goods are woven of yarn-dyed thread.

Wherever done, to any great extent, the process of dyeing silk, whether in ancient or modern times, is very similar. It will be best, therefore, now briefly to describe the procedure of a modern dyer dealing with an ordinary parcel of silk. Machinery is not, to a great extent, used in dyeing, except where very large quantities of yarn have to be dyed of the same colour, but the drying of the skeins, after dyeing, is now generally done by means of the hydro-extractor, to save time.

Previously to being dyed, the skeins of silk have to be boiled, in order to extract the gum. Before being boiled, silk is harsh and wiry, rather like fine horsehair. It also frequently has some colour of its own. Italian silk is yellow, Chinese and Japanese semi-wild silk is light fawn colour, Indian wild silk is darker fawn colour, Chinese best silk is nearly white, and so on; but the boiling extracts the colour, with the gum, and leaves the

<sup>1</sup> Piece dyeing is now carried to a high pitch of perfection, the threads of warp and weft being chemically treated before weaving, so that each is only sensitive to a certain range of colours. This makes it possible to piece-dye shot effects, a proceeding which had hitherto been thought impossible.

silk soft, white, and lustrous. It also reduces the weight considerably. Sixteen ounces of silk are reduced to twelve, more or less, by the boiling.

In order to boil the silk without injury, the skeins are carefully loosened and tied in convenient bundles with a smooth cord. They are then packed in soft muslin bags, and immersed in water in which a quantity of dyer's soap has been dissolved. Heat is then applied to the copper, in which the silk is placed, and the water is allowed to boil gently for about two hours. When sufficiently boiled, the bags are taken out of the liquid, the silk is loosened, and rinsed thoroughly in cold water, in order to free it from the gum and soap. When this is done, it is ready for dyeing. The soap and water, with the gum in solution in which the silk has been boiled, are kept for use in making up the colour or dye bath.

Until the introduction of aniline dyes, which are not worthy to be used on silk, the only kind of dyes known were those extracted directly from natural vegetable and animal substances. Now, however, the *alizarine* dyes, which are practically the same as the natural ones, as regards colouring matter, are mostly, and should be always, used for the best silk. The process of dyeing with either the natural or alizarine dye-stuffs is the same, and it is this process which is about to be described.

**The Dye-house.**—A dye-house requires to be light and spacious. Its floor must be of stone or concrete, and be made slightly sloping, so that the floods of refuse dye liquid may flow off quickly when emptied from the tanks or *barcs* which stand in all parts of it.

It must also have a system of steam pipes, from which jets of high-pressure steam can be injected to any of the *barcs* at will.

It has also to have coppers fitted up, in which the

silk can be boiled, also several large wooden pegs, very strong, smooth, and hard, fixed very firmly to the walls. There must also be sundry racks for hanging parcels of silk, divided up into skeins, upon. There must also, of course, be plenty of water—soft or river water in preference—available.

**The Dye Barc.**—The most noticeable objects in a dye-house are the great barcs, of various capacities, which stand about the floor, and in which the silk is dyed.

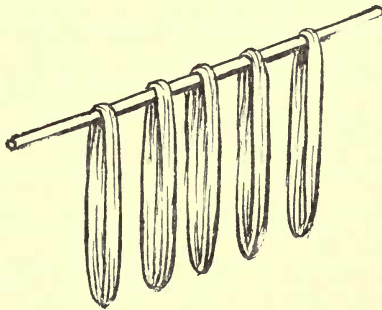

FIG. 18. DYE STICK

The barc is a tank, usually made of thick copper, and is about two feet wide and two feet deep. Barcs vary in length from three, to seven or eight feet, so as to accommodate different quantities of silk that are to be dyed.

**The Dye Sticks.**—The dyer has to be furnished with a large number of round, smooth, hard wood sticks, about three-quarters of an inch thick, and two feet eight inches to three feet long.

**Position of Skeins for Dyeing.**—The skeins of silk are placed on these sticks, as shown in Fig. 18, and when the sticks with the skeins on them rest on the edges of the barc, which has previously been nearly filled with



liquid dye, as shown in Fig. 19, the skeins are about three parts immersed in the dye.

**Turning the Skeins.**—The method of turning the skeins in the dye is as follows: The dyer pushes all the sticks to one end of the barc, and, standing to the left of it, he takes the end of the first stick in his left hand, pushes it away from the others, and holding it very firmly, he, with his right hand, takes the skein, where it rests upon the stick, raises it to the position shown

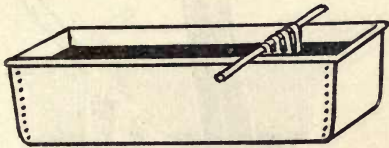

FIG. 19. DYE BARC

at Fig. 20, and then gently drops the undyed end into the liquid, thus reversing its position on the stick. All the silk on the first stick being turned, it is pushed to the opposite end of the barc (Fig. 21), and the next stick and all the following ones are taken in succession, the skeins turned in the same manner, and pushed close up to the opposite end of the barc. The dyer now goes to the other side, and proceeds in the same manner to work the sticks back, and so backward and forward until he deems they have taken up enough dye.

**The Mordant.**—This, so far, explains the mechanical process, but before being put into the dye, the silk has to be *mordanted*, in order to cause it to take the dye thoroughly and evenly. For mordanting, the silk skeins are hung on sticks as for dyeing, but are securely tied to them. They are then entirely immersed for some hours in a barc or other vessel containing a solution of certain chemical salts, which vary according to the

colour to be dyed. In fact, some dyes are entirely changed in colour by the particular mordant used.

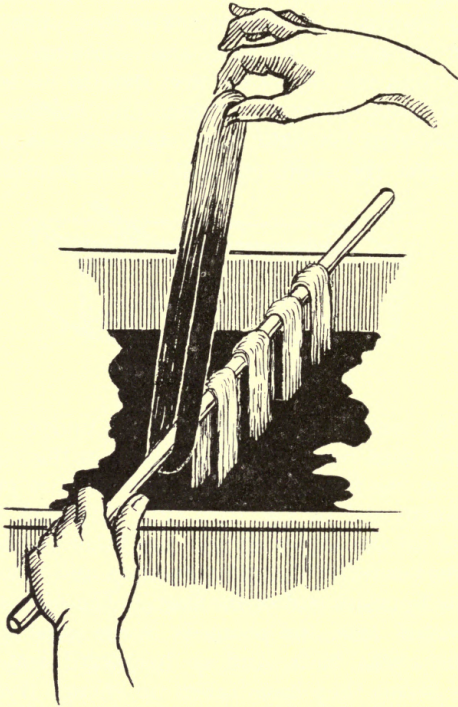

FIG. 20. TURNING THE SKEINS

When sufficiently saturated with the solution, the silk is taken out, rinsed in clear water, and is then ready for dyeing.

**Process of Dyeing.**—For dyeing, the barc is almost filled with water, in which the silk has been boiled, and

the dye-stuff is added to it. It has to be, of course, thoroughly mixed before the silk is put into it. When ready, the sticks, with the mordanted skeins on them, are put into position, and the dyer begins at once to turn them, as already explained. When the silk is thoroughly saturated with the cold liquor, steam is injected and the dye is slightly raised in temperature. The dyer goes on turning the skeins and gradually works the liquid up, between each round of turning, to boiling point.

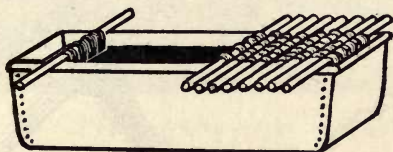

FIG. 21. DYE BARC IN USE

As soon as he thinks the colour is strong enough, he lifts the sticks out of the barc, rests them on a rack, and, taking off one skein, wrings it out and takes a trial by drying a few threads. He usually finds that the colour is less strong than he thought, and has to replace the silk in the barc and continue turning it in the hot liquid, or, it may be, he has to add more dye, or modify the colour in some way. If it be right in colour, the silk is rinsed in clear water very thoroughly, in order to remove any loose dye, and then, after draining for a little while, is ready for the next process, which is *wringing*, or *scrouping*; as it is sometimes called.

**Wringing or Scrouping.**—This wringing appears to be a very severe process for such a delicate thread as silk. But by it the glossy lustre of the silk itself is very much enhanced. The dyer takes a wet skein and, hanging it on one of the strong wall pegs (Fig. 22), puts a strong, smooth stick through it, and twists it up, as shown in

the diagram, with all the force he can use. He twists and wrings it first one way and then the other, until the silk is nearly dry, and he can squeeze no more liquid out of it. He now takes another test for colour, and, if he

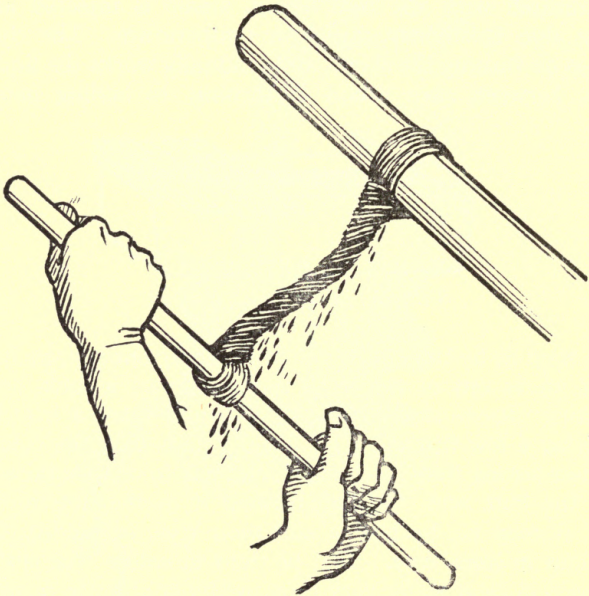
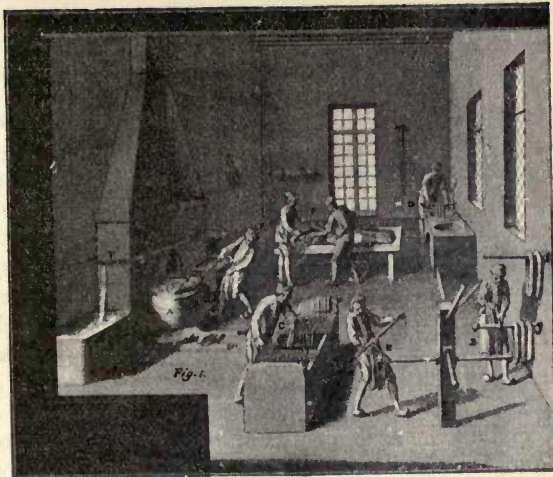

FIG. 22. WRINGING

passes it as correct, the whole parcel of silk is wrung in the same way, and then sent to be dried, either in a drying room or by the hydro extractor.

**Indigo and Cochineal.**—For particulars as to indigo and woad vat dyeing, the dyeing of crimsons and scarlets with cochineal, and all the various dye-stuffs



A, PLATE 5. A FRENCH DYE-HOUSE, 18TH CENTURY  
(See p. 56)  
(National Art Library)



B, PLATE 5. A MEDIÆVAL DYER. (See p. 56)  
(National Art Library, South Kensington)

in general use, the reader should consult such authors as those named in the note below.<sup>1</sup>

An interesting view of an eighteenth-century French dye-house is given at A in Plate 5.

**Miserable Condition of Some Mediæval Craftsmen.**—Plate 5 (B) is photographed from an English manuscript of the fourteenth century. It represents a silk piece-dyer, of the period, about to dye a woven web of a diaper pattern of the kind, which it will be shown later on, were specially woven at that time in England, as grounds for embroidery. The craftsmen of to-day are sometimes inclined to complain of their lack of comforts and luxuries, but, if this picture fairly represents the condition of the silk dyers of mediæval times, the craftsman of the present time may, at any rate, congratulate himself that he is better off than his predecessors in the fourteenth century. It may be supposed however, that the set of pictures, in this old book are rather symbolic than actual, for all the workers in the drawings, whether working indoors or out, are depicted in the same plight as to clothes; whilst their pastors and masters ride on horses and mules, clothed in gorgeous raiment, and evidently faring sumptuously every day.

It will be noticed that the dye pot, in the drawing, is heated by a blazing fire below it. This was the method in use before steam was generally adopted in the eighteenth century.

**Old French Silk Books: their Sumptuousness.**—The picture of the dye-house at A, Plate 5, is from a fine old French book of the eighteenth century on the art of dyeing, and represents a well-furnished dye-house. All

<sup>1</sup> *Art de la Teixture en Soie*, per M. Macquaic, 1763. *Art of Dyeing*, M. Hellot, Dublin, 1767. *The Dyer's Guide*, Thomas Packer, London, 1830. *Handbook of Dyeing*, W. Crookes. (Longmans, London, 1874.)

the work is shown going forward, as described above, except that the dyer, at the barc, is turning the skeins with his left hand.

The high estimation in which the art of manipulating silk was held in the seventeenth and eighteenth centuries is evidenced by the magnificent and costly books on the subject, such as the one from which Plate 5 (A) is taken, which were published in France at that time.

**Old Laws Regulating Dyeing.**—The dyeing of silk and other goods used to be regulated by law. The permanent and fugitive dyes were called *great* and *little* dyes. Only common goods were allowed to be dyed by the lesser dyers, and all goods, above a certain value, were dyed by the great dyers and had authorised marks upon them.

The following extract, from an old English translation of a French dye book, is interesting, as it applies equally to the alizarine and aniline dyes of to-day :—

**Extract from Old Book on Great and Little Dyes.**—“It may appear extraordinary that as there is a method of making all colours by the *good* dye, that the use of the *lesser* dye should be tolerated ; but three reasons make it difficult, if not impossible, to prevent the practice : (1) The work is much easier : most colours and shades which give the most trouble in the great dye are easily carried out in the lesser ; (2) most colours in the lesser are more bright and lively than those of the great ; (3) for the reason, which carries most weight, the *lesser* dye is much *cheaper* than the *great*. This is sufficient to determine the workmen to do all in their power to carry on this dye, in preference to the other. This engaged the French Government to constitute strict laws in regard to the distinction between the great and lesser dyes.”<sup>1</sup>

<sup>1</sup> See Hellot's *Art of Dyeing*. National Art Library, South Kensington.

**Classification of Dyes.**—The test required for classification in the great dye class was: Twelve days' exposure to the summer sun and the damp air of night. If the dye stood this test, there was no doubt as to the class under which it should be ranked.

The subject of *dye-stuffs* for silk is a tempting one, but would require a volume to itself. All that must be said here is that, unfortunately, most modern chemical research has been made in the direction of variety and brightness of colour, together with cheapness and easiness of working, rather than in that of permanence and real beauty of colour.<sup>1</sup>

**Re-winding of Dyed Silk.**—The skeins of silk having been dyed and dried, have next to be re-wound on to bobbins of different sizes and shapes, according to the purpose for which the thread is to be used.

<sup>1</sup> For further information as to dyeing and dye-stuffs, the student may refer to the works already mentioned and many others. It must, however, be borne in mind that the modern writers, for the most part, deal only with the aniline dyes.



## CHAPTER IX

### VARIETIES OF SILK THREAD

**Varieties of Twist in Silk Thread.**—Silk thread is prepared for use, in the different departments of textile industry, chiefly by being twisted more or less closely in the throwing and spinning processes. These are capable of immense variety, and the throwster lays himself out to suit his customers with the particular amount of twist they may desire. A great deal of twist on a thread means a strong, hard, but comparatively dull one; whilst little twisting results in a bright, soft, flossy thread.

**Hard Silk.**—When the silk leaves the throwing mill, it has the requisite twist, should be thoroughly cleaned of all unevenness, and be of ascertained size. But it is still called hard silk, that is, it retains the silk-gum. In this state it is sold to the manufacturer, who orders its further treatment to suit the purpose for which he has purchased it.

One use to which cleaned and thrown singles are put is the weaving of webs from which the sieves of flour-milling machinery are made. This sieve silk is most carefully and exactly woven, in more or less open textures, for sifting the flour as it passes from one stage of fineness to another, in the mill.

**Hard Silk Webs.**—Hard silk is also now used largely in weaving fine gauzes and the cheaper kinds of plain umbrella and dress silks. These are boiled off and dyed, after being woven, by the piece dyer. The advantage of weaving the hard silk is that the gum strengthens the thread, which would otherwise often be

too fine and tender to bear the strain of stretching in the loom.

**Balloon Silk.**—Silks for the gas envelopes of balloons and airships are made of boiled, but undyed, thread, on account of its strength and lightness. The material for this purpose, after being woven, is waterproofed, which renders it air-tight and impervious to wet.

**Organzine and Tram.**—Two kinds of finished silk thread, whether dyed or undyed, are used in general weaving: these are called respectively *Organzine* and *Tram*. To the organzine a great deal of twist is given in the throwing, which makes it hard and strong. Organzine is used for warps, which are the longitudinal threads of a web, and are tightly stretched in the loom before weaving begins, hence the name *warp*, which means to bend or stretch. Great strength and regularity are requisite in the warp threads, in order that they may bear the strain and friction of weaving, as well as that the weaver may not be hindered in his work by breaking threads. Tram has much less twist given to it than organzine, and is consequently soft and more or less *flossy*. Tram is used for woof, weft, shute, or filling, as it is indiscriminately called. All these names signify the intersecting thread which knits the warp together into a web of cloth. There is little strain on the weft, but it is necessary that it should be soft and bulky, in order that its successive threads may lie close together and fill up the interstices of the web.

With the exception of spun waste silk, varieties of organzine and tram are practically the only kinds of silk thread used for weaving; and the only varieties in each sort are difference of size, amount of twist, and quality of silk.

**Sewing and Embroidery Silks.**—For sewing, embroidery, and trimming purposes, however, all kinds of

twists and plaitings, and an immense variety of sizes are used ; from almost twistless floss to the hardest and strongest thread it is possible to make, with often several hundred strands of fibre closely twined together.

**Brocading Metal Threads.**—For weaving rich *brocaded* silk webs and also for gorgeous embroidery, silk is often covered, or partially covered, with a twist of gold or silver wire, or with gilded strips of parchment or paper. For this purpose very little twist is given to the silk itself, so that the metal or paper clings to it, and it becomes a homogeneous thread. The seventeenth and eighteenth century weavers in Italy and France were particularly skilful in weaving with these metallic wefts.

## CHAPTER X

### ANCIENT SILK WEAVING

**Art of Weaving Prehistoric and Universal.**—Weaving, the art of intersecting threads so as to make cloth, is prehistoric, and seems to be instinctive to mankind. Specimens of it are to be found amongst the relics of the people of the Age of Stone, and there is no tribe of man, however primitive, which has no knowledge of, or does not practise textile art in, one form or another.

By all the great nations of antiquity—Egypt, China, India, Greece, and Rome—weaving was carried to a high degree of perfection. That perfection, however, was not attained by the use of elaborate machinery, as some authors have imagined, but by the patient manipulation of multitudes of threads arranged in order on simple frames.

**Weaving Technique.**—The most intricate pattern web only consists of two sets of threads, the warp and the weft, intersecting each other in different proportions. Roughly speaking, the effect is the same, whether the threads are simply stretched in order on a rude frame and picked up and intersected by patient handwork, or set up and arranged in a complicated machine, so constructed as to lift and intersect the threads automatically in the necessary combinations for the weaving of the web and its ornamentation. The former is the ancient method, and the latter the modern one.

**Characters of Ancient and Modern Technique.**—Although almost anything that can be woven, either by the ancient or modern methods, is possible in both, each kind of technique gives facility for a different class of intersection, which it is necessary to understand clearly.

**Ancient.**—The frontispiece is a fine specimen of the ancient method of manipulation. The tiny threads of warp, about eighty to an inch, were all selected and raised for the formation of this design, and the various coloured pieces of weft were inserted, without the aid of any mechanical contrivance whatever. When the *weft* thus chiefly shows in a design, weavers call it a



FIG. 23. TAPESTRY WEAVING

*weft effect.* In such weaving the warp only acts as a foundation to, or a tie for, the ornamental weft. In this example the warp is entirely covered by the weft, and the pattern is really a *mosaic* of small pieces of plain weaving in which different coloured wefts have been used. *Tapestry* is the name given to this kind of weft effect weaving (see Fig. 23). Sometimes the ancient weavers only treated a portion of the web in this manner,<sup>1</sup> but whether more or less covering the warp,

<sup>1</sup> Many examples of tapestry-woven ornamental webs of the Egypto-Roman period may be seen in the collection of textiles at the Victoria and Albert and the British Museums, London.

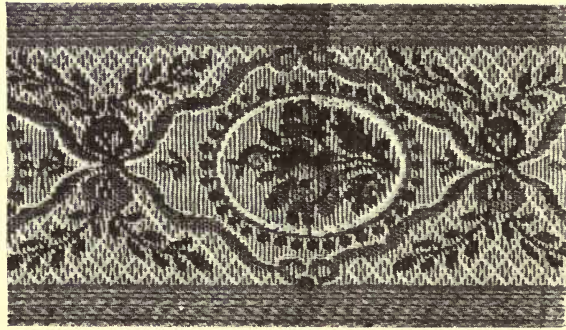

A, PLATE 6. POWER-LOOM  
TISSUE (MODERN). (See p. 65)



B, PLATE 6. CHINESE IMPERIAL ROBE. (See p. 73)  
(Victoria and Albert Museum)

the ornament in ancient weaving was, without exception, formed by the wefting.

**Modern.**—A, Plate 6, was photographed from a piece of modern power-loom pattern weaving. In this example the effect is got by the use of two or three warps of different colours working together, and by striping one of them with different coloured threads. The design is brought out by raising these coloured warp threads, as they are required for the pattern, and leaving them in loops above the weft. The insertion of the weft is thus rendered quite simple and regular, and the stuff, when the design is once arranged for in the machine, is as easy, if not easier, to weave than it would be if the web were quite plain. This is a *warp effect*. It is comparatively a modern method of pattern-weaving, and is particularly suitable to the power-loom.<sup>1</sup>

**Materials Used in Weaving.**—For the most part, the materials in use to-day for weaving were also used by the people of antiquity. The weaving of each kind of thread was, however, restricted to different nations. The Egyptians used flax, and the fine linen of Egypt was the admiration of the world. The natives of India used cotton for weaving, the cotton plant being peculiar to that country. The nomadic and pastoral tribes made cloth of the hair and wool shorn from their flocks and herds, and the Chinese had, as has been already pointed out, the monopoly of silk for very many centuries.

**Chinese Use of Silk.**—It was only natural that the Chinese, thus having the monopoly of the finest and

<sup>1</sup> For full descriptions of these and all methods of weaving to be afterwards referred to, see the author's book, *Hand-loom Weaving: Plain and Ornamental*, published by John Hogg, London.

most beautiful of all threads, should early devise methods of weaving it which would show it off to the best advantage. Ordinary plain weaving with which the Chinese, in common with all primitive people, began the manufacture of textile fabrics, would not do this. The most lustrous silk fibre, if woven in the plain and simple way called *tabby*, *taffeta*, or *sarcenet* (see Fig. 24),

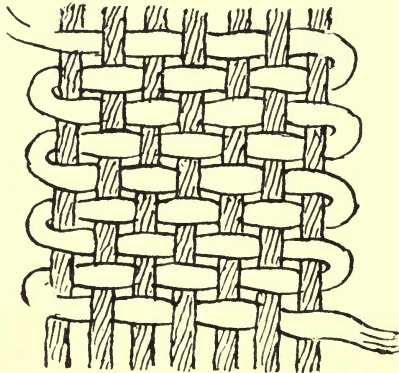

FIG. 24. TABBIE WEAVING

appears dull, both in lustre and colour, if compared with a loose skein of the silk of which it is made, especially if the weaving be well and closely done.

**First Step in Automatic Weaving.**—At this point it becomes necessary to give a brief description of the mechanism of the parts of the loom which have to do with lifting the threads of the warp for the intersection of the weft. In the most primitive looms this is simply done by means of the weaver's fingers, but very early in the history of weaving an automatic arrangement was devised, so that, for plain webs, the weaver could, with his feet, by means of a system of treadles, lift the



threads in the required alternation, and thus leave his hands free to intersect them with the weft. By this contrivance much time was saved.

It is impossible to say where this invention was first used ; but as silk, being so fine, would be the most difficult and tedious thread to pick up with the fingers, a needle, or other implement, it is most probable that the Chinese were the originators of this important step in automatic weaving. Fig. 25 will serve to explain this contrivance. At A is a warp of eight threads, stretched horizontally between the back and front rollers of a loom of some form—what form is immaterial. Near the letter A is the front roller of the loom, on to which the cloth is wound as it is woven. The weft is shown, next to the roller, loosely intersecting the warp. At B B the main part of the warp-thread lifting appliance is shown. It consists of four laths joined together in pairs. Each pair has one lath above, and one below the warp. The laths are joined together in pairs by four strong double threads, made in three loops, as shown at C. The centre loop is quite small, and through this the warp thread is passed. A glance at the drawing will at once make clear, that, through the centre loops of the front *headle*, for that is the technical name of the pair of laths, the first, third, fifth, and seventh threads of warp pass ; also that the second, fourth, sixth, and eighth threads pass through the back headle loops.

Above the headles a roller or pulley (D) is fixed, and a cord from the front headle passes over it and is attached to the top of the back headle.

The bottom laths of the headles are joined separately by cords to a pair of treadles (E).

Now, if the weaver, sitting in the loom, presses down one treadle, four of the warp threads will sink, with the headle to which they belong, as it is drawn down. This

SILK

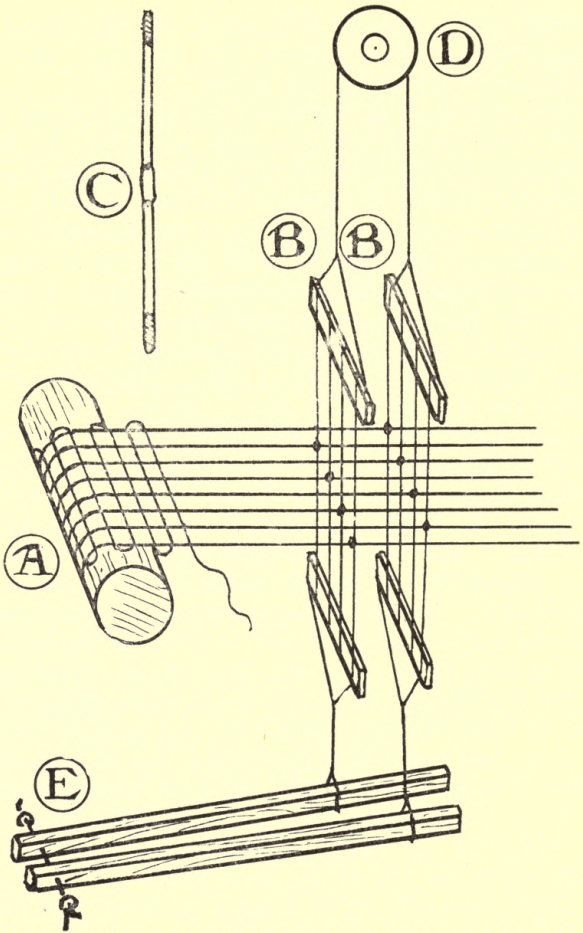

FIG. 25. HEADLES FOR OPENING THE WARP OR SHED

will also draw down the cord which passes over the pulley D, and in consequence raise the other headle

with its warp threads. There will now be an opening, in front of the weaver, through which to pass the weft. Then, by pressing down the other treadle, the position of the warp threads will be reversed, and the second opening necessary for the return of the weft will be ready. This is the simple contrivance by means of which the warp threads, no matter how many there be, are automatically opened for plain weaving.

**Invention of Satin Weaving.**—There is no record of the time when the method of weaving was invented by the Chinese, which gave a full display of the lustre of the silk, which is its chief beauty. But there can be no doubt that they were the inventors, and that probably they devised this system of weaving many hundreds of years before the Christian era.

This process is called *satin* weaving, and it is remarkable as being the foundation process in all modern pattern weaving, whether simple or complex.

**Satin Web Intersection.**—A comparison of Figs. 24 and 26 will show the difference between the interlacings of plain or tabby weaving and those of the satin. In the tabby (Fig. 24) the weft passes alternately above and below the individual threads of the warp. But in the satin web (Fig. 26) the weft passes over *one* thread and under *seven* of the others. Also there are eight different lines in the weft completed before one exactly similar to the first is repeated. Thus in the first line the first warp thread is raised ; in the second, the fourth thread ; in the third, the seventh ; in the fourth, the second ; in the fifth, the fifth ; in the sixth, the eighth ; in the seventh, the third ; and in the eighth, the sixth thread is raised. So that whether counted vertically or laterally, there are always an equal number of spaces between the intersections of satin *ties*, as they are called. By this clever arrangement almost all the warp is brought

to the front surface of the web, and the same proportion of weft is left at the back. By this method of intersection,

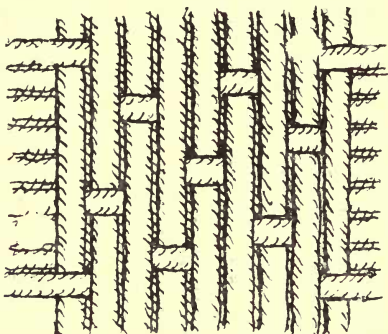
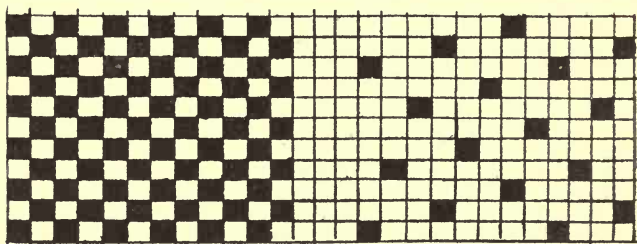

FIG. 26. SATIN WEAVING

too, the ties are hardly perceptible, and the surface presents, when the web is woven of silk, the sheeny, smooth appearance which is characteristic of satin.



①

TABBY.

FIG. 27.

②

SATIN.

Nos. 1 and 2 (Fig. 27) indicate how the intersections are expressed on designer's ruled paper, and should be

compared with Figs. 24 and 26, as such matters will now be more readily illustrated in this manner. It will be noticed in Fig. 27 that weft is expressed by filling in a blank space, and warp by leaving a white space on the paper.

It must not be supposed that satins are always constructed on eight threads; they may be woven on

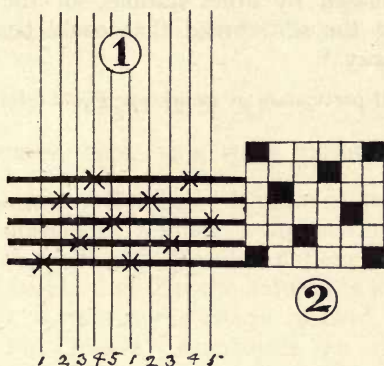

FIG. 28.

almost any number, from five to twenty-four, but satins of *five* and *eight* threads are the most usual.

**Illustration of Satin Technique.**—Satins also require as many headles, in order to weave them, as their number of intersections indicate, and are called *five-headle* or *eight-headle* satin, as the case may be. Fig. 28 (Nos. 1 and 2) will explain this point. In No. 1 the thin, vertical lines are the warp, and the thick cross lines represent the headles. The ticks on the crossings of the two sets of lines show the order in which the headles are raised in weaving. No. 2 is the sketch of a five-headle satin on ruled paper.

It is not surprising that the fine, lustrous, and

exquisitely dyed silken webs of China should have been coveted, and bought for fabulous prices by the luxurious people of ancient Greece and Rome, as the many references to them in classic literature show that they were. So that ancient China is known to have done a large export trade in rich and finely woven webs, as well as in the simpler ones, which, as has been already noticed, were purchased by other nations for the purpose of unravelling the silk thread that could be obtained in no other way.<sup>1</sup>

<sup>1</sup> For full particulars of satins, see *Hand loom Weaving*.



FIG. 29. DRAGON, FROM AN ANCIENT CHINESE PAINTING

## CHAPTER XI

### THE ORNAMENTAL SILK WEBS OF CHINA

**Ancient Ornamental Textiles.**—It cannot be doubted that the decoration of textiles began in China in the same manner as with other ancient nations, that is, by means of the needle, and that the darning in of separate ornaments, in the tapestry or mosaic method, was early adopted by the Chinese. Afterwards the whole webs were no doubt woven in the way described on pages 63, 65, and 66. This kind of weaving cannot, however, be done on satin grounds, nor does silk lend itself so kindly to manipulation in tapestry as do wool and linen. The Chinese, nevertheless, do marvellous things in pure tapestry weaving, even in silk. An example of this is given by a Chinese Imperial robe of pure tapestry mosaic, now in the Victoria and Albert Museum, from which B, Plate 6, is taken.

This robe was woven on an Imperial loom, and must have taken an enormous amount of time to make. The weaving is most minute and exact; all the forms of ornament are perfect in drawing, and the colour is superb. Nothing finer can be imagined either in craftsmanship or design. But, although this robe is such a

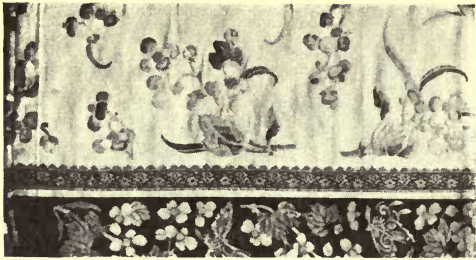

A, PLATE 7. CHINESE SATIN WITH  
EMBROIDERY. (See p. 75)  
(Victoria and Albert Museum)

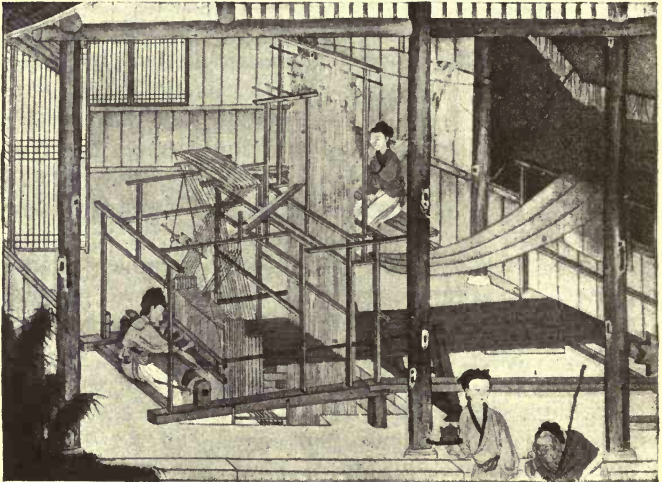

B, PLATE 7. CHINESE DRAW-LOOM. (See p. 76)  
(Victoria and Albert Museum)



perfect piece of work, its method of weaving renders it impossible for it to display the lustre of the pure silk of which it is woven.

The satin grounds, described in the last chapter, were particularly suited for displaying to advantage the embroideries of silk and gold, which the Chinese have always been so skilful in working, and it is certain that the decorated textiles of ancient China were at first either tapestry mosaics, or embroidered satins.

A, Plate 7, is also from a portion of an Imperial robe. The whole garment is made in rich satin embroidered in coloured silks. It also has narrow tapestry-worked borders, with fine details *painted* in. The part shown is the sleeve of the garment, which is a beautiful example of Chinese needlework on satin. ) k'o-ssu

It is said that Chinese textile designs can be traced back to very ancient times by means of representations of them on more lasting decorative materials, such as enamels, porcelains, etc. There are also innumerable references in Chinese classical books to woven and embroidered designs on flags, banners, official robes, Imperial paraphernalia, and the like.<sup>1</sup>

**Ancient Records of Ornamental Weaving.**—Ancient Chinese historians often referred to woven and embroidered silks. For instance, the Chinese emperors gave gifts of rolls of figured silks, as at the present day. This is proved by the citation of a notice of the presentation of five rolls of silk brocade, with dragons (Fig. 29) woven in gold upon a crimson ground, by an emperor in the year A.D. 238, to the reigning Empress of Japan, who sent an embassy to the Court of China in that year.

The names of traditional designs for silk fabrics,

<sup>1</sup> Dr. Bushell, in *Chinese Art*, gives long lists of these ornaments and designs.

which are constantly referred to in Chinese literature, are perfectly in keeping with those which the Chinese silk weavers and embroiderers use to-day. The Chinese craftsman does not concern himself about *originality*, the curse of modern art, but just goes on producing, with little variety, the same kind of pattern, with the same quality of technique which his ancestors did centuries ago. This impassiveness tends to perfection, but makes it very difficult to determine with certainty the date of anything Chinese, unless it be characterised by something other than style of design and method of craftsmanship.

**The Loom for Pattern Weaving.**—At what period in Chinese history the loom, used for the automatically weaving of elaborate patterns, was evolved it is impossible to say; but there can be no doubt that it was many centuries before the Christian era. And also, that to the Chinese the credit is due for the invention of that marvel of ingenuity, the *draw-loom*.

A representation of a highly developed draw-loom is given in the old Chinese book to which reference has already been made. It is the original of B, Plate 7.

Such an advanced form of pattern weaving machine must have taken many generations of Chinese weavers to perfect, for, although the picture is of the thirteenth century, it might be taken as a representation of a Chinese pattern weaving loom of to-day, no improvements having been made since that time. From a careful examination of the Plate much can be learned of the mechanism of this most important and interesting of all silk-weaving looms, the *compound draw-loom*.

The first thing to observe is that the loom is a double one, and that two weavers are at work on it. One of these is seated in front of the loom in the ordinary

position of a weaver, evidently weaving cloth. The other is perched aloft at the back like a *Deus ex machina*, busy about some department of the work, the purpose of which is not so clearly evident.

The lower front portion of the loom is very similar in construction to an English or French hand-loom, such as is used for weaving the best plain silk fabrics at the present day. There is the warp, of extraordinary length in this case, stretched between the front and back rollers of the loom, also the headles with their loops or leashes for lifting the warp threads, and the levers and treadles by means of which they are governed.

The number of headles in the harness depicted is eight, so that the weaver is making a web, the ground-work of which is no doubt eight-headle satin. There is another set of headles indicated immediately behind the first set, but as these are not in use, as indicated by the unstrung set of levers to which they are attached, they need not be considered. All this part of the loom the weaver in front can manage by himself by means of the treadles, which may be seen in the hollow space, in the floor of the weaving-house, just below the loom.

Now the perched up figure at the back of the loom claims attention, for it is in him and his work that the peculiarity of the draw-loom is found. The cloth spread below him is for the purpose of protecting the precious silk warp over which he is seated. Immediately in front of him a tall frame is placed, and a system of fine cords, hanging from the top, pass through a board at its centre, and after going, as it appears, between the threads of the warp, pass into the pit below the loom, and there their termination is hidden from view.

There is no indication, in the drawing, of the manner in which the back portion of the loom is worked by the presiding genius, but the effect of it is just shown on

the warp immediately in front of the weaver, who sits below. Little groups of threads are seen to be raised, and it is in managing these that the second weaver is engaged. This will be understood clearly after the explanation of the principles of the simple and compound draw-loom contained in the following chapter.

**Modern Indebtedness to China.**—From this most interesting drawing we certainly learn the fact, that, in ancient China, pattern-weaving looms were in use for weaving silk, having a combination of two kinds of mountings working together as one. We gather, also, that it is to China that the world is indebted for the invention of the draw-loom, and the principles of pattern weaving, principles which have been adopted to such an enormous extent in modern times, and have resulted in the development of the vast textile industries of Europe.

## CHAPTER XII

### THE SIMPLE AND COMPOUND DRAW-LOOM FOR SILK WEAVING

**Scope of the Headle Harness.**—Very small designs, as has been shown in the case of satins, can be woven by increasing the number of headles in a loom, and passing the warp threads through them in regular succession. But it is obvious that the limit of the number of headles, possible to mount and manage, is soon reached, for each headle cannot occupy much less space than an inch. Twenty headles is quite a large number, therefore, to use with convenience, and yet, a design that can be worked out on twenty threads is quite a small one, especially if the warp be of fine silk.

**Scope of the Draw-loom.**—The *draw-loom* provides a means of controlling separately the threads of a warp consisting of several hundreds, or it may be thousands, and lifting them in any order necessary for the formation of an important design. At the same time, the contrivance for doing this only occupies, in the length of the loom, space equal to that taken up by a set, or *harness*, of a few headles.

**Essential Part of the Draw-loom.**—The most essential and distinctive part of the ancient or modern loom, for pattern-weaving, is the *comber board*. This is so whether the loom be actuated by the hand and foot of the weaver, or by steam, water, electricity, or any other power. The original name was *camber board*, and the lateral repeats of a design were called *cambers*, so that the name denotes the purpose of the board, for the repeats of a design, laterally, are set out and fixed unalterably on it, as will presently be seen.

In setting out to build a loom-mounting or *monture*, the first thing to determine is the width of the stuff it is intended to weave, and the next, how many threads the warp is to consist of. These points settled, the construction of the comber board can begin.

**The Comber Board.**—Fig. 30 is a diagram of a simplified comber board. It is seen to consist of a frame

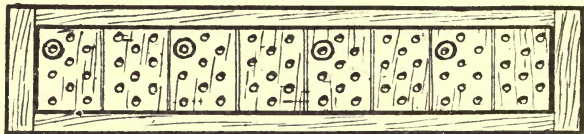

FIG. 30. COMBER BOARD

which is made a little longer than the width of stuff to be woven. This frame has its inner edges grooved in order to allow a number of thin, hard wood slips to fit into it. Eight of these are shown in the diagram. Also each of the slips is shown pierced with nine holes. The comber board is always pierced with *as many holes as there are threads in the warp*, that is, in a *simple* draw-loom. In the present case there are only seventy-two holes; but warps of silk sometimes consist of several thousand threads, in which case there would have to be an equal number of holes in the comber board.

Here, then (Fig. 30), is a comber board, having seventy-two holes in a certain fixed width. In these seventy-two holes, seventy-two looped leashes will be hung, answering to the leashes described on the headles, in Fig. 25 (p. 68), and through the eyes of these the warp will be threaded in regular order.

**Draw-loom Leashes.**—Although very similar to the headle leashes, leashes for the comber board differ

slightly from them, and must, therefore, be explained from Fig. 31. The leash consists of four parts: (1) A *long loop* of thread, which passes through the hole in the comber board; (2) an *eye* attached to it, through which a warp thread can be passed, (this eye is always made of glass when the leash is for a silk loom); (3) another loop of thread hanging from the eye, not quite so long as the first loop; and (4) a *weight* made of thin lead wire, depending from the lower loop.

Now, when the loom is in action, if a leash be pulled up through the hole in the comber board, the thread of warp, entered in the eye of the leash, will, of course, be raised with it. And as soon as the leash is released, the lead weight will draw it down again to its normal position at the warp level.

**Comber Board Leashes and Design.**—All the holes of the comber board have to be furnished with leashes, but for the sake of clearness only a few are drawn in the diagram (Fig. 32). The number of vertical lines, however, in the design on ruled paper below it, will be seen to agree with the number of holes in the same width of the comber board. The number of repeats in the width of warp is the next consideration. The design shown in the lower part of Fig. 32 occupies eighteen

spaces of ruled paper, so that there are four repeats in seventy-two spaces. Any design, therefore, that will come in on eighteen spaces, in the



FIG. 31

COMBER BOARD  
LEASH

width, of ruled paper would be workable by means of the comber board, as represented in the figure. The height of the design is immaterial.

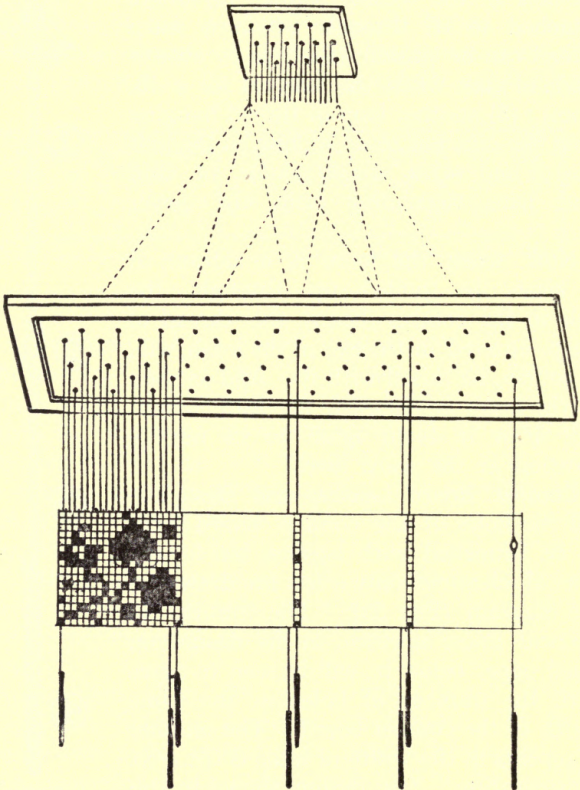

FIG. 32. DRAW-LOOM MONTURE

At the top of Fig. 32 a board is shown pierced with eighteen holes, through which eighteen cords hang. It will be seen that this is the same number as the lateral



row of squares in one repeat of the design at the bottom of the drawing.

If, to the cord hanging from the *first* hole in the *top* board, the leash answering to the *first space in every repeat of the design*, be connected, as shown by the dotted line, and the cord be drawn up, the first thread in every eighteen, right across the warp will be lifted. These threads will be seen to agree with the first space in every repeat of the draughted design, and, at that spot, in weaving, an intersection of warp and weft would take place.

Now, if all the leashes were joined up in the same manner to each successive top cord, it is manifest that any combination of eighteen threads, indicated on ruled paper, could be lifted on the four repeats, by drawing up the corresponding cords at the top of the machine.

So far, the description of the draw-loom is as applicable to the pattern looms of to-day as to those of a thousand or more years ago. In fact, no other arrangement for extensive pattern weaving has been devised.

All modern improvements have been made on the parts of the loom beyond the board shown at the top of Fig. 32, and they only accelerate the speed of working, or affect some unessential detail of procedure. They do not touch the principles of the intersection of threads, in which the whole art and mystery of weaving consists.

It is perhaps necessary to describe the automatic arrangement by which the design was worked out in the draw-loom, but it must necessarily be a very cursory description, and the reader wishing for a detailed explanation of that complicated machine must consult a work dealing exclusively with the hand-loom.<sup>1</sup>

**Pulley Cords.**—At the top of the drawing in Fig. 32 eighteen cords are seen to pass into the holes in the

<sup>1</sup> *Hand-loom Weaving: Plain and Ornamental*, by Luther Hooper. (John Hogg, London.)

bottom board of an oblong box. In the box, eighteen pulleys are arranged. Over these pulleys the eighteen cords pass, and are carried out of the side, in a horizontal direction, and fixed to a strong post or wall,

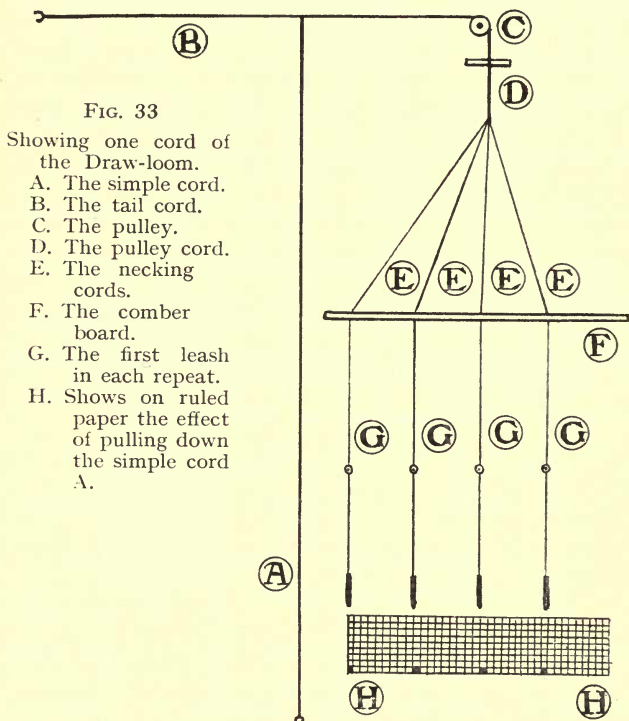

about six feet beyond the side of the loom. These cords are called the loom tail.

**The Simple.**—Midway between the side of the loom and the wall, and in a row parallel to the loom, eighteen vertical cords, called the simple, are tied at the top to

the tail cords, and at the bottom to a strong bar fixed by iron staples to the ground. Fig. 33 shows the whole arrangement as regards the working of the first cord.

Now, if the *simple* cord A (Fig. 33) be pulled down, it is clear that the pulley cord D will be drawn up, and

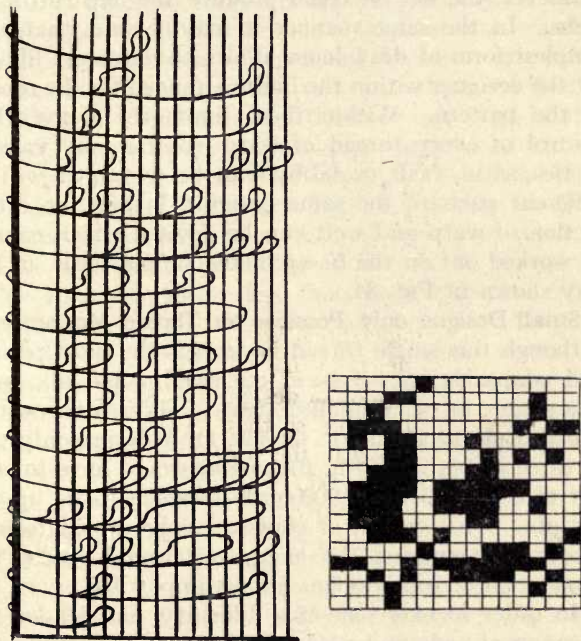

FIG. 34. DESIGN AND TIE-UP ON THE SIMPLE CORDS

draw with it the first leashes in each repeat of the comber board. This will raise the first thread in each repeat of the design, and the effect, if woven, is shown on the line of ruled paper H H.

**Tie-up of Design.**—Fig. 34 shows the way the weaver tied up the design on the cords of the simple, so that

the drawboy, who stood at the side of the loom, could readily select the right cords for pulling down, in order to form the design, line by line, as it was woven.

At page 62 it was stated that on a frame of tightly stretched threads, without any mechanical appliance whatever, the weaver could produce the most intricate webs. In the same manner it may be said, that, this simplest form of draw-loom allows the greatest liberty for the designer within the limits arranged for the repeat of the pattern. Within those limits the weaver has control of every thread of warp so that any variety of ties, satin, twill, or tabby, can be woven at will in different parts of the same design. In fact, no intersection of warp and weft can be devised which cannot be worked out on the *tie-up* of the simple cords, in the way shown in Fig. 34.

**Small Designs only Possible on Thread Mounture.**—Although this single thread *mounture* is the most perfect and adaptable one, it is, in the case of fine silk, only practicable for very small designs. Silk is often woven 400 threads to an inch; so that for a design only two or three inches in width, the *simple* would have to consist of from 800 to a 1,000 cords on which to tie up the pattern. This would, of course, involve much tedious labour in preparing the loom, and would render the production of wide designs almost impossible.

In order to overcome this difficulty, and render the weaving of wide and noble designs, in silk, possible, the double mounting was devised. This is shown, as we have seen, in the Chinese loom (A, Plate 7, p. 74).

**Diaper Weaving.**—There is an ingenious system of working two ordinary harnesses together on one warp, with a double set of treadles, called *Diaper* weaving, which is supposed by some authorities to have been used in ancient Rome. It is certain that it was known

of and practised, in Arabia and the East generally, at a very ancient date. It is a similar method of weaving to that by which chequer table-cloths are made, in linen and cotton, at the present day, and is a very admirable and clever kind of device. It is not necessary to explain it here, but it is mentioned because it probably led up to the invention of another method of small pattern weaving in silk, in which two independent *harnesses* are used. It was this double-harness weaving which no doubt suggested the combination of the draw-loom and headle harness, in one mounting for larger designs, which we see exemplified in the Chinese loom (A, Plate 7, p. 74).

**Double-Harness Weaving.**—Fig. 35 will serve to illustrate the double-harness method of weaving. At A it will be seen that the design is formed of groups in which there are never less than eight threads. Also that the black weft intersects the white warp only at the edges of the design. At B the same design is shown, but the necessary intersections for the weaving of eight-headle satin are added, in order to weave the silk into a solid, figured web. The portion at A shows the work of the figure harness, *lifting the pattern in large*; and that at B shows that of the ground or binder harness, *tying it together*.

**The Manner of Working Two Harnesses Together.**—Fig. 36 shows the manner in which the two harnesses work together. No. 1, is the section of a warp; A, is the front roller, B, is a leash of the figure harness, which is entered with eight threads of silk, C, C, are eight leashes of the ground harness, one from each of the eight headles of which it is composed. The leashes of this harness, it must be particularly noticed, have long eyes, through which the threads are entered, singly, in regular succession. No. 2 is a bird's-eye view, which will further elucidate the arrangement.

A

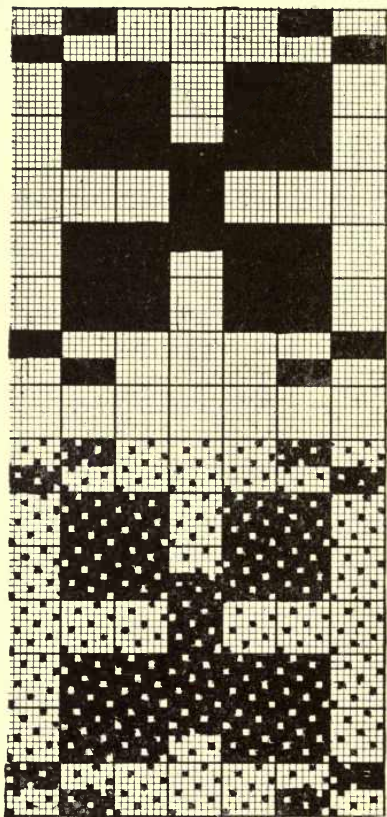

B

FIG. 35. DOUBLE-HARNES WEAVING

If one of the four headles of a harness, having leashes such as those represented at B, Fig. 36, be raised, and the front harness C C be left at rest, the effect shown at Fig. 35 A, can be woven by working that harness only.

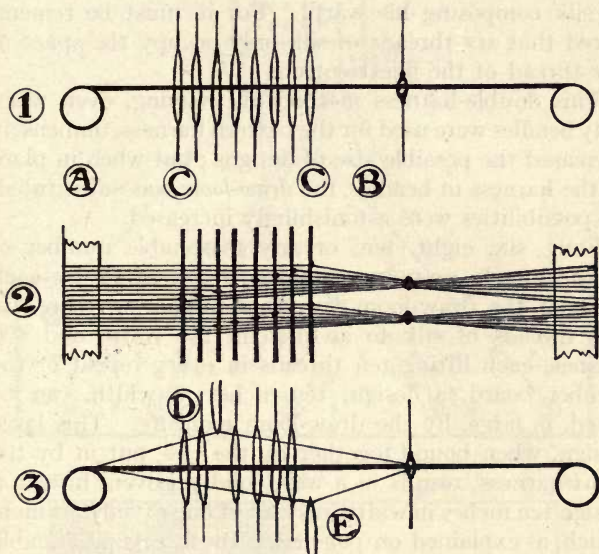

FIG. 36. DIAGRAM OF DOUBLE-HARNESS

But in order to obtain the effect shown at B (Fig. 35), the front harness must have one of its headles raised and another depressed, as shown at No. 3, Fig. 36. Headle D makes the ties on the white portion of the web and headle E makes those on the black figure, as the weft is passed through the opening, or *shed*, made by the two harnesses working together.<sup>1</sup>

<sup>1</sup> This will be more fully explained in the chapter on Satin Damask.

**Object of Double-Harness Weaving.**—There can be no doubt that this method of weaving, with two harnesses, was invented for the express purpose of enabling the weaver to weave designs of increased and reasonable size, notwithstanding the extreme fineness of the threads of silk composing his warp. For it must be remembered that *six* threads of silk only occupy the space of *one* thread of the finest cotton.

This double-harness method of weaving, even when only headles were used for the pattern harness, immensely increased the possible size of designs ; but when in place of the harness of headles, the *draw-loom* was substituted, its possibilities were astonishingly increased.

Four, six, eight, ten, or any reasonable number of warp threads may be arranged to be lifted by each leash of the draw-loom ; so that, supposing there are 400 threads of silk to an inch in the warp, and 400 leashes, each lifting ten threads in every repeat of the comber board, a design, ten inches in width, can be lifted, in large, by the draw-loom monture. This large design, when bound together by the ties, put in by the front harness, results in a web, solidly woven, having a design ten inches in width, instead of one of only an inch, which, as explained on page 86, is the largest practicable on a thread monture.

The effect, on the design, of lifting several threads together is by no means a disadvantage. The outlines of the ornamental forms are broken up into steps, and this adds point and character even to the finest, boldest designs.

The size of the design can be further enlarged by arranging the comber board for what is called a *point* repeat. Fig. 37 shows how the comber board is set out for this repeat, and the leashes connected to the pulley cords.



Difference between Point and Comber Repeats.—In this diagram a design on eighteen lines is shown (as in Fig. 32), which should be compared with it. In Fig. 32

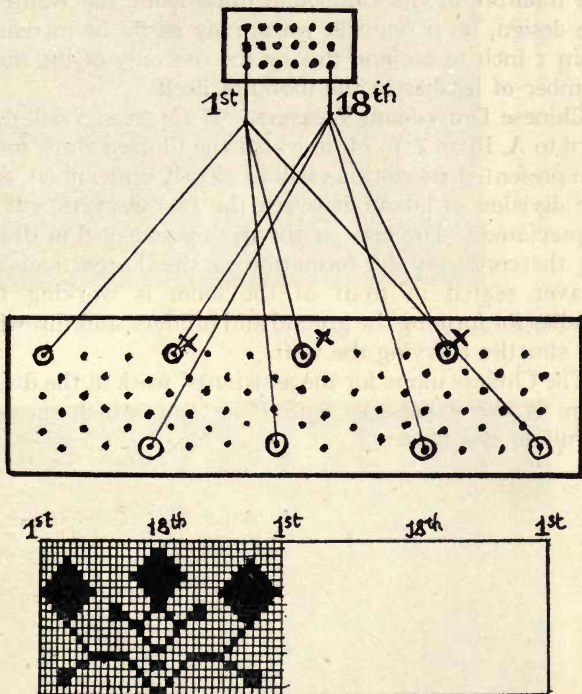

FIG. 37. POINT REPEATING MONTURE

the design repeats exactly four times in the width. But in Fig. 37, although the design actually repeats four times, it inclines twice to the right and twice to the left; so that it only, in effect, repeats twice in the whole width. A careful study of the two diagrams

will make clear how this is effected, and requires no further explanation.

By means, then, of the point repeat thus arranged on the monture of the compound draw-loom, the width of the design, on a fine silk warp, may easily be increased from 1 inch to 20, and this by the use only of the same number of leashes in the monture itself.

**Chinese Draw-loom Weavers.**—If the reader will now turn to A, Plate 7, p. 74, in which the Chinese draw-loom is represented, its working will be clearly understood, and the division of labour between the two weavers will be appreciated. The man at the back is engaged in drawing the cords for the formation of the design, and the weaver seated in front of the loom is working the headles for forming the ground and binders, and throwing the shuttles carrying the weft.

The Chinese name for the assistants' work in the draw-loom is the expressive one *Pang hua*, which means: "Pulling the flowers."



A, PLATE 8. CHINESE SILK DAMASK  
(See p. 94)  
(*Victoria and Albert Museum*)



B, PLATE 8. CHINESE BROCADE  
WITH PERSIAN INSCRIPTION  
(See p. 100)  
(*Berlin Museum*)

## CHAPTER XIII

### SATIN DAMASK WEAVING

**The most Perfect Textile.**—Although not so gay and brilliant as the multi-coloured brocades, tissues, and embroideries for which the Chinese have always been famous,<sup>1</sup> the kind of silk weaving now called *satin damask* is the most perfect in texture, and ingenious in construction of all textile fabrics.

This form of weaving is also a Chinese invention. In some of the most gorgeous brocaded and embroidered webs of ancient China, figured satin is used as a groundwork with splendid effect. A, Plate 8, is photographed from a Chinese yellow satin damask in the Victoria and Albert Museum.

**Description of Satin Damask Technique.**—Satin damask is a two harness system of weaving, and for webs of large design requires the use of a compound draw-loom.

The definition of the design in damask weaving depends on the difference between the front and back surfaces of satin webs. Plain or tabby weaving has no right or wrong side, the two surfaces being exactly alike. This is not the case with twills or satins.

As pointed out at page 69, 70, etc., the front of a plain satin is nearly all warp and the back nearly all weft. This, even when warp and weft are of the same colour, makes a marked difference between the surfaces. As the long warp loops, on the front, are longitudinal

<sup>1</sup> As it is impossible to describe these at length, the reader is referred to *Chinese Art* and *Handloom Weaving* previously mentioned.

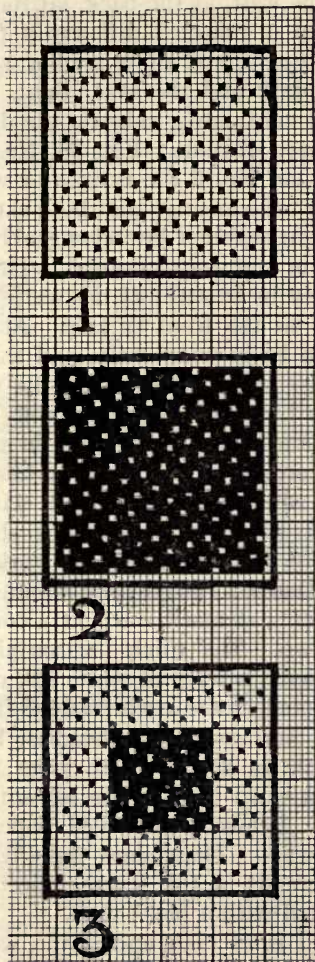

FIG. 38. DRAUGHT OF SATINS

and those of the weft, at the back, latitudinal, the light falling on them is reflected differently from each. If both were photographed in a similar side light, one would appear dark and the other light. But, if warp and weft be of contrasting colours, the difference is, of course, still more obvious. Fig. 38, No. 1, represents a warp satin, and No. 2 the reverse or weft satin.

It is possible to so arrange that both satin and reverse satin are brought together interchangeably on both surfaces of a web in any shapes desired. Thus, the ground of a design may be in satin of the warp and the figure in weft satin, on the front surface. At the back the figure will then be in warp satin, and the ground, weft satin. In other words, if the warp be white and the weft black, on the front the figure will be black on a white ground, and at the back, white on a black ground. Of course, according to the more or less frequency of the ties, the white will be tinged with black, and the black, with white. This effect is shown at No. 3. Fig. 38 and Fig. 39 will explain its working.

**Working of Damask Harness and Monture.**—In Fig. 39 four sections of a damask warp in a compound drawloom are shown. The thick horizontal line, in each number, represents a warp of white silk of any number of threads entered, *five* in each leash of the monture A. Below B is a harness of five headles, having leashes with long eyes, as described at page 89. Through these eyes the warp threads are all entered *singly* in regular order. Below C are ruled paper drawings of fifteen spaces wide. These show the effect of the position of the threads in the several numbers, the warp being intersected with a black weft.

At No. 1 all is at rest, and if the weft be thrown across it will simply lie on the top of the warp. This is shown by the black squares all being filled in. At No. 2,

one leash of the figure monture has been raised, and the effect is shown on the ruled paper. The weft has passed under the five threads raised by the leash and over the threads left at rest. At No. 3 the fourth headle has been raised, as well as the leash of the figure monture. This has, of course, no effect on the five threads already

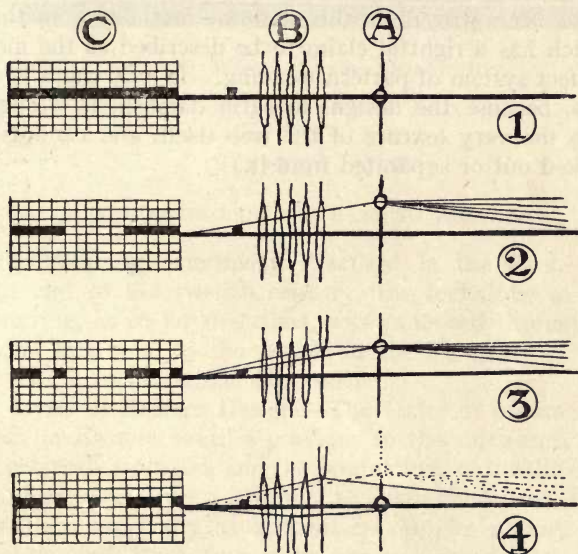

FIG. 39. DIAGRAM OF DOUBLE HARNESS

up, but has made a tie on the two spaces of weft, on each side of the figure. At No. 4, not only are the fourth headle and the leash of the monture held up, but the third headle of the harness is held down. The latter has no effect on the warp threads which are down, but the third thread, in every group of five raised, is prevented from rising, and the weft passing over it,

has made a tie on the satin figure. It follows that, whether few or many of the figure leashes are raised in successive lines of the design, the ground and figure will be tied at regular intervals, on both back and front of the web, by the working of the front harness.

An inspection of any fine collection of textiles will show that some of the noblest European silken webs have been woven in this damask method, a method which has a rightful claim to be described as the most perfect system of pattern weaving. It may claim to be this, because the design, in satin damask, is wrought into the very texture of the web itself, and cannot be picked out or separated from it.





FIG. 40. WOVEN ARABIC INSCRIPTION

## CHAPTER XIV

### SILK WEAVING IN THE EAST TO A.D. 1200

**Silk Weaving extensively Practised in the East.**—By the end of the twelfth century, the technique of silk weaving, as so far described, was practised throughout Asia, and was, to the people of the East, one of the chief modes of artistic expression.

**Styles of Eastern Design.**—The styles of ornamentation in Eastern textiles previous to the thirteenth and fourteenth centuries, and the productions of the different countries, are very difficult to distinguish one from another, especially as authentic examples of any but Coptic and Byzantine webs are so exceedingly rare. Broadly speaking, however, *Chinese* designs are characterized by a natural treatment of flowers and other objects, and easily recognized and oft-repeated symbolic forms.<sup>1</sup> The Chinese work is, as a rule, extremely fine and delicate, as well as being gay and brilliant, but not gaudy, in colour.<sup>1</sup>

Ancient *Corean* and *Japanese* designs are rather more

<sup>1</sup> For lists of these, see Dr. Bushell's *Chinese Art*.

conventional in treatment than the Chinese, but with a fine, not a childish or ignorant, conventionalism.

B, Plate 8, is a beautiful specimen of *Chinese* or *Persian* silk weaving on the draw-loom. It is most probably a Chinese rendering of a Saracenic design, the arrangement being Saracenic and the details Chinese. The inscription, in Arabic characters, signifies "Glory to our Lord the King, the just and learned Näsir Eldin." It is possible that the web, of which it is a fragment, was woven in China as a present for the Sultan Näsir Eldin, who reigned in Persia 1233 to 1341 A.D. This Plate is photographed from Lessing's superb book of reproductions of the textile treasures of the Berlin Museum.

**Saracenic Weaving and Design.**—This beautiful specimen of *Chino-Saracenic* silk weaving, with its inscription, naturally suggests a notice of the great part played by *inscriptions* in the ornamental silk textile of *Saracenic* or *Arabian* production.<sup>1</sup> "Glory to our Lord the Sultan," "Glory, victory, and long life" (see Fig. 40), "There is no God but God," "There is no Conqueror but God," and such like short sentences and ejaculations, arranged in separate compartments or interlaced with tracteries of intricate design, from which we get our word *Arabesques*, are most frequent. In one extensive branch of Saracenic design, representations of animal or vegetable life were excluded; but in another, particularly in Persia, they were freely used.

**The Woven Art of India.**—In the woven art of India the greatest use was made of the human figure, of beasts and birds of various kinds, and more or less vigorous and naturalistic pictures of the chase. These Indian

<sup>1</sup> There are many interesting specimens of these to be seen in the Textile Department of the Victoria and Albert Museum, some dating from very early times.

hunting scene fabrics appear to have been very popular in ancient Greece. Homer, describing the ornament on a king's robe, says :—

“ In the rich woof a hound mosaic drawn  
 Bore on full stretch and seized a dappled fawn ;  
 Deep in his neck his fangs indent their hold :  
 They pant and struggle in the moving gold.”

HOMER. *Odyssey*, Book 19.

Coptic and Byzantine design in textiles partook of the nature of most of the above, and mixed with them classic ornament and the symbols and scenes of Christianity, as well as the striking incidents of Biblical history, in a simple and childlike manner (Fig. 41).

**Perfection of Oriental Weaving.**—Although so few specimens of ancient Oriental silk weaving remain to us, there are sufficient to prove that, by the end of the tenth century A.D. from Constantinople to the Far East, and from China to Southern India, the manipulation of silk in textile art, and the mechanism of the loom, had reached to a pitch of perfection which has seldom, if ever, been surpassed, either for quality of craftsmanship, beauty of texture, or ingenuity of design.



FIG. 41. COPTIC ORNAMENT



FIG. 42. SICILIAN WOVEN ORNAMENT

## CHAPTER XV

### THE INTRODUCTION OF SILK WEAVING INTO EUROPE

**Silk Weaving in Italy.**—Silk weaving and sericulture, which, we have seen, were so long practised throughout Asia with so much success, are said to have been introduced into *Sicily* and *Venice* and various parts of Italy in the twelfth century by Saracenic craftsmen. These skilful artificers had been captured in war and brought as slaves to Italy, or induced by fair promises of patronage to settle there, and, setting up their looms and arranging their other appliances, they there carried on their beautiful and ingenious arts.

Traditional stories are related, by many authors, of the circumstances under which this introduction of the finer textile arts into Italy took place. These stories may be true or not, but they add, at any rate, the glamour of romance to this interesting and important event, or rather events; for there can be no doubt that between the tenth and fourteenth centuries, which were times of great adventure and activity in all departments of life, many of these compulsory or voluntary settlements of silk weavers and other handicraftsmen took place.

**Trade in Silken Webs.**—The productions of the



A. PLATE 9. SPANISH MORESQUE, 15TH  
CENTURY. (See p. 104)  
(*Victoria and Albert Museum*)

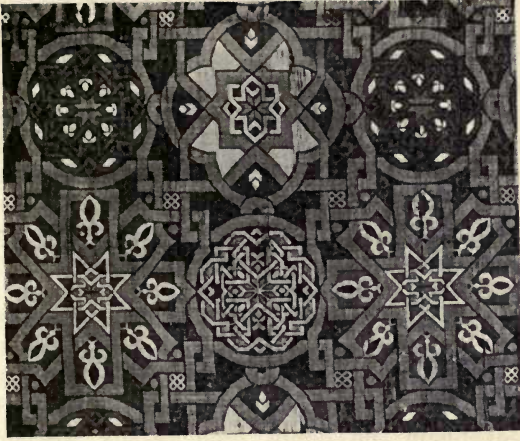

B, PLATE 9. SPANISH MORESQUE, 15TH  
CENTURY. (See p. 104)  
(*Victoria and Albert Museum*)

fascinating textile art, thus introduced, soon became notable *commodities of commerce* in the districts where the Oriental silk weavers established themselves and commenced their work. *Palermo* and *Venice* soon became famous throughout Europe as the centres of an extensive trade in the costly webs of silk and gold thread made in the various districts of the country where the new weaving industry took root and flourished.

**Introduction to Spain.**—Although there seems to be no definite record of the fact, it is probable that silk weaving was done in *Spain* at an earlier date than in *Italy*. The conquering Moors, whose Oriental characteristics made such an indelible impression on the arts and life of Spain, no doubt brought silk weaving together with metal working and other Arabian handicrafts, with them when, in the ninth century, they conquered and overran that country. The early Moresque webs, however, seem to have been little esteemed in Europe, for it was from Italy that the silken fabrics were distributed, and the art of silk weaving itself spread into France, Germany, and finally to England. The reason of this is not far to seek. In Spain, the Moresque art of the conquerors naturally remained purely Arabian and, therefore, alien in style, even so late as the fourteenth and fifteenth centuries. But in Italy, where the craftsmen did not belong to the dominant classes, the Eastern elements of design were early blended with the existing art of the country, and formed a composite style of ornament which was fresh and new, but not too unfamiliar to become popular. Plate 9 gives two examples of Spanish webs of the fourteenth and fifteenth centuries. They are seen to be purely Arabian in design, although the Moors had certainly been in Spain more than six centuries when they were woven.

**Introduction of Silk into England.**—It is probable that there was yet another early introduction of silk workers to Europe from the East, this time into England; for early in the fourteenth century there is recorded an Act of Parliament which was passed to protect “certain old-established silk women against Lombards and other Italians who brought such quantities of silk threads and ribands into the country that the established native throwsters were impoverished.” By this Act the importation of such articles was forbidden. This is the first definite reference to silk weaving on record in England. A little after this time English embroidery in silk became famous throughout Europe, and was much in demand. These early throwsters and weavers were, therefore, no doubt, employed in making and twisting up raw silk, obtained at great cost from the East, into threads for the embroiderers, and in weaving the webs of diaper silk and cloth of gold on which the embroideries were usually worked.

**Early English Embroidery.**—The Syon Cope,<sup>1</sup> which is generally considered the finest specimen of Early English needlework, is said to have been worked in the thirteenth century by nuns in a convent near Coventry. In the fifteenth century it belonged to a convent at Isleworth, in connection with the monastery of Syon, and at the dissolution of the monastery was carried by the nuns to Lisbon, where they took refuge. Here their convent was twice destroyed by earthquakes, and after several migrations, they returned to this country. In Staffordshire the Earl of Shrewsbury provided them with a home; and in gratitude they presented him with this their most precious relic. The

<sup>1</sup> Victoria and Albert Museum, South Kensington. A small reproduction of this fine work would be of little value. The actual embroidery should be seen and studied in the Museum.

Earl of Shrewsbury bequeathed it to the nation, and now it is one of the chief treasures in the fine collection at Kensington. Its expressive sacred scenes, its traceries and emblems, its heraldic devices correctly blazoned, its subdued but exquisite colours, and the richness of its material, combined with its perfect stitchery render it the most extraordinary and beautiful existing specimen of the art of the embroiderer.

There is another piece of undoubted English embroidery of the fourteenth century preserved in the South Kensington Museum. It is particularly interesting, because of the ground of plain silk velvet, with a cut pile, on which it is worked. Specimens of such silk velvet, whether plain or figured, are extremely rare of earlier date than the fifteenth century. But at the end of the fifteenth century, or the beginning of the sixteenth, silk velvet weaving reached its highest perfection both in Asia and Europe.<sup>1</sup>

Whether the inventor of the process of velvet weaving was Italian, Spanish, Saracenic, or Chinese, cannot be determined, but the invention itself was quite an original one, as hitherto all attempts to weave a web, having a pile surface, had been made by knotting in the weft, on a stretched warp, in the same manner as the pile of Persian carpets is still made. The most wonderful specimen of this ancient kind of pile weaving is the Persian cope, also in the Kensington collection. This knotted pile has about 1,000 knots of silk, separately tied and cut, to every square inch.

<sup>1</sup> For a description of the process of velvet weaving, see *Hand-loom Weaving*, by the Author.



## CHAPTER XVI

### DEVELOPMENT OF EUROPEAN SILK WEAVING

**Italy the Source of European Silk Weaving.**—Although, as we have seen, it was not only through Italy that silk was introduced to the Western world from the East, it was from that country that the knowledge was obtained from which the vast European industries dealing with silken thread have been developed.

**Restricted Meaning of Word Damask.**—At first, all kinds of silken webs were known as *damasks*, probably because Damascus had been a famous mart for their export before they were made in Italy. The word *damask*, however, afterwards became restricted in its meaning to the kind of weaving described in Chap. XIII. Other kinds became known as *brocades*, *brocatels*, *tissues*, and by many other names.<sup>1</sup>

During the three centuries in which the Italians were able to keep to themselves the secrets of sericulture, and the monopoly of silk weaving, the style of design, of course, changed, and great advances were made in the technique of the webs produced. Anything like an adequate description of these would fill many volumes such as the present one, and cannot be attempted here.

**Excellence of Italian Silk Weaving.**—In Italy, during the period from its introduction till the sixteenth century, the various kinds of silk weaving mentioned above were brought to a point which for excellence has never been surpassed, whether we consider their design, which

<sup>1</sup> See *Hand-loom Weaving*, Luther Hooper.

was of the noblest ; their colour, which was the most glowing and permanent ; or their technique, which appears to have been mechanically perfect.



FIG. 43. SICILIAN DAMASK. THE HART AND SUNDOG DESIGN

**Isolation of Italy in the Middle Ages.**—A striking evidence of the isolation of the different countries of Europe, during the Middle Ages, is furnished by the fact that Italy was able to keep to herself the profitable mystery of silk manufacture and pattern-weaving for more than four centuries after its introduction from the East, although the productions of the Italian looms were

so highly prized and so much sought after by the rest of Europe.

**First Silk Weaving in France.**—The first record we have of silk weaving being done in France, is to the effect that a few Italian weavers escaped into that country in 1480, and, setting up their looms, started silk weaving. They were much encouraged by the French authorities. Other immigrations followed, from time to time, to various towns in the south of France. The Italian weavers settled chiefly in Lyons, which soon became a centre and mart for the industry. Although thus encouraged, and occasionally favoured by the notice of royalty, it was not until the end of the sixteenth century that silk weaving really became a French industry, as up to that time it was carried on exclusively by Italians, who took with them Italian ideas of design and method, and who, moreover, could only cultivate the silkworm to a very small extent. Owing to this, it is almost impossible to distinguish early French silk weaving from that of Italy. Although there is no record of the fact, it is probable that the same thing occurred in regard to Germany and Flanders, as there is still more difficulty in distinguishing early German and Flemish, from Italian webs.

The art of silk weaving and the practice of sericulture flourished exceedingly in France until the end of the seventeenth century, when the great dispersal of silk weavers, to Protestant countries, took place.

**Dispersal of Huguenot French Silk Weavers.**—Many thousands of these persecuted people took refuge in England. The immigrants introduced their handicraft and its dependent trades, and, settling down, soon became of inestimable benefit to their adopted country.

The French weavers were not allowed to settle in England and practice their handicraft without much

opposition from the English silk weavers already at work. These, in fact, petitioned Parliament to forbid them, alleging that the strangers had no right to work, as they had not been apprenticed here ; their objections were, however, overruled, and the Huguenots were encouraged by the authorities to settle in certain districts, notably at Canterbury and Spitalfields. The reinforced silk industry quickly grew, and prospered exceedingly for rather more than a century. There can be no doubt that the industrial supremacy of England in the nineteenth century was indirectly due to these refugees.

The webs woven by the French weavers in England were, as was natural, so similar in character to the French, that it is impossible to distinguish them as English, just as we have seen the early French weaving was undistinguishable from Italian.

During the eighteenth century in France the silk industry soon recovered from the check it had received owing to the revocation of the edict of Nantes, and the French designers and weavers again obtained a supremacy in the art which they have ever since been able to maintain.

## CHAPTER XVII

### ENGLISH SILK WEAVING TO ABOUT 1800

WE have already seen that in the thirteenth, fourteenth, and fifteenth centuries, England was famous for its embroidery in silk and gold ; also that there was an incorporated society of silk workers, and weavers of diaper grounds.

**Richard II's Embroidered Coat.**—There is one other record in the fifteenth century which informs us that cloth of gold and silver were being made in London, and that Richard II had a coat of cloth of gold enriched with embroidery of silk and precious stones, the value of which was 31,000 marks.

**Refugees from Holland.**—In the sixteenth century, religious persecution broke out in the Netherlands, the free cities of which were at that time famous for their success in the practice of the textile arts. The oppression of the Protestants by the Duke of Alva, acting under orders from Spain, became so grievous, that many of the best craftsmen left their native towns, and came to England, craving permission to settle down and work at their trades of silk weaving and other crafts.

Thousands of these skilful Hollanders took up their abode in various parts of the East Coast, but particularly at Colchester and Norwich. The latter city owed to them the subsequent development and success of its great weaving industry.

**First Draw-loom in England.**—The first draw-loom for weaving silk, damasks and velvets, in England were set up by these refugees in Norwich in 1567.

**John Tice.**—In 1573 John Tice attained to the perfection of making all sorts of “tufted taffetas, cloth of gold tissues, wrought velvet, branched satins, and other kinds of curious silk stuffs.” A diarist also records that “Queen Elizabeth refused to wear any but silk stockings.”

**Formation of Livery Companies of Silkmen.**—In 1629 the Livery Company of Silk Throwsters of London was formed, and in 1631 the Company of Silkmen was also incorporated.

**Spun Silk.**—In 1671 a patent was obtained by one Edmund Blood, for carding and spinning silk waste in a similar manner to that of cotton spinning.

These notices, brief as they are, all point to the fact that a great deal of silk was used at that time in this country, although the chief textile industries were concerned with wool and linen.

**Value of Imported Silk, 1686.**—In this year the value of raw silk imported was reckoned at £700,000.

**Huguenot Immigration.**—Between 1695 and 1700, the Huguenots sought a home and livelihood in England, and gave an effective impetus to the textile and other industries of the country, especially to silk weaving.

**Eighteenth Century Silk Weaving.**—The story of silk weaving during the eighteenth century in England is full of interest. It was at its most prosperous point in the second half of the century, when it even threatened the supremacy of Lyons in the trade. From that time, however, it began to decline. There were many causes for this, not the least being the many and fierce disputes which took place between masters and men, as more capital began to be invested in the trade; and the fascination which parliamentary and legal processes seem to have had for both parties. The unrest and shifting of the centres of trade, which accompanied the rise of the great machine industries, also affected it.

But, most of all, the absence of healthy competition in quality of craftsmanship, resulting from the strict prohibition of manufactured silk from other countries, must be considered responsible for this lamentable decline.

We have only to compare the later Spitalfields, and other English silks, with the dainty productions of China, India, and France in the eighteenth century to be confirmed in this opinion. The silk was in them—the best silk, and more than enough of it, but the dyeing, the manipulation, and the design, were all very inferior. The Huguenot traditions of French art had gradually been dissipated, and no new inspiration had arrived.

## CHAPTER XVIII

### MODERN SILK WEAVING

MODERN silk weaving may be said to have begun with the application of steam-power to the loom, and the introduction into general use of the machine invented, or perfected, by Jacquard at the close of the eighteenth century. By means of this machine the weaver's "tie-up" of the pattern in the loom, the complicated system of pulleys, cords, and loops necessary for raising the warp threads for the formation of the design, and the weaver's assistant (the drawboy) were all superseded.

**Difficulties of Power-loom Invention.**—Many attempts had been made, with more or less success, to devise machines that would, when actuated by unskilled labour, or water, steam, or any other power, weave plain cloth automatically. These attempts always failed at one point: the *throwing* and *catching* of the shuttle. And even now, after more than a hundred years of experiment, it is just at this point that the hand-loom is superior to the power-driven machine. In order to confirm this statement, it is only necessary to watch and compare the machine and the man in this particular.

The machine drives the heavy shuttle with a force, noise, and clatter that seems out of all proportion to the delicate thread of weft, which is carried across the still more delicate threads of warp, at lightning speed. The man or woman, as the case may be, silently and gently throws and catches the light, beautifully curved hand shuttle, which is so perfectly adapted for its purpose, with astonishing speed, delicacy, and evenness.



**John Kay's Fly-shuttle.**—Until about the middle of the eighteenth century all shuttling had been done by hand, but, in 1733, John Kay invented the *fly-shuttle* for the hand-loom.<sup>1</sup> His idea was that wide webs, which had hitherto required two weavers to make—one to throw and the other to catch the shuttle—might be woven by one weaver alone; and, moreover, that narrow webs might be woven with increased speed. This contrivance was seized upon by the inventors of power-driven looms, and their difficulty was to a certain extent overcome. For it is the principle of Kay's invention, with slight modifications, that has been used in power weaving ever since. It is said that Kay spent all the money he made by his invention in defending his patent rights, without success.

**Chief Difficulty of Power-loom Invention Removed by Fly-shuttle.**—John Kay's simple invention cleared the way for the practical completion of the power-loom, which, however, still took about fifty years to bring into general use. In 1800 there were about 20,000 power-looms at work in Great Britain, weaving plain stuffs of all kinds of material, and about 250,000 hand-looms.

**Proportion of Power to Hand-looms.**—At the present time, in this country, although the hand-loom is not extinct, as some people suppose, the demand for best goods, which cannot be made, with profit, by power, is so small that the number of hand-looms at work may be easily counted by hundreds.

**The Jacquard Machine.**—While the power-loom was thus being brought into use in England, Jacquard, in France, was completing and making practical his invention for automatic pattern weaving. When the machine was successfully finished, Jacquard's first reward was

<sup>1</sup> For description of hand and fly-shuttles and appliances see *Hand-loom Weaving*, Luther Hooper.

a public prosecution, and the ignominious burning of his machines and models in the market-place of Lyons. On the spot (by the way) on which this was done Jacquard's statue in bronze is now erected.

In about twenty years after its completion, Jacquard's machine began to be appreciated, and in 1820 some were smuggled into England and secretly set up. In spite of much opposition, they soon came into general use, first and particularly for hand-loom and silk weaving, but afterwards for power-loom, and the weaving of all kinds of fancy and ornamental webs.

**Cards for the Jacquard Machine.**—The Jacquard machine, in the modern loom, whether the latter be actuated by the hand and foot of the weaver or by steam power, takes the place of the pulley-box of the draw-loom and all the system of cords beyond it (see Chap. 12). Also the endless band of cards, on which the pattern is punched out, and by means of which the design is formed and governed, line by line, in the machine, takes the place of the weaver's tie-up on the simple cords.<sup>1</sup>

**Ruled Paper Draughting.**—With regard to the working out of the design on ruled paper, or *draughting*, as it is called, this has to be prepared in exactly the same way for both the draw-loom, and the Jacquard machine. The draughts prepared for any of the seventeenth or eighteenth century draw-loom webs, some of which may be seen in the print room of the South Kensington Museum, could be quite readily, and without alteration, read on to cards, and woven into a web, on any most modern pattern-loom. It is necessary particularly to emphasise this point, because it is so generally lost sight of. Most people who have anything to do with

<sup>1</sup> For a description of the Jacquard machine and its method of working, see Pariset's *Les Industries de la Soie*, p. 271, etc.

weaving, to say nothing of the general public, suppose that *Jacquard weaving*, as it is called, is a new system altogether, instead of being, as it is, only an ingenious substitute for an unessential adjunct of the draw-loom.

**Facilities given by the Jacquard Machine.**—The principal advantage, if it may be considered one, of the use of the Jacquard machine is the facility it gives for a frequent and easy change of pattern. It is only necessary to take down one set of cards, and put up another, in order to change the design in a loom. The result of this facility was, that, the early nineteenth century witnessed a perfect orgie of fantastic ornamentation. When once a set of cards is punched, the most elaborate design is as easy to produce as the simplest, and accordingly the manufacturers of that time vied with each other as to the number and originality of the patterns they could produce. The profession of designer became a most lucrative one, and, in fact, as a profession is itself an outcome of the invention of Jacquard. Previous to this time the master weavers, or someone in touch with the looms, had arranged the designs on them, and these, when once arranged, were good for a lifetime. But with the new draw engine, a craving for constant change had the result described, especially in England.

**Wonderful Scope of Jacquard Machine.**—For good or ill, however, the Jacquard machine came to stay, and since its general adoption, all silk pattern weaving, by hand or power, has been done by its means. As a work of mechanism it is truly wonderful, for it can be made to govern all the operations of the loom, except throwing the shuttle and actuating the lever by which it itself works. It governs the pattern and ground, regulates the length of the design, changes the colours for the shuttles in proper succession, rings a bell when

certain points in a web requiring different treatment are reached, regulates the take-up of the woven cloth on the front roller, and many other details, all by means of a few holes punched in a set of cards. Its great defects are the dreadful noise it makes, and the ease with which it gets out of order. These render it only suitable for factory use, where noise does not seem to matter, or at any rate has to be endured, and where a machinist is constantly at hand to keep it in order.

**Advantage of Power Weaving.**—The advantage claimed for the power-loom is, of course, the speed at which its webs are produced. This speed is, however, not so great as at first appears. The careful and exact preparation of the machine-loom for any new kind of work, and the looking over, cleaning, and otherwise preparing the warps before they are fit to work in the machine, all has to be done by hand. This preparation, if added to the actual time occupied in weaving, would considerably lessen the yardage produced in a given time. Of course, the labour is not so skilled, and is, therefore, cheaper. If great quantities of one kind of material are required, it must certainly be granted that weaving them by power is cheaper. But when that is said, all that can be said in favour of weaving by power, as it is done at present, is said.

**Disadvantage of Weaving by Power.**—The disadvantage of weaving by power is, that only webs which can be run for miles and are sure to sell largely, for stock, are worth weaving at all. This means that anything special, of which only moderate quantities are required, cannot be obtained. Now, as most good things are special, either in design, colour, or manipulation, with only the power-loom at work, their weaving could not be done at all at a profit. It is just here that the useful hand-loom comes in.

**Machinery to be Improved, not Abandoned.**—The bad effect of the monotonous labour on the *hand* tending a power-loom, in common with other kinds of machinery, has often, of late, been commented on. This is not to be obviated by abandoning the use of machines, but rather by making them more perfect and amenable. This will be the result of a more general use of the electric agency, which is bound sooner or later to bring about a revolution in the principles and construction of machines for silk weaving, amongst other things. When this happens, the ruthless, noisy monsters of steel and wood, which were the pride of the nineteenth and early twentieth centuries, will be things to wonder at, in the museums of the future.

**Adulteration of Silk.**—The fibre of silk, unfortunately, lends itself particularly to scientific adulteration, which is the most shameful vice of manufacture to-day. Not only does silk take kindly to adulteration, but, in the general estimation, looks all the silkier the more it is adulterated. Most people like silk to look very bright and shiny, forgetting that pure silk shines with a subdued pearly lustre, whether only boiled off and freed from the gum, or dyed with pure colour. At page 3 it was stated that silk has a great affinity for water, and can absorb about one-third its own weight without feeling wet to the touch. The dyer early found that it would absorb other things beside water, *muriate of tin* amongst them. As a matter of fact, it may be, and indeed is, made by the dyer to take up, with the dye, so much of that metal, that *twelve ounces* of boiled silk can be increased in weight to *eighty ounces*, and yet look like very bright silk. This scientific dyeing has been practised to such an extent, that it is well-nigh impossible to purchase in the market pure silk goods that will stand the test of wear and time. They are, in fact, only made to sell.

The writer knew of a piece of modern silk, made in Spitalfields, but with weft dyed in Germany, which being put away in a drawer, and left there in the dark for a few months, was then taken out, at least what was left of it; the weft had gone to fine powder, and was mixed with the other things in the drawer. With more or less of this scientific adulteration, is it surprising that modern silks crack and are out of favour?

## CHAPTER XIX

### SPUN SILK

The Utilization of Waste Silk of various kinds has already been referred to on pages 15 and 47, but of late years there has been such a considerable increase in the production of and demand for spun silken yarn that in this the third edition of "Silk" it is deemed necessary to devote a special chapter to a description of the source, preparation, character and utility of this particular production of the modern manufacturer. In the first place, it is necessary to define the term waste silk. The waste silk utilized is not, except for most inferior yarn, made by tearing up and reducing to ultimate fibre woven silken stuffs that have served their turn, been worn out and their tattered remnants torn to shreds, by means of a machine known as the "devil," as is the case in the manufacture of shoddy yarn in the woollen trade. The waste silk fibre, from which good spun silk is made, is pure new silk which for some reason or other cannot be thrown and successfully manufactured into *net* or *neat* silk thread as the unspoiled reeled, continuous fibre, as made by the silkworm, can be.

**The Waste Fibre.**—It is certain that a comparatively small proportion of the fibre made by the various kinds of silk producing moths, throughout the world, can be reeled off in such a condition as to undergo successfully the severe processes which the manufacture of thrown silk demands. Even with the cocoons of the most perfectly bred and tenderly cared for silkworms there is a considerable proportion of unavoidable waste. This waste has, of course, always been available

and it was only to be expected that the clever, economical people, the Chinese, who were, as we have seen, the first craftsmen to find means of utilizing the silkworm fibre and to domesticate the most prolific of the silk producing species of worms, should be the first to make use of the silk of the spoiled cocoons, spoiled from whatever cause, to make use of the matted, and tangled filaments which are found at the outside and inside of every cocoon, and of the waste which necessarily occurred during the severe course of manufacture which the silkworm fibre has to undergo before it becomes usable thread. Even with the most modern scientific treatment the waste from these principal causes still exceeds the weight of neat silk produced from any given quantity of cocoons.

**The Chief Source from which the Raw Material is Obtained.**—It is not only from the waste silk fibre of the cultivated or domestic silkworm that the raw material of spun silk is obtained in the present time of machine spinning.

The waste silk from the nests and forsaken cocoons of the *Anaphe* silk producing moth of Africa, already referred to on page 15, to say nothing of the wild silkworms of China, Japan, India and many other Oriental and Western European countries, are gradually coming into use for making spun silk thread. Better methods of preparing this waste product are being discovered, and special machinery for spinning it has been invented. These sources of supply seem to be inexhaustible and, particularly in the case of that from Africa, have at present scarcely been tapped.

**The Preparation of the Raw Material.**—In the case of spun silk the *sericin* or natural gum is discharged from the fibre before it is spun or even carded ; consequently, spun silk is a much softer and more lustrous



thread than thrown reeled silk until the latter has been "boiled off" as it is called by the dyer. The discharge of the gum from waste fibre in the present day differs only in minor details from a description of the process given by one Ephraim Chambers in his *Cyclopaedia of the Arts and Sciences* (1728). It is as follows— "As to the balls (cocoons), after opening them and taking out the insects they are steeped three or four days in troughs the water whereof is changed every day to prevent their *stinking*. When they are well softened by this scouring and cleared of that gummy matter the worms had lined the inside with, they boil them half-an-hour in a ley of ashes very clear and well strained; after washing them out in the river and drying them in the sun they card and spin them on the wheel."

**Spinning**, as the artificial making of continuous thread from the more or less short filaments of the fibre of cotton, flax or wool is called, consists simply of more or less tightly twisting the drawn-out rove of filaments together. The fibres of the above mentioned substances and a few others, from some peculiarity of their construction, have a natural tendency to cling together when thus twisted. The reader can confirm this fact by a simple experiment. If a few fibres of sheep's wool or cotton wadding be drawn out into a thin rove a few inches long they will, of course, barely hold together; but if the rove be carefully and tightly twisted, a fine permanent thread will be made which will bear a considerable strain. This is the simple principle on which all continuous threads are made, whether on the prehistoric spindle with or without a distaff, on the ancient or modern spinning wheel, or on the most modern machine capable of spinning two or three hundred threads at a time.

The first spinning machines were invented to spin cotton fibre the filaments of which are only from an

inch to an inch and a half in length. It was found impossible on these machines to spin waste silk, no matter how carefully it had been carded, because of the excessive and varied length of its filaments. This difficulty was overcome by cutting the fibre into short lengths; but this treatment rendered the finished thread weaker and duller than that produced from long filaments on hand wheels.

It was not until machines were invented capable of carding and spinning long fibred waste that spun silk became popular and in great demand for embroidery and weaving and knitting the many beautiful modern textile fabrics for which it is used.

**The Character and Utility of the Yarn.**—The spun silk yarn produced in this country of late years is distinguished for its strength, lustre and purity. It is chiefly used for weaving of all kinds, plain cloths, velvets and plushes, handkerchiefs, ribbons, upholstery goods and trimmings. All kinds of hosiery goods are knitted of spun silk either by itself or mixed with wool or cotton. It is also used for lace making, for embroidery, and for machine and hand-sewing thread.

## APPENDIX

### FIRE HAZARDS INCIDENTAL TO SILK MILLS AND FACTORIES

BY T. D. RAINE, F.C.I.I.

OF the various fibres used for the manufacture of threads and fabrics, either by hand or machinery, silk occupies a unique position inasmuch as it is neither a vegetable fibre nor an animal hair. Nevertheless, it really belongs to the animal kingdom, and in the minds of fire insurance officials it has one important characteristic which allies it to the animal hair family, in that it is non-inflammable. Vegetable fibre (such as cotton, flax, hemp, and jute) burns readily, especially in a raw state, and the fire risk is considerable unless the factories in which it is worked are either fireproof or equipped with modern fire-fighting appliances. On the other hand, those factories which solely use animal hair, such as wool, alpaca, camel's-hair, goat-hair, etc., do not present anything like the same hazard, and it is with the latter that silk mills are classed as regards the degree of fire risk, in fact, the silk mill is often found to be actually on a slightly lower basis of fire insurance rating than a wool mill. This is probably because of the fact that there are not enough silk factories in the country to warrant the drawing up of a schedule of standardized rates based on actual fire loss experience, or it may be that the better class silk factories are cleaner than wool mills because they are manipulating a more expensive material, but against this, however, it must be noted that serious fires in waste silk spinning mills have been fairly numerous, especially in Yorkshire.

Silk factories are divided into three main classes from a fire insurance point of view, viz.—

- (a) Real or net silk spinners and throwsters.
- (b) Waste silk spinners.
- (c) Weaving factories.

**Real or Net Silk Spinners and Throwsters.** This class of factory is often referred to as a spinning mill, but this is a misnomer, as the actual spinning of net silk is done by the silkworm. Such a factory has machinery to enable the thread to be manipulated, and the processes from a fire insurance point of view are simple, whilst the machinery presents no special feature of hazard. The rooms are generally clean and well lighted. The silk is unwound from the wet cocoons on to a reeling frame, several slender fibres being twisted to form a suitable thread, and a hank is thus made. The reel is generally heated internally by a small steam pipe to help to dry the thread. The hanks are then sorted and graded, and washed with soap in warm water; they are afterwards dried, and the method employed should be noted, as this is perhaps the chief fire risk in the whole factory. Steam-heated compartments are used as a rule, and the silk is generally hung in hank form on poles. These compartments are often timber partitioned off with wood floors, and unless care and cleanliness be exercised, there is an accumulation of fine dust on the floors and steam pipes. The pipes, which often contain live steam, will sometimes be found to be in actual contact with woodwork, and although it is difficult to persuade a mill owner that a steam pipe can cause a fire, there are many cases on record where a fire has occurred in this manner. The wood quickly becomes dry and absorbs oxygen freely, and its continued heating coupled with the presence of light dust, will result in

combustion. Again, the pipes are sometimes laid on the wood floor, and these should be slightly raised on metal blocks to prevent contact. In other mills where a boiler is used for steam power, an attic will often be found thereover (with a perforated iron floor) in which hank drying is carried on. If this room is lofty and clean and free from miscellaneous storage (which is not always the case) the fire risk from the drying is really no greater than when done in steam-heated compartments, but with the passage of time a good deal of dust and other refuse finds its way through the perforated iron floor on to the boiler crown, and this may eventually cause a fire. After drying, the silk is wound on to bobbins ready for spinning or throwing. There is really no special fire hazard attaching to these processes and the threads are merely strengthened by twisting. The doubling or folding machine follows, wherein several threads are joined by twisting to make a twofold or threefold yarn.

The yarn is later machine cleaned to clear it of straggling particles of fibre by being drawn past a finely set knife or rough surface, but gassing may be resorted to, and as this is largely carried on in waste silk mills, I will refer to it at a later stage. The next process is dyeing, which, being a wet process, hardly involves much danger of fire, but the inevitable drying of the yarn follows, and I have referred to the hazard attaching thereto already. Much of the dyed silk is sold in hank form for sewing purposes, but the remainder finds its way to the weaving factory, to which reference will later be made.

**Waste Silk Spinning.** This branch of the silk trade is now of so much importance, especially in view of the demand for cheap silk garments as compared with those made of expensive real or net silk, that these notes would

be incomplete without reference to its fire hazards. Such factories really spin silk from raw materials, and are equipped on similar lines to those which spin wool, cotton, or flax. They deal with pierced or broken cocoons (including the outside and inside layers of reeled cocoons) and the waste and entangled threads from the net silk factories, also occasionally silk rags. These materials are warehoused in bale, and in a raw state they do not present any more hazard than an ordinary dry goods warehouse. The initial machine processes of bale breaking and opening, however, are sometimes carried on in the warehouse, but it is recommended that these machines be installed in a separate building, as certain fire hazards are introduced thereby. The waste fibres arrive at the factory in pressed packed bales which are placed in a frame where a row of revolving teeth rip off the layers of silk, and the presence of some hard substance in the bale at an unattended machine would probably cause fire through friction with the metal teeth.

Other machines are the cocoon beater and cocoon opener, which respectively clean and tear up the cocoons ; these machines work at fairly rapid speeds, and any hard substance coming into contact with the beaters or spiked rollers might cause a fire. For the entangled bundles of waste silk fibre, an opening machine is used which tears out the knotted parts so that the materials can be worked in the subsequent processes in a fleecy form. The risk of friction is again present, and the number of foreign matters, such as stones, nails, pieces of wood, etc., which find their way into the bales of silk waste is surprising. These machines are often found in warehouses containing much valuable stock.

The cocoons and waste silk are now in the form of a fibre, which, however, contains a large percentage of

gum (used by the worm when making the cocoon), in addition to dust, dirt, and other undesirable matter. The fibre is therefore boiled in soap and water, or steeped, and from a fire risk point of view these processes do not interest us, but they are followed by the drying of the material by artificial heat, which presents a considerable fire hazard.

I have seen many devices for drying raw silk, and I regret to say that many of them are unsatisfactory. The commonest seems to be the old-fashioned method of placing the wet material on a perforated iron floor over the boiler, where it is turned over at intervals; another method is to place the silk on wire netting stretched over the boiler top. In each case there is an accumulation of dust on the boiler crown, and a fire will result sooner or later. Steam-heated compartments are also used, but to my mind the most efficient method of drying is by an enclosed metal machine warmed by steam-heated air, and in which the silk is placed on travelling lattices.

At this stage it is found that the lower grades of silk (particularly those from India and China) contain a large amount of straw, leaves, and grass, which it is impossible to wash out, and as it is necessary that these should be removed, carbonization is resorted to. The materials are steeped in dilute acid which attacks and converts into carbon the vegetable matter without damaging the silk fibre; high temperature drying follows, generally in an enclosed machine, and the carbon is then shaken out in the form of dust. In cases where silk rags are used, it is necessary to break these into fibre again, and a machine similar to a rag grinder is used. There is considerable fire risk attaching, especially if oil is used on the rags, and the presence of any hard substance will quickly cause friction. It is desirable

that such a machine be installed in a detached building, and not inside the main factory.

The next step is to straighten the fibre preparatory to working it into a strand, and dressing, filling, preparing, and spreading machines are used, also sometimes carding and combing. There is no special hazard attaching, but much fluff or "fly" is given off, and unless the walls and floors are swept regularly, accumulations of fluff and dust result, and this would help to quickly spread a fire. The strands of fibre are later worked in gilling, drawing, and roving machines, then spun and twisted into thread. There is no special hazard attaching to the processes, but they are invariably found in storied factories, often old, with wood floors, wood hoists, and staircases, and these, coupled with the greasy state of the floors, help to form a comparatively heavy risk. Not many of these mills were built for silk spinning, and some are badly fitted up with old-fashioned gearing and upright shaft, engine, and boiler houses inside (probably with silk drying over the boiler), and other adverse points, and these, along with the weight of the machinery on the various wooden floors, present features which considerably add to the likelihood of a total loss should a fire break out.

The gassing department is often separated from the mill because of the dusty nature of the process, but sometimes one of the floors of the mill is used for this process. The yarn as spun and twisted presents a hairy or ragged appearance, and to ensure smoothness of the thread it is passed rapidly through a naked gas flame, this process being known as gassing or singeing. The gassing frames contain a number of small gas jets, and the yarn is run through these (by being wound from one bobbin to another) sufficiently quickly to avoid catching fire, but if the machine should stop through any cause



the threads would be burnt through. This work presents a certain fire risk, but in addition the dust from the process generally covers the walls, and unless careful attention is given to cleanliness and the walls regularly swept, the room soon becomes untidy ; fans are used for exhausting the powdered particles of fine dust, but in the best of mills the gassing department is usually one of the dirtiest parts of the premises. The fans often get choked with dust, and they should be frequently lubricated. The yarns are next washed and dyed, and the subsequent hank drying has already been described.

**Weaving Factories.** This class of factory generally presents a clean appearance, firstly, because the silk is in the form of a definite yarn or thread, and secondly, because of the value of these threads and the completed cloth. The processes of winding, warping, sizing, and beaming are of a simple nature, generally carried on in well lighted rooms, and the weaving shed itself is usually a satisfactorily arranged place. Where, however, pattern and figured weaving is done, Jacquard looms are used, and as these contain much harness gear above them constructed of varnished strings, there is always the danger of a fire (especially if lighted by gas) which might quickly spread to the looms adjoining. Even when promptly extinguished, the resulting smoke and water damage is often serious. The finished cloth is subsequently washed and then dried, either in steam-heated compartments or in steam-heated tentering machines. There is no particular risk attaching if the arrangements are satisfactory, but it must be remembered that wherever drying by artificial heat is carried on there is fire hazard present. The steam pipes should always be examined to make sure that they are not in contact with woodwork or other combustible material, and any fans used should be lubricated at regular intervals.

**Artificial Silk.** This material does not come within the category of true silk, but it is now so freely used in textile mills that it should be mentioned here as being of a highly inflammable nature, in fact, it is produced from vegetable matter, and retains all the characteristics of that family.

**General Notes.** As previously mentioned, true silk by itself is incombustible, and is the least dangerous of all the fibres, in fact, it will withstand a temperature up to 300° F. without change. Silk drying rooms, in consequence, are generally kept at a fairly high temperature, and fires have often been caused through the presence of foreign matter, such as vegetable fibres, which should not be subjected to such heat, and which have ignited. Many of the lower class mills do not go to the trouble of carbonizing the raw materials, and much inferior matter is permanently mixed with the silk. This is undesirable when it is remembered that the silk fibre, being solid, retains the heat for quite a long time after being removed from the drying chamber. Other fires have been thought to have been caused through the spontaneous combustion of "loading" materials. It is interesting to note that silk can be adulterated or "loaded" up to 300 per cent of its own weight with chemicals, such as mineral salts, fats, and other compounds mostly containing tannin, and it is difficult to determine the extent of the risk involved in their use. A wise surveyor will, therefore, inquire regarding the nature of the compounds used, but even then the insurance companies have little or no control over these.

In conclusion, I would mention that many of the "common" hazards are found in silk mills just as much as in other classes of factory. These are defective lighting and heating arrangements; inattention to the

regular oiling of the machinery and shafting ; the crowding of machinery into non-fireproof mills of four, five, and six stories ; the non-removal of waste materials, especially of greasy waste and cloths used for cleaning machinery ; the presence of rope races inside the mill ; and the faulty construction of extensions (generally of timber) coupled with the use of wood for the linings of the mill rooms and engine houses. All of these features present much greater hazards to the insurance companies than the actual manipulation of the silk fibre. At least two silk mills, to my knowledge, have been destroyed through faulty gearing in timber enclosed rope drives. Friction was set up which eventually fired the cotton driving ropes, and before the engine could be stopped the flames had passed from the bottom to the top floor of the mill. The interiors of these rope drives are coated with grease, whilst the ropes themselves are always oily, and they present a real menace. When the machinery is standing I have known a fire be caused through the use of a flare lamp by an engineer carrying out repairs to the gearing and accidentally setting fire to the cotton driving ropes. Another fire occurred in a drying room over the boiler, and spread to the mill adjoining. Fires always thrive in warm rooms, and a silk drying compartment with its dry woodwork is a likely place to help to spread a blaze once an outbreak occurs.



# INDEX

- ACT for protecting silk workers, 105
- Adulteration of silk, 119
- Affinity for water, 83
- America, large buyers of raw silk, 121
- Anaphe, curious species of, 15
- Ancient weaving, 63
- Annual production, 2
- Antheræa Mylitta, 16
- Pernyi, 14
- Yama-Mai, 14
- Aristotle, *History of Animals*, 5, 17
- Atlas moth, 14; silk of little value, 14
- Automatic weaving, 66
- BALLOON silk, material used for, 60
- Berlin Museum, textile treasures in, 100
- Blood, Edmund, 112
- Bombyx Mori, 5; life story of, 8; its brief duration, 11
- Book of Druggs*, 31
- Brocaded silk webs, 61
- Brocading metal webs, 61
- Bushell, Dr., 34, 75, 99
- CENTRES of manufacture, 121
- Chemical composition, 2
- China, 17; the home of silk, 19; secret carefully preserved by, 20; use of silk in, 65; first inventors of weaving, 69; large trade in webs, 72; magnificence of silk made in, 73; modern China (*cont.*)—
- indebtedness to, 78; draw-loom weavers, 92; another Chinese invention, 94; delicate work, 99
- Classification of dyes, 58
- Cleaning silk thread, 41; machines used for, 41
- Climate for sericulture, 27
- Cocoon, the, 10; the breaking of, 11; the formation of, 28
- Comber Board, the, 80; in use, 81
- Commercial value, 2
- Corea, Conventionalism of, 99
- Crossieur, 36
- Curse of modern art, the, 76
- DAMASK harness and monture, the working of, 96; meaning of, 107
- Diaper weaving, 86
- Dionysius Perigates, 2
- Diseases of silkworms, 29
- Double-harness weaving, 87
- objects and results of, 90
- Doubling and folding, 44
- Draughting on ruled paper, 116
- Draw-loom, the, 79; its most essential part, 79; leashes, of, 80; parts of, 81; automatic arrangement, 83; the loom tail, 84; the simple, 84; first in England, 111
- Dyeing, 48; method of, 49; the dye barc, 50; requisitions for, 50; turning the skeins, 52; the mordant,

- Dyeing (*cont.*)—  
 52; wringing, 53; re-winding  
 after, 58
- Dyes, laws relating to, 57;  
 classification of, 58; test  
 for, 58
- EAST, style of ornamentation  
 in the, 99
- Electricity, coming use of, 119
- Embroidery, silk used for, 61
- England, sericulture in, 23;  
 prospects of, 24; introduc-  
 tion of silk into, 105; early  
 embroidery, 105
- Excellence of Italian weaving,  
 117
- FARMS, requisite fittings, 26;  
 silkworm eggs, preparation  
 for hatching, 28
- Fibre, fineness of, 3; strength  
 of, 4; reeling from cocoons,  
 32
- Fibroin, 2; its appearance  
 after boiling, 3; how it is  
 made and stored, 8
- Flier, the, 42
- France, first weavers in, 109;  
 character of webs woven in,  
 110
- Friction wheel, the, 39; ut-  
 most importance of, 39
- Fly-shuttle, invention of, 115
- HAND-LOOMS, superiority of,  
 114; small number of, 115
- Hard silk, uses for, 59
- Harness-weaving, 87; method  
 of, 87
- Headle satin, 71
- Herodotus, 20
- Holland, persecution of weav-  
 ers in, 111
- Homer's *Odyssey*, 101
- INDIA, large supply from, 12;  
 Tusser silk, 12; introduc-  
 tion of silk into, 21; the  
 woven art of, 100
- Italy, flourishing industry in,  
 24; weaving in, 102; devel-  
 opment from, 107; excel-  
 lence of weaving in, 107;  
 isolation of, 108
- JACQUARD Machine, the, 115;  
 early objection to, 116;  
 principal advantage of, 117
- Japan, introduction into, 21;  
 conventionalism in, 100
- Justinian, Emperor, 22
- KAY, John, inventor of the  
 fly-shuttle, 115
- LAW relating to dyes, 57
- Livery companies, formation  
 of, 112
- Lombe, John, pioneer of silk-  
 throwing, 46
- Loom for pattern-weaving, 76;  
 its mechanism, 76; its  
 construction, 77; the loom-  
 tail, 83; superiority of  
 hand-loom, 114
- Lyons, supremacy of, 112
- MEDIAEVAL craftsmen, condi-  
 tion of, 56
- Metallic wefts, 61
- Mills, silk throwing, 47
- Modern weaving, 65; begin-  
 ning of, 114
- Mordanting, process of, 52
- Mulberry tree, the cultivation  
 of, 25; its importance, 25
- ORGANZINE, use for, 60
- Oriental silk weaving, speci-  
 mens of, 101
- PARASITIC fly, 29
- Persia, weaving in, 100
- IMPERIAL gifts of silks, 75
- Imported silk, value in 1686, 112

- Pliny, 20  
 Pomet, M., *History of Druggs*, 31  
 Power-loom, difficulties of the invention of, 114; inferiority to hand-loom, 114  
 Power-weaving, advantages and disadvantages of, 118
- REARING silkworms, 28  
 Reeling silk fibre, 32; care required in, 34; necessary processes, 35; machine for, 35; the Crossieur, 36; evenness of thread essential, 36  
 Re-winding dyed silk, 58  
 Richard II's embroidered coat, 111
- SATIN damask weaving, 94; working of damask-harness, 96; most perfect method, 98  
 Satin weaving, invention of, 69  
 — web intersection, 69  
 Serecin, 2; in the making, 10  
 Sericulture, antiquity of, 17; introduction to Europe, 22; spread of, 23; early enthusiasm in, 23; attempts to introduce into England, 23; great care needed for, 25; Government schools in France and Italy for, 29  
 Shuttlng, invention for, 115  
 Silk, importance and commercial value of, 1; chemical composition of, 2; distinct from other fibres, 3; source of supply, 4; Indian Tusser silk, 12; history of utilization of, 17; introduction into Japan, 21; into India, 21; wild silk cultivation, 26; specific gravity of, 45; dyeing, 48; twisting, 59; weaving, 62; use in China, 65; introduction into England, 105;
- Silk (*cont.*)—  
 trade in, 102; introduction into Spain, 104  
 Silk-producing moths, number of, 15; the Bombyx Mori, 8  
 Silkworm, the, 5; the structure and functions of, 6; the growth of, 8; the fibroin, 9; the transformation of, 10; Tusser silkworms, 13; natural home of, 17; first introduction into Europe, 22; its domestication in Italy, 23; the housing of, 26; farms and their fittings, 27; climate for, 27; rearing, 28; forming the cocoon, 28; diseases of, 29  
 Sizing by weight, 45  
 Skeining, method of, 46  
 Source of supply, 4  
 South Kensington Museum, treasures in, 106  
 Spain, introduction into, 104; characteristic designs of, 104  
 Spindle, the, 42  
 Spun silk, usefulness of, 47; superiority of, 121  
 Steaming, reason for, 45  
 Style of Eastern designs, 99  
 Swifts, the, 38  
 Syon Cope, the, 105
- TABBY weaving, 66  
 Technique of weaving, 62  
 — Damask weaving, 94  
 Throwing processes, 37; washing, 37; winding, 38; construction of Swifts, 38; the friction wheel, 39; cleaning the thread, 41; the throwing frame, 42; result after second throwing, 45; steaming and sizing, 45; skeining, 46; introduction of silk throwing, 46  
 Trade in silk, extensiveness of, 102

- Tram, usefulness of, 60  
 Transformation of silkworm, 10  
 Tice John, 112  
 Tusser silkworm, the, 12 ;  
   breeding, 13 ; silk impreg-  
   nated with tannin, 13  
 Twisting, various kinds of, 59
- UTILIZATION of silk, history  
 of, 17
- VARIETIES of silk moths, 12  
 Variety in colour of fibre,  
 cause of, 10  
 Velvet weaving, inventor un-  
 known, 106  
 Venice, introduction of weav-  
 ing into, 102
- WARDLE, Sir Thomas, 24  
 Washing the silk, 37
- Waste Silk, 121  
 Weaving, a prehistoric art, 62 ;  
 ancient and modern methods  
 of, 62 ; specimen of ancient,  
 63 ; materials used in, 64 ;  
 Tabby weaving, 66 ; the  
 mechanism of the loom, 66 ;  
 satin-web insertion, 69 ;  
 working, small designs, 79 ;  
 weaving in the East, 99 ; in  
 India, 100 ; in Italy, 102 ; in  
 Venice, 102 ; in Spain, 104 ;  
 in England, 105 ; decline in  
 18th century, 112 ; reasons  
 for, 113  
 W'Hang, Emperor, 19  
 Wild silk, cultivation of, 26  
 Winding machine, construc-  
 tion of, 38 ; method of  
 procedure, 40  
 Wringing (or scrouping), 53



# Books on Hand-Loom Weaving

By LUTHER HOOPER

## Hand-Loom Weaving

In small crown 8vo, artistically bound quarter cloth, 368 pp. ; 125 drawings by the author and Noel Rooke. Coloured and half-tone illustrations. Second Edition. Price 10s. 6d. net.

The author succeeds in describing every phase and process in weaving in a perfectly clear and exact manner. Helped as the text is by the author's sketches and diagrams, the reader should have no difficulty in conquering with its aid the rudiments of the craft.

## Weaving for Beginners

In foolscap 4to, 144 pp., with 62 diagrams and illustrations by the author. Price 5s. net.

With plain directions for making a hand loom, mounting it, and starting the work.

" Nothing that pen or pencil can contribute on the subject of hand-loom weaving seems to have been forgotten."—*Indian Textile Journal*.

## Weaving with Small Appliances

Each in foolscap 4to, with coloured and black-and-white illustrations. Price 7s. 6d. net each.

**Book I—The Weaving Board**

**Book II—Tablet Weaving**

**Book III—Table-Loom Weaving**

The appliances for weaving, and the instructions for using them, which are described in these books are specially designed for and adapted to the use of students, but at the same time the principles and processes are exactly the same as are used in commercial weaving. Coloured plates are used to illustrate the various patterns which may be woven on simple looms.

# Artificial Silk

In demy 8vo, with 117 illustrations. Price 21s. net.

By JOSEPH FOLTZER.

Translated into English by T. WOODHOUSE, *Head of the Weaving and Designing Department, Dundee Technical College.*

Third Edition.

This work in its French original is the standard work on the manufacture of this important fabric. The translation includes practically all that appeared in the French work, and also a considerable amount of information and new drawings concerning improvements that have recently taken place in the industry. The manufacture (spinning or drawing) of artificial silk yarns is explained and illustrated very fully; and the production of artificial silk ribbon, lace, cloth, leather, etc., is described in an interesting manner. It is a very complete treatise, and can be confidently recommended to all connected with the textile industry, and to research students and others in the chemical and physical laboratories of universities and colleges.

“The work is fully illustrated with excellent diagrams of the apparatus used. It is well written, and we can strongly recommend it to the notice of all who have to do with the manufacture of artificial silk.”—*Textile Manufacturer.*

## Dress, Blouse, and Costume Cloths

### Design and Fabric Manufacture

In demy 8vo, with 700 illustrations in monochrome and in colour.  
Price 42s. net.

By ROBERTS BEAUMONT, M.Sc., M.I.Mech.E.,  
*Textile Investigator and Expert*; and

WALTER G. HILL,

*Honours Medallist in Textile Technology, City and Guilds of London Institute.*

A complete exposition of the designing of the various fabrics covered by the title for students, manufacturers, designers, and experts. The object of the authors in compiling this treatise is to interpret (1) the commercial and industrial aspects of the trade; (2) the nature, structure, and the qualities of the yarns employed; (3) the weaving principles involved; (4) the design and colour schemes elaborated; and (5) the systems of fabric build and manufacture practised. A complete dissection of these problems has been attempted.

“In every way the treatment of the extensive and complicated subject is lucid, accurate, and adequate.”—*Yorkshire Observer.*

---

London: Sir Isaac Pitman & Sons, Ltd., Parker St., Kingsway, W.C.2

# A SELECTION FROM THE LIST OF COMMERCIAL HANDBOOKS

Published by

**SIR ISAAC PITMAN & SONS, LTD.**

*Complete Catalogue sent post free on application.*

*Obtainable through any Bookseller or direct from the Publishers*

**LONDON: PARKER STREET, KINGSWAY, W.C.2.**

**BATH: The Pitman Press. MELBOURNE: The Rialto, Collins St.**

**NEW YORK: 2 West 45th St. TORONTO: 70 Bond Street.**

**INDIA: A. H. Wheeler & Co., Bombay, Calcutta and Allahabad.**

*The Prices contained in this List apply only to the British Isles.*

## ARITHMETIC

PRICE

### **Arithmetic and Book-keeping.**

By THOS. BROWN, F.S.S., and VINCENT E. COLLINGE, A.C.I.S. In two parts. Part I . . . . . Net	2/6
Part II . . . . . Net	1/3

### **Arithmetic of Commerce.**

By P. W. NORRIS, M.A., B.Sc. (Hons.) . . . . . Net	4/-
--	-----

### **Business Calculations.**

By F. HEELIS, F.C.I.S. . . . . .	2/-
----------------------------------	-----

### **Complete Commercial Arithmetic.**

Answers . . . . . Net	1/6
-----------------------	-----

### **Complete Mercantile Arithmetic.**

By H. P. GREEN, F.C.Sp.T. (With Key) . . . . . Net	6/-
--	-----

### **Counting-House Mathematics.**

By H. W. PORRITT and W. NICKLIN, A.S.A.A. . . . . Net	2/-
---	-----

## Arithmetic—contd.

PRICE

<b>Elements of Commercial Arithmetic.</b>	Net	
By THOMAS BROWN . . . . .		2/-
<b>Metric and British System of Weights, Measures, and Coinage.</b>		
By DR. F. MOLLWO PERKIN . . . . .	Net	3/6
<b>Principles and Practice of Commercial Arithmetic.</b>		
By P. W. NORRIS, M.A., B.Sc. . . . .	Net	7/6
<b>Rapid Methods in Arithmetic.</b>		
By JOHN JOHNSTON. Revised and Edited by G. K. BUCKNALL, A.C.I.S. . . . .	Net	1/-
<b>Slide Rule Applied to Commercial Calculations, The.</b>		
By R. M. SHIREBY . . . . .	Net	2/6
<b>Smaller Commercial Arithmetic.</b>		
By C. W. CROOK, B.A., B.Sc. . . . .	Net	2/-

## BOOK-KEEPING AND ACCOUNTANCY

<b>Accountancy.</b>		
By F. W. PIXLEY, F.C.A., <i>Barrister-at-Law</i> . . . . .	Net	7/6
<b>Accountants' Dictionary.</b>		
Edited by F. W. PIXLEY, F.C.A. In 2 Vols. . . . .	Net	63/-
<b>Accounting.</b>		
By S. S. DAWSON, M.Com., F.C.A., and R. C. DE ZOUCHE, F.C.A. . . . .	Net	10/6
<b>Accounts of Executors, Administrators, and Trustees.</b>		
By WILLIAM B. PHILLIPS, A.C.A., A.C.I.S. . . . .	Net	5/-
<b>Advanced Accounts.</b>		
Edited by ROGER N. CARTER, M.Com., F.C.A. . . . .	Net	7/6
<b>Key to Advanced Accounts.</b>		
By R. A. GOODMAN . . . . .		20/-
<b>Advanced Book-keeping.</b>	Net	3/6
<b>Apportionment in Relation to Trust Accounts.</b>		
By A. F. CHICK, <i>Incorporated Accountant</i> . . . . .	Net	6/-
<b>Auditing, Accounting, and Banking.</b>		
By F. DOWLER, A.C.A., and E. M. HARRIS, A.I.B. . . . .	Net	7/6
<b>Auditors : Their Duties and Responsibilities.</b>		
By F. W. PIXLEY, F.C.A. . . . .	Net	21/-
<b>Balance Sheets. How to Read and Understand</b>		
By PHILIP TOVEY, F.C.I.S. . . . .	Net	2/6

## Book-keeping and Accountancy—contd.

	PRICE
<b>Bedrock of Double Entry Book-keeping, The.</b>	
By CHARLES W. WESTRON, <i>Chartered Accountant</i>	Net 1/-
<b>Book-keeper's Vade Mecum. The</b>	
By S. HOWARD WITHEY, A.L.A.A.	Net 3/6
<b>Book-keeping, A Course in.</b>	
By R. W. HOLLAND, O.B.E., M.A., M.Sc., LL.D.	Net 4/-
<b>Book-keeping and Commercial Practice.</b>	
By H. H. SMITH, F.C.T., F.Inc.S.T.	1/9
<b>Book-keeping for Beginners.</b>	
By W. E. HOOPER, A.C.I.S.	Net 2/-
<b>Book-keeping for Bootmakers, Retailers, etc.</b>	
By F. W. WHITFIELD	Net 3/6
<b>Book-keeping for Commercial and Secondary Schools.</b>	
By C. H. KIRTON, A.C.I.S.	Net 3/6
<b>Book-keeping for Retailers.</b>	
By H. W. PORRITT and W. NICKLIN, A.S.A.A.	Net 2/-
<b>Book-keeping for Shopkeepers.</b>	
By J. GREIG, F.C.I.	Net 2/6
<b>Book-keeping, Modern Methods of.</b>	
By R. H. EPPS, <i>Chartered Accountant</i>	Net 4/-
<b>Book-keeping Teachers' Manual.</b>	
By C. H. KIRTON, A.C.I.S., F.Inc.S.T.	Net 7/6
<b>Branch Accounts.</b>	
By P. TAGGART, A.S.A.A.	Net 3/-
<b>Builders' Accounts and Costs.</b>	
By ROBERT G. LEGGE	Net 3/6
<b>Business Book-keeping.</b>	
By J. ROUTLEY	Net 3/6
<b>Commercial Goodwill.</b>	
By P. D. LEAKE, F.C.A.	Net 21/-
<b>Company Accounts.</b>	
By ARTHUR COLES, F.C.I.S.	Net 7/6
<b>Consignments, Account Sales, and Accounts Current.</b>	
By E. J. HAMMOND, A.C.I.S., A.L.A.A.	Net 5/-
<b>Cost Accounting.</b>	
By W. AINSWORTH, A.C.I.S., A.C.W.A.	Net 5/-
<b>Cost Accounting.</b>	
By W. B. LAWRENCE, C.P.A.	Net 21/-

## Book-keeping and Accountancy—contd.

	PRICE
<b>Cost Accounts in Principle and Practice.</b>	
By A. CLIFFORD RIDGWAY, F.C.A. . . . .	Net 5/-
<b>Cost Accounts for the Metal Industry.</b>	
By H. E. PARKES, M.Com., A.C.W.A. . . . .	Net 10/6
<b>Costing and Price Fixing.</b>	
By J. M. SCOTT-MAXWELL, B.Sc. . . . .	Net 6/-
<b>Costing, A Primer of</b>	
By R. J. H. RYALL, F.C.W.A. . . . .	Net 5/-
<b>Costing, Dictionary of.</b>	
By R. J. H. RYALL, F.C.W.A. . . . .	Net 10/6
<b>Costing, Theory and Practice of</b>	
By E. W. NEWMAN, A.C.A. . . . .	Net 8/6
<b>Depreciation and Wasting Assets.</b>	
By P. D. LEAKE, F.C.A. . . . .	Net 15/-
<b>Dictionary of Book-keeping.</b>	
By R. J. PORTERS . . . . .	Net 7/6
<b>Full Course in Book-keeping.</b>	
By H. W. PORRITT and W. NICKLIN, A.S.A.A. . . . .	Net 5/-
<b>Higher Book-keeping and Accounts.</b>	
By H. W. PORRITT and W. NICKLIN, A.S.A.A. . . . .	Net 5/-
<b>Hotel Book-keeping.</b>	Net 2/6
<b>How to Become a Qualified Accountant.</b>	
By R. A. WITTY, F.S.A.A. . . . .	Net 3/6
<b>Manual of Book-keeping and Accountancy.</b>	
By A. NIXON, F.C.A., and H. E. EVANS, A.C.A. . . . .	Net 10/6
<b>Manual of Cost Accounts.</b>	
By H. JULIUS LUNT, F.C.A., A.C.I.S., F.C.W.A. . . . .	Net 7/6
<b>Notes of Lessons on Book-keeping.</b>	
By J. ROUTLEY . . . . .	Net 3/6
<b>Practical Book-keeping.</b>	
By G. JOHNSON, F.C.I.S. . . . .	Net 6/-
<b>Principles and Practice of Book-keeping and Accounts.</b>	
By B. G. VICKERY, A.C.A. . . . .	Net 12/6
<b>Principles of Auditing.</b>	
By F. R. M. DE PAULA, O.B.E., F.C.A. . . . .	Net 7/6
<b>Principles of Book-keeping Explained.</b>	
By I. H. HUMPHRYS . . . . .	Net 2/6
<b>Questions and Answers in Book-keeping and Accounting.</b>	
By F. F. SHARLES, F.S.A.A., . . . . .	Net 10/6
<b>Railway Accounts and Finance.</b>	
By ALLEN E. NEWHOOK, A.K.C. . . . .	Net 5/-

## Book-keeping and Accountancy—contd.

PRICE

### Shopkeepers' Accounts Simplified.

By C. D. CORNELL . . . . . Net 2/-

### Sinking Funds, Reserve Funds, and Depreciation.

By J. H. BURTON, A.S.A.A. . . . . Net 3/6

## BUSINESS TRAINING, ETC.

### Authorship and Journalism.

By ALBERT E. BULL . . . . . Net 3/6

### Business Handwriting.

Net 1/6

### Business Methods and Secretarial Work for Girls and Women.

By HELEN REYNARD, M.A. . . . . Net 2/6

### Commerce, Stage I.

By A. JAMES . . . . . 2/6

### Commercial Handwriting and Correspondence.

Net 2/6

### Commercial Practice.

By ALFRED SCHOFIELD . . . . . Net 3/6

### Counting-House Routine. 1st Year's Course.

By VINCENT E. COLLINGE, A.C.I.S. . . . . Net 1/9

### Counting-House Routine. 2nd Year's Course.

By VINCENT E. COLLINGE, A.C.I.S. . . . . Net 3/6

### Course in Business Training.

By G. K. BUCKNALL, A.C.I.S. . . . . 2/6

### Elements of Commerce.

By F. HEYWOOD, A.C.I.S. . . . . Net 4/-

### Game of Commerce, The.

By H. KENDRICK . . . . . Net 3/6

### How to Become an Auctioneer and Estate Agent. By W. F. NOKES, F.A.I. . . . .

Net 3/6

### How to Become a Private Secretary.

By J. E. McLACHLAN, F.I.P.S. . . . . Net 3/6

### How to Enter the Mercantile Marine.

By R. A. FLETCHER . . . . . Net 3/6

### How to Write a Good Hand.

By B. T. B. HOLLINGS . . . . . Net 1/6

### Junior Woman Secretary.

By ANNIE E. DAVIS, F.Inc.S.T. . . . . Net 2/-

### Manual of Business Training.

Net 4/-

## Business Training—contd.

	PRICE
<b>Modern Business and Its Methods.</b>	
By W. CAMPBELL, Chartered Secretary. . . . .	Net 7/6
<b>Popular Guide to Journalism.</b>	
By A. KINGSTON . . . . .	Net 2/6
<b>Practical Journalism and Newspaper Law.</b>	
By A. BAKER, M.J.I., and E. A. COPE . . . . .	Net 3/6
<b>Principles and Practice of Commerce.</b>	
By JAMES STEPHENSON, M.A., M.Com., D.Sc. . . . .	Net 8/6
<b>Principles of Business.</b>	
By JAMES STEPHENSON, M.A., M.Com., D.Sc. Part I, Net 2/6; . . . . . Part II,	Net 3/6
<b>Routine of Commerce.</b>	
By ALFRED SCHOFIELD, B.Sc. (Econ). . . . .	Net 4/-
<b>Short Story Writing and Free Lance Journalism.</b>	
By S. A. MOSELEY . . . . .	Net 7/6
<b>Theory and Practice of Commerce.</b>	
Edited by F. HEELIS, F.C.I.S. . . . .	Net 7/6
<b>Traders and Trading.</b>	
By W. J. WESTON, M.A., B.Sc. . . . .	Net 2/6

### CIVIL SERVICE

<b>Civil Service Arithmetic Tests.</b>	
By P. J. VARLEY-TIPTON . . . . .	Net 2/6
<b>Civil Service Essay Writing.</b>	
By W. J. ADDIS, M.A. . . . .	Net 2/6
<b>Civil Service Guide.</b>	
By A. J. LAWFORD JONES . . . . .	Net 2/6
<b>Civil Service Practice in Précis Writing.</b>	
Edited by ARTHUR REYNOLDS, M.A. (Oxon) . . . . .	Net 2/6
<b>Civil Servant and His Profession. The</b>	Net 3/6
<b>Copying Manuscript, Orthography, Hand-writing, Etc.</b>	
By A. J. LAWFORD JONES. . . . .	Net 3/6
<b>Digesting Returns into Summaries.</b>	
By A. J. LAWFORD JONES . . . . .	Net 2/6
<b>Elementary Précis Writing.</b>	
By WALTER SHAWCROSS, B.A. . . . .	Net 2/-
<b>Guide to Indexing and Précis Writing.</b>	
By W. J. WESTON, M.A., B.Sc., and E. BOWKER . . . . .	Net 2/-
<b>Indexing and Précis Writing.</b>	
By A. J. LAWFORD JONES . . . . .	Net 2/6



# ENGLISH AND COMMERCIAL CORRESPONDENCE

	PRICE
<b>Business Letters in English.</b>	
By W. J. WESTON, M.A., B.Sc. . . . . Net	3/6
<b>Commerce and Correspondence.</b>	
By E. H. GROUT, B.Sc. (Econ.) . . . . . Net	5/-
<b>Commercial Correspondence and Commercial English.</b>	
Net	3/6
<b>Commercial Dictionary.</b>	
Net	1/6
<b>Common-sense English.</b>	
By R. W. HOLLAND, M.A., M.Sc., LL.D. . . . .	1/6
<b>Correspondence of Commerce, The</b>	
By A. RISDON PALMER, B.Sc., B.A. . . . . Net	4/-
<b>English Composition and Correspondence.</b>	
By J. F. DAVIS, D.Lit., M.A., LL.B. (Lond.) . . . . . Net	2/-
<b>English for Commercial Students.</b>	
By H. W. HOUGHTON . . . . . Net	2/6
<b>English Grammar and Composition.</b>	
By W. J. WESTON, M.A., B.Sc. (Lond.) . . . . . Net	4/6
<b>English Grammar, Composition and Correspondence</b>	
By M. ALDERTON PINK, M.A. (Lond.) Net	8/6
<b>English Mercantile Correspondence.</b>	
Net	3/6
<b>English Prose Composition.</b>	
By W. J. WESTON, M.A., B.Sc. (Lond.) . . . . . Net	3/6
<b>Essentials of Speech.</b> By JOHN R. PELSMA . . . . . Net	7/6
<b>Guide to Commercial Correspondence and Business Composition.</b>	
By W. J. WESTON, M.A., B.Sc. (Lond.) . . . . .	2/6
<b>How to Teach Commercial English.</b>	
By WALTER SHAWCROSS, B.A. . . . . Net	3/6
<b>Manual of Commercial English.</b>	
By WALTER SHAWCROSS, B.A. . . . . Net	3/6
<b>Manual of Punctuation.</b> By W. D. WEBSTER . . . . .	1/-
<b>Pocket English Dictionary.</b>	
Net	1/6
<b>Principles and Practice of Commercial Correspondence.</b> By J. STEPHENSON, M.A., M.Com. Net	7/6
<b>Punctuation as a Means of Expression.</b>	
By A. E. LOVELL, M.A. . . . . Net	1/-
<b>Synonyms and Antonyms, Pitman's Book of.</b>	
Net	2/6

# COMMERCIAL GEOGRAPHY AND

## HISTORY

		PRICE
Commercial Atlas of the World.	Net	5/-
Commercial Geography of the British Empire Abroad and Foreign Countries.	Net	3/-
Commercial Geography of the British Isles.	Net	2/6
Commercial Geography of the World.	Net	4/6
Commercial History.		
By J. R. V. MARCHANT, M.A.	Net	5/6
Elements of Commercial Geography.		
By C. H. GRANT, M.Sc., F.R.Met.Soc.	Net	2/-
Elements of Commercial History.		
By FRED HALL, M.A., B.Com., F.C.I.S.	Net	2/-
Geography of Commerce, The.		
By W. P. RUTTER, M.Com.	Net	5/-
History of Commerce, The.		
By T. G. WILLIAMS, M.A., F.R.Hist.S., F.R.Econ.S.	Net	5/-
Principles of Commercial History.		
By J. STEPHENSON, M.A., M.Com., D.Sc.	Net	7/6
World and Its Commerce, The	Net	2/6

## ECONOMICS

British Finance (1914-1921).		
Edited by A. W. KIRKALDY, M.A., B.Litt., M.Com.	Net	15/-
British Labour (1914-1921).		
Edited by A. W. KIRKALDY, M.A., B.Litt., M.Com.	Net	10/6
Dictionary of Economic and Banking Terms.		
By W. J. WESTON, M.A., B.Sc., and A. CREW	Net	5/-
Economic Geography.		
By JOHN MCFARLANE, M.A., M.Com.	Net	10/6
Economic Geography, The Principles of		
By R. N. RUDMOSE BROWN	Net	7/6
Economics for Business Men		
By W. J. WESTON, M.A., B.Sc.	Net	3/6
Economics for Everyman.		
By J. E. LE ROSSIGNOL	Net	5/-
Economics of Private Enterprise, The.		
By J. H. JONES, M.A.	Net	7/6

## Economics—contd.

	PRICE
<b>Economics : Principles and Problems.</b>	
By L. D. EDIE . . . . .	Net 15/-
<b>Elements of Economics</b>	
By S. EVELYN THOMAS, B.Com. (Lond.) . . . . .	Net 10/6
<b>Elements of Political Economy.</b>	
By H. HALL, B.A. . . . .	Net 2/-
<b>Guide to Political Economy.</b>	
By F. H. SPENCER, D.Sc., LL.B. . . . .	Net 3/6
<b>Introduction to Sociology and Social Problems.</b>	
By W. G. BEACH . . . . .	Net 6/-
<b>Labour, Capital and Finance.</b>	
By "SPECTATOR" (W. W. WALL, F.J.I., F.S.S.) . . . . .	Net 3/6
<b>Main Currents of Social and Industrial Change, 1870-1924.</b>	
By T. G. WILLIAMS, M.A. . . . .	Net 5/-
<b>National Economics.</b>	
By E. BATTEN . . . . .	Net 5/-
<b>Outlines of Central Government.</b>	
By JOHN J. CLARKE, M.A., F.S.S. . . . .	Net 2/6
<b>Outlines of Industrial and Social Economics.</b>	
By JOHN J. CLARKE, M.A., F.S.S., and JAMES E. PRATT, A.C.I.S. . . . .	Net 1/6
<b>Outlines of Local Government.</b>	
By JOHN J. CLARKE, M.A., F.S.S. . . . .	Net 2/6
<b>Outlines of the Economic History of England.</b>	
By H. O. MEREDITH, M.A., M.Com. . . . .	Net 7/6
<b>Plain Economics.</b>	
By JOHN LEE, M.A., M.Com.Sc. . . . .	Net 3/6
<b>Social Administration.</b>	
By JOHN J. CLARKE, M.A., F.S.S. . . . .	Net 7/6
<b>Substance of Economics, The</b>	
By H. A. SILVERMAN, B.A. . . . .	Net 6/-

## BANKING AND FINANCE

<b>Banker as a Lender, The.</b>	
By F. E. STEELE . . . . .	Net 5/-
<b>Bankers' Advances.</b>	
By F. R. STEAD. Edited by SIR JOHN PAGET, K.O. . . . .	Net 6/-
<b>Bankers' Advances Against Produce.</b>	
By A. WILLIAMS, A.I.B. . . . .	Net 6/-

## Banking and Finance—contd.

		PRICE
<b>Bankers' Credits.</b> By W. F. SPALDING	Net	10/6
<b>Bankers' Securities Against Advances.</b> By LAWRENCE A. FOGG, Cert. A.I.B.	Net	6/-
<b>Bankers' Clearing House. The</b> By P. W. MATTHEWS	Net	7 6
<b>Bankers' Tests.</b> By F. R. STEAD	Net	10/6
<b>Bank Organization, Management, etc.</b> By J. F. DAVIS, M.A., D.Lit., LL.B. (Lond.)	Net	6/-
<b>Cheques.</b> By C. F. HANNAFORD	Net	6/-
<b>Dictionary of Banking.</b> By W. THOMSON and LLOYD CHRISTIAN	Net	30/-
<b>Eastern Exchange.</b> By W. F. SPALDING	Net	15/-
<b>Elements of Banking.</b> By J. P. GANDY	Net	2/-
<b>English Banking Administration, An Outline of.</b> By JOSEPH SYKES, B.A. (Hons.)	Net	2/6
<b>English Banking Methods.</b> By H. LE M. MINTY, Ph.D., B.Sc., B.Com.	Net	15/-
<b>English Public Finance.</b> By HARVEY E. FISK	Net	7/6
<b>Foreign Exchange and Foreign Bills in Theory and in Practice.</b> By W. F. SPALDING,	Net	7/6
<b>Foreign Exchange. A Primer of</b> By W. F. SPALDING	Net	3/6
<b>Foreign Trade, The Finance of.</b> By W. F. SPALDING	Net	7/6
<b>Functions of Money. The</b> By W. F. SPALDING	Net	7/6
<b>How to Succeed in a Bank.</b> By F. F. STEELE	Net	3/6
<b>International Trade Finance.</b> By G. W. EDWARDS, Ph.D.	Net	10/6
<b>London Money Market, The</b> By W. F. SPALDING	Net	10/6
<b>Modern Finance and Industry.</b> By A. S. WADE	Net	5/-
<b>Money and the Stock and Share Markets.</b> By EMIL DAVIES	Net	2/-
<b>Money, Exchange, and Banking.</b> By H. T. EASTON, A.I.B.	Net	6/-
<b>Notes on Banking and Commercial Law.</b> By T. LLOYD DAVIES	Net	3/-

## Banking and Finance—contd.

	PRICE
<b>Practical Banking.</b>	
By J. F. G. BAGSHAW, Cert. A.I.B. . . . .	Net 7/6
<b>Talks on Banking to Bank Clerks.</b>	
By H. E. EVANS . . . . .	Net 2/6
<b>Title Deeds and Real Property Law.</b>	
By F. R. STEAD . . . . .	Net 6/-

## INSURANCE

<b>Actuarial Science, The Elements of</b>	
By R. E. UNDERWOOD, M.B.E., F.I.A. . . . .	Net 5/-
<b>Business Man's Guide to Insurance, The</b>	
By A. PHILPOTT . . . . .	Net 3/6
<b>Compound Interest, Principles of</b>	
By H. H. EDWARDS . . . . .	Net 5/-
<b>Credit Risks. Commercial</b> By G. H. SWAIN	Net 5/-
<b>Fire Insurance, Common Hazards of</b>	
By W. G. KUBLER RIDLEY, F.C.I.I. . . . .	Net 5/-
<b>Fire Insurance, Principles and Practice of</b>	
By F. GODWIN . . . . .	Net 5/-
<b>Guide to Life Assurance.</b>	
By S. G. LEIGH, F.I.A. . . . .	Net 5/-
<b>Guide to Marine Insurance.</b>	
By HENRY KEATE . . . . .	Net 3/6
<b>Insurance.</b> By T. E. YOUNG, B.A., F.R.A.S., W. R. STRONG, F.I.A., and VYVYAN MARR, F.F.A., F.I.A.	Net 10/6
<b>Insurance Office Organization, Management, and Accounts.</b> By T. E. YOUNG, B.A., F.R.A.S., and RICHARD MASTERS, A.C.A. . . . .	Net 6/-
<b>Insurance of Public Liability Risks.</b>	
By S. V. KIRKPATRICK, F.C.I.I. . . . .	Net 5/-
<b>Law and Practice as to Fidelity Guarantees.</b>	
By C. EVANS and F. H. JONES . . . . .	Net 6/-
<b>Life Assurance from Proposal to Policy.</b>	
By H. HOSKING TAYLOR, F.I.A., A.C.I.I., and V. W. TYLER, F.I.A. . . . .	Net 6/-
<b>Motor Insurance.</b> By W. F. TODD . . . . .	Net 6/-
<b>Pension, Endowment, Life Assurance, and Other Schemes for Commercial Companies.</b>	
By H. DOUGHARTY, F.C.I.S. . . . .	Net 6/-
<b>Personal Accident, Disease, and Sickness Insurance, The Principles and Practice of</b>	
By J. B. WELSON, LL.M. . . . .	Net 5/-

## Banking and Finance—contd.

PRICE

<b>Physiology and Anatomy.</b>		
By H. GARDINER, M.S., F.R.C.S.	Net	10/6
<b>Principles of Insurance.</b> By J. ALFRED EKE	Net	5/-
<b>Successful Insurance Agent, The</b>		
By J. J. BISGOOD, B.A., F.C.I.S., J.P.	Net	2/6
<b>Talks on Insurance Law.</b>		
By J. A. WATSON, B.Sc., LL.B.	Net	3/6
<b>Workmen's Compensation Insurance.</b>		
By C. E. GOLDING, LL.B., F.C.I.I.	Net	5/-

## SHIPPING

<b>Case and Freight Costs.</b>		
By A. W. E. CROSFIELD	Net	2/-
<b>Consular Requirements for Exporters and Shippers to all Parts of the World.</b>		
By J. S. NOWERY	Net	7/6
<b>Exporters' Handbook and Glossary, The</b>		
By F. M. DUDENEY	Net	7/6
<b>Exporting to the World.</b> By A. A. PRECIADO	Net	21/-
<b>How to Export Goods.</b> By F. M. DUDENEY	Net	2/-
<b>How to Import Goods.</b> By J. A. DUNNAGE	Net	2/-
<b>Import and Export Trade.</b>		
By A. S. HARVEY	Net	21/-
<b>Importer's Handbook, The</b>		
By J. A. DUNNAGE	Net	10/6
<b>Shipbroking.</b>		
By C. D. MACMURRAY and M. M. CREE	Net	3/6
<b>Shipper's Desk Book, The</b>		
By J. A. DUNNAGE	Net	3/6
<b>Shipping.</b> By A. HALL and F. HEYWOOD	Net	2/-
<b>Shipping and Shipbroking.</b>		
By C. D. MACMURRAY and M. M. CREE	Net	15/-
<b>Shipping Business Methods.</b> By R. B. PAUL	Net	3/6
<b>Shipping Finance and Accounts.</b>		
By R. B. PAUL	Net	2/6
<b>Shipping Office Organization, Management, and Accounts.</b> By ALFRED CALVERT	Net	6/-
<b>Shipping Terms and Phrases.</b>		
By J. A. DUNNAGE	Net	2/6

## SECRETARIAL WORK, ETC.

	PRICE
<b>Chairman's Manual.</b>	
By GURDON PALIN, of <i>Gray's Inn</i> , <i>Barrister-at-Law</i> , and ERNEST MARTIN, F.C.I.S. . . . .	Net 5/-
<b>Company Registrar's Manual, The</b>	
By J. J. QUINLIVAN . . . . .	Net 10/6
<b>Company Secretarial Work.</b>	
By E. MARTIN, F.C.I.S. . . . .	Net 2/-
<b>Company Secretary's Vade Mecum.</b>	
Edited by P. TOVEY, F.C.I.S. . . . .	Net 3/6
<b>Debentures.</b>	
By F. SHEWELL COOPER, M.A., <i>Barrister-at-Law</i>	Net 6/-
<b>Dictionary of Secretarial Law and Practice.</b>	
Edited by PHILIP TOVEY, F.C.I.S. . . . .	Net 42/-
<b>Examination Notes on Secretarial Practice.</b>	
By C. W. ADAMS, A.C.I.S. . . . .	Net 2/6
<b>Guide for the Company Secretary.</b>	
By ARTHUR COLES, F.C.I.S. . . . .	Net 6/-
<b>Guide to Company Secretarial Work.</b>	
By O. OLDHAM, A.C.I.S. . . . .	Net 3/6
<b>Honorary Secretaryship.</b>	
By W. B. THORNE . . . . .	Net 2/6
<b>How to Become a Company Secretary.</b>	
By E. J. HAMMOND, A.C.I.S. . . . .	Net 3/6
<b>How to Become a Private Secretary.</b>	
By J. E. MCLACHLAN . . . . .	Net 3/6
<b>How to Take Minutes.</b>	
Edited by E. MARTIN, F.C.I.S. . . . .	Net 2/6
<b>Income Tax and Super-Tax Practice.</b>	
Dictionary of. By W. E. SNELLING . . . . .	Net 25/-
<b>Income Tax and Super-Tax, Principles and Practice of.</b>	
By HALFORD W. L. REDDISH, A.C.A., and H. G. W. TEVERSON, A.C.A. . . . .	Net 11/6
<b>Income Tax, Practical</b>	
By W. E. SNELLING	Net 3/6
<b>Income Tax Relief, Double</b>	
By H. E. SEED and A. W. RAWLINSON . . . . .	Net 10/6
<b>Limited Liability Companies.</b>	
By R. ASHWORTH, A.A.C. . . . .	Net 10/6
<b>Meetings.</b>	
By F. D. HEAD, B.A. . . . .	Net 5/-

## Secretarial Work, etc.—contd.

	PRICE
<b>Outlines of Transfer Procedure in Connection with Stocks, Shares, etc.</b>	
By F. D. HEAD, B.A. (Oxon), <i>Barrister-at-Law</i> . . . . .	Net 3/6
<b>Practical Directorship.</b>	
By H. E. COLESWORTHY, A.S.A.A., and S. T. MORRIS, A.S.A.A. . . . .	Net 7/6
<b>Practical Share Transfer Work.</b>	
By F. W. LIDDINGTON . . . . .	Net 3/6
<b>Prospectuses : How to Read and Understand Them.</b> By PHILIP TOVEY, F.C.I.S. . . . .	Net 5/-
<b>Questions and Answers on Secretarial Practice.</b>	
By E. J. HAMMOND, A.C.I.S. . . . .	Net 7/6
<b>Secretary's Handbook.</b>	
Edited by SIR H. E. BLAIN, C.B.E. . . . .	Net 5/-
<b>Transfer of Stocks, Shares, and Other Marketable Securities.</b>	
By F. D. HEAD, B.A. . . . .	Net 10/6

## INDUSTRIAL ADMINISTRATION

<b>Employment Management.</b>	
Compiled and Edited by DANIEL BLOOMFIELD . . . . .	Net 8/6
<b>Engineering Factory Supplies.</b>	
By W. J. HISCOX . . . . .	Net 5/-
<b>Factory Administration in Practice.</b>	
By W. J. HISCOX . . . . .	Net 8/6
<b>Factory Lay-Out, Planning and Progress.</b>	
By W. J. HISCOX . . . . .	Net 7/6
<b>Fair Wage. A</b> By E. BATTEN . . . . .	Net 2/6
<b>Industrial Conflict.</b>	
By the RIGHT HON. GEORGE N. BARNES . . . . .	Net 3/6
<b>Industrial Control (Applied to Manufacture).</b>	
By F. M. LAWSON, A.M.I.C.E., A.M.I.Mech.E. . . . .	Net 8/6
<b>Industrial Organization.</b>	
By JOHN LEE, M.A., M.Com.Sc. . . . .	Net 5/-
<b>Introduction to Industrial Administration,</b>	
<b>An.</b> By J. LEE, C.B.E., M.A., M.Com.Sc. . . . .	Net 5/-
<b>Lectures on Industrial Administration.</b>	
Edited by B. MUSCIO, M.A. . . . .	Net 6/-
<b>Management.</b> By J. LEE . . . . .	Net 5/-



## Industrial Administration—contd.

	PRICE
<b>Modern Industrial Movements.</b>	
Edited by D. BLOOMFIELD . . . . .	Net 10/6
<b>Outlines of Industrial Administration.</b>	
By R. O. HERFORD, H. T. HILDAGE, and H. G. JENKINS . . . . .	Net 6/-
<b>Patents for Inventions.</b>	
By J. EWART WALKER, B.A., and R. B. FOSTER, B.Sc.	Net 21/-
<b>Philosophy of Management, The</b>	
By OLIVER SHELDON, B.A. . . . .	Net 10/6
<b>Principles of Industrial Administration, An Introduction to</b>	
By A. P. M. FLEMING, C.B.E., M.Sc., M.I.E.E., and H. J. BROCKLEHURST, M.Eng., A.M.I.E.E. . . . .	Net 3/6
<b>Principles of Industrial Welfare.</b>	
By J. LEE, M.A. . . . .	Net 5/-
<b>Problems of Labour.</b>	
Compiled and Edited by DANIEL BLOOMFIELD . . . . .	Net 8/6
<b>Psychology of Management, The</b>	
By L. M. GILBRETH . . . . .	Net 7/6
<b>Research in Industry.</b>	
By A. P. M. FLEMING, C.B.E., M.Sc., M.I.E.E., and J. G. PEARCE, B.Sc., A.M.I.E.E. . . . .	Net 10/6
<b>Sharing Profits With Employees.</b>	
By J. A. BOWIE, M.A. . . . .	Net 10/6
<b>Time Standardization of Workshop Operations.</b>	
By T. PILKINGTON . . . . .	Net 16/-
<b>Welfare Work in Industry.</b>	
Edited by E. T. KELLY . . . . .	Net 5/-
<b>Workshop Committees.</b> By C. G. RENOLD . . . . .	Net 1/-

## BUSINESS ORGANIZATION AND MANAGEMENT

<b>Business Management for Small Retailers.</b>	
By H. W. THEEDAM . . . . .	Net 3/6
<b>Card Index System.</b>	Net 2/-
<b>Colliery Office Organization and Accounts.</b>	
By J. W. INNES, F.C.A., and T. COLIN CAMPBELL, F.C.I. . . . .	Net 7/6
<b>Commercial Management.</b> By C. L. BOLLING . . . . .	Net 10/6

## Business Organization and Management—contd.

	PRICE
<b>Counting-House and Factory Organization.</b> By J. GILMOUR WILLIAMSON . . . . . Net	7/6
<b>Drapery Business Organization, Management, and Accounts.</b> By J. ERNEST BAYLEY . . . . . Net	7/6
<b>Filing Systems.</b> By E. A. COPE . . . . . Net	3/6
<b>Flour Milling Industry Organization and Management.</b> By E. L. PEARSON . . . . . Net	12/6
<b>Grocery Business Organization and Manage- ment.</b> By C. L. T. BEECHING and J. A. S MART . . . . . Net	6/-
<b>Hotel Organization, Management, and Accountancy.</b> By G. De BONI, Hotel Manager, and F. F. SHARLES, F.S.A.A., A.C.I.S. . . . . Net	10/6
<b>How to Grant Credit.</b> By CUTHBERT GREIG . . . . . Net	3/6
<b>How to Collect Accounts by Letter.</b> By C. HANNEFORD-SMITH . . . . . Net	3/6
<b>Manual of Duplicating Methods.</b> By W. DESBOROUGH . . . . . Net	3/-
<b>Office Machines, Appliances, and Methods.</b> By W. DESBOROUGH, F.C.I. . . . . Net	6/-
<b>Office Organization and Management, Includ- ing Secretarial Work.</b> By LAWRENCE R. DICKSEE, M.Com., F.C.A., and SIR H. E. BLAIN, C.B.E. . . . . Net	7/6
<b>Organization of a Small Business, The</b> By W. A. SMITH . . . . . Net	2/6
<b>Self-Organization for Business Men.</b> By MORLEY DAINOW, B.Sc. . . . . Net	5/-
<b>Solicitors' Office Organization, Management, and Accounts.</b> By E. A. COPE and H. W. H. ROBINS . . . . . Net	6/-
<b>Stockbroker's Office Organization, Manage- ment, and Accounts.</b> By J. E. DAY . . . . . Net	7/6

### MUNICIPAL WORK

<b>Local Government of the United Kingdom, The.</b> By J. J. CLARKE, M.A., F.S.S. . . . . Net	7/6
<b>Municipal Accounting Systems.</b> By S. WHITEHEAD, A.S.A.A., A.C.I.S. . . . . Net	5/-

## Municipal Work—contd.

	PRICE
<b>Municipal Audit Programmes.</b>	
By the Same Author . . . . .	Net 3/6
<b>Municipal Book-keeping.</b>	
By J. H. McCALL, F.S.A.A. . . . .	Net 7/6
<b>Municipal and Local Government Law.</b>	
By H. E. SMITH, LL.B. . . . .	Net 7/6
<b>Municipal Organization.</b> By M. H. COX, LL.B.	Net 5/-
<b>Organization and Administration of the Education Department.</b>	
By A. E. IKIN, B.Sc., LL.D. . . . .	Net 7/6
<b>Organization and Administration of the Electricity Undertaking.</b>	
By C. L. E. STEWART, M.I.E.E. . . . .	Net 6/-
<b>Organization and Administration of the Finance Department.</b>	
By W. BATESON, A.C.A., F.S.A.A. . . . .	Net 7/6
<b>Organization and Administration of the Gas Undertaking.</b> By E. UPTON, F.S.A.A.	Net 5/-
<b>Organization and Administration of the Public Health Department.</b>	
By W. A. LEONARD, <i>Chief Clerk and Statistician in the Public Health Department, Birmingham</i> . . . . .	Net 6/-
<b>Organization and Administration of the Town Clerk's Department and the Justices' Clerk's Department.</b>	
By A. S. WRIGHT and E. H. SINGLETON . . . . .	Net 7/6
<b>Organization and Administration of the Tramways Department.</b>	
By S. B. N. MARSH, <i>Accountant to the Birmingham Corporation Tramways</i> . . . . .	Net 6/-
<b>Organization and Administration of the Waterworks Department.</b>	
By F. J. ALBAN, F.S.A.A., F.I.M.T.A., A.C.I.S. . . . .	Net 10/6
<b>Principles of Organization.</b>	
By W. BATESON, A.C.A., F.S.A.A. . . . .	Net 3/6
<b><u>ADVERTISING AND SALESMANSHIP</u></b>	
<b>Ads. and Sales.</b> By HERBERT N. CASSON . . . . .	Net 8/6
<b>Advertising and the Shopkeeper.</b>	
By HAROLD W. ELEY . . . . .	Net 3/6

## Advertising and Salesmanship—contd.

	PRICE
<b>Advertising and Selling.</b>	
Edited by NOBLE T. PRAIGG . . . . .	Net 10/6
<b>Advertising Procedure.</b> By O. KLEPPNER . . . . .	Net 21/-
<b>Advertising Through the Press.</b>	
By N. HUNTER . . . . .	Net 5/-
<b>Business Man's Guide to Advertising.</b>	
By A. E. BULL . . . . .	Net 3/3
<b>Buying Goods.</b> By A. E. BULL . . . . .	Net 2/-
<b>Commercial Travelling.</b> By A. E. BULL . . . . .	Net 3/6
<b>Craft of Silent Salesmanship.</b>	
By C. MAXWELL TREGURTHA and J. W. FRINGS	Net 5/-
<b>Effective Postal Publicity.</b>	
By MAX RITTENBERG . . . . .	Net 7/6
<b>Efficient Salesmanship.</b>	
By F. W. SHRUBSALL . . . . .	Net 2/-
<b>Language of Advertising, The.</b>	
By J. B. OPDYCKE . . . . .	Net 15/-
<b>Lettering, Plain and Ornamental.</b>	
By E. G. FOOKS . . . . .	Net 3/6
<b>Mail Order and Instalment Trading.</b>	
By A. E. BULL . . . . .	Net 7/6
<b>Mail Order Business, Conducting a</b>	
By A. E. BULL . . . . .	Net 2/-
<b>Mail Order Organization.</b> By P. E. WILSON	Net 3/6
<b>Modern Methods of Selling.</b> By L. J. HOENIG	Net 10/6
<b>Modern Publicity.</b> By A. W. DEAN . . . . .	Net 2/6
<b>Outdoor Sales Force. The</b> By P. E. WILSON	Net 3/6
<b>Outline of Sales Management, An.</b>	
By C. C. KNIGHTS, <i>Sales Consultant</i> . . . . .	Net 5/-
<b>Practical Press Publicity.</b> By A. L. CULYER	Net 3/6
<b>Practical Salesmanship.</b>	
By N. C. FOWLER, assisted by 29 expert salesmen, etc.	Net 7/6
<b>Principles of Practical Publicity.</b>	
By TRUMAN A. DE WEESE . . . . .	Net 10/6
<b>Salesmanship.</b>	
By W. A. CORBION and G. E. GRIMSDALE . . . . .	Net 3/6

## Advertising and Salesmanship—contd.

	PRICE
<b>Storecraft.</b> By S. A. WILLIAMS, M.A. . . . Net	3/6
<b>Successful Retailing.</b> By E. N. SIMONS . . . . . Net	5/-
<b>Ticket and Showcard Designing.</b> By F. A. PEARSON . . . . . Net	3/6
<b>Training for More Sales.</b> By C. C. KNIGHTS, <i>Sales Consultant</i> . . . . . Net	5/-
<b>Training in Commercial Art.</b> By V. L. DANVERS . . . . . Net	21/-
<b>Window Dressing.</b> By G. L. TIMMINS . . . . . Net	2/-

## TRANSPORT

<b>History and Economics of Transport, The</b> By A. W. KIRKALDY, M.A., B.Litt., M.Com., and A. D. EVANS . . . . . Net	15/-
<b>How to Send Goods by Road, Rail, and Sea.</b> By G. B. LISSENDEN . . . . . Net	2/-
<b>Industrial Traffic Management.</b> By G. B. LISSENDEN . . . . . Net	21/-
<b>Modern Railway Operation.</b> By D. R. LAMB, M.Inst.T. . . . . Net	7/6
<b>Motor Road Transport.</b> By J. PHILLIMORE . . . . . Net	10/6
<b>Port Economics.</b> By B. CUNNINGHAM, D.Sc., B.E., F.R.S.E., M.Inst.C.E. . . . . Net	6/-
<b>Railway Rates : Principles and Problems.</b> By P. BURTT, M.Inst.T. . . . . Net	6/-
<b>Rights and Duties of Transport Undertakings.</b> By H. B. DAVIES, M.A. . . . . Net	5/-

## WORKS OF REFERENCE, ETC.

<b>Business Building.</b> Edited by F. F. CHARLES, F.S.A.A., A.C.I.S. 2 Vols. Net	42/-
<b>Business Man's Encyclopaedia.</b> Edited by J. A. SLATER, B.A., LL.B. Four Vols. Net	£4/4/-
<b>Business Man's Guide.</b> Edited by J. A. SLATER, B.A., LL.B. . . . . Net	6/-
<b>Business Statistics.</b> By R. W. HOLLAND, O.B.E., M.A., M.Sc., LL.D. Net	3/6

## Works of Reference, etc.—contd.

	PRICE
<b>Business Terms, Phrases, etc.</b> . . . . .	Net <b>3/6</b>
<b>Charting, Manual of</b> . . . . .	Net <b>6/-</b>
<b>Charts and Graphs.</b>	
By KARL G. KARSTEN, B.A. (Oxon) . . . . .	Net <b>25/-</b>
<b>Commercial Arbitrations.</b>	
By E. J. PARRY, B.Sc., F.I.C., F.C.S. . . . .	Net <b>3/6</b>
<b>Commercial Commodities.</b>	
By F. MATTHEWS, B.Sc., A.I.C., F.C.S. . . . .	Net <b>12/6</b>
<b>Commercial Contracts.</b> By E. J. PARRY . . . . .	Net <b>5/-</b>
<b>Commercial Self-Educator.</b>	
Edited by R. W. HOLLAND, O.B.E., M.A., M.Sc., LL.D. Two Vols. . . . .	Net <b>30/-</b>
<b>Commodities of Commerce.</b>	
By J. A. SLATER, B.A., LL.B. . . . .	Net <b>6/-</b>
<b>Dictionary of the World's Commercial Pro- ducts.</b> By J. A. SLATER, B.A., LL.B. (Lond.)	Net <b>3/</b>
<b>Discount, Commission, and Brokerage Tables.</b>	
By ERNEST HEAVINGHAM . . . . .	Net <b>1/6</b>
<b>Fruit and the Fruit Trade.</b>	
By F. FAIRFORD . . . . .	Net <b>6/-</b>
<b>Guide to the Improvement of the Memory.</b>	
By the late REV. J. H. BACON . . . . .	Net <b>1/6</b>
<b>History, Law, and Practice of the Stock Exchange, The</b>	
By A. P. POLEY, B.A., and F. H. GOULD . . . . .	Net <b>7/6</b>
<b>Investor's Manual, The</b>	
By W. W. WALL, F.S.S., F.J.I. . . . .	Net <b>3/6</b>
<b>Mercantile Terms and Abbreviations.</b> . . . . .	Net <b>1/6</b>
<b>Money and the Stock and Share Markets, The</b>	
By EMIL DAVIES . . . . .	Net <b>2/-</b>
<b>Public Speaking.</b> By F. H. KIRKPATRICK . . . . .	Net <b>5/-</b>
<b>Shareholder's Manual, The</b>	
By H. H. BASSETT . . . . .	Net <b>3/6</b>
<b>Statistical Methods.</b> By F. C. MILLS . . . . .	Net <b>15/-</b>

## LAW

		PRICE
<b>Bankruptcy, Deeds of Arrangement, etc.</b>		
By W. VALENTINE BALL, M.A., <i>Barrister-at-Law</i>	Net	12/6
<b>Bills, Cheques, and Notes.</b>		
By J. A. SLATER, B.A., LL.B.	Net	6/-
<b>Commercial Law of England, The</b>		
By J. A. SLATER, B.A., LL.B. (Lond.)	Net	3/6
<b>Companies and Company Law.</b>		
By A. C. CONNELL, LL.B. (Lond.)	Net	6/-
<b>Company Case Law.</b>		
By F. D. HEAD, B.A. (Oxon)	Net	7/6
<b>Company Law.</b>		
By H. FARRAR, M.C., M.A., LL.D.	Net	12/6
<b>Elements of Commercial Law, The</b>		
By A. H. DOUGLAS, LL.B. (Lond.)	Net	2/-
<b>Elementary Law.</b> By E. A. COPE	Net	4/-
<b>Examination Notes on Commercial Law.</b>		
By R. W. HOLLAND, O.B.E., M.A., M.Sc., LL.D.	Net	2/6
<b>Examination Notes on Company Law.</b>		
By R. W. HOLLAND, O.B.E., M.A., M.Sc., LL.D.	Net	2/6
<b>Guide to Company Law.</b>		
By R. W. HOLLAND, O.B.E., M.A., M.Sc., LL.D.	Net	3/6
<b>Guide to Railway Law.</b>		
By ARTHUR E. CHAPMAN, M.A., LL.D. (Camb.)	Net	7/6
<b>Guide to Bankruptcy Law.</b>		
By F. PORTER FAUSSET, B.A., LL.B., <i>Barrister-at-Law</i>	Net	3/6
<b>Guide to the Law of Licensing.</b>		
By J. WELLS THATCHER	Net	5/-
<b>Law for Journalists.</b>		
By CHARLES PILLEY, <i>Barrister-at-Law</i>	Net	5/-
<b>Law of Contract, The</b>		
By R. W. HOLLAND, M.A., M.Sc., LL.D.	Net	5/-
<b>Law of Repairs and Dilapidations.</b>		
By T. CATO WORSFOLD, M.A., LL.D.	Net	3/6
<b>Law Relating to Building and Contracts.</b>		
By W. T. CRESWELL, <i>Barrister-at-Law</i>	Net	7/6
<b>Law Relating to Secret Commissions and Bribes.</b>		
By ALBERT CREW, <i>Barrister-at-Law.</i>	Net	10/6

## Law—contd.

	PRICE
<b>Law Relating to Carriage by Land.</b>	
By S. W. CLARKE, <i>Barrister-at-Law</i> . . . . .	Net 7/6
<b>Law Relating to Trade Customs, Marks, etc.</b>	
By LAWRENCE DUCKWORTH, <i>Barrister-at-Law</i> . . . . .	Net 1/3
<b>Law and Accounts of Executors, Administrators, and Trustees.</b>	
By E. WESTBY-NUNN, B.A., LL.B. and B. G. VICKERY, F.C.A., F.C.I.S. . . . .	Net 12/6
<b>Legal Aspect of Commerce, The</b>	
By A. SCHOLFIELD, M.Com., A.C.I.S. . . . .	Net 7/6
<b>Legal Terms, Phrases, and Abbreviations.</b>	
By E. A. COPE . . . . .	Net 3/-
<b>Mercantile Law.</b>	
By J. A. SLATER, B.A., LL.B. (Lond.) . . . . .	Net 7/6
<b>Mercantile Law, Principles of</b>	
By E. W. CHANCE, O.B.E., LL.B. . . . .	Net 12/6
<b>Outlines of Company Law.</b>	
By F. D. HEAD, B.A. (Oxon) . . . . .	Net 2/6
<b>Partnership Law and Accounts.</b>	
By R. W. HOLLAND, O.B.E., M.A., M.Sc., LL.D. . . . .	Net 6/-
<b>Principles of Marine Law.</b>	
By LAWRENCE DUCKWORTH . . . . .	Net 7/6
<b>Questions and Answers on Commercial Law.</b>	
By R. W. HOLLAND . . . . .	Net 5/-
<b>Questions and Answers on Company Law.</b>	
By G. WILLIAM FORTUNE, F.S.A.A., F.C.I.S. (Hons.), and D. R. MATHESON, M.A. (Hons.), A.S.A.A. (Hons.) . . . . .	Net 5/-
<b>Railway Act, 1921, The.</b>	
By R. P. GRIFFITHS, F.C.I., F.B.E.A., Grad.Inst.T. . . . .	Net 2/6
<b>Railway (Rebates) Case Law.</b>	
By GEO. B. LISSENDEN . . . . .	Net 10/6
<b>Solicitor's Clerk's Guide.</b>	
By E. A. COPE . . . . .	Net 4/-
<b>Wills, Executors and Trustees.</b>	
By J. A. SLATER, B.A., LL.B. (Lond.) . . . . .	Net 2/6



# COMMON COMMODITIES AND INDUSTRIES

---

Each book in crown 8vo, illustrated. 3s. net.

In each of the handbooks in this series a particular product or industry is treated by an expert writer and practical man of business. Beginning with the life history of the plant, or other natural product, he follows its development until it becomes a commercial commodity, and so on through the various phases of its sale in the market and its purchase by the consumer.

## Acids, Alkalis, and Salts.

By G. H. J. ADLAM, M.A., B.Sc., F.C.S.

## Alcohol in Commerce and Industry.

By C. SIMMONS, O.B.E., B.Sc., F.I.C., F.C.S., *late Superintending Analyst in the Government Laboratory, London.*

## Aluminium.

*Its Manufacture, Manipulation, and Marketing.*

By GEORGE MORTIMER, M.Inst.Met.

## Anthracite.

By A. LEONARD SUMMERS.

## Asbestos.

By A. LEONARD SUMMERS.

## Bookbinding Craft and Industry.

By T. HARRISON.

## Boot and Shoe Industry, The.

By J. S. HARDING, *Head of the Boot Department of the Leeds Central Technical School.*

## Bread and Bread Baking.

By J. STEWART.

## Brushmaker, The.

By WM. KIDDIER.

## Butter and Cheese.

By C. W. WALKER TISDALE, F.C.S.; and JEAN JONES, B.D.F.D., N.D.D., *Deputy-Manager of the Wensleydale Pure Milk Society, Ltd.*

## Button Industry, The.

By W. UNITE JONES.

## Carpets.

By REGINALD S. BRINTON.

## Clays and Clay Products.

By ALFRED B. SEARLE, *Author of "The Ceramic Industries Pocket Book," etc., etc.*

## Clocks and Watches.

By G. L. OVERTON.

## Common Commodities and Industries—contd.

### **Clothing Industry, The.**

By B. W. POOLE, M.U.K.A., *Head of the Clothing Trades Dept., Leeds Central Technical School.*

### **Cloths and the Cloth Trade.**

By J. A. HUNTER.

### **Coal.**

**Its Origin, Method of Working, and Preparation for the Market.**

By FRANCIS H. WILSON, M.Inst.M.E.

### **Coal Tar.**

By A. R. WARNES, F.C.S., A.I.Mech.E., *Lecturer on Coal Tar Distillation at Hull Technical College.*

### **Cocoa and Chocolate Industry, The.**

By A. W. KNAPP, B.Sc., F.I.C.

### **Coffee. From Grower to Consumer.**

By B. B. KEABLE, *of Messrs. Joseph Travers & Sons.*

### **Cold Storage and Ice Making.**

By B. H. SPRINGETT, *Editor of "Ice and Cold Storage."*

### **Concrete and Reinforced Concrete.**

By W. NOBLE TWELVETREES, M.I.Mech.E., *Author of "Reinforced Concrete," etc.*

### **Copper.**

**From the Ore to the Metal.**

By H. K. PICARD, M.I.M.M., *Assoc. Royal School of Mines.*

### **Cordage and Cordage Hemp and Fibres.**

By T. WOODHOUSE and P. KILGOUR, *both of Dundee Technical College.*

### **Corn Trade, The British.**

By A. BARKER.

### **Cotton. From the Raw Material to the Finished Product.**

By R. J. PEAKE.

### **Cotton Spinning.**

By A. S. WADE.

### **Cycle Industry, The.**

By W. GREW.

### **Drugs in Commerce.**

By J. HUMPHREY, Ph.C., F.J.I.

### **Dyes.**

By A. J. HALL, B.Sc., F.I.C., F.C.S., *Technical Chemist.*

## Common Commodities and Industries—contd.

### **Electric Lamp Industry, The.**

By G. ARNCLIFFE PERCIVAL.

### **Electricity.**

By R. E. NEALE, B.Sc. (Hons.), A.M.I.E.E., A.C.G.I.

### **Engraving.**

By T. W. LASCELLES.

### **Explosives, Modern.**

By S. I. LEVY, B.A., B.Sc., F.I.C., *late of the Factories Branch Department of Explosives Supply.*

### **Film Industry, The.**

By DAVIDSON BOUGHEY.

### **Fishing Industry, The.**

By W. E. GIBBS, D.Sc.

### **Furniture.**

By H. E. BINSTEAD, *Editor of "The Furniture Record."*

### **Furs and the Fur Trade.**

By JOHN C. SACHS.

### **Gas and Gas Making.**

By W. H. Y. WEBBER, C.E., *of the Gas Light and Coke Company.*

### **Glass and Glass Making.**

By P. MARSON, *Consultant upon Refractory Materials, etc. ; Honours and Medallist in Glass Manufacture.*

### **Gloves and the Glove Trade.**

By B. E. ELLIS.

### **Gold.**

By BENJAMIN WHITE.

### **Gums and Resins. Their Occurrence, Properties, and Uses.**

By ERNEST J. PARRY, B.Sc., F.I.C., F.C.S.

### **Incandescent Lighting.**

By S. I. LEVY, B.A., B.Sc., F.I.C.

### **Ink.**

By C. AINSWORTH MITCHELL, M.A., F.I.C.

### **Internal Combustion Engines.**

By J. OKILL, M.I.A.E., *Author of "Gas and Oil Engine Operation."*

### **Iron and Steel. Their Production and Manufacture.**

By C. HOOD, *of the well-known firm of Messrs. Bell Bros., Ltd.*

### **Ironfounding.**

By B. WHITELEY.

## Common Commodities and Industries—contd.

### **Jute Industry, The.**

By T. WOODHOUSE and P. KILGOUR, *both of Dundee Technical College.*

### **Knitted Fabrics.**

By JOHN CHAMBERLAIN, *Head of the Textile Department, Leicester Municipal Technical Schools*; and JAMES H. QUILTER.

### **Lead, Including Lead Pigments.**

By J. A. SMYTHE, Ph.D., D.Sc., *Reader in Chemistry, Armstrong College.*

### **Leather. From the Raw Material to the Finished Product.**

By K. J. ADCOCK.

### **Linen. From the Field to the Finished Product.**

By ALFRED S. MOORE.

### **Locks and Lock Making.**

By F. J. BUTTER.

### **Match Industry, The.**

By W. HEPWORTH DIXON.

### **Meat Industry, The.**

By WALTER WOOD.

### **Motor Boats.**

By MAJOR F. STRICKLAND, M.I.E.E., M.I.M.E.

### **Motor Industry, The.**

By HORACE WYATT, B.A., *Hon. Sec. of the Imperial Motor Transport Council.*

### **Nickel.**

By F. B. HOWARD WHITE, B.A.

### **Oil Power.**

By SIDNEY H. NORTH, A.Inst.P.T.

### **Oils. Animal, Vegetable, Essential, and Mineral.**

By C. AINSWORTH MITCHELL, M.A., F.I.C.

### **Paints and Varnishes.**

By A. S. JENNINGS, F.I.B.D., *Editor of "The Decorator," Examiner in Painters' and Decorators' Work, City and Guilds of London Institute.*

### **Paper. Its History, Sources, and Production.**

By HARRY A. MADDUX, *Silver Medallist, Papermaking, 1909.*

### **Patent, Smokeless, and Semi-Smokeless Fuels.**

By J. A. GREENE, A.M.Inst.P.T.; and F. MOLLWO PERKIN, C.B.E., Ph.D., F.I.C.

### **Perfumery, The Raw Materials of.**

By E. J. PARRY, B.Sc., F.I.C., F.C.S.

## Common Commodities and Industries—contd.

### **Petroleum.**

By A. LIDGETT, *Editor of the "Petroleum Times."*

### **Photography.**

By WILLIAM GAMBLE, F.R.P.S., *Author of "Music Engraving and Printing."*

### **Platinum Metals, The.**

By ERNEST A. SMITH, A.R.S.M., M.Inst.M.M.

### **Player Piano, The.**

By D. MILLER WILSON.

### **Pottery.**

By C. J. NOKE and H. J. PLANT.

### **Rice.**

By C. E. DOUGLAS, M.I.Mech.E.

### **Rubber. Production and Utilization of the Raw Product.**

By C. BEADLE ; and H. P. STEVENS, M.A., Ph.D., F.I.C.

### **Salt.**

By A. F. CALVERT, F.C.S., *Author of "Salt in Cheshire."*

### **Shipbuilding and the Shipbuilding Industry.**

By J. MITCHELL, M.I.N.A.

### **Silk. Its Production and Manufacture.**

By LUTHER HOOPER, *Weaver, Designer, and Manufacturer.*

### **Silver.**

By BENJAMIN WHITE, *Fellow of the Royal Statistical and Royal Economic Societies.*

### **Soap. Its Composition, Manufacture, and Properties.**

By WILLIAM A. SIMMONS, B.Sc. (Lond.), F.C.S., *Lecturer on Soap Manufacture at the Battersea Polytechnic.*

### **Sponges.**

By E. J. J. CRESSWELL.

### **Starch and Starch Products.**

By H. A. AUDEN, M.Sc., D.Sc., F.C.S.

### **Stones and Quarries.**

By J. ALLEN HOWE, O.B.E., B.Sc., M.Inst.Min. and Met., *Fellow of the Geological Society of London.*

### **Straw Hats. Their History and Manufacture.**

By H. INWARDS, *Hat Manufacturer.*

### **Sugar. Cane and Beet.**

By GEO. MARTINEAU, C.B.

## Common Commodities and Industries—contd

### **Sulphur and Allied Products.**

By HAROLD A. AUDEN, M.Sc., D.Sc., F.C.S.

### **Talking Machines.**

By OGILVIE MITCHELL.

### **Tea. From Grower to Consumer.**

By A. IBBETSON, of Messrs. Joseph Travers & Sons.

### **Telegraphy, Telephony, and Wireless.**

By JOSEPH POOLE, A.M.I.E.E., *Author of "The Practical Telephone Handbook."*

### **Textile Bleaching.**

By ALEC B. STEVEN, B.Sc. (Lond.), F.I.C., *Lecturer on Bleaching, Dyeing, etc., at the Royal Technical College, Glasgow.*

### **Timber. From the Forest to Its Use in Commerce.**

By W. BULLOCK.

### **Tin and the Tin Industry.**

By A. H. MUNDEY.

### **Tobacco. From Grower to Smoker.**

By A. E. TANNER, *Chemical Officer in the Customs and Excise Department.*

### **Velvet and the Corduroy Industry.**

By J. HERBERT COOKE.

### **Wall Paper.**

By G. WHITELEY WARD, *Author of "Art and the Wall Paper," etc.*

### **Weaving.**

By W. P. CRANKSHAW.

### **Wheat and Its Products.**

By ANDREW MILLAR.

### **Wine and the Wine Trade.**

By ANDRÉ L. SIMON.

### **Wool. From the Raw Material to the Finished Product.**

By J. A. HUNTER.

### **Worsted Industry, The.**

By J. DUMVILLE and S. KERSHAW.

### **Zinc and Its Alloys.**

By T. E. LONES, M.A., LL.D., B.Sc.

Each book crown 8vo, cloth. Price 3s. net.

## FOREIGN LANGUAGES

### FRENCH

	PRICE
<b>Progressive French Grammar.</b> By DR. F. A. HEDGCOCK, M.A., D.ès.L. . . . . Net	5/6
<b>Commercial French Grammar.</b> By F. W. M. DRAPER, M.A., B.ès.L. . . . . Net	2/6
<b>French-English and English-French Commercial Dictionary.</b> By F. W. SMITH . . . . . Net	7/6
<b>Manual of French Commercial Correspondence.</b> By G. W. MACDONALD . . . . . Net	5/-
<b>Correct French Speech.</b> By B. DUMVILLE, M.A., F.C.P. . . . .	1/6

### GERMAN

<b>A New German Grammar.</b> By J. KEEGAN, M.A. . . . . Net	6/-
<b>Commercial German Grammar.</b> By J. BITHELL, M.A. . . . . Net	3/6
<b>German-English and English-German Commercial Dictionary.</b> By J. BITHELL, M.A. . . . . Net	10/6
<b>Commercial Correspondence in German.</b> Net	3/6

### SPANISH

<b>Spanish Commercial Grammar.</b> By C. A. TOLEDANO . . . . . Net	4/6
<b>Spanish-English and English-Spanish Commercial Dictionary.</b> By G. R. MACDONALD . . . . . Net	12/6
<b>Manual of Spanish Commercial Correspondence.</b> By G. R. MACDONALD . . . . . Net	4/6

### ITALIAN

<b>Italian Commercial Grammar.</b> By LUIGI RICCI . . . . . Net	4/-
<b>Mercantile Correspondence, English-Italian.</b> Net	5/-

## PORTUGUESE

	PRICE
Practical Portuguese Grammar.	Net 7/6
Mercantile Correspondence, English-Portuguese.	Net 3/6

## PITMAN'S SHORTHAND

For Complete List of Textbooks, Phrase Books, Dictation Books, Reading Books, etc., see Pitman's "SHORTHAND AND TYPEWRITING CATALOGUE."

Pitman's Shorthand Instructor.	4/6
Pitman's Shorthand Commercial Course.	4/6
Pitman's Shorthand Rapid Course.	4/6
Shorter Course in Pitman's Shorthand.	1/-
English and Shorthand Dictionary.	10/-
Shorthand Clerk's Guide.	
By V. E. COLLINGE, A.C.I.S. . . . .	2/6
Progressive Dictator.	2/6
Phonographic Phrase Book.	Paper 1/6, Cloth 2/-

## TYPEWRITING

Pitman's Commercial Typewriting.	
By W. and E. WALMSLEY . . . . .	5 -
Pitman's Typewriter Manual.	5/-
Business Typewriting.	
By F. HEELIS . . . . .	2/-
Practical Course in Touch Typewriting.	
By C. E. SMITH . . . . .	2/-
Dictionary of Typewriting.	
By H. ETHERIDGE . . . . .	Net 7/6
Mechanical Devices of the Typewriter.	
By R. T. NICHOLSON, M.A. . . . .	Net 6/-
Work and Management of a Copying Office.	
The	
By G. C. MENZIES . . . . .	Net 10/6

*Complete List post free on application.*

---

Sir Isaac Pitman & Sons, Ltd., Parker St., Kingsway, London, W.C.2



# CAREERS!!!

---

---

*Handy Guides which tell you all about the many occupations from which you must choose YOURS*

---

---

## **AUTHORSHIP AND JOURNALISM**

By ALBERT E. BULL.

Describes the best and most successful methods of earning a living with the pen.

## **HOW TO BECOME AN AUCTIONEER AND ESTATE AGENT**

By W. F. NOKES, F.A.T.

This book sets out the various stages of progress from the status of aspirant to that of fully-qualified practitioner. Valuable advice is given on study for examinations, and specimen examination papers are included.

## **HOW TO BECOME A PRIVATE SECRETARY**

By J. E. McLACHLAN, F.I.P.S. (Hons.).

This book is full of hints and suggestions, showing how to equip oneself for an appointment.

## **HOW TO BECOME A COMPANY SECRETARY**

By E. J. HAMMOND, A.C.I.S.

All desiring eventually to become company secretaries will find full particulars as to the examinations to be passed in order to obtain a professional diploma.

## **HOW TO BECOME A QUALIFIED ACCOUNTANT**

By R. A. WITTY, F.S.A.A.

Giving full information and guidance as to accountancy examinations, together with specimen examination papers.

## **HOW TO SUCCEED IN A BANK**

A Guide to Bank Employees. By F. E. STEELE.

Gives advice to members of a bank's staff, on securing the qualifications necessary for promotion.

## **HOW TO ENTER THE MERCANTILE MARINE**

By R. A. FLETCHER.

Describing the life and prospects of all classes, from deck hands to officers; and giving information as to Board of Trade examinations, training ships and institutions, tests to be passed, etc.

## **THE GAME OF COMMERCE**

By HERBERT KENDRICK.

A study of commercial conditions and guide to careers in commerce.

---

**EACH 3/6 NET**

**OF ALL BOOKSELLERS**

---

SIR ISAAC PITMAN & SONS, LTD., PARKER ST., KINGSWAY, LONDON, W.C.2

---

---

READ

# PITMAN'S JOURNAL

of Commercial Education

THE only weekly paper entirely devoted to the needs of teachers and students of Commercial Subjects, including—

OFFICE ROUTINE  
COMMERCIAL HISTORY  
COMMERCIAL GEOGRAPHY  
PITMAN'S SHORTHAND  
TYPEWRITING  
COMMERCIAL ARITHMETIC  
ENGLISH GRAMMAR & COMPOSITION  
BOOK-KEEPING AND ACCOUNTANCY  
COMMERCIAL FRENCH  
COMMERCIAL SPANISH

COMMERCIAL GERMAN  
BUSINESS ECONOMICS  
INSURANCE  
BANKING AND CURRENCY  
SHIPPING  
SECRETARIAL PRACTICE  
COMMERCIAL LAW  
CIVIL SERVICE  
ADVERTISING AND SALESMANSHIP  
MIND TRAINING

48 pages (demy 4to), with eight pages of specially engraved shorthand

WEEKLY 2d. WEEKLY

Order from a Newsagent or Bookstall

---

*Subscription Terms post free from the Publishers*

Sir Isaac Pitman & Sons, Ltd., Parker Street, Kingsway, W.C.2

---

---





U. C. BERKELEY LIBRARIES



C055291252

TS 1665  
H6  
1919

