

# LIPPINCOTT'S FARM MANUALS



## PRODUCTIVE SOILS

BY

W. W. WEIR, M.S.

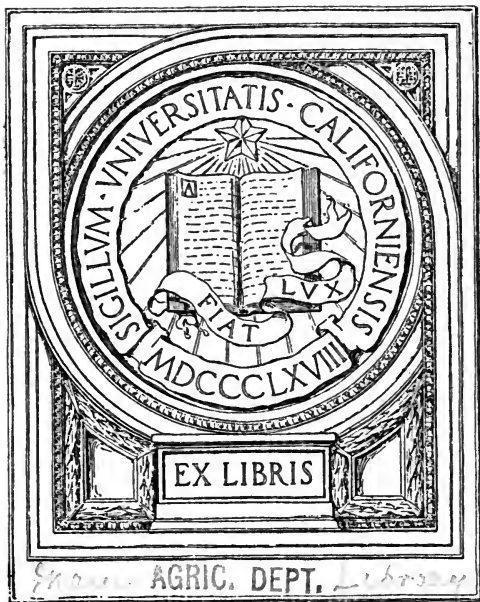

AGRIC. DEPT. Library

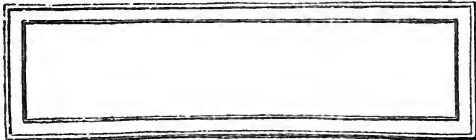

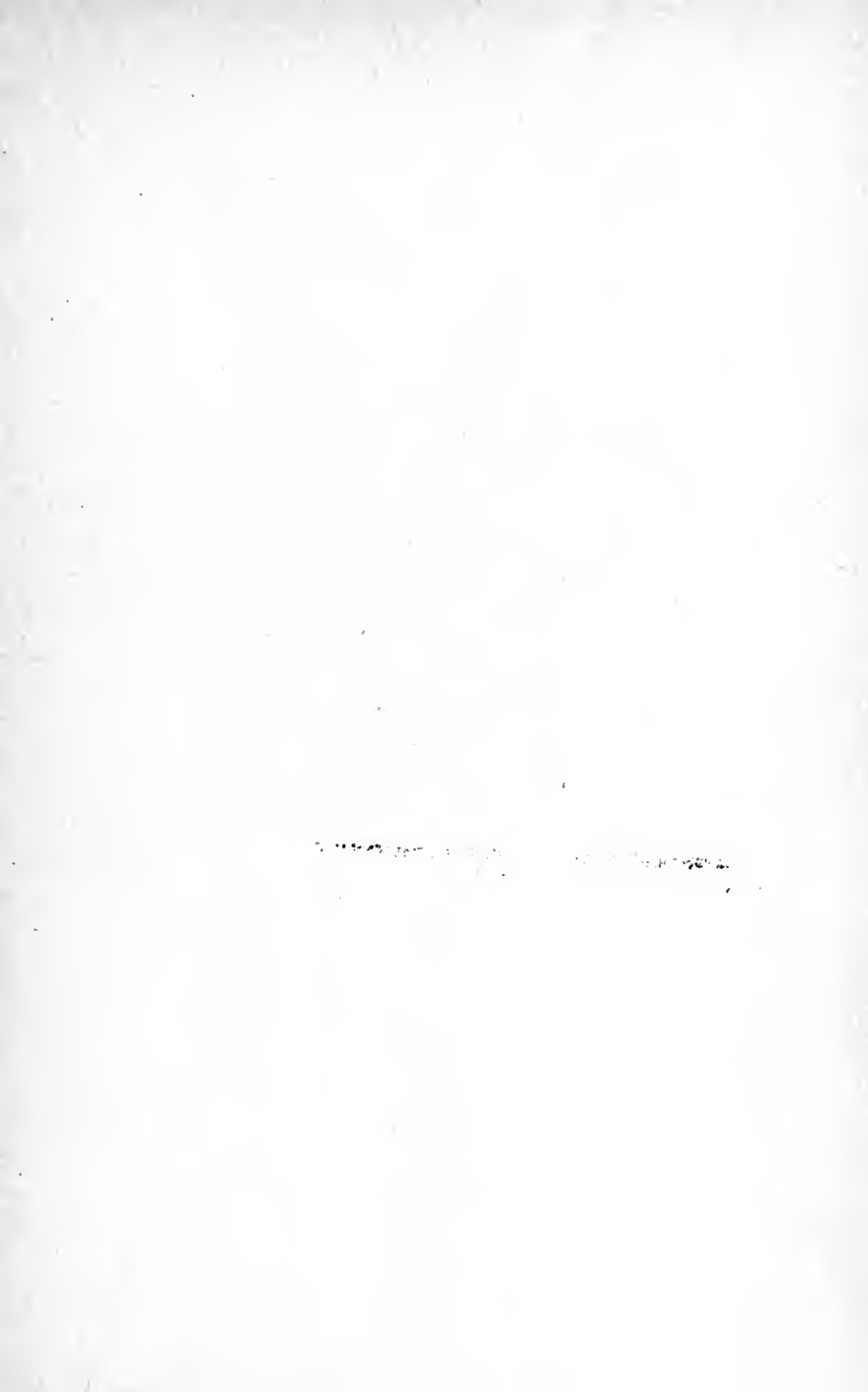

Digitized by the Internet Archive  
in 2007 with funding from  
Microsoft Corporation

"The first farmer was the first man, and all historic nobility rests on possession and use of land."

—EMERSON.

# LIPPINCOTT'S FARM MANUALS

EDITED BY  
KARY C. DAVIS, PH.D.

PROFESSOR OF AGRICULTURE, KNAPP SCHOOL OF COUNTRY LIFE, GEORGE PEABODY  
COLLEGE FOR TEACHERS, NASHVILLE, TENNESSEE; AUTHOR OF  
PRODUCTIVE FARMING, ETC.

---

## PRODUCTIVE SOILS

By WILBERT WALTER WEIR, M.S.

FORMERLY ASSISTANT PROFESSOR OF SOILS, FIELD MAN, WISCONSIN STATE SOILS  
LABORATORY AND SOIL EXTENSION SERVICE, COLLEGE OF AGRICULTURE,  
UNIVERSITY OF WISCONSIN

# LIPPINCOTT'S FARM MANUALS

Edited by K. C. DAVIS, Ph.D.

KNAPP SCHOOL OF COUNTRY LIFE, NASHVILLE, TENN.

---

- PRODUCTIVE SWINE HUSBANDRY 1915  
By GEORGE E. DAY, B.S.A.
- PRODUCTIVE POULTRY HUSBANDRY 1919  
By HARRY R. LEWIS, B.S.
- PRODUCTIVE HORSE HUSBANDRY 1920  
By CARL W. GAY, D.V.M., B.S.A.
- PRODUCTIVE ORCHARDING 1917  
By FRED C. SEARS, M.S.
- PRODUCTIVE VEGETABLE GROWING 1918  
By JOHN W. LLOYD, M.S.A.
- PRODUCTIVE FEEDING OF FARM ANIMALS 1916  
By F. W. WOLL, Ph.D.
- COMMON DISEASES OF FARM ANIMALS 1919  
By R. A. CRAIG, D.V.M.
- PRODUCTIVE FARM CROPS 1918  
By E. G. MONTGOMERY, M.A.
- PRODUCTIVE BEE KEEPING 1918  
By FRANK C. PELLETT
- PRODUCTIVE DAIRYING 1919  
By R. M. WASHBURN, M.S.A.
- INJURIOUS INSECTS AND USEFUL BIRDS 1918  
By F. L. WASHBURN, M.A.
- PRODUCTIVE SHEEP HUSBANDRY 1918  
By WALTER C. COFFEY, M.S.
- LIPPINCOTT'S COLLEGE TEXTS**
- SOIL PHYSICS AND MANAGEMENT 1919  
By J. G. MOSIER, B.S., A. F. GUSTAFSON, M.S.
- FARM LIFE TEXT SERIES**
- APPLIED ECONOMIC BOTANY 1919  
By MELVILLE T. COOK, Ph.D.
- PRODUCTIVE PLANT HUSBANDRY 1918  
By KARY C. DAVIS
- HORTICULTURE FOR HIGH SCHOOLS 1919  
By KARY C. DAVIS
- LABORATORY MANUALS AND NOTEBOOKS**  
ON THE FOLLOWING SUBJECTS
- SOILS, By J. F. EASTMAN and K. C. DAVIS 1915
- POULTRY, By H. R. LEWIS 1918
- DAIRYING, By E. L. ANTHONY 1917
- FEEDING, By F. W. WOLL 1917
- FARM CROPS, By F. W. LATHROP 1920

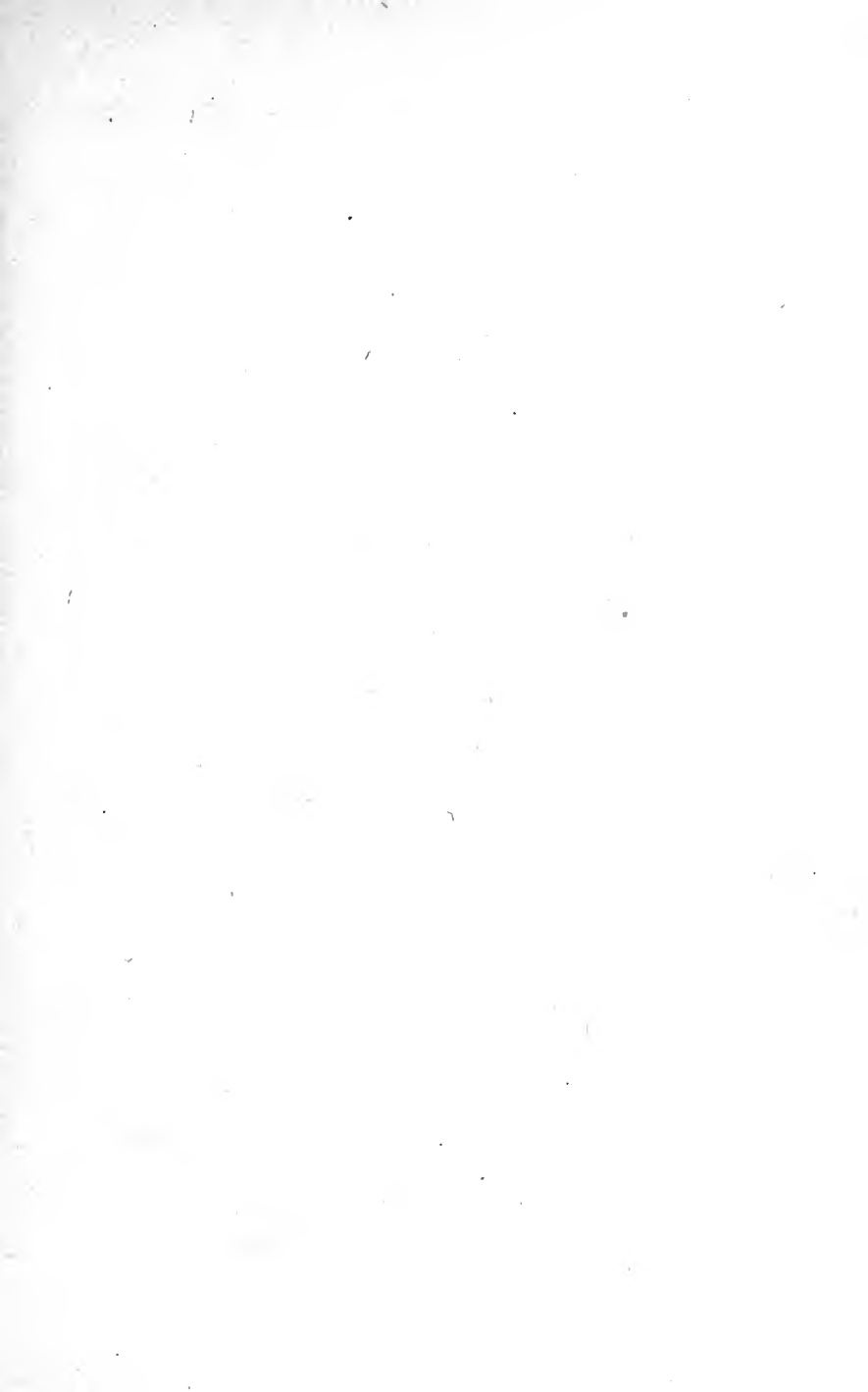



Why risk with men your hard-won gold?  
Buy grain and sow; your Brother Dust  
Will pay you back a hundredfold—  
The earth commits no breach of trust.

—DAVID GRAYSON.



# LIPPINCOTT'S FARM MANUALS

EDITED BY K. C. DAVIS, PH.D.

---

## PRODUCTIVE SOILS

THE FUNDAMENTALS OF SUCCESSFUL SOIL  
MANAGEMENT AND PROFITABLE CROP  
PRODUCTION

BY

WILBERT WALTER WEIR, M.S.

FORMERLY ASSISTANT PROFESSOR OF SOILS, FIELD MAN, WISCONSIN STATE SOILS  
LABORATORY AND SOIL EXTENSION SERVICE, COLLEGE OF AGRICULTURE,  
UNIVERSITY OF WISCONSIN

235 ILLUSTRATIONS IN THE TEXT

"If vain our toil,  
We ought to blame the culture, not the soil."  
POPE—*Essay on Man*



PHILADELPHIA & LONDON  
J. B. LIPPINCOTT COMPANY

COPYRIGHT, 1920, BY J. B. LIPPINCOTT COMPANY

MAIN LIBRARY AGRICULTURE DEPT

TO THE  
LIBRARY OF THE  
DEPARTMENT OF AGRICULTURE

*Electrotyped and Printed by J. B. Lippincott Company  
At the Washington Square Press, Philadelphia, U. S. A.*

DEDICATED  
TO THE INTERESTS OF BETTER FARMING

"A SOWER WENT OUT TO SOW HIS SEED; AND AS HE SOWED, SOME FELL BY THE WAYSIDE; AND IT WAS TRODDEN DOWN, AND THE FOWLS OF THE AIR DEVOURED IT. AND SOME FELL UPON A ROCK; AND AS SOON AS IT WAS SPRUNG UP, IT WITHERED AWAY, BECAUSE IT LACKED MOISTURE. AND SOME FELL AMONG THORNS; AND THE THORNS SPRANG UP WITH IT, AND CHOKED IT. AND OTHER FELL ON GOOD GROUND, AND SPRANG UP, AND BARE FRUIT AN HUNDREDFOLD."

433002



## PREFACE

THIS book is designed primarily to meet a growing demand for definite, practical and complete information concerning soils and profitable crop production. This, therefore, is a book of fundamentals, and hence applicable to a wide range of country. The basic facts concerning soils, and the fundamental principles of successful soil management are essentially the same everywhere, but the method of application must necessarily vary because of different climatic conditions.

This text represents an extensive experience on the part of the author—from practical farming before and after college graduation to university teaching and Extension Service. It is hoped that the facts and principles herein presented will lead the practical farmer and the student into a broad field of interesting and profitable knowledge.

To one who is familiar with the crumbling of the soil as it moves over the moldboard, these chapters will not be entirely new and strange, but will present things both new and old. It is the hope that the new and the old are presented in such a way as to eliminate the difficulty too often experienced by searchers after the fundamentals—namely, the failure to place the facts and principles in their true relation to successful farm practices—a difficulty which has been the result of a lack of proper organization and correlation of the subject matter.

In his teaching of many hundreds of farm boys as well as practical farmers, the author has had the opportunity to test out various methods of instruction and arrangement and correlation of the subject matter. Actual results have been the only guide in determining the best plan. Even after this course of study was fully completed it was thoroughly tried out on several classes before it was put into publication. The plan of the book may readily be seen by studying the Contents.

Special effort has been made to present the subject in as simple a form as possible while making it complete and authoritatively correct.

It is impossible to mention the many original papers, research data and other agricultural literature consulted.

This course of study in the complete edition is designed to give it wide adaptation, to wit:

(a) It may serve as a farmers' ready reference, or as a practical guide in successful soil management.

(b) In college short courses, and normals, the whole course as it is planned may be given. The object of each student should be to master the fundamentals.

(c) In college long courses, this text in the hand of the first- or second-year student may supply him with the fundamentals, leaving the lecture hour free to the instructor for elaboration, for application of facts and principles to local conditions, and for the presentation and discussion of experimental and research data.

The subject of Soil Management and Crop Production is truly large enough and of sufficient importance to be given a place in every agricultural curriculum. This subject should precede or may be given at the same time as the allied subject, Farm Crops. The latter subject could then be made a study, not so much of soils in relation to growing the crops, but rather of crop characteristics, crop importance, types, varieties, judging of grains, seed production, special cultural methods, harvesting, and care of crops and grains.

At the close of each chapter suggestions are offered for demonstrations, laboratory exercises, and for home experiments and projects. Many questions and practical problems are also given.

The author wishes to express his appreciation to Prof. E. Truog of the Department of Soils, and to Prof. J. A. James of the Department of Agricultural Education, University of Wisconsin, for careful reading and approval of the manuscript; to Prof. E. R. Jones, University of Wisconsin, for verifying the chapters on water relations and drainage; to Prof. C. F. Marbut, in charge of soil survey, Bureau of Soils, United States Department of Agriculture, for valuable suggestions concerning soil types and for approval of that part of Chapter II relating to that subject.

W. W. WEIR.

MADISON, WIS.  
January, 1920

## ACKNOWLEDGMENTS OF ILLUSTRATIONS

Yerkes Observatory—Fig. 1. M. C. Ford, Bowling Green, Ky.—Figs. 4, 34 and 199. The Macmillan Company—Figs. 13 and 43. L. W. Brown, Photographer, U. W.—Fig. 30 and frontispiece. American Chemical Company, Boston—Figs. 32, 142 and 169. Janesville Machine Company, Janesville, Wis.—Figs. 66, 68, 69, 71, 74, 85, 87, 92, 106, 107, 112, 143, 210 and 213. Deere and Company, Moline, Ill.—Figs. 73 and 88. Moline Plow Company, Moline, Ill.—Fig. 160. D. S. Bullock, U. W.—Fig. 144. Allis-Chalmers Mfg. Co., Milwaukee—Fig. 155. Rockfield Products Company, Milwaukee—Fig. 154. Jeffrey Mfg. Company, Columbus, Ohio—Fig. 157. J. S. Donald, Mt. Horeb, Wis.—Fig. 159. Mark W. Potter, Belhaven, N. C.—Figs. 195, 196 and 204. Mosier and Gustafson, authors of *Soil Physics and Management*—Figs. 18, 64, 67, 80, 93, 98. John W. Lloyd, author *Productive Vegetable Gardening*—Fig. 95. Kary C. Davis, author *Productive Plant Husbandry*—Fig. 93. U. S. Dept. of Agriculture—Figs. 170 to 187, inclusive.





# CONTENTS

## SOILS, THEIR ORIGIN AND CLASSIFICATION

CHAPTER	PAGE
INTRODUCTION .....	1
I. THE SOIL AND ITS ORIGIN .....	5
1. Soil Defined. 2. Soil is Forming from Rock all the Time. 3. The Weathering Agents: (a) Heat and cold, (b) frost, (c) wind, (d) ice, (e) water, (f) gases; aided by other forces of nature and by plants and animals. 4. Soil Formation is a Complex and Slow Process. 5. Most Soils are Carried Away or Moved After They Form. 6. Soil of Many Kinds.	
II. SOIL COMPOSITION, CLASSES AND TYPES .....	11
1. Common Meanings of Soil and Subsoil. 2. The Composition of Soil: (a) Mineral particles—sand, silt, clay—from rock. (b) Organic matter—remains of plants. 3. Soil a Complex Medium for Plant Growth: (a) Sand, silt, clay constitute the framework—and contains: (b) water (moisture); (c) soil organisms; (d) air; (e) salts in greater or less amounts. 4. Soil Classification: (a) On the basis of texture (grouped into classes): sand, fine sand, sandy loam, fine sandy loam, loam, slit loam, clay loam and clay. (b) On the basis of mode of formation: residual, cumulose, alluvial, glacial, marine, lacustrine, loess and colluvial. (c) On the basis of types (grouped into series): Dunkirk sand, Genesee loam, Knox silt loam, Cecil loam, etc., as types.	
<b>SOILS FROM A CHEMICAL POINT OF VIEW</b>	
III. CHEMICAL COMPOSITION OF SOILS AND ITS RELATION TO PLANTS AND ANIMALS .....	29
1. Soil Materials are Composed of Elements. 2. Chemical Composition of Soils. 3. The Fertilizing Elements—Nitrogen, Phosphorus and Potassium. 4. The Supply of the Important Elements in Soils not Large. 5. Chemical Composition of Soils Influences Plant Growth. 6. Crops Require Ten Elements—C, H, O, P, K, N, S, Ca, Fe, Mg. 7. Sources of Elements Plants Require: (a) The soil—nitrogen and mineral elements; (b) The soil water—oxygen and hydrogen; (c) The air—carbon and oxygen. 8. Ash of Animal Body is "Dust" of the Earth. 9. The Great Work of Plants and the Farmer's Business.	
IV. HOW ROCKS AND CLIMATE AFFECT SOILS .....	39
1. Rocks of Many Kinds, and They Undergo Changes. 2. A Rock is an Aggregate of Mineral Particles. 3. Rock Minerals the Sources of Mineral Plant-food Elements. 4. The Relation Between the Presence of Particles of Rock Minerals and the Richness of Soils. 5. Products of Rock Weathering: (a) Sand, silt, clay—breaking-up products; (b) True clay (kaolin). (c) Carbonate of lime. (d) Salts. 6. Different Soils from Different Rocks. 7. The Effect of Climate on Soils: (a) Soils in humid regions are leached. (b) Alkali soils—formed in dry regions. (c) Much organic	

CHAPTER	PAGE
matter in soils in cool, moist regions. (d) Deficient organic matter in soils in warm, moist regions. (e) Sour or acid soils found in humid regions.	
<b>SOIL AND PLANT RELATIONS</b>	
V. SOIL AN IMPORTANT FACTOR AFFECTING PLANT GROWTH . . . . .	47
1. Conditions Surrounding Plants Must be Favorable.	
2. Three Periods of Life History of Plant Passed in Contact with the Soil.	
3. The Germination Period: (a) Life in seed strives for existence. (b) Requirements—moisture, oxygen, favorable temperature and good tilth. (c) Tilth, good tilth, poor tilth defined. (d) Absorption of water by seeds influenced by contact between soil and seed, moisture, warmth and presence of salts.	
4. The Vegetative or Growing Period: (a) Period of greatest activity. (b) Conditions and requirements. (c) Full meaning and importance of good tilth, factors affecting development. (d) Availability of plant-food elements. (e) Special function of the plant-food elements.	
5. The Fruition Period.	
VI. CROPS AS FEEDERS ON THE PLANT-FOOD ELEMENTS IN THE SOIL	61
1. Soil Particles are not Plant Foods.	
2. Amount of Elements Removed by Harvested Crops.	
3. Some Facts Concerning the Feeding of Crops: (a) Most of phosphorus goes into grain, and potassium into stalk and straw. (b) All plants do not take the same amounts of the elements. (c) Alfalfa a "heavy feeder." (d) Timothy is not a "soil robber." (e) Some plants have strong feeding powers. (f) Barley requires a richer soil than oats. (g) Fertilizer needs best determined by tests.	
4. Amount of Plant-food Elements Removed by Fruit Crops.	
5. Supply of Nitrogen, Phosphorus and Potassium in Soils: (a) Supply varies in different soils. (b) Per cent vs. pounds of plant-food elements in soils. (c) Peat soils are usually deficient in the mineral elements (K and P). (d) Peat lands are sometimes deceptively advertised. (e) Subsoils contain plant-food elements.	
<b>CROP PRODUCTION</b>	
VII. CROP PRODUCTION AND SOIL FERTILITY . . . . .	75
1. Factors in Successful Crop Production: (a) Fertile soil, determined by moisture in soil, air in soil, good tilth, presence of helpful organisms, plant-food elements, absence of harmful agents. (b) Good seed: high test, adaptability, purity, disease resistant, high yielding, etc. (c) Favorable temperature. (d) Light: some crops require much light, some less; shading a factor in weed-killing; weeds may shade crops; one crop may deprive another of light. (e) Protection from injury: proper fencing, spraying, treating seed, drainage, etc.	
2. Soil Fertility (Defined).	
3. Factors which Determine Soil Fertility Same as Those Which Make a Fertile Soil.	
4. Soil Exhaustion: (a) Illustrated by draft upon the phosphorus supply. (b) Soil exhaustion usually the result of: the removal of organic matter; the removal of available plant-food elements; the removal of carbonate of lime; improper tillage.	
5. Most Soils can be Improved in Some Way.	

## FACTORS DETERMINING SOIL FERTILITY

- VIII. SOIL WATER AND ITS RELATION TO SOIL FERTILITY. . . . . 89
1. Why Plants Require Water. 2. Crops Require Much Water. 3. Water Requirements of Some Crops—Based on Dry Matter Produced. 4. Water Commonly Limits Crop Production. 5. Forms of Soil Water—Gravitational, Capillary and Hygroscopic. 6. Capillary Water of Most Importance: Held by soils in form of films around the soil particles, in organic matter, and within soil crumbs. 7. Movements of Water in Soils: Percolation, seepage, capillary rise of water. 8. Water-holding Capacity of Soils. 9. Moisture Conservation and Control—(a) Lessen surface run-off by aiding soils to trap water. (b) Increase water-holding capacity by adding organic matter. (c) Aid capillary rise of moisture by compacting the seed bed. (d) Lessen surface evaporation by developing a soil mulch. (e) Conserve moisture by killing weeds.
- IX. LAND DRAINAGE AND IRRIGATION. . . . . 109
1. Too Much Water is Harmful. 2. Benefits of Proper Drainage. 3. How Drainage is Accomplished: (a) Surface drainage. (b) Subsurface drainage. (c) Vertical drainage. (d) Combined methods. 4. Tile Drainage: (a) Drain tile and how they are laid. (b) Distance to lay lines of tile. (c) Systems of tile drainage—natural, gridiron, herring-bone and combination of systems. (d) Cost and benefits of tile drainage. 5. Drainage by Means of Pumps. 6. Irrigation Defined: (a) Objects of irrigation and how irrigation water is secured. (b) How irrigation water is applied—flooding, furrow irrigation, spray irrigation and sub-irrigation. (c) Irrigated farms require good management. (d) Many irrigated lands need drainage. (e) Profits in irrigation farming. (f) Irrigation an art of antiquity.
- X. TILTH AND TILLAGE. . . . . 135
1. Tilt and Tillage in General: (a) Factors determining development of good tith. (b) Tillage tools are many. (c) Objects and principles governing tillage. 2. Preparing the Seed Bed: (a) Plows and plowing. (b) Subsoiling, deep tilling and dynamiting soils. (c) Harrows and harrowing. (d) Rollers, plankers and clod crushers. 3. Seeding and Planting: (a) Good firm seed bed favors planting. (b) Drills vs. broadcast grain seeders. (c) When discing is better than plowing. (d) Listing. 4. Cultivation and Intertillage: (a) Why crops are cultivated. (b) Cultivators and their adaptability. (c) When and how to cultivate.
- XI. SOIL ORGANISMS IN RELATION TO SOIL FERTILITY. . . . . 171
1. Organisms of Decomposition: (a) No crops without decay. (b) Organisms cause decay of organic matter. (c) Decay of organic matter aids decay of mineral particles. (d) Some fertilizers would be valueless without decay. 2. Bacteria Which Cause Nitrification: (a) Importance of nitrification. (b) Catch and cover crops conserve nitrates. (c) Nitrification results in loss of organic matter. 3. Bacteria which Fix Atmospheric Nitrogen in Soils: (a) Two groups of nitrogen-fixing bacteria. (b) Amount of nitrogen gathered per acre. (c) How nodule bacteria work. (d) How the growing of legumes improves soils. (e) Soil inoculation and methods. (f) Conditions favoring soil bacteria.

XII. NITROGEN, PHOSPHORUS AND POTASSIUM IN RELATION TO SOIL FERTILITY.....	187
<p>1. Fertilization and the Theory of Fertilizers. 2. Green manuring: (a) Green manuring and its benefits. (b) Crops for green manuring—legumes best. (c) Plowing under the crop—when, how and for what crops. (d) Feeding vs. plowing under the crop. (e) Some hints on green manuring. 3. Commercial Fertilizers: (a) Four classes of commercial fertilizers. (b) Nitrogen fertilizers and their value. Legumes to solve nitrogen problem. (c) Phosphate or phosphorus fertilizers and their uses. (d) Potash or potassium fertilizers and their value. (e) Mixed fertilizers. (f) Concerning commercial fertilizers in general. (g) Soils and crops determine kind to use. (h) Home mixing of fertilizers. (i) How commercial fertilizers may be applied. (j) Lasting effect of fertilizers. 4. Manure as a Fertilizer: (a) Some facts about manure: (1) Fertilizing value about \$2.34 per ton. (2) Manures differ in fertilizing value. (3) Feeding affects value of manure. (4) Amount of manure produced by farm animals. (5) Liquid portion of manure valuable. (b) Some practical pointers on use and care of manure: (1) Manure has three-fold value. (2) Manure a quick fertilizer. (3) Stall manure better than open-yard manure. (4) Hints on storing manure. (5) Light applications better than heavy applications. (6) Plowing under vs. discing in manure. (7) Applying manure to clover fields. (8) Manure not a perfect fertilizer.</p>	
XIII. SOIL ACIDITY AND LIMING IN RELATION TO SOIL FERTILITY....	229
<p>1. Soil Acidity Explained. 2. Soil Acidity Lowers Soil Fertility (Productiveness). 3. The Meaning of Liming. 4. How Liming Improves Acid Soils: (a) Available calcium is added for clover and alfalfa. (b) Absence of acidity favors the helpful soil organisms. (c) Plant-food elements are rendered more available. (d) Greater returns are secured from fertilization. (e) Lime tends to improve tilth on heavy soils. (f) Helps to control malnutrition diseases of truck crops. (g) Weeds may be better controlled. 5. Crops Benefited by Liming When Grown on Acid Soils. 6. Crops Which Tolerate Acidity. 7. How Acid Soils May be Determined: (a) By the use of blue litmus paper; (b) by chemical tests; (c) by alfalfa and clover failures; (d) by the growth of certain plants. 8. Low Wet Lands not Necessarily Acid. 9. How Soils Become Acid—Extent of Acid Soils. 10. The Nature of Soil Acidity. 11. Kinds of Agricultural Lime. 12. Comparative Value of Agricultural Limes—the Best to Use. 13. Amount of Lime to Apply. 14. When, How and How Often to Apply Lime. 15. Deep Plowing Cannot be Substituted for Liming. 16. Soils Derived from Limestone May Become Acid. 17. Soil Fertility is Regulated Through Liming.</p>	
XIV. HARMFUL AGENTS IN SOILS AFFECTING FERTILITY.....	255
<p>1. Worms and Insects in Soils May Destroy Crops. 2. Diseases in Soils May Cause Crop Failures. 3. Too Much Water in Soils is Harmful. 4. Alkali Salts in Soils is Injurious. 5. The Toxin Theory of Infertility. 6. Other Harmful Agents.</p>	

**CROP PRODUCTION AFFECTED BY SYSTEMS OF CROPPING****XV. CROP ROTATION AND ITS RELATION TO SOIL FERTILITY..... 263**

1. Crop Rotation Defined. Kinds of Rotation. One-Crop System. 2. Why Crops Should be Grown in Rotation: (a) Primary object to increase production and help maintain it. (b) Specific benefits of rotation: (1) Helps to control insect pests. (2) Helps to control certain plant diseases. (3) Favors accumulating of soil organic matter. (4) Tillth and workability of soils may be improved. (5) Rotation helps to conserve fertilizing elements. (6) Aids in fertilization and liming. (7) Weeds may be better controlled. (c) Rotation helps to maintain and increase soil fertility. 3. Rotation Can Not Take the Place of Fertilizers. 4. Factors Determining a Good Rotation. (a) Proper combination of crops. (b) Proper order in growing the crops. 5. Crop Rotation Important in Soil Improvement. 6. Some Practical Rotations. 7. Rotations for Truck Farming and Vegetable Growing.

**APPLICATION OF PRINCIPLES TO MANAGEMENT OF SPECIAL SOILS****XVI. SOIL EROSION..... 283**

1. Soil Erosion a Serious Problem. 2. Injuries Resulting from Erosion. 3. Causes of Erosion. 4. Kinds of Erosion. 5. Prevention of Erosion. 6. Stopping Washing and Reclaiming Eroded Lands.

**XVII. THE MANAGEMENT OF MARSH LANDS ..... 293**

1. Kinds of Marsh and Swamp Soils. 2. Advantages in Farming Marsh Lands. 3. Problems in Peat and Muck Management, and Solutions. 4. Crops for Marsh Lands. Rotations. 5. Types of Farming for Marsh Lands.

**XVIII. SANDS AND THEIR MANAGEMENT..... 309**

1. Important Classes of Sandy Soils. 2. Advantages in Farming Sands. 3. Problems in Sand Management and How to Solve Them. 4. Crops for Sands. Crop Rotation. 5. Types of Farming.

**XIX. THE MANAGEMENT OF CLAYS AND DEPLETED SILT LOAMS..... 321**

1. Clay Management: (a) Character of clay soils and their advantages. (b) Important problems and their solutions. (c) Crops for heavy clays. (d) Rotations and types of farming. 2. Improvement of depleted silt loams: (a) Liming a common first consideration. (b) Importance of fertilizers and organic matter. (c) Proper rotation.

**PRINCIPLES OF SOIL FERTILITY APPLIED TO THE FARM AS A WHOLE****XX. FARM MANAGEMENT AND CROP ROTATION ..... 327**

1. Soil Problems are Important Farm-Management Problems. 2. Diversified Farming and Its Advantages: (a) It economizes in the use of labor. (b) A more dependable income is assured. (c) It permits of crop rotation. 3 Crop

	Rotation an Essential Factor in Successful Farm Management: (a) Aids in maintaining and increasing fertility. (b) Systematizes farm operations. (c) Aids in solving soil and crop problems. 4. Crop Rotation in Practical Farming. 5. Factors Which Determine Kinds of Rotations. 6. How to Plan Rotations: (a) When a farm is already stocked. (b) For a stock farm not yet stocked. (c) For a grain farm having soil problems. (d) For a truck farm having soil problems. 7. Rotations—Application and Illustrations. 8. Other Points on Crop Rotation.	
XXI. SYSTEMS OF FARMING AND THEIR RELATION TO SOIL FERTILITY		343
	1. Systems of Farming—Grain, Stock, Truck and Combination. 2. Grain Farming vs. Stock Farming: (a) Grain farming is important. (b) Grain farming has led to soil depletion, but revised. (c) Stock farming is popular. (d) Maintaining fertility by stock farming not probable. (e) Possible to maintain fertility by either grain or stock farming. (f) Combination of grain and stock farming popular. 3. An Account With the Plant-food Elements in Farming: (a) Nitrogen and phosphorus balance indicative of good farming. (b) Diagram showing sources of loss and gain of the plant-food elements in farming. (c) Rules for determining losses and gains. (d) The nitrogen-phosphorus balance sheet.	
<b>OTHER POINTS ON SOIL MANAGEMENT</b>		
XXII. HOW THE NEEDS OF SOILS MAY BE DETERMINED		355
	1. Chemical Analysis has Limitations. 2. Other Factors to be Considered First Before Chemical Analysis is Made of Soil. 3. Chemical Analyses and Their Value: Need of Lime, Tests for Nitrogen, Phosphorus and Potassium. 4. Pot Tests—Not Fully Reliable. 5. Field or Plot Tests Are Most Reliable: (a) Scientific tests by Experiment Stations. (b) Practical tests by farmers. 6. Value of Farm Examinations.	
XXIII. PROFITABLE CROP PRODUCTION		369
	1. Large Crops not Necessarily the Most Profitable. 2. Profitable Crop Production Determines Successful Farming. 3. Profits Determine Fertilizer Practice. 4. Important to Determine the Point at Which Crop Production is Most Profitable. Value of Untreated Plot. 5. Proper Basis for Determining Most Profitable Fertilizer. 6. Proper Kind and Amount of Fertilizers Important: (a) Application of the law of the minimum. (b) Application of the law of diminishing returns. 7. Factors Favoring Greatest Profits Per Acre: (a) When soil is properly fertilized. (b) When high crop prices prevail.	
XXIV. FARMING IN REGIONS OF LIMITED RAINFALL		377
	1. Dry-farming of Much Importance. 2. Water Problem and Soils. 3. Farming Methods—Summary of Results. 4. Crops for Dry-land Farming. 5. Dry-farming Practices. 6. Stock in Dry-land Farming. 7. Good Farming is Essential to Successful Farming Everywhere.	
APPENDIX		383

# PRODUCTIVE SOILS

## INTRODUCTION

THE chief concern of the human race is its physical needs. Its greatest needs—food and clothing, depend entirely upon the soil which is intimately associated with life. Myriads of plants and animals have lived upon the earth for ages and ages because soil exists.

Every nation is deeply interested in the soil and its crops. Shall we grow more wheat to meet the demands of our increasing population, or shall we import it? Shall we meet the demand for more cotton, or shall it be grown elsewhere? Are our working people to have meat on their tables in the years to come, or will the price of meat be beyond their means? These questions can be answered only by the soil.

**Relative Decrease in Wheat and Corn.**—During the 30-year period between 1879 and 1909, the increase in corn production was 45.5 per cent, and in wheat production 48.7 per cent; while the increase in population for the same period was 83.4 per cent. The production of corn and wheat did not keep pace with the increase in population. During this period the exportation of wheat declined.

**Actual Decrease in Corn and Wheat.**—The Thirteenth United States Census (1910) showed an absolute decrease in corn and meat production since the Twelfth Census (1900), while the population increased over 20,000,000—and this in a comparatively new country! The extra effort put forth by the farmers and agricultural organizations to increase production during the World War resulted in marked increases in the production of corn, grain, meat and dairy products (Report of the Secretary of Agriculture, 1918).

The United States produces 71.5 per cent of the world's corn crop and consumes 70 per cent; it produces 18 per cent of the world's wheat crop and consumes 15 per cent; it produces 27 per cent of the world's oat crop and consumes 26 per cent; and it produces 6.5 per cent of the world's potato crop and consumes 7 per cent. Thus there is the possibility of only a small exportation of these food crops. If the productive power of this country is not increased, exportation of any food crop must necessarily cease,

and the problem of feeding our people will become the more serious. Shall it be importation of food or shall it be home production? It is to be noted that there is already a small importation of potatoes.

**Relatively Low Yields.**—The United States is far from being the leading nation in yields per acre, as is shown by the following 10-year averages:

*Average Yield Per Acre (Bushels)*

Crops	England	Germany	United States
Wheat.....	32.6	28.4	13.9
Oats.....	44.7	49.3	29.8
Rye.....	26.7	24.6	15.8
Potatoes.....	230.0	224.0	96.0

These facts place a responsibility upon every American farmer. The crop production problem is a national one. The farming of virgin soils is now practically a thing of the past, and soil depletion cannot long continue.

What is the reason for the higher crop yields in European farming? Theirs is an agriculture older than ours. Let us consider the answers of the agricultural leaders of some of the Old Countries in reply to the question as to why their average yields per acre of wheat and other cereal crops have almost doubled in the last 80 or 100 years.

From England: "The factors at work in the increase have been . . . better cultivation and tillage. . . . The great factor has been the introduction of fertilizers and purchased feeding stuffs."

From Germany: "In general I assume that of the 100 per cent increase in the yield can be attributed: To artificial fertilizers, 50 per cent; . . . better tillage of the soil, 25 per cent; to the use of better seed, 15 per cent; to the better crop rotation, 10 per cent."

From France: ". . . we submit in the following figures . . . the relative importance of the different factors (increase in production taken as 100): (Extensive Agriculture). Effect of fertilizers, 70 per cent; effect of preparation of the land, 15 to 20 per cent; effect of selection of seed and improved varieties, 5 to 10 per cent."<sup>1</sup>

It is to be observed that 85 to 90 per cent of the 100 per cent increase in their crop yields has been the result of better soil management. Here is a lesson from Europe for us.

**Our National Problem.**—Shall we wait yet awhile before considering seriously the better management of our soils? Have we

<sup>1</sup> European Practice and American Theory Concerning Soil Fertility. *Illinois Circular No. 142, 1910.*



not already enough acres of abandoned agricultural lands in this country? The United States does not stand first in yields per acre, but it does excel all other nations in rapidity of soil exhaustion.

Nationally and individually, the time to adopt methods to maintain productiveness and to improve our soils is while we are prosperous. This task challenges every tiller of the soil, every farm boy and girl, the dwellers in cities, every agricultural organization, and all other forces which strive for betterment through human endeavor. No greater force can man set into action than the power of the intellect—and this is accomplished through education. Then let it be education.

The general sentiment among thinking farmers is—"How little we know about soils and how much there is to know!" These farmers have not had the opportunities for agricultural training existing today. They cannot now go to school, hence instruction should be carried to them. This information, as well as that given to students in all practical or first courses, should not be technical and lop-sided, but simple, practical and well-balanced so as to enable our present-day farmers and those of the future to gain a happy living, and at the same time to conserve the great fundamental asset of our Country—the soil.

#### TO THE TEACHER

It may not be necessary, or time may not permit, to perform all the exercises indicated. Only those should be selected which will best supplement the class work. Frequently it becomes necessary to combine class work, demonstrations and laboratory exercises, or to make the laboratory exercises demonstrational. Local conditions should determine in a large degree the exercises to be selected. Those listed here may suggest others more suitable to local conditions.

Field trips should be carefully planned to include as many observations as possible. The leader, or teacher, should first go over the ground alone in order to map out the trip and determine what observations are to be made.

The materials needed for demonstrations and laboratory work are based on one demonstration or exercise.

The demonstrations which require time before the results may be shown should be started in time to be ready when needed. (Note demonstrations for Chapters V, VI, VII, VIII, IX, XI, XII.)

Students should keep laboratory note books when laboratory work is given. A definite order should be followed in writing up each exercise as follows:

- Exercise No. — (Number exercises in order performed.)
- Object of exercise.
- Procedure (state briefly how exercise was conducted).
- Results (make use of sketches and tabulated data).
- Conclusions (facts brought out or principles illustrated).
- Questions (write out questions with answers).

## CHAPTER I

### THE SOIL AND ITS ORIGIN

**What Soil Is.**—In its broad meaning, soil is that friable, upper stratum of the earth composed for the most part of mineral matter resulting from the breaking up and decay of rocks. It extends to solid rock—varying in depth from an inch or so to many hundreds



FIG. 1.—A spiral nebula. It is believed that the earth was at one time a revolving mass of gaseous material.

of feet. Mixed with this mineral matter,<sup>1</sup> especially at the surface, is more or less organic matter incorporated through the subsequent growth of vegetation.

**Soil Is Forming All the Time.**—The fact that soil is derived from rocks implies that it is one of the later products of creation. All soil, however, was not formed in some particular period in the early history of the earth—some of it was formed millions of years ago and some is being formed today.

---

<sup>1</sup> Generally speaking, mineral matter is any substance not formed by plants or animals. Organic matter is any substance formed by plants or animals.

**Rock Weathering the Soil-forming Process.**—The formation of soil is the result of the slow process of rock weathering, meaning the breaking up and decay of rocks brought about by the destructive action of the forces of nature. These forces include:

(a) **HEAT** and **COLD**—causing cracking and splitting of rocks through sudden temperature changes.

(b) **FROST**—causing splitting and cracking by freezing water.



FIG. 2.—Sugar Bowl Rock, Dells of the Wisconsin River. Water wears away and helps to disintegrate rocks.

(c) **WIND**—causing abrasion through the action of dust and sand particles carried by it.

(d) **ICE**—causing grinding as in glacial action.

(e) **WATER**—a wearing and dissolving agent, also producing chemical changes<sup>2</sup> (Figs. 2 and 3.)

(f) **GASES**— $\left\{ \begin{array}{l} \text{Oxygen,}^3 \text{ producing chemical changes.} \\ \text{Carbon dioxide, or carbonic acid gas, producing} \\ \text{chemical changes.} \end{array} \right.$

<sup>2</sup> Chemical changes are the decay processes in rock weathering.

<sup>3</sup> Oxygen is a gas composing 20.7 per cent of the air. Carbon dioxide is a heavy gas consisting of the elements carbon and oxygen ( $\text{CO}_2$ ).

**Other Forces of Nature.**—These weathering agencies are assisted in rock destruction by other forces of nature, such as volcanic eruptions, earthquakes, the force of gravity, etc., and to a greater or less degree by plants and animals. Plants in their growth frequently crack and split rocks because of root expansion, and hasten rock decay through chemical action caused by certain substances excreted from their roots. Man as a destructive creature has cut down forests and destroyed the natural soil covering of grass and shrubs. The washing away of the soil which follows very often ex-



FIG. 3.—The "Dutch Wedding," Monumental Park, Colorado. Sandstone rocks sculptured by the erosive action of water (in past ages) and wind. *New International Cyclopaedia.*

poses new rock surfaces to the weathering agencies (Fig. 4). Burrowing animals also expose fresh rock surfaces, or openings made by them facilitate the entrance of weathering agents to lower levels. Fungi, and even the tiny bacteria lend their aid. Even after plants and animals are dead they contribute further to rock decay, since in their decay acids are formed which hasten the changing of rock and rock particles into soil.

**Soil Formation not a Simple Process.**—It is evident that soil formation is not a simple process, but rather complex and slow. It began no doubt as soon as the once gaseous and molten earth passed



FIG. 4.—From rock into soil. The lower stratum of the soil has a composition approaching that of crumbled and decayed rock. Lower down the rock characteristics appear more plainly, and still farther down occurs the solid rock itself.

into a firm, stony sphere, and made more complicated because of the eternal forces which wrought such tremendous changes since the earth began—which forces brought into existence continents and oceans, lakes and rivers, mountains, hills and valleys, deserts and prairies.

**Weathering Continues Indefinitely.**—Weathering does not cease when it has reduced rocks to soil, but continues to act indefinitely upon the soil itself. If it were not so the best prairie soils would be incapable of supporting a single blade of grass. In this sense crops, vegetation and life are possible upon this earth largely because of decay.

**Soil from Rock May be Observed.**—Soil wherever found is underlaid by some kind of rock—it may be the rock from which the soil was formed or some foreign rock. Where soil is found underlaid by its parent rock there is no definite dividing line between the solid rock and the soil above it—the one grades into the other. The lower stratum of the soil has a composition approaching that of crumbled and decayed rock. Lower down the rock characteristics appear more plainly, and still farther down occurs the solid rock itself.

**Soils are Carried Away after They Form.**—All the soil we see was not formed from the rock that may be found under it. This is due to the fact that many soils are carried away after they are formed and deposited on other rocks. Water, ice and wind are and have always been the main soil transporting agents.

**Soil of Many Kinds.**—Because of the source of soil building materials, the nature of soil formation, the forces to which the earth has been and is being subjected, and because of the transporting and mixing action of water, wind and ice, all soil can not be the same, but must necessarily vary in composition, both physically and chemically. These variations give rise to many kinds and types of soil, and necessitate convenient classification. A knowledge of these soil variations, classes and types becomes of primary importance.

**Illustration Material for Lessons.**—Students should bring to class:

1. Specimens of rocks undergoing weathering.
2. Samples showing gradations of rock into soil.

**Field Studies.**—1. Observe if possible the weathering of native rock into soil, and note the action of the various weathering agents.

2. Observe the transportation and movement of soil.
3. Observe various kinds of soil—note location, etc.

## QUESTIONS

1. What is soil and when was it formed?
2. Name two classes of materials composing soil.
3. Distinguish between them.
4. What is meant by rock weathering?
5. Name some of the forces which break up and cause rocks to decay.
6. In what ways do plants and animals aid in the weathering of rocks?
7. Is soil formation a simple process? Explain.
8. When does weathering cease?
9. What is the importance of "soil weathering"?
10. Is it possible to observe the stages in the changing of rock into soil?
11. What are the facts to be observed?
12. In every case is soil formed from the rock found underlying it? Explain.
13. Why should there be many different kinds and types of soil?
14. What kinds have you seen?
15. For an outline summary of this chapter see table of contents.





**Silt particles** are soil grains medium in size between sand and clay. When moistened, silt has a velvety "feel," but not sticky like clay.

Sand, silt and clay as used here refer simply to size of individual soil grains and nothing more.

**Organic matter** in most soils occurs largely as a well-decomposed residue, black or dark in color and coating the soil grains. Frequently plant fiber of recent growth can be distinguished.

Humus may be defined as a black, waxy, complex substance

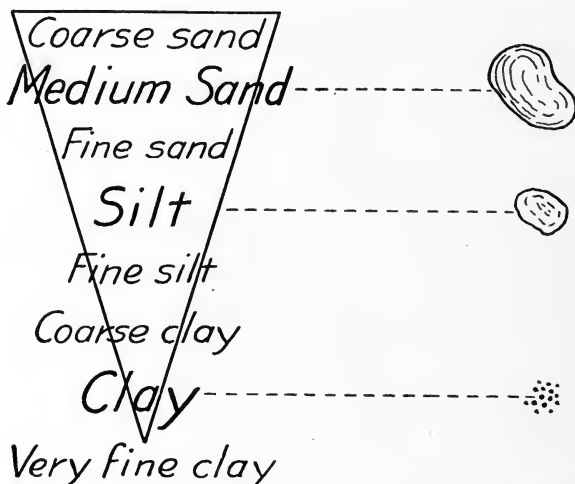

FIG. 5.—Diagram illustrating the sizes of soil grains. The coarsest particles grade into the finest.

of coating the soil grains, and which is derived from partial decay organic matter. All humus is organic matter, but all organic matter is not humus.

The term humus is sometimes used as a general term meaning organic matter. In these chapters we shall use the term "organic matter" since that is more readily understood.

**Soil is a Complex Medium.**—What we call soil is something more than a mere mixture of sand, silt, clay and organic matter. It is a composite, the framework of which is mineral matter. Aside from organic matter it contains:

(a) *Water* (moisture) which in reality is a dilute solution containing weak acids and small amounts of any soluble substance found in the soil.

(b) *Soil organisms*—bacteria, fungi and worms. These have

come to live in the soil by the millions because of the presence of organic matter which, because of the energy or food stored up in it, is the source of most of their sustenance and their energy. Some of these organisms are a detriment to soils, while others, because of fundamental changes they bring about, are of the greatest importance in crop production.

(c) *Air*—Soil as a medium for plant growth must contain air.

(d) *Salts* in greater or less amounts—in dry climates much.

#### SOIL CLASSIFICATION

Since the building materials of soils are largely mineral particles which remain more or less the same in size and amounts in any particular soil, we are afforded a basis whereby soils may be classified.



A

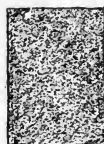

B

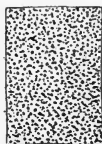

C

*Crummy structure    Compact structure    Sandy structure*

FIG. 6.—Diagrams illustrating soil structures.

**Soil Texture a Basis for Classification.**—The most convenient and general scheme for soil classification is based on the amounts of sand, silt and clay soils contain—or in other words, on the basis of “texture.”

**What Soil Texture Means.**—Soil texture may be defined as a quality denoting comparative coarseness or fineness of soils as is determined by the relative abundance of sand, silt and clay contained in them. For example, a soil having coarse sand predominating is a coarse textured soil, whereas one having much clay is regarded as fine textured.

**Meanings of Texture and Structure Compared.**—Texture should not be confused with soil “structure” which means the arrangement of the soil grains (Fig. 6), or which describes the relation of the soil particles to each other. It is important to remember that the soil components do not form a mere casual mixture in which every particle remains separate from every other particle. With the exception of sands, the soil components, because of the

cementing nature of much of the organic matter, group themselves into compound particles and granules, thus developing a "crummy" or "granular" structure. When a "heavy" soil does not crumble, but is a hard, compact mass instead, it may be said to have a "compact" structure. A sand may be described as having a "loose" or "sandy" structure.

**Soils Classified According to Texture.**—Eight principal soil classes based on texture are recognized. They are here given in an order ranging from the coarsest to the finest textured soils.

<i>Soil classes</i>	<i>How distinguished</i>
1. Medium sand.....	Composed of 80 to 100 per cent sand (much medium and coarse sand).
2. Fine sand.....	Composed mostly of fine sand.
3. Medium sandy loam.....	Having 50 to 80 per cent sand.
4. Fine sandy loam.....	Having 50 to 80 per cent fine sand.
5. Loam.....	Composed of 30 to 50 per cent sand and 50 to 70 per cent silt and clay.
6. Silt loam.....	Containing 50 per cent or more of silt.
7. Clay loam.....	Containing 20 to 50 per cent sand, 20 to 50 per cent silt, and 20 to 30 per cent clay.
8. Clay.....	Having 30 per cent or more clay.

A soil class is understood to mean all soil of the same texture. For example, soils consisting of about 50 per cent sand and about 50 per cent silt and clay belong to one and the same class regardless of where they may be found. By virtue of its texture this class of soil is named "loam."

A loam is to be defined as a class of soil composed of about half sand and the remaining half silt and clay (more silt than clay).

Again, a silt loam is to be defined as a class of soil, or a soil class, containing 50 per cent or more of silt.

Of these classes of soils, silt loams are most widely distributed, loams take second place, and fine sandy loams third.

In this classification no consideration is given organic matter. Soils containing much stone or gravel may be described as stony silt loam or gravelly loam, as the case may be. Gradations may also occur; such as, silty clay loam, loamy fine sand, etc.

**"Marsh" and "swamp" soils** are to be regarded as class names though they are not included in the classification based on texture.

Marsh is commonly interpreted to mean a wet level area covered with grasses. There are salt and fresh-water marshes.

Swamp is usually understood to mean low, wet areas of fresh water formation covered with tree growth. Tamarack swamp, cedar swamp, and cypress swamp are familiar expressions.

**Mechanical Analysis and Mechanical Composition.**—In order to be sure to which class a soil belongs, the amounts of sand, silt and clay it contains must be determined by laboratory methods designated as “mechanical analyses.” Such analyses give the “mechanical composition” of a soil; as, for example:

Dry soil	Mechanical Composition Per cent of			Soil class	Reason
	Sand	Silt	Clay *		
A—found to contain	15.7	68.1	15.8	Silt loam	Contains more than 50 per cent silt.
B—found to contain	16.9	37.9	44.4	Clay	Contains more than 30 per cent clay
C—found to contain	63.0	21.0	12.0	Sandy loam	Contains more than 50 per cent sand.

\* Per cents total 99.6—remaining 0.4 per cent consisted of stone and gravel.

**“Light” and “Heavy” Soils.**—A sandy soil, because of its high sand content, is comparatively easy to work—for this reason it is usually regarded as a “light” soil. A soil like clay, on the other hand, is termed “heavy” because it is much more difficult to till. By weight sand is the heaviest soil—clay is much lighter.

**Soil Classification Based on Mode of Formation.**—It is convenient to study soils in relation to the manner in which they were formed or built up. This gives rise to quite a different classification, as follows:

1. *Residual soils*—remaining on rocks where formed.
2. *Cumulose soils*—deposits of partially decayed vegetation.
3. *Alluvial soils*—built up by alluvium deposited by flowing water.
4. *Glacial soils*—formed through glacial action.
5. *Marine soils*—formed by sediment carried into the sea.
6. *Lacustrine soils*—formed by sediment carried into lakes.
7. *Loess (lo'ēs)*,—formed through the accumulation of dust carried by wind.
8. *Colluvial soils*—moved down steep slopes by gravity.

The first two groups are “sedentary” soils, since they have stayed where they were originally formed. The next five groups are “transported” soils—the material having been carried and laid down by water, glaciers and wind. The last named soils are so called because they moved down steep slopes, due to gravity.

**Residual soils** are underlaid by the rocks from which they were formed—such as granite, limestone, sandstone, shale and others. Wherever such soils are found the graduation of rock into soil may easily be observed. These soils are widely distributed in the United States—including the Great Western Plains and the larger portion of the Southern States, excluding the river valleys and the Atlantic and Gulf Coastal Plains.

If all the soils could have remained where they were formed then all the soils in the world derived from rocks would be residual. But this has been impossible because of the forces which have been and are still at work effecting changes on the earth.

**Cumulose soils** are deposits of vegetable matter accumulated most commonly in what used to be shallow bays, lakes and ponds, and preserved because they were covered or saturated with water. It is common to see water plants such as flags, mosses, reeds and



FIG. 7.—Diagram showing peat formation and a floating bog; *cc*, vegetable growth on surface of pond; *dd*, partially decayed organic matter accumulating on bottom; *ee*, climbing bog. (Shaler.)

sedges, growing, for example, along the shores of a pond. These plants die, sink to the bottom and are wholly or partially preserved by stagnant water which prevents or inhibits their decay. Sometimes “floating bogs” are formed which become thicker and thicker, and as they thicken gradually sink to the bottom (Fig. 7). In either case there comes a time when the shallow body of water becomes filled with a soft, spongy mass—the final stage in the formation of “peat.”

**Peat** when dry is the lightest of soils, and may be black, brown or reddish in color. It is commonly described as “raw” when the plant remains can be easily recognized, and “well decomposed” when the plant remains have lost their identity. Peat is a material much used for fuel in countries of the Old World.

**Muck.**—When considerable sediment is mixed with peat the resulting soil is called “muck.” It is more decomposed, firmer and heavier in weight than peat.

**Occurrence and Value of Peat and Muck Soils.**—Peat and muck soils occupy local areas ranging from a few to thousands of acres in extent, and they may vary in depth from a few inches to

several feet. Some are formed in fresh and others in salt water (Fig. 8). They are not confined entirely to lowlands, but may occur on hill tops and even on hill sides in depressions kept wet the year round. On many of them, in their natural state, wild grasses grow—on others trees and shrubs. When artificially well drained most of them can be converted into valuable agricultural lands.

**Alluvial soils** are found along streams, and are built of the alluvium carried and deposited by them during flood flow. When muddy streams overflow their banks, the flow over the flooded land is retarded, consequently the sand settles out, then the silt, and



FIG. 8.—A bed of peat four feet deep underlaid by a 3-foot bed of marl, which in turn is underlaid by sand and then clay.

finally the clay—if the flow is nearly or completely checked. Through this deposition, therefore, low level areas are gradually brought to higher levels. Many streams during the past ages have greatly subsided, leaving high and dry many level and productive expanses of these water-formed soils.

**The sources of the sediment carried by streams** are mainly the uplands drained by them. Heavy rains and melting snows are responsible for the land erosion so commonly seen in hilly or “rolling” sections. The sand, silt and clay particles carried into streams may be gathered from many kinds of soils and which in turn form new kinds. Geologists have estimated that the United States is being planed down at an average rate of one inch in 760 years,

but denuded slopes may lose several feet in a year. Not all the alluvium carried by rivers is deposited on either side of their courses before the sea is reached. Indeed, it has been estimated that the Mississippi river carries into the Gulf of Mexico each year an amount of sediment equivalent to a pile of sand and mud one mile square and 268 feet thick. What becomes of all this material?

When in a well drained condition, alluvial soils are usually rich and productive. Many soils are kept productive because of rich sediments deposited on them. The soils in the Nile Valley in Egypt are splendid illustrations of this natural method of fertilization.

**Glacial soils** or "glacial drift" soils are so called because the material composing them was transported, mixed and built up through the action of glaciers or huge ice sheets many thousands of years ago. Though this seems a long time, nevertheless these are regarded as young in comparison with residual soils.

**The Story of the Glaciers.**—Among the many wonderful chapters in the history of the earth recorded in rocks, mountains, hills and valleys, that of the Great Ice Age is comparatively easy to interpret. Abundant evidence points to the fact that at some remote time the greater portion of the northern part of North America was covered by great sheets of ice resulting from the accumulation of snows due to climatic changes. These great ice sheets moved southward and invaded the northern part of what is now the United States. In the central portion the ice extended as far south as the Missouri River and southern Illinois, Indiana and Ohio (Fig. 9).

The Ice Age, especially so far as the north central portion of the United States is concerned, does not mean the invasion and melting of just one immense ice sheet or glacier, but it includes at least five great and separate ice periods. During some of these periods, notably the first ones, the ice sheets extended farther west and south than during other periods. The effect of the Kansan Drift, one of the first invading ice sheets, is best observed in Kansas, hence the name. This is supposed to have occurred not less than 400,000 years ago. The last invasion, made during the Wisconsin Glacial Period, is estimated to have occurred 20 to 50 thousand years ago. There is strong evidence to indicate that between each of the five ice periods or stages the climate was tropical or semi-tropical.



**Effect of the Glaciers.**—These invading and melting ice sheets produced profound effects upon the country over which they moved. In thickness they varied from a few feet at their margins



FIG. 9.—Map showing the extent of the ice sheet over North America. Note the driftless area, covering a portion of what is now Wisconsin, Iowa and Illinois. (Chamberlain and Salisbury.)

to several thousand feet at their centers. They were thick enough to slide over the high mountains of the New England States. In their movement rocks were ground to powder, the pre-existing soil mantle was swept away, some old valleys were filled up and new ones were gouged out, rivers were turned from their

courses, and, when the ice melted a new soil called "glacial drift" was laid down. Most of this "drift" material was not carried



FIG. 10.—Whence came this large boulder? The glaciers brought it many miles from the north. The machine in the background is a stone puller. (Wisconsin.)



• FIG. 11.—Kames—round and oval hills formed through glacial action. Wisconsin Geol. Survey. (Fenneman.)

any great distance by the glaciers, though the streams which ran from the melting ice carried much sediment miles beyond the area covered by the ice sheets, and deposited it, as alluvium, in their valleys.

Low ranges and hills consisting of "glacial till" or "boulder clay" were brought into existence. At this time, too, numerous lakes were formed, many of which have long since filled up or disappeared. "Rolling" topography and scattering boulders of all sizes and kinds are other characteristics of a glaciated country (Figs. 10 and 11).

**Quality of Glacial Soils.**—In general, glacial soils have wide variations; many are comparatively "heavy," hence silt and clay loams are common. Some are very stony (Fig. 12), and many are in need of drainage. Great variations exist as to their agricultural value.



FIG. 12.—The inside of some of the glacial deposits. This deposit consists of very stony and gravelly glacial till. Wisconsin. (King.)

**Marine and lacustrine soils** are soils derived from material accumulated on the sea bottom and in glacial lakes, respectively. The coarser and heavier particles settled to the bottom near shore, and the finer silt and clay were carried out into deep water. These deposits vary in thickness, and in case of marine deposits particularly, commonly consist of layers of coarse and fine material. Because of changes in the earth during the past ages—such as the disappearance of old lakes and rise in land elevations, much of this material deposited in the sea and lakes during ages past has become exposed and is now called marine or lacustrine soil as the case may be. Nearly all the soils of the Atlantic and Gulf Coastal Plains are of marine origin. They are especially adapted to the growing of cotton, corn, peanuts, melons and fruit.

The fertile soils in the valley of the Red River of the North and of many large areas bordering on the Great Lakes are of lake origin.

**Loess** (lo'és) is soil formed through the accumulation of dust blown and dropped in favoring localities by wind during long periods of time. These deposits, no doubt, were centuries in formation, beginning after the disappearance of the glaciers. During the Ice Age much fine material was carried many miles south of the ice sheets by running water coming from the melting glaciers. Immense quantities were deposited in what is now the Missouri Valley. After the glaciers melted away it is believed a long dry period followed during which time strong westerly winds picked up this fine material and dropped it over thousands of square miles in the central part of the Mississippi Valley. Loess is also found in Washington, Oregon and other parts of the United States. These deposits vary in thickness from a few inches to many feet. In China loess is found covering immense areas, in some places extending in depth to several thousand feet.

Loess soils are free from stones, and are considered the richest soils in the world. The fact that the famous Corn Belt of the Mississippi Valley includes much loess is indicative of its productiveness.

**Colluvial soils** are found at the bottom of steep slopes—they accumulate there because of the force of gravity. Sometimes avalanches bring about the quickest downward movement of soil and rocks from the steep slopes. From the nature of their formation these soils must necessarily consist of more or less mixed material. Often they are made up largely of fragments of rocks brought down by gravity from the heights above. Generally they are coarse, loose soils and not well adapted for cultivation.

**Soils Easily Described.**—Now that we have learned how soils may be grouped into classes according to their texture, and how they differ in the manner in which they were formed, we can easily describe them, and in a general way, distinguish one kind from another; for example, we may have a residual silt loam on limestone, or a residual sandy soil on sandstone, or a glacial clay loam, an alluvial sandy loam, a glacial loam, or a loessial silt loam, etc.

#### SOIL TYPES

**Soil Mapping.**—The United States Bureau of Soil in coöperation with the several states and territories has surveyed and





FIG. 13.—The United States is divided into thirteen soil provinces and regions.



WILLIAMS ENGRAVING CO., NEW YORK

Facilitate the correlation of soil types and series. (Bureau of Soils Bul. 96, 1913.)



Figure 1. A map showing the distribution of the species in the study area. The map is divided into several regions, and the distribution of the species is indicated by the shaded areas. The map is oriented with North at the top.



mapped hundreds of thousands of acres of soil. Each soil map is accompanied by a report describing in detail the nature and agricultural value of the soils surveyed. These surveys are usually made by counties and are based on the theory that all soils are not equally suited to the production of the same crops.

**One Loam May Differ Widely from Another.**—Though a class of soil consisting of about half sand and the remaining half silt and clay, for example, is a loam wherever found, yet a loam in Wisconsin may differ in ten distinct ways from a loam in Mississippi, and have dissimilar crop adaptation. In order, therefore, to distinguish clearly between these two particular loams, long descriptions must necessarily be given each one, concerning manner of formation, kind of material from which formed, natural drainage, color, amount of organic matter, structure, subsoil and certain chemical properties.

**Distinguishing of Soils Simplified.**—In soil mapping it would be very inconvenient, indeed, if it were not possible to designate the different soils without describing each in its fullest detail, especially since there are so many different kinds of soils in the United States to be correlated.

Soil descriptions concerning origin, etc., may be expressed in single words; for example, "Dunkirk," "Greenville," etc. These names used in describing soils are derived from the name of some town, village, county or natural feature existing in the section or region where the soil is first identified or is best developed.

*Dunkirk*, as it is used in describing soils, implies that such soils are derived from sandstone, shale and limestone material carried as sediment into pre-existing glacial lakes; they have good natural drainage; are gray to brown in color, and have a yellowish or light brown subsoil. These soils are desirable for general farming.

*Greenville* is a descriptive name signifying that such soils are of marine origin—built up by material washed from the Piedmont-Appalachian region into the ocean which at one time encroached upon the continent; they are red in color; have a dark red subsoil; and are friable and well drained. They are well adapted to cotton, corn, forage crops and oats.

Wherever a loam is found to which will fit the description implied in "Dunkirk," that soil is specified as "Dunkirk loam." And wherever a loam is found to which the descriptive term

“Greenville” may be applied, that soil is specified as “Greenville loam.”

Soils specified in this manner are called “types.” Thus “Dunkirk loam” and “Greenville loam” are the names of two types of soil.

**Soil Type Defined.**—A soil type may be defined as soil that has similar characteristics regarding texture, mode of formation, origin of material, color, natural drainage, organic matter, and subsoil.

**Types may be Grouped into Series.**—Soil types may be classified or arranged into groups called “series.” This is possible because two or more soil types may have the same general characteristics regarding mode of formation, range of color, etc. For example, we have the following types grouped into a series:<sup>1</sup>

Dunkirk sand	}	= A soil series. (Dunkirk series.)
Dunkirk fine sand		
Dunkirk sandy loam		
Dunkirk fine sandy loam		
Dunkirk loam		
Dunkirk silt loam		
Dunkirk clay loam		
Dunkirk clay		

In a similar manner are derived Greenville series, Miami series, Volusia series and many others. The soil types composing a series differ mainly in texture and productive power.

**Soil Series Defined.**—A soil series may be defined as a group of soil types similar in all respects except in texture and productiveness.

**Soil Classification in Soil Survey.**—In soil survey and mapping, type is the unit used in soil classification. Types having similar general characteristics aside from texture are classified in series.

To facilitate the correlation of soil types and series the United States Bureau of Soils has divided the United States generally into thirteen soil provinces and regions (Fig. 13). The types of soil derived through glacial and wind actions are to be found largely within the Glacial and Loessial province. Types of lake origin are included in the Glacial Lake and River Terrace province. Types of marine origin are to be found in the Atlantic and Gulf Coastal Plains province, etc.

<sup>1</sup>The word “series” may be used in both a singular and plural sense.

**More About Soil Types.**—It is to be observed that a type name is usually made up of the name of a soil class added to a name which indicates its general characteristics and which determines the series to which it belongs as:

Dunkirk sandy loam  
(series) (soil class)

Knox silt loam, Cecil loam, Dekalb silt loam, Hagerstown loam, Genesee loam, Bozeman silt loam, Gila silt loam and Salt Lake loam are eight types representing as many series. Though these types are widely scattered throughout the United States, yet they may be grouped into two classes; viz., loam and silt loam.

It is possible to have two types differing from each other in several distinct ways, or in just one respect.

Peat and muck are two special types of soils.

Peat may be defined as a soil type consisting of from 50 to 95 per cent organic matter (p. 16).

Muck may be defined as a type of soil which consists of from 15 to 50 per cent of well-decomposed organic matter and 50 to 85 per cent mineral matter. The mineral matter in muck consists of sand, silt and clay particles deposited by water or wind during its formation.

Meadow may also be considered a special, or miscellaneous, type of soil, meaning first bottom land which is low, poorly drained, and subject to overflow. The texture is so variable that no separation into established types can be made.

It is possible on some large farms to map a dozen or more types which may be grouped into three or more series.

Within a single state more than a hundred types of soils have been mapped—in Wisconsin, for example, more than 125 types grouped into more than 30 series.

In the United States there have been mapped thus far more than 2900 types classified in more than 740 series (Fig. 13).

**Illustration Material for Lessons.**—1. Two or three samples of soil—natural and with organic matter burned out. Note loss of weight, change of color and any other changes.

2. Samples of various colored soils—include some subsoils. Why do soils vary in color?

3. Glacial pebbles and any other material showing glacial action.

4. A soil map to show how soils are mapped.

5. Three or more types of soil belonging to the same series to illustrate soil classification according to type.

6. A state map to illustrate land description—township, range, section, etc.

**Demonstrations.—Materials Needed.**—Four large, clear-glass bottles; a small amount of clean sand, silt, some clay, and two or more tablespoonfuls of loam.

**To Show the Comparative Rate of Settling of Sand, Silt and Clay Particles Out of Water.—Procedure.**—Have prepared 4 large, clear-glass bottles and fill each about three-quarters full of water. Place in one some sand, in another some silt, in the third some clay, and in the fourth a tablespoonful or more of loam. Cork. Shake each thoroughly, invert, and note the rate of settling of the soil particles.

**Questions.**—(a) Why should the banks of a stream which overflows often be higher than the land farther back?

(b) A river flows southward. In the middle of the stream is a sand island which becomes covered at high water. On which end (north or south) of the island will the fine sand be found? Why?

(c) During a heavy rainstorm a gully was formed on a sloping field of heavy silt loam soil. Below the mouth of the gully on the field below considerable sand was deposited. Where did the sand come from?

**Laboratory Exercises.—Materials Needed.**—A hand lens; a high power microscope if available; a dozen tumblers or other dishes; a small baking powder can; 2 to 4 quarts of each of the eight important soil classes, also muck and peat; a balance; soil maps; state map showing township and range.

**To Examine the Building Material of Soils.—Procedure.**—With the aid of a hand lens examine a pinch of sand and a pinch of loam. Distinguish between sand, silt and clay particles. (Set up a high power microscope if convenient.)

**Questions.**—What are sand particles? Silt? Clay particles?

**To Study Soil Structures.**—(Arrangement of soil particles.) **Procedure.**—With the aid of a hand lens examine the structure of a mass of clay. Of sand. Of crummy silt loam. Illustrate observations with drawings.

**Questions.**—(a) Of what materials are soil crumbs composed?

(b) What binds the soil particles into crumbs or granules?

**To Study Texture of Soils.—Procedure.**—Place in tumblers or in other convenient dishes, dry and typical samples of the eight important classes of soil (based on texture). Vary the color as much as possible, and have duplicates of some of the classes. Provide a moist sample of each. Include muck and peat in this exercise. Record results as follows:

Soil classes named in order according to texture	How distinguished *			Characteristics Note "feel," whether gritty, velvety or sticky
	Per cent sand	Per cent silt	Per cent clay	

\* Teacher should supply percentage ranges of sand, silt and clay.

**Questions.**—(a) Explain this statement—"A sand is not necessarily all sand."

(b) Give meaning of "A clay must contain at least 30 per cent clay."

(c) What is a loam?

(d) What is a loamy soil?

(e) What makes a soil loamy?

(f) What is a heavy silt loam?

**To Distinguish Soil Classes.**—*Procedure.*—Proceed as in Exercise No. 3, only number the samples instead of naming them. Provide a new set of samples if possible. Include muck and peat in the unknowns. Determine the soil classes.

**To Determine the Difference in the Weight of Soils.**—*Procedure.*—Fill a small baking powder can full of air-dry sand and weigh. In the same manner weigh a dry sandy loam, a silt loam, a clay, a muck, and a peat. Use a 20-mesh screen to separate out all coarse particles. Record results as follows:

Soil	Weight of soil plus can	Weight of can	Weight of soil

*Questions.*—(a) What is a so-called “heavy” soil?

(b) “Light” soil?

(c) What per cent heavier is the dry clay than the peat?

(d) What per cent heavier is the dry sand than the peat?

**To Learn How to Use a Soil Map.**—*Procedure.*—Procure from the State Experiment Station, College of Agriculture or from the United States Department of Agriculture several soil maps of counties in the state. Select one county map and answer the following questions:

(a) Soil map of what county?

(b) Give the boundary of the county in terms of township and range.

(c) Does this description check with that on the state map?

(d) Name the predominating soil classes found in the county.

(e) Name the predominating soil types found in the county.

(f) Give the land description of the section of land in the northwest corner of the county.

(g) Name the types of soil mapped in this section.

**Field Studies.**—1. Observe different soils based on mode of formation.

2. Observe different types of soil and note why different types.

QUESTIONS

1. What are the common meanings given to “soil”? Subsoil?
2. What does a farmer mean when he says, “My soil is three feet deep and is underlaid by sandy clay?”
3. In our study of soils in relation to crop production what is the meaning of soil to be understood? What then is subsoil to mean?
4. Name and describe the soil components.
5. Is soil a simple or complex substance? Explain.
6. What is the most convenient way of classifying soils?
7. Distinguish between soil texture and structure. What makes a soil coarse textured or fine textured? What structures may soils have?
8. Name the eight principal soil classes based on texture in order from the coarsest to the finest textured. Give meaning of soil class.
9. A certain soil is found to contain 2 per cent coarse sand, 3 per cent medium sand, 22 per cent fine sand, 35 per cent very fine sand, 27 per cent silt, and 10 per cent clay. To what class does this soil belong?
10. What two meanings may be given to “sand”? To clay?
11. What is meant by “loam”? Clay loam? Fine sandy loam? Gravely loam?
12. How are “marsh” and “swamp” soils to be regarded?

13. What is meant by the mechanical composition of a soil?
14. Distinguish between "light" and "heavy" soils.
15. What are residual soils? Is peat one of them?
16. Name and describe the transported soils.
17. Tell the story of the glaciers.
18. What is peat? Describe its formation. What is "raw" peat? What is muck?
19. Can we have soils that may be described as residual alluvial soil; stony loess; glacial sandy loam; or cumulose silt loam? Explain.
20. What is soil mapping?
21. How may a loam differ from another loam? How may the two be distinguished from each other?
22. What is a soil type? Illustrate.
23. How may soil types be classified or grouped?
24. What is meant by a soil series?
25. Are peat and muck soils to be regarded as classes or types of soil? Distinguish clearly between peat and muck. What is meadow?
26. Describe the conditions which lead to the formation of a "marsh" or "swamp" soil which you have seen.
27. For an outline summary of the chapter see table of contents.

## CHAPTER III

### CHEMICAL COMPOSITION OF SOILS AND ITS RELATION TO PLANTS AND ANIMALS

IN the previous chapter it has been shown how the physical composition of soils, their mode of formation, and their characteristics have given rise to several classes and many types of soils. In this chapter soils shall be considered from a chemical point of view, and in this respect their relation to plants and animals noted.

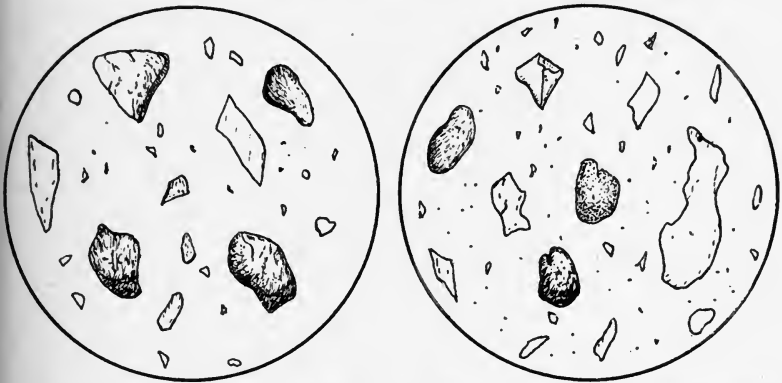

FIG. 14.—A few soil grains enlarged. A sand particle or a clay particle may represent a combination of the elements silicon and oxygen; or a combination of potassium, aluminum, silicon and oxygen, etc.

**Soil Materials Composed of Elements.**—The building materials of soils, as has been learned, are mineral particles and organic matter. These substances, like all material things, are composed of chemical elements.<sup>1</sup> Thus, when a soil is taken into a chemical laboratory and analyzed, its chemical composition is obtained and this composition, as of nearly all substances, may be expressed in two ways; viz., as *elements* and as *oxides* of elements; that is, the elements united with oxygen (Fig. 14).

**Chemical Composition of Soils.**—In order to make simple and

<sup>1</sup>Chemical elements are substances that cannot be reduced to anything else. For example, iron, carbon, hydrogen and oxygen are elements, since they cannot be split up into anything else. Water is not an element because it can be reduced to something else; viz., two elements—hydrogen and oxygen.

plain the chemical composition of soils, the following table has been constructed which may serve as a key to the knowledge of chemistry required in further study. Only the more common and important elements are named. The more common oxides are also named for the purpose of avoiding any confusion when these names are used. The chemical symbols<sup>2</sup> and formulas will help to fix in mind the differences between some of the elements and their oxides.

*Chemical Composition of Dry Soils Expressed as Elements and Some of Their Oxides*

Mineral elements	Symbols of elements	Oxides of elements	Formulas of oxides
Silicon.....	Si	Silica.....	SiO <sub>2</sub>
Aluminum.....	Al	Alumina.....	Al <sub>2</sub> O <sub>3</sub>
<i>Iron</i> .....	<i>Fe</i> *	Iron rust.....	.....
<i>Calcium</i> .....	<i>Ca</i>	<i>Lime</i> .....	<i>CaO</i>
<i>Magnesium</i> .....	<i>Mg</i>	<i>Magnesia</i> .....	<i>MgO</i>
Sodium.....	Na *	.....	.....
<i>Potassium</i> .....	<i>K</i> *	"Potash".....	K <sub>2</sub> O
<i>Phosphorus</i> .....	<i>P</i>	"Phosphoric acid".....	P <sub>2</sub> O <sub>5</sub>
<i>Sulfur</i> .....	<i>S</i>	Sulfur fumes.....	SO <sub>3</sub>
[Non-mineral]			
Carbon.....	C	Carbon dioxide.....	CO <sub>2</sub>
<i>Nitrogen</i> .....	<i>N</i>	.....	.....
Hydrogen.....	H	.....	.....
Oxygen.....	O	.....	.....

\* It is to be observed that the symbols of ten of these elements are derived from their common names. The symbols for iron, sodium and potassium are derived from their Latin names; viz., ferrum (Fe), natrium (Na) and kalium (K).

**Elements Exist in Combined Forms.**—These elements do not exist in soils separate from each other, but occur in united forms. Two or more are combined to form the soil particles which can be seen. For example, a sand, silt or clay particle may represent a combination of silicon and oxygen; or potassium, aluminum, silicon and oxygen; or calcium, magnesium, carbon and oxygen, etc. A particle of organic matter may represent a complex combination of nitrogen with practically all the elements.

**The Elements and Their Characteristics.**—**Oxygen** is the most common and abundant element on the earth. In the free state it is a colorless, odorless and tasteless gas slightly heavier than air,

<sup>2</sup> Chemical symbols are abbreviations to represent chemical elements and formulas represent compounds. For example, the symbol for oxygen is "O," for carbon "C." The formula for water is "H<sub>2</sub>O," meaning water is oxygen united with two atoms of hydrogen.



and slightly soluble in water. It is a very active substance, combining directly with nearly all the known elements at ordinary temperature. A compound formed through the union of any element with oxygen is called an oxide. Water is the oxide of hydrogen ( $H_2O$ ). Iron rust is the oxide of iron. At high-temperature oxygen combines vigorously with carbon with accompanying evolution of heat and light, as in burning.

Oxygen is necessary for all animal life. Good blood owes its red color to a good supply of oxygen. It is of interest to know that nearly one-half of an average soil is oxygen by weight. Water is 90 per cent oxygen. By weight, air is 23.2 per cent oxygen. Rocks of the earth consist of 44 to 48 per cent of this element.

**Silicon.**—Next to oxygen, silicon is the most abundant element. More than one-fourth of the crust of the earth is silicon. Quartz sand is the oxide of silicon. Some mountains are largely silicon oxide. In its free state silicon is a brittle solid, having a metallic luster.

**Aluminum** is widely distributed in nature, constituting 8 per cent of the earth's crust. It has a great attraction for oxygen. It is found in pure clay and in nearly all common rocks. In the pure form aluminum is a silver-white, lustrous metal about one-third as heavy as iron. It is used largely in the manufacture of cooking utensils and for many other useful things, such as paint, alum, etc.

**Iron**—Pure iron is a white and fairly soft metal. It rusts easily in moist air and in salty solutions. Many farmers put grease on plow mold-boards and cultivator teeth to keep off the oxygen and thus prevent rusting. Iron is very abundant and widely distributed. All soils and rocks contain iron in some combined form.

**Calcium** is always found in combined forms because it is a very active element. In its pure form calcium is a fairly hard, silver-white metal. This is a widely distributed element. It is an important constituent of bones, egg shells, limestone, coral, marble and natural chalk.

**Magnesium** is widely distributed in nature, and occurs in large quantities. As an element it is a silver-white metal which burns in the air with a brilliant white light. More than one-half of flash light is magnesium powder. Many magnesium compounds are found in soils. Certain common rocks (dolomitic limestone) are composed of calcium and magnesium carbonates in nearly equal proportions.

**Sodium** is never found in the free state, but always combined with other elements. At ordinary temperature sodium is soft like wax, and it is so active that it must be kept under petroleum oil to exclude all oxygen and moisture. Common table salt is sodium combined with chlorine (sodium chloride). All sodium came originally from rocks.

**Potassium** is very similar to sodium in its chemical properties. This element is never found in its pure form. Like sodium, it is a soft, silver-white, wax-like metal which reacts vigorously with water. Pure potassium, therefore, must be kept under petroleum oil. Potassium is widely distributed in nature. A considerable amount is present in mineral soils. It is found in the ash of plants in the form of a compound called potash. Large amounts of potassium salts are found in Germany and France. Potassium is a common constituent of potash fertilizers.

**Phosphorus** does not occur alone in nature because of its great attraction for oxygen. In its pure form it is a pale yellow, wax-like solid and very poisonous. Phosphorus is also a very active substance. Since it catches fire easily in air it has to be kept under water in air-tight cans. Phosphorus is a common constituent of bones and of compounds called phosphates. Soils contain a comparatively small amount of this element. Most phosphorus of commerce is used in making matches.

**Sulfur** is a common substance. It is yellow in color and may occur as crystals or as flour. Many rich deposits of sulfur are found in Texas, Louisiana and Mexico. It is also found in combination with some of the metals, as lead, iron, zinc, etc. Sulfur is much used in the making of sulfuric acid, black gun-powder, hard rubber, etc.

**Carbon** occurs in the free state as charcoal, graphite, coke, soot, lampblack, bone black, diamonds, etc. Large quantities of carbon are found in the form of coal, which represent the remains of vegetation of past geological ages. Carbon is the most important constituent of all plants and animals. When carbon burns it unites with oxygen and forms carbon dioxide gas ( $\text{CO}_2$ ). Carbon in the soil is found mostly in the organic matter and carbonates.

**Nitrogen** in its free state is a colorless, odorless, tasteless and inert gas. Air is 76.8 per cent nitrogen by weight. In the gaseous form nitrogen does not combine to assist in life processes, yet in combined form this same element is absolutely essential to all life.

The original source of all nitrogen is the atmosphere. Nitrogen is the important element in ammonia and in all nitrates. In the soil it is found mainly as compounds in organic matter.

**Hydrogen** in its pure form is a colorless, odorless and tasteless gas. It is the lightest of all known substances. It is the most widely distributed element in the universe, being found in the sun and the stars. On the earth it is found mostly combined with other elements. It is an essential constituent of water. When hydrogen gas burns, the resulting compound is water—hence the name *hydrogen* (water generator). Hydrogen is an essential part of all plants and animals.

**The Mineral Elements.**—Silicon, aluminum, iron, calcium, magnesium, sodium, potassium, phosphorus and sulfur are frequently called the *mineral elements* (see table).

**The Elements Crops Take From Soils.**—The elements that crops take from the soil components and which are absolutely necessary for plant growth are iron, calcium, magnesium, potassium, phosphorus, sulfur and nitrogen. All of these except nitrogen are the essential mineral elements required by all crops.

**The elements most commonly deficient in soils** and which affect crop yields the most are nitrogen (N), phosphorus (P), and potassium (K). These three are, therefore, commonly regarded as the fertilizing elements. With these might be included calcium (Ca). Some regard sulfur fully as important as phosphorus in crop production. Conclusive evidence, however, is lacking. Some tests seem to show that certain soils require sulfur to aid in obtaining larger crop yields.

**Supply of Important Elements not Large.**—The total amount of these four elements in a sand is more often less than 2 per cent; in a productive silt loam often less than 5 per cent. The soil supply of nitrogen, phosphorus, potassium and calcium, therefore, is not large.

Of the essential elements, crops require the least iron, yet soils are rich in iron. Generally speaking, more than 85 per cent of soils consists of oxygen, silicon and aluminum. This oxygen exists in the soil in the form of insoluble compounds and is not used by plants. Both silicon and aluminum are non-essential to plant growth.

**How Nitrogen is Held in Soils.**—Nitrogen in free form is a gas, a component of air. The nitrogen which makes up a part of the composition of soils is held in soils largely as organic matter.

Before plants can secure this nitrogen for their growth the organic matter must decay. In a similar manner the mineral soil particles must decay or partially dissolve before plants can obtain the essential mineral elements.

**Lime, Its True Meaning.**—Lime is the oxide of the element calcium, or calcium oxide ( $\text{CaO}$ ). Pure burnt lime or quick-lime is nothing else than calcium oxide. Lime does not exist in soils in the form as indicated by its symbol; it is to be found in more complex substances. It is to be remembered that the calcium content of any substance may be expressed as per cent calcium ( $\text{Ca}$ ) or as per cent lime ( $\text{CaO}$ ).

**Potash, Its Common Meaning.**—The word *potash* is commonly used to mean the oxide of the element potassium, or potassium oxide ( $\text{K}_2\text{O}$ ).<sup>3</sup> Its true meaning, however, is potassium carbonate, a soluble alkali salt obtained by leaching wood ashes. True potash is not a substance that can be represented by the formula ( $\text{K}_2\text{O}$ ); it is a more complex substance, as indicated by the formula  $\text{K}_2\text{CO}_3$ .

The potassium content of soils or of any fertilizing material may be expressed as per cent potassium ( $\text{K}$ ), and commonly as per cent "potash" ( $\text{K}_2\text{O}$ ).

"**Phosphoric acid**" is the name frequently given to the oxide of the element phosphorus, ( $\text{P}_2\text{O}_5$ ).<sup>4</sup> It does not exist in nature; nevertheless it can be made in a chemical laboratory.

The phosphorus content of soils or of any fertilizing substance may be expressed as the element phosphorus ( $\text{P}$ ), and as it is frequently expressed, as phosphoric acid ( $\text{P}_2\text{O}_5$ ).

**Chemical Composition of Soils Influences Plant Growth.**—This brief discussion concerning the chemical composition of soils is sufficient to give us the idea that a loam, silt loam or any other class or type of soil is a complex chemical substance down into which land plants send their roots, not only to anchor themselves but to obtain water and elements necessary for growth. It is reasonable, therefore, to believe that the chemical composition of soils influences the growth and development of plants in a greater or less degree (Fig. 15).

**Chemical Composition of Plants Similar to That of Soils.**—For centuries no one knew just what plants were made of or how they

---

<sup>3</sup> The formula  $\text{K}_2\text{O}$  means two atoms of potassium united with one atom of oxygen.

<sup>4</sup> The formula  $\text{P}_2\text{O}_5$  signifies the union of two atoms of phosphorus with five atoms of oxygen.

grew. About 290 years ago it was thought that a plant was nothing more than water that had undergone a mysterious change in the soil. Only within comparatively recent years has it been found that the chemical composition of plants is quite similar to that of soils.

**The elements required by plants and without which they cannot grow are ten in number; viz., nitrogen, phosphorus, potassium, calcium, magnesium, sulfur, iron, carbon, oxygen and hydrogen. All the mineral elements are to be found in ashes.**

Silicon, sodium, aluminum and other elements are found in ash but they are not necessarily essential to plant growth, since plants can grow without them. Ash, then, is the mineral portion of plants.

### Sources of Elements Plants Require.—Plants

secure the elements they require from the following sources:

1. *The soil*—furnishing nitrogen and mineral elements.
2. *The soil water*—furnishing oxygen and hydrogen.
3. *The air*—furnishing carbon and oxygen.

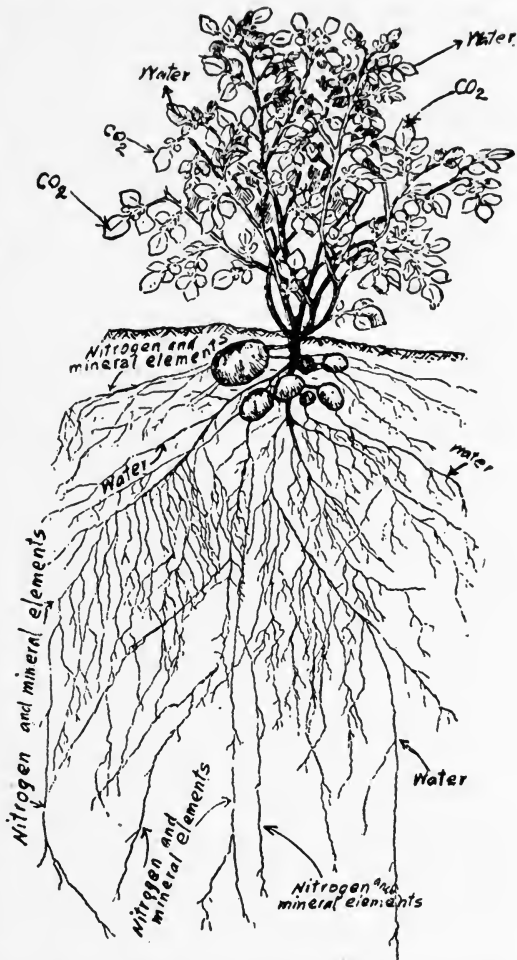

FIG. 15.—The root system of a potato plant in a permeable soil. This also illustrates the sources of the elements required by plants. (After Rotmistrov.)

**How Plants Secure Their Nitrogen and Carbon.**—Plants do not and cannot use nitrogen in its gaseous form, hence they do not take in any nitrogen directly from the air through their leaves. All nitrogen used by plants is taken in through their roots.<sup>5</sup>

Practically all the carbon contained in plants is taken directly from the air through the leaves in the form of carbon dioxide (CO<sub>2</sub>).

**Much Carbon is Used by Plants.**—A bushel of shelled corn contains about 25 pounds of carbon and one pound of ash. A ton of clover hay contains 950 pounds of carbon and about 140 pounds

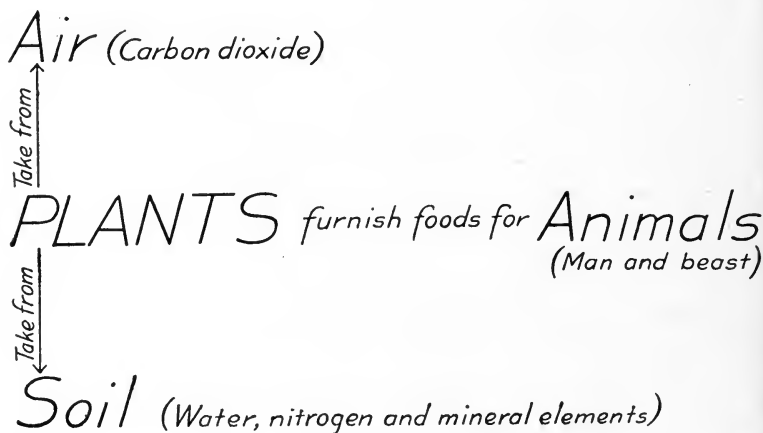

FIG. 16.—The relation of plants to the soil and air on the one hand and to animals on the other.

of mineral matter (ash). These two facts show the importance of both carbon and mineral elements in the production of crops.

**Chemical Composition of an Animal Body is Similar to That of Plants and Soil.**—Plants are consumed by animals, and this means that the elements composing the animal body are secured mainly from plants. Thus it is not surprising that the chemical composition of an animal body should be similar to that of plants. The ash of an animal body contains the same kinds of mineral elements as are found in the ash of plants and in soils. In reality, therefore, the ash of an animal body is nothing more than the “dust” of the

<sup>5</sup>This seems contrary to general opinion especially as regards clover, alfalfa and other legumes. The nitrogen gathered by the bacteria within the nodules on the roots of legumes is absorbed by the roots.

earth. In this connection no truer statement was ever made than that written more than three thousand years ago:

In the sweat of thy face shalt thou eat bread, till thou return unto the ground; for out of it wast thou taken—for dust thou art and unto dust shalt thou return.—Gen. 3 : 19.

**The Great Work of Plants.**—The elements which compose an animal body are gathered from various sources, and as such they are only in one of the stages or forms in the cycles through which they pass. A speck of phosphorus, for example, contained in an animal body may have been gathered from a cabbage head or a turnip; it tarries there for a lifetime, then continues its wanderings through the ages; and the only way it can again become a "building block" in an animal body is to become built up in the tissue of some edible plant.

Plants not only furnish building materials for animal bodies, but they also supply them with fuel for heat and energy. Thus a great work of plants is to bring together carbon, oxygen, nitrogen, mineral elements and water and build them into foods for man and beast.

**The Farmer's Business.**—Since man and beast must eat to live and grow, the farmer's big business is to raise those plants which have been found good for foods. Not only must he provide foods but materials for clothing as well. In order that the farmer might do this most successfully he must understand soils and the principles upon which crop production depends.

**Demonstration.**—*Materials Needed.*—Material and apparatus necessary to generate and demonstrate characteristics of oxygen, hydrogen and carbon dioxide gas: Samples of the elements aluminum, calcium, magnesium, sodium, potassium, phosphorus and carbon; lime, wood ashes, one-fourth of a pound of dry grass or clover hay, a baking powder can.

1. *Object.*—To demonstrate the properties of oxygen, aluminum, calcium, magnesium, sodium, potassium, carbon, hydrogen, lime and carbon dioxide.

2. *Object.*—To explain the true meaning of potash.

*Procedure.*—Fill a baking powder can, having a perforated bottom, with wood ashes and leach out the potash. Evaporate.

3. *Object.*—To show that plants contain mineral matter.

*Procedure.*—Burn about 4 ounces of dry grass or clover hay and note the residue.

*Questions.*—(a) What are ashes?

(b) Where did this material come from originally?

(c) What escaped during the burning?

(d) What part of clover hay is carbon?

(e) What is the per cent ash content of clover hay?

## QUESTIONS

1. How may the chemical composition of soils be expressed? Distinguish between element and oxide.
2. Name the more important elements of which soils are composed. Give symbol for each. (See table.)
3. In what form do the elements occur in soils?
4. Name four of the soil elements with which you are more or less familiar.
5. Describe the elements calcium, magnesium, sodium, potassium and phosphorus.
6. Which is the most common and abundant element on the earth? In the universe?
7. Name the common mineral elements contained in soils.
8. Name the essential elements which crops take from soils.
9. Which elements are most commonly deficient in soils and which affect crop yields the most?
10. Name the elements commonly regarded as the fertilizing elements.
11. What can you say concerning the amount of the four most important elements in soils?
12. How is nitrogen held in soils?
13. Of what importance is decay in plant growth?
14. What is meant by lime?
15. Distinguish between potassium and the common meaning of "potash." Between phosphorus and "phosphoric acid."
16. What is potash?
17. In what two ways are soils of use to plants?
18. How does the chemical composition of plants compare with that of soils? What are ashes?
19. Name all the elements required in plant growth. What are the sources of these elements?
20. Do plants take in nitrogen through their leaves? How then do they get this element?
21. How do plants get their carbon?
22. What per cent of a corn kernel is carbon? Of clover hay?
23. How does the chemical composition of an animal body compare with that of plants and the soil?
24. What is a great work of plants?
25. What is the business of the farmer?
26. Compare the amount of wood fuel or coal burned in a stove in your home with the amount of ashes removed. Explain.
27. For summary of Chapter III in outline form see table of contents.



## CHAPTER IV

### HOW ROCKS AND CLIMATE AFFECT SOILS

AMONG the factors which determine soil types was mentioned "kind of material" which refers largely to the kind of rock from which the mineral particles came. Any traveler interested in soils can easily observe the marked effects that rocks and climate have upon soils in different sections of the country. In this chapter we shall consider some of these effects both from a physical and chemical point of view in order that we may understand certain facts and soil conditions that may come within our observation, experience, or reading.

#### ROCKS IN THEIR RELATION TO SOILS

**Kinds of Rocks and Their Changes.**—There are many kinds of rocks, all of which may be divided into three main groups, according to the manner in which they were formed.

**Igneous rocks** were the first to form on the earth. They are also formed by the solidification of molten material from within the earth. Lava rocks formed through volcanic eruptions are, therefore, igneous rocks. Other igneous rocks are granite, basalt, and syenite.

**Sedimentary rocks** are bedded rocks formed from sediments such as sand, shells, mud, etc., deposited in sheets through the action of water and wind—mostly through water action. Through pressure and cementation these sediments gradually change into rocks; such as sandstone, limestone and shale. Most sedimentary rocks have been formed under sea water. All materials forming these rocks came originally from igneous rocks. Sedimentary and igneous rocks may change into metamorphic rocks.

**Metamorphic rocks** are so called because they are rocks which, through long periods of time, have changed their structure as a result of great pressure, heat, and water solutions. Slate, marble, quartzite, and schist are examples. A limestone may change into a marble, which, under proper conditions may further change its structure and become a schist. Thus a sedimentary rock may change into a metamorphic rock, and, in turn, may undergo a further change sufficient to be designated as another kind of metamorphic rock; namely, a schist.

**A Rock is an Aggregate of Mineral Particles.**—On examining rocks closely we find them composed of mineral particles massed or cemented together.<sup>2</sup> In some rocks, as sandstone, the particles are mostly of the same kind. In others they are of different kinds. In a granite, for example, the dissimilar particles may be easily distinguished by differences in hardness, color and crystal form. They are called “rock-forming minerals.”

**Rock-forming Minerals of Many Kinds.**—We shall not attempt to study all the many kinds of minerals of which rocks are composed, but only the more common and important ones as are given in the following table:

*The Common and Important Rock Minerals*

Minerals	Relative abundance in crust of earth, %	Elements of which they are composed (p. 30)
Feldspars.....	48	Si, Al, Na, Ca, K, O.
Quartz.....	35	Si, O.
Micas.....	8	Si, Al, Na, Ca, Fe, Mg, K, O.
Hornblende, angite, etc.....	1	Si, Al, Na, Ca, Fe, Mg, O.
Calcite	} all others.....	Ca, O, C.
Dolomite		Ca, Mg, O, C.
Apatite		Ca, P, O, Fl.
Hematite		Fe, O.
Pyrite		Fe, S.
Gypsum		Ca, S, O.

A study of the chemical composition of these rock minerals will make clear to us the source of the mineral elements necessary for plant growth.

No nitrogen is found in any of these minerals.

Quartz particles are the grains of which sandstones are mostly formed.

**Why Some Soils Are Deficient in Some of the Important Mineral Elements.**—A sandy soil composed of quartz sand, or derived from pure sandstone would naturally contain only a very small amount of the important mineral elements. Why?

Soils composed of mineral particles derived from rocks containing such minerals as feldspars, hornblende, micas, apatite, etc., are usually well supplied with the mineral plant-food elements.

The fact that peat soils do not contain any appreciable amount

<sup>2</sup> Lava or glassy rocks are exceptions.

of mineral particles containing the necessary mineral elements explains why they are generally deficient in potassium and phosphorus.

Muck soils usually contain more potassium and phosphorus than peats, because these soils contain considerable mineral matter (Chapter II).

#### MORE ABOUT WEATHERING

**Products of Rocks Weathering.**—We have learned that the framework of mineral soils<sup>3</sup> consists of sand, silt and clay—the common products of rock weathering.

When a granite, for example, is transformed by weathering into soil, many chemical changes occur during the transformation. A residual soil from granite is not merely a powdered form of that rock, represented by a combination of sand, silt and clay. Many of the soil particles, it is true, are the same kind of mineral particles as are found in the granite; others, however, are quite different from any that ever occurred in the parent rock. The formation of the new kinds, or secondary minerals, is a result of the chemical changes, or decay. In the decay, or chemical changes, many of the complex rock minerals are split up, chemically, and their elements recombine in different ways, or unite with other elements, water and gases.

In addition, therefore, to the common products of rock weathering—sand, silt and clay, there are formed other products, among which are true clay (kaolin), carbonate of lime, and salts.

**True clay** (kaolin) is a definite, fine material originating mainly through the decay of feldspars and micas.

**Carbonate of Lime**, or lime carbonate, is lime combined with carbon dioxide gas. ( $\text{CaO} + \text{CO}_2$ ). It is formed in rock decay when the calcium (Ca) in the rock enters into a new combination with and through the action of carbon dioxide and water.

The mineral calcite is a pure form of carbonate of lime. Limestone, shells, coral, marble, dried lime mortar, air-slaked lime and marl are other forms of material containing lime carbonate.

**Salts.**—Among the many salts formed during the process of rock decay are:

*Chlorides.*—Common table salt is an example.

*Sulfates.*—Glauber's salt is an example.

---

<sup>3</sup> Soils made up of materials derived from rocks are commonly referred to as "mineral soils."

*Carbonates.*—Such as washing soda.

*Phosphates.*—As lime phosphate.

**From Granite Into Soil.**—A residual soil resulting from the weathering of a granite is usually a sandy loam or loam. The transformation of granite into soil is illustrated and summarized in the following diagram:

*From Rock into Soil*

The rock		Products of rock weathering	Resulting soil (classes)
Mineral composition	Chemical composition of the rock minerals		
Granite	Quartz	Sand, silt, clay * True clay Carbonate of lime Salts	Sandy loam or loam
	Feldspars		
	Micas		
	Hornblende		
	Pyrite		
	Si, O		
	Al, Si, Na, Ca, K, O		
	Al, Si, Na, Ca, Mg, Fe, K, O		
	Al, Si, Na, Ca, Mg, Fe, O		
	Ca, P, O		
	Fe, S		

\* Sand, silt and clay particles are mainly the products of the breaking up of rocks, while true clay, carbonate of lime and salts are products of rock decay.

**Soils From Other Rocks.**—Sandstone usually gives rise to sand or sandy soils; shale and slate to heavy clays, and limestone to silt loams and clay loams.

THE EFFECT OF CLIMATE

**Soils in Humid Climates Are Leached.**—In humid<sup>4</sup> climates the heavy rainfall causes much soil to be washed away and carried into the ocean. Sand, silt and clay are not the only materials carried into the sea—carbonate of lime and salts are also thus carried.

In a humid region much of the rainfall sinks into the ground, and as the water passes down through the soil it dissolves carbonate of lime and salts and carries them in solution until it comes to the surface in the form of springs; thence into rivers, and finally into the sea. All drainage waters, therefore, carry to the sea, carbonate of lime and salts in solution and sediments.

<sup>4</sup> When a region has an average annual rainfall of more than 30 inches it is regarded as having a humid climate. A region having an average annual rainfall of between 20 and 30 inches the climate is commonly referred to as sub-humid.

**What Becomes of the Materials Carried Into the Sea.**—The sand settles out near the shore, and in time becomes sandstone (Fig. 17).

The clay settles to the bottom farther out and finally turns to shale.

The salts remaining in solution become the "salt of the sea."

**Shells.**—The carbonate of lime is taken out of solution in the ocean water by myriads of tiny shell animals, whose shells sink to the ocean floor when they die. Coral animals, certain water plants and bacteria also cause carbonate of lime to be deposited. Usually, however, on the sea bottom beyond the accumulations

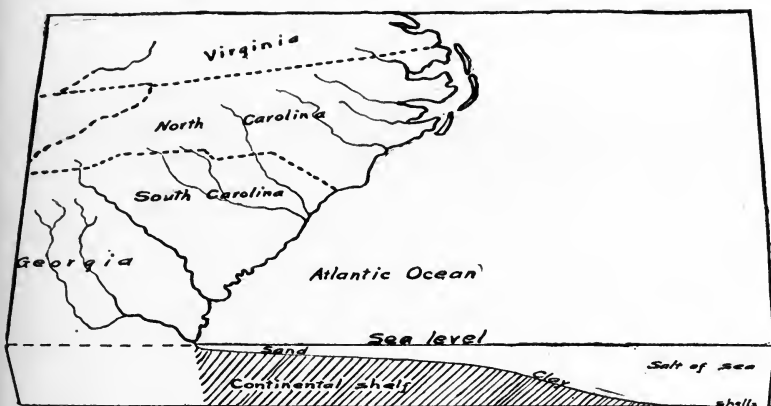

FIG. 17.—The ocean receives all the materials washed from the continents. The sand settles out of the river waters near shore, and the clay is carried farther out. The salts make the sea-water salty. The dissolved carbonate of lime is taken out of solution by tiny shell animals.

of sand and mud there are deposited shells and particles of carbonate of lime which in time turn into limestone. As a general rule, whenever limestone, sandstone or shale is found, there at one time existed a sea or lake.

The mud and sand, which are the impurities of limestone, constitute the soil-forming material when limestone weathers.

**Alkali Soils.**—Soils in regions of little or no rainfall are not leached as they are in humid or sub-humid climates. The salts formed through weathering processes, therefore, accumulate in these soils. In places the soils are so salty that cultivated plants cannot grow in them (Fig. 18). Such soils are called "alkali soils." Salty crusts commonly form on their surfaces. When

these crusts are white the name "white alkali" is used, and "black alkali" when the crusts are brown or black. "Black alkali" dissolves organic matter; hence the black crusts.

**Alkali Spots.**—In sub-humid and humid climates small areas of alkali soils may be found varying in extent from a few square rods to several acres. These areas are usually depressions or areas kept wet by seepage water. In either case there has been an accumulation of salts in these areas, the quantity is usually not sufficient to prevent entirely the growth of crops; though in some cases much injury does result.

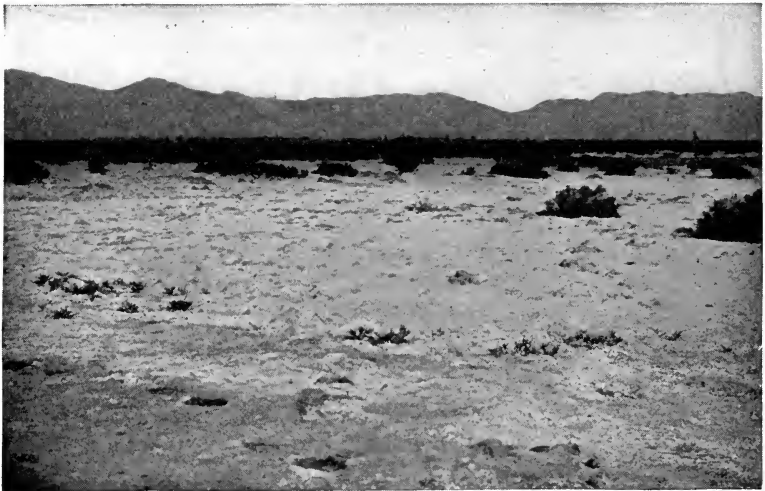

FIG. 18.—An alkali area in Western United States. Alkali soils like these do not form in humid regions, because the salts which are formed as a result of rock weathering are dissolved and carried away. (U. S. Dept. of Agriculture.)

**Other Effects of Climate.**—Soils in arid<sup>5</sup> and semi-arid climates are usually coarser textured and generally lighter in color than those of humid regions.

Arid soils are deep and uniform with but little difference in texture between soil and subsoil; while those of humid or sub-humid regions are generally of fine texture and have subsoils which contain more clay than their surface soils.

---

<sup>5</sup> Sections receiving less than 10 inches of rainfall annually are designated "arid," and "semi-arid" when the annual rainfall is between 10 and 20 inches.

In cool, humid climates, organic matter decays slowly, hence soils in such regions are generally well supplied with organic matter.

In warm, humid climates, vegetable matter in soils decays rapidly, hence the soils are usually low in organic matter. This accounts in part for the many red soils found in the South and the Tropics.

**Leached and Sour Soils.**—Soils in humid regions are generally well leached of their soluble salts. Moreover, many of them, especially the upland soils, have had the carbonate of lime so completely leached out of them that they have developed a condition generally referred to as "acidity." Soils which lack carbonate of lime are thus commonly termed "sour" or "acid."

**Illustration Material for Lessons.**—A few hand specimens of igneous, sedimentary and metamorphic rocks. (Include a sample of lava rock.) Specimens of the common rock-forming minerals. A sample of kaolin (true clay). Limestone and other natural carbonates.

If possible show samples representing different stages in the formation of soil from an igneous rock; from a sandstone; shale; and from a limestone.

A sample of an alkali soil and of a red soil commonly found in the South.

**Demonstrations.**—*Material Needed.*—A tablespoonful each of common salt and sodium carbonate; 4 tumblers; and about two-thirds of a cupful of a black soil.

**To Make Clear the Meaning of "White" and "Black" Alkali.**—*Procedure.*—Place about a handful of black soil in each of two tumblers. Fill one about half full of a strong solution of common salt (a white alkali) and the other about half full of a strong solution of sodium carbonate (black alkali). Stir the contents of each tumbler and let stand at least twelve hours. Strain the liquid into two other tumblers and note difference in color. (Show the class samples of the two salts.)

*Questions.*—(a) Which salt dissolves organic matter and which does not?

(b) What would be the color of the drainage water in a section of "black" alkali? In an area of "white" alkali?

(c) Why is the one salt called "white" and the other "black" alkali since both salts are white in color?

(d) Where are alkali soils found? Why?

**Laboratory Exercises.**—*Materials Needed.*—Specimens of common rock-forming minerals—feldspar, hornblende, quartz, white and black mica, calcite, gypsum, apatite, pyrite, etc.; specimens of common rocks, such as granite, trap rock, schist, shale, slate, limestone, marble, sandstone and quartzite.

**To Learn to Recognize the Common Rock-forming Minerals.**—*Procedure.*—Examine carefully the samples of rock-forming minerals provided for study.

Record observations in tabular form with headings as follows: Name of mineral, color, essential plant-food element it contains, plains in which mineral can be split (plains of cleavage), common end product in weathering, and relative hardness.

The relative degree of hardness can be determined by scratching each with the other. (See Rocks and Rock Minerals—Pirsson.)

*Questions.*—(a) Which are the two most common rock-forming minerals?

(b) Suppose a sand (soil) contains many sand particles of apatite. What of its phosphorus supply?

(c) A muck contains much silt and clay. What of its supply of mineral plant-food elements?

(d) Suppose the mineral matter in a muck is all quartz sand. Would its supply of phosphorus and potassium be the same as that of (c)? Why?

**To Learn to Recognize the Common Rocks.**—*Procedure.*—Examine with hand lens the different rock specimens provided. Record observations in tabular form—headings as follows: Rock group, name of rock, color, texture, structure (dense, fine grained, granular, or laminated), and important minerals of which composed.

*Questions.*—(a) What kinds of soil form the following rocks—granite, sandstone, limestone, and shale?

(b) What forms the soil in the weathering of a limestone?

**Field Studies.**—When practicable, field trips may be made for studying the rock formations of the community. Note relation between the prevailing rocks and the kinds of soil. Note also whether the areas of soil visited are of residual or transported formation.

### QUESTIONS

1. Name the three large groups or classes of rocks. How do these three groups differ from each other as regards origin? Name some of the common rocks belonging to each group.
2. Tell of the changes that rock undergoes.
3. What is a rock?
4. Name some of the common rock-forming minerals.
5. What is the source of the important mineral elements required by plants?
6. Why are some sandy soils poor in mineral plant-food elements?
7. Why are peat soils generally deficient in potassium and phosphorus?
8. Do muck soils contain more or less mineral elements than peat? Explain.
9. Name the products of rock weathering.
10. Distinguish between clay and true clay.
11. What is carbonate of lime? Name some materials containing much lime carbonate.
12. What kinds of soils are formed from granite? From sandstone? From shale? From limestone?
13. Why is the water of the sea salty?
14. Explain how sandstone, shale and limestone are formed.
15. How can a soil form from a limestone?
16. What are alkali soils? Alkali spots?
17. Name other differences in soils of arid and humid regions.
18. In what kind of a climate are acid soils likely to occur? Explain.
19. Distinguish between "arid," "semi-arid," "sub-humid" and "humid" climates.
20. In which ones of these have you lived?



## CHAPTER V

### SOIL AN IMPORTANT FACTOR AFFECTING PLANT GROWTH

THE growth of plants has interested thoughtful men of all ages. Little by little knowledge concerning plant growth accumulated, and even today all is not known. Scientists will always study and investigate the growth and habits of plants. In order that a clear understanding might be gained of some of the fundamental principles of crop production, it is necessary to know a few facts concerning the growth of plants, and note in particular to what extent soils may affect this growth.

**Conditions Must be Favorable.**—It is self-evident that a plant must have favorable conditions surrounding it before it can grow to its fullest development. These conditions must be favorable from the time the seed is planted to maturity.

The life history of a plant may be conveniently divided into four periods; viz., the seed or dormant period, the germination period, the vegetative or growing period and the fruition or fruiting period. The average farm plant passes through three of these periods in contact with the soil. We shall now consider the conditions and requirements necessary to each of these three periods.

#### THE GERMINATION PERIOD

**The Germination Period a Critical One.**—Many poor crops are to be explained in no other way than that the conditions during the time of germination were not favorable. Frequently when the conditions are too unfavorable the seeds become moldy and fail to germinate.

**Life in a Planted Seed Strives for Existence.**—When a seed is planted in the soil it is placed in a medium teeming with bacteria and fungi which would feed on the seed if no resistance were offered by it. Thus, as soon as a seed is placed in the ground there begins at once a struggle for existence on the part of the life in the seed against these bacteria and fungi. When conditions are favorable for the seed, it wins and sends out its roots and stem; if unfavorable, the soil organisms win and cause the seed to decay. How very necessary it is, therefore, that the conditions be favorable during germination.

**Requirements and Conditions for Germination.**—For a most vigorous germination seeds require (a) a favorable moisture supply in the soil; (b) sufficient air for oxygen; (c) favorable temperature, and (d) good tilth. It is to be noted that a germinating seed requires no plant-food elements from the soil or carbon dioxide from the air. It does not need them, since nature has surrounded the germ in the seed with a storehouse of food. As soon as the dormant life quickens, this store of food is drawn upon to nourish it. Water and oxygen are required for the same reason that animals require them; viz., for life processes. And warmth is just as essential in promoting these life processes in a germinating seed as it is in an animal body.

Just as some animals can tolerate lower temperatures than others, so it is with germinating seeds. Farmers in different sections of the country learn by experience when it is the best time to plant various seeds to meet favorable temperature conditions. No farmer in a temperate zone would think of planting beans and corn as the first crops in early spring. Again, corn will rot under temperature conditions that will permit germination of winter wheat and rye.

When lands are wet and cold, a farmer can help in a large measure to create more favorable temperature conditions in the soil by draining such lands.

The supply of air and moisture and the temperature conditions for the planted seed are influenced in a large degree by the physical condition of the soil or seed bed. In this connection much is said and written concerning tilth.

**Tilth Defined.**—Tilth refers to the physical condition of the seed bed with respect to mellowness and firmness, indicating whether or not the soil is capable of favoring germination or promoting plant growth.

*Good Tilth.*—When a soil has a certain degree of mellowness and firmness favorable to seed germination and plant growth, it is said to have good tilth; for example, a loamy soil having a fair degree of firmness.

*Poor Tilth.*—A soil is in poor tilth when it is too loose, very lumpy or very hard and compact. These conditions are unfavorable to germination and plant growth.

Tilth does not indicate a rich or poor soil. The poorest soil imaginable may have excellent tilth; a poor sand, for example.

The only substance a germinating seed takes from the soil is

water. Because of this, good tilth is of vital importance since firmness of the soil determines largely the ease with which the planted seed secures this moisture.

**Absorption of Water by Seeds.**—As soon as a seed is planted in moist soil it begins to absorb water, and as a consequence, it swells to its fullest extent before it germinates. Some seeds absorb more than their own weight of water. When other conditions are favorable, absorption of water determines largely the welfare of the seedling and vigor in after-growth. The factors which influence the rate of absorption are (a) contact between the seed and the soil, (b) amount of moisture in the soil, (c) temperature, and (d) salts. These factors may seem unimportant; on the contrary they have direct bearing on successful farming.

**Contact between the seed and soil** is the means whereby the moisture in the soil gets to the seed. The better the contact, therefore, the better the moisture supply for the seed, provided, of course, there is moisture in the soil. This explains in part why a firm seed bed is generally desirable. Alfalfa seed sown in a loose, ashy seed bed very often results in failure, because of the lack of good contact between the seed and the soil.

**Moisture.**—Seeds cannot germinate in dry soil. The planting of soaked seeds in dry soil invariably results in failure. The more water in the soil does not necessarily mean a more rapid absorption and hence a more rapid germination. Too much water shuts out oxygen and it also creates unfavorable temperature conditions.

**Warmth favors and cold retards absorption** of water by seeds. When water absorption is retarded germination also is retarded.

**Salts Retard the Rate of Absorption.**—Under like condition seeds will absorb moisture more slowly and hence germinate somewhat more slowly in a rich soil than in a poor one. If present in considerable amounts, salts act as poisons. Many alkali soils will not permit germination of seeds. Some salts are poisonous to plants even in small amounts. Sometimes a farmer greatly retards germination or even kills his corn seed, for example, by dropping too much fertilizing salts on the seed in the hills or drills.

#### THE VEGETATIVE OR GROWING PERIOD

**The Period of Greatest Activity.**—This is a most active period in the life history of a plant. During this period the plant carries on six distinct activities, namely:

1. It respire.
2. It transpires—moisture is given off, particularly from the leaves.
3. It takes in substances (raw materials): (a) Carbon dioxide, (b) water,<sup>1</sup> (c) salts (containing nitrogen and mineral elements).
4. It converts the raw materials into foods: (a) Protein, (b) carbohydrates, (c) fats.
5. It grows.
6. It stores foods.

**The Plant a Factory.**—As soon as the seedling establishes itself in the soil it shifts its dependence for food from that stored in the seed by its parent plant to that of its own manufacture. Thus

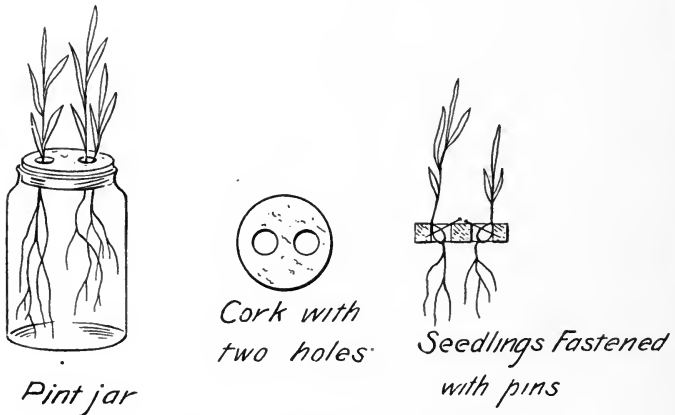

FIG. 19.—A plant culture in a fruit jar.

the plant grows into a real manufacturing establishment, most wonderful and mysterious throughout. The plant cells correspond to the departments—the leaf cells being the most important; the content of the cells, chlorophyll,<sup>2</sup> etc., represents the machinery; the raw materials taken in are carbon dioxide, water and salts (Fig. 19); the power is the energy of sunlight; and the products are foods, of which there are three classes—protein, carbohydrates and fats. The common carbohydrates are sugars and starches.

**Conditions and Requirements During Vegetative Period.**—In order that the average farm plant might carry on all its activities

<sup>1</sup> Only a comparatively small amount of the water taken in by plants is used in the manufacture of foods—most of it is transpired.

<sup>2</sup> Chlorophyll is the substance in plants that gives them their green color.

in the best possible manner, the following conditions and requirements must be met:

- (a) Sufficient moisture must be present in the soil.
- (b) The plant must have air from which to secure oxygen and carbon dioxide.
- (c) Favorable temperature must prevail.
- (d) The soil must be in good tilth.
- (e) The plant must be able to secure sufficient nitrogen and mineral elements from the soil.
- (f) The plant must have sufficient sunlight.

It is to be observed that in this period the plant demands three other requirements and conditions in addition to those required during germination; viz., carbon dioxide, plant-food elements and sunlight.

**Temperature in Relation to Crop Growth.**—The air temperature at which plants grow the best varies with different farm crops. The best for small grains is between 77 and 88 degrees F.; for cucumbers and melons, between 88 and 99 degrees; for corn and hemp, between 99 and 110 degrees.

The lowest air temperatures at which crops can make some growth are as follows: for small grains, between 32 and 41 degrees F.; for corn, between 41 and 51 degrees; for tobacco, between 51 and 60 degrees; and for melons and cucumbers, between 60 and 65 degrees.

**Permeable Soil Is Important (Good Tilth).**—If the soil covering a seed should become hard and very compact, the stem may not, or may with difficulty, succeed in breaking through. If the soil around and below it also becomes too hard and compact, the roots are checked in their development—a stunted plant is the result.

If, on the other hand, the soil is in a condition to permit the stem to push itself through to the surface with ease, and the roots to penetrate the soil without hindrance, the seedling soon establishes itself as a vigorous plant. A permeable soil, therefore, is an important condition, not only when the plant is very small but throughout its growing period.

Much attention, therefore, should be given to the preparation of the most favorable condition that will enable a young plant to establish itself in the soil in the quickest and best possible manner. This attention is to be confined largely to the development of good tilth, or in other words, to the preparation of a good seed bed. The smaller the seed to be sown, the better the seed-bed preparation should be (Figs. 20 and 21).

**What Good Tilth Implies.**—Very often a farmer is deceived in thinking that the looser the soil or seed bed becomes through

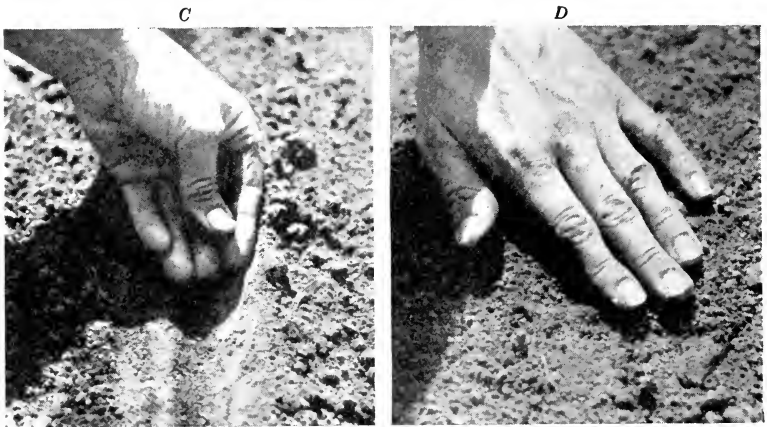

FIG. 20.—The secret in planting garden seeds properly. Place the seeds in a shallow trench made in a firm, moist seed bed, cover seeds lightly with fine, moist soil, press the soil on the seeds to secure good contact between the soil and the seeds (C), then cover with loose soil (D).

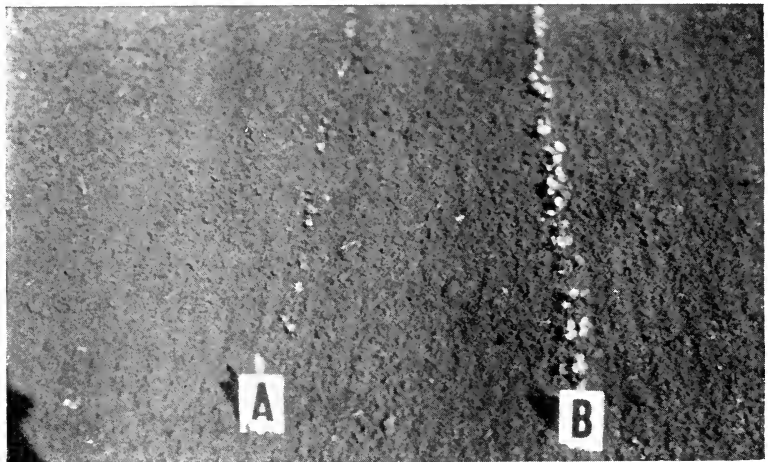

FIG. 21.—The difference it makes. Radish seeds in row A were planted loosely in moist soil, while those in row B, though planted the same time, were pressed in close contact with the moist soil, as in Fig. 20. This principle in seed-planting applies generally.

plowing and harrowing, the more excellent the tilth or seed bed. Good tilth does not imply just looseness or mellowness of the seed bed—it means a certain degree of firmness or compactness as well.

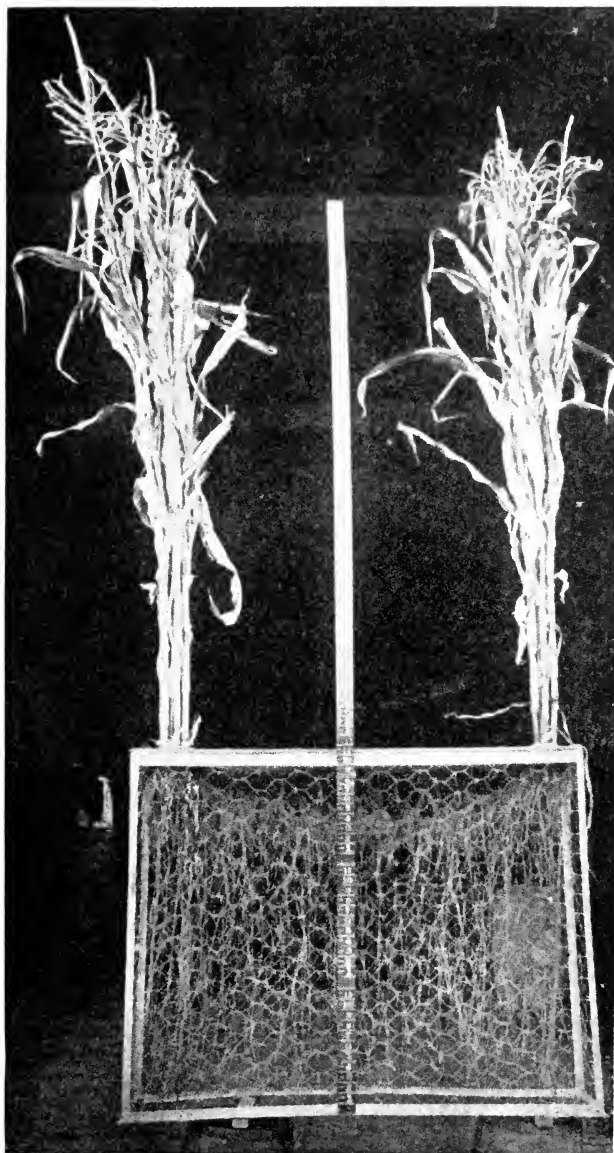

FIG. 22.—The development and distribution of corn roots in permeable soil under field conditions. (King.)

The full meaning of good tilth and its importance as regards the seed and the young plant may be gained by studying the following brief outline.

Good tilth implies	<ol style="list-style-type: none"> <li>1. Mellowness of seed bed to permit of</li> <li>2. Firmness of seed bed to secure good contact (Fig. 20)</li> </ol>	<ol style="list-style-type: none"> <li>a. Entrance of air.</li> <li>b. Stem penetration.</li> <li>c. Root penetration.</li> </ol>
		<ol style="list-style-type: none"> <li>a. Between soil particles.</li> <li>b. Between seed and soil.</li> <li>c. Between roots and soil.</li> </ol>

Whenever a seed bed is too loose, therefore, it should be made firm even before planting, by the use of a roller, so that there will be good contact between the soil particles, between the seed and the soil when the seed is planted, and later on between the roots and the soil. The soil should be firm enough to make this good contact possible, yet not so compact as to prevent the entrance of air and the easy penetration of the stem and roots (Figs. 22 and 23).

**Factors Affecting the Development of Good Tilth.**—The development of good tilth through cultivation depends largely on the texture, structure, and moisture content of the soil. Heavy soils usually require careful management to secure good tilth. It is not difficult to develop a good seed bed on sandy and loamy soils, and on soils having a crummy or granular structure.

A hard and lumpy or heavy clay if plowed in the fall will develop good tilth of itself as a result of the freezing and thawing during winter and early spring.

All soils work up much better when they contain a proper amount of moisture. Plowing or cultivating a heavy soil when too wet invariably results in poor tilth, in that the soil becomes hard and lumpy.

**Plant-food Elements.**—The so-called “raw materials” taken in by plants contain the essential elements which enter into the composition of the foods made by them, hence the term “plant-food elements.”

**Availability of Plant-food Elements.**—Nitrogen and the mineral elements enter the plants through their roots in the form of compounds or salts in solution.<sup>3</sup> These elements must be in the form of soluble compounds, or in liquid form, before they can become available to the plants. In this respect we speak of “availability” of the plant-food elements.

<sup>3</sup> Water enters a plant through its roots by a process called “osmosis.” The entrance of salts in solution may be termed “diffusion.”



When a soil has an ample supply of the necessary elements in soluble form or in a condition which may be easily converted into soluble form when needed for the production of a large crop, that soil is described as having sufficient "available" plant-food elements for a good yield.

The fact that crop production depends in a large measure upon the availability of the plant-food elements in the soil makes it necessary that farmers understand the conditions whereby soils may give up these elements in the amounts demanded by good crops. These conditions and principles are discussed in later chapters.

**Function of the Plant-food Elements.**—It is of interest to note briefly the functions of the elements required by crops.

Carbon is used in the making of carbohydrates, fats and protein.

Nitrogen is used in the making of protein.

Phosphorus is of much importance in the "filling out" and development of the grain, often hastening maturity. It is also used in the making of protein. Sufficient available phosphorus causes young plants to develop good, strong root systems.

Potassium is much needed by plants to aid in starch and protein formation. Such crops as corn, sugar beets, potatoes, alfalfa and clover, therefore, require large amounts of this element.

Calcium seems to be used largely in leaf and stalk development. It is also regarded as a protective agent, in that it prevents harmful effects of acids formed within the cells.



FIG. 23.—An argument in favor of a deep seed bed. The desirable type of sugar beet. (U. S. D. A.)

Sulfur enters into the composition of protein.

Magnesium seems particularly necessary for leaf development.

Iron is necessary for chlorophyll formation.

#### THE FRUITION PERIOD

During this period the plant arrives at its maturity. It reaches its object of life; viz., the production of fruit or seed to propagate itself. During this period grains "fill" and harden, and fruits mature and ripen. This is not a period of food manufacture, but rather of translocation of foods from the stems and leaves to the fruit or seed. Air, moisture and favorable temperature are the necessary requirements.

**Demonstrations.**—*Material Needed* (not including demonstration No. 8).—About 12 ounces of corn (seed); a few wheat kernels, and a few clover, cucumber, oat and bean seeds; 6 tumblers; 1 balance; a tablespoonful or more of salt; 1 quart of quartz sand; 6 one-gallon crocks; 18 quarts of loam or silt loam; and 10 quarts each of rich garden soil and a poor soil of the same class.

**To Show That Seeds Absorb Much Water Before They Germinate.**—*Procedure.*—Weigh out 50 grams or 2 ounces of either corn, beans or small grain and soak in water for 24 hours. Then wipe off the adhering water and weigh again. Determine the per cent of water absorbed. (Use weight of dry seeds as basis.)

**To Show That Temperature Affects the Rate at Which Water is Absorbed by Dry Seeds.**—*Procedure.*—Weigh out two lots of seed of 50 grams or 2 ounces each. Soak one lot in warm water and the other lot in cold water for about two hours. Wipe off the adhering water, weigh, and determine the per cent of water absorbed.

**To Show that Salt Retards the Rate of Absorption of Water by Seeds.**—*Procedure.*—Place one 2-ounce lot of seed corn in fresh tap water, and another lot in a strong salt solution. Keep all at the same temperature for several hours. Then wipe the seeds and compare weights.

**To Show That no Added or Outside Plant-food Elements are Needed for Germination.**—*Procedure.*—Plant large, medium and small seeds (corn, wheat, clover) in pure quartz sand. Keep moist with pure water. Keep in favorable temperature, light, etc., and note time in which plants appear. Continue observations until plants die.

*Questions.*—(a) Name the essential conditions for germination.

(b) Why are not plant-food elements from outside sources needed for germination?

(c) Why do the lower leaves dry up first?

(d) Will the dry material of the dead plants (roots and all) weigh more or less than that of the seeds? Why?

(e) Will the amount of ash be greater or less? Why?

**To Show the Effect of Temperature on Plant Growth.**—*Procedure.*—Plant either winter wheat or oats and cucumber seeds in each of two one-gallon crocks filled with loam or silt loam. Place both jars in a favorable place. Water. When the plants are well started, place one crock in a well-lighted place having a temperature between 35° and 40° F. and leave the other jar in the greenhouse under favorable temperature conditions. Observe results after 10 days or two weeks.

**To Make Clear the Meaning of "Carbohydrate."**—*Procedure.*—Put a tablespoonful of sugar into a tumbler; add a little water to make a thick syrup (keep cool), then add about two tablespoonfuls of sulfuric acid. Note results (Fig. 24).

*Questions.*—(a) Where did the carbon come from?

(b) How did the plant get it?

(c) Why is not sugar black since it contains so much carbon?

(d) Of what is a diamond made?

(e) What is the difference between a diamond and a piece of charcoal?

**To Show that a Farmer Must Observe Temperature Conditions When Planting Different Seeds.**—*Procedure.*—Proceed as in demonstration No. 5, and plant a few seeds of wheat, beans and cucumbers in each crock. Place one crock in the greenhouse and the other in a well-lighted place having a tem-

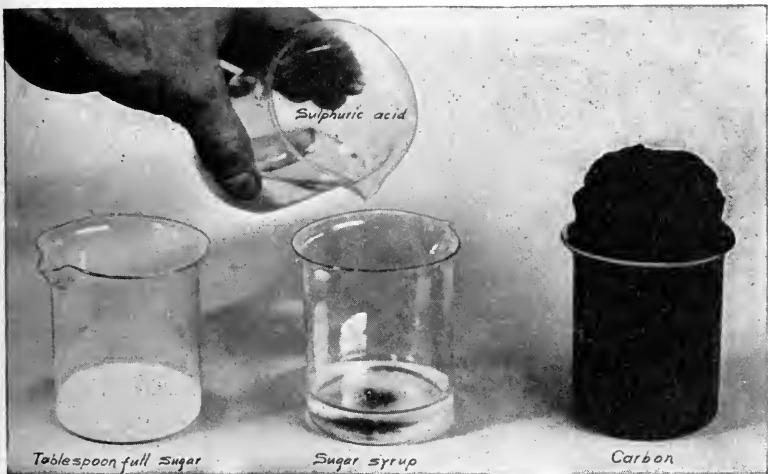

FIG. 24.—What happens when the chemically-combined water is withdrawn from sugar? The carbon in the sugar is set free. Sugar is a carbohydrate = (carbon + water) = 12 atoms of carbon (C) combined with 11 atoms of water ( $H_2O$ ). In this case the water was withdrawn from the sugar by sulphuric acid.

perature between  $35^{\circ}$  and  $40^{\circ}$  F. Observe results regarding germination and growth.

*Question.*—Construct a table showing the best air temperature at which some of the common farm crops grow the best, and the lowest temperature at which crops can make some growth.

**To Compare the Rate of Germination of Corn in a Rich and a Poor Soil.**—*Procedure.*—Procure about four quarts of a rich greenhouse soil and the same amount and kind of poor soil. Allow both soils to warm to the same temperature. Moisten both and place in two one-gallon crocks. In each plant about five kernels of corn. Place both in a favorable place, water when necessary, and observe which plants appear first. Continue observations until after four or five weeks.

*Questions.*—(a) Give reason for the difference in germination and early growth.

(b) Give reason for the difference in growth after four or five weeks. (Consult text.)

**To Demonstrate the Need of Nitrogen and the Six Essential Mineral Elements in Plant Growth.**—*Procedure.*—Place 50 kernels each of wheat and oats between moist blotters, and germinate. When the seedlings are well started transfer the best ones to culture solutions (Fig. 19). By means of pins fasten at least 3 of each kind of seedlings in each cork. Start four cultures, as follows:

(1) Distilled water, (2) full nutrient solution, (3) nutrient solution without phosphorus, (4) a culture without iron. Place in favorable place and observe growth.

Prepare full nutrient solution as follows:

Potassium acid phosphate . . . . .	8 grams in $\frac{1}{2}$ liter distilled water.
Calcium nitrate . . . . .	6 grams in $\frac{1}{2}$ liter distilled water.
Magnesium sulfate . . . . .	15 grams in $\frac{1}{2}$ liter distilled water.
Ferric chloride . . . . .	0.05 grams in $\frac{1}{2}$ liter distilled water.

For use take 50 c.c. of each of the first three solutions and 4 c.c. of the ferric chloride solution, mix, and dilute to 500 c.c. with distilled water.

For nutrient solution without phosphorus use 10 grams of potassium chloride instead of potassium acid phosphate.

For nutrient solution without iron omit the ferric chloride solution.

Cover each jar with brown paper. Keep jars full by using distilled water. Renew culture solution if plants are allowed to grow a long time. Observe the character of growth and root development.

**Laboratory Exercises.**—*Material Needed.*—A handful each of corn, beans, oats and wheat seeds; 2 tumblers; 18 one-gallon crocks; a small amount of tincture of iodine; one mortar and pestle; 8 quarts dry fine sand; 8 quarts moist fine sand; 8 quarts wet fine sand; 4 quarts dry silt loam; 4 quarts moist silt loam; 4 quarts wet silt loam; 4 quarts black sandy loam; 4 quarts light colored sandy loam; a small amount pulverized muck and lime; 12 thermometers.

**To Demonstrate That Oxygen is Necessary for Germination.**—*Procedure.*  
—(a) Place some corn, beans and wheat seeds in two tumblers of water. Change the water in one tumbler each day, but do not change the water in the other. (b) Plant some corn, wheat and bean seeds in each of two one-gallon crocks. Maintain favorable moisture conditions in one, and keep the other soil saturated and flooded with water. Record results.

*Questions.*—(a) Why cannot seeds germinate in stagnant water?

(b) Why do corn and beans often rot in wet, cold soils?

(c) Why is oxygen necessary for germination?

**To Demonstrate the Importance of Good Contact Between the Soil and the Planted Seed.**—*Procedure.*—Fill a two-gallon crock with a loam and tamp so as to make a good, firm seed bed. Make two shallow furrows with a stick and sow radish seeds in each. Cover seeds in one furrow with moist soil, press soil down on seed, then cover with loose dirt. Cover the seeds in the second furrow with moist soil but do not press the soil on the seed. (Before preparing the seed bed see that the soil is moist or contains a favorable moisture supply, Figs. 20 and 21.) Place the crock in a favorable place—do not water. Observe results.

*Questions.*—(a) Why is it necessary to have good contact between the seed and soil?

(b) What is the meaning of tilth?

(c) What is good tilth?

**To Study the Effect Produced When a Clay or a Heavy Clay Loam is Worked When Very Wet.**—*Procedure.*—Place a cupful of clay or a heavy clay loam upon a pie tin or saucer. Add sufficient water to form thick mud. Mold the mud into a ball and allow it to dry out in the sun. Repeat, using a sand. Note results. (Save hard clay ball for next exercise.)

**Questions.**—(a) What is the result when a heavy soil is plowed too wet?

(b) Why is clay called plastic?

(c) Why does not the sand ball harden like the clay?

(d) What has happened to make the clay ball become so hard on drying (Look up "puddled soil" in index.)

**To Study the Effect of Freezing and Thawing on a Puddled Soil.**—*Procedure.*—Thoroughly moisten the hard clay ball obtained in the previous exercise, and freeze it if the weather is cold, or use a freezing mixture. Place the frozen ball in the sun to thaw out and dry. Note results.

**Questions.**—Explain why it is good to plow a hard, lumpy soil in the fall.

**To Determine the Effect of Salt When it is in Contact with Planted Seeds.**—*Procedure.*—Fill a one-gallon crock with moist loam and plant 4 kernels each of corn and oats. On the first pair of seeds (corn and oat) do not put any salt; on the second one pinch; on the third two pinches; and on the fourth three pinches of salt. Cover with soil and observe results. Water when necessary.

**Questions.**—(a) In what ways does salt affect a germinating seed?

(b) Of what importance is this fact to farmers? (See text.)

**To Note the Effect on a Plant of Growing it in Darkness.**—*Procedure.*—Plant corn and beans in each of two one-gallon crocks. Water both, and keep at the same temperature. Keep one in the greenhouse and the other in a dark room. Allow the plants to grow for 2 to 3 weeks and then test the leaves for starch with tincture of iodine. (A blue color indicates the presence of starch.)

**Questions.**—(a) What did the plants in darkness live on?

(b) Why is there no starch in the leaves of the plants grown in darkness?

(c) Why are the plants grown in the darkness white?

(d) What is necessary in the manufacture of starch by the plant?

(e) Why is it difficult to obtain a test for starch in the green leaves early in the morning?

**To Note the Effect of Color, Water and Soil Texture on the Temperature of Soils.**—This exercise may be set up and students observe results.

*Procedure.*—Fill 12 one-gallon crocks within one-half inch of the top as indicated below. Pack the soils uniformly and carefully, and have crocks filled to the same mark. This is to be done one day. Set the prepared crocks where the sun will not strike them and where all will remain at the same temperature till the next day. Avoid steam pipes.

No. 1.—Fill with water.

No. 2.—Dry fine sand.

No. 3.—Moist fine sand.

No. 4.—Dry fine sand with  $\frac{1}{4}$  inch of ground muck on surface.

No. 5.—Dry fine sand with  $\frac{1}{4}$  inch of powdered slaked lime on surface.

No. 6.—Dry silt loam.

No. 7.—Moist silt loam.

No. 8.—Wet silt loam.

No. 9.—Black sandy loam (dry).

No. 10.—Light colored sandy loam (dry).

No. 11.—Moist fine sand with surface at right angles to sun.

No. 12.—Moist fine sand with surface slanting away from sun.

Put thermometers which were previously tested for uniformity in the crocks so that the bulbs are  $1\frac{1}{2}$  to 2 inches below the surface. Do not have the soil cover them above the  $20^{\circ}$  mark. Put all the thermometers in at the same time and read them as soon as they have had time to register. Record results. Place the crocks in the sun with one side on a strip of board to incline the surfaces somewhat toward the sun. (Remember that 11 and 12 have special treatment.) Read the thermometers every 20 minutes for 2 hours. Record results in tabular form as follows:

*Temperature*

Treatment	Start	20 min.	40 min.	60 min.	80 min.	100 min.	120 min.
Water only . . . . . etc. . . . .							

*Questions.*—(a) Why does dry soil heat quicker than wet soil?

(b) Why does sand heat quicker than silt loam?

(c) Why are northern slopes preferable for orchards?

(d) Give four reasons why a water-logged soil will not warm up so readily as a well-drained soil.

(e) How can a farmer aid a low, wet field to warm up quicker in the spring?

(f) Name the factors that influence soil temperature.

**Field Studies.**—Become familiar with the meaning of tilth and seed bed by observing soil condition in several selected fields.

Note the temperature of certain well-drained soils, sandy soils, heavy soils, peat and muck, poorly drained soils, and soil on south and north slopes.

## QUESTIONS

1. Name the periods in the life history of a plant. Through what periods does it pass in contact with the soil?
2. Why is it important to have favorable conditions surrounding a planted seed? What are these favorable conditions?
3. Can a farmer ever help to create more favorable temperature conditions for seed germination and plant growth? How?
4. What is meant by tilth? Good tilth? Poor tilth? Illustrate.
5. Does good tilth imply a rich soil?
6. What is the relation between the absorption of water by seeds and germination?
7. Name factors influencing rate of water absorption by seeds. Discuss each.
8. Which is the period of greatest activity in the life history of a plant? Name these activities.
9. How may a plant be compared to a factory?
10. Name the requirements and conditions necessary during the growing period of a plant. How do these requirements compare with those of the germinating period?
11. Discuss temperature in relation to crop growth.
12. What is the importance of permeable soil in relation to the growth and vigor of young plants?
13. What is the importance of good tilth as regards the seed and the young plant?
14. Explain how texture, structure and moisture content of soils affect the development of good tilth through cultivation.
15. Why is it good to plow a hard, lumpy soil or a heavy clay in the fall?
16. What is meant by availability of the plant-food elements?
17. What becomes of the carbon taken in by plants? Of the nitrogen? Of the sulfur?
18. What seems to be the function of calcium in plants? Of magnesium? Why do plants need iron?
19. Give three reasons why it is important to have a good supply of available phosphorus in the soil.
20. Explain why corn, sugar beets and potatoes require much potassium. Do alfalfa and clover crops need much potassium? Why?
21. What are the requirements of a plant in the fruition period?
22. For summary of Chapter V see the table of contents.

## CHAPTER VI

### CROPS AS FEEDERS ON THE PLANT-FOOD ELEMENTS IN THE SOIL

THE elements most commonly studied in relation to crop production are nitrogen, phosphorus, potassium and calcium. These four will receive careful consideration in further study. All crops are feeders on these important elements and hence they remove from the soil varying amounts. In this respect a soil actually gives up a part of itself in producing crops.

**Soil Particles Are Not Plant Foods.**—It was thought at one time that crops consumed or digested soil grains, especially the finest ones.<sup>1</sup> This thinking led some of the very early agricultural writers to advocate the reduction of soil to very fine dust so as to enable plants to obtain the amount of soil sufficient for good yields. It was an idea similar to this, no doubt, that gave to the word "manure" its original meanings, viz., "to till" and "to work by hand."

**Forms in Which Plants Secure Their Elements.**—We have learned that plants secure the elements they require in the form of carbon dioxide, water and soluble salts. The soluble salts are derived largely through the decay of organic matter and the mineral soil particles.

**Amount of Elements Removed From Soil by Crops.**—The accompanying table gives the amounts of nitrogen, phosphorus, potassium and calcium removed by the more common crops. These amounts are based on crop yields that may be secured on a productive soil. The amounts contained in the grain, stalk and straw are given where called for. These figures represent the averages of many hundreds of crop analyses made in many laboratories.

It is to be observed that it requires approximately a pound of nitrogen to grow a bushel of oats or barley, and about one and one-half pounds per bushel of corn (Fig. 25.)

A fifteen-bushel wheat crop would take from the soil about one-half the amounts removed by a thirty-bushel crop. The draft made on the elements by a seventy-eight-bushel corn crop would

---

<sup>1</sup> Jethro Tull's theory—England, 1730.

*Plant Food Elements Removed by Harvested Crops*

(Pounds per acre per year)

Crops	Yield per acre	Nitrogen (N)	Phosphorus (P)	Potassium (K)	Calcium (Ca)
Alfalfa hay . . . . .	5 tons	(238)	23.6	185.0	185.0
Barley, grain . . . . .	40 bu.	35.3	7.1	11.8	0.8
Barley, straw . . . . .	1 ton	11.2	1.6	19.9	4.6
Barley, total crop . . . . .		46.5	8.7	31.7	5.4
Beet, sugar (roots) . . . . .	15 tons	78.0	10.5	79.5	8.0
Blue grass (Kentucky) . . . . .	2 tons	53.2	9.4	70.0	12.0
Buckwheat, grain . . . . .	30 bu.	21.8	5.5	7.3	0.3
Buckwheat, straw . . . . .	$\frac{3}{4}$ ton	12.5	0.85	14.1	10.3
Buckwheat, total crop . . . . .		34.3	6.35	21.4	10.6
Cabbage (heads) . . . . .	15 tons	105.0	9.2	72.0	36.0
Clover hay, medium red . . . . .	2 tons	(82.0)	6.8	54.0	61.6
Clover hay, alsike . . . . .	2 tons	(80.0)	12.0	57.5	39.2
Clover hay, Japan . . . . .	2 tons	(77.6)	18.0	68.8	40.5
Corn, grain . . . . .	65 bu.	59.0	9.1	12.0	0.7
Corn, stover* . . . . .	$1\frac{3}{4}$ tons	33.0	6.8	40.0	12.2
Corn, cob . . . . .	900 lbs.	3.0	0.3	4.0	0.1
Corn, total crop . . . . .		95.0	16.2	56.0	13.0
Corn (for silage) . . . . .	12 tons	81.6	16.7	87.5	14.0
Cotton, lint . . . . .	500 lbs.	1.5	0.3	2.5	0.6
Cotton, seed . . . . .	1000 lbs.	31.5	5.7	9.5	1.8
Cotton, total crop . . . . .		33.0	6.0	12.0	2.4
Cowpeas hay . . . . .	2 tons	(124.0)	16.4	137.0	36.0
Flax, grain . . . . .	15 bu.	30.4	5.5	6.6	2.0
Flax, straw . . . . .	0.9 ton	20.6	1.5	15.6	9.3
Flax, total crop . . . . .		51.0	7.0	22.2	11.3
Hemp (dry stalks) . . . . .	3 tons	20.0	4.0	44.0	30.0
Millet hay (common) . . . . .	3 tons	80.0	9.5	107.0	16.2
Oats, grain . . . . .	50 bu.	31.7	5.6	7.4	1.1
Oats, straw . . . . .	$1\frac{1}{4}$ tons	14.5	2.4	31.1	7.5
Oats, total crop . . . . .		46.2	8.0	38.5	8.6
Onion (bulbs only) . . . . .	500 bu.	60.0	11.0	52.0	31.0
Peas, grain . . . . .	20 bu.	44.0	4.5	10.1	2.0
Peas, straw . . . . .	$1\frac{1}{2}$ tons	30.0	2.5	26.4	42.3
Peas, total crop . . . . .		(74.0)	7.0	36.5	44.3

\* When corn is shocked in the field weathering causes a loss of elements, especially potassium, from the stalk and leaves.



Crops	Yield per acre	Nitrogen (N)	Phosphorus (P)	Potassium (K)	Calcium (Ca)
Peas, green, total crop....	7.5 tons	(85)	7.2	35.0	55.0
Potatoes, Irish (tubers)...	200 bu.	42.0	6.3	53.0	2.4
Potatoes, sweet (tubers)...	200 bu.	35.0	5.0	51.0	.....
Rye, grain.....	25 bu.	26.5	4.5	6.6	0.5
Rye, straw.....	1¼ tons	12.0	3.0	16.4	5.5
Rye, total crop.....	.....	38.5	7.5	23.0	6.0
Soybeans, grain.....	20 bu.	70.0	7.1	24.6	2.2
Soybeans, straw.....	1 ton	35.0	5.4	32.7	31.3
Soybeans, total crop.....	.....	(105)	12.5	57.3	33.5
Timothy hay.....	2 tons	39.0	5.4	45.0	10.0
Tobacco, leaves*.....	1500 lbs.	41.0	2.7	59.0	41.0
Tobacco, stalk.....	1250 lbs.	26.0	2.5	33.0	6.8
Tobacco, total crop.....	.....	67.0	5.2	92.0	47.8
Turnips (roots only).....	15 tons	60.0	13.0	72.0	15.0
Wheat, grain.....	30 bu.	35.6	6.8	7.9	0.7
Wheat, straw.....	1.6 tons	16.0	1.8	19.6	4.3
Wheat, total crop.....	.....	51.6	8.6	27.5	5.0

\* Leaves and stalk containing 30 per cent moisture.

be approximately one-fifth greater than that made by a sixty-five-bushel crop. In this way we can estimate the amounts of the elements removed by various yields.

The greater the yields the heavier the draft upon the soil.

The figures in parentheses in the nitrogen column indicate the total nitrogen content of the legume crops. Much of this nitrogen is gathered from the air by means of bacteria in the nodules on their roots.

#### SOME INTERESTING AND PRACTICAL FACTS CONCERNING THE FEEDING OF CROPS

**Distribution of the Elements in Plants.**—As a rule more nitrogen is contained in the grain than in the stalk or straw. Phosphorus goes largely into the grain—the potassium and calcium into the stalk, straw and leaves. Calcium is found largely in the leaves.

**Relation Between Elements and Nutrients.**—Crops which utilize large amounts of nitrogen are rich in protein. (Compare the preceding table with the table of nutrients in the appendix.)

Crops requiring large amounts of potassium are usually rich in protein or carbohydrates.

Crops which require much calcium are rich in protein—alfalfa is a good example.

**Crops Vary in Their Needs of Plant-food Elements.**—Crops vary in their requirements of the important elements. Cabbage, sugar beets, tobacco, alfalfa and corn are some of the “heavy feeders.”



FIG. 25.—A soil actually gives up a part of itself in producing crops. All crops remove nitrogen and mineral elements from the soil.

Wheat requires more nitrogen and phosphorus per bushel than oats. It is interesting in this connection to mention that wheat stands up much better on a comparatively rich soil than oats.

It is better to grow such crops as potatoes, corn, sugar beets or cabbage on land heavily manured or rich in nitrogen than to attempt to grow oats. Under such conditions an oat crop lodges badly. It is difficult to prevent lodging of grains on some soils.

**Lodging of Grains.**—Lodging is explained on the theory that the crops do not secure nitrogen and the mineral elements in the proper proportion. A large amount of easily available nitrogen,

together with a comparatively low amount of available mineral elements in a soil invariably causes lodging of small grains. Too much nitrogen produces rank growth, much leaves and weak straw. It is not easy to overcome such conditions. It is good farm practice to try to prevent such conditions by maintaining in the soil a good supply of easily available mineral elements as well as a good nitrogen supply.

**Alfalfa a "Heavy Feeder."**—Much is said concerning alfalfa as a great soil enricher. Many believe that it takes only a small amount of the elements from the soil, and that somehow the more alfalfa is raised the richer the soil becomes in every respect. The fact is that in a year a five-ton alfalfa crop removes from the soil of one acre five and one-half pounds more phosphorus, one hundred thirty pounds more potassium and one hundred sixty-eight pounds more calcium than a sixty-five-bushel corn crop. It is not surprising, therefore, that alfalfa should require a rich soil, and that it fails on a poor soil.

It is believed by some that alfalfa draws most of the mineral elements from the deep subsoil. In deep and porous soils considerable phosphorus and potassium, no doubt, is brought up from the deep subsoil; but in a soil having a heavy, silty clay or clay subsoil beginning a few inches below the surface it is doubtful that very much available mineral element is present to be absorbed by the deep alfalfa roots. The fact remains, however, that when the seven or eight inches of surface soil is poor, alfalfa cannot be grown successfully without heavy fertilization. The reason for this is explained in the fact that most of the fibrous, feeding roots are to be found in the surface soil. The roots which penetrate the deep subsoil secure a good water supply for the alfalfa.

In one respect the growing and feeding of alfalfa on the farm does enrich the soil, viz., in nitrogen. This can be said of all legumes.

**Timothy Not a "Soil Robber."**—It is a common belief that timothy is "hard on the land." In studying the preceding table, we observe that this crop does not draw heavily upon the soil. No doubt timothy got its mean reputation in this manner: When a field no longer will grow profitable crops of grain or corn as a result of exhaustive cropping, it is seeded with timothy, because it is usually a sure crop, not easily killed out, and it may be grown several years on such land without much attention being given to it.

Because its draft upon the soil is comparatively light and since it is able, because of its well-developed root system, to draw the last trace of available elements from the soil, this crop yields from fair to good even though the soil is too poor for other crops. In time, however, even timothy will yield poorly. The sod is plowed up, and if not manured, the crops on this poor timothy sod are scant. Farmers have often observed that when a field is sown half to clover and the other half to timothy, and both sods are plowed, manured and planted to corn, the corn on the clover sod is much the better crop. Since these facts have been generally observed, it is inferred that timothy must be a "soil robber."

It is true, nevertheless, that clover is a much better crop to grow because of its higher feeding value, and because it can gather nitrogen from the air by means of bacteria that live in the nodules on its roots.

**Some Plants Have Strong Feeding Powers.**—It has been demonstrated that some crops, better than others, can secure their requirements of mineral elements from insoluble substances in the soil. Buckwheat, for example, can secure its need of phosphorus from soils low in available phosphorus better than oats, corn or millet. Perhaps this explains why buckwheat does so well on poor or exhausted soils, and why it is a good crop to grow to plow under as the first step in the improvement of such soils.

In general, a plant that can grow well on poor soil may be regarded as having a strong feeding power, while a plant that can not grow well except on a very rich soil may be regarded as having a weak feeding power.

**Barley Requires a Richer Soil Than Oats.**—When we compare the amount of the elements required by average good crops of barley and oats, we find but little difference. A soil capable of producing forty bushels of barley per acre would easily produce from sixty to sixty-five bushels of oats. In that case the oats would draw heavier upon the soil than barley. Nevertheless, it is generally recognized that a richer<sup>2</sup> soil is required to grow common barley than oats. For an explanation we must study the habits of these two crops.

Barley does not develop so extensive or deep a root system as the oat, and hence draws on less soil for its needs. It also has a weaker feeding power and it matures earlier. Thus barley

---

<sup>2</sup> A rich soil is understood to mean a soil having a good supply of available plant-food elements, as indicated by good crop growth.

must get its necessary amount of plant-food elements from less soil with less ease and in less time than oats. A richer soil, therefore, is necessary for barley to enable it to secure its requirements.

**Fertilizer Needs Best Determined by Tests.**—Since the table gives the amounts of the important plant-food elements actually contained in crops harvested, it is useful in showing the draft that harvested crops make on soils. The figures are not to be taken to indicate exactly how much and in what proportion the fertilizing elements, in the form of fertilizers, should be supplied to crops growing on any particular soil. The only sure way to determine the fertilizer needs of any crop on a particular soil is by fertilizer tests—for the following reasons:

1. The condition of the soil with respect to the “availability” of the elements is difficult to determine by chemical analyses.

2. The feeding power of certain plants may not be well understood.

3. Some plants vary in their chemical composition and hence in their requirements of some of the elements at different stages in their growth. Corn and potatoes, for example, contain the most potassium when well matured, while wheat contains the most when just heading out.<sup>3</sup> Thus the potassium content of a corn crop when cut is a very good index of the potassium needs of corn, whereas the potassium content of a harvested wheat crop does not indicate the true potassium requirements of that crop.

It has been found that a turnip crop requires much more phosphorus during its growth than is indicated by its chemical composition at harvest time.

4. Some harvested crops consist of the entire growth, while others consist only of the edible or usable portion. This fact must be remembered when the table is studied. For example, in comparing a twelve-ton corn crop and a fifteen-ton sugar beet crop, it would appear that the corn crop is the greater feeder on all the elements. The corn crop consists of the entire growth; the sugar beet crop only the marketable roots. In case of the fifteen-ton beet crop at least 6.2 tons of green leaves and tops are left on the field, containing about forty pounds of nitrogen, 6.5 pounds of phosphorus, 12.5 pounds of potassium and 30.5 pounds of calcium. Thus to grow a fifteen-ton sugar beet crop the soil on each acre

---

<sup>3</sup> The amount not needed in later growth or development goes back into the soil, either washed from the leaves or migrates through the roots.

must give up one hundred eighteen pounds of nitrogen, seventeen pounds of phosphorus, ninety-two pounds of potassium and 38.5 pounds of calcium.

In case of a fifteen-ton cabbage crop, at least eleven tons of material are left on the field. Thus a fifteen-ton cabbage crop requires for its production approximately one hundred eighty pounds of nitrogen, sixteen pounds of phosphorus, one hundred

twenty-five pounds of potassium and sixty-two pounds of calcium.

In case of hemp, it would seem that a soil needs to give up only small amounts of the elements to produce a good crop, and that it ought to grow well on poor soils. On the contrary, it requires a fertile soil to grow a good crop of hemp.

#### Root Systems of Crops Differ.—

Some plants have extensive and well developed root systems enabling



FIG. 26.—Root-hairs are the absorbing portion of plant roots. These root-hairs come into intimate contact with the soil. A, root-hairs of mustard plants, with soil adhering and with soil removed. B, root-hairs of wheat, when very young, and four weeks later. (After Sachs.)

them to draw plant-food elements and water, particularly, from large volumes of soil (Figs. 26 and 27). Corn and alfalfa are typical examples. Such crops as onions, cabbage and beets have much less extensive root systems.

It is the nature of some plants to develop fibrous and much branching roots largely in the tilled portion of the ground—these are commonly called shallow rooted plants.

**Farm Plants are Interesting Subjects for Study.**—In the

preceding paragraphs the importance of plant study is emphasized. If anyone wishes to grow any kind of a crop most successfully he should become familiar not only with the best cultural methods in growing it, but, as far as possible, with all its habits and characteristics as well.



Fig. 27.—The root-hair in the soil. hh, root-hair; e, portion of main root; 1, air space; 2, soil grain; 3, water film. (After Sachs.)

**Plant-food Elements Removed by Fruit Crops.**—It is of interest to note the amounts of elements removed from the soil by some of the common fruit crops. The following table has been prepared from all available data:

*Plant-Food Elements Removed by Fruit Crops*  
(Pounds per acre)

Fruits	Average annual yield per acre	Number trees per acre	Nitrogen (N)	Phosphorus (P)	Potassium (K)	Calcium (Ca)
Apples.....	100 bbls. (300 bu.)	50-100	13.8	2.0	14.5	1.0
Cherries.....	300 cases (150 bu.)	108	16.0	2.6	16.6	1.0
Peaches.....	450 bu.	100	19.2	4.1	32.7	1.7
Pears.....	500 bu.	75	10.2	1.6	19.1	1.8
Plums.....	250 bu.	100	21.7	3.6	25.7	2.0
Raspberries...	3000 qts.	...	10.0	1.7	10.0	...
Strawberries..	6000 qts.	...	13.5	4.5	22.5	0.6*

\* Strawberries need but little calcium, even in leaf and stem development.

Fruit cannot be produced without the formation of leaves and new wood. This requires additional amounts of the plant-food elements—between twenty and fifty pounds of nitrogen, two to four pounds of phosphorus, ten to twenty-five pounds of potassium and twenty-five to eighty pounds of calcium per acre.

#### THE SUPPLY OF NITROGEN, PHOSPHORUS AND POTASSIUM IN SOILS

Having studied the draft that crops make upon the important elements of the soil, let us now consider the soil reserve or supply of these elements. Since calcium and lime are fully discussed in relation to acid soils in Chapter XIII, our attention here is directed to nitrogen, phosphorus and potassium.

**Supply Varies in Different Soils.**—It is to be expected that chemical analyses should show great variations in the amounts of nitrogen, phosphorus and potassium contained in different classes and types of soils mentioned in Chapter II (Fig. 28). The amounts of these elements in any particular soil expressed in terms of per cent mean nothing or very little to the average person when he has no standard for making comparisons.

**Simple Standards for Comparing Soils.**—The following table, based on the averages of many analyses, will be of much help to the beginner in judging soils of similar classes and types when only chemical analyses are given.

*The Supply of Nitrogen, Phosphorus, and Potassium in Soils*

Soils	Per cent			Pounds per acre 7 inches deep		
	Nitrogen (N)	Phosphorus (P)	Potassium (K)	Nitrogen (N)	Phosphorus (P)	Potassium (K)
Productive silt loam or clay loam . . . . .	0.25	0.1	2.0	5,000	2,000	40,000
Poor sand . . . . .	0.08	0.02	0.5	2,000	500	12,500
Muck (average)	1.00	0.1	0.75	10,000	1,000	7,500
Peat (well decomposed) . . .	3.00	0.12	0.3	15,000	600	1,500

Some soils may be rich in one or two of these elements and poor in others.

It is not to be inferred that a silt loam is not a productive soil unless it contains at least one-quarter of one per cent nitrogen, one-tenth of one per cent phosphorus and two per cent potassium.



There are many productive silt loams that do not contain such reserves as here represented. It is well, to be sure, to possess a farm of silt loam having a supply of plant-food elements at least equal to that contained in an average, productive silt loam; or a sandy farm having soil analyzing much better than a poor sand. And it is more encouraging to possess peat that analyzes 0.15 per cent phosphorus and 0.5 per cent potassium than it is to have peat containing 0.07 per cent phosphorus and 0.2 per cent potassium. The cropping possibilities of a soil are greater when the supply of plant-food elements in it is good.

**Per Cent not the Best Basis for Comparing the Supply of Plant-food Elements in Soils.**—When we compare the per cent in the table on page 70, we see that average peat contains twelve times the amount of nitrogen contained in a productive silt or clay loam; but when we compare the amounts in pounds per acre seven inches deep, we find the comparison to be only three times. It is to be further observed that peat shows a higher per cent of phosphorus than silt loam; but in an acre seven inches deep of peat there are only 600 pounds of phosphorus while in a silt loam there are 2000 pounds. The explanation of this lies in the fact that soils vary a great deal in weight. In round numbers an acre of each of these soils seven inches deep weighs when dry as follows:

Sand.....	2,500,000 lbs.	Muck.....	1,000,000 lbs.
Silt loam or clay loam...	2,000,000 lbs.	Peat.....	500,000 lbs.

**Peat Soils are Deficient in Potassium and Phosphorus.**—In comparing the supply of plant-food elements of soils on the "pounds per acre" basis, we observe that peats are abundantly supplied with nitrogen, but are deficient in potassium and phosphorus (see Chapter IV). We can now fully understand why these soils require mineral fertilizers, viz., potash and phosphates.

**Peat Lands are Sometimes Deceptively Advertised.**—To him who is unfamiliar with soils, a comparison of the per cents of the plant-food elements contained in them seems a reasonable basis for judging their agricultural values. A drained peat analyzing three per cent nitrogen and 0.1 per cent phosphorus may seem to him as good if not better soil than a prairie loam analyzing 0.26 per cent nitrogen and 0.08 per cent phosphorus. Such a comparison is often used in advertising peat lands. It is well, therefore, to secure full information before investing (Fig. 28).

**Subsoils Contain Plant-food Elements.**—It is important to bear in mind that subsoils also contain the important elements.

In general, the surface soil contains more nitrogen than the subsoil, owing to the presence of more organic matter. Some deep, black soils may have as high a percentage of nitrogen in the subsoil (to a limited depth) as is contained in the surface stratum.

The percentage of phosphorus in the surface layer is commonly greater than or equal to that contained in the subsoil. There is often a close relationship between the phosphorus content and the amount of organic matter in mineral soils. This accounts for the higher phosphorus content of the upper strata. During the virgin state the roots of grasses and other plants brought up considerable phosphorus from the subsoil from a depth of about

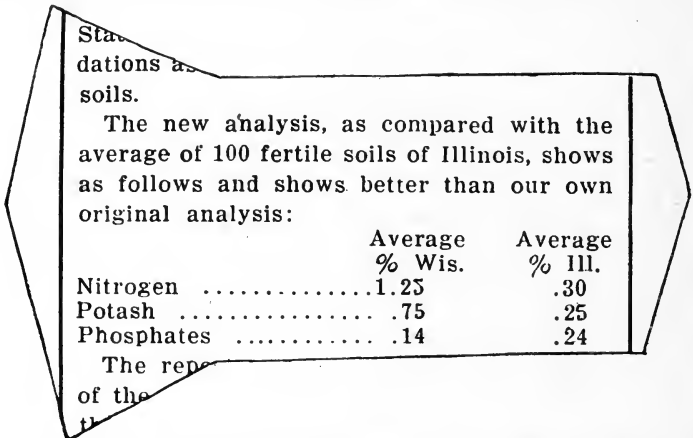

FIG. 28.—How some peat land was advertised. This particular Wisconsin peat was compared with the best Illinois prairie soil, which averages about 0.25 per cent nitrogen, 1.8 per cent potassium and 0.08 per cent phosphorus.

two or three feet, and this became stored in the organic matter accumulated in the top soil. On exhaustive cropping, the higher phosphorus content of the surface soil is gradually reduced until it equals at least the percentage contained in the subsoil.

The potassium content is usually greater in the subsoil, especially when they are fine textured. More potassium is found in subsoils in humid climates because of the presence of more fine particles which are not only richer in potassium than the coarser surface particles, but which absorb much of the potassium leached down from the surface stratum.

In arid and semi-arid soils the phosphorus and potassium content of the surface soil is very much the same as that of the subsoil.

Since roots extend into the deeper layers of soil, the subsoil is to be regarded as a portion of the feeding ground for crops. Subsoils which are porous, permitting air to enter freely, may contribute considerable amounts of plant-food elements to crop needs. The fact that in humid climates most feeding roots are to be found in the tilled portion of the ground, especially in the heavier soils, explains why the draft upon the surface layer is much greater.

**Exercises.**—Compare an average yield of one of your local crops with the table of plant-food elements removed, and determine the amount and value of plant-food elements removed from one acre.

2. Minor crops may be considered also.

**Projects in Crop Adaptations.**—On a given field lay off small strips along one side where the soil is probably of average fertility. On these strips grow several useful crops as oats, barley, rye, wheat, buckwheat, millet, sorghum, corn, cowpeas, soybeans or others. Compare them in growth, yields, and study their probable needs. Keep careful records and notes and from the trials determine what crops are best suited to the soil.

**Buckwheat Project.**—Try the growth of buckwheat on poor soil and thus decide whether it would aid in production of green manure for the improvement of that soil.

**Projects on Poor Soil.**—Compare the growths of barley with oats on poor soil. Determine which requires the richer soil for good returns.

2. In like manner compare barley with rye, and compare oats with rye.

3. Any one of these as barley (or other crops) should be grown on both rich and poor soil. This will demonstrate the needs of the crop.

**Field Studies.**—Make studies of soil conditions in a field where grain lodges badly.

2. Collect whole plants of a number of grasses, legumes, grains, etc. Compare their root systems to determine this depth of feeding.

QUESTIONS

1. Name the elements most commonly studied in relation to crop production.
2. Are soil particles plant foods? What was taught at one time?
3. In what forms do plants secure the elements they require?
4. How much nitrogen, phosphorus, potassium and calcium is removed from one acre by a 65-bushel corn crop? By a 50-bushel oat crop? By a 1500-pound tobacco crop? Which of these crops require the most calcium?
5. A man grew the following crops on an acre: 1st year, cabbage yielding 15 tons; 2d year, corn yielding 12 tons; 3d year, barley yielding 40 bushels. How many pounds each of nitrogen, phosphorus and potassium were removed from that one acre during those three years? How much if there were 20 acres?
6. A ten-acre field was cropped three years as follows: 1st year, sugar beets averaging 12 tons per acre; 2d year, wheat averaging 25 bushels; 3d year, corn yielding 52 bushels per acre. How many pounds of each of the important elements were removed from this field during these three years?
7. How much nitrogen is required to grow a bushel of corn? A bushel of oats?
8. In what part of crops is found the most phosphorus? The most potassium? The most calcium?

9. What per cent of the total phosphorus in a wheat crop is lost to the soil on the farm when wheat is sold? What per cent of the potassium is sold?
10. What is the relation between the nitrogen requirement and the protein content of crops? Illustrate. What relation is there between the carbohydrate content and the potassium requirement of crops?
11. Name some crops that draw heavily upon the plant-food elements. What are the elements required by tobacco in large amounts?
12. A farmer says that wheat stands up better than oats on a field formerly a hog pasture. Explain why.
13. When grain lodges badly what crops should be grown instead?
14. What causes lodging of grain, and how may it be prevented?
15. Discuss alfalfa growing in relation to poor soil.
16. Is timothy more of a "soil robber" than oats? What do you think of tobacco as compared with corn in this respect?
17. Why can buckwheat and rape grow very well on poor soils? What indicates a strong feeding power in some plants? Weak feeding power?
18. Explain why barley requires a richer soil than oats. What is the meaning of "rich" soil?
19. How can the fertilizer needs of any crop on any soil be best determined? Why?
20. Construct a table showing the amounts of "N," "P," "K" and "Ca" required to grow a 12-ton corn crop, a 15-ton sugar beet crop, a 15-ton cabbage crop and a 300-bushel apple crop. (See tables.)
21. How do the root systems of crops differ?
22. What are root hairs? Explain their function (Figs. 26 and 27).
23. What knowledge is necessary to grow a crop most successfully?
24. What is the nitrogen, phosphorus and potassium content of an average productive silt loam, expressed in per cent? What can you say of the cropping possibilities of soils well supplied with plant-food elements?
25. Why is not the per cent basis the best for comparing the amount of plant-food elements in soils?
26. Why do peat soils require potash and phosphate fertilizers?
27. How may peat lands be deceptively advertised? Illustrate.
28. Tell of the nitrogen, phosphorus and potassium contained in subsoils.
29. What colors of soil and of subsoil have you seen?
30. See outline summary of this chapter in table of contents.

## CHAPTER VII

### CROP PRODUCTION AND SOIL FERTILITY

**Factors in Crop Production.**—Successful crop production depends upon five factors, viz.:

- (1) Fertile soil. (2) Good seed. (3) Favorable temperature.
- (4) Light. (5) Protection from injury.

**Fertile Soil.**—Good soil is a fundamental factor. Not only should the soil be well drained and cultivated, but it should possess all the qualities, properties and conditions which impart to it productive power. The adjective “fertile” is commonly used in describing such a soil.

It is not always possible to select fertile soil. Sometimes only a portion of a farm is productive. Sometimes the soil of a farm is sand, sometimes peat, and sometimes it consists of several kinds, rich and poor. Happily it is within the possibilities of any thinking farmer to transform a poor or unproductive soil into a productive one; and he is a public-spirited man, indeed, whose ambition it is to bring about such a transformation.

**What Makes a Soil Fertile.**—The qualities, properties and conditions which impart productive power to a soil are as follows:

(a) *A Suitable Moisture Supply.*—Without water nothing can grow. Many lands have been turned from deserts into gardens just by the addition of water through irrigation. Very frequently crops even in humid climates and on good soil are much reduced, or fail entirely because of drought. Sometimes there is too much water in the soil—for this reason wet lands must be drained before they can be made to grow any crop at all—excepting wild hay.

(b) *Plenty of Air in the Soil.*—Air in the soil is essential to favor root growth, to favor the development of the helpful soil organisms and to enable the necessary chemical changes to take place.

(c) *Good Tith.*—It is important that the physical condition of the soil should be such as to enable the young plants to get the best possible start—to become quickly and firmly established in the soil and to favor their development (Chapter V).

(d) *The presence of helpful soil organisms* of which there are several kinds; viz., bacteria which cause the formation of the nodules on the roots of legumes; bacteria, molds and fungi which help make plant-food elements available, and are helpful in other ways. Angleworms may also be mentioned in this connection.

(e) *A good supply of available plant-food elements* from which crops may secure sufficient nitrogen, phosphorus, potassium, calcium, etc., to permit of good yields.

(f) *The absence of harmful agents in the soil*, such as poisons; too much salt, such as alkali; certain diseases; too much water, etc.

These factors are further discussed under "soil fertility," and in the following chapters.

**Good Seed.**—It is generally recognized that good seed is a factor of much importance. Poor seed in poor soil means miserable failure. Good seed in poor soil renders just as little, if not less, for labor than poor seed in good soil. But the best combination is good seed in good soil.

The emphasis put on good seed in agricultural development today leads some to think that this idea is a product of the twentieth century. Not so. Early agricultural writings reveal the fact that the value of good seed was much discussed in the old countries hundreds of years ago. The following quotation, taken from a book, "Way to Get Wealth," by G. Markham, printed in London in 1660, is interesting in this connection:

" . . . You shal then take your Seed which would be the finest, cleanest, and best Wheat you can provide, and after the manner of good Husbandry, you shal sow it on the ground very plentifully, not starving the ground for want of Seed (which were a tyrannous penury) nor yet choaking it with too much (which is as lavish a foolery) but giving it the full due, leave it to the earth and Gods blessing."

**Factors Involved.**—In spite of the fact that much has been said and written in this generation about good seed, there are still many who fail to give this factor any serious consideration. A high germination test is not the only indication of good seed. There is also involved a selection of size of seed, and for adaptability, purity, disease resistance, high yield and superior quality.

**Size and Weight.**—There is a decided advantage in the use of large or heavy seeds over small ones, even though they may be of the same variety and all of high germination test. The Ontario Agricultural College (Canada) produced a seven-year average of

sixty-two bushels of oats per acre from large seed and only forty-seven bushels from small seed. Both the small and large seed were selected from the same stock each year.

**Disease Resistance.**—The Wisconsin Station has developed a variety of cabbage resistant to the disease of “yellows” (Fig. 165). Much work has already been done by investigators in developing disease-resistant plants.

**Seed Improvement.**—The Cornell Station of New York has demonstrated a yield of 3.57 tons of timothy hay per acre with improved varieties as compared with 2.04 tons with ordinary timothy. The test was made on the same kind of soil and with seed of equally high germination test. This is a seventy-five per cent increase in favor of improved varieties. The quality of hay was also much better.

As a result of working on the increase and decrease in protein and oil content of corn, the Illinois Station developed from a single variety of corn in ten years' time, one strain containing 65 per cent more protein than another, and a third strain containing 177 per cent more oil than a fourth strain.

These are but a few of many examples illustrating the possibilities of good seed and the advancements that are being made in improving varieties.

**Favorable Temperature.**—The temperature at which plants make their best growth varies with different farm crops. In diversified farming there is no weather but what is good weather, since when it is unfavorable for one or two crops it is favorable for the others. A hot sun, though favorable for corn, often causes injury to the Irish potato in “burning” the leaves (sun-scald). Cool and moist weather during the fore part of a growing season is favorable for grains, but unfavorable for corn. Our poor corn years are usually the result of cold, wet weather during the summer and fall months. Excessive heat and much dampness generally cause much damage to grains in favoring the development of leaf and stem rusts.

Since weather is beyond the control of man, except under artificial conditions, the best that a farmer can do is to plant his seed at such time as to enable the respective crops to take advantage of the favorable temperature conditions. In this the farmer is guided in his activities largely by the average weather of his section or locality (Chapter V).

**Light.**—In Chapter V we learned that sunlight is necessary for

plants as the source of energy in the manufacture of foods. Under field conditions duration of light seems more important than intensity. Some plants require much sunlight while others do better when shaded. Crops which manufacture much starch and sugar require much sunlight. In order to increase the succulence and delicacy of such crops as asparagus, cauliflower, celery, lettuce and radish, they are sometimes grown under half-shade. In case of cauliflower more desirable heads are produced through shading brought about by bringing together and tying the leaves in the form of a head. Shading is employed in forcing rhubarb, in ginseng culture, and has proved of much importance in pineapple culture in Florida.

The sugar beet is a crop requiring abundant sunlight together with plenty of moisture, especially during early growth. These conditions are found most favorable in the irrigated districts of the Rocky Mountain and Pacific States—hence in these districts the sugar content of beets is usually higher than those grown elsewhere.

**Shading a Factor in Weed Killing.**—Many have experienced much difficulty or failed entirely in trying to establish a lawn under heavy shade, even when all other conditions were favorable. Lack of sunlight under such conditions is the cause of failure. Weeds may be killed through the use of so-called “smothering crops.” These are fast-growing crops which quickly rise above the weeds in thick growths, and in so doing shut out the sunlight from the weeds beneath.

It is commonly observed that a field growing a cultivated crop after good clover or alfalfa sod is exceptionally free from weeds, except when weed seeds have been introduced through manure application. The explanation of this lies mainly in the fact that the thick growth of clover or alfalfa killed the millions of small seeds which started to grow, mainly by depriving them of sunlight.

**Weeds May Smother Crops.**—Many a seeding of alfalfa, or planting of potatoes, for example, has produced no returns because weeds were allowed to get ahead of the young plants, and thus they were robbed of sunlight as well as of moisture and plant food elements.

**One Crop May Deprive Another of Sunlight.**—Lodged grain usually kills out the grass seeding. This killing is due mainly to the exclusion of sunlight. It is very important that seedings of clover and alfalfa, in particular, should not be entirely robbed of



sunlight by too thick growth of grain. Clover and alfalfa seedings are generally more successful when the nurse crops are not sown too heavily. A less amount of grain sown per acre enables the young seeding to get more sunlight. When nurse crops are drilled in a north and south direction, much more of the midday sunlight reaches the young clover or alfalfa, thus insuring a better stand of the hay crops than when the nurse crops are drilled east and west, or sown broadcast. This is especially true in the northern states.

**Protection From Injury.**—A farmer may be defeated in his plans for raising good crops if he fails to protect them, if need be, from injury by animals, birds, flood-water, weeds; from injury by insects, as beetles, worms and aphids which feed on the foliage; from damage through lodging (smothering the seeding); and injury by diseases as smut, scab, blight, and if possible, by certain rusts. Proper fencing may be an important consideration in protection, likewise poison bait for rodents and grasshoppers, spraying, treating grain and onion seeds for smuts and seed potatoes for scab, killing weeds by cultivation, getting rid of surplus water by proper drainage, etc.

#### SOIL FERTILITY

Productive soils are commonly described as "fertile," also productivity of such soils is most commonly referred to as "fertility."

Before proceeding further it is important to have a clear idea of the meaning of fertility. In the first place the word "fertility" is but the noun form of the adjective "fertile," and hence carries the same general meaning.

**Soil Fertility Defined.**—Fertility means "state or quality of being fertile; fruitfulness; productiveness." Soil fertility<sup>1</sup>, therefore, is to be interpreted to mean the power of a soil to produce good or large yields.

To maintain soil fertility means to maintain productivity.

To increase fertility means to increase the productive power of a soil, or to cause it to produce still better yields.

A soil is said to have lost its fertility when it ceases to be productive, or when it no longer possesses the ability for producing good yields (Fig. 29).

Fertility does not mean the ability of a soil for producing the

---

<sup>1</sup> E. J. Russell, Soil Conditions and Plant Growth.

highest possible yields. We can speak of degrees of fertility in a similar sense as degrees of richness, for example.

Very fertile soil or very high fertility implies a very high productive power. Low fertility implies that the yielding power is not very good. "Infertility" means the lack of productive power.

Fertility as applied to a soil in Wisconsin, for example, does not imply that that soil has the ability for producing good or high yields of all kinds of crops to be found in the world; but it has meaning only in relation to those crops grown in that particular climate or section.



FIG. 29.—Poor soil, poor crop. This soil is not fertile because it does not produce a good crop.

**Crops Indicate Fertility.**—Crop growth is the only indicator of soil fertility, and the use of good seed is the only proper means in testing fertility. Since the requirements and adaptability of different crops vary, a soil may be fertile for one or several kinds of crops and not for another (Figs. 30 and 31); for example, a soil may grow excellent crops of clover, potatoes (Fig. 32), corn, and grains, but fail absolutely to grow alfalfa, for lack of proper inoculation.

**Factors Determining Fertility.**—The factors which determine soil fertility are discussed in the first pages of this chapter. They may be thus enumerated as positive and negative factors:



FIG. 30.—A fertile soil This soil possesses all the qualities, properties and conditions which impart to it productive power.



FIG. 31.—Harvesting hemp in Wisconsin. Crop growth is the indicator of soil fertility This particular soil is in a high state of fertility.

*Positive factors:* (1) A suitable moisture supply in the soil. (2) Sufficient air in the soil. (3) Good tilth (Chapter V). (4)

Presence of helpful soil organisms. (5) Sufficient available plant-food elements, nitrogen, phosphorus, potassium, calcium (carbonate of lime).

*A negative factor:* (1) The absence of harmful agents in the soil.



FIG. 32.—Having power for maximum production. Yield 550 bushels to the acre—following clover. A complete fertilizer was used at the rate of 2000 pounds per acre. (Maine.)

**Soil Fertility Illustrated.**—Fig. 33 will help the student to gain a clearer idea concerning fertility.

Let the tank represent a soil.

The capacity of the tank for holding water represents fertility, or the power of the soil for producing a good or high yield.

The staves which determine the water-holding capacity of the tank represent the positive factors which determine soil fertility.

The tank being free from any leaks represents the negative factor, viz., the absence of harmful agents.

If all the staves were as high as the concrete sides of the tank, the tank would then hold its greatest amount of water. If all the fertility factors were most favorable, the soil would have power for producing maximum yields.

Just as the water-holding capacity of the tank may be limited by the shortest stave, so fertility or the productive power of a soil may be limited or brought to naught by one deficient element or an unfavorable soil condition. Thus it is possible for a soil to

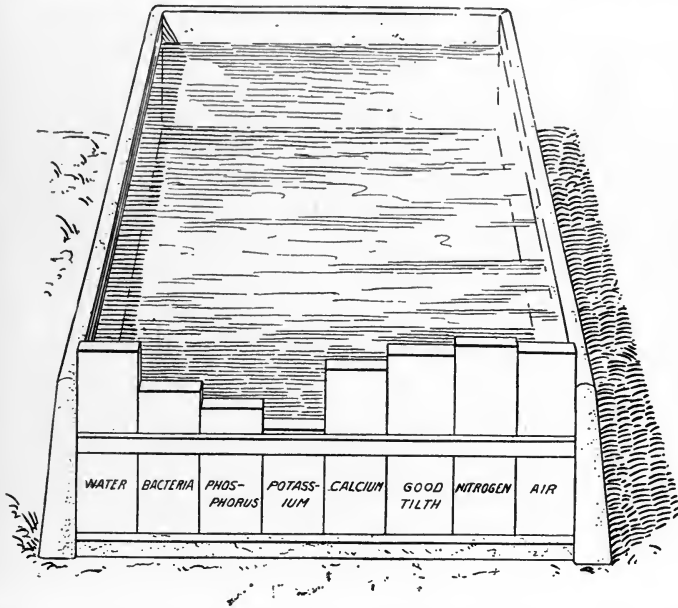

FIG. 33.—Soil fertility illustrated. Just as the water-holding capacity of the tank may be limited by the shortest stave, so fertility or the productive power of a soil may be limited or brought to naught by one deficient element or an unfavorable condition.

lose its fertility or productive power through the depletion or loss of a single fertilizing element.

**Unfavorable Factors.**—Many soils are unproductive because one or more factors are unfavorable. In case of drained peat, the common cause of poor crops, or failures, is the lack of potassium. This condition can be corrected through the use of potash fertilizers—or in terms in harmony with Fig. 33, the shortest staves may be lengthened by applying fertilizers carrying potassium.

In many instances, poor yields and failures in growing alfalfa,

soy beans, beans, peas and other legumes may be due to no other cause than the lack of proper nodule-forming organisms. In hundreds of cases soils fertile for corn, potatoes, and grains, fail to grow alfalfa because of both a lack of calcium (carbonate of lime) and alfalfa nodule-forming organisms.

On many long-cropped prairie soils deficient available phosphorus is a common cause of low fertility and poor crops.

**Soil Exhaustion.**—Some soils which were at one time productive are now regarded as exhausted, depleted or “worn out,” because



FIG. 34.—Depleted lands (in background), typical of the Appalachian and Blue Ridge slopes. Wooded hillsides are cleared of timber, cultivated, and through erosion and exhaustive cropping are rendered useless, and allowed to revert to timber. In foreground, new land recently cleared is in tobacco. (Kentucky.)

they no longer respond to cultivation as they formerly did (Fig. 34). An exhausted or depleted soil implies that something has been used up or taken out of it. That “something” is commonly understood to mean the fertilizing elements; viz., nitrogen, phosphorus and potassium. In some instances soil exhaustion may be attributed largely to the removal, mainly through cropping and leaching, of some one or all of the three named elements; not the removal of the “total” amount, for this is impossible, but the removal of the “available” supply. If no phosphorus, for example, were lost through leaching, it would require only about sixty years

of exhaustive cropping to reduce the total phosphorus supply of a fertile silt loam one-half.

The effect of exhaustive cropping on the phosphorus supply is well illustrated in the following study of two pairs of soils which represent two different silt loams. In each case the "virgin" and the "cropped" samples are the same soil; the one has never been under cultivation and the other has been subjected to exhaustive cropping for over fifty years.

*Effect of Exhaustive Cropping on the Phosphorus Content of Soils*

Soil	Phosphorus content			
	Virgin soil		Cropped soil	
	Per cent	Pounds in 1 acre 7 inches deep	Per cent	Pounds in 1 acre 7 inches deep
I	0.12	2400	0.06	1200
II	0.074	1480	0.04	800

The following is a brief outline of the history of these two soils:

I. "Cropped sixty years, largely to wheat during the first ten or twelve years; then corn and oats; clover ten years. The land is now in a depleted condition."

II. "Cropped sixty-three years. During the first thirty-four years wheat was grown almost continuously. Since 1878 it has been rotated to corn, barley, oats and rye. It has never been seeded down or manured and is in a badly exhausted condition."

**Soil Exhaustion Not Confined to Just One Element or Condition.**

—Generally an exhausted or depleted soil is the result of several unfavorable conditions, which, acting together, bring about a state of infertility. All the fertility factors are necessarily affected; and instead of their acting favorably for good yields, they act unfavorably and thus cause poor crops or prevent any yields at all. The fertility factors are unfavorably affected largely by the removal of organic matter, by the removal of available nitrogen, phosphorus and potassium, by the removal of available calcium in the form of carbonate of lime, and by poor tillage. It is not always easy, therefore, to restore the original fertility of a badly depleted soil. In many instances it has proved a tedious and expensive undertaking.

**Diagnosing Infertility.**—Knowing the meaning of fertility and the factors determining it, any one can diagnose a case of infertility or low productive power with a fair degree of accuracy, or gain an idea, at least, as to the cause of failure or low yields. A knowledge of the cropping history and past management of the soil in many instances will greatly aid in arriving at any definite

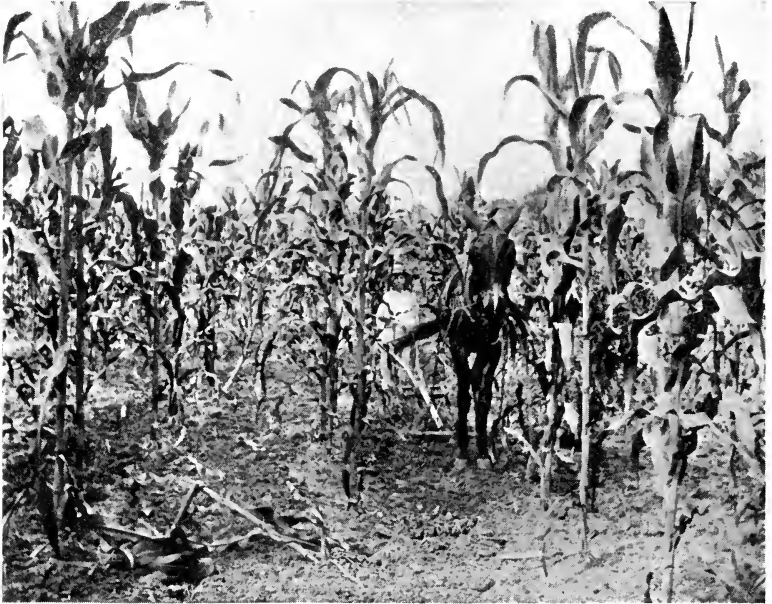

FIG. 35.—This crop yielded 75 bushels of corn per acre. Rows were four feet apart and hills in the rows three feet apart—one stalk in each hill. The secret—each stalk produced a little less than  $1\frac{1}{2}$  pounds of ear corn. (Mississippi.)

conclusion. For example, alfalfa failure on some soils may be due to no other cause than the absence of alfalfa nodule-forming organisms.

**The Secret in Growing Good Crops.**—The secret of a good yield of corn consists in causing each stalk in the field to produce at least one good ear (Fig. 35). To attain this object a good farmer, because of experience, selects a workable and desirable soil, prepares a good seed bed, increases the richness of the soil by adding manure or commercial fertilizers, cultivates the growing crop as well as he knows how, and trusts to the weather for the rest (Fig. 36).



When we analyze this method of procedure, we find that the farmer unconsciously brings into play the factors which determine fertility; in other words, his whole program centers on soil fertility. It is true in respect to growing a good yield of any crop. This emphasizes the importance of soil fertility and explains why so much study is given to it.

**Most Soils Can be Improved.**—In the next six chapters we shall study in detail the several factors which determine fertility in their relation to soil improvement and to the maintenance of fertility. There are very few soils that cannot be improved in some way. To maintain and increase soil fertility should receive the serious consideration of every farmer, because fertile soil is the basis of a successful and prosperous agriculture. It is, indeed, a patriotic duty of every farmer to maintain the fertility of his soil, and to pass his land on to his children, or fellow farmers in as good if not better condition than when it came into his hands.



FIG. 36.—Twenty-six potatoes from a single hill, totaling 6½ pounds—all from a piece of potato having two strong "eyes." A good seed bed, a good supply of available plant-food elements, a good moisture supply, the absence of any disease, and protection from insect pests were factors which made this yield possible.

**Exercises With Seeds.**—With the use of a hand lens examine specimens of good and poor seeds. The samples should include fresh and old clover seeds, chaffy and clean grass seeds, heavy and light grain, pure seeds compared with others foul with weeds, etc.

**Project Studies.**—Compare the growth of crops where poor lots of seeds have been used in contrast with the best seeds. These may be on small plots.

2. Grow several lots of seed that have been selected for disease resistance. Test their efficiency by contrasting them with others grown in similar surroundings. These may include cabbage which resists yellows, tobacco and tomato which resist wilts, or others.

3. Sweet potatoes which have been selected from plants which are immune to black rot disease should be grown as a home project. From the crop select those which are perfectly immune and that are the best in yield, etc.

4. Project in seed improvement for various farm and garden crops may be conducted at homes of students.

**Field Studies.**—1. Compare growth where the tillage is thorough with the same crops under poor tillage.

2. Find examples where weeds have been smothered by heavy seeding of crops as grains, cowpeas, millet, buckwheat, etc.

3. Make field studies to attempt to diagnose the fertility or infertility of field at home or on other farms. See the suggestions in this and other chapters.

### QUESTIONS

1. Name the factors upon which successful crop production depends.
2. What is meant by a fertile soil?
3. What makes a fertile soil?
4. What is a good combination to have in order to raise good crops?
5. What is good seed?
6. What advantage is there in planting large seeds rather than small ones of the same variety? In planting disease-resistant varieties? In planting improved varieties?
7. How may weather conditions affect crop growth?
8. What relation has the weather to the farmer's activities?
9. Discuss the relation of light to crop production.
10. What are the best conditions under which to grow sugar beets?
11. What are "smothering crops"? Explain how clover and alfalfa may serve in this capacity. What about weeds?
12. What precaution should be observed in sowing nurse crops?
13. How may a farmer protect his crops from injury?
14. What is the meaning of soil fertility?
15. Give meaning of "to maintain fertility." "To increase fertility."
16. When is a soil said to have lost its fertility? What is infertility?
17. Fertility of a soil in your locality has meaning only in relation to what crops?
18. What indicates soil fertility?
19. Name the factors determining fertility.
20. When is it possible to obtain maximum yields?
21. How may a soil lose its fertility or be limited in its productive power?
22. Explain why peats are frequently unproductive. Give remedy.
23. What are common causes for failure of legumes?
24. What is the meaning of "soil exhaustion"? What is a common cause of soil depletion?
25. What is the effect of exhaustive cropping on the phosphorus supply of soils? Illustrate.
26. Explain why it is not easy to restore the original fertility of a badly exhausted soil.
27. Illustrate how the cause of infertility or low yields may be reasoned out.
28. What is the secret in growing a good crop of corn?
29. Suppose corn is planted in hills 3 feet 8 inches apart each way, 3 stalks in the hill, and each stalk produces an ear weighing three-quarters of a pound when cured. What would the yield be? What would you do to grow such a crop?
30. For an outline summary of this chapter see table of contents.

## CHAPTER VIII

### SOIL WATER AND ITS RELATION TO SOIL FERTILITY

Water is a most important though variable factor affecting soil fertility. Crop yields may be much reduced by a lack of water or by too much of it. The life processes and special activities of plants as well as of animals are at all times dependent on the water supply.

**Why Plants Require Water.**—In relation to plants, water serves a number of purposes, as—

*a. A nutrient.* It may without change become a part of the plant cell, or it may contribute to the making of foods.

*b. A carrier for plant-food elements and plant-food.* The salts of the soil which contain nitrogen and the mineral elements, and the carbon dioxide of the air, which contains the carbon must be brought to the leaf cells in soluble form before they can be utilized in food manufacture; and when the foods are made, they are translocated within the plant in soluble form by means of water (p. 50).

*c. To keep the cells turgid,* or expanded, to prevent wilting. When plants cannot get all the water they need they wilt, and when they remain wilted they die.

*d. A cooling agent.* The evaporation of water from the leaves prevents their getting too warm. It has been found that even with evaporation the leaf temperature may be ten to fourteen degrees higher than that of the surrounding air.

*e. An aid in life processes.* Water is necessary to permit of certain physical and chemical changes (life processes) within the plant.

**Further Importance of Water.**—Water is a great solvent in soils, and without it the necessary chemical changes in soils cannot take place; nor can the helpful soil organisms develop and do their work without moisture.

**Crops Require Much Water.**—Crops require tremendous amounts of water; for example, in a humid climate like that east of the Missouri River, about 152 barrels of water are required to produce one bushel of corn (Fig. 37). This means that in the

production of a seventy-five-bushel yield for each twenty-three-foot square area, the area necessary to grow one bushel must furnish to the corn growing on it at least 152 barrels of water during the growing season, or an equivalent of about thirteen inches. All this water passes up through the plants and evaporates from the leaves. This current of water passing up through the plant and evaporating from the leaves is called the "transpiration current."

Approximately 140 barrels of water are transpired by the oat

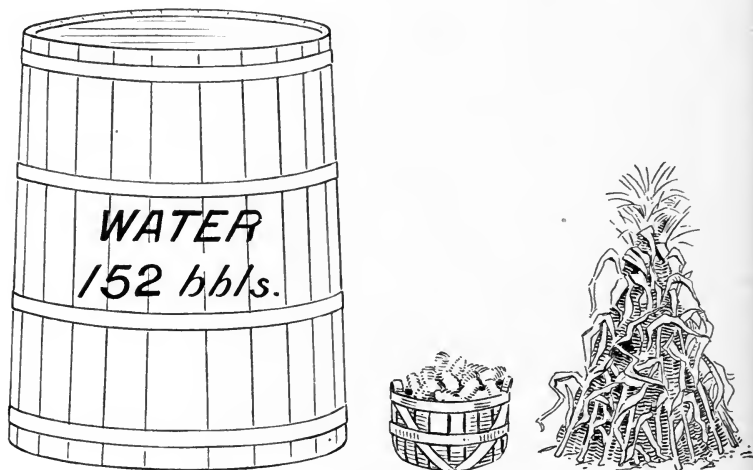

FIG. 37.—One hundred fifty-two barrels of water are required to produce one bushel of corn. The corn uses this amount of water. Water is an important factor in crop production.

plants for each bushel of oats produced. The same amount is required per bushel of barley. In a similar manner about 3800 barrels are required to grow a ton of clover hay, and about 4200 barrels to produce a ton of alfalfa hay.

**"Water Requirement" of Plants.**—The expression "water requirement" of a plant refers to its needs and means the amount of water that passes up through it and evaporates for every pound of dry matter produced. Plants differ in their water requirements, and, for the same plant, climate influences this requirement considerably. In this country scientists have found the water requirement of some crops to be as shown in the following table:

*Water Requirements of Some Crops*

Crop	Pounds of water transpired per pound dry matter produced	
	In a climate similar to that east of the Missouri river	In sections having 10 to 20 inches of rainfall, as in Colorado
Corn.....	271	368
Potatoes.....	385	636
Barley.....	464	534
Oats.....	504	597
Clover (red).....	576	789
Alfalfa.....	...	831
Common weeds.....	...	584 *

\* Average of four weeds—purslane, pigweed, lamb's quarter and ragweed.

**Soil Gives up More Water Than That Transpired.**—The figures in the table indicate only the amount of water that passes through the plant. In addition to this there is about one-fifth this amount of water lost by evaporation from the soil under conditions of good soil management.<sup>1</sup>

**Factors Influencing Water Requirement of Plants.**—The factors which influence the water requirement of crops are:

(a) *The weather.* If the air is hot and dry much more water is required than when the air is cool and moist. Wind and much sunshine also increase the amount of water transpired (last column in table).

(b) *The water supply in the soil.* When the soil contains a large supply of available water, plants are more lavish with it than when there is a low supply or when the soil gives up its moisture more slowly, as in a clay loam or silt loam.

(c) *Richness of the soil.* When other conditions are the same, a plant requires about one-half the amount of water when grown on a rich soil than when grown on a poor one.

(d) *Manure and fertilizer treatments.* The use of manure or commercial fertilizers on poor soils not only increases the yield but may decrease the water requirement of plants from thirty to fifty per cent.

**Importance of Rainfall at the Right Time.**—If the rainfall came at the right time and were evenly distributed in sufficient amounts, wonderful results would be obtained. The size of the hay crop is largely determined by the character and amount of the rainfall

<sup>1</sup> King's Soil Management.

during the earlier stages of growth. The oat yield is less dependent on the character of the rainfall than is the hay crop. An ideal oat year is fairly dry and warm during the time of sowing. During the growing season, however, oats should have from three and one-half to four inches of rainfall per month—about two inches every fifteen days. If the rainfall should be less than this the grain would not fill properly; if more, the oats generally grow too rank and lodge easily, especially on manured lands. Temperature also affects the yield. If the temperature should average rather warm while the oat crop is just heading out, the yield may be reduced from three to ten bushels per acre even though the moisture conditions be favorable.

The yield of winter wheat is determined largely by the rainfall during September and October, and by the snowfall and temperature during the winter.

**Water the Limiting Factor in Dry-farming.**—In dry climates the water requirement of plants is greater than in a humid climate; and, since the rainfall is so much less, water is the all important problem and the limiting factor of production in dry-land farming. Dry-land farming means the profitable production of useful crops without irrigation in districts receiving an annual rainfall of from ten to twenty inches. Every effort is made, therefore, in these districts to conserve the rainfall for use by crops.

**Moisture Often a Limiting Factor in Humid Climates.**—In a climate having an annual rainfall of more than thirty inches it would seem that moisture can never be a factor limiting soil fertility. The fact is, few seasons pass in which some important crop is not reduced from one-fourth to two-thirds in yield because of the lack of sufficient moisture, owing to the character and distribution of the rainfall. Sometimes the rain comes in torrential showers, and much of the water is lost as surface run-off; sometimes the snow melts rapidly while the ground is still frozen, and again much water runs away; at times the rain comes in light showers and is soon lost from the soil by evaporation; and frequently rains come at the wrong time or do not come at all when most needed.

**Water Problem in Semi-arid vs. Humid Climates.**—The real problem that confronts the dry-land farmer is, "Is it possible to conserve and use the rainfall so as to make it available for the production of profitable crops?"

In humid climates, because of water losses and irregularities in rainfall which materially affect crop yields, the question arises,

“How and to what extent can farmers conserve the rainfall and control the moisture in the soil to prevent any reduction in yield because of short dry periods or to lessen the damaging effects of drought?”

Before taking up the study of moisture conservation and control, it is necessary to consider first the forms of soil water, how water is retained by soils for crop use, the movements of water in the soil, and the capacity of soils for holding water for crops.

#### SOIL WATER

**Forms of Soil Water.**—Water in relation to soils may occur in three forms or conditions; as—

(a) *Gravitational or free water.* Water which, if opportunity be given it, will flow off or run down through the soil and away because of gravity.

(b) *Capillary water.* Water which is held by the soil against gravity after all free water is allowed to drain out, but which is free to move from soil particle to soil particle.

(c) *Hygroscopic water.* Moisture which exists in air-dried soil, or in soil in which plants permanently wilt. Usually a small amount of capillary water is also present in soils when plants wilt.

**Capillary Water Most Important.**—Free or gravitational water in wet lands should receive first consideration, since that is the water which should be gotten rid of before such lands can be brought under cultivation. In all soils having good drainage, however, capillary water is the most important, because this is the form which constitutes the soil moisture reserve from which crops draw their water requirements. Free water is detrimental to most cultivated crops. Rice and cranberries are crops which are peculiarly adapted to wet or saturated soils.

**How Soils Hold Capillary Water.**—Capillary water may be held in soils in three ways, viz.:

(a) In form of films around the soil grains.

(b) In organic matter as in a sponge.

(c) In some of the pore spaces within soil crumbs or granules (Fig. 6A).

A mineral soil can hold its greatest amount of capillary water when moisture can be retained in all the three ways mentioned.

A clean sand can hold capillary water only as films around the sand grains. A coarse sand is capable of retaining a comparatively small percentage of capillary water because of the less amount

of surface per unit volume to which water films can cling. A fine sand, on the other hand, can hold a larger percentage of capillary water because there is a much larger amount of surface over which water films can form.

A black silt loam or clay loam containing much organic matter and being crummy in structure can hold a large amount of capil-

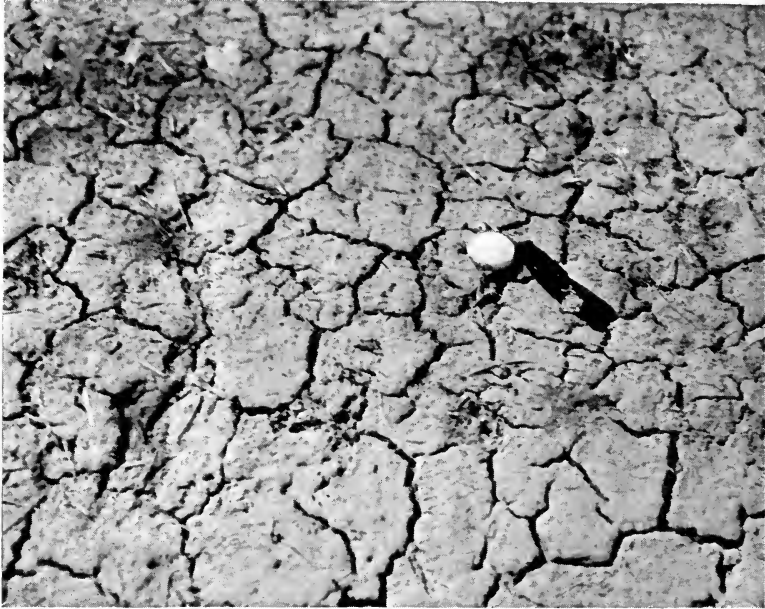

FIG. 38.—Checks and cracks aid entrance of water into the soil, and facilitate percolation of water through it. Silt loams, clay loams and clays check and crack when they dry out.

lary water, for three reasons: (1) its fine texture affords much surface for water films; (2) the organic matter has a high-water absorptive capacity, and (3) the crumbs contain pore spaces, many of which may become filled with water.

Peat holds the greatest amount of water per unit weight.

**Movements of Water in Soil.**—There are three important movements of soil water—percolation, seepage and capillary rise of water.

Percolation is the passing of free or gravitational water straight down through the soil (Fig. 38). This movement takes place through the pore spaces in between the soil particles or crumbs.



This movement is fast in a coarse sand and very slow in a clay loam of compact structure and in a clay.

**Percolation Prevents or Lessens Soil Erosion.**—If water can penetrate and percolate through a soil easily, soil erosion is prevented. A stubble field of heavy silt loam or clay loam on a hillside washes badly during a heavy rain because the water cannot readily soak into and percolate through it, and because the silt and clay particles are easily carried away by running water. If such a field were plowed so as to permit the water to enter the soil, erosion may be checked or much lessened.

**Drainage Depends on Percolation.**—When the ground is very muddy the pore spaces in the soil are filled with water; in other words, the soil is saturated or nearly so. If it were not possible

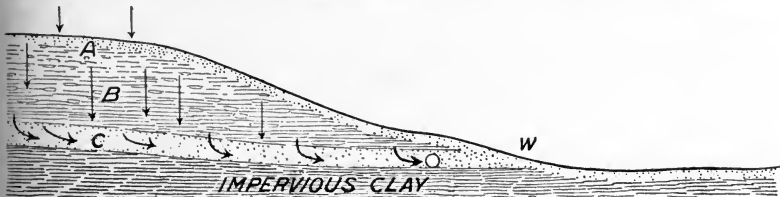

FIG. 39.—Diagram showing difference between percolation and seepage; *A*, the tilled soil; *B*, permeable subsoil through which free water percolates; *C*, sandy gravel substratum through which ground water moves laterally; *W*, area at foot of slope kept wet by seepage of water out from the upland; *O*, place to put tile to catch the seepage water.

for this surplus water to pass down and away, workable soils would soon become unfit for cultivation. It is through percolation largely that soils rid themselves of any free or gravitational water whenever opportunity be given it to flow away.

**Percolation Aided by Roots and Worms.**—Many upland soils are given better drainage through the penetration of roots into the deep subsoil, and through the action of earthworms. When roots of trees and of plants like alfalfa die there remain the openings made by them. These openings, together with those made by earthworms, facilitate percolation. Checks and cracks in the soil also favor this movement of soil water.

**Seepage** is generally understood to mean slow lateral movement of free soil water (Fig. 39). It is common in some localities to observe water seeping out of hillsides. Soils occurring on the borders of marshes are often much wetter than the interior of the marsh, owing to the seepage of free or gravitational water out from the upland.

**Capillary Rise of Water in Soils.**—This is the upward movement of water from the subsoil to the surface. This movement of soil moisture concerns capillary water only. A good illustration of this is the upward movement of water or oil in a lampwick. Suffice it to say that the force which causes this rise of water either in the soil or a lampwick is “capillarity.”

When capillary water rises in soils it does not fill the pore spaces in between the soil particles, but rises or moves from soil grain to soil grain in films which surround the soil particles; thus capillary water may move not only upward, but in all directions, from a greater to a less amount of soil moisture. It is important that the pore spaces do not all become filled with water, because it is through these openings that air enters a soil; and air is one of the factors determining fertility.

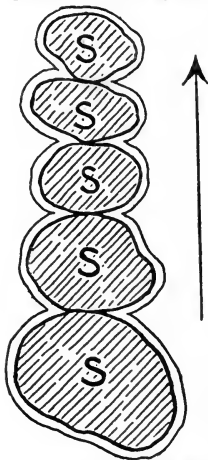

FIG. 40. — Diagram showing how capillary water rises in soils—in films from soil particle to soil particle. S, soil particles.

**Factors Influencing Capillary Rise of Water.**

—There are several factors influencing the rise of water in soils, but we shall consider here only those which are of practical importance to the farmer; viz., soil texture, compactness or firmness of soil, and obstruction.

**Influence of Soil Texture.**—Soil texture has a decided influence on the rise of soil moisture. In a fine textured soil water rises much higher but more slowly than in one of coarse texture (Figs. 40 and 41). Capillary water cannot rise up through gravel or coarse sand; thus a seed bed having a coarse sand subsoil is supplied with no

appreciable amount of moisture from the subsoil through capillarity. A seed bed of silt loam underlaid by silty clay, on the other hand, may be supplied with considerable capillary water from the subsoil to a depth of from four to five feet during a drought. King concluded that moisture may rise in silt loam soils from depths of ten feet in forty-five weeks. Another investigator has shown water to rise in a very heavy soil to a height of only forty-six inches in twenty-eight weeks. Since in a humid climate a drought seldom extends over a period of six weeks, a seed bed of silt loam on silty clay subsoil would probably not secure any moisture from depths greater than four or five feet. Since in most soils in humid climates roots of farm crops extend to depths of three to

four feet, and since moisture can rise to heights of from at least three to five feet in fine textured subsoils below the root zone, it is reasonable to assume that a crop growing on a silt loam having a deep silty clay subsoil draws its moisture supply from six to nine feet of soil during a drought.

**Compactness.**—Compactness or firmness means good contact

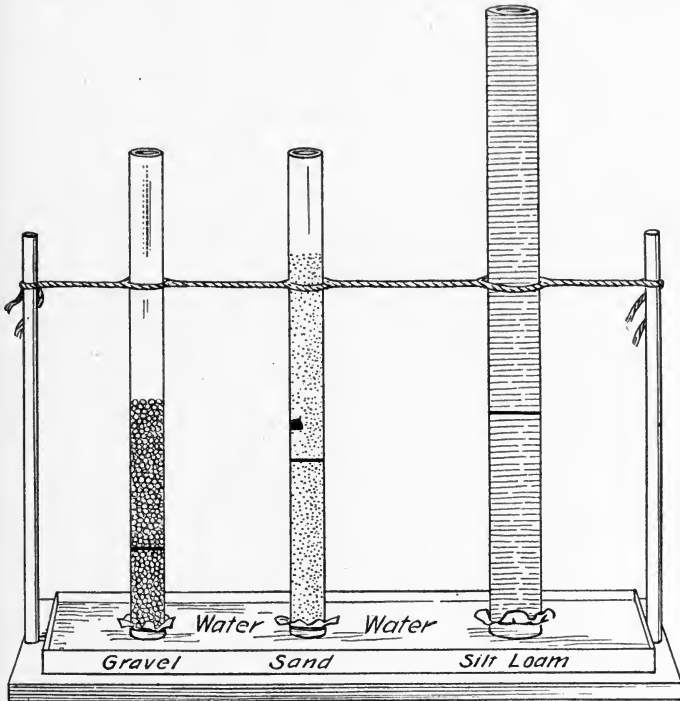

FIG. 41.—Capillary rise of water in soils.

between the soil grains and crumbs within the seed bed. Since capillary rise of water is possible because of the films which extend from soil particle to soil particle, we can readily understand how compactness or good contact between the soil grains facilitates this movement of water.

**Obstruction.**—Under field conditions practically the only obstruction that may at times interfere with the rise of soil water is too much coarse material plowed under; it may be too much coarse manure or litter, a rank growth of clover, or too much

strawy rye. Rye is commonly plowed under to add organic matter to soils. For best results it should be plowed under before it develops stiff straw. In either case cavities are formed which impede or prevent the capillary rise of water from the subsoil to the seed bed. This is especially true when sod is improperly plowed just prior to a dry period. When much coarse litter is to be turned under it is best to plow in the fall, and whenever it is done a short time before planting good contact should be secured, if possible, between the soil and subsoil by working the land and rolling it.

**The Soil a Reservoir.**—In the preceding chapter it was learned that soils act as reservoirs in storing a portion of the water supplied to them and giving it up again to growing crops. Soils vary in this capacity because of differences in texture, content of organic matter and structure. Thus it is that we speak of “water-holding capacity” of soils.

**Water-holding Capacity of Soils.**—Water-holding capacity of a soil is generally understood to mean the greatest amount of water it can retain when all free water is given a chance to drain out. The water thus held includes capillary and hygroscopic moisture, and is expressed in per cent of the dry weight of the soil; for example, if fifty pounds of a perfectly dry soil can hold fifteen pounds of water after allowing all free or gravitational water to drain out, that soil has a water-holding capacity of thirty per cent, the greater portion of it being capillary water.

The following table shows how different soils vary in the amount of water they can hold against gravity:

*Water-holding Capacity of Soils*

Soils	Water-holding capacity (capillary and hygroscopic water) per cent	The equivalent in terms of inches of water in one acre one foot deep *	The approximate amount that crops can use from one acre one foot deep † (Available or capillary water)
A coarse sand.....	15	3.2 inches	3.0 inches
A fine sand.....	22	4.2 inches	3.6 inches
A light colored silt loam.....	30	4.4 inches	2.6 inches
A black silt loam.....	45	6.0 inches	4.0 inches
A well-decomposed peat.....	134	10.2 inches	6.8 inches

\* Obtained by multiplying the weight of soil by the per cent water-holding capacity, and reducing result to inches.

† Roots cannot absorb the last trace of capillary water held in soils, because when the water films become very thin the attraction between the soil grains and the thin films becomes as great or greater than the absorptive power of the roots. The finer the soil the more hygroscopic or unavailable moisture held. Crops may wilt and cease to grow in silt loams and clays when still carrying 12 and 14 per cent moisture, respectively, while they may grow well in coarse sand possessing but 1 to 3 per cent water.

**Moisture Supply Better in Silt Loams Than in Sand.**—Sandy soils give up their water much more easily and completely than silt loams and clays, nevertheless the latter soils generally furnish to crops a much better moisture supply.

The figures in the last column of the table seem to indicate that crops would suffer less for want of water on a coarse sand than on a light colored silt loam during a drought. On the contrary, crops suffer much more on the sand, for two main reasons:

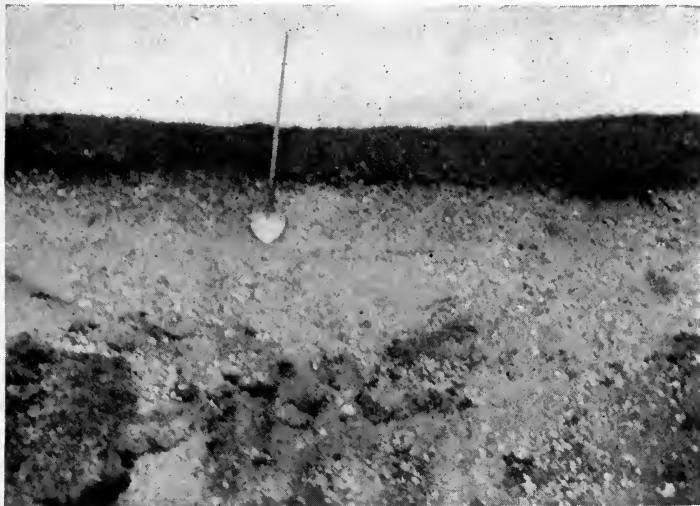

FIG. 42.—A droughty soil. A fine loam about 14 inches deep underlaid by coarse sand and gravel.

(1) Sand gives up its water more easily than silt loam and hence plants are more lavish with it.

(2) In the coarse sand, roots cannot secure moisture by capillarity from depths below the root zone.

Thus it is that corn on sand grows faster than on a silt loam and shows no injury because of lack of rain during the beginning of a dry period, but suffers much for want of water later on as the dry weather continues.

**Some Soils are Droughty.**—Soils which are unable to furnish crops with sufficient moisture during short dry periods are called "droughty"—a deep coarse sand is a good example (Fig. 42). Often the best appearing loam or silt loam proves droughty, because it is underlaid at a shallow depth by a coarse and porous subsoil,

such as coarse sand or gravel. During a dry period the main source of moisture that crops can draw on is the capillary water stored in the shallow surface stratum, since no water is supplied to the seed bed by capillarity from lower depths. Furthermore, roots extending into a gravelly subsoil can secure but little moisture. In contrast to this, a silty clay subsoil, for example, furnishes much water to the seed bed, and to the deep roots extending down into it. Moreover, a seed bed underlaid by a fine textured subsoil can hold more capillary water than if the subsoil were sand or gravel.

In buying a farm it is important to examine into the nature of the subsoil to ascertain whether or not it can furnish the seed bed with any capillary water and supply the deep roots with sufficient moisture; and whether or not it can permit percolation sufficient at least to favor proper drainage.

#### MOISTURE CONSERVATION AND CONTROL, WITH SPECIAL REFERENCE TO HUMID FARMING

The loss of water from rainfall may occur by running off the surface of the soil, by percolating through it, and by evaporating from it. Roughly speaking, only about twenty-five to thirty per cent of the rainfall in a humid climate is used by crops—the rest is lost (Fig. 43). Moisture conservation and control consists (a) in preventing surface run-off as much as possible; (b) in increasing water-holding capacity of soils; (c) in aiding capillary rise of soil moisture; (d) in lessening the loss by evaporation either from the soil or through weeds; (e) in draining wet lands, and (f) in supplying water through irrigation.

**How Run-off May be Lessened.**—Loss of rainfall through surface run-off may be much lessened by aiding soils to catch or trap water. This may be accomplished in several ways: (a) by fall plowing; (b) deep hillside plowing; (c) by loosening up any hard and compact soil and subsoil; (d) by plowing at right angles to the slope or hillside, and (e) by terracing. Any one of these methods permits more of the rainfall to soak into the ground, and that which is not stored or retained by the soil passes on down and away. In some sections, and especially on hillsides, the storage of water by the soil during late fall, winter and early spring, or at any other time, is greatly hindered, because no provision is made whereby soils can catch the rainfall. Any other method whereby soils may be aided in “trapping” and storing water from rainfall is worthy of consideration.

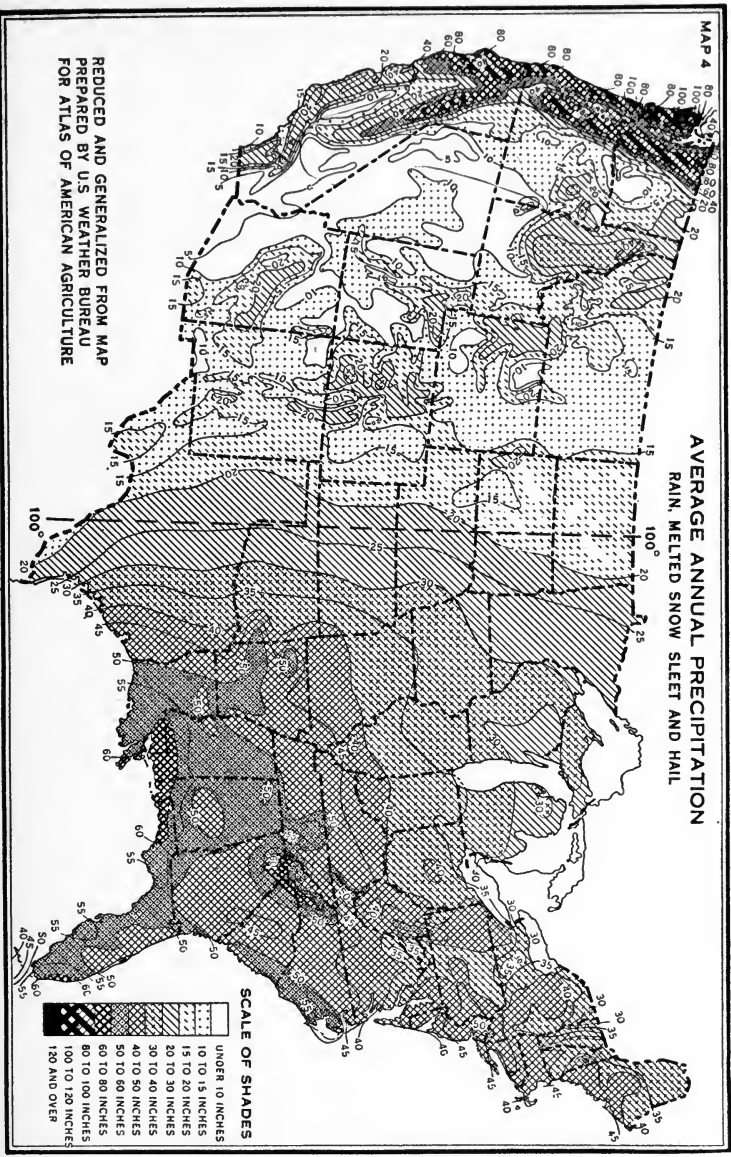

FIG. 43.—The annual distribution of rainfall over the United States. (Dry Farming. Wisdoe. Courtesy Wm. Miller Co.)

**How Water-holding Capacity May Be Increased.**—Since the amount of water retained against gravity by most soils is determined largely by texture, organic matter and structure, it is plainly seen that the water-holding capacity of a sand, for example, cannot be increased by improving its texture. Texture of a sand, or of any soil, remains practically the same, and the structure of a sand cannot be materially changed in a short time. Thus the only course open, in case of sand, is to increase the organic matter.

In case of a "heavier" soil, water-holding capacity may be improved by increasing the organic matter and by loosening it if it is very compact. The addition of organic matter also tends to develop a crummy structure which is favorable to water-holding.

Organic matter may be increased by plowing under clover or green rye, by plowing under a good sod as often as possible, through the application of farm manure and through the application of peat, if convenient.

**Aiding Capillary Rise of Water.**—Good contact between the soil particles favors capillary rise of water. This is an important reason why a firm seed-bed is generally desirable. Not only should the seed bed be firm, but there should also be good contact between the seed bed and the subsoil—in this respect fall plowing is advantageous, also working the land and rolling it.

A seed bed too loose and lacking good contact with the subsoil is not a favorable environment in which to plant seeds, especially if they be small like clover and alfalfa. If frequent rains do not occur when such conditions exist, germination is poor and the crops may be failures.

Special attention should be given to compacting the seed bed when deep plowing is done just before seeding or planting—particularly when the soil is sandy or loamy.

Subsoiling heavy soils to enable them to trap and store more water is to be recommended in some instances, but subsoiling land having sand or sandy subsoil is to be discouraged, since it is desirable to maintain compactness of a sand subsoil to favor capillary rise of soil moisture, to retard loss of water through percolation, and to lessen excessive leaching.

**Lessening Evaporation of Soil Moisture.**—Under field conditions losses through evaporation may be decreased more or less by developing a top layer of loose, dry soil. Such a protective layer is called a "soil mulch" (Fig. 44). A soil mulch may be developed and maintained throughout the growing period only in



fields planted to crops like corn, potatoes, cotton, or any other crop planted in rows so as to permit of intertillage.

**What Constitutes a Good Soil Mulch.**—On silt loams, clay loams and clays a good mulch consists of a layer of loosened and dry soil composed either of crumbs or a mixture of crumbs and small lumps. A dust mulch is undesirable because it becomes a hard crust when a hot sun shines upon it after a rain, whereas a crummy layer does not crust and bake so easily.

A good mulch on sandy soils consists of a loosened and dry layer of sand

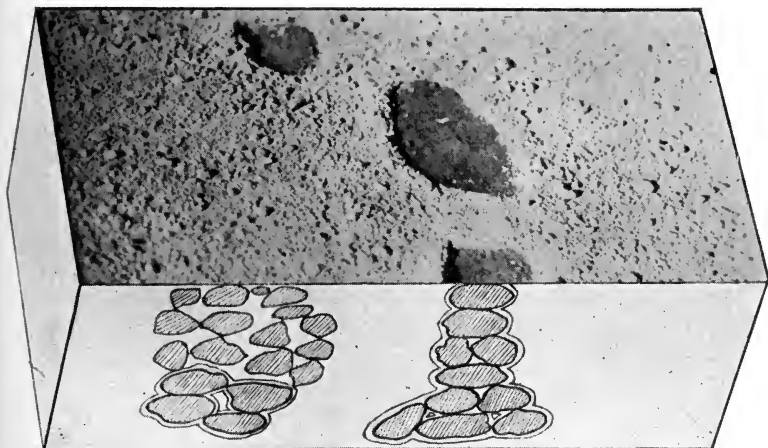

FIG. 44.—How a soil mulch conserves moisture. The footprints are kept moist because the soil moisture is permitted to move to the surface and evaporate. After awhile the footprints will become hard and dry, while the soil beneath the mulch will be mellow and moist.

In a humid climate it is not generally necessary to make a soil mulch deeper than three inches. Many are very effective when only an inch or two in depth, especially in gardens and on heavy soils.

**How a Soil Mulch Conserves Moisture.**—The protective action of a soil mulch in lessening the loss of moisture is based on three principles: (1) The looseness of the soil hinders the movement of capillary water from soil particle to soil particle. (2) The dry surfaces of the soil particles and crumbs offer resistance to the upward movement of water films. (3) A surface layer of dry soil keeps the soil below it somewhat cooler, thus lessening the tendency of the soil moisture to evaporate. When the surface layer of a soil is loosened, therefore, the capillary rise of moisture is

immediately checked, hence the loosened layer soon dries out. When dry, each soil particle and crumb aids in lessening the escape of moisture from below by offering resistance to the rise of the water films (Figs. 40 and 44).

**Cultivation Is Necessary to Maintain Mulch.**—In order to maintain both a loosened and dry condition of a soil mulch it is necessary to rework the ground even though no rain falls, because the loosened layer, owing to its own weight, gradually reestablishes a greater or less degree of compactness which in turn favors capillary rise of film moisture. Rain generally destroys the effectiveness of a soil mulch; so that if the mulch is further desired, it should be reestablished through cultivation (Fig. 44).

**Mulch of Greatest Value During Dry Periods.**—A soil mulch is of the greatest value during dry periods. When frequent rains keep the soil well supplied with moisture the main object of cultivation during such periods is to kill weeds and to aerate the soil, and not so much to establish a mulch to conserve moisture.

Aside from the fact that a mulch conserves moisture, it is important to mention here that heavy soils are much easier to work during dry periods especially, when a mulch is maintained.

**Self-forming Mulches and Protective Crusts.**—Very rapid evaporation causes the surface few inches of a sandy soil, peat or muck to become quickly dried out even though no cultivation be given it, and because of this rapid drying out, the films of soil water become broken, so that the dried surface zone acts as a mulch. This explains why some uncultivated soils lose more water through evaporation in a humid than in a semi-arid climate.

On certain loams and silt loams of crummy structure, self-formed crusts, which break away from the soil beneath, become effective in lessening water losses. These detached crust-like layers vary from a fourth to about two inches in thickness, and are formed as a result of rapid evaporation. Crusts not so loosened from the soil beneath would increase evaporation.

**Mulches of Other Kinds.**—Straw, manure, leaves, grass and other materials are used to a more limited extent for mulching; in many instances to conserve moisture, to keep down weeds, for fertilizing, to avoid soil washing, and in other cases to prevent injury from repeated freezing and thawing during winter and early spring.

**Weeds Are Moisture Robbers.**—The water requirement of weeds is greater than that of corn; thus a growth of weeds in a

crop represents an enormous loss of moisture which should go to the crop (see first table in this chapter). The killing of weeds, therefore, is an important factor in moisture conservation.

**Demonstrations.—Material Needed.**—One balance; a baking-powder can; a piece of cheese cloth; 6 student lamp chimneys, or  $\frac{1}{2}$ -inch glass tubes 12 to 16 inches long; a few pieces of lump sugar (cubes); a few teaspoonfuls of powdered sugar; red ink; a saucer; a few fine needles; some road dust; a piece of dusty board; 2 one-gallon crocks; about a quart each of air-dried loam, fine gravel, coarse sand, fine sand, silt loam; and 8 quarts of loam or silt loam.

**To Make Clear the Meaning of the Three Forms of Soil Water.—Procedure.**—A. Allow the plants in the crock that was kept in the greenhouse (Demonstration No. 4, Chapter V) to dry up and die. Now take out of the crock 100 grams, or about 4 ounces of soil, and dry it at  $105^{\circ}$  C. or  $221^{\circ}$  F. (to prevent burning of organic matter) for 3 to 5 hours. Weigh again and determine the per cent of water contained in the air-dried soil. Most of this water is hygroscopic water.

Plants are wilted and dying in a sand and a clay loam. Which soil contains the more hygroscopic water?

B. Over the perforated bottom of a baking-powder can, or over the opening in a funnel, place a piece of cheese cloth. Fill the can or funnel nearly full of air-dried loam. Pour on the soil a measured amount of water and allow to drain.

**Questions.**—(a) Did all the water drain through the soil?

(b) What is the water called that drained through?

(c) Name the water that was retained by the soil.

**To Observe the Rise of Capillary Water in Soils and to Study Some of the Factors Which Influence This Process.—Procedure.**—Tie some cloth over the lower end of student lamp chimneys, or  $\frac{1}{2}$ -inch glass tubes (Fig. 41). (Tubes should be at least 12 to 18 inches long.) Fill student lamp chimneys or tubes with dry soil as follows:

No. 1.—Fill with dry gravel; tamp well.

No. 2.—Fill with dry coarse sand; tamp well.

No. 3.—Fill with dry fine sand; tamp well.

No. 4.—Fill with dry silt loam; tamp well.

No. 5.—Fill as in No. 3 to within one inch of the top; tamp well. Fill to top with dry, crummy silt loam—do not tamp. (This top layer of loose, dry crummy soil serves as a soil mulch.)

No. 6.—Fill as in No. 3 to within 6 inches of the top; tamp well. Now place on top of this soil column half an inch of cut up straw, dry grass, or hay; then fill to top with dry fine sand—tamp well (see Fig. 40).

Place soil columns in a pan in a vertical position, then pour about half an inch of water into the pan. Observe results at end of 5 minutes; after 1, 2, 3, 4 and 5 days, respectively.

**Questions.**—(a) Why is it necessary to have good contact between the soil particles within the seed bed. Between the soil and subsoil?

(b) What is a droughty soil?

(c) What effect has texture on the capillary rise of water in soils?

**To Demonstrate the Principle of Soil Mulch in Conserving Moisture.—Procedure.**—A. Observe results in tube No. 5, previous experiment.

B. Sprinkle as much powdered sugar on top of a lump (do not press down the powdered sugar) as it will hold, and place the lump in a pool of about 12 drops of red ink poured out on a white dish. Observe results.

The lump of sugar represents soil, and the powdered sugar a soil mulch.

C. Fill a saucer with water; place a perfectly dry, fine needle carefully on the surface film of the water. The needle will float. Why? Take a pinch

of dust and let drop carefully into the water. What happens to the finest, dry particles? Explain. Why do drops of water roll off a dusty board like so many shot?

**To Note the Effect of a Soil Mulch on the Rate of Evaporation from a Silt Loam or Loam.**—*Procedure.*—Fill one gallon crock level full of air-dry silt loam or loam. (In filling establish good contact between the soil particles.) Determine weight of soil in the filled jar. Moisten with water until a good supply of capillary water is held throughout the soil. Weigh again and determine the per cent of capillary water contained in the soil.

Fill a second crock in a similar manner as No. 1, only fill within two inches of the top. Water, and determine the per cent capillary water as in No. 1. Now fill crock to level full with dry, crummy soil (soil mulch).

Place both crocks in a breezy place and determine the per cents of capillary water in the two soils in the two crocks at the end of a week or ten days. Do not water.

Have students record results.

*Questions.*—(a) What constitutes a good soil mulch? On sand? On silt loam?

(b) When is a soil mulch most effective? (Consult text.)

**Laboratory Exercises.**—*Materials Needed.*—Three large and 3 small baking powder cans; some cheese cloth; one 20-mesh screen; one 40-mesh screen; one pie tin; one soil auger; one balance; 4 quarts each of dry coarse sand, fine sand, and a mixture of coarse and fine sand; one quart each of dry crummy silt loam, peat, muck and pulverized peat.

**To Determine the Porosity of Soils.**—*Procedure.*—Punch a hole in the bottom of a baking-powder can. Place a piece of cheese cloth over the bottom on the inside, and fill the can full of dry, coarse sand (screen out all fine material).

Now set the can into a dish of water so that the surface of the soil is about on a level with the surface of the water on the outside. Allow the soil to become saturated so that free water is noticed on the surface of the soil. Place finger over the hole in the bottom of the can, take can out, and allow all free water to drain into another can to be measured. The amount of water in cubic inches represents the amount of pore space in the soil. Determine the per cent of pore space in the coarse sand. ( $\frac{3}{4} \times$  square of radius of soil column  $\times$  height of soil column = cubic inches.) Record results as follows:

Soil	Number cu. in. soil used	Cu. in. water used to saturate soil	Per cent pore space by volume

Repeat the experiment by using a fine sand (screen out all coarse material), and a mixture of coarse and fine sand.

*Questions.*—(a) What is the relation between the size of soil grains and porosity of a soil?

(b) Would the pore space in clay be greater or less than in sand? Why?

(c) How does porosity of a soil affect the rate at which water will percolate through it?

(d) Will dry clay loam weigh more or less than fine sand? Why?

(e) What are the conditions producing the least amount of pore space in a soil? (Note pore space in mixed sand.)

**To Observe the Movement of Capillary Water in Soils.**—*Procedure.*—Pour a cupful of dry sand or loam on a pie tin in a conical pile. Pour about a third of a cupful of water into the tin (not on the pile of soil) and observe results.

*Questions.*—(a) What is meant by capillary movement of soil water?

(b) In what direction does capillary water move in soils? (Consult text.)

(c) What determines the direction of movement?

**To Study the Power of Soils for Holding Capillary Water.**—*Procedure.*—

Fill a small baking-powder can having a perforated bottom, with air-dried, coarse sand. Determine the weight of the soil by subtracting the weight of the can from the weight of can plus the dry soil. Pour water on the soil until thoroughly wet. Allow all free water to drain out, and determine the per cent of capillary water retained. (Use weight of air-dried soil as basis.) Repeat the experiment by using an air-dried, fine sand, a crummy silt loam, and a peat or a muck. Record results in tabulated form.

*Questions.*—(a) Name the factors determining the water-holding power of soils.

(b) Of what importance is the fact that soils can retain moisture? (Consult text.)

**To Determine the Effect of Organic Matter on the Water-holding Power of Soils.**—*Procedure.*—Take a baking-powder can one-half full of the same air-dry, fine sand used in the previous exercise and mix with it an equal volume of pulverized peat, or some other suitable organic matter. Determine the water-holding power of this mixture. (Allow the organic matter to become well soaked before draining off the water.) Compare results with those obtained in the previous experiment.

*Questions.*—(a) What is the effect of organic matter on the per cent of capillary water held?

(b) Does this mixture actually contain more capillary water than the fine sand alone? Determine.

(c) How may the water-holding power of a sand be increased? Of a silt loam?

**To Determine to What Extent Weeds Use Soil Moisture.**—*Procedure.*—

Secure a pint sample of soil (to depth of at least 8 inches with soil auger) from an area in the garden or field where weeds are growing thick and thrifty. Collect a similar sample from another portion of the same field or garden where land has been well cultivated and weeds killed. (Do not collect these samples soon after a rain, but rather near the close of a dry period.) Place these samples in baking-powder cans to prevent drying out. Weigh, and dry at temperature of 105° C. or 221° F. Determine the per cent of moisture in the two samples. (Use weight of soil as collected in field for basis.)

*Question.*—(a) Name several reasons why weeds should be destroyed. (Consult index.)

**Field Studies.**—Determine if possible why some soils dry out so easily.

Observe different conditions which aid soils to trap water.

Observe the effect of a good soil mulch and of any other kind of mulch.

## QUESTIONS

1. What is the relation of moisture to soil fertility?
2. What use do plants make of water? What is the importance of moisture in the soil itself?
3. What can you say concerning the amount of water used by crops?
4. What is meant by "water requirement" of a plant? How do crops differ in this respect?
5. About how much water is lost by evaporating from the soil in growing a crop?
6. What are the factors which influence the water requirement of crops?
7. Tell of the importance of rainfall at the right time during growth.
8. What is dry-land farming? What is the limiting factor of production in this kind of farming?

9. Is moisture ever a limiting factor in production in humid farming? Explain.
10. What is the problem that confronts the dry-land farmer? What is the problem concerning the water supply in humid farming?
11. Name and define the three forms of soil water. Which is of most importance in crop production?
12. How do soils hold capillary water? When can a soil hold its greatest amount of capillary water?
13. Compare a coarse sand with a fine sand in the amount of water it can hold for crop use.
14. Why can a black silt loam hold a large amount of capillary water?
15. What is percolation?
16. What is the relation between percolation and soil erosion?
17. What is the importance of percolation in land drainage? What facilitates percolation under field conditions?
18. What is seepage? Illustrate.
19. What is meant by capillary rise of soil moisture? Give other illustrations of this phenomenon. How does capillary water rise in soils?
20. Name and discuss three factors influencing capillary rise of soil water which farmers should consider.
21. What is meant by water-holding capacity of a soil? How do soils vary in this capacity?
22. What forms of soil moisture does "water-holding capacity" include? Can plants use all the water indicated by "water-holding capacity"? Explain.
23. Compare the available moisture supply a light-colored silt loam can hold with that of a coarse sand.
24. What are "drouthy" soils? What is an important point to consider with respect to subsoil in buying a farm?
25. Mention ways in which water from rainfall may be lost to the crops.
26. Name ways in which moisture may be conserved and controlled.
27. How may surface run-off be lessened?
28. How may the water-holding capacity of soils be increased?
29. How can a farmer aid capillary rise of soil moisture? Why is it best not to subsoil land having sand as subsoil?
30. What is a soil mulch? Under what conditions can it be maintained?
31. What constitutes a good soil mulch in humid farming? In dry-land farming?
32. Explain by use of a diagram how a soil mulch conserves moisture. How may a soil mulch be maintained?
33. When is a soil mulch of greatest value? How does a soil mulch aid cultivation?
34. What are self-forming mulches and "protective crusts"?
35. Explain the uses of straw and other materials used as mulches.
36. What bearing have weeds on moisture conservation?

### PROBLEMS

1. A barrel of water weighs 263 pounds and an acre of water one inch deep weighs 113 tons. How many inches of water are required to grow a 50-bushel oat crop? A 2-ton clover crop? A 5-ton alfalfa crop?
2. If on a certain farm  $\frac{1}{4}$  of the rainfall during the growing period is used by the crops,  $\frac{1}{2}$  is lost by percolation,  $\frac{1}{4}$  lost as surface run-off and  $\frac{1}{4}$  the amount used by the crops is lost through evaporation from the soil, how many inches of rainfall would be required to grow the crops in problem 1?
3. What per cent more water is used by the clover plant in a semi-arid than in a humid climate? Assuming this would apply to alfalfa, about what would be the water requirement of alfalfa in a humid climate?

## CHAPTER IX

### LAND DRAINAGE AND IRRIGATION

THIS chapter may be considered as a continuation of the subject of "Moisture Conservation and Control," which was partly considered in the preceding chapter.

**Land drainage may be defined** as getting rid of free or excess water from wet lands. This subject is a broad one, touching both the field of engineering and of soil management. Because of lack of space, we shall study in this chapter the relation of good drainage to soil fertility, and consider the fundamental principles of land drainage and irrigation.

**Too Much Water is Harmful.**—It is common knowledge that water standing long on a cultivated field either injures or destroys the crop. This injury is largely the result of the shutting out of the air and the checking of the soil activities, because of too much water.

**Other Harmful Effects of Too Much Water.**—Wet soils are cold, and this retards germination and plant growth. Too much water makes fields, or portions of them, unfit for cultivation. Much injury is done poorly drained soils when they are worked too wet. Injury of crops by heaving (through frost action) is greater on wet lands than on those having good drainage. Wet fields which become dry enough to permit of late planting are less profitable than when well drained; moreover, such conditions make crop production uncertain (Fig. 45). It is generally recognized that wet swamp lands are detrimental to public health.

**Benefits of Proper Drainage.**—Many direct benefits are to be derived through proper drainage. The most important are the following:

1. **Soils Warm Up Better.**—Water requires much heat to warm it, and a very great amount to evaporate it.<sup>1</sup> A little of the heat of the sun is absorbed by the water in a wet soil, but the most of it is used up in evaporation. Thus it is that a wet soil is a cold soil (Fig. 46). If the same land were well drained, the heat of the sun would be absorbed by the soil instead.

---

<sup>1</sup> To raise the temperature of a pound of water (1 pint) 1° F., requires 1 British heat unit. To evaporate a pound of water requires 966.6 heat units. It requires no more heat to raise 7 pounds of dry loam one degree than to warm a pound of water one degree.

The free movement of air, possible only in a well-drained soil, aids materially in warming it.

The most effective soil-warming agent is warm rain water. We all know how quickly the dormant vegetation starts growing in early spring when a warm rain sinks into a well-drained soil. Water-logged soils are not benefited in this way by warm rains, because all the rain water is forced to run away as surface water.

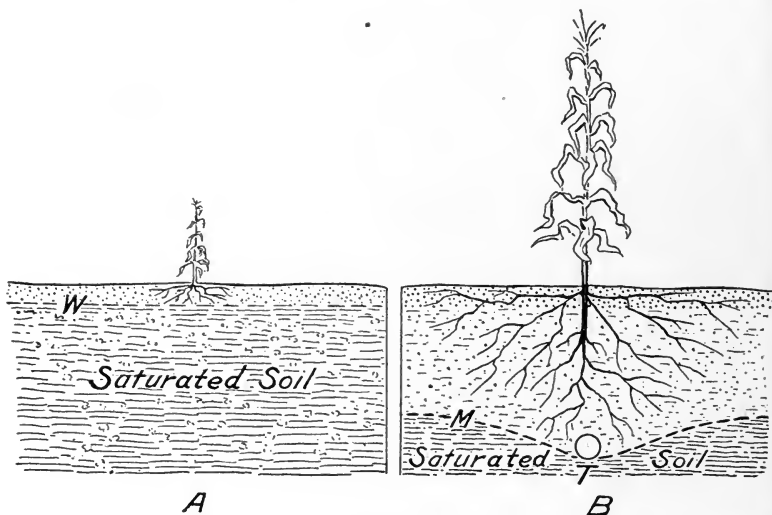

FIG. 45.—A crop on a well-drained soil has a better moisture supply than when planted on a wet soil. *A*, diagram showing root development in a wet soil; *W*, high water-table; *B*, diagram showing root development in the same soil but tile drained; *T*, tile; *M*, lowered water-table. (Page 95.)

**2. Roots Grow Deeper and Stronger.**—Plants growing in soils that are wet or water-soaked develop shallow root systems (Fig. 45). Marsh grasses and tamarack, for example, are shallow rooted. Corn and other crops will not send their roots into a water-soaked subsoil, but will develop them near the surface. Drain a marsh, and the wild grasses and the tamarack die, because the surface soil dries out, and the shallow roots are left without water—capillary rise not being rapid enough to supply sufficient moisture from lower depths. This helps to explain why corn planted on land that is wet during the early growing period suffers for want of water during the summer when the land becomes dry. It seems strange, but it is true, that crops are able to get a better



supply of moisture in a well-drained soil than in a wet one—all on account of more and deeper roots.

Not only are plants able to secure more water when they develop deep roots, but they are able, also, to secure more of the plant-food elements.

**3. Soil Organisms Develop Better.**—Water-soaked soils are practically devoid of helpful organisms, while those well drained are usually abundantly supplied with them (Chapter VII).



FIG. 46.—Wet and cold subsoil injured the corn crop. For many years nobody suspected that seepage water was the cause of poor corn crops on a large portion of this field even though heavy applications of manure were made. To the left, good corn; to right, injured corn. (See Fig. 39.)

**4. Injurious Substances May be Removed.**—Proper drainage may be the means of getting rid of certain injurious substances in soils. In some wet marshes, acids have accumulated to such an extent that the soils have become extremely acid in character. When such soils are drained, the accumulated acids are leached out, sometimes almost completely, during the first three or four years after thorough drainage has been established.

The thorough drainage of alkali spots is the best treatment recommended. Drainage is the method sometimes used to eliminate injurious salts from alkali soils (Chapter IV).

**5. More Plant-food Elements Become Available.**—The entrance of more air in the soil, a warmer soil, the development of

helpful soil organisms, and the growth of more and deeper roots are results of proper drainage, which, in turn, become important factors in making available the plant-food elements. Thus a well-drained soil can perform its functions in relation to plant growth much better than if it were too wet, or water-logged.

**6. Good Drainage Favors Better Farm Management.**—When all the fields on a farm are well drained, the farm can be managed more profitably—cultivation is made easier, square fields are made possible, fields can be laid out to best advantage, seeds can be planted better, crops can be planted earlier and hence are given a longer growing period, fall frosts are delayed, bigger crops can be produced, and farm work in general is not hampered unnecessarily because of wet fields.

**Why Lands are Wet.**—Some depressions on uplands are wet because of lack of surface drainage, coupled with impervious subsoils which prevent the water from soaking away. Some level and fine textured uplands having “tight”<sup>2</sup> subsoils are wet largely because the surface water runs away very slowly. Seepage accounts for many wet areas, both on uplands and lowlands. Many lowlands and uplands are periodically wet because of flood water. Some lowlands are wet because they are so nearly on the same level with streams or bodies of water that the escape of free water is impossible.

**Much Land Needs Drainage.**—There are in the United States a total of about 122,000 sections (square miles) of land unfit for cultivation because of too much moisture, but which could be profitably drained. This is equal to the combined areas of Iowa, Wisconsin, Massachusetts, Connecticut and Rhode Island.

**How Drainage is Accomplished.**—Wet lands can be made dry in different ways, depending largely upon the nature or source of the damaging water.

**1. Surface Drainage.**—Getting rid of surface water is called surface drainage. When the offending water is that which stands on the surface after rains, drainage may be effected by giving it a chance to flow away through furrows or shallow ditches. If the damaging water is that which flows from uplands to lower, and across lower areas, during flood flow, drainage may be accomplished by controlling the course of the water through the use of surface-runs and shallow ditches.

---

<sup>2</sup> A “tight” soil or subsoil is one through which water cannot pass except very slowly.

**2. Subsurface Drainage.**—When the damaging water is in the soil, or when the water-table<sup>3</sup> is too high, “subsurface” or “under-drainage” is necessary. This may be done through the use of open ditches and underground or covered drains.

**3. Vertical Drainage.**—Occasionally water standing in upland depressions and on some flat upland fields may be given a chance to escape by making openings through the tight soil, or subsoil, so that the water may move downward into an open and dry soil below, if such a substratum is to be found.

**4. Combined Methods Necessary.**—It is generally necessary to combine different methods of drainage. On nearly all large areas the best combination for thorough drainage is large open ditches for outlets, and underground drains. Under certain other conditions a surface-run combined with underdrainage gives best



FIG. 47.—Dead furrows as drains. On tight soils, especially on fields having little slope, surface drainage may be had by plowing in narrow “lands” up and down the gentle slopes. The surface water drains from the back furrows to the dead furrows, thence down the dead furrows and off the field. *B*, back furrow; *D*, dead furrow. (See Fig. 68.)

results. In many large areas effective drainage is accomplished only through the combined use of open ditches, underdrains and surface-runs (Figs. 48 and 50).

**Method of Drainage Depends Upon Why Land is Wet.**—The only reasonable and safe way to begin any efforts towards drainage is to ascertain why the land is wet, and this knowledge should determine the manner and system of drainage to be employed. In most cases it is easy to determine when surface drainage is needed; but underdrainage is too often overlooked. On many a field the farmer never suspects a lack of sufficient drainage to be the cause of low crop yields.

To eliminate any guessing in ascertaining the need of subsurface drainage, dig a post hole about four or five feet deep, preferably during seeding time or when the ground seems too wet and cold to work; and if, when the hole is left open, the water comes within three feet of the surface, the land is in need of underdrainage. Many grasses make good growth on land satu-

<sup>3</sup> The surface of the free water, or ground water, in a soil, is called the “ground water-table.” When the free water comes near the surface, the ground water-table is said to be high.

rated with water to within three feet or even eighteen inches of the surface. Most farm crops, however, do best when such lands are thoroughly drained.

**Use of Spade May be All That is Necessary.**—Frequently water standing in a cropped field may be gotten rid of by spading a shallow trench to some drain or roadside ditch. Sometimes the placing of a galvanized steel culvert under a road-bed, or the mere lowering of such a culvert, is all that is necessary to enable the water to escape, or to prevent its backing up on the land.

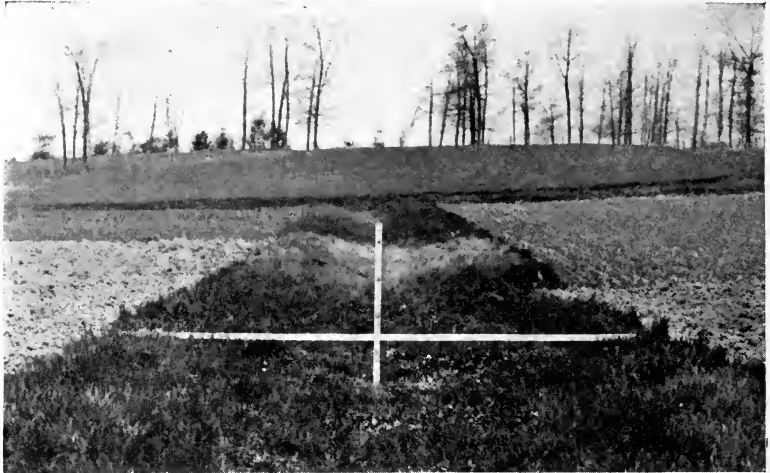

FIG. 48.—A well-sodded surface-run. The grass prevents soil washing. (Wisconsin Station.)

**Plow Furrows as Drains.**—On tight soils, and where fields have little slope, water from rainfall causes much injury because of insufficient natural surface drainage. The plowing of these fields in narrow strips of about four rods wide up and down the gentle slopes often provides good surface drainage. When this method is practiced, the “back furrows” should form slight elevations running lengthwise through the middle of each plowed strip, and the “dead furrows” should be kept open. In this manner the water from rains or melting snow drains from the back furrows to the dead furrows, thence down the dead furrows and off the field (Fig. 47).

**Surface-run a Necessary Drain.**—A surface-run is a shallow low runway for water—about one and one-half feet deep and ten

feet wide at the top (Fig. 48). It is used to remove surface water during heavy rains and melting snows. Such a run may be conveniently used to protect depressions, and to prevent surface water from entering a lower area. These drains should be kept well sodded. As a rule a drainage system is not complete unless surface-runs are provided to take care of the excess water during flood flow.

**Open Ditches.**—Frequently small open ditches about 3 to 5 feet deep are employed, in place of surface-runs, to prevent flood water from flowing on to low lands; the water is thus carried around the low area or to one side instead.

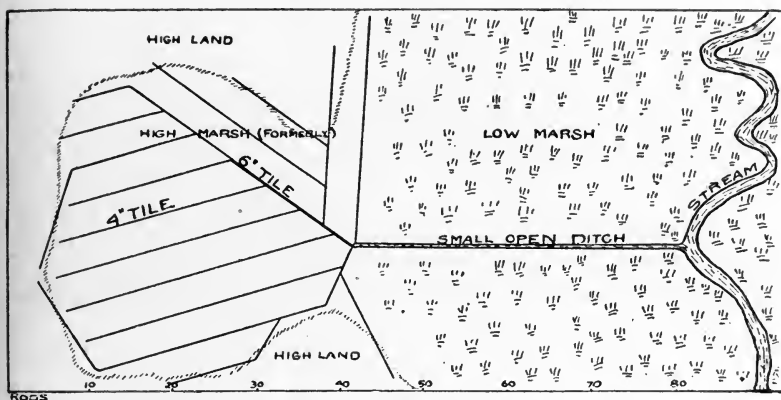

FIG. 49.—A small open ditch properly located. This serves as a makeshift outlet for the tile system until the bed of the stream is lowered by a dredge. (Wisconsin Station.)

A small open ditch about four feet deep and seven feet wide at the top is sometimes dug through a low marsh kept wet by a sluggish stream, to serve as a temporary outlet for a system of tile or underdrainage, until the stream is lowered and straightened by a dredge (Fig. 49).

Open ditches of considerable width and depth are employed in large marshes where much water is to be removed and where the fall is slight. Such ditches are of primary importance because they form the outlets. They are dug by means of dredges. In many marshes having winding and sluggish streams these ditches are made by straightening and deepening the water-courses.

On extensive marshes large open ditches, or canals, are constructed every mile or half-mile, with large tile at regular intervals in between them.

Good open ditches do not afford complete underdrainage except for a few yards on either side of them. In order to secure thorough underdrainage through the use of open ditches, they must



FIG. 50.—A good outlet ditch. This was dug with a floating dredge. It is 20 feet wide at the top and 7 feet deep. (Wisconsin Station.)

be dug about every four or eight rods; but many open ditches take up considerable space, they cut farms and fields into inconvenient and irregular shapes, they require the building of many

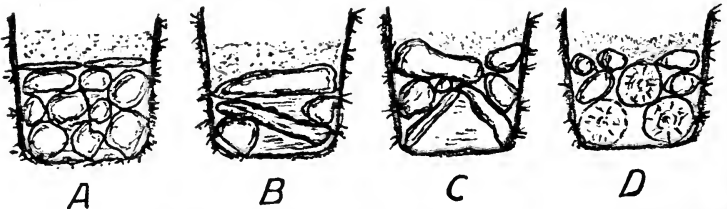

FIG. 51.—Covered drains other than tile. *A, B, C*, cobblestone and rock drains; *D*, pole drain.

farm bridges, they are unsightly, they are difficult and expensive to keep open and clean, they present a constant source of danger to farm animals, they provide harborage for obnoxious weeds, and are excellent breeding places for injurious and disagreeable insects.

**Covered Drains.**—The only way to eliminate the objections to many small open ditches is to use covered drains, among which may be mentioned tile drains, cobblestone drains, rock drains and pole drains (Fig. 51). Cobblestone, rock and pole drains are not commonly used, except in certain localities where these materials are available. They are usually of short duration, because they become easily clogged. The universal covered or under-drain is tile, and because of its importance, it shall be given special consideration.

#### TILE DRAINAGE

**Drain Tile.**—Drain tile are pipes usually of circular form from one to two feet long and varying in diameter from three to thirty inches (inside measurements). Most drain tile are made of burnt clay; some are made of cement. When well made, tile are very durable. Clay tile have been in operation on a farm in New York since 1837; and in France some have been in use 200 years and more.

**How Tile Are Laid.**—(Fig. 52). Drain tile are laid end to end in narrow trenches and covered. A drain constructed by placing tile end to end in a trench is called a "line of tile." It is quite necessary that they be laid deep enough to escape tillage tools, to give deep underdrainage, and to escape freezing, if possible. In clay the usual depth is three feet, in sandy soils four and one-half feet. Occasionally conditions do not permit their being laid more than about two or two and one-half feet deep. In peat and muck soils tile should be laid especially deep (four and one-half feet and more), because these soils settle rapidly after they are tile drained. On some marshes the settling of the peat brought the tile so near the surface that they had to be taken up and laid deeper.

The size of the tile to use depends upon the amount of water to be removed. It is a safe rule to follow not to use smaller than five-inch tile.

The digging of a trench for a line of tile is always begun at the outlet, and it is generally necessary to lay the tile as soon as the bottom of the trench is made ready, although it is better to finish the trench and start laying the tile at the upper end, or head.

**Tile Drains Must Have Fall.**—Every line of tile should be so laid that water entering it at any point will flow to the outlet. This descent or fall of a line of tile is called the "gradient." It is

desirable to have a gradual fall of three inches in 100 feet if possible. On flat areas, one and one-quarter inches, which is considered the minimum grade, is frequently used. It is important to remember that the less the fall or gradient, the bigger should be the tile.

When a good fall is apparent, it is comparatively easy to lay tile so that they will carry off the water properly. On level ground however, much care should be exercised in securing sufficient fall.

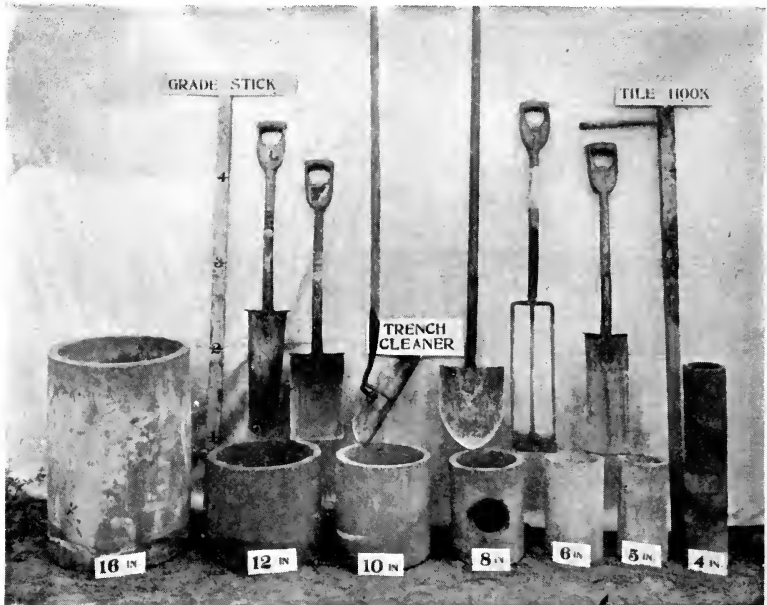

FIG. 52.—Samples of drain tile and the necessary tools used in constructing systems of tile drainage. (Wisconsin Station.)

The level is the common instrument used in determining the amount of fall.

Some experienced tilers determine the grade by the flow of the water in the trench before the tile are laid.

Tile may be properly laid on a level area through the use of grade lath (Fig. 53). For example, a line of tile 600 feet long is to be laid, and it can be given a depth of four and one-half feet at the outlet. To give this line a fall of two inches in 100 feet the tile must be laid three and one-half feet deep at the upper end of the line. Two stakes (*a*, *b*) are driven about three and one-half



feet apart, one on either side of the proposed trench at the outlet, and a lath (*c*) is nailed to them horizontally one foot from the ground (from top of lath), which would be five and one-half feet from the proposed grade line (*O, X*), or the bottom of the trench. Two other stakes (*d, e*) are driven in a similar manner at the upper end, and a lath (*f*) is nailed to these two feet from the ground, which would likewise be five and one-half feet from the grade line. Other pairs of stakes are driven in line with the first ones at intervals of about 100 feet and to them lath are nailed horizontally and in line of sight over the top of the laths "*(c)*" and "*(f)*." The trench is now dug until the top of a stick five and one-half feet long held vertically on the bottom of the trench is in line with the top of the laths. In this way a perfect grade can be obtained,

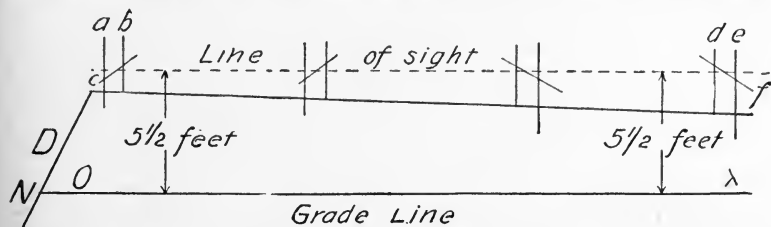

FIG. 53.—The use of grade lath in laying of tile. *D*, outlet ditch; *N*, proposed outlet for tile; *O, X*, proposed grade line. (See page 117.)

because the line of sight over the laths is parallel to the proposed grade line.

On extended flat areas it is necessary to lay tile deep at the outlet and shallow at the upper end, in order to secure sufficient fall.

On all large areas, especially if they are level or nearly so, it is best to secure the services of a competent drainage engineer to lay out the system of drainage and to supervise its construction.

**Covering the Tile.**—As soon as the tile are laid, sufficient amount of soil should be shoveled in to cover them, and to hold them in place until the trench is filled. Covering and anchoring the tile in this manner is called "blinding."

Filling the trench may be done by hand, or by the use of a plow or a scraper.

**Distance Apart to Lay Lines of Tile.**—Frequently a single line of tile is all that is necessary to drain a narrow wet strip. In draining a narrow, wet depression (draw) between two areas of high land, it is often best to lay two lines of tile, one at the foot of each slope, or one on each side of the lowest center line. On all

broad, flat areas several lines of tile are necessary. Just how far apart these drains should be placed to secure adequate drainage depends largely on the character of the subsoil. In some very heavy soils and in springy areas, it is necessary to lay them not more than two rods apart, while in porous and open soils they may be placed as far apart as eight to twelve rods. In ordinary loams and silt loams, and in peat and muck, four rods is the common distance.

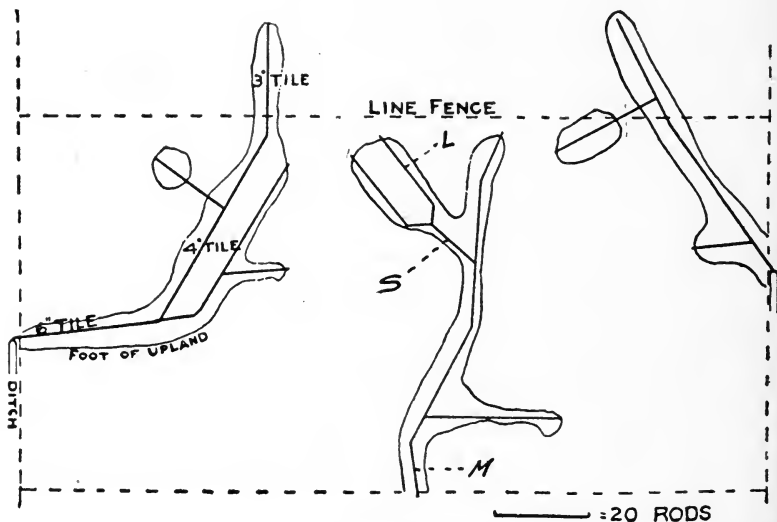

FIG. 54.—Natural systems of tile drainage. Three systems in an 80-acre field. *M*, main; *L*, lateral; *S*, sub-main. (Wisconsin Station.)

**How Tile Works.**—Water gets into tile drains through the joints between the tile (Fig. 59). In case of porous tile, a little water goes through the walls, but at least ninety-five per cent enters through the joints. Care should be taken in laying tile not to leave cracks between them so big as to permit soil to fall in, yet not so close together as to exclude the water. In tight clays it is well to “blind” the tile with black soil to facilitate the entrance of water. In sand it is necessary to blind the tile with black soil to keep the sand from entering.

It is a mistake to think that thorough underdrainage is harmful to crops, particularly in dry seasons. Tile cannot “draw” water out of soil, nor can they drain a soil too thoroughly. It is impos-

sible to remove the capillary, or the useful water, by tiling; it is only the free or harmful water that is drained out. Tile may drain somewhat deeper than the depth they are laid. The capillary rise of water may cause the water-table to drop below the tile. Drainage during the wet period may cause the water-table to drop lower during the dry period than it would if no water had been removed. The deeper root development encouraged by early drainage compensates for this apparent loss.

**Systems of Tile Drainage.**—A tile system simply means the arrangement of the lines of tile designed to drain any particular area. Usually tile systems are made up of “mains,” “laterals”

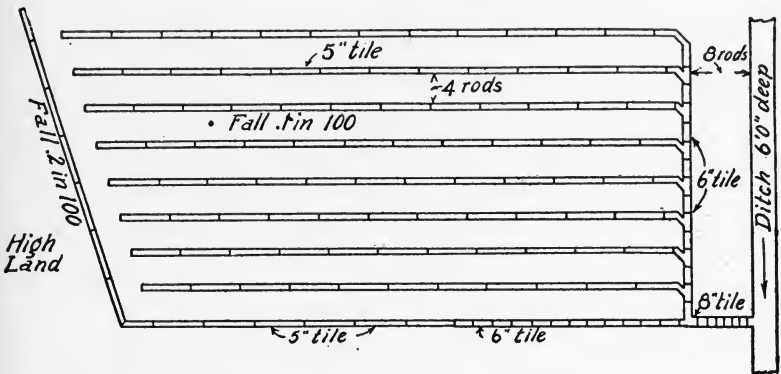

FIG. 55.—The gridiron or parallel system of tile drainage. Troublesome outlets are avoided by having several laterals discharge into a single main. A line of tile is located at the edge of the high land to cut off seepage. (Wisconsin Station.)

and “sub-mains” (Fig. 54). A main carries and discharges the water from an entire system. A lateral is a single branch drain into which no other line of tile discharges. One or several laterals may discharge into a “sub-main” which, in turn, empties into a main.

The water of the areas to be drained and the slope of the land necessarily call for different systems of tile drainage, of which four are generally recognized—the “natural” system, the “gridiron” or “parallel” system, the “herringbone” system and a “combination” of two or all three of these systems.

**1. The Natural System.**—When an irregular area is to be drained, the laterals and sub-mains have varying directions, and they must necessarily join the main in an irregular manner (Fig. 54). This is called the “natural” system.

**2. The Gridiron or Parallel System.**—When an area requiring several lines of tile slopes uniformly in one direction, or when it slopes uniformly towards two adjacent sides, the “gridiron” or “parallel” system is the most economical (Fig. 55). This system may also be used on level areas.

**3. The Herringbone System.**—Sometimes land slopes towards a middle and lower area. In such a case the “herringbone” system is most convenient (Fig. 56). This system may likewise be employed on level areas.

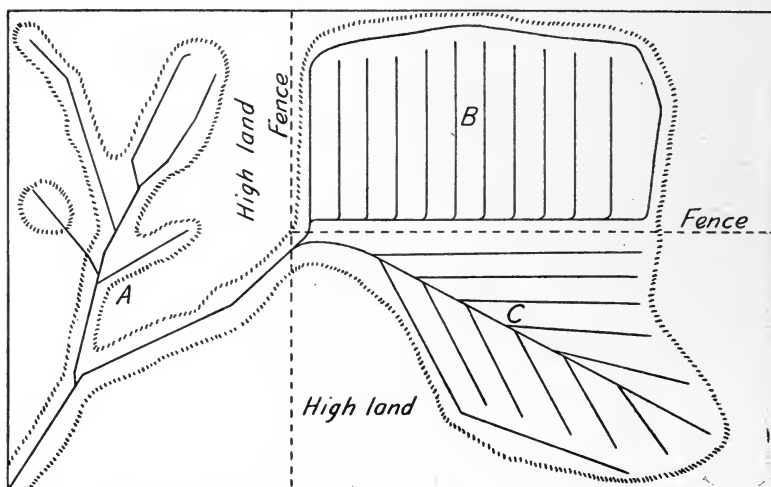

FIG. 56.—A combination of three systems of tile drainage. A, natural system; B, parallel system; C, herringbone system.

**4. Combination of Systems.**—In actual practice it is usually necessary and convenient to combine the different systems of drainage, since conditions vary even in comparatively small areas. Figure 56 illustrates this.

**Outlets of Mains Should be Protected.**—Exposed outlets of mains should be constructed to withstand frost, flooding or washing and tramping of livestock. Moreover, they should be protected by a screen to prevent their becoming clogged by anything that might enter the mouth of the drains. Generally, it is best to use glazed sewer pipe for about six to ten feet at the outlet, laid in firm soil, or imbedded in concrete (Figs. 57 and 58).

**Tile Cheaper and Better Than Open Ditches.**—In the long run

it is best and less expensive to drain with tile than with open ditches whenever possible. With a few exceptions, an open ditch smaller than six feet deep, three feet wide at the bottom, and fifteen



FIG. 57.—The two protected outlets to the drainage system on this marsh of 125 acres  
Two steel pipes screened by iron rods.

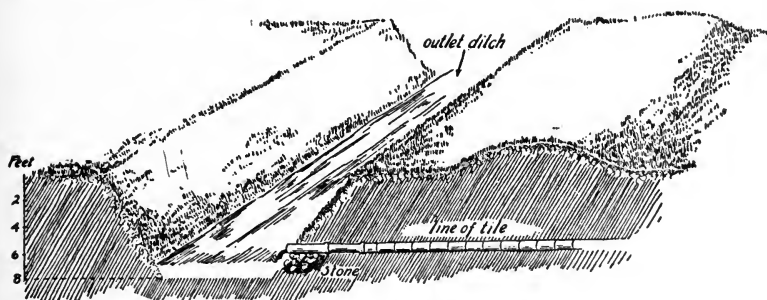

FIG. 58.—An open ditch should be deep enough to permit tile to empty into it. With few exceptions, an open ditch smaller than six feet deep, three feet wide at the bottom, and fifteen feet wide at the top, has no excuse for an existence. (Wisconsin Station.)

feet wide at the top, has no excuse for an existence; large tile should be used instead, or a surface-run combined with tile will work best.

**Tile Combined With a Surface-Run.**—In constructing this

combination it is usually better to make the surface-run at one side of the tile after the tile is laid and when the land is dried sufficiently to permit horses to work (Fig. 59). When completed, the surface-run carries the water during flood flow, while the tile works throughout the year.

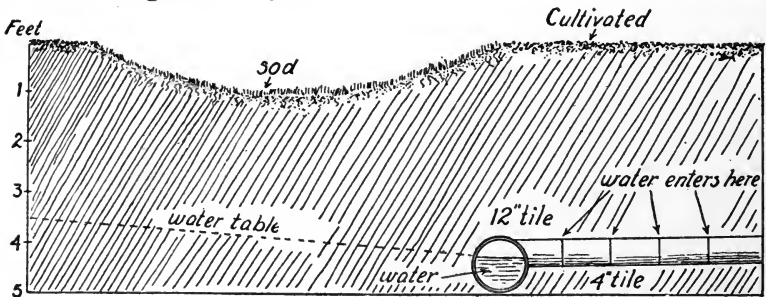

FIG. 59.—Tile combined with surface-run. The surface-run carries the water when there is a flood, while the tile works throughout the year. (Wisconsin Station.)

**Tile Drainage is Profitable.**—(Figs. 60 and 61.) It costs from twenty to forty-five dollars an acre for complete tiling, but the benefits to be derived far exceed the cost, as is shown by the four typical examples in the following table:

*Cost and Benefits of Tile Drainage*

Acres	Conditions before drainage	Cost of drainage	Conditions after drainage
90	A 60-acre field was poor pasture, and a 30-acre field was cultivated, but most of the crops failed	\$2,200	Pasture improved 300 per cent. The 30-acre field now grows six times the amount of grain as formerly, and no failures
16	Was worthless for pasturing and cultivation	\$ 700	Fine corn, clover and other crops are now produced
40	Grew willow brush	\$1,000	Now grows most excellent corn
240	Land was of little value for pasture, and it produced no hay	\$2,360	Splendid crops of hay and grain have been raised since drainage. The value of one crop offsets cost of tiling

**Vertical Drains.**—Some vertical drains consist of openings or cracks in underlying bed-rock, and cracks or openings made in hard-pan<sup>4</sup> by the use of dynamite. It sometimes happens that a

<sup>4</sup> A hard and impervious substratum is commonly called a hard-pan. It may vary in thickness from a few inches to three feet and more.

sinkhole, or a cavern in the underground rock, affords a splendid outlet for a system of tile drainage.



FIG. 60.—Can any good thing come out of this marsh full of brush, cat-tails, reeds, and rushes? (See Fig. 61.)



FIG. 61.—Corn that will fill the silo to good measure has been grown on the same marsh as shown in Figure 60, after being properly drained.

Now and then a drilled well, or one dug and filled with stones, furnishes the only possible means whereby water in basins can be drained out. Not all wells made for such a purpose prove successful—this one may fill with water, while another may bring to

the surface even more water. The successful ones never fill, no matter how much water may drain into them.

The most common vertical drains consist of ordinary drain tile placed in the ground vertically, end on end (Fig. 62). It should be remembered that the only conditions under which such a drain can work are: first, a porous or gravelly stratum should underlie the

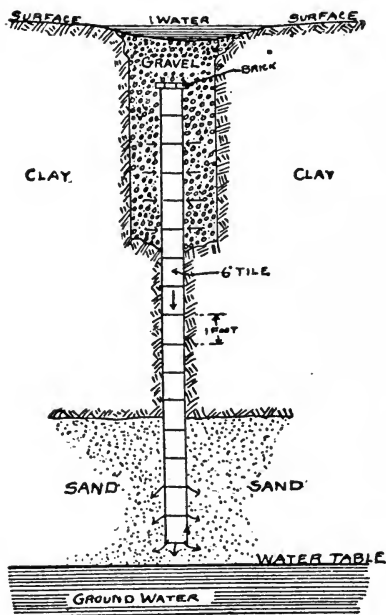

FIG. 62.—A vertical drain. A porous or gravelly stratum should underlie the impervious hard-pan or subsoil, and the water must have a chance to flow away. (Wis. Station.)

this lake was fifteen feet deep and covered about sixty-five square miles. Now this area, formerly a lake, is traversed by well-improved highways and is occupied by about 20,000 people. In a similar manner the Dutch Government (1913) authorized the undertaking of the complete reclamation of about 781 square miles of what is now the southerly portion of the Zuider Zee.

#### IRRIGATION

**Irrigation Is the Artificial Watering of Land.**—It is the opposite of land drainage. Irrigation is commonly thought of as a practice

impervious hard-pan or subsoil; and, second, that stratum should be dry so that the drainage water may flow away.

**Drainage by Means of Pumps.**—The drainage of many low-lying lands is made possible only through the use of pumping machinery to lift the drainage water over levees into adjacent streams or other drainage channels. The drainage of such areas is done by open ditches and tile—but all the drainage water discharges into reservoirs, and from them it is pumped over the levees. This kind of drainage, though successful in a number of the European countries, is but little developed in the United States.

One of the most interesting pumping drainage projects known is the great Haarlem Lake of Holland. Until 1852,



confined to dry regions, but this is not necessarily the case. In arid climates, irrigation is absolutely necessary to produce any crops at all, while in semi-arid sections, irrigation, where possible, makes crop production sure, and greatly increases the yield. In sub-humid and even in humid regions, because of the irregularities in the time and amount of rainfall, irrigation is practiced to a greater or less extent. Both China and Japan, for example, have a large and a well distributed rainfall, yet irrigation is generally



FIG. 63.—Furrow irrigation in orchard in dry climate. (U. S. D. A.)

practiced. In Japan alone, water is artificially applied to at least 12,500 square miles of land, or about two-thirds of her cultivated area.<sup>5</sup>

**Objects of Irrigation.**—The primary object of irrigation is to supply needed water to crops. Without irrigation, many thousands of square miles of land in the world would be deserts instead of fit places to live in; and hundreds of square miles of desert wastes are today being made to produce bountiful harvests just by supplying water to these thirsty lands.

In the United States irrigation is confined largely to the western states, where many large irrigation projects are in operation or

<sup>5</sup> "In China and Japan, where they must raise large crops or starve, they have been compelled to irrigate, although they have a larger summer rainfall than we . . . but they also fertilize heavily."—King.

under construction, bringing under cultivation millions of acres. According to the Thirteenth Census, there are in all about 14,000,000 acres of irrigated land in the continental United States (Fig. 63).

Irrigation or flooding proves beneficial and necessary in growing certain crops, such as rice and cranberries.

On irrigated lands flooding is extensively used to moisten fields preparatory to plowing; and flooding, instead of tillage tools, is frequently employed to firm a seed bed prior to planting.

In some sections irrigation is extensively practiced, supplementing a good and evenly distributed rainfall, to make highly fertilized lands produce the highest possible yields. This is especially true in densely populated countries, like China, for example.

In some places irrigation is the means whereby fertilizing material is carried to the land—sewage from great cities like Paris and Edinburgh, for example. In several countries the water of rivers is used to fertilize meadows, and, in most cases, to supply needed water at the same time.

**How Irrigation Water is Secured.**—Before any area of land can be irrigated a source of water must be provided. The most common sources are rivers. In such cases, a portion of the river water is diverted and conducted by means of canals, conduits and huge pipe lines to the area to be reclaimed, where it is turned from the main canal to branch canals which carry the water to the farms to be irrigated, to which it is delivered by still smaller branches. It is interesting to read about or to see some of the wonderful engineering feats accomplished in some of the great western irrigation projects (Fig. 64).

Other sources of irrigation water are lakes, large reservoirs made by constructing dams across gorges or narrow valleys, and flowing wells. Water may also be secured by pumping it from wells, streams and canals.

**How Irrigation Water is Applied.**—There are four ways in which irrigation water may be applied to land—by flooding, through the use of furrows, by spraying, and by subsurface irrigation. Flooding and the furrow method are the two approved methods of irrigation in irrigated sections. Whichever method is used depends upon the character of the soil, the lay of the land, the kind of crops, the water supply, and the “head,” or the volume of water supplied to the unit of time. Under some systems of irrigation management, farmers are given large streams of water for short

times, and under other systems, they are given small streams for longer periods.

1. **Flooding.**—Flooding is a method of surface irrigation. The water applied covers the whole surface of a field either as a thin sheet of running water, continued until sufficient water has soaked into the ground, or as a sheet of standing water which is allowed to remain until the soil has absorbed enough. Flooding is usually practiced when the land is not too sloping and when irrigation



FIG. 64.—Roosevelt Dam, Salt River, Arizona. One of the big dams of the world. Date of construction, 1905-11. Approximate cost, \$10,000,000. Used to irrigate 219,000 acres. (U. S. Reclamation Service.)

water is abundant. It is commonly done on fields cropped to small grains, alfalfa, and grasses.

2. **Furrow Irrigation.**—Furrow irrigation is a second method of surface watering. By this method the water is guided over the land in furrows, or channels, which traverse the whole field—the water covering only a part of the soil surface. Furrow irrigation is one of the most common methods, and is one of the best for all conditions. When crops like potatoes, corn sorghum and sugar beets are grown, it is usually best to irrigate by the furrow method after the crop is on the ground. This is also the commonly adopted method of all orchard irrigation (Fig. 63).

3. **Spray Irrigation.**—Spray irrigation is the process of applying water to the surface of soils or to crops in the form of small drops, spray or mist. The first systems of spray irrigation were the outgrowth of city lawn and garden sprinkling. It was soon found that through such spraying, small amounts of water could be applied advantageously to delicate crops, especially for supplementing an uncertain rainfall.

The water used is conveyed to the field under pressure through pipes or hose. This system of irrigation is well adapted to those conditions in humid sections which demand small and frequent



FIG. 65.—The Skinner system of irrigation. A field piped for overhead spray irrigation. (U. S. D. A.)

applications of water in the preparation of the soil for transplanting, and for supplying quick-growing, market-garden crops and berries with the moisture they so much need for best growth, and especially to keep them thriving during dry periods (Fig. 65).

4. **Sub-irrigation.**—Underground or subsurface irrigation implies that the irrigation water is applied from below the surface. This may be accomplished through the use of open ditches and underground tile, or pipes of iron, concrete, or wood.

The open ditch method of sub-irrigation has proved successful to a limited extent in western America and in Florida.

The underground pipe system of irrigation has not met with success, except under exacting soil conditions found in only a few localities. At Sanford, Florida, the same tile used in sub-irrigation also serves for drainage during wet seasons.

**Irrigated Farms Require Good Management.**—Farms in irrigated sections require cultivation and good management as do farms in humid regions. It has been found that cultivation after irrigation is very effective in conserving the soil moisture. Weed control is another important consideration. The diversification of crops on individual farms and in each irrigation section, and the production of livestock, should be given careful attention—not only to utilize labor effectively, but to help maintain soil fertility.

**Many Irrigated Lands Need Drainage.**—At first thought it seems strange, especially to one unfamiliar with irrigation conditions, that irrigated lands should need drainage. Nevertheless, some areas, either directly or indirectly, have been converted into swamps by irrigation; other areas have become water-logged and are unproductive; still other irrigated lands have passed from a state of high productivity to a condition fit only for wet pastures. Often the result of over-irrigation is manifested in an accumulation of alkali salts on or near the surface without any apparent wet condition. Other areas not irrigated also require drainage. Deep underdrainage is necessary and is the only possible means whereby these lands may be reclaimed.

Aside from the objects sought in draining any soil, the thorough underdrainage of some of these irrigated lands has an important additional object; and that is, to provide an outlet for the downward moving water used to dissolve out the harmful alkali salts. For irrigated areas, drains of clay or shale tile are the best. The tile should be hard-burned, impervious, and free from foreign ingredients so they can withstand the harmful action of the alkali salts.

**Other Irrigation Problems.**—Irrigation farming has many features quite different from farming without irrigation. Aside from the problem of water supply, application of water, and the other problems already mentioned, there are many others that an irrigation farmer must either solve for himself or have solved for him. These problems relate to the best methods of irrigation under particular conditions, to the economic use of water, to the amount of water best for different crops, time best to apply water, frequency of application, the maintenance of soil fertility, etc. Much information on these points is available, but lack of space here prohibits further discussion.

**Profits in Irrigation Farming.**—It costs more to produce crops

under irrigation than under rainfall. It follows, therefore, that the farmer's profits must be less with irrigation than without, unless the yields are larger or the prices he receives for his produce are higher. The prosperity of some of the irrigated sections of the West has been more largely due to increases in the value of land than to the profits in growing crops. This may also be said of many sections in humid regions.

According to some investigations made on irrigated farms in Utah and in an irrigated section in Montana, the average farmer's labor income<sup>6</sup> on these farms seems to compare favorably with the average labor income received by farmers of other states.

**Irrigation an Art of Antiquity.**—When we learn of the advancements that have already been made in reclaiming arid lands in the United States, and of the almost magic transformations resulting from irrigation, we cannot but wonder at it all, and comment on the wonderful age in which we are living. Yet, when we consider the remains of canals and certain other ruins of ancient lands, including what is now Southwest United States—ruins which give us but a glimpse of the elaborate systems of irrigation operated by ancient and prehistoric peoples—we reflect the same sentiment expressed nearly three thousand years ago by that wise oriental king—"There is no new thing under the sun." The art of irrigation has thus come down to us as a prehistoric heritage to be improved by succeeding generations.

**Demonstrational Exercises.**—*Material Needed.*—2 large baking-powder cans; 2 cubic feet of sandy soil; a thermometer; 3 three-inch clay tile; 2 10 × 12 × 10-inch wooden boxes.

**To Demonstrate That a Warm, Spring Rain Warms a Well-drained Soil Quickly, While a Saturated Soil Remains Cold.**—*Procedure.*—Fill 2 large baking-powder cans within one-quarter inch of the top with a sandy soil. One can should be water tight and the other should have the bottom perforated. Saturate and flood the one soil with cold water. Bring the other soil to the same temperature by passing cold water through it. Determine the temperature of the two soils. Now pour on each soil at least one-half a pint of warm water. (The warm water will pass through the drained soil but will run off the other.) Take temperature readings again and record results.

*Questions.*—(a) Explain why warm spring rains do not warm saturated soils.

(b) Why do warm rains warm cold well-drained soils most effectively?

(c) Name other benefits of good underdrainage.

---

<sup>6</sup> In comparing the profitableness of different systems of farm management or in determining the profits in farming, the farmer's "labor" or "managerial income" is the most convenient and accurate basis. Labor or managerial income means profits above total costs—total costs including interest on money invested and unpaid family labor.

**To Demonstrate How Tile Works.**—*Procedure.*—Obtain three 3-inch clay or shale tile and two water-tight wooden boxes about 10 × 12 × 10 inches. Cut two holes in each box in opposite sides near the bottom, large enough to allow the tile to enter. Place one tile in the first box so that the two ends will project from either side. Place the other two tile end to end, with the joint in the middle of the box and the ends of the tile projecting from opposite sides of the box. Make both boxes water-tight by means of paraffin or paint (do not seal the joint between the tile in the box containing the two tile) and fill each box with sandy soil. Saturate the soil in both boxes with water and note results.

*Questions.*—(a) How do tile work under field conditions?

(b) Are there any objections to the use of glazed tile?

(c) About what per cent of the drainage water passes through the walls of the tile?

**Laboratory Exercises** (optional).—*Material Needed.*—Ditching spade; tile hook; a number of tile; a few laths; a drainage level; and whatever other tools found necessary.

**To Construct a Trench for Drain Tile.**—The teacher can determine the method of procedure.

**To Become Familiar With a Drainage Level.**—The teacher should determine the need of such an exercise, and plan sufficient work to meet the needs.

**Field Studies.**—Observe wet areas, especially those due to seepage. Note the conditions of the subsoil.

Observe any system of drainage: open ditches, systems of tile drainage, outlet, results, benefits, etc.

QUESTIONS

1. What is meant by land drainage?
2. Why do crops suffer when water stands too long on a field?
3. Name other harmful effects of the lack of drainage.
4. Name and discuss the benefits of thorough drainage.
5. Give reasons why some lands are wet.
6. Discuss the need of land drainage in the United States.
7. How may wet lands be drained? Describe briefly the different methods, and conditions under which used.
8. What is the first step in draining land? How may this information be obtained?
9. What can be done with a spade in land drainage?
10. How can plow furrows serve as drains? Illustrate by a diagram or sketch.
11. What is a surface-run? What is its use and how made?
12. Explain the uses of open ditches in land drainage.
13. What are the objections in constructing many small ditches? How can these objections be overcome?
14. What is meant by tile drainage? What are drain tile?
15. How are tile laid, and how deep?
16. What is meant by "line of tile"? Gradient? What relation is there between gradient and the size of tile to use?
17. How may the grade line be determined in digging the trench for tile? Explain by use of diagram the use of grade lath.
18. What is meant by "blinding" tile?
19. How far apart should lines of tile be laid?

20. Explain why it is often best to lay two lines of tile in a wet draw between two areas of upland.
21. How do tile work? Can land be too thoroughly drained? Explain.
22. Explain and illustrate by use of a diagram what is meant by a system of tile drainage, mains, laterals, and sub-mains.
23. What are the systems of tile drainage commonly used? Illustrate each by diagram.
24. Why is it best to have one instead of many outlets to a system of tile drainage?
25. What is the smallest ditch that should, under most conditions, be constructed? Explain.
26. Is drainage profitable? Give an example.
27. What are vertical drains? Describe by use of a diagram the conditions under which a vertical tile drain can work.
28. How is it possible to drain low-lying and flooded lands?
29. Describe a drainage system which you have seen installed.
30. What is the meaning of irrigation? To what kind of climate is irrigation confined?
31. Give the objects of irrigation.
32. What are some of the sources of irrigation water?
33. Name and describe the methods of irrigation.
34. Do irrigated farms require less attention than farms not irrigated?
35. Why do some irrigated lands need drainage?
36. What are some of the special problems that confront the irrigation farmer?
37. Is irrigation farming profitable?
38. Who invented the art of irrigation?
39. Describe an irrigation system which you have seen.



## CHAPTER X

### TILTH AND TILLAGE

FROM earliest times it has been the experience of husbandmen that cultivated plants grow best in soils that are stirred or tilled. In this modern age good tilth, good seed bed and intertillage are especially emphasized as important factors in successful crop-production. Good tilth is one of the factors determining fertility; and it has been defined as that physical condition of the seed bed with respect to mellowness and firmness that is favorable to plant growth (Chapter V). This condition is developed largely through tillage. A good seed bed is not merely a layer of very loose, fine soil; it consists, rather, of the tilled portion of the ground, loosened and pulverized until it is mellow, and at the same time possessing a fair degree of firmness (Fig. 66). The proper preparation of the seed bed is fundamentally important in securing good yields of practically all farm crops; and, in case of crops planted in rows, subsequent cultivation, or intertillage, is indispensable.

**Factors Determining Good Tilth.**—The development of good tilth, or of a good seed bed, depends largely upon three factors: (1) the moisture content of the soil when worked; (2) soil structure, and (3) the kind of tillage tools used.

Any one who has ever operated a tillage tool knows that soils pulverize and work best when they contain a proper amount of moisture. Each farmer must determine for himself just when the soils on his farm are in fit condition to work.

The easy workability of soils of a sandy and crummy structure is well known. Heavy soils of compact structure require the most attention and effort to get them into good tilth. The crummy structure of the heavier soils depends largely upon the amount of organic matter they contain, since the organic matter binds the soil particles into crumbs or granules. It is a common experience with some farmers that certain soils are much more difficult to work and pulverize now than years ago, for the reason that the organic matter has been largely removed or used up, and too little attention was given to maintain or increase it through the growth of grasses and clover, and through the use of manure. The frequent growing of grasses and clover on heavy lands greatly aids

in changing the structure of such soils, because the fine roots and other organic matter prevent the individual grains from running together. This explains why sod ground and some black, crummy soils can be plowed when quite wet without any appreciable harm. When the roots and organic matter are used up, the soil loses its acquired looseness and crumbly characteristic. Even sandy soils till better when they contain a good supply of organic matter. Because of its influence on soil structure and on tillage, the organic



FIG. 66.—An excellent seed bed prepared for alfalfa.

matter of soils should be maintained, and in many soils, increased if possible.

**Tillage Tools.**—Numerous kinds of implements have been devised to prepare the ground for planting, and especially to care for many of the crops during early growth. There are many different kinds of plows, harrows, rollers, clod crushers, weeders and cultivators. Aside from these there are many seeding and planting implements which in themselves perform various tillage operations in addition to sowing the seed.

Frequently the real purpose of a tillage implement, or the principle upon which it is built, is overlooked; and too often a machine is purchased merely because of some new device, or some extra lever, rather than on the quality of the work it can do, or

because of its adaptability to the soil in which it is to be used. It should be remembered that every good implement is designed to do a certain kind of work, and, in most cases, in a particular way; and each one is built with certain adjustments so that it can be regulated to meet varying conditions.

**The "How" of Tillage Depends Upon the "Why."**—When the specific objects of tillage are kept in mind, and the principles governing the methods of tillage are clearly understood, there can be little difficulty in deciding upon the kinds and types of machines to use, and when best to operate them.

**The Objects of Tillage.**—The objects of tillage are: to loosen and pulverize the soil, to deepen the seed bed, to crush lumps and break crusts, to turn under coarse litter and vegetation, to compact the seed bed, to kill weeds, to enable soils to catch and thus store more moisture, to conserve soil moisture, and to mix fertilizers and other materials into the soil. Two or more of these objects may be accomplished in one operation.

**Principles Governing Tillage.**—Some of the principles governing tillage may be stated as follows:

(a) A mellow and firm seed bed is necessary to favor germination, and to enable young plants to develop good, strong root systems.

(b) The liberation of plant-food elements through the action of organisms and other agencies is favored when soils are well aerated. Aside from drainage, tillage promotes the exchange of air in soils.

(c) The fact that capillary water in soils rises from soil particle to soil particle makes it necessary that the soil particles within the seed bed and between the seed bed and the subsoil be in close contact with each other (Chapter V).

(d) Since soil moisture readily evaporates when the surface soil is firm and compact, it is essential that a soil mulch be developed, wherever necessary and practicable, to check or lessen this loss of moisture (Chapter VIII).

(e) Heavy, compact soils can be made to trap and thus store more moisture when they are loosened, plowed or subsoiled.

(f) The natural, crummy structure of the heavier soils may be easily destroyed when they are worked too wet. This creates a "puddled" condition which is unfavorable to plant growth.

(g) Weeds should be destroyed.

In the following paragraphs these objects and principles are

considered in relation to the different tillage implements. It is convenient to divide the discussion into three parts: (1) Preparation of the seed bed; (2) seeding and planting, and (3) cultivation and intertillage.

#### PREPARING THE SEED BED

**The Plow the First Implement.**—The first tool commonly used in the preparation of the seed bed is the plow. Because of its importance, it has been called the greatest tool in the advancement of agriculture. Long before the invention of the modern plow, tillers of the ground so fully realized the great necessity of some kind of implement to loosen the soil preparatory to planting

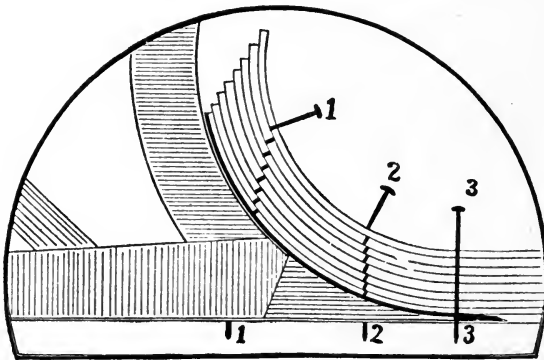

FIG. 67.—Diagram illustrating the pulverizing action of the moldboard. (King.)

that many of them used a crooked, wooden stick. A modern moldboard plow is a comparatively plain tool and seems a simple invention, yet the history of its evolution reads like a romance.

Because of its ingeniously devised steel moldboard, the modern plow can turn practically any kind of soil, and at the same time pulverize it more or less (Figs. 67 and 68). Certain equipment is required to increase the efficiency of the plow; such as, jointers and coulters, to cut sod into strips so it can be turned and to aid in turning under weeds, grass and litter; the gauge wheel, to aid in regulating the depth of plowing; and clevises, for draft adjustments (Figs. 69 to 74).

**Plowing Stubble Land.**—Stubble land, or old ground, is land on which small grains and cultivated crops have been grown. Plows designed for such lands are called stubble plows. Their moldboards are short, high and have an abrupt turn. Because of



FIG. 68.—The work of the plow. The center of this plowed area is the back furrow.

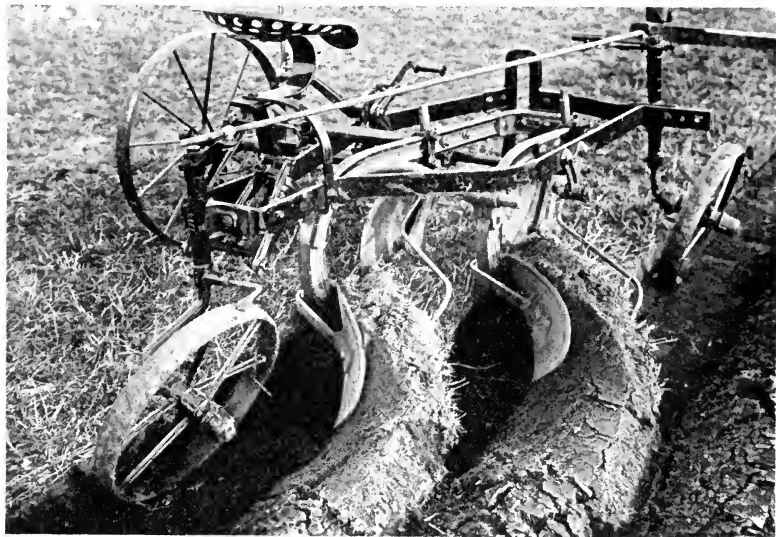

FIG. 69.—The way a good plow does its work. When one becomes interested in the action of the plow, plowing ceases to be a drudgery.

this type of moldboard, the soil is thoroughly pulverized when turned—provided it is in fit condition to be plowed (Figs. 71 and 72-1).

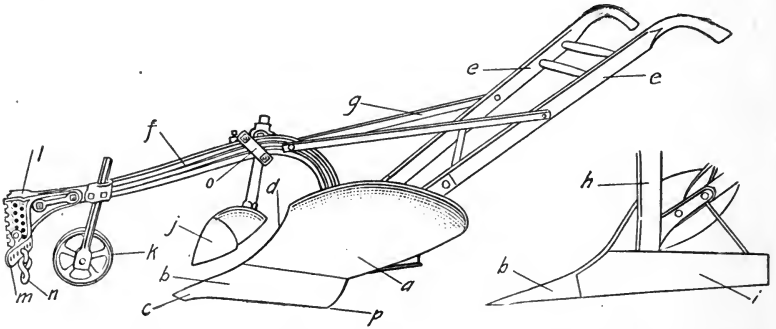

FIG. 70.—The parts of a plow: *a*, moldboard; *b*, share; *c*, point; *d*, shin; *e*, handles; *f*, beam; *g*, brace rods; *h*, standard; *i*, landside; *j*, jointer; *k*, gauge wheel; *l*, bridle; *m*, beam clevis; *n*, hitch clevis; *o*, clamp; *p*, heel.



FIG. 71.—First prize stubble plowing.

**Plowing Sod.**—The only way to turn a prairie sod, or any old, tough, grass sod, is to use a prairie-breaker type of plow (Figs. 72 and 79). This type is built with an easy-turning moldboard which turns the furrow slice over flat, against the preceding one

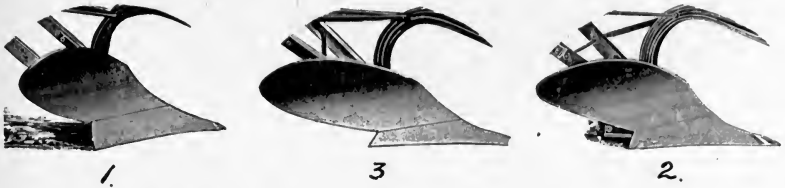

FIG. 72.—Three types of plow bottoms: 1, stubble bottom; 2, general purpose; 3, sod.

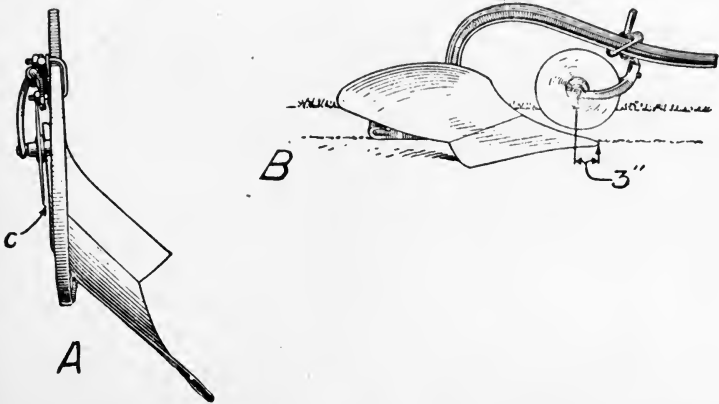

FIG. 73.—Adjustment of coulters. *A*, ordinarily set coulters one-half inch from landside (*c*). In deep plowing or for sod one-quarter inch. Secure a full furrow slice to keep shin covered with dirt. *B*, set middle of rolling coulters about three inches back from point. In loose or trashy soils, one or two inches back. In hard or sticky soils, about four inches back.

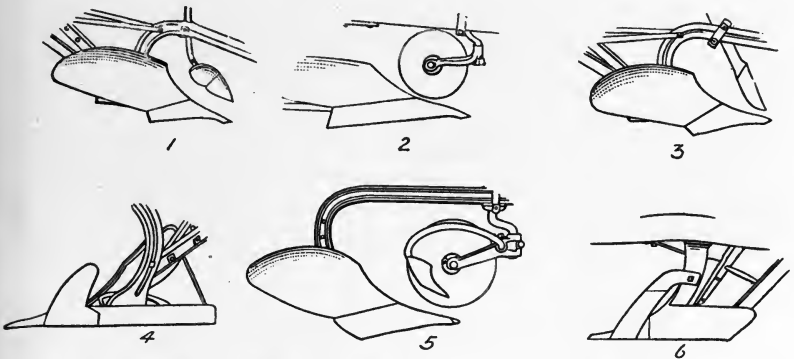

FIG. 74.—Different types of coulters and jointers. Note proper adjustment. 1, jointer; 2, rolling coulters; 3, blade coulters or hanging cutters; 4, fin coulters or cutters; 5, combination rolling coulters and jointers; 6, knee cutters or coulters.

without breaking it very much, and in a way which facilitates the decomposition of the sod.

Ordinary sod is turned best with a sod plow, or one having a moldboard adapted for either sod or stubble (Figs. 72 and 78). The moldboards of such plows are somewhat longer, and turn the

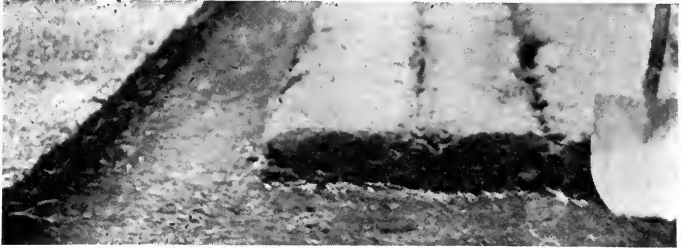

FIG. 75.—Wrong way of plowing sod. (Humid farming.)

furrow slice more slowly than those of the stubble plows. Sod turned properly is much more easily made into a good seed bed than when poorly or improperly plowed (Figs. 75, 76 and 77). A stubble plow, under average conditions, cannot turn sod the way it should be turned (Figs. 78 and 79. Compare with Fig. 77).

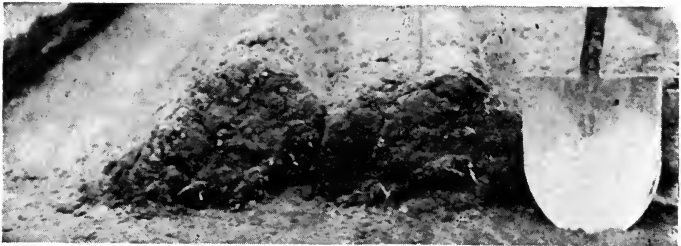

FIG. 76.—Right way of plowing sod. (Humid farming.)

**When Disk Plows Are Used.**—Some soils, because of their condition or peculiar characteristics, can be plowed successfully only with a disk plow; these are dry and hard, sticky, waxy or gumbo soils, and other soils in which a moldboard plow will not scour<sup>1</sup> (Fig. 80). The disk plow may be used on stubble land when the depth of plowing is five or more inches. It is not recommended for

<sup>1</sup> Moldboards, disks, cultivator shovels, drill shoes and hoes should always be kept clean and free from rust when not in use. Most farmers use axle grease to keep them from rusting. Frequently plows refuse to scour simply because their moldboards were allowed to rust.





FIG. 77.—What happens when sod is plowed with a stubble plow.



FIG. 78.—First prize sod plowing.  
It is not so tiring, sir, to plow well,  
For your mind is interested. (English Plowman.)

sod or light, loose soils when it is desirable to plow less than five inches deep. The moldboard plow is recognized as a universal plow. The disk plow is brought into service only when the mold-

board plow cannot be used. The disk plow may be used successfully in plowing loose peat soils.

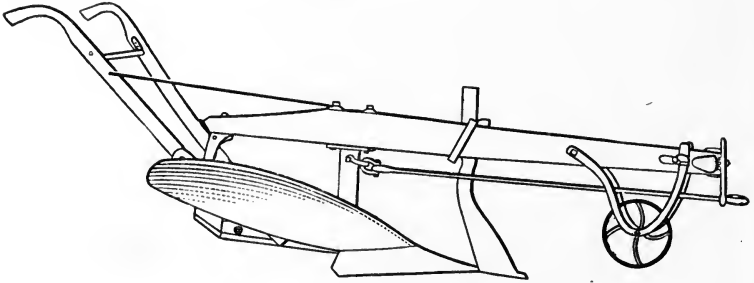

FIG. 79.—A prairie breaker.

**Best Time to Plow.**—The best time to plow depends largely upon the object to be attained. Since nearly all plowing is done in the fall and spring, it would be well to consider here a few important points concerning fall and spring plowing.

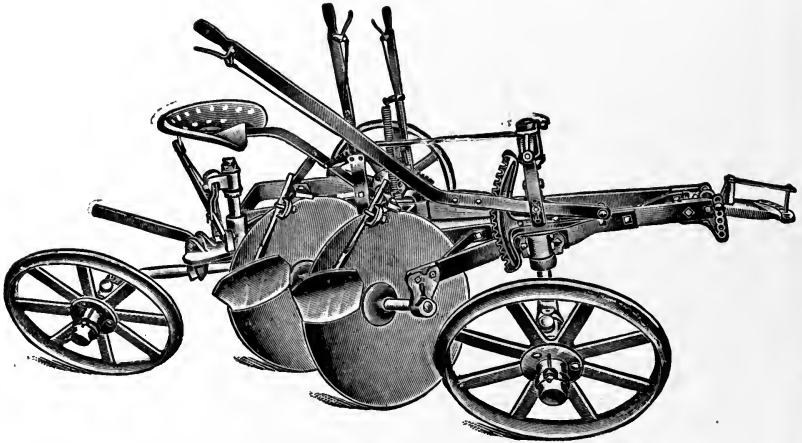

FIG. 80.—One type of disk plow.

**Fall Plowing.**—Usually farmers find it convenient to plow in the late fall, because farm work then is not so pressing as in other seasons; moreover, the congestion of work in the spring is much relieved when the plowing is done at this time. When soils are to be plowed deeply, or when the seed bed is to be deepened, late

fall plowing is best. This results in less loss of nitrogen through leaching, and in the development of a firm seed bed. Furthermore,

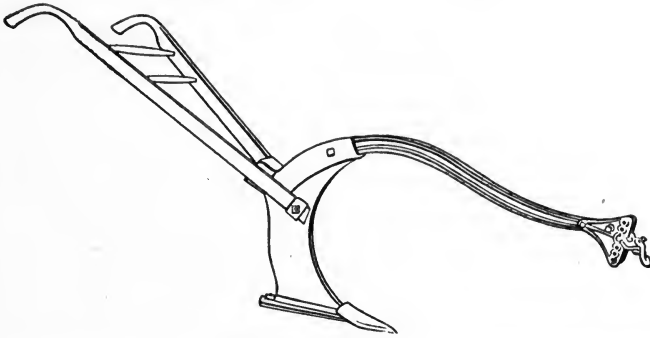

FIG. 81.—Subsoil plow.



FIG. 82.—A subsoil plow in action.



FIG. 83.—The work of a subsoil plow.

when any "raw" subsoil is turned up, it becomes thoroughly weathered before planting time.

Other advantages of late fall plowing are: (a) It favors the development of granular or crummy structure, and hence good tilth, in lumpy and heavy soils; (b) many crop pests are destroyed, such as white grubs and aphids; (c) coarse litter turned under is permitted to decompose partially, thus establishing better contact between the seed bed and the subsoil, and providing a better supply of available plant-food elements; (d) soils plowed in the fall are seldom too wet.

Fall plowing is usually best for wheat, and is commonly practiced when corn follows sod.

In dry-farming sections it is often best to plow immediately after a grain crop is harvested; for two main reasons: (a) the soil plows better because of the moisture it contains, and (b) soil moisture is conserved.

In some sections farmers hesitate to plow much of their "young" sod land in the fall, because if they do, they may be left without any hay land the next season if, perchance, the new or spring seeding is winter-killed.

Land that is fall plowed should be left rough, unless it is plowed early and sown to a cover crop or winter grain.

**Spring Plowing.**—Usually much plowing is done in the spring, largely because time does not permit all of it to be done in the fall. At this time of the year there is much danger of plowing some of the heavier soils when too wet. This is harmful, because the crummy structure of the soil is destroyed, and a "puddled" condition results. This explains why some heavy silt loams, clay loams and clays are so hard and lumpy. A puddled soil is not necessarily mud. When a wet clay, for example, is worked, the crumbs, if any, are broken up and the soil particles run together, forming an impervious mass; in other words, the clay is puddled. On drying the mass becomes hard. The action of the plow is sufficient to produce a puddling effect when a heavy soil is plowed too wet.

Spring plowing is best for sands that are subject to "blowing."

Late spring plowing permits the plowing under, for soil improvement, of green crops which ordinarily do not make sufficient growth in the fall to turn under at that time. Rye is a good example.

**Moderately Deep Plowing Best.**—In general, best results are secured when soils are plowed moderately deep—from six to nine inches. In a deep seed bed most plants develop deep, strong root systems, thus enabling them to secure a good supply of moisture

and plant-food elements. On deep, rich soils deep plowing is not absolutely necessary. On the better soils it is not necessary to plow deep for small grains—three to four inches is usually better than six inches. On the poorer soils fall plowing to a depth of six inches for grain is often more desirable than shallow spring plowing. For corn, and especially for the sugar beet, a deep seed bed is to be preferred.

Deep hillside plowing is frequently recommended for fields that wash easily (Fig. 84). This causes much of the rainfall to soak into the ground, thus checking or lessening the run-off. All hillside plowing should be done at right angles to or across the slope.

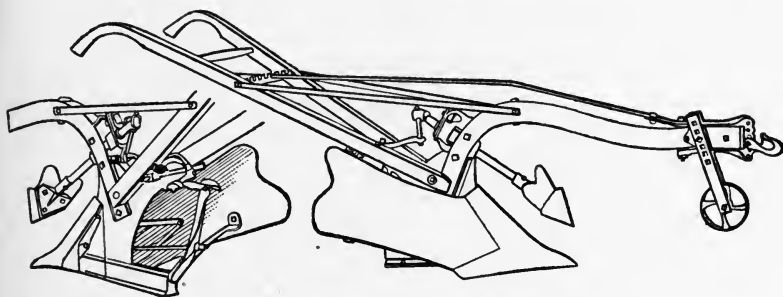

FIG. 84.—Hillside plow. (Walking type.)

New or virgin lands seem to produce best when initial plowing is comparatively shallow. Since in such soils the helpful soil organisms necessarily inhabit a shallow surface zone, too deep plowing buries them so deep that they cannot properly perform their function in making plant-food elements available.

It is good farm practice to vary the depth of plowing from year to year. If a soil is always plowed at the same depth, the tramping of the horses and the weight of the plow on the furrow bottom tend to compact and harden it, causing the formation of a so-called "plow-sole." This danger is greatest in wet clay soils. A plow-sole is detrimental because it retards or prevents percolation, entrance of air and root penetration.

**Subsoiling and Deep Tilling.**—Plows have been built to stir the soil at greater depths than can be accomplished by the common plow. These implements are called subsoilers and deep-tillers (Figs. 81, 82 and 83). A subsoil plow is used when the subsoil is so compact that water and roots cannot penetrate it. This imple-

ment follows the common plow, and cuts a thin, deep gash in the bottom of the furrow; thus loosening the subsoil without mixing it with the surface soil. Subsoiling is not a general practice in humid farming, since results do not seem to warrant the extra expense, except under unusual conditions. The subsoiler should never be used in light, sandy loams, sand or gravelly soils.

Deep tilling through the use of other plows designed for this purpose generally do not give the returns above the extra cost to encourage this practice.



FIG. 85.—“Striking out a land” with a two-bottom gang plow.

**Dynamiting Soils.**—Dynamite has been used in some places to break up and loosen impervious subsoils to facilitate the entrance of air, water and roots. Though it proves a good practice, when necessary in tree planting, its general use is still an open question.<sup>2</sup>

**More About Plows and Plowing.**—Special plows are designed for hillside plowing (Fig. 84). The bottoms of the walking types swivel for right- and left-hand furrows, and the sulky types consist

<sup>2</sup> Subsoiling, deep tilling, and soil dynamiting are all operations that increase the expense of production over that of ordinary plowing. Experiments conducted in both dry-land and humid farming all lead to the conclusion that yields cannot be increased nor the effect of drought overcome by tillage below the depth of ordinary plowing.—*Jour. Agril. Research*, Sept. 9, 1918.

of two bottoms, a right-hand and a left-hand plow. The use of these plows enables the operator to work back and forth across the field, throwing the furrow slices all the same way. He ascends the hill as he progresses and leaves no back furrows (Fig. 86) or dead furrows.

While the walking plow is still used by many farmers, the sulky type is coming into general favor. With its modern improvements the sulky plow lessens the draft, is simple to operate, and saves the strength of the operator.



FIG. 86.—The first round. The back furrow.

The gang plow is also becoming a common implement (Fig. 85). With such a plow one man can operate two or more bottoms, and it can be drawn with horses or a light tractor. This helps to solve the labor problem. The three-bottom gang is a common light-tractor plow, though on the smaller farms the two-bottom gang is usually preferred. On large prairies, where immense tracts are farmed, ten, twelve and fourteen-bottom, large-engine plows have been in use (Figs. 87 and 88).

**Plowing Does Not Make a Seed Bed.**—Seldom can a seed bed be properly prepared through plowing only—other tillage operations are necessary, depending on the condition of the plowed ground, the kind of crops to be grown, and the method of fertilization.

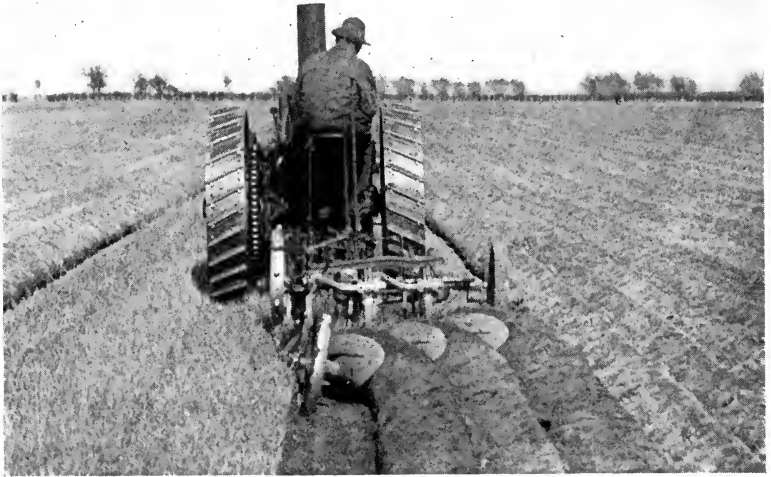

FIG. 87.—A three-bottom tractor plow at work.

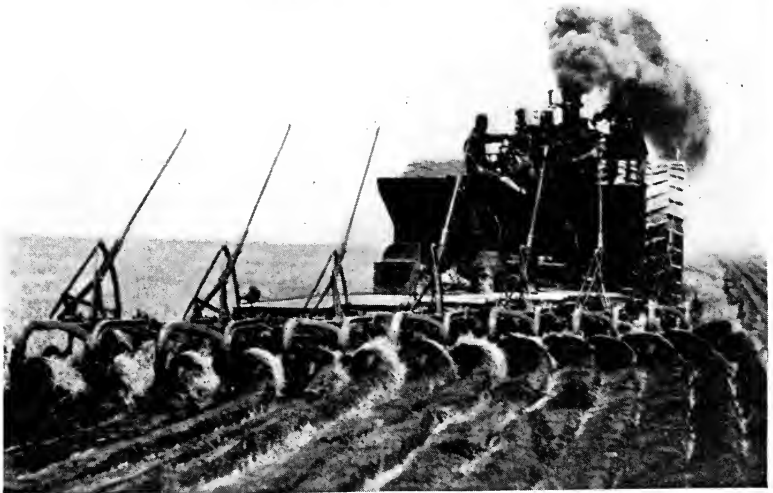

FIG. 88.—A 14-bottom big engine plow in action.



Just what to do to complete the preparation of the seed bed depends largely upon how clearly the farmer understands what constitutes a good seed bed, or good tilth.

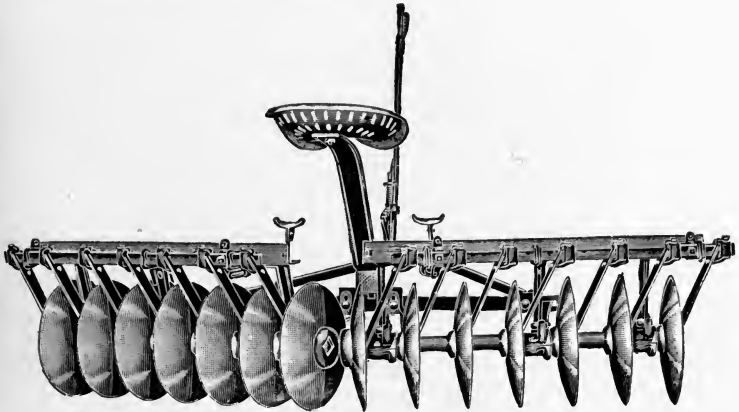

FIG. 89.—The full disk harrow.

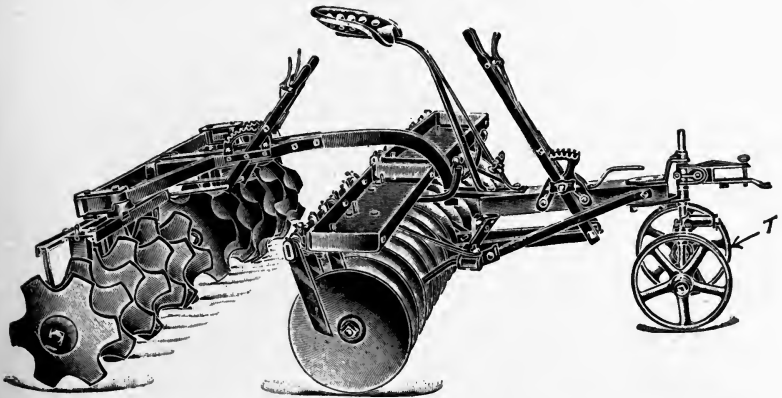

FIG. 90.—A double disk harrow. Cutaway disk in rear. *T*, truck or forecarriage.

**After Plowing, Harrowing.**—The implements commonly used after the plow are the disk and smoothing harrows (Figs. 89, 90, 91 and 92). No other tillage tool can pulverize the soil so thoroughly and quickly as the disk harrows. Of these, the full disk is in most general use. When the ground is very hard, stony, or when it is tough sod, the cutaway disk is especially good. The spading

disk harrow is frequently used on fields infested with quack grass, to bring the roots to the surface. It is always best to lap the disk

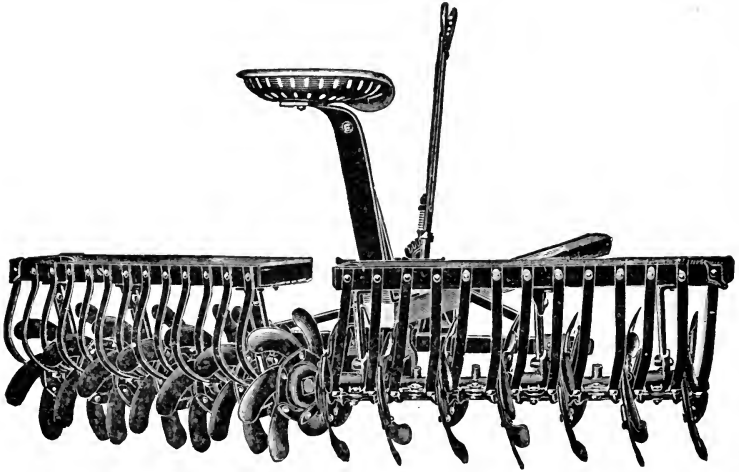

FIG. 91.—A spading disk.



FIG. 92.—The smoothing harrow. (Drag.)

harrow half to get best results in pulverizing fall plowed lands, sod or lumpy soil—except when two disk harrows are used in tandem. The degree of pulverization depends upon the angle at which the disks are set.

Commonly, the disk harrow is all that is required to prepare a good seed bed for small grains on potato and corn land. For weeding and summer fallowing<sup>3</sup> these machines are indispensable.

Sometimes it is desirable to use the disk harrow on land before it is plowed; to break up the surface crust or lumps, to cut up and work trash into the seed bed, and to conserve moisture. When disking is done for the first two reasons, the furrow slice comes into more intimate contact with the subsoil.

When the seed bed has been made sufficiently mellow or loose through disking, the smoothing or drag harrows are used to give the finishing touches.

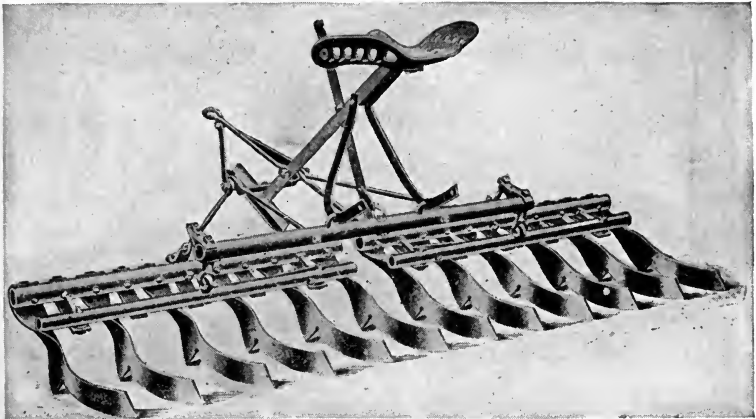

FIG. 93.—Acme harrow.

**Spring-Tooth and Acme Harrows** (Figs. 93 and 94).—The spring-tooth harrow is a most efficient tool on rough and stony ground, and on new land in wooded sections. It may also be used instead of the disk harrow, for pulverizing sandy and gravelly soils; and it may be used effectively in alfalfa fields to loosen the soil and eradicate weeds and grass. It is a more effective tool than the spike-tooth harrow.

The Acme or blade harrow is used to a considerable extent in some sections for pulverizing, compacting and for killing weeds. This machine gives best results on loamy soils free from stones.

<sup>3</sup> Summer fallowing is the tilling of uncropped land during the summer. This may be done with the plow or harrow. The common objects of summer fallowing are: to kill obnoxious weeds, to store rainfall of one year for the next, and to conserve moisture.

**Plankers.**—Sometimes, as in tobacco culture, and in market gardening, the planker is used when it is desirable to leave the surface particularly even and finely pulverized without firming it

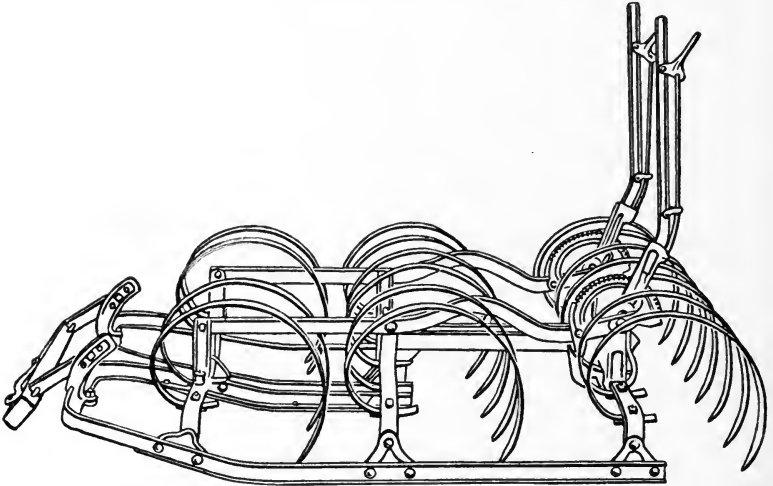

FIG. 94.—Spring tooth harrow.

(Fig. 95). This tool is usually made out of three to four eight-inch or ten-inch planks bolted together with their edges overlapping. The planker is not a compacting implement.

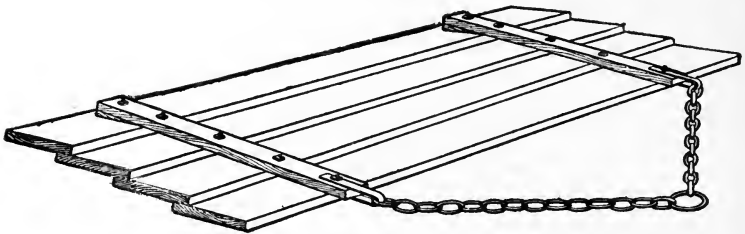

FIG. 95.—Planker.

**Rollers and Clod Crushers.**—Lumps are easily broken by means of rollers and clod crushers (Fig. 97). Very often, after harrowing, the seed bed is too loose or has not sufficient contact with the subsoil. If such be the case, rolling is necessary to compact the soil. Of all tools used for this purpose there is none better than the cor-

rugated roller, or, as it is often called, the cultipacker (Fig. 96). This machine crushes lumps, compacts the soil and at the same time leaves a thin mulch in the form of a corrugated surface.

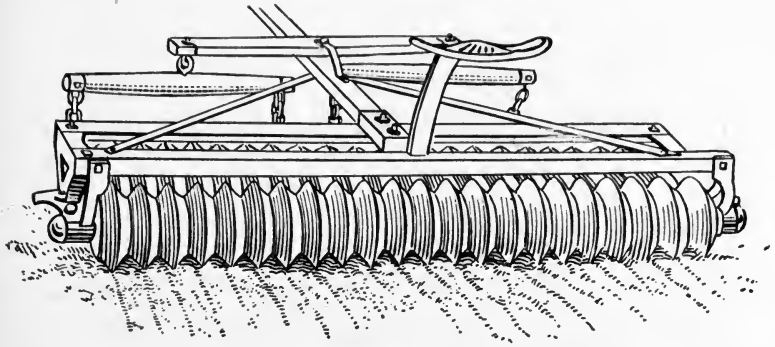

FIG. 96.—The corrugated roller or cultipacker.

Whenever a smooth or drum roller is used, it should be followed by a light spike-tooth harrow, with the spikes tilted, to form a mulch to conserve the soil moisture.

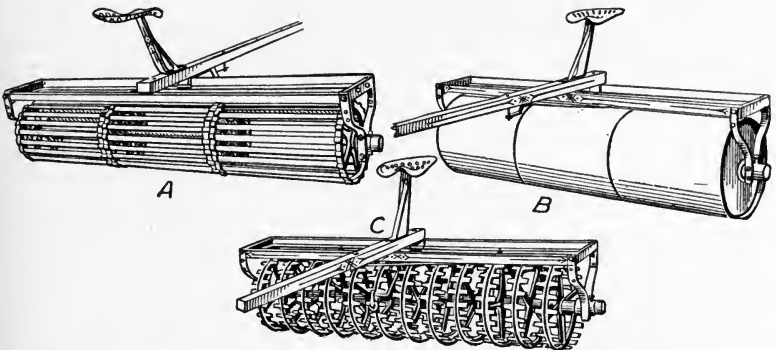

FIG. 97.—Three other types of rollers. A, pipe or tee bar roller; B, smooth or drum roller; C, crowfoot pulverizer (roller).

Muck, peat, sand, sandy loams and many loose silt loam soils are especially benefited by a cultipacker. When muck and peat soils are made firm they warm up quicker than when left loose.

The roller should never be used on the heavier soils when they are wet, but rather when they are in good working condition.

## SEEDING AND PLANTING

Soil conditions determine largely the different methods and types of machines used in seeding and planting; and the preparation of the seed bed is a most important factor in getting seeds well planted.

**Good Seed Bed Favors Planting.**—The advantages of a firm seed bed thus far discussed have been in relation to the germinating seed and the plant. Another advantage in having a firm seed bed is, the depth of planting can be easily controlled. Too often, grain, for example, is planted too deeply because little or no con-

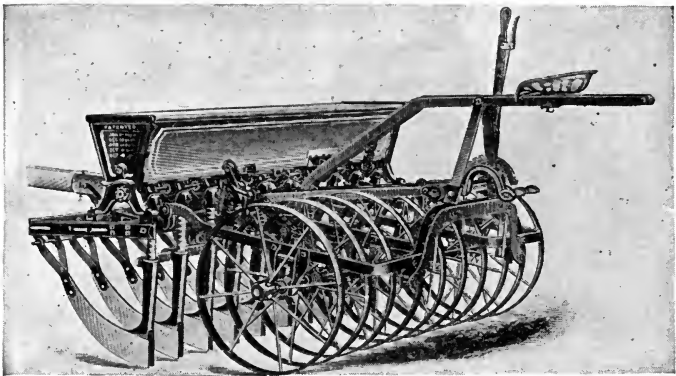

FIG. 98.—Press drill.

sideration is given to the looseness of the soil. If a drill is set to sow at a depth of one and one-half inches and the wheels sink down three inches in the loose soil, then the seeds are dropped at a depth of four and one-half inches. Grain seeds planted so deep may die for want of sufficient air, the stems may meet with too much resistance and never get through, or the food stored in the seed may become exhausted before the shoots reach the surface.

**Planting Seeds in Close Contact With Soil.**—The importance of having good contact between the seed and the soil, or having the soil pressed on the seed, is emphasized in the fact that corn planters, beet seeders, cotton planters and other planting machines are provided with press wheels. The use of water in transplanting is not only to supply easily available water, but also to cause the soils to come in close contact with the roots. Press grain drills and press-wheel attachments for the ordinary grain drills are also

in use (Fig. 98). Such grain drills are recommended for sandy soils and when trouble is experienced in planting, due to high winds blowing the soil and displacing the seed. In either case, the soil is pressed firmly on and around the seed; thus making germination more sure, and, in case of blowing, the seed with the soil pressed around it is held more firmly. Other drills are shown in Figures 99 to 101.

It is especially desirable to have excellent tilth when sowing grass seeds. Usually when alfalfa is to be sown broadcast on loose, loamy soils, best results are secured when the ground is rolled

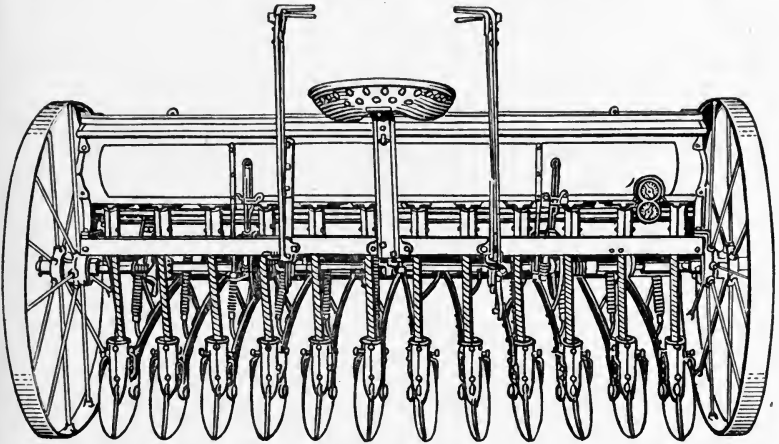

FIG. 99.—Single disk grain drill.

after harrowing or disking, then "dragged" with a light, spike-tooth harrow, the seed sown, the land dragged again to cover the seed, and finally the seed bed rolled with a corrugated roller. This provides a fine, firm seed bed, insures proper depth of planting, creates good contact between the seed and the soil, and provides a thin mulch to lessen evaporation. If an alfalfa drill is used, then only the roller is necessary after seeding.

**Drills vs. Broadcast Seeders.**—There are two classes of grain sowers—drills and broadcast sowers. Compare Figures 100 and 101. Of each of these there are several types. In some sections, farmers have definite knowledge as to which kind is best and most economical; while in other localities much difference of opinion prevails.

The drill has several advantages over the broadcast sower, viz., the seed can be planted at a uniform depth, less seed is required,

yields are better, and grass, clover and alfalfa have a better chance when grain is sown in drills. In general farming, the single disk drill is the most common, because it can do first-class work in any soil capable of being seeded. Many soils do not permit a satisfac-

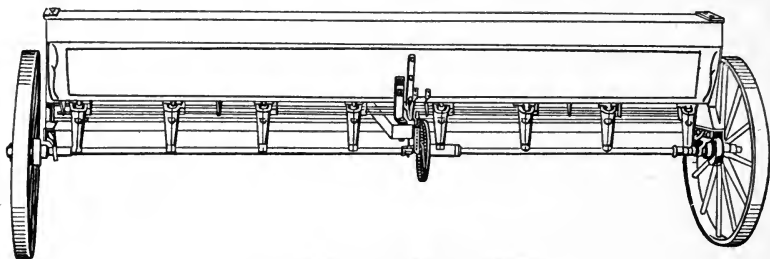

FIG. 100.—Broadcast grain sower.

tory use of the shoe drill, because the shoes do not scour. On stony ground and in breakings full of roots, the hoe drill gives especially good results.

Broadcast sowers are in general favor in the oat and corn sections (Fig. 100), and many are in use elsewhere. These imple-

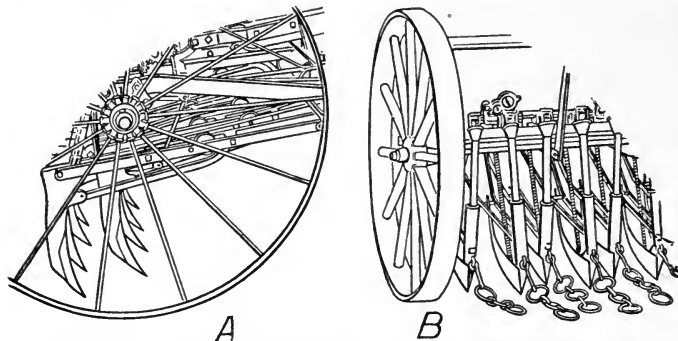

FIG. 101.—Two other types of grain drills. A, hoe drill; B, shoe drill.

ments scatter the seed on the ground, and some other machine must follow to do the covering. Some of these machines are broadcast sower and cultivator combined (Fig. 105). Here the seed is scattered over the loosened soil and is covered by the cultivator teeth.

Many farmers, especially those in the oat sections, simply broadcast the seed on unplowed and undisked corn land, then cover the seed by disking. This is possible only where soils are fertile



and where they seldom become hard and compact. This may seem a careless way of farming to those unfamiliar with the conditions encouraging this practice, yet it proves economical and gives good returns. Disking the corn or potato land to a shallow depth before broadcasting is the common practice with many farmers, and this is considered better than when no disking is done before seeding.

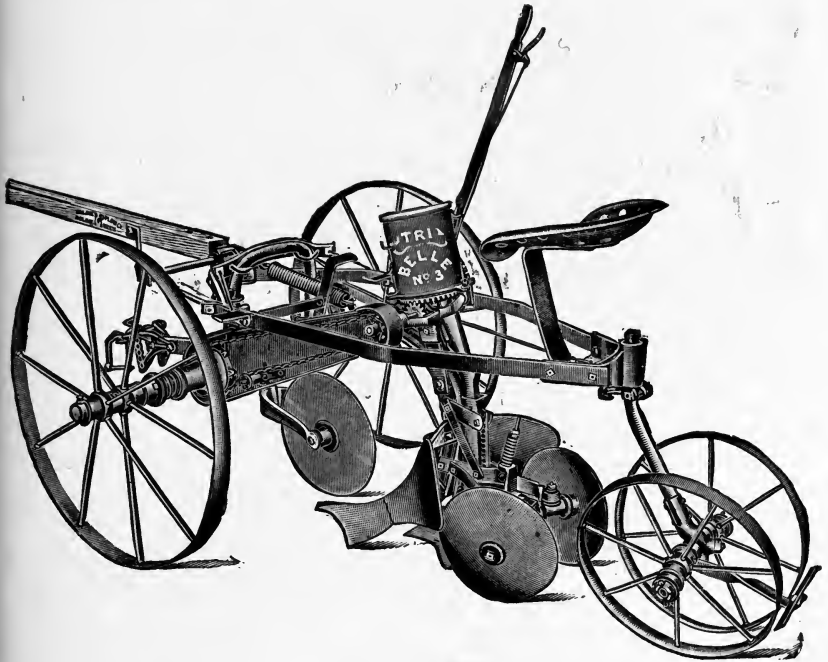

FIG. 102.—Lister.

**When Disking is Better Than Plowing.**—When oats are to be sown on potato or corn land in a high state of fertility, disking proves better than plowing. Many farmers have found that they can also grow better barley when the land is disked instead of plowed. This is especially true on black, crummy prairie soils, and crummy silt loams on many dairy farms. It is the experience of many dairy farmers that oats and even barley stand up better when such lands are not plowed.

**Listing** is primarily a method of planting corn in dry sections

particularly in the southern and southwestern states where light soils predominate, and where hot and dry weather often prevails during the growing season. The seed is planted in the bottom of



FIG. 103.—Work done by a lister. (Kansas Station.)

furrows made by a lister or middle-breaker, and later on, the furrows are filled by cultivation after the corn is up. This method

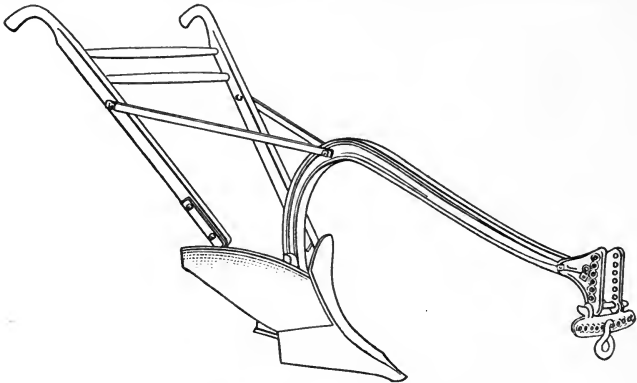

FIG. 104.—Middle-breaker, or middle-buster.

enables the roots to penetrate the soil deeply, and insures a better moisture supply (Figs. 102, 103 and 104).

One method of listing corn is to fall plow, give the land a fair amount of disking or cultivation in the spring, then plant by using a machine which is a lister and planter combined. Another

way is to list the land in the fall—and in the spring, the corn is planted in the furrows made by opening the previously made ridges or beds. The opening of the ridges is done by a lister or middle-buster. The middle breaking and planting are commonly done at the same time by the combination lister and planter. Frequently corn is planted with such a combination machine without any previous preparation of the land. Especially is this true when corn follows corn or cotton.

Cotton is commonly planted in furrows in a similar manner as listed corn.

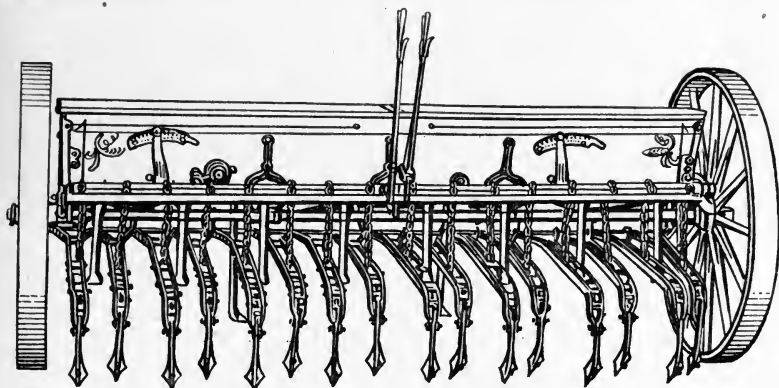

FIG. 105.—Broadcast seeder and cultivator.

#### CULTIVATION AND INTERTILLAGE

**Cultivation**, in its broad sense, means the act of tilling—but it is commonly understood to mean tillage done by cultivators. There are some tools designed to cultivate the land before planting, others that cultivate to cover the seed sown by them, and still others are designed for alfalfa fields (Fig. 105). The ordinary cultivators, however, are used for intertillage.

**Why Crops Are Cultivated.**—The objects of intertillage are commonly given as: (1) to kill weeds; (2) to conserve moisture, and (3) to aerate the soil.

In humid farming it is generally recognized that the killing of weeds is the primary importance of cultivation. This is especially true on soils in good tilth, and when frequent rains occur (Chapter VIII).

**Cultivation to conserve moisture** is good practice in all dry-land farming, and in sand management. On silt loams in humid

sections conservation of moisture and aëration are sometimes questioned, because different results have been attained under different conditions. A few of these results are of interest.

*In Illinois.*—On the common corn-belt soil of Illinois (brown silt loam) the following nine-year averages in corn were obtained:

Method of cultivation	Yield per acre
(a) Land plowed, seed bed prepared, weeds allowed to grow	7.4 bushels
(b) Land plowed, seed bed prepared, no cultivation, weeds kept down by scraping with hoe	48.9 bushels
(c) Land plowed, seed bed prepared, cultivated 3 times	43.3 bushels

*In Minnesota,* during a dry year, the following corn yields were secured on a "black loam soil containing considerable sand":

Method of cultivation	Yield per acre
(a) When all weeds were allowed to grow	0.4 bushels
(b) When weeds were cut with hoe without stirring soil	45.8 bushels
(c) When cultivated 6 times (3 times each way)	50.6 bushels

*In Wisconsin.*—On a heavy silt loam (Miami) the following results were secured during a year in which no beneficial rain fell during the period between July 3 and August 12:

Method of cultivation	Yield per acre (corn)	Rated quality of corn	Character of growth
(a) Land plowed, seed bed prepared, weeds kept down with a sharp hoe, soil not stirred in the least.	44.6 bushels	70 per cent	Uneven
(b) First two cultivations 3.5 inches deep; subsequent cultivation shallow, and as often as was necessary to kill weeds and maintain a good mulch.	74.8 bushels	99.5 per cent	Excellent and uniform

During a dry summer following a wet spring (1916), the following results were obtained in growing soybean hay in rows on sand at Hancock, Wisconsin. Very little rain fell between June 30 and August 15.

Method of cultivation	Yield of hay per acre
(a) No cultivation, but weeds were cut with a hoe; soil stirred the least possible.	1875 pounds
(b) Frequent cultivation	3660 pounds

Most farmers know the value of cultivation if for no other reason than to kill weeds; and when this is well done, the soil is usually kept well mulched and aerated. Crops on heavy soils, in particular, should receive careful attention in regards to cultivation. Too often cultivation is done as a matter of routine. Some plan to go through their corn, or other fields, three times or



FIG. 106.—A 6-shoveled sulky cultivator.

four times, with no thought as to the proper time in which it should be done, and with little thought as to why.

**Cultivators.**—Intertillage may be done through the use of several types of cultivators—each type designed to do its work in some particular way or to meet particular soil conditions. The shovel cultivators are the universal or most common implements. Of these, the six- or eight-shoveled sulky or riding cultivator has met with greatest favor, because of its general adaptability (Figs. 106 and 107). Many prefer the three-shoveled gang, while others the four-shoveled. Many different styles of these and other types of cultivators are made, each with various adjustments.

The spring-tooth gang cultivator (Fig. 108-A) is a very effective tool and it can be used under varied conditions, though in the heavier soils cultivators with rigid teeth do better work as a rule.

The surface cultivator gives good results in loamy soils and when they are comparatively dry (Fig. 108-C). In soils free from stones the blades may be sharpened to cut such weeds as thistles, quack grass, etc. When soils are comparatively moist, this machine does not stir the soil sufficiently to cover and kill small weeds, because the soil simply slides over the blades and the tiny weeds are but little disturbed.



FIG. 107.—A two-row riding cultivator.

The disk cultivator is quite commonly used in some localities. They do not seem to meet with general favor, though many were purchased when they first appeared on the market (Fig. 108-B). This type of cultivator is looked upon by some as a fad.

Lister cultivators are made especially for listed corn for first cultivation (Fig. 108-D). The ordinary two-horse, shoveled cultivator is used for the later cultivating.

Many styles of walking cultivators are in use (Figs. 109 and 110). In some sections these are generally used, while in others the common walking type is used when corn becomes too high for the sulky. Walking cultivators are especially favored by gardeners.

**When to Cultivate.**—The best time to kill weeds is when they are small or when the seeds are germinating. In order to do this

at the proper time the farmer must observe closely and often the condition of the different fields. Growing weeds may be killed

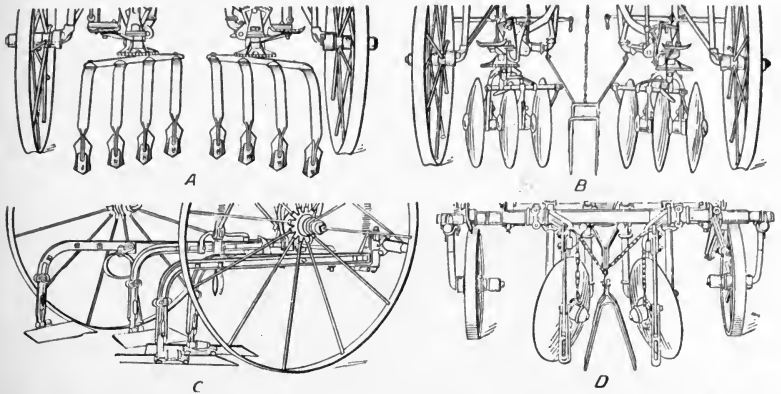

FIG. 108.—Other types of riding cultivators. *A*, four-shovel, spring-tooth gang; *B*, disk cultivator; *C*, surface cultivator; *D*, single row lister cultivator.

through cultivation in three ways: (a) They may be loosened and exposed to the drying sun; (b) they may be covered and

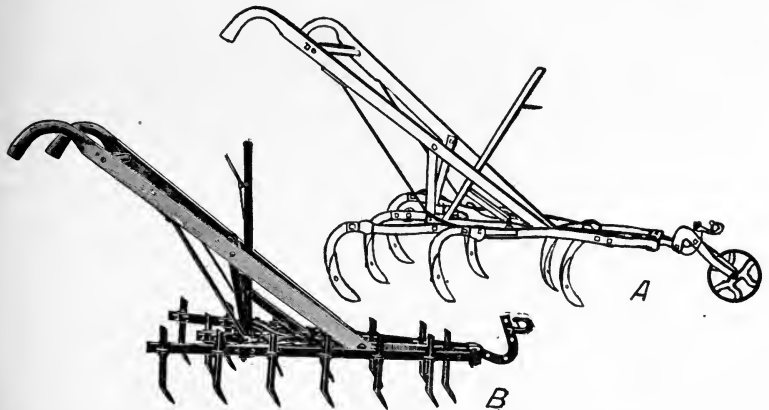

FIG. 109.—Two types of walking cultivators. *A*, seven-shovel one-horse cultivator; *B*, fourteen-tooth cultivator.

smothered with soil, and (c) they may be cut off or covered with soil to prevent their manufacturing any food. In the last one, much diligence and close watching is required. Some prefer to

kill obnoxious weeds in the third manner by summer following, quack grass and Canada thistles especially.

Cultivation to conserve moisture should be done before the land is allowed to dry out. A good mulch should be prepared at the beginning of a dry period.

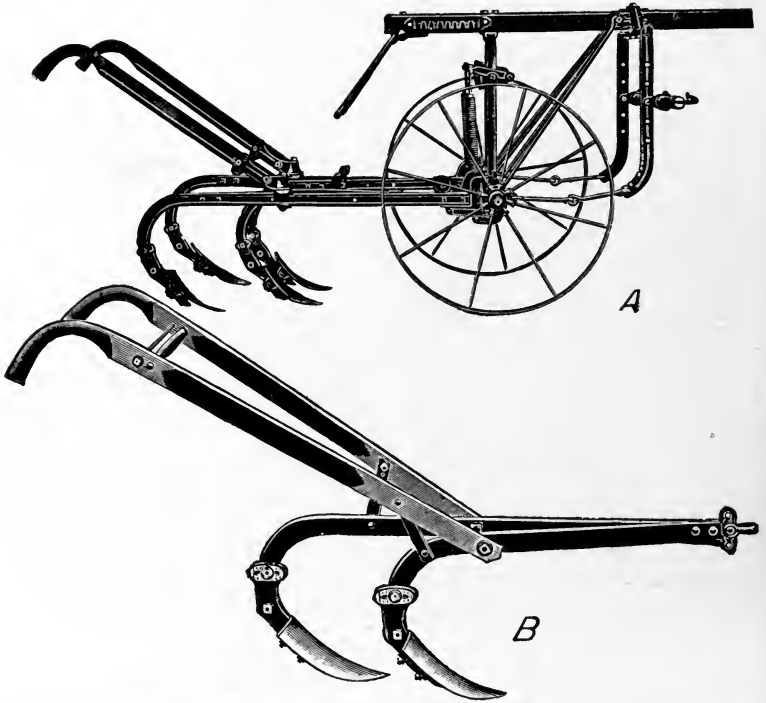

FIG. 110.—Two other types of walking cultivators. A, four-shovel; B, two-shovel cultivator, or double shovel plow. B is a cultivator commonly used in the South.

Crops on heavy soils are best cultivated, especially for the first time, when the moisture conditions are right. When this is done subsequent cultivations are made much easier because a layer of well-loosened soil prevents baking.

Some soils, particularly the black lowland silt and clay loams, shrink considerably when they dry out, causing big cracks to form. Such lands should be cultivated frequently to prevent as much as possible the formation of these cracks, and to fill them when they do occur (Fig. 111).



**Shallow Cultivation Gives Best Results.**—In humid farming results in general are in favor of shallow cultivation. The only time when it is safe to cultivate deep at all is when the plants are very young, and before they send their feeding roots into the surface soil. Much harm results in deep cultivation (four to five inches), in cutting these feeding roots. The only way to determine whether or not cultivation is too deep is to investigate what the cultivator teeth are actually doing. If the shovels next to the row



FIG. 111.—Cracks like these are moisture chimneys.

are going too deep and cutting the roots, they may be raised; and if all the teeth are doing injury they should be set for more shallow work.

**Level Cultivation Generally Best.**—Hilling corn does not increase the yield, hence level cultivation is more desirable. In some localities hilling the corn is a common practice because it has always been the custom. A farmer gets the hilling habit when he allows the weeds to get ahead of him. It then becomes necessary to throw much dirt on the rows in order to cover the weeds. If this must be done, and in some instances it is necessary to cover such weeds as the wild morning-glory later cultivation should be done, if possible, at right angles to the ridges to level them. In

this respect planting corn in check rows is advantageous. Because of the action of the shovels, proper cultivation leaves a slight slope between the rows.

The high hilling of potatoes has no particular advantage. When this is done more surface is exposed and hence more moisture is lost through evaporation. When potatoes are grown on the heavier, compact soils, digging is made easier when they are ridged a little; and, moreover, the throwing of some loose dirt



FIG. 112.—Walking weeder and its work.

on the hills becomes necessary as the potatoes advance in growth to protect the tubers from sunburning, since in many silt loams the growth of the tubers causes cracks to form around the hill, which let in the light.

**Weeders.**—(Fig. 112). The weeder is a weed-killing and mulching tool consisting of many narrow spring teeth. It is adapted for killing very small weeds in corn, potatoes, etc., either before or after the plants are up. This is not an effective tool when weeds are quite large or when the ground is at all hard or heavy.

A light, spike-tooth, smoothing harrow is often used in place of a weeder.

**Emergency Tillage Operations.**—Sometimes it is not convenient to compact the seed bed or break lumps before planting. In this case, if the soil is still too loose or lumpy, grain and even corn land may be rolled after the crop is up. This should be done when the plants are small.

When grain is grown on heavy soils, it is best to leave the seed bed covered with a layer of small, loose lumps. This is not so favorable for the formation of crusts as in case of finely pulverized soil.

Heavy rains often pack the soil so firmly after the crop is planted that hard crusts form, which prevent the penetration of shoots and stems. A spike-tooth harrow is often used to break the crust, and sometimes a roller gives best results. Beans often break their necks in trying to get through a hard, crusty soil. In such a case the hoe or the careful use of a cultivator is best to break the crusts.

**Home Experiments and Projects.**—**To Demonstrate That it Pays to Cultivate corn.**

*Procedure.*—Secure a small plot of ground, preferably heavy, silt loam (about  $\frac{1}{4}$  acre), and divide equally into three parts. Treatment up to cultivation time should be the same on all plots. Plant each plot to the same kind of corn. Give the corn on plot No. 1 thorough cultivation, and maintain a good mulch especially during dry periods. Plot No. 2 is to receive no cultivation at all, but all weeds should be kept down with a sharp hoe. The soil should not be stirred in the least. All weeds should be allowed to grow in plot No. 3. At harvest time cut out the row between adjoining plots. Discard. Determine yield of corn on acre basis. Keep cost accounts to ascertain comparative profits. (During seasons of frequent and sufficient rains, but little difference may result in yields on the first two plots. It would be best to continue this project for at least 3 or 4 years.)

**To Determine the Advantage, if any, in Hilling Corn.**—*Procedure.*—Select 14 rows of corn in a corn field. Practice level cultivation on seven of the rows and hill the other seven rows. Discard the middle row, and determine comparative yields. What are some of the disadvantages of hilling?

**Field Studies.**—Examine different plows, harrows, cultivators, rollers, and planting machines. Study their action in relation to the soil.

It would be well, if possible, to compare the work of a stubble plow in plowing sod with that of a sod plow.

### QUESTIONS.

1. What is the relation of good tilth to soil fertility? Give the meaning of good tilth.
2. What constitutes a good seed bed? What is intertillage?
3. Name and discuss the factors influencing the development of a good seed bed.
4. Name the common tillage tools. What should guide the farmer in his purchase of tillage and planting implements?
5. What are some of the common objects of tillage?
6. State some (eight) of the principles governing tillage.
7. What is the use of the plow?

8. Name the parts of a common walking plow. What is a jointer? Coulter? Illustrate by sketch the proper adjustments of jointers and coulters. (Fig. 74.)
9. Describe the pulverizing action of the moldboard; illustrate by diagram or otherwise.
10. How does stubble plowing differ from sod plowing?
11. What constitutes good plowing? (Figs. 68, 71, 76, 78, and 87).
12. What is a disk plow and when is it used? Why are they not recommended for light, loose soils?
13. Name some of the advantages of late fall plowing. Disadvantages. Why leave fall plowed land rough?
14. What is a puddled soil?
15. Discuss spring plowing—advantages and disadvantages.
16. Why and when is deep plowing generally best? When is shallow plowing best?
17. Why is it not good practice always to plow at the same depth? What is a better way?
18. What is subsoiling? Is it generally recommended? Why? What about deep tilling?
19. How may dynamite be used in connection with tillage?
20. What is a hillside plow and how used? What are gang plows—their advantages?
21. What are harrows? Name and describe the use of the different types.
22. What is meant by summer fallowing?
23. What is a planker and for what is it used?
24. Name and describe the common rollers or clod crushers. When should they be used? When not? What is a precaution to observe in the use of a smooth or drum roller?
25. Why are light, loose soils especially benefited by cultipackers?
26. What are the advantages of good tilth or a firm seed bed in relation to planted seeds and growing plants? Discuss another advantage in having a firm seed bed.
27. What has been the effect of the principle of good contact between the seed and the soil on the construction of many planting and seeding machines?
28. What is a good program to follow when alfalfa is to be sown broadcast on loose, loamy land?
29. Which is better to use for sowing grain—drills or broadcast sowers? Do all drills give the same satisfaction? Explain.
30. Under what conditions is disking better than plowing for grain, particularly oats? Why?
31. What is listing? Where and how is it done? What is a "middle-buster"?
32. Give the meaning of cultivation. What are cultivators?
33. Name and discuss the objects of intertillage.
34. Name and discuss the use of the different implements used in intertillage.
35. What should guide the farmer as to what particular tool to use, and how and when to cultivate?
36. What is the depth of cultivation best for humid farming? Why?
37. How is a farmer to know when he is cultivating too deep?
38. What machine adjustments may be made to eliminate injury in cultivation?
39. Discuss level cultivation and hilling.
40. What are weeders, and when do they prove effective tools?
41. Does it injure grain or corn if it is necessary to roll land when the plants are small?
42. How may crusts be broken after crops are planted?
43. Have you ever known of cases of harrowing small grain while young? What were the results?
44. For an outline summary of this chapter, see table of contents.

## CHAPTER XI

### SOIL ORGANISMS IN RELATION TO SOIL FERTILITY

In Chapter II it was stated that millions of organisms live in the soil, and that many of them bring about changes that are fundamentally important in determining fertility. These many organisms may be classed as bacteria, fungi, yeasts (Fig. 113), algæ (äl'je), worms, insects, and rodents. The first three groups are classed as "microorganisms" because they are of microscopic dimensions. The majority of the bacteria are not more than

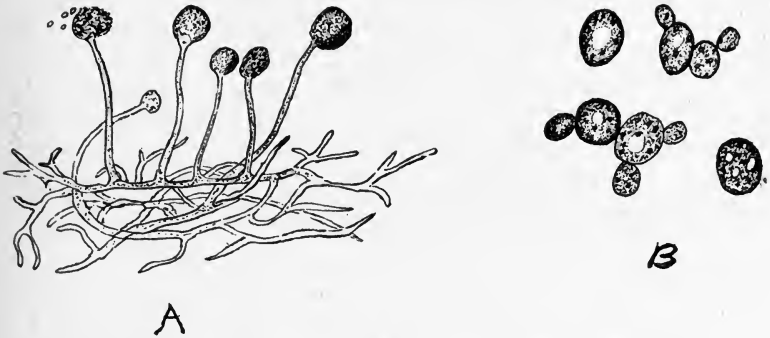

Fig. 113.—Other soil organisms. A, a common mold; B, yeast plants.

0.0000197 of an inch in diameter, and it is believed that some are too small to be seen with the aid of the most powerful microscope. In one-third of a thimbleful (one gram) of normal field soil have been counted from 140,000,000 to 400,000,000 microorganisms; and in manured soil, as high as 750,000,000. The most tiny ones (bacteria) are in greatest abundance, and it is they which play a large part in nature's plans, and stand in close relationship to the practices which make possible successful crop production.

In this chapter will be considered in particular three groups of the helpful soil organisms, viz.: (a) Those which cause decomposition or decay; (b) those which cause nitrification, and (c) those which gather nitrogen from the air.

#### ORGANISMS OF DECOMPOSITION

**Microorganisms Clear the World of Trash (Fig. 114-A).—**What would this world be were it not for the fact that all plants

and animals finally disappear after they die? If this were not so the world long ago would have become choked with dead material. Most of the rubbish of the earth is buried in or is thrown upon the soil, and through decay, it is reduced to the fundamental elements, becoming again the dust of the earth, water and gases. This decay is the work of many kinds of microorganisms, particularly the bacteria and fungi. It is a wise provision of nature that all organic matter can again break down into the elements of which it is composed, since through these changes sustenance is provided to prolong the life on the earth and to make possible new life.

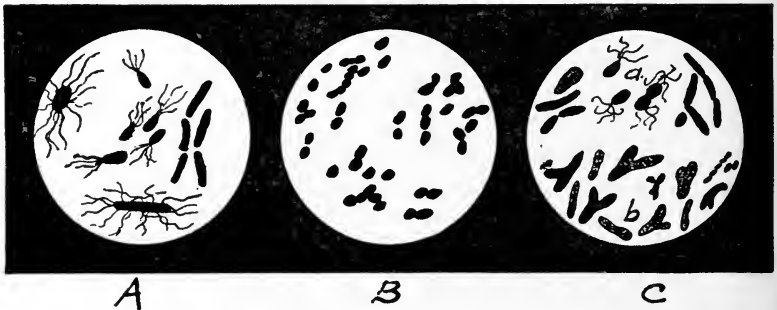

FIG. 114.—The important soil bacteria. A, common bacteria causing decomposition; B, nitrifying bacteria; C, nitrogen-fixing bacteria; a, free nitrogen-fixing; b, nodule bacteria.

**No Crops Without Decay.**—Soils continue to weather<sup>1</sup> after they are formed from rocks; and because of weathering, crops are able to secure from the mineral rock particles the mineral elements so necessary for their growth. But crops also require nitrogen—and the nitrogen in the soil is held there, not in the mineral particles, but mainly in complex, insoluble compounds in the form of organic matter. Crops cannot absorb this organic matter any more than they can consume the mineral particles of the soil. Before plants can secure any nitrogen from this organic matter, and before any crops can be grown successfully at all, the organic matter must first undergo decomposition. Herein myriads of microorganisms do a most important work.

**Crops Secure Mineral Elements From Two Sources.**—At the

<sup>1</sup> Weathering is a broad term meaning the breaking up and decay of material things wrought by natural forces. Decay of soil is largely the result of chemical forces acting independently or through the aid of microorganisms.

same time that the nitrogen compounds in the soil organic matter pass through the changes necessary to provide available nitrogen, the mineral elements, which this organic matter contains, likewise become available. Thus a crop such as corn, for example, secures its supply of nitrogen from one main source—the soil organic matter; and its supply of mineral elements from two sources—from the mineral soil particles and from organic matter.

**Decay of Organic Matter Aids Decay of Mineral Particles.**—The organisms which cause the decomposition of the soil organic matter perform a two-fold work. They not only bring about the necessary changes in the organic matter to provide available nitrogen and mineral elements for use by plants, but in an indirect way they aid in the liberation of mineral elements contained in the mineral soil particles. This is explained through the fact that in all organic decay, acids are formed which are effective agents in dissolving mineral matter. We can now understand more clearly why it is important to maintain a good supply of organic matter in soils to enable crops to secure needed and sufficient elements. It is significant that rich, garden soils usually have a high content of organic matter, and that they are much more abounding in life than ordinary field soils. We can explain, too, why some light-colored soils rich in all the important mineral elements and having a low productive power, can be made to produce much larger yields simply by plowing under a good growth of green rye.

**Some Fertilizers Valueless Without Decay.**—Were it not for the organisms of decomposition, fertilizers such as tankage, blood meal, cottonseed meal, etc., would be of little or no value. Moreover, some insoluble mineral fertilizers, such as rock phosphate, would be practically useless, but for the presence of decomposable organic matter in the soil, or because of the organic matter in which the fertilizer may be mixed when applied. Rock phosphate has been found to give best results in most soils when it is mixed with manure or plowed under with green rye or clover.

#### NITRIFICATION

**Nitrification Explained.**—The accompanying diagram (Fig. 115) is helpful in gaining a clear idea of the meaning of nitrification.

This diagram explains that the nitrogen in organic matter is held there in the form of complex, insoluble compounds which must be broken down, through decomposition, into simpler com-

pounds, and much of it finally into ammonia (gas) before the nitrogen can be converted into available form suitable for plants. This breaking-down process is brought about by fungi as well as by bacteria. As soon as the ammonia is formed, other bacteria, called nitrifying bacteria or nitrifiers, convert it into soluble nitrogen-containing salts, called nitrates.<sup>2</sup> This conversion of ammonia into nitrates by nitrifying bacteria (Fig. 114-B) is termed "nitrification." The opposite of nitrification is denitrification, which means the breaking down of nitrates by certain organisms which work only when the air is shut out of the soil. Under good soil management we need not concern ourselves about this destruction of nitrates.<sup>3</sup>

**What Becomes of the Nitrates Formed.**—Nitrification is usually most rapid during the growing period. The nitrates then formed are almost completely and immediately absorbed by the growing crops, unless too much is manufactured. If no crops are present to utilize the nitrates, or when too much is formed, they are leached out of the soil and lost. Ordinarily more nitrates are produced in a rich, cultivated soil than are used by the crop.

An idea as to the rate at which nitrification goes on in some soils may best be gained by studying the nitrogen needs of good crops of corn, sugar beets, and cabbage. During cold weather nitrification ceases.

**The Use of Catch and Cover Crops.**—Since certain crops are harvested early, some soils are left bare during the fall months. It has been found that much nitrates are formed during this time and lost from the soil. To conserve this nitrogen, rye or some other crop is sown immediately after the harvesting of these early crops. Such crops are commonly called "catch" or "cover" crops. They not only prevent nitrogen losses, but they prevent soil washing and blowing, and improve the soil when plowed under. In the South, rye, either alone or with hairy vetch or crimson clover, is frequently sown as a winter cover crop. In cultivated orchards, the most common cover and catch crops are rye and clover.

---

<sup>2</sup> Ammonia is a gas composed of one atom of nitrogen and three atoms of hydrogen, hence the chemical formula,  $NH_3$ . The strong smell of washing ammonia-water is due to this gas.

The last stage of decomposition in which ammonia is formed is called "ammonification."

<sup>3</sup> It is to be noted that the decomposition is a breaking-down process, and nitrification is a building-up process. A common nitrate formed in soils is calcium nitrate  $[Ca(NO_3)_2]$ , which is a more complex substance than ammonia.



**Nitrification Means Loss of Organic Matter.**—The bacteria engaged in nitrification do not add one atom of nitrogen to the soil supply; they simply change insoluble forms of nitrogen into soluble forms which are either used by plants or are leached from the soil. This explains in a large measure how the soil organic matter is used up; and it also emphasizes the necessity of maintaining a good supply of this material in soils as a source of easily available mineral elements as well as of nitrogen.

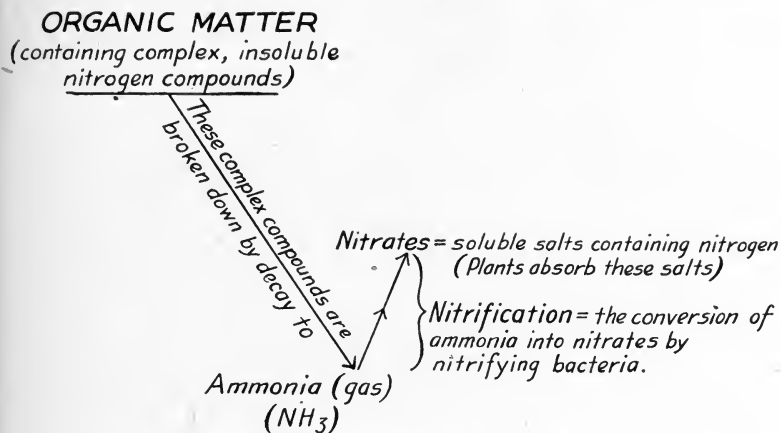

FIG. 115.—Diagram illustrating nitrification.

**Some Soils Lack Nitrifying Organisms.**—Some peat and muck soils, on being reclaimed through drainage, fail to produce satisfactorily even though mineral fertilizers be supplied. Such results are sometimes due to a lack of “available” nitrogen, in spite of the fact that these soils may be well supplied with, or are composed almost entirely of, organic matter. Decomposing and nitrifying organisms may be lacking. Since good manure, especially horse manure, contains myriads of these kinds of organisms, they may be supplied to such soils through manuring. This explains in part the beneficial effect of manure, as a first treatment, to many peat and muck soils.

NITROGEN FIXATION BY SOIL BACTERIA

**Nitrogen Fixation by Nodule Bacteria.**—For many years scientists were puzzled to know three things: (a) Why a clover plant could grow perfectly well when no available nitrogen was

supplied to it; (b) why legumes, that is, such crops as clover, peas, beans, etc., should enrich the soil considerably in nitrogen, and (c) why a crop like wheat or turnips, for example, should pro-

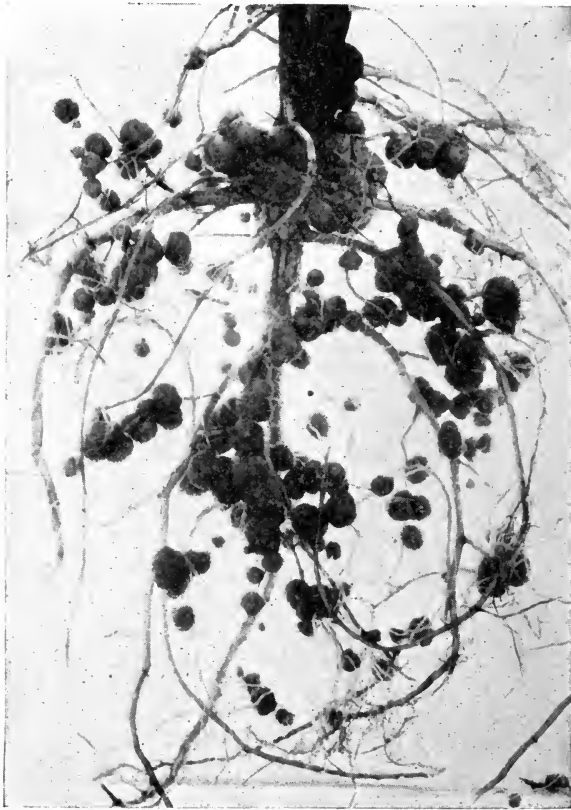

FIG. 116.—Nodules on the roots of soybean. (Wisconsin Station.)

duce much larger yields on clover sod than when grown on such a sod as timothy.

It was known centuries ago that certain plants had bunches or nodules on their roots; and it was known for forty years that these nodules contained bacteria. Yet it was not until 1886 that two German investigators proved conclusively that these bacteria within the nodules actually have the power of taking the free



FIG. 117.—Crimson clover nodules. (U. S. D. A.)

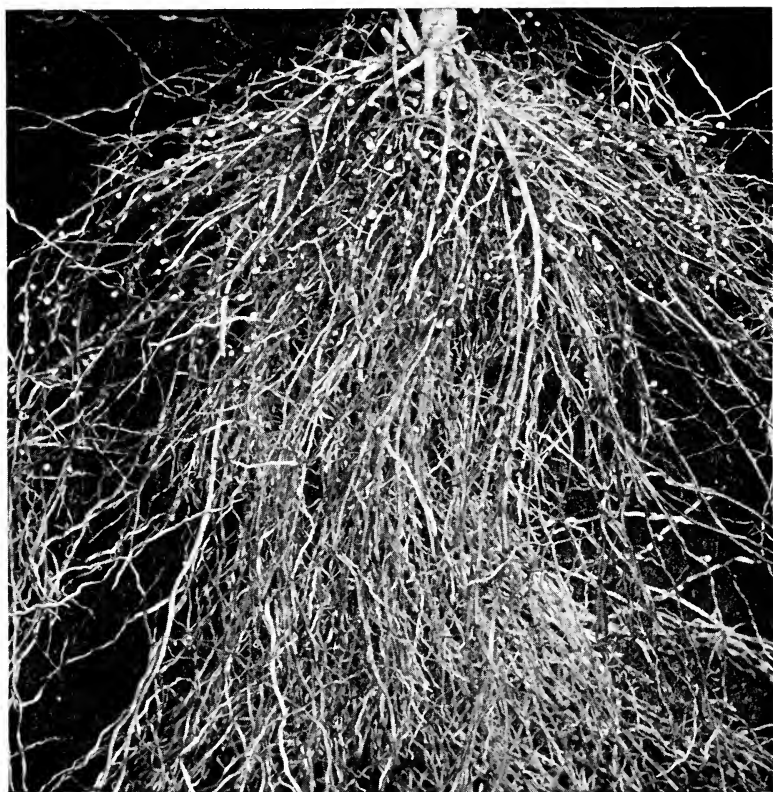

FIG. 118.—Nodules on roots of medium red clover. (Wisconsin Station.)

nitrogen from the soil air and converting it into a form suitable for the plant (Figs. 114-C, 116, 117, 118 and 119).

There are three main differences between legumes and other plants: (a) They are very rich in nitrogen; (b) they usually have nodules on their roots, and (c) they may increase the nitrogen supply of the soil through the action of the nodule bacteria.

Nodule organisms are also called "symbiotic bacteria." They have the power of independent existence, but when they enter the roots of legumes both the bacteria and plants are benefited by the close association.

**Nitrogen Fixation by Free Soil Bacteria.**—Aside from the bacteria which cause the formation of nodules, there are bacteria

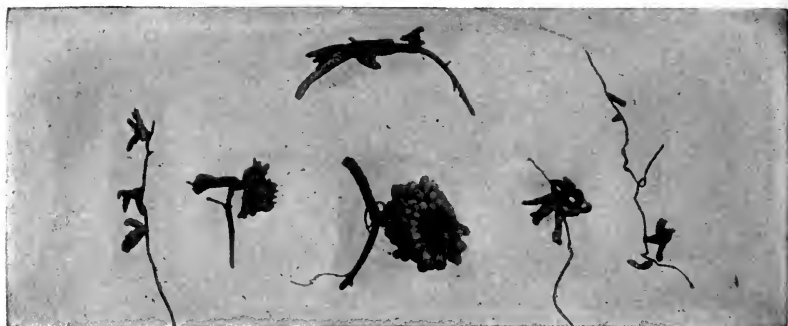

FIG. 119.—Different forms of alfalfa nodules. (U. S. D. A.)

in the soil which have the power of fixing or gathering nitrogen independently of any roots or plants. These are commonly called the free nitrogen-fixing organisms, or non-symbiotic bacteria.

From what has been said it can be concluded that nitrogen fixation in soils is the fixing or gathering of atmospheric nitrogen by nodule bacteria and by free nitrogen-fixing organisms.

Nitrogen fixation may also be accomplished artificially through the use of electricity.

Certain molds and algæ in soils also seem to have the power of fixing free atmospheric nitrogen.

Nitrogen-fixing bacteria are classed as plants, as are the other important soil bacteria.

**Amount of Nitrogen Gathered.**—Under field conditions it has been estimated that the free nitrogen-fixing bacteria gather and add to the soil annually from fifteen to forty pounds of nitrogen

per acre. The amount gathered by the bacteria may vary from forty to two hundred pounds to the acre per year, depending upon the amount of crop growth and soil conditions. This does not mean that the nodule bacteria actually add to the soil this amount of nitrogen, but rather it is the amount the bacteria furnish to the legume.

**How Nodule Bacteria Work.**—Nearly everyone is interested in knowing how the minute nodule bacteria aid legumes in getting

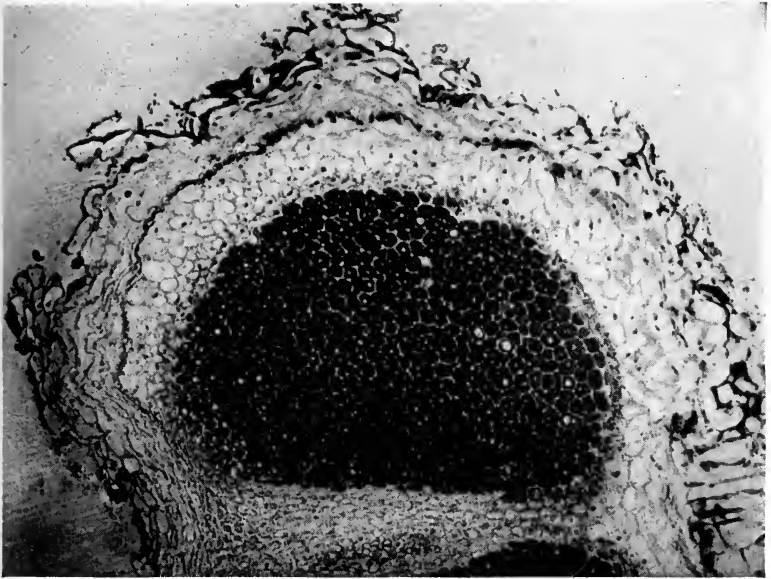

FIG. 120.—The inside of a lupine nodule, magnified. (U. S. D. A.) (See Fig. 121.)

their nitrogen. These organisms naturally live in the soil, and when they come in contact with the legume root they enter it and grow rapidly, causing an abnormal growth known as tubercles or nodules. As the plant grows, the bacteria multiply and the nodules increase in size and in number (Figs. 120 and 121). Each nodule contains millions of these bacteria. They feed upon the plant juice and, in return, furnish the plant with nitrogen which they take from the air in the soil and combine it in a form suitable for the plant. About the time seeds form on the legume the nodules cease growing, lose their plump appearance, begin to shrink, and finally die,

the bacteria returning to the soil in vast numbers. Here they may remain for a considerable length of time before they have an opportunity to enter other plants and again gather nitrogen and multiply.

**How the Growing of Legumes Improves Soils.**—The growing of legumes may improve soils directly in two ways: by adding organic matter and by increasing the nitrogen content. The amount of nitrogen that may be actually added to the soil in growing a crop of clover, for example, depends upon the soil and especially upon what disposition is made of the crop. The crop

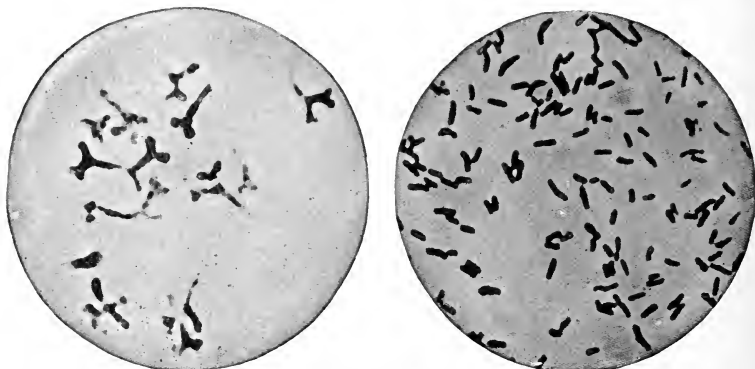

FIG. 121.—A few of the bacteria which fill the cells, highly magnified. (U. S. D. A.)

may be plowed under, it may be cut for hay and sold off the farm, or it may be fed on the farm, either as pasture or hay.

In studying the clover plant, it has been found that practically two-thirds of the total nitrogen contained in it (roots and all) is in the hay, and one-third in the roots. Under average, normal soil conditions, the clover gets about two-thirds of its nitrogen from the nodule bacteria, and one-third from the soil reserve. Thus when the crop is taken off the field, there is left in the roots practically the same amount of nitrogen as was taken from the soil supply. The nitrogen content of the crop harvested, therefore, represents the amount fixed or taken from the air by the nodule bacteria.

It follows that when a clover crop is plowed under, the soil is enriched by the amount of nitrogen contained in the clover plowed under. This amounts to about forty pounds for every ton of hay

equivalent; that is to say, if a crop of clover that would yield two tons of hay were plowed under, the soil would be enriched by about eighty pounds of nitrogen per acre.

When the clover is cut for hay and sold off the farm, the field growing the crop is not enriched. If at the start the soil were very rich the nitrogen content would even be less after the growing of the clover. On the other hand, if the soil were comparatively poor in available nitrogen, a gain would result.

When the clover crop is fed on the farm, the amount of nitrogen that may be gained is equal to the amount contained in the hay minus the loss in feeding. When manure is well cared for, there is a possibility of regaining about sixty per cent of the nitrogen in the hay, or about twenty-four pounds for every ton of clover hay fed.

What was said of clover may apply to alfalfa except that one ton of alfalfa hay contains fifty pounds of nitrogen. Information concerning other kinds of legumes is meager; nevertheless, it remains true that a legume can add about twice as much nitrogen to the soil when it is plowed under as when it is fed and the manure returned to the land.

Certain investigations have shown that the roots of cowpeas, soybeans, crimson clover, etc., contain a very low per cent of the total nitrogen. Very probably when these crops are removed from the land, some nitrogen is removed from the soil.

**Clover Sod Better Than Timothy.**—Under like conditions it is well known that a corn crop, for example, on clover sod yields much better than on a timothy sod. This is largely because clover roots are very rich in nitrogen, and they decompose rapidly, thus causing the liberation of a good supply of plant-food elements.

**Crop Failures Owing to Lack of Nodule Bacteria.**—Poor yields, and even absolute crop failures, are not rare experiences resulting from a lack of proper nodule bacteria. Lack of alfalfa nodule organisms was the cause of twenty-six per cent of the alfalfa failures studied in the south half of Wisconsin in the period between 1912 and 1917. It is a common mistake to think that because one kind of legume grows well on a certain soil any other kind of legume would necessarily thrive there. This is not the case, however, since different species of legumes require quite different species of nitrogen-fixing bacteria. Many farmers have experienced absolute failure in alfalfa because they thought that

since they could grow excellent clover and corn, alfalfa should likewise do well.

It is necessary that legumes have these bacteria to help them secure the large amount of nitrogen they demand. In exceptionally rich soils the nodule bacteria are not so necessary, because there the plants are able to secure their nitrogen requirement directly from the soil. It is usually true that wherever a certain legume has never been grown, there a lack of the proper bacteria prevails—except in cases where the same bacteria can grow on one legume as well as on another.

Alfalfa bacteria grow without difficulty on sweet clover, bur clover and black medick; or vice versa.

The bacteria causing the formation of nodules on medium red, alsike, crimson, mammoth and white clovers may be grown interchangeably.

The nodule bacteria on the following legumes can grow on one as well as on another: Garden, field, and sweet peas, and vetch.

**Soil Inoculation.**—It is a comparatively simple matter to add to a soil the necessary legume bacteria. This process is called “soil inoculation.” Usually, whenever a particular legume is to be grown on a field for the first time, and especially when for the first time in that locality, it is a safe rule to inoculate the soil. If the legume is soybean, inoculate with soybean bacteria; if alfalfa, inoculate with alfalfa bacteria; if it is field pea, inoculate with field pea bacteria, etc. The successful growing of the common garden pea may depend largely on proper inoculation. (Fig. 122.)

**Methods of Soil Inoculation.**—Several common methods are used in inoculating soils. Soil may be taken from one field growing the legume successfully and applied to another field upon which is to be grown the same legume. The soil is taken from the surface six or eight inches. A bushel of well pulverized soil is sufficient to inoculate one acre, though farmers usually use about a wagon-box full for three to four acres. Usually the soil is spread by hand. Since sunlight is a destroyer of germ life, it is necessary, if the soil is quite dry and the sun is shining bright and warm, to harrow the land immediately after the inoculating soil is applied.

The seed-agglutination method of inoculating for legumes is now commonly used. Procure a peck of soil which has plenty of the right kind of bacteria. Put half of this into a tub of clean water. Stir thoroughly and while stirring add a pint of liquid glue.



Now wet the seeds by sprinkling this muddy water over them and stirring them with a hoe or rake until all are wet. This wetting



FIG. 122.—Effect of inoculation on garden peas. Inoculation alone will often increase the yield of peas. 1, no inoculation; 2, inoculation. (Wisconsin Station.)

can easily be done with the seeds in a shallow box or on a smooth floor. Next sift the remainder of the good soil over the seeds and

stir until the moisture is taken up by the soil. The seeds are now ready to be drilled in the field.

Another common way to inoculate is to apply the bacteria to the seed as pure culture at the time of seeding or planting. Pure inoculation cultures are bacteria grown in the absence of all other kinds of bacteria on sterilized foods. These pure cultures may be sent out to farmers in liquid form, on vegetable jelly, or in sterilized soil. Good results are secured through this method of inoculation only when fresh cultures containing the proper organisms are used. Farmers may secure pure inoculation cultures from the United States Department of Agriculture, from their State Experiment Station, or from reliable seed houses. Full directions for using accompany the cultures.

Some recommend the sowing of about a pint of alfalfa seed per acre in with the usual seeding mixture of clover and grass as a means of inoculating the soil for alfalfa. In actual practice this is not a safe and sure method of inoculation. It is rather a test to determine whether or not the soil conditions are right for alfalfa. Moreover, an acid soil is usually lacking in the alfalfa nodule-bacteria, so that any attempt to grow a few alfalfa plants on such a soil results in failure, not only because of the lack of the proper organisms, but also because of the lack of lime. To be sure of inoculation on non-acid soils it is best to inoculate with soil or pure culture. On acid soils, the only sure way to succeed, especially with alfalfa, is to lime the land first, then inoculate.

**How Often to Inoculate.**—Usually when a soil becomes inoculated and grows a certain legume successfully, further inoculation for that particular legume is unnecessary, provided the soil conditions remain favorable for the bacteria.

**Conditions Favoring Soil Organisms.**—As in case of all living things, the growth and activity of all the helpful soil organisms are promoted only when favorable conditions surround them. Aside from food and suitable moisture and temperature conditions, they particularly require a well-aërated soil, a soil containing a sufficient amount of organic matter, and most of them require a soil not sour or acid. These last three conditions are within the control of the farmer, thus making it possible for him to plan and direct his farming operations in such a way as to foster these tiny workers in the soil.

**Illustration Material for Lessons.**—Show nodules on the roots of some of the common legumes.

**Demonstrations.**—*Material Needed.*—Five one-gallon crocks; about 12 quarts of loam; about 10 quarts of soil void of alfalfa nodule organisms; a few corn and grain seeds; 2 grams each of nitrate of soda and sodium acid phosphate; a few hundred alfalfa seeds; and alfalfa inoculation soil or culture.

**To Study the Effect of too Much Water on Plant Growth in Relation to Nitrification.**—*Procedure.*—Plant 3 one-gallon crocks of sandy loam, or loam taken from the field, to corn and small grain. Water them and keep them under the same favorable growing conditions. To crock No. 1 apply 2 grams each of dissolved sodium nitrate and sodium acid phosphate (to enrich the soil). When the plants are about 3 to 4 inches high, treat them as follows:

Crock No. 1—Keep flooded with water.

Crock No. 2—Keep flooded with water.

Crock No. 3—Water normally.

Start moisture treatments all at the same time. Continue these treatments for at least 2 weeks, or until results are definite.

*Questions.*—(a) Why did the plants in crock No. 2 turn yellow so soon?

(b) Explain the results secured in crock No. 1.

(c) Define nitrification.

(d) Name conditions in the field that favor nitrification.

**To Demonstrate the Importance of Inoculation.**—*Procedure.*—Fill two one-gallon crocks with soil free of alfalfa nodule organisms. Provide proper conditions in each crock for growing alfalfa. Inoculate one crock, but do not inoculate the other. Seed both crocks to alfalfa, water, and observe results.

**Field Studies.**—Observe nodules on the roots of clovers and other legumes. Do not pull roots but dig them, and rinse off the soil in water.

Examine the roots of "yellow" alfalfa, and of vigorous plants for nodules.

**Home Experiment.**—It would be of interest as a home experiment to plant two strips side by side of some legume not commonly grown in the community. One of the strips should be inoculated, and the other left uninoculated. (Consult text.) Note results in nodule development and in yield.

## QUESTIONS

1. Name the different classes of soil organisms. What are microorganisms? Tell of their number in soils.
2. Into what three classes may the helpful soil organisms be grouped?
3. What becomes of all dead organic material? Of what importance is this fact?
4. How is it possible that the nitrogen in organic matter becomes available?
5. From what main source does a crop like corn get its nitrogen? Its mineral elements?
6. Explain why the fertility of some light-colored soils rich in the mineral elements may be increased just by plowing under a crop of green rye.
7. Upon what depends the value of an organic fertilizer, like dried blood? Of some insoluble mineral fertilizer, like rock phosphate?
8. Explain by aid of a diagram how plants are able to secure nitrogen from the organic matter in soils. What is the meaning of nitrification?
9. What becomes of the nitrates formed as the result of nitrification?
10. What do "catch crops" catch? Why are some crops called "cover" crops?
11. Does the process of nitrification increase the nitrogen content of soils? Explain.
12. What is meant by denitrification?
13. How may the beneficial effect of manure on peat and muck soils be partly explained?

14. What is meant by nitrogen fixation in soils? How else is nitrogen fixation accomplished?
15. What are the main differences between legumes and non-legumes?
16. From what sources do legumes get their nitrogen?
17. How much nitrogen may be added to the soil by the free nitrogen-fixing organisms?
18. Tell how the nodule bacteria work.
19. How much nitrogen may be added to the soil on a farm in growing clover? In growing alfalfa?
20. Explain why, under like conditions, corn should yield better on clover sod than on timothy.
21. Discuss the relation of crop failure to a lack of nodule bacteria. Why is it necessary that legumes should have these nodule bacteria?
22. What is the meaning of soil inoculation? Cross inoculation? Illustrate.
23. Suppose a field is to be inoculated for alfalfa; explain how it should be done.
24. If, after growing alfalfa, soybeans are to be grown, would inoculation be necessary for soybeans? Why?
25. How often should inoculation for the same legume be made?
26. Have you ever seen legumes that probably needed inoculation?
27. What are the soil conditions favorable to the growth and activity of the helpful soil organisms?
28. For an outline summary of this chapter, see table of contents.

## CHAPTER XII

### NITROGEN, PHOSPHORUS AND POTASSIUM IN RELATION TO SOIL FERTILITY

**An Important Controllable Factor.**—“Sufficient available plant-food elements” is a fifth positive factor determining soil fertility (Chapter VII). The maintenance of fertility may be



FIG. 123.—Feed the soil and you feed the crop. When this peat soil was supplied with the necessary elements of plant food this splendid crop of corn was the result.

accomplished in a large measure by maintaining in the soil a good available supply of the important elements (Fig. 123).

Outside the irrigated sections the source of “water” is the rainfall; thus, so far as the farmer is concerned, the water problem is mainly a question of conserving and controlling this moisture for crop use. As regards “air,” it is free and abundant—and the supply of carbon dioxide contained in it remains practically the same. With drainage and good tillage a lack of air in the soil need never be a cause, either directly or indirectly, of low yields. “Good tilth” can neither be bought nor sold, leached out of the soil or

added to it. It is a soil condition that good soil management maintains and poor management destroys. "Helpful soil organisms" perpetuate themselves, and they remain in the soil so long as the farmer maintains soil conditions favorable to them. But as regards the "plant-food elements," a virgin soil may become depleted, and crops consequently fail. Moreover, some soils are unproductive because they especially lack some one essential element (Chapter VI). The only way to restore a depleted supply



FIG. 124.—Sixty-four bushels of potatoes for nine dollars. When a necessary fertilizer was added to this soil a 64 per cent increase in yield was obtained.

of elements, or to nullify the effect of a lack of any one or two elements, is to add plant-food material to the land (Fig. 124). It is entirely possible for the farmer to add fertilizing elements to the soil, and to maintain in the soil a sufficient available supply, so that his efforts concerning moisture conservation, aëration, tillage, etc., shall not be in vain. Compare Figures 125 and 126.

Of the elements essential to plant growth, four are much discussed in relation to crop production, viz., nitrogen, phosphorus, potassium, and calcium (lime).<sup>1</sup> Since the liming of soils is so

<sup>1</sup> Commonly, the word "lime" is used instead of calcium, though it is the oxide of calcium (CaO).



FIG. 125.—Sixty-nine and one-half bushels of oats per acre. Unfertilized. (See Fig. 126.) Bundles represent growth on one square rod. (Wisconsin Station.)



FIG. 126.—Eighty-seven bushels per acre when fertilized with three hundred pounds of acid phosphate per acre. (Wisconsin Station.)

important a subject, it will be discussed in a chapter by itself. In this chapter special consideration will be given nitrogen, phosphorus, and potassium.

**Substances Contributing to the Supply of Available Plant-food Elements.**—When the pioneer farmer tilled the virgin soil, he reaped bountiful harvests of corn and grain—not for one year only, but for many years. What contributed to the crop needs of nitrogen and mineral elements? Three substances, viz.:

- (a) A small amount of soluble salts in the soil.
- (b) Organic matter.
- (c) Mineral soil particles.

As time went on, crop yields fell off, and the farmer began to realize that soils can become “exhausted” or “worn out.” From times immemorial tillers of the soil have been advised to keep up the “strength” of the land by adding substances to it. Herein lies the theory of fertilizers. The process of adding fertilizing elements to the soil or rendering available the elements present in the soil is *fertilization*. The substances commonly used to add fertilizing elements to the soil, or to render available those already there are:

- (a) Vegetation and crop residue, as roots, stubble, straw, etc.
- (b) Green crops plowed under (green manuring).
- (c) Commercial fertilizers.
- (d) Manure.

Vegetation produced the organic matter found in virgin soils. Its value is well known. All plant residue such as roots, stubble, etc., aids materially in maintaining the organic matter. Thus leaf mold, grass, etc., should always be plowed under wherever possible, and not burned.

The further discussion in this chapter will be under three main headings: (1) Green Manuring; (2) Commercial Fertilizers, and (3) Manures.

#### GREEN MANURING

**Green Manuring and Its Benefits.**—Green manuring is the plowing under of green crops for soil improvement. The benefits to be derived through this practice are: The organic matter may be maintained; nitrogen is added to soils, in case of legumes; the available supply of nitrogen and mineral elements is increased; soil structure is improved; the development of good tilth through tillage is made easier; and soils become less difficult to work. Some green manuring crops may also serve as catch and cover crops.

Legumes are the best crops to use whenever possible. In



southern California it was found that it required from 270 to 1080 pounds of nitrate of soda<sup>2</sup> together with a green manuring crop of barley to produce as good a yield of corn as when a legume was plowed under. In either case the same amount of organic matter was added.

In a test made in Canada, increases of twenty-eight per cent in potatoes and forty per cent in corn resulted in growing these crops following clover.

In Alabama the plowing under of a legume (cowpeas) gave a clear gain of 696 pounds of seed cotton per acre (Fig. 127).

A legume crop (crimson clover) plowed under in Maryland gave an increase of twenty-seven bushels in potatoes and seven bushels in corn (Fig. 128).

At the Virginia Truck Station, Norfolk, "cowpeas plowed under green in the fall gave as large a yield of cabbage per acre as twenty tons of stable manure."

On the better soils where good clover or alfalfa can be grown often, the need of a special green manuring crop is seldom felt.

**It is Necessary to Maintain Organic Matter.**—Many farmers fail to appreciate the necessity of replenishing the organic matter in soils, and too often clover is left out of the cropping plans. On many farms clover does not grow so well as it used to, or fails entirely. This should be taken as a warning that something is wrong with the soil or the system of farming. When clover is left out of the cropping system, and the organic matter of the soil is allowed to become depleted, it is only a question of a few years when the other crops will cease to give paying returns.

**An Old Practice.**—Green manuring to add organic matter and nitrogen is not a new farm practice. Its value has long been known. Twenty centuries ago Varro told the Roman farmers the following:



FIG. 127.—Cowpea. (U. S. D. A.)

<sup>2</sup> A soluble nitrogen fertilizer.

“Certain things are to be sown, not with the hope of any immediate profit being derived from them, but with a view to the following year, because being plowed in and left in the ground, they render the soil afterwards more fruitful.”

**Crops for Green Manuring.**—Many crops may be used for plowing under: legumes, rye, buckwheat, rape, oats, etc. The



FIG. 128.—A, Hairy vetch. B, Crimson clover. (U. S. D. A.)

clovers and vetch (Fig. 128) can be seeded one year with grain and turned under in the fall or in late spring. Alsike clover is suitable for low lands. Mammoth clover is well adapted for poor soils to get rank growth.

Cowpeas, soybeans (Fig. 129), rape, and crimson clover<sup>3</sup> may be sown in between the rows when a cultivated crop is “laid by.”<sup>4</sup>

<sup>3</sup> Crimson clover is commonly grown as a green manuring and forage crop along the Atlantic seaboard from New Jersey to the Gulf States.

<sup>4</sup> “Laid by” means last cultivation.

When the crop is harvested, the cowpeas, clover, etc., serve as catch crops, and are plowed under later in the fall. Cowpeas, soybeans, common vetch, field peas, and velvet beans are the legumes best adapted to single summer growth. Sweet clover is a biennial (Fig. 130).

Green manure is much needed in the South. There each year the season is long enough to permit the growing of one or two crops for sale and at least one crop for plowing under. For this reason soybeans, cowpeas and velvet beans are used more than any other crop.



FIG. 129.—Soy beans.  
(U. S. D. A.)



FIG. 130.—Sweet clover.  
(U. S. D. A.)

**Plowing Under the Crop.**—Generally, the best time to plow under a legume crop is when it is still green. Rye, or any other grain crop, should be turned under before it becomes too strawy.

Sometimes when a heavy growth is plowed under at the beginning of a prolonged dry period, injury results, because of the drying out of the seed bed. In such cases, good contact should be created, if possible, between the seed bed and the subsoil. In this, good plowing is advantageous (Figs. 75 and 76).

It is always best to turn the green crop immediately under. In this work jointers and coulter are useful (Fig. 74). A chain may also aid in getting the growth turned under the furrow slice (Fig. 131). Sometimes disking before plowing is helpful.

**Green Manures for Cultivated Crops.**—It is a general practice to follow green manures with cultivated crops such as corn, cotton,



FIG. 131.—Turning under weeds with the aid of a chain.

cane, tobacco, potatoes, etc. Cultivation favors the decomposition of the green crop, thereby rendering available more plant-food elements.

**Green Manuring Necessary in Soil Improvement.**—In practically all soil improvement plans, green manuring occupies an important place. In some cases the growing and plowing under of a crop of buckwheat proves the best method in making possible the regeneration of very poor or exhausted soils. Many sands are so poor that rye is the only possible first crop. When the rye crop is plowed under, it makes possible the growing of other green manuring crops, as soybeans, cowpeas, or mammoth clover, which,

together with lime and certain fertilizers, make productive *sands* a reality.

The improvement of the lighter colored and long-cropped soils is dependent upon the addition of organic matter and nitrogen. This becomes a primary object, and whatever other soil treatments are necessary, they are made not only to produce the organic matter, but at the same time to benefit all other crops.

In Australia many soils are so poor that they are incapable of producing a paying crop; but when cowpeas are grown and plowed under, these soils can be regenerated.

**Feeding vs. Plowing Under Crops.**—The question often arises, "Is it not better to feed the crop than to plow it under?" This is to be determined by the good judgment of the farmer. If the soil is a black loam, or a black silt loam, and is in a good state of fertility, feeding the crop and returning the manure, no doubt, is the better practice. On the other hand, if the addition of organic matter and nitrogen is the key to the improvement of any soil, then plowing under the crop would be the better plan. In this respect the advice given by Varro is still good today.

In many cases when a farmer has sufficient hay and a good second growth (rowen) comes on, this second growth may better be turned under than be cut for hay or allowed to go to seed.

**Some Hints on Green Manuring.**—In the regeneration of very poor soils, it is necessary to plow under the year's crop to make improvement possible. In such cases the crop is sacrificed for the good of the land. Under good soil management, it is not necessary to lose a crop in order to be able to grow green manure.

When two grain crops are grown in succession, the first crop may be seeded to mammoth clover which is plowed under in the fall. The second grain crop is then seeded with medium, alsike, or crimson clover for hay or pasture to follow the grain.

In potato sections, rye may be scattered over the field at harvest time, the digging covers the seed, and the growth is plowed under in the spring, previous to planting. Or the rye may be seeded to clover, the rye cut as a cash crop, and the clover plowed under for the potato crop the following year.

A green manuring crop may be planted in between the rows of a cultivated crop at the last cultivation, and plowed under in the fall.

Sometimes a rank growth of weeds may prove very effective as a green manuring crop.

## COMMERCIAL FERTILIZERS

Commercial fertilizers are manufactured preparations used to add plant-food elements to the soil, particularly nitrogen, phosphorus and potassium. These elements in fertilizers are commonly expressed as "nitrogen (N)," "phosphoric acid ( $P_2O_5$ )," and "potash ( $K_2O$ )," respectively. Nitrogen (N) is sometimes expressed as "ammonia ( $NH_3$ )." To avoid any misconceptions, the names of the elements are retained in this discussion.

Some substances, as common salt, for example, are called soil stimulants, or indirect fertilizers, because they do not contain any nitrogen, phosphorus or potassium, but cause changes in the soil liberating the plant-food elements already there.

**Four Classes of Commercial Fertilizers.**—Commercial fertilizers may be grouped into four classes, viz.: (a) Nitrogen fertilizers; (b) phosphorus or phosphate fertilizers; (c) potassium or potash fertilizers, and (d) mixed fertilizers.

**Nitrogen Fertilizers.**—The common nitrogen fertilizers are:

Common names	Per cent nitrogen	Availability
(a) Nitrate of soda, or sodium nitrate.	15	Very readily available.
(b) Ammonium sulfate, or sulfate of ammonia.....	20	Readily available.
(c) Dried blood, or blood meal.....	6-15	Becomes quickly available.
(d) Cottonseed meal.....	4-8	Nearly equal to dried blood.

Other nitrogen fertilizers are: Dried meat scraps, tankage, dried ground fish scrap, hoof meal, guanos, wool waste, peat, calcium cyanamid, calcium nitrate, and others.

**Nitrate of Soda.**—The best known and most widely used nitrogen fertilizer is nitrate of soda. This is a salt obtained from natural deposits found particularly in northern Chili. The origin of this large deposit is not definitely known.

Nitrate of soda can be utilized directly by plants without first undergoing decomposition changes. Because of its solubility and the ease with which it is leached from the soil, the amount applied to the acre at any one time is not very large. The usual application is from 100 to 400 pounds applied in frequent small amounts during the early growing period. It is often used in small quantities to force plant growth, as on tobacco beds. Market gardeners and truck growers use this fertilizer more than do general farmers, and it is used more extensively in the Eastern states than in the West.

**Ammonium Sulfate.**—Sulfate of ammonia is a salt made as

a by-product in the manufacture of coke and illuminating gas. In the soil this fertilizer undergoes decomposition and nitrification. It has been found that corn, peas and rice can use nitrogen directly from this salt. This fertilizer has about nine-tenths the efficiency of nitrate of soda, and it may be used in a similar manner. The use of ammonium sulfate will no doubt become more general than formerly, since the nitrate deposits are destined to exhaustion in a few generations.

**Dried blood** is the evaporated, dried and finely ground blood of slaughtered animals. This is one of the best organic nitrogen fertilizers. Under proper soil conditions it proves about ninety per cent as efficient as nitrate of soda.

**Cottonseed meal** is a product formed when oil is removed from cotton seed. The extracted residue is ground fine. It is extensively used as a fertilizer in the South.

This material, as well as all other available nitrogen-containing substances, are much used in the manufacture of mixed fertilizers.

**Legumes to Solve Nitrogen Problem.**—The demand of all crops for nitrogen is greater than for the other elements. (See Table of Crop Requirements, Chapter VI). This, together with the fact that the conditions of life in the civilized quarters of the globe are such as to cause a constant loss of nitrogen, has caused the question of the available nitrogen supply of the world to be looked upon as lying at the very foundation of agriculture, and to demand most careful consideration. One of the greatest problems in the maintenance of soil fertility is how to secure and keep a sufficient supply of available nitrogen at the least cost. This is too large a problem to be solved through the use of commercial nitrogen fertilizers alone. It is now generally agreed that legumes must play the larger part in the solution of the nitrogen problem. Moreover, it should be remembered that fertilizers can never become a substitute for the organic matter so essential in all soils.

**Phosphate Fertilizers.**—The common phosphate fertilizers are:

Common names	Per cent phosphorus (P)	Per cent phosphoric acid ( $P_2O_5$ )	Availability of phosphorus-containing ingredient
(a) Rock phosphate . . . . .	11.8 to 13.5	= 27 to 31	Insoluble.
(b) Basic slag, or Thomasslag	4.5 to 8	= 10 to 18	Less than bone meal.
(c) Ground steamed bone meal* . . . . .	10 to 11	= 23 to 25	Medium.
(d) Acid phosphate . . . . .	5.7 to 8	= 13 to 18	Readily available.

\* Ground steamed bone meal also contains 2 to 3 per cent nitrogen.

**Expressing Equivalents.**—The fertilizing constituent of phosphate fertilizers may be expressed in three ways: as “phosphorus (P),” as “phosphoric acid ( $P_2O_5$ ),” and as “bone phosphate of lime (BPL).” The per cent of “phosphoric acid” is always higher than the per cent indicating the phosphorus content of a fertilizer; and the per cent expressing the equivalent of bone phosphate of lime is higher still; to illustrate, thirteen per cent phosphorus (P) equals thirty per cent phosphoric acid ( $P_2O_5$ ) equals sixty-five per cent bone phosphate of lime (BPL).

Phosphoric acid ( $P_2O_5$ ) and bone phosphate of lime (BPL) may be reduced to the common elemental name as follows:

Per cent or pounds phosphoric acid  $\times 0.436$  = per cent or pounds of phosphorus, respectively. Per cent or pounds of bone phosphate of lime  $\times 0.2$  = per cent or pounds of phosphorus, respectively.

**Rock Phosphate.**—Rock phosphate is finely pulverized phosphate rock. The main sources of this fertilizing material in the United States are deposits in Tennessee, South Carolina, Florida, Arkansas, Kentucky, Utah, Wyoming, Montana and Idaho. Because of its insolubility, this fertilizer gives best results on most soils when it is mixed with manure or plowed under with a green manuring crop. On some muck and peat lands it has given very good results when applied directly to the soil and thoroughly mixed with it, at the rate of about 800 pounds per acre. In soil improvement plans, especially when the phosphorus supply is to be increased and maintained, it has been found good practice to mix rock phosphate with stall manure by sprinkling it in the gutters in the barn during winter feeding, at the rate of from fifty to one hundred pounds to the ton of manure produced. This is equivalent to approximately two to four quarts to the cow daily. Rock phosphate may also be dusted over the manure when loaded on spreaders.

**Basic slag, or Thomas slag meal,** is pulverized slag of Bessemer steel converters. The phosphorus is withdrawn from the molten phosphorus-containing iron. This fertilizer is much used in European countries and to a certain extent in eastern United States—it being imported from Europe. The phosphorus-containing iron ore in Alabama, which is being converted into steel, may prove a valuable source of this fertilizer.

**Ground Steamed Bone Meal.**—This fertilizer is pulverized steamed bone. The bones from meat-packing plants are steamed, or otherwise treated, to remove the fat and sometimes the gelatine



also. After the extraction, the bones crumble readily and are easily ground. Bone meal is a much-used fertilizer, especially by truck gardeners. About 100 to 300 pounds and more may be applied per acre.

**Acid Phosphate.**—Acid phosphate is made by treating an insoluble phosphate with an acid and thereby changing it into a soluble phosphate. This is the most easily soluble phosphate fertilizer. The name "superphosphate" is sometimes applied to it. The manufacturing process consists mainly in treating rock phosphate with sulphuric acid. Because of its availability, or solubility, acid phosphate is very generally used, especially when immediate results are desired. Applications may vary from 100 to 500 pounds per acre.

**Many Soils Need Phosphates.**—Many soils are particularly deficient in phosphorus, either because they never contained any appreciable supply, or because of exhaustive cropping. Phosphorus deficiency is especially prevalent in sections where, during the early days, wheat was the one crop raised. So far as the soil is concerned, that was a period of most wasteful farming.<sup>5</sup> Nothing was returned to the land, the grain and other products were sold, and the straw was burned. The organic matter was rapidly used up and the phosphorus was carried away with the wheat. The only way to correct this phosphorus deficiency and to maintain a sufficient supply in the soil is to buy phosphorus and add it to the land. Phosphorus may be purchased in the form of fertilizers and, to a lesser extent, in the form of feeds, such as bran, for example. The feeds when fed enrich the manure produced.

It is common experience to obtain crop increases of from ten to fifty per cent and more by using phosphate fertilizers. The important effects produced by supplying sufficient phosphorus are: (a) The grain fills better and consequently weighs more per unit volume; (b) plants develop strong and extensive roots, and (c) crops often mature earlier.

In general, the following soils are benefited by phosphate fertilizers: Soils exhaustively cropped, peat and muck soils, sands, and black, acid loams, and silt loams.

**Available Phosphate More Important Than Total.**—The amount of phosphorus that crops can secure is of more importance

---

<sup>5</sup> The pioneer wheat-farmer can hardly be blamed for his system of farming. The fact that the soils were rich enough to grow good crops of wheat made possible the construction of roads, the building of cities, and general developments which are enjoyed today.

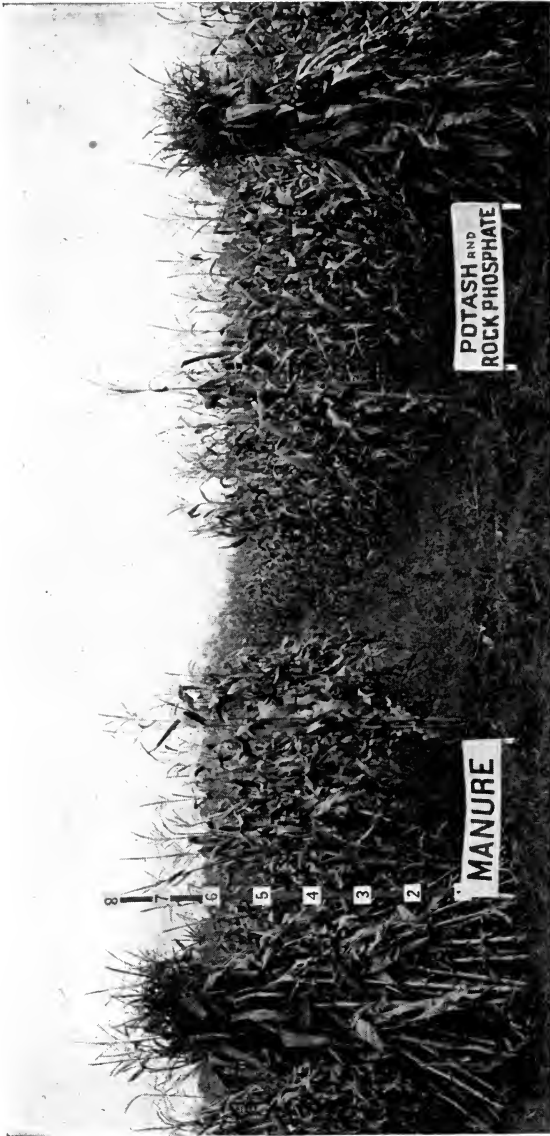

Fig. 132.—Rock phosphate and potash compared with manure on marsh land. The mineral fertilizer proved more economical. (Wisconsin Station.)

than the "total" amount contained in soils. Some soils may contain a very good supply but still respond to phosphate fertilization. Other soils containing lower amounts may give no indication of phosphorus deficiencies. When a silt loam, for example, has had its original phosphorus supply reduced one-third to one-half, and is in need of phosphates, it is not necessary to add an amount of fertilizer to raise the phosphorus content to the original amount, but to fertilize sufficiently to enable the soil to furnish the phosphorus demanded by profitable crops.



FIG. 133.—What happened when the fertilizer missed. This particular peat soil responds best to a mixture (1 to 1) of muriate of potash and acid phosphate.

**The Choice of Phosphates.**—When immediate results are desired and when top-dressings are to be made, a soluble fertilizer should be used. Acid phosphates, or superphosphates, are, therefore, especially adapted to all cases where spring top-dressing is practiced; as, for example, on grass land, for clover, alfalfa, and winter grains.

Bone meal gives excellent results on soils that are open and inclined to be sandy or gravelly.

Rock phosphate has given good results on peat and muck soils and on upland soils exceptionally rich in decomposable organic matter. Compare Figures 132 and 133.

Basic slag, bone meal and rock phosphate are good fertilizers to use for crops like corn, grain, and potatoes, when grown on acid soils. Basic slag acts well on clayey soils.

For plants and soils which need liming, phosphates give more economical returns when lime is added to the land. This is particularly true in case of acid phosphates.

**Rock Phosphate vs. Acid Phosphate.**—The comparative fertilizing values of rock phosphate and acid phosphate have been much discussed. Most available data seem to indicate that, in general, acid phosphate is the more profitable.<sup>6</sup> On some of the black prairie soils of the Middle West, certain results have shown that rock phosphate is to be compared favorably with acid phosphate.

**Potash Fertilizers.**—The common potash fertilizers are:

Common names	Per cent potassium (K)	Per cent "potash" (K <sub>2</sub> O)	Availability
(a) Muriate of potash, or potassium chloride.....	41.5 to 44	50 to 52	Soluble.
(b) Sulfate of potash, or potassium sulfate.....	40 to 42	48 to 51	Soluble.
(c) Kainit.....	10 to 12	12 to 14.5	Soluble.
(d) Wood ashes.....	2 to 10	2.5 to 12	Potash soluble.

The fertilizing constituent of potash fertilizer may be expressed either as the element potassium (K), or as the oxide of the element "potash" (K<sub>2</sub>O). To reduce "potash" to the element equivalent, multiply the number of per cent or pounds of "potash" by 0.83.

**Sources of Potash.**—The main source of potash fertilizers is crude salts mined near Strassfurt, and in Alsace. No other deposits of potassium salts are so extensive as these. It has been estimated that the Strassfurt mines alone are capable of supplying the world with potash for thousands of years.

There are several sources of potassium in the United States, among which are: Dried-up salt lakes, sea weed, wood ashes, potassium-containing rock minerals, and as a by-product in cement manufacture. The potassium salts obtained from these sources have thus far been used in making mixed fertilizers. Tobacco stems used as potash fertilizer are shown in Figure 134.

**Muriate of Potash.**—Muriate of potash is a prepared product derived from crude potash salts. This is the most common of the potash fertilizers. It is all soluble in water.

<sup>6</sup> This conclusion is based on prices paid for fertilizers before the World War.

**Sulfate of Potash.**—This is another product derived from crude potash salts. It is not so generally used as the muriate. This fertilizer is likewise all soluble in water.

**Kainit** is a crude potash salt, unprepared except by grinding. It is water soluble, and is used mainly in the making of mixed fertilizers.

**Wood ashes** vary in the amount of potassium they contain. Thoroughly leached ashes are of little or no value as a potash fertilizer. Hardwood ashes are generally richer in potassium than those of soft woods. Woods burned at high heat produce ashes much lower in potassium than when burned at low heat, as in a kitchen



FIG. 134.—Tobacco stems are a good potash fertilizer.

range. In addition to potash, wood ashes contain from fifty to seventy per cent carbonates of lime and magnesia.

**Use of Potash Fertilizers.**—Peat, muck and sands are soils particularly in need of potash fertilizers. Though the heavier soils contain an abundant supply of potassium, yet some of them respond to potash treatment. Crops demanding an abundant supply of potassium are: Sugar beets, clovers, alfalfa, cabbage, tobacco, turnips and corn (Figs. 135 and 136).

For most soils needing potassium, muriate of potash is suitable and the cheapest. From 100 to 200 pounds to the acre per year, applied broadcast, is the usual application of either the muriate or sulfate for corn, turnips, potatoes and clover; and from 200 to 300 pounds for onions, cabbage and sugar beets.

Certain results seem to indicate that sulfate of potash produces a better quality of potatoes and tobacco than the muriate. Other results show that when soil conditions are right as regards car-

bonate of lime and moisture, the muriate may give as good results as the sulfate.

Kainit is much used in the South.

FIG. 135.



FIG. 136.



FIG. 135.—For corn (in a pot test) this peat soil responded to phosphate treatment. *O*, no treatment; *N*, nitrogen fertilizer; *P*, phosphate treatment; *K*, potash; *PK*, phosphate and potash. (See Figure 136.)

FIG. 136.—For cabbage, potash fertilizer gave the greatest response. Same soil as in Figure 135. *A*, response to phosphate; *B*, response to potash.

Wood ashes are excellent for acid, peat soils. From one to two tons per acre is a common application.<sup>7</sup> No mixture of commercial fertilizers gives the results on acid marsh soils as do ashes.

<sup>7</sup> When containing 30 to 40 per cent moisture.

**Mixed Fertilizers.**—Commercial fertilizers containing nitrogen, phosphorus and potassium are called mixed fertilizers. Those containing all three of the fertilizing elements are called “complete” fertilizers. In this respect, manure is to be regarded as a complete fertilizer.

Hundreds of brands of mixed commercial fertilizers are to be found on the market—sold under various trade names; such as, Corn and Cotton Grower, Dreadnaught Fertilizer, Prolific Crop Producer, etc. These fertilizers are commonly spoken of in terms of the per cents of the fertilizing constituents contained in them; for example, a mixed fertilizer containing two per cent nitrogen (N), twelve per cent phosphoric acid ( $P_2O_5$ ) and two per cent potash ( $K_2O$ ) is called a “2-12-2” fertilizer.<sup>8</sup> A “0-12-4” fertilizer means one containing no nitrogen (N), twelve per cent phosphoric acid ( $P_2O_5$ ) and four per cent potash ( $K_2O$ ).

The following shows the meaning of some mixed fertilizers in terms of the elements:

Per cent nitrogen (N)	Per cent phosphoric acid ( $P_2O_5$ )	Per cent potash ( $K_2O$ )	Per cent nitrogen (N)	Per cent phosphorus (P)	Per cent potassium (K)
4	8	4	4	3.5	3.3
2	12	2	2	5.2	1.7
0	10	8	0	4.4	6.6

**Use of Mixed Fertilizers.**—Mixed fertilizers are very generally used. Applications vary from 50 to 1500 pounds and more to the acre. It is better to purchase these fertilizers on the basis of what they contain rather than because of their names.

**Commercial Fertilizers in General.**—Many erroneous ideas are prevalent regarding the use of commercial fertilizers, especially in sections where fertilizers are little used or practically unknown. Some believe they injure the soil, and that when once used their use must be continued. It is not because the “soil gets a bad habit” that many farmers continue the use of fertilizers, but because of profitable returns. Fertilizers sometimes fail for the following reasons: The wrong kind of fertilizer may have been used; it may have been applied in the wrong manner; the soil may lack proper underdrainage, and there may have been a deficiency of moisture.

<sup>8</sup> In some Southern states phosphoric acid is usually mentioned first, then nitrogen and potash. A “10-4-3” fertilizer in those states means, therefore, 10 per cent phosphoric acid, 4 per cent nitrogen and 3 per cent potash.

No farmer, however successful, should ever think of trying to maintain the fertility of his soil through the use of commercial fertilizers alone. Legumes, grass, green manuring crops and barn-



FIG. 137.—Four rows without fertilizer in the drill. To the left and right 125 pounds of a 1-8-1 mixed fertilizer were applied per acre in the drill with a fertilizer attachment on the planter. (See Fig. 138.)



FIG. 138.—An eighty-one per cent increase in silage corn at harvest time. To left, unfertilized, 8.7 tons per acre; to right, fertilized, 15.8 tons per acre. A long-cropped soil.

yard manure are indispensable. Except for truck crops and potatoes, it is wise economy to use commercial fertilizers in a definite plan of more permanent soil improvement and fertility maintenance rather than to make light applications mainly to stimulate



the one crop to which it is applied. Though it may be good business practice to apply fertilizers to a crop and increase the net profits, yet it is still better practice to accomplish this in such a way as to effect a more permanent improvement of the soil, which will serve to benefit several crops in succeeding seasons.

**Profits Determine Use of Fertilizers.**—The use of commercial fertilizers depends mainly upon whether or not the value of the increased yields more than offset the cost of the application (Figs. 137 and 138). On many soils the use of commercial fertilizers does not pay (Fig. 139). The best returns from fertilizers are



FIG. 139.—Corn stimulated by complete fertilizer applied in the hill (125 pounds per acre). No appreciable difference in yield at harvest time. Soil in good state of fertility. (See page 208.)

obtained when soils are sufficiently supplied with moisture and organic matter (compare Figs. 140 and 141).

The cost of fertilizers varies in different sections, depending largely upon the distance from distributing centers. Fertilizers are usually purchased on the unit basis. One per cent of a ton, or twenty pounds, is called a unit. Normal prices for nitrogen have been about three dollars per unit; phosphoric acid ( $P_2O_5$ ) from twenty to forty-five cents in rock phosphate, and about one dollar in soluble phosphates; and potash about one dollar to one dollar and forty cents per unit.

The World War had a decided effect on fertilizer prices. The price paid for nitrogen was six to seven dollars per unit; soluble

phosphoric acid about two dollars, and "potash" seven dollars and more per unit.



FIG. 140.—Corn responded during early growth to about 100 pounds of a mixed fertilizer (1-8-1) applied in the drill. (See Fig. 141.)



FIG. 141.—No appreciable difference in the yield at harvest time, because the land was well manured. Same field as shown in Figure 140.

**Soils and Crops Determine Kind of Fertilizer to Use.**—The soil supply of the available plant-food elements and the kind of

crop to be grown are two factors determining largely the kind of fertilizer to use (Figs. 135 and 136). The growing of sugar beets on peat, for example, requires liberal applications of a potash fertilizer. The forcing of lettuce and other garden crops requires an abundant supply of available nitrogen (Fig. 142). The application of soluble phosphate fertilizer on many soils proves the most profitable fertilizer treatment, especially on long-cropped prairie soils. The improvement of poor soils generally requires the addition of all the fertilizing elements.



FIG. 142.—Making a second application of fertilizer to head lettuce. The fertilizer is scattered along the rows and stirred in. (N. Y.)

Mixed or complete fertilizers in comparison with single fertilizers commonly give the highest average increases and profits. This is particularly true in case of wheat, potatoes and cotton. Frequently a mixture of phosphate and potash gives best results. Many experiments have shown that the full effect of one fertilizing element is obtained only when it is associated with the other two. Moreover, the addition of phosphorus and potassium usually increases the need of nitrogen for bigger crops. In other tests a fertilizer, either single or complete, used in conjunction with a green-manuring crop is the best means to obtain higher crop yields.

These results show that the plant, as well as the animal, requires a "balanced ration" to enable it to use its food materials most economically. This emphasizes the necessity of keeping a balanced condition in the soil in regards to the fertilizing elements.

No general rule can be given for fertilizing soils, since conditions are so variable and soils differ so widely in their characteristics. A certain fertilizer may prove a "best fertilizer" for one soil, while on another it may be of no value whatever. The only sure way of determining the fertilizer needs of a crop on any particular soil is by actual field tests. How the fertilizer needs of soils and crops may be determined is discussed fully.

**High Grade Fertilizers More Economical.**—High grade fertilizers are usually considered as those containing a relatively large amount of plant-food elements. Another distinction is: High grade fertilizers are made of high grade, standard materials like nitrate of soda, ground bone, acid phosphate, muriate and sulfate of potash. The low grade preparations, on the other hand, are usually made by mixing cheaper, inferior and less soluble materials, like low grade tankage, wood ashes, kainit, peat, etc. When the amount and quality of the fertilizing ingredients, freight, and cost of handling are considered, the high grades are the cheaper.

**Home Mixing of Fertilizers.**—By home mixing is meant the mixing of purchased fertilizing materials on the farm. This is commonly recommended, because the cost per pound of plant-food elements is lowered, mixtures can be varied to suit particular soils and crops, and better knowledge is obtained concerning kinds and quality of different materials carrying fertilizing elements.

*The mixing operation is simple.* A clean floor, one or two shovels, a pair of scales, and a sand sieve having about four meshes to the linear inch is all the apparatus needed. The materials are first weighed out and placed in a pile on the floor—the bulkiest material at the bottom. All lumps are broken with the shovel. The pile is then shoveled over about three times, and the mixture passed through the sieve. Lumps are broken and added to the mixture, which is again shoveled over, if necessary, until thoroughly mixed:

**Home Mixing Rules.**—The following rules may be helpful in home mixing:

(a) Determine the number of pounds of each fertilizing element contained in one ton or any other amount, of the proposed mixture.

(b) Determine the number of pounds of the materials required to furnish these amounts of plant-food element.

(c) Add the amounts of the materials required to make the mixture, and, if the sum is less than 2000 pounds, or less than the required amount, add enough fine, dry muck, or any other inert material (filler) to make a ton, or the required amount of the mixture.

*An illustration:* Out of nitrate of soda (fifteen per cent N), acid phosphate (seven per cent P) and muriate of potash (forty-two per cent K) a complete 3-10-3 fertilizer is to be compounded, or one containing three per cent nitrogen, 4.4 per cent phosphorus and 2.5 per cent potassium.

(a) One ton of the proposed fertilizer contains sixty pounds of nitrogen, eighty-eight pounds of phosphorus and fifty pounds of potassium.

(b) Amounts of materials required per ton are: 400 pounds of nitrate of soda, 1260 pounds of acid phosphate, and 120 pounds of muriate of potash.

(c) The total amount of materials required is 1780 pounds; 220 pounds of filler are required to make the mixture equivalent to a ton.

**Materials Unsuitable for Mixing Together.**—Some mixtures are to be avoided. These are shown here.

Lime Wood ashes Basic slag	}	should not be mixed with	{	Acid phosphate Dissolved bone Sulfate of ammonia Tankage, blood meal, etc. Manure
----------------------------------	---	--------------------------	---	---

**How Fertilizers are Applied.**—Fertilizers may be applied broadcast, in the hill or drill, in the bottom of furrows, beside the rows after the plants are well above ground, and mixed with manure. In orchards and for crops whose roots are broadly distributed, the greatest part of the fertilizer, at least, should be applied broadcast before the crop is planted or before harrowing. When applied broadcast a much heavier application is usually made than when applications are made in other ways. About 100 to 300 pounds are common applications for grain; 200 to 500 pounds for grass and corn; 500 to 1000 pounds for orchards; 300 to 1200 pounds for root crops and tubers; and 500 to 1200 pounds for vegetables and truck crops. The fertilizers applied in the hill or drill, and those used when heavy applications are made, are generally mixed or complete fertilizers.

When much fertilizer is applied, fertilizer distributors are used. All good makes of grain drills have fertilizer attachments for distributing fertilizer broadcast at the time of sowing.

When fertilizers are intended to promote rapid growth or to give the young plants a quick start, they are applied in the hill or drill. This is usually done through the use of fertilizer attachments on the planters (Fig. 143). Usually 100 to 200 pounds are applied to the acre in this manner. In case of cotton, 400 and 500

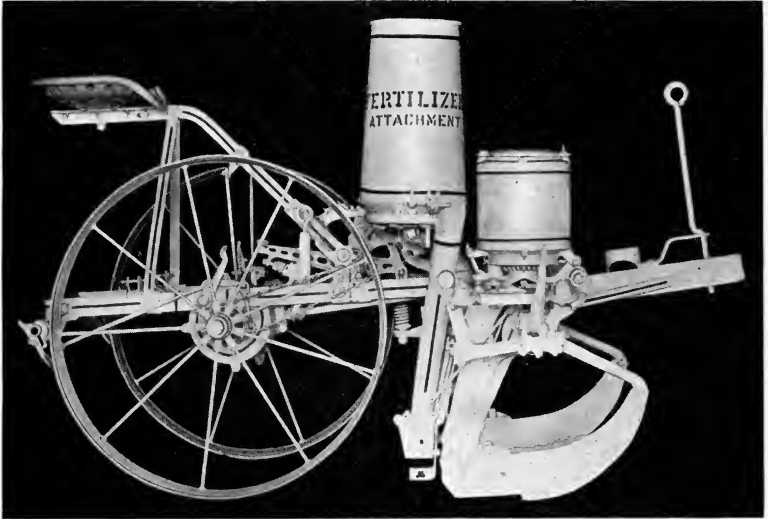

FIG. 143.—A fertilizer attachment on the corn planter. Note the fertilizer spreader (S).

pounds are common applications. In Maine as much as 2000 pounds per acre is sometimes applied in the row at the time of planting potatoes.

When fertilizers are applied in the hill or drill, special care should be taken that the fertilizer is not dropped on the seed. All good fertilizer attachments can be regulated so that soil will fall in between the fertilizer and the seed, or the fertilizer distributed along the sides of the row and not on the seed (Fig. 143). When fertilizer is applied in the bottom of a furrow it should be mixed thoroughly with the soil before the seeds are planted.

The higher the grade of fertilizer the greater must be the precaution in applying it in the hill, drill or furrow.

In some cases the greater portion of the fertilizer is applied broadcast, and a little is dropped in the hill or drill to promote quick growth. Because nitrate fertilizers are easily leached away, they are commonly applied beside the rows after the plants are well up (Fig. 142). This method of application is also used at times whenever fertilizers are not at hand to be applied otherwise.

**Lasting Effect of Commercial Fertilizers.**—In all liberal fertilization a residual or after-effect is secured on the crops following—often extending through three and four years or more. Results from broadcast distribution are the most favorable. Often the growth and ripening of grain is very uneven when it follows a cultivated crop fertilized in the drill or hill.

In this connection it is of interest to mention the absorptive power of soils for the fertilizing elements. Nitrogen in the form of nitrates is easily leached out of the soil. Nitrogen in the form of ammonia ( $\text{NH}_3$ ) in ammonium compounds, such as sulfate of ammonia, is usually readily absorbed by soils in such a way that it is less subject than nitrates to immediate losses by leaching. As regards phosphorus and potassium, these elements are readily absorbed and retained by soils, the heavier types having greater absorptive power than sandy soils. Practically all the phosphorus and potassium, therefore, added in commercial fertilizers, and which is not used by the crop fertilized, increases the soil supply, and is drawn upon by succeeding crops.

#### BARNYARD MANURE AS A FERTILIZER

Barnyard manure, farm manure, or stall manure generally means the waste materials from the care of livestock. In some sections it is the only, or the most important, fertilizer used. The best results with manure, as with any fertilizer, depend upon how intelligently it is used. There are many facts to be learned about manure. In the following few paragraphs are mentioned some important facts about it, and after that are discussed some practical pointers concerning its care and use.

**Some Facts About Manure.**—A ton of average, mixed yard manure contains approximately ten pounds of nitrogen, two pounds of phosphorus and eight pounds of potassium. When nitrogen is valued at fifteen cents a pound, phosphorus at ten cents and potassium at eight cents, one ton of such manure has an intrinsic

fertilizing value of \$2.34. When fertilizer prices were greatly advanced by the World War, a ton of ordinary manure had a value of about eight or nine dollars.

The value based on the returns from a ton of barnyard manure under average, general farming conditions is usually higher than this—depending on the soil, method of cultivation and crops grown. The returns per ton of yard manure on poor soil amounted to \$4.69 in a five-year test made at the Ohio Station. Corn, oats, wheat, clover and timothy were the crops grown. Eight tons of manure were applied to the acre—four to the corn and four to the wheat. On some farms manure is regarded more as a waste product only to be gotten rid of (Fig. 144). Usually, however, it is given a value of from one dollar to one dollar and a half a ton. On most dairy farms the value of the manure produced much more than offsets the labor cost of feeding and caring for the herd (milking not included). The annual total labor cost per cow is figured at sixteen to twenty-three dollars, and the value of manure produced at twelve to seventeen dollars. (Manure at about a dollar and a half per ton.)

**Manures Differ in Fertilizing Value.**—The accompanying table shows the composition of fresh manure produced by various farm animals.

*Composition of Fresh Manure*

(The figures give the number of pounds of fertilizing elements in one ton of manure, including liquid, solid and bedding.)

Animal	Average per cent water	Nitrogen (N)	Phosphorus (P)	Potassium (K)
Cow . . . . .	78	9-10	2.5-3	6-8
Horse . . . . .	63	10-15	2-3	8-14
Hog . . . . .	74	11-13	5-6	6-12
Sheep * . . . . .	63	27-34†	3.5-5	20-23
Hen † . . . . .	58	20	8	15

\* Made by fattening lambs.

† Average of four analyses from three states.

‡ Fed corn and clover hay.

**Feeding Affects Value of Manure.**—The kinds of feed fed an animal determine in a large measure the richness of the manure produced. If a cow were fed timothy hay only, the manure would be poor indeed as compared with that produced when a cow is fed alfalfa, bran, corn, etc. When cows are fed bran, the



manure produced is necessarily enriched in phosphorus (Feed table in Appendix).

**The age of the animal** also affects the value of manure. Growing animals remove much more elements, especially nitrogen and phosphorus, from the ration than do mature animals.

**The character and amount of bedding** and litter also have much to do in determining the value of manure. Sawdust and shavings add little or no value, and may even lower the value of manure.



FIG. 144.—Dollars are trickling from this manure pile into the pond. No farmer can afford to care for manure in this way.

The more bedding and litter incorporated with the excrement, the more bulky the manure becomes.

**Amount of Manure Produced by Farm Animals.**—Roughly speaking, it requires about twenty-five cows to produce a ton of manure in one day, including what is actually collected in the stables; about thirty-three to forty horses when kept in the stable all day, and about sixty when they are working; 160 hogs; and about 500 to 800 lambs when fed in the feeding pen.

**Liquid Portion of Manure Valuable.**—Of the total amounts of the fertilizing elements contained in manure, about one-half of the nitrogen and sixty per cent of the potassium are found in the liquid excrement. Thus, the liquid manure is practically as valuable in fertilizing elements as the solid. This fact emphasizes

the need of suitable absorbents to take up and conserve this valuable fertilizing material.

**Some Practical Pointers on Manure.**—The results secured in the use of manure do not come from the fertilizing elements only, but also from the organic matter and the organisms added. In one gram (one-fifth the weight of a nickel coin) of cow manure voided in the stable have been found from a million to 120 millions of organisms, and in horse manure from 100 to 150 millions.

**Manure a Quick Fertilizer.**—Manure has the quality of being



FIG. 145.—The manure from this dairy barn goes directly to the field.

a most effective fertilizer, largely because of the fact that it contains immediately, medium, and more slowly available plant-food material. About one-half of the nitrogen is soluble, about one-sixth of the phosphorus and about one-half of the potassium. This makes manure a good fertilizer to use as a top-dressing on pastures, hay land and clover and alfalfa fields.

**Stall Manure Better Than Open-yard Manure.**—Manure hauled directly to the field and there applied is twice to three times as valuable as that which has been allowed to accumulate in an open yard for a period of from three to six months. Large amounts of the fertilizing elements are leached out of open-yard manure by rains. No farmer can afford to follow the practice of throwing the manure carelessly from the stables into the open yard and there

allow it to become exposed to the weather and the water from the stable roof. Hauling it directly to the field or storing it properly is universally recognized as the only way to get full value from the manure produced.

**When Manure Has to Be Stored.**—It is not always convenient to haul it directly to the fields (Fig. 145). It then becomes necessary to store and conserve it for future use. Three points should be kept in mind in storing manure, viz.: (a) It should be kept moist; (b) it should be kept well compacted, and (c) any loss of



FIG. 146.—A manure spreader increases the returns per ton of manure. (Indiana Station.)

seepage water from the manure pile should be avoided. Losses of nitrogen from fermentation may be practically eliminated when a manure heap is kept moist and compact.

The covered manure shed is a popular method of caring for manure. Such a shed should be provided with a water-tight concrete floor and with sides sufficiently high to hold the manure in. This may be called a manure pit. It should be so built that a manure spreader (Fig. 146) can be run in at one end and out at the other. The manure should be spread out on the floor and allowed to be tramped on by the stock. Hogs may work it over without danger of losses.

Manure is often allowed to accumulate in box stalls or in covered feeding sheds. It is tramped on by the animals and kept

moist by the liquid excrement, sufficient bedding being used to absorb the excess and to keep the stock clean. This is good practice provided the manure is hauled out in time and not allowed to dry out and heat and decompose long after the animals have been turned out to pasture.

When manure is stored in the open, it should be placed in a pile having a flat top and nearly vertical sides. Never should the manure within the pile get so dry as to cause "fire-fanging" or burning. Piled as in Figure 147 it will heat.



FIG. 147.—Another farmer has forgotten that manure has a value.

Gardeners make use of compost heaps when they desire well-rotted manure. Often other materials are mixed with the manure when it is being piled, such as phosphate fertilizer, garbage, garden wastes, etc., to make the manure a better fertilizer to meet their needs. Hen manure can be better conserved and made a more adaptable fertilizer to general trucking and gardening purposes if twelve to fifteen pounds of acid phosphate, four to eight pounds of muriate of potash, and five to ten pounds of gypsum, or land-plaster, were added to every 100 pounds of the fresh manure.

Manure cisterns and very deep pits are sometimes used to store manure, especially the liquid. But because of the difficulty in getting the manure out, comparatively few farmers in the United States are using them.

Gypsum, or land-plaster, is often recommended as a conserva-

tive material to mix with manure; but the results have not been sufficient to encourage its use.<sup>9</sup>

Lime of any kind should not be mixed with manure when it is being stored, because it favors fermentation. It also liberates the ammonia.

**Good Practice to Mix Horse and Cow Manures.**—Horse manure is a warm, dry manure, and cow manure, cold and wet. The mixing of these two manures in a manure shed is advantageous, since the one will absorb the liquid of the other, and the resulting mixture is much more easily handled.

**Light Applications Better Than Heavy.**—It has been clearly shown that, in general farming, it is better to use medium to light applications of manure rather than heavy. In a thirty-five year test made at the Pennsylvania Station, a twenty-ton application per acre in a four-year rotation resulted in crop increases valued at only \$5.38 per acre more than when twelve tons were applied. The applications were made twice in the rotation or at intervals of two years, at the rate of ten and six tons per acre, respectively. Corn, oats, wheat and mixed clover and timothy were the crops grown.

Similar results were secured at the Ohio Station in a seventeen-year test in which eight-ton and sixteen-ton applications, made once in five years, were compared; and at the Indiana Experiment Station, where comparisons were made between 14.2-ton and 8-8-ton applications, extending through twenty-three years. These results show that when the supply of manure is limited, it is better to cover as much land as possible at the rate of six to eight tons per acre than to get over comparatively few acres with a heavy application (Fig. 148). Herein lies the great value of the manure spreader (Fig. 146). It is also well worth remembering that frequent light applications prove more profitable than heavy applications at long intervals.

**Plowing Under vs. Disking in Manure.**—The plowing under of manure is usually recommended, especially on the heavier soils, largely because of the loosening effect produced in addition to its fertilizing value. It is best to plow under coarse litter (in the

---

<sup>9</sup> In a 15-year test made at the Ohio Station in which forty pounds of gypsum were mixed with each ton of manure used, the average results showed a gain, above the cost of the gypsum, of eighteen cents in case of yard manure, and a loss of five cents per ton when it was mixed with stall manure. The gypsum cost six dollars per ton.

fall), and it is easier to incorporate manure in a heavy soil by plowing than by disking. Many tobacco growers have found it an excellent practice to disk in a light application of manure on crummy silt loams, in addition to the manure plowed under. On light soils best results are usually secured when fine manure is disked in.

**Concerning the Application of Manure to Clover Fields.**—It is often asked, "Is it not better to apply the manure as a top-dressing to the clover field rather than apply it for corn?" This

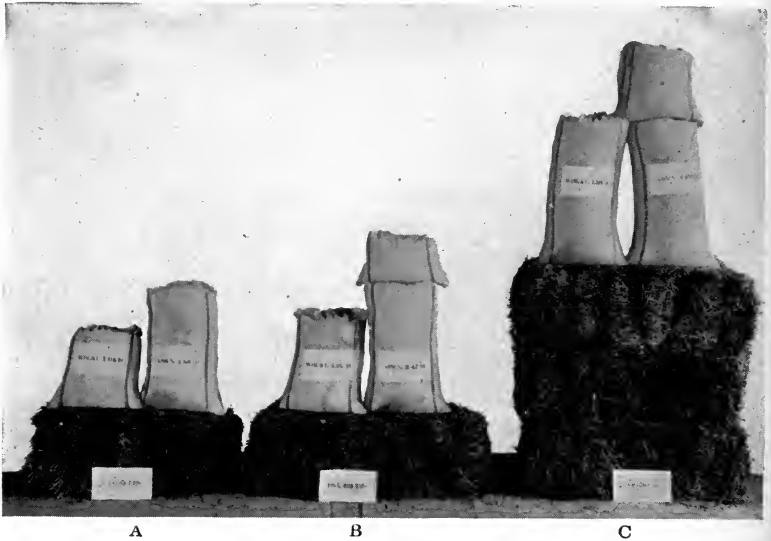

FIG. 148.—The returns from one ton of manure. Eight-year average. *A*, Produce from one ton yard manure; *B*, produce from one ton stall manure; *C*, produce from one ton stall manure reinforced with 40 pounds of rock phosphate. (Ohio Station.)

can best be determined definitely on any particular field or farm by trying out the two systems. Soil conditions may also determine the course to follow.

Since soil improvement depends largely on the growing of good clover, it seems best, when a soil is low in fertility, to apply the manure as a top-dressing on the clover. This favors growth and root development, so that more hay is secured for feeding, and a better sod is formed which greatly increases the organic matter of the soil when plowed under. A light application of manure on the better clover sod produced in this manner, enables the production of good corn or any other cultivated crop.

When the soil is in a good state of fertility, applying the manure for corn seems the better practice.

**Concerning Winter Application.**—The common opinion is that severe losses occur when manure is applied to land during winter. On steep hillsides there is danger of heavy losses, since heavy rains and melting snow wash many of the small particles of manure from the field. It is better, therefore, to apply manure to steep hillsides just prior to plowing.

On level or gently rolling land, losses are generally quite small; and, no doubt are much less than the losses which occur in the average barnyard when the manure is allowed to accumulate there.

**Residual Effect of Manure.**—The beneficial effect of manure on soils of the heavier types may be of long duration. The best known experiment is the one made at an Experiment Station in England (Rothamsted). For eight successive years manure was applied to a piece of land at the rate of fourteen tons to the acre. The land was then left in grass without manuring or fertilizing for fifty years. The yields of hay were compared with those on a similar field on which no fertilization was made. The average increases in yield for each decade, resulting from the previous applications of manure, were fifty-seven, twenty-four, six, fifteen and twenty-eight per cent, respectively.<sup>10</sup>

**Manure Not a Perfect Fertilizer.**—General results demonstrate conclusively that manure alone cannot maintain fertility nor can it be used exclusively in regenerating soils. The continued use of such manure on many dairy farms has led to an unbalanced condition in the soil. Oat crops especially, secure so much nitrogen that they lodge badly. Many dairy farmers who purchased "run-down" farms, and who sought to improve the soil through the use of manure, have found that phosphate fertilizers, in particular, are quite necessary to supplement the manure to give the results desired. On sands, the reinforcing of the manure with both phosphates and potash proves most profitable.

Of all the materials that may be used in reinforcing manure, there are none better than phosphate fertilizers. The Ohio Station has produced conclusive results on this point. The following table gives the average results of a fifteen-year test on silt loam soil with manure reinforced with phosphates made at that Station (Fig. 148).

---

<sup>10</sup> The Book of the Rothamsted Experiments, 1917, page 156

*Net Value of the Increases per Ton of Manure Reinforced with Phosphates*

Manure and treatment	Net value of increases per ton of manure* (Including 3 crops)
Yard manure (untreated) †.....	\$2.55
Stall manure (untreated).....	3.31
Yard manure +40 pounds rock phosphate per ton.....	3.54
Stall manure +40 pounds rock phosphate per ton.....	4.49
Yard manure +40 pounds acid phosphate per ton.....	4.10
Stall manure +40 pounds acid phosphate per ton.....	4.82

\* Eight tons of manure were applied to the acre once in a three-year rotation of corn, wheat and clover. The yard manure was taken from the open yard, where it had been exposed to the weather for 3 or 4 months during the winter. The stall manure was hauled from the stable directly to the field and spread at once in the early part of winter. The fertilizer was dusted over the manure-spreader loads.

† The cost of the fertilizer was deducted before computing the net values of increases per ton of manure.

Though farming with livestock is recognized as an excellent way to keep up the fertility, because of the opportunity of returning to the land much of the fertilizing elements,<sup>11</sup> yet it cannot be assumed that because a farmer has stock on his farm he need give no thought whatever to the future of his soil. Manure is often poorly cared for, causing enormous losses annually. It is evident that the farmer who understands the care, reinforcing and proper use of manure will secure far greater returns from his land, and be able to pass his farm on to others in a much better condition, than the man who farms it without livestock or who farms it without any definite plan for maintaining the fertility of the soil.

**Illustration Material for Lessons.**—Have on hand four-quart samples of the fertilizers important in your section. Include the four classes, also a few miscellaneous samples.

**Demonstrations.**—*Material Needed.*—Enough unproductive soil to fill 8 two-gallon jars; 16 quarts of a light sandy soil; about 3 pounds of green clover finely chopped, or its equivalent in dry clover chaff; 12 two-gallon jars; 3 one-quart Mason jars; some corn and oat seeds; 8 grams each of sodium nitrate, sodium acid phosphate and potassium sulfate; about 2 quarts of fresh horse dung; and a few strips of red litmus paper.

<sup>11</sup> It is commonly believed that when all crops are fed on the farm, and the manure is carefully cared for and hauled to the fields, soil fertility can be maintained indefinitely. This is impossible, because in the feeding transaction unavoidable losses of the fertilizing elements occur—particularly of phosphorus.



**To Demonstrate the Beneficial Effect of Active Organic Matter in Soils.—**

*Procedure.*—Mix with 16 quarts of a light, sandy soil an amount of green clover equivalent to 3 tons of clover hay per acre. Put the mixture into 2 two-gallon jars, and plant one to corn and the other to grain. Fill two other jars with the same soil, but without the green clover, and plant one to corn and the other to grain. Observe results.

*Questions.*—(a) Why are legumes generally the best green manuring crops?

(b) Mention ways in which organic matter improves soil fertility.

**To Demonstrate the Fertilizer Needs of an Unproductive Soil by a Pot Fertilizer Test.—***Procedure.*—Thoroughly mix a quantity (enough to fill 8 two-gallon jars) of an unproductive soil and fill 8 two-gallon jars. (Provide each jar with an opening at the bottom for drainage.) Number the jars and treat them as follows:

Jar No. 1—Give no treatment.

Jar No. 2—Add 3 grams sodium nitrate (N).

Jar No. 3—Add 3 grams sodium acid phosphate (P).

Jar No. 4—Add 3 grams potassium sulfate (K).

Jar No. 5—Add 3 grams each of sodium nitrate and sodium acid phosphate.

Jar No. 6—Add 3 grams each of sodium nitrate and potassium sulfate.

Jar No. 7—Add 3 grams each of sodium acid phosphate and potassium sulfate.

Jar No. 8—Add 2 grams each of the three fertilizing salts.

The fertilizing salts may be pulverized and mixed with the soil. Plant each jar to corn, place all in a favorable place, and observe results after about 4 or 5 weeks.

**To Show that Ammonia is Given off from Fermenting Manure.—***Procedure.*—Put some moist horse dung into a quart Mason jar and keep it covered in a warm place for about 2 days. Then hold a piece of moistened red litmus paper over the mouth of the jar. Note odor of the escaping gas, and note change in the color of the litmus paper. (Ammonia gas turns red litmus paper blue.)

**To Show How the Loss of Ammonia from Manure May be Reduced or Largely Prevented.—***Procedure.*—Fill a quart jar about two-thirds full of horse dung; wet with water, and tamp down well. Place in a warm place for about 2 days. Make similar tests as in the previous experiment.

**Laboratory Exercises.—***Material Needed.*—Four-quart samples of at least four of each class of commercial fertilizers; 3 tumblers; several strips of blue litmus paper; a saucer; a little sulfuric acid; 5 one-gallon jars; enough loam or silt loam to fill 5 one-gallon jars; a handful of corn; one-half cupful pulverized peat; 2 flasks or vinegar bottles; and a few ounces of ammonium carbonate.

**To Learn to Know the Common Commercial Fertilizers.—***Procedure.*—Study the samples of fertilizers provided, and record observations, etc., in tabular form as follows:

Class	Name of fertilizer	Availability of fertilizing constituent	Per cent fertilizing elements			Characteristics, odor, color, physical condition, etc.	Application per acre	Cost per ton
			N	P	K			

(Keep in mind local conditions).

*Questions.*—(a) Which of these fertilizers are true salts?

(b) Which of these fertilizers should be used with special caution when applied in the hill? Why?

(c) What is the difference between acid phosphate and rock phosphate?

(d) Which of the phosphate fertilizers is the most available?

(e) Is all the material composing acid phosphate soluble in water? (Try it.)

(f) How should rock phosphate be used for best results?

**To Continue the Study of Acid Phosphate.**—*Procedure.*—A. Place about a teaspoonful of acid phosphate in a dish and pour on about a tablespoonful of water. Mix thoroughly. Now dip a piece of blue litmus paper into the mixture. What does this indicate? (Soluble phosphate salts are acid in character.) Should lime be mixed with acid phosphate and applied as a mixture? (Consult text.) Why? Should acid phosphate and agricultural lime be applied to the same soil the same season? Explain.

B. Weigh out five grams (the weight of a nickel) of rock phosphate. Place it in a porcelain dish and add 5 grams of hot (130° F.) sulfuric acid. (Handle acid with great care.) Stir well with glass rod, and note changes.

*Questions.*—(a) How is acid phosphate usually made?

(b) How does the resulting material compare with the acid phosphate on the market?

(c) Tell briefly the steps in the manufacture of acid phosphate. (Consult any book on fertilizer manufacture.)

(d) Should a farmer attempt to make his own acid phosphate from rock phosphate?

**To Study the Effect of Applying Commercial Fertilizers on the Seed in the Hill.**—*Procedure.*—Fill 5 one-gallon jars with loam or silt loam and plant two hills of corn in each jar. Treat jars as follows:

Jar No. 1—No treatment.

Jar No. 2—Apply one-half an ounce of muriate of potash on the seed in one hill, and one-half an ounce of a mixed fertilizer on the seed in the other hill.

Jar No. 3—Same as Jar No. 2, only apply the fertilizer in the soil on the side of the hills.

Jar No. 4—Apply one ounce of rock phosphate on the seed in one hill and the same amount of mixed fertilizer in the other hill.

Jar No. 5—Apply muriate of potash broadcast at the rate of 200 pounds per acre. Mix the fertilizer well into the soil. Plant 4 kernels of corn. (One acre equals 43,560 sq. ft.)

Label jars properly, and place in the greenhouse. Water.

(Students may work in groups of five on this exercise.)

*Questions.*—(a) When corn is planted in hills 3 feet 8 inches each way, how much mixed fertilizer should be applied per hill when 100 pounds are applied per acre?

(b) What precaution should be observed in applying fertilizers in the hill or drill?

**To Determine Why Barnyard Water is Colored.**—*Procedure.*—Every farm boy has observed the peculiar color of barnyard water and has detected strong ammonia odors in the horse stable. The one condition is closely related to the other in this way: the nitrogen of an animal body is excreted through the urine. The principal nitrogenous substance in urine is urea. Urea is acted upon by fermenting organisms producing *ammonium carbonate* which,

with moisture, has the ability to *dissolve* organic matter. This accounts in a large degree for the brownish color of barnyard water.

We can observe this solvent action in the following experiment:

Place a good tablespoonful of organic matter (peat) provided in each of two flasks, and add 75 c.c. of ammonium carbonate solution to one and a like amount of water to the other. Shake each well for five minutes, then let stand for 20 minutes, after which time shake again for a few seconds. Run the liquid contents through filters into tumblers and note color of liquids. Explain results.

**Home Experiments and Projects.**—To determine the profitable use of acid phosphate on soil deficient in phosphorus.

*Procedure.*—Apply 300 pounds of acid phosphate on an acre of soil needing phosphate. Another acre beside this should be left unfertilized. Keep account of all costs, measure yields, and compute net profits. (One-tenth acre plots could be used as well.)

**Other Fertilizer Projects.**—To determine the effect of an application of mixed fertilizer applied on corn at the rate of 125 or 150 pounds per acre, in the hill, with a fertilizer attachment on the corn planter. A whole field of corn may be fertilized in this manner, but leave at least 4 or 6 rows through the field for a check. Determine increased yields at harvest time, and determine profits in the use of the fertilizer (Figs. 137 and 138).

Tests may be made determining:

- (a) The value of green manuring on sand or on any soil poor in organic matter.
- (b) The value of manure reinforced with acid phosphate.
- (c) The more economic use of manure when applied at the rate of 8 tons per acre over a 16-ton application. Keep account of all costs, determine yields, and compute net profits.

## QUESTIONS

1. Discuss the importance of available plant-food elements in relation to soil fertility.
2. What are the elements most considered in crop production?
3. What materials in a virgin soil contribute to the crop requirements of nitrogen, phosphorus and potassium? Is this supply inexhaustible?
4. What is the theory of fertilizers?
5. What are the substances commonly used to add needed elements to soils, or to render more available what is there?
6. Of what value is leaf-mold, grass, etc.?
7. What is meant by green-manuring? What are the benefits to be derived through this practice?
8. Does green-manuring ever prove profitable? Is it always necessary to apply green manure?
9. What are the best kinds of green manuring crops? Why?
10. Why is it important to maintain the organic matter in soils?
11. Name some crops used in green-manuring. Discuss their adaptability to different conditions.
12. What are some points to bear in mind in plowing under green crops?
13. What crops usually follow green-manuring? Why?
14. Discuss the importance of green-manuring in soil improvement.
15. What should determine whether or not a crop should be plowed under instead of being cut for hay? What is rowen?

16. In good soil management, is it necessary to sacrifice a crop (for green-manuring) to make soil improvement possible? Explain.
17. What are commercial fertilizers? How are the fertilizing elements in fertilizers commonly expressed?
18. Name the four classes of commercial fertilizers.
19. Name the common nitrogen fertilizers, and mention some facts about each.
20. Are farmers to rely on nitrogen fertilizers as the source of nitrogen? Discuss this point.
21. Name the common phosphate fertilizers. Tell of their phosphorus content, and availability.
22. In what three ways may the fertilizing constituent of phosphate fertilizers be expressed?
23. How is rock phosphate made? Discuss its use as a fertilizer.
24. What is basic slag? Tell of its use.
25. Compare ground steamed bone meal and acid phosphate as fertilizers
26. Distinguish between phosphorus, acid phosphate and phosphoric acid.
27. Discuss in general the necessity of fertilizing with phosphates.
28. In what special ways do phosphates affect crops?
29. A soil of low fertility was found to have lost one-half of its original phosphorus supply through exhaustive cropping. Is it absolutely necessary to add phosphates to raise the phosphorus content to the original amount before the soil can produce maximum yields? Explain. What kind of fertilizer should be used during the first few years of improvement? Later on what substitution may be made?
30. What phosphate is best to use for top-dressing? When does bone meal give best results? Basic slag? Rock phosphate?
31. Under what conditions do phosphates give best results on some soils?
32. Which seems the more profitable, rock phosphate or acid phosphate?
33. Name the common potash fertilizers, and give some facts about each
34. Distinguish between potassium and "potash."
35. Are potash fertilizers very generally used? What soils are particularly in need of potassium? Name some crops requiring large amounts of this element.
36. Discuss the use and value of wood ashes, muriate and sulfate of potash, and kainit.
37. What are mixed and complete fertilizers? In practice, how are these fertilizers designated?
38. What can be said of the use of mixed fertilizers?
39. Discuss the relation of commercial fertilizers to the maintenance of soil fertility.
40. What really determines whether or not a farmer should use, or continue to use, commercial fertilizers?
41. What are the factors determining the kind of fertilizer to use? Discuss and illustrate.
42. Compare high and low grade fertilizers as to meaning and value.
43. What is to be said concerning home mixing of fertilizers? What materials should never be mixed?
44. Discuss the ways in which fertilizers may be applied.
45. Are there ever any beneficial after-effects produced by commercial fertilizers? What makes this after-effect possible?

46. What is meant by manure? About what is the fertilizing value of a ton of average farm manure? Are all manures of equal fertilizing value? Illustrate.
47. Explain how feeding affects the value of manure.
48. Of what value is the liquid portion of manure?
49. What is the three-fold benefit derived through manure applications?
50. Why is manure such an excellent fertilizer?
51. Discuss the care of manure.
52. Which is more economical, light or heavy applications of manure? How has this been demonstrated?
53. Should manure be plowed under for best results?
54. When is it good practice to apply the manure to the clover field?
55. Is winter application of manure a good practice?
56. Tell of the residual effect of manure.
57. Can manure alone be used in regenerating soils, or to maintain fertility? Explain.
58. What is reinforced manure? What are some materials used for this purpose?
59. What is the best reinforcing material for manure? Give a good illustration.
60. For an outline summary of this chapter, see table of contents.

## PROBLEMS

1. A man applied muriate of potash (43 per cent K) to a peat soil at the rate of 100 pounds per acre and grew 8 tons of silage corn per acre. Can he maintain the potassium supply of that soil if he continues his method of fertilization for corn production?

2. A farmer applied a 3-12-4 fertilizer in the drill at the rate of 125 pounds to the acre, and thereby increased his corn crop 10 bushels per acre. Should he continue this practice?

3. "A" and "B" sell the same general grade of rock phosphate. A offers his for \$10 per ton with a guarantee of 13 per cent phosphorus. B sells his for \$12, guaranteeing a phosphoric acid content of 28 per cent. Who sells the cheaper fertilizer?

4. A land owner wishes to compound a fertilizer containing 5.25 per cent phosphorus and 10.5 per cent potassium for his marsh land. In what proportions should he mix acid phosphate (7 per cent P) and muriate of potash (42 per cent K)?

5. Compound a 2-8-3 fertilizer out of sodium nitrate (15 per cent N) acid phosphate (7 per cent P) and muriate of potash (42 per cent K).

6. A silt loam contains 0.04 per cent phosphorus. Its original content was 0.09 per cent. How much acid phosphate (7 per cent P) would be required to raise the phosphorus content of the soil to its original amount? How much rock phosphate (13 per cent P)? (See question 29.)

7. Determine the approximate, normal prices of the following fertilizers per ton: Sulfate of ammonia (20 per cent N), rock phosphate (30 per cent  $P_2O_5$ ), acid phosphate (16 per cent  $P_2O_5$ ), nitrate of soda (15 per cent N), kainit (14 per cent  $K_2O$ ), muriate of potash (52 per cent  $K_2O$ ), and sulfate of potash (50 per cent  $K_2O$ ).

8. At 15 cents a pound for nitrogen, 10 cents for phosphorus, and 8 cents for potassium, determine the fertilizing value of sheep manure. Of good hen manure.

9. A land owner grows corn averaging 65 bushels per acre, barley averaging 40 bushels per acre, oats yielding 50 bushels, red clover averaging 2 tons, and timothy yielding 2 tons per acre, in a 5-year rotation. He manures once in the rotation, for corn, at the rate of 15 tons of average manure per acre. Assuming no loss of fertilizing elements through leaching, can the farmer expect to maintain the fertility of his soil by continuing this practice? Would it be possible if it were a 3-year rotation with oats and timothy left out?

10. In a test, some horse manure containing 10.2 pounds of nitrogen, 1.84 pounds of phosphorus, and 8.8 pounds of potassium per ton, was left exposed to weathering for 6 months during the summer. During that time 36 per cent of the nitrogen, 50 per cent of the phosphorus and 60 per cent of potassium were lost. Suppose 50 tons were thus exposed, what would have been the total loss of each of the three fertilizing elements? Their total value at 15 cents, 10 cents and 8 cents per pound, respectively?

11. In the table, page 222, determine the per cent increase in net returns per ton of manure due to the use of phosphates as reinforcing materials.

## CHAPTER XIII

### SOIL ACIDITY AND LIMING IN RELATION TO FERTILITY

**Soil Acidity Explained.**—Many soils in humid regions are sour or acid in character, because they manifest certain chemical properties similar to acids. For example, an acid soil when sufficiently moistened with pure, distilled water, turns blue litmus paper<sup>1</sup> red just as vinegar does, or the juice of an orange. This condition is commonly spoken of as “soil acidity.”

**Soil Acidity Lowers Fertility.**—Soil acidity is harmful in several ways: (a) It causes a lack of available calcium (Ca) to meet the demands of crops like alfalfa and clover; (b) it renders the plant-food elements less available; (c) it favors the development of malnutrition diseases, especially of truck crops; (d) it causes soils to be less responsive to fertilizer and manure treatments, and (e) it favors the growth of certain weeds. It is important, therefore, that soil acidity be corrected to increase productiveness.

**Liming Defined.**—The only economic way to correct soil acidity is through liming. This means the application of neutralizing substances containing lime (CaO). In popular language “agricultural lime” is a general name given these substances, which may be either lime carbonates (CaO + carbon dioxide gas), lump or burnt lime (CaO), or hydrated lime (CaO + water). Whenever any such material is mixed in an acid soil, there begins at once a chemical reaction between the “lime” added and the soil, resulting in a disappearance of the acid conditions if a sufficient amount be applied.

**How Liming Improves Acid Soils.**—Liming may improve acid soils in several ways: (a) Available calcium is added; (b) acidity and certain poisonous substances are neutralized, thus creating an environment much more favorable to the growth and activity of the helpful soil bacteria, and to the growth of tender roots; (c) plant-food elements in soils are rendered more available; (d) greater returns are secured from fertilization; (e) the continued use of lime on acid clays and clay loams tends to improve their

---

<sup>1</sup> Blue litmus paper is paper saturated with blue litmus, and is commonly used as an indicator for acids. Litmus is a dyestuff extracted from certain lichens. It has the property of turning blue in an alkaline solution and red in an acid.

structure, and hence favors the development of good tilth; (f) weeds can be better controlled.

Calcium is to be regarded as an important plant-food element, particularly in growing alfalfa, clover, peas, etc. Alfalfa fails on an ordinary acid soil because it cannot secure sufficient calcium to meet its needs. Such crops as corn and grain, on the other hand, may grow quite well on acid soils, because there is still sufficient calcium in such soils to supply the needs of these crops (table on page 62; Figs. 149 and 156).

Any acids formed in soils through natural processes are neutralized by lime if it is present. In soils certain substances other than acids may be formed which may prove injurious if allowed to accumulate. Lime destroys the poisonous effect of many of these substances. The helpful soil organisms especially are injured when soils become acid. Most of them favor soils that are sufficiently supplied with lime. This explains why it is best to lime an acid soil before it is inoculated, particularly for alfalfa.

It has been shown that plant-food elements are more available in non-acid than in acid soils. This is especially true in the case of phosphorus. Often in a field of uniform silt loam, for example, crops suffer for want of phosphorus on acid areas, while on the areas not acid a phosphorus deficiency is not manifested—even though the acid soil contains more total phosphorus than the non-acid areas. Acid soils are generally in need of phosphate fertilizers.

It is wise economy to lime an acid soil if for no other reason than to enable the soil to give greater returns from manure and fertilizers. Some interesting results from the Ohio Station are presented in the following table. These are the results of an experiment extending through twelve years in a five-year rotation of corn, oats, wheat, clover and timothy, on an acid, long-cropped soil. This experiment is being continued.

These results, and many others, plainly show that liming is the first step in the improvement of an acid soil.

When crops like alfalfa and clover fail, or are poor and thin because of soil acidity, weeds have a better chance to grow, owing to the fact that they meet with little or no competition. On the other hand, when alfalfa and clover grow thick and strong under favorable conditions as regards lime, etc., the weeds are smothered. Sheep sorrel, or field sorrel, thrives especially well on acid fields in which clover or alfalfa fails.



*Effect of Liming an Acid Soil*

Treatment (once in 5 years)	Average value of crops per acre per rotation†		Average cost of lime and fertilizer per acre per rotation		Net gain per acre per rotation	
	Unlimed	Limed	Unlimed	Limed	Unlimed	Limed
No manure, no fertilizer..	\$49.40	\$61.40	\$.....	\$ 5.00‡	\$.....	\$ 7.00
Manure (8 tons per acre).	78.58	94.49	16.00	21.00	14.96§	25.87
Acid phosphate (320 lbs. per A.).....	67.80	81.80	2.60	7.60	15.20	24.20
Complete fertilizer*.....	87.76	104.49	17.60	22.60	23.46	35.09

\* Application per acre consisted of a mixture of 240 pounds nitrate of soda, 480 pounds acid phosphate and 240 pounds muriate of potash.

† Corn was rated at 40 cents per bushel, oats at 30 cents, wheat at 80 cents, corn stover at \$3.00 per ton, straw at \$2.00 and hay at \$8.00.

‡ The equivalent of 4 tons of carbonate of lime (pulverized limestone) was applied to the acre in the 12 years. Average cost, \$3.00 a ton laid on the land.

§ Increases were calculated not on the average of all the unfertilized plots, but on the average of two unfertilized plots, one on either side of a treated plot.

**Liming Beneficial in Conjunction with Green Manuring.**—

An acid soil is unfavorable to the decomposition of green-manuring crops and to nitrification. Moreover, during the decomposition of green crops plowed under, acids are formed, causing a temporary increase in the degree of acidity. For most crops the presence of lime to neutralize these acids as soon as they form proves beneficial. At the Virginia Truck Station best results were secured with peas and beans when lime was used in conjunction with cow-peas plowed under green or dry in the fall. For best results it is desirable, therefore, to lime an acid soil before planting a green-manuring crop, or in some cases, to lime just after the crop is turned under.

**When Liming is Most Profitable.**—Liming is most profitable when growing alfalfa. It is common to obtain increases from 100 to 600 per cent in the growth of alfalfa by liming acid soils, or to secure a successful producing stand over absolute failure (Fig. 149). Seventy per cent of the alfalfa failures studied in Wisconsin in the period from 1912 to 1917 were due to acid soils. Liming acid soils for alfalfa, particularly, may be the means of saving much expense in hay production, since it is more economical to produce twenty-five tons of alfalfa from five acres properly prepared than from fifteen acres in need of lime.

Just liming alone has proved about as beneficial as manuring in growing corn on some very acid, black, sandy soils.<sup>2</sup>

<sup>2</sup> These soils are so strongly acid, farmers consider them barren.

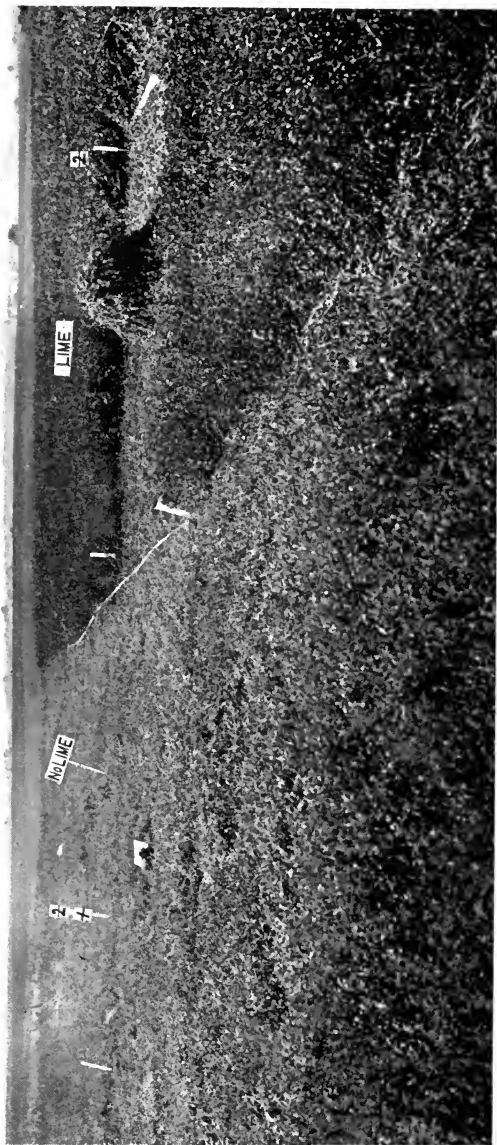

FIG. 149.—No lime; no alfalfa. The whole field was inoculated. This soil needs lime for alfalfa even though limestone is present in the subsoil at a depth of three feet. (Wisconsin Station.)

Liming, and also inoculation, may prove very profitable in growing peas<sup>3</sup> (Fig. 122).

**Other Crops Benefited by Liming.**—Aside from alfalfa, medium red, Japan, and mammoth clovers, and peas, the following field crops are directly benefited by liming when grown on acid soils: Cabbage, sugar beets, tobacco, and to a lesser extent, soybeans, barley, peanuts, hemp, muskmelons, and rape. The following garden crops grow best on soils sufficiently supplied with lime: Asparagus, common beets, celery, lettuce, onions, parsnips, peppers, salsify, spinnach, and to a lesser extent, the eggplant.

**Crops Which Tolerate Acidity.**—There are many crops that grow well on slightly or medium acid soils—lupines,<sup>4</sup> cowpeas, velvet beans, vetch, corn, potatoes, sweet potatoes, oats, wheat, cotton, rye, buckwheat, alsike, crimson and bur clovers, beans, millet, red top, watermelon, blackberry, raspberry and strawberry.

Alsike clover, soybeans, velvet beans, crimson clover and bur clover are well adapted to acid soils, though they grow best on limed soils, especially if strongly acid.

Certain citrus fruits, such as grape-fruit, are harmed by liming. Other crops, like pineapple, have been injured by an excess of lime on sandy soils.

In some cases, liming favors the development of certain crop diseases, such as scab in potatoes; and in other instances it is the best remedy—club-root in cabbage and nematodes on root crops, for example.

The fact that there are many crops that can tolerate soil acidity does not mean that they are not benefited in any way by liming. Most of these crops respond to liming because of its general renovating effect. When clover, for example, is benefited through the use of agricultural lime and a prime sod is produced, the crops following must necessarily be increased because of the better clover and improved soil conditions. It is fortunate, nevertheless, that there are so many good crops that can tolerate slight to medium degrees of soil acidity, since soil acidity is so prevalent in humid regions.

**How to Tell Acid Soils.**—Acid soils may be determined in different ways, as follows:

---

<sup>3</sup> A 3-year test at Columbus, Wisconsin, gave an average increase of 32.4 per cent due to liming alone. Field had been inoculated. Soil, silt loam.

<sup>4</sup> Lupines generally do not respond to liming, but are frequently injured, instead. Cowpeas seem to grow well without liming.

(a) **By the Use of Blue Litmus Paper.**—This method consists in allowing well-moistened soil to come in contact with blue litmus paper, which can be secured of any good druggist. When the soil is moist from rain or on thawing, make a slit in it with a clean knife blade and insert one end of a piece of blue litmus paper, then press the soil over it and allow it to stand for fully three minutes. If the paper becomes pink in spots or over the whole end, the soil is acid.

This test may also be made by placing the litmus paper in between two halves of a ball of wet soil; and, also, if the soil is dry, by placing a small amount of soil in a clean dish and moistening it with boiled, soft water to a stiff mud. By means of a clean stick, the litmus paper is placed between two portions of the wet soil.

Another way is to place a strip of blue litmus paper on a piece of clean window glass, make a mud ball, break it into halves, place one of the halves flat side down over the paper on the glass, press the soil down firmly, and allow it to stand for five minutes.

*Precautions.*—Do not mistake a fading of the blue color of the paper as an acid reaction; the change of color should be from blue or light blue to pink or pink-red. Keep the litmus paper, when not testing, in the dark and in a clean bottle or box. Do not allow the portion of the litmus paper which is to be placed in the soil to come in contact with perspired fingers or hands. Perspiration is acid in character. Use water that has been previously boiled.

The litmus paper test is simple and reliable for field use, but it cannot determine the “degree” of acidity very accurately.

(b) **By Chemical Tests.**—Several chemical tests may be used, not only to detect an acid condition, but also to determine the degree of acidity and the amount of lime necessary to correct this condition.<sup>5</sup>

(c) **By Alfalfa and Clover Failures.**—Since alfalfa and medium red and mammoth clovers are more or less “sensitive” to acidity, the failure of these crops usually indicates acid soils (Fig. 149).

(d) **By the Growth of Certain Plants.**—Peat beds on which blueberry, huckleberry and cranberry grow are acid. Uplands on which blueberries grow are also acid. Clover and alfalfa fields

---

<sup>5</sup> The Truog Soil Acidity Test devised at the Wisconsin Station may be mentioned as a simple and accurate test for determining the degree of acidity in soils, and the amount of agricultural lime to use in specific cases. Simple apparatus for making this test may be purchased of school supply houses.

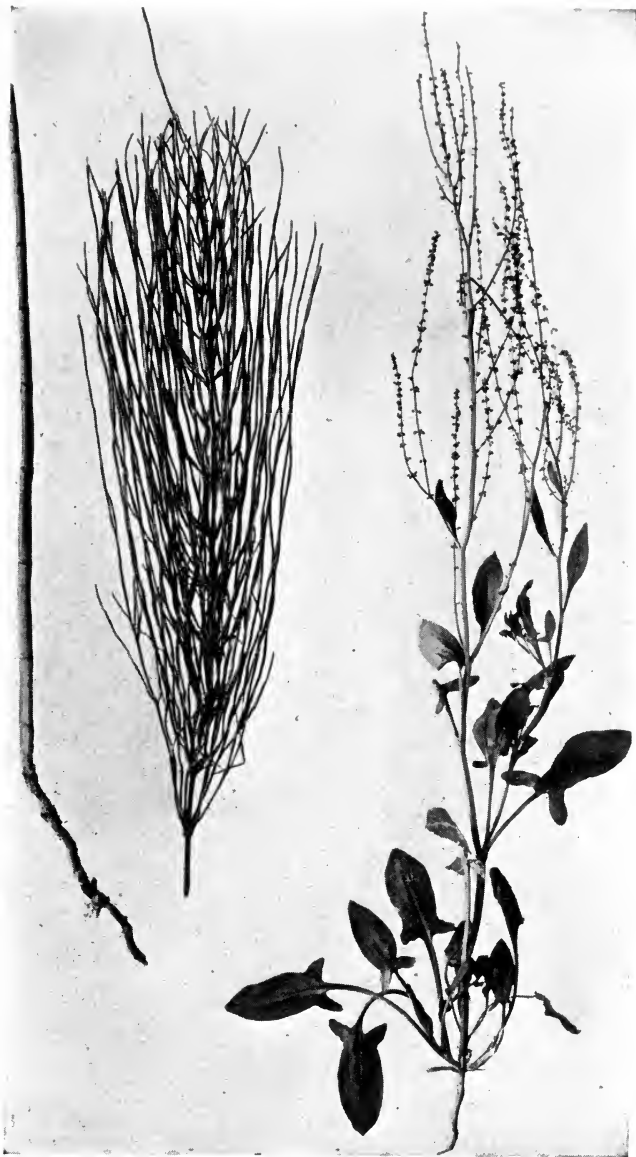

FIG. 150.—Two weeds that thrive on acid soils when clover or alfalfa fails. To left, horse-tail rush; to right, sheep sorrel, or horse sorrel. (Wisconsin Station.)

infested with sheep sorrel, horsetail rush (Fig. 150), common plantain, paintbrush, corn spurry and wood horsetail are usually acid. The fields become infested with such weeds because the soil conditions are unfavorable to the clover or alfalfa.

Conversely, soils on which alfalfa, sweet clover and the June-berry grow are usually not acid. Marsh lands, or other low soils, which become thinly coated with a white substance invariably are not acid (Fig. 151). This white substance in humid climates is usually mild alkali.

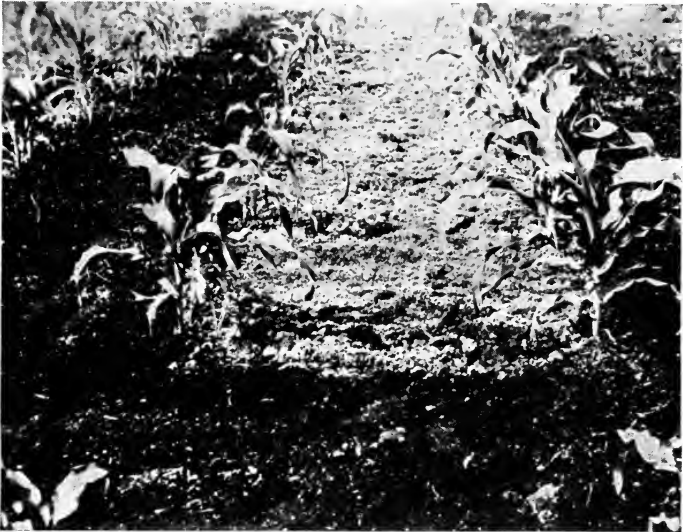

FIG. 151.—This marsh soil is not acid because it becomes coated with a thin, white coating of mild alkali.

**Low Wet Lands Not Necessarily Acid.**—It is commonly believed that all low, wet soils are sour. In a general sense, there is no relation, whatever, between wet lands and acidity. In sections in which both acid and non-acid soils occur, the low soils are the least acid or not sour at all; either because of seepage which brings carbonate of lime and other substances to the surface, or because carbonate of lime is washed down from the surrounding uplands, as in a limestone country.

Acidity is rarely found in soils or valleys which are frequently flooded by streams coming from limestone regions.

Peat and muck soils surrounded by high, limestone soils are

generally not acid, or only slightly so; whereas those in sections where limestone is absent are generally strongly acid.

**How Soils Become Acid.**—Soils become acid when they lose carbonate of lime and other substances of a similar chemical nature. In mineral soils, deficiency of carbonate of lime is brought about by leaching and cropping. Leaching is the greater factor. Certain determinations have shown that on ordinary cropped fields the total amount of lime removed annually by leaching is equivalent to 300 to 500 pounds of carbonate of lime per acre to a depth of four feet. From uncropped, cultivated fields the losses may double these amounts.



FIG. 152.—Soil acidity is increased by dust from zinc-ore roasters. Vegetation in background destroyed by sulfur fumes. (Wisconsin.)

In undrained peat and muck soils, acidity develops through the accumulation of acids resulting from the decomposition of the organic matter; and in drained and cropped peats, deficiency of lime may be brought about in the same manner as in mineral soils.

**Acid Soils Are Extensive.**—The great majority of soils of the East, South and portions of the Middle West are in immediate need of liming, not to mention extensive areas elsewhere. Three-fourths and more of the soils of New York, Wisconsin and Indiana are acid; most of the soils of Massachusetts have not sufficient lime for highest productivity; the soils of the greater portion of Tennessee are acid; large areas of Missouri and Oregon are in need of liming; the same may be said of Georgia, Mississippi and other states.

**The Nature of Soil Acidity.**—In practically all upland, acid mineral soils, the acid characteristics are imparted to them mainly by insoluble acid substances which in themselves are soil particles. In such soils, therefore, reduction of acidity through leaching is impossible.

In some cases, upland soils may be acid because of the accumulation of certain organic or mineral acids (Figs. 152 and 153).

In undrained, cumulose soils, acidity is due, in a large measure, to the presence of soluble organic acids which may be largely leached out when the marsh is thoroughly drained. On low sand islands in undrained acid marshes, the soils are usually strongly acid because they are saturated with the organic acids from the surrounding peat. When the marshes are drained these sand islands become less acid. Permanent acidity in peat must necessarily result from the presence of insoluble, acid organic substances. Loss of lime increases the acidity of drained, acid peats.

**Kinds of Agricultural Lime.**—Many materials are suitable for liming soils, such as:

- |  |   |  |
|--|---|--|
| A. Carbonates of lime ( $\text{CaO} + \text{CO}_2$ ) | } | <ul style="list-style-type: none"> <li>a.—Pulverized limestone.</li> <li>b.—Air-slaked lime.</li> <li>c.—Marl.</li> <li>d.—Waste lime.</li> <li>e.—Pulverized shells.</li> <li>f.—Marble dust.</li> <li>g.—Pulverized coral.</li> <li>h.—Chalk.</li> </ul> |
| B. Lump or burnt lime ( $\text{CaO}$ ).              |   |  |
| C. Hydrated lime ( $\text{CaO} + \text{water}$ )     |   |  |

**Pulverized Limestone.**—Strictly speaking, limestone is calcium carbonate (Fig. 154). When a rock consists of a combination of calcium and magnesium carbonates it is called magnesian limestone or dolomite. The name "limestone" is commonly applied to both rocks. Limestone may be distinguished from other rocks by the fact that it gives off bubbles of gas when treated with dilute acid (muriatic acid). This is a common test for any carbonate.

Limestone is prepared for direct agricultural use by crushing and pulverizing (Fig. 155). When it is pulverized so that about fifty to sixty per cent of the material will pass through a sixty-mesh sieve<sup>6</sup> it may be considered of standard fineness (Fig. 156). The fine material produces immediate action in soils, while the

<sup>6</sup> A 60-mesh sieve means a sieve having perforations  $\frac{1}{60}$  of an inch in diameter.





FIG. 153.—Soil acidity caused by mineral acid. Sulfide sludge washed over bottom-land. Weathering of sludge destroyed vegetation. (Wisconsin.)



FIG. 154.—A limestone quarry. A source of agricultural lime.

coarse particles give to the soil a reserve of lime carbonate. The best grades of limestone contain from 90 to 100 per cent carbonates.

In sections far from railroads and from limestone-pulverizing plants, and in which outcrops of good limestone occur, farmers may find it much more economical to pulverize their own limestone by using small pulverizing machines (Fig. 157). Limestone is often found on farms where the fields are acid (Figs. 158 and 159).

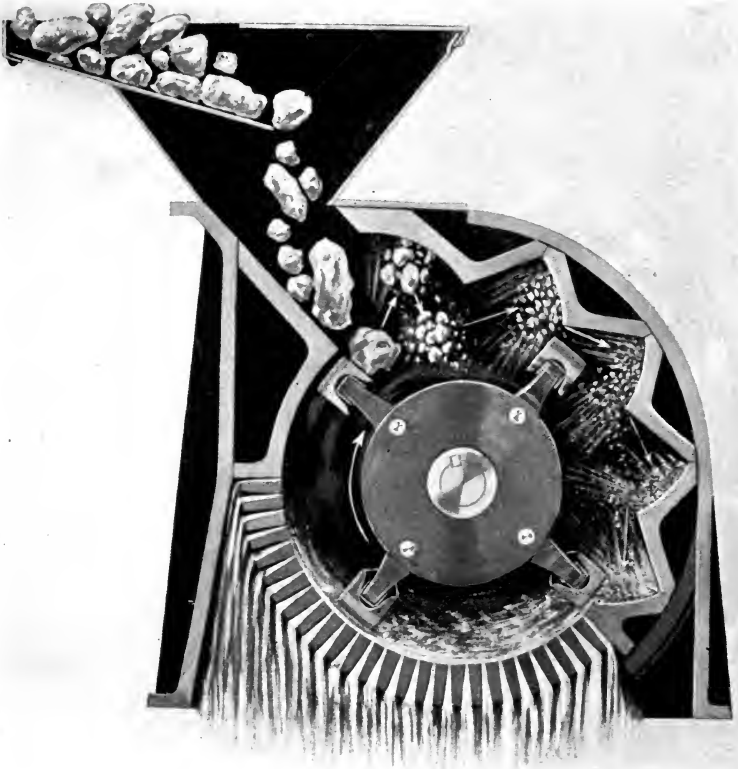

FIG. 155.—Limestone pulverizers are built on the swing-hammer principle.

Limestone screenings from crushed rock are frequently used for liming. Sometimes this material is as fine as pulverized limestone, but more often it is rather coarse, and hence slow acting.

Magnesian limestone in general is equally as good as pure limestone for liming.

Pulverized limestone is considered best to use on sandy soils.



FIG. 156.—Limestone converted into soil improvement material. This soil is acid even though it is underlaid by limestone.



FIG. 157.—This farmer is pulverizing his own limestone for soil improvement.



FIG. 158.—This farmer found a good outcrop of excellent limestone. Most of his soils are strongly acid.



FIG. 159.—A soil derived from limestone and underlaid by crumbled limestone. This soil is acid to a depth of three and one-half feet, within two inches of the rotten limestone.

**Air-slaked Lime.**—This is formed when lime used in making plaster and mortar is exposed to the air. On exposure, the carbon dioxide gas of the air is absorbed and this action converts the lime

into lime carbonate again. Air-slaked lime is usually finely divided and can be applied directly to the land.

**Marl** is a name given to earthy deposits, usually more or less friable in character and containing varying amounts of carbonate of lime. Marl beds are usually found in marshes. If a farmer has a deposit of good marl and his soils are acid, he can utilize such a deposit as a source of agricultural lime. Marl should be allowed to air-dry before using (Fig. 8).

Pulverized kiln-dried marl may be purchased for liming in some sections.

In New Jersey, the term "marl" is applied to Greensand material which contains some potassium. Deposits of shells partially disintegrated and more or less cemented together are found in some localities. Such deposits are commonly called "shell marl."

**Waste lime** is a by-product from industries, such as lime-kilns, gas works, paper mills, beet sugar factories, tanneries and water-softening processes. Some of this material may contain substances that might be injurious to plant growth; and sometimes it is very wet, making its application difficult and transportation unprofitable.

**Pulverized Shells and Coral.**—Oyster shells, clam shells, and coral, when cleaned of dirt and organic matter, contain from ninety to ninety-five per cent carbonate of lime. When pulverized these make excellent materials for liming. Shell dust may be secured in some places as a waste product from button and chicken grit factories.

**Marble Dust.**—In the East, limited amounts of marble dust as waste from marble works are available. This is high-grade liming material.

**Natural chalk** is carbonate of lime that has been deposited in much the same way that marl has been. Chalk has been used to a considerable extent in European countries. In this country such deposits are of insufficient extent to be considered a source of agricultural lime.

**Lump or Burnt Lime.**—This is quick or caustic lime—the most concentrated form of lime that may be used. It is produced by heating limestone to a red heat in kilns, thus driving out the carbon dioxide gas and leaving the common lump lime. This form of lime can be procured in every town. When used in proper amounts little or no injury can come from its use, especially on

the heavier soils. It should be finely ground, water-slaked or air-slaked before applying. When lump lime is finely ground the term "ground lime" is given it.

Lump lime for agricultural use is more generally used in the Eastern States than in the Middle West.

**Hydrated Lime.**—When lump lime is treated with water or steam, in the absence of air it becomes a powder quite like ground lime in appearance, if the proper amount of water or steam is used. The names "hydrated lime," "limoid" and "limate" are given this product by manufacturers. It is finely divided and ranks next to lump lime in concentration. This material is not commonly purchased for liming.

**Land-plaster Cannot Correct Acidity.**—Land-plaster, or gypsum, is sulfate of lime, a material quite different from carbonate of lime. Under certain conditions it supplies calcium and sulfur as plant-food elements, but when pure it has no value in correcting acidity. Usually common land-plaster contains a trace of carbonates as impurities, but not enough to give it any value as a neutralizer.

**Comparative Value of Agricultural Limes.**—The neutralizing value of any material used in liming depends upon its content of lime (CaO) or the equivalent in carbonates, and on its fineness. Pure limestone, for example, contains fifty-six per cent lime (CaO), or it is 100 per cent lime carbonate—forty-four per cent being carbon dioxide gas (CO<sub>2</sub>). It is the calcium and magnesium or their oxides (CaO and MgO) which produce the beneficial effect in acid soils; and the finer the material, the quicker the action. Accordingly, the comparative value of the different forms of lime may be stated as follows:

(a) On the basis of lime content—one ton of lump lime equals 1.3 tons of hydrated lime equals 1.8 tons of carbonate of lime.

(b) On the basis of neutralizing value when dry and of equal fineness—one ton of lump lime equals 1.3 tons of hydrated lime equals 1.8 tons of carbonate of lime.

(c) On the basis of quickness of action, considering pulverized limestone as it is commonly used—one ton of lump lime finely divided is equal to about three tons or more of pulverized limestone.

Finely pulverized limestone is much more effective than coarsely crushed limestone.

**Best Material for Liming.**—For first application to benefit special crops like alfalfa, it is desirable to use finely divided

material. Coarse material may be used for subsequent applications. For quick results, lump lime, hydrated lime or finely divided air-slaked lime may be used. Pulverized limestone, marl, ground shells, or marble dust is usually preferred on sandy soils. Lump and air-slaked lime may also be used, but never in excessive amounts. On acid peats and mucks, lump lime, hydrated lime and fine air-slaked lime are good.

Ordinarily, the best agricultural lime to use is that material which is finely divided and which contains the most lime, or carbonate equivalent, in a dollar's purchase (all cost and labor to get it applied to be considered). It is important, therefore, to know the moisture and lime, or carbonate, content of any material before buying. Whenever agricultural lime is secured through transportation, it is cheapest to purchase it in carload lots.

**Amounts of Lime to Apply.**—The following rates of application to the acre may serve as guides in liming:

On light soils (per acre)	{	Of slight acidity	{ One ton pulverized limestone, marl or shell dust (preferred) 500 to 1000 pounds lump lime or 1 ton air-slaked lime
		Of strong acidity	{ Two to 4 tons pulverized limestone, marl or shell dust (preferred) One to 1½ tons lump lime, or from 2 to 3 tons air-slaked lime
On the heavier soils (per acre)	{	Of slight acidity	{ One to 1½ tons pulverized limestone, or any other good grade of carbonate One-half to three-fourths ton lump or hydrated lime
		Of strong acidity	{ Two to 4 tons pulverized limestone, or other carbonate. (Heavy applications for crops like alfalfa, clover and peas) One and one-half to 2 tons lump lime. (Especially good for clay loams and clays)

The coarser or more wet the material, the heavier should be the application.

Poor acid soils are in greater need of lime than rich acid soils.

**When and How to Apply Lime.**—In liming it is well to remember that the place for lime is *in* the soil and not on top of it; and the more thoroughly it is mixed with the soil, the better the results. Commonly, the full effect does not show until two to four years after the lime application is made. Any rational method whereby lime may become thoroughly incorporated in the soil is recommended (Fig. 160).

Liming should be done previous to planting the crop to receive the direct benefit. To be most effective, lime should be applied to plowed land and thoroughly mixed in by harrowing or disking. Application may be made at any convenient time. It is good practice, when alfalfa and clover is to follow corn, to apply the lime when the ground is fitted for corn, particularly if a carbonate form is used. In so doing the acidity is much reduced before the alfalfa or clover is sown. In such cases pulverized limestone may be conveniently applied by spreading it over the spreader-loads of manure.



FIG. 160.—Applying lime with a lime spreader.

Lime is most conveniently applied through the use of lime spreaders (Fig. 160). When only a few acres are to be limed at a time, the material may be spread by hand directly from the wagon if it is damp enough to prevent excessive blowing; otherwise it is best to place the material in small piles, then spread it over the ground by means of shovels.

Lump lime is best applied by placing it in small piles about two rods apart each way on plowed ground. If a ton, for example, is to be applied to the acre, fifty pounds should be placed in each pile. When the lime becomes slaked, it is spread and disked. It is usually best to shovel the pile over at least once to facilitate slaking.

Dry air-slaked lime, quicklime, hydrated lime and kiln-dried



marl are disagreeable to handle because of the dust inhaled. Wearing a moist sponge over the nose is a good precaution.

**Applying Lime As a Top-Dressing.**—The application of finely pulverized limestone, marl and thoroughly air-slaked lime as a top-dressing on sandy soils for young clover or alfalfa may prove quite beneficial, though best results may be obtained by liming the plowed field sufficiently before seeding. The openness of a sandy soil enables the fine lime particles to be carried down more or less into the soil. Top-dressings on heavy silt and clay loams have not given satisfactory results, for these soils do not permit the entrance of lime particles as do sandy soils.

Sometimes a farmer wishes to lime his spring's seeding of clover on open silt loam, for example. In such a case, partially air-slaked or hydrated lime, finely divided, applied at the rate of a ton and a half or two tons to the acre early the following spring before the frost is out may prove beneficial. Such an application should not be made after the young plants have started their new year's growth, because sufficient caustic lime may be present in the material to injure them.

The application of lime as a top-dressing for pasture and permanent hay lands rarely proves profitable. The lime, exposed to rain as it lies on the firm surface, loses its fine physical state, and is taken but slowly into the body of the soil.

**How Often to Lime.**—The effect of even a moderate application of lime on an acid soil lasts a number of years. Leaching experiments have shown that the lime added to an acid soil does not leach out so rapidly as is commonly believed. Some experiments and field tests have shown that when agricultural lime is mixed into the top six inches of an ordinary acid soil, it passes downward very slowly.

On some fields which were limed more than ten years ago, the effect of the lime seems to be just as apparent now as then. When an acid soil is given an application of lime sufficient to neutralize all the acidity in the surface six or eight inches, subsequent liming may not be necessary for many years. The need of more lime can easily be determined by testing the soil for acidity.

**Cropping Conserves Lime.**—On an acid silt loam at the Cornell Station, New York, an application of burnt lime, at the rate of 3000 pounds per acre, did not increase the amount of lime found in the drainage waters from that soil.<sup>7</sup> These leaching experiments

<sup>7</sup> Cornell Sta. Memoir 12, 1918. The soil was acid in the first 3 feet and not acid at the fourth foot in depth.

show an average annual loss of about 433 pounds of carbonate of lime per acre to a depth of four feet when the land is cropped, and a loss of 918 pounds per acre when the land is left bare without any vegetation. The equivalent of thirty-three pounds of carbonate of lime was removed by the crops. Thus the equivalent of 452 pounds of carbonate of lime was conserved by cropping the land. These experiments show that cropping conserves the lime in the soil as compared with the same soil left bare, and that the annual loss of carbonate of lime per acre to a depth of one foot is probably not much more than about 108 pounds when the land is cropped.<sup>8</sup>

**Deep Plowing Cannot Be Substituted for Liming.**—It is sometimes reasoned that the lime which leaches out of the soil is caught and held in the subsoil, and that if the land is plowed deeply, this lime can again be brought to the surface. When soils are medium to strongly acid, this is impossible, since to a depth of a foot or more the subsoil is just as acid as, or more acid than, the first six or eight inches of surface soil.<sup>9</sup>

**Residual Soils from Limestone Become Acid.**—It is usually difficult for farmers in certain sections in which are found soils derived from and underlaid by limestone to understand how it is possible for them to become acid. Frequently in such cases the carbonate of lime has been so thoroughly leached out of them that the subsoils to depths of fifty inches or more, or to within two or three inches of the rotten, underlying limestone, possess extremely high degrees of acidity (Fig. 159).

**The Surface Soil the Critical Zone.**—It is a common belief that soil acidity has a direct injurious action on the roots of plants. Alfalfa, if any, would be most affected, since it so often fails because of acidity. On the contrary, no such injury has ever been found in ordinary acid soils.<sup>10</sup> Again, it is often thought

---

<sup>8</sup> Illinois Station concludes that the equivalent of 540 to 760 pounds of carbonate of lime is leached from the surface 21 inches of soil annually. Ill. Bul. 212, 1919.

<sup>9</sup> Based on the Truog test for acidity. Author's conclusions based on the tests of more than 300 samples of soil collected in 6-inch zones from more than 50 widely scattered fields.

<sup>10</sup> Hundreds of alfalfa roots extending into deep, strongly acid subsoils have been examined by the author on widely scattered fields. Recent investigations at the Wisconsin Station show that the acidity of the plant sap is sometimes higher than that of most acid soils. The acidity within the root, therefore, is often greater than that outside in the surrounding soil.

that it is unnecessary to lime an acid soil underlaid by limestone, because the plant roots would quickly penetrate deep enough to feed on the carbonate of lime. Numerous experiments show clearly that when an acid soil is limed and the material thoroughly incorporated in the surface five to eight inches, alfalfa can be grown most successfully; and if not limed, failure results, regardless of the facts that the acid soil may be underlaid at depths of two feet or more by partially decomposed limestone, and thorough inoculation made (Fig. 149).

**Alfalfa Can Grow Well on Rich Acid Soils.**—In some sections it is not rare to see most excellent crops of alfalfa growing on quite acid soils without liming and inoculation. These are either tobacco fields which have been heavily manured annually for several years, or rich and well-drained new lands. In either case the alfalfa feeds on the soil as corn does, for example—being able to secure its requirements without liming and without the aid of nitrogen-fixing, nodule organisms. In some of these fields the alfalfa roots were fairly well supplied with nodules, though not nearly so well as compared with alfalfa growing in normal non-acid soils.

Usually, however, it is profitable to lime even these soils as well as those only slightly acid when growing alfalfa. It has also been found that the richer the soil the higher the degree of acidity alfalfa can tolerate.

**Not Necessary to Neutralize All Acidity at Once.**—Some soils are so strongly acid that it would be prohibitive to apply sufficient lime to neutralize at once all the acidity in the surface six or eight inches. For most general farm crops it is not necessary. In such cases, a three-ton or four-ton initial application of pulverized limestone, for example, may be sufficient to give desirable results (Fig. 149).

**Use and Misuse of Lime.**—The use of lime in agriculture is perhaps one of the most striking illustrations of the tendency on the part of the farmer to seek some panacea, or cure-all, for soil ailments. Its use in farming dates back to 1100 B.C., and earlier. History shows that in some places liming has been encouraged and again discouraged, doubtless because of its misuse. The two following quotations are good illustrations:

“Now that this lime [meaning lump or quicklime] is of excellent use, and wonderful profit, do but behold almost all the Countries of the Kingdom where there is any barrenness, and you

shall find and see how frequently Lime is used, in so much that of mine own knowledge in some Countries where (in times past) there was one Bushel made or used, there is now many loads, and all risen from the profitable experience which men have found in the same." (Published in London, Eng., 1660.)

"We must guard against its [referring to lump or quicklime] abuse, for it has been abused terribly in times past, so much so as to give rise to two dictums—inexact it is true: 'Lime enriches the father and impoverishes the son'; and again, 'Lime once and make a fortune. Lime twice and lose it.' In either case the blame ought not to be put on the lime, but on the person who has abused it. It would be better to say, 'When lime has impoverished the soil it is because the farmer does not know how to use it.'" (Published in London, Eng., 1916.)

Too much should not be expected of agricultural lime. It contains no nitrogen, phosphorus or potassium,<sup>11</sup> and hence it cannot supply any of these elements. It alone can never maintain fertility or restore a depleted soil to its original productivity. An eminent liming authority<sup>12</sup> in this country has written the following:

"Lime will not take the place of fertilizer or manure; on the contrary, lime will only produce its full effect on land that has been previously well fertilized or manured."

**Fertility Regulated Through Liming.**—The benefits to be derived through liming are so fundamentally important that sufficient lime in the soil may be regarded as a fertility regulator. Its proper use in increasing crop production and in maintaining fertility presupposes the presence of a good supply of nitrogen, phosphorus and potassium. Just lime alone, therefore, is not the only material to add to a depleted soil to grow good clover or alfalfa, or to regenerate that soil. Liming is a necessary first step towards improvement, to be supplemented or followed by the use of phosphate fertilizers, manure, green manure and, on some soils, a general use of fertilizers including potassium. Lime, acid phosphate, and manure may be added the same season. It is best, however, to mix the lime thoroughly into the soil before applying any soluble phosphates. An old slogan said: "Lime and lime without manure makes both farm and farmer poor."

---

<sup>11</sup> Waste lime from beet-sugar factories contains small amounts of these elements.

<sup>12</sup> Director Thorne of the Ohio Station.

Whenever liming alone increases general crop production, fertilizer needs become more urgent, since the increases make a heavier draft on the soil reserve of the plant-food elements.

Though there are many crops that can tolerate acidity, yet most of them will respond to liming because of the favorable conditions created within the soil by the added lime. It is, indeed, a deplorable fact, that in some sections farming without the use of agricultural lime represents much waste of time, money and effort.

**Illustration Material for Lessons.**—Show 3 forms of agricultural lime—burnt lime, hydrated lime and air-slaked lime (carbonate of lime).

Show 2 or 3 other lime carbonates.

Show a good grade of pulverized limestone, or other forms of agricultural lime.

**Demonstrations.**—*Material Needed.*—Several strips of blue litmus paper; a little vinegar; an orange; an apple; a little ammonia water; a pint each of strongly acid upland soil and undrained acid peat; a Truog soil-acidity testing outfit; a small baking-powder can; a bottle of muriatic acid; several materials containing lime carbonate; 12 tumblers; a 20-mesh screen; a 100-mesh screen; 2 tablespoonfuls of coarsely crushed limestone; and a teaspoonful of very finely pulverized limestone.

**To Demonstrate the Reaction of Acid Substances, Including an Acid Soil, on Blue Litmus Paper.**—*Procedure.*—With blue litmus paper test the reaction of vinegar, of water, ammonia water, apple juice, orange juice, and of strongly acid soil.

*Question.*—When is a soil said to be acid or sour?

**To Demonstrate the Truog Acidity Test.**—*Procedure.*—Follow directions accompanying testing outfit.

A. Demonstrate the reaction of a strongly acid soil.

B. Test the same soil, only use hard water instead of distilled water. Explain results.

**To Demonstrate the Nature of Soil Acidity.**—*Procedure.*—A. Fill a small baking-powder can with an acid sandy soil. (Perforate the bottom and place a piece of cheese cloth over the bottom.) Allow about 4 quarts of hot soft water to percolate through the sand. Dry a sample and retest for acidity. Compare the results with first test.

*Question.*—Why is it not possible to wash out the “acidity” in the sandy soil?

B. Repeat the experiment and use an undrained acid peat soil. Explain results.

**To Show How to Test for a Carbonate.**—*Procedure.*—Put a teaspoonful of lump lime into a tumbler and pour on it about a tablespoonful of dilute muriatic acid. Repeat test and use air-slaked lime, limestone, shells, coral, etc.

**To Demonstrate that the Fine Material in Pulverized Limestone is the Quick-acting Material.**—*Procedure.*—A. Obtain about 2 teaspoonfuls of crushed limestone (from a sample of pulverized limestone) that will not pass through a 20-mesh screen. Wash this coarse material thoroughly several times with acidulated water to remove all adhering fine particles. Obtain a teaspoonful of fine material that will pass through a 100- or 200-mesh screen. Fill a tumbler half full of water and add a few drops of muriatic acid to make distinctly acid to blue litmus paper. Mix thoroughly. Pour one-half of the acid solution into a second tumbler. Into one put the two teaspoonfuls of coarse particles of limestone, stir, and let stand 30 or 45 minutes, then test

again with blue litmus paper. Into the other tumbler pour the teaspoonful of the fine material, stir for a few seconds, and test with blue litmus paper. Explain results.

*B.* Repeat the test but use pure gypsum (calcium sulfate) instead of the finely pulverized limestone.

**Laboratory Exercises.**—*Material Needed.*—Several small strips each of blue and red litmus paper; 8 tumblers; about a cupful each of 3 soils to test for acidity; a half cupful each of a common salt solution, soapy water, vinegar solution sweetened with sugar, and sour milk or whey; four or five saucers; a piece of window glass; a small amount of pure gypsum (calcium sulfate); 4-quart samples of agricultural limes; a bottle of muriatic acid; and a quart of coal ashes.

**To Determine the Reaction of Different Solutions by the Use of Litmus Paper.**—*Procedure.*—*A.* Dip a small piece of blue litmus paper into an acid solution provided. What happened? Try a piece of red litmus paper. Any reaction? Acid turns blue litmus paper red.

*B.* Dip a piece of blue litmus paper into an alkaline solution. Any reaction? Test with a piece of red litmus paper. What change takes place?

An alkaline solution turns red litmus paper blue. An alkaline solution has an opposite reaction to that of an acid solution.

*C.* Test pure water with blue and red litmus paper:

Water is a neutral material, neither acid nor alkaline.

*D.* By the use of blue and red litmus paper determine the reaction of the following solutions:

A common salt solution; soapy water; vinegar solution sweetened with sugar; and sour milk or whey.

*Question.*—What is litmus?

**To Test for Soil Acidity by the Use of Blue Litmus Paper**—*Procedure.*—

*A.* Place about 3 tablespoonfuls of soil in a clean saucer and moisten to a thick mud with clean, soft water, previously boiled. With a clean stick separate the mud into two portions and lay on one portion a piece of blue litmus paper. Press the other portion of wet soil firmly down on the paper; leave for about 3 to 5 minutes, then carefully remove the upper portion of the soil and examine the paper. Note results, and interpret.

*B.* Test another soil, but this time place the piece of blue litmus paper between the two halves of a mud ball.

*C.* Test a third soil. This time lay litmus paper on a piece of window glass, and cover with one-half of a mud ball.

**To Show that Lime Will Correct Soil Acidity.**—*Procedure.*—*A.* Place about three tablespoonfuls of acid soil in a clean saucer and thoroughly mix with it about a quarter of a teaspoonful, or less, of air-slaked lime. Moisten the mixture and test with blue litmus paper as before. (Select either one of the three methods.)

*B.* Repeat and use pure gypsum (calcium sulfate) instead.

*Question.*—What effect did the lime have on the acid soil?

**To Study Different Forms of Agricultural Lime.**—*Procedure.*—Examine carefully the samples of different agricultural limes provided and record facts and observations in tabular form as follows:

Common name	Carbonate, hydrate or quick lime	Application per acre	Cost per ton	Characteristics: color, fineness, moisture content, carbonate content

Test the different materials for carbonates by placing about a quarter of a teaspoonful in a tumbler and pouring on a few drops of dilute muriatic acid.

*Questions.*—(a) What kind of gas is given off when a carbonate is treated with acid?

(b) What becomes of much of this gas after it escapes into the air?

(c) What is a carbonate?

(d) Name three carbonates.

(e) What kinds of carbonates are present in pure limestone, wood ashes, and air-slaked lime?

(f) Would you use coal ashes as a neutralizer for acid soils? As a fertilizer?

**Home Experiments or Projects.**—*Object.*—To demonstrate the profitable use of agricultural lime on acid soil for alfalfa, clover, lespedeza or peas.

*Procedure.*—Select an acre or half an acre of well-drained acid soil. Divide into two portions. Thoroughly lime one plot and leave the other plot unlimed. Sow alfalfa, peas, lespedeza or common medium red clover. Inoculate both plots. Determine to what extent the use of lime increased the value of the land as an income producer. (Consider the crop grown.) Determine net profits in the use of lime (Fig. 149).

**To Demonstrate the Need of Both Lime and Phosphate on a Long-cropped Acid Soil.**—*Procedure.*—Select an area of acid soil, divide into two strips, and lime, as described in above project. After the lime is thoroughly mixed into the soil by disking, apply acid phosphate on one-half of each strip at the rate of 300 pounds per acre. “Drag” the fertilizer into the soil. Plant corn the first year, grain the second, and clover the third. Apply 200 pounds of acid phosphate for grain the second year. Apply the fertilizer to the same end receiving the phosphate for corn. Do not fail to inoculate the whole area for the clover.

Determine the net profits from liming and the use of lime and phosphate for the 3-year period.

**Field Studies.**—1. Collect sample of soils from a few fields showing indications of acidity and test for acidity either in the field or laboratory.

2. Collect samples of soil from areas growing good clover or alfalfa and from areas where the clover or alfalfa failed or is growing poorly. Test the soils for acidity.

## QUESTIONS

1. What is the meaning of soil acidity?
2. Why is soil acidity harmful? How can this condition be corrected?
3. What is meant by liming? Agricultural lime?
4. Discuss the beneficial effects of liming.
5. Under what conditions does green manuring give best results?
6. What crops in particular give most direct profits from liming? Name other crops benefited directly by liming.
7. Name several crops especially adapted to “acid agriculture.”
8. Besides clover, a farmer grows corn, wheat, oats and timothy in a five-year rotation on acid soil. If he were to lime his land could he expect profitable returns from the other crops as well as from the clover? (Table, page 231.)
9. How may acid soils be determined?
10. Describe the blue litmus paper test for acidity.
11. How may certain weeds indicate acidity?
12. What relation is there between soil acidity and low wet lands? Discuss this point.
13. How do soils become acid?
14. How extensive are acid soils?
15. Can soil acidity be reduced through leaching? Explain.

16. Name several kinds of agricultural lime. Into what three groups may they be classified?
17. What is limestone and how is it prepared for agricultural use? What is a test for limestone, or for any carbonate?
18. What may be considered standard fineness for pulverized limestone?
19. When may farmers find it economical to pulverize their own limestone?
20. What is air-slaked lime? How does it differ from limestone?
21. What is marl? Waste lime? Tell of their values.
22. What are lump lime, ground lime and hydrated lime?
23. What may be said of lump lime for liming?
24. What is land plaster? Can it be used to correct soil acidity?
25. Compare the value of lump lime, hydrated lime and carbonate of lime as regards lime content, neutralizing power and quickness of action.
26. What is the best material to use for liming?
27. How much lime should a farmer apply to his acid soil?
28. What facts should guide in determining the time and manner of applying lime?
29. How may agricultural lime be applied?
30. Should a farmer apply lime as a top-dressing?
31. How often should lime be applied?
32. Why cannot a farmer, instead of liming, plow deep and turn up the carbonate of lime leached from the surface soil?
33. Can residual limestone soils become acid? Explain.
34. Does soil acidity have any direct injurious effect on the roots of plants? Discuss.
35. Is it necessary to inject lime into the subsoil for best results? Explain.
36. Under what conditions can alfalfa grow well on acid soils without any special treatment? In such cases does liming prove beneficial?
37. A farmer finds his soil requires the equivalent of six tons of pulverized limestone to completely neutralize the acidity in the seven inches of surface soil. Is it necessary to add that much lime in the first application?
38. What gave rise to such a saying as "Lime enriches the father and impoverishes the son"?
39. Discuss the proper use of lime in relation to soil improvement and fertility maintenance.
40. Give an account of a particular case of liming about which you know. Give the effects.

### PROBLEMS

1. Determine the per cent increase in net profits per acre per rotation due to liming for each of the fertilizing treatments indicated in the table, page 231. Determine the net profits per acre in the use of lime alone.
2. About how many tons of lump lime may be made from twenty tons of good limestone?
3. A small field 12 rods square is to be given an application of one ton of lump lime to the acre.
  - (a) How many pounds of lump lime would be required?
  - (b) For convenience, the lime is to be spread from small piles placed two rods apart each way. How many piles should be made in the field? Draw a diagram of the field to a scale of one-fourth inch equals a rod, and indicate the placing of the piles.
  - (c) When each pile becomes thoroughly air-slaked, how many pounds of material would there be in each pile? The application of lump lime would be the equivalent of how many pounds of carbonate of lime for the field?



## CHAPTER XIV

### HARMFUL AGENTS IN SOILS AFFECTING FERTILITY

“ABSENCE of harmful agents in soils” is the one negative factor named with the positive factors determining soil fertility. Water, air, good tilth, helpful soil organisms, and available nitrogen, phosphorus, potassium and sufficient lime are all necessary to create within the soil the power for producing large crops; but the presence of any harmful agents may nullify the effect of all these positive factors. In considering a case of low yield or infertility, it is important, therefore, not only to examine into the positive factors determining fertility, but that investigation be extended to a consideration of harmful agents within the soil as well. Some of these harmful agents are discussed in the following paragraphs—not fully but sufficiently to illustrate the importance of this negative factor.

**Worms and Insects May Destroy Crops.**—Frequently a farmer is at a loss to know why some particular crop should “stand still” or fail when all conditions seem favorable. The white grub, wire worm, the corn rootworm, the maggot, and eel worms or nematodes are common “worms” that live in the soil and which often injure crops by feeding on their roots.

*White Grub.*—In some fields, as in southwestern Wisconsin, northeastern Iowa and northwestern Illinois, the white grub often causes complete loss of the corn crop. It may also cause much injury to timothy, potatoes, lawns, strawberries and beans. These grubs are the larvæ, or the young, of the May beetles or “June bugs.” They feed on the roots of various plants and on potato tubers. Early October plowing will destroy many of these grubs.

*The wire worm* is the young of the click beetle, and is generally harmful to corn on old sod. These worms, like the white grub, live in the soil two years before they change into the beetle form. This explains why the wire worm often causes more injury the second year after an old sod is broken than the first year.

*Corn Rootworm.*—Corn growers in the Southern states, particularly, suffer much damage from the corn rootworm or “budworm.” In some seasons it is difficult to get a stand of corn in the lowlands on account of these worms which are but the young of the twelve-

spotted cucumber beetle. These worms are slender and yellowish-white with a dark-brown head. They not only feed on the corn roots, but in young corn they bore into the stems and eat the interior, boring out the crown, and killing the bud. Burning over waste places and growing other crops on fields badly infested, thick planting and enriching the soil are suggested remedies.

*Root Maggot.*—Some truck crops, such as cabbage, radish and onions, are injured by the maggot (Fig. 161). Other crops are injured by eel worms or nematodes which cause the root-knot



FIG. 161.—Injurious work of maggot on radish. (Geneva Station, N. Y.)

disease, as on cabbage and tomato (Fig. 162). The growing of other crops has been found the most effective remedy.

*The aphid* (*ā'fīs*) is a common insect which injures crops. There are many species, many of which feed on the juices of plant roots.<sup>1</sup> The corn root-aphid, or root-lice, is perhaps the best known. Ants are largely responsible for aphid injury to roots, since they carry the eggs of these insects into the soil and care for them in their nests. When the eggs hatch the ants tunnel into the ground and place the helpless aphids first on the roots of certain weeds, such as smart weed, then on the corn roots (Fig. 163). Aphids are often called "ant cows." Since the corn root-aphid

<sup>1</sup> Cotton and asters are also commonly injured by the corn root-aphid.

usually attacks corn that is grown continuously on the same land, crop rotation is an effective means of control. Another complete and effective means of controlling the corn root-aphis is thorough stirring of the soil previous to planting, to disturb the ant colonies and scatter and kill the aphids.



FIG. 162.—Roots of tomato plant affected with root-knot. (Florida Station.)

**Crop Diseases May Cause Failure.**—A great many diseases attack plants. Many of them are caused by fungi and bacteria which live in the soil; among which may be mentioned potato scab, pea blight,<sup>2</sup> wilt, root rot, cabbage yellows, brown rot in tomatoes, black-leg in cabbage and cauliflower, and club root (Fig. 164), soft rot and black rot, as in cabbage. Rotation of crops and avoiding

<sup>2</sup> Pea blight fungus stays in the soil so long as diseased tissue of the pea plant remains in the soil. Potato scab on the potato may be treated, but when soils become infested with the scab fungus other crops should be grown.

disease infested fields are remedies suggested to control these diseases or to avoid injury from them. Sometimes plants may be developed that are resistant to certain diseases. Cabbage resistant to yellows is a good illustration (Fig. 165).

**Too Much Water Is Harmful.**—On lowlands the harmful effect of too much water is commonly observed, but the lack of proper drainage on some upland fields having good surface drainage is very often least suspected. Frequently certain fields or portions of them are found to grow good crops of hay and grain

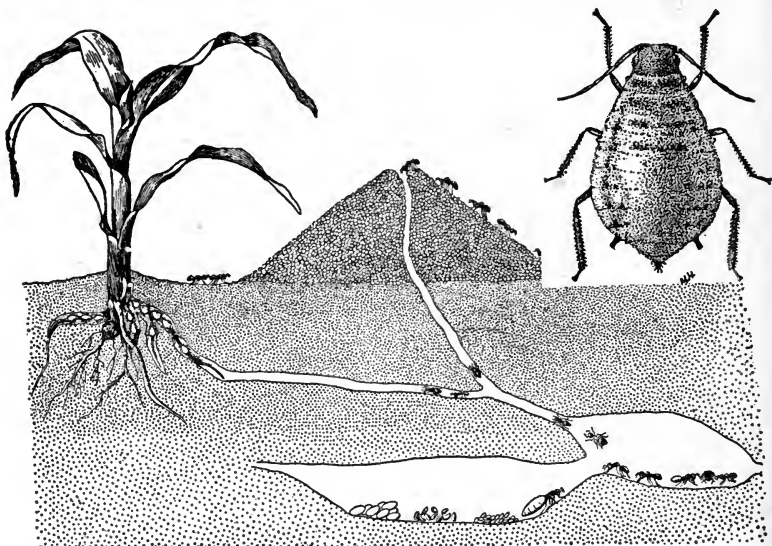

FIG. 163.—Diagram showing how ants foster the corn root-aphis. Upper right, the corn root-aphis, enlarged. (U. S. D. A.)

but fail in growing corn, in spite of the fact that manure and fertilizers may have been added. In almost every case the cause of the poor corn is due to seepage water from higher land, which keeps the subsoil too wet and cold to favor the growth of corn. Tile drainage is the remedy (Fig. 166).

**Alkali Is Injurious.**—In regions of deficient rainfall, alkali in soils often proves injurious, and in some sections in humid climates, alkali spots occur. Frequently the irrigation of land in irrigated sections causes the accumulation of salts near the surface (being brought up from the subsoil through capillary rise of applied moisture) in sufficient amounts to cause the most fertile lands to

become unproductive. Other lands in the arid and semi-arid sections are so saturated with alkali salts naturally that they are barren, and are not fit lands for irrigation. The permanent remedy consists in removing the injurious salts by means of tile drains, scraping it off, and by flooding. The growing of alkali-resisting crops, such as salt grass, has been suggested as a means of avoiding injury. Sweet clover grows well when alkali is quite abundant. As a general rule, deep rooted plants can tolerate alkali soils better than those that are shallow rooted. Land-plaster is sometimes used to neutralize black alkali, the most harmful of the alkali salts (sodium carbonate). Retarding evaporation by mulching and shading, and deep plowing may retard the accumulation of salts at the surface.



FIG. 164.—Club-root of cabbage, showing swollen and distorted roots and undeveloped head. (Vermont Station.)



FIG. 165.—A soil infested with cabbage yellows. A strain of cabbage has been developed to resist this disease. Two rows to left are non-resistant cabbage. (Wisconsin Station.)



FIG. 166.—Unproductive spot on a low field due to high water-table. Variation in subsoil the cause of the difference in water-table.

**The Toxin Theory of Infertility.**<sup>3</sup>—A few investigators are supporting the theory that infertility of many soils is due largely to the presence of certain poisons or toxins which probably owe their origin to plant-root excretions and to decomposition of soil organic matter. The supporters of this theory maintain that the beneficial effect of fertilizers on poor soils is due to the power of the fertilizers to neutralize or counteract the effect of these toxins, rather than to the available plant-food elements added.

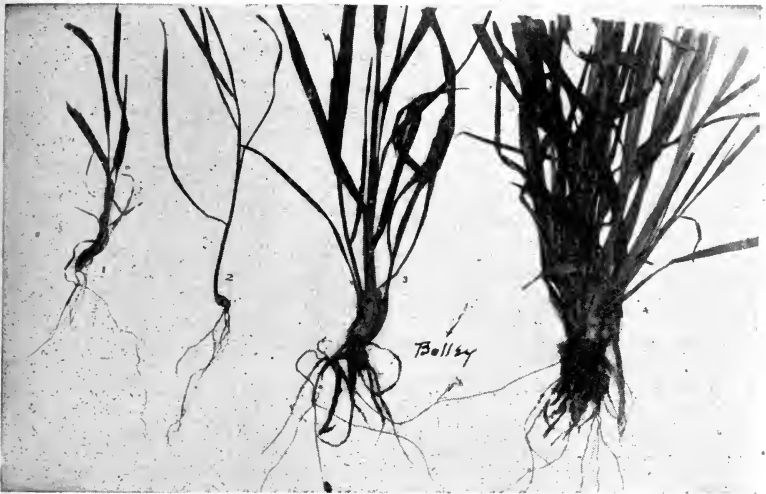

FIG. 167.—Diseased wheat on wheat-sick soils. Dead roots and blighted leaves. Soil 40 years in wheat. (North Dakota Station.)

They have presented data endeavoring to show that increasing the amount of available plant-food elements through the use of fertilizers has practically nothing to do with the maintenance of soil fertility. This theory, however, has been accepted by only a few, since other investigators have shown definitely that soils which produce large yields contain more available plant-food material than do soils that produce low yields. Furthermore, numerous field tests have demonstrated that crops on poor land are directly benefited by fertilizers and lime.

Nevertheless, it is conceded that some toxins do form in soils

<sup>3</sup> Conclusions drawn by Whitney and Cameron of the Bureau of Soils, United States Department of Agriculture.

and which may prove injurious to certain crops and fruit trees if allowed to accumulate. Recent investigations seem to show that most soils are so constituted that through good drainage, proper tillage and the presence of sufficient lime the injurious action of these toxins may be entirely or in a large measure prevented.

**Other Harmful Agents.**—Among other harmful agents that have been named in certain instances to explain low yields or failures are: (a) An excessive amount of aluminum and iron in soils renders some of the plant-food elements unavailable. The effect of soluble phosphates on certain red, tropical soils is of short duration because of the presence of excessive amounts of iron and aluminum; (b) too much magnesium in proportion to calcium may disturb the normal function of plant cells; (c) too much lime in some soils may prove harmful to some crops, as grape-fruit, pineapple and certain lupines; (d) certain mineral acids may make soils sour; (e) it is advocated by some that certain soil micro-organisms accumulate to such an extent that they greatly retard the activity of the helpful soil organisms.

**Collect specimens** showing the work of insects which attack roots of crops in any way. Specimens of these insects may be collected and preserved according to directions given in many good insect books.

**Diseased root specimens** of field crops may be brought to class and kept for study.

**Projects in growing crops** in spite of insects and diseases should be conducted, using the most approved methods in each case.

### QUESTIONS

1. What negative factor should be considered in diagnosing a case of infertility?
2. What may some of these agents be?
3. Discuss infertility due to worms which feed on plant-roots.
4. Name methods of control.
5. What is the corn root-louse?
6. Name some plant diseases caused by certain fungi and bacteria that live in soils.
7. How may a farmer avoid crop failure due to these diseases?
8. Explain how too much water within soils may prove a harmful agent.
9. Suggest a remedy.
10. Illustrate by diagram.
11. Discuss the relation of alkali to soil fertility.
12. What is the toxin theory of the infertility of many soils?
13. What are toxins?
14. According to this theory, what is the action of fertilizers?
15. Do any poisonous substances form in soils? How?
16. What do recent investigations seem to show as regards these toxins?
17. What harmful agents in soils do you know from your own experience or observation?



## CHAPTER XV

### CROP ROTATION AND ITS RELATION TO SOIL FERTILITY

**Crop Rotation Defined.**—Crop rotation is a system of growing different kinds of crops in recurring succession on the same land. For example, on a certain field a farmer grows clover one year, corn the second, oats the third, clover the fourth, corn the fifth, oats the sixth, etc. This is a three-year rotation, since each crop recurs every third year. Another farmer may grow these same crops in a rotation as follows: clover followed by corn, then another crop of corn, which in turn is followed by grain seeded to clover. This is a four-year rotation since it requires four years for the complete succession of these crops to recur.

Some systems of cropping are designated as *fixed* rotations, and others as *definite* rotations.

A **fixed rotation** is a system of cropping in which the different crops recur at regular intervals, and which occupies a fixed number of years. Clover followed by potatoes, then rye seeded to clover, is a good example of a fixed three-year rotation practiced by some potato growers on sandy soils. Some fixed rotations may occupy four years, others five and six years or more.

A **definite rotation** may be defined as a system of cropping in which the different crops continually recur in a definite order, but is not fixed as to the number of years it occupies. Many farmers, for example, grow alfalfa, corn and grain on the same land in the order named, in anything from a five-year to a ten-year rotation—alfalfa three to six years, corn one to two years, and grain one to two years. Another common, definite rotation is, hay (clover) followed by pasture, then corn, then grain seeded to clover and grass. In such a rotation the land may be pastured one to three years.

Very often in a rotation some one crop is grown two or more years in succession; as, tobacco (three years), followed by wheat (one year), clover (one year), tobacco (three years), etc.

**Nearly all farmers practice crop rotation** in some form or other. Comparatively few adhere to fixed rotations, since they prefer to follow a cropping system that is more or less flexible so that a shift can be made when prices or seasonal variations should make

necessary a change in the cropping plan. Moreover, varying soil conditions and the desire of the farmer to meet feeding requirements often prevent the establishment of a fixed rotation for the entire farm.

**One-crop System.**—In contrast to crop rotation is the *one-crop* system in which one kind of crop is grown year after year on the same land. This is often called “continuous cropping.” There are many examples of this in the corn belt, wheat belt, cotton belt, etc.

**Why Crops Are Rotated.**—Crop rotation has largely been the outgrowth of farming experience. Its beneficial effects have long been known, though the reasons were not understood. Even today some of the effects of crop rotation are not clearly understood. The primary object of rotation is to increase crop production and to help maintain productive farming. This is the cumulative effect of several specific benefits derived through this practice, which are: (a) It helps to eliminate injury due to certain insect pests; (b) it aids greatly in avoiding injury from certain diseases; (c) it favors the accumulation of soil organic matter; (d) tilth may be improved; (e) it favors the conservation of fertilizing elements; (f) it aids in solving certain liming and fertilizing problems; (g) weeds are better controlled.

**Rotation Controls Certain Insects and Plant Diseases.**—Many truck growers, particularly, much prefer to grow certain crops continuously on the same land, because when the soil is fitted to meet the requirements of a special crop it is easier to succeed with it. This explains the tendency to grow crops like cabbage, sugar beets, onions, and in some localities, potatoes, on the same land several years in succession. Though it is convenient at times to practice a one-crop system with certain crops, yet general experience teaches that it is a wiser plan to practice rotation, since many records show that certain pests and plant diseases finally compel the farmer to rotate. Some crops are especially attacked by certain soil-dwelling insects or are peculiarly susceptible to certain diseases which may infest the soil. The continuous growing of one crop favors the development of some such insect or disease until finally the crop is unable to resist its attacks. The growing of other crops not affected by the particular insect or disease must necessarily result in the soil becoming rid of the insect or disease, because these other crops do not favor its development nor its continuance in the soil.

Some potato growers have experienced the destructive effect of potato scab on fields growing potatoes continuously (Fig. 168). This disease can be prevented through seed disinfection; but when the soil is allowed to become infested by planting untreated, scabby potatoes, no remedy is so effective as crop rotation in eliminating the disease. The unfortunate experience of the pioneer farmer in growing wheat continuously on the same land might well be remembered as a warning against the one-crop system.

**Proper Rotation Increases Organic Matter.**—It is a striking fact that the growing of intertilled crops greatly hastens the destruction, and hence the loss, of the soil organic matter. It is not wise, therefore, especially on soils low in organic matter, to



FIG. 168.—Scabby potatoes the result of no clover or green manuring in rotation (sugar beets, cabbage, potatoes). This condition developed in six years. No scab on potatoes grown in rotation with clover. (Clover, potatoes, corn, oats.)

practice a rotation consisting of all intertilled crops, without the introduction of clover, other legumes, and green-manuring crops to maintain the supply of this very necessary soil constituent. A rotation including clover or pasture, and in which manure and green-manuring, or catch and cover crops are systematically used, increases the soil supply of organic matter. The introduction of non-cultivated crops such as grain, hay and pasture, lessens its destruction, and the use of manure, the development of good sod (Fig. 169), and the plowing under of green crops are ways to add it to the soil. A carefully planned crop rotation is the most convenient method whereby something definite may be done to maintain the soil organic matter. It is entirely possible for practically every farmer to plan a rotation or rotations which will enable him to accomplish this.

**Proper Rotation Improves Tilth.**—The rapid depletion of the soil organic matter resulting from the growing of crops without clover and without the use of manure and green-manuring crops has a destructive effect on good tilth. Sandy soils become much looser; and the heavier soils lose their crummy structure, becoming more compact, and easily puddled when worked in a wet condition. A rotation which maintains and builds up the supply of organic

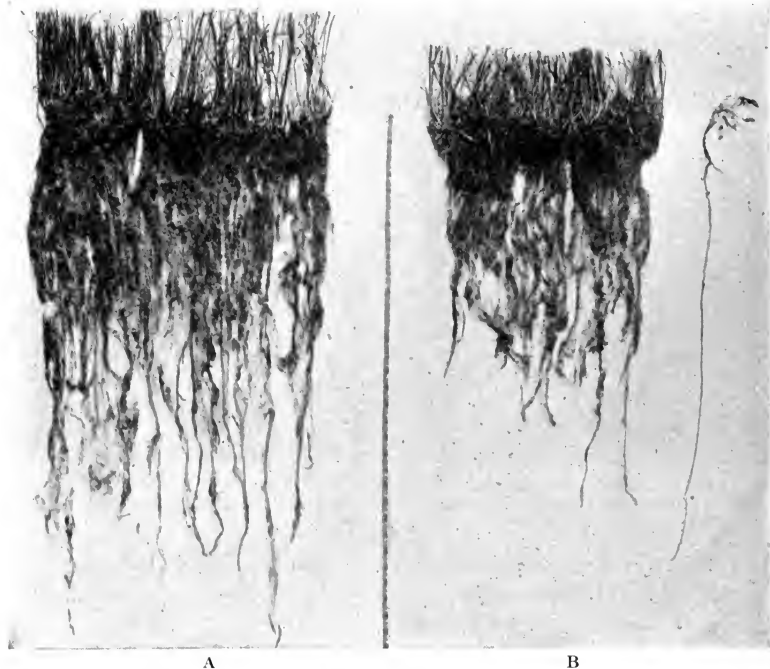

FIG. 169.—The development of good sod increases the soil organic matter. *A*, root development on land properly fertilized; *B*, root growth on same land but unfertilized.

matter in the soil also improves the workability of soils and maintains good tilth. The growing of grass, pasture and deep-rooted legumes on heavy soils greatly aids in improving their tilth.

On a portion of a field (silt loam) at the University of Illinois, corn was grown continuously for forty years; while on another portion, during the same period, a three-year rotation was practiced, consisting of corn, oats and clover. The soil on the first portion has become compact, it "runs together" badly, and heavy

rains wash it considerably and pack it, forming a smooth, hard surface. The other portion, on which were grown clover, corn and oats in rotation, is mellow, has a crummy structure, and heavy rains do not affect it as they do the soil on the first portion. The difference in these two plots is largely the result of the growing of clover.

**Conserving Fertilizing Elements Through Rotation.**—Not all crops require the same amount of the different plant-food elements. Some are gross feeders, and others make heavy drafts upon one or two elements (see Table of Crop Constituents, Chapter VI). Cabbage and spinach, for example, quickly exhaust the soil of nitrogen. In a rotation it can be arranged that one crop requiring a large quantity of one element, or all of them, does not follow another of a like characteristic. Through rotation, therefore, the draft upon the soil reserve of nitrogen, phosphorus, and potassium may be equalized so that the productive power of soils may be prolonged.

The growing of such crops as tobacco and cabbage and all shallow-rooted crops without rotation causes heavy losses of plant-food elements through leaching. These crops require rich soils, and hence heavy fertilization becomes necessary. The soil is supplied with much more available material than the crops can use, and hence conditions are favorable for heavy losses through leaching.

In Wisconsin, a study was made of the phosphorus losses on sixteen tobacco fields. These fields were cropped, on an average, forty-six years—thirty of which were tobacco. During this time they received an average of thirty applications of manure at the rate of eighteen loads, or about twenty-seven tons, to the acre. These investigations showed that during the forty-six-year cropping period, this system of farming caused the loss (above that removed by the crops) of an amount of phosphorus per acre from the surface soil eight inches deep, sufficient to supply the phosphorus needs of at least seventy 75-bushel corn crops.

When deep-rooted crops such as corn, alfalfa, clover and vetch are grown in rotation with shallow-rooted plants, much of the fertilizing elements which leach down into the lower strata is utilized. Moreover, deep-rooted plants bring up considerable plant-food material that is, in turn, used by other crops. This is especially true when soils are more or less "open" in character.

**Rotation Aids in Fertilization and Liming.**—Rotation offers an opportunity to get the greatest returns from manure and commercial fertilizers by applying them to the crops which can make the best use of them. Much coarse, fresh manure or litter gives

best results when it is plowed under in the fall for corn. Under certain conditions the application of manure to the clover fields gives best results.

Some believe that liming tobacco lands results in lowering the quality of the leaf. Results do not seem to support this view, however. Furthermore, experiments have shown that tobacco responds readily to liming when grown on acid soils. When tobacco is grown on acid soil in a rotation containing clover, the lime need not be applied directly to the tobacco crop, but for the clover instead. In this way any possible injury caused by the direct effect of lime on tobacco may be entirely prevented. In case of potatoes, the lime may be applied in the rotation immediately following the potato crop. Other similar problems concerning liming and the use of fertilizers may be solved through rotation.

**Rotation Controls Weeds.**—It has been demonstrated as well as commonly observed that fields on which small grains are grown continuously become very weedy, and crops diminish in yield and even fail as a result. This is because most weeds go to seed in the time required for the grain to mature. The growing of intertilled crops is a most effective way to kill weeds, especially those such as quack grass and Canada thistle. The growing of good clover and alfalfa, or any other leafy forage crop, is another effective way to kill the common weeds and keep them under control. A rotation containing at least a cultivated crop and one good clover crop gives the farmer at least two good chances in his system of cropping to fight the weeds.

**Rotation Helps to Maintain and Increase Fertility.**—In the foregoing discussion it is plain that a proper rotation of crops affects favorably, either directly or indirectly, practically all the factors which determine soil fertility. When these factors are thus affected, soils necessarily produce better crops. In this manner, therefore, rotation aids in maintaining and increasing fertility—that is to say, crop rotation helps to maintain and increase the productive power of soils. The productive power of a soil is reduced more rapidly when a crop is grown on it continuously than when a rotation is practiced. Among the many rotation experiments that may be cited to prove this, those in progress at the University of Illinois may be selected as typical. The following results are available from the oldest rotation experiments in America. These plots are located on brown silt loam, the typical prairie land of the corn belt. (Illinois Station circular No. 193.)

*Crop Rotation Helps to Maintain Productive Power of Soils*

(No soil improvement treatment of any kind made)

Year the experiment was begun	Cropping system	Yield after 36 years, 10-year average 1906-1915			Per cent greater crop value per acre over no rotation (average for 10-year period, 1906-1915)
		Clover	Corn	Oats	
1879	Corn continuously	<i>Tons</i>	<i>Bus.</i>	<i>Bus.</i>	
	Corn and oats in rotation . . . . .	. . . .	28.8	. . . .	. . . .
	Clover, corn and oats in rotation	. . . .	37.5 *	38.0 *	18.0
		1.69	57.6 †	33.4 ‡	36.7

\* Five-year average. † Three-year average. ‡ Four-year average.

The yield of corn at the beginning of the experiment was seventy bushels. After thirty-six years of continuous corn culture this yield was reduced nearly 59 per cent; and only 17.7 per cent reduction occurred when corn was grown in rotation with clover and oats. The first twelve years of continuous corn growing reduced the yield to thirty-five bushels, after which the decrease amounted to only eight bushels in sixteen years. It is thought that the rapid reduction in yield during the first twelve years was due, in a large measure, to the destruction, and hence depletion, of the soil organic matter.

The fact that the average annual crop value per acre for the ten-year period, 1906-1915, was 36.7 per cent greater when clover, corn and oats were grown in rotation than when no rotation was practiced is further proof of the advantage of a rotation in maintaining a higher productive power. The higher average crop value for the clover-corn-oat rotation over the corn-oat cropping plan was due largely to the increased yield of corn produced by growing clover in the rotation, and not to the value of the clover as a money crop.

Many farmers have experienced more profitable crops when they substituted a rotation for a one-crop system, or when a good rotation coupled with a definite plan of fertilizing is put into practice on a depleted soil. This latter point has been definitely demonstrated in an experiment started in 1894, at the Ohio Station, on silt loam soil which had been previously rented for twenty-five years, and hence badly depleted (Bulletin 282).

*Proper Rotation With Use of Fertilizers Increases Productive Power of a Depleted Soil*

(Yield of corn grown in a 5-year rotation)

Cropping system	Soil treatment	Average yield for first 5-year period 1894-1898	Average yield for fourth 5-year period 1909-1913	Decrease and increase in yield in 20 years (per cent)
Corn continuously	No treatment . . . . .	<i>Bushels</i> 26.26	<i>Bushels</i> 8.44	67.8 decrease
Corn in 5-year rotation*	No treatment . . . . .	31.89	20.31	36.3 decrease
Corn continuously	Commercial fertilizers (mixed) . (250 lbs. per crop)† . . . . .	38.86	26.83	30.9 decrease
Corn continuously	Manure (5 tons per acre per year) . . . . .	43.13	30.22	30.0 decrease
Corn in 5-year rotation	Commercial fertilizers (mixed) (985 lbs. for each 5-year period)‡ . . . . .	35.78	44.10	23.2 increase
Corn in 5-year rotation	Manure on corn and wheat (8 tons per acre, or 16 tons per rotation) . . . . .	40.73	55.83	37.0 increase

\* Rotation consisting of corn, oats, winter wheat, clover and timothy grown in the order named.

† Sixty pounds of acid phosphate, 30 pounds of muriate of potash and 160 pounds of nitrate of soda applied annually.

‡ One hundred sixty pounds of acid phosphate and 80 pounds each of muriate of potash and nitrate of soda applied to corn and oats crop; and 160 pounds acid phosphate, 100 pounds muriate of potash, 25 pounds dried blood and 60 pounds nitrate of soda applied to each wheat crop.

It is interesting to note that the yield of corn decreased thirty per cent in twenty years when grown continuously, even though manure was applied at the rate of twenty-five tons for each five-year period. In the rotation, on the other hand, the yield increased thirty-seven per cent during the same period, manure being applied at the rate of only sixteen tons for each five-year period. Similar results were secured in the use of commercial fertilizers.

The above results also show that rotation without fertilization does not permit so rapid a reduction in the yield of corn as continuous cropping. Moreover, rotation gives greater returns from manure and commercial fertilizers than a one-crop system.

In the same series of experiments it is interesting to note how rotation increased the yield of winter wheat.



*Crop Rotation Increased the Yield of Winter Wheat.\**

Cropping system	Fertilizer treatment	Average annual yield per acre for period 1894-1898	Average annual yield for the third 5-year period, 1904-1908	Decrease and increase in 15 years (per cent)
Wheat continuously	No treatment	<i>Bushels</i> 10.08	<i>Bushels</i> 6.19	38 decrease
Wheat in 5-year rotation	No treatment	9.28	13.66	47 increase§
Wheat continuously	Fertilizers (mixed)†	19.78	17.41	12 decrease
Wheat in 5-year rotation	Fertilizers (mixed)‡	20.53	33.10	61 increase

\* Ohio Experiment Station bulletin 231, 1911.

† One hundred sixty pounds each of acid phosphate and nitrate of soda, and 100 pounds of muriate of potash applied annually to the wheat crop.

‡ Fertilizers applied 3 times in each 5-year period—80 pounds each of acid phosphate and muriate of potash to each corn and oat crop, and each wheat crop received the same treatment as given each crop of wheat in continuous culture.

§ It cannot be assumed that this increase on the unfertilized plot will continue indefinitely.

Under the conditions of this experiment, rotation of crops is much more favorable to the growing of winter wheat than continuous cropping when yield and economy of production are considered.

**Rotation Can Not Take the Place of Fertilizers.**—Though a proper rotation is a most important farm practice to aid in maintaining and increasing soil fertility, yet it cannot take the place of manure and commercial fertilizers. Whenever crop rotation without fertilization increases the productivity of a soil, it is only temporary; because when the yields are thus increased, the draft upon the plant-food elements becomes greater, and this tends towards more rapid soil depletion. It becomes more urgent, therefore, to practice rational fertilization in order to secure the best results from rotations. The results in the tables, pages 270 and 271 emphasize this fact.

**Rotation Only One of Several Factors in Maintaining Fertility.**

—It is well to keep in mind the several factors involved in maintaining soil fertility, which are: (a) Thorough drainage; (b) proper tillage; (c) crop rotation; (d) liming; (e) a rational use of manure and commercial fertilizers, and (f) green manuring.

**A Simple Change of Crops Not Always Beneficial.**—Farmers have observed, and soil investigators have demonstrated, that a simple change of crops may not always prove beneficial. In some sections farmers experience unsatisfactory corn crops when grown after sugar beets. The North Dakota Station has found that on

the typical soil of the Red River Valley, spring wheat yields best when preceded by corn, potatoes, mangels, peas and clover; and when preceded by oats, barley, spring rye and flax, the yield was practically the same as when wheat was grown continuously.

Winter wheat does well after early potatoes, clover, alfalfa, soybeans and pasture. Onions do best after onions, except when certain insects or diseases become injurious. Corn usually succeeds best after clover, alfalfa and pasture. Oats on rich lands stand up better and yield best when they are grown after such crops as corn, wheat, barley and cotton. These are but a few illustrations to emphasize the importance of considering carefully the best combination of crops for rotation, and the place each crop should occupy in the rotation for best results.

**Factors Determining a Good Rotation.**—It follows that there are two factors which determine a good rotation, viz., a proper combination of crops, and the order in which these crops should be grown.

**Proper Combination of Crops.**—In general, the benefits of rotation can best be attained when the cropping system includes (a) a cultivated crop, (b) a grain crop, and (c) grass, clover or some other legume.

The growing of a cultivated crop aids in weed control, and in many instances improves the physical condition of the soil and prepares the land for the crop following. Corn, for example, is often grown two years in succession on blue-grass sod to eradicate the blue-grass in preparing the land for alfalfa. A cultivated crop also prepares the ground for grain.

The growing of small grain in the rotation greatly facilitates the seeding of grass, clover, etc., without losing the use of the land during the time required for the grass or clover seeding to become established for use as hay or pasture. In addition to their value as grain crops, fall-sown grains may serve as catch and cover crops, and frequently as winter pasture crops, of particular value in the South.

No rotation can give best results without a legume. Experiments show that crops can be produced most economically only when clover or some other legume is grown in rotation with them. In a twenty-year test at the Ohio Station, it was found that the average cost of the commercial fertilizers per bushel increase in yield was forty cents for corn, sixty-six cents for oats, and sixty-nine cents for wheat, when these crops were grown continuously

and without clover.<sup>1</sup> When these same crops were rotated with each other and with clover, the cost of the fertilizer averaged only four to five cents per bushel of increase.

**Proper Order of Cropping.**—Much depends upon the order in which crops are grown. Usually cultivated or intertilled crops are followed by small grains, which in turn, are followed by hay or pasture. Sod is commonly planted to some cultivated crop.

Aside from this order, it is important to know what cultivated crop is best to follow a certain other cultivated crop; or when two grain crops are grown in succession, which one should follow the other for best results. The growing of deep rooted plants after shallow feeders has already been suggested as an important consideration. In Central Kansas the growing of alfalfa (where it can be grown) leaves the ground so dry that it is usually not wise to grow corn after alfalfa, but rather an early maturing variety of sorghum instead. On rich bottom lands in this section, where the moisture supply is usually good, corn may follow the spring cutting of alfalfa. Other facts concerning the proper sequences of crops have been mentioned in a preceding paragraph, page 267.

**Crop Rotation and Soil Improvement.**—Crop rotation alone, even when clover is included, will not maintain yields, permanently. After awhile the clover fails, and as a result farming fails. Whenever a cropping system is planned to maintain or increase crop production it is essential that a definite soil-enriching plan be established at the same time. In some cases, clover and green-manuring crops are of the greatest immediate importance to increase and maintain the nitrogen supply and the organic matter. This seems to be true in the greater portion of the Great Plains area. Most soils, however, respond best and are improved the quickest when a carefully planned cropping system is established which embraces some definite plan involving the use of lime, manure, legumes and special fertilizers. These soil-improvement materials make possible successful crop rotation, and rotation, in turn, makes possible the most profitable returns from the use of lime, manure and fertilizers.

It is recognized that a short rotation is usually the most effective in soil improvement, largely because of the growing of more clover and the more frequent application of manure and fertilizers. The advantage of a short rotation in soil improvement is illustrated in the next table. These results were secured at the

---

<sup>1</sup> The Monthly Bulletin, Ohio Station, June, 1918.

Ohio Station (Bulletin 282). The experiments are being conducted on silt loam soils which were depleted when the tests were begun.

*A 3-year Rotation Better than a 5-year Rotation in Soil Improvement*

(As indicated by the yield of corn)

System of cropping	Soil treatment	Average yield for 20 years	Average yield for 17 years
		<i>Bushels</i>	<i>Bushels</i>
Corn continuously.....	No treatment.....	15.5	
Corn continuously.....	Manure, 5 tons per acre per year.....	37.0	
Corn in 5-year rotation *	No treatment.....	29.0	
Corn in 3-year rotation †	No treatment.....	....	35.2
Corn in 5-year rotation...	Manure, 8 tons twice in rotation—to corn and wheat..	51.8	
Corn in 3-year rotation...	Manure, 8 tons every third year—on corn.....	.....	60.2

\* Rotation of corn, oats, wheat, clover, timothy. (Crops grown in order named.)

† Rotation of corn, wheat, clover. (Crops grown in order named.)

It is to be noted that the average yield of the 3-year rotation without any soil treatment is 21.3 per cent greater than that of the 5-year rotation without manure. With manure, the 3-year rotation produced an average yield 16.2 per cent greater than that of the 5-year rotation. This is significant, since both are considered good rotations.

It is interesting to note that the average yield for the 3-year rotation without manure is almost as good as that of continuous cropping wherein five tons of manure are used annually.

#### SOME PRACTICAL ROTATIONS

Because of the great variety of crops, soil condition, climate, and of the varied combinations of crops in different systems of farming, many different kinds of rotations are practiced, some of which are recognized as standard. A few of these rotations are given here to show how important crops of the different sections of the country may be grown with best success. Most of these rotations include the use of manure and commercial fertilizers.

**Rotations to Increase Organic Matter.**—In beginning the improvement of most depleted soils it is best to practice a rotation that will increase the soil organic matter. In the Northern states a 3-year rotation of corn, grain and clover is common. Farther

south, as in the Central Atlantic States of the Coastal Plain section, the following rotation is considered a good one for soil improvement:

1. Cowpeas (plowed under), followed by rye (plowed under about May 1).

2. Cowpeas (cut for hay), followed by crimson clover (sown in the fall and plowed under about May 1).

3. Corn followed by crimson clover (sown at last cultivation and plowed under for other crops).

**Rotations for the North Central States.**—This group of states comprises Ohio, Indiana, Michigan, Wisconsin, Minnesota, Iowa, Missouri, Illinois, North Dakota, South Dakota, Nebraska and Kansas.

*The important crops*, named in the order of their importance on the basis of acreage are: Corn, oats, hay, winter wheat, spring wheat, barley, rye, flax, potatoes, peas, and tobacco.



FIG. 170.—The alfalfa acreage.

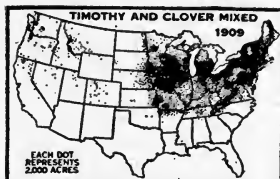

FIG. 171.—Timothy and clover mixed.

*The important legumes* and their adaptation are:

Medium red clover—for general use for hay and pasture. Grows best on soils well supplied with lime.

Alsike clover—adapted for low lands and for acid soils.

Mammoth clover—best for sandy soils and for green-manuring. Grows best on non-acid soils.

Alfalfa—grows best on well-drained rich uplands, well supplied with carbonate of lime (Fig. 170).

Soybeans—grow well on soils of slight to medium acidity.

Cowpeas—for southern portion of this section—grow well on acid soils.

A few common rotations are given, each being lettered. The crops in the rotation are numbered.

A—1. Corn. 2. Oats, wheat or barley (seeded). 3. Clover. Some other cultivated crop may take the place of corn. Clover is commonly mixed with timothy (Fig. 171) and other grasses to produce hay or pasture for the fourth year.

B—1. Corn (in which some green-manuring crop may be sown). 2. Oats (if prairie soil, oats disked in on corn land; seeded). 3. Clover—plowed in fall and sown to winter wheat. 4. Winter wheat (Fig. 172) (seeded with mammoth clover to plow under, or if soil has “tight” or heavy clay subsoil, sweet clover is better).

C—1. Corn for grain or silage. 2. Soybeans for hay or seed. (If soil needs organic matter this crop may be plowed under.) 3. Oats (Fig. 173) or barley (seeded to clover). 4. Clover. 5. Winter wheat (seeded to mammoth clover for green-manuring).

This rotation (C) is especially well adapted for loams and sandy loams.

D—1. Corn. 2. Oats (seeded to mammoth clover to plow under), winter wheat sown in the fall or spring wheat in the spring. 3. Wheat (seeded to clover or clover and mixed grasses). 4. Clover (often followed by pasture the fifth year).

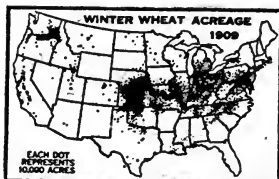

FIG. 172.—Winter wheat acreage.

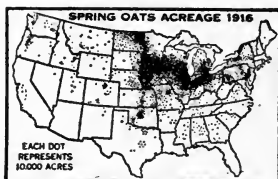

FIG. 173.—Spring oats acreage.

This rotation (D) proves very successful when soybeans, instead of oats, are grown the second year, as: 1. Corn. 2. Soybeans. 3. Wheat (seeded to clover). 4. Clover.

E—1. Corn. 2. Flax. 3. Wheat. 4. Clover. 5. Pasture.

F—1. Alfalfa (five to eight years). 2. Potatoes. 3. Flax. 4. Corn. 5. Wheat.

G—1. Alfalfa (three to four years). 2. Corn. 3. Grain. 4. Clover.

H—1. Clover. 2. Potatoes or corn. 3. Rye (seeded to mammoth clover).

I—1. Rye (seeded to mammoth clover). 2. Clover. 3. Corn (rye in corn for green-manuring). 4. Soybeans (rye sown in fall).

Rotations (H) and (I) are especially good in sand management.

J—1. Barley (seeded to clover). 2. Field peas. 3. Winter wheat. 4. Clover. 5. Corn.

K—1. Tobacco (Fig. 174). 2. Tobacco. 3. Winter wheat or barley. 4. Clover. Corn may be grown the second year, or follow the second tobacco crop.

L—In the spring-wheat section (Fig. 175), the following rotation has been recommended: 1. Spring wheat (three years). 2. Clover (one year). 3. Corn (one year).

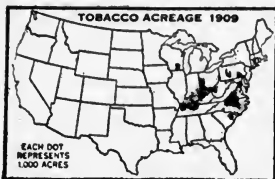

FIG. 174.—Tobacco acreage.

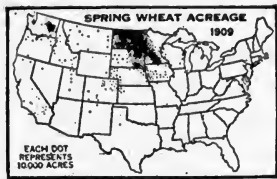

FIG. 175.—Where spring wheat grows best.

### Rotations for Dry-Land Farming.—(Great Plains area):

*Important Crops.*—Winter wheat, spring wheat, oats, corn, barley, hay, rye, kafir corn (Fig. 176), broom corn, sorghum and potatoes.

*Important Legumes.*—Alfalfa, red clover, soybeans, vetch, peas and cowpeas.

*Rotations.*—Little information exists on crop rotation for dry-land farming, since only recently has this subject been given any attention in the West. The following are some of the best rotations at present:

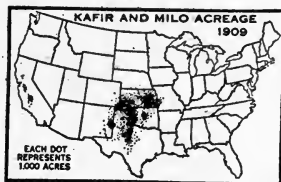

FIG. 176.—Kafir and milo acreage.

A—1. Corn. 2. Winter or spring wheat. 3. Oats.

B—1. Barley. 2. Oats. 3. Corn.

C—1. Summer fallow. 2. Winter wheat. 3. Oats.

D—1. Corn. 2. Corn. 3. Oats or wheat. 4. Wheat. 5. Clover.

In sections where medium red clover and corn cannot be grown, cowpeas may be substituted for the clover in rotation (D), and kafir corn for the corn.

E—1. Alfalfa (six to eight years). 2. Corn (one year). 3. Oats, barley or winter wheat (one year). 4. Winter wheat (three years). 5. Kafir corn or sorghum. If alfalfa leaves the ground very dry, an early variety of sorghum is best to follow the alfalfa. For sections in which the rainfall is especially scant the rotation should include summer fallow at least every third or fourth year.

**Rotations in the North Atlantic States.**—This group of states includes Maine, New Hampshire, Vermont, Massachusetts, Rhode Island, Connecticut, New York, New Jersey and Pennsylvania.

*Important Crops.*—Hay, oats, corn, winter wheat (Fig. 172), potatoes (Fig. 177), buckwheat, rye, peas, barley, and tobacco.

*Important Legumes.*—Red clover, alsike clover, mammoth clover, white clover, alfalfa, and peas (Fig. 178).

*Typical Rotations.*—A—1. Clover or pasture. 2. Corn. 3. Oats and peas. 4. Rye (seeded).

B—1. Corn for grain. 2. Corn for silage. 3. Oats and peas (seeded down to clover and timothy after harvest). 4. Hay.

In rotation (B) the oats and peas mixture may be omitted, and the clover and timothy is then seeded in the corn the second year at the last cultivation. Rye instead of oats and peas is often grown the third year in such a rotation as this.

C—1. Corn. 2. Potatoes (autumn rye). 3. Rye (seeded to clover). 4. Clover or pasture.

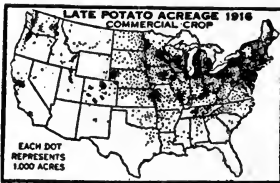

FIG. 177.—Late potato acreage.



FIG. 178.—Acreage of green peas.

D—1. Potatoes (rye sown in autumn). 2. Rye (seeded to mammoth clover for green-manuring).

This two-year rotation (D) is common in sections where potato raising is the main business.

E—1. Corn (rye as cover crop). 2. Tobacco. 3. Wheat or oats (seeded to clover and timothy). 4. Hay.

F—1. Tobacco (Fig. 174). 2. Oats (seeded to clover to plow under). 3. Winter wheat (seeded). 4. Clover.

**Rotations in South Atlantic States.**—Delaware, Maryland, District of Columbia, Virginia, West Virginia, North Carolina, South Carolina, Georgia and Florida are included in this group.

*Important Crops.*—Northern portion: Corn, winter wheat, hay, oats, tobacco, potatoes, rye, buckwheat and cotton.

Southern portion: Cotton, corn, oats, winter wheat, hay, tobacco, sweet potatoes, potatoes, rye and rice.

*Important Legumes.*—Cowpeas, crimson clover, soybeans, vetches, red clover, velvet beans, alfalfa, and alsike clover.

*Some Practical Rotations.*—A—1. Corn (crimson clover sown



in corn in late summer). 2. Clover (volunteer crop plowed under in autumn). 3. Winter wheat (seeded to clover and timothy). 4. Hay.

B—1. Corn (winter wheat sown in the fall). 2. Winter wheat (cowpeas for green-manuring). 3. Winter wheat (clover). 4. Hay or pasture.

C—1. Tobacco. 2. Winter wheat (clover). 3. Clover. 4. Corn with cowpeas.

D—1. Corn with cowpeas (winter oats). 2. Oats (clover). 3. Clover. 4. Potatoes (a green-manuring crop sown).

E—1. Cotton (vetch for winter cover crop or cowpeas). 2. Corn with cowpeas between rows. 3. Peanuts.

For the third year in this rotation (E) oats and vetch may be grown for a winter crop and cowpeas for the summer crop.

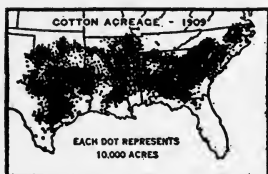

FIG. 179.—The South is for cotton.

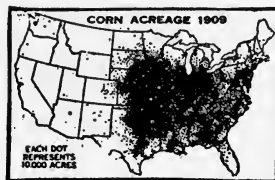

FIG. 180.—Where corn is grown.

F—1. Cotton. 2. Oats and vetch; cowpeas. 3. Cotton; vetch for winter cover crop. 4. Corn, with cowpeas between rows.

**Rotations in the South Central States.**—This group of states includes Kentucky, Tennessee, Alabama, Mississippi, Louisiana, Texas, Oklahoma and Arkansas.

*Important Crops.*—These are named in the order of their importance on the basis of acreage: Cotton (Fig. 179), corn, oats, winter wheat, hay, rice, tobacco (Fig. 174), sweet potatoes, sugar cane, rye and barley.

*Important Legumes.*—Japan clover (lespedeza), cowpeas, velvet bean, crimson clover, vetches, soybeans, medium red clover, alfalfa, and alsike clover.

*Rotations.*—A—1. Corn (Fig. 180) (cowpeas sown at last cultivation and plowed under). 2. Oats or rye (stubble plowed in summer, followed by cowpeas for feed). 3. Cotton (cowpeas, vetch or crimson clover sown between rows).

B—1. Cotton (cotton stalks plowed under early and winter wheat sown). 2. Wheat, followed by cowpeas or soybeans for

hay. 3. Corn and velvet beans (beans and corn stalks pastured and turned in early spring for cotton).

C—1. Corn with cowpeas (crimson clover for cover crop). 2. Soybeans or cowpeas (winter wheat sown in autumn). 3. Wheat (clover). 4. Clover.

D—1. Corn with cowpeas. 2. Cotton (cowpeas or clover).

E—1. Tobacco (rye for cover crop). 2. Corn. 3. Winter wheat (seeded). 4. Blue grass (two years).

F—1. Rice. 2. Rice. 3. Rice. 4. Fallow. 5. Corn and cowpeas.

G—1. Sugar cane. 2. Sugar cane. 3. Sugar cane. 4. Corn (cowpeas for green-manuring).

**Rotation for the Pacific States.**—*Important Crops.*—Hay, wheat, barley, oats, sugar beets, potatoes, corn and rye.

*Legumes.*—Vetches, clovers, alfalfa and peas.

*Some Common Rotations.*—A—1. Clover. 2. Pasture. 3. Corn for silage. 4. Oats. 5. Wheat (seeded).

B—1. Winterwheat. 2. Oats (vetch). 3. Vetch for hay. 4. Wheat (vetch for cover and green-manuring crop).

FIG. 181.—Where most of the sugar beets are grown.

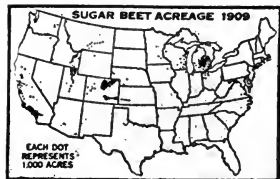

C—1. Barley (clover or vetch). 2. Peas (fall wheat). 3. Winter wheat (clover). 4. Kafir corn. D—1. Sugar beets (Fig. 181) (winter vetch). 2. Vetch crop plowed under, potatoes. 3. Barley (may be followed by alfalfa).

**Rotations for Truck Farming and Vegetable Growing.**—Rotations for truck farming and gardening have not been definitely determined. It is generally recognized that truck crops and vegetables are grown most successfully in rotation with clover or some other legume. In general, root crops should follow non-root crops, and legumes should follow non-legumes. Crops such as cabbage and sugar beets are best grown in rotation with common field crops. Wheat-clover-melons, or wheat-clover-corn-melons, are rotations well adapted for melons where wheat may be grown. Corn-cowpeas-muskmelons (heavily manured) is a rotation recommended for muskmelons. Some Eastern truck growers grow sweet corn and cabbage, followed by grain, then clover.

In vegetable gardening particular attention should be given to succession<sup>4</sup> and rotation of crops. Through succession of crops

<sup>4</sup> In gardening, succession of crops means following one crop with another of the same season, while rotation means changing the crop on a given piece of land from season to season.

the land may be utilized all the time. As soon as one vegetable matures or is used another one should be planted in the same space. For example: early peas may be followed by celery; early cabbage

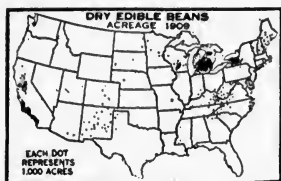

FIG. 182.—Where beans are grown.

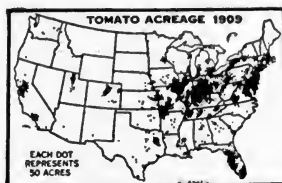

FIG. 183.—Tomato acreage.

or potatoes by late beans or corn; early beans may be followed by cabbage or lettuce, etc. Whenever it is not practicable to plant another vegetable, the land should be planted to some green-manuring crop.



FIG. 184.—Cabbages are grown generally.



FIG. 185.—Where onions are produced.

Rotation of crops is as important in growing vegetables as in growing field crops, and the same principles concerning rotation should be applied. In general, legumes such as beans and peas should be followed by root crops like beets, carrots, etc. Crops



FIG. 186.—Where watermelons grow.

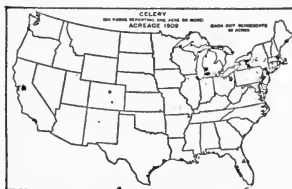

FIG. 187.—Celery acreage.

of the mustard family (cabbage, turnips, radish, etc.) should not follow one another. It is usually advisable to grow foliage crops like cabbage, kale and spinach after root crops (potatoes, beets, parsnips, carrots, etc.) or after those grown for fruit (tomatoes, peppers, melons, etc.). (Figs. 182, 183, 184, 185, 186 and 187).

**Local Rotations.**—Through members of the class make a survey of a number of farms and determine just what rotations are practiced. Study each as to the problems of soil maintenance, weeds, insects, diseases, tillage, income, etc.

**Rotation projects** may be started to solve one or several of these problems. Select the problems of economic importance in the region, and conduct such rotation of crops as to help solve the most difficult problems.

### QUESTIONS

1. What is meant by crop rotation? Illustrate.
2. Distinguish between "fixed" and "definite" rotations. Illustrate. Which of these is the more common? Why?
3. What is meant by "one crop system"?
4. What is the prime object of crop rotation? How is this brought about?
5. Explain how crop rotation may control certain insects and plant diseases. Give illustrations.
6. How may crop rotation affect the supply of soil organic matter?
7. Tell how a good rotation affects tilth. Illustrate.
8. Discuss rotation in relation to the conservation of fertilizing elements.
9. In what way may rotation be advantageous in liming and in fertilization?
10. In what way is rotation an aid in weed control?
11. Discuss the effect of a good rotation on soil fertility. (a) As a factor in maintaining fertility. (b) As a factor in increasing fertility.
12. Can crop rotation in itself maintain fertility or take the place of fertilizers? Explain.
13. What are the factors to be considered in maintaining soil fertility?
14. Are the beneficial effects of rotation due simply to a change of crops?
15. Name and discuss the factors determining a good rotation.
16. Tell of the importance of a good rotation in soil improvement. In this respect, what are the advantages of a short rotation? What important factor should be considered in planning a rotation for soil improvement?
17. Name in the order of their importance the crops grown in your state, and give some practical rotations in which these crops may be grown.
18. Name the states which lead in the growing of the following crops—corn, cotton, winter wheat, late potatoes, spring oats, spring wheat, sugar beets, tobacco, alfalfa and green peas.
19. What are some of the points to bear in mind in planning rotations for truck farming and vegetable growing?
20. For an outline summary of this chapter see table of contents.

## CHAPTER XVI

### SOIL EROSION

**Soil Erosion a Serious Problem.**—Soil erosion is commonly understood to mean the washing away of soil by water. On comparatively level areas this problem is not of much importance. In general, however, it has become most serious. Hundreds of thousands of acres of farm lands in the United States have rolling topography, and because of neglect in proper management, immense soil losses have occurred through hillside washing in every state of the Union and in almost every county of every state. It has been estimated that in the United States 4,000,000 acres of farm lands have already been ruined by soil erosion, and nearly twice as much more greatly damaged. This loss in terms of dollars amounts to millions annually.

**Injuries Resulting From Erosion.**—Land ruin is the most serious effect of soil erosion. Other injuries are: Much of the soil reserve of plant-food elements is washed away; much damage is done to irrigation; water power is lost; it interferes with navigation; and it interferes in farm management (Fig. 188).

*The loss of plant-food elements* caused by erosion is due to the removal of organic matter and the fine soil particles. This is clearly shown in the following analyses of two soils collected on the same farm—one sample was collected from the hilltop and the other from the cropped flat, or “creek bottom,” below.

	Organic Matter	Nitrogen per cent.	Phosphorus per cent.
Soil from hilltop.....	Low	0.12	0.04
Soil from creek bottom....	High	0.25	0.08

These data show clearly that the soil removed by erosion is the richest part of the land. This makes the erosion problem all the more serious. Indeed, it has been estimated that every year there is in the United States an unnecessary waste from soil erosion of more than 400,000,000 tons of soil material—an amount greater than that removed in digging the Panama Canal.<sup>1</sup> Much of this

<sup>1</sup> United States Department of Agriculture Yearbook, 1916.

comes from good farming lands. This means a reduction of the productive power of the country.

*Effects on Irrigation.*—Soil erosion is one of the serious dangers that threaten irrigation, as follows: When the blanket of soil is removed from the mountain sides, there is removed that natural reservoir which protects the headwaters of the streams. Because of large amounts of soil brought down by the streams, artificial reservoirs are filled up. Furthermore, water carrying sediment decreases the efficiency and increases the cost of maintaining

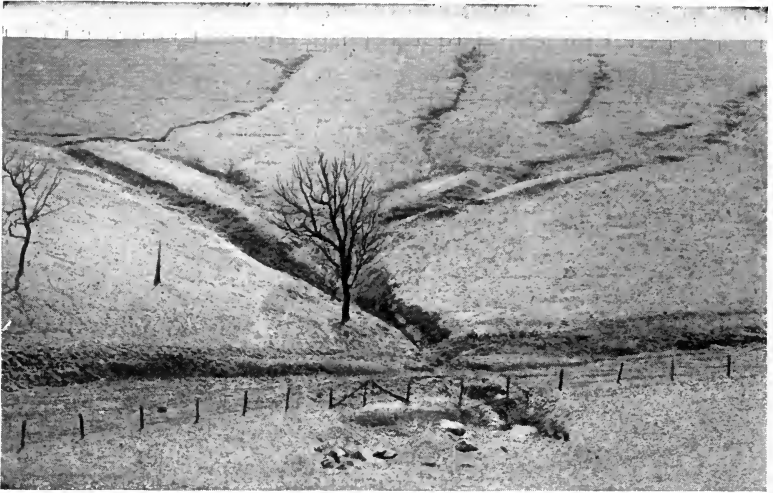

FIG. 188.—Soil erosion damages fertile fields. (Wisconsin Station.)

diversion dams, pipe lines, flumes, and canals. When irrigation water carries very much mud it injures the crops to which it is applied.

*Effect on Water Power.*—Erosion causes a loss of water power in two ways—the blanket of soil is removed from mountain sides, thus destroying the natural reservoir for water; and artificial reservoirs are filled up. In this manner soil erosion interferes with the steady flow of water so essential in developing successful water power.

*Erosion greatly interferes with navigation*, especially on the inland waterways of the country. In fact, it is largely because of the bad effects produced by erosion that these waterways have

not been properly developed. Many rivers formerly navigable have now become so filled with sediment that they cannot carry boats of even moderate size. Other rivers have to be dredged constantly to permit of navigation.

*Injures Crop Production.*—In crop production, ditches are very often the cause of greater machinery cost and repairs. Moreover, a crop cannot be cared for and harvested most efficiently when the field is full of ditches, nor can the land be prepared for planting at as low a cost as when no ditches are present.

#### CAUSES OF EROSION

**Nature's vs. Man's Way.**—It is the natural tendency for the soil to creep down slopes or to be washed away. However, when the ground is covered with leaf mold, grass, or other vegetation, the creeping is comparatively slow. During rains, especially in forests, the water is intercepted by the trees and drips down quietly without causing any beating effect on the soil. Moreover, the layer of leaf mold in the forest, grass in the open, and the organic matter in the soil permit the rain to soak gradually into the ground and not wash over it. In this way a steady source of water is provided the springs and streams. This accounts for the clear, steady streams which come from virgin forests; and it also explains why the pioneer farmers found so many more springs which flowed the year round than may be found today.

The development of our lands for agriculture marks the beginning of excessive erosion in this country. It was quite necessary, to be sure, that the primeval forests over the greater portion of the country should be cleared away to give place for corn and grain, but in the doing of it, it was entirely possible to greatly lessen and even prevent the excessive damage done to the soil. It has been largely because of man's activities, therefore—activities which were carried on with but little or no thought to the future—that this problem of soil erosion is so serious today.

**Clearing of Steep Slopes.**—The clearing of non-agricultural lands is one of the main causes of unnecessary erosion. Thousands of acres on slopes too steep for successful farming should never have been cleared, but because they were cleared, thousands of acres have become ruined. Such cleared lands have been cheap. Settlers moved on to them, and moved off again after they hastened devastation by improper methods of farming. Many lands should have been only partially cleared.

**Fire a Causal Agent.**—The effect of fire in its relation to soil erosion is similar to that of clearing. Fires have burned not only the tree growth but the leaf mold as well, leaving the ground exposed to the beating of the rains and thus causing surface run-off and hence soil washing.

**Destructive Lumbering.**—Clear cutting of timbered lands has commonly been practiced even on steep slopes where a part of the younger growth, at least, should have been allowed to stand. Fires have been permitted to do much damage, especially on cut-over areas. Roads were so laid out as to result in serious erosion and skid tracks were gouged out and left unprotected only to wash out after every heavy rain.

**Overgrazing.**—A hillside well grassed is fully protected from soil washing. During ordinary rains the grass protects the soil from the beating effect of the falling water, and also causes the water to soak into the soil and not pass away as surface run-off. The physical condition of the soil commonly present under a good grass covering has much to do in facilitating the entrance of the rain water into the ground. During heavy rains the long grass blades form a protective mat over which the flood waters pass with little or no harm to the soil underneath. When rolling lands are pastured or grazed too severely this protective grass covering is destroyed and severe erosion results.

#### KINDS OF EROSION

**Gully erosion** is characterized by the formation of V-shaped cuts or ditches. Sometimes these gullies are small, numerous and more or less parallel to each other. At other times they are few in number, but deep and broad. Under certain conditions gullies form which have vertical, cliff-like sides which keep caving in as the water undermines them. When once started, such gullies rapidly become deeper, wider and longer with every storm until they develop into ugly chasms.

**Sheet erosion** is the washing away of the soil more or less uniformly over the entire surface without the formation of gullies. This erosion usually forms on fields of only moderate slope. Every rain washes away some of the finer particles; but since the process of washing is usually slow, results are not particularly noticeable.

**Landslides.**—A landslide is the sliding down of a large quantity of soil. They are usually caused by the soil becoming saturated with water and then slipping in a large body from the under-



lying subsoil or rock. Frost action is also responsible for many landslides.

**River-bottom Erosion.**—Good valley land is often destroyed, either by the wearing away of the river banks along the main channel or by the gouging out of new channels. The Kansas River flood, of 1903, for example, completely destroyed 10,000 acres of excellent farming land and caused a total loss of at least \$22,000,000.

#### PREVENTION OF EROSION

**Prevention in General.**—Since surface run-off is primarily the cause of soil erosion, its prevention and control depend, in a large measure, upon the way in which the protective cover of trees, grass and other vegetation is cared for, and on the way in which cleared and cultivated lands are handled. There are, of course, some factors influencing surface run-off that are beyond the control of man, such as the distribution of the rainfall and the geological formation. Other factors, like the slope and the character of the soil, may be modified to a certain extent.

Much can be done to decrease and prevent erosion by preventing fires from sweeping through forests and over cut-over lands, by ceasing to overgraze the ranges, and by ceasing to clear steep slopes for farming. Since so many lands devoted to agriculture are rolling, erosion becomes a common agricultural problem. The following discussion concerns the control of erosion in farming.

**Drainage and Organic Matter.**—Surface run-off may be lessened by good underdrainage. In this way the capacity of a soil for taking in water is increased. Often the thorough drainage of a large body of peat greatly lessens the amount of flood water that will flow away because the greater portion, if not all, of the rainfall would be absorbed by the soil.

When the organic matter of any heavy soil is increased the soil becomes more open and crummy in structure, thus increasing its water-absorbing capacity. This also results in decreasing the surface run-off.

**Tillage.**—Plowing loosens the soil and this allows the rain water to soak more readily into the ground. In this manner deep hillside plowing of a heavy soil especially lessens erosion to a considerable extent.

When a hillside is plowed, it should be done at right angles to the slope; and all cultivated crops should be planted so that

cultivation can be done around or across the slope rather than with the slope. When furrows run up and down the hill washing is greatly increased. This precaution may well be observed in sowing grains as well.

**Crops May be Alternated on Hillides.**—On long slopes it is good practice to lay out the field into comparatively long and narrow strips, and crop them alternately with corn, grain and grass. In this manner the distance down hill through which the accumulation of water may occur is shortened, thus greatly preventing the formation of tiny streams.



FIG. 189.—Depressions through fields which serve as surface runs should be kept sodded. (Iowa Station.)

**Grassing and Cover Crops.**—On many steep slopes it is well to keep the ground well protected by a good grass cover. Depressions which serve as surface-runs should be kept sodded. The growing of winter cover crops like rye and clover should be encouraged. The roots of such crops help to bind the soil and the vegetative growth protects it (Fig. 189).

**Terracing.**—Terracing is the most effective method of preventing soil washing, and it is doubly effective when other methods of controlling erosion are practiced in connection with it. Terracing consists primarily in reducing the slope over which the water moves, or in stopping the flow of water down the slope by forming balks or breaks which gradually rise into banks separated by belts of plowland.

There are two distinct types of terraces—the bench terrace and the ridge terrace (Figs. 190 and 191). A field of bench terraces resembles a series of benches, while ridge terraces are simply

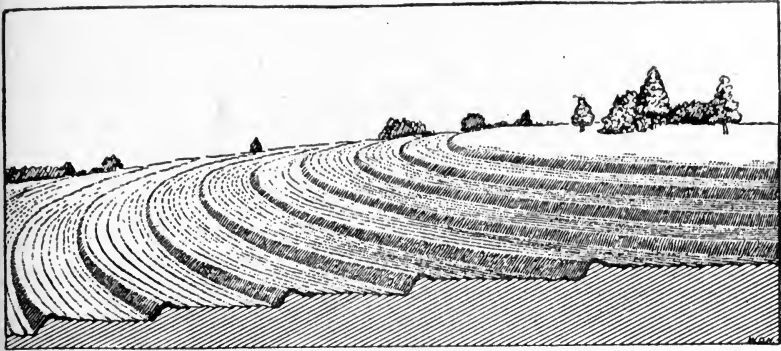

FIG. 190.—Bench terraces. (U. S. D. A.)

ridges of earth thrown up across the slope of a hillside. The former is essentially steep-land terracing, and the latter is for moderate slopes.

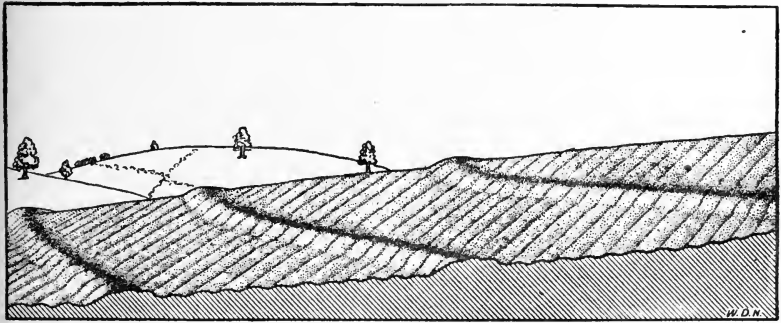

FIG. 191.—Ridge terraces. (U. S. D. A.)

In starting bench terraces it is best to locate the position of the balks on contour lines at regular intervals, and begin by throwing a furrow upslope and another downward. The balks thus started should be seeded to grass and kept sodded or planted to shrubs. The subsequent plowing on each belt of plowland should be with a reversible hillside plow, throwing the earth downward. The crop rows, too, should run on the contour lines. In time the balks will become steeply sloping banks fixed by the

strength of the sod or the hold of the bushes that may be planted on the balks, while the belts of plowland become level, or the slope of the benches is slightly reversed. When the benches become level, it is necessary to maintain only small shoulders about one-half a foot high at their outer edges.

Bench terraces should have no fall along the direction of their length. The level of the benches may be maintained or their slope regulated by plowing—by turning the furrow slices inward or outward as conditions may require.

In ridge terracing, the ridges are often cropped, or the field is planted and cultivated as if no ridges were present. In either bench or ridge terracing, the rain water that falls on a belt of plowland is collected and held above the lower terrace until it evaporates, sinks into the soil or finds its way slowly to an outlet at the ends of the terraces.<sup>2</sup>

Terracing is most commonly practiced in the Southern states.

#### STOPPING WASHING AND RECLAIMING ERODED LANDS

In stopping washes and in reclaiming eroded lands, it is necessary to make use of all the methods employed in prevention. Aside from these there are many other methods employed in stopping the advance of ditches and in filling gullies.

**Reforestation.**—Most frequently lands which cannot be used for farming because of excessive erosion must be reforested in order to be reclaimed. Trees should be planted thickly in the mouths of, and as far up, the gullies as possible.

**Other Measures.**—Straw or similar material is usually of much help in stopping or filling small gullies. Sometimes washes may be stopped by dragging in some dirt and sowing sorghum thickly. Often ditches may be filled with straw and *débris*, and dirt plowed in on top and seeded with grass, sorghum or grass. Brush, logs, stumps and stones are excellent materials to throw into gullies (Fig. 192). Such material should be well anchored to prevent its being carried away. Many ditches have been completely filled in this manner. Sometimes dams of wire, mesh, boards, brush and reinforced concrete are quite satisfactory for certain locations in preventing further erosion, or in reclamation. Usually such dams will gradually allow the gully above to fill with sediment (Figs. 192 and 193). The planting of willows or bushes along the edges of a gully is often effective in stopping further erosion.

---

<sup>2</sup> United States Farmers' Bulletin 997.



FIG. 192.—A stone dam is effective in filling gullies. (Iowa Station.)



FIG. 193.—Filling a bad gully by means of dams. (Iowa Station.)

**Field Study.**—Observe injury due to soil by erosion. Suggest prevention in particular cases.

**Projects in reclaiming eroded land** should be conducted. These may include any or all of the methods suggested in the study of this chapter.

Other projects in preventing erosion should include terracing, grassing, etc.

### QUESTIONS

1. To what extent is soil erosion a serious problem?
2. Discuss the injuries resulting from soil erosion.
3. Under natural conditions how is soil washing checked or prevented?
4. Explain why the streams from virgin forests are clear and steady.
5. What marks the beginning of excessive erosion in this country?
6. Discuss the clearing of steep slopes in relation to soil erosion.
7. Discuss the results of destructive lumbering and overgrazing.
8. Distinguish between gully and sheet erosion.
9. What are landslides? What causes them?
10. Describe river-bottom erosion.
11. Upon what depends, in a large measure, the prevention and control of soil erosion? Name other factors involved.
12. Discuss drainage and soil organic matter in relation to the control of erosion in farming.
13. What constitutes proper tillage and cropping on slopes subject to washing?
14. What is terracing as applied to soil management?
15. What are the two important methods of terracing? Describe each.
16. Mention some ways in which gullying may be stopped and eroded lands reclaimed.
17. What examples have you seen?

## CHAPTER XVII

### THE MANAGEMENT OF MARSH LANDS

IN the preceding chapters are discussed the fundamental principles governing soil management. Soils that are naturally productive, particularly loams and silt loams, are not difficult to manage. Their fertility may be easily maintained if due consideration be given proper tillage, crop rotation, and the use of lime, manure and special fertilizers. Some soils, however, differ so widely in their characteristics from ordinary soils that their improvement and management require special attention. These include marsh and swamp soils, sands, clays and depleted silt loams. In this and the following two chapters, these soils are discussed as regards their characteristics, improvement and the maintenance of their fertility.

**Three Kinds of Marsh and Swamp Soils.**—In general, there are three kinds of marsh and swamp soils, as follows:

- |   |  |
|---|--|
| 1. Peat Soils.....  | (a) May be shallow (6 to 18 inches), or deep (10 to 20 feet) |
|   | (b) May be overlaid by various materials                     |
|   | (c) May be <i>raw</i> or well decomposed                     |
|   | (d) May be reddish brown to black in color                   |
|   | (e) May be acid or non-acid                                  |
| 2. Muck Soils.....  | (a) May be overlaid by various materials                     |
|   | (b) They are heavier than peat soils                         |
|   | (c) May be acid or non-acid                                  |
| 3. <i>Marsh Border</i> Soils<br>(grades into and<br>borders the higher<br>land) | (a) May differ widely in texture                             |
|   | (b) Usually shallow and black in color                       |
|   | (c) Usually have a blue or mottled clay or sand<br>subsoil   |
|   | (d) May be acid or non-acid                                  |

Peat and muck are special types of soils. The "marsh border" soils grade into muck or peat on the one hand and upland on the other. With the marsh border soils are also grouped the poorly drained, dark colored soils found along streams and in depressions on upland. The marsh border soils include many types. In limestone sections they are named Clyde silt loam, Clyde sandy loam, etc. In sandstone sections they are called Dunning sand, Dunning clay loam, etc. In sections in which the country rocks are granitic they are designated as Whitman sandy loam, Whitman loam, etc. When well drained these soils are usually highly productive.

**Advantages in Farming Peat and Muck Soils.**—Well-drained

peat and muck soils can be made productive and profitable. In fact, there are certain advantages in farming such lands, as: (a) They are especially well adapted to highly intensive types of farming such as truck growing and market gardening; (b) they are easily worked; (c) they respond quickly to proper fertilization, and (d) they usually supply crops with sufficient moisture during dry periods.

**Most Desirable Muck and Peat.**—Muck lands are, as a rule, more desirable to reclaim than peat. Of the peats, those that are shallow, well-decomposed and underlaid by clay or silty clay are the most desirable. Those that are "raw," coarse and deep, or raw and underlaid by coarse sand, on the other hand, are the least desirable.

**Problems in Peat and Muck Management.**—In developing and farming peat and muck lands a number of problems must receive careful consideration. These problems should be kept well in mind, together with the manner in which they should be solved. These are summarized in the following table:

*Problems in Peat and Muck Management and Their Solutions*

Problems	Solutions
Excessive moisture	Thorough drainage
Excessive grass, moss or brush	Burn (do not burn the peat)
Breaking when tough turf exists	Use heavy 18" or 24"-bottom tractor plows.
Deficient in potassium and phosphorus	Use potash and phosphate fertilizers
May lack nitrifying organisms	Apply manure
If strongly acid	Lime the land
Too loose seed bed	Compact through the use of rollers
Subject to late spring and early fall frosts*	Select proper crops and varieties; fertilize properly

\* On marshes in the Northern states. See Chapter IX.

**Drainage.**—It is useless to attempt the growing of crops on marsh lands without adequate underdrainage. Open ditches alone often provide just enough drainage to encourage the farmer to plow and plant, but do not provide the thorough drainage necessary to ensure the crops. Tile in peat should be laid deep to permit of deep drainage and to allow for the shrinkage and the settling of the soil. The lines of tile should be given sufficient fall to permit them to carry off the water. All springs or water-bearing substrata should be located and tapped with lines of tile. The marsh zone bordering the high land should be especially well drained, since this is often the wettest portion of the marsh.



**Clearing and Breaking.**—When peat and muck lands are covered with tree growth, the problem of clearing and removing the stumps is comparatively simple, since the stumps are usually shallow rooted and the soil is light and loose.<sup>1</sup> The cost of clearing varies from fifteen to thirty dollars per acre, and sometimes as high as seventy-five to one hundred dollars per acre.

Rank grass, sphagnum moss and brush can best be eliminated through burning. The most desirable time to accomplish this is



FIG. 194.—Two twenty-four-inch bottom plows turning tough marsh turf. (Wisconsin Station.)

when the rubbish is dry but the soil wet. This is usually done during late spring and early summer. Peat should never be allowed to burn except when there is a surface layer of loose, spongy, raw peat. In such a case conditions should be controlled to prevent the burning of the lower stratum. Should peat soil catch fire, the best method of putting it out, unless soaking rains come, is to dig an open trench around the fire down to moist or wet earth and let it burn itself out.

Wild turf on marshes is usually very tough and difficult to break. The use of heavy, wide-bottomed breaking plows gives best results

<sup>1</sup> When peat and muck lands supporting tree growth are drained by good open ditches, the trees soon die. It is desirable to leave the open ditches three to four years to allow for the settling of the peat. The ditches are then cleaned out and the tile laid. During the settling period the trees may be cut and the stumps pulled.

(Fig. 194). Summer and early fall breaking is advisable. Subsequent plowing may be done by the use of the ordinary plow.



FIG. 195.—“Sticking” corn immediately after burning. Soil about eighty per cent organic matter. (North Carolina.)



FIG. 196.—“Stuck” corn on burned-over land. (North Carolina.)

Some peat and muck lands, as in eastern Carolinas, are covered with a thick growth of brush and trees which fill the soil so full of tough roots and stumps that breaking is exceedingly difficult or impossible. In such cases the brush is cut and burned and corn planted without any attempt at breaking (Fig. 195 and 196).

During this initial cropping the roots rot, thus permitting subsequent clearing and cultivation.

Frequently marsh lands become very boggy largely as a result of pasturing while the land is still too wet to cultivate. These bogs add to the difficulties of breaking. When they are cut off and cut to pieces, breaking is much facilitated (Fig. 197).

**Preparing the Breaking for Planting.**—Tough, turf breakings should be thoroughly harrowed. A cutaway-disk harrow is an excellent machine to use (Fig. 90). The use of a tractor in pre-



FIG. 197.—A bog cutter. Note the cutting blade (A) extending from runner to runner.

paring the new seed bed is especially good, because its weight firms the soil and presses the furrow slices down so that good contact is made with the subsoil.

**Fertilizer Needs.**—Chemical analyses show that peat and muck soils, in general, contain comparatively small amounts of potassium and phosphorus. Furthermore, experience and field tests have clearly demonstrated that potash and phosphate fertilizers and manure are second in importance to thorough drainage in determining crop production on these soils.

Peat and muck<sup>1</sup> soils vary in their fertilizer needs. Some will produce fair to good crops for a year or two, after which the yields diminish rapidly unless the land is fertilized. Other marsh soils are so deficient in potassium that they fail entirely to produce

crops such as corn, even the first year, without manure or fertilizers. Potash fertilizers give the greatest returns on most marshes, particularly those not strongly acid (Fig. 198). Soils showing an apparent need of potash fertilizers only, eventually need phosphates, particularly those on which no manure is used. Acid marshes usually require both potash and phosphate fertilizers, the potash being often a secondary need. Frequently a phosphate

FIG. 192.

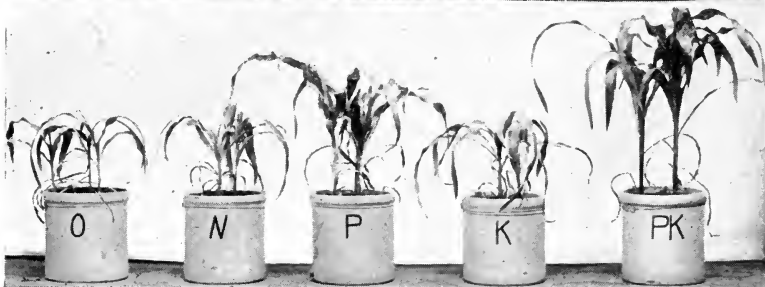
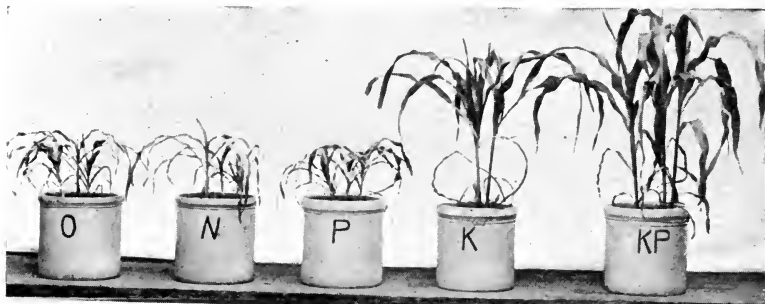

FIG. 193.

FIG. 198.—This peat soil responds particularly to potash treatment. *O*, no treatment; *N*, nitrogen; *P*, phosphate; *K*, potash; *KP*, potash and phosphate.

FIG. 199.—This peat soil responded readily to phosphate fertilizer, but best to phosphate and potash. *O*, no treatment; *N*, nitrogen; *P*, phosphate; *K*, potash; *PK*, mixture of phosphate and potash fertilizers.

fertilizer, when used alone, gives no increase in yield, but when used in conjunction with a potash fertilizer it increases the yield as compared to that secured from the use of potash alone (Fig. 199).

Frequently muck or peat underlaid by silty clay, or clay at a depth of about twelve or fifteen inches, shows a marked need of potash fertilizer for a few years, but after that this need of potash partially or entirely disappears. This is because the settling of the

soil causes considerable of the subsoil, which contains an abundance of mineral elements, to become mixed with the soil through plowing and harrowing.

Nitrogen is present in all muck and peat soils in abundance. For intensive crops like onions, cabbage and celery, fertilizers containing nitrogen seem to be profitable, especially on new lands.

**Choice of Potash and Phosphates; Their Application.**—Muriate of potash is most commonly used. Sulfate of potash, a higher-priced material, is thought by some to produce better quality in crops like potatoes and onions, but this claim has not been verified. On soils not previously fertilized, the usual application of muriate or sulfate of potash consists of about 100 pounds per acre for grass and small grains, 250 to 300 pounds per acre for corn and potatoes, and about 400 pounds per acre for sugar beets, onions, etc. When grown in rotation, the hay is not fertilized since it receives the residual effect of previous applications.

Of the phosphate fertilizers, acid phosphate is most commonly used. On soils requiring phosphorus as a secondary need, initial applications may be made at the rate of 200 pounds per acre for small grains, and 400 to 600 per acre for corn and truck crops, respectively. Soils especially in need of phosphorus should be given special phosphate treatments.

These fertilizers may be mixed and applied at any time. For general soil improvement broadcast application is recommended. It is best to mix the fertilizers with the soil through harrowing. Subsequent applications may be made in somewhat less amounts, especially when manure is used.

It is more economical to buy muriate of potash and acid phosphate separately and mix them on the farm. A desirable mixture for general use is obtained when these two fertilizers are mixed in equal proportions.

Rock phosphate applied directly to muck and peat and thoroughly mixed in the soil sometimes gives excellent results (Fig. 200).

Large amounts of mixed commercial fertilizers are used on marsh lands. Applications vary from 200 to 300 pounds or more per acre for crops like grain, and 500 to 1500 pounds or more per acre for corn and truck crops, respectively.

On lands previously cropped and fertilized, the application of commercial fertilizers in the hill or drill for crops like corn gives excellent results, especially when a mixture of muriate of potash

and acid phosphate is used. In a six-year test on a peat marsh in Wisconsin<sup>2</sup> an annual application of 125 pounds of a mixture of muriate of potash and acid phosphate, mixed in equal proportions, and applied in the drill for corn gave better average results than the use of a mixture of 400 pounds of muriate of potash and 600 pounds of acid phosphate applied once in the first three-year period of the experiment, and 200 pounds of each of the two fertilizers applied once in the second three-year period.

The favorable results secured in applying fertilizers in the drill through the use of fertilizer attachments have led many truck



FIG. 200.—Rock phosphate prevented lodging of oats on this peat (1918). To right, 1000 pounds rock phosphate and 200 pounds potash applied per acre in 1913. To left, 200 pounds potash and 400 pounds acid phosphate applied per acre (1913).

growers on marsh lands to make a liberal application of fertilizer broadcast (either manure or commercial fertilizers) and to follow with an application of about 132 pounds of a complete fertilizer in the drill, especially for crops like the sugar beet and cabbage.

**Manure on marsh lands** may give good results. Many growers prefer manure to commercial fertilizers for truck crops. For general crops like corn and grains, commercial fertilizers are much more economical (Fig. 132). When manure is not plentiful its application to upland soils is preferable and more profitable. If, on the other hand, manure is plentiful and the uplands have all

<sup>2</sup> Peat is well decomposed, averages five feet deep and is thoroughly drained. Received manure treatment the year before the test began. Corn was grown each year.

been heavily manured, its application on peat or muck may be advisable. Some truck growers have found potash fertilizers to be quite necessary to reinforce the manure.

The use of manure greatly increases the weed problem. In case of corn, weed control can be much facilitated when the crop is planted in checked rows to permit of more thorough cultivation. Because of the weed problem, many farmers much prefer the use of commercial fertilizers entirely, especially for general farm crops.

**Wood Ashes Are Valuable.**—Unleached wood ashes applied at the rate of from one to two tons<sup>3</sup> to the acre give most excellent results on acid mucks and peats, chiefly because of the potash and carbonate of lime they contain. Results secured through the use of wood ashes on some acid peats could not be duplicated by any mixture of commercial fertilizers.

**Liming and the Nitrogen Problem.**—Even though peat and muck soils contain nitrogen in abundance, some crops growing on these soils suffer for want of this element. It may be advisable at times to apply nitrogen in the form of nitrate of soda as a top-dressing at the rate of 50 to 100 pounds to the acre to a crop like onions, when it shows the need of it by turning yellow. This perhaps explains why mixed fertilizers and manure are much preferred by truck growers.

A nitrogen deficiency may occur as a result of four conditions, viz.: (a) The soil may be too cold to favor decay and nitrification; (b) decomposition may be too slow because of the nature of the organic matter; (c) strong acidity may hinder the formation of available nitrogen; (d) there may be a lack of nitrifying organisms (Chapter XI).

Nitrification in strongly acid soils is greatly promoted through liming. Finely pulverized limestone or any other finely divided lime may be used. The use of agricultural lime is particularly necessary in fitting acid peats or mucks for truck growing. The addition of lime not only favors nitrification, but it renders the phosphorus more available as well (Chapter XIII).

It is thought that the particularly beneficial effect of manure on many marsh soils is due in part to helpful organisms which are added with the manure. Horse manure is especially good in this respect. Peat lands which are pastured a few years before breaking are much improved both in their physical condition and in their productive power.

---

<sup>3</sup> When containing 30 to 40 per cent moisture.

**Unproductive or "Bogus" Spots.**—It is common experience in marsh-land development to find some spots that are difficult to make productive. These may be alkali spots (p. 44); small areas lacking adequate, subsurface drainage; the soil may be exceptionally deficient in potassium; or they may be unproductive because of the presence of some poisonous compounds. If given special attention, these conditions can usually be corrected through proper drainage and through the use of mineral fertilizers and agricultural lime.

**The Roller Necessary in Marsh-Land Farming.**—Much difficulty is experienced in farming peat lands because the soil is so loose. In order to secure a firm seed bed, it is necessary to use a roller. Often it is best to roll a field several times. Rolling both before and after seeding or planting is preferable. Sometimes desired results can be attained only when the roller is heavily weighted, or when an extra heavy roller weighing from 3000 to 5000 pounds is used. Smooth rollers are not so satisfactory as other forms of packers. The use of a tractor in preparing the seed bed is beneficial in this respect. A firm seed bed warms up better, and this reduces the danger from frosts.

Hay fields on muck and peat lands may be much benefited if they are rolled in the spring.

**Frost on Marsh Lands.**—One of the disadvantages in farming northern marsh lands is the danger of frosts. On account of later frosts in the spring and earlier frosts in the fall, the growing season on such lands is considerably shorter than on the high land in the same locality. This emphasizes the necessity of considering carefully the crops to be grown on the marsh lands in any particular section. For the more northern marshes root crops, hay, cabbage, grains and early varieties of corn are recommended.

When frosts occur either in early or late summer, the injury to corn is much reduced if the crop is well fertilized. This advances the corn and seems to enable it to withstand the low temperature much better than it otherwise could. Applying fertilizer in the drill is advantageous in this respect (Figs. 201 and 202).

**What Crops Best to Grow.**—The fact that mucks and well decomposed peats are most excellent soils for trucking and gardening has led many marsh-land owners to think that these soils are adapted for intensive crops only. According to the United States Department of Agriculture, at least 300,000 acres of marsh lands





FIG. 201.—Corn on peat properly fertilized was not entirely destroyed by frost. (See Fig. 202.)



FIG. 202.—Corn not fertilized was completely destroyed by frost. Plot about four rods from that shown in Figure 201.

could produce all the cabbage, onions, celery and mint needed by the whole United States.<sup>3</sup> In the eight North Central States<sup>4</sup> alone there are 15,000,000 acres of marsh and swamp lands most of which are capable of being drained and utilized for agricultural purposes. It is plain, therefore, that all marsh and swamp lands cannot possibly be utilized for trucking and gardening, but may be suitably used in growing general farm crops (Fig. 203).

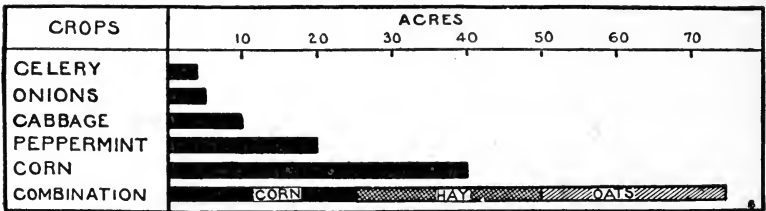

FIG. 203.—Approximate number of acres on peat land that can be worked by one man in different crops. (U. S. D. A.)

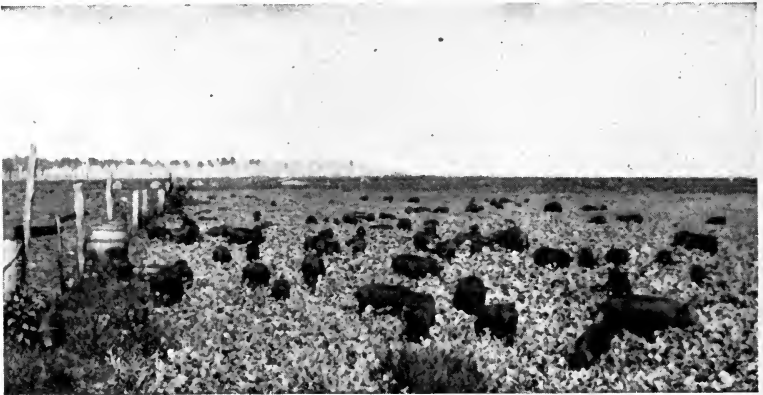

FIG. 204.—Farming marsh lands along extensive lines. Four years from swamp. Hogs in rape. (North Carolina.)

On tough turf breakings buckwheat and flax are commonly grown to subdue the sod. On pastured marshes, particularly, corn is frequently grown as the first crop. Crops for marsh lands are mentioned in the table on next page, together with the advantages and disadvantages in growing them.

<sup>3</sup> United States Department of Agriculture Farmers' Bulletin 761.

<sup>4</sup> Ohio, Indiana, Michigan, Illinois, Wisconsin, Minnesota, Iowa and Missouri.

*Crops for Marsh Lands\**

Crops	Advantages	Disadvantages
Corn	Good yield and prices; labor cost low	Danger of frost in late spring and early fall; weeds frequently troublesome
Hay	Yield good; price fair; labor cost very low	Quality of marsh hay sometimes poor
Pasture	Excellent pasturage; good returns; moisture supply good	Sometimes injured by excessive heaving during winter
Potatoes	Easy to plant, cultivate and harvest potatoes on muck and peat	Market discriminates against "muck" potatoes
Winter wheat	Good yield; price stable; labor cost low	Frequently heaves badly in winter; difficult to get firm seed bed
Barley	Usually as profitable as oats	Danger of frost in spring and lodging at harvest time
Oats	Yield and price fair; labor cost low; good feed	Danger of frost in spring; frequently lodges badly at harvest time
Rye	Good value as feed	Yield and prices usually low
Buckwheat and flax	Good to subdue tough sod; easy to grow	Danger of frost; subject to blight on marsh lands
Cabbage	Possibility of good income per acre	Fluctuation in price; danger of rotting; large labor requirements
Onions	High yield and possibility of very large income per acre	Great fluctuations in price; weeds difficult to control; large amount of labor required; insect enemies
Celery	Muck and well-decomposed peat soils best for celery; large income per acre	Large amount of labor required; danger of blight and rotting; price unstable
Sugar beets	Good yield and returns	Requires much labor; quality lower than upland beets
Peppermint	Muck and well-decomposed peat best for peppermint; possibility for very large income per acre with moderate amount of labor	Demand very limited; fluctuation in price great; expensive equipment needed
Hemp	Good income per acre	In some sections much skilled hand labor required because of lack of proper machinery
Millet	Grows well on marsh soils; can be sown late	Not the best of feed
Soybeans and Cowpeas	Grow well on muck and peat; high feeding value	Inoculation necessary; strongly acid soils should be limed
Alfalfa	Has been grown on well-drained muck and peat; excellent feeding value	Not a dependable crop; winter kills; requires thorough drainage, lime and inoculation

\* With special reference to marshes in the Northern states, as regards frost.

**Crop Rotation.**—Rotation, or at least a change of crops, on marsh soils is advisable (Chapter XV). Many farmers who specialize in growing onions, celery, cabbage, etc., much prefer to grow the same crop continuously on the same land. Little attention is thus given to minor crops; and when a change of crop is made, it is only when the principal crop is threatened with some insect or plant disease.

Some successful truck growers plan the growing of clover and timothy at frequent intervals. This adds easily decomposable organic matter (as sod), which aids the liberation of plant-food elements and improves the physical condition of the soil.

Some good rotations for general or dairy farming are as follows:

A.—Corn (three to four years). Oats or barley. Hay (clover and timothy).<sup>5</sup>

B.—Corn (two years). Oats. Hay. Pasture.

C.—1. Corn (rape sown at last cultivation). 2. Sugar beets.

3. Oats (seeded). 4. Hay (pasture may follow for fifth year).

Corn is often grown two to three years in succession. Some sow rape at the last cultivation. This is beneficial not only in furnishing some fall pasture (Fig. 204), but also in firming the soil. After the original wild sod is subdued, it is often advisable to grow corn or some other cultivated crop two or three years before grain is tried. Too thick seeding of grain should be avoided, because of the danger of lodging which necessarily smothers the seeding of clover and grass. For this reason it is often advisable to cut the first oat crop or two for hay to save the seeding. The prevention of lodging depends, in a large measure, on the amount of seed sown per acre and the use of proper fertilizers. A mixture of alsike clover, timothy and red-top constitutes the most common grass seeding for marsh lands. These are usually mixed in about equal proportions. Medium red clover is sometimes used.

**Types of Farming.**—Four types of farming may be practiced on marsh lands, viz., trucking, dairy or stock farming, grain farming, and combination farming, as trucking and dairying. The type of farming practiced in any locality depends upon many factors, important of which are: The adaptation of crops to soil and climate; nearness to markets; availability, cost and seasonal distribution of labor; and injury from insects and plant diseases.

Trucking is determined largely by the nearness to large centers

---

<sup>5</sup> Alsike clover, timothy and red-top is a common grass or hay mixture for marsh lands.

of population which offer ready markets. The lack of available labor in some sections, on dairy and stock farms, and especially on large tracts, determines, in a large measure, the development of marsh lands along extensive lines, since one man in general or stock farming can care for many acres. This is well shown in Figure 203.<sup>6</sup>

The growing of general farm crops does not involve so much risk as in the growing of such crops as onions and celery; moreover, the profits are more dependable from year to year. It is also highly probable that, through a period of years, the average profit in grain-and-stock farming will be larger than for any special type, as in celery or onion farming, when similar amounts of capital and labor are involved.<sup>6</sup>

Many farms include marsh tracts containing from a few to many acres. It is common experience that when these tracts are well drained and properly fertilized they become as profitable as the best upland.

It is possible to pursue general or stock farming on farms consisting entirely of muck and peat soils. Indeed, many such farms are already being operated with marked success. These are encouraging facts since it is plainly evident that if large areas of marsh lands are to be utilized for agricultural purposes extensive systems of farming must be developed.

**Field Studies.**—1. Study good systems of marsh management, particularly on successful farms.

2. Examine an undrained marsh and note in particular the wetter portions, and determine the reasons why.

3. On the same area examine the depth and different types of soil. Sketch a map of the area indicating the streams, types of soil, etc.

**Home Projects and Experiments.**—To determine the profitable use of mineral fertilizers on a peat soil.

*Procedure.*—Lay out at least an acre, or a smaller area, of peat soil and divide equally into three strips. To strip No. 1 apply muriate of potash at the rate of 200 pounds per acre. Strip No. 2 is to receive no treatment. On strip No. 3 apply a mixture of muriate of potash and acid phosphate at the rate of 200 pounds of the potash and 300 pounds of acid phosphate per acre. (Figs. 225, 226, 227, 132, and 221). Keep account of all costs, determine yields, and compute net profits.

**To Compare the Value of Wood Ashes with a Potash Fertilizer.**—*Procedure.*—In a similar manner as in the previous project, compare the value of wood ashes with muriate of potash or sulfate of potash. Use corn. Consult text.

**To Determine Economy in Using the Proper Fertilizer in the Hill for Corn.**—*Procedure.*—Mix acid phosphate and muriate of potash in proportion of one to one. On one strip of peat apply 125 to 135 pounds of this mixture per acre.

---

<sup>6</sup> United States Department of Agriculture Farmers' Bulletin 761.

for corn with a fertilizer attachment on the planter; on an adjoining area apply 400 pounds of the mixture, broadcast. Drag the fertilizer in before planting. Plant all the corn at the same time. Keep account of costs, determine yields and compute profits.

**Other projects and experiments** may be planned on suitable plots to compare, (a) spring plowing with fall plowing; (b) plowing under barnyard manure with the application of manure as a top dressing and disked in before planting; (c) plowing of peat with just disking; (d) the growth and yield of a crop on well-rolled plot with that on unrolled plot.

### QUESTIONS

1. Distinguish between marsh and swamp lands.
2. Describe in general marsh and swamp soils.
3. Can any good be said of muck and peat soils?
4. Tell of the relative value of muck and peat soils for farming.
5. What are the important problems in the development and farming of marsh and swamp lands? How may these problems be met?
6. What is a common mistake made by marsh-land owners?
7. Discuss in general the drainage of marsh and swamp lands.
8. Discuss the problem of clearing and breaking. In preparing the new seed bed.
9. What are the fertilizer needs of peat and muck soils? How have these needs been shown?
10. Does the same rule concerning specific fertilizer needs apply to all marsh and swamp soils? Explain.
11. What choice is to be made of the different fertilizers?
12. How may commercial fertilizers be applied to peats and mucks? Which method is the best?
13. Discuss the use of manure on peat and muck soils.
14. Where would unleached wood ashes give best results, on an acid peat or on a non-acid silt loam? Why?
15. Is it necessary to lime marsh lands?
16. How may manure benefit marsh lands other than through the addition of fertilizing elements?
17. What can be said of the benefits to be derived in pasturing peaty soils?
18. What may be the nature of unproductive spots on marsh lands? What remedies should be applied?
19. What important problem arises in farming peat lands due to the physical characteristics of the soil? Discuss remedies.
20. Discuss the relation of frost to marsh lands. What can the farmer do to avoid or lessen injury due to frosts?
21. Distinguish between intensive and extensive farming.
22. Are all marsh and swamp lands to be developed and farmed along intensive lines? What are the facts?
23. Name some advantages and disadvantages in growing the following crops on muck and peat soils: Corn, hay, potatoes, oats, hemp, cabbage, mint and sugar beets.
24. Is it necessary to practice crop rotation on marsh soils? Discuss.
25. What types of farming may be practiced on muck and peat soils? What are some of the factors determining the choice to be made?
26. Which type of farming assures greatest profits?
27. Upon what depends, in a large measure, the future development of large tracts of marsh lands?
28. If possible, describe a particular case of management of marsh land.
29. For an outline summary of this chapter, see table of contents.

## CHAPTER XVIII

### SANDS AND THEIR MANAGEMENT

SANDY soils include four important classes, namely: (1) Coarse and medium sand; (2) fine sand; (3) sandy loam, and (4) fine sandy loam. The last two classes are generally recognized as excellent soils, and their management requires no special attention when due consideration is given to the maintenance of their fertility. When depleted they require about the same treatment in their improvement as do loams and silt loams. The medium



FIG. 205.—Shifting or dune sand.

sands and the fine sands, on the other hand, have certain characteristics which necessitate a special knowledge for their successful management.

The fine sands are much more desirable soils than coarse sands. This fact is usually indicated by the character and size of the undergrowth of cut-over lands or by the original vegetation which they are supporting or have supported. Heavy growth and hardwoods usually indicate the presence of more fine material in the soil and a higher content of plant-food elements, which mean more favorable cropping possibilities.

Dune or shifting sands (Fig. 205), being of little or no agricultural value, are not considered in this chapter.

**Advantages in Farming Sands.**—There are several advantages to be considered in farming sands, namely: (a) They are warm and quick soils; (b) they are especially well adapted to the growing of small fruit, early vegetables and such crops as strawberries,

melons and pineapples; (c) they are easy to till; (d) they can be worked readily during wet seasons or when wet; (e) they respond quickly to proper fertilization; (f) they are profitable in proportion to their valuation.

**Sand Problems.**—The main problems encountered in cropping sands may be summarized as follows:

*Problems in Sand Management and How to Solve Them*

Problems	Solution
Low in nitrogen and organic matter	Apply manure; grow legumes
Soils usually acid	Lime the soil
Deficient in phosphorus and potassium	Apply mineral fertilizers
Too loose seed-bed	Roll the land; increase organic matter
Moisture supply uncertain	Conserve moisture; increase organic matter
Subject to wind-action	Wind-breaks; proper field management

**Nitrogen and Organic Matter.**—The need of nitrogen and organic matter is of the greatest importance in sand farming. For this reason, the growing of legumes such as soybeans, cowpeas, velvet beans,<sup>1</sup> mammoth clover, etc., should be given the greatest attention. Many times sands are so poor that winter rye is the only crop that can be grown. This rye should be plowed under in the spring, and soybeans, mammoth clover or some other suitable legume planted. The entire legume crop should be plowed under when still green. Following this a short rotation may be put into practice, not only to provide an income, but to improve the soil as well.

Increasing the organic matter and maintaining it constitutes a big problem. The whole program in sand farming should center on this problem. Agricultural lime, manure, commercial fertilizers, and green manure crops should be used particularly to increase the growth of clover and other legumes, these being necessary to assure good yields of other crops.

**Manure for Sands.**—Since sands are usually deficient in the three important plant-food elements, manure is an excellent fertilizer to use. When well decomposed, its application as a top-dressing on plowed ground into which it is disked seems to give best results for corn. It is advisable, however, to apply much of the manure as a top-dressing on the clover fields.

<sup>1</sup> Velvet beans and cowpeas are important legumes for soil improvement in the South.



Manure alone does not supply the full needs of sands. Phosphate and often potash fertilizers are necessary to develop properly balanced soils.



FIG. 206.—Sand without the wherewithal to produce. (See Fig. 207.)



FIG. 207.—From poor to productive sand in three years. Lime and proper fertilizers. Same soil as shown in Figure 206.

**Nitrogen Fertilizers.**—(See index.) The low supply of organic matter in these soils necessarily means a low nitrogen supply, hence the urgent need of nitrogen. However, the use of commercial nitrogen fertilizers, such as nitrate of soda and ammonium sulfate, as the main sources of nitrogen in general farming on sands is not recommended, since these fertilizers cannot take the place of

legumes and manure in supplying the much-needed organic matter (see index).

**Liming Sands.**—For most sands lime may be regarded as the second important need in their improvement. This is necessary, not only to supply available calcium for crop needs, but to render the fertilizing elements in the soil more available as well (Figs. 206 and 207).

Without sufficient lime alfalfa cannot be grown on acid sands. Mammoth, medium red, crimson and Japan clovers are much benefited when sands of slight to medium acidity are limed.



FIG. 208.—A good crop of soybeans on sandy soil.

Soybeans (Fig. 208), cowpeas, and velvet beans grow very well on sands having slight to medium acidity, but when the soils are strongly acid liming is necessary for best results (p. 229).

**Phosphorus and Potassium Needs.**—Some sands, especially those of slight to medium acidity, require phosphorus as second in importance to nitrogen and organic matter. On most sands, however, phosphate and potash fertilizers are indispensable; the potash being of most value during the first few years of improvement.

Of the phosphate fertilizers, acid phosphate and steamed bone meal are most commonly used. Best results in the use of these fertilizers are secured after the nitrogen and organic matter have increased, and acidity has been reduced by liming. Acid phosphate may be applied at the rate of 300 to 500 pounds to the acre, applied as a top-dressing and disked in. This application should be made to benefit the legume crop, and may be repeated at least once in a three-year rotation.

One hundred twenty-five pounds of muriate of potash should also be applied with the phosphate. Additional amounts of 50 to 100 pounds of the potash fertilizer may be applied per acre for corn and potatoes, respectively.

For more permanent soil improvement rock phosphate (see index) may be used instead of acid phosphate, but not until the soils have been well enriched with organic matter.

**Use of Mixed Fertilizers.**—Many have found it profitable, in addition to the use of manure and special fertilizers, to use from 125 to 200 pounds of mixed fertilizers per acre for corn, applied in the hill or drill and about 500 pounds for potatoes.

Usually, it is advisable, in the spring, to apply a light top-dressing of manure to the rye to increase the yield and especially to benefit the clover seeding. When manure is not available, an application of 400 to 500 pounds of a 2-8-1, or a 4-12-0 mixed fertilizer (NPK) may be substituted. A mixture of 100 pounds of dried blood and 300 pounds of acid phosphate per acre gives good results. The fertilizer should be mixed with the soil through disking or harrowing. Harrowing grain on sand in the spring does not injure the crop, but greatly improves it.

**The Seed Bed.**—Much care should be given to the preparation of the seed bed. Firmness is desired (see Tillage, in index). This can be accomplished through good plowing, thorough harrowing and by using a corrugated roller or cultipacker (p. 155). The importance of close contact between the soil and the seed (Fig. 21) and, later, between the soil and the young roots should always be kept in mind in preparing a seed bed on sand, and in planting and sowing. The presence of a good supply of organic matter is an important factor in preparing a proper seed bed.

**The Moisture Supply.**—The water-holding capacity of sands is low (see index). Moreover, this moisture is easily secured by crops and thus this comparatively small amount of moisture, if not replenished by rains, is soon used up. Crops on sand, therefore, frequently suffer for want of moisture during dry periods. To lessen this injury, moisture conservation and control should be given special attention. Soil mulching is important. Disking and "dragging" winter rye in the spring is good practice. Sowing such legumes as soybeans and cowpeas in rows to permit of cultivation is advisable. In case of potatoes, endeavor to grow thrifty vines to shade the ground. When the subsoil is sand, subsoiling or deep spring plowing should never be done.

The only way to increase the water-holding capacity of sand is to increase the organic matter (Chapter IX).

**“Blowing” of Sands.**—Because of the lack of sufficient material like clay and organic matter to bind the soil particles together, sands are loose and subject to wind-action. Often during the early growing period before the ground is covered by growing crops, high winds blow so much sand as to greatly injure and even destroy crops, especially corn and potatoes.

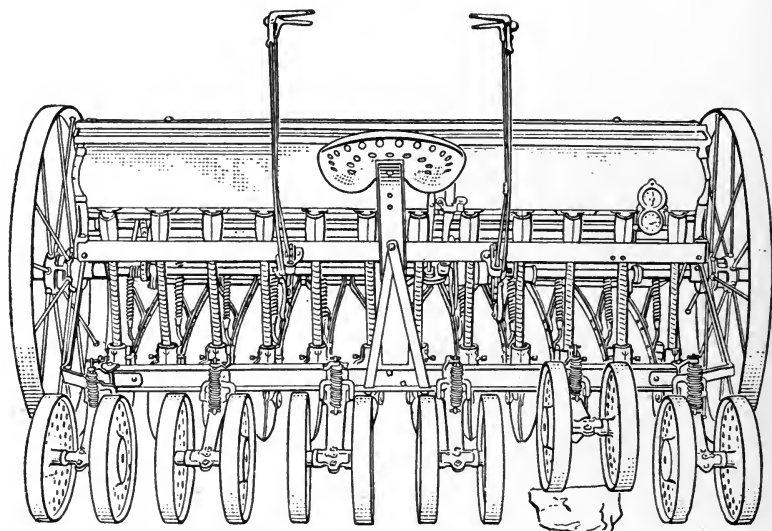

FIG. 209.—Press-wheel attachment for grain drill. Splendid to use on sandy soils. (Fig.98.)

Wind-breaks are means of protection to a limited extent. These may be planted, or when trees are cut in land-clearing, rows of trees or narrow strips of timber may be left for this purpose. A very effective way of protecting lands which are subject to wind-action consists in laying them out in long narrow strips at right angles, or nearly so, to the prevailing winds. These strips should be managed so as to have crops that cover the ground in the early spring, such as clover or rye, alternate with cultivated strips. Sands become less subject to “blowing” when, by proper management, they are enriched in organic matter.

Sand fields become much more exposed to wind-action when they are fall plowed. It is usually best, therefore, to plow exposed

sand fields in the spring. Fall cover-crops should be given much attention.

**Other Points on Management.**—In clearing sand lands, grass, leaves, etc., should never be burned, but plowed under whenever possible.

*Plowing.*—First plowing should never be more than four and one-half to five inches deep, and subsequent plowing not deeper than six inches. Spring plowed land should be made firm by harrowing and rolling. A weeder is a good implement for sandy soils (Fig. 210).



FIG. 210.—Riding weeder, a splendid tool for sandy soils.

*Drill Best for Sands.*—It has been clearly shown that the drill grain-sower is the best to use on sands (p. 314). It is best to drill in the clover seed also, not with the grain, but separately and in opposite directions to the grain drill-rows (p. 79).

*Peat for Sand Improvement.*—Many sand sections include numerous peat marshes. When convenient, the peat may be applied to the sands to increase the organic matter and the nitrogen supply. In some countries this is a common practice. Twenty-five loads may be applied to the acre. It is quite necessary to supplement the peat with phosphate and potash fertilizers.

**Crops for Sands.**—Sands respond readily to proper treatment. Moreover, they warm up quickly and are easily worked. When

rightly managed, therefore, they are well adapted for growing potatoes, strawberries, melons, pineapples, garden truck and small fruit.

Following is a brief discussion concerning the growing of other crops.

*Soybeans.*—A splendid legume for sand improvement. Grows well on slightly to medium acid soils. Sands strongly acid should be limed. Inoculation is usually necessary. Usually best to plant in rows. Supply mineral fertilizers. Ranks high in feeding value. A good cash crop (Fig. 129).

*Mammoth Clover.*—An excellent clover for poor sands. Liming necessary if soils are acid. Inoculate for best results. Sow with drill. Top-dress young seeding with manure or mixed fertilizers.

*Cowpeas.*—Of particular value in the Southern states, though adapted to a wide range of climate. May be grown for seed and feed. Inoculation important. Well adapted to slightly or medium acid soils. Hay ranks lower in feeding value than soybeans.

*Velvet Beans.*—A most useful soil-enriching legume for the South. Grows well on acid soils. Inoculate, except when grown on land which has grown lespedeza or cowpeas successfully. On very poor soil use acid phosphate. Has high feeding value.

*Crimson Clover.*—A clover for the Middle Atlantic states. Lime strongly acid soils.

*Medium Red Clover.*—Grows best on non-acid soils. Sow in same manner as mammoth clover. May take the place of mammoth clover when soils become improved.

*Vetch.*—In some sections this plant has not attained the favor as other legumes. First attempts are often failures. Good to sow in rye. Inoculate. Lime strongly acid soils.

*Alfalfa.*—Crop too uncertain. Should not be grown unless soils are well supplied with lime and highly improved. Inoculation necessary.

*Rye* (winter).—Best grain for poor sands. Sow with drill. Top-dress with manure or fertilizers. "Drag" or harrow in the spring. Avoid too thick seeding. Plant early to permit of good winter covering.

*Potatoes.*—Well adapted to sands. Best to follow a green-manuring crop, or be grown on clover sod. Apply mineral fertilizers in drill.

*Corn.*—Can be grown with good success on sands. Best to grow on cover sod.

*Oats*.—Best results when sands are improved.

*Barley*.—Sands are poor barley soils.

*Grass and Pasture*.—Sands poorly suited to grass or pasture.

*Brome Grass*.—Gives promise for good pasturage on sands.

*Buckwheat*.—Well adapted to sands.

*Cotton*.—Cotton grows best on richer soils.

*Sugar Beets*.—Sands are not adapted for the growing of this crop.

**Crop Rotation**.—Short rotations are best for sands. In planning the rotations, legumes, catch-crops and green-manuring crops should be given special consideration; and no grain or cultivated crop should be grown twice in succession. Moreover, rotations must necessarily change to fit the stages of development.

In beginning sand improvement the following rotations are successful:

A—1. Soybeans to plow under (sown on land having had fall rye plowed under). 2. Soybeans for seed or hay (rye sown in the fall). 3. Rye (seeded with mammoth clover or vetch which is plowed under). The clover may be left for hay, and the hay followed by soybeans for seed or hay.

B—1. Soybeans or cowpeas (to plow under or for seed, depending on the soil). 2. Corn or potatoes (fall sown rye or vetch for cover crop).

C—1. Soybeans for seed or hay (fall rye). 2. Rye (soybeans sown immediately after harvest).

The following are typical rotations when a definite system of farming has been established:

D—1. Corn (soybeans planted with corn; fall rye). 2. Rye (seeded with mammoth clover). 3. Clover (second growth plowed under).

This may be made a four-year rotation by growing soybeans after corn. Soybeans may be grown the third year instead of clover.

E—1. Corn (fall rye seeded in corn at last cultivation). 2. Rye (soybeans sown immediately after harvest, and plowed under in fall). 3. Mammoth clover, seed without nurse crop. 4. Clover for hay. Fifth year may be pasture.

F—1. Clover. 2. Corn (rye sown in corn at last cultivation, and plowed under in the spring). 3. Potatoes (rye sown in fall and clover seeded in the spring). 4. Rye.

G—1. Vetch and rye (volunteer vetch plowed under for

potatoes). 2. Potatoes (fall sown rye). 3. Rye (seeded to clover). 4. Clover (second growth plowed under). 5. Corn (soybeans in corn).

H—1. Velvet beans (plowed under), followed by rye (plowed under about May 1). 2. Cowpeas (cut for hay), followed by crimson clover (sown in fall and plowed under about May 1). 3. Corn and velvet beans.

**Types of Farming.**—When the whole farm consists of poor sand, the real problem is to find a way whereby the farmer with limited means can begin at once to realize an income which he can use to improve the soil and to develop a well-balanced and profitable system of farming. It costs money to buy the needed fertilizers and agricultural lime, and it is temporarily expensive to grow certain crops and plow them under. The farmer must begin a system of cropping which will, at the outset, give him fairly certain and continuous returns.

Soybeans, cowpeas and velvet beans (depending upon the section of the country) offer the quickest and surest sources of income. When the sands are poor and organic matter and nitrogen are essential to ensure any crop at all, a portion of the legume crop should be plowed under. If a rotation such as A is planned at the start, one-third of the crop is plowed under (legume), leaving two-thirds of the season's crops for sale. Perhaps after the first three years, or when the three-year rotation is completed on each field, a rotation such as D or E may be established, or a combination of the two. In rotation D the soybeans may be grown for sale as seed, and later on when animals are brought on the farm, or when the number is increased, the soybeans may be grown for forage except when opportunity is afforded to sow the crop after harvesting rye, for green-manuring (rotation E).

During the first few years legumes should constitute the major crop, and at the same time sufficient corn and rye should be produced to meet the feeding requirements of the horses, a few cows and pigs, and a few head of young stock.

Sands afford splendid opportunities for a combination of potato and grain farming, provided particular attention be given the growing of legumes, and to the use of fertilizers and agricultural lime. This type of farming demands much less capital than livestock or dairy farming, though the distribution of labor is not so good.

In many sand sections which are favorably located, dairying seems the best type of farming to be considered. Fences for cows





FIG. 211.—“Hungry soil” Sand. To left, unfertilized. Yield of potatoes, thirteen bushels per acre. Yield of corn, three bushels per acre. (Wisconsin Station.)



FIG. 212.—Profitable sand. Corn on clover sod, manured. (Wisconsin Station.)

are easy to build and dairy cows will turn into profit large quantities of roughage that can be produced so readily on sands. Furthermore, the manure produced can be used to good advantage in soil improvement (contrast Figures 211 and 212). An extra silo for

summer feeding will solve, in a large measure, the problem of summer pasture, which is rather difficult to maintain on sands.

Little need be said concerning sand fields which form parts of many farms. Through intelligent management many of these fields are sources of highly profitable returns. These fields, together with the successful sand farms being operated, indicate the possibilities that may be realized in the proper development of sand lands that are at present considered of little agricultural value.

**Field Studies.**—1. Study systems of sand management, particularly on successful farms.

2. Study the character of subsoil in sandy fields. Which are more desirable than others? Why?

**Home Projects.**—Select three acres of sand or sandy soil, or an acre, and divide into three equal portions. Fertilize properly. Establish a three-year rotation of rye, mammoth clover and corn. Individual students or the school may continue the rotation for at least six years, and observe results.

2. Conduct projects in the proper management of sandy soils as directed in the study of this chapter.

### QUESTIONS

1. Name the four important classes of soils grouped under "sands." How do they differ in texture?
2. What are the indications of a desirable sand farm?
3. Name the special problems in sand management and state briefly the solution of each.
4. What is of the greatest importance in sand improvement? Discuss.
5. Is manure the best fertilizer to use on sand? Discuss its use.
6. Should a sand farmer buy nitrogen fertilizers? Why?
7. Discuss the importance of agricultural lime in sand improvement. What kinds of material may be used? Discuss their application.
8. What mineral fertilizers are best for sands? Discuss their use and application.
9. What are mixed fertilizers? How may they be of value in sand farming?
10. Discuss the preparation of the seed bed on sand.
11. What is the problem concerning the moisture supply in farming sand lands? What means may be employed for solution of this problem?
12. Discuss the "blowing" of sand and its prevention.
13. How should sands be plowed? Explain.
14. Which are better for sowing grain and clover on sands, broadcast sowers or drills? Discuss fully.
15. Tell of the value of peat in sand improvement.
16. Name some crops especially well adapted to sands. What may be said of alfalfa, oats, barley, grass and pasture, sugar beets and cotton?
17. Discuss crop rotation in relation to sand management.
18. What is the main handicap of the farmer of limited means who begins farming on sand, especially when the soil is poor?
19. What types of farming are adapted to sands? Discuss each.
20. Have you seen a case of successful farming of sandy land? Give the elements of success.
21. For an outline summary of this chapter, see table of contents.

## CHAPTER XIX

### MANAGEMENT OF CLAYS AND DEPLETED SILT LOAMS

#### CLAY MANAGEMENT

CLAY soils are quite the opposite of sands in many respects. Sands are loose and open, while clays are sticky and "tight." Sands are the easiest soils to work, and clays the hardest. The special characteristics of clay soils are due largely to their fine texture. They are composed of thirty per cent and more clay, and the remaining material consists of silt and fine sand.<sup>1</sup> They owe their origin, commonly, to the settling out of fine sediments which have been carried into bodies of water by streams.

Included in this class are the "gumbo" soils which are so prevalent in certain sections and localities. Gumbo is usually black clay soil occurring either on river bottoms or flat upland. This soil is more sticky and bakes more easily than any other kind of soil.

**Points in Favor of Clays.**—Heavy clay loams and clays have a few points in their favor, namely: (a) They are excellent for general farming, for hay and grazing; (b) they are well adapted to clovers and small grains; (c) they can usually supply crops with moisture better than sands during a dry period.

**Special Problems.**—Clay soils are highly productive when they are given the proper treatment. The special management problems which they present and their solutions are briefly stated in the table.

#### *Problems in Clay Management and Their Solutions*

Problems	Solutions
Usually cold and wet	Proper surface and subsurface drainage
Difficult to develop good tilth	Thorough drainage; plow when fit; grow grass and pasture
Organic matter and nitrogen usually low	Grow legumes and grass; pasture
Phosphorus often deficient	Use proper phosphate fertilizers
Subject to washing (erosion)	Keep grassed; terrace; deep plowing, etc.

<sup>1</sup> The average mechanical composition of nearly 2000 clays is as follows: Forty-two per cent clay, thirty-six per cent silt, sixteen per cent of very fine sand and fine sand, five per cent medium and coarse sand, and one per cent fine gravel.

**Importance of Drainage.**—Drainage is usually the first step in the improvement of clays, since they are so retentive of moisture and do not permit water to percolate easily through them. Thus it is that clay soils are usually wet and cold and lack proper aeration. Attention should be given both surface drainage and tiling (Chapter IX). Through proper surface and under-drainage these soils warm up better, become better aerated, and are much improved in their productiveness.



FIG. 213.—When heavy soils are plowed too wet they become puddled. Hard lumps result.

**Tilth.**—The greatest problem in the cultivation of clays concerns tilth (see index). When plowed or worked too wet the soil particles are forced together, and the result is a hard, lumpy soil when it becomes dry (Fig. 213). When exposed to a hot, drying sun a moist or wet clay easily bakes. The preparation of a good seed bed, therefore, is difficult and requires much extra labor (see “Clod Crushers”).

Thorough drainage is an important factor in the development of good tilth. A second consideration is careful plowing. Clays should never be plowed or worked when they are wet. Often the bad effects of plowing heavy soils when too wet extends through several years. When such lands have become hard and lumpy because of careless plowing, freezing and thawing is about the only process that will restore a crummy or granular structure. This is best accomplished through fall plowing.

Organic matter has a wonderful effect in loosening heavy soils. Improvement in this direction can best be accomplished by growing grass and by pasturing. Combining red-top, timothy and clover makes an excellent grass mixture for any heavy soil. The roots of grasses loosen the soil and in a large measure prevent puddling.

The growing of sweet clover on clays for soil improvement is highly recommended. The deep roots penetrating the "tight" subsoil improve drainage, favor aeration and add much organic matter (Fig. 214).

The use of air-slaked lime or quicklime on clays tends to develop better tilth, especially when acid. This effect, however, is perceptible only when lime is used continuously for several years. Usually clays are not acid or only slightly so.

**Organic Matter and Nitrogen.**—Clay soils are commonly deficient in organic matter and nitrogen, especially those which



FIG. 214.—The upper portion of a sweet clover root. Such roots will puncture tight and hard subsoils.

were originally covered with forest growth. The growing of grasses and pasturing have been mentioned as means of increasing the organic matter. The plowing under of clover and green manuring crops, and the use of manure are especially recommended as means of increasing the nitrogen supply.

**Phosphates for Clays.**—Heavy soils usually contain large amounts of potassium. When well drained and sufficiently supplied with organic matter potash fertilizers are seldom required on these soils.

The phosphorus needs of clays are quite general, so that the use of phosphate fertilizers is usually highly profitable. For immediate results, acid phosphate may be used at the rate of 200 to 300 pounds per acre for grain and 400 to 500 pounds per acre for corn. Rock phosphate, when mixed with manure or plowed under with clover or green rye, has given excellent results (Fig. 148, p. 198. See Rock Phosphate, index). Basic slag is especially good to use on clays, but in most sections of the United States it is not obtainable.

Many clays are red in color, due largely to the presence of iron compounds. Frequently this iron makes the phosphorus unavailable. On some of these soils acid phosphate is rendered entirely ineffective within a year or two after it is applied. The application of agricultural lime is an effective remedy.

**Erosion.**—Because of their location or topography, many clay soils are particularly subject to washing, or erosion. The cultivation of these lands greatly increases their tendency to wash. In most cases it is best to keep such lands in grass. When some of the more gentle slopes are brought under cultivation, plowing should be done at right angles to the slopes. Often it is advisable to terrace a slope or leave open dead furrows in such a way as to enable the surface water to run off by following more gentle inclines.

Deep fall plowing and subsoiling also aid in preventing erosion (see index). A further discussion of erosion may be found in Chapter XXIII.

**Other Points on Clay Management.**—Clearing clay lands of underbrush, small stumps and dead timber is not, as a rule, a very expensive process. Removing stumps by combining the use of dynamite and the stump puller seems to be the most economical method. It is much easier to blast out stumps when the ground is moist or wet and when they are given a few years to rot after the timber is cut.

When cleared of timber and brush it is advisable to get clover started as soon as possible, not merely to provide pasturage and hay, but to help in controlling the weeds and to improve the soil. A spring-tooth harrow or a disk is helpful in getting the clover seeded.

**Plowing.**—It requires a good plow to turn heavy clays well. In some sections the disk plow is the best to use. Fall plowing is usually advisable. Subsoiling to deepen the seed bed and to create a more open subsoil is sometimes practiced. Dynamite is also used at times to open the subsoil so as to facilitate the entrance of air, water and roots. It is best to do either subsoiling or dynamiting when the ground is sufficiently dry to prevent puddling (Chapter X).

**Crops for Heavy Clays.**—Because of their fine texture, clays are especially well adapted to crops having fine and fibrous roots, such as red-top, timothy, etc.

Crop adaptation to heavy clays may be summarized as follows:

<i>Crops Well Adapted to Clays</i>		<i>Crops Which Can Be Grown Successfully</i>	<i>Crops Not Adapted to Clays</i>
Red-top	Sweet clover	Barley	Vegetables
Timothy	Wheat	Corn	Truck crops
Clover	Oats	Potatoes	Sugar beets
Field peas	Rye	Rutabagas	
		Turnips	

**Rotations and Types of Farming.**—Much depends upon a good system of cropping to increase the productive power of clays. The following are good rotations for dairy farms:

A—1. Corn (manured). 2. Grain (seeded to clover and timothy). 3. Clover. 4. Pasture or mixed hay.

B—1. Wheat (seeded to sweet clover to plow under). 2. Corn (manured). 3. Oats (seeded to clover). 4. Clover.

When the oats are seeded to a mixture of grasses this may be made a five-year rotation with pasture the fifth year.

C—1. Wheat (seeded to clover); (fertilized). 2. Clover. 3. Corn (properly fertilized). 4. Peas (peas for sale as seed).

D—1. Small grain (seeded to mixed grasses). 2. Clover. 3. Mixed hay or pasture. 4. Peas (cash crop). 5. A cultivated crop.

For grain-farming, the following rotation is well adapted:

E—1. Spring wheat (seeded to clover and timothy). 2. Clover (cut for seed). 3. Mixed hay. 4. Peas (for sale as seed).

IMPROVEMENT OF DEPLETED SILT LOAMS

Depleted silt loams are common particularly in the Eastern and Central states. They are the result of too severe cropping,

with little or no attention given to the maintenance of their fertility. As a rule, these soils are low in organic matter and nitrogen, they are commonly acid, and are in need of available phosphorus. Liming is usually the first step to be considered in their improvement, the object being, mainly, to improve the conditions for growing clover and other legumes. Plowing under legumes is recognized as the best method to increase the organic matter and nitrogen. Manure, when available, generally gives good returns when applied to the clover fields. Liberal applications of soluble phosphates should be made to the grain and cultivated crops. Acid phosphate is generally considered the best phosphate fertilizer to use in beginning soil improvement. Later on, when improvements shall have been well advanced, rock phosphate may take the place of the acid phosphate. A short rotation including clover is also an important factor to be considered in the regeneration of these soils (Chapters XII, XIII, XV).

**Field Studies.**—1. Select a run-down farm and make careful observations as regards general appearance, weeds, character of crop growth, and soil conditions. Suggest remedies.

**Home Projects.**—Select three acres of depleted silt loam, or an acre, and divide into three equal portions. Fertilize properly. Establish a three-year rotation, corn, grain and clover. Plow under the first crop of clover, and always the second growth. Students may continue the rotation for at least six years, and note soil improvement.

Other rotations suited may be substituted, or may be conducted in addition to the one suggested.

### QUESTIONS

1. Compare clay soils with sands in their workability and texture. What is "gumbo"?
2. Name the special problems in the management of clays. State briefly their solutions.
3. Discuss drainage in relation to clay management: (a) benefits; (b) methods; (c) depth of tile, fall, "blinding," distance apart to lay lines of tile.
4. Discuss tith in relation to clay management.
5. How may the organic matter and nitrogen in clay soils be increased?
6. What special fertilizer do clays commonly require? What is the relation of lime to fertilizer needs on some clays?
7. What is erosion and how does it affect clay lands? Name some means of prevention.
8. Describe a good method for clearing stumpy clay lands.
9. Name crops that are particularly adapted to clay soils. Crops that can be grown successfully on good management. What crops are not adapted to clays? Why?
10. Name two good rotations for dairy-farming on clay land. A rotation for grain-farming.
11. Discuss the improvement of depleted silt loams.
12. What crops have you observed growing on very heavy clay soils?
13. See outline summary of this chapter in table of contents.



## CHAPTER XX

### FARM MANAGEMENT AND CROP ROTATION

**Soil Problems Are Prominent in Farm Management.**—The most successful system of farming is that which gives the largest profit, increases soil fertility, and brings to the farmer and his family the largest amount of happiness. Successful farm management presents many problems, the most important of which concerns the growing of suitable crops, the adaptation of crops to soil, the care of the soil and crops, the disposition made of the crops, and the distribution and use of labor. The problems involving soil relations are usually of fundamental importance and thus are given special attention. Indeed, it is self-evident that productive soil is the basis of profitable farming.

The old style of farming has been largely the one-crop system—a system which has generally led to soil depletion. Modern agriculture and scientific farming demands the growing of several crops, chiefly because of its beneficial effects on soil fertility. Thus diversified farming has become of national importance.

**Advantages in Growing Different Crops.**—There are several advantages to be gained in growing different kinds of crops, important of which are: (a) It economizes in the use of labor; (b) a more dependable income is assured; (c) it permits of crop rotation.

Different kinds of crops necessarily require different planting and harvest times. The labor required to care for the crops is extended more uniformly over a longer period than when just one crop is grown. Moreover, a diversity of crops encourages the keeping of more livestock, the care of which utilizes labor, especially during winter months.

The growing of one crop means just one source of farm income, and that is rather uncertain at times. The growing of several crops provides a more dependable income. When the weather is bad or prices low for one crop, the conditions or prices are usually favorable for some other crop. To establish more than one source of income is good business.

It is self-evident that rotation is made possible only when

two or more different crops are grown. The importance of rotation in farm management and its application are fully discussed in the following paragraphs.

**Rotation an Essential Factor in Farm Management.**—Crop rotation is a most essential factor in successful farm management, because it aids materially in increasing and maintaining soil fertility, in systematizing farm operations, and in solving certain other soil and crop problems. The relation of rotation to soil fertility has been fully discussed in Chapter XV.

Rotation implies system. The adoption of definite cropping plans is the beginning of systematic farming, affecting not only the growing of crops, but field management and the use of labor as well.

Problems concerning the adaptation of crops to certain fields, the effect of one crop on another, soil renovation, the management of special soils, etc., are best solved through crop rotation.

**Rotation in Practice.**—In establishing a fixed rotation, it is necessary to divide the farm into uniform fields or units on which are grown the different crops. Each year the crop on each field or unit is changed according to the adopted plan. For example: A certain farm consists of 100 acres, sixty acres of which are under cultivation and are divided into three twenty-acre fields; the remaining forty acres includes permanent pasture, orchard, yard, garden, etc. The farmer wishes to grow annually twenty acres, each, of corn, oats and clover; thus a three-year rotation is planned as follows:

	Field I	Field II	Field III
Year 1. . . . .	Corn	Oats	Clover
Year 2. . . . .	Oats	Clover	Corn
Year 3. . . . .	Clover	Corn	Oats

This is the simplest conception of a practical rotation. Comparatively few farms, however, lend themselves to such a simple arrangement because of certain conditions or factors which present themselves. Usually two or more different rotations are necessary on each farm.

**Factors Which Determine Kinds of Rotations.**—The rotations best suited to any particular farm are determined by—

- (a) The feeding requirements of the stock kept.
- (b) The kind and amount of cash crops grown.

- (c) The income to be derived.
- (d) The profitable distribution of labor.
- (e) The topography of the farm.
- (f) Soil conditions.

*In stock farming*, the feeding requirements determine in a large measure the kind and amount of crops to be grown; and this must necessarily vary with different types of stock farming. Besides growing the crops required for feed, most farmers grow additional cash crops, such as wheat, barley, tobacco, sugar beets, cabbage, etc. This usually complicates the general cropping plans. Usually the growing of alfalfa also causes irregularities in the rotations.<sup>1</sup> Rotations on grain farms may be different than those on stock farms; and the systems of cropping in truck farming are quite unlike all others. Moreover, rotations in one section of the country differ from those of another, because of dissimilar crop adaptation.

*The income to be derived* and the distribution of labor are of special importance in determining rotations, especially in grain-farming and in the growing of truck crops, since the object uppermost in the mind of most farmers is not soil improvement, but the making of money. These two endeavors, however, can be happily combined. It is much easier to plan rotations and arrange fields on land that is level or slightly rolling than on a hilly farm. Many farms have hillsides which must necessarily be cropped in a different manner than the more level portions in order to control soil erosion.

*Soil conditions* most frequently affect the rotations. For example, many soils are strongly acid, which condition is unfavorable for certain crops (Chapter XIII). Peat and muck soils, sands and heavy clays require special attention with respect to cropping. A field of depleted silt loam should not be included in rotation plans designed for highly productive fields.

**Procedure in Planning Rotations.**—Rotations on many farms can be planned and carried out with little or no difficulty. On old farms, it is not always easy to establish fixed or definite rotations. Usually it becomes necessary to reorganize the whole farm.

---

<sup>1</sup> When a farmer succeeds in getting a good field of alfalfa he usually leaves it in alfalfa so long as it produces profitable crops. A rotation including alfalfa is always longer and usually more irregular than a rotation in which clover is grown as the principal legume.

In doing this it is important to keep in mind the entire business of any particular farm so that whatever rotations are adopted they will not disturb in any great degree the type of farming already established, unless the farming business itself is radically changed. Moreover, in reorganizing any farm, two or three years may be required before the revised cropping plans can be fully adopted, because existing conditions must be considered, as regards pasture, hay fields, size and arrangement of fields, drainage, etc.

Bearing in mind all the determining factors, the procedure in planning rotations for any particular farm may best be started in the form of problems, or cases, as follows:

**Case A.—A stock farm already stocked.**

1. First determine the amount of grain, corn and hay, etc., necessary to meet the feeding requirements.

2. Determine the average yields on the farm.

3. Determine the acreage necessary to produce the required crops for feed.

4. Make a map of the farm just as it is with fields showing acres in each.

5. Number the fields in some convenient way.

6. Consider the rotations best suited to soil conditions or types of soil in each field or on various portions of the farm

7. Plan to grow each year the required amounts of the different crops.

8. Rearrange the fields if necessary to simplify the cropping plans and to aid in general field management.

**Case B.—A farm designed for stock but not yet stocked.**

1. Determine the kinds of stock to be kept.

2. Determine the acreage available for growing crops (including pasture).

3. Ascertain the average yields of the crops to be grown.

4. Estimate the amount of stock that can be conveniently kept.

5. Determine definitely the acreage necessary to grow the crops required for feed.

6. Proceed as in Case A, point 4.

**Case C.—A grain farm, with soil problems.**

1. Make a map of the farm; show fields, acreage, and indicate soil problems and conditions.

2. Determine crops to be grown.

3. Plan rotations best for special soils, to improve poor soils in certain fields, and to best meet other soil conditions.

4. Rearrange the fields or combine small fields into larger units, whenever possible, to facilitate farm management. (When no special soil problems or conditions are to be met, the fields may be rearranged at once and the proper rotations adopted.)

**Case D.—Rotations in truck farming, with soil problems.—**Proceed as in Case C.

**Crop Rotation Chart.**—In planning rotations on farms having soil and crop problems which must necessarily complicate the cropping plans, a *rotation chart* is of great help. For example, the cropped portion of a farm, excluding permanent pasture, consists of sixty acres, which are divided into six ten-acre units. Twenty acres each of corn, oats and hay (ten of alfalfa) are to be grown annually.

Fields I and IV are especially well adapted to alfalfa.

Fields II, III and VI require improvement, hence a three-year rotation is planned for each of these three fields (p. 273).

Fields IV and V, and also I, are highly productive and hence can well take care of irregularities in the cropping plans, as is shown in the following outline:

A Rotation Chart

Year	Field I	Field II	Field III	Field IV	Field V	Field VI
1 . . .	Alfalfa	Oats (seeded) (fertilized)	Corn (on sod) (manured)	Oats (seeded with mam- moth clover)	Corn	Clover (Top- dressed with manure)
2 . . .	Alfalfa	Clover	Oats (seeded) (acid phosphate)	Corn (manured)	Oats (seeded to mammoth clover)	Corn (manure) (acid phosphate)
3 . . .	Alfalfa	Corn (fertilized)	Clover (light dressing manure)	Oats (seeded to alfalfa)	Corn (manured)	Oats (seeded) (acid phosphate)
4 . . .	Corn	Oats (seeded) (acid phosphate)	Corn (manured) (acid phosphate)	Alfalfa	Oats (seeded to mammoth clover; rock phosphate)	Clover (Top- dressing of manure)
5 . . .	Oats	Clover (Top- dressed with manure)	Oats (seeded) (acid phosphate)	Alfalfa	Corn (manured)	Corn (acid phosphate)

**Application and Illustrations.**—A few typical illustrations are here given in the form of problems to show how rotations may be established and how certain soil and crop problems can best be solved through rotation.

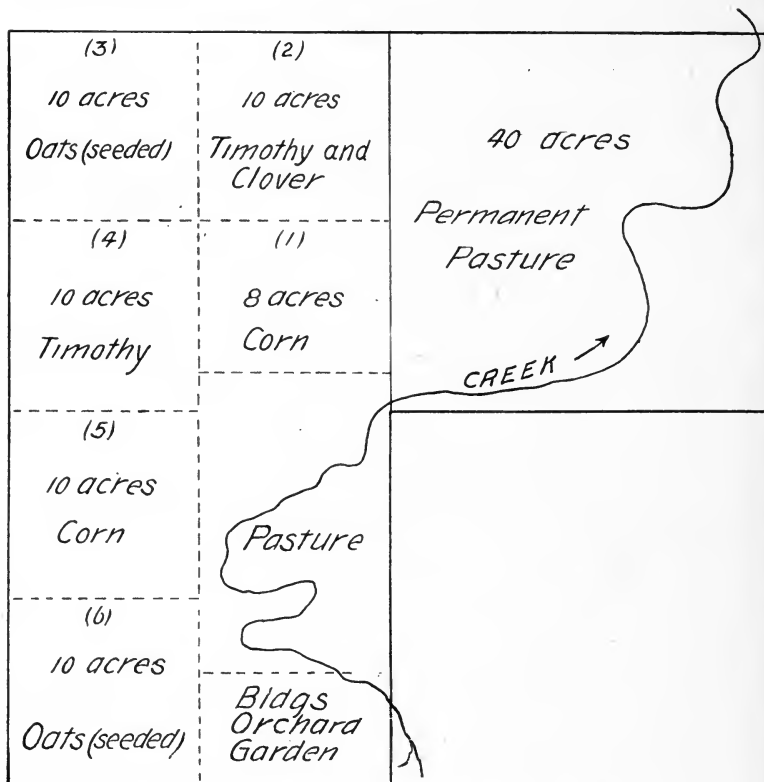

FIG. 215.—Conditions when rotation was first considered.

**Problem I.**—Plan a fixed rotation for a dairy farm which is already stocked.

Size of farm—120 acres, all silt loam.

Corn, oats and clover are to be grown.

About 100 to 125 tons of silage, about 500 bushels of corn, at least thirty tons of clover, and about 800 to 1,000 bushels of oats are necessary to meet the feeding requirements.

Corn yields at the rate of ten to eleven tons of silage per acre, or fifty to sixty bushels of corn; oats average about forty bushels, and clover about one and three-quarters ton per acre.

To meet the feeding requirements, at least twenty acres of

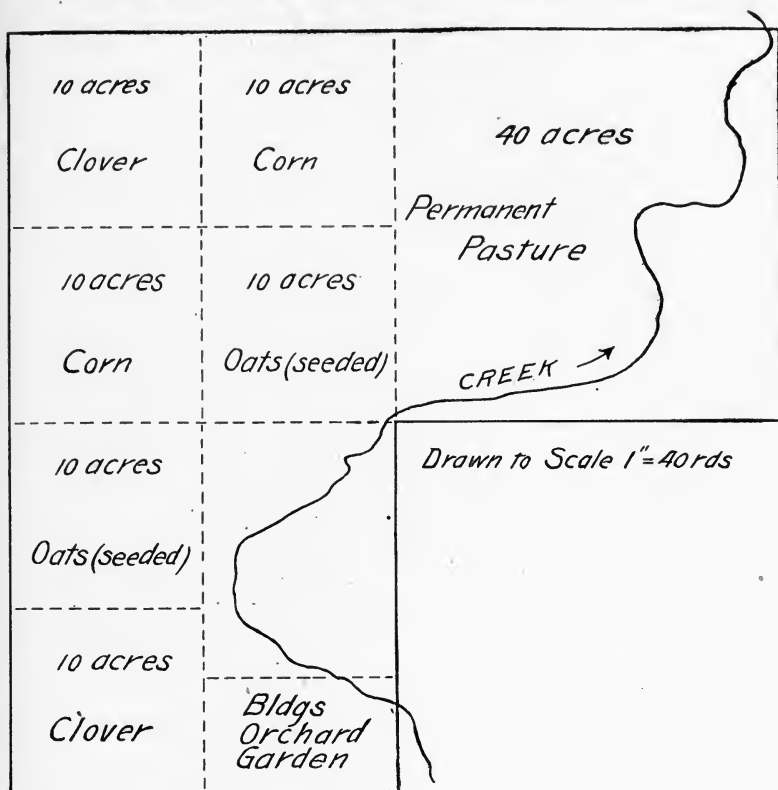

FIG. 216.—Cropping plans the second year after planning.

each crop must be grown. Fifty-eight acres are now under cultivation. Figure 215 shows the arrangement of the farm when rotation was first considered.

The important soil problems are (a) a lack of available phosphorus, and (b) a comparatively low supply of nitrogen and organic matter.

In order to work towards a fixed rotation without disturbing

the farming business, the second year the fields were cropped as is shown in Figure 216. Note that the timothy sods were plowed up and field number one was made two acres larger.

The third year the fields were rearranged as is shown in Figure 217—a fixed three-year rotation being established.

The rotation planned and soil improvements to be made are indicated in the following rotation chart:

*Rotation Chart for Problem I*

Year	Field I (20 acres)	Field II (20 acres)	Field III (20 acres)
1. . . . .	Hay	Corn (manured; 400 lbs acid phosphate per acre)	Oats (seeded) (200 lbs. acid phosphate)
2. . . . .	Corn (manured; 400 lbs. acid phosphate per acre)	Oats (seeded) (200 lbs. acid phosphate)	Clover
3. . . . .	Oats (seeded) (200 lbs. acid phosphate)	Clover	Corn (manure + 400 lbs. acid phosphate per acre)
4. . . . .	Clover	Corn (manure + rock phosphate)	Oats (seeded) (200 lbs. acid phosphate per acre)
5. . . . .	Corn (manure + 1000 lbs. rock phosphate per acre)	Oats (seeded)	Clover

*Problem II.*—Plan definite cropping plans for an eighty-acre farm which is intended for dairying.

Just seventy-four acres are available for raising the main crops—hay, grain and corn.

Yields of crops would support, at the start, at least fifteen cows, a few young stock, four horses and some pigs.

Summer feeding to be silage, soiling crops, grain and whatever pasturage may become available. The farmer expects to buy whatever additional feeds are required.

Twelve acres of alfalfa, twelve to thirteen acres of clover, twenty-four to twenty-five acres of corn, and twenty-four to twenty-five acres of grain are to be grown annually.

Figure 218 shows the existing conditions as regards the fields, permanent fences, hay fields, etc.

The farm consists entirely of silt loam. Fields numbers two and three are especially well adapted to alfalfa. Field four (a) is the poorest field.



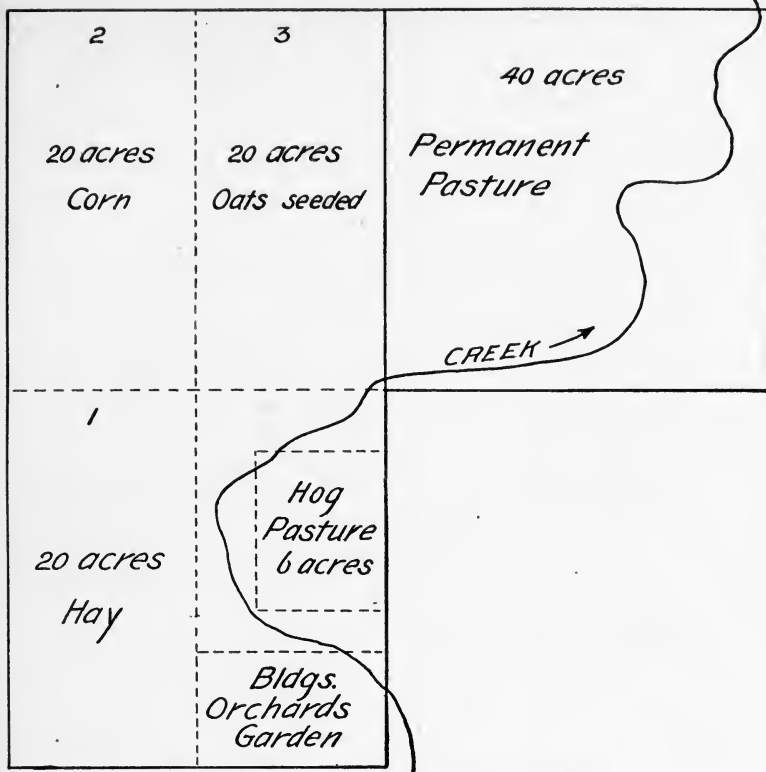

FIG. 217.—A fixed three-year rotation established.

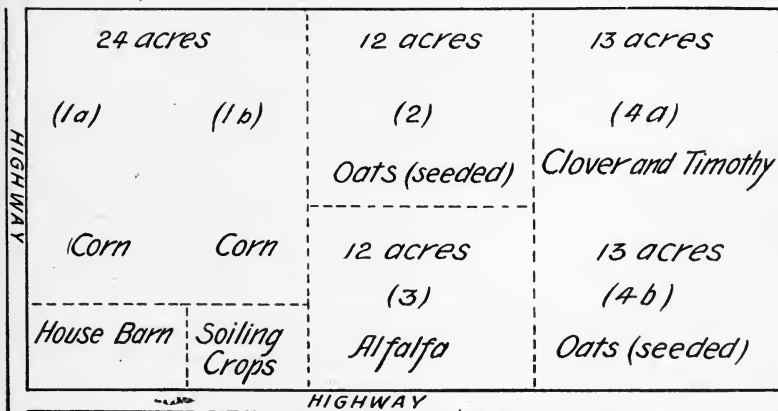

FIG. 218.—Crop rotation on an eighty-acre farm. (Problem II.)

Because of the twelve acres of alfalfa the farm must necessarily be divided into six units of twelve and thirteen acres each.

The following rotation chart shows the final cropping plans and fertilizer treatments for this farm.

*Rotation Chart for Problem II*

Year	Field I (a) (12 acres)	Field I (b) (12 acres)	Field II (12 acres)	Field III (12 acres)	Field IV (a) (13 acres)	Field IV (b) (13 acres)
1 . . . .	Corn	Corn (manured)	Oats (seeded to mammoth clover to plow under)	Alfalfa	Clover and timothy	Oats (seeded)
2 . . . .	Oats (seeded)	Oats (seeded to mammoth clover)	Corn (manure + phosphate)	Alfalfa	Corn (manure + acid phos- phate or bone meal)	Clover
3 . . . .	Clover	Corn (manured)	Barley (seeded to alfalfa)	Alfalfa	Oats (seeded) (soluble phosphate)	Corn (manure + phosphate)
4 . . . .	Corn (manured)	Oats	Alfalfa	Corn (manured)	Clover	Oats (seeded)
5 . . . .	Oats (seeded)	Corn (manured)	Alfalfa	Oats (seeded to clover)	Corn (manured) (acid phos- phate)	Clover

*Problem III.*—Plan a system of cropping on an eighty-acre grain farm in Arkansas, on which are to be grown cotton, corn, cowpeas and oats as the main crops. Sufficient pasture is to be provided for the horses and mules and for a few head of cattle. As many hogs are to be kept as conditions well permit.

Soil problems to be met are, drainage and deficiency of organic matter and phosphorus.

Figure 219 illustrates the conditions before reorganization.

Figure 220 shows how the farm was remapped. The drainage problem was easily solved by tiling.

The following four-year rotation was adopted:

1—Cotton followed by a winter cover crop, such as winter grain, crimson clover and bur clover, plowed under.

2—Cowpeas, planted in May and harvested in August.

3—Oats or wheat. (Followed by cowpeas, plowed under).

4—Corn (The corn may be interplanted with cowpeas, soybeans or velvet beans, which will furnish hog feed and also serve as a green manuring crop for next year's cotton.)

The cowpeas, velvet beans or soybeans planted in the corn may be used to fatten hogs.

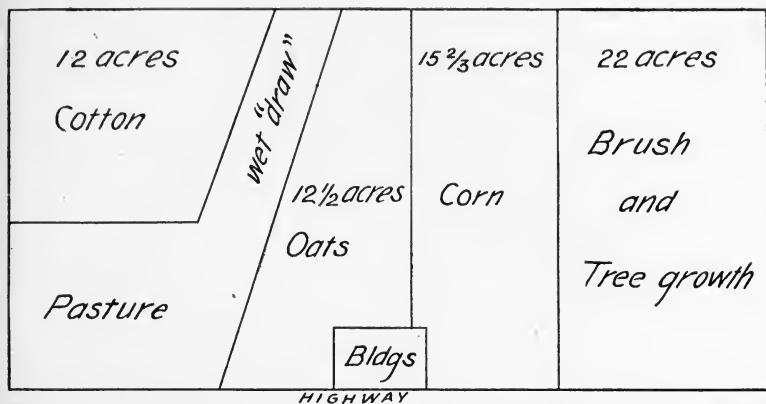

FIG. 219.—A farm unorganized. (See Fig. 220.)

The land surrounding the building-lot and garden may be used for the growing of some sweet potatoes, and for hog pasture. The

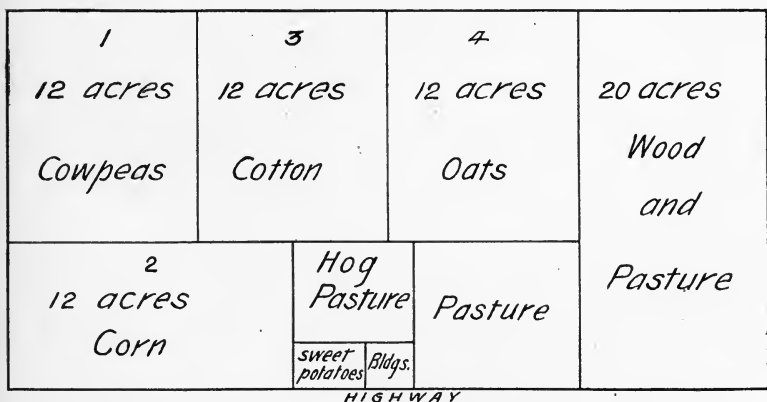

FIG. 220.—The same farm organized.

three acres for hog pasture may be divided into three one-acre fields and cropped to different crops for successive pasturing. Oats and rye may constitute early pasture, clover for later pasture and soybeans or velvet beans later on.

The plan of rotation and fertilization for this farm is summarized in the following rotation chart:

*Rotation Chart for Problem III*

Year	Field I (12 acres)	Field II (12 acres)	Field III (12 acres)	Field IV (12 acres)
1.....	Cowpeas	Corn (500 lbs. acid phosphate per acre)	Cotton (800 lbs. acid phosphate + 600 lbs. cotton-seed meal per acre)	Oats (followed by cowpeas)
2.....	Oats (cowpeas to plow under)	Cotton (500 lbs. acid phosphate + 600 lbs. cotton-seed meal)	Cowpeas	Corn (manure + 500 lbs. acid phosphate per acre)
3.....	Corn (500 lbs. acid phosphate + available manure)	Cowpeas	Oats (followed by cowpeas to be plowed under)	Cotton (500 lbs. acid phosphate + 600 lbs. cotton-seed meal per acre)
4.....	Cotton (500 lbs. acid phosphate + 600 lbs. cotton-seed meal)	Oats (followed by cowpeas)	Corn (500 lbs. acid phosphate per acre)	Cowpeas
5.....	Cowpeas	Corn (500 lbs. acid phosphate per acre)	Cotton (phosphate fertilizer)	Oats (followed by cowpeas)

*Problem IV.*—Sometimes it becomes necessary to produce much more hay than either corn or grain. This does not necessarily mean that a definite rotation is not possible. For example, on a certain farm 125 acres are under cultivation, and 115 acres are permanent pasture. The farmer wishes to raise each year in rotation twenty-five acres of oats, thirty-five acres of corn and sixty acres of hay.

One hundred twenty acres may be laid out into three forty-acre fields, and each field cropped as is shown in Figure 221.

*Problem V.*—Plan a system of cropping on a 160-acre farm in Wisconsin, which consists of twenty acres of drained peat, twenty acres of fine sand, twenty acres of permanent pasture, and the remaining portion of the farm consists of silt loam. All soils are sufficiently supplied with lime.

The following crops are to be grown: Forty acres of corn, about thirty acres of hay (about ten of alfalfa), thirty to thirty-five acres

of grain, twenty acres of pasture in rotation, four acres of sugar beets, and four acres of cabbage.

Figure 222 shows the organization of the farm into eight fields of nineteen and twenty acres each, except field VII, which contains sixteen acres.

The plan of cropping is shown in the accompanying rotation chart:

*Rotation Chart for Problem V*

Year	Field I (20 A) sand	Field II (20 A)	Field III (19 A)	Field IV (20 A)	Field V (20 A) peat	Field VI (19 A)	Field VII (16 acres)			
							4 acres	4 acres	4 acres	4 acres
1	Rye (mammoth clover)	Corn	Clover	Pasture	Corn	Alfalfa (9½ A) Oats	Clover	Cabbage	Sugar beets	Oats (seeded)
2	Clover	Oats	Pasture	Corn (10 A) Wheat (10 A)	Corn (rape)	Alfalfa Corn (9½ A)	Cabbage	Sugar beets	Oats (seeded)	Clover
3	Corn	Clover	Pasture	Oats	Corn (rape)	Alfalfa Barley (Alfalfa) Corn	Sugar beets	Oats (seeded)	Clover	Cabbage
4	Rye (followed by soybeans)	Pasture	Corn	Clover Oats (10 A)	Corn (10 A) Oats for hay (seeded)	Alfalfa	Oats (seeded)	Clover	Cabbage	Sugar beets
5	Corn	Pasture	Oats	Corn	Oats for hay (seeded) Hay (10 A)	Oats (9½ A) Alfalfa	Clover	Cabbage	Sugar beets	Barley (seeded)
6	Rye	Corn	Clover (9½ A) Corn (9½ A)	Barley (10 A) (Alfalfa) Corn	Pasture	Clover (9½ A) Alfalfa	Cabbage	Sugar beets	Barley	Clover

Note the cropping plan on the sand field, on the peat soil and on field VII. Fields VI and IV are the two best fields on which to grow alfalfa.

Manure is judiciously used. Some commercial fertilizers are used on the sand field. Potash and acid phosphate are applied to the peat soil. Both acid phosphate and rock phosphate are used to reinforce the manure used on the silt loam.

Rape is sown in the corn on the peat for pasturage and for soil improvement.

**Other Points on Rotation.**—In cropping hillsides, care should be given to lessen erosion. Such fields should be kept in grass as much as possible.

In growing alfalfa, it is often convenient to divide a portion of the farm into strips or units and on each strip practice a five-year

	Field I	Field II	Field III
Year 1	Corn (35 acres)	Oats (seeded) (25 acres)	Clover and timothy
	Peas and oats	Peas and oats (10 acres)	Timothy and clover
Year 2	Oats (seeded) (25 acres)	Clover and timothy	Peas and oats
	Peas and oats for hay	Timothy and clover	Corn (35 acres)
	Clover and timothy	Peas and oats	Clover and timothy
Year 3	Clover and timothy	Corn (35 acres)	Peas and oats (10 acres)
	Timothy and clover	Oats (seeded) (25 acres)	Oats (seeded) (25 acres)

FIG. 221.—Sixty acres of hay, thirty-five of corn and twenty-five acres of oats in rotation.

rotation: for example, a thirty-acre field may be divided into five six-acre strips and cropped as follows:

*Rotation Chart for Alfalfa*

Strip	Year 1	Year 2	Year 3	Year 4	Year 5	Year 6
I	Alfalfa	Corn	Grain	Alfalfa	Alfalfa	Alfalfa
II	Alfalfa	Alfalfa	Corn	Grain	Alfalfa	Alfalfa
III	Alfalfa	Alfalfa	Alfalfa	Corn	Grain	Alfalfa
IV	Grain (seeded to alfalfa)	Alfalfa	Alfalfa	Alfalfa	Corn	Grain
V	Corn	Grain	Alfalfa	Alfalfa	Alfalfa	Corn

When clover fails, a suitable legume should be sown in place of it, such as soybeans. Often oats or oats and peas are sown for hay when the clover kills out. If in problem V, for example, the

clover on field III should kill out, the first year, the field could be seeded to oats or oats and peas for hay. The oats should be seeded to clover and timothy to provide pasture the following year. Suppose further, the clover on field I should winter-kill the second

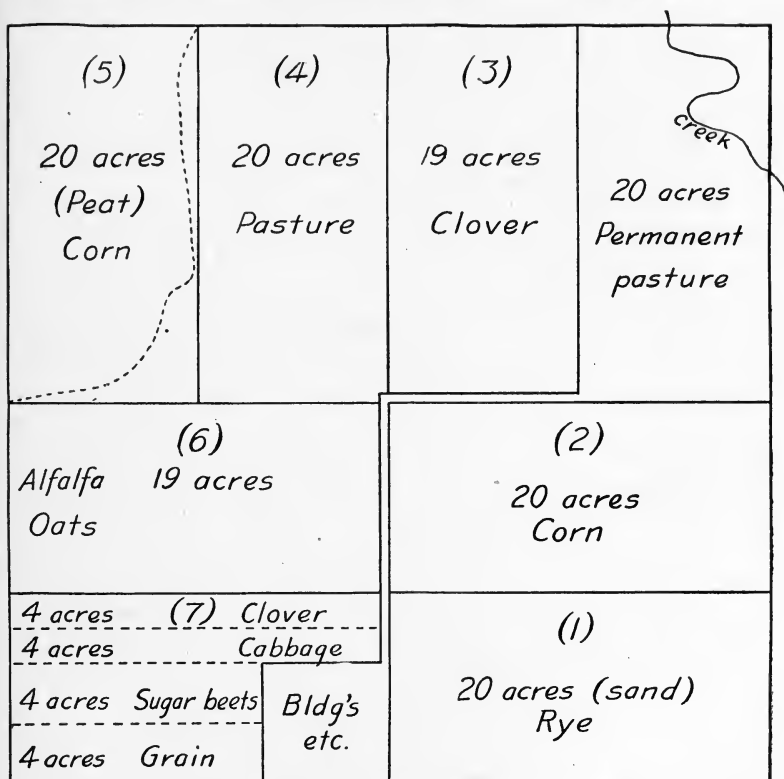

FIG. 222.—Rotations meeting several problems.

year—soybeans could be sown for hay, and corn planted on the field the third year as it is planned.

**Summary.**—Crop rotation is possible on any farm. It should be the first duty of a farmer to adopt definite cropping and fertilizing plans for his land. It matters not where the farm, there are adaptable legumes that can be grown in the rotation not only for forage and seed, but for soil improvement as well. Systematic farming has its beginning in systematic crop rotation.

**Field Study.**—Study some particular farm having soil and crop problems, and suggest proper rotations.

**Home Projects.**—Each of the rotations given in this chapter may be used as the basis for starting good home projects. Vary them to suit local conditions.

**Planning Farms.**—Farms of the region should be drawn to show the plans of the fields and the rotations. After the foregoing studies have been made many suggestions for the improvement of the rotations may be made.

### QUESTIONS

1. Name some of the problems which present themselves in farm management?
2. Discuss the importance of the problems involving soil relations.
3. What is meant by diversified farming?
4. Discuss the advantages in growing different crops.
5. Discuss the importance of crop rotation in farm management.
6. Explain briefly how crop rotation is practiced on the farm.
7. Can this be simply done on all farms?
8. Name the factors which determine the rotations best suited to any particular farm. Discuss each point.
9. Under what conditions is it best to allow two or three years before definite rotations can be fully adopted?
10. How is it best to proceed in planning rotations for a farm already stocked?
11. For a farm intended for stock but not yet stocked?
12. For a grain farm?
13. In truck farming?
14. Discuss the advantages of a rotation chart. Illustrate.
15. Explain the solution to Problem I. Go to the blackboard.
16. Explain the rotation system in Problem II.
17. Explain the reorganization and cropping plans in Problem III.
18. Explain the rotation principle involved in Problem III.
19. In Problem V, extend the rotation chart over the seventh, eighth, ninth and tenth years.
20. Suppose in the third year all the clover and alfalfa should winter-kill, what can be done to meet the situation?
21. Explain a scheme for growing alfalfa in rotation.
22. Plan rotations for a farm with which you are familiar.



## CHAPTER XXI

### SYSTEMS OF FARMING AND THEIR RELATION TO SOIL FERTILITY

THE important problem in agriculture concerns the maintenance of soil fertility which, in a large measure, determines the future welfare of a state or a nation. Good farming is commonly regarded as the proper method wherein soil fertility may be maintained, or permanent agriculture established. Does good farming necessarily mean stock farming?

**Systems of Farming.**—Three main systems of farming are recognized, namely: (a) grain farming; (b) stock farming, and (c) truck farming. Aside from these there are combinations of two or all three systems. The first two systems are the most common.

Grain farming, in its strict sense, may be defined as that system of farming in which crops are raised and sold off the farm. Crops include corn, small grains, cotton, seeds, etc.

Stock farming consists in the raising of stock. The crops grown are fed on the farm. The sources of income are stock and animal products (Fig. 223).

#### GRAIN FARMING VS. STOCK FARMING

**Grain Farming Is Important.**—A large percentage of the farmers in the United States are grain farmers. Many have found it more profitable than stock raising. A well-balanced national agriculture demands that a large portion of the farmers be grain growers, because grains constitute the great source of human foods. This fact is emphasized the more in densely populated countries, as in China.<sup>1</sup> Furthermore, many more people can be fed on the grain that can be grown on an acre, for example, than on the animal products that may be produced when the grain is fed to livestock.<sup>2</sup> It follows, therefore, that the greater the density

---

<sup>1</sup> Farmers of Forty Centuries, by King.

<sup>2</sup> It has been roughly estimated that twenty-four per cent of grain is recovered for human food in pork, about eighteen per cent in milk, and only about three and five-tenths per cent in beef and mutton. Science, Vol. XLVI., No. 1181, page 160.

An acre of wheat yielding twenty bushels will furnish more than thirteen times as much energy as an acre devoted to beef production.—U. S. Farmers' Bulletin, 877.

of population of a country the greater the necessity for grain production.

**Grain Farming Has Led to Soil Depletion.**—It is common knowledge that wherever grain farming has been practiced extensively in the United States soils have become rapidly depleted. The growing of wheat in the pioneer days is a good example. It is for this reason that grain farming is commonly regarded as a soil-robbing or “soil-mining” enterprise.



FIG. 223.—Stock farming is popular. It puts life into farming.

**Grain Farming Revised.**—Fortunately, the relation of crop production to soil fertility is now better understood, so that it is possible for a grain farmer to realize a profit and at the same time maintain, and actually increase, the fertility of his soil.

The old system of grain farming consisted in the growing of one kind of grain after another, or growing the same crop continuously. No effort was made to restore any of the plant-food elements removed by the crops. The straw was burned because it was considered of no value, not even as a fertilizer.

Scientific research and good farming methods have taught that on most soils the nitrogen and organic matter may be maintained and increased by practicing a proper rotation including a legume as a green manuring crop, or including both a green manuring crop and another legume as a cash crop. The phosphorus supply may be maintained by using phosphate fertilizers. The potassium is given little consideration because most of the heavier soils are abundantly supplied with this element. When-

ever, potassium is deficient, potash fertilizers may be used. Moreover, scientific grain farming demands that all stalks and straw be returned to the soil. In this manner the draft on the soil supply of potassium is greatly lessened.

**An Ohio Trial in Grain Farming.**—At the Ohio Station the following system of grain farming has been under test for eight years:

Year 1—Corn (400 pounds acid phosphate per acre; stalks left on field).

Year 2—Soybeans for sale as seed (straw returned to the land).

Year 3—Wheat (300 pounds acid phosphate per acre; straw returned to land, mostly for corn; wheat seeded to clover).

Year 4—Clover (plowed under for soil improvement, or first crop cut and left on ground and second crop cut for seed).

This test is on acid soil limed with pulverized limestone.

This system thus far has resulted in an increase of corn from 49.6 bushels as the average for the first two years (1910–1911), to 63.5 bushels as an average yield for the seventh and eighth years. The yield of wheat, likewise, was increased from 29.5 to 32.7 bushels.

**Stock Farming Popular.**—Stock raising is commonly regarded as the best system of farming. Grain growers are usually advised to become stockmen. It is certain that all farmers cannot be live-stock farmers in the strict sense, because meat and other animal products can never take the place that grains do in human feeding.

It is generally believed that stock farming is the solution of the soil fertility problem. This, however, is not an established fact. It is true, nevertheless, that crop yields are usually better on stock farms than on grain farms—considering the ways in which these two systems of farming are ordinarily carried on. This is because the production of manure in the care of stock has made it possible for the stock farmer to fertilize his land whether he believed in soil enrichment or not.

**Maintaining Fertility by Live-stock Not Probable.**—According to the thirteenth census there is in the United States the equivalent of one animal of the horse or cattle kind<sup>3</sup> to furnish manure for the maintenance of the fertility of 9.07 acres (farm lands, only, considered). One cow at best can, on an average, take care of about two acres a year—considering a three-year rotation of corn, grain and clover. Under these conditions soil fertility in a national sense cannot be maintained without the aid of other fertil-

<sup>3</sup> When ten sheep or ten hogs are regarded equivalent to one horse or one cow for fertility maintenance.—Ohio Station Bulletin 328, 1918.

izing materials. On only a comparatively few stock farms is there sufficient manure produced by the feeding of the crops raised to permit the application of about fourteen or sixteen tons of manure per acre once in three or even four years on all the cultivated fields. Even when this is done unavoidable losses occur, especially of phosphorus, which compels recourse to outside sources, particularly the mineral commercial fertilizers.

**Grain Farming and Stock Farming Compared.**—Parallel to the system of grain farming already mentioned, the Ohio Station is running a system of stock farming in which the same amounts of acid phosphate and limestone are used and the same crops are raised. All the crops, except the wheat and whatever clover seed is produced, are either fed to livestock or passed into the manure as bedding.<sup>4</sup> The manure made each year is applied to the corn land. These two tests occupy nine acres which are divided into two parts—one-half of which is farmed in livestock and the other in grain farming. The experiment is so planned that each crop is grown every year. The animals are kept in a large box stall, heavily bedded on a cement floor under cover, so that all manure, both solid and liquid, is saved and applied to the land in the spring.

The results for the first eight years are given in the table.

*Grain Farming vs. Stock Farming in Maintaining Soil Fertility*

Crops	Average Yields per Acre in Grain Farming		Average Yields per Acre in Stock Farming	
	Grain or Seed	Hay, Stover or Straw	Grain or Seed	Hay, Stover or Straw
	<i>Bu.</i>	<i>Tons</i>	<i>Bu.</i>	<i>Tons</i>
Corn . . . . .	58.6	None harvested	64.6	1.55
Soybeans . . .	19.0	0.87	21.9	1.00
Wheat . . . .	28.7	1.32	32.4	1.55
Clover . . . .	Not gathered		. . . .	2.23

Relative profits were not discussed, since these tests are not concluded. The amount of labor and equipment required in these two systems of farming are important factors to be considered in determining net profits.

At the Illinois Station similar tests have been carried on since 1902.<sup>5</sup> The crops grown in rotation, soil treatment and yields are given in the next table.

<sup>4</sup> Ohio Station Bulletin 328.

<sup>5</sup> University of Illinois Bulletins 125 and 219 and Circular 193.

*Grain Farming vs. Stock Farming in Maintaining Fertility*

Soil Treatment	10-year average 1908-1917			7-year average	6-year average
	Corn	Oats	Clover	Wheat	Alfalfa
No treatment (same rotation) . . . . .	<i>Bu.</i> 52.6	<i>Bu.</i> 49.3	<i>Tons</i> 1.97	<i>Bu.</i> 21.9	<i>Tons</i> 2.33
Residue,* lime, phosphate Grain farming	72.0	67.2	2.30	42.5	3.56
Manure, lime, phosphate Stock farming	73.7	66.8	3.07	40.1	3.58
Increase in good farming	20.3	17.7	0.72	19.4	1.24

\* Residue means grain straw, corn stalks, clover straw, chaff, etc.

Lime.—Application of 250 pounds air-slaked lime per acre in 1902; 600 pounds pulverized limestone per acre in 1903; beginning with 1911, pulverized limestone is added at the average rate of two tons per acre every four years.

Manure is applied at the rate of one ton for every ton of produce.

Phosphate.—200 pounds of bone meal were applied to the acre annually up to 1908, then plot was divided and one-half continued to receive bone meal at the average rate of 200 pounds per acre per year.

To the other half is applied rock phosphate at the average rate of 600 pounds per acre per year.

These results show clearly that a good grain farmer can maintain and increase the fertility of the soil.

**Combination of Grain and Stock Farming.**—The fact that considerable roughage is produced on grain farms has encouraged the keeping of more or less livestock to convert this by-product into useful animal products, and at the same time manure is produced for use as fertilizer. Thus, roughages of one kind or another will, no doubt, give the dairy cow and the beef animal especially, a place in our agriculture for a long time to come.

## AN ACCOUNT WITH THE PLANT-FOOD ELEMENTS IN FARMING

**Nitrogen and Phosphorus Balance Indicative of Good Farming.**

—There are several factors which determine the productive power of soils. When all other conditions are favorable, however, the balance of nitrogen and phosphorus in the soil in any rational system of farming will indicate very clearly the tendency towards soil enrichment or soil depletion. For example, the draft per acre on the plant-food elements on a grain farm during a four-year period when the corn is “snapped”<sup>6</sup> and no straw is returned, may be as follows:

<sup>6</sup> When the ears are jerked off the stalks in the field this method of harvesting is called “snapping the corn.” The stalks are left in the field.

Crop	Yield	Nitrogen	Phosphorus	Potassium
	<i>Bu.</i>	<i>Lbs.</i>	<i>Lbs.</i>	<i>Lbs.</i>
Corn.....	60	54	8	11
Corn.....	50	45	7	9
Wheat.....	25	43	7	23
Oats.....	60	56	9	46
Total amount removed by crops		198	31	89

It is clear that the above system tends toward rapid soil depletion.

**The Balance Shown in a Grain Rotation.**—On the other hand, if a rotation like that mentioned in the Ohio trial were practiced, the following would represent the exchange of the elements on one acre during the four-year period (when the composition table in Chapter VI is used in computing).

*Exchange of Fertilizer Elements in Grain Rotation*

Crop	Removed				Added		
	Average yield	Nitrogen Lbs.	Phosphorus Lbs.	Potassium Lbs.		Nitrogen Lbs.	Phosphorus Lbs.
Corn.....	58.6 bu.	53	8	11	Acid Phosphate (700 lbs.) (7% P)	..	49
Soybeans....	19.0 bu.	..	7	24	.....	.....	.....
Wheat.....	28.7 bu.	34	6	7	Clover	113	..
Clover.....	2.75 tons	..	..	..	Soybeans*	8	..
Total for 4-year period.		87	21	42	Total added	121	49

\*The nineteen bushels of soybeans will carry about sixty-six pounds of nitrogen, and the straw about thirty-five pounds, or 101 pounds in the seed and straw. There is also some nitrogen to be accounted for in the roots and stubble, which, according to experiments, amounts to about one-tenth of the total amount in the whole soybean plant, or about ten pounds. In the soybeans on one acre there are contained, therefore, 111 pounds of nitrogen, of which two-thirds, or seventy-four pounds, are taken from the air. Since sixty-six pounds are sold in the grain, there are left eight pounds of gain per acre (all straw returned).

The balance in this case shows a gain per acre of about thirty-four pounds of nitrogen, twenty-eight pounds of phosphorus, and a loss of forty-two pounds of potassium for each rotation period.

The above system tends to increase soil fertility, as it has been demonstrated. The loss of ten and one-half pounds of potassium per acre is small, and can be easily restored, when necessary, by a little potash fertilizer. No account was taken of the leaching of nitrogen from the soil.

**Increase of Fertility on a Dairy Farm.**—The following represents the losses and gains of nitrogen and phosphorus on one acre on a dairy farm. A three-year rotation is practiced, manure is

applied at the rate of ten tons per acre once in three years, 300 pounds of acid phosphate per acre are applied with the manure for corn, and the second growth of clover is plowed under.

*Losses and Gains in Fertilizing Elements in a Dairy Farm Rotation*

Removed per Acre				Added per Acre		
Crop	Yields	Nitrogen Lbs.	Phosphorus Lbs.		Nitrogen Lbs.	Phosphorus Lbs.
Corn (silage)....	12 tons	82	16.5	Manure (10 tons)....	100.0	20.0
Oats.....	60 bu.	55.5	9.5	Acid Phosphate.....	..	21.0
				(7% P)		
Clover (red)....	2.5 tons	..	8.5	Clover (1 ton).....	41	..
Total.....		137.5	34.5	Total.....	141	41

The above system of stock farming tends to increase soil fertility.

**Loss and Gain of Plant-Food Elements Illustrated.**—In stock feeding, as in dairy farming especially, considerable feeds are usually purchased which help to offset the losses. Commercial fertilizers are often used. Cash crops are often raised. Moreover, considerable nitrogen may be leached from the soil. It is only when a farmer understands clearly how the fertilizing elements may be lost and the sources of gain, that he is able to direct his farming towards the maintenance of fertility. As it has been mentioned, the best way to determine this is to study the crop yields and to note the gain or loss of nitrogen and phosphorus, particularly.

The sources of loss and gain to the soil on the farm are illustrated in Figure 224.

**The losses by leaching** concern nitrogen, particularly. Experiments show wide differences in the amount of nitrogen lost in this manner. On grass lands and on cultivated fields of low fertility the annual loss per acre is slight; on cultivated fields of moderate fertility the loss is about twelve to twenty pounds per acre per year in regions having thirty inches of rainfall; and on cultivated fields heavily manured, or in a high state of fertility, the annual loss per acre may approximate forty pounds when the rainfall is heavy during July, or the middle of the growing period. The annual loss of nitrogen by leaching from uncropped or bare fields may exceed 150 pounds per acre.

**Losses in the feeding transaction** include the elements retained

by the animals for milk production, growth, etc., and the unavoidable losses sustained in handling the manure. When the manure is given the best care that can be given it under ordinary farm conditions, these losses may be estimated at forty per cent for nitrogen which is contained in the feeds fed, thirty per cent for the phosphorus, and about twenty per cent for the potassium. When the manure is left exposed to rains in an open yard even for three months, these losses may run as high as fifty-six per cent for nitrogen, forty-six for phosphorus, and seventy-one for potassium.

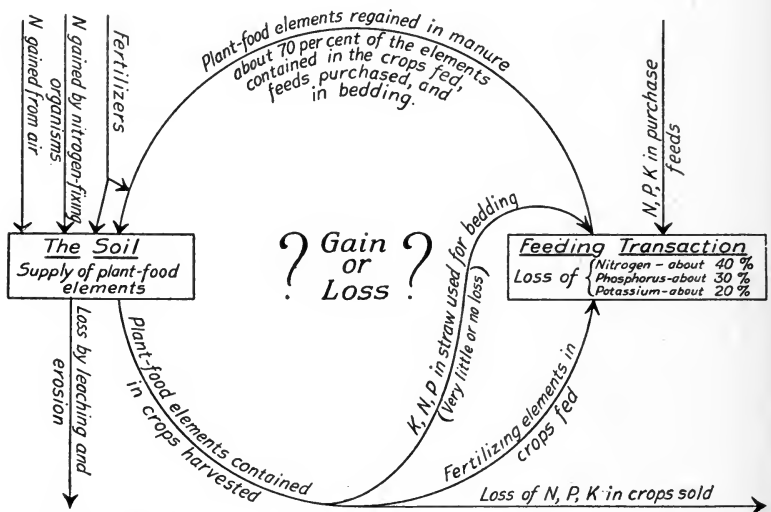

FIG. 224.—Diagram illustrating the sources of loss and gain of the fertilizing elements in farming.

In bedding no losses are to be considered except when manure is carelessly handled.

It is possible for a good stock farmer to return to the soil about seventy per cent of the fertilizing elements contained in the feeds fed and in the bedding.

Fertilizers may be applied directly to the soil or mixed with manure, as in case of phosphates.

When feeds are purchased the manure is enriched by an amount equal to the fertilizing elements contained in the feeds minus the losses in the feeding transaction.

**Summary of Losses and Gains.**—The sources of loss and gain



of the soil supply of the important plant-food elements may be briefly summarized as follows:

How losses occur:

- (a) In the sale of crops
- (b) In the feeding transaction.
- (c) Leaching from the soil—nitrogen particularly
- (d) Soil erosion

Sources of gain:

- (a) Feeds purchased
- (b) Fertilizers purchased
- (c) Nitrogen fixation, especially by legume bacteria<sup>7</sup>
- (d) Bedding purchased, particularly straw<sup>8</sup>

**Determining the Losses and Gains.**—When the manure produced is well cared for and all straw and other material like clover chaff and uneaten shredded corn stalks are passed into the manure as bedding, the approximate losses and gains of the plant-food elements, particularly nitrogen and phosphorus, may be ascertained. In constructing the balance sheet, the following rules should be observed:

1. The amount of nitrogen, phosphorus and potassium contained in any crop sold, except the nitrogen in legumes sold, is to be considered lost to the soil on the farm. (Consult the composition table, Chapter VI, and also the table on page 393, for the amount of the fertilizing elements contained in crops and feeds.)

2. Losses sustained in the feeding transaction may approximate forty per cent of the nitrogen, thirty per cent of the phosphorus, and twenty per cent of the potassium contained in the feeds used.

3. The nitrogen in clover and alfalfa hay sold is to be regarded neither loss nor gain to the soil.

4. Losses in pasturing may be considered as follows: Nitrogen, thirty per cent; phosphorus, fifty per cent, and potassium, twenty per cent. (Good pasture may be considered the equivalent to the production of one and one-quarter tons of mixed grass hay per acre.)

5. Loss in leaching may be considered at twelve to twenty pounds of nitrogen per acre per year on cultivated fields of moderately rich soil in humid regions, and about forty pounds per acre on heavily manured fields or on soils of very high fertility, and under heavy rainfall, especially during the middle of the growing period.

<sup>7</sup> A small amount of nitrogen is washed from the atmosphere as ammonia. This amounts to about five pounds per acre per year.

<sup>8</sup> Shavings possess little or no fertilizing value.

6. The fertilizing elements contained in purchased feeds fed minus the loss in feeding is to be regarded as gain to the soil.<sup>9</sup>

7. The nitrogen in clover, alfalfa and other legumes fed on the farm minus the loss in feeding is to be regarded as gain to the soil.

8. The nitrogen in clover, or other legume plowed under, is to be regarded as gain. (Estimate yields in terms of hay.)

9. The fertilizing elements contained in straw purchased for bedding are to be regarded as gain.

10. The fertilizing elements contained in fertilizers purchased are gain.

**The Nitrogen-Phosphorus Balance Sheet.**—The application of these rules can best be illustrated by the following problem:

On a dairy farm of 120 acres the following crops are grown:

Crops	Acres	Average Yield per Acre
Corn.....	25	12 tons silage, 65 bu. corn
Oats.....	25	50 bushels
Clover (medium red).....	15	2 tons (1 cutting)
Alfalfa.....	10	4½ tons (3 cuttings)
Pasture in rotation.....	25	Equivalent to 1¼ tons mixed grass hay per acre
Barley.....	10	30 bushels

All the milk produced is sold.

All crops harvested, except the barley, ten tons of clover hay and 250 bushels of oats, are fed on the farm.

Manure is hauled directly to the field or stored in a manure shed when it cannot be hauled directly to the fields.

Two hundred fifty bushels of oats and all the barley are sold.

Ten tons of clover hay (red clover) are sold.

Seventeen acres of corn are made into silage.

Eight acres of corn are shredded. About one-half the shredded stalks is used for bedding.

All straw is used for bedding.

The second growth of clover is plowed under (equivalent to one ton of hay per acre).

Ten tons each of wheat bran and gluten feed (high grade) are purchased and fed annually.

Three hundred pounds of acid phosphate (seven per cent phosphorus) are applied per acre to the corn land.

Determine the annual loss or gain of nitrogen and phosphorus in this system of farming.

<sup>9</sup> When the skim milk is fed on the farm it should be considered as purchased feeds, since the losses in the feeding transaction include milk production.

The balance sheet may be constructed as follows:

*The Nitrogen-Phosphorus Balance Sheet*

Crops, Feeds and Fertilizers	Nitrogen Balance Sheet		Phosphorus Balance Sheet	
	Loss of Nitrogen	Gain of Nitrogen	Loss of Phosphorus	Gain of Phosphorus
Corn silage (204 T.) (Rule 2)	555.0	....	84.5	....
Corn (520 bu.) (Rule 2).....	188.0	....	26.0	....
Shredded corn stalks (7 tons fed) (Rule 2).....	52.5	....	8.0	....
Oats (1,000 bu. fed) (Rule 2)	253.5	....	34.0	....
Oats (250 bu. sold) (Rule 1)..	158.5	....	28.0	....
Clover hay (20 tons fed) (Rules 7 and 2).....	....	492.0	20.5	....
Clover hay (10 tons sold) (Rules 3 and 1).....	....	....	34.0	....
Clover plowed under (15 T.) (Rule 8).....	....	615.0	....	....
Alfalfa hay (45 tons fed) (Rules 7 and 2).....	....	1285.0	63.5	....
Pasture (Rule 4).....	229.0	....	49.0	....
Barley (300 bu. sold) (Rule 1).	265.0	....	53.0	....
Wheat bran (10 tons fed) (Rule 6).....	....	307.0	....	180.0
Gluten feed (10 tons fed) (Rule 6).....	....	487.0	....	38.0
Acid phosphate (7500 lbs.) (Rule 10).....	....	....	....	525.0
Leaching (corn land) (Rule 5).	300.0	....	....	....
Totals.....	2001.5	3186.0	400.5	743.0
Net loss or gain.....	....	1184.5	....	342.5

This system of farming tends towards soil enrichment and the increasing of soil fertility. The crops grown also indicate this tendency.

The potassium balance sheet may be worked out in a similar manner as that for phosphorus.

**Conclusions.**—Good farming may be either stock farming or grain farming. It is possible to increase and maintain soil fertility under either system. The crop yields and the nitrogen-phosphorus balance sheet in any rational system of farming may indicate whether the system tends towards soil depletion or soil enrichment.

**Fertility Surveys.**—Make surveys of a number of farms of the region including farms of different types. Obtain data to calculate the amounts of plant-food elements removed by the chief crops and also the amounts returned in green manure, barnyard manure, etc. Make comparative studies of these data and determine what types of farming are best for maintaining the soil fertility.

**Home Projects** in maintaining the soil fertility with any of the permanent lines of farming may be started.

## QUESTIONS

1. What is the important problem in agriculture? Why?
2. Name and describe briefly the different systems of farming.
3. What is the importance of grain farming?
4. What has been the result of grain farming in the past? Illustrate.
5. How is it possible, even in grain farming, to maintain and increase soil productivity? Give an illustration.
6. Why is livestock farming popular?
7. What are the probabilities of maintaining soil fertility by livestock farming?
8. What comparisons have been made between livestock farming and grain farming? Describe these tests briefly and give results.
9. What are the advantages to be gained in combining stock raising with grain growing?
10. Aside from crop yields, what may indicate good farming as regards soil fertility? How can this be determined on different fields?
11. Explain and illustrate by aid of a diagram the sources of loss and gain of the fertilizing elements in farming.
12. Summarize the sources of loss and gain of the soil supply of plant-food elements in farming.
13. How may the losses and gains be determined in the following cases:
  - (a) When corn or barley is sold.
  - (b) When clover or alfalfa hay is sold.
  - (c) When alfalfa hay is purchased and fed.
  - (d) When soybean seed is sold.
  - (e) When straw is purchased for bedding.
  - (f) When corn silage is produced and fed on the farm.
  - (g) When commercial fertilizers are applied to the soil.
  - (h) Leaching from the soil.
  - (i) When a crop of green clover is plowed under for soil improvement.
  - (j) When the straw produced is used for bedding.
  - (k) When stock is pastured.
  - (l) When concentrates are purchased and fed.
  - (m) When clover hay is produced and fed on the farm.
14. Give the important conclusions of this chapter.

## PROBLEMS

1. When the manure is well cared for, how many tons of wheat bran or cotton-seed meal must be fed to offset the loss of phosphorus in feeding twenty tons of alfalfa and sixty-five tons of corn silage?

2. Assuming good care in handling the manure, construct a nitrogen-phosphorus balance sheet for a farm on which all the crops, except cabbage, are fed—as follows: No feeds are purchased; 250 tons of corn silage are fed (all corn made into silage); sixty tons of clover hay (medium red); six tons of oat straw are fed, the remainder is used for bedding; 1000 bushels of oats; thirty acres of pasture equivalent to 0.8 ton of mixed grass hay per acre; eighty tons of cabbage are sold. (a) How many pounds of acid phosphate carrying sixteen per cent phosphoric acid ( $P_2O_5$ ) must be used to offset the loss of phosphorus? (b) How many pounds of rock phosphate analyzing 13.5 per cent phosphorus?

3. Suppose on a stock farm the following crops were fed: Twenty acres of corn yielding twelve tons of silage per acre, forty acres of medium red clover, yielding two tons of hay per acre, and 19.2 acres of oats averaging fifty bushels per acre (all straw used for bedding). Ten tons of gluten feed (high grade) were purchased and fed. Assuming good care in handling the manure, what per cent of the fertilizing elements contained in the crops and purchased feed may be regained in the manure?

## CHAPTER XXII

### HOW THE NEEDS OF SOILS MAY BE DETERMINED

**Chemical Analysis Has Limitations.**—At first thought it would seem that since the requirements of the different crops are known, the fertilizer needs of any particular soil can be determined simply by a chemical analysis of that soil. This, however, is not the case, because several factors must be considered in addition to the quantity of the plant-food elements contained in the soil—such as, the plant characteristics, the kind of soil, availability of the elements, and all the other factors which determine fertility.

What might be the fertilizer needs of a particular soil which analyzes 0.3 per cent nitrogen, 0.08 per cent phosphorus, 1.3 per cent potassium, and is not acid?<sup>1</sup> No one can tell with any degree of certainty without considering carefully all the factors named and to which reference is made (p. 80). It is evident, therefore, that the chemical analysis of a soil has certain limitations. It is not to be understood, however, that chemical soil analyses are of no value. Because of these limitations, other methods than determining the total amounts of nitrogen, phosphorus, and potassium in soils have been devised to ascertain the fertilizer needs or the cropping possibilities of soils; such as, availability tests, pot tests made in the greenhouse, cylinder tests made indoors or out of doors, and fertilizer tests made on the farm under field conditions.

**Other Factors First.**—Before deciding upon a chemical analysis to solve a soil fertility problem, the following factors should be considered:

(a) *Drainage.*—Very often crop yields are low, or some crop fails entirely, because of the lack of proper underdrainage, even though the soil may be rich in all the elements. This factor should be considered on sloping fields, on hillsides and at the foot of slopes or hills as well as on lowlands (Fig. 46, Chapter IX).

(b) *Moisture Supply.*—Frequently the lack of sufficient moisture, even in humid climates, is the cause of low yields. This lack of moisture may be the result of insufficient rainfall during

---

<sup>1</sup> This particular soil responded well to acid phosphate and potash in the field.

the growing period, and especially because of gravel or coarse sand subsoils (Fig. 42).

(c) *Physical Condition of the Soil*.—Since there is a close relationship between the physical condition of a soil and its fertility, attention should also be given this factor in diagnosing infertility or the cause of low yields. A striking difference in growth of plants due to physical improvement of the soil is shown in Figure 225. Cultivation improved the poor growth as shown by Figure 226.

(d) *Inoculation*.—In determining the cause of failures or unsatisfactory crops in growing any legume, especially for the first time, it is important to determine whether or not the soil is properly inoculated. This can best be done by digging up several plants with a spade and examining the roots for nodules. If none are found and the soil is not acid, the lack of proper organisms must necessarily be the limiting factor, provided, of course, other conditions are favorable. If the soil is acid, liming is the first aid, then inoculation (see index).

(e) *Harmful Agents in the Soil*.—Not only should injury from diseases like rust, barley stripe and blight, and from insects like leaf aphids, boll-weevil and beetles be considered, but also the harmful agents which may infest the soil. These may be diseases, insect pests, certain poisonous substances, etc. (Chapter XIV).

(f) *Organic Matter*.—Organic matter (see index) in soils affects practically all the factors which determine fertility. It is important, therefore, to note the amount of organic matter in any soil under examination, especially upland soils. The color of the soil usually indicates the amount present.

#### CHEMICAL ANALYSES AND THEIR VALUE

**Total vs. Available Plant-food Elements**.—Chemical analysis which shows the total quantity of the important plant-food elements contained in a soil is not always an index to its productiveness, because it is not so much the total supply as it is the amount that is available, or which can easily become available to meet the needs of the crop, that determines the productivity of the soil. When this fact became established, chemists tried to discover some method to measure the availability of the elements, or ascertain to what extent the crop can secure its requirements from any particular soil. Attempts, therefore, have been made to imitate the action of the plant roots in securing the elements,



FIG. 225.—Not a fertilizer test—only a difference in plowing. To left, clover sod was fall plowed as in Figure 75. To right, same kind of plowing but done in the spring. To left, nitrification was retarded. (See Fig. 226.)



FIG. 226.—Proper cultivation overcame conditions shown in Figure 225. No difference in yield at harvest time.

but little progress has been made. Some of these methods, however, have come nearer than the total analysis in ascertaining the cropping possibilities of a soil, or in determining its fertilizer needs.

**Uses for Chemical Analysis.**—Soil fertility investigators and field men usually prefer to know the chemical composition of the soils on which they work. In this respect, chemical analyses are of great value, especially in continued experiments, in studying the effect that certain methods of fertilization and cropping have upon the chemical properties of a soil, or upon the supply of the plant-food elements.

In soil survey, chemical analyses are especially valuable in comparing soil types and in tracing any correlation between the chemical and physical properties of certain types.

Frequently, farmers desire chemical analyses of soils in order to determine their quality as compared with other soils.

Four things are commonly determined by chemical analyses, namely: (a) the need of lime; (b) the supply of nitrogen and organic matter; (c) the phosphorus supply, and (d) the potassium content.<sup>2</sup>

**Testing Soil for Its Need of Lime.**—Since an acid soil is detrimental to economic crop production, testing a soil for acidity or for its need of lime is of primary importance. Some farmers have limed certain soils because they thought they were acid, when, later on, tests showed that no lime was needed. This represents a typical case of wasted energy and money because of guesswork. Many farmers have failed again and again trying to grow alfalfa on acid soils, all because they did not consider the necessity of determining beforehand whether or not the soils were adequately supplied with lime. Again, many farmers do not know whether it would be best to lime their soils or not. Simple acidity tests can answer such questions definitely (p. 234).

---

<sup>2</sup> Trustworthy samples for full chemical analyses should be collected by trained men. A soil auger is commonly used in getting the samples. At least ten different borings from different parts of the field examined should constitute the sample to be taken into the laboratory. Samples of the surface soil are usually taken to depths of six and two-thirds to eight inches. The subsoil should be examined to a depth of at least three to four feet for texture, structure, permeability to water, etc. For practical purposes it is not necessary to make chemical analyses of subsoils.

When the soil sample reaches the chemical laboratory, it is air-dried, screened of its stones, coarse gravel, etc., thoroughly mixed and finely pulverized.



**Nitrogen and Organic Matter.**—Nitrogen is an index to the supply of organic matter. When the percentage of nitrogen is high, the organic matter is abundant; when very low, the need of organic matter becomes evident. Many highly productive silt loams, for example, contain 0.25 per cent and more of nitrogen, while many others, particularly the lighter-colored types, contain about 0.15 per cent. Frequently the nitrogen content of certain long-cropped silt loams is as low as 0.09 per cent. Such a low percentage, together with field observations, generally indicates the urgent need of more nitrogen and organic matter. Thus, special manuring may be recommended, the plowing under of some legume as a green manuring crop, and the growing of more and better clover. Whenever possible, it is instructive to compare the nitrogen content and organic matter of any long-cropped soil with a virgin sample of the same soil collected along the fence. Such comparisons usually support the reasons commonly given why crop yields are much less now than in former years.

**Phosphorus determinations** are not only interesting but of much value, since this element is regarded by many as the key to the maintenance of soil fertility. Highly productive silt loams commonly analyze 0.09 to 0.12 per cent, or more, of phosphorus. Some long-cropped silt loams contain no more than 0.03 per cent. Practically all low determinations of phosphorus indicate the need of phosphate fertilizers. When examining into the phosphate needs of any particular soil, it is also important to take into consideration soil acidity, the fertility factors, the cropping history of the fields, and the character of the crops grown.

Some silt loams, for example, are comparatively well supplied with phosphorus, as high as 0.08 per cent, but because they are deficient in active organic matter, or because of poor aëration, they respond to soluble phosphate fertilizers (Fig. 126). Again, most acid, black silt loams are in need of phosphates even though they may contain fairly good supplies of phosphorus (see index) (Fig. 137).

It is important to know that certain soils are well supplied with phosphorus, because this fact will decide whether it is necessary to rely wholly upon commercial fertilizers for the source of phosphorus, or to adopt such measures as to render available the phosphorus already present in the soil. During the improvement of such soils by the addition of organic matter and by liming, it is usually necessary to supply available phosphorus in the form

of acid phosphate or bone meal. Later on rock phosphate may be used.

Phosphorus determinations of ordinary sands, mucks and peats are valuable in ascertaining the quality of these soils.

If any one doubts that a soil can ever become depleted by exhaustive cropping, let him compare the phosphorus analyses of long-cropped and depleted lands with those of virgin soils of the same kinds, or of similar soils that have had their phosphorus supplies maintained or increased through good farming methods. No arguments are so convincing.

**Potassium Analyses.**—On many soils, especially the heavier types, potassium determinations are important largely because of their inventory value. On other soils analyses show surprisingly low supplies of this element, particularly in case of peats. Usually, when a soil is found to contain a low amount of potassium, potash fertilizers are required. Soils abundantly supplied should be so managed as to enable them to render available sufficient amounts to meet the needs of crops (see "Potash" in index).

#### POT TESTS

**Pot Tests Not Fully Reliable.**—It has been the hope of chemists to determine by pot tests what chemical analyses do not or can not show as regards the fertilizer needs of a soil or its cropping possibilities. This method consists in filling several jars or cylinders with the soil to be studied, treating the pots in different ways, and growing a crop to indicate the proper treatment (Fig. 192).

This method seems most reasonable and sure. Moreover, it can be carried on under absolute control as regards moisture and temperature conditions. The results of some pot tests are of special value in determining the fertilizer needs of any particular soil and serve to reinforce field observations and chemical analyses (Figs. 135 and 136). In general, however, such results can not be fully relied upon as guides in the practical operations of the farm, because it is impossible in such tests to reproduce the natural conditions found in the field.<sup>3</sup>

#### FIELD OR PLOT TESTS

**Field Tests Are Best.**—Fertilizer tests made on the farm, or on the land in continued plot experiments, are the most reliable.

<sup>3</sup> Tests made in large cylinders usually extend over several years. It is not practicable to make pot tests on the farm.

1.	No treatment
2	Acid phosphate
3	Muriate of potash
4	No treatment
5	Nitrate of soda
6	Acid phosphate and nitrate of soda
7	No treatment
8	Acid phosphate and muriate of potash
9	Muriate of potash and nitrate of soda
10	No treatment
11	Acid phosphate, potash, and nitrate of soda
12	Acid phosphate, potash, and nitrate of soda
13	No treatment
14	Phosphate, potash and nitrate of soda to corn and wheat
15	" " " " " " wheat
16	No treatment
17	Same as 11 but more phosphate and less nitrates
18	Manure, 8 tons on corn and wheat
19	No treatment
20	Manure, 4 tons on corn and wheat
21	Same as 17, but nitrogen in oilmeal
22	No treatment
23	Same as 17, but nitrogen in dried blood
24	Same as 17, but nitrogen in sulphate ammonia
25	No treatment
26	Same as 11, but phosphorus in bonemeal
27	Same as 17, but nitrogen in nitrate of lime
28	No treatment
29	Same as 11, but phosphorus in basic slag
30	Same as 17, but nitrogen in tankage

Lime.

No lime.

FIG. 227.—A series of experimental plots. (Ohio Station.) (See Fig. 229.)

In scientific studies, it is necessary to extend the tests over many years before accurate results can be obtained regarding the proper soil treatments and the maintenance of fertility. Such scientific work is much more difficult than ordinary chemical analysis or pot tests.

**How Experiment Stations Conduct Tests.**—Nearly all of the Agricultural Experiment Stations are conducting field tests, some of which are very extensive. The size of the individual plots is



FIG. 228.—A small plot left unlimed as a check.

usually one-tenth of an acre, each carefully measured and permanently staked. Figure 227, representing one of the many series of plot tests established by the Ohio Station, illustrates how this work is done.

This particular group of plots represents block D in Range IX on the east side of the Central Farm at Wooster, Ohio. Block D is one of five in an experiment begun in 1893, to determine the effect of fertilizers and lime

on corn, oats, wheat, clover and timothy in a five-year rotation. It is to be observed that each block consists of thirty plots, each sixteen feet wide and sixteen and one-half rods long. The soil treatments are indicated in the diagram. The west half of each block, or of each plot, is limed, while the east half is left unlimed. The results are secured by harvesting the crop on each plot separately. The yields are carefully determined and recorded (Fig. 229).

**How Farmers Can Conduct Field Tests.**—The farmer is a busy man and therefore has not the time to devote to much experimental work. That is the business of the Agricultural Experiment Stations. But the Experiment Station can not do



FIG. 229.—Block D in clover, consisting of thirty one-tenth acre plots. Block E, in foreground, in wheat. Left half limed. Right half unlimed. (Ohio Station.)

everything. The best it can do on soil problems is to establish certain fundamental principles that may be applied generally. The simpler problems and those which have to do with the soils on individual farms are left to the leading farmers to work out either for themselves, or under the direction and supervision of the Experiment Station, the College of Agriculture, or of the County Agricultural Representative. Such tests can be made simple, and need not interfere in any way with the farmers' plans. A few illustrations follow:

*Testing the Value of Agricultural Lime.*—Even though the Experiment Stations have proved the value of liming acid soils,

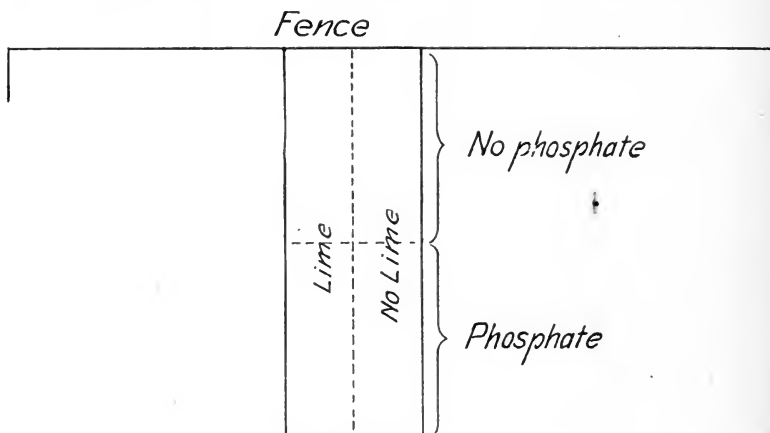

FIG. 230.—How to demonstrate the value of lime and acid phosphate. (See page 232.)

it is important to continue to demonstrate the value of agricultural lime on individual farms and on different soils. Such tests are valuable, not only from an educational point of view, but, when rightly conducted, afford the farmer a basis for figuring the increases in net returns from this method of soil improvement.

When an entire field is to be limed, an acre strip, or a one-half or a one-fourth acre area, may be left unlimed (Fig. 228). When only a small area is to be limed as a trial, the limed strip may extend through a field or project into it; or a portion of a field may be limed. Both limed and unlimed areas should be cropped the same, the same quality of seed used, and the lots should receive like treatment, except for the lime (Figs. 229 and 230).

*Trying Fertilizers.*—In trying fertilizers, it is comparatively

easy to fertilize a strip through the center of a field, or to leave an unfertilized area for comparison. When fertilizers are used in the drill for corn, for example, a few rows could be left unfertilized (Figs. 133 and 137).

Sometimes the problem is to determine the proper combination of fertilizers or which are the best to use. It then becomes necessary to make a more elaborate test. Figure 225 represents a

<i>Muriate of potash, 200 lbs. per acre</i>	<i>A</i>
<i>Muriate of potash, 200 lbs. per acre Acid phosphate, 400 lbs. per acre</i>	<i>B</i>
<i>No treatment (check)</i>	<i>C</i>
<i>Muriate of potash, 200 lbs. per acre Rock phosphate, 800 lbs. per acre</i>	<i>D</i>
<i>Manure, 25 tons per acre</i>	<i>E</i>

FIG. 231.—Diagram of a manure and fertilizer test made on a marsh soil. (See Figs. 132, 232, and 233.)

test made on a marsh area in Wisconsin. Four different treatments were compared. Each strip represents one-quarter of an acre. Figure 226 shows the results secured on plots A and B. Figures 232 and 233 combined, compare the results of B with no treatment C. Figure 233 shows the results on plots C and D; and Figure 132 shows the results on D and E.

Similar tests may be made on sands and on other upland soils. When the soils are acid, one-half of each fertilized plot or a portion of each end, should be limed, so that results may be secured both with and without lime.

**Points to Observe.**—In making liming tests, best contrasts in results can be secured when a definite line is made between the “limed” and “no lime” areas. To accomplish this, the west portion of a field should be limed when the wind blows from the east, or the east portion when the wind blows from the west. When the limed plot extends through a field, the windward border of the plot, at the time the lime is applied, should be selected for the best contrasts. The same point should be observed in applying certain fertilizers broadcast.

Sometimes when two or more adjacent plots are to be fertilized differently, it becomes necessary to mix certain of the fertilizers



FIG. 232.—Potash alone compared with potash and acid phosphate. (Wisconsin Station.)

with moist soil to prevent the wind from blowing the fertilizer over the other plots. In such tests it is usually best to apply the fertilizers by hand, and then mix them thoroughly with the soil by disking or “dragging.”

Avoid the laying out of test plots adjoining and parallel to fences. Extend them into or through the field away from fences. Long strips are better than square plots.

Observing the difference in growth on the various plots is not sufficient in determining the final and comparative results. It is always best to obtain the results by weighing the whole crop and determining the actual yields. When it is not convenient to harvest each plot separately, the crop on an average square rod on each plot may be properly harvested, and results calculated to acre basis.





Fig. 233.—Results secured on plots C and D, Figure 231. (Wisconsin Station.)

## FARM EXAMINATIONS

**Farm Visits Are Essential.**—Whenever a farmer wishes definite information concerning the needs of his soil, drainage, crop rotation, etc., it is most satisfactory, if such provision is made, for a representative to visit the farm. In this way a soil fertility expert is able to consider all conditions, note the character of the subsoil, observe the growing crops if circumstances permit, obtain the cropping history of each field if necessary, and if he thinks it important, take samples of soil for chemical analyses. The farmer should receive a report with recommendations for soil improvement. When several farmers in a community become interested in such farm examinations it is often advisable to “follow up” or reinforce such work with field demonstrations.

**Field demonstrations** may be conducted as home projects to determine the values of each of the methods of soil improvement which are considered profitable. These may include projects in liming, inoculation, green-manuring, use of barnyard manure, use of commercial fertilizers, drainage, irrigation, subsoiling, dry farming methods, mulching, etc. In each trial check plots should be left for contrast. This will make the trials more conclusive.

Consult chapters XII and XIII.

## QUESTIONS

1. Can the fertilizer needs of a soil or its cropping possibilities be determined by chemical analysis? Explain.
2. What other methods have been devised to answer these questions?
3. Name and discuss the conditions which should be considered before deciding upon chemical analysis for the solution of a soil fertility problem.
4. State specifically how organic matter in soils affects the fertility factors.
5. Why were methods of chemical analysis devised to determine the availability of the elements? What success has been attained?
6. In general, mention some benefits to be derived in determining the total amount of each of the important elements contained in soils.
7. For practical purposes, what analyses are commonly made? Discuss the value of each determination.
8. Discuss the results secured in pot tests in relation to practical operations of the farm.
9. How are pot tests usually made?
10. What is the best method whereby the fertilizer needs of soils may be determined and principles governing fertility maintenance established?
11. How do experiment stations conduct such tests?
12. Explain how farmers can conduct simple lime and fertilizer tests.
13. Mention some points to be observed in making these tests.
14. Discuss the advantages in having the soils examined on the farm by a soil fertility expert.

## CHAPTER XXIII

### PROFITABLE CROP PRODUCTION

**Large Crops Not Necessarily the Most Profitable.**—It is commonly assumed by farmers that large crop yields per acre are the most profitable, and that he who raises the most per acre makes the most money. This may or may not be true. High yields per acre are profitable when consistent with low cost per unit of produce. Low-priced land, rich, virgin soil, favorable seasons and cheap labor are important factors which lend to such possibilities; but ordinarily the general principle is that the higher the yield on a given soil, the greater the cost per acre. The product per dollar of expense will usually increase up to a certain point as a result of increased expenditures per acre, but a point is certain to be reached with continued increase of expenditures when the returns per dollar will be less and less.

On high-priced land excessively fertilized a yield of 120 bushels of shelled corn per acre may be just as unprofitable as a yield of twenty-six bushels on land never fertilized. In the first case, expensive and excessive fertilizers may swallow all profits, while in the second case the yield may not be sufficient to pay for the labor and machinery costs.

**Profitable Crop Production Is the Foundation of Successful Farming.**—It is very necessary, therefore, for every farmer, if he wishes to put his farming on a money-making basis, to produce a large enough yield to cover all production costs and have net profits besides. The net profits per acre, of course, should be as large as possible if the change in method does not reduce the number of acres the farmer can raise. Increasing the yield on a given soil also means increasing the expenses per acre in producing the crop, though at the same time the profits may be increased. Doubling the yield may not necessarily mean doubling the profits; but, on the contrary, it may reduce the profits. It is not so much a question of *maximum yields*, therefore, as it is a question of *maximum profits* in crop production which, in a large measure, determines successful farming.

**Profits Determine Fertilizer Practice.**—In fertilizer practice and in soil improvement, the question arises, "Does it increase

the farm profits?" Few farmers, indeed, could be induced to use fertilizers and agricultural lime were no profits forthcoming. It is quite evident that when crop increases are profitably obtained by improving the soil through fertilization and otherwise, the farm profits, or managerial income,<sup>1</sup> should likewise be larger. Much, of course, depends upon the manner in which the crops are disposed of. This explains why soil fertility investigators extend their investigations into farm management just so far as to enable them to arrive at their conclusions by determining the "value of crop increases above cost of fertilizers."

Commercial fertilizers are profitable when they are judiciously used. The fertilizer practices in the Eastern and Southern states, as well as in the countries of the Old World, are sufficient evidence of this fact.

**The Crop-production Problem.**—A most vital problem which confronts the land owner in his farm management is to determine the point at which his crop yields are the most profitable. To do this he must consider such factors as the value of his land,<sup>2</sup> the cost of labor, machinery cost, cost of fertilizers and the price he expects to receive for his produce. In such determinations the cost of fertilizers is an important factor, because the fertilizers may be largely responsible for high yields and at the same time lower, or even consume the profits, if excessively or unwisely used.

In a certain corn contest a boy won the prize because he produced the greatest number of bushels per acre. However, when the total cost was considered, the value of the crop at market price was not sufficient to cover the cost. The largest item was the cost of the fertilizer treatments—he fertilized excessively.

**The Value of a Plot Left Untreated.**—The actual profits derived through the use of commercial fertilizers on the farm are too frequently matters of guesswork. A check on increases due to fertilizers may be secured by comparing fertilized plots with a plot left unfertilized. It is just as important that leading farmers establish test plots on the farm to determine economic crop production as it is for experiment stations to do so—the only difference

---

<sup>1</sup> Managerial or labor income means farm profits above total costs; total costs including unpaid family labor and interest on total investment. Family labor means all work done by wife and children on the farm, not including the household.

<sup>2</sup> Land rental is an expense considered in crop production. When the land is owned by the farmer it is usual to charge five per cent on the value of the land in lieu of rent.

being the farmer's system should be much more simple (Chapter XXI).

**Determining Profits From Fertilizers.**—The almost universal method of interpreting fertilizer tests is to subtract the cost of fertilizer from the increased value of the crop. If the value of the increase is greater than the cost of the fertilizer, the fertilizer is considered profitable. Authorities on farm management and agricultural economics criticise this method because all the other costs, such as interest, hauling and applying fertilizers, and harvesting, storing and marketing the increased crop, are disregarded.<sup>3</sup> All authorities would not count interest on "materials in process," such as fertilizers and feeds.

Since profits determine fertilizer practice, it is quite necessary to give business interpretation of results of fertilizer tests. Net value of the crop increase, therefore, should determine the conclusions regarding profits from fertilizers. A check plot is necessary to obtain the increased value of the crop. The value of the increase minus the increased cost for fertilizer and additional labor, etc., gives the net value of the increase. In all liberal fertilization it is usually best to obtain the net value of the increases for the rotation rather than for one year only.

When the increase in yield gives only a small margin above the mere fertilizer cost, the chances are the cost of application and other increased costs would cancel this margin.

*An Example.*—On a soil deficient in available phosphorus, a farmer applied 300 pounds of acid phosphate per acre for oats in a three-year rotation of oats, clover and corn. A plot was left unfertilized for a check. The increases per acre in three years were seventeen bushels of oats, one-half ton of clover hay and ten bushels of corn, the total valued at \$22.50 (including straw and stover). The cost of fertilizer, interest, application and all other costs to harvest and care for the increase was calculated to approximate \$9.00 for the three years. In this case \$13.50 is the net value of the increase per acre. These results clearly show that acid phosphate was profitable.

**Determining the Most Profitable Fertilizer.**—Frequently on lands in need of fertilizers, it becomes necessary to determine by field tests which of two or more fertilizers, combinations of fertilizers or different amounts applied is the most profitable. The net

---

<sup>3</sup> Warren, Farm Management.

value of the increased yield for each fertilizer treatment must necessarily be obtained in a similar manner as described in the foregoing paragraphs.

**Basis of Computing Returns.**—The following questions now arise: “Upon what basis should the profits be computed? Should the profits be expressed in terms of *per cent of the cost of the fertilizer*, or should they be expressed in terms of *net profits per acre*?”

In all farm accounting, the cost of fertilizer is considered an expense and is charged against the crop. To be consistent, this expense should not be considered as capital permanently invested.

The two main benefits derived through proper fertilization are: (a) the productivity of the soil is increased, and (b) the soil reserve of some of the important elements of plant-food is increased or maintained. These benefits result in an “appreciation” which is an increase in the value of the land.

Moreover, expressing profits in terms of per cent on money paid out, or invested, is deceiving. Some business men have gone into bankruptcy because they relied too much upon what per cent seemed to show. In business administration it is recognized that actual profits above total costs determine which of two investments or business ventures, for example, is the more profitable.

*An Example.*—“A” gained a net profit of 400 per cent on money he invested. “B” gained a net profit of ten per cent. This does not necessarily mean that “A” made the more profitable investment. “A” had one dollar of ready money and invested it in popcorn, and in so doing gained a net profit of four dollars. “B,” on the other hand, did not have any ready money, but seeing an opportunity to make a safe investment, he borrowed ten thousand dollars at six per cent interest for one year. He made the investment, “turned” the property within the year, and received eleven thousand six hundred dollars. He returned the ten thousand dollars which he borrowed, paid six hundred dollars interest, and had one thousand dollars left as profit. It would be needless to say that “B” made the more profitable investment.

**Acres Profits.**—As regards crop production, farmers and land owners think in terms of acres, and they plan to secure the most profits per acre. Ordinarily when they fertilize, they hope to increase these profits even though the cost of producing the crop is augmented. Any fertilizer treatment, therefore, which gives the greatest value of crop increases above the fertilizer and other increased cost per acre will usually be the most profitable.

*An Illustration.*—On a certain soil two different fertilizers were tried—the applications being made once in a three-year rotation. The following are the three-year results concerning profits:

Fertilizers	Cost per acre	Net value of increase per acre per rotation	Per cent profit on cost of fertilizer
A	\$4.00	\$15.00	375
B	8.00	21.60	270

It is to be noted that the fertilizer "A" gave a net return of \$15.00 per acre, or 375 per cent profit on the cost of fertilizer; and "B" gave a net return of \$21.60 per acre, which is 270 per cent profit on the cost of the fertilizer. The fertilizer which gave a net profit of 270 per cent returned \$6.60 more per acre than the fertilizer which gave a net return of 375 per cent on cost of fertilizer.

Suppose a man had fifty acres of similar land and had only \$200 of ready money to expend for fertilizers. He would be a poor business man, indeed, if he could not see that if he borrowed \$200 one year to enable him to fertilize every acre with fertilizer "B," he could realize \$330 more net profits, and in so doing realize at least 165 per cent profit on the money borrowed.

When such conditions prevail as regards the use of fertilizers the land owner must first determine whether or not the change in method of crop production will reduce the number of acres he can raise, since the goal in profitable farming is "greatest amount of profits per man." If the method of fertilization does not reduce the number of acres of crop he can raise under his system of farming, then both fertilizers (A and B) would be profitable—and the one which gives the greater net profits (dollars) per acre is the more profitable.

**Proper Kind and Amount of Fertilizers.**—Two important factors come into play in determining the profitable use of commercial fertilizers, namely, the proper kind of fertilizers and the right amounts that should be used. These two factors may be expressed in terms of two economic laws, as follows: The "law of the minimum" and the "law of diminishing returns."

**The law of the minimum** as related to fertilizers and crop production may be stated as follows: *If the soil is deficient in one particular element of plant-food, the yield of a given crop will be limited by the amount of that particular element contained in the*

*fertilizer added.* For example, if a soil contains an abundant and available supply of all the plant-food elements except phosphorus, and all other factors and conditions are favorable, the yield, in a large measure, will be proportional to the amount of available phosphorus added in the fertilizer. No excess of the other elements will make up for the shortage of phosphorus (Chap. VII, Fig. 33).

**The law of diminishing returns** as it is applied to fertilizers may be stated as follows: *The first expenditure of a proper or needed fertilizer is usually the most effective. Each additional increase in application produces smaller and smaller returns, until a further increase causes no increase in the yield.*

This is well illustrated by an experiment on wheat, begun in 1852, at Rothamsted, England, the oldest experiment station in the world. Several adjoining plots received mineral fertilizers such as phosphates and potash, in greater amounts than were removed by the crops. In addition to the mineral fertilizers, a nitrogen fertilizer was applied in different amounts. One plot received no nitrogen fertilizer, another 200 pounds per acre, a third 400 pounds, a fourth 600 pounds, and a fifth 800 pounds per acre.<sup>4</sup> The fertilizers were applied every year and each year wheat was grown. At the end of the thirteenth year the following average results were secured:

*Diminishing Returns from Nitrogen*

Treatments per Acre	Average Yield for 13 years	Increase	Increase per 200 lbs. Nitrogen Fertilizer
	<i>Bu.</i>	<i>Bu.</i>	<i>Bu.</i>
Mineral fertilizers but no nitrogen . .	18.3	..	..
Mineral fertilizers + 200 lbs. nitrogen fertilizer . . . . .	28.6	10.3	10.3
Mineral fertilizers + 400 lbs. nitrogen fertilizer . . . . .	37.1	18.8	8.5
Mineral fertilizers + 600 lbs. nitrogen fertilizer . . . . .	39.0	20.7	1.9
Mineral fertilizers + 800 lbs. nitrogen fertilizer . . . . .	39.5	21.2	0.5

The fourth column shows that the first 200-pound application of the nitrogen fertilizer returned 10.3 bushels. Increasing the application by 200 pounds caused an additional increase of 8.5

<sup>4</sup> Equal parts of ammonium sulfate and ammonium chloride. The Book of the Rothamsted Experiments, 1917, pages 34 and 46. The experiment is still being continued.



bushels. The third 200-pound increase returned 1.9 bushels, and the fourth 200-pound increase of the nitrogen fertilizer returned only one-half a bushel. These results clearly show that increasing the application of a needed fertilizer does not necessarily mean a corresponding increase in the yield. Doubling or trebling the application does not necessarily mean doubling or trebling the increase.

The relation between cost of production and profits may be shown by the diagram in Figure 234, which indicates the profits in

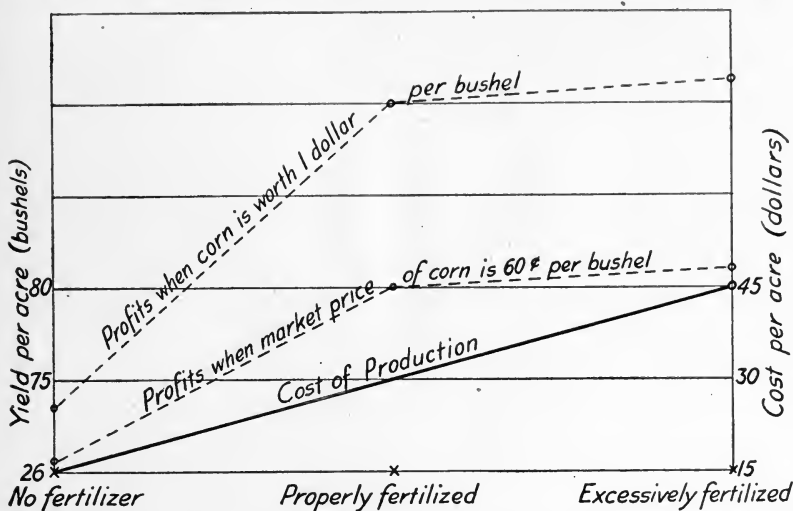

FIG. 234.—Diagram showing the relation between cost of production and profits.

corn production on poor land without fertilization, when properly fertilized, and when excessively fertilized. It is to be noted that when the market value of the crop is high, the profits per acre are much greater than when prices are low. Ordinarily, the greatest net profits per acre can be realized when the soil is properly fertilized, and when high crop prices prevail.

**Summary.**—Successful farming is determined in a large measure by maximum profits in crop production and not necessarily by maximum yields. High yields may not always mean large profits. Doubling the yield may not mean doubling the profits. The use of fertilizers has a direct bearing upon the net profits to be secured in growing crops. The value of the crop increase per acre above

cost of fertilizer and other increased costs should be the basis for determining profits from fertilizers. When the use of fertilizer does not reduce the number of acres operated per man, the profits per acre above fertilizer and other increased cost per acre determine profitable fertilizer practice. When two or more fertilizers are found profitable on the same soil, the most profitable is the one which gives the greatest amount of net profits per acre. The greatest net profits per acre are obtained when the fertilizer needs of the soil are properly met and high crop prices prevail.

**Home projects in fertilizing** should be started by students and farmers. Common local crops should be grown with and without the fertilizers containing the elements which those crops remove from soils. A number of strips may be grown on which the fertilizers differ in amount and kind. Keep records of the cost and yield and determine the net profit per acre in each case.

### QUESTIONS

1. Are large crop yields per acre the most profitable? Explain.
2. Discuss the relation of profitable crop production to successful farming.
3. What determines fertilizer practice? Discuss.
4. Why is it not necessary for soil fertility investigators to determine the effect that soil improvement measures have upon managerial income?
5. What is meant by managerial income? Land rental?
6. What is a most important problem which confronts the farmer as regards his farm profits? How may this be determined?
7. How should profits from fertilizers be determined? Discuss.
8. When two or more fertilizers are compared what should determine which is the most profitable? Discuss.
9. What two factors come into play in determining the profitable use of commercial fertilizers? These factors may be expressed in terms of what two economic laws?
10. State the "law of the minimum" as it is applied to fertilizers. Illustrate.
11. State the "law of diminishing returns" as it is applied to fertilizers. Illustrate.
12. Summarize the important points discussed in this chapter.

## CHAPTER XXIV

### FARMING IN REGIONS OF LIMITED RAINFALL

**Dry-Farming.**—Dry-land farming, or dry-farming, is commonly understood to mean the profitable production of crops without irrigation on lands receiving less than thirty and at least fifteen inches of rainfall annually. In reality there is no such thing as dry-farming. No crops can be produced on dry land. So-called dry-farming has for its object the reclamation of vast areas of unirrigable lands which were formerly thought to be of no agricultural value. It is a striking fact that about sixty-three per cent of the whole area of the United States receives less than thirty inches of rainfall annually. Eighteen Western states are included in this area. About twenty per cent of this area, or about 240,000,000 acres, receive less than fifteen inches. There are, therefore, more than a billion acres that may be called dry-farming lands in Western United States.

**Information Has Been Meager.**—In the past only meager and unreliable information could be secured concerning dry-land farming. Within recent years, however, experimental data have been secured which will greatly aid in solving many of the problems confronting the dry-land farmer.

It is to be understood that the climate in the dry-farming region is not uniform, but variable. One season may have almost humid, and another almost arid conditions. The distribution of the rainfall, likewise, is variable. It is not an unusual occurrence to have a single torrential downpour of rain which exceeds in the amount the normal rainfall for the month in which it occurs. At other times a monthly precipitation of 1.9 inches may come in nine light showers and prove of no practical value because all the moisture evaporates before it can penetrate the soil mulch.

**The Water Problem.**—The main problem thus far in growing crops without irrigation in regions of limited rainfall concerns the conservation of the rainfall for crop use (Chapter VIII). It has been demonstrated that by proper methods there need be no complete crop failure on suitable soils wherever the annual rainfall is

above fifteen inches. In some sections twelve inches or less of rainfall is sufficient for dry-farming. The amount of rainfall during the growing season is a better criterion of crop production than the annual rainfall.

**Soils in Dry-Farming Regions.**—Soils in dry and semi-arid climates are rich, because of the comparatively small amount of leaching during past ages. A great variety of soils exist—ranging from heavy clay and alluvial loam to fine sand and coarse gravel, and varying in depth from a few inches to many feet. A dry-farm soil should be intermediate in texture, uniform and deep, and should support a good growth of natural vegetation, preferably sagebrush.

The success of dry-farming is determined in a large measure by the deep, congenial subsoils so generally characteristic of arid and semi-arid regions. This enables the roots of crops to penetrate deeply, thus enabling them to secure deep as well as broad pasturage.

**Farming Methods.**—Many wrong ideas have prevailed concerning dry-farming methods. Recent experiments, however, seem to warrant the following statements:<sup>1</sup>

(a) No definite "system" of dry-farming has been or is likely to be established that will apply generally to all or to any considerable part of the dry-land area.

(b) No hard and fast rules can be adopted to govern the methods of tillage or of the time and depth of plowing.

(c) Deep tilling does not necessarily increase the water-holding capacity of the soil or facilitate root development.

(d) Alternate cropping and summer tillage can not be relied upon as a safe basis for a permanent agriculture or to overcome the effect of severe and long-continued droughts.

(e) The farmer can not be taught by given rules how to operate a dry-land farm.

**Crops for Dry-Farming.**—In dry-land farming the selection of proper crops and their proper seeding, care and harvesting are as important as choosing a suitable soil and preparing it properly. In general, crops cultivated in humid regions are also grown on semi-arid lands. However, varieties especially adapted to dry-farming conditions must be used. In some sections it is most important to select those crops which will make most of their

---

<sup>1</sup> United States Department of Agriculture Yearbook, 1911.

growth during the period of most rainfall, and those which will make the most efficient use of the soil moisture. Some dry-farm crops are here mentioned in the order of their importance.

*Wheat* is the leading crop—including winter and hard spring varieties.<sup>2</sup> This crop shows a closer relation between the yield and the moisture content of the soil than any other crop. In the northern portion of the dry-land area corn or other cultivated ground makes the best preparation; in the central portion, early fall plowing and cultivated ground is good; and in the southern section winter wheat seeded late on small grain stubble is most profitable. In the southern portion, land preparation for winter wheat should begin immediately after the harvest of small grains.<sup>3</sup>

*Oats* is a promising dry-land crop. Summer tillage has produced higher yields than any of the other cultural methods, but the greatest profits per acre have been realized when oats were sown on disked corn land. Where listing has been tried, it proved more profitable than fall plowing.

*Barley* grows fairly well on dry-farms, especially those varieties belonging to the beardless and hull-less types. Largest yields are produced on summer tilled land, but slightly more profits per acre have been realized when the ground is prepared with a lister instead of a plow.

*Rye* is one of the surest dry-land crops. The winter varieties are usually most satisfactory.

*Corn* is a most excellent crop to grow for fodder and to prepare the land for a crop of small grain. It has been found that no one method of seed-bed preparation seems essential to the production of this crop, especially in the Great Plains.

*Sorghums* promise to become excellent crops for dry-farming.

*Alfalfa* is a most valuable crop to grow in the valleys especially, on account of the more favorable moisture conditions. Sometimes alfalfa is planted in rows to permit of intertillage, and to lessen the draft on the moisture supply.

*Peas* have been found an excellent legume in some sections, and may be substituted for summer fallowing.

---

<sup>2</sup> The hard winter wheat, especially—Kharkow and Turkey Red of the Crimean group. The varieties of common spring wheat usually grown are the Blue Stem and Red Fife. Durum or macaroni wheat is also much grown. Department of Agriculture Bulletin 268, and Farmers' Bulletin 895.

<sup>3</sup> U. S. Farmers' Bulletin 895, 1917.

## DRY-FARMING PRACTICES

**Cultural Methods.**—On fourteen different Experiment Station farms within the Great Plains area, experiments have been conducted, some extending over eight years, in determining the comparative value of fall plowing, spring plowing, disking corn stubble, subsoiling, green manuring and summer tillage<sup>4</sup> in preparation of the soil for wheat, oats, barley, corn, milo and kafir.<sup>5</sup> Listing was also tried.<sup>6</sup>

The following general conclusions were reached: (a) When the climatic conditions are as favorable as those often experienced in all parts of the Great Plains area on all the types of soil represented, profitable crops can be produced by any one of the several different cultural methods such as are in common use; (b) when the climatic conditions are unfavorable, no profitable crop of any kind tested can be produced by any of the cultural methods under investigation.

**Plows and Depth of Plowing.**—Disk plows are commonly used. Evidence so far obtained goes to show that nothing is gained by stirring the soil to a depth greater than is done by ordinary plowing, eight inches or less in depth. Whether plowed or not, it is important to leave the ground in a condition which will retain the maximum quantity of snow during winter. Fall plowing is usually best.

**Depth, Rate and Time of Seeding.**—Depth of seeding seems to be of less importance than the proper time of seeding, which, of course, varies in different sections. Results seem to show that thin seeding is more favorable than when ordinary amounts of seed are sown per acre in humid regions, though in some sections where the rainfall is more favorable, ordinary rate of seeding is better. The grain drill is better than the broadcast sower. On the lighter soils the press-wheel drills give excellent results (p. 156).

**Moisture Conservation.**—Difference in depth of plowing seems to have no effect on moisture conservation. In some sections it has been found necessary to leave the soil uncropped but cultivated during each alternate year in order to save up enough moisture for a crop. Cultivation is an important operation in dry-

---

<sup>4</sup> Summer tillage means the tillage of an uncropped fallow field during an entire season.

<sup>5</sup> Milo and kafir are two varieties of kafir corn, one of the classes of sorghum.

<sup>6</sup> U. S. Department of Agriculture Bulletin 268.

land farming to conserve moisture. Some investigators believe that cultivation to establish and maintain a soil mulch is not so important a factor in moisture conservation as cultivation to kill weeds.

**Use of Fertilizers.**—Since the soils in dry-farming regions are generally rich, especially in the mineral elements, commercial fertilizers have not been used.

**Crop Rotation.**—In general, little has been done in determining proper rotations for dry-farming. A rotation of oats, corn and wheat has been tried with good success in some sections. For further information, see page 277.

**Stock in Dry-land Farming.**—Early dry-land farming was devoted almost exclusively to the production of crops, especially wheat. No thought was given to the maintenance of fertility. Even now little attention is being given to maintaining the productiveness of the soils. Semi-arid soils are rich in the mineral elements, but are deficient in organic matter. It seems advisable to introduce stock to utilize roughage, and especially to aid in establishing crop rotation and in maintaining fertility. Thus far dairying seems the most profitable type of stock farming.

**Good farming** is as essential to successful dry-land farming as it is elsewhere. Good farming means practicing the best methods of producing the largest crops with the greatest net profits, and leaving the soil in the best condition for the production of the crops which follow.

**Dry farming projects** may be conducted not only in regions of limited rainfall but also in regions where there is danger of summer drought. Such projects may include the growing of dry region crops, the practice of deep plowing, subsoiling, sub-surface packing, maintenance of dust mulch, use of other mulches, etc.

## QUESTIONS

1. What is meant by dry-farming? Is this kind of farming of much importance? Why?
2. Discuss the uniformity of climate and distribution of rainfall in the dry-farming regions.
3. What is the important problem in dry-land farming? What is the minimum amount of rainfall necessary?
4. Discuss the character of arid and semi-arid soils.
5. Discuss the importance of the character of the subsoil in dry-farming.
6. Have "iron-clad" farming methods been established for dry-land farming? Discuss this point.
7. Name some crops that are especially well adapted to dry-farming.

8. In general, what have been some of the results of experiments in determining the value of different cultural methods in dry-farming?
9. What is gained by deep plowing over shallow plowing?
10. Discuss the depth, rate and time of seeding in dry-farming.
11. What is the most important farm practice in moisture conservation? Why?
12. Is stock farming possible in dry-farming? Discuss its importance.
13. Is good farming essential to success in dry-land farming? What is meant by good farming, generally?
14. What dry-farming methods have you seen used, even in humid regions?



## APPENDIX

## Composition of Feeds

*Average Dry Matter, Digestible Nutrients and Fertilizing Constituents in Some Common Feeds\**

Amount in 100 Pounds

Feeds	Dry matter	Digestible Nutrients			Fertilizing Constituents		
		Crude protein	Carbohy- drates	Fat	Nitro- gen (N)	Phos- phorus (P)	Potas- sium (K)
Alfalfa hay . . . . .	91.4	10.6	39.0	0.9	2.38	0.236	1.85
Barley (grain) . . . . .	90.7	9.0	66.8	1.6	1.84	0.37	0.614
Brewers' grains (dried) . . . . .	92.5	21.5	30.5	6.1	4.24	0.431	0.075
Clover hay, alsike . . . . .	87.7	7.9	36.9	1.1	2.05	0.305	1.44
Clover hay, crimson . . . . .	89.4	9.7	36.8	1.0	2.26	0.27	1.86
Clover hay, Japan . . . . .	88.2	8.6	41.1	1.1	1.94	0.45	1.72
Clover hay, red . . . . .	87.1	7.6	39.3	1.8	2.05	0.17	1.35
Clover hay, sweet (white) . . . . .	91.4	10.9	38.2	0.7	2.32	0.29	1.05
Clover and timothy hay (mixed) . . . . .	87.8	4.0	39.7	1.1	1.38	0.2	1.58
Corn, dent . . . . .	89.5	7.5	67.8	4.6	1.62	0.3	0.332
Corn, flint . . . . .	87.8	7.7	66.1	4.6	1.66	0.296	0.324
Corn meal . . . . .	88.7	6.9	69.0	3.5	1.49	0.283	0.31
Corn silage (well matured) . . . . .	26.3	1.1	15.0	0.7	0.34	0.069	0.36
Corn stover (ears removed, very dry) . . . . .	90.6	2.2	47.8	1.0	0.94	0.196	1.07
Cottonseed meal (good) . . . . .	92.1	31.6	25.6	7.8	6.02	1.16	1.49
Cowpeas . . . . .	88.4	19.4	54.5	1.1	3.78	0.44	1.24
Cowpeas hay . . . . .	90.3	13.1	33.7	1.0	3.09	0.41	3.43
Germ oil meal (high grade) . . . . .	91.1	16.5	42.6	10.4	3.62	0.575	0.21
Gluten feed (high grade) . . . . .	91.3	21.6	51.9	3.2	4.06	0.27	0.19
Gluten meal . . . . .	90.9	30.2	43.9	4.4	5.68	0.24	0.1
Johnson grass hay . . . . .	89.9	2.9	45.0	1.0	1.06	0.183	0.94
Mangels . . . . .	9.4	0.8	6.4	0.0	0.22	0.017	0.18
Milk, cow's (whole) . . . . .	13.6	3.3	4.9	4.3	0.56	0.083	0.14
Milk, skim . . . . .	9.9	3.6	5.1	0.2	0.61	0.096	0.14
Millet hay (common) . . . . .	87.5	5.0	46.0	1.8	1.33	0.157	1.78
Mixed grasses, hay . . . . .	87.2	4.3	44.3	1.2	1.22	0.157	1.36
Oats . . . . .	90.8	9.7	52.1	3.8	1.98	0.353	0.465
Oats straw . . . . .	88.5	1.0	42.6	0.9	0.58	0.09	1.245
Oil meal (old process) . . . . .	90.9	30.2	32.6	6.7	5.42	0.742	1.054
Potatoes . . . . .	21.2	1.1	15.8	0.0	0.35	0.052	0.044
Rice meal . . . . .	90.5	7.3	48.1	10.6	1.89	..	..
Rye . . . . .	90.6	9.9	68.4	1.2	1.89	0.32	0.473
Soybeans . . . . .	90.1	30.7	22.8	14.4	5.84	0.594	2.05
Soybeans hay . . . . .	91.4	11.7	39.2	1.2	2.56	0.296	1.93
Sugar beets (roots) . . . . .	16.4	1.2	12.6	0.04	0.26	0.035	0.265
Tankage (high grade) . . . . .	92.5	56.3	..	12.7	9.7	2.14	0.72
Timothy hay . . . . .	88.4	3.0	42.8	1.2	0.99	0.135	1.13
Wheat . . . . .	89.8	9.2	67.5	1.5	1.98	0.375	0.44
Wheat bran . . . . .	89.9	12.5	41.6	3.0	2.56	1.286	1.344
Wheat middlings (shorts) . . . . .	89.6	13.3	46.3	4.3	2.77	0.92	0.98
Wheat screenings . . . . .	89.9	9.6	47.3	3.6	2.13	0.322	0.63
Whey . . . . .	7.5	1.0	4.5	0.7	0.16	0.052	0.215

For other feeds consult *Productive Feeding of Farm Animals*, Woll.

\* Compiled from *Feeds and Feeding*, Henry and Morrison, 15th Edition, 1915.

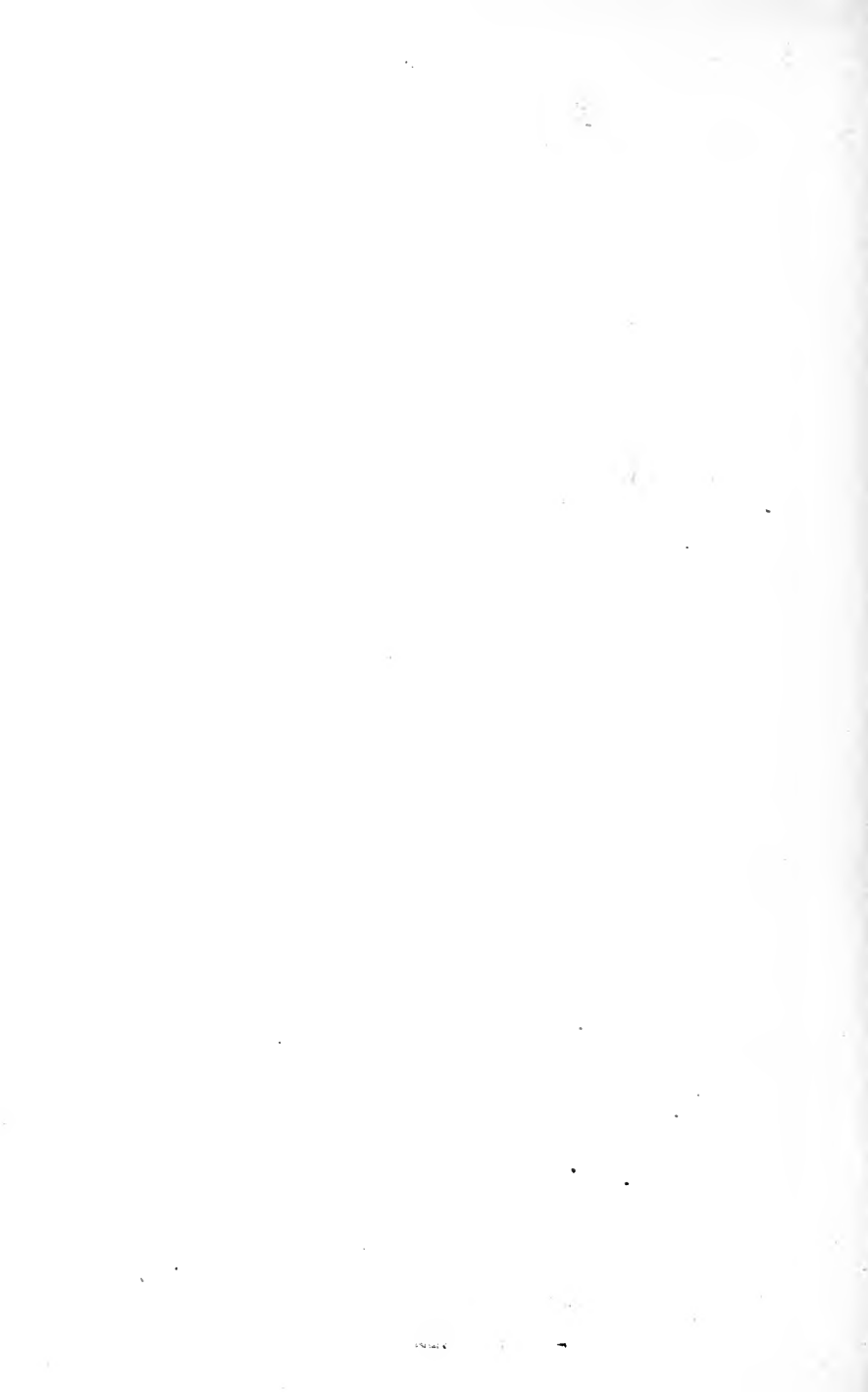

# INDEX

- Absorption of water by seeds, 49  
  favored by contact, 49  
  retarded by salts, 49
- Acid phosphate fertilizer, 197, 199  
  absorption by soil, 213  
  acid character of, 224  
  application of, 199, 299, 312, 324  
  availability of, 197  
  choice of, 201, 202  
  mixed with other materials, 211  
  on acid soil, 202  
  vs. rock phosphate, 202  
  soils, extent of, 236  
    how to tell, 233  
    lime for, 231  
    on limestone, 242, 248
- Acidity of soils. (See Soil acidity)
- Acre profits from fertilizers, 372
- Air, for soil medium, 13  
  source of carbon, 13
- Agricultural lime, defined, 229  
  comparative value of, 244  
  kinds of, 238-244  
  laboratory exercises on, 252  
  source of, 154  
  testing value of, 232, 362
- Alfalfa a heavy feeder, 65  
  amount elements removed by, 62  
  and crop rotation, 329, 339, 340  
  for sands, 316  
  good as a weed-killer, 78, 268  
  inoculation for, 230  
  lime for, 230-232  
  needs much potassium, 203  
  on acid soils, 231, 232, 249  
  rich in calcium (lime), 64  
  rich in protein, 64  
  root system of, 68  
  rotations for, 276, 277  
  when successful on acid soils, 249  
  where grown, 275
- Alkali in soil, injurious, 258  
  soil, defined, 43, 44  
    deep rooted plants for, 259  
    drainage for, 259  
    management of, 260  
  spots, 44  
    remedy in drainage, 111
- Alluvial soil, defined, 15  
  origin and value of, 17
- Alsace, potash in, 202
- Alsike clover, adaptation, 275  
  elements removed by, 62  
  response to liming, 233
- Alumina, defined, 30, 31
- Aluminum, defined, 30, 31
- Ammonia gas, defined, 174  
  in horse stable, 224
- Ammonium sulfate fertilizer, 196
- Analyzing soils, 355-368  
  for lime needs, 358  
  for nitrogen needs, 359  
  for organic matter, 359  
  for phosphorus needs, 359  
  for potassium needs, 360  
  methods of, 358
- Apatite, defined, 40
- Aphids and yields, 256, 258
- Apples, elements removed by, 69
- Arid climate, defined, 44  
  soil, characteristics of, 44, 378
- Availability of elements, defined, 54  
  affected by iron in soil, 262  
  of nitrogen fertilizers, 196  
  of phosphate fertilizers, 197  
  of potash fertilizers, 202  
  of, vs. total amount, 199, 356
- Bacteria and crop failure, 181  
  are plants, 178  
  for soil medium, 13  
  in soil, 171-2  
  legume, 172, 180  
  nitrogen-gathering, 172, 175  
  number of in manure, 216  
  soil, 13, 171  
  size of, 171
- Backfurrow, 113, 139, 148
- Barley, elements removed by, 62  
  for sands, 317  
  response to liming, 233  
  rotations for, 275, 276, 280
- Barnyard manure. (See Manure)  
  water, why colored, 224
- Basic slag fertilizer, 197, 198  
  availability of, 197  
  choice of, 202
- Basalt, defined, 39
- Beans, where grown, 281
- Bench terraces, defined, 289
- Beet, sugar, elements removed by, 62  
  root system of, 68  
  (See under Sugar beets)
- Black alkali, defined, 44
- Blank test plots, 360
- Blinding tile, defined, 119
- Blood meal fertilizer, 196, 197  
  availability of, 196  
  in relation to decay, 173
- Blue grass, elements removed by, 62  
  litmus paper, 229
- Bog cutter, 297
- "Bogus" spots in marsh soils, 302
- Bone meal, fertilizer, 197, 198  
  availability of, 197  
  choice of, 201
- Broadcast grain sower, 158
- Brome grass for sands, 317
- Buckwheat, elements removed by, 62  
  for green manuring, 66, 192, 194  
  for sands, 317  
  rotations for, 278
- Burnt lime for peat, 245  
  for soils, 243
- Business of the farmer, 37
- Cabbage, a heavy feeder, 64  
  club root of, 233, 257, 259  
  elements removed by, 62, 68, 203  
  resistance to yellows, 258, 260  
  response to liming, 233  
  root system of, 68  
  yellows and fertility, 257, 260
- Calcite, defined, 40

- Calcium, defined, 30, 31  
 amount removed by crops, 62, 63  
 amount removed by fruit, 69  
 and protein relations, 64  
 function of, in plants, 55  
 how distributed in plants, 63
- Capillary rise of water, 96  
 factors influencing, 96, 97  
 how aided, 102  
 laboratory exercises on, 105
- water, defined, 93  
 importance of, 93  
 how held by soil, 93
- Carbon, defined, 30, 32  
 dioxide, defined, 6  
 function of, in plants, 55  
 how plants secure, 35, 36  
 much used by plants, 36
- Carbonate of lime, defined, 41  
 deposit of, 239  
 for liming, 238  
 laboratory exercises on, 251  
 origin of, 41  
 test for, 238
- Carbohydrates, defined, 57  
 and potassium relations, 64  
 laboratory exercises on, 57
- Catch crops, defined, 174  
 value and uses of, 193, 272
- Chalk, natural, 243
- Chemical analysis of soils, 30, 356  
 has limitations, 355  
 uses and value of, 257, 258
- changes in soils, 6  
 composition, of animals, 36  
 plants, 36  
 soil, 29, 30
- elements, defined, 29  
 how exist in soil, 30
- formula, defined, 30  
 symbol, defined, 30  
 test for carbonates, 238  
 for soil acidity, 234
- Chloride of potash, fertilizer, 202
- Chlorophyll defined, 50
- Cherries, elements removed by, 69
- Classification of soils, 14  
 on basis of origin, 15  
 of texture, 14  
 of type, 22
- Clay, defined, 11, 12, 14  
 advantages of, 321  
 clearing, 324  
 crops to grow, 325  
 drainage in, 322  
 erosion problem in, 324  
 field studies on, 326  
 home projects on, 326  
 loam, defined, 14  
 mechanical composition of, 14, 15, 321  
 lime, use of in, 323  
 nitrogen problem in, 323  
 organic matter problem in, 323  
 particles, defined, 11, 12  
 phosphates in, 324  
 plowing in, 325  
 plowing of, 15, 142, 325  
 rotations for, 325  
 soil class, 14  
 soil management, 321, 325  
 special problems in, 321  
 sweet clover for, 323  
 tilth (good) in, 322  
 types of farming, 325  
 true, 41
- Climate, arid, defined, 44  
 effect of, on soil, 42  
 humid, defined, 42  
 relation to fertility, 80  
 semi-arid, defined, 44  
 sub-humid, defined, 42
- Clod crushers, 154, 155
- Clover, adaptation of, 275  
 elements removed by, 62  
 for green manuring, 191, 193  
 maintaining farming, 177, 191  
 marsh lands, 304  
 sand farming, 316  
 good, a weed-killer, 78, 268  
 sod better than timothy, 181  
 where grown, 275
- Club root of cabbage, 233, 258, 259
- Colluvial soil, defined, 15  
 origin and value of, 22
- Commercial fertilizers. (See Fertilizers)
- Complete fertilizers, defined, 205  
 determining equivalent of, 198, 202  
 expressing equivalent of, 205  
 use of, 205, 206
- Composition of feeds, 383  
 soil, 11, 29, 30  
 influences plant growth, 34
- Conservation of soil moisture, 100-105  
 in sand farming, 313  
 laboratory exercises on, 105, 106
- Continuous cropping defined, 264
- Coral, as agricultural lime, 243
- Corn, cultivation of, 162  
 elements removed by, 62  
 for sands, 316  
 home projects on, 169  
 on peat soils, 125, 187, 201, 204  
 production on decline, 1  
 response to fertilizers, 200, 201, 206-208  
 root development of, 53, 68  
 root-worm and fertility, 255  
 rotations for, 275-280  
 where grown, 279
- Corrugated roller, 155
- Cost of fertilizers, an expense, 372
- Cotton, elements removed by, 62  
 for sand farming, 317  
 rotations for, 279, 280  
 where grown, 279
- Cottonseed meal, fertilizer, 196, 197  
 availability of, 196  
 relation to decay, 173
- Coulters, 141
- Cover crops, 193, 272  
 for soil erosion, 288
- Cowpeas, illustrated, 191  
 elements removed by, 62  
 for green manuring, 191, 192
- Crimson clover, illustrated, 192  
 for green manuring, 191, 192  
 for sands, 316
- Crop production, and fertilizer practice, 369  
 determines fertilizer use, 369  
 relation between cost of, and  
 profits, 375  
 profitable, 369-376  
 the farmers' problem, 370  
 rotation, defined, 263  
 alfalfa in, 329, 331, 339, 340  
 application of principles, 332, 342  
 best for soil improvement, 274  
 benefits of, 264, 270  
 chart, 331  
 controls insects and diseases, 264  
 cropping problems solved by, 329

- Crop rotation, definite, defined, 263  
 in practice, 263, 275  
 economic yields resulting from, 272  
 factors determining kind of, 328  
 proper, 272  
 farm management in relation to, 327  
 fertilizers do not take place of, 271  
 fertilizing elements conserved by, 2  
 field studies on, 282, 342  
 fixed, defined, 263  
 for all farms, 341  
 for clay soils, 325  
 for cotton, 336  
 for cowpeas, 338  
 for depleted silt loams, 326  
 for dry-land farming, 277  
 for gardening, 280, 281  
 for general farming, 331, 342  
 for marsh soils, 304  
 for North Atlantic States, 277  
 for North Central States, 275  
 for Pacific States, 280  
 for sandy soils, 317  
 for South Atlantic States, 278  
 for South Central States, 279  
 for stock farming, 329  
 for truck farming, 280, 281  
 helps to maintain fertility, 268-270  
 home projects on, 282, 242  
 how to plan, 329  
   for grain farming, 330  
   for stock farming, 330  
   for truck farming, 331  
 illustrated, 332-342  
 increases organic matter, 265, 274  
 legumes in, for best results, 272  
 liming problems solved by, 276  
 not always beneficial, 271  
 on hillsides, 288  
 other points on, 339  
 practical, 328  
 problems, in illustrated, 332-342  
 remedy for diseased soil, 257  
 short better than long, 274  
 soil fertility in relation to, 263  
 soil problems solved by, 329  
 some systems of, 274  
 special, for alfalfa, 340  
 summary on practical, 341  
 systematizes farming, 328, 341  
 tith improved by, 266  
 to meet several soil problems, 338, 341  
 weeds controlled by, 268  
 wheat yields increased by, 271
- Crops, advantages in growing different, 327  
 and soil determine fertilizer needs, 208  
 as feeders, 61-63  
 because of decay, 172  
 benefited by liming, 232, 233  
 change of, not always beneficial, 271  
 demanding much potassium, 203  
 factors in growing, 75  
 failure of, and bacteria, 181  
 failure of, due to diseases, 257  
 fertility indicators, 80  
 for heavy clay soils, 325  
 for marsh lands, 305  
 for sands, 316  
 grow, in right combinations, 272  
   order, 273  
 grown, in dry-land farming, 277  
   in North Atlantic States, 277  
   in North Central States, 275  
   Crops grown in Pacific States, 280  
     in South Atlantic States, 278  
     in South Central States, 279  
   growth of, and light, 77, 78  
     and weeds, 78  
   increased by rotation, 268-271  
   injured by liming, 233  
   large, may not be most profitable, 369  
   plowing under, for green manure, 193  
   plow under or feed, 195  
   remove mineral elements, 33, 62, 63  
   secret in growing, 86, 87  
   secure elements from two sources, 172  
   tolerating soil acidity, 233  
   vary in their requirements, 64  
   yields of, affected by temperature, 51  
   in England, 2  
   in France, 2  
   in Germany, 2  
   in United States, 2  
   relatively low, 2
- Cultivation, defined, 161  
 favors nitrification, 161, 174, 357  
 level vs. hilling, 167  
 objects of, 161  
 right time for, 164  
 shallow is best, 167  
 to conserve moisture, 162
- Cultivators, 161, 166  
 Cultipacker, 155  
 Culture solution, how to make, 58  
 Cumulose soil, defined, 15  
 origin and extent of, 16  
 Cylinder fertilizer tests, 360
- Diary farms, use of manure on, 221  
 of fertilizers on, 222, 345, 353
- Deadfurrow, defined, 113
- Decay, and crops, 172  
 of rocks, 1-9  
 of soil, 9  
 organisms of, lacking, 175
- Deep tilling, 147
- Depleted soils, defined, 84  
 improvement of, 326
- Disk drills, 157  
 harrows, 151
- Disking, the seed bed, 151  
 before plowing, 153  
 for summer fallowing, 153  
 potato land for grain, 153  
 to conserve moisture, 153  
 vs. plowing, 159
- Disintegration of rocks, 1-9
- Dolomite, defined, 40
- Drag (harrow), 152
- Drainage, defined, 109  
 and percolation, 95  
 benefits of, 109-112  
 by means of pumps, 126  
 erosion prevention, 287  
 factor considered in fertility, 355  
 field studies on, 133  
 how accomplished, 112  
 in clay soil farming, 321  
 laboratory exercises on, 132, 133  
 lands needing, 112  
 of alkali soils, 131, 258  
 of marsh lands, 294  
 noted projects, 126  
 sub-surface, 113, 115, 117  
 surface, 112, 114  
 vertical, 113  
 tile, 117-126. (See under Tile drainage)  
 what determines method of, 113

- Dried blood fertilizer, 196, 197  
 Drill application of fertilizers, 201, 206-208  
 Droughty soil, 99  
 Dry-climate soil, 377  
 Dry-land farming, defined, 377  
   crops for, 277, 378  
   crop rotations for, 277, 381  
   cultural methods in, 380  
   dairying in, 381  
   extent of dry-farm lands, 377  
   farming methods in, 378  
   fertilizers for, 381  
   good farming in, 381  
   listing for, 159  
   moisture conservation in, 380  
   planting and seeding in, 380  
   plowing in, 380  
   plows for, 380  
   projects (student) in, 381  
   rainfall in, 377  
   seeding and planting in, 380  
   soils best for, 378  
   stock raising in, 381  
   water problem in, 92, 377  
   water requirement in, 91
- Dune sand, 309  
 "Dust" of the earth, 36  
 Dynamiting soils, 148
- Earth, formative period of, 5  
 Elements, defined, 29  
   amount removed by crops, 61-63  
   conserved by rotation, 267  
   contained in subsoil, 72  
   distribution of, in crops, 63  
   exchange of, in farming, 350  
   forms in which plants secure, 61  
   function of, in plants, 55  
   how exist in soil, 30  
   how plants secure, 36, 54  
   laboratory exercises on, 58  
   made available by liming, 230  
   minerals, defined, 33  
   pass through cycles, 37  
   plant-food, defined, 54  
   removed by fruit, 69  
   required by plants, 35  
   source of, for plants, 35  
   supply of, in soil, 33  
   why some soils are deficient in, 40  
   (See under Plant-food elements)
- Erosion. (See Soil erosion)  
 Experiment Station fertilizer tests, 362  
 Experimental fertilizer plots, 360-368  
 Exportation on decline, 1
- Fall plowing, 144  
   retarded nitrification, 357
- Farm crops consumed in U. S., 1  
 Farm management, 327  
   and crop rotations, 327-338  
   crop rotation chart aids in, 331  
   drainage relations, 112  
   soil problems common in, 327  
   successful, 327  
   systematized by rotation, 328, 341
- Farmer's business, 37  
 Farmers conduct fertilizer tests, 362  
 Farm soil examination, 368  
   survey, 368
- Farming, account with plant-food elements  
   in, 347-353  
   clay lands, 325  
   for profit, 369-376  
   grain, and soil depletion, 344
- Farming, grain, revised, 344  
   and stock, combined, 347  
   vs. stock, 343, 346  
   in irrigated sections, 131  
   in regions of little rainfall, 377  
   in relation to soil fertility, 343  
   marsh lands, 293-307  
   N and P balance in, 347-353  
   sandy soils, 309-319  
     types of, 318  
   stock, and fertility, 345  
     is popular, 345  
     vs. grain, 343, 346  
   systems of, 343  
   trials in Illinois, 347  
   in Ohio, 345, 346
- Feeding of crops, 61, 63  
   power of plants, 66  
   stock, elements lost in, 350, 351
- Feeds, fertilizing constituents in, 383  
   nutrient composition of, 383
- Feldspar, defined, 40  
 Fertile soil, defined, 75  
   factors determining, 75
- Fertility. (See Soil fertility)  
 Fertilization, defined, 190  
   and liming, 231  
   by alluvial deposits, 18
- Fertilizer, attachments, 212  
   cost of, an expense, 372  
   practice and profits, 369  
     law of diminishing returns in, 374  
     of the minimum in, 373  
   tests, 67, 204, 223, 360-368  
     how experiment stations conduct, 363  
     how farmers can conduct, 362  
     in general, 360-373  
     on marsh soils, 200, 201, 204, 298, 300, 303  
     points to observe, 366  
     value of untreated plot, 370
- Fertilizers, 196-213  
   absorption of, by soil, 213  
   amount to apply, 211, 299, 312-313, 324  
   broadcast vs. hill application, 213  
   chemical analysis to tell need of, 355  
   classes of, 196  
   commercial, defined, 196  
   computing profits from, 372  
   cost of, 207  
   determined by soil and crop, 208  
   determining profits from, 371  
   diagnosing soils for need of, 355  
   drill and hill application of, 211-213  
   economic laws in relation to, 373  
   effect of lime on, 230  
   efficiency of, increased by green manure, 209  
     liming, 230, 231  
     moisture in soil, 205  
     organic matter, 173  
   fertility and fertilizer relations, 206  
   for marsh soils, 297-300  
   for peat soils, 297, 303  
   for sands, 311-313  
   green manuring helps, 209  
   high grade vs. low grade, 210  
   hill and drill application of, 211-213  
   home mixing of, 210  
     projects on, 225, 376  
   how elements in, expressed, 196  
     to apply, 211-313  
     to determine need of, 355-368  
   indirect, 196

- Fertilizers, in general, 205  
 in maintaining fertility, 206  
 laboratory exercises on, 223, 224  
 lasting effects of, 213  
 low grade vs. high, 210  
 most profitable, 371  
 need of, determined by chemical analysis of soil, 355-358  
 examining soil conditions, 355, 356  
 fertilizer tests in field, 67, 364-368  
 pot tests, 204, 298, 360  
 soil and crop needs, 204, 208  
 pot tests for, 204, 298, 360  
 how to make, 223  
 profits determine use of, 207, 369  
 from, how to compute, 372  
 rules for use of, 210  
 soil and crop determine need of, 208  
 testing in the field, 360-368  
 importance of, 67, 68  
 in pots, 204, 298, 360  
 how to do, 223  
 not fully reliable, 204, 360  
 units, defined, 207  
 use of, determined by profits, 207, 369  
 by economic laws, 373  
 valueless without decay, 173  
 when fail, 205  
 most profitable, 371, 375
- Fertilizing elements, defined, 33  
 account with, in farming, 347-353  
 balance sheet of, for a grain rotation, 348  
 on dairy farms, 348, 353  
 conserved by crop rotation, 267  
 exchange of, in farming, 350-353  
 gained from purchased feeds, 350-352  
 in feeds, 383  
 loss and gain of, in farming, 349, 350  
 lost by soil erosion, 283  
 in feeding transaction, 349, 350  
 regained in manure, 350
- Field tests, 67, 188, 189, 200, 201, 204, 206-208, 303, 360
- Fine sandy loam, defined, 14
- Fire-fanging of manure, 218
- Flax, elements removed by, 62  
 crop rotation for, 276
- Floating bogs, 16
- Flooding (irrigation), 129
- Food manufactured in plants, 37, 50  
 production per acre, 343  
 as grain vs. as meat, 343
- Frost, effect of, on rocks, 6  
 on marsh lands, 302-303
- Fruit, elements removed by, 69
- Fruition period, 56
- Furrow irrigation, 130
- Garden crops and liming, 233
- Gases as weathering agents, 6
- Germination (period), 47  
 contact with soil, a factor, 49  
 critical, 47  
 fertilizers affecting, 49  
 laboratory exercises on, 56  
 moisture in relation to, 49  
 requirements and conditions for, 48  
 salts in relation to, 49  
 temperature in relation to, 49  
 water in relation to, 49
- Glacial soil, defined, 15  
 origin of, 18  
 quality of, 21
- Glaciers, effects of, 19-21  
 story of the, 18
- Good farming, 381
- Grade lath, use of, 118  
 line, illustrated, 119
- Gradient, defined, 117
- Grain drills, 156-158  
 for sand farming, 315  
 farming, defined, 343  
 for densely populated countries, 343  
 has led to soil depletion, 344  
 importance of, 343  
 maintaining fertility in, 347  
 revised, 344  
 stock and, compared, 346  
 on potato land, 153
- Grains, lodging of, 64
- Granite, defined, 39  
 soil from, 42
- Grass on clay soils, 325  
 on sands, 316
- Green manuring, defined, 190  
 an old practice, 191  
 benefits of, 190, 191, 194  
 best time for, 193  
 crops for, 192  
 cover crops for, 190  
 cultivation important in, 194  
 feeding the crop vs., 195  
 fertilizer relations, 209  
 for clay soils, 324  
 for cultivated crops, 194  
 for depleted silt loams, 326  
 for sands, 310  
 for soil improvement, 194  
 hints on, 195  
 in relation to liming, 231  
 importance of, in South, 193  
 legumes best for, 190  
 plowing under the crop, 193  
 precautions in, 193  
 to maintain organic matter, 191  
 Varro on, 191, 192  
 vs. fertilizers, 191  
 weeds for, 194
- Greensand, 243
- Gridiron system of tiling, 122
- Ground bone fertilizer, 197, 198  
 water table, defined, 113
- Growing period of plants, 49  
 activities in, 50  
 conditions and requirements in, 50, 51
- Gully erosion, defined, 286
- Gypsum, defined, 40  
 for alkali soils, 259  
 for conserving manure, 218  
 for liming, 244
- Hardpan, defined, 124
- Harmful agents in soil, 255-262, 356
- Harrow, 151-154
- Harrowing, 151
- Heat and cold, effects of, 6
- Heavy soil, defined, 14
- Hematite, defined, 40
- Hemp, elements removed by, 62  
 response to liming, 233  
 soil for, 68
- Herringbone system of tiling, 122
- Hoe drill, 158

- Home mixing of fertilizer, 210  
     materials not to mix, 211  
     mixing rules, 210
- Hornblende, defined, 40
- Humid climate, defined, 4
- Humus, defined, 12
- Hydrated lime, 238, 244
- Hydrogen, defined, 30, 33
- Ice, a weathering agent, 6  
     the Ice Age, 18
- Igneous rocks, defined, 39
- Illinois grain vs. stock farming test, 346, 347
- Infertility, defined, 80  
     causes of, 85  
     diagnosing, 86  
     toxin theory of, 261
- Inoculation, defined, 182  
     a fertility factor, 182, 356  
     fails on acid soil, 232  
     field studies on, 185  
     for better crops, 182  
     home projects on, 185  
     how often, 184  
     laboratory exercises on, 185  
     methods of, 182  
     when succeeds on acid soil, 184, 232
- Intertillage, 135, 161, 163
- Iron, defined, 30, 31  
     function of, in plants, 56  
     rust, defined, 30, 31
- Irrigation, affected by soil erosion, 284  
     an art of antiquity, 132  
     defined, 126  
     farming under, 131  
     how water is applied, 128  
         secured, 128  
     methods of, 129, 130  
     much land needs, 131  
     objects of, 127  
     profits in irrigation farming, 131
- Jointers, 141  
     adjustments of, 141
- Kafir corn, rotation for, 277, 280  
     where grown, 277
- Kainit, fertilizer, 202, 203
- Labor income, defined, 370
- Laboratory instructions, 4
- Lacustrine soil, defined, 15  
     origin and value of, 21
- Land clearing, on marsh, 295  
     on steep slopes, 285  
     drainage. (See Drainage)
- rental, defined, 370
- Land-plaster. (See Gypsum)
- Landslides, defined, 286
- Lateral (tile), defined, 121
- Law of diminishing returns, 374  
     the minimum, 373
- Leaching of manure, 350  
     of nitrogen from soil, 349
- Legumes, compared with non-legumes, 178  
     for dry-land farming, 277  
     for green manuring, 191-193  
     for North Atlantic States, 278  
     for North Central States, 275  
     for Pacific States, 280  
     for South Atlantic States, 278  
     for South Central States, 279  
     how they improve soils, 180  
     nitrogen gathered by, 178, 180  
     nodules on, 176-183  
     to solve nitrogen problem, 197
- Light and crop growth, 77, 78  
     "Light" soil, defined, 15
- Limite, defined, 244
- Lime, agricultural, defined, 229  
     amount to apply, 245  
     as toxin destroyer, 261  
     carbonate of, defined, 41  
     carbonates, forms of, 238  
     comparative value of, 244  
     conserved by cropping, 247  
     defined, 30, 34  
     for clay soils, 243, 245, 323  
     for improving tilth, 323  
     for marsh soils, 245, 291  
     for pastures, 247  
     for quick results, 245  
     for root zone, 248  
     for sandy soils, 245, 312  
     from beet sugar factories, 243, 250  
     how it acts in soil, 229  
         to apply, 245  
         often to apply, 247  
         to determine good, 245  
     hydrated lime, 238, 244  
     kinds of agricultural, 238  
     laboratory exercises on, 252  
     lump or burnt, 243  
     misuse of, 249  
     mixing with manure, 219  
         fertilizers, 211  
     soil toxins relations, 262  
     spreader, 246  
     testing soil for need of, 232, 358, 362, 364  
     too much may prove harmful, 262  
     use and misuse of, 249  
     waste, 243
- Liming, alfalfa response to, 232, 233  
     beneficial in green manuring, 231  
     benefits of, 229  
     best material for, 244  
     better than manure, 231  
     clay soils, 243, 245, 323  
     club root in relation to, 233  
     crops benefited by, 232, 233  
         injured by, 233  
     deep plowing no substitute for, 248  
     defined, 229  
     fertility regulated by, 250  
     for all crops 233  
     for quick results, 245  
     for tilth improvement, 323  
     frequency of, 247  
     home projects on, 253  
     improves acid soils, 229  
     labor saved through, 231  
     land-plaster for, 244  
     marsh soils, 245, 301  
     only one of fertility factors, 250  
     pastures, 247  
     peas respond to, 233  
     peat soils, 245, 301  
     poor soils, 245  
     potato scab in relation to, 233  
     problems solved by rotation, 267  
     relation to soil toxins, 262  
     remedy for club root, 233  
     restoring worn-out soils, 250  
     sandy soils, 245, 312  
     to reduce total acidity, 249  
     when most profitable, 231
- Limestone, acid soil possible on, 242  
     coarse, is slow acting, 240  
     defined, 39  
     dolomitic, 238



- Limestone**, formation of, 43  
   home grinding of, 240, 241  
   how soils form from 42, 43  
   laboratory exercises on, 251  
   pulverized, 238  
   pulverizers, 240, 241  
   quarry, 239  
**Limoid**, meaning of, 244  
**Line of tile** defined, 117  
**Liquid manure**, 215  
**Lister**, 159  
   cultivator, 164  
**Listing**, defined, 159, 160  
**Litmus paper**, defined, 229  
   laboratory exercises on, 251, 252  
   test for acidity, 234  
**Loam**, defined, 14  
   rotations for, 276  
**Loess soil**, defined, 15  
   origin and value of, 32  
**Lodging of grain**, 64  
**Lump lime**, defined, 243  
  
**Magnesia**, defined, 30, 31  
**Magnesium**, function of, in plants 56  
   defined, 30, 31  
**Main (tile)**, defined, 121  
**Maintaining fertility**, 206, 271  
**Mammoth clover** for sands, 316  
**Managerial income**, defined, 370  
**Manure (barnyard)**, a quick fertilizer, 216  
   affected by age of animal, 215  
   by bedding, 215  
   by feeding, 214  
   amount produced by stock, 215  
   application to clover fields, 220  
   as a fertilizer, 213  
   availability of, 216  
   bacteria in, 216  
   "burning" of, 218  
   care of, 216-218  
   compost heap, 218  
   cow, 214  
   defined, 213  
   demonstrations on, 223, 224  
   differ in fertilizing value, 214  
   facts about, 213  
   fire-fanging of, 218  
   for gardening, 218  
   for marsh soils, 200, 300  
   for maintaining fertility, 222  
   for sands, 310  
   for soil improvement, 216, 250  
   gypsum for conserving, 218  
   hen, 214, 218  
   hog, 214  
   horse, 214  
   land-plaster for conserving, 218  
   lasting effects of, 221  
   leaching of, 216, 222, 350  
   light vs. heavy applications, 219  
   lime in manure heaps, 219  
   liquid, valuable, 215  
   loss of ammonia from, 223  
   mixing horse and cow, 219  
   phosphate with, 220, 221  
   not a perfect fertilizer, 221  
   open yard vs. stall, 216, 222  
   pig, 214  
   pits for, 217  
   plowing under vs. disking in, 219  
   poultry, 214, 218  
   production of, by stock, 215  
   reinforcing, 220-222  
   residual effects of, 221  
  
**Manure (barnyard)**, rock phosphate for, 220-222  
   sheds for, 217  
   sheep, 214  
   solubility of elements in, 216  
   stall vs. open yard, 216, 222  
   storing, 217  
   three-fold value of, 216  
   top-dressing with, 220  
   value of, 213, 214  
   vs. mineral fertilizers on marsh, 220, 300  
   winter applications of, 221  
   yard vs. stall, 216, 222  
**Mapping of soils**, 22  
**Marble**, defined, 39  
   dust for liming, 243  
**Marine soils**, defined, 15  
   origin and value of, 21  
**Marl**, defined, 243  
   for liming, 243  
   origin of, 17, 243  
**Marsh**, defined, 14  
   soils, 16, 293  
   advantages in farming, 293  
   "bogus" spots in, 302  
   clearing and breaking, 295  
   clover for, 304  
   crop for, 302, 305  
   crop rotation, 304  
   drainage of, 117, 294  
   extensive farming on, 306, 307  
   fertilizer tests on, 200, 201, 204, 298, 300, 303  
   fertilizers for, 199, 203, 297-300  
   field studies on, 307  
   frost on, 302, 303  
   home projects on, 307  
   kinds of, 293  
   management of, 293  
   manure for, 300  
   most desirable, 294  
   types of, 293  
     of farming on, 306  
**Marsh-border soils**, 293  
   drainage of, 294  
**Maximum production**, 83  
**Meadow**, defined, 25  
**Mechanical composition of soil**, 14, 15  
**Medium red clover**, elements removed by, 62  
   for sands, 316  
**Metamorphic rocks**, defined, 39  
**Mica**, defined, 40  
**Micro-organisms**, 171  
**Middle-breaker**, 160  
**Mineral elements**, defined, 30, 33  
   removed by crops, 33  
   fertilizers on marsh, 200  
   matter, defined, 5  
   rock-forming, 40  
   laboratory exercises on, 45  
   soils, defined, 41  
**Mixed fertilizers**, defined, 205  
   advantages in using, 209  
   application of, 209  
   determining equivalents, 198, 202  
   expressing equivalents, 198, 202, 205  
   for sands, 313  
   home mixing of, 210, 211  
   use of, 205-208  
   vs. single, 209  
**Moisture**, and germination, 49  
   conservation and control, 100  
   laboratory exercises on, 105  
   supply on sands, 313  
**Molds**, soil organisms, 171

- Muck soil, as soil type, 25  
 advantages in farming, 293  
 characteristics of, 293  
 defined, 16, 25  
 fertilizers for, 199, 203, 297-300  
 least desirable, 294  
 most desirable, 294  
 origin of, 16, 17  
 problems in cropping, 294  
 value of, 16  
 why better than peat, 41
- Mulches, 104. (See Soil mulch)
- Muriate of potash, fertilizer, 202
- Natural systems of tiling, 120, 121
- Nitrate fertilizers. (See Nitrogen fertilizers)  
 of soda, 197
- Nitrates, defined, 174, 175
- Nitrification, explained, 173, 175  
 destroys organic matter, 175  
 favored by cultivation, 357  
 laboratory exercises on, 185  
 retarded by fall plowing, 357
- Nitrifying bacteria, 174, 175  
 lacking in some soils, 175
- Nitrogen, defined, 30, 31  
 amount removed by crops, 62, 63  
 by fruit, 69  
 an account with, in farming, 347  
 analyzing soils for, 359  
 balance sheet in farming, 347-353  
 contained in feeds, 383  
 fertilizers, 196  
 function of, in plants, 55  
 gain in farming, 351-353  
 how held in soils, 33  
 much fixed by bacteria, 178  
 plants secure, 35, 36  
 in relation to fertility, 187  
 losses by soil leaching, 351  
 from manure, 216, 350  
 problem in sand farming, 310  
 solved by legumes, 197  
 supply of, in soils, 70, 71
- Nitrogen fertilizers, 196  
 availability of, 196  
 for sands, 310  
 leached from soil, 196, 213  
 needs increased, 209
- fixation, defined, 178  
 amount of nitrogen fixed, 178, 180  
 by molds, 178  
 by soil bacteria, 175-180  
 by use of electricity, 178  
 how accomplished, 179
- Nitrogen-phosphorus balance sheet, 347-353  
 illustrated, 352-353  
 in grain farming, 348  
 on a dairy farm, 348
- Nodule bacteria, 172, 175, 180  
 are plants, 178  
 conditions favoring, 184  
 different kinds of, 182  
 discovery of, 176  
 how they work, 179  
 in relation to crop failure, 181  
 same for different legumes, 182
- Nodules, defined, 179  
 alfalfa, 178  
 crimson clover, 177  
 garden pea, 183  
 inside of lupine, 179  
 medium red clover, 177  
 soybean, 176
- Nutrient solution for plants, 58
- Oats, elements removed by, 62  
 for green manure, 192  
 for sand farming, 317  
 response to phosphates, 189  
 rotations for, 275, 276  
 vs. barley to grow, 66  
 where grown, 276
- Ohio grain-farming trial, 345  
 grain vs. stock farming, 346  
 test plots in field, 361-363
- One-crop system, defined, 264  
 danger in, 264
- Onions, elements removed by, 62  
 root system of, 68
- Organic matter, defined, 6  
 aids decay of soil, 173  
 chemical composition of, 30, 175  
 decomposition of, 175  
 destroyed by nitrification, 175  
 fertility relations, 356  
 improves tilth, 266, 323  
 increases water-holding capacity,  
 98, 102  
 increased by rotation, 265  
 by fertilization, 266  
 in sand farming, 310  
 laboratory exercises on, 223  
 lessens soil erosion, 287  
 maintained by green manures, 191  
 maintains farming system, 191  
 makes fertilizers more effective, 173  
 rapid reduction of, 266  
 rotations to increase, 274
- Organisms in soil, 13, 171  
 causing decay, 171, 172  
 in relation to fertility, 171
- Osmosis, defined, 54
- Outlet ditch, defined, 115  
 of tile drains, 122, 123
- Oxygen, defined, 6, 30  
 and germination, 48  
 laboratory exercises on, 58
- Parallel system in tiling, 122
- Pasture on sands, 317
- Pasturing and soil erosion, 286  
 loss of elements in, 351
- Peaches, elements removed by, 69
- Peanuts, response to liming, 233  
 rotations for, 279
- Pears, elements removed by, 69
- Peas, elements removed by, 62, 63  
 injury from blight, 257  
 response to liming, 233  
 rotations for, 276, 278, 280
- Peat soil, advantages in cropping, 293  
 as soil type, 25  
 bogs on, 297  
 burning of, 295  
 characteristics of, 293  
 cabbage on, 204, 305  
 clover for, 304  
 corn on, 187, 201, 236, 296, 298,  
 303, 305  
 crop rotation on, 304  
 crops for, 303, 305  
 deficient in mineral elements, 72  
 defined, 16, 25  
 drainage for, 294  
 extensive farming on, 306, 307  
 fertilizers for, 187, 201, 297-300, 303  
 firm seed bed important, 302  
 for blueberries, 234  
 for cranberries, 234  
 for sand improvement, 315

- Peat soil, grain on peat, 300, 305  
 home projects on, 308  
 how wrongly advertised, 72  
 least desirable, 294  
 lime for, 245, 301  
 manure for, 300  
 mild alkali on, 236  
 most desirable, 294  
 nitrogen fertilizer for, 299  
 problem on, 301  
 origin of, 16, 17  
 phosphates for, 299, 300  
 plowing, 295, 256  
 potash fertilizer for, 204, 299  
 problems in farming, 294  
 rape for, 306  
 rock phosphate on, 200, 201, 299, 300  
 roller for, 155, 302  
 seed-bed preparation, 297, 302  
 types of farming on, 306, 307  
 value of, 16, 294, 307  
 when acid, 236  
 non-acid, 236  
 why deficient in K and P, 40  
 wood ashes for, 301
- Percolation, defined, 94  
 aided by roots and worms, 95  
 importance of, 95
- Phosphate fertilizers, 197  
 acid vs. rock, 202  
 availability of, 197  
 choice of, 201  
 cost of, 207  
 determining equivalents, 198  
 expressing equivalents, 198  
 fertility relations, 222  
 for acid soils, 202  
 for clay soils, 324'  
 for marsh soils, 201, 299  
 for reinforcing manure, 221, 222  
 for sandy soils, 312  
 for soil improvement, 326  
 home projects on, 253  
 results from, 188, 189, 199-201  
 rock vs. acid phosphate, 202  
 soils needing, 199  
 testing value of, 189, 364, 365  
 rock. (See Rock phosphate)
- "Phosphoric acid," defined, 30, 34
- Phosphorus, defined, 30, 32  
 amount removed by crops, 62, 63  
 by fruit, 69  
 analysis, value of, 359  
 available rather than total, 199  
 contained in feeds, 383  
 distribution of, in plants, 63  
 fertility relations, 85, 187  
 function of, in plants, 55  
 lost in growing tobacco, 267  
 purchased in feeds, 199  
 supply of, in soils, 70, 72
- Phosphorus-nitrogen balance sheet, 347  
 illustrated, 352, 353  
 in grain farming, 348  
 on a dairy farm, 348
- Planker, 154
- Plant, a factory, 50  
 growth of, affected by soil, 34, 51  
 by temperature, 51  
 in nutrient solutions, 58  
 laboratory exercises on, 59  
 relation to soil and air, 34, 36  
 to animals, 36
- Plants, conditions for growth of, 47
- Plants, feeding power of, 66  
 great work of, 37  
 growth of in darkness, 52  
 subjects for study, 67
- Plant-food elements, defined, 54  
 account with in farming, 347-353  
 amount regained in manure, 350  
 available vs. total, 356  
 crops feed on, 61  
 exchange of, in farming, 350-353  
 gain and loss of, in farming, 349  
 gain of, how determined, 351-353  
 gained from purchased feeds, 350-352  
 in soils, 71  
 in subsoils, 72  
 laboratory exercises on, 58  
 loss and gain of, illustrated, 349, 350  
 losses of, how determined, 351-353  
 lost by pasturing, 351  
 by soil erosion, 283  
 leaching, 349  
 in feeding transaction, 349, 350  
 materials supplying, 190  
 total vs. available amount, 356
- Planting and seeding, 156
- Plow, 138-150  
 best time to, 144  
 disk, 142  
 equipment for the, 138  
 gang, 149, 150  
 general purpose, 141  
 hillside, 147  
 its work, 138-140  
 left-hand, 148  
 parts of a, 140  
 prairie breaker, 144  
 right-hand, 148  
 sod, 141  
 stubble, 141  
 subsoil, 145  
 walking, 140, 141
- Plowing, 138-150  
 chain for turning weeds, 194  
 clay soils, 325  
 fall, 144, 146  
 hillside, 147, 149  
 moderately deep best, 146  
 no substitute for liming, 248  
 retarded nitrification, 357  
 sands, 315  
 sod, 140, 143  
 spring, 146  
 stubble land, 138  
 tractor, 149, 150  
 vs. disking, 159  
 when green manuring, 193  
 with subsoil plow, 145
- Plow sole, defined, 147
- Pot tests for soil needs, 204, 223, 298, 360  
 not fully reliable, 204, 360
- Potash, defined, 30, 34  
 true meaning of, 34
- Potash fertilizers, 202  
 absorbed by soils, 213  
 availability of, 202  
 cost of, 207  
 determining equivalents, 202  
 expressing equivalents, 202  
 for clay soils, 324  
 for marsh lands, 203, 204, 297  
 for peat soils, 203, 208, 297  
 for sands, 312, 313  
 soils needing, 360  
 sources of, 202

- Potash fertilizers, uses of, 203, 204  
 Potassium, amount removed by crops, 62,  
   63, 69  
   carbohydrate relations, 64  
   chloride, fertilizer, 202  
   defined, 30, 32  
   distribution of, in plants, 63  
   fertility relations, 187, 360  
   fertilizers. (See Potash)  
   function of, in plants, 55  
   in feeds, 383  
   protein relations, 64  
   sulfate, 202  
   supply in soils, 70, 71  
     in subsoils, 72
- Potato, cultivation for, 168  
 elements removed by, 63  
 for clay soils, 325  
 for marsh lands, 305  
 for sandy soils, 316  
 high yield of, 82, 87  
 response to fertilizers, 188  
 rotations for, 276  
 scab, disease, 265  
   lime and, 233  
   rotation a remedy, 265
- Press drills, 156, 314  
 Profitable crop production, 369-375  
   acre profits, 371  
   fertilizer, determining, 371  
   liming, 231, 232
- Profits and fertilizers, 207  
 basis on which to compute, 372  
 determining from fertilizers, 371  
 per acre, 371  
 relation of, to cost of production, 375
- Protein and nitrogen in crops, 63  
 Pulverized limestone, 238  
 Pulverizers, 152-155  
 Pyrite, defined, 40 /
- Quartz, defined, 40  
 Quartzite, defined, 39  
 Quicklime for liming, 243
- Rainfall, at right time, 91  
 amount evaporated, 91  
   lost, 100  
   used by crops, 100  
   map of the United States, 101
- Rape for green manure, 192  
 Raspberries, elements removed by, 69
- Residual soil, defined, 15  
 origin and extent, 16
- Rice, rotation for, 280  
 Rich soil, defined, 66  
 Ridge terraces, defined, 288, 289  
 River bottom erosion, 287
- Rocks, affecting soils, 39  
 classes of, 39  
 defined, 40  
 field studies on, 46  
 laboratory exercises on, 46
- Rock phosphate, fertilizer, 197, 198  
 availability of, 197  
 choice of, 201, 202  
 deposits of, 198  
 for black, prairie soils, 201, 202  
 for clay soils, 324  
 for depleted silt loams, 326  
 for marsh soils, 200, 300  
 for reinforcing manure, 220, 222  
 for sands, 313  
 how to use, 198  
 in relation to decay, 173
- Rock phosphate, results with manure, 220,  
 222  
   vs. acid phosphate, 202  
   weathering, defined, 6-9  
   products of, 41
- Rock-forming minerals, 40  
 laboratory exercises on, 45
- Roller and tilth, 54, 154-156  
 for marsh soils, 302  
 for sandy soils, 313
- Rollers, 154, 155
- Roosevelt Dam, 129
- Root, growth and drainage, 110  
 hairs, 68, 69  
 of corn plant, 53  
 maggots, 256  
 systems of plants, 68
- Root-knot, 257
- Rotation. (See Crop rotation)  
 chart, 331
- Rothamsted Experiment Station, 374
- Rowen, defined, 195
- Rye, elements removed by, 63  
 for green manure, 192  
 for marsh soils, 305  
 for sands, 316  
 rotations for, 276
- Salt of the sea, 43
- Salts, and germination, 49  
 in soil medium, 13  
 products of nitrification, 175  
   of rock weathering, 41
- Sand grains, defined, 12  
 soil, defined, 14
- Sands, advantages in cropping, 309  
 blowing of, 314  
 crop rotations for, 317  
 crops for, 315  
 dune, 309  
 fertilizers for, 310-313  
 field studies on, 320  
 grain drills for, 315  
 green manuring for, 194, 310  
 home projects on, 320  
 improvement of, 311  
 kinds of, 14, 309  
 lime for, 240, 245, 312  
 liming, 312  
 management of, 309-320  
 manure for, 310  
 mixed fertilizers for, 313  
 moisture supply in, 313  
 nitrogen fertilizer for, 311  
 organic matter important in, 310  
 pasture on, 317  
 peat for improving, 315  
 phosphates for, 312  
 plowing, 315  
 potash for, 312  
 problems in cropping, 310  
 rock phosphate for, 313  
 rotation improves, 266  
 rotations for, 276  
 seed-bed preparation, 313  
 soybeans for, 312, 316  
 stock farming on, 329  
 subsoiling, 313  
 sugar beets for, 317  
 tiling, 120  
 types of soils, 309  
   of farming on, 318  
 vegetation indicates value of, 309  
 velvet bean for, 310  
 water-holding power of, 98, 313

- Sands, weight of, 15, 71**  
**Sandstone, defined, 39**  
   soil derived from, 42  
**Sandy loam, defined, 14**  
   rotation for, 276  
**Sandy soils, defined, 14**  
   kinds of, 309  
   (See under Sands)  
**Schist, defined, 39**  
**Sedentary soils, 15**  
**Sedimentary rocks, 39**  
**Sediments, amount in streams, 17**  
   carried into Gulf of Mexico, 18  
   soils from, 17  
   source of, 17  
**Seed bed, 48, 49, 135, 156**  
   good, defined, 54  
   favors planting, 156  
   for peat soils, 302  
   for sandy soils, 313  
   preparation of, 48, 138  
**Seeders, 157, 158**  
**Seeding and planting, 156**  
**Seeds, absorption by, 49**  
   contact with soil, 49, 156  
   fate of, when planted, 47  
   laboratory exercises on, 47  
   relation to seed bed, 51, 156  
   what constitutes good, 76, 77  
**Seepage, defined, 95**  
**Semi-arid climate, 49**  
   soils, 378  
**Shale, defined, 39**  
   formation of, 43  
   soil derived from, 42  
**Shavings for bedding, 351**  
**Sheet erosion, defined, 286**  
**Shells, for liming, 243**  
   form limestone, 43  
   origin of, 43  
**Shoe drills, 158**  
**Silica, defined, 30, 31**  
**Silicon, defined 31**  
**Silt, defined, 12**  
   loam, defined, 146  
**Skinner system of irrigation, 130**  
**Slate, defined, 39**  
   soil derived from, 42  
**Smoothing harrow, 152**  
**Sod plowing, 140, 142, 143**  
**Sod plows, 141, 144**  
**Sodium, defined, 30, 32**  
   nitrate fertilizer, 196  
**Soil, defined, 5**  
   acidity, defined, 45, 229  
     alfalfa and clover indicating, 234  
     blueberries indicate, 234  
     cause of, 237  
     chemical tests for, 234  
     cranberry indicating, 234  
     crops injured by, 233  
     crops tolerating, 233  
     demonstrations on, 251  
     fertility relations, 229  
     field studies on, 253  
     gypsum for, 244  
     harmful effects of, 229  
     horsetail rush indicates, 236  
     how determined, 233  
     laboratory exercises on, 253  
     land-plaster for, 244  
     lime to correct, 229  
     litmus paper test for, 234  
     lowers fertility, 229  
     low wet lands indicating, 236  
     Soil, mild alkali indicating, 236  
       mineral acids cause of, 239  
       nature of, 238  
       not harmful to roots, 248  
       not necessary to correct all, 249  
       organic acids cause of, 237  
       plants indicating, 234  
       prevalence of, 237  
       roots not injured by, 248  
       sheep sorrel indicating, 235, 236  
       Truog test for, 234  
       unfavorable to bacteria, 230  
       weeds indicating, 235  
   a complex medium, 12  
   alluvial, defined, 15, 17  
   a reservoir, 98  
   bacteria, 171.  
     (See Soil bacteria)  
     affected by liming, 230  
     conditions favoring, 184  
     nodule bacteria, 180  
     non-symbiotic, 178  
     number in soils, 171  
     symbiotic 178  
   barley, 66  
   carried away, 9  
   chemical analysis of, 355, 356  
     collecting for, 358  
     for lime needs, 358  
     for nitrogen, 359  
     for organic matter, 359  
     for phosphorus, 359  
     for potassium, 360  
     how made, 358  
     uses of, 358  
   composition of, 29  
     affecting plant growth, 34  
   classes of, 14  
   classification, 14  
     on basis of origin, 15  
     on texture, 14  
     on type, 22-24  
     laboratory exercises, 26, 27  
   colluvial-soil, 15, 22  
   components of, 11  
   common meaning of, 11  
   cumulose, defined, 15, 16  
   depletion, defined, 84, 85  
     indicated by nitrogen analyses, 359  
     phosphorus analyses, 85, 250  
   in grain farming, 344  
   in stock farming, 345  
   descriptions of, 22  
   erosion, 17, 95, 283  
     a serious problem, 283  
     causes of, 285  
     causing loss of elements, 283, 350, 351  
     effect of, on irrigation, 284  
       on water power, 284  
     field studies on, 292  
     grazing in relation to, 286  
     injures crop production, 285  
     injuries resulting from, 283, 284  
     interferes with navigation, 284  
     in the United States, 17, 18, 283  
     kinds of, 286  
     on steep slopes, 285  
     pasturing in relation to, 286  
     prevention of, 287  
     problem in clay management, 324  
     soil organic matter relations, 287  
     projects on, 292  
   exhaustion. (See Soil depletion)  
   factor in plant growth, 47

- Soil fertility, defined, 79  
 affected by harmful agents, 255, 262  
 determined by chemical analysis, 355  
 diseases affecting, 255, 261  
 factors determining, 80  
   in maintaining, 271  
   to be considered, 355  
 grain farming and, 344  
 home projects on, 353  
 how to test, 80  
 illustrated, 82  
 indicated by crop yields, 80  
 in relation to fertilizing elements, 187, 206  
   fertilizers, 206  
   grain farming, 344  
   liming, 229, 231, 250  
   soil organisms, 171  
   stock farming, 345  
   systems of farming, 343  
 lowered by acidity, 229  
 maintained in grain farming, 344, 347  
 maintained in stock farming, 345  
 maintaining, 206, 271  
 not restored by liming, 250  
 problems on, 354  
 regulated by liming, 250  
 surveys, exercises, 353  
 unfavorable factors, 83  
 work problems on, 353  
 field studies on, 27, 46, 73  
 formation of, 5-9, 16-22, 40-45  
 forming processes, 6-7  
 from limestone, acid, 242, 248  
 glacial, defined, 15, 18  
 grains. (See Particles)  
 heavy, defined, 15  
 how described, 22  
 humid vs. arid, 44, 378  
 improvement, general, 87  
   crop rotations for, 263-274  
   by legumes, 180  
   green manuring for, 194, 195  
   home projects on, 368  
   in clay management, 321  
   in marsh management, 294  
   in sand management, 310  
   in silt loam management, 325  
   liming, first step in, 230  
   rotations best for, 274  
 in dry climates, 44, 378  
 in humid climates, 44  
 kinds of, 14, 15, 24  
 lacustrine, 15, 21  
 leaching of, 349, 351  
 light, defined, 15  
 loess, defined, 15, 22  
 mapping, 22-25  
   exercises on, 27  
 management increase crops, 2  
   in England, 2  
   in Germany, 2  
   in France, 2  
 marine, defined, 15, 21  
 mechanical composition of, 15  
 mineral, defined, 41  
 moisture, 89-132. (See Soil water)  
   amount soils give up, 91  
   capillary rise of, 96  
   conservation of, 100, 313, 380  
   control of, 100  
   cultivation to conserve, 104, 313, 380  
 Soil moisture, factor in crop production, 92  
   forms of, 93  
   how held in soils, 93  
   importance of, in soil, 89  
   in relation to germination, 49  
   in soil medium, 12  
   laboratory exercises on, 105, 107  
   most important form of, 93  
   movement of, 95-98  
   mulches to conserve, 103, 104, 313  
   robbed by weeds, 104, 380  
   supply in soils, 98-100  
 mulch, cultivation to maintain, 104, 313  
   defined, 102  
   how conserves moisture, 103  
   laboratory exercises on, 105, 106  
   self-forming, 104  
   value during dry periods, 104  
   of, in dry-farming, 380  
   what constitutes a good, 103  
 needing phosphates, 199  
 needs, determining, 355  
   chemical analysis for, 355  
   factors to consider in, 355  
 of many kinds, 9, 14, 15, 24  
 of national interest, 1  
 organisms and fertility, 171. (See Soil bacteria)  
 origin of, 5  
 our nation's problem, 2  
 particles, names of, 11  
   composition of, 29, 30  
   not plant food, 61  
   size of, 11, 12  
 porosity of, exercises on, 106  
 relation to seeds, 49  
 rich, defined, 66  
 rocks in relation to, 39  
 series, defined, 24  
 sour, 45, 229  
 source of mineral elements, 35  
 standards for comparing, 72  
 structure, defined, 13  
   and mulch formation, 104  
   destroyed by plowing, 54, 322  
   illustrated, 13  
   in clay management, 322  
   organic matter relations, 266  
   renewed, 54, 322  
   rotation relations, 266  
   seed-bed relations, 54, 135  
   tilth relations, 54, 322  
 survey, 22-25  
 temperature, 48, 109  
   and germination, 49  
   drainage relations, 48, 109  
   field studies on, 60  
   laboratory exercises on, 57, 59, 132  
   of clay soils, 322  
   marsh soils, 302  
   sands, 309  
   plant-growth relations, 51, 77  
 texture, defined, 13  
   basis for soil classification, 13  
   clay of fine, 13  
   drainage relations, 120  
   dry-farming relations, 378  
   factor in capillarity, 66  
   in water-holding, 98, 99, 102  
   fertility relations, 40, 72, 81  
   influence on capillarity, 96, 97  
   laboratory exercises on, 26  
   liming relations, 247  
   percolation and seepage relations, 95

- Soil texture, plowing relations, 142, 147, 148  
 sand of coarse, 13  
 seed-bed relations, 54, 135, 155, 322  
 soil classes determined by, 14  
 mulch relations, 103, 104  
 tilth relations, 54, 135, 322  
 unchangeable, 13  
 tight, defined, 112  
 transported, defined, 15  
 transporting agents, 15  
 tropical, 45  
 type, defined, 24  
 washing. (See Soil erosion)  
 water, 89  
 laboratory exercises, 105, 106  
 (See Soil moisture)  
 weight of, 71  
 exercises on, 27  
 when formed, 5  
 why some deficient in K and P, 40
- Soybeans, elements removed by, 63  
 for green manuring, 192  
 for sands, 312, 316  
 illustrated, 193  
 response to liming, 233
- Spading disk harrow, 152
- Spray irrigation, 130
- Springs, why some dry up, 285
- Stock farming, defined, 343  
 crop rotation in, 329  
 grain and, compared, 343, 344  
 popularity of, 344, 345  
 soil fertility relations, 343
- Strawberries, elements removed by, 69
- Stubble land, defined, 138  
 plows for, 141  
 plowing, 138
- Sub-humid climate, defined, 42
- Sub-irrigation, 130
- Sub-main, tile, defined, 121
- Subsoil, defined, 11  
 plant-food elements in, 72  
 tight, defined, 112
- Subsoiling, 145, 147, 148  
 for sandy soils, 313
- Subsurface drainage, 113  
 covered drains for, 116, 117  
 open ditches for, 115
- Succession of crops, defined, 280
- Sugar beets, desirable type, 55  
 a heavy feeder, 64  
 elements removed by, 62, 67  
 for marsh soils, 305  
 for sands, 317  
 need potash, 263  
 response to liming, 233  
 root system of, 68  
 rotation for, 280  
 where grown, 280
- Sugar cane, rotation for, 280
- Sulfate of ammonia, 196  
 of potash, fertilizer, 202, 203
- Sulfur, defined, 30, 32  
 as fertilizing element, 33  
 function of, in plants, 56
- Summer fallowing, defined, 153  
 in rotation, 277
- Superphosphate fertilizer, 199
- Surface drainage, defined, 112  
 plow furrows for, 114  
 surface runs for, 114  
 use of spade for, 114  
 run, defined, 114, 123  
 with tile, 123, 124
- Swamp, defined, 39
- Sweet clover, illustrated, 193, 323  
 for alkali soils, 258  
 for clay soils, 323  
 for green manuring, 193  
 for soil improvement, 193 323
- Syenite, defined, 39
- Systems of farming, 343  
 in relation to fertility, 343-353  
 of tile drainage, 121, 122
- Tankage, fertilizer, 196
- Temperature. (See Soil temperature)
- Terracing, defined, 288
- Testing soils for needs, 355-368  
 (See under Fertilizers)  
 (See under Lime)
- Thomas slag, fertilizer, 197, 198
- Tile (drain), defined, 117  
 drainage, defined, 117, 126  
 better than open ditches, 122  
 for alkali soils, 131, 258  
 for alkali spots, 44, 111  
 for "bogus" spots, 302  
 for heavy clays, 322  
 for irrigated lands, 131  
 for marsh soils, 110, 304  
 for slopes, 95, 111  
 gridiron system of, 121, 122  
 herringbone system of, 122  
 in relation to toxins, 262  
 natural system of, 120, 121  
 parallel system of, 121, 122  
 profitable, 124, 125  
 systems of, 121  
 tools for, 118
- drains, explained, 117  
 better than ditches, 122  
 distance apart to lay, 119  
 how to cover, 119  
 how to make, 117, 119  
 how they work, 120, 124  
 laboratory exercises on, 133  
 must have fall, 117  
 protected outlets for, 122, 123  
 with surface runs, 123
- Tillage, general discussion, 135  
 in relation to toxins, 262  
 objects of, 137  
 of clay soils, 212  
 of dry-farming lands, 378, 380  
 of marsh soils, 295, 297  
 of sands, 313, 315  
 principles governing, 137  
 relation to erosion, 287  
 seed-bed preparation, 138  
 tools, 136-169
- Tilth, defined, 48  
 cultivation and, 135  
 factors determining good, 135  
 in development of good, 54  
 fertility relations, 356  
 field studies on, 60, 88  
 full meaning of good, 52-54  
 good, defined, 48  
 green manure and, 190  
 importance of good, 49  
 influences plant growth, 51  
 laboratory exercises on, 58, 59  
 liming favors, 230  
 of clay soils, 321  
 organic matter and, 266  
 poor, defined, 48  
 rotations to improve, 266  
 seeding and planting relations, 156
- Timothy, elements removed by, 63

- Timothy, not a soil robber, 65  
 where grown, 275
- Tobacco, a heavy feeder, 63, 64, 199, 203  
 phosphorus lost in growing, 267  
 response to liming, 233  
 rotations for, 276, 278, 280  
 stems as fertilizers, 202, 203  
 where grown, 277
- Toxin theory of infertility, 261
- Transported soils, 15
- Tropical soils, 45
- Truck crops and liming, 233  
 rotations for, 280  
 where grown, 281
- True clay, defined, 41
- Truog test for acidity, 234
- Turnips, as feeders, 63, 67  
 for clay soils, 325
- Unfertilized plot, value of, 370
- Vegetative period, defined, 49  
 activities in, 50  
 conditions and requirements, 50, 51
- Velvet bean, for green manure, 193  
 for sands, 310, 312, 316  
 for soil improvement, 310
- Vertical drainage, defined, 113, 124, 126  
 forms of, 124, 126
- Vetch, for green manuring, 193  
 for sands, 316  
 rotations for, 280
- Waste lime, 243
- Water, a part of soil medium, 12  
 amount crops require, 89, 90  
 soils give up, 91  
 held by peat, 94  
 by soils, 93, 98  
 available water in soils, 98  
 capillary, defined, 93  
 conservation and control, 100  
 forms of, in soil, 93  
 free, defined, 93  
 gravitational, defined, 93  
 hygroscopic, defined, 93  
 laboratory exercises on soil, 105, 106,  
 133, 185  
 limiting factor in dry farming, 92  
 limits yields in humid regions, 92  
 movements of soil, 94  
 percolation of, 95
- Water problems in farming, 92  
 required for germination, 49  
 required by plants, 89  
 too much is harmful, 109, 258, 260  
 why crops require, 89
- Water-holding capacity of soils, 98, 99  
 how to increase, 102  
 laboratory exercises on, 107
- Watermelon, response to lime, 233
- Water requirement of plants, 90  
 factors influencing, 91
- Water-table, defined, 113
- Weathering, defined, 6, 172  
 agents, 6, 7  
 continues indefinitely, 9  
 products of rock, 41
- Weed problem on marsh soils, 301
- Weeders, defined, 168  
 illustrated, 168, 315  
 light harrows for, 168
- Weeds, as moisture robbers, 104  
 controlled by liming, 230  
 controlled by clover, 78  
 exercises on, 87  
 field studies on, 107  
 for green manure, 195  
 how to kill, 164, 166  
 killed by shading, 78
- Weight of soils, 71
- Wheat, elements removed by, 63  
 production on decline, 1  
 rotation for, 275-277  
 where grown, 276, 277
- White alkali, defined, 44  
 grubs, 255
- Wind, a transporting agent, 15, 22  
 a weathering agent, 6  
 breaks in sand farming, 314
- Winter wheat, rotations for, 267, 279  
 where grown, 276
- Wire worm, 255
- Wood ashes, as fertilizer, 202, 203  
 for acid peats, 204  
 for marsh soils, 301  
 for mixed fertilizers, 211
- Yeast plants, illustrated, 171
- Yield, affected by temperature, 51  
 relation to cost expense, 369  
 to profits, 369  
 relatively low, 2





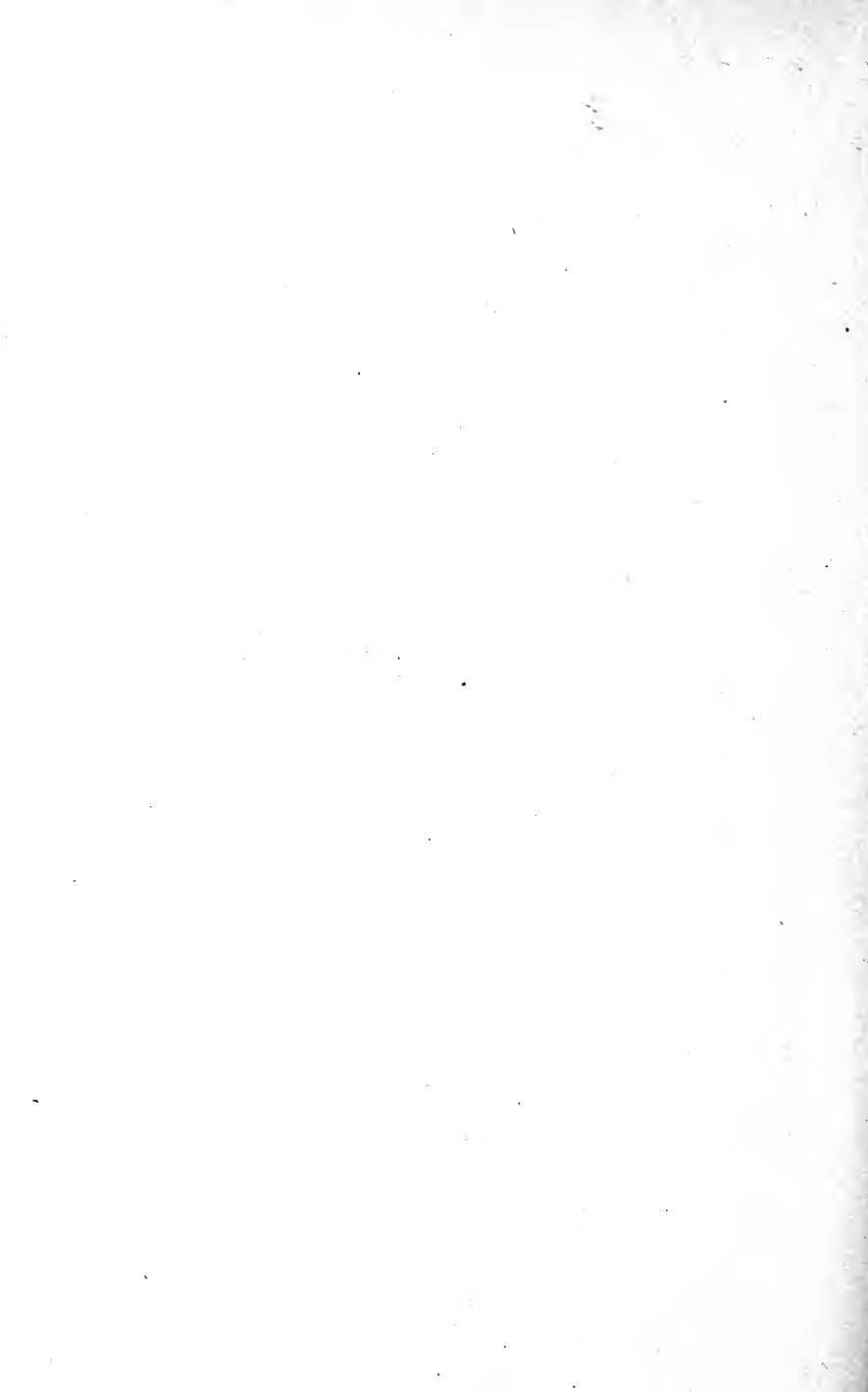





250

10

YC 47894

488002

5591

YD

UNIVERSITY OF CALIFORNIA LIBRARY

