

UC-NRLF

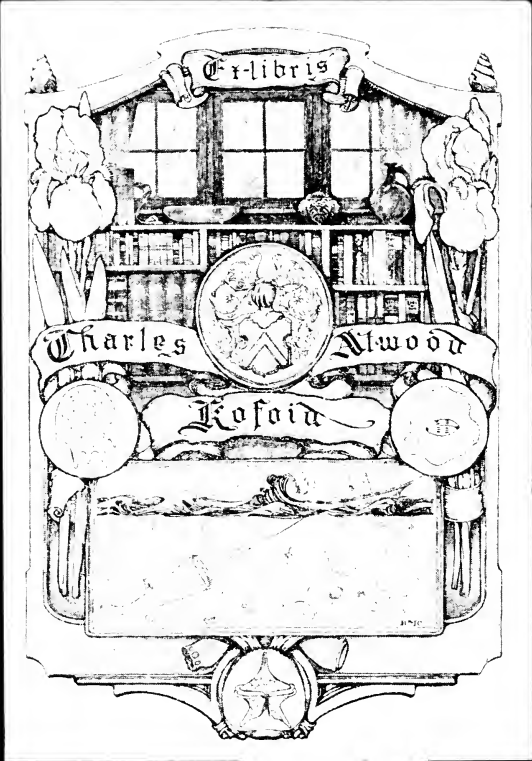

5B 76 707

YC 67110





THE LIBRARY
OF
THE UNIVERSITY
OF CALIFORNIA

PRESENTED BY
PROF. CHARLES A. KOFOID AND
MRS. PRUDENCE W. KOFOID



THE

PROGRESSIVE

MACHINIST

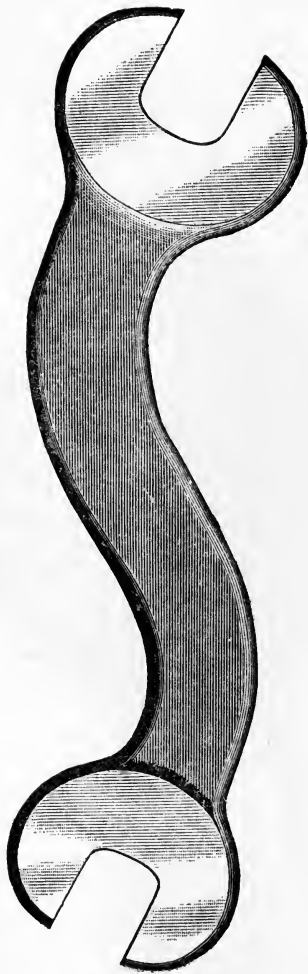

DEDICATION

This work is gratefully
dedicated by the author to the
memory of the late Gustave Kemmerling
M.E. of Berlin, my first instructor
in the noble art of which he
was a grand master.

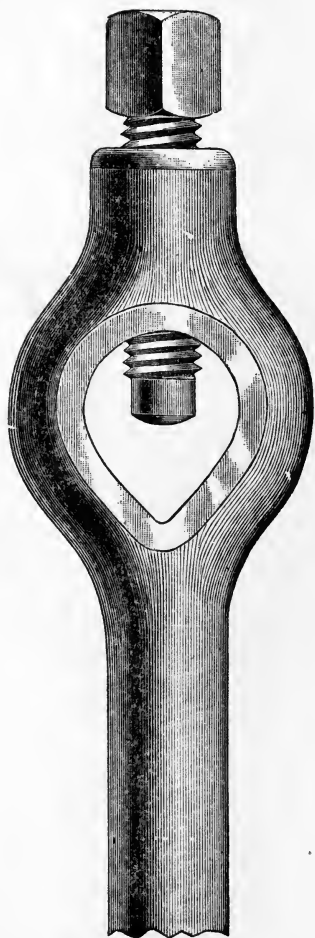

"By hammer and hand, all things do stand"

THE
**PROGRESSIVE
MACHINIST**

A PRACTICAL AND EDUCATIONAL
TREATISE, WITH ILLUSTRATIONS

BY
WILLIAM ROGERS



THEO. AUDEL & COMPANY

63 FIFTH AVENUE NEW YORK CITY.

COPYRIGHTED
1901-1903
by
THEO. AUDEL, & CO.

H375
1903

GENERAL CONTENTS.

Dedication—Titles—Copyright—Table of Contents—Plan of the Work—Preface—Introduction..... 1-26

MATERIALS.

Shop Motto—Preliminary Definitions--Definitions--Qualities of Matter—Iron, Steel, etc.—Various Metals, Alloys, etc., Arranged Alphabetically—Gravity and Tables—Three Laws of Motion—Historical Note, Strength of Materials and Table—Fatigue of Metals—Table of Melting Points of Solids—Useful Weights and Measures.... 27-72

DRAWING.

Introduction—Free-hand Drawing—Blackboard Sketches—Drawing Materials—Instruments—Outfit—Drawing Board—Tee-Squares—Triangles or Set-Squares—Dividers and Compasses—Drawing Scales—Two-foot Rule—Protractor Drawing Pens—Pencilng—Inking—Lettering Drawings—Dimensioning—Shading—Section-Lining—Reading Working Drawings—Problems in Geometrical Drawing—Points Relating to Drawing.. 73-123

GEARING.

Introductory—Definitions—Cog Wheels, Spur and Bevel Wheels—Mitre Wheel—Mortise Wheel—Rack and Pinion—Worm Gearing—Helical Wheel—Internal Gear Wheel—Designing Gears—Proportions of Parts—Cast Steel Wheels—Speed of Gear Wheels..... 124-139

BENCH AND VISE.

Tempering and Hardening Metals—Physical Properties—Definition of Terms—The Art of Tempering—I. Matthewson's Method—H. Woodruff's Method—American Machinist Rules—Grades of Steel—Cementation Process—Bessemer and Siemen-Martin Process—Case-Hardening—Annealing—Hand Tools—Machine Tools—Work Benches—Vise—Hammer—Scribers—Steel-Square—Cold Chisels—Files—Calipers—Straight-Edge—Center-Punch—Wrenches—Sledge and Anvil—Practical Use of the Foregoing—Surfacing—Red Marking—Hand Drilling—Broaching—Screw Cutting by Hand—Pipe Cutting.... 140-205

GENERAL CONTENTS.

TOOLS AND MACHINES.

Definition of Machine and Hand Tools—Portable Tools— Action of Machines—Classification of Machine Work— Turning and Boring—Planing Operations—Milling— Drilling—Grinding—Punching and Shearing.....	207-215
--	---------

THE LATHE.

Historical—Forms and Use of Foot Lathes—Hand Lathes— Chuck or Surfacing Lathe—Engine Lathe—Parts of the Lathe—Countershafts—Cutting Tools Used in the Lathe —Tool Room—Tempering of Lathe Tools Rule—Lathe Practice—Measuring Instruments—Chucks—Mandrels —Template—Lathe-Dogs—Centering—Driving Work Between Centers—Turning Work Between Centers— Lathe Speed—Chuck and Face-Plate Work—Drilling and Boring in the Lathe—Proportion of Parts of a Lathe—Summary.....	216-305
---	---------

TABLES AND INDEX.

Weight of Plate and Sheet Iron—U. S. Standard Gauge for Same—Weight of Flat Iron—Weight of Round Iron— Weight of Square Iron—Weight of Cast-Steel Bars— Comparison of U. S. Standard, Birmingham Wire, and Brown & Sharp's Wire Gauges—Decimal Equivalents of an Inch—Diameters, Circumferences and Areas of Circles.....	307-330
Index	335

ACKNOWLEDGEMENT.

In addition to credit given in the text to many persons and firms for information and illustrations, the author desires to especially mention with thanks Mr. Percival Marshall, M. E., editor of "The Model Engineer," London and New York, and Mr. Geo. Perrott, M. E., for drawings and valuable technical assistance.



PLAN
OF THE
WORK

There is no class of men who are more level-headed and competent to form correct opinions than intelligent well trained machinists, their work is often of such a character that it affords plenty of time to think.

PLAN OR OUTLINE OF THE WORK.

Every author has a preconceived plan upon which his work is based and it is essential that his plan shall be known to the student so that he may, to advantage, follow the instruction of the writer.

How many read the "preface" to their books? Again, how many know into how many divisions the book is divided and where they may find a certain subject, upon which they need information? It is in view of these facts that the following lines have been prepared, to aid in the better understanding, the scope and outline of the book.

In a work necessarily so limited as this many topics must be treated with extreme conciseness, but where space has been lacking for a free discussion of a subject, the elementary principles have had the preference, leaving the reader to continue what may be called a wider and philosophic observation, to a complete comprehension of the particular study.

The subject of this work relates to a true science, and the author has planned the work accordingly, *i. e.*, the orderly arrangement of all miscellaneous information into a classification that will permit the careful reader the ready use of the contents.

It has been the desire of the author to render the work attractive by illustrating the general principles and prac-

tice of the art by the use of language easy to be understood, as well as by many helpful cuts and diagrams.

Mathematical elements are woven into the whole work throughout as a foundation; tables, rules and examples are inserted wherever these can make the reading matter plainer.

To be a good mechanical draftsman is a long step in the path of scientific improvement, and skillful artists in this line are seldom out of employment; hence the part of the *Progressive Machinist* devoted to this subject will, it is to be hoped, be taken as meant, as an aid, cheerfully imparted and of permanent value.

In the preparation of the contents of the work the author has had two objects constantly in view: first, to make the Student thoroughly acquainted with the leading principles of the art underlying Machine Shop Practice; and secondly, to furnish him as much useful information as possible.

It is recommended that the reader shall consult the list of contents at the beginning of the work, for reference to subjects, and refer to the Index at the back of the work for particular findings. The latter may frequently be found under another letter where failure has been made in one; this is an advantage gained by the use of the cross index, *i. e.*, a subject is entered under more than one heading.

In conclusion, it may be stated that this work is designed somewhat as a school book, to be studied from beginning to the end, and at the same time as a book of ready reference through the use of the ample reference index.

PREFACE.

The author has before him five photographic groups of machinists' societies and the large group of American and English mechanical engineers, as they were to be seen at one of their recent annual reunions.

A study of these scores and scores of faces suggests a thought or two: 1, but few of them seem to equal "the days of the years of the life" of the author; 2, each and every man has undoubtedly stored in the recesses of his brain one or many items of useful knowledge pertaining to the mechanic arts, unknown to the author of this work which, notwithstanding, is aimed to be educational; 3, that if every art of mechanism were for the time obliterated and known on earth no more, these men, modest as they are, could restore in a few brief years every useful art and manufacture; 5, throughout the groups appears a wise gravity born of the combined brain and muscle work going with the higher class of mechanics.

It is to men represented by these photographic groups that the author appeals with profound respect for a kindly consideration of the contents of the work.

It is narrated of the good sculptor, Michael Angelo, that when at work, he wore over his forehead, fastened to his cap, a lighted candle, in order that no shadow of himself might fall on his work. It was a beautiful custom, and spoke a

more eloquent lesson than he knew. For the shadows that fall on our work—how often they fall from ourselves.

So, it will be the aim of the editor and compiler of these succeeding pages to keep in the shaded background allusions to those long years of personal experience which have gone never to return but upon whose gathered and garnered experience the value of the work must rest.

The contents of the book must, perforce, be its own justification; to be thorough and accurate is to be also honest, and to be all three, is worthy of the highest ambition, and such has been the endeavor of the author.

A book requires as much labor and careful thought as a complicated machine, and it often takes longer to produce it, and then, too, a reader wishes to know, first of all, what it contains, what ground it covers and what are its scope and limitations.

The *Progressive Machinist* is issued in the interest of those (1) who as yet are uninformed and are at the beginning of a career devoted to mechanic arts. (2) those who have once known the rules and practices of the machinist's art and have forgotten much of that they once painfully acquired. (3) For all whose extensive knowledge of machines and machine shop practice will be rendered more available by a classification or scientific arrangement.

Let it not be forgotten that "the man stands strongest who stands on his head," and that head is best filled that knows the most of the principles which underlie his life's calling.

Certain principles are fundamental; although knowledge has advanced natural laws have remained and will remain; application may have changed, but nature's decrees are lasting; a straight line is the nearest distance between two points no matter what comes in between or what means are used to connect them. That is the principle; that is the law. Cohesion of matter always remains. Gravity is everywhere and instantaneous.

To quote from a distinguished and well-known author:

"I have always divided men into two classes, professional and non-professional, to the disparagement of neither.

"Among non-professional men, I class those who carefully treasure every scrap of past experience, and who are guided by their accumulations of experience.

"Among the professional men, I class those, who, without any special attempt to gain experience themselves, are constantly and forever absorbing the experience of others. If the non-professional never did a certain thing he knows nothing about it. After he has done it, he gets one man's experience. . . . The professional man without intending to do a certain thing may have a thorough knowledge of the world's experience in that thing. To him the books bring the life-time experience of ten thousand lives. Knowledge of others' failures will divert his thoughts and acts into original channels. The non-professional leaves on record the experience of one short life and the professional man gathers in thousands of these."

It is to be hoped that in the educational lines attempted to be followed in *The Progressive Machinist*, each of these two classes will be benefited.

The term machinist signifying a builder of machinery is now of less scope of meaning than formerly; at no distant period the machinist was to-day a lathe hand, to-morrow a vise hand; he was required to be alike skillful in working upon both wood and metal, a pattern maker and a founder;

he was both engineer and a millwright, but it is not so in this age of specialization.

But it is true now as always that the skill which is exercised by a machinist is an art which is taught from man to man, and it is a fact that there is always more or less interchange of experience and moving about of workmen, which enables others in other lines of work to know what is being done, and thus permanent improvement is made year by year.

The most expensive machine is the man himself; the saving in labor is the chief item in economical shop practice. "The man behind the gun" wins the victory; the man behind the machine is a captain of modern achievement; an epic of our times might well be, as Carlyle wrote, "not arms and the man, but tools and the man."

"The human body is an epitome in Nature of all mechanics, all hydraulics, all architecture, all machinery of every kind. There are more than three hundred and ten mechanical movements known to mechanics to-day, and all of these are but modifications of those found in the human body. Here are found all the bars, levers, joints, pulleys, pumps, pipes, wheels and axles, ball and socket movements, beams, girders, trusses, buffers, arches, columns, cables and supports known to science. At every point man's best mechanical work can be shown to be but adaptations of processes of the human body, a revelation of first principles used in Nature." *

“Make the most of time,” says Goethe, “it flies so fast. Yet method will teach you to win time.” Talleyrand remarks, “Methods are the masters of masters.”

If one desires to get on he will have to work, and if the work is to be a success it must be done in an orderly, systematic manner; the proverb has it, “Raw haste is half-sister to delay.”

“Adopt the pace of Nature,” says Emerson, “her secret is patience.” “Everything comes if a man will only wait,” is a saying of Lord Beaconsfield, England’s great Prime Minister. “Imitate time,” wrote the French essayist, Joubert. “It destroys slowly; it undermines, wears, loosens, separates; it does not uproot.”

Dr. Le Bon says, “Century after century our departed ancestors have fashioned our ideas and sentiments, and in consequence all the motives of our conduct. The generations that have passed away do not bequeath us their physical constitution merely; they also bequeath us their thoughts. We bear the burden of their mistakes, we reap the reward of their virtues.” It is thus with shop management; we are the inheritors of a hundred generations of such men as Newcomen, Watt, Stephenson, Arkwright, Maudslay, Fairburn, Whitworth, and thousands of others.

Hence, 1, work with thoughtful system; 2, work with patient deliberation; 3, work in the place where one is providentially living; 4, learn underlying principles; 5, remember what Ben Franklin said one hundred and fifty years

ago, "He that idly loses five shillings' worth of time, loses five shillings and might as prudently throw five shillings into the river."

In closing the author has yet to repeat a well-approved shop adage, "A grain of showing is worth an ounce of telling."



INTRODUCTION

If you want the best out of me don't abuse me, but appeal to me as a man, and if it is in me I will measure up to your requirements.

Is not the same thing true of you, and if it is true of you is it not true of any man

INTRODUCTION.

Machinists must know the elements of several trades in order to be masters. No one man can be expert in all branches, and while it is now universally admitted that a man does well to excel in one, the steps which lead to the top are built of those simple things which are of service, alike to the student and to the master. It is almost a necessity to be posted upon the history of the development of machines and their inventors; still more is it to be thoroughly instructed in the meaning and use of shop words and terms.

There are but five sources of original power: 1, Water power; 2, Wind power; 3, Tide power; 4, The power of Combustion; 5, The power of Vital Action. Gravitation, Electricity, Galvanism, Magnetism and Chemical Affinity can never be practically employed as original sources of power.

Machines are divided into *simple* and compound; the former are six in number: 1, The Lever; 2, The Wheel and Axle; 3, The Pulley; 4, The Inclined Plane; 5, The Screw; 6, The Wedge.

Compound machines are formed from two or more simple machines. *Tools* are the simplest implements of art; these when they become complicated in their structure become

machines; and machines, when they act with great power, take the name, generally speaking, of *engines*—as the pumping engine.

There are ten arithmetical figures—how small their number—1, 2, 3, 4, 5, 6, 7, 8, 9, 0; observe the small space it takes to print them.

There are twenty-six letters in the alphabet—a, b, c, d, e, f, g, h, i, j, k, l, m, n, o, p, q, r, s, t, u, v, w, x, y, z; how insignificant they are when put down in order.

There are, too, only some sixty or eighty elementary or simple substances—such as iron and copper—in the world, under it, or in the air. These are arranged in alphabetical order:

Aluminium	Glucinum	Rhodium
Antimony	Gold	Rubidium
Arsenic	Hydrogen	Ruthenium
Barium	Indium	Samarium
Beryllium	Iodine	Scandium
(See Glucinum)	Iridium	Selenium
Bismuth	Iron	Silicon
Boron	Lanthanum	Silver
Bromine	Lead	Sodium
Cadmium	Lithium	Strontium
Cæsium	Magnesium	Sulphur
Calcium	Manganese	Tantalum
Carbon	Mercury	Tellurium
Cerium	Molybdenum	Terbium
Chlorin	Neodymium	Thallium
Chromium	Nickel	Thorium
Cobalt	Niobium	Tin
Columbium	Nitrogen	Titanium
(See Niobium)	Osmium	Tungsten
Copper	Oxygen	Uranium
Didymium	Palladium	Vanadium
Erbium	Phosphorus	Ytterbium
Fluorin	Platinum	Yttrium
Gallium	Potassium	Zinc
Germanium	Praseodymium	Zirconium

And yet:—

From the ten figures all the vast and varied processes of calculation may be made.

From the twenty-six letters may be formed books, periodicals and writings sufficient to fill the world.

Now, too, from these sixty or eighty elementary substances are made not only the solid earth, but every minute body alive or without life, all trees and fruits, water, the gases, and all machines and materials used in and about them.

The first lesson to be learned from these examples is this—that every one capable of thought may learn the names and some of the leading uses of figures, of the alphabet and of the simple substances of which the earth, and perhaps the vast universe, is formed and exists.

The second lesson is the rather unpleasant truth that no human intellect ever had the power of compassing the innumerable details to which, by combination, they may be extended.

Other lessons—of humility and such like—from a contemplation of the conditions named may be drawn, but one other will suffice; (3) that success in the brief span of a single human life lies along the line of concentration of thought and effort in special endeavors, united with an honest and truthful judgment of the elementary knowledge open to all aspirants for learning.

A million years of prolonged life and study allowed to a million of scholars, each pursuing a separate path of research, would not compass a millionth part of the knowledge to be acquired in the development to their full extent of the ten numerals, of the twenty-six letters and the sixty or eighty elementary substances.

Thus, a traveller visiting a town, could take in a second of time a general survey, so that he could ever after say with truth, I have seen Paris or New York or Yokohama; this would be true, especially if the view was first had from an eminence which allowed the whole sweep of horizon to be embraced in the flash of an eye-lid.

But the traveller to the cities named would need months and years to gain the knowledge necessary to become thoroughly an active, useful citizen of either of them.

In addition, there are to be considered what are called the Laws of Nature, the practical adoption of the law of Demand and Supply and the general fitness of things, leaving out of the question the chapter of accidents so evident in all human endeavor, so we are to be forgiven if in the preparation of these volumes we keep prudently within safe and simple limits in explaining, for the advantage of the student the subjects selected, but—

Always keeping in view the order of progression natural to healthy advancement.

A rectangular metal plate with a double-line border. Four circular fasteners are positioned at the corners. The word "MATERIALS" is centered in a bold, outlined, sans-serif font.

MATERIALS

You can judge much better of the goodness of
the cloth, if you know the quality of the wool.

MATERIALS.

PRELIMINARY DEFINITIONS.

The earth may be regarded in the light of a vast physical machine and knowledge of it may be conveniently divided into two branches, 1, what is known of its structure—including the composition, its material parts; 2, its method of working.

Much of the work will be devoted to the latter, but first it is essential to know as much as possible of the matter entering into all work; hence the following definitions.

In the accompanying sections, some of the properties of iron and steel, as employed in the construction of machinery and tools are given. It is, therefore, desirable that the meanings applied to the various terms used should be clearly understood. Some of the definitions are briefly as follows:

MATTER OR SUBSTANCE may be defined as whatever occupies space as metals, water, air; or again, matter is any collection of substance existing by itself.

Matter appears to us in various shapes, which, however, can all be reduced to two classes, namely, solids or fluids.

Whatever is composed of matter may be termed material; raw material is unmanufactured substance, as iron ore is the raw material of pig iron and pig iron is that of cast iron.

ELEMENT—This word denotes a substance incapable of being resolved by any known process into simpler substances.

MATERIALS.

A PROPERTY OF A THING is what belongs especially to it as its own peculiar possession, in distinction from all other things; when we speak of the qualities or properties of matter, *quality* is the more general; *property* the more limited term.

A *quality* is inherent; a property may be transient; those qualities manifested by all bodies (such as impenetrability, extension, etc.,) may be called general properties of matter, while those peculiar to certain substances or to certain states of those substances (as fluidity, malleability, etc.,) are termed specific properties.

A SOLID offers resistance both to change of shape and to change in bulk; a *fluid* is a body which offers no resistance to change of shapes; fluids, again, can be divided into liquids and vapors or gases.

A LIQUID can be poured in drops while gas or vapor cannot. It is important to note that experiment proves that nearly every substance becomes a gas or vapor, at a sufficiently high temperature; example, when iron is "burnt" a part of it has gone into vapor.

A METAL is a simple or elementary, shining, opaque body or substance having a peculiar lustre, known as the metallic lustre, insoluble in water, fusible by heat and a good conductor of heat and electricity. Many of the metals are also malleable or extensible by the hammer and some of them extremely ductile.

NOTE.—"A Metal is an Elementary Substance, or one which, in the present state of Chemical Science is one undecomposable, and which possesses Opacity, Lustre, Conductivity for heat and electricity and plasticity, or capability of being drawn, squeezed or hammered with change of shape but no loss of continuity. Metals which possess all these qualities, although in varying degree, are Gold, Silver, Copper, Iron, Lead and Tin. These metals have a high specific gravity; the lightest of the above, tin, is over seven times as dense as water."

—(C. D.)

MATERIALS.

TENSILE STRENGTH is equivalent to the amount of force which, steadily and slowly applied in a line with the axis of the test piece, just overcomes the cohesion of the particles, and pulls it into separate parts.

CONTRACTION OF AREA is the amount by which the area, at the point where the specimen has broken, is reduced below what it was before any strain or pulling force was applied.

ELONGATION is the amount to which the specimen stretches, between two fixed points, due to a steady and slowly applied force, which pulls and separates it into parts. Elongation is made up of two parts; one due to the general stretch, more or less, over the length; the other, due to contraction of area at about the point of fracture.

SHEARING STRENGTH is equivalent to the force which, if steadily and slowly applied at right angles, or nearly so, to the line of axis of the rivet, causes it to separate into parts, which slide over each other, the planes of the surface at the point of separation being at right angles, or nearly so, to the axis of the rivet.

ELASTIC LIMIT is the point where the addition to the permanent set produced by each equal increment of load or force, steadily and slowly applied, ceases to be fairly uniform, and is suddenly, after the point is reached, increased in amount. It is expressed as a percentage of the tensile strength.

TOUGH.—The material is said to be “tough” when it can be bent first in one direction, then in the other, without fracturing. The greater the angles it bends through (coupled with the number of times it bends), the tougher it is.

MATERIALS.

DUCTILE.—The material is “ductile” when it can be extended by a pulling or tensile force and remain extended after the force is removed. The greater the permanent extension, the more ductile the material.

ELASTICITY is that quality in a material by which, after being stretched or compressed by force, it apparently regains its original dimensions when the force is removed.

FATIGUED is a term applied to the material when it has lost in some degree its power of resistance to fracture, due to the repeated application of forces, more particularly when the forces or strains have varied considerable in amount.

MALLEABLE is a term applied to the material when it can be extended by hammering, rolling, or otherwise, without fracturing, and remains extended. The more it can be extended without being fractured, the more malleable it is.

WELDABLE is a term applied to the material if it can be united, when hot, by hammering or pressing together the heated parts. The nearer the properties of the material, after being welded, are to what they were before being heated and welded, the more weldable it is.

COLD-SHORT is a name given to the material when it cannot be worked under the hammer or by rolling, or be bent when cold without cracking at the edges. Such a material may be worked or bent when at a great heat, but not at any temperature which is lower than about that assigned to dull red.

HOT-SHORT is when the material cannot be easily worked under the hammer, or by rolling at a red-heat at any temperature which is higher than about that assigned to a

MATERIALS.

red-heat, without fracturing or cracking. Such a material may be worked or bent at a less heat.

TENACITY OR THE POWER OF COHESION is that resistance which bodies exhibit when force or weight is applied to tear asunder, in the direction of their length, the fibres or particles of which they are composed. Tenacity results from the attraction of cohesion which exists between the particles of bodies, and the stronger this attraction is the greater is the tenacity of the body; tenacity primarily means to "hold fast;" cohesion "to stick."

RESISTANCE may be understood as meaning the act of "springing back" or rebounding or the work given back by a spring after being strained.

COEFFICIENT is that which unites in action with something else to produce a given effect; that which unites its action with the action of another.

STRESS AND STRAIN—Any breaking or bending pressure applied to a body or substance is called a *stress*, its effect on the piece a *strain*; briefly, then, the strength of a solid piece or body is the total resistance it can oppose to strain in that direction.

Materials are exposed to four different kinds of strain.

1. They may be torn asunder; the strength of a body to resist this kind of strain is called its resistance to tension, or absolute strength.

2. They may be crushed or compressed in the direction of their length as in the case of columns.

MATERIALS.

3. They may be broken across; the strength of a body to resist this kind of strain is called its lateral strength.

4. They may be twisted or wrenched as in the case of axles or screws.

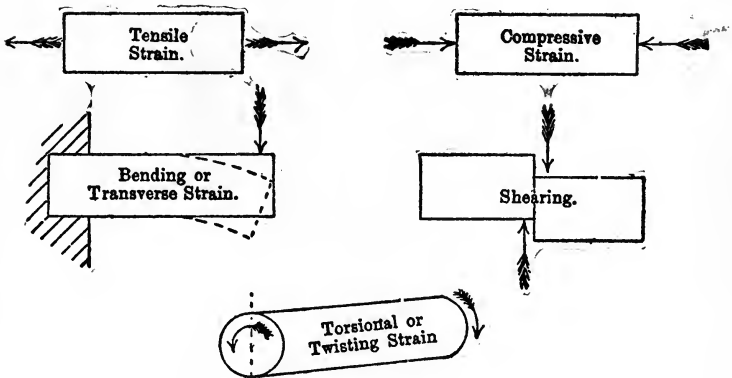



IRON, STEEL

AND

METALS



There has been an Iron Age this is the Age of Steel.

IRON, STEEL, ETC.

IRON is one of the elementary metals, and too well known to require a lengthy description; of all metals none plays so important a part in civilizing, mechanical advance, as iron; it is obtained from ores in which it is combined with earthy or stony substances and frequently with carbon, phosphorus, sulphur, arsenic, magnesia, etc.; in fact, iron is never found in its native condition, chemically pure, nor is any iron manufactured in a large way found to be free from impurities.

IRON is put upon the market in three forms:

1. Cast iron.
2. Wrought iron.
3. Steel.

VARIOUS IRONS—Different names are given to iron as needed to describe its size, form, quality or use; thus—gossamer iron—sponge iron—hoop, band, scroll, tee, groove, plate, bar, angle, flat, rod, sheet, hexagon, galvanized, horse shoe, nailrod, scrap iron.

CAST IRON, is iron which has been melted and cast; that is run into a mold in which it assumes the desired form; it is inflexible, unyielding in its nature, it melts at 1960° Fahrenheit, and its specific gravity is 7.21; when broken it shows a granular fracture.

HISTORICAL NOTE.—Iron was first made in Asia and North Africa and its use and manufacture can be traced to the earliest ages of antiquity. Tubal Cain, who was born in the seventh generation from Adam, is described in the Revised Version of the Scriptures as "the forger of every cutting instrument of brass and iron."

GOSSAMER IRON the wonderful product of the Swansea Iron Mills, is so thin that it takes 4,800 sheets piled one on the other to make an inch in thickness.

IRON, STEEL, ETC.

PIG IRON is distinguished in "the trade" by numbers, according to their relative hardness.

No. 1 is the softest iron, possessing in the highest degree the qualities described as belonging to gray iron. It has not much strength, but on account of its fluidity when melted, and of its mixing advantageously with other kinds of iron, it is of great use to the foundry.

No. 2 is harder, closer grained, and stronger than No. 1. It has a gray color and considerable lustre.

No. 3 is still harder. Its color is gray but inclined to white. It has considerable strength, but is principally used for mixing with other kinds of iron.

No. 4 is bright iron. No. 5 is mottled iron. No. 6 is unfit for general use by itself.

The quality of iron, in the pig, is decided by breaking the pig and examining the fracture. A medium-sized grain, bright gray color, lively aspect, fracture sharp to the touch, and a close compact texture, indicates a good quality of iron. A grain either very large or small, a dull, earthy aspect, loose texture, dissimilar crystals mixed together, indicate an inferior quality.

MALLEABLE IRON is made from pig iron low in silicon, sulphur and phosphorus, and from which the carbon has

NOTE.—Pig iron, according to the proportion of carbon which it contains, is divided into Foundry iron, and Forge iron.

There are many varieties of cast iron, differing from each other by almost insensible shades. The two principal divisions are gray and white, so called from the color of the fracture, when recent.

Gray iron is softer and less brittle than white iron. It is to a slight degree malleable and flexible, can be easily drilled and turned in the lathe, and does not resist the file. It has a brilliant fracture, of a gray, or sometimes a bluish-gray color; the color is lighter as the grain becomes closer, and its hardness increases at the same time.

White iron is very brittle and resists the file and the chisel. The fracture presents a silvery appearance, generally fine-grained and compact.

IRON, STEEL, ETC.

subsequently been largely removed by annealing at a red heat in iron ore, mill scale or some other porous or infusible substance.

WROUGHT-IRON is iron which can be worked into form by rolling or forging; it can be welded, it is flexible and malleable; it melts at 2912° Fah.; it has a specific gravity of 7.74; when fractured it shows a fibrous nature; it is weldable at 1500 or 1600° Fah.

There is an enormous wrought-iron pillar in India, near Delhi, which weighs 10 tons, and is said to be 1,800 years old. The manufacture of cast steel in India can be traced back for over 2,000 years.

STEEL—The term steel has always been more or less indefinite in meaning, so that it is generally necessary to add some qualifying adjective, in order that the nature of the material under consideration may be understood. Within recent years, however, the causes of the differences between the various kinds of steel have been studied in a manner which has enabled metallurgists to speak with some degree of precision concerning them.

The shortest definition of steel is to say it is refined or nearly pure iron, with a certain per cent. of added carbon. Steel may be made by two methods: (1) by adding carbon to wrought-iron, called *cementation process*, and (2) by removing carbon from cast iron as in the Bessemer process.

The name steel includes all varieties of iron except malleable iron, containing less than 1.5 per cent. of carbon; it may have been fused as in crucible steel and mild steel.

NOTE.—A bar of iron that contains flaws, blisters, etc., or for any other reason is not of uniform structure or density throughout, though no foreign substance be mixed with the iron, is said to be *non-homogeneous* or *unhomogeneous*

IRON, STEEL, ETC.

Or it may have been prepared in the solid condition, as in blister steel. When the steel has less than .5 per cent. of carbon it is called mild steel, when more, hard steel. When fractured the appearance is from granular to fibrous as the steel is of every variety from hard to mild or soft. Its specific gravity also varies from 7.70 to 7.90, and it melts at 2500° Fah.

Steel may be distinguished from iron by its fine grain, and its susceptibility of hardening, by immersing it when hot in cold water.

The best steel possesses the following characteristics: heated to a redness and plunged into cold water, it becomes hard enough to scratch glass and to resist the best files; the hardness is uniform throughout the piece. After being tempered, it is not easily broken, welds readily and does not crack or split. It also bears a very high heat, and preserves the capability of hardening after working; the grain is fine, even and homogeneous, and it receives a brilliant polish.

BESSEMER STEEL is made by pouring melted cast iron into a vessel called a "converter," through which a blast of air is forced; by this means the impurities are burnt out, and comparatively pure iron remains. To this then is added a certain quantity of *spiegeleisen*, which is a compound of iron, carbon and manganese; after this is done, the converter is tilted up, and the molten metal is cast into ingots.

SIEMEN-MARTIN STEEL is made by melting cast iron and wrought iron, or cast iron and certain kinds of iron ore together on the hearth of a reverberating gas furnace.

IRON, STEEL, ETC.

CAST STEEL is the finest kind of steel. It is known by a very fine, even, and close grain, and a silvery and homogeneous fracture. It is very brittle, and acquires extreme hardness, but is difficult to weld without the use of flux. Other kinds of steel have a coarser grain and are less homogeneous, are softer, less brittle and weld more easily.

CRUCIBLE CAST STEEL is used for tools, *i. e.*, tool steel—so-called—is cast from a crucible. A crucible is a melting pot generally made from plumbago.

MANGANESE-STEEL is an alloy of iron and manganese, containing a high percentage of carbon; it has great tensile strength and toughness combined with great hardness which cannot be softened and therefore limits its use; it can only be machined with great difficulty.

NICKEL STEEL is used with much success as a material for parts of marine engines and boilers. Owing to its ability to resist the action of salt water it is found to be superior to other kinds of steel for marine construction. Hollow shafts in the ocean "greyhounds" are found to be much stronger when made of this alloy than when made of any other kind of steel.

BLISTERED STEEL is prepared by the direct combination of iron and carbon. The process is to take the best bars and plates of wrought iron and expose them in a converting furnace for seven or eight days, to a medium temperature, while in contact with powdered charcoal so as to

NOTE.—In reading the percentages of carbon, phosphorus, etc., as given in technical papers and books of instruction, the reader is supposed to know that 1.5 per cent. means $1\frac{1}{2}$ parts in 100 or say again, .05 per cent. makes five parts in 100 or $1\frac{1}{20}$ part. This is told in decimals in arithmetic, but repeated here for the guidance of the incautious student.

IRON, STEEL, ETC.

totally exclude the air. The bars, on being taken out, exhibit in the fracture a uniform crystalline appearance. The degree of carbonization is varied according to the purpose for which the steel is intended.

SHEAR STEEL is generally made from blistered steel, refined by piling into fagots which are brought to a welding heat in a reverberatory furnace, hammered and rolled again into bars. This operation is repeated several times to produce the finest kind of shear steel. The name is derived from the fact that this variety of steel was used in England for shears.

THE PROCESS of converting cast into malleable iron consists in melting the pig metal in a reverberatory furnace, where the flame is made to act directly on the metal, keeping it exposed to a great heat, and constantly stirring the mass, thus bringing every part of it evenly under the action of the flame until it loses its carbon. It then loses its fluidity, and is formed into a puddler's ball. This is the point or connecting link between cast and malleable iron. After the puddler's ball has been formed, it is passed to a heavy squeezer, or steam hammer,—most frequently the former, the object being to press out, as perfectly as possible, the liquid cinder which the ball contains, when it is ready to be rolled or hammered.

NOTE.—*Attractive and Repellent Forces.*—If we take a piece of iron and attempt to pull it to pieces, we find that there is a force which holds the molecules together and resists our efforts. If we try to compress the metal, we find that there is a force which holds the molecules apart and resists our efforts as before. If, however, we apply heat, the iron expands and finally melts. So, also, if we heat a bit of ice, the attractive force is gradually overpowered, the solid becomes a liquid, and at last the repellent force predominates and the liquid passes off in vapor. In turn, we can cool the vapor, and convert it back successively into water and ice. We thus see that there are two opposing forces which reside in the molecules—an attractive and repellent force, and that the latter is heat.

IRON, STEEL, ETC.

While hot, it is generally passed between the rolls several times, and drawn into a bar about 5 inches wide and 3 inches long; this is called muck bar.

To refine it they are cut with a strong pair of shears into such lengths as are best adapted to the size of the bar or sheet required. The sheared bars are then piled one on the other, according to the quantity of metal necessary to make the finished piece. They are then brought to a welding heat in the heating furnace, and passed between the finishing rolls until drawn to the proper size.

NOTE.—“*Cast iron usually contains over 3 per cent. of carbon; cast steel anywhere from 0.06 per cent. to 1.50 per cent., according to the purpose for which it is used; wrought iron from 0.02 per cent. to 0.10 per cent. The quality of hardening and tempering which formerly distinguished steel from wrought iron is now no longer the dividing line between them, since soft steels are now produced which, by the ordinary blacksmith's tests, will not harden. All products of the crucible, Bessemer, and open-hearth processes are now commercially known as steel.*”—W. KENT.

VARIOUS METALS, ALLOYS, ETC., ARRANGED ALPHABETICALLY.

ALLOY is an artificial compound of two or more metals combined while in a state of fusion, as of copper and tin which form an alloy called bronze.

ALUMINUM is a metal of white silver color and brilliant luster, very malleable, ductile and a good conductor of heat and electricity. It melts at about 1160° Fah. Its most remarkable features are, (1) its low specific gravity, about $\frac{1}{3}$ that of iron, (2) its strength, and (3) it does not tarnish in the air; it is non-poisonous; it is used in machinery and alloys, and in apparatus where lightness and strength are required. Nickel-aluminum is the term used to describe an alloy of these two metals.

Five per cent. of copper, nickel or manganese or 30 per cent. of zinc added to aluminum make strong metals, as rigid as bronze, yet only one-third as heavy. Such light, strong, good casting and machining alloys have an extremely large field of usefulness.

Aluminum is the coming metal; it is found in inexhaustible quantity in common clay. When the iron fields and copper districts have yielded their last ton of metal, the world will progress with ease and comfort with this now rare product. Few of the readers of this book will, it is almost certain, reach the "Aluminum Age."

VARIOUS METALS, ALLOYS, ETC.

AMALGAM—This term signifies a mixture of metals, as a compound of quicksilver with another metal. Amalgams are used for cold-tinning, water gilding and for the protection of metals from oxidation or rusting, etc.

ANTIMONY is a metal of a white color and bright luster, and does not readily tarnish; it is a less perfect conductor of heat and electricity than most true metals and also differs from them in being brittle. It melts at 842° Fah., and is 6.7 heavier for the same bulk than water; it is largely used in alloys, particularly type metal, Babbitt and various anti-friction metals.

ASBESTOS is a fibrous mineral which resists heat, moisture and generally acids; its fibres are flexible and elastic; it is used for packing steam joints, piston-rods, etc. Reduced to a powder it is soft to the touch and makes a good cement for protecting heated surfaces.

BABBITT—This is an alloy composed of tin, copper and antimony. Any anti-friction metal has now come to be known as "Babbitt metal." Formerly the alloy originated by Isaac Babbitt was used for all purposes, but there is no one composition that will bring equally good results in all kinds of machinery. A metal designed to do the best service under heavy pressure will not be the best metal for bearings subjected to high speed.

BISMUTH is a metal of a peculiar light reddish color, highly crystalline, and very brittle; it is used in alloys with tin and lead, which fuse at a temperature less than that of boiling water and steam, under pressure, *i. e.*, such an alloy as is used in what are called "Safety Plugs," put in the shells of steam boilers to indicate low water.

VARIOUS METALS, ALLOYS, ETC.

BRASS is an alloy composed of copper and zinc in different proportions; it is generally harder than copper and wears better than that metal; it can be rolled into sheets or hammered into any shape, and drawn into fine wire; it turns easily in the lathe; it melts at 1650° Fah. Brass is of different degrees of hardness, according to the proportion of the alloys.

BRONZE—This is the name given to alloys which contain about 80 to 90 per cent. of copper, thus: Manganese Bronze contains 88 per cent. of copper. Phosphor Bronze contains 80 per cent. of copper.

CORUNDUM is a mineral substance found native in a crystalline state; in hardness it is next to the diamond; it is of various colors, the transparent varieties being prized as gems. Emery is granular corundum more or less impure. As an abrasive corundum is unexcelled. Its diamond-like hardness, brittleness and sharpness give it its long lasting qualities.

COPPER is a well-known metal, distinguished from all others by its red color; it is one of the most widely diffused metals. In two regions this metal is mined in its native state, namely, on the south shore of Lake Superior, and in Bolivia, South America. Copper is used for electrical purposes, on account of its high conductivity; it melts at 1996° Fah., and its specific gravity is 8.8; copper can be rolled, drawn or wrought; it turns easily in the lathe.

DELTA is an alloy of three metals; delta signifies three-sided or triangular. Its component parts are copper, zinc and iron. Delta is non-corrosive, and capable of high polish; it can be cast, forged, stamped and rolled; it has

VARIOUS METALS, ALLOYS, ETC.

great strength and toughness; when rolled it considerably exceeds the tensile strength of rolled bar iron. For mines it presents advantages from its resistance to acid waters.

DROSS is the name generally used to define the impurities or foreign matter or refuse which separates from molten metal and rises to the surface.

EMERY is a granular mineral substance and belongs to the species corundum; it is not, however, pure corundum, but is mixed with magnetic or hematite ores; it is principally used in grinding and polishing stone, metal and glass surfaces; for this purpose the stone is crushed into powder and attached to paper, cloth, wood.

GLASS is an inorganic substance, the result of the fusion of silica, soda, lime, potash, etc. Glass, such as used for window panes, is produced by the fusion at a very high temperature of purified white sand, lime, sulphate of soda, arsenic, manganese, salt cake and cullet or broken glass.

GOLD is a precious metal, remarkable for its unique yellow color, luster, high specific gravity and freedom from liability to rust or tarnish; it melts at 2000° Fah., and its specific gravity is 19.2; it resists the action of all ordinary acids.

GUN METAL or *Bronze* is an alloy of 8 parts copper and 1 part tin; principally used in making bells, in the manufacture of cannon and also machinery requiring extra strength.

VARIOUS METALS, ALLOYS, ETC.

LEAD is a metal remarkable for its softness and durability; it belongs to the white metals, but has a decided bluish gray tinge; the fresh cut surface is lustrous, but soon becomes dull from exposure. Lead is easily cut with a knife and is very malleable; it can be rolled into sheets, but will not draw into wire; it is largely used for pipes and steam joints. It melts at 618° Fah., and its specific gravity is 11.38.

LIMESTONE is a rock used largely in purifying cast iron in the cupola or furnace.

MANGANESE is a metal not used in its pure state. When alloyed with iron it is called spiegeleisen or ferro-manganese.

MINERALS—This word is derived from mine, hence primarily, minerals are metallic or other ores procured by digging.

A mineral is in almost every case a solid body and besides its chemical composition has other characteristics, as specific gravity, hardness, fracture, tenacity, luster, color and fusibility.

MERCURY is a metal of a silver white color and brilliant metallic luster, unique in that it is fluid at all ordinary temperatures; its chief use is in treating gold and silver ores, and its peculiar qualities are availed of in the thermometer and barometer. Mercury freezes and becomes solid at about, *i. e.*,—40° Fah.

MUNTZ METAL is an alloy of three parts copper, two parts zinc; it is largely used for sheathing timber ships' bottoms to preserve them from the action of salt water; it can be easily rolled or forged, and differs from common brass in being malleable when hot.

VARIOUS METALS, ALLOYS, ETC.

NICKEL is a metal which is closely allied to iron and is of a slightly lighter color; the ore of nickel is diffused generally throughout the world but nowhere in abundance; nickel is an ingredient in valuable alloys such as German silver, coinage, nickel steel, nickel plating, etc.

Nickel is very difficult of fusion, melting at about 3000° Fah. Nickel is attracted to the magnet and may be made magnetic like iron.

ORE is a name or term used to define rock or metallic mineral which is of economical or mercantile value.

PLATINUM is an important although rare metal; it is not found as an ore, but is alloyed with other metals in its native state; it is only surpassed in ductility by gold and silver; it is infusible in the strongest heat of a blast furnace, and is used for the connecting wires in incandescent electric lamps. The annual world's supply of this metal is reckoned in ounces. Over 90 per cent. of the total comes from the Russian placers, the output of which in a single recent year was approximately 153,000 ounces.

PLUMBAGO is black lead graphite, one of the forms in which carbon occurs in nature; it has an iron gray color and metallic luster, chiefly used in pencils, crucibles and portable furnaces; it is used to counteract friction in rubbing surfaces, and is used as a lubricant, dry, in powder form, or mixed with oil or grease, etc.

PHOSPHOR BRONZE is an alloy of copper, tin, lead and phosphorous; it is generally used for bearings requiring strength and durability; it has been adopted by some prominent railways, and is spoken of frequently as "standard metal."

PHOSPHOR TIN is an alloy used for making castings.

VARIOUS METALS, ALLOYS, ETC.

PHOSPHORUS is a solid, non-metallic, combustible substance not found by itself in nature. When pure it is semi-transparent and colorless, and is exceedingly inflammable. Probably no element of itself weakens cast iron as much as phosphorus when present in large quantities; most irons contain more than is beneficial. One part out of one hundred or less add to the quality of cast iron—above $1\frac{1}{2}$ parts to the 100 weakens it.

PLASTER is a composition of lime, sand, hair and water; hair is used to give it cohesion and prevent its breaking apart. Plaster made with a particular kind of calcined gypsum is called plaster of paris; it sets quickly but does not obtain much hardness.

SILVER is a metal of a white color; it is harder than gold and softer than copper. It is remarkable for its whiteness of color. Silver occurs in a great variety of ores all over the world. Native silver is of frequent occurrence; it is liable to tarnish, and is never used without alloy, as it is too soft.

SOLDER is an alloy of tin, bismuth and lead, extremely fusible; it is generally used for joining or binding together metallic joints or surfaces.

SPELTER is the name by which ingot zinc is called, and is seldom used except in commerce.

SULPHUR is an elementary substance which occurs in nature as a brittle crystalline solid; it melts at 238° Fah.; it occurs in great abundance in the neighborhood of extinct volcanoes. In the manufacture of iron sulphur is a great drawback, on account of making the metal difficult to work.

VARIOUS METALS, ALLOYS, ETC.

THALLIUM is a rare metal; it is malleable and very soft; it has a bluish white tinge.

TIN is a metal nearly resembling silver in whiteness and lightness and luster; it is highly malleable and takes a high polish; native tin occurs very rarely; it melts at 442° Fah.; its chief uses are for coating sheet iron, and for making alloys with copper and other metals.

TUNGSTEN is a rare metal, the ore of which is found in Cornwall, Eng.; it is used to improve the quality of steel. A certain per cent. of tungsten in steel makes it very hard.

ZINC is one of the chemical elements; its ore has long been known, and in combination with copper forms the well-known alloy called brass; it melts at 780° Fah.; its specific gravity is 7.19.

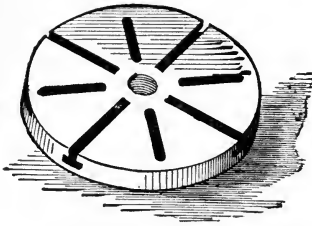

GRAVITY.

Our English word "gravity" is derived from a Latin word meaning "heavy;" hence its primary definition is "weight" or "heaviness."

We can not well say what gravity is, but may say what it does,—namely, that it is something which gives to every particle of matter a tendency toward every other particle. This influence is conveyed from one body to another without any perceptible interval of time. If the action of gravitation is not instantaneous, it moves more than fifty millions of times faster than light.

Gravity extends to all known bodies in the universe, from the smallest to the greatest; by it all bodies are drawn toward the center of the earth, not because there is any peculiar property or power in the center, but because, the earth being a sphere, the *aggregate* effect of the attractions exerted by all its parts upon any body exterior to it, is such as to direct the body toward the center.

This property discovers itself, not only in the motion of falling bodies, but in the *pressure* exerted by one portion of matter upon another which sustains it; and bodies descending freely under its influence, whatever be their figure, dimensions or texture, are all *equally accelerated* in right lines perpendicular to the plane of the horizon. The apparent *inequality* of the action of gravity upon different species of matter near the surface of the earth arises entirely from the resistance which they meet with in their passage through the air. When this resistance is removed (as in the exhausted receiver of an air-pump), no such inequality is perceived;

GRAVITY.

bodies of all kinds there descend with equal velocities; and a coin, a feather, and the smallest particle of matter, if let fall together, are observed to reach the bottom of the receiver exactly at the same instant.

The *weight* of a body is the force it exerts in consequence of its gravity, and is measured by its mechanical effects, such as bending a spring. We weigh a body by ascertaining the force required *to hold it back*, or to keep it from descending. Hence, weights are nothing more than *measures of the force of gravity* in different bodies.

It has been ascertained, by experiment, that a body falling freely from rest, will descend $16\frac{1}{2}$ feet in the first second of time, and will then have acquired a velocity, which being continued uniformly, will carry it through $32\frac{1}{2}$ feet in the next second. Therefore, if the first series of numbers be expressed in seconds, 1", 2", 3", &c., the velocities in feet will be $32\frac{1}{2}$, $64\frac{1}{2}$, $96\frac{1}{2}$, &c.; the spaces passed through as $16\frac{1}{2}$, $64\frac{1}{2}$, $144\frac{3}{4}$, &c., and the spaces for each second, $16\frac{1}{2}$, $48\frac{1}{4}$, $80\frac{5}{8}$, &c.

TABLE

Showing the Relation of Time, Space and Velocity.

Time in seconds of the body's fall.	Velocity acquired at the end of that time.	Squares.	Space fallen through in that time.	Space.	Whole space fallen through in the last second of the fall.
1	32.16	1	16.08	1	16.08
2	64.33	4	64.33	3	48.25
3	96.5'	9	144.75	5	80.41
4	128.66	16	257.33	7	112.58
5	160.83	25	402.08	9	144.75
6	193.	36	579.	11	176.91
7	225.17	49	788.08	13	209.08
8	257.33	64	1029.33	15	241.25
9	289.5	81	1302.75	17	273.42
10	321.66	100	1946.08	19	305.58

THE THREE LAWS OF MOTION.

Gravity operates under three great principles of motion, called the Laws of Motion.

First Law.—*A body continues in the state in which it is, whether of rest or motion, until compelled by some external force to change its state.*

Second Law.—*Motion, or change of motion, is proportioned to the force impressed, and is in the direction of that force.*

Third Law.—*When bodies act on each other, action and reaction are equal and in opposite directions.*

SPECIFIC GRAVITIES OF BODIES.

Every substance in nature has, under the same circumstances, a weight *specific* or peculiar to itself.

The Specific Gravity of a body is its weight compared with the weight of another body taken as a standard.

Water is the standard for all solids and liquids, and common air is the standard for gases.

The heaviest of all known substances is platinum, whose specific gravity, in its state of greatest condensation, is 22, water 1; and the lightest of all weighable bodies is hydrogen gas, whose specific gravity is $\frac{1}{1000}$, common air being 1, but air is 818 times lighter than water. Hence by calculation it will be found that platinum is about 247,000 times as heavy as hydrogen, and a wide range is thus allowed to the various bodies which lie between these extremes.

SPECIFIC GRAVITIES OF BODIES.

In taking the specific gravity of solids, advantage is taken of the important fact that when a solid is wholly immersed in water, it displaces a bulk of that liquid exactly equal to its own, and the solid appears to lose its weight; that is, it is supported by the surrounding water with a force exactly equal to the weight of the water displaced; hence, the difference of its weight in water from that of its weight in air must be the weight of an equal bulk of water.

These paragraphs relating to gravity, or the weight of bodies, are inserted after the subject of *Materials* because, in all practical mechanics, every particle of matter used or handled by the workman is instantly and constantly affected by this mysterious force, and it must be intelligently reckoned with to arrive at proper results.

HISTORICAL NOTE.—One of the most valuable discoveries made by Archimedes, the famous scholar of Syracuse, in Sicily, relates to the weight of bodies immersed in water.

Hiero, king of Syracuse, had given a lump of gold to be made into a crown, and when it came back he suspected that the workmen had kept back some of the gold, and had made up the weight by substituting silver; but he had no means of proving this, because they had made it weigh as much as the gold which had been sent.

Archimedes, puzzling over this problem, went to his bath. As he stepped in he saw the water, which his body displaced, rise to a higher level in the bath, and to the astonishment of his servants he sprang out of the water, and ran home through the streets of Syracuse almost naked, crying, "*Eureka! Eureka!*" ("I have found it! I have found it!")

What had he found? He had discovered that any solid body put into a vessel of water displaces a quantity of water equal to its own bulk, and therefore that equal weights of two substances, one light and bulky, and the other heavy and small, will displace different quantities of water.

This discovery enabled him to solve his problem. He procured one lump of gold and another of silver, each weighing exactly the same as the crown. Of course, the lumps were not the same size, because silver is lighter than gold, and so it takes more of it to make up the same weight. He first put the gold into a basin of water, and marked on the side of the vessel the height to which the water rose.

Next, taking out the gold, he put in the silver, which, though it weighed the same, yet, being larger, made the water rise higher; and this height he also marked. Lastly, he took out the silver and put in the crown.

Now, if the crown had been pure gold, the water would have risen only up to the mark of the gold; but it rose higher, and stood between the gold and silver marks, showing that silver had been mixed with the gold, making the crown more bulky; and by calculating how much water was displaced, Archimedes could estimate how much silver had been added.

This was the first attempt to measure the *specific gravity* of different substances; that is, the weight of any particular substance compared to an equal bulk of some other substance taken as a standard.

TABLE OF SPECIFIC GRAVITIES.

Iron, (cast).....	7.207	Gold (22 carats).....	17.481
“ (wrought).....	7.688	“ (20 “).....	15.709
Steel (soft).....	7.780	Silver (pure, cast)....	10.474
“ (tempered).....	7.840	“ (hammered)....	10.511
Lead (cast).....	11.400	Mercury (60°).....	13.580
“ (sheet).....	11.407	Pewter.....	7.248
Brass (cast).....	8.384	Tin.....	7.293
“ (wire drawn)...	8.544	Zinc (cast).....	7.215
Copper (sheet).....	8.767	Platinum.....	21.500
“ (cast).....	8.607	Antimony.....	6.712
Gold (cast).....	19.238	Arsenic.....	5.763
“ (hammered)....	19.361	Bronze (gun metal)...	8.700

Stones and Earth.

Coal (Bituminous)....	1.256	Lime.....	2.720
“ (Anthracite)..	} 1.436 1.640	Granite.....	2.625
Charcoal.....		.441	Marble.....
Brick.....	1.900	Mica.....	2.800
Clay.....	1.930	Millstone.....	2.484
Common Soil.....	1.984	Nitre.....	1.900
Emery.....	4.000	Porcelain.....	2.385
Glass.....	3.248	Phosphorus.....	1.770
Ivory.....	1.822	Pumice Stone.....	.915
Grindstone.....	2.143	Salt.....	2.130
Diamond.....	3.521	Sand.....	1.800
Gypsum.....	2.168	Slate.....	2.672
		Sulphur.....	2.033

Woods.

Ash.....	.845	Cherry.....	.715
Beech.....	.852	Cork.....	.240
Birch.....	.720	Elm.....	.671

TABLES OF STRENGTH OF MATERIALS.

1.—METALS.

Materials.	Limits of tensile strength.	Materials.	Limits of tensile strength.
Steel, best tempered	134,000—153,000	Iron, ship plates, average.....	44,000
Steel, cast, maximum	142,000	“ cast.....	14,000
“ shear.....	118,000	“ cast, mean of	45,970
“ blister.....	104,000	“ American....	31,800
“ puddled....	67,200	Copper, wire.....	61,200
“ plates, length-wise.....	96,300	“ wrought....	34,000
“ plates, breadth-wise.....	73,700	“ cast, American	24,250
“ razor.....	150,000	Platinum, wire....	53,000
Iron, wire..	73,000—103,000	Silver, cast.....	40,000
“ best Swed. bar	72,000	Gold, cast.....	20,000
“ bar, mean by		Tin, cast block....	3,800
Barlow....	56,560	“ Banca.	2,122
“ bar, inferior..	30,000	Zinc.....	2,600
“ boiler plates,		Bismuth.....	2,900
average.....	51,000	Lead, wire.....	2,580
		“ cast.....	1,800

2.—OTHER MATERIALS.

Glass, plate.....	9,400	Mortar, of 20 years..	52
“ flint.....	4,200	Roman cement, to	
Hemp fibres, glued....	9,200	blue stone.....	77
Hemp fibres, twisted		Wood, box...14,000—24,000	
(ropes).....	6,400	“ oak ...10,000—25,000	
Manila rope.....	3,200	“ locust tree....	20,100
Marble, different species.....	9,000	“ elm.....	13,200
	5,200	“ ash.....	12,000
Stone, different species.....	1,000	“ fir.....	8,330
	350	“ cedar.....	4,880
Brick, well burned...	750		

STRENGTH OF MATERIALS.

This is a general expression for the measure of capacity of resistance, possessed by solid masses or pieces of various kinds, to any causes tending to produce in them a permanent and disabling change of form or positive fracture.

As a matter of calculation its principal object is to determine the proper size and form of pieces which have to bear given loads, or, on the other hand, to determine the loads which can be safely applied to pieces whose dimensions and arrangement are already given.

The materials used in construction are chiefly four kinds.

1. Timber.
2. Rock or natural stones.
3. Brick, concrete, etc. (artificial stones).
4. Metals, especially iron.

All these resist fracture in whatever way, but the capability of resistance in a given case varies with chiefly the following: 1, the nature of the material and its quality; 2, the shape and dimensions of the piece used; 3, the manner of support from other parts; 4, the lines and direction of the force tending to produce rupture.

In the tables of strength which precede, the piece experimented on is (unless otherwise specified) always one the transverse section of which presents an area of 1 square inch; and the limits of strength found, known by the loads required to secure fracture, are expressed in pounds weight avoirdupois.

Tensile strength means the resistance to a *direct pull*; for illustration, see page 34.

STRENGTH OF MATERIALS.

Materials of all kinds *owe their strength* to the action of these forces residing in and about the molecules of bodies (the molecular forces), but mainly to that one of these known as *cohesion*; certain modified results of cohesion, as toughness or tenacity, hardness, stiffness, and elasticity are also important elements and the strength is in the relation of the toughness and stiffness combined.

A piece of iron or timber may be subjected to strain or fracture in four ways: 1, it may be stretched, pulled or torn asunder, as a tie-rod or a steam boiler. This is called tensile strain or tension, and is a direct pull; resistance to this force is called *tensile strength*. 2, the iron or timber may be crushed in the direction of the length as in columns and truss beams. This is direct thrust, direct pressure or compression; and the resistance to it, *the crushing strength*. An example of this is found in the force tending to collapse the flues of a steam boiler. 3, it may be bent or broken across by a force perpendicular or oblique to its length, as in common beams and joists. This is transverse strain or flexion; resistance to it *the transverse strength*. 4, it may be twisted or wrenched off, in a direction about its axis, as in case of shafting. This is torsion; resistance to it *the torsional strength*. (See figures on page 34.)

Let it be noted, that any bending or breaking pressure is *a stress*; its effect on the piece *a strain*; briefly, then, the strength of a solid piece or body is the total resistance it can oppose to strain in that direction.

IMPORTANT PRINCIPLES RELATING TO STRENGTH OF MATERIALS.

A rod, rope or any body being pulled in the direction of its length, its cohesion can come into play only by reason of the opposite length being fixed; and the amount of cohesion excited is a reaction against the strain applied; up to the limit

STRENGTH OF MATERIALS.

of strength the amount of cohesion is always exactly equal to the acting strain; at every moment the strain and reaction are equal throughout the whole length of the piece acted upon.

Where weight does not (as it must in any hanging rope or piece) come in to modify the result the piece must, when the limit of strength is exceeded, always part or yield at its weakest portion; that the tensile strength can never exceed that of such weakest portion.

Two fibres of like character equally stretched must exhibit double the strength of one. Generalizing this result, we say that the tensile strength of beams, rods, ropes, wires, etc., is, for each material, proportional to the area of the cross-section of the piece used. This is, accordingly, also termed the absolute strength.

When allowance for modifying influences is made, the laws of tensile strength become safe guides in practice, though the behavior of different materials in yielding to tension may vary considerably.

Any material, under a considerable tensile strain, becomes slightly elongated, not returning when the strain is taken off. This result is expressed by saying that the body possesses *extensibility*. It is doubtful whether in all materials, or in most, a result of this kind can be often or indefinitely repeated. But over this, the body lengthens a little by every pull in consequence of its elasticity; and this effect is not permanent, at least its whole amount is not so; the piece shortens again, when the strain is removed, by quite or nearly the amount of this lengthening.

If the body possesses *ductility*, when the limit of its *extensibility and elasticity* is reached, the particles upon the

FATIGUE OF METALS.

surface at the weakest point begin to slip upon each other; the body is by this action both permanently and sensibly lengthened or drawn out, and as this extension does not, as in wire-drawing proper, take place under circumstances favorable to increase of toughness, the strength is with the first yielding impaired; while, if the load be not then diminished, the yielding portion must be drawn rapidly smaller until it parts completely. Thus, for ductile materials, the load beyond which permanent change must occur is *the limit of strength*.

In metallic bars or links, timbers, etc., a considerable proportion of the actual strength is gained by means of the firm hold of the fibres laterally one upon another; as is proved by the fact that, of two ropes of like material and containing in their sections a like number of fibres, in one of which the fibres are twisted and in the other glued together, the strength of the latter is greater by at least one-third.

FATIGUE OF METALS.

A matter of great practical interest is the weakening which materials undergo by repeated changes in their state of stress. It appears that in some if not all materials a limited amount of stress variation may be repeated time after time without apparent reduction in the strength of the piece; on the balance wheel of a watch for instance, tension and compression succeed each other for some 150 millions of times in a year, and the spring works for years without showing signs of deterioration. In such cases the stresses lie well within the elastic limits; on the other hand the toughest bar breaks after a small number of bendings to and fro when these pass the elastic limits.

MELTING POINTS OF SOLIDS.

The metals are solid at ordinary temperatures, with the exception of mercury, which is liquid down to -39° F. Hydrogen it is believed, is a metal in a gaseous form.

All the metals are liquid, at temperatures more or less elevated, and they probably turn into gas or vapor at very high temperatures. Their melting points range from 39 degrees below zero of Fahrenheit's scale (the melting or rather the freezing point of mercury), up to more than 3,000 degrees, beyond the limits of measurement by any known pyrometer. Certain metals, such as iron and platinum, become pasty and adhesive at temperatures much below their melting points. Two pieces of iron raised to a welding heat, are softened, and readily unite under the hammer; and pieces of platinum unite at a white heat.

MELTING POINTS OF SOLIDS.

VARIOUS SUBSTANCES.	Melting Points.
Sulphurous acid.....	-148° F.
Carbonic acid.....	-108
Bromine.....	9.5
Turpentine.....	14
Hyponitric acid.....	16
Ice.....	32
Nitro-glycerine.....	45
Tallow.....	92
Phosphorus.....	112
Acetic acid.....	113
Stearine.....	109 to 120
Margaric acid.....	131 to 140
Wax, rough.....	142
" bleached.....	154
Iodine.....	225
Sulphur.....	239

MELTING POINTS OF SOLIDS.—(Continued.)

METALS.	Melting Points.
Mercury.....	-39° F
Potassium.....	144
Sodium.....	208
Lithium.....	356
Tin.....	442
Bismuth.....	507
Lead.....	617
Zinc.....	680 to 773
Antimony.....	810 to 1150
Bronze.....	1692
Silver.....	1832 to 1873
Copper.....	1996
Gold, standard.....	2156
Cast Iron, white.....	1922 to 2012
" " gray.....	2012 to 2786
Steel.....	2372 to 2552
Wrought Iron.....	2732
Hammered Iron.....	2912
<hr/>	
SUNDRY ALLOYS OF TIN, LEAD, AND BISMUTH.	Melting Points.
3 Lead, 2 Tin, 5 Bismuth.....	199°
1 " 1 " 4 ".....	201
5 " 3 " 8 ".....	212
1 " 4 " 5 ".....	246
1 " 3.....	334
2 " 1 ".....	334
1 " 2 ".....	360 to 385
3 " 1 ".....	392
3 " 1 ".....	552

It must be understood that these tables exhibit only to a degree, of accuracy, the results of very many attempts to arrive at the difficult although approximate results.

USEFUL WEIGHTS AND MEASURES.

A *measure* is a standard unit, established by law or custom, by which quantity is measured or estimated.

Unit is a work which denotes a single thing—the least whole number. The unit of numbers is the figure one (1).

The foot rule is the *unit* or measure of *length* most used; the foot is divided into twelve inches and the inch is subdivided in half inches, quarter inches, eighths and sixteenths. It is plain that into whatever number of parts the inch is divided, we shall equally have the whole inch if we take the whole of the parts of it; if it were divided into ten equal parts, then ten of these parts would make an inch.

The *unit of surface* is represented by the square inch, etc.

These references to the different measures, or units, are made because they enter into calculations in connection with Tables to be found elsewhere.

CIRCULAR MEASURE.

60 seconds (")	make	1 minute,	′
60 minutes,		1 degree,	°
360 degrees,		1 circum.,	C.

The circumference of every circle, whatever, is supposed to be divided into 360 equal parts, called *degrees*.

A degree is $\frac{1}{360}$ of the circumference of any circle, small or large.

A *quadrant* is a fourth of a circumference, or an arc of 90 degrees.

A degree is divided into 60 parts, called minutes, expressed by sign (′), and each minute is divided into 60 seconds, expressed by (″), so that the circumference of any circle contains 21,600 minutes, or 1,296,000 seconds.

USEFUL WEIGHTS AND MEASURES.

ROMAN TABLE.

I.	denotes One.	XVII.	denotes Seventeen.
II.	Two.	XVIII.	Eighteen.
III.	Three.	XIX.	Nineteen.
IV.	Four.	XX.	Twenty.
V.	Five.	XXX.	Thirty.
VI.	Six.	XL.	Forty.
VII.	Seven.	L.	Fifty.
VIII.	Eight.	LX.	Sixty.
IX.	Nine.	LXX.	Seventy.
X.	Ten.	LXXX.	Eighty.
XI.	Eleven.	XC.	Ninety.
XII.	Twelve.	C.	One hundred.
XIII.	Thirteen.	D.	Five hundred.
XIV.	Fourteen.	M.	One thousand.
XV.	Fifteen.	\overline{X} .	Ten thousand.
XVI.	Sixteen.	\overline{M} .	One million.

A bar ($\overline{\quad}$) placed over a letter increases its value a thousand times. Thus, \overline{X} represents ten thousand ; \overline{M} , one million.

TIME.

60 seconds,	make	1 minute.
60 minutes,		1 hour.
24 hours,		1 day.

365 days 5 hrs. 48 min, 48 seconds = 1 year.

Every year divisible by 4 is a leap year, and contains 366 days—the other years 365 days.

TROY WEIGHT.

24 grains (gr.),	make	1 pennyweight, pwt.
20 pennyweights,		1 ounce, oz.
12 ounces,		1 pound, lb.

A *carat*, for gold-weight, is 4 grains; for diamond-weight, is 3.2 grains.

USEFUL WEIGHTS AND MEASURES.

LONG MEASURE—MEASURES OF LENGTH.

12 inches,	=	1 foot.
3 feet,	=	1 yard.
5½ yards,	=	1 rod.
40 rods,	=	1 furlong.
8 furlongs,	=	1 common mile.
3 miles,	=	1 league.

The *mile* (5,280 feet) of the above table is the legal mile of the United States and England, and is called the statute mile.

Additional measures of length in occasional use: 3 inches = 1 palm; 4 inches = 1 hand; 6 inches = 1 span; 2½ feet = 1 military pace; 3 feet = common pace; $\frac{1}{48}$ of an inch = a hair's breadth.

SQUARE MEASURE—MEASURES OF SURFACE.

144 square inches,	=	1 square foot.
9 square feet,	=	1 square yard.
30¼ square yards,	=	1 square rod or perch.
160 square rods or perches,	=	1 acre.
640 acres,	=	1 square mile.

An *acre* equals 4,840 square yards or a square whose side is $208\frac{7}{10}$ feet.

Surface or Square Measures are used in computing areas or surfaces, as of land, lumber, painting, paving, etc.

A *Surface* has two dimensions, length and breadth.

A *Square* is a plane figure, bounded by four equal sides, and having four right angles.

A *Circular inch* is a circle whose diameter is one inch = 0.7854. A Square inch = 1.2732 Circular inches.

NOTE.

The difference between one square foot and one foot square. One foot square means one foot long and one foot wide, but one square foot can be of any shape, providing the area equals one square foot or one hundred and forty-four square inches,

 USEFUL WEIGHTS AND MEASURES.

AVOIRDUPOIS WEIGHT.

16 drams, or $437\frac{1}{2}$ grains,	=	1 ounce.
16 ounces, or 7,000 grains,	=	1 pound.
25 pounds,	=	1 quarter.
4 quarters, or 100 lbs.,	=	1 hundred-weight.
20 hundred-weight,	=	1 net ton.
2240 hundred-weight,	=	1 long ton.

In the United Kingdom 28 lbs. = 1 quarter.

4 quarters = 1 hundred-weight = 112 lbs.

1 stone = 14 lbs. 1 quintal = 100 lbs.

This table is used for nearly all articles estimated by weight, except gold, silver and jewels, for which the "Troy weight" table is used.

DRY MEASURE.

2 pints,	=	1 quart.
8 quarts,	=	1 peck.
4 pecks,	=	1 bushel.

This measure is used in measuring grain, fruit and other articles not liquid.

The standard U. S. bushel is the Winchester bushel = $18\frac{1}{2}$ inches in diameter \times 8 inches deep = $2,150\frac{4}{100}$ cubic inches.

IMPORTANT NOTE.

In a fairly long experience in mechanical pursuits in both Europe and America, the author has found the "data" printed on pages 65 to 72 of frequent service; hence he strongly recommends the study of the rules, measures and explanations given in these closing pages of the **PROGRESSIVE MACHINIST**.

USEFUL WEIGHTS AND MEASURES.

SOLID OR CUBIC MEASURE.

1728 cubic inches,	=	1 cubic foot.
27 cubic feet,	=	1 cubic yard.
128 cubic feet,	=	1 cord.

A pile of wood 4 feet wide, 4 feet high, and eight feet long, contains 1 cord; and a cord foot is 1 foot in length of such a pile.

This table is used in measuring bodies, or things having length, breadth and height or depth.

A *Solid* is a body, volume, or space, that has three dimensions, length, breadth and thickness. A *Cube* is a body bounded by six equal squares, called *Faces*. The sides of these squares are called the *Edges* of the cube. A *Cubic Inch* is a cube, each edge of which is 1 inch in length. A *Cubic Foot* is a cube, each of whose edges are 1 foot in length.

LIQUID MEASURE.

4 gills (gi.),	=	1 pint.
2 pints,	=	1 quart.
4 quarts,	=	1 gallon.
31½ gallons,	=	1 barrel.
42 gallons,	=	1 tierce.
63 gallons,	=	1 hogshead.

The *barrel* and *hogshead* are not fixed measures, but vary when used for commercial purposes. The capacity of these is found by actual measurement.

The U. S. gallon = 231 cubic inches.

British Imperial gallon = $277\frac{278}{1000}$ inches.

7½ gallons (U. S.) nearly = 1 cubic foot.

USEFUL WEIGHTS AND MEASURES.

TABLE OF ALIQUOT PARTS.

Of a \$.		Of a Ton.		Of a cwt.		Of an Acre.		Of a Month.	
cts.	\$	cwt.	ton.	lb.	cwt.	rd.	A.	d.	m.
50	= $\frac{1}{2}$	10	= $\frac{1}{2}$	50	= $\frac{1}{2}$	80	= $\frac{1}{2}$	15	= $\frac{1}{2}$
33 $\frac{1}{3}$	= $\frac{1}{3}$	5	= $\frac{1}{4}$	25	= $\frac{1}{4}$	40	= $\frac{1}{4}$	10	= $\frac{1}{3}$
25	= $\frac{1}{4}$	4	= $\frac{1}{5}$	20	= $\frac{1}{5}$	32	= $\frac{1}{5}$	7 $\frac{1}{2}$	= $\frac{1}{4}$
16 $\frac{2}{3}$	= $\frac{1}{6}$	2 $\frac{1}{2}$	= $\frac{1}{8}$	12 $\frac{1}{2}$	= $\frac{1}{8}$	20	= $\frac{1}{8}$	6	= $\frac{1}{5}$
12 $\frac{1}{2}$	= $\frac{1}{8}$	2	= $\frac{1}{10}$	10	= $\frac{1}{10}$	16	= $\frac{1}{10}$	5	= $\frac{1}{8}$
10	= $\frac{1}{10}$	1	= $\frac{1}{20}$	5	= $\frac{1}{20}$	8	= $\frac{1}{20}$	3	= $\frac{1}{10}$

An aliquot part of a number is an exact divisor of it; thus, 2, 4 and 8 are exact divisors of 16.

TRAVELLERS' NAUTICAL MEASURES.

TABLE.

60 Geographic. or 69.16 Statute Miles	} = 1 Degree	{ of Latitude on a Meridian, or of Longitude on the Equator.
360 Degrees		
1.15 $\frac{1}{2}$ Common Miles	= the Circumference of the Earth.	
3 Geographic Miles	= 1 Geo. Mi. Used to meas. distances at sea.	
	= 1 Nautical League.	

Miles and Knots.—A statute mile is 5,280 feet long. It is our standard of "long" measure adopted from the English, who in turn adopted it from the Romans. A Roman military pace, by which distances were measured, was the length of the step taken by the Roman soldiers. A thousand of these paces were called in Latin a mile.

The English mile is therefore a purely arbitrary measure, enacted into a legal measure by a statute passed during the reign of Queen Elizabeth: it has no connection with any scale in nature. A nautical mile, on the other hand, is equal in length to one-sixtieth part of the length of a degree of a great circle of the earth.

But the circumference of the earth is nowhere a true circle; its radius or curvature is variable; hence the nautical mile, as a matter of fact, depends for its length upon the shape as well as the size of the globe sailed over; and hence, strictly speaking, the length of the nautical mile should vary with the latitude, from 6,046 feet at the equator to 6,169 feet at the pole. Such extreme accuracy is not necessary in navigating and cannot be well attained without undue labor.

The British Admiralty therefore have adopted 6,080 feet as the length of a nautical mile, which corresponds with the length of one-sixtieth of a degree—of one minute of arc—of a great circle in latitude 48°.

USEFUL WEIGHTS AND MEASURES.

TABLE.

Showing relative value of French and English measures of length.

FRENCH.	=	ENGLISH.
Milimetre,	=	0.03937 inches.
Centimetre,	=	0.39371 “
Decimetre,	=	3.93710 “
Metre,	=	39.37100 “

In the French system of weights and measures, which has been legalized by special act of the U. S. Congress, the *metre*, *litre*, *gramme*, etc., are increased or decreased by the following words prefixed to them:

Milli	expresses	the	1,000th	part.
Centi	“	“	100th	“
Deci	“	“	10th	“
Deca	“		10 times	the value.
Hecto	“	100	“	“
Kilo	“	1,000	“	“
Myria	“	10,000	“	“

APOTHECARIES WEIGHTS.

SOLID MEASURE.

20 grains (gr.),	=	1 scruple (sc.).
3 scruples,	=	1 dram (dr.),
8 drams,	=	1 ounce (oz.).
12 ounces,	=	1 pound (lb.).

FLUID MEASURE.

60 minims or drops,	=	1 fluid dram.
8 fluid drams,	=	1 fluid ounce.
16 fluid ounces,	=	1 pint.
8 pints,	=	1 gallon.

USEFUL WEIGHTS AND MEASURES.

MONEY.

STERLING OR ENGLISH MONEY.

TABLE.

4 farthings (qr. or far.) make	1 penny,	d.
12 pence,	1 shilling,	s.
20 shillings,	1 pound or sovereign,	£.
10 florins (fl.),	1 pound,	£.

FRENCH MONEY.

TABLE.

10 centimes	=	1 decime.
10 decimes	=	1 franc.

The unit of French money is the franc, the value of which in U. S. money is 19.3 cents, or about $1/5$ of a dollar.

UNITED STATES MONEY.

TABLE.

10 mills are	1 cent,	ct.
10 cents are	1 dime,	d.
10 dimes, or 100 cents are	1 dollar,	dol. or \$.
10 dollars are	1 eagle,	E.

The *dollar* is the unit; hence dollars are written with the *sign* \$ prefixed to them and *the decimal point* placed after them.

Cents occupy hundredths place on the right of the decimal point and occupy two places, hence if the number to be expressed is less than 10 a cipher must be prefixed to the figure denoting them; one dollar and nine cents is written \$1.09.



DRAWING

FREE-HAND DRAWING.

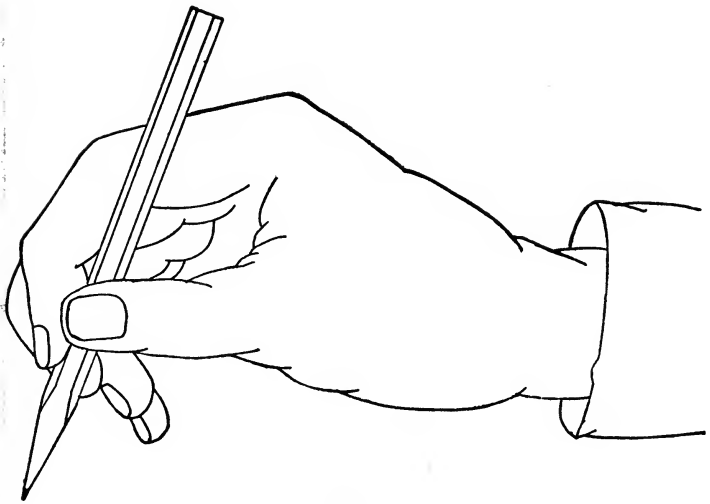
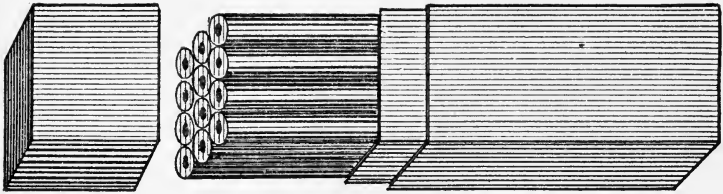

Fig. 8.



FREE-HAND DRAWING.

A free-hand drawing is executed with the unaided hand and eye, without guiding instruments or other artificial help. It is necessary to be known that all the drawing required in the office and shop cannot possibly be done by rule and compass, but that some portion must be drawn "free-hand," trusting to the eye alone.

Hence, it is important that the student should be able to sketch at sight from objects he may see, or to draw roughly with a piece of chalk or a pencil pieces of mechanism required to be represented.

Practice in free-hand should go along, little by little, as progress is made in mechanical drawing, in order to cultivate both branches equally. "A simple sketch will often," as it has been rather roughly said, "express more than yards of talk."

Even a slight sketch refreshes the memory, and in the case of a preparation of a complete set from a finished machine, with a view to the making of a mechanical drawing, the proper course to pursue is, in the first instance, to make a general sketch, letter the various parts for reference, and then prepare a series of de-



Fig. 11.

FREE-HAND DRAWING.

tailed sketches, similarly lettered, and diffuse with dimensions.

Every engineer, electrician and mechanic, whatever his specialty, feels to-day that the ability to sketch rapidly and clearly is among the absolute necessities for correct and prompt transactions of business, in giving and executing orders and doing business with persons outside his profession.

Mistakes and misunderstandings may be averted by means of rough sketches taken at the time and shown for confirmation; this also saves assistants from getting into trouble, especially if they pin the sketch to the order, for reference in case of any dispute arising.

Such are a few of the advantages of knowing how to sketch quickly and correctly.

In "free-hand" any sort of pencil is better than none, but there is a considerable advantage in having a good serviceable article—a pencil not too soft nor too hard, and one which will retain its point for some little time.

Fig. 8 shows the approved position in which the pencil should be held while sketching. See note relating to holding and using the pencil.

NOTE.—The pencil should be held firmly between the thumb and first finger of the right hand; press the second finger against the pencil at the opposite side to the thumb pressure, so that the pencil is firmly held by the contact of the thumb and two fingers—the third and fourth fingers just coming into easy reach of the paper surface—the wrist or ball of the hand resting lightly on the surface of the work—the arm resting on the desk or drawing-board for steadiness.

The motion of the pencil is produced from the movement of the fingers and thumb, principally in the vertical strokes, and the horizontal strokes are produced by fingers and thumb, combined with a wrist or elbow motion; the oblique lines and curves are produced with a free movement, with nothing cramped or confined about the finger joints.

FREE-HAND DRAWING.

SKETCH-BOOKS, with paper bound in cloth covers, are utilized for bold, off-hand sketches by experienced draughtsmen, but a single sheet of paper, used on both sides, is not unworthy of service in an emergency—or even the blank side of a letter may be available. Sketching-blocks, or paper “pads,” 4 x 6, or more, in size, and containing 48 sheets, are sold by stationers, and are found to be most convenient to have in hand and for practical use. Portfolio-envelopes, made of extra length paper (manila) are useful in filing away sketches and drawings. The size 10½ x 15 are used for United States Patent Office drawings.

BLACKBOARD DRAWING.—The use of a blackboard comes under the head of free-hand drawing, as the work on it is mostly done by hand, without aid from instruments; a few “tools,” however, are useful—such as, 1, large wooden blackboard compasses holding a crayon, which are made and sold by the trade in size twelve inches to thirty inches in length; 2, a straight-edge; and 3, some crayons. With the compasses circles and part of the circle can be made, and with the straight-edge the larger lines can be drawn.

Again, the board should be entirely free from grease; cloths, sponges or chamois skin rubbers may be used to erase or change the chalk marks; vertical lines should be drawn

NOTE.—In making a drawing of an object from the model it is well to observe the following order: Look the model over carefully and determine the number of views necessary to illustrate it fully, drawing the same, *free-hand*, in their proper relation to each other, on sketching paper. Look the sketch over carefully to see that nothing has been omitted, and put on dimension lines, after which scale the model carefully and put on dimensions. Do not put in the dimensions at the same time the dimension lines are drawn; have all the dimension lines in place before attempting to insert dimensions.”

Follow the same order in making the drawing with instruments as was used in making the sketch; that is, draw the views in their proper relation to each other, put in dimension lines, then dimensions, and lastly notes and title. If section drawing is made, do not draw section lines in pencil.—**AMERICAN MACHINIST.**

FREE-HAND DRAWING.

from above downward; the draughtsman should stand with his right shoulder opposite the vertical line to be drawn, and the weight of the hand and the arm should be allowed to fall naturally; very rapid drawing upon the board should not be encouraged, as it is likely not to be accurate enough. Chalk lines have this advantage—they are easily altered or rubbed out when not needed any longer.

Many a man can chalk out on a blackboard, or on a piece of sheet-iron, or on the floor, just what he wants to show, and make his meaning very plain; many things are wanted at once of which it would be needless to make a paper drawing, and where a pencil or chalk outline, with dimensions, will answer every purpose; hence, in every workshop, and many other places, a blackboard is more than useful, and it has been said that no draughting office is complete without one.

Practice in this should alternate with sketching in the sketch-book and with geometrical drawing—to be hereafter described—as drawing on the blackboard is indeed the most perfect illustration of the term free-hand drawing. A learner should practice a short time on the board, at least once a week; large sizes are the most profitable for the representations to be made; when drawing in different directions the hand should be turned, not the paper or board; never allow the hand to obstruct the sight, hence the hand and fingers should be held in a position of freedom—with fingers not nearer than $1\frac{1}{2}$ or 2 inches from the board.

Short lines should be drawn with the fingers alone, those somewhat longer with the hand, using the wrist-joint; the still longer lines draw with the forearm, using the elbow-joint; those longer yet, which will be usually on the blackboard, draw with the whole arm, using the shoulder-joint.

Draw lines always with a uniform motion, slow enough for the eye to follow.

DRAWING MATERIALS AND INSTRUMENTS.

Drawing tools or instruments are contrived solely for mechanical drawing; aside from this use they are perfectly worthless, hence the quality of these special utensils is a matter of the first consideration to the earnest student.

There are several degrees of excellence to be found in the make-up of drawing instruments and materials; it may be remarked with truth that "any kind are good enough, and the best none too good," i. e., a learner in this delightful art should not stop at the lack of goodness or the low grade existing in his "tools," but rather do the best work possible with the means at hand.

However, in order that acceptable work may be accomplished, fairly good instruments should be procured. The advice of some one experienced in draughting tools should be sought before purchasing, so important is the matter in results.

A drawing board, a sheet of paper and a pencil, and this first scrap of paper, it may be noted, *has two sides, which can be used in early practice*—is the "simplest outfit" possible; to this small beginning may be added, soon afterwards, a cheap pair of compasses, a T-square and a couple of triangles; a vast range of work can be executed with these few tools.

Nothing more will be positively needed to do fine work except, perhaps, one or two pairs of better compasses and a few sweeps or means of drawing irregular curves; all these had best be purchased separately; for in buying a "box of instru-

DRAWING MATERIALS.

ments," it may contain some articles which are not desired, or that are of a wrong size, or even duplicates of those already possessed.

An outfit recommended by the author of "Reed's Hand Book" is as follows:

Large compasses with movable leg.

A pair of dividers.

Bow pencil.

Bow pen.

Pencil leg for large compasses.

Pen leg for large compasses.

Drawing pen.

Louis Rouillion, B. S., Instructor of Drawing in Pratt Institute, Brooklyn, N. Y., recommends the following drawing outfit:

Compasses, $5\frac{1}{2}$ inches, with needle point; pen, pencil and lengthening bar.

Drawing pen, $4\frac{1}{2}$ inches.

T-square, 24-inch blade.

45-degree triangle, 9 inches.

30 and 60 degree triangle, 9 inches.

1 Scroll.

Dixon's V. H. pencil.

12-inch boxwood scale, flat, graduated to 1-16 inch the entire length.

Bottle of liquid India ink, four tacks, pencil and ink eraser.

20 sheets drawing paper, 11x15 inches, and a drawing-board about 16x23 inches will also be necessary; students can usually make these themselves for less money.

NOTE.—The purchasing of drawing tools is one of the most difficult points to settle that can present itself to a person about to buy a drawing outfit for the first time. Nothing can be so productive of distress to a person drawing as to have his tools getting out of order, joints one day too tight, next day too slack, points getting blunt or perhaps turning up altogether; if needle points, then the needles slip up, and drawing spoiled; in fact the purchaser can be annoyed in numberless different ways.—W. H. THORN.

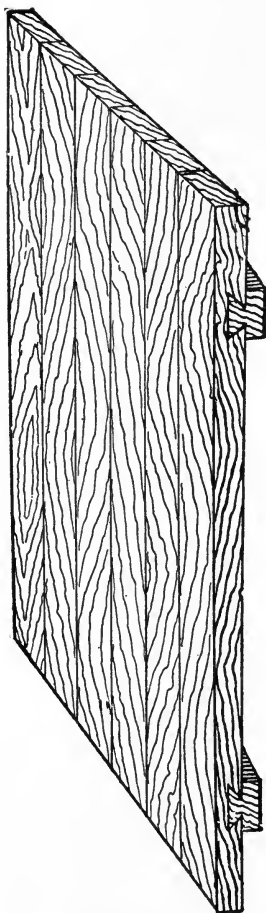

Fig. 12.

THE DRAWING BOARD.

The board should be made of well seasoned pine of a convenient size, say 23x16, which will take half a sheet of imperial paper, leaving $\frac{1}{2}$ -inch margin all round.

The working surface of the board—or its front side—should be perfectly smooth, but instead of being flat it should have a very slight camber, or rounding, breadthways, this latter feature in its construction being to prevent the possibility of a sheet of paper when stretched upon its surface having any vacuity beneath it.

The *four edges* of the board need not form an exact rectangle, as much valuable time is often wasted in the attempts to produce such a board; but it will answer every purpose of the draughtsman so long as the adjacent edges at the lower left-hand corner of the square are at right angles to each other.

An English authority recommends the use of two drawing-boards, 42 inches long and 30 inches wide, made of plain stuff, without cleets, $1\frac{1}{4}$ inches thick—seasoned—with edges perfectly straight and at right angles to each other. With two boards, one may be used for sketching and drawing details and the other for the finished drawing.

NOTE.—The board should be $\frac{3}{4}$ inches in thickness, and fitted at the back, at right angles to its longest side, with a couple of hardwood battens, about 2 inches wide and $\frac{3}{4}$ inch thick; the use of these battens being to keep the board from casting or winding and to allow of its expansion or contraction through changes of temperature. This latter purpose, however, is only effected by attaching the battens to the back of the board in the following manner: . . . At the middle of the length of each batten—which should be one inch less than the width of the board—a stout, well-fitted wood screw is firmly inserted into it, and made to penetrate the board for about $\frac{1}{2}$ inch, the head of the screw being made flush with the surface of the batten; on either side of the central screw, two others, about $3\frac{1}{2}$ inches apart, are passed through oblong holes in the battens, and screwed into the body of the board until their heads are flush with the central one; fitted in this way the board itself can expand or contract lengthwise or crosswise, while its surface is prevented from warping or bending.

THE TEE-SQUARE.

This is an instrument in the form of a letter T, as shown in the figure,—see below—the two parts are known as *stock*

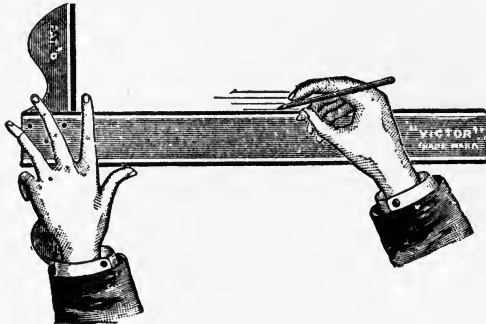

Fig. 13.

and *blade*; the horizontal part of the latter (T) is the stock, and the vertical part the blade—hence the name, T-square.

To form the square, the two parts are joined together in such a way as to make them exactly at right angles to each



Fig. 14.

NOTE.—DRAWING-PINS, OR THUMB-TACKS.—For mechanical drawing the invariable practice is to secure the paper on which the drawing is to be made to the drawing board by pinning it; this is effected by various kinds of *drawing pins*. The only kind of pins a mechanical drawer should use, should have a head as thin as possible, without cutting at its edges, slightly concave on the under side next the paper, and only so much convex on its upper side as will give it sufficient thickness to enable the pin to be secured to it; better use four or more small pins along the edge of a sheet of paper, than use one clumsy, badly made pin at each end—projecting or thick heads; milled edges damage the squares.

THE TEE-SQUARE.

other; the stock, which is applied to the working edge of the drawing board, being about one-third the length of the blade, and about three times its thickness.

TRIANGLES OR SET-SQUARES.

Set-squares are invariably used in connection with the tee-square as shown in fig. 14. The illustrations below show several patterns of the device; by these, vertical lines, triangles, squares and hexagonal, octagonal and twelve-sided figures, diagonal section lines, etc., can be easily drawn. For ordinary purposes, a triangle or set-square with angles of 45°



Fig. 15.

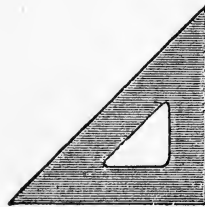

Fig. 16.

may be 4 inches long and the other 8 inches in length, but a six-inch set-square having angles 90° , 45° and 45° and an eight-inch one having angles of 90° , 60° and 30° , will be found sufficient for all purposes; there are other triangles used specially for making letters.

In practice the triangles or set-squares are slid along the edge of the blade, and need not be any thicker than it.



Fig. 17,



Fig. 18.

DIVIDERS AND COMPASSES.

These two instruments, while they appear alike, have a separate use; the dividers are used to space off distances and dimensions; especially are they necessary in reading drawings made to scale. *Compasses* are used for describing circles, curves, etc., and *dividers* are used for marking out spaces.

Two forms of the dividers are shown in figs. 19 and 20; the simplest, plainest form is shown in fig. 19; these are used for rough spacings; fig. 20 represents a pair of dividers fitted with an adjustable screw controlled by a steel spring in one leg; by this a very exact measurement can be made. Fig. 20 is intended to exhibit what is called "a hair-spring divider."

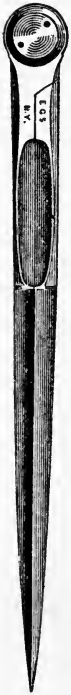

Fig. 19.



Fig. 20.

COMPASSES.

Compasses consist of two pointed legs; they are instruments for describing circles or for—sometimes—measuring figures, in absence of dividers. Fig. 21 represents compasses fitted as dividers.

Compasses should have jointed legs, which will allow the points to be placed at right angles to the paper, whatever

COMPASSES.

the size of the circle to be drawn. Compasses should not be used for circles which are too large to allow the



Fig. 21.

Fig.
22.Fig.
23.Fig.
24.Fig.
25.

points to be thus placed; a lengthening bar is generally provided, which greatly increases the diameters of circles

COMPASSES.

which may be drawn by this attachment, is shown in fig. 22.

One leg of the compasses is usually provided with a socket to which are fitted three points; a divider point, fig. 25; a pencil point, fig. 23, and a point, fig. 24, carrying a special pen for the inking of circles. Each of these points is generally provided with a joint, so that it may be placed at right angles to the paper.

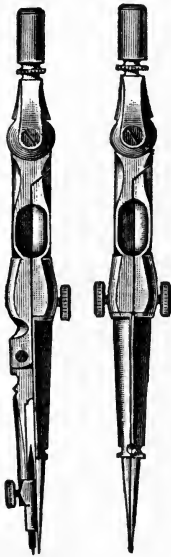

Fig. 26. Fig. 27.

The other leg should be jointed; it is often provided with a socket which receives two points, one a divider point, and the other carrying a needle point. Such an instrument may be used as dividers for spacing, or as compasses for penciling or inking circles.

The joint at the head of the compasses, see fig. 21, is the most important feature. It should hold the legs firmly in any position, so that in going over a circle several times only one line will result. It should allow the legs to move smoothly and evenly, and should be capable of adjustment.

As shown in fig. 21 one leg has a hinge or joint, and a needle point, which can be regulated by a thumb screw; the

NOTE.—Compasses specially used for putting in fine circles and dimensions are called “bows.” When a pen point it is a “bow pen,” with a pencil point a “bow pencil,” and if with needle point a “bow dividers.” Fig. 26 is a “bow dividers”; this fitted with screw for fine adjustment in one leg, fig. 27, is called a “hair-spring bow dividers”; for small details, bows with steel spring legs without any joint are used; these are called “steel-spring bows.”

DRAWING SCALES.

Scales are proportioned rules or mathematical instruments of wood, metal, etc., on which are marked lines and figures for the purpose of measuring sizes and distances. It

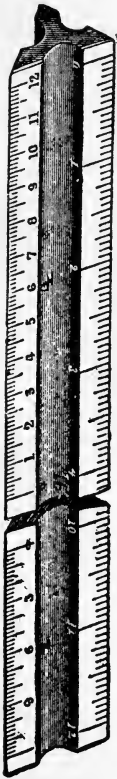

Fig. 28.

is usual to make scales in the proportion of *parts of an inch* equalling a foot; the most generally adopted scale for machine drawing is one and a half inches, equalling one foot; that is, twelve-eighths of an inch (each eighth of an inch representing one inch); there is no fixed rule in the choice of a scale, as they are varied according to the coarseness or fineness of the parts of the machine to be drawn and the space or surface of paper to be utilized.

When objects are of moderate proportions they may be represented full size; but when large, the drawings must be smaller. Standard scales for mechanical drawings are $\frac{1}{2}$, $\frac{1}{4}$, $\frac{1}{8}$, and $\frac{1}{16}$ full size. These scales are often written $6''=1 \text{ ft.}$; $3''=1 \text{ ft.}$; $1\frac{1}{2}''=1 \text{ ft.}$ and $\frac{3}{4}''=1 \text{ ft.}$

Instead of selecting one of the scales named or one found upon the ordinary scales used by draughtsmen, drawings may be made to any scale whatever. Thus, if any object is to be represented in a certain space, a scale should be constructed which will cause the whole of the object to be shown.

DRAWING TO SCALE.—The meaning of this is, that the drawing when done bears a definite proportion to the full size of the particular part, or in other words, is precisely the same as it would appear if viewed through a diminishing glass.

THE TWO-FOOT RULE shown in fig. 29 is the most useful instrument for the comparison of linear dimensions—it can be used as a scale of one-twelfth, or 1 inch equal to a foot, 12 inches = 12 feet, it being divided into portions or

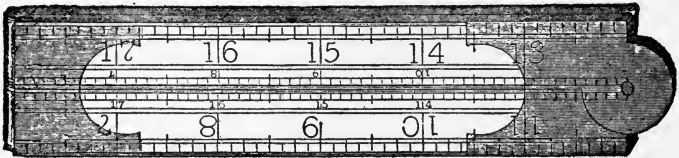

Fig. 29.

spaces, each of which is subdivided into halves, quarters, eighths and sixteenths; frequently in the latter class of 2 ft. rules there are graduations of scales, and it is then also called a draughting scale. Fig. 30 represents a flat scale, graded so that one inch represents a foot— $\frac{1}{12}$ th size—etc., as shown. Fig. 28 represents a triangular scale (broken). The

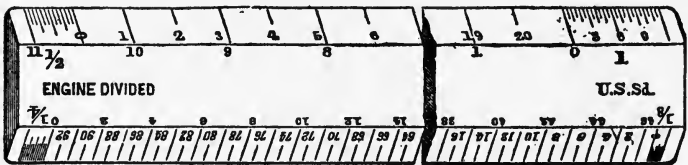

Fig. 30.

triangular scale should read on its different edges as follows: Three inches and $1\frac{1}{2}$ " to one foot, 1" and $\frac{1}{2}$ " to one foot, $\frac{3}{4}$ " and $\frac{3}{8}$ " to one foot, $\frac{1}{4}$ " and $\frac{1}{8}$ " to one foot, $\frac{1}{16}$ " and $\frac{3}{32}$ " to one foot, and one edge read sixteenths the whole 12" of its length. Fig. 30 shows such a scale broken. An explanation of the 1" and $\frac{1}{2}$ " side will suffice for all. Where it is used as a scale of 1" to one foot, each large space, as from 0 to 12 or 0 to 1, represents a foot, and is a foot at that scale. There being 12" in one foot, the twelve long divisions at the left represent inches; each inch is divided into two equal parts, so from 0 to one division at the left of 9 is $9\frac{1}{2}$ " and so on. The 1" and $\frac{1}{2}$ " scales being at opposite ends of the same edge, it

is obvious that one foot on the 1" scale is equal to two feet on the $\frac{1}{2}$ " scale, and conversely, one foot on $\frac{1}{2}$ " scale is equal to six inches on the 1" scale; and 1" being equal to one foot, the total feet in length of scale will be 12; at $\frac{1}{2}$ " to one foot the total feet will be 24.

In working to regular scales, such as $\frac{1}{2}$, $\frac{1}{8}$, or $\frac{1}{16}$ size, a good plan is to use a common rule, instead of a graduated scale. There is nothing more convenient for a mechanical draughtsman than to be able to readily resolve dimensions into various scales, and the use of a common rule for fractional scales trains the mind, so that computations come naturally, and after a time almost without effort.

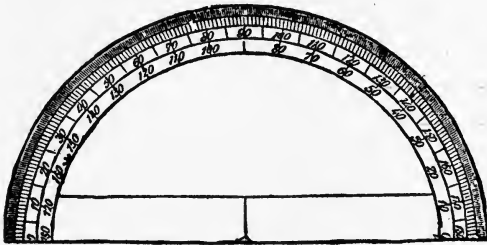
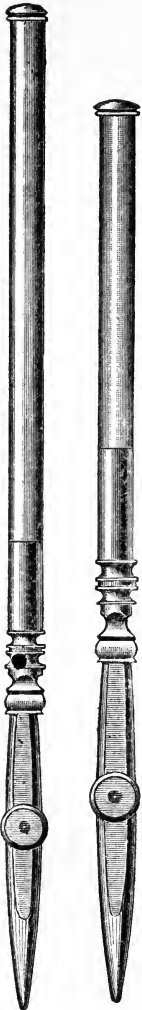

Fig. 31.

THE PROTRACTOR.

The protractor shown in fig. 31 is an instrument for laying down and measuring angles on paper; it is used in connecting with a scale to define the inclination of one line to another.

Protractors have the degrees of a half circle marked upon them; as the whole circle contains 360 degrees, half of it will contain 180, one quarter 90, etc. Hence, protractors showing 180° exhibit all that is needed. To protract means to extend, so this instrument is also useful in "extending" the lines of inclination at the circle.



DRAWING-PENS.

A special pen called a drawing-pen, and also special ink, are required to ink a drawing; figs. 32 and 33 represent two sizes of drawing-pens—one being best adapted for fine work, and the other for coarse or heavy line work. The points, as will be observed in the illustration, are made of two steel blades which open and close as required for thickness of lines by a regulating screw.

Fig. 32. Fig. 33.

In practice the flat side of the drawing-pen is laid against the tee-square or ruler; the taper of the blade of the pen is sufficient to throw the point enough away from the edge to prevent blotting; the pen is drawn from left to right and from the bottom to the top of the board.

This is shown in fig. 34, intended to represent "short work" with the drawing-pen. The wrist is shown resting upon the blade of the square.

In a similar figure, 35, the position of the hand holding the pen indicates the best relative posture for inking long lines. In one of these illustrations the work is executed principally

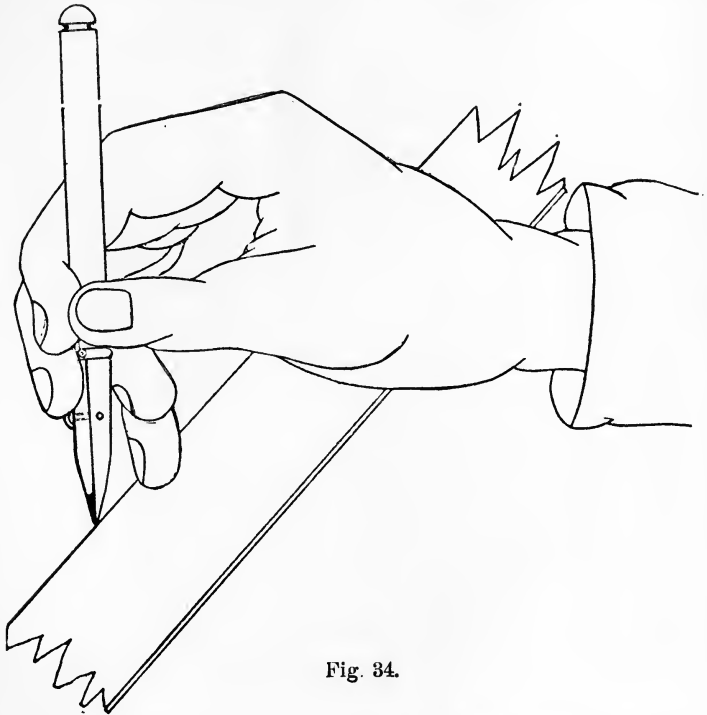

Fig. 34.

by the wrist—in the other by the arm and fingers working together.

The pen should be held with even pressure against the straight edge or curve. If the pressure varies, the blades will spring and the width of the line will change. The blades should be of such length that both will bear equally upon the paper when the pen is inclined slightly, so as to bring the inner blade near the straight edge; the angle of the pen should not be changed while drawing any line.

NEEDLE POINTS.—In marking off distances, centers, etc., a fine needle point is required; the hole should not be punctured through the paper, merely a prick point, so that it will leave an impression, which will not be obliterated by the use of rubber; drawing-pens are often equipped with such a needle point in the end of the handle, that is visible only when the pen is unscrewed from the handle; but in the absence of one of this kind the point of the divider leg will be of use.

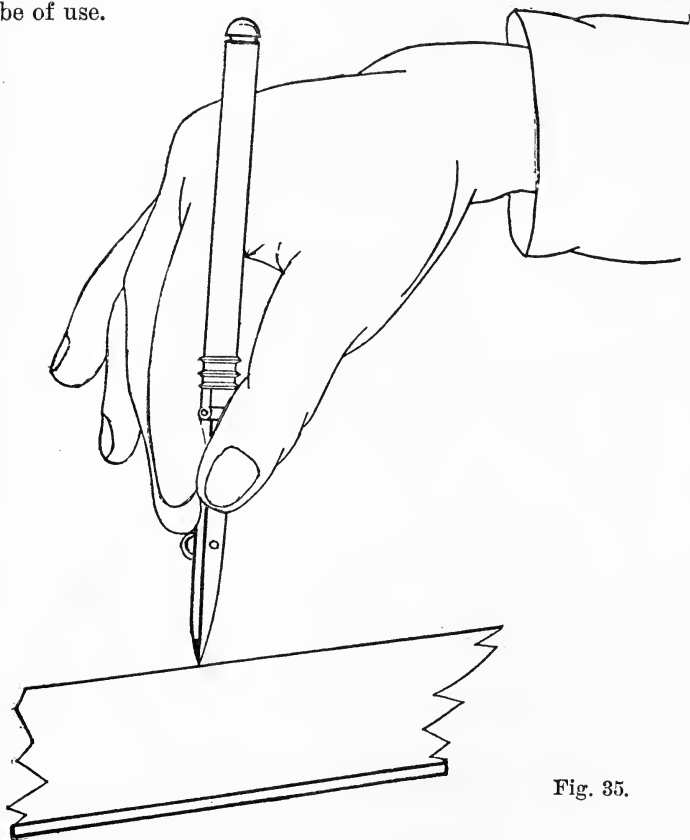

Fig. 35.

If the pen is not in use, even for a short time, the ink should be taken out, as it evaporates quickly and clogs the pen. For this purpose, pass the corner of a piece of chamois skin between the nibs of the pen.

PENCILLING.

With all necessary materials in hand, and in good order for the beginning of a drawing, the first thing to do is to pin the paper on the board quite square.

To do this effectively, lay the paper flat and put on the T-square with its head at the left side of the board; slide the square up nearly to the top, and arrange the paper level with the blade; with the right hand hold the paper still and move the square down a little; now, pin the top of the paper with thumb tacks.

Next, pressing the square lightly to the paper, slide it down to the bottom and pin that part of the paper to the board. The paper must not project outside or over the edges of the board, and the pins or tack-heads should be forced down flush with the paper, so as not to interfere with the free movement of the tee-square up and down the board as occasion may require.

The accuracy of the work depending upon their condition, it is first needful to see that the pencil and pencil compasses are properly sharpened. Reference is made to valuable directions contained on pages **119** to **123** under the heading of "Points."

All lines should be drawn with the pencil slightly inclined in the direction in which it is moved.

Any and all lines not needed in the finished drawing should be erased at one time after the final lines have been determined, for the surface of the paper is soiled very quickly when worked upon after erasures have been made.

The working lines and other lines that are to be removed should be erased when the drawing is ready to finish and before its outlines have been strengthened, in order that the final lines may be left in perfect condition.

NOTE.—To show where the lines meet or terminate it is needful that *all pencil lines* pass the actual ending place, making a distinct intersection. This does not apply to "inking in" the lines, but rather to prevent the over-drawing of the ink lines, because the edge of the rule and the pen itself obstruct or partly cover the view of the line, it is very liable to pass over or beyond the required point in *inking the lines, which must not occur.*

INKING.

When a drawing is completely finished in penciling, it should next be "inked in" for preservation. Something has been said on this subject, page 119, under another head to which these directions for the performance of the work apply.

Care should be used that the pen may be perfectly clean; the pen should be held nearly vertical, leaning just enough to prevent it from catching on the paper; the pen should be held between the thumb and first and second fingers, the knuckles being bent, so that it may be at right angles with the length of the hand. The ink should be rubbed up fresh whenever it is about to be used, for it is better to waste a little time in preparing ink slowly than to be at a continual trouble with pens, which will occur if the ink is ground too rapidly or on a rough surface. To test ink, a few lines can be drawn on the margin of a sheet, noting the shade, how the ink flows from the pen, and whether the lines are sharp. After the lines have dried, cross them with a wet brush; if they wash readily, the ink is too soft; if they resist the water for a time and then wash tardily, the ink is good.

Care must be exercised not to overload the pen with ink, and, like the pencil, the pen should always be moved from left to right and from the bottom to the top of the board. When inking both "nibs" of the pen point must rest evenly on the paper and the pen pressed only lightly against the T-square.

Never ink any portion of a drawing until the penciling is complete.

In inking long, fine lines it is well to go over each line twice, without moving the T-square, trying not to widen the

NOTE.—To produce finished drawings, it is necessary that no portion should be erased, otherwise the color applied will be unequal in tone; thus, when highly finished mechanical drawings are required, it is usual to draw an original and to copy it. Where sufficient time cannot be given to draw and copy, a very good way is to take the surface off the paper with fine sand-paper before commencing the drawing; if this be done, the color will flow equally over any erasure it may be necessary to make afterwards,

INKING IN DRAWINGS.

line on the second passage; also see that the pen contains ink enough to finish a line, as it is difficult to continue with the same width of line after re-filling.

When the inking is finished the whole drawing may be cleaned by rubbing it with bread, which is not greasy or so fresh as to stick to the paper. If the paper is much soiled it may be necessary to use an eraser. A soft pencil eraser should be used and great care taken that the ink lines are not lightened and broken by it.

To avoid the necessity of using an eraser upon a finished drawing, instruments and paper must be kept free from dust and dirt. The triangles and T-square should be cleaned often, by rubbing them vigorously upon rough, clean paper.

LETTERING DRAWINGS.

Lettering a drawing is a very important part of the work, the object aimed at being to identify any portion by reference letter or letters; thus in fig. 36 the line A C describes the line extending from A to C.



Fig. 36.

For easy reference, letters should not be crowded nor allowed to interfere with one another; they should be drawn neatly, avoiding all lines of the drawing. Plain letters and figures are always used on mechanical drawings, whether for title, scale, reference, etc.

NOTE.—Any information which cannot be expressed in the drawing is always expressed by lettering, and it is desirable to confine the lettering of drawings to one or two standard alphabets that are plain and distinct, and the principles of which are easily acquired. These conditions are fulfilled in the Gothic fonts shown.

LETTERING DRAWINGS.

A B C D E F G H I
J K L M N O P Q R
S T U V W X Y Z

a b c d e f g h i
j k l m n o p q r
s t u v w x y z

1 2 3 4 5 6 7 8 9 0

A B C D E F G H I
J K L M N O P Q R
S T U V W X Y Z

a b c d e f g h i
j k l m n o p q r
s t u v w x y z

1 2 3 4 5 6 7 8 9 0

LETTERING.

Neat, well-lettered drawings go far towards establishing a high standing for the aspiring draughtsman. All lettering should be done free-hand, first with the pencil, sharpened to a fine round point, and afterwards done in ink. For this purpose common writing pens are best to be used; fig. 37 represents the several numbers of the approved Gillott's pens adapted to this purpose.

Arrow-heads, figures and letters should be in black, and made with a writing pen. A pen with a ball point is preferable, giving an equal thickness of line, no matter in which direction the stroke is made.



Fig. 37.

Letters should not be less than one-eighth of an inch in height and pencilled carefully before inking.

Both letters and figures must be carefully made and of uniform proportion; it is well to "lay out" these by regular measurement before permanently inking them.

On page 97 are printed two forms of numerals and letters of the alphabet; it is recommended that these be used both for practice in lettering and for office work.



DIMENSIONING.

To "dimension" working drawings is to place measurements upon the parts represented, to enable the workman to proceed without measuring the drawing itself.

These dimensions should be placed so as not to interfere with nor crowd the lines of the drawing, nor yet interfere with one another.

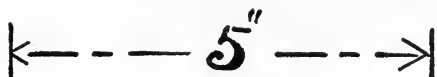
Arrow-heads are used at the extreme points of measurement, the figures are generally inserted midway between the arrows; a dot and dash line reaches from the figure to the arrow-heads, as shown below.



When the dimension is short these lines are omitted and the dimension is placed outside the drawing, thus  and connected by a curved line; at other times it is found needful to place arrow-heads outside the drawing and the measurement inside. .

When the dimension is long and narrow it is usual to carry the dimensions under the drawing by dotted and dash lines, as shown in last figure of example.

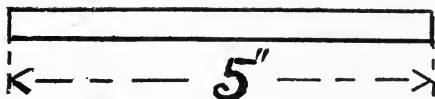

Fig. 38.

Arrow-heads and figures should be drawn free-hand with a common writing pen.

NOTE.—Usually dimensions are given in inches, up to 24 inches, as it is found less confusing; for instance, if written 1' 1" it may be mistaken for 11"; if written 13" no mistake could be made.

Again, 1' 0" may be mistaken for 10"; if written 12" it would not; in addition to being more distinct, it occupies less space on the drawing. In large measurements there is more room for the figures and, therefore, they can be spaced further apart—in feet and inches.

DIMENSIONING.

All figures should be made of a fairly large size. Vertical dimensions should read from the right hand, thus, as shown:

Measurements of importance, such as the diameter of a circle, the pitch or distance apart of rivets and bolts, etc., should be marked in figures on the drawing. When rough or unfinished work is mixed with machined or finished portions, it is usual to mark F or "fin." after the latter dimension.

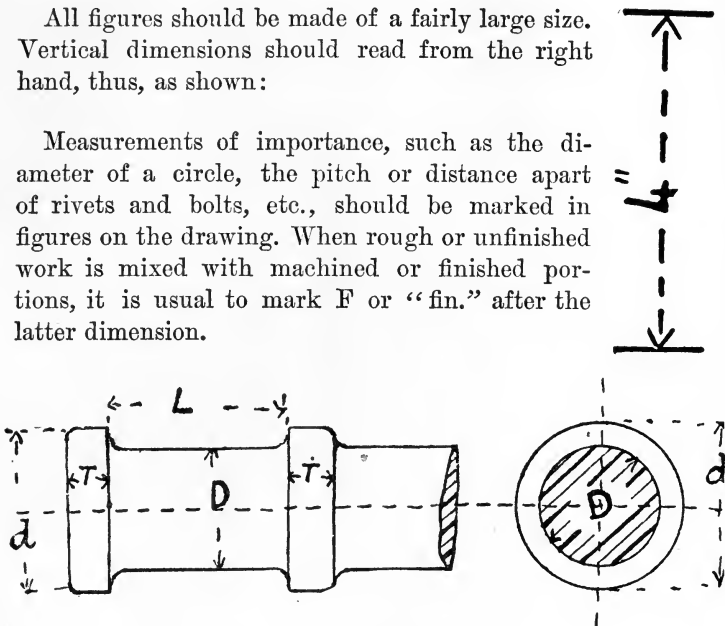

Fig. 39.

In practice, at times, instead of dimensions reference letters are used, thus:

D=diam. of shaft, $2\frac{1}{2}$ inches.

L=length of bearing, $3\frac{3}{4}$ inches.

T=thickness of collar, $\frac{7}{8}$ inch.

D=diam. of collar, $3\frac{1}{2}$ inches.

Generally it is preferable to give the diameters of turned and bored work on a section, instead of an end drawn separately; confusion is sometimes caused by a number of radial dimensions.

NOTE.—“ Now, one of the important matters in connection with dimensioning a drawing is the location of the figures. One rule, whose utility cannot be gainsaid, is that they should be so located that they can be altered or erased without damage to the lines of the drawing, as changes may be necessitated either by original errors in writing down the figures or by changes in the design being found desirable during the construction of the machine.”

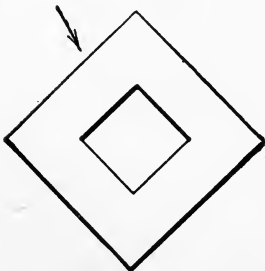
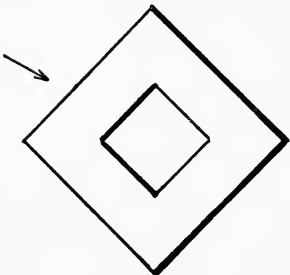
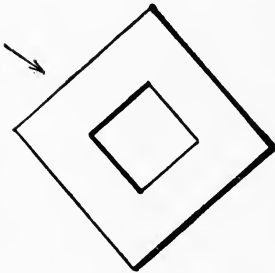
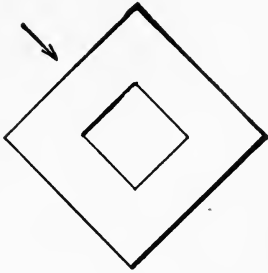

SHADING DRAWINGS.

To produce an effect, drawings are shaded; that is, shadow lines about twice the width of the regular line are drawn according to a recognized rule, which always represents the same peculiarity of form in the same way.

In working drawings light lines only are permitted; shade lines are wider than the working lines, and in reading scale measurements the extra thickness of line would make a difference.

Instead of representing the shadow as it is really cast by the object, the edges which cast the shadow are determined, and all the views are treated as if the light came from behind and from the left, downwards, at an angle of 45° to the horizontal line, as shown by the arrows in figs. 40 to 43.

The lower and right-hand outlines of projecting parts will cast shadows, and the student should make them of extra width.

Figs. 40-43.

SECTION LINING.

Cross-hatching has been defined in the "preliminary definitions" to drawing; this term, like the above, represents the practice of drawing diagonal lines to represent the interior of a piece, shown as a piece cut in half or when a piece is broken away. This is done to make more of the parts show, or to show more clearly the nature of the materials; hence section lining and cross-hatching tell the same thing, *i. e.*, the drawing of diagonal lines, usually at an angle of 45° to show clearly that the object is broken away and the interior designed to be represented. Figs. 44 to 51, inclusive, show the section lining and cross-hatching by which it is customary for experienced draughtsmen to represent the various materials entering into a construction.

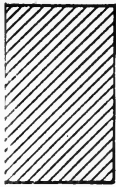

Cast iron.



Wrought iron.

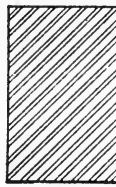

Steel.

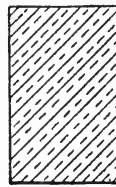

Composition



Vulcanite.

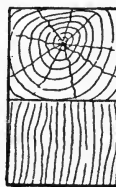

Wood.



Leather.

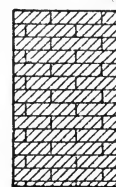

Brick.

Figs. 44-51.

Sections are necessary in nearly all machine drawings; they are usually taken horizontally or vertically, but they may be taken in any direction; the position of a section should be shown by a line upon the object; this line is called the cutting plane.

SECTION LINING.

Sectioning is done by drawing a series of parallel lines about $\frac{3}{32}$ inches apart. Lay the 45° triangle or the upper edge of the T-square and draw the topmost line of the sectioning. Then slide the triangle along the T-square for each successive line. The sectioning should be inked in without previous penciling and the lines should be finer than the lines of the general drawing. Various devices are in use for mechanically equalizing the distances in section lining, but the trained eye is the most practical method. When two abutting pieces are sectioned, the section-lining on one piece slants in an opposite direction to that on the other.

In practice, when an object to be sectioned is the same on both sides of its center line, only one side is sectioned while the other side is drawn in full.

In fig. below, is to be seen in the hub of the wheel, a fine sample of work very suitable for practice.

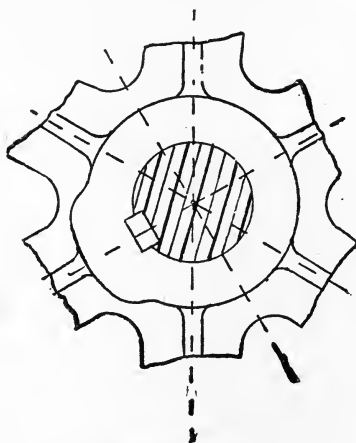
**Fig. 52.**

TO READ WORKING DRAWINGS.

To readily and correctly utilize a working drawing, is a matter of experience and practice. *A little showing* for the beginner is something for which he may be thankful.

In this work much is made of definitions; these are, first, to be carefully studied and committed to memory; second, the simplest examples given for exercise should be executed, and the principles they are designed to illustrate should be learned.

In studying a drawing, the object it is intended to represent should be made familiar as possible to the mind of the student, so that he may fill out in imagination the parts designedly left incomplete—as in a gear wheel where only two or three teeth are drawn in, that he may see, mentally, the whole.

The following is a description both of dimensioning and of reading drawing.

Here we have a piece of machinery represented by fig. 53 and the information we have is that it is to scale, three inches = one foot. Now, with scale and dividers, we can arrive at its actual dimensions.

NOTE.—One of the advantages resulting from a knowledge of practical draughting is, that it enables a mechanic to *read* a drawing when given him as a guide for his work. It is getting every day more general among draughtsmen to figure exactly and minutely every part of their drawings which are drawn to a scale. Even in full size drawings this system of figuring is not objectionable. It is a system which should be followed whenever a drawing is made "to work to," for it allows the workman to comprehend at a glance the size of his work and the pieces he has to get made. Figuring makes a drawing comprehensible even to those who cannot make drawings. Drawings are almost always made "finished size," that is, the dimensions are for the work when it is completed. Consequently all the figures written on the different parts indicate the exact size of the work when finished, without any regard to the size of the drawing itself, which may be made to any reduced and convenient scale.

TO READ WORKING DRAWINGS.

A working drawing should be made, primarily, as plain as possible by the draughtsman ; second, the workman should patiently and carefully study it, so that it is thoroughly understood, before the executing of the object delineated is begun. Figs. 53 and 54 may be considered "working drawings."

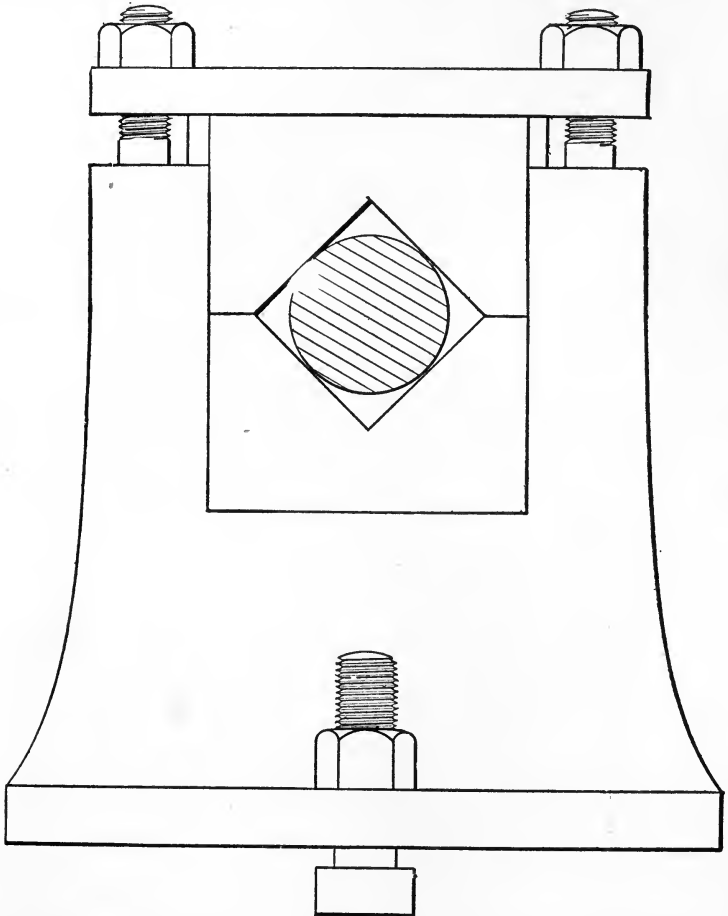

Scale 3 in. = 1 ft.

Fig. 53.

Front View.

NOTE —A working drawing, so called, is made in the office to a certain "scale" or proportion, *i. e.*, in the example three inches on the drawing equals one foot of the object represented, a steady rest.

TO READ WORKING DRAWINGS.

The machinist is required to do the work according to the scale marked on the drawing.

Measurements should be first taken *with the dividers from the drawing*, and then the dividers are applied to the scale, to which the drawing is made; this scale is always marked on the working drawing; if the dividers are set to the length

of the base of the example, they will measure, on an ordinary two-foot rule, three and three-fourths inches, *but, if applied to the three-inch scale they will read one foot, three inches*, the actual length of the part; the "reading" is from the scale; thus, in fig. 196, the drawing is "three inch scale." Now, 3 inches is one-fourth of a foot, hence $3\frac{3}{4} \times 4 = 1 \text{ ft. } 3 \text{ in.}$, the full size, and so on for all parts of the drawing.

Fig. 54 shows a *side view* of the "steady rest," already illustrated in front elevation, fig. 53; from the scale as before we get the sizes; the two views combined give length, breadth and thickness of the parts.

In some figures it is necessary to show end views, also section views, as in page 125, to enable all measurements to be read from the drawing.

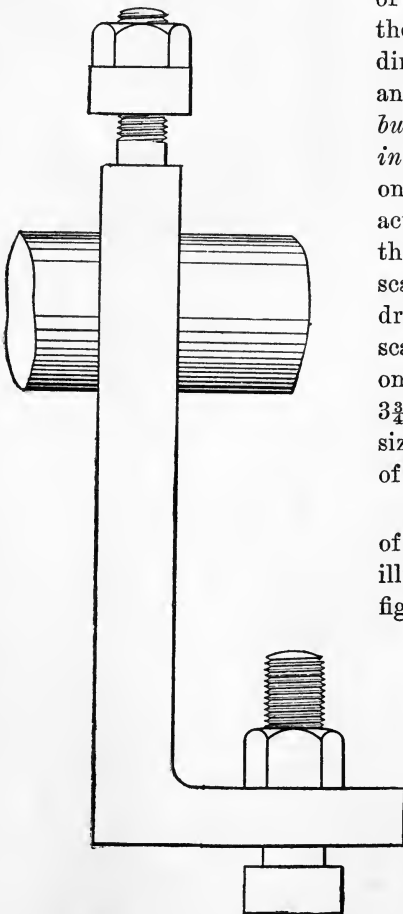

Fig. 54. Side View.
Scale, 3 in. = 1 ft.

PROBLEMS IN GEOMETRICAL DRAWING.

The following examples are to be solved by the use, only, of dividers and rule.

A problem is something to be done, and geometry may be defined as the science of measurement; hence, the relation between geometry and mechanical drawing is very close indeed.

The elementary conceptions of geometry are few:

- 1.—A point.
- 2.—A line.
- 3.—A surface.
- 4.—A solid, and
- 5.—An angle.

All of which elements are used in mechanical drawing.

The importance of a knowledge of geometrical drawing is paramount. The student will find that the figures delineated and explained in the next few pages constantly occur in mechanical drawing. Says Walter Smith, State Director of Art Education in Massachusetts, "I have never known a case where a student did not progress more satisfactorily in his studies after a course of practical geometry."

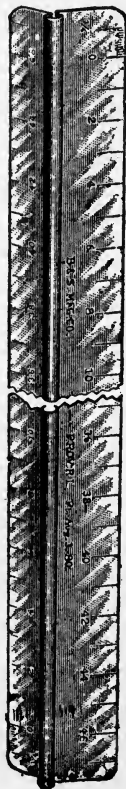

PROBLEMS IN GEOMETRICAL DRAWING.

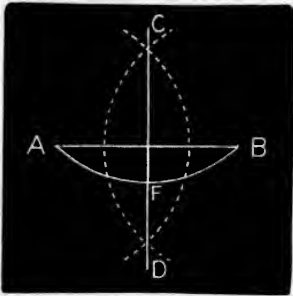

Fig. 60.

EXAMPLE 1.—To bisect (cut in two) a straight line, or an arc of a circle, Fig. 60. From the ends of AB as centers, describe arcs cutting each other at C and D , and draw CD , which cuts the line at E or the arc at F .

EX. 2.—To draw a perpendicular to a straight line, or a radial line to a circular arc, Fig. 60. Operate as in the foregoing problem. The line CD is perpendicular to AB ; the line CD is also radial to the arc AB .

EX. 3.—To draw a perpendicular to a straight line, from a given point in that line, Fig. 61. With any radius from any given point A in the line BC , cut the line at B and C . Next, with a longer radius describe arcs from B and C , cutting each other at D , and draw the perpendicular DA .

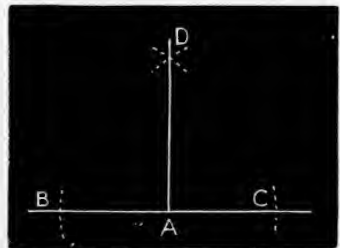

Fig. 61.

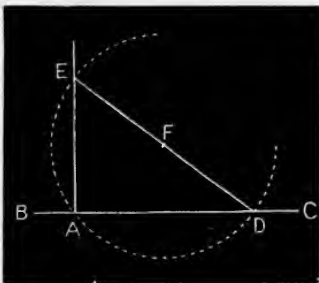

Fig. 62.

Second Method, Fig. 62. From any center F above BC , describe a circle passing through the given point A , and cutting the given line at D ; draw DF , and produce it to cut the circle at E ; and draw the perpendicular AE .

PROBLEMS IN GEOMETRICAL DRAWING.

Third Method, Fig. 63. From A describe an arc EC , and from E with the same radius, the arc AC cutting the other at C ; through C draw a line ECD and set off CD equal to CE , and through D draw the perpendicular AD .

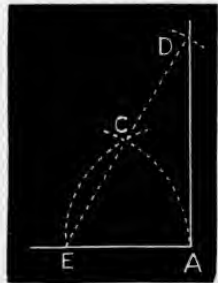

Fig. 63.

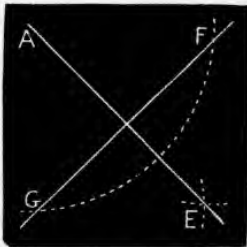

Fig. 64.

Ex. 4.—To draw a perpendicular to a straight line from any point without it, Fig. 64. From the point A with a sufficient radius cut the given line at F and G ; and from these points describe arcs cutting at E . Draw the perpendicular AE .

NOTE.

If there be no room below the line, the intersection may be taken above the line; that is to say, between the line and the given point.

Second Method, Fig. 65. From any two points B C at some distance apart, in the given line, and with the radii BA , CA , respectively, describe arcs cutting at A D . Draw the perpendicular AD .

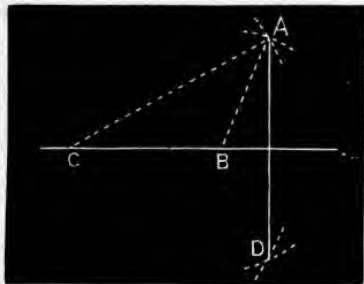

Fig. 65.

Ex. 5.—To draw a parallel line through a given point, Fig. 66. With a radius equal to the given point C from the given line AB , describe the arc D from B taken considerably distant from C . Draw the parallel through C to touch the arc D .

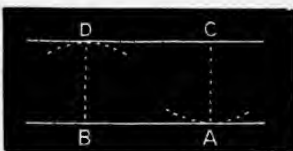

Fig. 66.

Second Method, Fig. 67. From A , the given point describe the arc $F D$, cutting the given line at F ; from F with the same radius, describe the arc $E A$, and set off $F D$, equal to $E A$. Draw the parallel through the points $A D$.

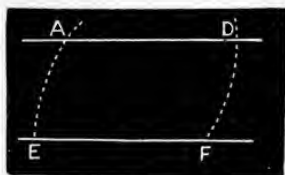

Fig. 67.

When a series of parallels are required perpendicular to a base line $A B$, they may be drawn as in fig. 68 through points in the base line set off at the required distances apart. This method is convenient also where a succession of parallels are required to a given line $C D$, for the perpendicular may be drawn to it, and any number of parallels may be drawn on the perpendicular.

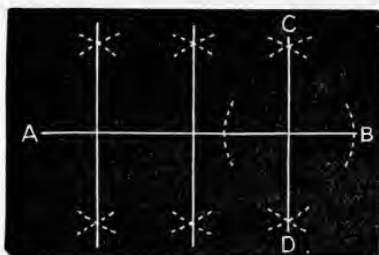

Fig. 68.

Ex. 6.—*To divide a line into a number of equal parts, Fig. 69.*

To divide the line $A B$ into, say, five parts. From A and B draw parallels $A C$, $B D$ on opposite sides; set off any convenient distance four times (one less than the given number), from A on $A C$, and on B on $B D$; join the first on $A C$ to the fourth on $B D$, and so on. The lines so drawn divide $A B$ as required.

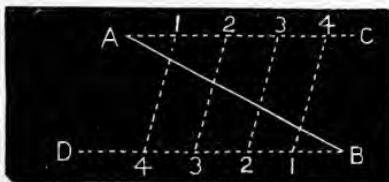

Fig. 69.

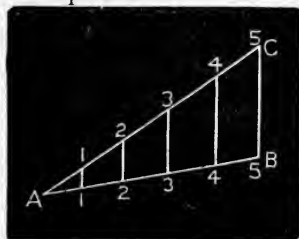

Fig. 70.

Second Method, Fig. 70. Draw the line at $A C$, at an angle from A , set off, say, five equal parts; draw $B 5$, and draw parallels to it from the other point of division in $A C$. These parallels divide $A B$ as required.

PROBLEMS IN GEOMETRICAL DRAWING.

EX. 7.—Upon a straight line to draw an angle equal to a given angle, Fig. 71. Let A be the given angle and $F'G$ the line. With any radius from the points A and F , describe arcs DE , $I'H$, cutting the sides of the angle A and the line $F'G$.

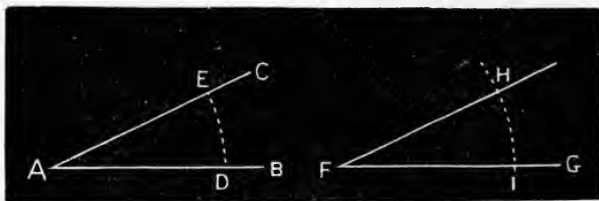

Fig. 71.

Set off the arc $I'H$ equal to DE and draw $F'H$. The angle F' is equal to A as required.

EX. 8.—To bisect an angle, Fig. 72. Let ACB be the angle; on the center C cut the sides at A B . On A and B as centers describe arcs cutting at D dividing the angle into two equal parts.

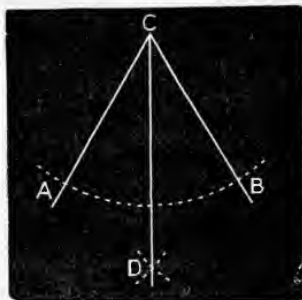

Fig. 72.

EX. 9.—To find the center of a circle or of an arc of a circle. Fig. 73. Draw the chord AB , bisect it by the perpendicular CD , bounded both ways by the circle; and bisect CD for the center G .

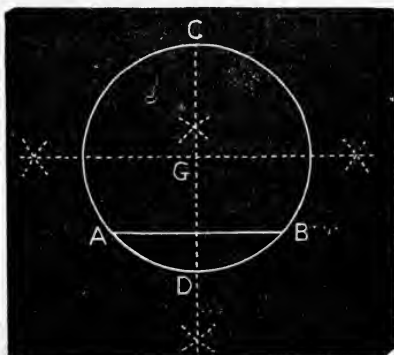

Fig. 73.

PROBLEMS IN GEOMETRICAL DRAWING.

Ex. 10.—*Through two given points to describe an arc of a circle with a given radius, Fig. 74.* On the points A and B as centers, with the given radius, describe arcs cutting at C ; and from C , with the same radius, describe an arc $A B$ as required.

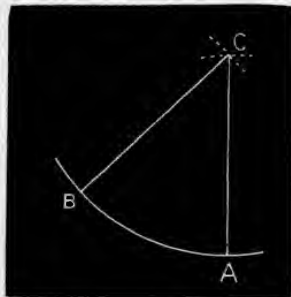

Fig. 74.

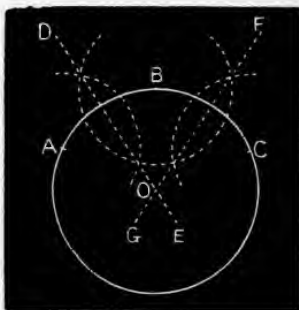

Fig. 75.

Second, for a circle or an arc, Fig. 75. Select three points $A B C$ in the circumference, well apart; with the same radius; describe arcs from these three points cutting each other, and draw two lines $D E, F G$, through their intersections according to Fig. 68. The point where they cut is the center of the circle or arc.

Ex. 11.—*To describe a circle passing through three given points, Fig. 75.* Let $A B C$ be the given points and proceed as in last problem to find the center O , from which the circle may be described.

This problem is variously useful: in finding the diameter of a large fly wheel, or any other object of large diameter when only a part of the circumference is accessible; in striking out arches when the span and rise are given, etc.

Ex. 12.—*To draw a tangent to a circle from a given point in the circumference, Fig. 76.* From A set off equal segments $A B, A D$, join $B D$ and draw $A E$, parallel to it, for the tangent.

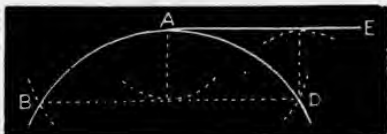

Fig. 76.

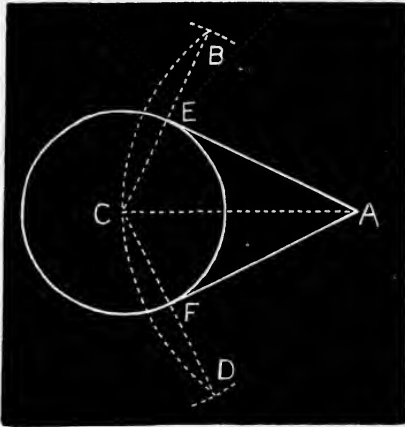

Fig. 77.

Ex. 13.—To draw tangents to a circle from points without it, Fig. 77. From A with the radius AC , describe an arc BD , and from C with a radius equal to the diameter of the circle, cut the arc at BD , join BC , CD , cutting the circle at E , F , and draw AE , AF , the tangents.

Ex. 14.—Between two inclined lines to draw a series of circles touching these lines and touching each other, Fig. 78. Bisect the inclination of the given lines AB , CD by the line NO . From a point P in this line draw the perpendicular PB to the line AB , and on P describe the circle BD , touching the lines and cutting the center line at E . From E draw EF perpendicular to the center line, cutting AB at F , and from F describe an arc EG , cutting AB at G . Draw GH parallel to BP , giving H , the center of the next circle, to be described with the radius HE , and so on for the next circle IN .

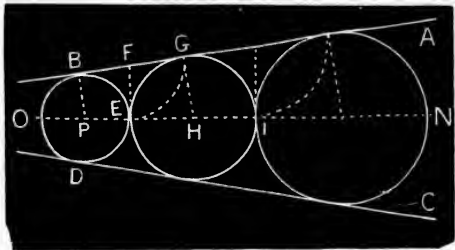

Fig. 78.

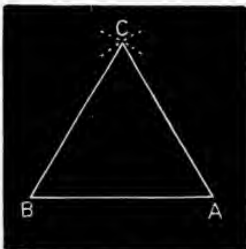

Fig. 79.

Ex. 15.—To construct a triangle on a given base, the sides being given.

First. An equilateral triangle, Fig. 79. On the ends of a given base AB , with AB as a radius describe arcs cutting at C , and draw AC , CB .

Second. Triangle of unequal sides, Fig. 80. On either end of the base AD with the side B as a radius, describe an arc; and with the side C as a radius on the other end of the base as a center describe arcs cutting the arc at E . Join AE , DE .

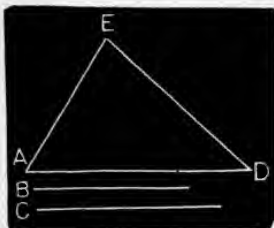

Fig. 80.

This construction may be used for finding the position of a point C or E at given distances from the ends of a base, not necessarily to form a triangle.

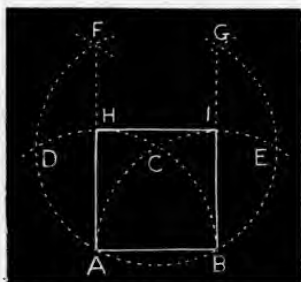

Fig. 81.

Ex. 16.—To construct a square rectangle on a given straight line.

First. A square, Fig. 81. On the ends B A as centers, with the line AB as radius, describe arcs cutting at C ; on C describe arcs cutting the others at D E ; and on D and E cut these at F G . Draw AF BG and join the intersections HI .

Second. A rectangle, Fig. 82. On the base EF draw the perpendiculars EH , FG , equal to the height of the rectangle and join GH .



Fig. 82.

Ex. 17.—To construct a parallelogram of which the sides and one of the angles are given, Fig. 83. Draw the side DE equal to the given length A , and set off the other side DF equal to the other length B , forming the given angle C . From E with DF as radius, describe an arc, and from F , with the radius DE cut the arc at G . Draw FG , EG . Or, the remaining sides may be drawn as parallels to DE , DF .

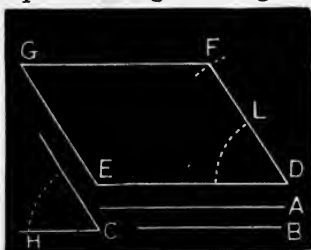

Fig. 83.

PROBLEMS IN GEOMETRICAL DRAWING.

Ex. 18.—To describe a circle about a triangle, Fig. 84.

Bisect two sides AB , AC of the triangle at E , F , and from these points draw perpendiculars cutting at K . On the center K , with the radius KA draw the circle ABC .

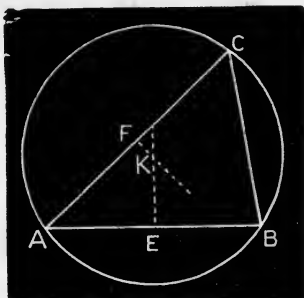

Fig. 84.

Ex. 19.—To describe a circle about a square, and to inscribe a square in a circle, Fig. 85.

First. To describe the circle. Draw the diagonals AB , CD of the square, cutting at E ; on the center E with the radius EA describe the circle.

Second. To inscribe the square. Draw the two diameters AB , CD at right angles and join the points AC , BD to form the square.

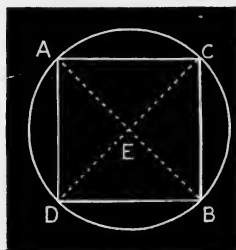

Fig. 85.

NOTE.

In the same way a circle may be described about a triangle.

Ex. 20.—To inscribe a circle on a square, and to describe a square about a circle, Fig. 86.

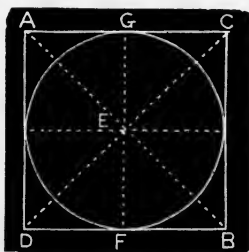

Fig. 86.

First. To inscribe the circle. Draw the diagonals AB , CD of the square, cutting at E ; draw the perpendicular EF to one side, and with the radius EF describe the circle.

Second. To describe the square. Draw two diameters AB , CD at right angles, and produce them; bisect the angle DEB at the center by the diameter FG , and through F and G draw perpendiculars AC , BD , and join the points AD and BC where they cut the diagonals to complete the square.

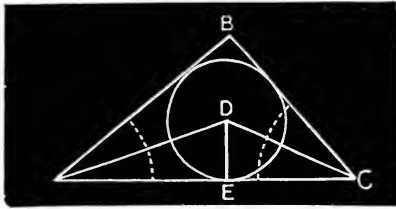

Fig. 87.

and with $D E$ as radius describe a circle.

Ex. 22.—To inscribe a pentagon in a circle, Fig. 88. Draw two diameters $A C, B D$ at right angles cutting at O ; bisect $A O$ at E , and from E with radius $E B$ cut $A C$ at F ; from B with radius $B E$ cut the circumference at $G H$, and with the same radius step round the circle to I and K ; join the points to form the pentagon.

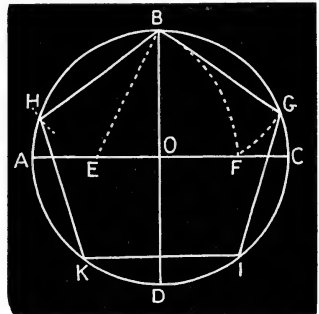

Fig. 88.

Ex. 23.—To construct a hexagon upon a given straight line, Fig. 89. From A and B the ends of the given line describe arcs cutting at G ; from G with the radius $G A$ describe a circle. With the same radius set off the arcs $A C, C F$ and $B D, D E$. Join the points so found to form the hexagon.

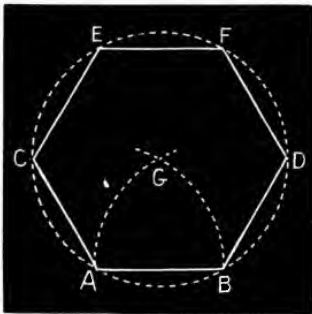

Fig. 89.

Ex. 24.—To inscribe a hexagon in a circle, Fig. 90. Draw a diameter $A C B$; from A and B as centers with the radius of the circle $A C$, cut the circumference at D, E, F, G , and draw $A D, D E$, etc., to form the hexagon.

The points $D E$, etc., may be found by stepping the radius (with the dividers) six times round the circle.

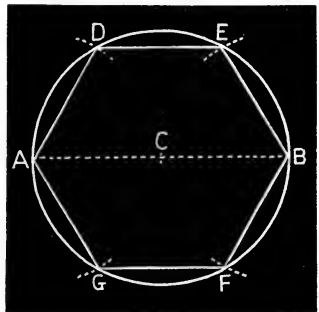

Fig. 90.

Ex. 25.—To describe an octagon on a given straight line,

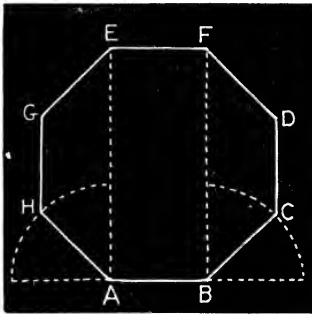

Fig. 91.

Ex. 26.—To convert a square into an octagon, Fig. 92.

Draw the diagonals of the square cutting at e ; from the corners $A B C D$, with $A e$ as radius, describe arcs cutting the sides at G, H , etc., and join the points so found to complete the octagon.

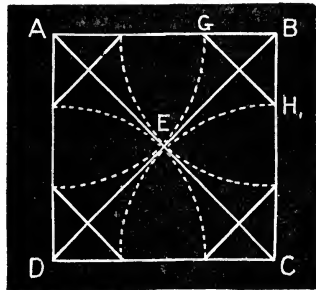

Fig. 92.

Ex. 27.—To inscribe an octagon in a circle, Fig. 93.

Draw two diameters $A C, B D$, at right angles; bisect the arcs $A B, B C$, at E, F , etc., to form the octagon.

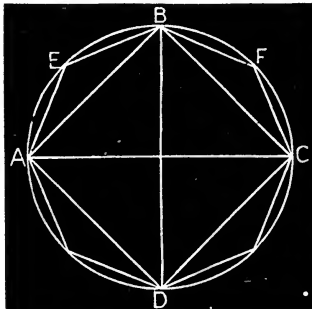

Fig. 93.

Ex. 28.—To describe an octagon about a circle, Fig. 94.

Describe a square about the given circle $A B$, draw perpendiculars H and K , to the diagonals, touching the circle, to form the octagon. Or, the points H, K , etc., may be found by cutting the sides from the corners, by lines parallel to the diagonals.

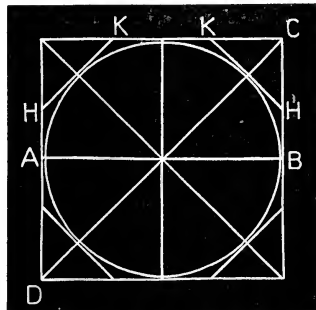

Fig. 94.

from the corners, by lines parallel to the diagonals.

PROBLEMS IN GEOMETRICAL DRAWING.

EX. 29.—To describe an ellipse when the length and breadth are given, Fig. 95.

On the center C with A, E , as radius, cut the axis AB at F and G , the foci; fix a couple of pins into the axis at F and G , and loop on a thread or cord upon them equal in length to the axis AB , so as when stretched to reach the extremity

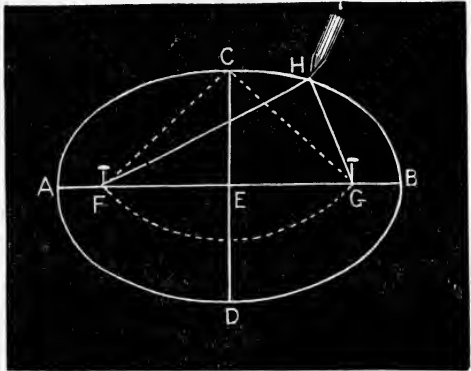

Fig. 95.

C of the conjugate axis, as shown in dot-lining. Place a pencil or drawpoint inside the cord, as at H , and guiding the pencil in this way, keeping the cord equally in tension, carry the pencil round the pins F, G , and so describe the ellipse.

Second Method. Along the straight edge of a piece of stiff paper mark off a distance ac equal to AC , half the transverse

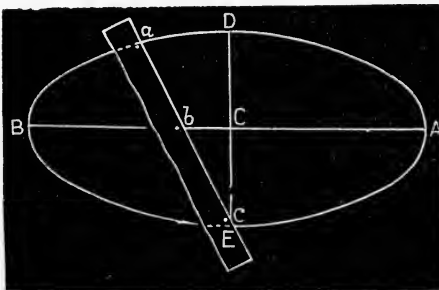

Fig. 96.

axis; and from the same point a distance ab equal to CD , half the conjugate axis. Place the slip so as to bring the point b on the line AB of the transverse axis, and the point c on the line DE ; and set off on the drawing the position

of the point a . Shifting the slip, so that the point travels on the transverse axis, and the point c on the conjugate axis, any number of points in the curve may be found, through which the curve may be traced. See fig. 96.

NOTE.—The ellipse is an oval figure, like a circle in perspective. The line that divides it equally in the direction of its great length is the *transverse axis*, and the line which divides the opposite way is the *conjugate axis*.

“POINTS” RELATING TO FREE-HAND AND MECHANICAL DRAWING.

The application of the science of geometry to the drawing-board is absolutely necessary to success, for the reason that the whole fabric of mechanical drawing rests on the principles of geometry, which is well termed the Science of Measurements.

A good draughtsman leaves his work in such a state that any competent person can without difficulty ink in what he has drawn.

The criterion of a good set of drawings is that with a properly prepared specification they are complete in themselves and require no explanation.

A “break” in a figure or object in a drawing is shown in rough irregular lines as in fig. 134 on page 131; this is useful when the paper is not large enough to show the whole.

Never use a sloping line in writing fractions on a drawing. The objection arises from the fact that such a dimension as $1\frac{3}{8}$, if written with the inclined line, unless very distinctly executed, may be read as $\frac{1}{8}$.

In inking do not draw the lines further than you wish them to go, but in penciling it is well to extend the lines, free up.

Never use a scale for a ruler.

Do not overload the pen with ink.

Having filled the pen, nearly close the nibs and try the width of the line on a piece of paper or the margin of the drawing.

Never refill or lay the pen aside without first cleaning it.

NOTE.—Many of these “points” are repetitions, with but little variation from the way they have been previously stated; they are thus repeated, to emphasize their practical worth.

“POINTS” RELATING TO DRAWING.

Section lines should be the last inked and always without previous penciling.

Center lines are necessary in working drawings.

In choosing T-squares, care should be exercised to see that the head slides up and down the *left* hand side of the board easily, and that when pressed against the board with the left hand there is no “slogging” of the blade up or down, or in other words, that the head is bearing firmly for its whole length against the board.

The best place for the title of a drawing is said to be the upper left hand corner; this facilitates the filing of the sheet.

Never use a soft pencil except for finishing in shadow lines.

The rubber should always be kept clean.

Great care should be taken to keep drawing boards out of the way of heat or damp, as these cause the wood to warp.

Circles and curves are to be “inked in” first. Ink the smallest and afterwards the larger ones.

Do not press heavily on the pencil so as to cut the paper, but draw lightly, so that the mark can be erased and leave no trace, especially if the drawing is to be inked.

The draughtsman should commence his work at the top of the paper, keeping the lower part covered over until he needs to use it.

Shade lines should be avoided in all working drawings, as their use interferes with accurate measurements.

To make ink stick to the tracing cloth, with a woolen cloth rub some powdered chalk or pounce over the surface on which the ink lines are to be drawn, then wipe the surface clean and use a good quality of ink.

For striking small circles a small bow pen should be used.

“POINTS” RELATING TO DRAWING.

To fix led pencil marks or sketches so that they cannot be readily erased, sponge them with milk carefully skimmed, then lay blotting paper over them and iron with a hot flat-iron.

To have the ink preserve its fluidity and to keep out all dirt and dust, keep the cover on the ink slab; the mistake is often made of putting too liberal a supply of water in ink well, which causes a waste of both time and ink; no more should be prepared than to meet immediate requirements.

Always draw on the right side of the sheet, which can be found by holding the sheet up to the light and looking across its surface with the eye nearly in the same plane as the paper; note which side is the smoothest and has the least number of blemishes on it; this is the right side to draw on.

As to sharpening pencils, it is always best to cut a chisel point on the pencil used for drawing, and put a circular point on the pencils in the bow pencil and pencil leg. The chisel point makes a finer line and lasts much longer than a round point.

The varnish used in many large drawing rooms is simply white shellac dissolved in alcohol; it requires a little experience to mix these to a proper consistency, but this is soon acquired.

Never sharpen your pencil over the drawing.

The T-square belongs to the left side of the drawing-board, and is operated by the left hand. The right hand should be kept free for the purpose of picking up pencil, pen and bows, adjusting and marking off. The left hand controls the T-square and the triangle that slides along the upper edge of the square; the right hand is for the instruments.

A center line of a drawing is the line upon which the figure

"POINTS" RELATING TO DRAWING.

is to be constructed; the center line is the first line to be drawn.

The advantage of a paper rule or scale is that the paper will expand and contract under varying degrees of atmospheric moisture the same as the drawing does.

Avoid rubbing out and constantly cleaning the drawing with india rubber; if wrong lines are made or it is desired to make alterations the part to be changed should be rubbed out and completely re-drawn.

When using the bows see to it that the steel-pointed leg that is put down first on the paper, to secure a center for a curve or a circle, is a trifle longer than the pencil or pen leg.

To clearly indicate the position of a center which is to be used again, lightly pencil a small circle about it; never put the point of a pencil in the center hole to enlarge or blacken it; the prick point made by the dividers and needle points should be no more than can be just seen, hence the circle to be made as advised above.

Be particular in having the legs of the dividers exactly the same length, and sharp, so that in pricking off distances, and dimensions, and centers, the indent or hole made in the paper is as small as possible.

The term "plane" means a perfect flat surface; that is, something which has length and breadth but no thickness.

The best way to indicate on the drawing the surfaces which are to be finished is to write on the lines which represent the finished surfaces "finished," tool-finish, or "faced," according to the degree of finish required. The single letter *f* is frequently used.

Avoid fingering the drawing sheet as much as possible; in pointing to any part of the drawing use a pencil and not the finger.

“POINTS” RELATING TO DRAWING.

Remember that a drawing is made to be read.

The skill in inking does not depend on the fineness of the line, but on its clearness.

A soft pencil should never be used on a mechanical drawing unless in rare cases when it is used for pencil shading; the hardness or softness of pencils are denoted by letters.

Never ink any portion of a drawing until the penciling is entirely finished.

Stretching or pasting the paper to the board is very seldom resorted to, for the reason that the mechanical drawings are *to scale* and the paper is natural when pinned to the board and more correct than if under a strain. Mechanical drawings are always required in practice *right away*, and time would be wasted and lost in damping and pasting and drying again.

GEAR WHEELS.

A *gear* is primarily a toothed wheel; gearing is a train of toothed wheels for transmitting motions; there are two chief sorts of toothed gearing, viz., spur gearing and bevel gearing.

A *spur wheel* has teeth around the edge pointing to the center; commencing at the center, a spur wheel may be said to consist of a hole, square, octagonal or round for its axle or shaft; a hub; the web, body or arms; a rim, and the teeth; fig. 111.

A *spur wheel* has teeth on its circumference which run parallel to its shaft, see fig. 102; wheels as shown in fig. 109 are termed *helical wheels*; these are similar to spur wheels except their teeth are arranged upon different angles to the shaft.

A *bevel* is a slant or inclination of a surface from a right line, hence a bevel gear wheel is one whose teeth stand beveling or at an oblique angle to the shaft, or towards the center. Fig. 104.

The *addendum circle* of a toothed wheel, is as shown in illustration, fig. 100; *addendum* means "something added," and as shown in the figure, it is the part added beyond the "pitch line."

The *pitch line* is the most important one in gearing; the "pitch line" or "pitch circle" is supposed to be the working circle. P—P in fig. 111.

The *periphery* of a wheel is the extreme circumference. N in fig. 111.

Fig. 97.

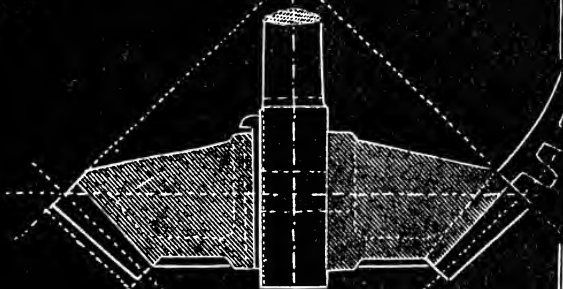

Fig. 98.

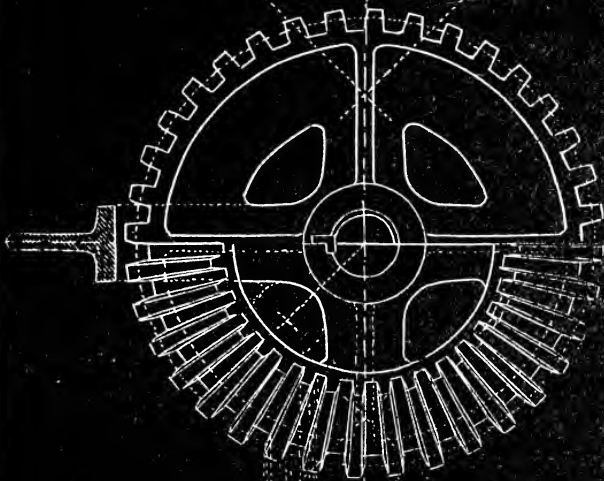
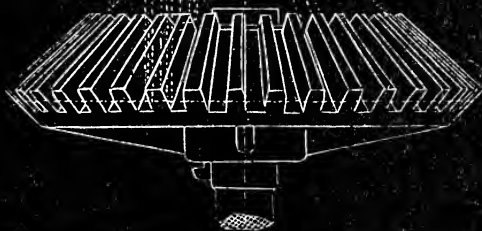

Fig. 99.



GEARING.

The diameter of both spur and bevel wheels is measured and calculated neither from the outside nor from the bottom of the teeth, but on the pitch circle. When we speak of the diameter of a spur or bevel wheel, we mean the diameter of the pitch circle, without any reference to the form of tooth.

A cog wheel is the general name for any wheel which has a number of cogs placed around its circumference.

When the teeth of a wheel are made of the same material and formed of the same piece as the body of the wheel, they are called *teeth*; when they are made of wood or some other material, and fixed to the circumference of the wheel, they are called *cogs*.

A pinion is a small wheel. When two toothed wheels act upon one another, the smallest is generally called the pinion. The terms *trundle* and *lantern* are applied to small wheels having cylindrical bars instead of teeth. The teeth in pinions are sometimes termed *leaves*; in a trundle, *staves*.

The wheel which acts is called a *leader* or *driver*; and the wheel which is acted upon by the former is called a *follower*, or the *driven*. When a screw or *worm* revolves in the teeth of a wheel, the latter is termed a *worm wheel* or *worm gear*.

NOTE.—The number of teeth, their proportions, pitch and diameter of pitch circle are frequently determined on the "Manchester" principle. This system originated in Manchester (Eng.), and is now generally used in the United States for determining diameters and number of teeth, which, of course, regulate speeds. The principle is not applicable to large wheels, but is limited in its application to small wheels, or wheels having "fine pitch," as will be seen in the following explanation, which we introduce as very useful and indispensable knowledge for the acquisition of the student in mechanical drawing.

The "pitch" of teeth has already been stated to be the distance from center of one tooth to the center of another on the "pitch line," measured on the chord of the arc. In determining the number of teeth or pitch of wheels on this principle, the pitch is reckoned on the *diameter* of the wheel, in *place of the circumference*, and distinguished as wheels of "4 pitch," "6 pitch," "8 pitch," etc. In other words, this means that there are four, six, or eight teeth in the *circumference of the wheel* for every inch of diameter.

GEARING.

See fig. 108. When a pinion acts with a rack having teeth, we speak of *rack* and *pinion*. When the teeth are on the inside of the rim, and not on the periphery, the wheel is termed an *internal gear*, see fig. 110. Two wheels acting upon one another in the same plane are called *spur gear*; the teeth are parallel with the axis. When wheels act at an angle, they are called *bevel gear*.



Fig. 100.

All parts of gear-wheel consist of portions, to which have been given generally accepted names. Fig. 100 shows the "addendum circle" and the "pitch line" as marked. The teeth and rim are shown in white.

Miter wheels are bevel wheels of the same size, working at right angles with one another, see fig. 106.

Diametral means pertaining to a diameter or the length of a diameter; hence a diametral pitch is a system of measures or enumeration based upon the diameter instead of the circular pitch line; it is used very generally in spacing for fine tooth gear. Wheels of this description usually have their teeth cut in a gear-cutting machine, *i. e.*, medium and fine tooth gears.

The circular pitch line, as opposed to the diametral pitch, is the same as the pitch circle. It is a line which bisects all the teeth of a toothed wheel.

The rolling circle is the same as the circular pitch line.

GEARING.

In fig. 101 is shown the halves of a wheel and pinion in gear; AB is the line of centers and CC and CC are the pitch circles touching at C ; the divisions Ac and Bc , of the line of centers, being the pitch-radii of the wheels. The arc of the pitch circle, between P and P , is the pitch of the teeth, and it comprises a tooth and a space.

The difference between the width of a space and the thickness of a tooth is called clearance or side clearance.

The play or movement permitted by clearance is called the backlash; clearance is necessary to prevent the teeth of one wheel becoming locked in the spaces of the other.

Wheels are in gear or geared together when their pitch lines engage, *i. e.*, when the pitch circles meet.

Wheels to be geared together must have their teeth spaced the same distance apart, or in other words, of the same pitch.

The teeth of spur wheels are arranged on its periphery parallel to the wheel axis, or shaft on which it is hung.

The teeth of a bevel wheel or bevel gears are always arranged at an angle to the shaft.

When the *teeth* of bevel gears form an angle of 45° they are called mitre wheels.

Mitre wheels to gear must be of equal sizes.

A crown wheel is a disc that has teeth which are radial to the shaft; that is, teeth on a flat circular surface all pointing to the center of the wheel.

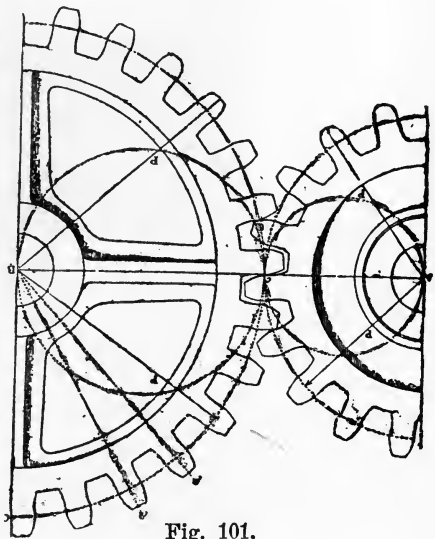

Fig. 101.

SPUR-WHEELS.

A rack has teeth on a flat surface or plane all parallel to one another.

A *trundle wheel* has no teeth, properly speaking. Instead of teeth, as shown on illustration of a rack, it has rungs arranged like the rungs of a ladder between two walls, or pins fixed in one end only. See page 137.

A bevel wheel and pinion must be made to suit one another by both having teeth forming together an angle of 90° , therefore they are pairs, or proportioned in the number of teeth one to the other. Any other proportion used would not exactly gear and would be termed a "Bastard" gear.

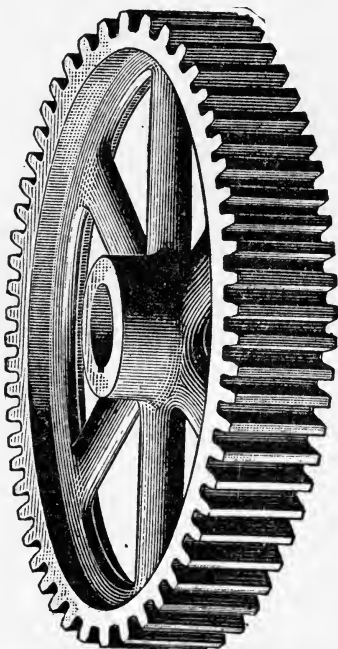

Fig. 102.

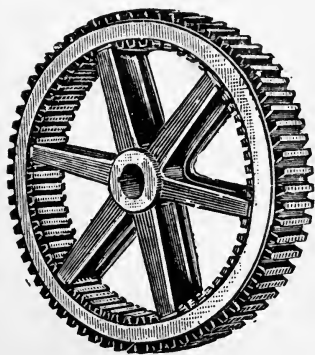

Fig. 103.

A flange or addition to the end of a tooth and the rim connecting them together is used to strengthen the teeth. This extends from the root to pitch line when the wheel and pinion are both flanged; if only one is flanged it extends from the root to the addendum.

BEVEL-GEAR.

A gear cut by machine is called a *cut gear*. It has teeth with less clearance than cast wheels, which are not so true or perfect, and therefore require more clearance.

A worm gear is a spur wheel with teeth at an angle to the axis, so as to work with a worm

which is a *screw*, or has teeth shaped in the form of a spiral wound round its circumference; the screw or worm is called an endless screw, because it never comes to a stopping place in the circumference of the wheel.

The diameter of a wheel or pinion is invariably the diameter measured on pitch-circle, except it is specially described otherwise, thus the diameter "over all" etc.

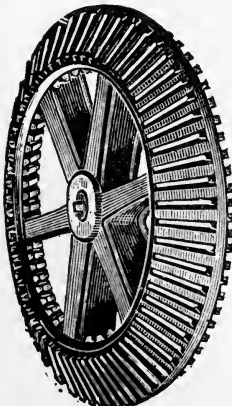

Fig. 105.

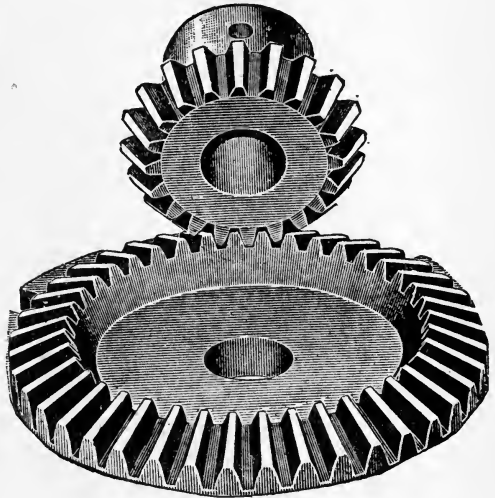

Fig. 104.

The shape of the curved face of the teeth of gears extending from the root to the addendum is the curve conforming to the passage of the teeth described on its fellows entering and leaving, as they rotate or roll together on their pitch circles.

The curve of teeth outside the pitch circle is called "the face," and the curve from pitch circle to root is called "the flank."

An internal or annular gear wheel is one in which the faces of the teeth are within and the flank without the pitch

MITRE-GEAR.

circle, hence the pinion operates within the wheel. See fig. 110 page 133.

In internal geared wheels there is almost an entire absence of friction and consequent wear of the teeth, as compared to ordinary spur gearing.

A worm with even a light load is liable to heat and cut if run at over 300 feet of rubbing surface travel. The wheel teeth will keep cool, as they form part of a large radiating surface; the worm itself is so small that its heat is dissipated slowly.

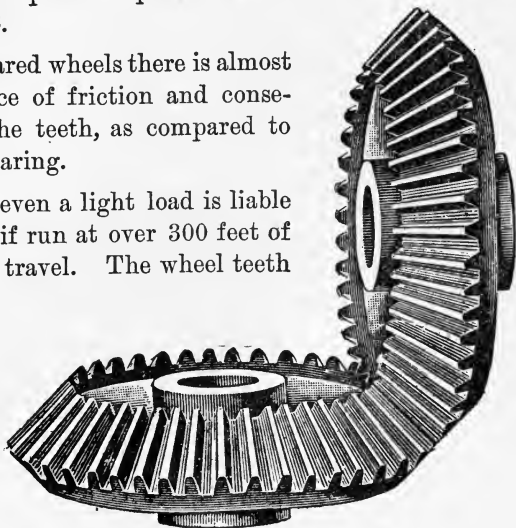

Fig. 106.

A worm throws a severe end thrust or strain on its shaft.

Fig. 102 shows a spur-wheel, a general perspective view which is not a working drawing, but conveys a good idea of this numerous class of gears.

A *spur mortise wheel* is similarly shown in fig. 103; it is very like in appearance to the spur-wheel shown, but it differs essentially in that the teeth of the latter are separate cogs, fixed in singly to the rim.

Fig. 107.

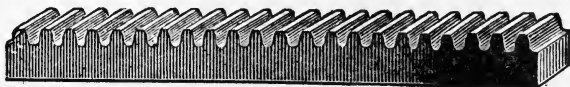

NOTE.—The teeth of spur-wheels cast from a pattern must of necessity be larger at one side than at the other, because the teeth must have taper to permit the extraction of the pattern from the mould; therefore, in fixing wheels to gear, the large side of one should meet the smaller side of the other; should the two large sides come together the teeth will meet only at the large side, and the teeth will probably break away from the excessive strain on that point.

Fig. 104 shows a pair of bevel wheels in gear as described on page 129; fig. 105 illustrates a bevel mortise wheel; *i. e.*, one having cogs inserted in its rim.

Fig. 106 represents a pair of miter-wheels in gear; it will be noted that the shafts, when connected, will be at right angles to each other, the wheels being in all particulars

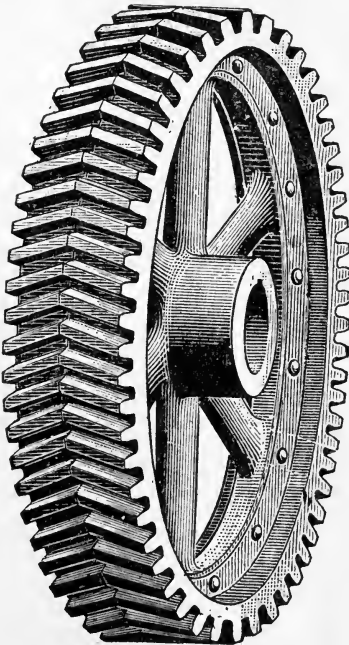

Fig. 109.

GEARING.

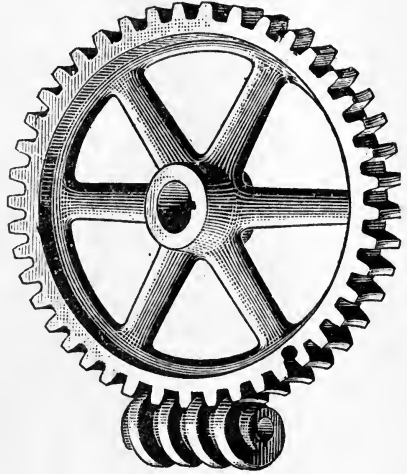

Fig. 108.

of the same dimension; the figure answers the purpose of a much longer description if given in words.

A mitre-wheel can easily be known by putting a square upon the face of the teeth, which are always at an angle of 45° with one another, irrespective of size.

Fig. 107 represents a rack; the teeth in this form of gear are shaped similarly to those in the spur-wheel, shown on page 128, with the difference that the teeth of one are on a circle and on the other made on a straight line.

INTERNAL GEAR WHEEL.

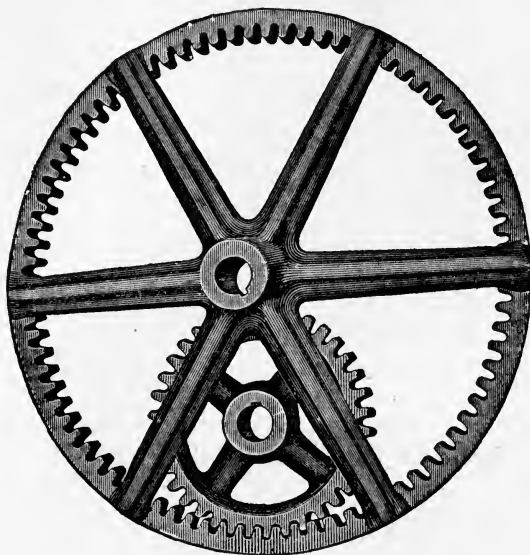

Fig. 110.

Figs. 97, 98 and 99, page 125, represent three views of a mitre-wheel. *The plan* shows the outline in one half and the finished teeth in the other half. *The sectional* elevation is shown above the plan, projected from the center line, looking down upon the plan. The lower figure represents *a side elevation* projected from the plan.

It will be observed that at the left of the plan is shown a section of the arm of the wheel.

Fig. 108 illustrates a worm and a worm wheel, sometimes called screw gears. This is a slow but powerful method of transmitting power, one revolution of the worm only moving the wheel the distance of one tooth and space.

Fig. 109 represents a gear with helical teeth. It is similar to a spur-wheel, and is used in place of same in heavy and slow moving machinery, the formation of teeth preventing—in large measure—the jar or concussion noticeable in common spur-gears.

GEARING.

Friction gearing-wheels are those which communicate motion one to the other by the simple contact of their surfaces.

In frictional gearing the wheels are toothless and one wheel drives the other by means of the friction between the two surfaces which are pressed together.

Grooved friction wheels are used to give greater cohesion than can be obtained by the plain surface.

Gear wheel teeth should be lubricated or greased.

Friction gear should not be lubricated or greased.

DESIGNING GEARS.

To accurately divide the pitch circle of a gear wheel by hand requires both patience and skill. On the accuracy of spacing lies the essential requisite of a good gear wheel.

The drawing in this plate, fig. 111, illustrates a pair of spur-wheels, shown in gear, the office instructions for which being:

“Required, *a detail plan* of a pair of spur-wheels; dimensions: wheel, 76 teeth, $3\frac{1}{2}$ inches pitch, 7-inch eye, 6 arms; pinion, 19 teeth; scale, $1\frac{1}{2}$ inches = 1 foot.”

The drawing, as illustrated, is the result of the above instructions, all pencil lines being removed, and this result is worked out as follows:

$76 \text{ teeth} \times 3\frac{1}{2} \text{ inches, pitch} = 266 \text{ inches in circum.} = 7 \text{ ft. } .01\frac{1}{8} \text{ in. diam.} = 3 \text{ ft. } 6\frac{1}{8} \text{ in. radius; with this measurement as represented on scale draw line } P P \text{ on drawing. This is called the pitch line.}$

Draw next diameter line, produce or extend this diameter line for pinion, and with radius of $10\frac{1}{8}$ (19 teeth $\times 3\frac{1}{2}$) from pitch line of wheel, draw pitch line of pinion.

NOTE.—Friction gear may be used where the speed is so high that noise would be caused by toothed gearing; they may be used when the motion is intermittent, or often put into or out of gear without stopping the machinery.

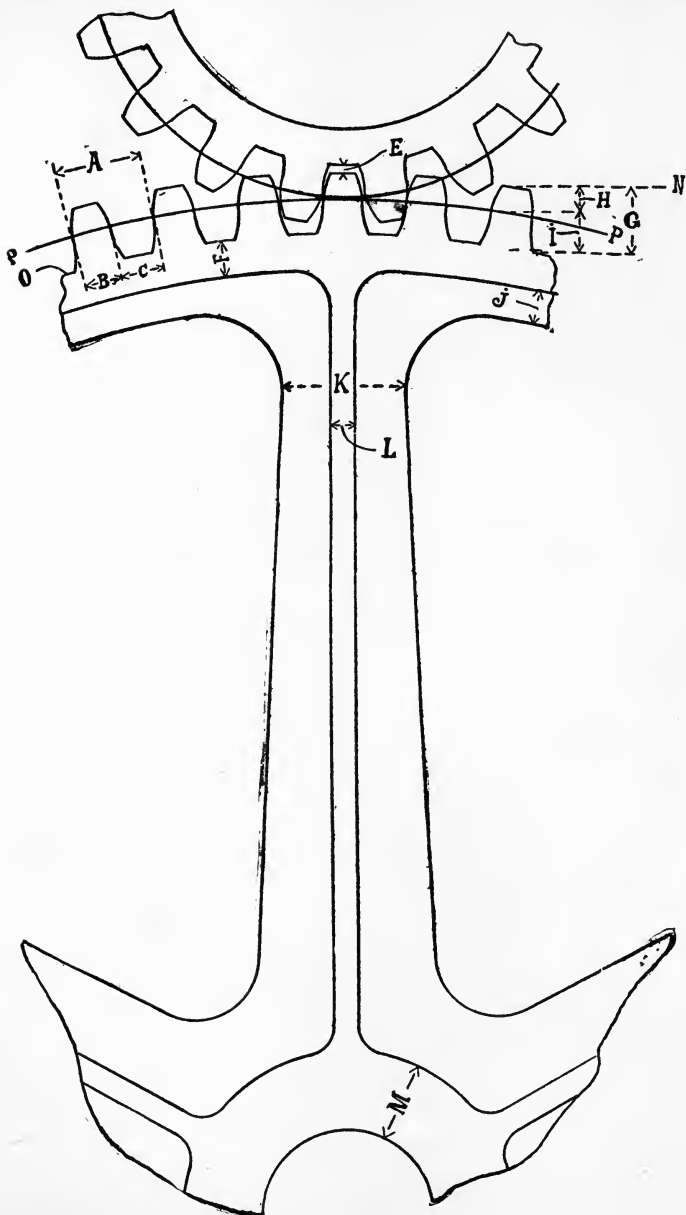

Fig. 111.

GEARING.

Take any point in this pitch line of wheel, mark off $3\frac{1}{2}$ inches as represented on scale, mark this around the pitch line, it will be the center of each of the 76 teeth; then the breadth or thickness of each tooth ($= \text{pitch} \times 0.475$) must be marked from these centers, then mark from $P I$, length of tooth to point ($= \text{pitch} \times 0.35$) and $P I$ to root ($= \text{pitch} \times 0.4$) draw circles for outside of teeth N and root of tooth O ; now with compass set to the pitch ($3\frac{1}{2}$) of the wheel, draw the outer portion from pitch line of tooth.

The radius will center in the pitch line of next tooth where thickness of tooth has been marked; after finishing outer portion of both sides of teeth, set the compass from center of tooth with radius to the thickness marked on pitch line and draw the portion of tooth from pitch line to root.

Now mark off with dividers and draw thickness of rim ($= \text{pitch} \times 0.5$), divide this line into six parts, draw radii for centers of arms; draw the bore hole $7''$ and the thickness of metal for hub same as pitch.

On radii lines of arms, draw the breadth of arm at rim—pitch and thickness of tooth—increase in breadth approaching the center ($1''$ per foot), draw thickness of feather of arm ($= \text{pitch} \times 0.35$); draw web on inside of rim ($= \text{pitch} \times 0.375$); fill in arcs for the joining of arms in rim and hub (radii $= \text{pitch} \times 0.8$) and feather to rim and hub (radii $= \text{pitch} \times 0.37$).

Proceed in similar manner, completing the teeth of pinion, and when pencil lines are all in, ink the drawing, erasing all needless lines.

PP shows the pitch line; B , thickness of tooth; c , breadth of space; A , the pitch; E , clearance of teeth; N , the addendum of tooth; O , the root of tooth; H , length of tooth from pitch line to point; I , length of tooth pitch line to root; G , whole length of tooth; F , thickness of rim; J , web or feather on rim; K , breadth of arm; L , thickness of feather; M , hub, or thickness round the eye.

NOTE.—But it must be remembered that no fixed standard has ever been agreed on for these proportions and workshops differ considerably in practice.

GEARING.

In designing gears to transmit power the stress on a tooth is calculated; it determines the breadth or width also and the thickness of the tooth on pitch line; the space between the teeth is in proportion to the thickness of tooth, and the thickness of both combined (one tooth and one space), measured on the pitch line or circle, is the pitch of the wheel.

From the pitch all the proportions and measurements for the sizes and strength of the parts of the wheel are taken *by rule*, and a symmetrical form is produced.

In machine drawing the practice is to represent wheels by circles only; the teeth are never shown except on enlarged details and then only in very rare instances; the circles drawn are always the *pitch lines* or the rolling points of contact of the wheels.

The addendum circle is seldom if ever used in practical drawing. Should it be necessary to show it in an exceptional case the circle would be represented by "dotted" line.

The shape of tooth and mode of constructing it, as practiced in drawing offices, differs from the true curve theoretically of the tooth, although very minutely.

In all calculations for the speed of toothed gears the estimates are based upon the pitch line, the latter standing in the same place as the circumference of a pulley.

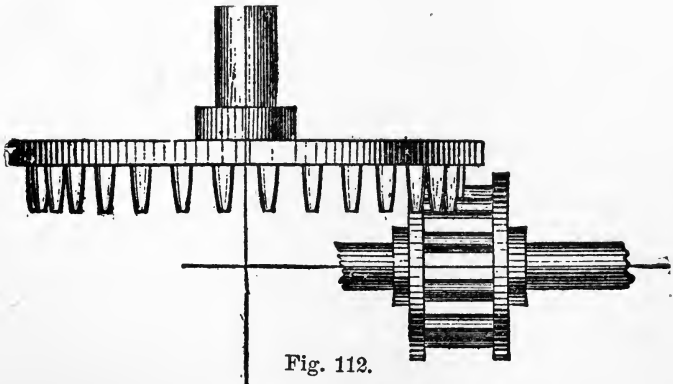

Fig. 112.

Trundle-Wheel. See page 129.

GEARING.

The decimal proportions already given in example, page 134, are adopted in many workshops. Many others use the proportions approved of by Sir William Fairbairn, which are:

Table of proportion of gears:

Depth of tooth above pitch line....	.35	of the pitch.
" below pitch line....	.40	“
Working depth of tooth.....	.70	“
Total depth of tooth.....	.75	“
Clearance at root.....	.05	“
Thickness of tooth.....	.45	“
Width of space.....	.55	“

Steel Gears.—There is great economy in the use of cast-steel over cast-iron in gears; the average life of the former is nearly twice as great as that of cast-iron gears. And, apart from their longer life and efficiency, there is less danger of breaking.

The most accurate teeth, strongest and most uniform in wearing, are to be found in steel gears cut from solid stock, or made by cutters of proper shape.

Skew gearing are bevel wheels working out of center; the teeth do not form radial lines from wheel center.

Covers for Gears.—Experience of a painful and costly nature has shown in thousands of cases the advantage of covering, not only belting, but gearing, with special safeguards against contact with the person and clothing of those employed in its operation. A factory act, so-called, is in force in England to safeguard the public and employees against this danger. A feature of American practice is the increased use of covers for gears that were formerly exposed.

NOTE.—This factory act is the outcome of labor agitation, and it is administered in a peremptory way; great precautions being taken to have all gearing perfectly safe, and cased about, in lathe, drill and wood-working machinery; the gears are enclosed in malleable iron or brass cases or covering, which fit close to the wheels and occupy very little room; they are found an advantage instead of an encumbrance, and protect the gears from chippings, etc.

GEARING.

Train of Gears.—When two wheels mesh—that is, engage with each other—as in fig. 101, one axle revolves in the opposite direction to the other; but when internal gears mesh as shown in fig. 110, the shafts revolve in the same direction; three or more gears running together are often called a *train of gears*.

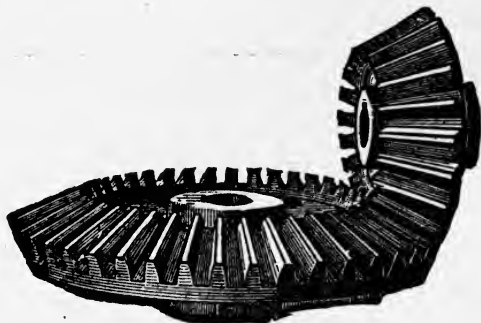

Fig. 113.

When the teeth of gear wheels become worn it is well to thin down the edges with a smooth file, thereby bringing the strain along the center of the tooth; then they will not break unless the strain is sufficient to break off the whole tooth.

Maximum speed of gears under favorable conditions for safety are comparatively—

Ordinary cast-iron wheels . . .	1,800 feet per minute.
Helical “ “ . . .	2,400 “
Mortise wood cog “ . . .	2,400 “
Ordinary cast-steel wheels . . .	2,600 “
Helical “ “ . . .	3,000 “
Cast-iron machine cut wheels.	3,000 “

It is not, however, advisable to run gears at their maximum speeds, as great noise and vibration are caused.

NOTE.—*Helical Teeth*—In recent years the speed at which gearing is run has been greatly increased. A striking instance is that of a pair of *cast-iron* helical wheels, 6 ft. 3 in. diameter, 12 in. wide, making 220 revolutions per minute, the speed of the pitch line being 4,319 ft. per minute; these wheels are running continuously and with little noise. There is also a *cut gear* in a mill in Massachusetts 30 ft. in diameter, and the speed of pitch line is 4,670 ft. per minute. This is probably the highest speed ever regularly run.

WORK BENCHES.

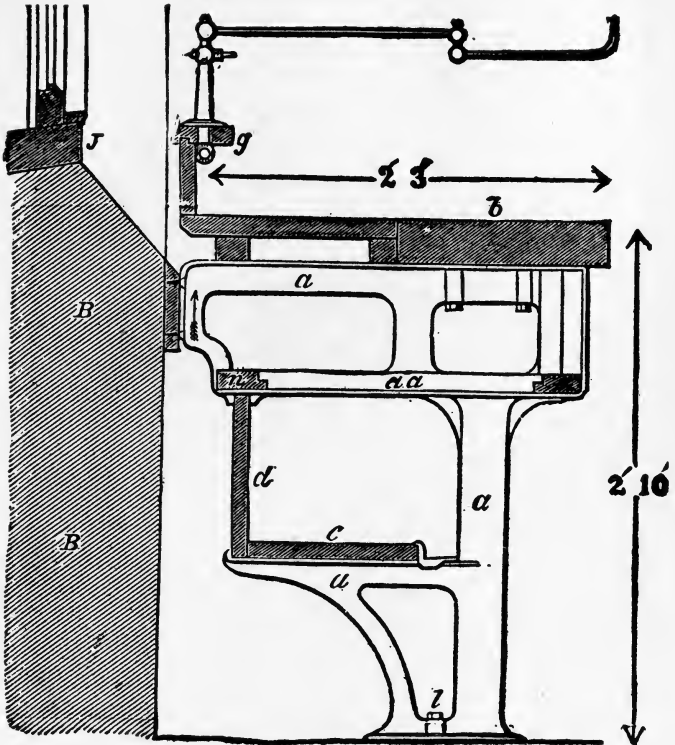

Fig. 114.

NOTE.—“The correct manipulation of metal-working tools comes natural to many; but where one such man is found, there will be a dozen others who can acquire the necessary skill to be called good machinists only after careful study and close application of the most thorough instruction. The time required to accomplish this will depend entirely on the man and the conditions under which he works. Under favorable circumstances two to six years will be required.”—W. H. VAN DEVOORT.



BENCH

AND

WISE

As to the workman, I advise him to do his work well; he is a lucky man who, early in life (but better late than never), becomes impressed with the idea that honest and unremitting endeavor to do the best that he is capable of is the surest way to success.

TEMPERING AND HARDENING METALS.

To temper steel or other metal is to bring it to a proper degree of hardness and elasticity for use; the reason tempered steel cuts common steel or iron is because it is harder.

Steel is said to be *hardened* when it is as hard as it is practicable to make it, and to be *tempered* when, after having been hardened, it is subjected to a less degree of heat, which partly but not altogether destroys or removes the hardness.

Steel plunged into cold water when it is itself at a red heat becomes excessively hard. The more suddenly the heat is extracted the harder it will be. This process of "hardening," however, makes the steel very brittle, and in order to make it tough enough for most purposes it has to be "tempered."

Steel is tempered by being first heated to a high temperature and then rapidly cooled; it is then reheated to the desired temperature and cooled again.

The process of tempering depends upon a characteristic of steel, which is that if (after hardening) the steel be reheated, as the heat increases, the hardness diminishes.

In order to produce steel of a certain degree of toughness, without the extreme hardness which causes brittleness, it is gradually reheated, and then cooled when it arrives at that temperature which experience has shown will produce the limited degree of hardness required. Advantage is taken of this change of color in the process of tempering, which for ordinary tools is conducted as follows: The workman places the point or cutting-end of the tool in the fire till it is of a cherry-red heat, then hardens it by dipping the end of the tool suddenly into cold water.

TEMPERING AND HARDENING METALS.

The art of properly hardening tool-steel is a trade secret which many who obtain their livelihood by it are very reticent in speaking about. Steel edge-tool hardening is a matter of study and practice which, when acquired, secures the highest remuneration and steadiness of employment. An expert in this craft replied thus to an inquiry: "A good steel edge-tool hardener knows his value. I have made the study of edge-tool steel hardening a special feature. I can harden and temper tool-steel, from a very fine drill upwards. My turning tools are made from old files, which are doing excellent work, through proper hardening and tempering. I put tools to-rights for many mechanics in my district."

"The art of steel-hardening properly does not consist of heating to cherry-red and plunging in the water bucket. I have received many offers in money from tool-makers for my secret in tool-steel hardening. I refuse to sell it," writes a second expert.

Another experienced master in this difficult "trick of the trade," J. Matthewson, gives the summary for tempering:

1. Good steel.
2. No over-heating.
3. Cutting out all cracked pieces.
4. Avoidance of final blows edgewise of the tools when getting rather cold.
5. Clean water with all frosty chill removed.
6. Do not "plunge" too hot.

The above directions are given by one who claims to have tempered thousands of tools, but a novice undertaking to temper tools by it for a shopful of workmen would soon be replaced by another who had no rule to go by, but could temper, having learned by experience, the tools brought to him as they were needed in the shop.

H. Woodruffe kindly informs the inquiring student, "Try the following way of tempering tools; heat the tools to a dull redness, then plunge them two or three times into a mixture made by dissolving 10 parts by weight of rosin in 5

TEMPERING AND HARDENING METALS.

parts of fish oil; stirring in $2\frac{1}{2}$ parts of melted tallow. The tools are then reheated to dull redness and plunged into cold water.

In answer to an inquiry "How can I harden cast steel so that it will hold an edge and not crumble?" the able editor of the *American Machinist* replies: "The method of procedure would depend on the kind of steel and the purpose for which it is to be used. For ordinary lathe and planer tools, heat the tools in a charcoal fire to a cherry red, and quench them in a hardening solution consisting of one gallon of soft water and one-half pint of salt."

There are two classes of steel: *Hard* steel, which contains over a half of one per cent. of carbon; this becomes hard when it is heated to redness and quenched in water.

Mild steel contains less than a half of one per cent. of carbon; this does not harden sensibly when so treated.

The two classes pass gradually one into the other, so that it is impossible to draw an exact line of separation.

Hard steel is almost always made by cementation, with or without subsequent melting. Mild steel is made either by the Bessemer or the Siemens process.

When steel is heated to redness and suddenly cooled, as by quenching in water, it becomes very hard, whilst if slowly cooled it becomes soft. After the steel has been hardened, the hardness can be reduced or the metal tempered by heating to a moderate temperature and cooling, the rate of cooling having little influence.

While the cause of hardening and tempering is not yet fully known, it is, however, intimately connected with changes in the condition in which the carbon exists in the metal. The hardness which can be imparted to steel depends on the

NOTE.—Cementation is a metallurgical process in which two substances are heated in contact to effect a chemical change in one of them.

TEMPERING AND HARDENING METALS.

amount of carbon present, and on the rate at which the temperature falls over the critical point. Three cooling agents are used—mercury, which is the most rapid; then water, which is almost always used in practice, and lastly oil.

Saws are hardened in oil, or in a mixture of oil with suet, wax, etc. They are then heated over a fire till the grease inflames. This is called being “blazed.” After blazing the saw is flattened while warm, and then ground. Springs are treated in somewhat the same manner, and small tools after being hardened in water are cooled with tallow, heated till the tallow begins to smoke, and then quenched in cold tallow.

Carbon exists in steel in two forms:

(1.) In *soft steel* it is present in the form of a definite compound, scattered through the metal. In this form it is called carbide carbon.

(2.) In *hardened steel* it is present apparently in combination with, or in solution in, the whole of the iron. In this form it is called hardening carbon.

Hardened steel is usually too brittle for use, and must, therefore, have its hardness let down by tempering; the higher the temperature of tempering the more will the hardness be reduced. For articles which are required to take a very keen edge the hardness must be very little reduced. In all cases, of course, a suitable steel must be used.

NOTE.—When the steel is heated to redness the carbon passes into the condition of hardening carbon, which is the stable form at high temperatures, and on slow cooling, as the temperature reaches about 1,500° F., it passes into the carbide condition, the stable form at low temperatures, and if the cooling be slow enough the whole may change its form. The passage from the one form to the other takes time, and if the metal be suddenly cooled over the critical temperature the carbon cannot change its condition before the metal is too solid to allow of further molecular change, and the metal remains hard. The carbon in the hardening condition is at ordinary temperatures in a state of stress, and when the metal is heated so as to allow molecular freedom, some of it will pass into the carbide condition, and the steel will be softened to some extent, the amount of softening depending on the temperature to which the metal is heated.

GRADES OF TOOL-STEEL.

The grades of hard steel made are:

RAZOR TEMPER.—Contains one and a half per cent. of carbon. This steel becomes very hard, and is very difficult to work. Articles made of it take a very keen edge.

SAW FILE TEMPER.—Contains one and three-eighths per cent. carbon. This steel hardens well, and tools made of it take a very keen edge. It is easier to work than the razor temper, and with care can be welded.

TOOL TEMPER.—Contains one and a quarter per cent. carbon. This steel does not become so hard as those above, but is hard enough to take a keen edge. It is easier to work and can be welded with care.

SPINDLE TEMPER.—Contains one and one-eighth per cent. carbon; this is a very useful steel for large tools, but requires care in welding.

CHISEL STEEL.—Contains one per cent. carbon. This is a very useful steel. It hardens well, though it becomes less hard than the steels containing more carbon, and when hardened is very tough. It is used for cold chisels and other tools which require strength and a moderately sharp cutting edge.

COLD-SET TEMPER.—Seven-eighths of one per cent. carbon. This is a very tough steel, but does not harden well. It is used for cold sets and other tools which have to stand heavy blows. It welds fairly well.

CASE-HARDENING.

Case-hardening is a process by which the surface of wrought iron is turned into steel, so that a hard exterior, to resist wear, is combined with the toughness of the iron in the interior. This is effected by placing the article to be case-

NOTE.—A more rapid method of case-hardening is conducted as follows: The article to be case-hardened is polished, raised to a red heat, sprinkled with finely powdered prussiate of potash. When this has become decomposed and has disappeared, the metal is plunged into cold water and quenched. The case-hardening in this way may be made local by a partial application of the prussiate.

CASE-HARDENING.

hardened in an iron box full of bone-dust or some other animal matter, and subjecting it to a red heat for a period varying from one-half hour to eight hours, according to the depth of steel required.

The iron at the surface combines with a proportion of carbon, and is turned into steel to the depth of $\frac{1}{8}$ to $\frac{3}{8}$ inches. The principal materials used in effecting the hardening are: granulated raw bone, hydro-carbonated bone black, black oxide of magnesia, sal soda, charcoal, and salt. These materials are commonly used and give much satisfaction if they be carefully and properly handled.

The work which is to be hardened can be packed in cast or wrought-iron boxes, sealing with fire-clay or mud, so as to prevent the gases from escaping as much as possible. The pieces to be hardened should be placed about two inches apart in the box. The vacant spaces are well filled and packed with the material used for the case-hardening purpose. Should the box be supplied with heavy work, as crank-pins, guides, etc., fifteen to twenty hours of steady heat are necessary in order to secure the best results. If, on the other hand, you have light pieces, as link blocks and pins, eight to ten hours will be sufficient to subject them to a good heat.

The work may be placed in the furnace about 8 o'clock in the morning and heated all day. At night close up the furnace, letting the box remain over night; if the surface of the article is to be hardened all over, it is quenched in cold water upon removal from the furnace. If parts are to remain malleable it is allowed to cool down, the steeled surface of those parts is removed, and the whole is then reheated and quenched, by which the portions on which the steel remains are hardened.

Malleable castings are sometimes case-hardened in order that they may take a polish; malleable iron may be case-hardened by heating it red-hot, rubbing cyanide of potassium over it, or by immersing it in melted cyanide, again heating and quenching in water.

TEMPERING SCALE.

The temperature to which the steel is heated for tempering is usually judged by the color of the oxide.

Heated steel becomes covered with a very thin film of oxidation, which grows thicker and changes in its color as the temperature rises; this color is an indication of the temperature of the steel on which it appears.

Oxide Tint.	Temp. Fah.	
	Deg.	
1. Pale yellow.....	428	} Very small tools requiring the keenest cutting edge.
2. Straw yellow.....	446	
3. Golden yellow....	469	Hammers, taps, reamers, etc.
4. Brown.....	491	Cold chisels, shears, etc.
5. Brown, with purple spots.....	} 509	Axes, planes, etc.
6. Purple.....		
7. Bright blue.....	550	Watch springs, etc.
8. Full blue.....	559	Fine saws, augers, etc.
9. Dark blue.....	600	Hand and pit saws, etc.

The above table shows the temperature at which the steel should be suddenly cooled in order to produce the hardness required for different descriptions of tools. It also shows the colors which indicate that the required temperature has been reached.

ANNEALING.

This is the art or process of removing the brittleness of steel, and at the same time retaining its toughness and elasticity. In general, these results are obtained by heating to a high temperature and then cooling very gradually.

BENCHMAN'S TOOLS.

The most elementary division into which mechanical devices and appliances can be resolved are two:

1. Hand-tools.
2. Machine-tools.

The first includes those which are or can be utilized without any force other than manual labor. The second division embraces all new as well as old machines, designed to be employed in combination with the various original powers, such as are derived from steam, water and other sources of energy, helpful to mankind.

While no day now passes without adding to the already great number of useful and more or less complicated machines, it is true that long before human history began, hand-tools such as are described and illustrated in the few following pages were in wide and constant use. It is true, also, that skill in manipulating the latter will always take first rank as compared to the former; fortunate the workman who has a chest full of the highest quality of hand-tools such as are described.

WORK BENCHES.

A machinist's bench is the most "homelike spot" in the shop. The "vise-man" has usually this coveted place with its appropriate tools and drawer, to which he has the exclusive key; the lathe-hand generally owns his own "box," which is usually placed under or at the foot of his lathe, or otherwise he may use a tray or stand.

Fig. 115 shows a bench two feet ten inches in height and two feet three inches in breadth, with drawer.

Benches are usually constructed in longer or shorter lines, with the best light obtainable, to aid in seeing the work. A

WORK BENCHES.

wise and a drawer are put about every ten to twelve feet, according to the work, large work requiring the greater space for ease of execution.

The qualities to be desired in a work bench are stability, hence extra thickness in outer plank, as shown, supported by

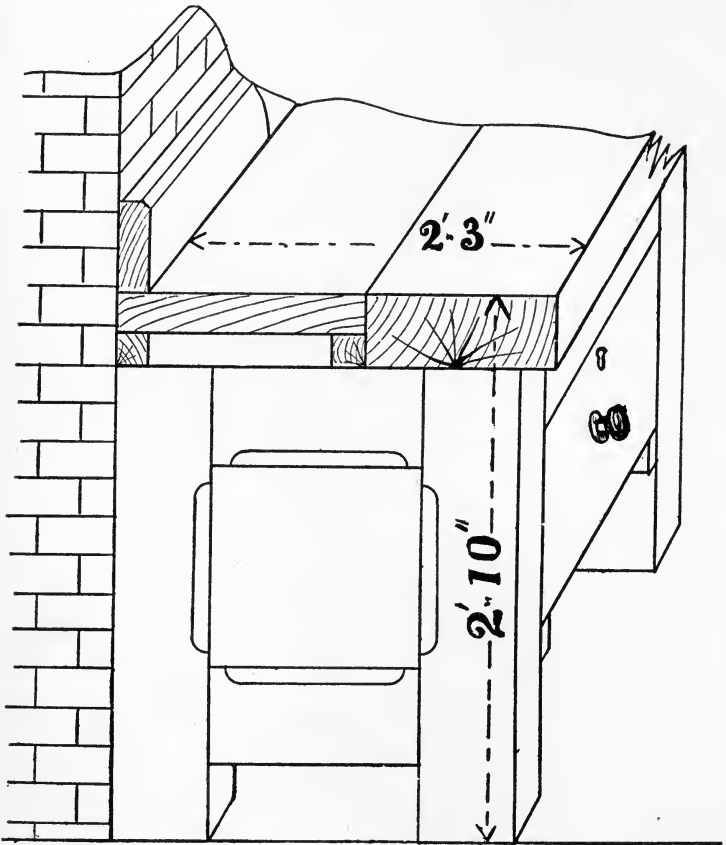

Fig. 115.

substantial wood or cast-iron legs, suitably arranged according to each shop's requirement. A well-built drawer of sufficient size to accommodate the workman's hammers, chisels, etc., without crowding. The drawer fitted with a large slid-

WORK BENCHES.

ing shelf, to separate the files and lighter instruments from the heavier tools. An improved work bench is shown in fig. 114, designed for both iron and wood work; construction drawings and castings for this are furnished by Messrs. Brown & Sharp, Providence, R. I., to whom credit is due for the following description:

The leg or casting *a* consists of a rigid standard, a bracket for the support of the shelf *c*, and its accompanying back. The legs or standards are fastened to the floor by coach screws, shown at *l*, and are supported at the back by the wall *BB*. They are usually placed about 4 feet apart, and support the bench *b*, the shelf *g*, the frame-work *n*, and the shelf *c*, and its accompanying back. The frame-work *n n*, forms a strong support upon which slide the drawers. The shelf *c*, supported by the brackets is held in place by the cast-iron clip, shown at the front. The shelf *g*, affords a neat and substantial support for the gas brackets. The front of the leg or standard is provided, when desired, with a hole to receive the bolt for holding the vise, and this construction brings the vise directly over the leg or standard.

NOTE.—“I am studying about what kind of benches to put into the new North shop. I am sick of the usual things; they are too convenient to throw things under, for one thing, and I have about made up my mind to have them wain-scoted, or sealed up, letting the bottom of the ‘sealing’ drop back, say eight inches.

“I am prejudiced against drawers in benches. Our men will pile files in them, and do the files more damage than their regular use. Then they will throw in chipping chisels, and hammers and wrenches, and squares, and scrap iron, and scrap brass, and odd pipe fittings, and sheet rubber, and I don’t know what all. I am studying on a wall cupboard to take the place of the drawers, and if I succeed in getting up anything to suit my ideas of the proper thing, you shall hear of it.

“I mentioned my objections to drawers to Mr. Viall, the superintendent, and he got the keys from the men and we made the grand rounds. Yale locks to start on—think of that, you who use padlocks!—and drawers that you could actually draw right open without any hammering or fussing.

“And when those drawers are opened, they looked as nice and clean inside as any apprentice’s tool box. Here a neat, clean, sliding tray for scales and calipers, and small tools generally; here a division for chisels, and here another one for files.”—CHORDAL, in *American Machinist*.

THE VISE.

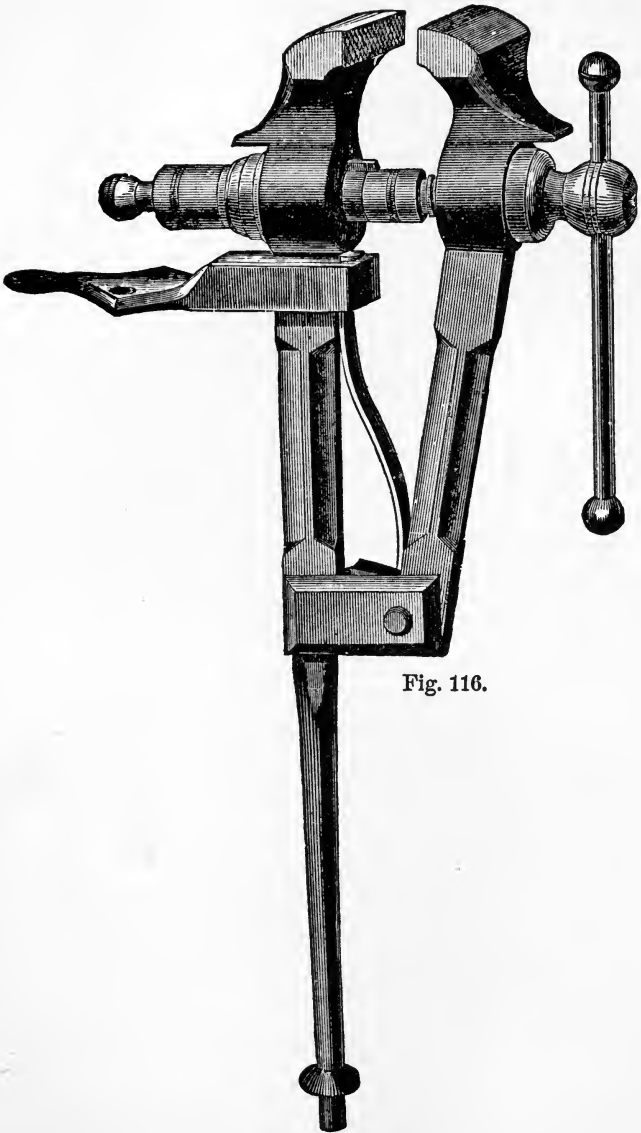

Fig. 116.

THE VISE.

The name of this well-known device is derived from the French, *vis*, a screw; hence the screw portion is its most important part.

The *vise* is a gripping or holding tool or appliance, fixed or portable, used to hold an object firmly in position while work is being performed upon it. The vise is closely allied to the *clamp*; both have movable jaws that may be brought together to hold any object placed in position between the jaws.

Vises are made in two parts forming jaws either joined by a spring, or arranged to move upon slides or guides. Fig. 116 is an example of the first, and fig. 117 of the second form.

The large engraving shows the common form of bench vises. This consists of a fixed vertical leg pivoted between arms or plates secured some distance down on the fixed leg shown. The jaws of the device are held apart by a spring, and brought together by a screw, which is passed through or into a box-nut in the fixed leg. The jaws of this vise are parallel bench-wise. The shop term for these is "solid box wrought-iron leg vises," which expresses their main characteristics, as they are usually made of wrought-iron. The jaws are faced with steel cut with grooves, to allow a firm "grip," and afterwards tempered.

The jaws of a vise are moved by various methods—by screws, levers, toggles, or ratchet and pawls, one jaw being usually fixed firmly to the bench or other support to which the vise is attached; some forms are made adjustable at any angle; others have parallel motions and are provided with swivels to adjust the jaws to the shape of the objects to be held by them.

THE VISE.

This device receives several names derived from the use to which it assigned, thus: bench-vise, saw-vise, parallel-vise, pipe-vise; an illustration of the latter is shown elsewhere in this volume.

THE HAMMER.

The *hammer* was probably the first tool used by mankind; hammers of stone are found among the remains of antiquity, and they are still common among barbarous races. The

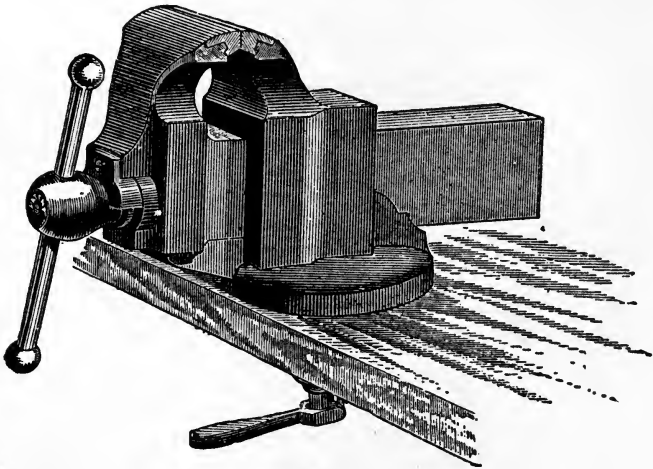

Fig. 117.

hammer, in common every-day service is an instrument, or tool, consisting of a solid head, usually of metal but sometimes of wood or prepared leather, set cross-wise to the handle. The machinist's hammer, as generally used, weighs from one to two and one-quarter pounds, exclusive of the handle.

The *peen* of a hammer is the opposite end to the head, which terminates in a rounded or cone-shaped point.

NOTE.—“The Century Dictionary spells it peen, but gives also four alternative spellings, pean, pene, pein and piend, either of which may be assumed to be permissible. The word may originally have been pin, which was sometimes used for a peak or pinnacle, which the peen of a hammer often is.”

THE HAMMER.

The *eye* of the hammer is the center opening through which the handle is inserted. The eye is left soft as to temper, as it will in that condition better resist the shock of the blows; the hammer is made of high-grade steel, carefully tempered on head and peen; the head is usually made cylindrical with flat face.

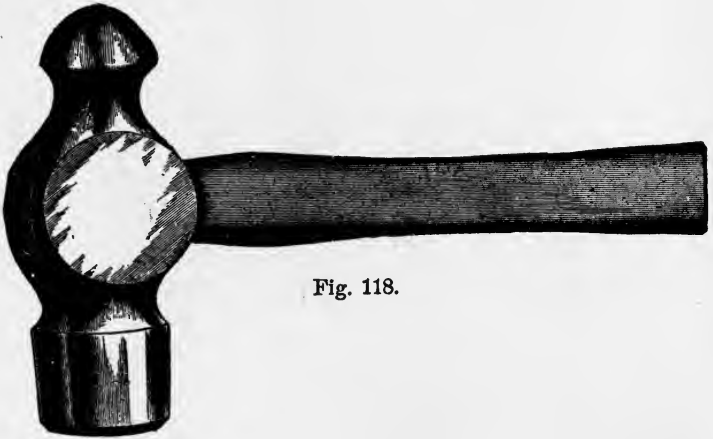

Fig. 118.

Copper hammers are also in use, the body being of malleable iron, and the ends or tips are of pure bar copper; these are driven into cavities provided with a slight taper, or inserted in parallel recesses and fixed with set screws, which permits the tip being rotated as the edge at one side wears away on account of the soft material used.

Timber mallets are used on sheet iron, as the blow covers a large surface and does not leave a recess, which would be the case if struck by a steel hammer. A decided improvement on the timber mallet is the hide-faced hammer; the raw-hide mallet has a core or strip of soft metal in the center, round which is rolled or compressed the raw-hide, making a weighty and yet not bulky implement.

THE HAMMER.



Fig. 119.



Fig. 120.



Fig. 121.

THE HAMMER.

The "lead hammer" is used to avoid "upsetting" of machine parts needing to be hammered, and too finely finished to be roughly treated; the heavy wooden mallet has been, in shop work, superseded by the soft ended lead, brass or leather hammer.

The hammer is made in such a variety of forms that it is almost impossible to classify it; it is called not only after the use to which it is put, but after the trade-class which uses it, as the machinist-hammer, the blacksmith-hammer, etc.

Hammers are principally named from the end opposite the face of the hammer; this is called the peen; the claw-hammer gets its name from the peen end, etc.

A *ball-peen hammer* is shown in fig. 118.

In its use the hammer should be grasped near the end of the handle, giving it a free arm swing, and carrying the head through a nearly vertical plane. If the plane of the swing approaches a horizontal the weight of the hammer will produce a twisting effort on the fore-arm, which will be very wearing. The handle should be grasped with only sufficient force to safely control the blow.

On the previous page are shown three hammers: fig. 119 is a straight-peen, fig. 120 is a ball-peen, and fig. 121 a cross-peen, hammer. These are the three principal tools used for general service.

The face of the hammer should be kept true and smooth, by careful grinding and polishing.

SCRIBERS.

A *scriber* or marker, of which two forms are shown in figs. 122 and 123, is a rather important tool in machine and engineering practice, as it is used to assure the close fitting of one piece or part of the work to the other part.

The scriber, fig. 123, is used upon inside work, and the other, fig. 122, for surface work.

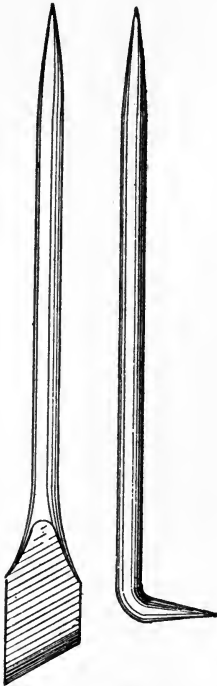

Fig. 122. Fig. 123.

KEY-SEAT RULE.

This is an instrument made in the form of angle iron and used in connection with the scriber in marking parallel lines on round shafts; such lines as are necessary in cutting key-seats.

THE STEEL SQUARE.

The *steel try-square* is an instrument used by machinists, draughtsmen and others for trying or describing right angles. It consists of two rules or branches, as shown in fig. 124, fastened perpendicularly at one end of their extremities, so as to form a right angle.

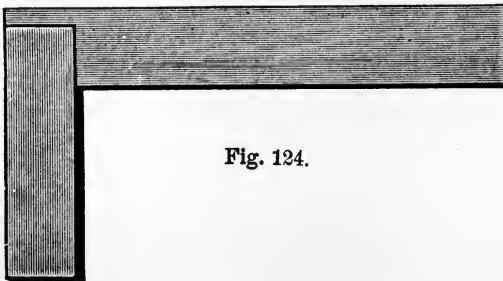

Fig. 124.

THE CHISEL.

This is a tool consisting of a blade, commonly flat, having a beveled or sloping cutting edge at one extremity, and a handle at the other, designed to cut under the impulse of a blow from a mallet or hammer or under *pressure*, as in a lathe.

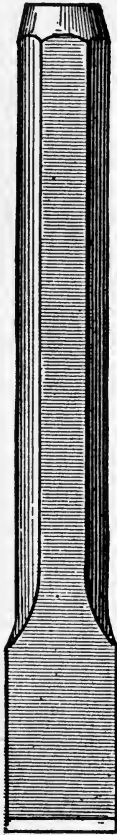

Fig. 125.



Fig. 126.

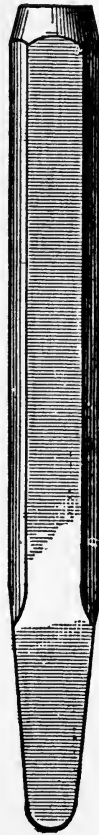

Fig. 127.

A *cold-chisel* is a chisel with a cutting edge formed entirely of steel, properly tempered for cutting metals.

THE COLD-CHISEL.

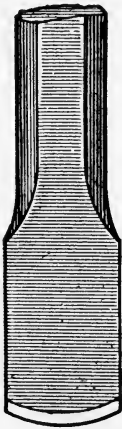

Fig. 128.

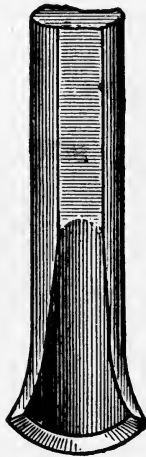

Fig. 129.



Fig. 130

In common hand use, the cold-chisel is a cutting tool principally used for "chipping" or cutting out metals; chisels are used as well for working in stone, wood and other materials, but in this volume relating to working in steel, iron and brass, all reference to the chisel, in any way, means its work in metals.

Fig. 125 represents the common flat cold-chisel.

A *cape-chisel* is shown in fig. 126; this chisel has clearance on the sides and is deep on edge view.

A *round-nose chisel* is shown in fig. 127.

A *curved cold-chisel* is shown in fig. 128.

The *cow-mouth chisel* is shown in fig. 129; this form of chisel is called a *gouging-chisel*.

The *diamond-point chisel* is shown in fig. 130.

FILES.

A *file* is a metal (usually steel) tool, having a round, triangular, rectangular or irregular section, and either tapering or of uniform width and thickness, covered on one or more of its surfaces with teeth or transverse or oblique ridges.

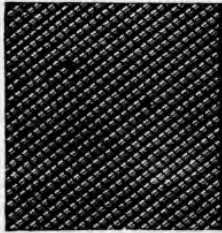

Fig. 131.



Fig. 132.



Fig. 133.



Fig. 134.



Fig. 135.

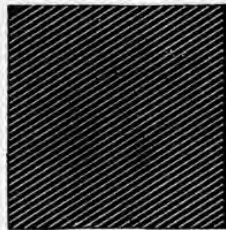

Fig. 136.

The *tag* end of a file is the point or taper part intended for attaching the file to the handle; it is the part left untempered.

The *shoulder* is the abutment where the tag meets the body of the file; the "point" of a file is the end opposite the handle.

A file is used for scraping off, reducing or smoothing metals, ivory, etc.; before the days of modern machinery,

FILES.

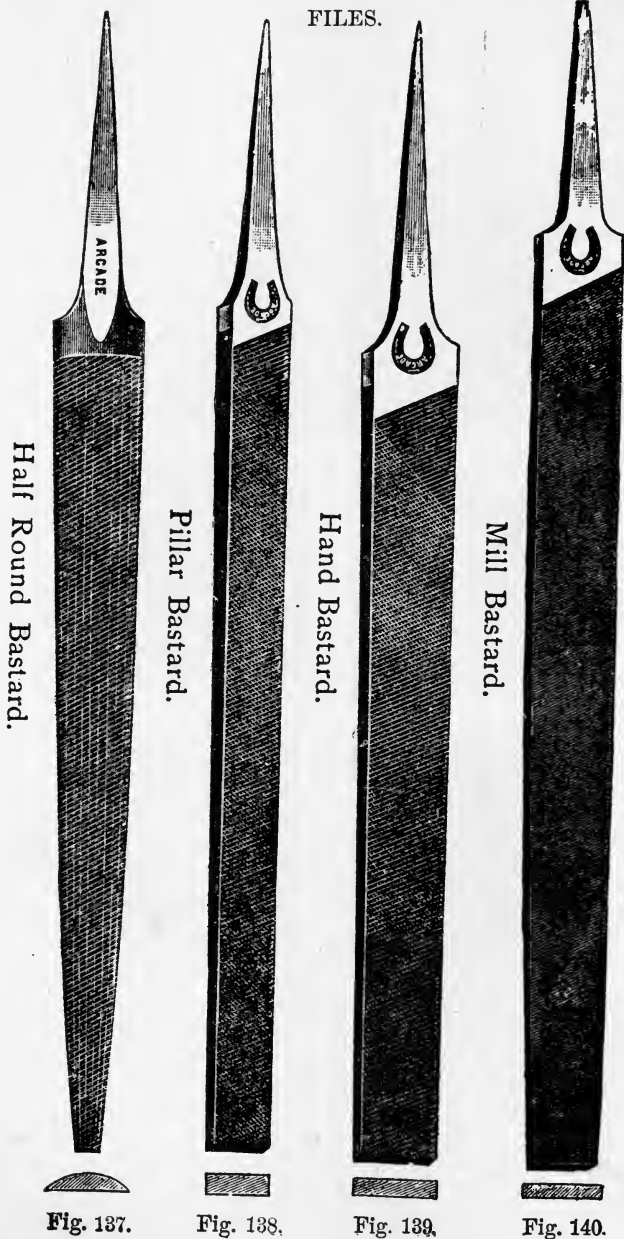

Half Round Bastard.

Pillar Bastard.

Hand Bastard.

Mill Bastard.

Fig. 137.

Fig. 138.

Fig. 139.

Fig. 140.

FILES.

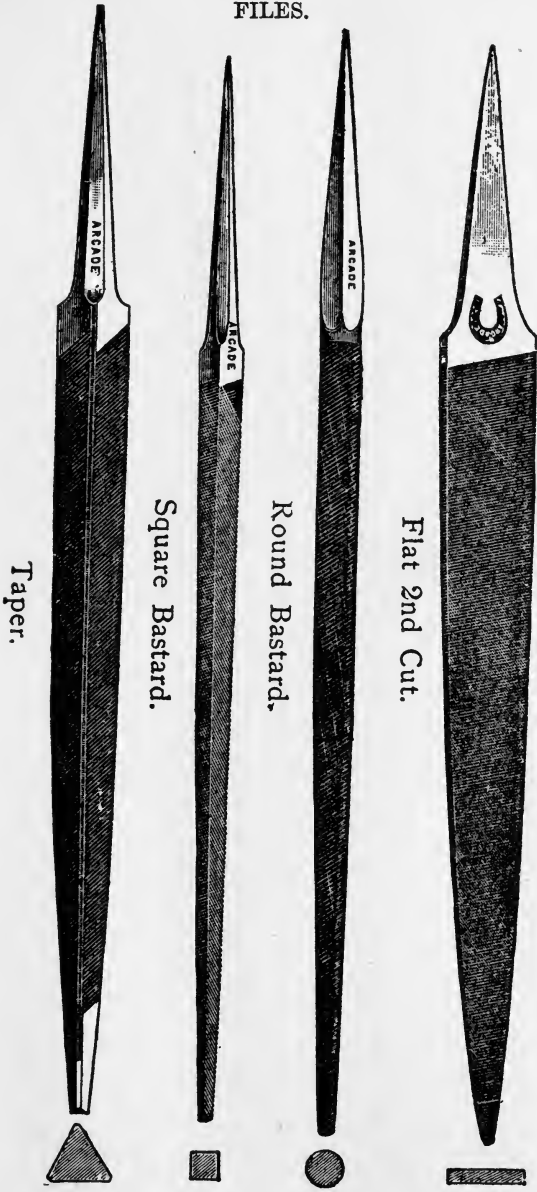

Taper.

Square Bastard.

Round Bastard.

Flat 2nd Cut.

Fig. 141.

Fig. 142.

Fig. 143.

Fig. 144.

FILES.

“chipping,” or “chiseling,” and “filing,” composed a large proportion of the mechanical work, and to-day it is difficult to think how work could be executed without the file and the chisel—perhaps it may not!

A very clear idea of the shape and section views of the most commonly used files are given in the following illustrations. The figs. from 131 to 136 represent the difference in the character or coarseness of the “cut” of the files, described hereafter. Fig. 131 is a coarse, double-cut surface. Fig. 132 is the “bastard” double-cut; fig. 133 is the “second double-cut” file; fig. 134 is the “smooth double-cut” file; fig. 135 is the “dead smooth double-cut” file, and fig. 136 is the “mill bastard,” a single-cut file.

These full-size representations are taken from twelve-inch files; the sixteen-inch file is coarser in proportion, and the shorter files are still finer in proportion.

It will be seen that there are single-cut and double-cut files in the above list; in the single-cut files the diagonals are parallel to one another; in the double-cut files the diagonals cross each other—all as shown in the illustrations.

Fig. 137 is a half-round bastard file, as shown in the sectional view at the bottom of the illustration. The same observation applies to all the representations of the files, *i. e.*, the sectional views are shown to more clearly explain the make of the instruments, or tools.

This is a combination of the flat and round file in one. It files curved work and angles better than the flat file.

The *pillar bastard* file is shown in fig. 138; this is also called a “slot” file or “cotter” file, it being parallel and generally used for these purposes.

FILES.

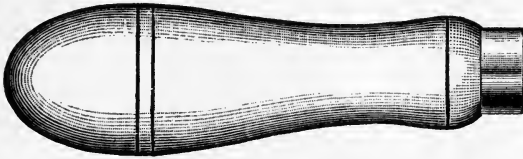

Fig. 145.

Fig. 139 represents the hand bastard file; this file is very similar to the flat bastard, but differs in this respect, the latter is taper in its breadth, the hand file being parallel.

The *mill bastard* is shown in fig. 140; this differs from the bastard file, in that the bastard is cross hatched, or cross cut; the mill file is plain diagonal cut only, one way in straight ridges, for use on hard steel saws and such like work.

Fig. 141 shows the "taper-file," called also the "three-square file"; this is used for filing out corners, etc.

The square bastard file is exhibited in fig. 142; this is used largely for squaring round holes after the drill; for enlarging mortises, or key ways, etc.

Fig. 143 shows the round bastard file; this file is in general use for shaping fillets or angles, finishing half-round ended slot holes, enlarging round holes, etc.

The flat "second-cut" file is shown in fig. 144; this is a file for general work and more particularly for lathe and extra fine finished surfaces.

Fig. 146 shows the file which is in general use by machinists, whether flat, round, or half-round, in cross section, *i. e.*, "bastard file"; its teeth are between coarse and second cut.



Flat Bastard.

Fig. 146.

FILES.

A *file handle* is represented in fig. 145; this is made of hard wood, having a ferrule or ring on its end outside of the hole provided for *tag* of file; the end for hand should not be pointed, but bluff, to take large surface of hand, as if small or pointed it may blister the hand.



Fig. 147.

Fig. 147 shows a *surface file holder*; this holder is used when the surface is broad and cannot be reached by an ordinary length of file on account of the handle; as will be seen the rod has provision on the end for the left hand to grasp the point of file with a downward pressure; the handle screws the rod tight against the shoulder and the point, and the center support forms a slight curve in the file, an advantage of considerable importance in filing plane surfaces.

A *scratch gauge* is shown in fig. 148; this gauge is made of round steel, graduated to parts of an inch; on this bar slides a bushing which can be clamped or fixed by the action of the fly nut; the "marker" is a square or circular piece of thin, tempered steel, which is firmly held against the end of the bar, usually by a set screw.

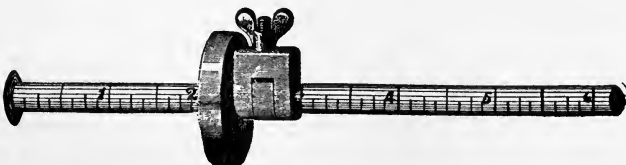

Fig. 148.

TWO-FOOT RULE.

Fig. 149 shows a *boxwood two-foot rule*; this is "four fold"; that is, the two feet comprise four pieces. The common rule is graduated into inches marked with numerals,

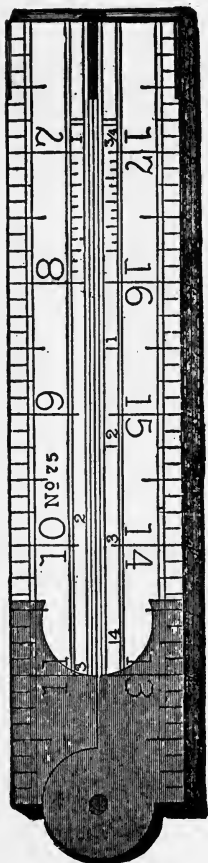

Fig. 149.



Fig. 150.

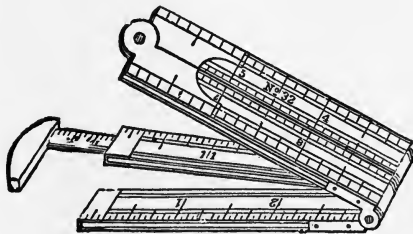

Fig. 151.

half inches marked by long lines between the inches; quarter of an inch marked shorter than the half inch, and one-eighth of an inch marked shorter than the quarter inch; again, one-

CALIPERS, ETC.

sixteenth is shorter than the one-eighth; these are the gradations on a common rule, and should be carefully learned by the student.

Special rules are marked as fine as the one-hundredth part of an inch; these are usually made of steel, as the wood will not stand close markings. The ends of common rules are tipped with brass to prevent wear, yet it is usual for the experienced workman to take his spacings or short measurements for greater accuracy with dividers from the inside graduations on the rule and not from the brass end.

The *two-fold rule* shown in fig. 150 is seldom used, on account of its unhandy length, being liable to fracture.

Fig. 151 shows a caliper rule, generally made one foot long, four fold; it is useful for rough measurements, but not sufficiently accurate on account of the joint in the fulcrum of the rule, which is liable to spring and wear from use.



Fig. 152.

Fig. 152 is a *steel straight-edge*. This is constantly used for marking, scribing, and as a telltale for hollow or curved work; it is also used with the aid of the rule to measure depth of holes, etc.

Outside calipers are shown in fig. 153; these are used for measuring diameters and outside dimensions of circular work; the essential portion for correct work is the rivet or connecting pin, which should be extra large, with a wide washer fitted with the utmost accuracy.

DIVIDERS AND PUNCH.

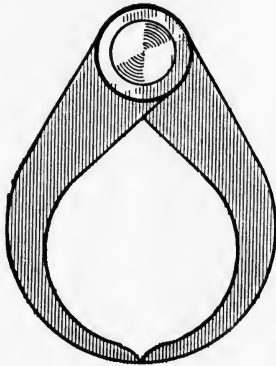

Fig. 153.

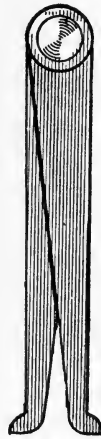

Fig. 154.

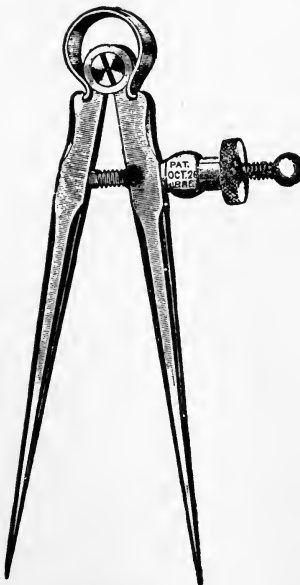

Fig. 155.



Fig. 156.

CENTER PUNCH, ETC.

Inside calipers are shown in fig. 154; these are used for ascertaining internal diameters and are useful instead of dividers for measuring the distance between lines and points.

The *spring dividers*, fig. 155, are used for setting out work, marking exact points and distances; great accuracy can be attained by the use of the screw movement, by which the instrument is adjusted.

Fig. 156 shows the well-known "center-punch"; this is made of steel with a hardened end, and is used for marking centers in lathe work, etc. The center-punch should always be formed to an angle of 60° ; a fine center-punch for making indelible lines after being scribed on surfaces, is called a prick or "bob" punch; this punch is in general use on template work after the scribe or scratch gauge has been used; there are many other forms of hand punches and markers used for transferring and special work.

The *monkey-wrench*, shown in fig. 157, is an adjustable tool, too well known to need description; its right name is "Moncky," as described in note below.

NOTE.—In his interesting article upon the genesis of machine design, Mr. W. H. Sargent spoke of the slide which moves up and down in the handle of a monkey wrench as resembling a toy monkey, and thereby drew an analogy. To this Mr. H. E. Madden writes: "The wrench is not named from this, neither is it so called because it is a handy thing to 'monkey' with. The right name is 'Moncky.' Charles Moncky, the inventor of it, sold his patent for \$2,000, and invested the money in a house in Williamsburg, Kings County, N. Y., where he afterward lived."

WRENCHES.

The *Stillson wrench*, shown in fig. 158, is an improvement on the monkey wrench; the pressure on the handle or lever

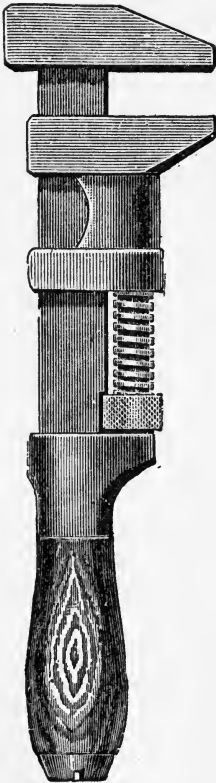

Fig. 157.



Fig. 158.

tends to close the holding jaws together; for this reason it is sometimes called a pipe wrench, because it will grip a pipe, or round surface, which the monkey wrench will not.

SLEDGE AND ANVIL.

Fig. 159 shows a *striking hammer* or light sledge, handy in every shop.



Fig. 159.

Fig. 160 exhibits an *anvil*, one of which, although a blacksmith tool, is generally found most useful in the machine shop.

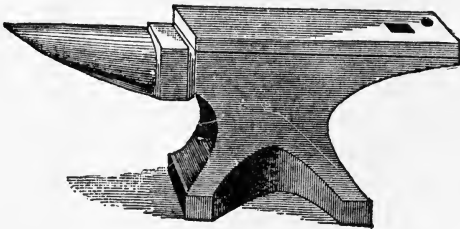

Fig. 160.

WISE AND BENCH PRACTICE.

Vise or bench-work include all operations performed by the machinist that are not included in the work performed by machine tools.

Again, in a general way vise work may be sub-divided into two branches, viz., Fitting and Erecting; fitting requires more skill than does boring, turning, or, as the operation of machine tools is termed, machining.

The work of "fitting" embraces the preliminary operations necessary to be done before that properly allotted to the machine tool, and the machinist doing it is called a "fitter."

Erecting is the final operation; it is the combining of these pieces in their relative and proper positions one to the other, the result being an engine or machine; it is apparent that the operation of erecting must include greater skill and experience than fitting, hence the term "Erecter," denoting a superior "fitter."

USE OF THE VISE.

The advantages aimed at in the selection of a vise are:

1. Quickness in operation, especially in fastening and releasing the objects requiring work to be executed upon them.
2. Firmness in the grip or hold.
3. Steadiness in resisting strains or blows.
4. Strength to allow chipping or filing the work without the possibility of the vise breaking.
5. The jaws should move parallel and freely, and should be arranged so as to get the full power of the screw.

USE OF THE VISE.

Improvements in the vise, for particular purposes, have been invented, such as swivel jaws, ratchet, eccentric and wedge grip motion, etc., but the plain screw-vises shown in fig. 116 and fig. 117 are the most extensively employed.

In manipulating the vise the right hand is generally used to operate the lever, the left hand at the same time adjusting the work in the position required; when the work is well gripped in the jaws the left hand is disengaged from the object and a sudden strong strain, with both hands, is applied to the lever of the vise, thus assuring the firmest possible hold to be obtained.

In releasing the object from the jaws of the vise, the reverse order is followed; the two-hand strain is first employed, the right hand giving the final turns to the lever, while the left hand supports and guides the object about to be freed from the grip of the vise.

Vise-caps or *jaw protectors* are designed to save the steel jaws of the vise while subject to the action of the file; at the same time the caps act also as a soft medium between the hard, serrated face of the jaws of the vise and the finished portions of the work held.

Vise attachments are contrivances applied to parallel vises to adapt them to special varieties of work; pipe-holding attachments are an example, and there are many more.

THE USE OF THE HAMMER.

The *hammer* in an expert's hand is practically a part of himself; it is sensitive, and communicates intuitively to him by "the feel" and sound, the different conditions it is acting against, and the mechanical effect its blows accomplish.

The hammer, as a simple contrivance, used to drive, stretch or straighten, is the most important tool used in vise and bench work; it enters as well into almost all kinds of mechanical manipulations. Great skill and judgment are required to become properly expert in its use.

USE OF THE HAMMER.

The extreme difference often noted between workmen from artist to artisan depends upon the judgment shown in the velocity and energy of the blow delivered by the hammer.

A good hammer is one that has a long hole to provide a good bearing for the handle, and which has the metal round the hole tapered or curved with punching and drifting, called bell-mouthed; the hole itself should be an oval; the handle hole of a hammer being tapered at both ends, the shaft end in the metal is made to resemble a rivet which is thickest at the two ends; one end is fitted by paring the wood, and the other end by spreading the wood with wedges.

The wood of the shaft is preferably ash, and should be fitted when dry, the overlength outside being cut off and the wedges of iron driven in, causing the wood to fill the hole.

In using a hammer it is essential to study the difference in effect between a sharp blow with a light hammer, and a slow blow with a heavy one; the former penetrates farthest and gives least lateral pressure, while the latter penetrates less and spreads more outwardly.

The machinist's hammer is made heavier at the face than at the peen end, so that the hammer will naturally assume a position in the hand with the face downwards, this being the position generally required, the peen end only being used for riveting or for straightening or expanding.

NOTE.—The length of time a hammer remains in contact with the material it strikes is called "the duration of the blow." The duration depends on, one, the velocity of the impact; two, the weight of the hammer, and three, the hardness of the material operated on.

Thus within certain limits, 1, the duration of the blow is decreased, with increased velocity; 2, the duration of the blow increases with the weight of the hammer; 3, the duration of the blow increases with the less hard material; in other words, *the greater the rebound*, the shorter the duration of the blow, and when the energy of the blow is expended in bruising or permanently altering the form *the contact is prolonged*.

USE OF THE HAMMER.

The length of handle for heavy chipping should be thirteen inches, and the weight of the hammer with this length of shaft is one and three-quarter pounds.

When *chipping*, the handle is held at its end in the right hand, grasped firmly by the thumb and second and third fingers, the other fingers being lightly closed about it. This mode of holding the hammer distributes the strain and jar without tiring the hand. In striking one should stand well away from the vise, swinging the hammer back nearly vertically over the shoulder before each blow.

All hammers for hand use should be made entirely of steel; the practice of welding steel faces to an iron body, in order to avoid using all steel, produces an inferior tool; a soft, fibrous steel that will bear handling is preferable.

PROPER METHOD OF USING FILES.

The most important point to be decided before commencing filing is the fixing the vise to the correct height and perfectly square, so that when the work to be operated on is placed in the vise it will lie level. As to what is really the correct height some difference of opinion exists, but the height which is generally thought right is such that the "chops" or jaws of the vise come just below the elbow of the workman when he is at his place in front of the vise; it will be found that the average height of the elbow is from forty to forty-four inches, therefore forty-two inches may be the average. But

NOTE.—The handle of a machinist's hammer should be of straight-grained dry ash or hickory, twelve to sixteen inches long, depending on the weight of the hammer. The handle should not be too stiff in the shank, as too rigid a connection between hammer and hand causes undue shock; it should be so set in the eye that its length is at right angles to the axis of hammer head, and its long cross section parallel with this axis. The eye should be enlarged slightly at each end, as the handle can then be fitted in from one side and wedged to fill the enlargement of the eye on the other side. Hard, smooth wedges are not suitable for this purpose, as they jar loose too easily—soft wood or roughed metal wedges serve the purpose well.

USING FILES.

there is large economy in making the height of the vise suit each workman by raising or lowering the vise, or by the use of a platform; this enables the workman to get the full, free swing of his arms from the shoulder.

If the work to be filed is small and fragile, a movement of the arms, or of one arm alone being required, the vise should be higher, so that the workman may stand more erect and can more easily scrutinize his work. Should the stock to be filed be heavy and solid, needing great muscular effort, its surface should be beneath the level of the elbow joint and the operator should stand farther from it, with his feet from ten to thirty inches apart, one being in advance of the other, with the knees slightly bent, which will lower his stature, at the same time throwing his weight upon the file, causing it to penetrate the stock with but a slight movement of the arms, depending largely on the movement of the body to shove the file.

When filing, the operator should stand with the left foot about six inches to the left of the vise leg, and about six inches away from the bench; the right foot being thirty inches away from the vise leg or bench and in a straight line—at right angles to it. This position gives command over the tool, and is at once characteristic of a good workman.

The art of filing a flat surface is not to be learned without considerable effort, and long and attentive practice is necessary ere the novice will be able to creditably accomplish one of the most difficult operations which fall to every-day work, and one which even the most professionally taught workman does not always succeed in.

The file must be used with long, slow and steady strokes, taken right from point to tang, moderate pressure being brought to bear during the forward stroke; but the file must be relieved of all pressure during the return stroke, otherwise the teeth will be liable to be broken off, just in the same manner that the point of a turning tool would be broken if the lathe were turned the wrong way.

USE OF FILES.

It is not necessary to lift the file altogether off the work, but it should only have its bare weight pressing during the back stroke. One of the chief difficulties in filing flat is that the arms have a tendency to move in arcs from the joints, but this will be conquered by practice. A piece of work which has been filed up properly will present a flat, even surface, with the file marks running in straight parallel lines from side to side; each stroke of the file will have been made to obtain a like end.

There is beauty in well-finished work, perfectly square and smooth, as left by the file, untouched by any polishing materials; in such work the filing must be got gradually smoother by using progressively files of finer cut, and, when the work is deemed sufficiently finished for the purpose, the lines should be carefully equalized by "draw-filing," that is, the file is held in both hands, in a manner similar to a spokeshave, and drawn over the work in the same way, producing a series of fine parallel lines.

When it is necessary to file up a small surface—say 2 in. or 3 in. square—the file must be applied in continually changing directions, not always at right angles to the jaws of the vise.

When the surface is fairly flat, the file should be applied diagonally both ways; thus any hollow or high places otherwise unobservable will be at once seen, without the aid of straight-edges, etc. This method of crossing the file cuts from corner to corner is recommended in all cases, and the file should invariably travel right across the work, using the whole length of the file.

The file must be held firmly, yet not so rigid that the operator cannot *feel* the work as it progresses; the sense of touch is brought into use to a far greater extent than would be imagined, and a firm grasp of the tool, at the same time preserving a light touch to feel the work, is an essential attribute of a good filer.

In filing out mouldings and grooves which have sections resembling, more or less, parts of a circle, a special mode of handling the file becomes requisite. The files used are generally half-rounds, and these are not used with the straightforward stroke so necessary in wielding the ordinary hand-files, but a partial rotary motion—a sort of twist axially—is given to the file at each stroke, and this screw-like tendency, given alternately from right to left, and *vice versa*, serves to cross the file cuts and regulate the truth of the hollow.

To sharpen or cut the file it is advisable to hold it in an acid bath, consisting of seven parts of water, three parts sulphuric acid and one part nitric acid, after which a clear water and milk-of-lime bath cleans it. Then brush the file with a mixture of olive oil and turpentine, and afterward dry it with fine pulverized coke.

To clean used files it is recommended to hold them for a minute in a steam current with a pressure of 40 pounds per square inch, when the file is said to be absolutely clean.

When files have become clogged up with oil and grease, another plan is to boil them for a few minutes in strong soda water; this will dissolve the grease and, as a rule, set most of the dirt and filings free; a little scrubbing with an old brush will be beneficial before rinsing the files in boiling water and drying them before the fire. These methods will prove effective in removing the ordinary accumulation of dirt, etc., but those “pins” which are so much to be dreaded in files, when finishing work, can only be removed by being picked out with a scriber point, or, what is better, a piece of thin, very hard, sheet brass, by means of which they can be pushed out very easily.

NOTE.—With regard to cleaning tools which have become clogged up with minute particles of metal, the following directions will enable one to keep them in proper order. The most generally used tool for cleaning files is the scratch brush; but this is not very efficient in removing those little pieces which get firmly embedded and play havoc with the work. File cards are also used; they are made by fixing a quantity of cards—such as a pack of playing cards—together by riveting, or screwing to a piece of wood. These file cards are used in the same way as the scratch brushes, *i. e.*, transversely across the file in the direction of its “cuts.”

THE USE OF THE CHISEL.

The *chisel* in machine shop practice is essentially a hand tool; the accumulation of energy imparted to the blow of the hammer enables the sharp, tempered edge or end of the chisel to accomplish work much beyond that done by a push of the tool by hand power.

It is claimed that all machine work could be accomplished by a skillful workman by the sole use of the chisel and hammer. This cannot be said to-day, yet it is true of all exterior surfaces; the introduction of many machines is but the desire for economical production, and not because the hammer and cold-chisel cannot accomplish the work.

To acquire expertness in the use of the chisel is a matter of gradual development, the beginner only being allowed to do those parts of the "chipping" where the material runs no risk of loss, such as cutting sheet-iron, etc.; in other cases even special blocks of metal have been cast for apprentices to practice upon, for improvement, before being intrusted with any regular work. A study of the six figs., 125 to 130, is recommended in connection with the reading matter on page 182; in figs. 161 and 162 are shown the flat and cape chisels in actual practice, referred to hereafter.

Chisels are made of different widths, according to the material to be operated on; the broader the chisel the easier it is to hold its edge fair with the work surface, and cut smooth chips, and leave a more even surface; the usual breadth of a flat chisel, fig. 125, for iron and steel chipping, is seven-eighths of an inch.

Chisels vary in many particulars, but the hammer used is generally the same; if the same force of blow is applied to a narrow surface as to a wide one, it will cut differently; for instance, a narrower chisel can be used with a full blow on iron or steel than can be used on material like brass, which is more brittle; therefore to enable the workman to exert his full energy the chisel is made wide for the brittle material.

USE OF THE CHISEL.

The important point in practice with the chisel is the angle at which the cutting edge meets the stock; this varies according to the depth of cut and the nature of the material; the angle of the cutting end of a flat or cape chisel is usually about 60° , as shown in figs. 161 and 162; the angle of the long taper portion is about 6° in the flat chisel, fig. 161, and about 30° in the cape chisel, fig. 162.

The angle of these chisels, designed to work brass or gun metal, should be made a little less than for iron or steel, both in the taper part and the cutting edge.

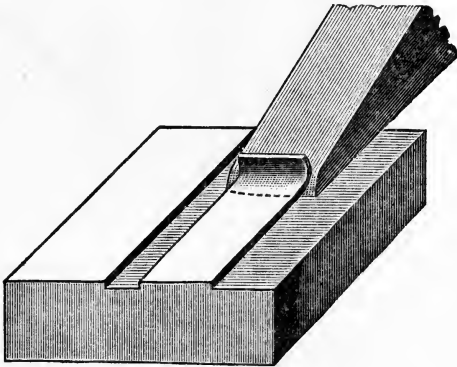

Fig. 161.

In practical use the chisel is not only held by the hand, but also is steadied by the "chip" in the work, as shown in figs. 161 and 162; the nearer the chisel is held by the hand to the head end the steadier it can be grasped when the hammer imparts the blow, and the chipped surface will be smoother.

In taking off a heavy chip one should stand well away from the vise, instead of close to it; in the one case the body is lithe and supple, having a slight motion in unison with the hammer, while in the other it is constrained and looks awkward. If, now, a light chip is to be taken, one may stand nearer to the work, so that he can watch the chisel's action and keep its depth of cut level. In both cases the chisel is

USE OF THE CHISEL.

to be pushed forward to its cut, and held as steadily as possible. It is a mistake to move it at each blow, because it cannot be so accurately maintained at the proper height. Light and quick blows are always necessary for the finishing cuts, whatever the kind of metal may be.

The use of a slightly curved cold-chisel is necessary when joining two planes, or when taking a very fine cut off a surface, as

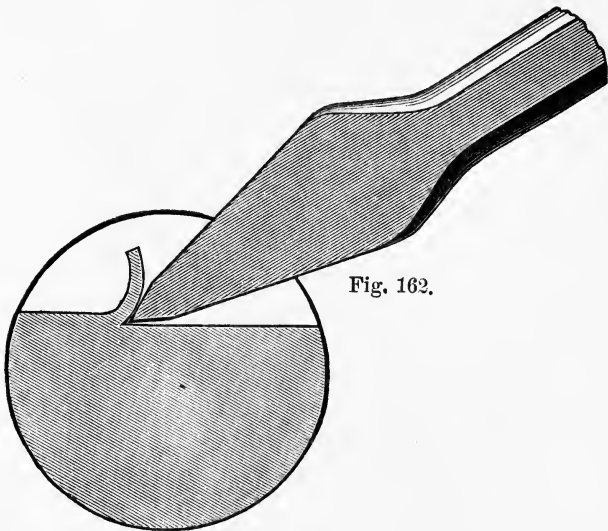

Fig. 162.

it will not show a ridge or groove, which the corners of a straight ground flat chisel would leave after it; a very slight rounding is enough, see fig. 161. A cow-mouthed chisel is necessary to chip bored holes, or the inside of hollow surfaces. For cutting out corners or the inside angles a diamond-point chisel is used, see fig. 130.

The *cape chisel* is used for cutting shafting, bars, etc., as shown in fig. 162. On account of its shape and great strength it is used in broad, heavy surface chipping, to cut grooves a little less distance apart than the flat chisel, which is then used to cut away the stock or ridge left between the

USE OF THE CHISEL.

grooves, as in fig. 161; should the flat chisel in heavy chipping be used on the solid surface without cutting these grooves, its corners are liable to break away. The point must be made as thin as possible, and, for ordinary purposes, it should be ground flat; grinding rounded, as fig. 128, is to be avoided.

Sharpening chisels ready for use is effected on ordinary grindstones, or an emery tool-grinder. For heavy chipping the point should be ground slightly convex, or curved, as shown in fig. 161, which is better than if ground straight, because the corners are relieved from duty, and are, therefore, less liable to break.

In any case the chisel should not be ground hollow in its length; in that case the corners will "inbed" or dig into the stock, and render it impossible either to guide the chisel or regulate the cut. The faces should be ground alike and square with the body of the chisel; if the faces are wider on one side than the other they will be inclined to "jump" sideways at each hammer-blow.

When the work is done by a round-nosed chisel it is called "fullering."

To be able to chip surfaces properly the chisel should be held firmly in the hand, the eyes fixed upon the *point*, not the *head*, of the tool, and the hammer held far down the handle, so that it may have a fair swing. One thing should be noted: Never chip towards an edge, but away from it.

A good fitter will always take off in this manner as much extraneous metal as he can, and only have recourse to the file to finish his work, for files are expensive, and soon worn out; while the chipping chisel is inexpensive, and easily repaired.

All fitters' work should be set out by the aid of the surface-plate, the scribing-block, the compasses and straight-edge. All lines should be delineated with small center punch-marks, which cannot easily be obliterated.

The *round-nose chisel* is used to finish fillets and cut oil grooves. See fig. 127.

SURFACING.

Surface plates, as shown in fig. 163, are made of fine-grained metal, of considerable weight and thickness; the portion machined and finished is cast "face down," so as to have a solid surface free of air or blow-holes; they are made with ribs or strengthening battens on the under side, to prevent any tendency to warp or spring; the face is planed, filed and scraped to a high degree of perfection, on account of the importance of the service they are intended to perform.

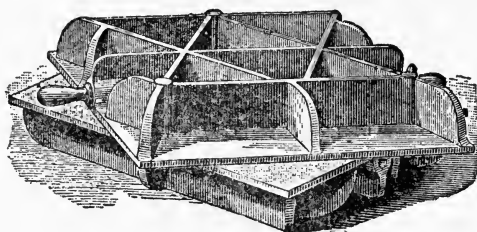

Fig. 163.

Surface plates are made three at one time for standards or originals; these are not applied to the usual run of work directly, but are kept to test the shop plates, so-called, and keep them accurate.

In shop practice in connection with the surface plates, a very fine coat of color, generally red lead mixed with oil, is applied to the plate by the use of a sponge or waste. The composition is then carefully rubbed off, leaving a slight trace on the plate, just sufficient to discolor the surface.

Next the hand should be passed over the surface, first of the plate, and next over the surface of the work to be "trued up"; this is done to make sure that no grit or foreign substance remains attached to either surface, as such would cause false markings and, consequently, imperfect execution of the work.

SURFACING.

When the work is very uneven the markings will be few and of small size; on these being "filed" down the work becomes more even and the markings extend in number and size; the file is finally discarded for the "scraper," which finishes the work, when the markings show all over the surface regularly and the surfacing is completed.



Fig. 164.



Fig. 165.

Scrapers are made of steel and of many shapes and forms; for interior circular work they are steel discs with a center rod; for corners they are shaped triangular; the most usual shape in every-day use are the flat surface scrapers, as shown above, i.e., the "straight" scraper and the "bent" scraper. These and all similar devices are used to give the finish to high-class surface work on steel, brass, etc., and for accurately fitting together the parts of machinery.



Fig. 166.

The file is used up to a certain state of accuracy; then the scraper comes into play and removes the markings of the surface plate, etc., making a smooth, fine surface, closing the grain of the material and giving it a fine polished appearance. A fine file would not give the same appearance, nor would it act on the exact spot as well as a scraper.

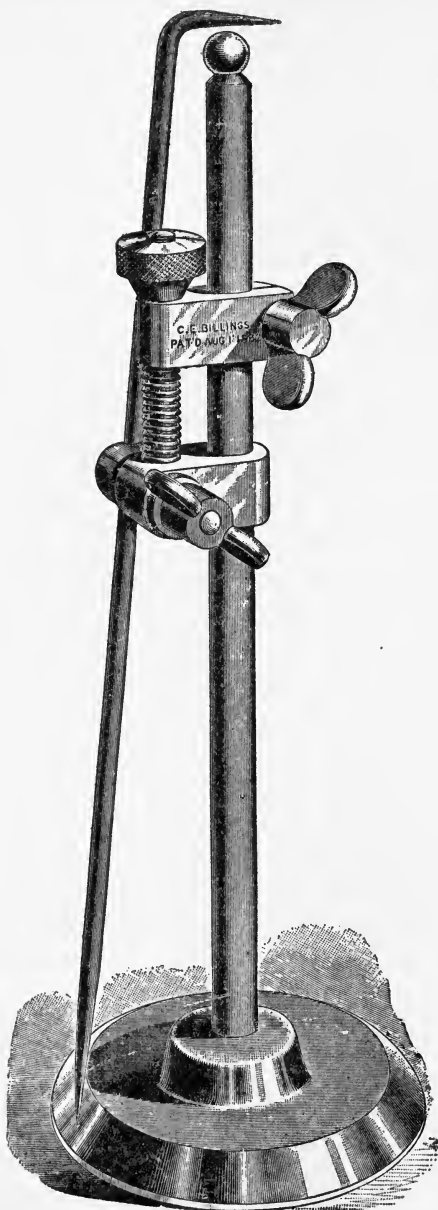

Fig. 167.

SURFACING.

The steel straight-edge shown in fig. 166 is an instrument in constant use to show the viseman irregularity in surfaces; the "turner" uses it to see that the machining is being correctly done. The straight-edge is also used with the rule to measure depth of holes, and with a square to line interior holes, and with a steel scriber, in drawing lines, etc.

A straight-edge laid on the internal surface of a hole will mark a true line parallel to its axis, such as marking a key slot in the eye of a wheel.

Fig. 167 shows a *surface gauge* or *scriber*. This is an instrument used generally in vise, drill and planer work, and erecting; it marks accurately the centers of holes, points and lines, parallel or equidistant to the surface upon which it rests.

This instrument is generally made of metal; the base, shown round in the sketch, is also made square, oblong, etc., so as to be more readily adjustable to the work; the stem is fixed firmly in the base, and carries a split, movable bush or sliding-block, which can be regulated to any height and fixed by fly-nut; this sliding-block has a regulating or set screw, which engages with a block sliding on the stem; this block carries the scriber, or marking steel point, fixed firmly by fly-nut.

When in use the surface gauge is set as follows: See that the base rests firm and level; unscrew both fly-nuts and roughly adjust the point of scriber to the height required; tighten the upper fly-nut on the stem; this will probably alter the height of scriber point a little; with the adjusting screw regulate the scriber point to the exact measurement required, and at the same time tighten the fly-nut on the scriber to retain or hold it in position.

HAND-DRILLING.

A *drill* is a steel cutting-tool fixed to a drill-stock or drilling machine.

There are hand-drills and power-drills; many derive their names from the distinctive uses for which they are designed, thus:

A *centrifugal drill* is a drill which carries a fly-wheel upon the stock to maintain steady motion.

A *double-drill* is a drill with two cutters, used for making counter-sunk holes, as for screw or rivet-heads.

An *expanding drill* is a drill with a pair of adjustable bits, which can be spread apart at any given depth, to increase the width of the hole at that point.

A *finishing drill* makes a smooth cut, and is used to follow a drill doing rapid but rough work.

A *lip-drill* is a flat drill upon the cutting edge of which a lip is formed, either by grinding or during the process of forging; the lip adds to the speed and cleanness of working.

A *roughing drill* is a form of drill adapted for speedy working, but producing a rough cut.

A *teat drill* is a square-face, cylindrical drill with a sharp projection like a pyramid or teat issuing from the center of the cutting face; this is used to flatten or finish the bottom of holes.

A *twist drill* is a round drill around the body of which is carried a deep spiral groove, so that the tool appears as though twisted from a flat bar; the point is sharpened to an obtuse angle. Such drills are used in all sizes, from a diameter of three inches down.

A *vertical drill* is a drill with a vertical or upright spindle.

A *wall drill* is a drilling machine set up against a wall, and not fitted with a table to receive the work.

HAND DRILLING.

A ratchet drill.—A ratchet is a pivoted piece designed to fit into the teeth of a ratchet-wheel, permitting the wheel to

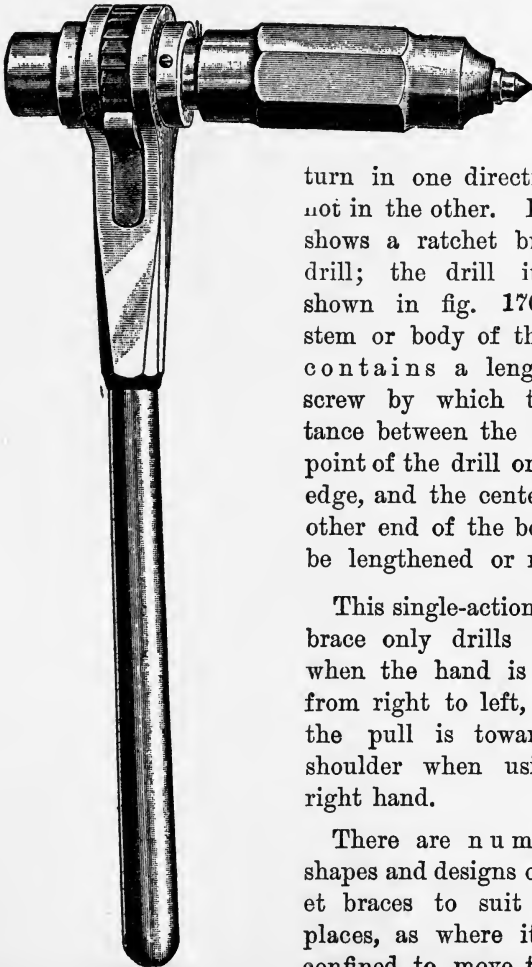

Fig. 168.

turn in one direction but not in the other. Fig. 168 shows a ratchet brace, or drill; the drill itself is shown in fig. 170. The stem or body of the brace contains a lengthening screw by which the distance between the extreme point of the drill or cutting edge, and the center at the other end of the body, can be lengthened or reduced.

This single-action ratchet brace only drills or acts when the hand is moving from right to left, or when the pull is towards the shoulder when using the right hand.

There are numerous shapes and designs of ratchet braces to suit special places, as where it is too confined to move the arm in a circle. Some are self-

acting in feed; some double-acting in the cut, having bevel gear, etc. The single action is the general shop appliance.

HAND DRILLING.

In operating the ratchet-drill or brace, it is necessary to have a fulcrum to work from. The sketch, fig. 169, shows such a device, which is composed of a strong standard with a

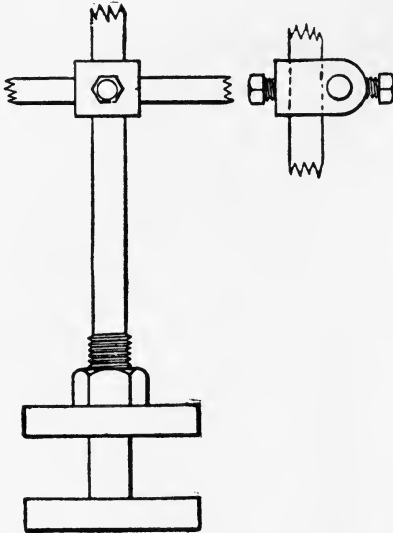

Fig. 169.

sliding-block, which carries a sliding-arm or cross bar, fixed by screws; the arm can be swivelled into any position and the base is clamped to the work, and fixed firmly by action of the nut on the top—all as shown by the two views given in the sketch.



Fig. 170.

HAND DRILLING.

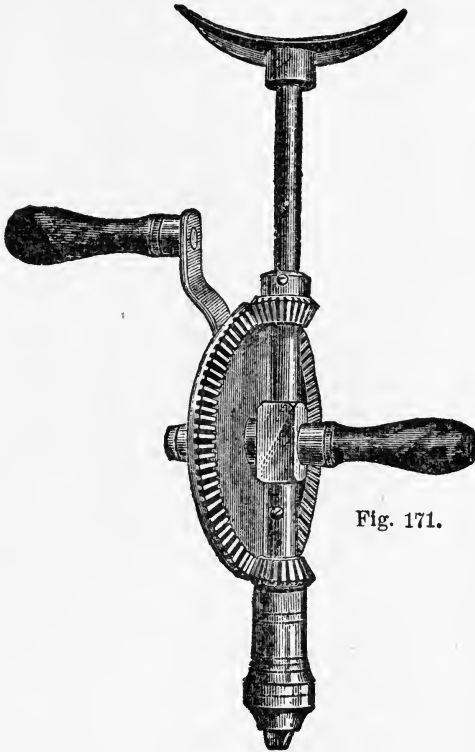

Fig. 171.

As ratchet-braces are generally used in confined places difficult to get at otherwise, the drills used with them are usually plain, flat drills, easily forged, and which can be cut quickly in the forge to the length required, and they are usually made as short in length as possible for stiffness.

When drilling between parallel surfaces with the ratchet-drill, blocking or packing is inserted to make the correct space and act as a fulcrum; at other times a bent piece of flat iron, like the letter *Z*, is used as a fulcrum.

The *breast drill*, shown in fig. 171, is a most convenient shop tool; it is used to drill centers in lathe work, and small holes in brass work, and is especially “handy” in repair-work.

BROACHING OR DRIFTING.

A *broach* is a steel tool with file teeth designed for pressing or driving through irregular holes in metal that cannot be dressed by revolving tools.

This operation requires considerable experience in preparing suitable-shaped cutting tools for the various operations to be performed.

The socket-spanner end shown in fig. 173 illustrates the operation, which comprises marking or scribing a square hole on the stock; as much as possible of the material is then removed as can be done by drilling; this is shown in the illustration by circles, one large and four small holes as dotted; then the drift, or broach, as shown in fig. 172, is forced through by repeated blows of a heavy hammer, or by pressure applied by a screw or hydraulic press, completing the making of the square opening needed to be formed in the spanner.

Broaches or drifts are made of various forms. Some are smooth on the outside, as fig. 172, the cutting part being at

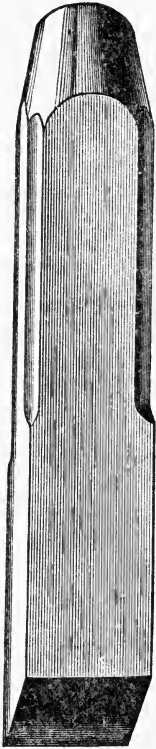

Fig 172

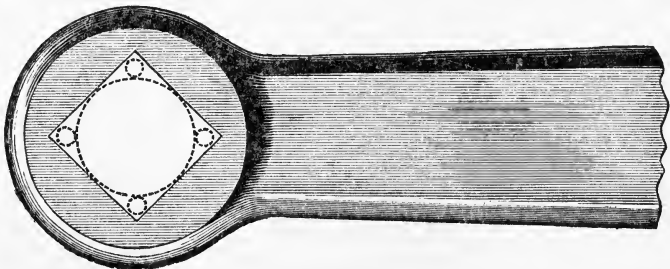

Fig. 173.

BROACHING.

the end similar to a punch; others are cut on all four sides, like a square file; another kind is shown in fig. 174, this being intended to cut slots or keyways; the blind socket or box-wrench, fig. 175, is an example of work specially suited for and which can be performed more economically and of better finish by broaching than by any other method.

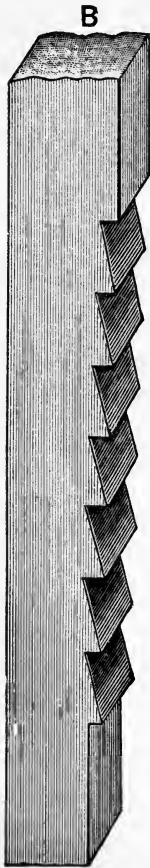

Fig. 174.

In drifting or broaching it is essential that the work rests evenly on a solid block of iron or similiar foundation; lead is often used when the material is fragile; in striking the punch, the blow must be fair and even; the great aim in using drifts is to drive them true.

Drifts should be freely lubricated when used upon steel or wrought iron.

Care must be exercised in broaching that the drift is kept upright on entering the hole in the work.

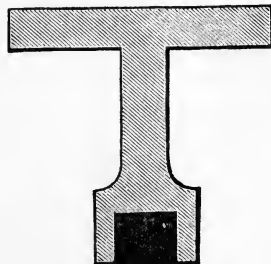

Fig. 175.

NOTE.—There are two kinds of drifts: 1, the *cutting drift* described above; 2, the *smooth taper drift*; the latter is the one used by boiler-makers to make the holes in boiler plates come fair, so that the rivet will enter, being in effect a “stretching drift.”

SCREW CUTTING.

The screw forms one of the six mechanical powers, and is virtually a spiral inclined plane, only the inclined plane is commonly used to overcome gravity, while the screw is more often used to overcome some other resistance.

Screws are *right* or *left*, according to the direction of the spiral. A right-handed screw is advanced by turning from left to right, or clockwise; a left-handed screw is advanced by turning from right to left.

A *right and left screw* is a screw of which the threads upon the opposite ends run in different directions.

A *setting-up screw* is a screw for taking up space caused by wear in journal-boxes, etc.

A *screw thread* is a single turn of the spiral ridge of a male or female screw, commonly called simply *thread*.

A *screw-gauge* is a device for testing the diameter, the pitch and the accuracy of the thread of screws.

Screw-blank.—This is a piece of metal cut from a bar preparatory to forming it into a screw.

Milled Screw.—This is a screw with a flat, broad head, fluted or roughened to afford a firm hold for the fingers.

Screw-eye.—This is a screw having a loop or eye for its head.

Screw-feed.—This is any feed governed or operated by a screw, as the feeding mechanism driving the lead screw of a lathe.

Screw-plate.—This is a tool for use in cutting small screw-threads.

Screw-press.—This is a simple form of press, producing pressure by the direct action of a screw.

Screw-punch.—This is a punch in which the operating pressure is applied to a screw.

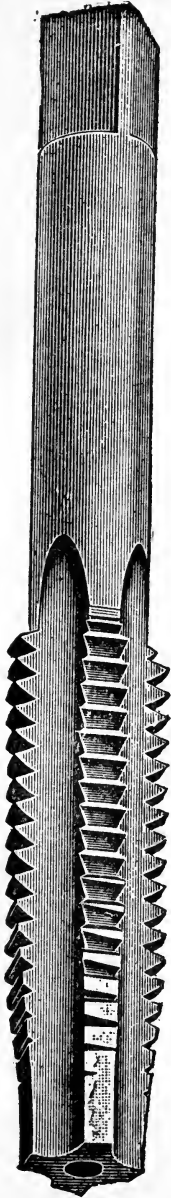

TAPER
Fig. 176.

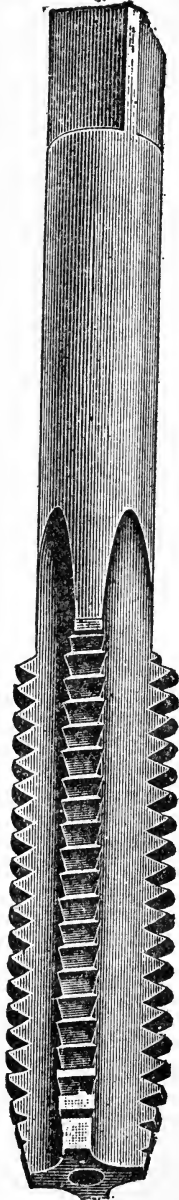

PLUG
Fig. 177.

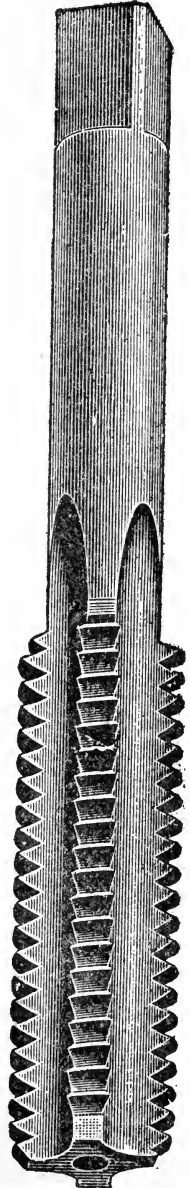

BOTTOMING
Fig. 178.

SCREW CUTTING.

Screw-tap.—This is a tool for cutting screw-threads on the inside of pipes, etc.

Screw-wrench.—This is a wrench of which the jaws are opened or drawn together by means of a screw.

Screw-cutting Lathe.—This is a lathe with slide-rests with change gears, by which screws of different pitch may be cut.

Screw-cutting is the general term applied to the operation of cutting threads, V shape or square, when performed by a machine, whether the thread is cut on the surface or the interior.



Fig. 179.

The *common screw-thread* is a V thread; the angle is 60° ; see fig. 179.

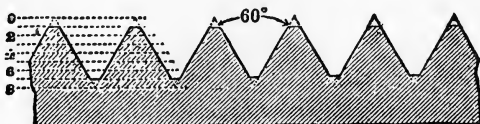

Fig. 180.

The *standard thread* used in America is this V thread, with one-eighth part in height cut square off the top and bottom, as shown in fig. 180.

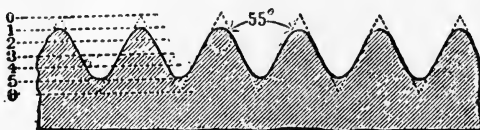

Fig. 181.

The *Whitworth's thread* is the English standard; it has a V thread at an angle of 55° ; the bottom and top are rounded for one-sixth of the height of the thread, as shown in fig. 181.

SCREW CUTTING.



Fig. 182.

Fig. 182 shows portion of these three threads as they appear on the round surface of a bolt; the center figure shows the rounded Whitworth thread.

The terms *tapping* and *screwing*, used in hand or bench-work, are not confined to hand-work, but are used also on machine-work; the term screw-cutting, on the contrary, is only applied to machine-work.

In hand or bench-work the operation is confined to V threads only, and is subdivided into

1. Tapping.
2. Screwing.

Tapping is the process effected when the thread is formed on the interior of a hole, which is done with a tap; and *screwing* when the thread is formed on the surface or outside of a cylindrical surface, as a pipe or round bar of iron.

A *tap* consists of an external screw of the required size, formed of steel and more or less tapered, part of the thread being cut away in order to present a series of cutting edges; this being screwed into the nut in the manner of an ordinary bolt forms the thread required.

Taps are usually made in sets of three. The first, called the *entering tap* or *taper tap*, generally tapers regularly throughout its length; the second, or *middle tap*, sometimes tapers, but is usually cylindrical with two or three tapering threads at the end; the third, called the *plug-tap* or *finishing-tap*, is always cylindrical, with the full thread carried to the point.

In fig. 176 to fig. 178 are shown three taps; these are made of steel, the main portion being threaded in a lathe or chaser, the grooves, four in number, being cut out with a milling machine to give room for the cuttings to escape; the round shank on the tap is made the exact size that the hole in the stock should be drilled, thus making a sliding-

SCREW CUTTING.

fit; the square part made for the handle or wrench should not have the corners or angles in line with the cutting edges, but between them.

The entering or taper tap is also called *first tap*, as it is the first used; the taper portion is smaller than the size of hole,



Fig. 183.

so that it enters it a distance equal to nearly its own diameter; this helps to keep the tap straight with the hole; in practice it is usual to test the tap on two sides with a square off the work surface, to make quite sure of its entering straight.

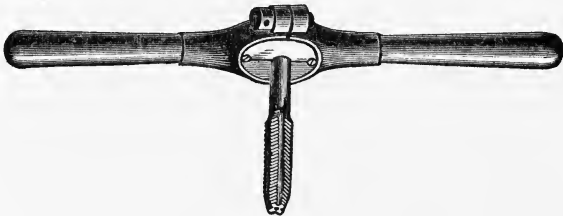

Fig. 184.

The plug or *second tap* is used after the taper tap, as, after the first has entered sufficiently to cut a full thread it becomes very laborious to work, on account of the long taper cutting surfaces acting together.

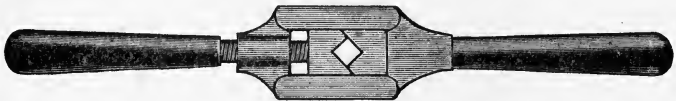

Fig. 185.

Tap-wrenches, so called, are shown in figs. 183 to 185; these are made solid, double-handled, with square hole in center to fit the square of tap; they are also made adjustable with dies, which open to admit several sizes of the tap-ends.

NOTE.—The finishing or *third tap* is seldom used except in holes which are shallow and blind; it requires great care, as, if too much leverage or pressure is used, the first thread has all the strain of the full cut, and is liable to break off; it requires judgment and practice to put enough strain on and yet not overdo it, so that the thread will bear safely when it reaches the bottom.

STOCKS AND DIES.

A *stock and die* is a tool used for cutting screw-threads, or, in other words, a screw-cutting die in its holder; or, again, an adjustable wrench with two handles of equal radius for holding screw-cutting dies, as shown in fig. 186.

The stock is very often used with blank dies to suit the square on the end of a tap, as shown in fig. 184.

Stocks and dies are arranged in sets with three assorted dies to accompany a large-size stock, and six or more dies to fit a smaller stock; but, as in all engineering tools, there are endless varieties of stocks and dies, some being very delicate and requiring great care.

Fig. 187 shows a set or pair of common dies.

In practice the dies are not closed on the bolt or work sufficient to form the thread in one cut, but by gradually working the dies back and forward, closing them gradually until the full thread is formed; if dies are closed too quickly there is fear of stripping off or abraiding the thread.

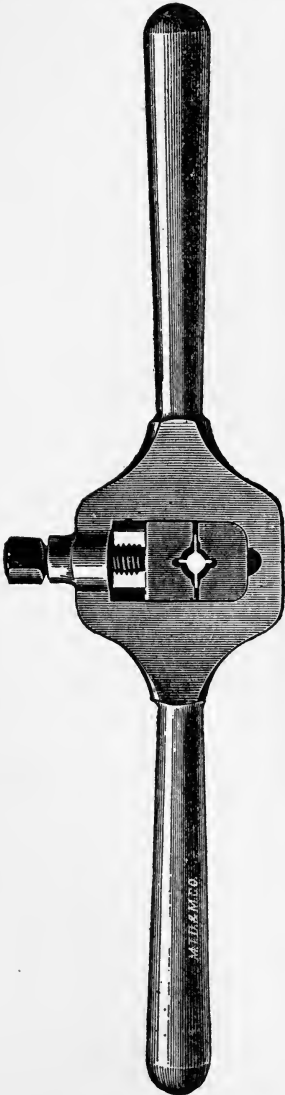

Fig. 186.

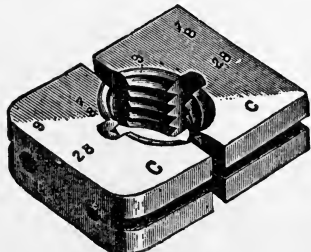

Fig. 187.

PIPE-VISE.

Oil, or soap-water and oil, should be used liberally when threading with dies.

Care must be used with the pressure put on the dies in starting the thread correctly in the first turn, and also in finishing against the shoulder, or the threads will be broken off where they come in contact with the full size of bar at the end of the screwed portion.

Special cutters or dies are used which will finish a screw-thread in a single cut; these are called *screw-plates*. They are solid or non-adjustable and arranged in sets of several in one plate, and for sizes they cut three-sixteenths or less.

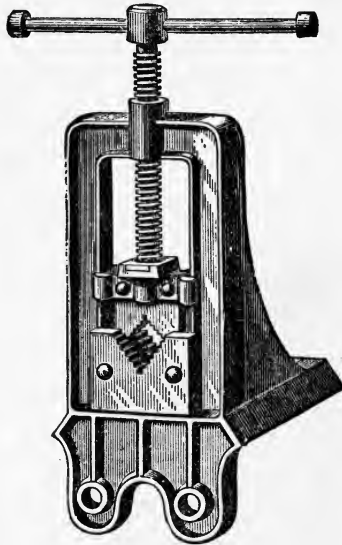

Fig. 188.

PIPE VISE.

The vise shown in fig. 188 is especially a bench tool; it is known as a pipe vise, and is designed to "grip" pipes of various sizes while they are being threaded, cut off or otherwise operated upon.

A parallel or ordinary bench vise will only grip a pipe on two points, and, if tightened, the strain will easily collapse it, owing to its hollow form; but a pipe vise is so made

PIPE CUTTERS.

that it presses upon four points, as the jaw or holding portion is formed V shaped instead of parallel.

Some pipe vises are formed of two pivoted discs instead of jaws, having semicircles or recesses, which fill all diameters of pipes up to two inches, and bear on the outside of the pipe all around.

It is an improvement to have the upper portion of the vise hinged at one end or side, and fixed with a pin or collar at the other, as it renders more convenient the removal or insertion of the pipe to be operated upon.



Fig. 189.

PIPE CUTTERS.

One of these useful, portable hand-tools is shown in fig. 189; in the upper portion a cutting device will be observed; this is a hardened steel, adjustable, circular cutter, designed to be rotated round the pipe; it is compressed into the pipe surface by the screw handle, and has two rollers which rotate on the pipe surface, to lessen the friction, etc.

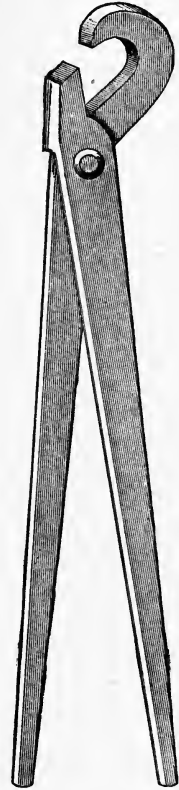

Fig. 190.

In cutting the larger sizes of pipe sometimes a special cutting-tool is introduced in place of the circular cutter to accomplish the more difficult work; in shop practice it is customary to cut the large sizes of pipe in the lathe or screwing machine; when a quantity of this work is required, a special power cutter is provided.

PIPE-TONGS.

The *gripping tongs*, for handling and holding pipe, in common use are shown in fig. 190; they are composed of a holder or circular portion and a "tong" or grip part hinged together; when the correct size is used on a pipe the grip meets the pipe at an angle, and the handles are apart nearly as much as shown in fig. 190; the pull being on the grip portion, the greater the pull the more the grip bears on the pipe surface; if too small a tongs is used the grip is tangent to the pipe and inclined to slip.

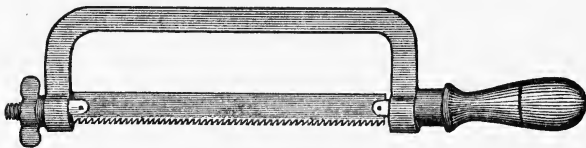

Fig. 191.

THE HACK-SAW.

A *hack-saw* is a hand-machine, as shown in fig. 191; it is a saw blade with little set, close teeth, and well tempered; it has a small, stout frame, and is used for sawing metal, as in cutting off bolts, nicking heads of hand-made screws, etc.; so very useful is this tool that many machine shops have a power-driven hack-saw, self-feeding and always ready for use, which is a necessity for cutting shafts and bars to length, preparatory to the operation in the lathe.

WRENCHES.

The word which gives this term to the tools here described is one of the strong words of the English language; wrench means, primarily, "a violent twist or turn given to something," hence, as derived, any instrument almost that causes

WRENCHES.

a twist or torsion strain comes under the above heading. A wrench is a tool used by hand to turn or rotate other tools, nuts or bolts. A solid wrench, shown in fig. 192, is formed of a single piece of metal, having a notch or opening of suitable shape and size to fit on the objects to be grasped.



Fig. 192.

A wrench is specifically designated according to the shape of the recess or aperture, as a square wrench, hexagon wrench, etc. If the opening is at one end, it is termed a single-ended wrench; if it is in the middle, a double-handled wrench, such as fig. 183. If the recess is open, it is termed an open-ended wrench; if closed, forming an aperture through the metal, a box-wrench. A solid wrench having an angular recess notched on its sides, so that any nut or bolt which will enter

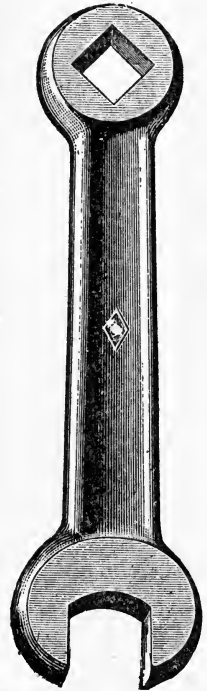

Fig. 193.

the jaws can be grasped, is called an alligator-wrench, fig. 194, and is one of the most convenient forms. To illustrate, fig. 193 is a double-ended square wrench.

ALLIGATOR WRENCH.

Again, different kinds of wrenches are called by the name of the inventor, or patentee, or shape—thus, in the shop, “Where is the Stillson?” not Stillson wrench.

Screw or monkey-wrenches are those which have a movable

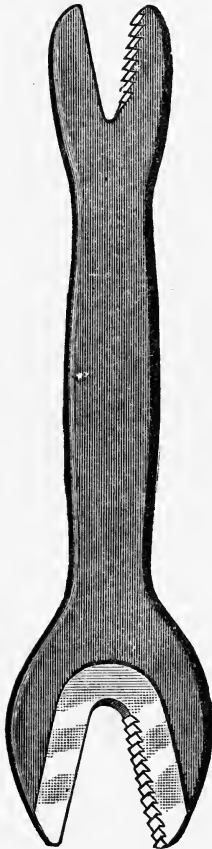

Fig. 194.

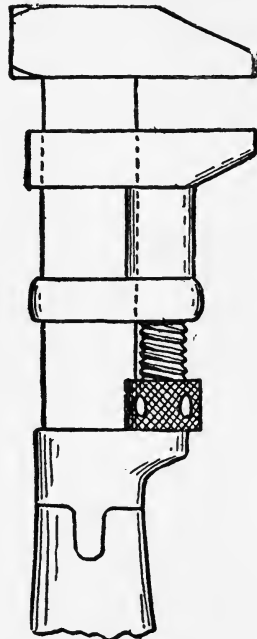

Fig. 195.

jaw, so that the tool may be adjusted to fit any sized nut within its compass; as shown in fig. 195.

A *spanner* is a special form of wrench, which circles or spans round, generally for twisting a round or circular-shaped portion provided with holes in its circumference.

It is difficult for an inexperienced hand to get a job on a lathe, but every fellow, however clever now, was quite as inexperienced at the beginning.



TOOLS
AND
MACHINES

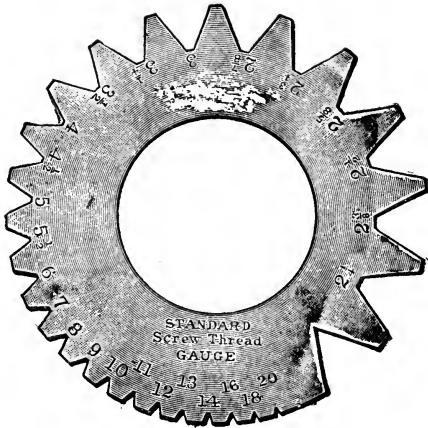

TOOLS AND MACHINES.

Tool, the word, comes probably from toil, signifying the thing with which one toils or labors, as a hammer, file or wrench.



Fig. 197.

A *tool* is that which is brought to bear directly on the work; again, it is any implement used by a craftsman at his work; it is any instrument employed for performing, or aiding to perform, mechanical operations by means of striking, penetration, separation, abrasion, friction, etc.

In practical mechanics the word tool has a restrictive meaning; a single device, as a chisel, crowbar or saw, or a very simple combination of moving parts, as tongs, shears, pincers, etc. These, for manual use, are always called *tools*, although comprised in the strict technical definition of machine.

These implements in shop practice are called "hand-tools," to distinguish them from cutting-tools.



Fig. 198.

A *portable tool* is a tool or machine tool which can be taken from place to place; example, a riveting machine.

TOOLS AND MACHINES.

A tool never ceases to be a tool, *i. e.*, something which is applied directly to the work; generally tools in machine practice cut, abrade, like a file, or strike—as a hammer.

The distinction between the words *tool* and *machine* becomes indefinite with increased complications of parts, but the difference may be generally defined as follows:

A *machine* is an aggregation of parts whose combined action makes the work of the tool more effective. *Tools* are the simplest implements of art; these, when they are complicated in their structure, become machines; and machines, when they act with great power, take the name, generally speaking, of engines—as the pumping-engine, the engine-lathe, etc.

A Machine Tool.—In the foregoing paragraphs the words tool and machine have been explained; the two combined have a separate meaning. A machine tool is a tool actuated by a mechanism; example, a drill is a tool, but one or more when arranged to do work become a machine tool; although designated as a “drilling machine” the combination belongs to the classification of machine tools; the cutter in a lathe is a tool, but the whole mechanism is a machine tool. Hence a tool operated by machinery becomes part of an aggregation of another class, *i. e.*, machine tools.

Such machines as are used in shaping materials in the construction of the parts of other machines, and also many of those which perform work, such as boring, planing, riveting, etc., formerly only done by hand, and still performed manually to a greater or less extent, are nearly always called machine tools; the term, engine tool, is more in accord with general usage when referring to large and complicated machines.

TOOLS AND MACHINES.

Special machine tools comprise a large family designed for a thousand uses, the names of which, given mostly to designate their particular service, would fill a large volume.

It is extremely difficult to classify machine tools on a strictly scientific basis, but the great family easily subdivides itself into two great sections:

First, machines for general engineering workshops, each designed to take a variety of work; and,

Second, special machine tools designed for specific purposes, among which we may put the automatic machines, though these take numerous objects of similar design.

An automatic machine, to define an often repeated term, is a self-acting mechanism—the modern lathe is probably as good an example as can be given of an automatic machine. The steam engine is automatic.

Machines are divided into *simple* and *compound*. The simple machines, or what are commonly called mechanical powers, are six in number, viz.:

1, the lever; 2, the wheel and axle; 3, the pulley; 4, the inclined plane; 5, the screw; 6, the wedge.

These can in turn be reduced to three classes:

- I. A solid body turning on an axis.
- II. A flexible cord.
- III. A hard and smooth inclined surface.

For the mechanism of the wheel and axle and of the pulley merely combines the principle of the lever with the tension of the cords; the properties of the screw depend entirely on those of the lever and the inclined plane; and the case of the wedge is analogous to that of a body sustained between two inclined planes.

TOOLS AND MACHINES.

The parts of a machine may be distinguished into two principal divisions—1, the frame or fixed parts, and, 2, the mechanism or moving parts. The frame is a structure which supports the pieces of the mechanism, and in a measure determines the nature of their motions.

The form and arrangement of the pieces of the frame depend upon the arrangements and motions of the mechanism; the dimensions of the pieces of the frame required in order to give it stability and strength are determined from the pressures applied to it by means of the mechanism.

It appears, therefore, that in general the mechanism is to be designed first and the frame afterwards—care being taken to adapt the frame to the most severe load which can be thrown upon it at any period of the action of the mechanism.

In the action of a machine the following three things take place:

FIRST.—Some natural source of energy communicates motion and force to a piece or pieces of the mechanism called *the receiver of power* or *prime mover*.

SECONDLY.—The motion and force are transmitted from the prime mover through *the train of mechanism* to the *working piece* or *pieces*, and during that transmission the motion and force are modified in amount and direction, so as to be rendered suitable for the purpose to which they are to be applied.

THIRDLY.—The working piece or pieces, by their motion, or by their motion and force combined, produce some useful effect.

MACHINERY.

Machinery.—This is a term which easily comes from the word machine, and denotes the parts of the latter taken as a whole; its secondary meaning is where a number of machines and tools are to be considered as a group, *i. e.*, the machinery in a watch factory, the machinery in a shop, etc. The machinist gets his designation also from the word machine; in the rating of the U. S. navy an engine-room artificer is called “a machinist” of different grades.

Most machines are combinations of some or all of the mechanical powers. Thus the lever is combined with the screw in a common press; the wheel and axle with pulleys in various ways, and with the endless screw; pulleys are combined with pulleys, and wheels with wheels. The wedge is the only one among the mechanical powers that does not admit of combination with others. In wheels with teeth, the number of teeth that play together in two wheels ought to be *prime* to each other, that the same teeth may not meet at every revolution, but as seldom as possible.

The strength of every part of a machine ought to be made proportional to the stress it is to bear; and no part must be stronger or heavier than is necessary, for all superfluous matter is nothing but a dead weight upon the machine, and serves for nothing but to clog its motion. The accomplished mechanic contrives all the parts to last equally well, so that when the machine fails, every part shall be worn out.

Every machine ought to be made of as *few parts*, and as simple as possible, to answer its purpose; not only because the expense of making and repairing will be less, but it will be less liable to get out of order. Any useless motions also waste some portion of the power. Uniformity or steadiness of motion is carefully to be preserved. All these advantages are more easily attained in large than in small machines.

CLASSIFICATION OF MACHINE WORK.

An excellent description of the processes effected by machine tools has been made by a well-known writer,* which is most admirable; the general subdivisions of the work commonly performed are briefly outlined as follows:

First—*Turning and Boring*; as performed in the lathe, screw-machine, turret-machine, vertical boring mill, etc., in which the work is usually made to rotate to a cutting tool or tools which, aside from feeds, are stationary. This operation usually produces curved or circular surfaces, both internal and external, but may, as in facing, produce a plane surface.

Second—*Planing Operations*; as performed on the planer, shaper, slotting machine or key-way cutter, where the work is given a straight line motion to a stationary tool, or, as in the three latter types of machines, the tool is given a straight line motion over stationary work. In the former case the feeds are given to the tool while in the latter the work usually receives one or both of the feeds. In the case of the traverse head shaper, however, the tool is given both feeds over perfectly stationary work.

Third—*Milling Operations*; as performed on the various types of milling machines where a rotating cutter produces plain, curved or formed surfaces on the work, the latter usually receiving the feeds.

Fourth—*Drilling*; the forming of circular holes in solid stock by means of a revolving tool at one operation, the tool usually receiving the feed. Drilling differs from boring in that the latter term applies to the enlarging and truing of a hole already formed.

* W. H. Van Dervoort, M.E., in *Machinery*.

CLASSIFICATION OF MACHINE WORK.

Fifth—*Grinding*; these operations involve the removal of metal and finishing of the surface by an abrasive process, the material being ground rather than cut away. The universal and surface grinding machines correspond with the lathe and planer, a rotating wheel of emery or corundum taking the place of the cutting tool in the latter machines. Grinding operations, although necessarily slow, make possible the accurate finishing of the hardest metals.

Sixth—*Punching and Shearing*; under this heading may be included all tools used for the punching and shearing of metals, and although not strictly in this class, we may include presses used for stamping and forming purposes.

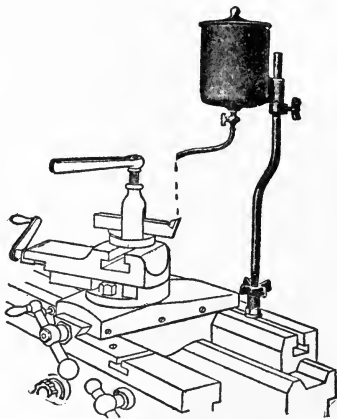
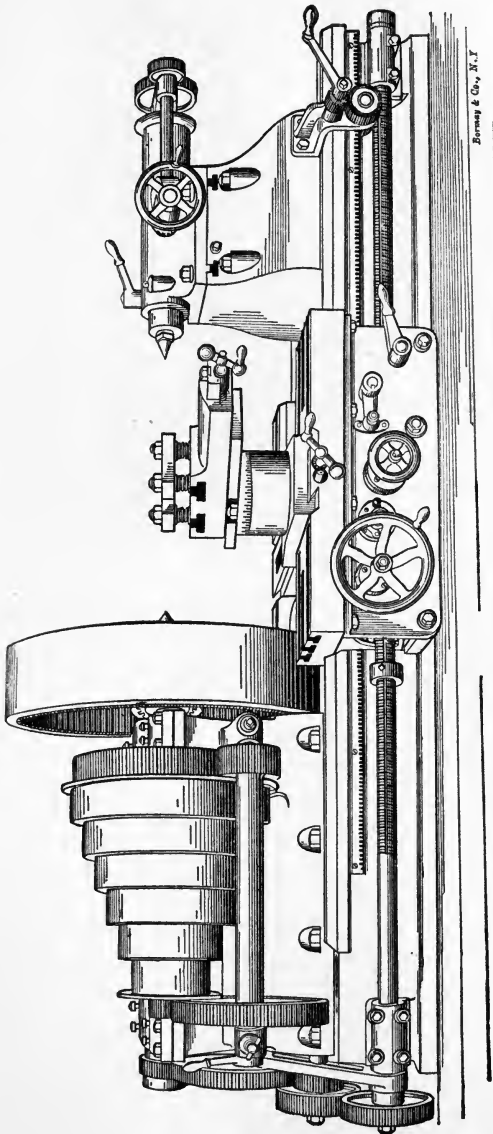

Fig. 199.



Forney & Co., N. Y.

Fig. 200. See page 303.

THE LATHE.

The *lathe* is a machine for working metals, wood or other substances by causing the material to revolve with greater or less speed, according to the nature of the material and the work to be performed, before a tool which is held at rest, although for special work and in exceptional instances the lathe is used to rotate the cutting tool, the work being fixed stationary on feed carriage, etc.

The lathe is made in a greater variety of forms than any other machine tool, and at what exact point of its development, from the simple foot lathe, it first became entitled to rank as a machine tool is involved in much obscurity, but, as far as any tools laying claims to precision are concerned, it appears to have first come into existence.

Lathes are used for boring, turning, cutting, chasing, polishing, screw-cutting, shaping, etc.; the lathe may be justly termed the most important of all metal cutting machine-tools.

It is generally understood that an expert lathe hand, or turner, "is deemed capable of operating a planer, drilling machine or any of the ordinary machine-tools, whereas those who have learned to operate any or all of these machines would prove altogether inefficient if put to operate a lathe."

All the forms of cutting-tools employed in the planer, drilling machine, shaping machine, boring machine, etc., are found amongst lathe tools, while the holding devices employed to fix the work on the lathe include very nearly all those employed on all other machines, and in addition a great many that are peculiar to itself, hence the description of lathes and

THE LATHE.

cutting tools in the following pages will answer the double purpose of describing lathe tools specially, and in general machine cutting-tools of nearly all kinds.

The multiplicity of forms in which lathes exist may be reduced to a simple classification, viz. :

1. Foot-lathes.

2. Hand-lathes.

3. Self-acting slide lathes, and,

4. The chuck or surfacing lathe, designed to carry heavy or large work, fastened to the face plate.

Below will be found a brief description of several lathes and parts of lathes useful to be noted by the student.

The *foot-lathe* signifies that the lathe driving is done by the foot by means of a treadle.

The *hand-lathe* is one that has no sliding rest, the cutting tool being held by the hand.

The *single-gearred lathe* signifies that the spindle is attached to or driven direct by the cone without any intermediate gear to reduce the speed.

The *back-gearred lathe* has gear-wheels at the back of the headstock by which the rotation of the cone (which runs loose) is transmitted to the spindle and reduced in speed.

The *self-acting lathe* is one that has a slide rest, the feed travel or traverse of the cutting tool being automatic or actuated by the rotation of the spindle in the headstock.

The *screw-cutting lathe* is one that has a self-acting slide rest, the traverse of which can be adjusted by change-wheels or gearing to cut any kind of screw thread.

When a screw-cutting lathe has two motions for the traverse, one being the ordinary slide feed and the other one for the screw cutting, it is said to be a *screw-cutting lathe with independent feed*.

PARTS OF THE LATHE.

Engine-lathe is a term that varies in its application, being used by some to denote that the lathe is engine-driven, that is, by power, as its prime mover, and they call all other lathes foot-lathes; others apply the term engine-lathe to lathes in which the tool or cutter motion is actuated by power in its traverse, and term hand-lathes all lathes which have the feed motion actuated by hand; others again only apply the term engine-lathe to lathes in which the tool motion is actuated by power both in its traverse and cross feeds.

A single-gear lathe is one that has no gearing between the cone and the live spindle.

A double-gear lathe is provided with a loose revolving cone on the live spindle, and an intermediate gearing, to reduce the speed and increase the power of the live spindle. This gearing can be dispensed with if desired, the cone being fastened to the live spindle in such a way that it acts as a single-gear lathe.

A triple-gear-lathe is provided with two sets, or a train, of gears, which increases the power three-fold, reducing the speed in proportion; this lathe can be operated as a double or single tool at will.

PARTS OF THE LATHE.

The parts common to nearly all standard lathes are as follows:

1. The bed, or shears.
2. The legs, or supports.
3. The head-stock.
4. The tail-stock, or poppet.
5. The carriage.

In addition to the above there are many subdivisions of each, and also various specially-designed parts, which will be given hereafter with some details of the work effected by their addition to the regular type of the lathe.

PARTS OF THE LATHE.

THE BED.

Fig. 201 shows a very simple end view of a lathe-bed; it will be understood that the drawing represents the part upon which the carriage travels or slides.

A is a metal rib or cross-girt, connecting the sides and the shears or top slides; this rib, or web, forms the two ends of the bed. When the latter is of unusual length additional ribs are spaced at intervals between the ends.

B B are projecting ribs on which the head-stock is fixed; on these grooves also the poppet or tail-stock slides, or is moved in position as required.

C is a flat rib on the under side of the shears, to prevent the carriage lifting; *D D* are ribs on which the carriage slides.

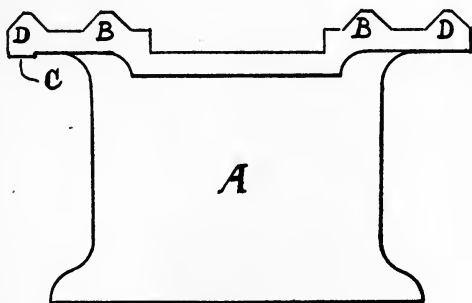

Fig. 201.

THE HEAD-STOCK.

This portion of the lathe is shown in fig. 202; the head-stock, as a whole, is shown in illustration; the details are indicated by the lettering, as follows:

- A.* Head-stock casting, which is firmly fixed to shears.
- G.* Front bearing-box; there is a similar one at back.
- L.* Bearings in which the live spindle rotates.

PARTS OF THE LATHE.

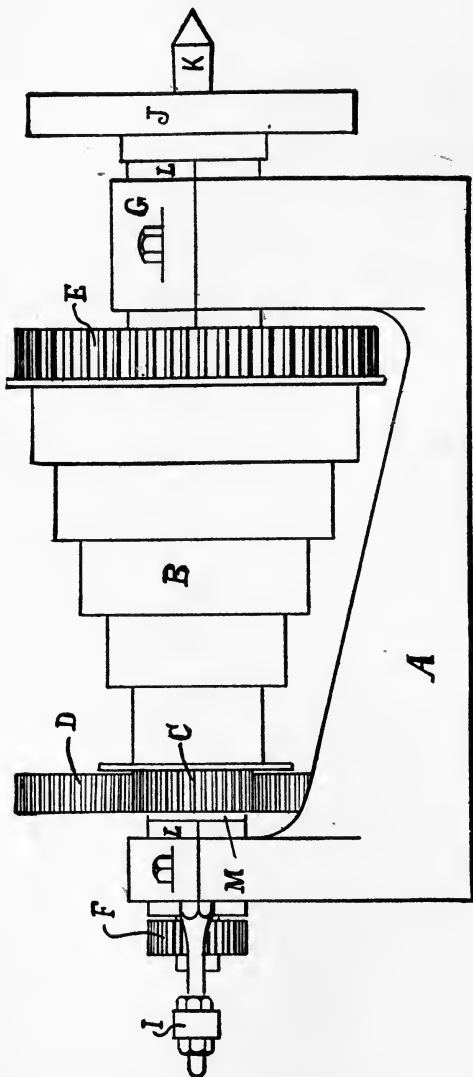

Fig. 202.

PARTS OF THE LATHE.

- M.* Steel anti-friction washer; this is loose on the live spindle between the cone and the back bearing.
- B.* Cone, which rotates on live spindle.
- C.* Pinion, firmly attached to cone; this drives the backgear.
- E.* Wheel fixed on live spindle, which receives motion from the backgear, or can be connected to cone direct.
- J.* Face-plate, screwed on end of live spindle.
- K.* Live-center, which fits into a taper recess in live spindle.
- D.* Backgear-wheel, which is fixed on backgear spindle; on the other end it has a pinion fixed, which gears into *E* wheel.
- F.* Pinion fixed on live spindle, which drives the different speed motions.
- I.* Adjustable screw, which prevents end motion to live spindle.

TAIL-STOCK.

The tail-stock of a lathe is shown in fig. 203.

It is composed of the body, *A*, in which slides the tail spindle, *F*, actuated by the hand-wheel, *C*; the body of the tail-stock is composed of the upper portion and the base; the upper portion slides on the base crosswise, and is kept in the desired position by a V projection fitting into a corresponding groove in the top of the base.

On the underneath side of the base, not shown in fig. 203, there are two V longitudinal grooves to fit corresponding ribs on the shears.

B is the base which slides on the raised ribs, *B B*, on the bed, fig. 201.

NOTE.—The object of the backgear is to reduce the speed of rotation, thereby increasing the power and enabling a heavier cut to be taken.

PARTS OF THE LATHE.

C is a handwheel fixed on the tail-screw which operates in the tail-spindle.

D is a handled nut, employed to lock the tail-spindle, *F*, in its adjusted position.

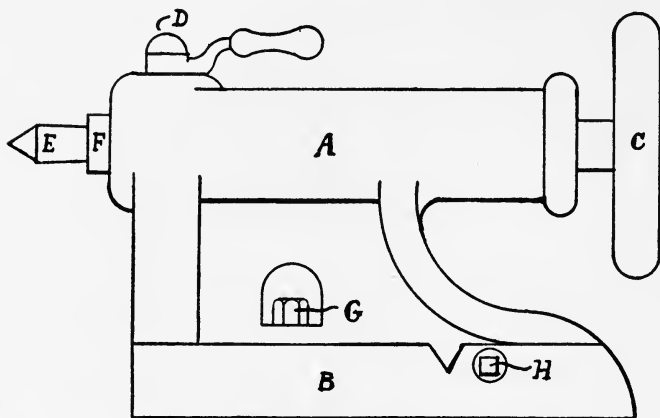

Fig. 203.

E is the center, usually called the “dead center,” to distinguish it from the “live center” of head-stock.

F is the tail-spindle or mandril, in which is fixed the dead center, *E*.

G is the nut or threaded-bolt which screws the body and base to the bed.

H is the regulating screw for sliding the body crosswise to the bed, for taper turning.

NOTE.—If the running or live spindle of a lathe revolved absolutely true in its bearing, if the tail-stock and slide-rest were in perfect contact with the bed, if the tail-stock were in true line with head-stock, and if the slide-rest moved parallel with the line of centers of the head and tail-stock, there being no lost motion in any of the working parts, or spring to the tool, the work would be cut perfectly clean and geometrically true. Therefore, in precise proportion as these conditions are fulfilled in the construction of a lathe will its performance approach perfection.

THE LATHE CARRIAGE.

Fig. 204 represents the sliding carriage, which is provided with grooves on its underneath surface, which slide on the ribs of bed, *D*, in fig. 201.

A is the saddle or bridge connecting the sliding parts; on it are the cross slides on which the compound slide-rest, fig. 207, is traversed by means of the cross-feed screw, *D*.

B is the surface of carriage; it is provided with slot grooves for fixing bolts, used for bolting material to the carriage; *D* is the cross-feed screw; *E*, a bearing or bracket on carriage for cross-feed screw; *F* is a handle to actuate the cross-feed screw, *D*.

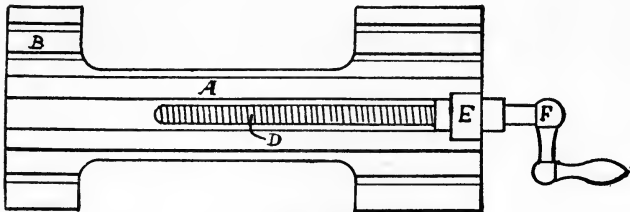

Fig. 204.

Fig. 205 is a front view of a portion of the lathe-carriage; it is called the "apron," and contains the bearings and mechanism by which the hand moves the carriage.

When the lathe is "self-acting," the gearing between the feed spindle, which communicates the motion, and the rack, which is shown on the under side of the shears, is contained in this apron, as is also the reverse motion for the feed.

PARTS OF THE LATHE.

The *apron* is tongued and grooved into the carriage, to which it is firmly bolted.

Fig. 206 shows the back or interior view of an apron; the bevel wheels show the reverse motion for the feeds, the screw-

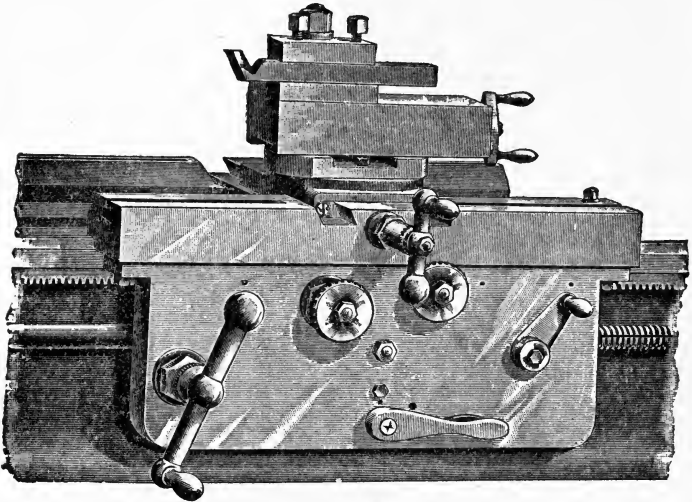

Fig. 205.

cutting feed being actuated through the half-nuts shown open; the longitudinal and cross-feeds are actuated by friction.

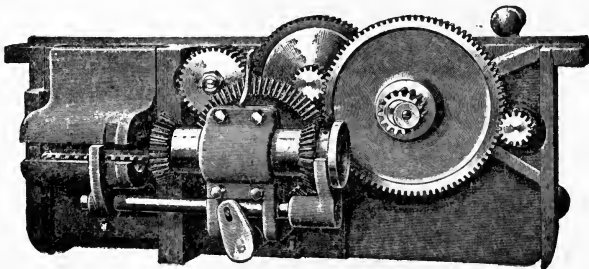

Fig. 206.

The reverse for the feeds is extremely simple, and is always at the hand of the operator. The half-nuts are planed

THE SLIDE-REST.

to fit directly into substantial bearings in the apron; they are operated by a cam, having its grooves carefully milled; the half-nuts are cut from the solid metal and are fitted with a

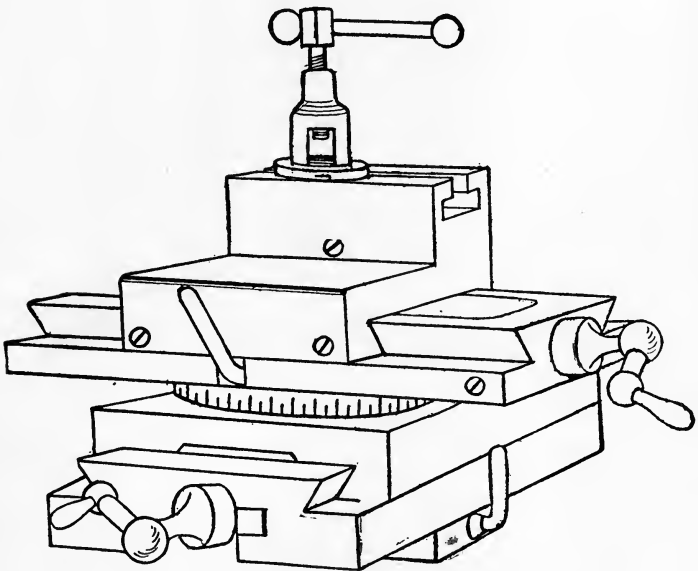

Fig. 207.

device which connects a cam with the reverse lever, which cam is thrown in the path of the half-nuts when open and the feed is engaged, so that the half-nuts can not be closed until the feed is thrown out.

PARTS OF THE LATHE.

The friction cross-feed is so designed and constructed that if the cross-feed is allowed to run beyond its limit either way no harm will be done.

THE SLIDE-REST.

A compound hand slide-rest is shown in a perspective view in fig. 207; this is virtually a part of the carriage; it consists of a lower slide fixed in the carriage, and another slide

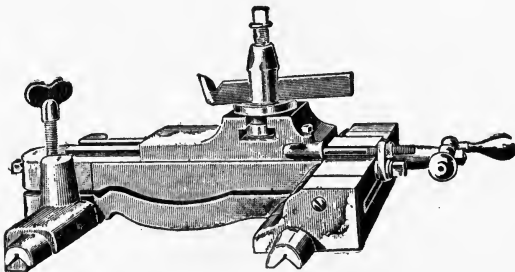

Fig. 208.

which swivels on the lower one and carries the tool-post; this carries the cutting-tool, which can be manipulated in any direction by the hand, as shown in the illustration.

Fig. 208 shows a raise-and-fall rest particularly adapted for lathes used on small work which requires constant adjustment of the height of the cutting tool; this can be quickly accomplished by the hand-screw at the end of the rest, as shown in figure; the other end is hinged to the sliding carriage.

This description of lathe rest is designed for hand feed only.

LATHE COUNTERSHAFT.

Countershafts are separate sections of shafting generally used for controlling or varying the motion of a particular machine without interfering with the speed of the main shafting.

Lathe countershafts are constructed in a variety of designs; fig. 209 shows a simple form; it consists of a pair of pulleys, one fixed and one running loose, on a short shaft, supported by two bearings; a cone is fixed on this shaft, and is connected to the lathe-cone by a belt; four alterations of speed are provided for on the cone, and the motion can be entirely stopped by moving the main driving belt from the fixed pulley to the loose one.

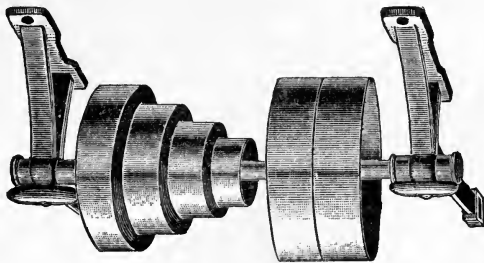

Fig. 209.

An improved form of the countershaft consists of two wide, loose pulleys, with a narrow, fixed pulley between them, and two belts, one of them crossed or twisted, so that the loose pulleys revolve in different directions, and the movement of either belt on to the fixed pulley will give a reverse motion to the countershaft; this plan as usually employed in screw-cutting lathes is an improvement adopted by which the reversing of the travel of the carriage is accomplished by an arrangement of wheels in the carriage itself, the lathe always revolving in one direction.

PARTS OF THE LATHE.

Fig. 210 shows a countershaft in which the driving consists of two loose pulleys, with a sliding friction clutch between them, through which their motion is transferred to the countershaft; both inner and outer pulleys travel in the same direction, giving two speeds of the countershaft from the different sized driving pulleys on the main line, and sixteen speeds of spindle with four-step cone.

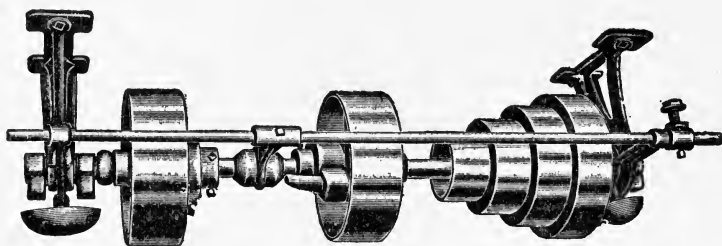

Fig 210.

All reversing of the carriage, both for thread-cutting and feeding, is done with the handle at right-hand side of the apron. This can be used with the lathe in motion except when running on the fastest speeds or cutting very coarse threads at high speeds, in which case the speed should be slackened at reversal.

In special cases, where it is desirable or necessary to run the lathe backwards, the outer friction pulley may be driven, as in ordinary practice, with a crossed belt.

TOOL-POST.

A portion of a tool-post or tool-holder is shown in section, in fig. 211.

A is the top of the slide-rest in which is a T-groove; *B* is a circular post, and is designed to turn in the T-groove.

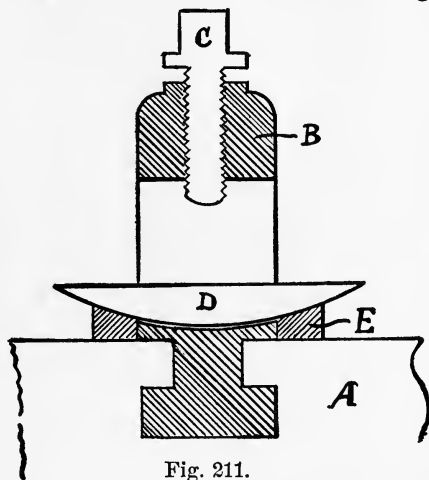

Fig. 211.

E is a cupped washer, moving easily around *B*; on this washer rests a curved gib, *D*, moving endwise in the slot in post; the tool rests on this gib, and its point can be raised or depressed by moving the gib; the tool is fixed by set screw, *C*.

Fig. 212 is a side view or plan of tool-post,

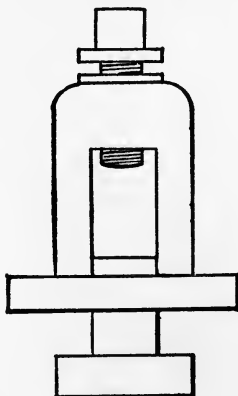

Fig. 212.

STEADY REST.

Fig. 213 is a "steady rest"; it is used when turning shaftings fixed on the shears.

It consists of a single casting, in which are spaced three sliding-blocks actuated by screws; the steady rest when bolted to the sliding carriage and traveling with it is called a follow rest.

The piece of shafting is passed through the steady rest, and the three slide-blocks in it are adjusted by the screws to press evenly against its surface, thereby acting as a bearing, and preventing vibration from the operation of the cutting-tool.

The producing of satisfactory results in the use of the follow rest requires good judgment on the part of the operator. It should be set as soon as possible after the cut has left the dead center and while the work is rigid and true. Any irregularities in the work surface on which the follow rest passes serve to reproduce these same irregularities throughout the length of the work, and it is, therefore, very important to start exactly right. In the cutting of threads on long, light rods the follow rest is indispensable. It is also of value in steadying work that is being operated upon by a cutting-off tool. It is superior to the steady rest for this purpose, inasmuch as it can be set so much closer to the point where the cut is being taken.

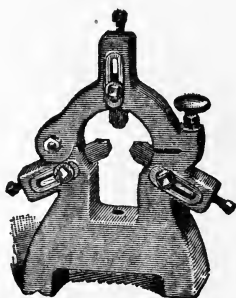

Fig 213.

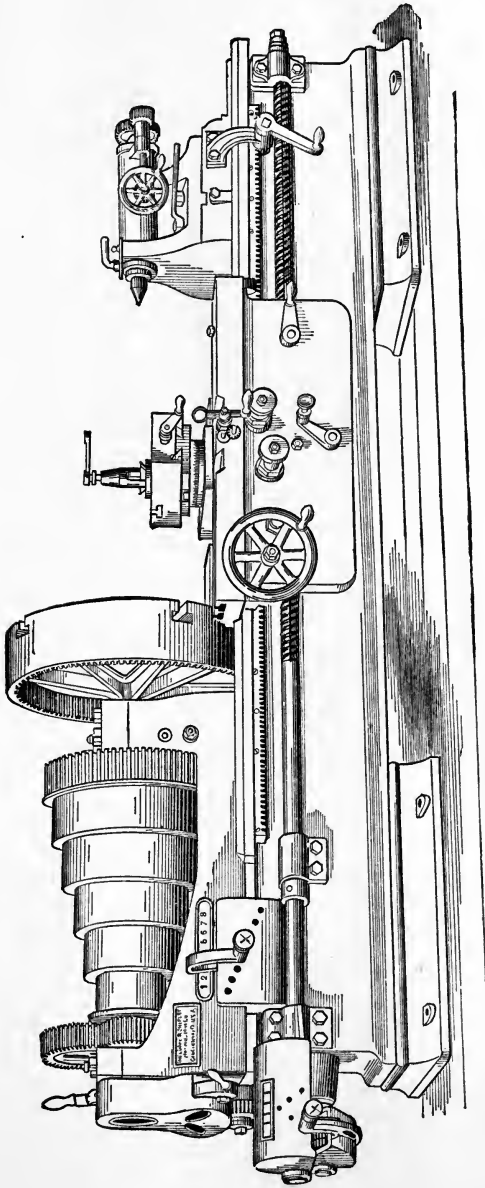

Fig. 214. See page 304.

CUTTING-TOOLS.

Cutting-tools for lathes, planing machines, etc., are made of a special grade of cast steel known as tool steel; this is first forged to shape as nearly as possible; next, the tools are of necessity filed up more or less, after the forging, on account of their shape.

When the desired form is attained, whether by forging or filing, the tool is heated to red heat, dipped into water and then tempered, as described in pages 143 to 149, and afterwards ground to sharpen the edge; too much grinding will alter the form and the temper of the edge, wearing away the tool needlessly.

The shape given to any particular tool is determined partly by the kind of metal to be turned, and partly by the nature of the work the tool has to do. The chief points to be borne in mind are that the cutting angle should be keen enough to cut well, while strong enough to stand the strain of cutting without breaking.

NOTE.—In connection with this subject, reference is made to the important discussion of "Tempering and Hardening Metals," beginning on page 143; to this is added a quotation from an article in the *American Machinist* of a recent date, contributed by Mr. Tecumseh Swift, M.E.

"The hardening, tempering and annealing of our tools is the most responsible operation of the shop; the heating and cooling of steel, the two simple but responsible operations involved in all our hardenings and temperings and annealings, are the two operations of the shop which we need to perform with the most precise accuracy and with the most perfect control. The anomalous fact is the precise reverse of this. We put a piece of steel through a long process of careful shaping and finishing; we provide means for most accurately gauging it, and set to ourselves limits of inaccuracy beyond which we may not go. We bring the piece to the last and most important process of all, with the work up to this point done precisely according to the most exacting requirements, and then we do the last thing of all upon it, the one thing upon which the success and value of all the previous work entirely rests, *by almost pure guesswork*, and it is more by luck than by skill that it is only occasionally that we actually spoil a piece.

"It is not out of place to call attention to the very unsatisfactory state of affairs in this important operation of the shop, *because it seems to be possible to do much better than we are now generally doing, and the gas furnace and the pyrometer seem to offer vast possibilities in the line of improved practice.*"

CUTTING-TOOLS.

Rake Cutting-angle and Clearance.—The angles are generally referred to as “top rake,” the “cutting angle,” and “clearance,” and also “side rake,” as shown in fig. 215; B is the angle of top rake, C is the “cutting angle,” and A is the angle of clearance.

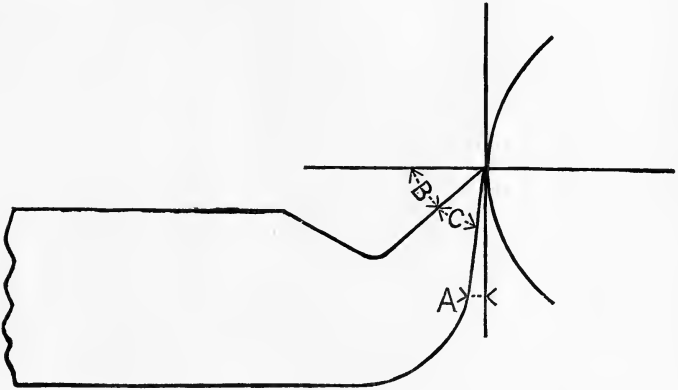

Fig. 215.

Increasing the “top rake,” or “side rake,” relieves the pressure on the tool, but this is done at the expense of the strength of the tool point.

A correctly shaped tool properly applied to the work will cut cleanly and well, and will leave a smooth, even surface behind it; it should be so applied to the work as to afford sufficient “clearance” underneath, to prevent it rubbing instead of cutting, and sufficient relief, or “top rake,” as it is termed, to enable the cuttings to easily come away from the metal.

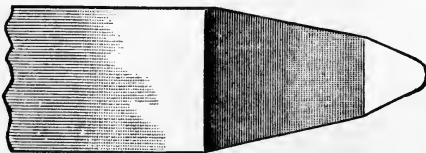

Fig. 216

CUTTING-TOOLS.

The outline of the tool shown above is well suited for turning wrought iron or mild steel. Fig. 216 shows the plan of a straight-turning tool. Fig. 217 shows a perspective view of this tool in which *AA*, *BB*, represent the top and bottom levels of the tool steel; *C* is the top face, *D* is the bottom face; *E* is a line at right angles to *A* or *B*. Referring to the top face, *C*, its angle or rake is its incline in the direction of the arrow; in many cases it is impracticable to give top rake, the necessary keenness must be given by side rake, which is done by reducing the cutting angle formed by the top and side faces.

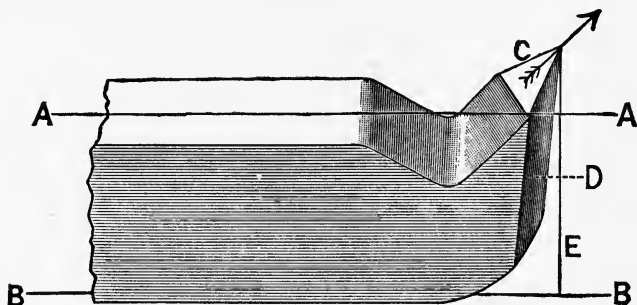

Fig. 217.

The angle *C*, fig. 215, varies slightly, according to the metal which is being turned, certain cutting angles having proved by experience to be the best suited to different metals. For example; for wrought iron and mild steel, an angle of about 55 degs. gives the best results, while for cast iron a somewhat more obtuse angle, from 58 degs. to 60 degs., is best.

Differences so exact as this, however, may be disregarded in practical work, and it may be taken that an angle of about 58 degs. will be found satisfactory for all-round work on the above-named metals. For heavy cuts on cast iron a more obtuse cutting angle may occasionally be required to give the necessary strength to the point of the tool.

The cutting angle being thus determined, the "clearance" and the top rake have still to be provided for. The object of the clearance is to enable the tool to cut without rubbing

CUTTING-TOOLS.

against the work. For this purpose a very small angle, 3 degs. or 4 degs., is sufficient; and, indeed, an excess of clearance is injurious, as it weakens the point of the tool.

While dealing with the subject of "clearance" it may be well to emphasize the necessity of grinding the side faces of the tool, which form the cutting edge, perfectly flat; this requires skill to accomplish, and neglect of this matter will cause trouble; a slightest rounding at the edge will cause the tool to rub, and destroys its efficiency.

The top and side faces, taken one in conjunction with the other, form a wedge, and all machine tools are nothing more than *cutting wedges*; the performance of these depends on, 1, the keenness of the meeting faces, and, 2, the position in which the tool is applied to the work.

To get the best results from a tool it is necessary to slope the top surface sideways as well as backwards from the point, the highest side being the leading side in the direction in which the tool is moved when cutting; this is known as side rake, and its effect is to lessen the power required to feed the tool along, the cutting edge penetrating the metal so much more easily.

A tool with side rake is suitable only for traversing in one direction; this is no real disadvantage, as nearly all turning is performed with the tool moving from right to left.

When possible all turning tools are forged with a swan-neck on the top surface of the tool, as shown in fig. 322; it will be apparent that this form can be reground or sharpened, and retain the original rake, which could not be done with a flat tool.

Variation of Rake with Height of Tool.—With the same tool the top rake varies with the position, the rake being greater for the same cutting angle the higher it is above the center; hence when sliding, and the heavier the cut, the more the tool should be packed up; in heavy roughing the tool is often considerably above the center.

CUTTING-TOOLS.

Fig. 218 shows a tool, with little top rake, placed at the center; this tool, as shown, will not properly cut the material but will scrape it off; now if the tool is raised above the center, the angle of contact will be changed, and it will cut the material.

A few actual trials in the lathe with the position of the tool altered in various ways, will soon enable the student to grasp the importance of these facts.

For surfacing work, *i. e.*, going over a face at right angles to the axis, the tool must obviously be on a level with the axis, or it would leave a circle of metal untouched at the center.

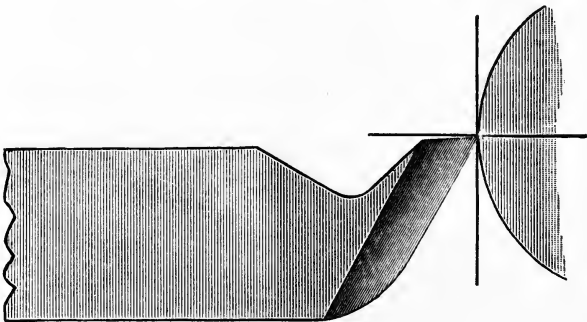

Fig. 218.

Influence of Material on Cutting Angle.—The angles of cutting tools vary with the metals operated on; wrought iron being tough, requires a good top rake, as in fig. 215, and abundance of lubricant to turn away the cutting, otherwise the metal will crowd or stick on the tool face, and the material is torn instead of cut. On brass or cast iron, which are brittle, the top rake needs to be less keen, fig. 218, is approximately correct for brass and cast iron; when a very smooth cut is required on brass work, the top face of the tool is ground quite flat, without any “top” or side rake.

CUTTING-TOOLS.

A set of *slide-rest tools*, which are sufficient for all ordinary work, will now be described; the most generally used tool is the front turning or roughing tool, shown in fig. 217, which



Figs. 219-230.

will serve for turning work between centers, and also for facing work held in the chuck. Occasionally, however, surfaces have to be turned which cannot be reached with a straight tool of this kind, and for which side-tools have to be used. A

CUTTING-TOOLS.

right-hand side-tool and a left-hand side-tool are illustrated in figs. 231 and 231a. They are ordinary swan-neck tools, with a top rake, and having side rake to the right or left, as they are

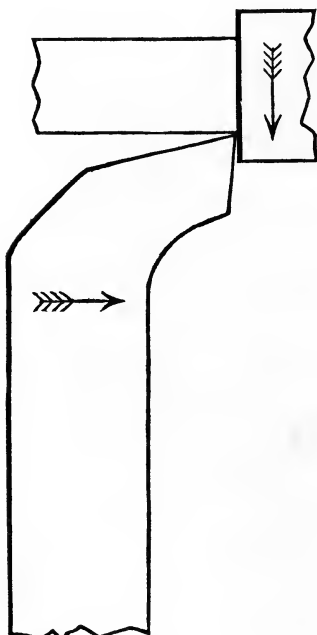

Fig. 231.

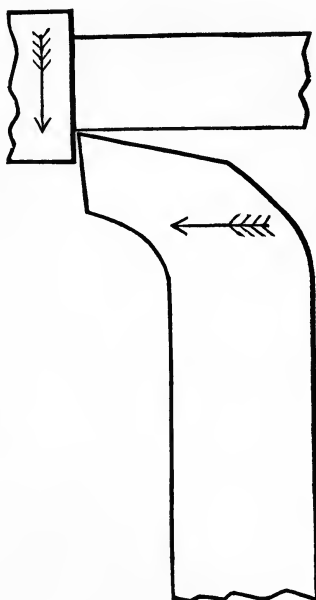

Fig. 231a.

intended to travel, as shown by arrows; they are used as illustrated in figs. 231 and 231a, and also with the cutting point rounded off, when used with a coarse traverse feed.

This tool occupies considerable breadth of space, as clearly shown above; when the work is confined and there is but little room for the tool to pass, a knife-edge side-tool is used,

CUTTING-TOOLS.

as shown in figs. 232 and 233; this tool is used to finish the shoulder after the "front" tool is used, which only takes the

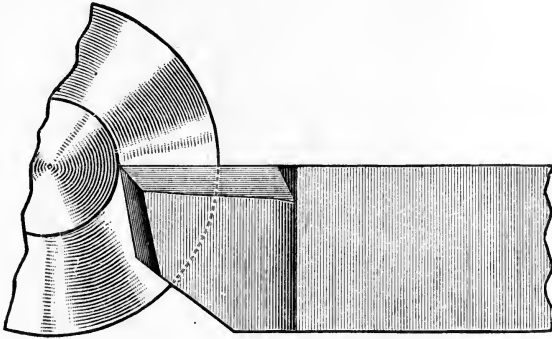

Fig. 232.

straight cut nearly up to the shoulder and leaves a rounding or fillet after it. These tools are also largely used for facing

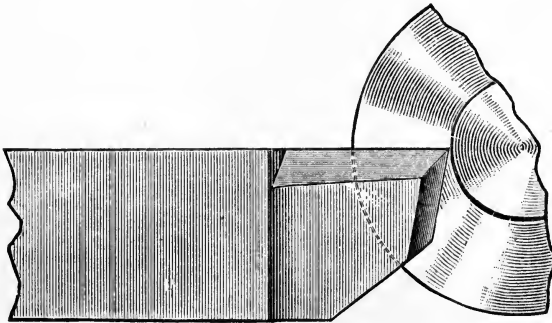

Fig. 233.

bolt-heads, collars and shoulders, and it is important that there should be sufficient clearance to the cutting edge.

CUTTING-TOOLS.

Fig. 234 shows a bent parting tool, which is used near the surface plate, where it would not be possible to reach with the straight tool.

Fig. 235 shows a plan of a very important tool for cutting-off work in the lathe; it is called a parting tool, and it will

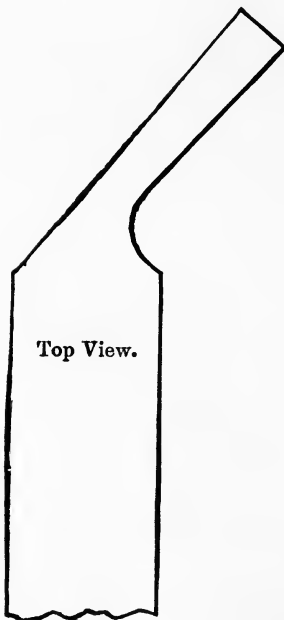

Fig. 234.



Fig. 235.

be seen that the front of the tool—its cutting edge—is wider than the back, to give it clearance sideways and to prevent it rubbing at the sides, as it advances into the work; this tool is generally flat, on the top, which must not be higher at the cutting point than the center of the lathe, as it is intended to **cut the way** into the center of the work operated on.

CUTTING-TOOLS.

The Roughing Cut.—In heavy cutting the tool springs in or out according to the weight of the cut, and copies more or less the unevenness of the forging. Hence, in “finishing,” the tool should be set down as much as convenient, so that if it meets any extra weight the tool will spring away and remove the difference at the next turn. This is carried to a greater extent in the “spring” tool, fig. 236, which yields about

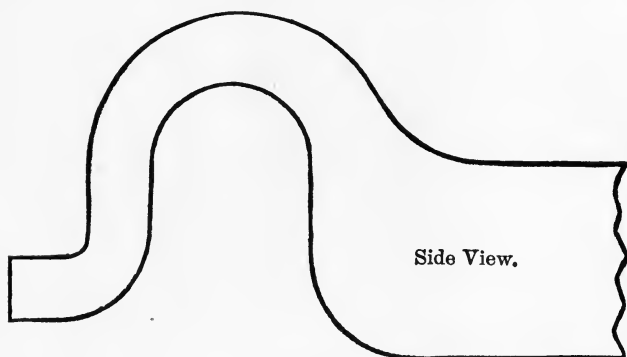

Fig. 236.

the bend, and comes away from the work in the event of excessive pressure coming on the point. This tool will often keep cutting three or four revolutions without any advance of the top slide.

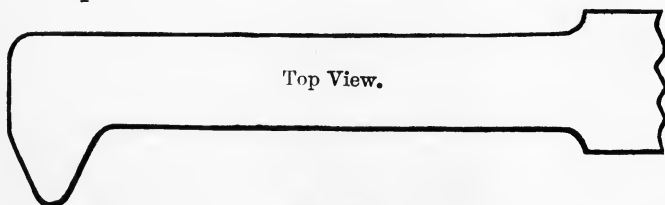

Fig. 237.

Boring in the Lathe.—Boring in the lathe is done generally by means of flat drills, which are centered at one end and ground at the other into either “point,” “rougher,” or “finisher.” Great care is taken in setting these drills, especially the “finisher,” as, when once set, it lasts a long time, and can always be relied on. If one corner is in advance of the

CUTTING-TOOLS.

other it will catch the cut first, and will be pushed away, with the result that the hole is bigger than the drill. Their accuracy is generally gauged by resting the centered end on a coned point fixed to a table, and with one corner making a mark. On turning the drill to the other corner it should come on the same mark.

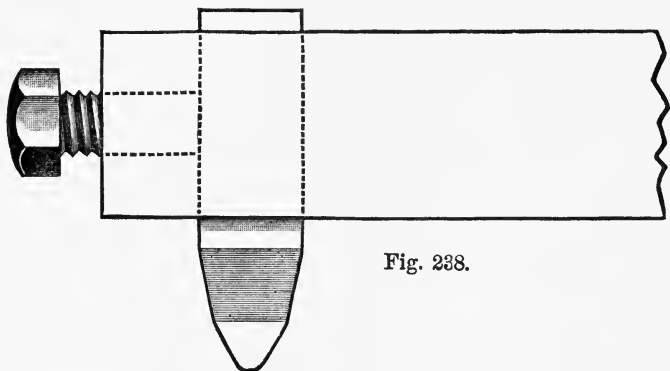

Fig. 238.

Fig. 237 is a boring tool, used in the lathe for enlarging holes cored or drilled; when the size of the hole permits the tool is made of large size; and when the hole is deep and will allow it, a strong bar, having a cutting-bit fixed in a slot, or hole with a set screw, is used, as shown in fig. 238.



Fig. 239.

The tools so far described are intended for turning either cast or wrought iron or steel. For brass and gun-metal, tools of other shapes are necessary, the principal difference being that no top rake is required. If a brass turning tool is too keen, it will rip the surface of the metal instead of cutting smoothly.

A suitable front tool for brass is illustrated in fig. 218 and fig. 239, from which it will be noticed that rather more clearance is allowed than with tools for iron.

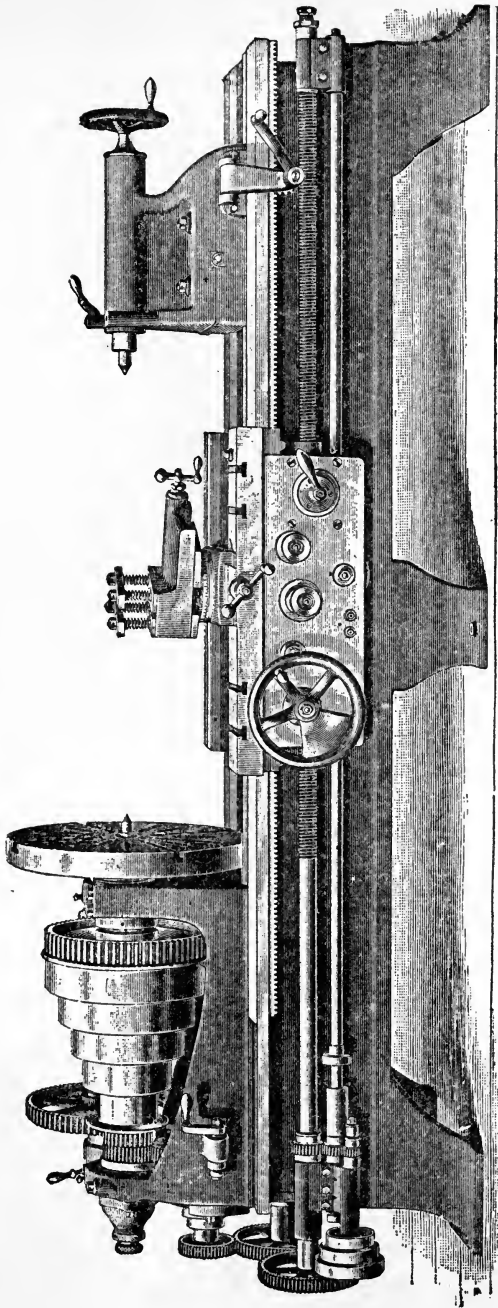

Fig. 240. See page 304.

TOOL-ROOMS.

An eminent engineer has said: "Show me your tool-room, and I will tell you the character of the work which you turn out."

A tool-room is part of every well-organized machine-shop; many tools and instruments are so important that they must, perforce, when not in use, be kept under lock and key.

One man, usually the foreman, has charge of the tools and materials contained in the tool-room; as the size of the shop,

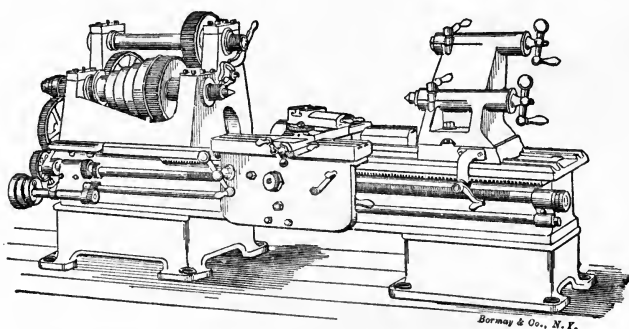

Fig. 241. See page 304.

number of men and variety of work are increased, the tool-room becomes a distinct department, with many classifications and men employed to carry on the work arising from the system adopted.

The location for the tool-room depends largely on the general arrangement of the shop, but the tool-room should always be located so as to have good light, and the location should be a central one, taking into consideration where the men work who use the tools to the greatest extent. If there

TOOL-ROOMS.

is sufficient space, the tool-room should be located outside of the shop proper, with a large opening between them. A tool-room should be equipped with shelving and racks, not located against the wall, the shelving being inclined at such an angle as will permit each tool to be readily seen.

The shelving should be neatly divided up by strips, so that each tool will have its own particular place, and prevent damage on account of the tools striking together. The tools should be arranged in the pockets made by the strips, so that tools of about the same size will be kept together. The racks should be so arranged that they are readily accessible from either side, and can be reached without interfering with the work at the machine tools that may be located in the tool-room, and the shelving should be arranged so that the larger tools can be kept on the lower portion of same.

In addition to these racks, one or two revolving racks should be provided adjacent to the window from which the tools are handed out, on which revolving rack the smaller tools can be kept, so as to facilitate their delivery to the workmen. Shelving and hooks should be provided, for the templets and gauges, also a rack for pipe-tongs, straight-edges, etc.

The machine tools to be placed in a tool-room depend largely upon the size of the shop and the policy of the management as to manufacturing taps, reamers, etc., or buying them outside.

NOTE.—In order that the tool-room may be a success, the man placed in charge of same should be carefully selected. He should have had considerable experience—the more the better—in the making of tools, neat and orderly in all that he does, and a man who thoroughly appreciates the necessity for preserving standards, as the preservation of many standards depends largely upon the proper maintenance of the tools ordinarily kept in a well-regulated tool-room. A tool-room, if well handled by such a man, will insure that the tools have proper care and can be found when required. It also makes it possible to collect together tools that have become obsolete, so that they can be condemned, or altered, to suit the standard requiremen...

TOOL-ROOMS.

All standard tools that are in general use and are required to be kept to standard sizes, should have a place in the tool-room. This would naturally include taps, reamers, drills, dies, templets, jigs, ratchets, clamps, callipers, etc. In addition, all tools in general use, that require special adjustment, should be kept in the tool-room, such as hydraulic jacks and pneumatic tools. The tool-room is the proper place for lathe tools, planer tools and chisels, over and above a certain number to be kept at each machine, or by each floor hand, as may be determined upon by the master mechanic of the shop. The tool-room is also the proper place for all test gauges.

Each shop in practical operation makes its own rules for the delivery and return of tools to the tool-room; in order to prevent delay, the workmen should not wait until they actually want a tool, but should anticipate their wants, so that the tool can be brought to them by the time it is required. The returning of the tools to the tool-room can be handled in the same way as the delivery.

If the size of the plant will warrant it, it is advisable that there shall be a tool dressing fire near the tool room, together with a small power hammer, at which fire the dressing of all tools should be done; also, a list of all workmen entitled to obtain tools from the tool-room should be printed alphabetically, and each name should be numbered in consecutive order. The list should be neatly framed and hung up in the tool-room near the delivery window.

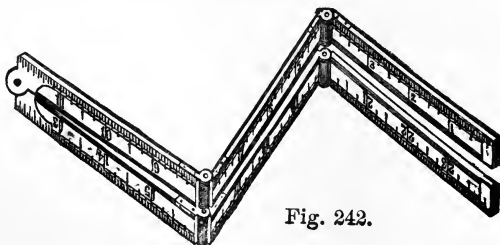

Fig. 242.

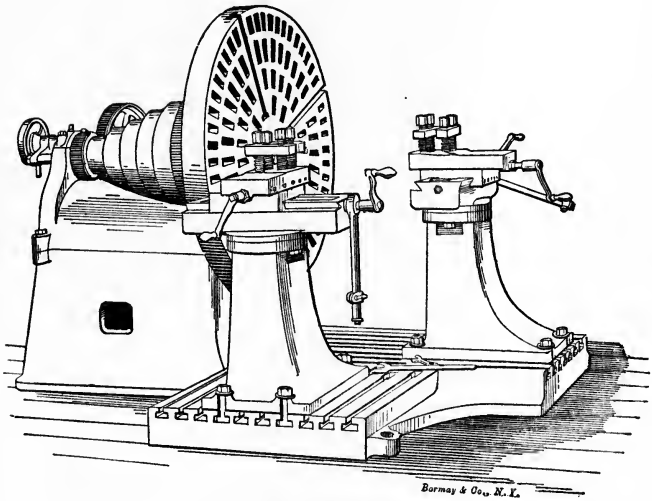

Fig. 243. See page 305.



LATHE

AND

SHOP

RULE FOR TEMPERING TOOLS.

Heat from two to three inches of the end of the tool to a cherry red, and hold it vertically in a pair of tongs, quickly dip about one inch into cold water, holding it under the water for several seconds; this makes the point dead hard; then withdraw it from the water and rub the end of the tool with a piece of sandstone or emery cloth, until the surface is clean and bright. Watch this end; it will change color as the heat travels down from the heated upper portion which was not cooled; a band of colors will be noticed traveling down to the point very slowly; the front of this band is a pale yellow, which merges into a deep yellow, then to a brown, then to a plum color, then to a purple and, lastly, to a blue; when the dark yellow color has reached the point of the tool, the latter should at once be dipped deep under the surface of the cold water, and allowed to remain there until quite cool; the rule is, the darker the color the softer the tool—the pale yellow being the hardest, and the blue color the softest.



TUBAL CAIN,
THE FIRST TOOL MAKER.

LATHE PRACTICE.

Lathe tools of the kind shown in the foregoing sketches should be made of the fine grain cast steel known as tool steel. The steel should be heated and hammered out nearly to the shape of the required tool, care being taken not to make the steel too hot when heating it, or it will become brittle and the point will chip and crumble away when the tool is applied to its work.

A bright cherry red is the best heat to work at, and it should be borne in mind that the thinnest parts of the tool will get hottest first, and if not carefully watched may overheat and get "burnt" before the thicker parts are properly hot.

When the tool has been hammered out to something like its proper shape it should be allowed to cool slowly, so as to get thoroughly soft; it may next be filed or ground to the exact shape required. When the correct shape is obtained the tool must be hardened and tempered. This may be done by the rule printed on the opposite page.

MEASURING APPLIANCES.

The *measuring appliances* required for metal turning are comparatively few in number, and simple in construction; first, a 12-inch steel rule should be obtained, divided into eighths, sixteenths and thirty-seconds of an inch; a shorter steel rule, either 4 or 6 inches long, divided in the same way, will also be useful.

Steel rules are much better than wooden ones, as the graduations are finer and more accurate, and a steel rule is frequently very useful as a straight-edge.

LATHE PRACTICE.

Fig. 153, page 170, shows a pair of outside calipers, used for measuring the external diameter of round shafting, etc.; the legs are opened until they just touch on both sides of the work with but little pressure being applied; if they are then placed on the steel rule, as shown in fig. 349, the diameter of the work can be closely and correctly ascertained.

Similarly, if it is required to turn a piece of work to a given diameter, say one inch, the caliper's legs are applied to the

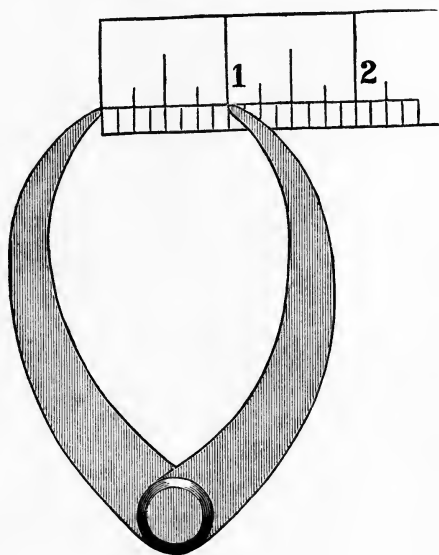

Fig. 244.

rule, as shown, and opened out until the right leg touches the one-inch mark; the work can then be reduced in size until the calipers just pass over it.

Fig. 154 shows a pair of inside calipers as used for measuring internal diameters; these can be set "to size" on a steel rule, in the same way as described for outside calipers; the end of the rule should, however, butt up against the face plate or other flat surface, to keep the point of the caliper leg perfectly level with the rule end.

LATHE PRACTICE.

Fig. 245 shows the inside calipers testing a hole; one point or leg should be kept stationary, while the other is oscillated to and fro, as indicated by the dotted curve line *AB*; the legs should be opened out until the point which moves in the curve just touches the surface of the metal; this will then give the exact diameter of the hole as required.

Caliper legs should never be adjusted by knocking on the points, as these will thereby become bruised, and so render them useless for accurate work; they should be set by tapping gently the *upper portion* of the leg only.

When it is desired to turn a piece of metal to fit a hole, the inside calipers should first be set to the exact size of the hole,

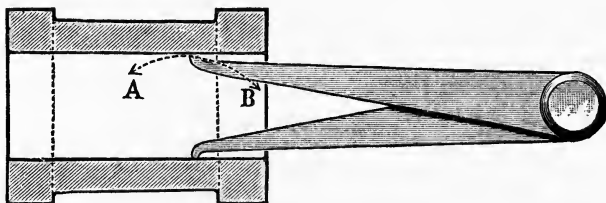

Fig. 245.

and then the outside calipers set to just touch over their points, as shown in fig. 246. The hands show the most convenient way of holding the calipers for this purpose. It will be noted that the lower points of the calipers are supported in contact with each other by one of the fingers of the left hand, while the other points are tried together until the required degree of touch is obtained. If a "working" or "sliding" fit is required, the spindle to be turned must be slightly smaller than the hole in which it is to run, and the larger the diameter of the hole the greater must this difference be.

NOTE.—It may vary from nearly one-two-thousandth part of an inch in small spindles of about a quarter of an inch diameter, to one-one-hundredth part of an inch in twelve inches diameter.

LATHE PRACTICE.

A knowledge of the proper allowances to make in size for obtaining a "sliding" fit, "driving" fit, "shrinking" fit or "forced on" fit, can be obtained only from practical experience, like a great many other useful items of knowledge.

- A "sliding" fit is a working fit of perfect cylindrical form, of sufficient difference in sizes in the diameters as will permit one surface to revolve within the other freely.
- A "driving" fit is a fit between two true cylindrical forms, of such a difference in their diameters that they only come together by driving with a hammer, sledge or a ram, in proportion to the work.

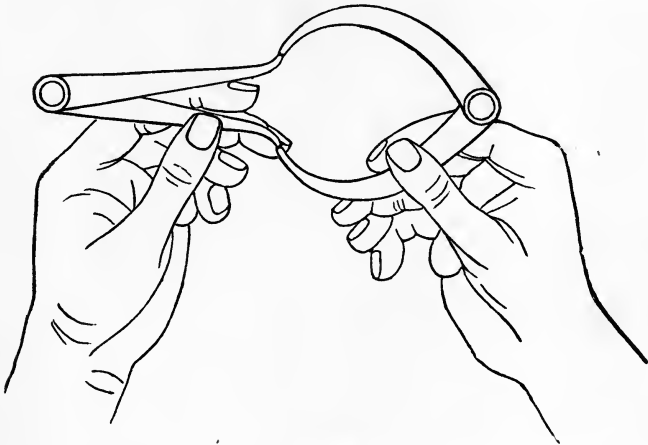

Fig. 246.

- A "shrinking" fit is a fit between cylindrical forms, of such differences in diameter that the outer surface or ring requires expanding by heat to permit it occupying its intended position on the inner cylinder; a "shrinking" fit is a considerably tighter fit than a "driving" fit.
- A "forced" fit is used only in very heavy work; it requires hydraulic force to put the parts into the desired position.

NOTE.—The student should practice with a pair of calipers until he can readily detect the smallest differences in the size of work by the "feel" of the points when touching the work.

LATHE PRACTICE.

While very minute differences in size can be detected with a pair of calipers, it is obvious that they cannot be set to a given size with absolute accuracy by measuring from a steel rule, yet with a good rule and keen eyesight on the part of the user, it is possible to set them to within $\frac{1}{64}$ th of an inch of the required size. Where greater accuracy than this is desired, vernier calipers or micrometer calipers (see fig. 247) must be used; with the latter instrument a measurement to the thousandth part of an inch can easily be made.

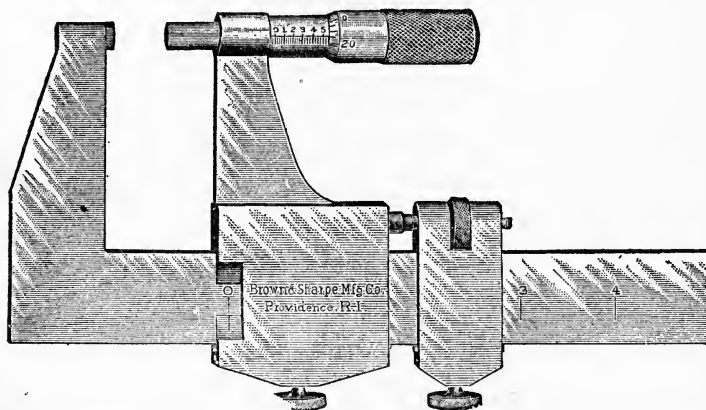

Fig. 247.

Figs. 249 and 250 show a "plug and collar gauge"; these are made a sliding fit, and are used to test the size of internal and external cylindrical surfaces; the plug or internal gauge is sometimes called the male gauge, and the collar or ring the female gauge; these are very costly gauges, being made of hardened steel; they are only used up to a certain size, because of their weight.

Fig. 248 shows a form of caliper-gauge which can be applied without removing the work from between the centers; one end of this gauge is internal and the other external; it is usual to have different sizes in the one piece, thus a two-inch

LATHE PRACTICE.

outside gauge would have a two-and-one-eighth-inch internal end; in this way the two-inch internal end would be on a

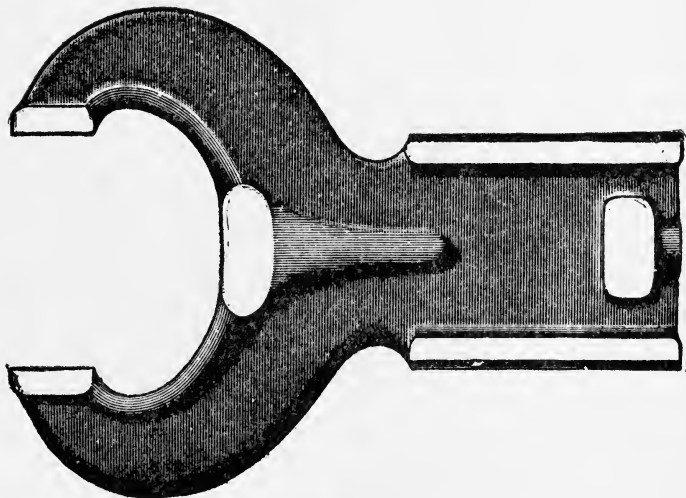

Fig. 248.

separate piece to its mate; thus they can be compared together, which could not be accomplished with the two in one piece.

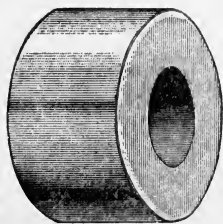

Fig. 249.



Fig. 250.

LATHE PRACTICE.

A *depth-gauge*, as shown in fig. 251, is useful for ascertaining the depth of a hole or recess and for other purposes; it consists of a stock or straight-edge, *A*, in which a graded standard, *B*, slides up or down, being fixed when set to the required depth by the set screw, *C*; a groove, *D*, is also provided so that the rod, *B*, may be used close to the end, as well as in the middle, when convenient.

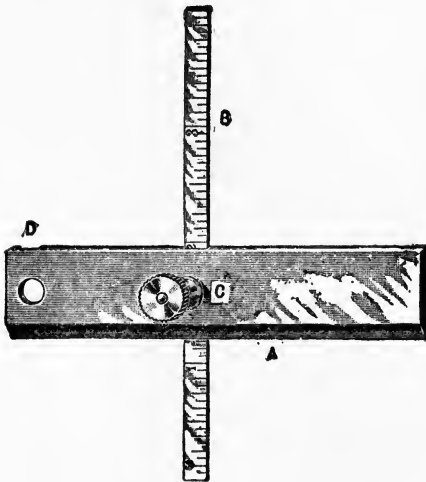

Fig. 251.

NOTE.—A gauge is a standard of measure; an instrument for determining the dimensions, capacity, quantity, force, etc., of anything; hence any standard of comparison or estimation, as a gauge for the thickness of wire, steam-gauge, sheet-metal gauge, vacuum-gauge, water-gauge, recording-gauge, etc.

LATHE PRACTICE.

When a curve, projection or a hollow, is required to be turned on a round piece of work, the exact form should be marked out on a piece of sheet-iron, and a template or gauge should be made by filing away the metal to the line thus marked; the accuracy of the work can then be tested by applying the template from time to time to the work, as shown in fig. 252.

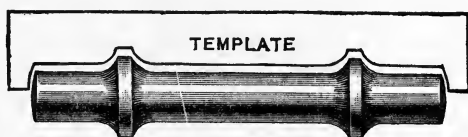

Fig. 252.

Inside and outside templates are made in pairs, when the nature of the work requires it; they are filed to exactly conform to each other, so that the work can be machined accurately, without applying the parts together.

Fig. 253 shows a gauge which every one should make for himself; it is a center gauge which shows the exact angle to which the center points of the lathe should be turned; both



Fig. 253.

center points should be of exactly the same angle, and whenever a center point wears and has to be re-turned, it can by means of this gauge be turned to exactly the same angle as before; for lathe centers an angle of 60° is the one generally used, although in England "Whitworth" adopts an angle of 55° .

CHUCKS AND MANDRELS.

A *chuck* is an attachment to the lathe, designed for holding or gripping the cutting tool or the work itself. A chuck-plate is the large surface plate to which the work may be attached. The utility of a lathe is greatly enhanced by the possession of an assortment of chucks.

A *mandrel* is a cylindrical piece which is driven into hollow work, and holds it while it is turned in the lathe.

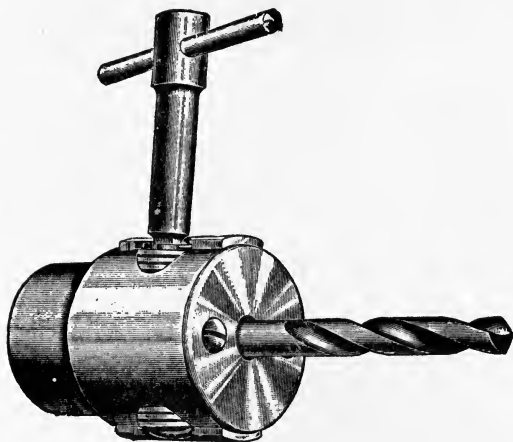

Fig. 254.

A *self-centering chuck*, fig. 254, is one in which the jaws, usually three in number, are opened or closed simultaneously by the turning of one screw only. As each jaw moves through exactly the same distance towards or from the center, it is obvious that a drill or any piece of work fixed between them will be held truly central. For holding twist drills, metal rods, bolts and small castings, these chucks are particularly useful.

CHUCKS AND MANDRELS.

An *independent-jaw chuck* is one in which each jaw (see fig. 256) is moved in or out by its own screw, and works independently of the other jaws. In this device the work is chucked by the moving, either inwards or outwards, of the stepped roughened jaws which, controlled by screws, slide in the blocks; the latter are bolted against the chuck-plate of the lathe, as shown in fig. 255.

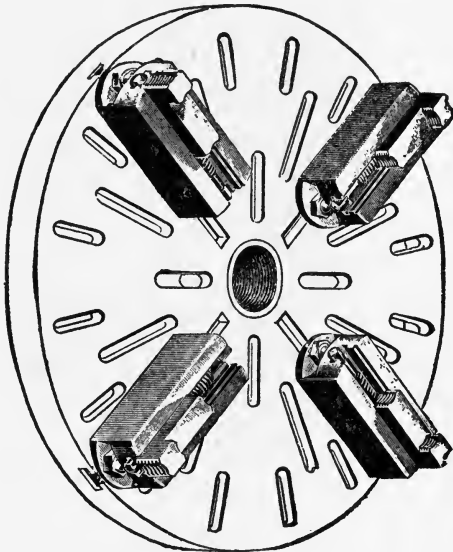

Fig. 255.

A face plate is shown above; this is another view of *J*, in fig. 202, to which reference is made; this is one of very many designs, and when fitted with jaws shown in sketch is called "Cushman's chuck."

In example shown the jaws are independent—simply bolted to the face plate, and are reversible.

CHUCKS AND MANDRELS.

A *dog* is a work-holding device; in shop language "it is a tool which bites like a dog—it holds to its grip—you can't shake it off."

A *dog-chuck* is one containing independent jaws or chucks. Many lathes are supplied by the makers with a four-jaw chuck of this kind. These are, as a rule, much larger and stronger than the self-centering chucks, being of as great a diameter as the lathe will conveniently take. They are very useful for holding heavy castings, such as cylinders, cylin-

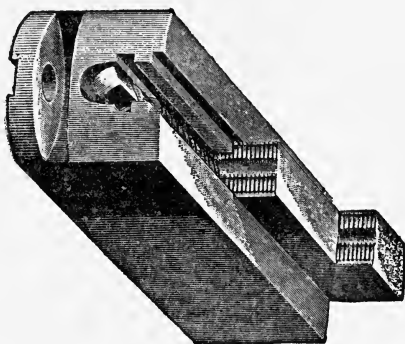

Fig. 256.

der covers, wheels, couplings, pulleys, etc., which have to be bored or faced. Moreover, as each jaw can be moved in or out independently of the others, these chucks enable the work to be held so that, if desired, holes may be bored in out-of-center positions, as in the case of an eccentric for a steam engine.

NOTE.—Work held between the lathe centers is said to run true when a fixed point set to touch its outside rim will have an equal degree of contact all around the circumference; and when the work is cylindrical at any part of the length of the same when it is rotated.

CHUCKS AND MANDRELS.

A modification of this independent-jaw chuck is found useful in chucking irregular work; four "dogs" of the form shown in fig. 257 are used, bolted by the nitted stud to the chuck-plate; the operation of the long set-screw holds the work.

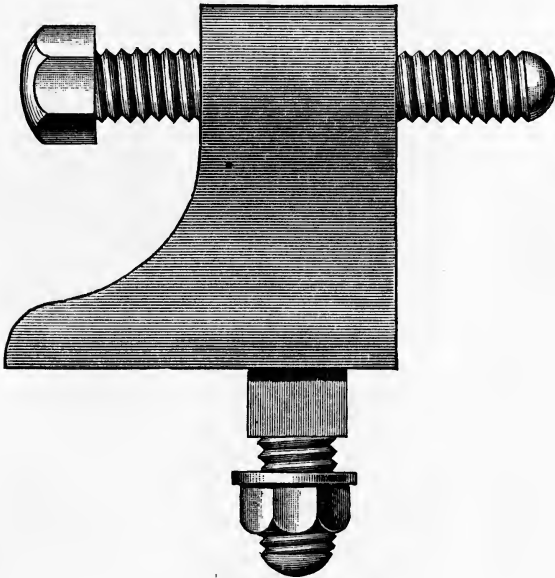

Fig. 257.

A very useful chuck is formed by bolting an angle plate, such as shown in fig. 308, to the face plate, as work which cannot be secured in the other forms of chucks may be bolted to the angle plate, and adjusted to the position desired.

Another form of chuck which depends upon adjustable screws for holding the work is the bell chuck, shown in fig. 258; this is a casting made in the shape of a bell, which at the back is bored and screwed to fit the lathe spindle; the

CHUCKS AND MANDRELS.

work is held by the screws *AAAA*, which are placed at intervals round the bell portion of the casting; these are generally four in number, although sometimes three are used.

In the sketch two sets of screws are shown, one set behind the other; this enables work of considerable length to be adjusted centrally, while the work is more securely held than it could be by one set of screws.

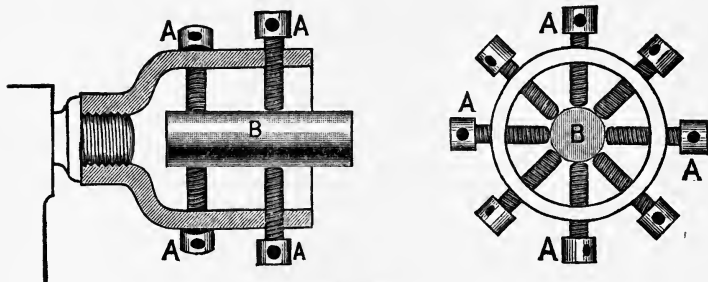

Fig. 258.

When work is heavy at one side, or when an angle plate is used in chucking, it is necessary to bolt a counterbalance on the face plate opposite the heavy part; the distance from the center of the lathe to the heaviest part of the work should be the same distance to the center of the counterbalance, otherwise the work will run "out of true," and will not be round.

NOTE.—The main points to be looked to in construction of a lathe are, that the tail-stock shall fasten to the bed in true line with the counter-line of the live spindle, and that the locking of the dead center spindle shall not cause that spindle to deviate from that true line. The slide-rest must be so fitted to the shears that it will, in traversing along the latter, move parallel to the same lines. As the head and tail-stock of the lathe are firmly bolted to the bed, it follows that the weak point in the connection of the parts lies in the manner of adjusting the carriage, or saddle, as it is sometimes called, to the bed.

CHUCKS AND MANDRELS.

Fig. 259 is a mandrel. This consists of a round turned bar, correctly centered at the ends, and turned to size so as to run perfectly true between the lathe centers. The two ends of the bar are rounded, or turned to a smaller diameter than the body, to suit the carrier and to prevent the blows used in driving the mandrel into work bruising the edges; it is well also to file a flat on each of these end portions, to receive the point of the carrier screw. The central portion of the mandrel is made slightly tapering, so that it may drive tightly into the hole in the work. It is important that the centers at each end be properly drilled and countersunk, to suit the angle of the lathe centers, so that the mandrel may run equally true when end for end, as is occasionally required.

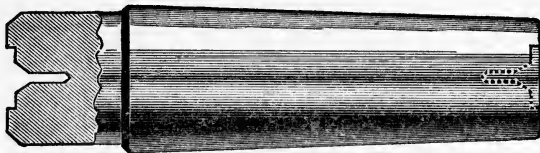

Fig. 259.

Cast steel is the best metal to use for mandrels, as the ends may then be hardened, and so keep the center holes from wearing out of truth. If this plan is adopted, the central portion should be left rather large at first, and should be turned down to size after the ends are hardened, to insure its running perfectly true; failing this, however, mild steel answers very well for most purposes. The length is not very important, provided that they are long enough to allow comfortable room for the slide-rest to be manipulated, but not so long as to bend when being driven into the work, or as to spring when the cutting pressure of the tool is applied.

Mandrels should be treated very carefully if they are required to retain their truth, and they are of little value unless perfectly true.

CHUCKS AND MANDRELS.

The surface of the mandrel which fits the hole in the work should be rubbed with a little oil to prevent it binding too tightly, and the mandrel may then be driven in with a hammer. It is important that the blows of the hammer should not bruise the end of the mandrel, and so spoil the center hole; this may be avoided by using either a lead or copper hammer, or by placing a piece of brass or copper between the hammer and the mandrel end to receive the blow.

When it is required to remove the mandrel after the turning has been done, it may be driven out from the opposite end in a similar way, but a piece of lead should be placed under the work to prevent any injury to the finished surface. If a

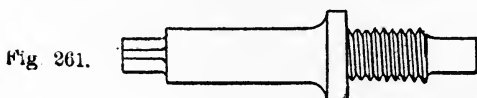
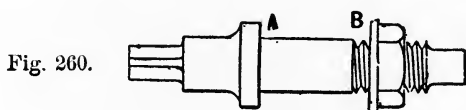

mandrel is being driven in or out of a pulley with light arms, or any other job liable to be damaged by the blows, care should be taken to support it close round the hole through which the mandrel passes, so as not to allow the strain of the blows to come on the fragile parts.

Fig. 260 shows another type of mandrel on which the work is held tight, not by being driven on the mandrel, but by being clamped between the shoulder, *A*, and the adjustable nut and washer, *B*. Fig. 261 shows a mandrel which is useful for holding work through which a threaded hole passes, or for holding nuts for facing and chamfering. If the threaded por-

LATHE PRACTICE.

tion of the mandrel be made sufficiently long, the work may be locked in position by a nut screwed up against it on the outside; though this is not usually necessary, as the work can be screwed hard up against the mandrel shoulder, and the cutting pressure only tends to tighten it. The mandrel shoulders in the types shown in figs. 260 and 261 should be accurately faced up true to insure good work.

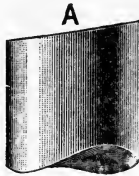

Fig. 262.

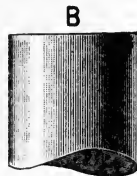

Fig. 263.

CENTERING FOR THE LATHE.

The operation of preparing a piece of iron or steel for running properly between the lathe-centers requires a provision in the objects to be rotated to receive the center-points of the lathe, *i. e.*, the live and dead centers; these are conical holes, made to fit exactly the lathe "points" or centers.

In "centering," the following method should be adopted: Supposing the work to be centered is a round piece cut off a bar, the first thing is to file both ends practically square, as shown in fig. 263; on no account should the ends be left as at *A*, fig. 262; then fix the piece end up in the vise, and rub the top end over with a piece of chalk; next take a pair of odd leg

LATHE PRACTICE.

calipers, open them approximately half the diameter of the bar to be centered, and scribe or mark from opposite sides; these markings will act as a guide to the center-punch in pricking for the center hole.



Fig. 264.

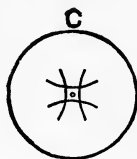

Fig. 265.

A *center-square* is shown in fig. 266; this instrument is made of sheet steel, about one-quarter inch thick, forming a right angle, having a longer blade riveted to it, in such a position that one edge exactly divides the right angle into two equal angles of 45° each; this device is used as shown; the dotted circles represent the ends of any size of circles.

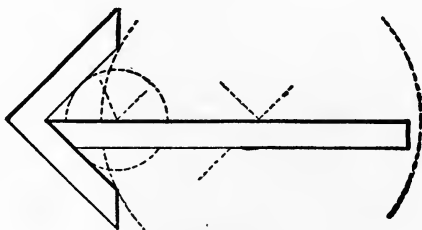

Fig. 266.

The work having been roughly centered up, it should be placed rather loosely between the centers without a carrier, and lightly spun round by the fingers. It will at once be apparent whether the centering has been correctly done or not. If the work runs out of truth, a piece of chalk should be held close to it while it is being spun round, so as to touch the side which runs farthest out from the center.

LATHE PRACTICE.

The work should then be fixed again in the vise, and the center-pop drawn over by careful use of the center-punch towards the side marked by the chalk. The work should again be placed in the lathe and the process repeated until the desired accuracy is obtained. If, however, the center has been carefully marked out with the calipers or scribing block as already indicated, it will need little or no correction in this way.

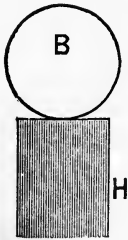

Fig. 267.

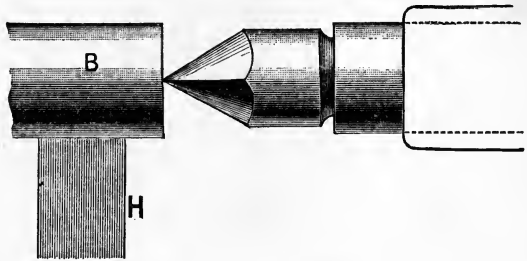

Fig. 268.

In rapidly and accurately centering a number of pieces of work, the "square-center" is of much service. This is an ordinary lathe-center with four flats filed on the point, so as to form cutting edges, see fig. 268; it should be hardened and tempered to a straw color, and is used as follows:

The work, after being roughly centered with a punch, the marking out process not being necessary, is fitted with a carrier and placed between the centers, the ordinary dead center of the lathe being replaced by the square center; a square end bar, *H*, is fixed in the slide-rest, and is then gradually brought to bear against the work, *B*, while the latter is running round as in fig. 268; at the same time the square-center is fed up against the work, and as the latter is being forced to run true by the pressure of the bar in the slide-rest, a correct center hole is cut.

Fig. 267 is an end view showing work, *B*, and square bar, *H*.

CENTERING FOR LATHE.

Some prefer to use a fork-ended bar to press against the work, as keeping it under better control, but with ordinary care the plain end is quite sufficient.

The work having been correctly centered, the next process

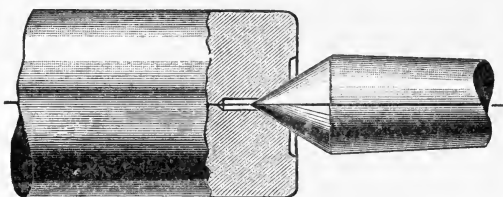

Fig. 269.

is to drill at each center "pop" a small hole about one-sixteenth inch diameter; this hole should be larger or smaller than the size mentioned, according to the work, and should

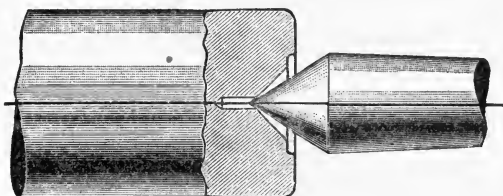

Fig. 270.

not be more than one-fourth inch deep; the object of this hole is to allow the extreme point of the lathe center to clear at the bottom; next, each of these holes should be countersunk

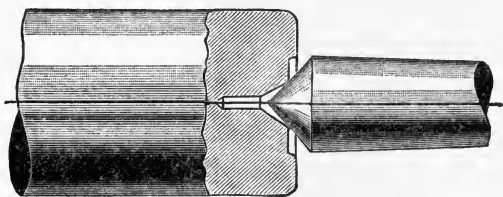

Fig. 271.

to the exact angle of the lathe center, say 60° , as shown in fig. 269, which represents the centering correctly done, and the work bearing evenly on the lathe center.

CENTERING FOR LATHE.

Fig. 270 shows the countersink at a greater angle than the lathe center; this is not right, and would soon wear untrue. Fig. 271 is too small an angle, and should not be permitted; it will cause heating of the center and will wear out of truth.

The best way to accomplish this is by means of a countersunk center bit to fit in the lathe mandrel; it is simply an ordinary lathe center filed away to slightly less than half its diameter, and then hardened and tempered; an ordinary countersunk drill will answer the purpose.

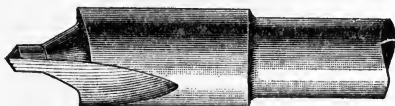

Fig. 272.

Fig. 272 shows a useful combined center-drill and countersink, which may be procured of tool dealers at a trifling cost; it fits in the chuck, and will both drill and countersink the center-hole at one operation.

NOTE.—Very many machinists when centering up a piece of work simply smooth up the end with a file and make a “center-pop” with a hammer and center-punch as near the middle of each end as they think correct. This method of procedure may give rise to one or more of the following troubles when the job is being turned: (1) The work may be a good deal out of truth when first starting turning, which makes the first cut very uneven in character, or prevents the work from cleaning up to the proper diameter; (2) the work may run out of truth after being partially turned; (3) the work may not run true when changed end for end between centers; (4) the turned portions may be oval, instead of being truly round.

The first of these troubles is obviously due to the “center-pop” being incorrectly placed; the second will be due to the fact that the point of the lathe center rests at the bottom of the “center-pop,” and is not supported at the sides, thus not having a proper bearing, and consequently being free to shift about as the cutting pressure is applied; the third trouble will arise if the “center-pop” at the dead center wears, as above suggested; if the fourth trouble is found to exist, the cause will be because the end of the work has not been filed at right angles to the axis before centering up, thus causing the lathe center to have more bearing on one side than the other.

DRIVING WORK BETWEEN LATHE CENTERS.

Before the work is put between the centers, observe whether the live center runs true in its place; if not, take it out and replace it again; if it cannot be got to run true, it must be trued up in its place.

The centers for turning straight work must be "in line"; they can be set in line by sliding up the tail-stock and bringing the centers together, and adjusting the dead center; now, clean the ways and slides, oil the bearings thoroughly, and the lathe is ready for service.

When a piece of work has been centered and placed in the lathe ready for turning, it is obvious that some sort of contact

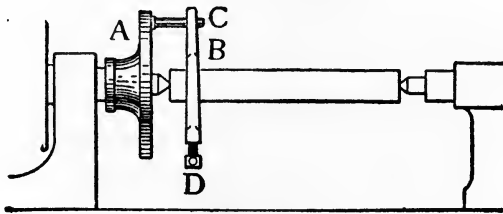

Fig. 273.

or connection must be established between the work and the lathe mandrel, so that the latter can "drive" or carry round the former as it revolves. This connection is usually provided by means of the face-plate or "driver-plate" of the lathe, and a "carrier" or "dog" on the work.

Such an arrangement is shown in fig. 273.

Fig. 274 is a perspective view looking down on a lathe in operation.

Fig. 275 shows an end view of a lathe with the cutting tool in operation on a round shaft; the cutting tool is held firmly in a tool-post in an upper sliding rest, as shown in sketch; there is a lower slide-rest with a travel at right angles

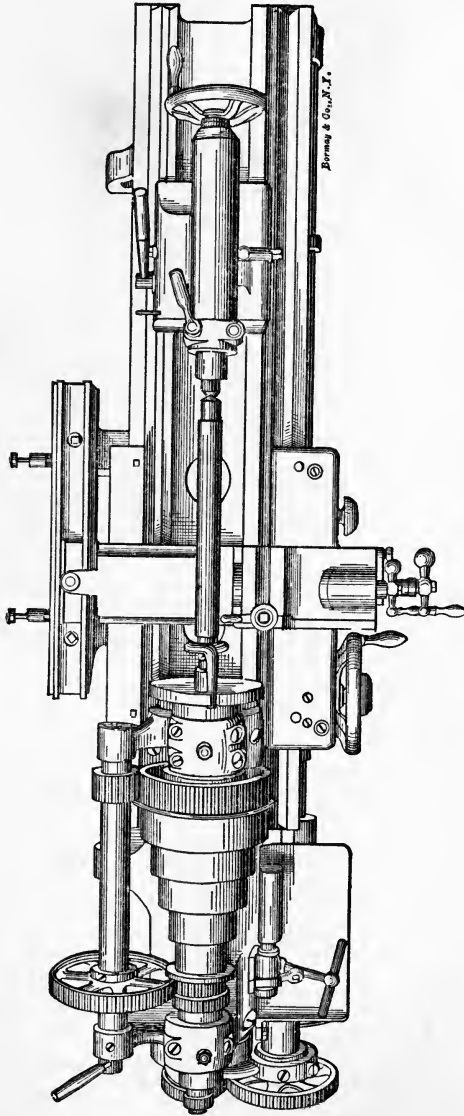

Fig. 274. See page 805.

DRIVING WORK BETWEEN LATHE CENTERS.

to the upper one, which is attached or bolted to the carriage, and has V-grooves on its under side, by which it slides on the parallel V-ribs on the bed. The construction of the shears and bed of the lathe is shown in section.

An example of an "elevating-rest" is shown in fig. 208;

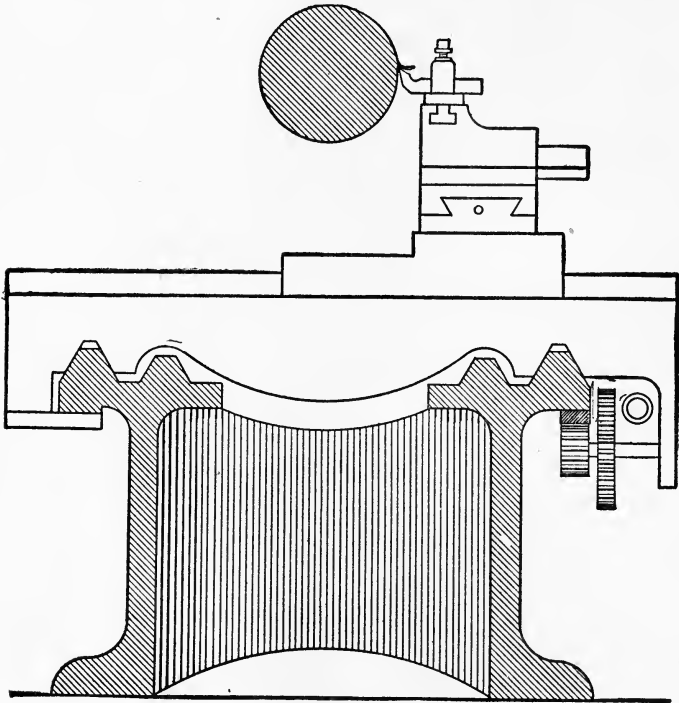

Fig. 275.

the object aimed at in this form or addition to the carriage of a lathe is to raise or lower the end of the rest by a screw, and thus to regulate the cutting point of the tool to the height required by the work being operated upon.

Fig. 273 shows a side view of the work between the lathe centers; *A* is simply a small circular plate which screws on to the live spindle, and has a driving pin, *C*, screwed or riveted into it at right angles near its outer edge. The car-

DRIVING WORK BETWEEN LATHE CENTERS.

rier or dog, *B*, is firmly fastened to the end of the piece of work to be turned by means of the set screw, *D*. It will be seen that the pin, *C*, catches the projecting tail of the carrier, and thus drives the work round as the mandrel revolves. The shape of the "dog" shown will be more clearly seen on referring to page 6, in the beginning of this book; a modification of the dog is often used, see fig. 275a; the bent tail is used in direct connection with the face-plate *A* (see fig. 273), the pin, *C*, being dispensed with.

The point of the carrier screw should be slightly chamfered off, and should be hardened to prevent it burring over by the

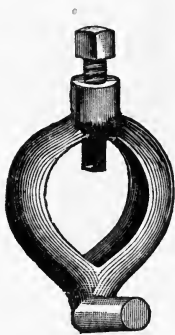

Fig. 275a.

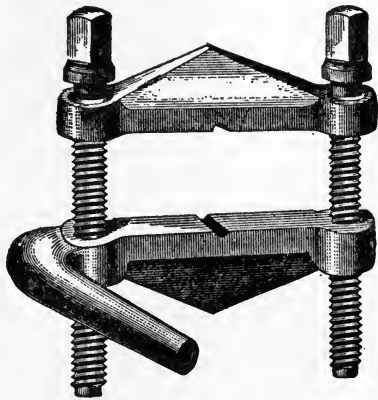

Fig. 276.

constant tightening down. Carriers such as shown in this sketch should be of various sizes, and, of course, each size of carrier will accommodate different sizes of work within its limits.

When turning long, thin shafts or spindles, the pressure of the driving pin, being exerted only at one end of the carrier, tends to bend the work. This may be overcome by the use of a face-plate having two driving pins, one pressing at each end of the carrier.

For very small and also for large work, the form of carrier described has its disadvantages; thus, not only is it difficult

DRIVING WORK BETWEEN LATHE CENTERS.

to properly grip very small work, but the carrier is heavy and unwieldy in proportion to the size of the work; in such cases a pair of wrought or malleable cast iron clips, as shown in fig. 276, are useful; the work is gripped in the V-shaped notches, pressure being applied by tightening the screws, the holes in the upper bar in the sketch being plain clearing holes, the screws being tapped into the corresponding holes in the lower bar; the bars should be made of wrought iron or mild steel, and of a size in proportion to the work. One of the straps should be provided with a projection or horn to act as a driver.

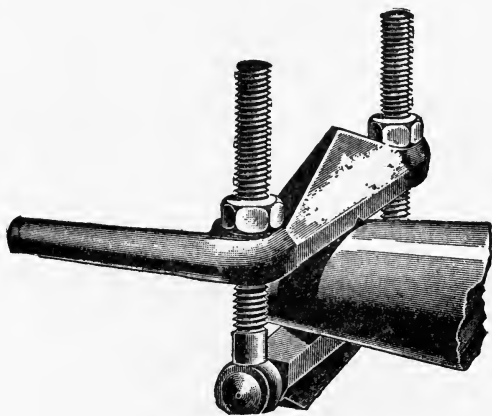

Fig. 277.

Fig. 277 shows an improvement on the above; the tightening screws are pivoted to one of the clamps, and the pressure is applied by the nuts, as shown.

The advantage of this arrangement is that a taper cone or irregular piece of work can be held with the jaws, which accommodate themselves to the work, which cannot be done by the arrangement in fig. 276.

For light work of a large diameter which has not to be subject to a very heavy cut, an ordinary collar with a set screw makes a convenient form of carrier, as the driving is

DRIVING WORK BETWEEN LATHE CENTERS.

done through the set screw, which has all the strain; this is not suited for heavy work, but for light jobs it is frequently of service.

When a large job has to be driven between centers, which though small enough to easily clear the lathe bed will not

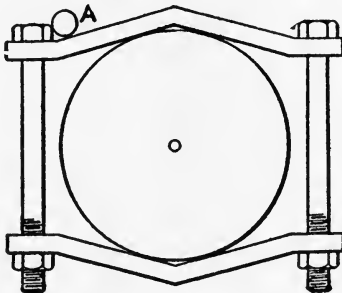

Fig. 278.



Fig. 279.

admit of much projection of the carrier, the usual device is a pair of "straps," as they are termed, as shown in fig. 278.

The driving pin of the chuck-plate will then fit against the strap next one of the bolt heads, as shown at *A*. It will probably be found that the ordinary chuck-plate is too small for a job

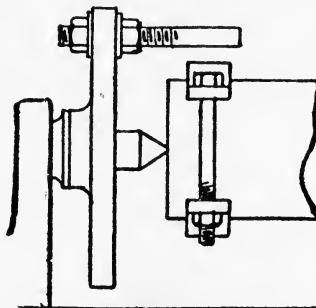

Fig. 280.

of this size, in which case one must be improvised by using the face plate. This can be done by inserting an ordinary bolt through one of the slots, or holes, in the face plate, and fixing it up in place with nuts and washers, as in fig. 280. The head of the bolt should be previously cut off with a hack-

DRIVING WORK BETWEEN LATHE CENTERS.

saw, so that the body of the bolt may engage directly against the strap.

A neat method of driving, for bolts with hexagonal or square heads, is shown in fig. 281. An iron plate, *B*, bent as shown, is fastened to the face-plate, *A*, by the bolt *C*. The lower end of the plate is cut out to fit over the head of the bolt, as shown in the end view, fig. 282.

It often happens that the screwed part of a bolt, or that finished work, has to be held by a carrier, while the operation

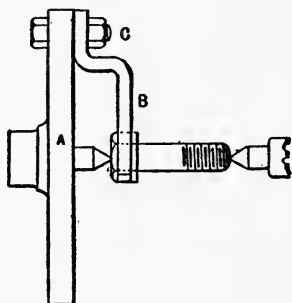

Fig. 281.

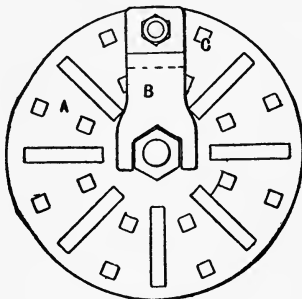

Fig. 282.

is performed on the other end, then a piece of sheet-brass or copper should be bent into a ring, and placed between the end of the screw in the dog and the work, to prevent damage to the latter.

TURNING WORK BETWEEN CENTERS.

Taking, as a practical example in lathe turning, a plain wrist-pin suitable for an engine cross-head, as shown in fig. 283, the operator-machinist should proceed as follows: He

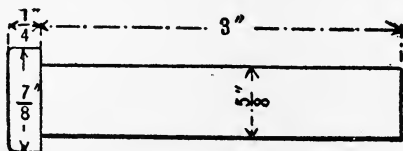

Fig. 283.

TURNING WORK BETWEEN CENTERS.

should select a piece of mild steel or wrought iron somewhat longer than the finished wrist-pin required; the diameter of the piece of steel chosen should also be slightly larger than the diameter of the head of the wrist-pin; as the latter is seven-eighths inch, a piece of steel 1 inch in diameter should be used.

The first operation is to square up the ends with a file, and mark off, drill, and countersink the center holes as described on page 269; this done, a suitable carrier should be affixed to one end of the piece of steel, which may then be placed between the lathe centers. A drop of oil should be applied to the point of the dead headstock center, and the latter

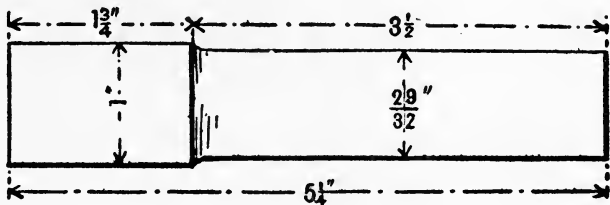

Fig. 284.

should then be tightened up until the work can be easily moved round with the fingers without there being any vibration. A front turning tool, preferably of the swan-neck form, shown in fig. 217, should then be fixed in the slide-rest, and the lathe started.

Now, take a cut along the work for a distance of about three and one-half inches, as shown in fig. 284, that is about one-fourth inch longer than the wrist-pin is to be when finished; this cut should be deep enough to reduce the diameter of the

NOTE.—If economy in material is not important, it will be found convenient, in making a pin of the dimensions shown, to choose a margin of one and three-fourths inches, in the length. This extra length will allow ample space between the centers to manipulate the slide-rest without interfering with the carrier, and will avoid reversing the work, end for end, in order to reach the various portions of the job with the tools.

TURNING WORK BETWEEN CENTERS.

work to one-thirty-second over seven-eighths inch, thus leaving enough material to enable a light finishing cut to be afterwards taken over the portion forming the head of the wrist-pin; then run the tool back to the end again and take another cut along for a distance of three and one-eighth inches, as shown in sketch—fig. 285; this cut should be repeated until



Fig. 285.

the diameter of this part of the work is reduced to about one-thirty-second inch over five-eighths inch, the finished size. A light finishing cut, with plenty of soap and water applied to the cutting edge of the tool, should then be taken, to reduce it to an exact five-eighths inch diameter. The head of the piece may then also be finished to its exact diameter. The front tool should now be removed from the slide-rest, and a right-hand, knife-edge side-tool, fig. 233, inserted, with which the shoulder "a" in sketch, fig. 286, may be cut out, square.

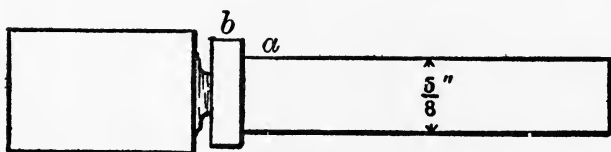

Fig. 286.

Now, substitute a parting tool, fig. 235, for the side-tool, and cut down the head of the wrist-pin, as shown at "b" to its correct thickness, one-fourth inch; this cut should not be taken too deep at first, as it will weaken the work, and may cause it to fracture.

NOTE.—When finishing wrought iron or steel plenty of soap and water may well be applied to the tool, as it imparts a bright, smooth finish to the work, aside from its cooling property.

TURNING WORK BETWEEN CENTERS.

Now, round the head of the piece at the corner, according to the drawing, fig. 283; a straight tool will do this well; now, use the right-hand side-tool to cut the body of the pin to its exact length, three inches, as in drawing, fig. 287; a small portion of metal should be left round the center hole at *c*, whereby to support the work until finished.

The parting tool is now again brought into use, and the metal at "*d*," see fig. 287, cut down until it almost breaks off; the work may then be removed from the lathe, and the piece is broken away from, or cut off, with a hacksaw; the portions of metal at "*c*" and "*d*" can be easily removed with a file, or, as is more usual, the work is placed in a self-centering chuck, and finished off at the ends with a side tool.

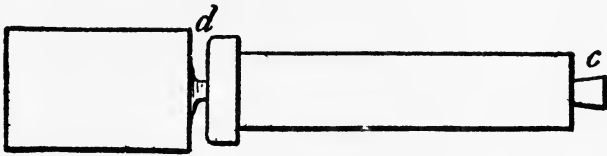

Fig. 287.

When turning long shafts and spindles, much trouble will be saved if the work is properly centered and straightened before starting to turn it. If a long piece of iron or steel be temporarily centered, and placed in the lathe, it will, in most cases, be found to run out of truth in different places; should it run out of truth equally throughout its length, it is obvious that the reason is that the center holes are not correctly placed at the ends. In some cases, however, the ends may run true, but the shaft may still be out of truth at other places; this is because it is bent, and therefore it will be necessary to straighten it before commencing the actual turning.

NOTE.—The object of cutting the work back at "*c*" in this case is to avoid retaining the center hole in the end of the pin; in work of this kind it would look unfinished if the center marks appeared.

TURNING WORK BETWEEN CENTERS.

When dealing with such a shaft the first thing is to center the ends so that they may run true, then to ascertain which way the shaft is bent.

Now, take a piece of chalk between the fingers of the right hand and hold it steady, close to the surface of the shaft, the shaft being meanwhile spun round between the centers by the left hand, or if too heavy for the hand rotate it, by a carrier or driver in the ordinary way; if held close enough, as the shaft revolves the chalk will touch that side of the shaft which is farthest away from the line of centers, thus indicating that the shaft is bent outwards at that point.

Two such bends are shown, slightly exaggerated, at *A* and *B* in the shaft drawn in fig. 288. These points being marked, the shaft should be taken out of the lathe and laid over two

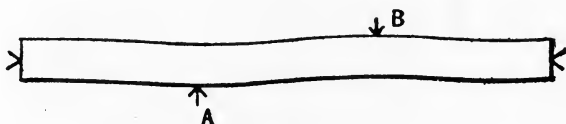

Fig. 288.

blocks of iron, placed a few inches apart, one of the chalk marks on the shaft being uppermost and over the space between the blocks. Two or three smart blows on this mark from a hammer will tend to straighten this particular bend, and, the other bends having been similarly treated, the shaft may be replaced between centers and again tested with the chalk. Very few trials of this kind are generally sufficient to correct the inaccuracies, and the turning may then be proceeded with.

A long thin shaft or spindle will bend or spring considerably under the pressure of the cutting tool unless it be provided with some other support in addition to the lathe centers. In self-acting lathes, where the slide-rest is carried on a saddle which slides along the bed, a "follow rest," as illustrated in fig. 289, is usually provided. This consists of a pillar fastened

NOTE.—Belt-driven, screw and hydraulic devices are especially designed and used with great efficiency for straightening shafting and round iron.

TURNING WORK BETWEEN CENTERS.

to the lathe saddle, and carrying in a recess two hardwood or gun-metal blocks, *CC*, which are bored out to suit the diameter of the shaft being turned. These blocks are fastened in place by set screws and cap, *D*.

Fig. 53 shows an enlarged view of the plan of a "steady rest," as described, and fig. 54 is a side view of the same device.

It will be noticed that the shaft revolves in V-shape bearing, as shown in fig. 53; this shape has an advantage over a round hole, because the V-bearing can be adjusted to accommodate several different sizes of shafts.

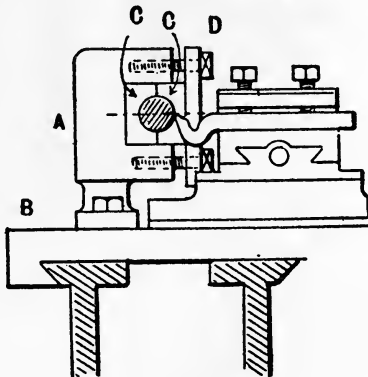

Fig. 289.

To use this appliance, the end of the shaft is first turned to the right diameter for a distance of two or three inches. The turned portion is then passed through the blocks, *CC*, and is also supported by the back center in the usual way. As the saddle carrying the turning tool travels along the lathe bed, so this bearing, as it really is, travels with it, and thus forms a constant support, immediately behind (*i.e.*, to the right-hand side of) the cutting tool.

NOTE.—It is frequently desirable to leave the center holes in the work, as at some future time it may be necessary to again put the work in the lathe to effect a repair or an alteration. It is very usual to leave the centers in such work as three throw-cranks, etc. As a guide for re-turning them, in some work of this class it would be very difficult to re-center the work should the original centers be removed.

TURNING WORK BETWEEN CENTERS.

The turning of crank pins, on crank shafts, presents more difficulty than the ordinary run of lathe work; in fig. 290, to turn a crank pin, *A*, in the lathe, it is obvious that it should revolve in line with the lathe centers, *BB*; provision for this is made by fixing plates, *cc*, on the ends of the crank shaft, and drilling center holes in the plates in line with the center of the crank pin to be turned.

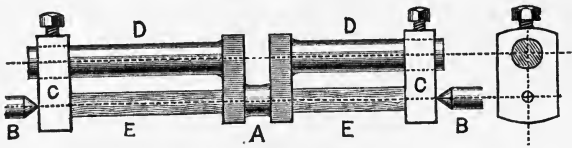

Fig. 290.

The main portions of the crank shaft, *DD*, must first be turned, though not necessarily to their finished size; the plates, *cc*, must be bored out to be a tight fit on the ends of the crank shafts to which they are each further secured by a set-screw; the crank shaft is then laid on a surface plate or on the lathe bed, which will answer this purpose very well. If the sides of the crank webs have been truly planed, the crank may rest on these; but if not, it should be supported on the portions already turned, in the V-blocks, *AA*, as shown in fig. 291. The crank should be placed so that the webs lie in a horizontal position. A scribing block, *B*, with the scriber

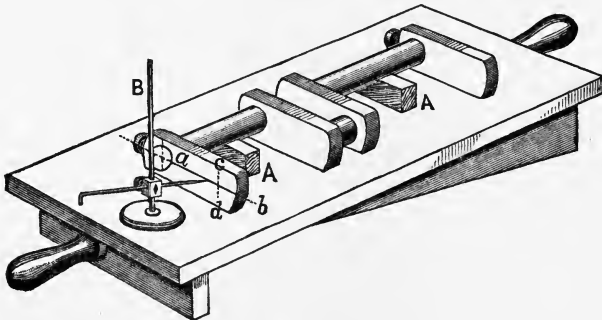

Fig. 291.

TURNING WORK BETWEEN CENTERS.

set exactly to the height of the center of the crank shaft, should then be used to make a horizontal center line, $a b$, across the outside face of each end plate. Care should be taken that the crank remains unmoved till this center line has been marked at each end.

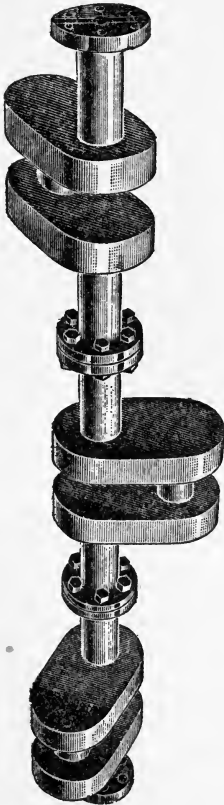

Fig. 292.

It would be well to test the height of the centers at each end of the crank shaft with the point of the scriber beforehand, to make sure that the shaft is perfectly level. When both the center lines, $a b$, have been thus marked, the exact "throw" of the crank should be taken in a pair of compasses, and an arc, $c d$, described from the center hole in the crank end. The point of intersection of the lines, $a b$ and $c d$, will then give the exact centers at each end from which the crank pin is to be turned. Center holes should be drilled and countersunk in the usual way at these points. The crank shaft may then be mounted in the lathe on these centers, and the crank pin turned.

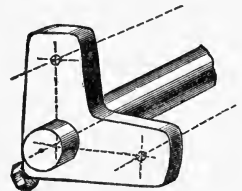

Fig. 293.

When the crank is a double one, with one crank in advance of the other, or at an angle with it, the plates are made with angular arms, as fig. 293.

A three-throw crank will require end plates with three arms placed at the angle of 120° apart.

TURNING WORK BETWEEN CENTERS.

When crank shafts are being turned between centers they are apt to spring under the pressure of the centers and of the cutting tool; this may be overcome by wedging in stout pieces of hardwood, *EE*, fig. 290, between the end plates and the faces of the crank webs. Large cranks, as a rule, are strong enough to be turned without extra supports.

In turning crank shafts the work as a whole is very much out of balance, and will require a counter balance weight on the opposite side of the driving plate of the lathe, and the crank itself must be prevented from rotating unevenly or jerking round between the centers by driving the end plate, which serves also as a carrier between two driving pins, one of which does the actual driving, and the other supports the weight when the crank overbalances in coming round.

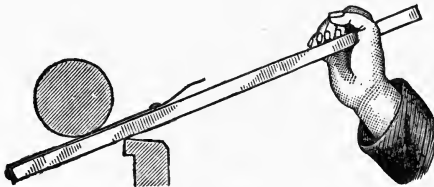

Fig. 294.

The surface of a fly-wheel, or pulley, may be finished off by using a hand scraper, or a "smooth" flat file. In the latter case, the speed of the lathe should not be too great, or the teeth of the file will be worn away very rapidly. Although the lathe may only be making a comparatively few number of revolutions per minute, the circumferential speed of the fly-wheel or pulley being turned may be considerable on account of its large diameter. On the other hand, spindles and other jobs of small diameter should be run at a high speed when being filed in the lathe, or there will be a danger of the file taking more off the work at one part of its circumference than at another, and thus spoil the roundness of the work; the final polish is usually obtained with a stick and a piece of emery

TURNING WORK BETWEEN CENTERS.

cloth, used as shown in fig. 294. Here the stick, *A*, is supported on the tool rest, *B*, and presses the emery cloth, *C*, against the under side of the work, the leverage thus secured making it easy to apply sufficient pressure while the work revolves at a high speed. A coarse piece of emery cloth should be used to commence with, and this should be changed for a finer piece as soon as the file or tool marks are removed; for polishing wrought iron, cast iron, or steel, plenty of oil should be applied to the emery cloth; brass and gun metal are best polished dry. Very fine emery powder is sometimes used to give an exceptionally high degree of polish, but it is rarely necessary; a fine finish on brass or gun metal may be obtained by using polishing paste, spread over a piece of cotton waste; this should be held against the work while it is running at a considerable speed.

LATHE SPEED.

The speed at which the lathe should run when turning must, of course, vary with the size of the work, the depth of the cut and the nature of the metal.

Cast iron and cast steel require the slowest speeds; wrought iron and mild steel require medium speeds, and brass and gun metal the highest speeds.

If the work is run at too high a speed it will unduly heat the point of the cutting tool, and, by thus destroying its temper, will make it too soft to cut; it is better practice to take moderately heavy cuts, at moderate speeds, than to take light cuts at high speeds or heavy cuts at very slow speeds.

Mild steel and wrought iron are best turned with the aid of a plentiful supply of soapy water, especially when taking finishing cuts. Cast iron, brass and gun metal should be turned dry. Oil is very useful as a lubricant for turning cast steel, while turpentine is a great help when using spring tools

LATHE SPEED.

with **broad** cutting edges. When turning castings of any description, the first cut should get right under the skin of the casting all round. If this is not done, the hard surface of the skin, and the sand which is always present therein, will speedily spoil the cutting edge of the tool, and necessitate its being re-ground. An old file may sometimes be used with advantage to remove the skin of the casting at the place where the tool starts its cut.

For the above reason special care should be taken, when boring castings, to get the hole as central in relation to the outer circumference as is allowable, so as to have the job run **fairly true when** mounted on a mandrel for turning. Their largest diameter on a job is usually turned first, and the smallest part last. If the diameter of the smallest part be turned down first, the strength of the job is reduced, and it is not so well able to stand the strain which results when the larger portions are being turned. It is easier to turn a cylindrical piece of work to exactly fit a hole, than it is to bore a hole to exactly fit a turned piece of work.

Where possible, therefore, the hole should be bored first, and the pin or spindle turned to fit afterwards. Always keep the loose headstock center well oiled, and always have both lathe centers turned to the same angle. When placing a piece of work between centers, see that the center hole and the center point are both free from grit or dirt; otherwise the work will not run true; the center in the mandrel revolves with the work; it therefore has no wear, and need not be hardened; each center should always be kept to its own end of the lathe, and always put it in in the same position. One center-pop should be placed on the mandrel end, and another on the body of the center; by taking care that these marks are brought opposite one another when the center is inserted, the right position will be insured. A similar precaution should be observed with the tail stock or dead center

CHUCK AND FACE PLATE WORK.

The face plate and the various chucks are largely used for holding jobs which have to be drilled or bored in the lathe; but in addition to this it frequently happens that a piece of turning has to be done which cannot conveniently be accomplished between centers, and which, therefore, has to be mounted on the face plate or in a chuck.

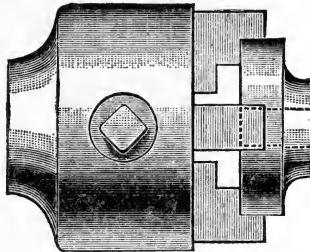

Fig. 295.

Fig. 295 shows the method of holding a small casting in the jaws of a self-centering chuck, upon which boring or end facing work has to be executed. Fig. 296 shows a similar chuck holding a ring or collar which has to be turned on the outside; in this latter case the position of the jaws is reversed, and the work is gripped from the inside.

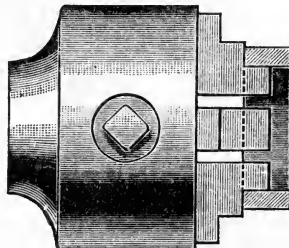

Fig. 296.

Fig. 297 shows a gland for the stuffing-box of a steam engine cylinder, held in a four-jaw dog-chuck.

CHUCK AND FACE PLATE WORK.

Fig. 299 is a front view, and fig. 300 is a side view, which shows a simple example of a face plate job; it represents a cylinder, *A*, fastened to a face plate, ready for bor-

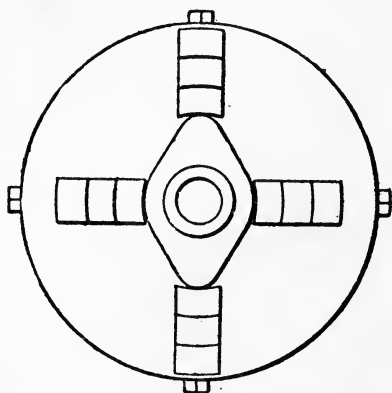

Fig. 297.

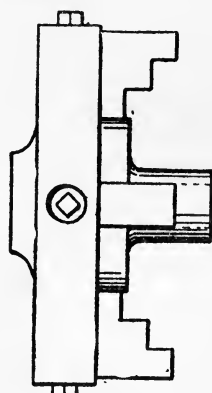

Fig. 298.

ing; *BB* are clamps, or clamping plates, *cc* are packing pieces which support the outer ends of these plates; these packing pieces should not be placed too close to the bolts, as the pressure of the screws will then act on the packing pieces

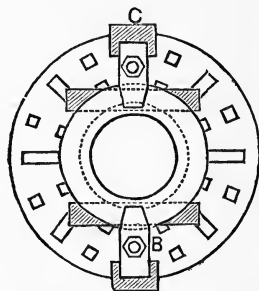

Fig. 299.

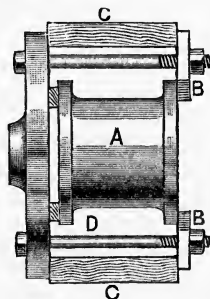

Fig. 300.

instead of on the cylinder, in which event it would be liable to slip and alter its position.

It will be observed that the cylinder itself is resting on two

NOTE.—The lathe bed must not be used for an anvil, nor yet as a resting place for tools, spanners, chucks, etc.; have a shelf, a cupboard, and a tool rack for this purpose. A good machinist never ill-treats his lathe, and always keeps it tidy, clean, and well adjusted.

CHUCK AND FACE PLATE WORK.

other packing strips, *DD*, which are used in order to keep the cylinder a short distance away from the surface of the face plate, so as to provide clearance for the boring tool as it comes through.

It is important that the packing strips used for this purpose should have parallel faces, and should be of exactly equal thickness, or otherwise they will throw the work out of truth.

When arranging the clamping plates in a job of this kind, care should be taken that they rest on a solid portion of the work, and not on the unsupported portions of the flanges, or the latter may be fractured by the pressure when tightening up.

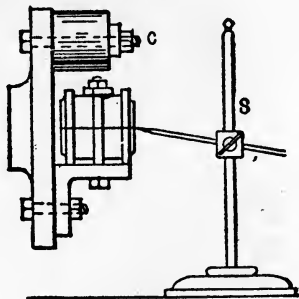

Fig. 301.

When work has to be bored out to a marked line, its position in the chuck may be accurately tested by means of a scribing block resting on the lathe bed, as shown in fig. 301. Another and equally good plan is to fix a scriber in the slide-rest and adjust the work in the chuck until the marked line which has to be worked to, touches the scriber at every point, as the chuck is slowly turned round by hand.

Fig. 302 to fig. 307 illustrates the method of boring and turning a small V-groove sheave from a solid piece of metal held in a chuck; sketch *A* shows the end of the metal to be used; *B* shows largest diameter turned; at *C* the diameter of the boss is roughed out and the hole bored; *D* shows the V-groove roughed out, and *E* the sheave cut off by means

CHUCK AND FACE PLATE WORK.

of the parting tool, and *F* shows it mounted on a mandrel for taking a light finishing cut.

Figs. 308 and 309 illustrate the use of an angle plate for mounting jobs for boring, which cannot conveniently be

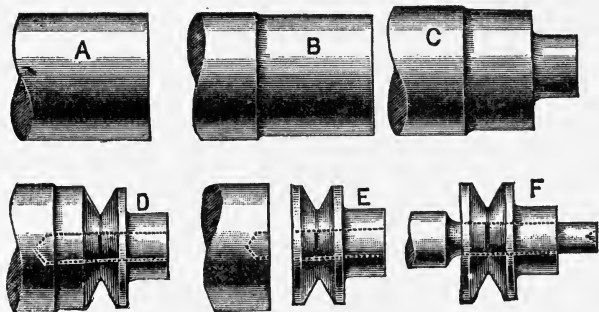

Figs. 302—307.

clamped to the face plate in the usual way. The job to be bored and faced is bolted to the horizontal surface of the angle plate, and the latter is bolted to the face plate; work of this description requires a counterbalance, which is shown in the figure bolted to the face plate.

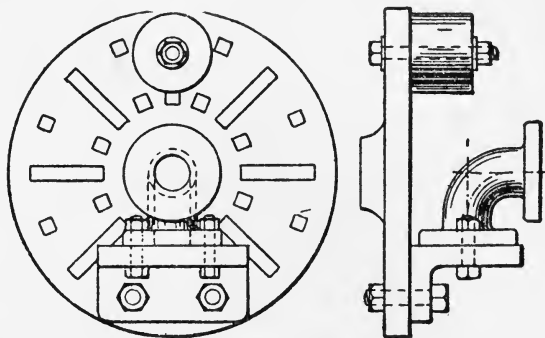

Figs. 308—309.

DRILLING AND BORING IN THE LATHE.

The term "drilling" is usually applied to the making of a hole in solid metal by a drill which forms an aperture of the desired diameter at one operation.

The process of "boring" a hole is generally effected by the action of a single-pointed tool, the successive cuts of which gradually enlarge the opening until the desired diameter is reached.

Small holes are generally made by drilling, while large holes are usually produced by boring. To drill a large hole not only requires considerable driving power, but involves the removal of a considerable quantity of metal; whereas, if the method of boring is adopted, a rough hole may be "cored" through the casting when the latter is made in the foundry, and this can be subsequently enlarged to the required size by the application of a boring tool. Thus, if a certain size bore were required in a steam engine cylinder, the casting will be "cored" out a little smaller than the required size, and will be finished by boring, effecting a saving both in labor and material over the alternative method of drilling the hole out of the solid metal. Another advantage of boring is that a hole can be made to any odd size or to exactly fit any piece of turned work, without the necessity of making a special tool for the job.

In discussing the actual operations and appliances involved, drilling will be dealt with first. For small holes, say up to one inch diameter, twist drills are the best to use, as they can be depended upon to produce accurate and smooth holes, exactly to size. The usual method is to fasten the drill in a self-centering drill chuck, and to feed the work up against the drill by means of the back-center of the lathe or the sliding carriage.

DRILLING AND BORING IN THE LATHE.

The exact place for the hole should be marked off on the work, and a heavy center-pop should be made, so as to guide the point of the drill at starting; with large holes, a circle the size of the hole to be drilled should be marked with compasses, and four center-pops should be made at opposite points on the line; these are necessary to act as guides in case the line gets effaced; a start is then made, but before the point of the drill has fully entered the metal, an examination must be made to see if it is cutting truly with the circle marked out; if it is so doing the work may be proceeded with and the hole drilled.

It frequently happens, however, that the drill will have run slightly to one side; to remedy this a narrow groove must be cut down one side of the hole; this may be done with a narrow diamond-pointed chisel, and the groove should be made on the side towards which the hole requires to go, to be in the correct position; the drill may then be applied again, when the effect of the groove will be to draw the hole over towards the center of the circle. After a few turns of the drill the hole should be again examined, and, if necessary, the "drawing-over" process repeated, until the hole is truly central, when the work may be completed; it must be understood that this "drawing-over" should be done before the full diameter of the drill commences to cut, as the grooving plan can have no further effect in drawing over the hole after the full diameter of the drill enters the hole.

It more frequently happens that the relative positions of the parts described are reversed, and the work to be drilled is held in the chuck, and the drill is fed up to it.

In such a case the drill may be gripped in a guide to prevent it turning round, and the drill can be advanced or fed up to the work by means of the dead center; twist-drills are

DRILLING AND BORING IN THE LATHE.

provided with center holes at the shank, and for this especial purpose. When drilling a hole in this manner, it is very necessary to give the drill a true start, and this may be done either by the point of a tool in the slide-rest or by putting in the square center in the tail-stock, and feeding it up against the work, when it will readily cut a true starting center for

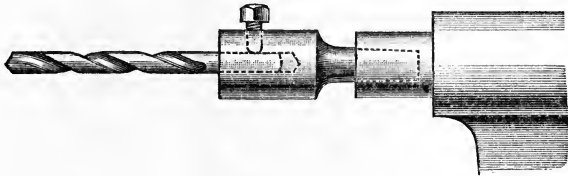

Fig. 310.

the drill; another method of drilling from the back-center is shown in fig. 310, which represents a small drill chuck with a taper shank to fit in the place of the ordinary dead center.

When it is desired to enlarge a "cored" hole by means of a drill, it is essential that the drill be firmly held; this is usually done by fixing it in the tool holder of the slide rest; a cored hole never runs very true, and if the drill is not firmly

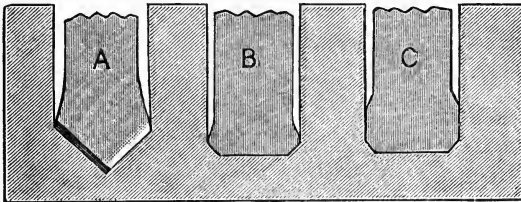

Fig. 311.

Fig. 312.

Fig. 313.

fixed in a central position the point will simply follow the course of the cored hole, and therefore the finished hole will be just as much out of truth. For work of this kind flat drills are usually employed; fig. 311 shows the "pointed" or first drill, used in solid work; fig. 312 is the "rougner," or enlarging drill, and fig. 313 is the "finisher."

DRILLING AND BORING IN THE LATHE.

The *rougher* and *finisher* have a short part past the corner parallel which guides the drill for a straight hole, whereas if the point drill were used to a cored hole it would follow the bend of the core.

The point is ground to an angle varying from 95° to 100° , and when used for wrought iron it is lipped a little, to make it keener.

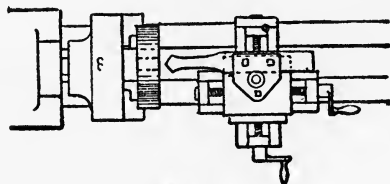

Fig. 314.

These drills work well at 20 ft. per minute, and a traverse of 150 down to 30 revolutions per inch.

The drill, when fixed in the slide-rest, where it must be "packed up" to the exact height of the lathe-centers, can be fed up to the work, either by means of the back center in the case of a saddle slide-rest, or by the feed screw of the rest itself in the simpler form of slide-rest. Fig. 314 shows a view in plan of the latter arrangement.

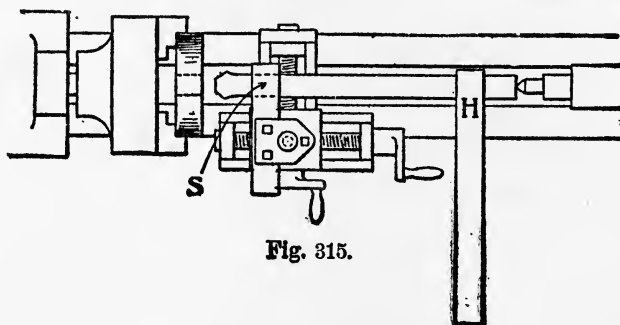

Fig. 315.

Another method of boring out cored holes, or enlarging drilled holes, is shown in fig. 315; here a flat drill, as used in the plan last described, is again employed, but is held in a different manner; instead of being firmly fixed in the slide-

DRILLING AND BORING IN THE LATHE.

rest, it passes through a slotted holder, *S*, which may be made in either of the two forms, *A* or *B*, shown in fig. 316. A center hole is made in the back end of the drill to receive the point of the back center of the lathe, which is used to feed the drill forward while cutting. The drill is kept steady by means of the hooked holder, *H*, the shape of which is shown in figs. 315 and 316, this holder being held in the left hand and pressed downwards while the back center wheel is turned round with the right hand. With drills of this kind a hole can be bored out to any desired diameter at one operation,

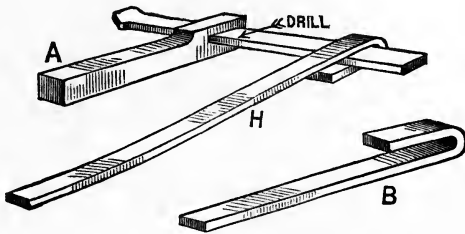

Fig. 316.

provided the drill has been first ground to the right size. It is usual to keep a set of these drills for holes of standard sizes, such as $\frac{1}{2}$ in., $\frac{5}{8}$ in., $\frac{3}{4}$ in., 1 in., $1\frac{1}{4}$ in., $1\frac{1}{2}$ in., and so on, as once the drill is made to the correct size it can always be depended on to produce a hole of exactly corresponding diameter.

In holes of odd sizes, or where an exceptionally good fit is desired, it is better to do the boring with an ordinary slide-rest boring tool, as shown in fig. 237.

When boring holes of small diameter, care must be taken that there is proper clearance at the under part of the cutting

DRILLING AND BORING IN THE LATHE.

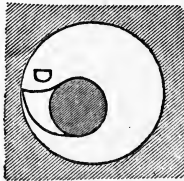

Fig. 317.

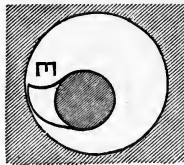

Fig. 318.

tool, as at *D*, fig. 317; otherwise, the tool will rub against the side of the work, as at *E*, fig. 318, and interfere with the proper execution of the work.

The first cut taken through the hole should be a fairly heavy one, so as to clean up the hole perfectly true all round. One or more lighter finishing cuts may be afterwards run through to bring the hole to the exact size required. Care should be taken to set the slide-rest perfectly true, so as to insure a parallel hole being bored. The hole should be carefully tested with a pair of inside calipers after the first cut has been run through, to make certain that this has been done. If the hole is found to taper either way, the slide-rest should be altered accordingly. With a self-acting feed, the hole ought to be perfectly parallel, provided the headstock and lathe bed are set true, the position of the slide-rest not affecting the work at all in this case.

Work which is too awkward in shape, or too heavy to be chucked or bolted to the face plate, may sometimes be bolted down to the saddle of the lathe and bored with a boring bar running between the lathe-centers. Engine and pump cylinders, field magnets for dynamos and motors, and the bearings

DRILLING AND BORING IN THE LATHE.

of engine bed-plates, are examples of work which can be done with advantage in this way. It is, of course, necessary to have a lathe with a saddle and self-acting feed motion, unless a complicated boring bar fitted with its own screw-feeding motion is used.

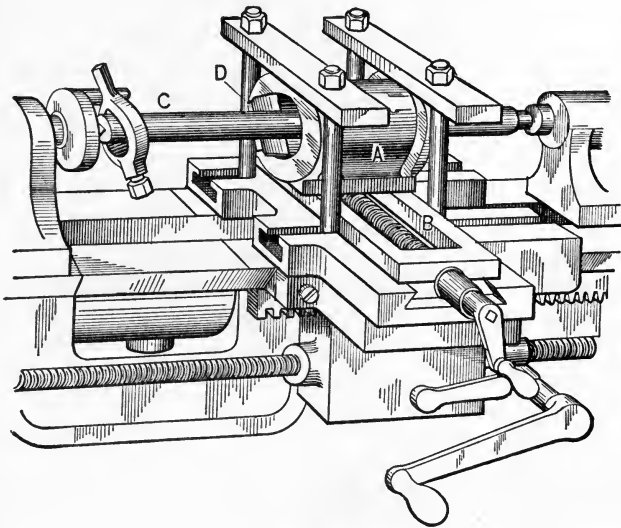

Fig. 319.

An engine cylinder fixed for boring in the above way is shown in the sketch (fig. 319). Here the slide-rest is removed from its usual place, and the cylinder, *A*, is bolted down to the lathe saddle, *B*. A cutter bar, *C*, carrying a cutter, *D*, revolves between the centers in the usual direction, while the cylinder is slowly carried along the lathe bed towards the fast headstock by the self-acting feed motion applied to the saddle.

It is obvious that the cylinder must be bolted down in correct position before the process of boring is commenced, and to facilitate this a circle should first be **marked off with a**

DRILLING AND BORING IN THE LATHE.

pair of compasses round the cored hole in the cylinder, showing the exact size and position of the bore when finished. This should be done at each end of the cylinder, a temporary plug of wood being inserted, on which the center for describing the circle from can be marked. The cylinder is then placed temporarily on the saddle, and the boring bar put between the centers and through the cylinder, as in fig. 320. A pointed scribe, *S*, is wedged on the cutter slot in the bar, so that when the bar revolves the point, *S*, describes a circle of the same diameter as that marked on the cylinder. The cylinder

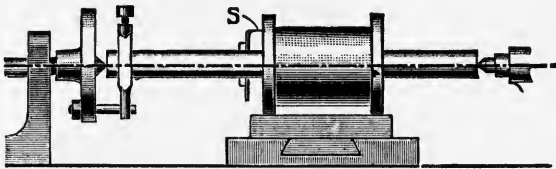

Fig. 320.

is then adjusted in position until the scribe point exactly touches the circle on the cylinder at every point.

For the purpose of trying this the cutter-bar may be revolved by hand. The same test should be applied to each end of the cylinder until it is adjusted to the exact position desired, and the holding-down bolts may then be finally tightened up.

A scribing-block is made of special construction which can be bolted to the boring-bar and rotated with it, while the scribe tests the position of the circle drawn on the cylinder.

A side view of the arrangement of the cutter-bar generally used is shown in fig. 321; this should be made of cast steel, and should be hardened and tempered to a deep straw color.

DRILLING AND BORING IN THE LATHE.

The cutting edges are at *BB*, and proper clearance angles should be given, as shown in the drawing, the cutting edges sloping away in the opposite directions on each side; the extreme diameter, *A*, of the cutter exactly corresponds with the size of the hole it will produce; the cutter is fixed in a slot in the cutter-bar by means of the steel keys, or wedges, *cc*.

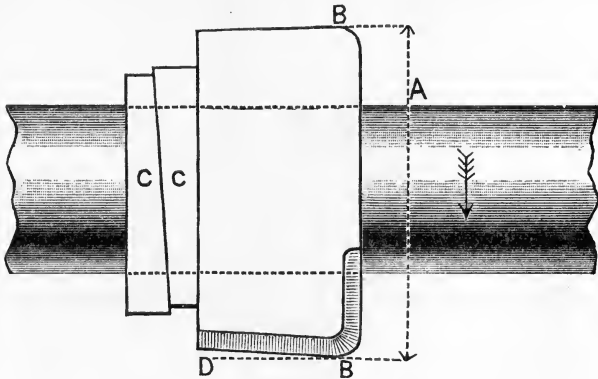

Fig. 321.

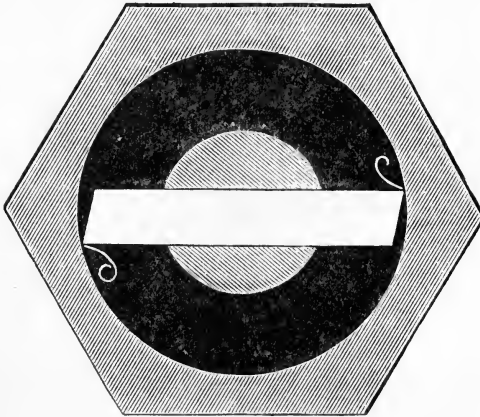

Fig. 322.

Fig. 322 shows an end view of cutter-bar in operation.

A more simple form of cutter is shown in fig. 323; this is made from a piece of round tool steel, fitting into a round hole in the cutter-bar, and it is fastened in place by a small set screw, *S*.

DRILLING AND BORING IN THE LATHE.

As the cutter-bar should be as large as possible, to secure adequate strength, and the cutter should not project more than necessary to provide proper cutting edges and clearance enough to prevent the cuttings clogging round the bar, there is not sufficient room left for a screw head to the set screw. This should therefore be cut off flush with the surface of the cutter-bar, and provided with a saw-slot to receive a screw-driver.

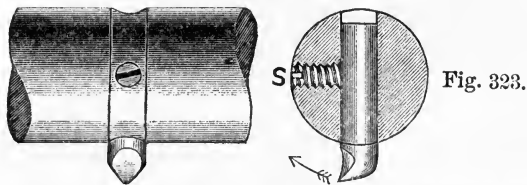
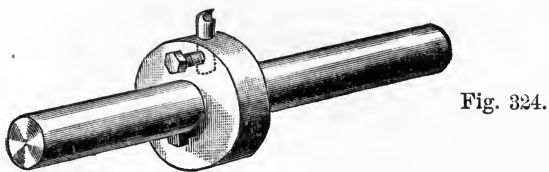

Fig. 324 shows a modification of this plan, which is applicable to cases where the hole to be bored is of large diameter compared to the cutter-bar. Here a cast-iron cutter-block, or collar, is keyed on to the cutter-bar, and the cutter itself is fastened into the collar by means of a small set-screw, as shown.



Cutters of the kind shown in figs. 323 and 324 have an advantage over the kind illustrated in fig. 321, inasmuch as the same cutter can be adjusted to bore holes of different diameters, or the cutter can first be set to take a rough cut through the job, and, after being nicely ground up, a second cut can be taken to finish. The fig. 321 type of cutter is very rigid in its action, and does excellent work; it produces holes of great smoothness and accuracy, but answers better for cast iron and brass than for wrought iron or steel, for which a somewhat keener cutting edge is necessary.

SUMMARY RELATING TO THE LATHE.

Something more than one hundred pages of this volume have been given to the subject of the lathe and its operation; several full-page illustrations have been used which need a few words of explanation, which are added in the following paragraphs to which reference has been already made under the figures.

A triple-gearred, self-acting, screw-cutting and automatic cross-feed lathe is shown in fig. 200, page 216. This is a tool intended principally for turning large diameters and surfaces, yet it is adapted for general boring, turning, screw-cutting, etc., and is provided with compound swivel tool-rest, with clamps for holding tools; in England the tool is described as a triple-gearred, self-acting, sliding, surfacing and screw-cutting lathe.

A special characteristic of this machine is found in the application to the tail-stock or poppet-head of,

1. Gearing, in connection with the rack to slide the tail-stock by hand into position on the shears.
2. A geared adjustment, to operate the dead center in tightening or releasing work.
3. A sliding cross traverse to the upper portion, to permit of fine adjustment of out-of-line-of-centers, for taper turning—all as shown in the figure.

These attachments are only used on the largest lathes; the work operated on being heavy, the surface of shears is fixed close to the ground level.

SUMMARY RELATING TO THE LATHE.

Fig. 214, page 232, shows a triple-gearred, self-acting, screw-cutting and automatic feed lathe, with revolving tool post and cupped washer, for regulating height of cutting tool.

This is a powerful lathe, although not as powerful as shown in fig. 200; the tailstock is actuated by a direct action pinion on hand lever; the shears rest on legs, or stools, raised above the ground level; all as shown in the illustration.

Fig. 240, page 244, represents a double-gearred, self-acting, screw-cutting and automatic feed-lathe.

This is a general lathe for turning, boring and screw-cutting; has self-acting, longitudinal and cross-feeds, actuated by the splined spindle in front, on which is a worm, gearing into a screw wheel on carriage . It is also screw-cutting, being actuated by the long screw or shears in front of the rack; in England the same style of machine is called a self-acting, slide-surfacing and screw-cutting lathe.

The principal distinguishing feature of this tool is the fact that it has two automatic feed motions: 1, for ordinary traverse and cross-feed; 2, an independent feed for screw-cutting, both as shown on the front of the figure.

A double-spindle lathe, or elevated-spindle lathe, is shown in fig. 241, page 245; the arrangement of an elevated spindle in the lathe enables work of a large diameter to be performed in a comparatively small swing lathe; hitherto, when necessity occurred for performing work of a larger diameter than the lathe could swing, it was usual to block or pack under the heads and raise them up from the shears or bed; this necessitated the abandonment of the automatic feed screw, etc.; the substitution of the improvement of the extra elevated spindle enables the screw-cutting or feed motions to

SUMMARY RELATING TO THE LATHE.

be retained; thus a twenty-six-inch ordinary swing lathe, when provided with the improvement, will swing forty-eight inches.

This lathe is suitable for executing work of large diameters and of light weight; it is not suitable for heavy work or heavy cuts.

Fig. 243, page 248, illustrates a boring and surfacing lathe, arranged with duplex, compound hand slide-rests on pedestals or standards which are bolted to base plate.

This description of lathe is generally used for boring and turning pulleys, wheels of large dimensions, etc.

Fig. 274, page 272, shows a view looking down on a lathe.

In operation the workman stands with his face towards the lathe, the head-stock being on his left-hand side and the tail-stock at his right hand.

The left hand actuates the cross feed of the slide rest, the traverse feed being attended to by the right hand; the feed for the screw is thrown in and out of gear with the left hand, and the automatic traverse feed, when used, is generally operated by the left hand, the right hand adjusting the automatic cross feed.

The right hand is also used in adjusting the center of the tail stock, the left hand generally operating the left lever or countershaft.

It may be further explained, that this figure shows a double-gear, self-acting, screw-cutting and automatic feed lathe, as seen in side-view on page 244.

"Work slowly where you must, but work
fast when you can." Shop motto.



TABLES
AND
INDEX

USEFUL TABLES OF WEIGHTS OF IRON AND COMPARISONS OF GAUGES.

Weight of a Superficial Foot of Plate and Sheet Iron

PLATE IRON.		SHEET IRON.			
Thick- ness.	Weight per square foot.	UNITED STATES STANDARD GAUGE. Adopted by Congress, to take effect July 1st, 1893.			
		NUMBER OF GAUGE.	1000's of an inch.	Weight per square foot. OUNCES	Nearest fraction of an inch.
INCHES.	POUNDS.				
$\frac{1}{16}$ in.	$2\frac{1}{2}$	No. 1	.281	180 oz.	$\frac{9}{32}$ in.
$\frac{1}{8}$ "	5	" 2	.265	170 "	$\frac{17}{64}$ "
$\frac{3}{16}$ "	$7\frac{1}{2}$	" 3	.250	160 "	$\frac{1}{4}$ "
$\frac{1}{4}$ "	10	" 4	.234	150 "	$\frac{15}{64}$ "
$\frac{5}{16}$ "	$12\frac{1}{2}$	" 5	.218	140 "	$\frac{7}{32}$ "
$\frac{3}{8}$ "	15	" 6	.203	130 "	$\frac{13}{64}$ "
$\frac{7}{16}$ "	$17\frac{1}{2}$	" 7	.187	120 "	$\frac{3}{16}$ "
$\frac{1}{2}$ "	20	" 8	.171	110 "	$\frac{11}{64}$ "
$\frac{9}{16}$ "	$22\frac{1}{2}$	" 9	.156	100 "	$\frac{5}{32}$ "
$\frac{5}{8}$ "	25	" 10	.140	90 "	$\frac{9}{64}$ "
$\frac{11}{16}$ "	$27\frac{1}{2}$	" 11	.125	80 "	$\frac{1}{8}$ "
$\frac{3}{4}$ "	30	" 12	.109	70 "	$\frac{7}{64}$ "
$\frac{13}{16}$ "	$32\frac{1}{2}$	" 13	.093	60 "	$\frac{3}{32}$ "
$\frac{7}{8}$ "	35	" 14	.078	50 "	$\frac{5}{64}$ "
$\frac{15}{16}$ "	$37\frac{1}{2}$	" 15	.070	45 "	$\frac{9}{128}$ "
1 "	40	" 16	.062	40 "	$\frac{1}{16}$ "
		" 17	.056	36 "	$\frac{9}{160}$ "
		" 18	.050	32 "	$\frac{1}{20}$ "
		" 19	.043	28 "	$\frac{7}{160}$ "
		" 20	.037	24 "	$\frac{3}{80}$ "
		" 21	.034	22 "	$\frac{11}{320}$ "
		" 22	.031	20 "	$\frac{1}{32}$ "
		" 23	.028	18 "	$\frac{9}{320}$ "
		" 24	.025	16 "	$\frac{1}{40}$ "
		" 25	.021	14 "	$\frac{7}{320}$ "
		" 26	.018	12 "	$\frac{3}{160}$ "
		" 27	.017	11 "	$\frac{11}{640}$ "
		" 28	.015	10 "	$\frac{1}{64}$ "
		" 29	.014	9 "	$\frac{9}{640}$ "
		" 30	.012	8 "	$\frac{1}{80}$ "

USEFUL TABLES.

Weight of One Foot of Flat Rolled Iron.

Width.	THICKNESS.								
	$\frac{1}{4}$	$\frac{5}{16}$	$\frac{3}{8}$	$\frac{7}{16}$	$\frac{1}{2}$	$\frac{5}{8}$	$\frac{3}{4}$	$\frac{7}{8}$	1
$\frac{1}{2}$.422	.528	.634	.738	.845				
$\frac{5}{8}$.528	.660	.792	.923	1.056	1.320			
$\frac{3}{4}$.633	.792	.950	1.108	1.265	1.584	1.901		
$\frac{7}{8}$.738	.923	1.108	1.294	1.477	1.840	2.217	2.588	
1	.845	1.056	1.267	1.478	1.690	2.112	2.534	2.956	3.380
$1\frac{1}{8}$.950	1.187	1.425	1.663	1.901	2.375	2.850	3.326	3.802
$1\frac{1}{4}$	1.056	1.320	1.584	1.848	2.112	2.640	3.168	3.696	4.224
$1\frac{3}{8}$	1.161	1.452	1.742	2.032	2.325	2.904	3.484	4.065	4.646
$1\frac{1}{2}$	1.266	1.584	1.900	2.217	2.535	3.168	3.802	4.435	5.069
$1\frac{5}{8}$	1.372	1.716	2.059	2.402	2.746	3.432	4.119	4.805	5.492
$1\frac{3}{4}$	1.497	1.848	2.218	2.589	2.957	3.696	4.435	5.178	5.914
$1\frac{7}{8}$	1.584	1.980	2.376	2.772	3.168	3.960	4.752	5.544	6.336
2	1.689	2.112	2.534	2.957	3.379	4.224	5.069	5.914	6.758
$2\frac{1}{8}$	1.795	2.244	2.693	3.141	3.591	4.488	5.386	6.283	7.181
$2\frac{1}{4}$	1.900	2.376	2.851	3.326	3.802	4.752	5.703	6.653	7.604
$2\frac{3}{8}$	2.006	2.508	3.009	3.511	4.013	5.016	6.019	7.022	8.025
$2\frac{1}{2}$	2.112	2.640	3.168	3.696	4.224	5.280	6.336	7.392	8.448
$2\frac{3}{4}$	2.323	2.904	3.485	4.066	4.647	5.808	6.970	8.132	9.294
3	2.535	3.168	3.802	4.435	5.069	6.337	7.604	8.871	10.138
$3\frac{1}{4}$	2.746	3.432	4.119	4.805	5.492	6.865	8.237	9.610	10.983
$3\frac{1}{2}$	2.957	3.696	4.436	5.175	5.914	7.393	8.871	10.350	11.828
$3\frac{3}{4}$	3.168	3.990	4.752	5.544	6.336	7.921	9.505	11.089	12.673
4	3.380	4.224	5.069	5.914	6.759	8.448	10.138	11.828	13.518
$4\frac{1}{2}$	3.802	4.752	5.703	6.653	7.604	9.504	11.406	13.306	15.208
5	4.224	5.280	6.330	7.392	8.449	10.560	12.673	14.784	16.897
$5\frac{1}{2}$	4.647	5.808	6.970	8.132	9.294	11.616	13.940	16.204	18.587
6	5.070	6.337	7.604	8.871	10.138	12.674	15.208	17.742	20.276

USEFUL TABLES.

Weight of One Foot of Round Iron.

SIZE.	Weight pr. Foot.	SIZE.	Weight pr. Foot.	SIZE.	Weight pr. Foot.
	LBS.		LBS.		LBS.
1/8 in.	.041	1 7/8 in.	5.41	3 1/2 in.	32.07
3/8 ..	.092	1 1/2 ..	5.89	3 5/8 ..	34.40
1/4 ..	.164	1 9/8 ..	6.39	3 3/4 ..	36.82
5/8 ..	.256	1 5/8 ..	6.91	3 7/8 ..	39.31
3/8 ..	.368	1 1/8 ..	7.45	4 ..	41.89
7/8 ..	.501	1 3/4 ..	8.02	4 1/8 ..	44.55
1 1/2 ..	.654	1 3/8 ..	8.60	4 1/4 ..	47.29
1 1/8 ..	.828	1 1/2 ..	9.20	4 3/8 ..	50.11
5/8 ..	1.02	1 1/8 ..	9.83	4 1/2 ..	53.01
1 1/4 ..	1.24	2 ..	10.47	4 5/8 ..	56.00
3/4 ..	1.47	2 1/8 ..	11.82	4 3/4 ..	59.07
1 1/8 ..	1.73	2 1/4 ..	13.25	4 7/8 ..	62.22
1 1/2 ..	2.00	2 3/8 ..	14.77	5 ..	65.45
5/8 ..	2.30	2 1/2 ..	16.36	5 1/8 ..	68.76
1 3/8 ..	2.62	2 5/8 ..	18.04	5 1/4 ..	72.16
1 1/4 ..	2.95	2 3/4 ..	19.80	5 3/8 ..	75.64
1 1/8 ..	3.31	2 7/8 ..	21.64	5 1/2 ..	79.19
1 3/8 ..	3.69	3 ..	23.56	5 5/8 ..	82.83
1 1/4 ..	4.09	3 1/8 ..	25.57	5 3/4 ..	86.56
1 5/8 ..	4.51	3 1/4 ..	27.65	5 7/8 ..	90.36
1 3/8 ..	4.95	3 3/8 ..	29.82	6 ..	94.25

Weight of One Foot of Square Iron.

SIZE.	Weight pr. Foot.	SIZE.	Weight pr. Foot.	SIZE.	Weight pr. Foot.
	LBS.		LBS.		LBS.
1/8 in.	.052	1 7/8 in.	6.89	3 1/2 in.	40.83
3/8 ..	.117	1 1/2 ..	7.50	3 5/8 ..	43.80
1/4 ..	.208	1 9/8 ..	8.14	3 3/4 ..	46.88
5/8 ..	.326	1 5/8 ..	8.80	3 7/8 ..	50.05
3/8 ..	.469	1 1/8 ..	9.49	4 ..	53.33
7/8 ..	.638	1 3/4 ..	10.21	4 1/8 ..	56.72
1 1/2 ..	.833	1 3/8 ..	10.95	4 1/4 ..	60.21
1 1/8 ..	1.06	1 1/2 ..	11.72	4 3/8 ..	63.80
5/8 ..	1.30	1 1/8 ..	12.51	4 1/2 ..	67.50
1 1/4 ..	1.58	2 ..	13.33	4 5/8 ..	71.30
3/4 ..	1.87	2 1/8 ..	15.05	4 3/4 ..	75.21
1 1/8 ..	2.20	2 1/4 ..	16.88	4 7/8 ..	79.22
1 1/2 ..	2.55	2 3/8 ..	18.80	5 ..	83.33
5/8 ..	2.93	2 1/2 ..	20.83	5 1/8 ..	87.55
1 3/8 ..	3.33	2 5/8 ..	22.97	5 1/4 ..	91.88
1 1/4 ..	3.76	2 3/4 ..	25.21	5 3/8 ..	96.30
1 1/8 ..	4.22	2 7/8 ..	27.55	5 1/2 ..	100.80
1 3/8 ..	4.70	3 ..	30.00	5 5/8 ..	105.50
1 1/4 ..	5.21	3 1/8 ..	32.55	5 3/4 ..	110.20
1 5/8 ..	5.74	3 1/4 ..	35.21	5 7/8 ..	115.10
1 3/8 ..	6.30	3 3/8 ..	37.97	6 ..	120.00

USEFUL TABLES.

Weight per Running Foot of Cast Steel.

SIZE.	LBS.	SIZE.	LBS.	SIZE.	LBS.	SIZE.	LBS.
1/4 in. Sq.	.213	1/4 in. Rd.	.167	1 x 1/4	.852	1/2 in. Oct.	.745
1/2855	1/2669	1 1/8 x 3/8	1.43	5/8	1.16
3/4	1.91	3/4	1.50	1 1/4 x 1/2	2.13	3/4	1.67
1	3.40	1	2.67	1 1/2 x 5/8	3.19	7/8	2.28
1 1/4	5.32	1 1/4	4.18	1 3/4 x 3/4	4.46	1	2.98
1 1/2	7.67	1 1/2	6.02	2 x 1/2	3.40	1 1/8	3.77
2	13.63	2	10.71	2 x 5/8	4.25	1 1/4	4.65

Comparison of Principal Gauges in Use.

Num-ber.	UNITED STATES STANDARD.		STUBBS' BIRMINGHAM.		BROWN & SHARP.	
	1000's of an inch.	Pounds per square foot. IRON.	1000's of an inch.	Pounds per square foot. IRON.	1000's of an inch.	Pounds per square foot. IRON.
No. 1	.281	11.25	.300	12.04	.289	11.61
" 2	.265	10.62	.284	11.40	.257	10.34
" 3	.250	10.	.259	10.39	.229	9.21
" 4	.234	9.37	.238	9.55	.204	8.20
" 5	.218	8.75	.220	8.83	.181	7.30
" 6	.203	8.12	.203	8.15	.162	6.50
" 7	.187	7.50	.180	7.22	.144	5.79
" 8	.171	6.87	.165	6.62	.128	5.16
" 9	.156	6.25	.148	5.94	.114	4.59
" 10	.140	5.62	.134	5.38	.102	4.09
" 11	.125	5.00	.120	4.82	.091	3.64
" 12	.109	4.37	.109	4.37	.080	3.24
" 13	.093	3.75	.095	3.81	.072	2.89
" 14	.078	3.12	.083	3.33	.064	2.57
" 15	.070	2.81	.072	2.89	.057	2.29
" 16	.062	2.50	.065	2.61	.050	2.04
" 17	.056	2.25	.058	2.33	.045	1.82
" 18	.050	2.00	.049	1.97	.040	1.62
" 19	.043	1.75	.042	1.69	.036	1.44
" 20	.037	1.50	.035	1.40	.032	1.28
" 21	.034	1.37	.032	1.28	.028	1.14
" 22	.031	1.25	.028	1.12	.025	1.02
" 23	.028	1.12	.025	1.00	.022	.90
" 24	.025	1.00	.022	.88	.020	.80
" 25	.021	.87	.020	.80	.018	.72
" 26	.018	.75	.018	.72	.016	.64
" 27	.017	.68	.016	.64	.014	.57
" 28	.015	.62	.014	.56	.012	.50
" 29	.014	.56	.013	.52	.011	.45
" 30	.012	.50	.012	.48	.010	.40

DECIMAL EQUIVALENTS OF AN INCH.

$\frac{1}{64}$ -----	.015625	$\frac{33}{64}$ -----	.515625
$\frac{1}{32}$ -----	.03125	$\frac{17}{32}$ -----	.53125
$\frac{3}{64}$ -----	.046875	$\frac{35}{64}$ -----	.546875
$\frac{1}{16}$ -----	.0625	$\frac{9}{16}$ -----	.5625
$\frac{5}{64}$ -----	.078125	$\frac{37}{64}$ -----	.578125
$\frac{3}{32}$ -----	.09375	$\frac{19}{32}$ -----	.59375
$\frac{7}{64}$ -----	.109375	$\frac{39}{64}$ -----	.609375
$\frac{1}{8}$ -----	.125	$\frac{5}{8}$ -----	.625
$\frac{9}{64}$ -----	.140625	$\frac{41}{64}$ -----	.640625
$\frac{5}{32}$ -----	.15625	$\frac{21}{32}$ -----	.65625
$\frac{11}{64}$ -----	.171875	$\frac{43}{64}$ -----	.671875
$\frac{3}{16}$ -----	.1875	$\frac{11}{8}$ -----	.6875
$\frac{13}{64}$ -----	.203125	$\frac{45}{64}$ -----	.703125
$\frac{7}{32}$ -----	.21875	$\frac{23}{32}$ -----	.71875
$\frac{15}{64}$ -----	.234375	$\frac{47}{64}$ -----	.734375
$\frac{1}{4}$ -----	.250	$\frac{3}{4}$ -----	.750
$\frac{17}{64}$ -----	.265625	$\frac{49}{64}$ -----	.765625
$\frac{9}{32}$ -----	.28125	$\frac{25}{32}$ -----	.78125
$\frac{19}{64}$ -----	.296875	$\frac{51}{64}$ -----	.796875
$\frac{5}{16}$ -----	.3125	$\frac{13}{16}$ -----	.8125
$\frac{21}{64}$ -----	.328125	$\frac{53}{64}$ -----	.828125
$\frac{11}{32}$ -----	.34375	$\frac{27}{32}$ -----	.84375
$\frac{23}{64}$ -----	.359375	$\frac{55}{64}$ -----	.859375
$\frac{3}{8}$ -----	.375	$\frac{7}{8}$ -----	.875
$\frac{25}{64}$ -----	.390625	$\frac{57}{64}$ -----	.890625
$\frac{13}{32}$ -----	.40625	$\frac{29}{32}$ -----	.90625
$\frac{27}{64}$ -----	.421875	$\frac{59}{64}$ -----	.921875
$\frac{7}{16}$ -----	.4375	$\frac{15}{16}$ -----	.9375
$\frac{29}{64}$ -----	.453125	$\frac{61}{64}$ -----	.953125
$\frac{15}{32}$ -----	.46875	$\frac{31}{32}$ -----	.96875
$\frac{31}{64}$ -----	.484375	$\frac{63}{64}$ -----	.984375
$\frac{1}{2}$ -----	.500	1-----	1

TABLE

CONTAINING THE DIAMETERS, CIRCUMFERENCES AND AREAS OF CIRCLES

Diam.	Area.	Circum.	Diam.	Area.	Circum.
0.0			3.0	7.0686	9.4248
.1	.007854	.31416	.1	7.5477	9.7389
.2	.031416	.62832	.2	8.0425	10.0531
.3	.070686	.94248	.3	8.5530	10.3673
.4	.12566	1.2566	.4	9.0792	10.6814
.5	.19735	1.5708	.5	9.6211	10.9956
.6	.28274	1.8850	.6	10.1788	11.3097
.7	.38485	2.1991	.7	10.7521	11.6239
.8	.50266	2.5133	.8	11.3411	11.9381
.9	.63617	2.8274	.9	11.9456	12.2522
1.0	.7854	3.1416	4.0	12.5664	12.5664
.1	.9503	3.4558	.1	13.2025	12.8805
.2	1.1310	3.7699	.2	13.8544	13.1947
.3	1.3273	4.0841	.3	14.5220	13.5088
.4	1.5394	4.3982	.4	15.2053	13.8230
.5	1.7671	4.7124	.5	15.9043	14.1372
.6	2.0106	5.0265	.6	16.6190	14.4513
.7	2.2698	5.3407	.7	17.3494	14.7655
.8	2.5447	5.6549	.8	18.0956	15.0796
.9	2.8353	5.9690	.9	18.8574	15.3938
2.0	3.1416	6.2832	5.0	19.6350	15.7080
.1	3.4636	6.5973	.1	20.4282	16.0221
.2	3.8013	6.9115	.2	21.2372	16.3363
.3	4.1548	7.2257	.3	22.0618	16.6504
.4	4.5239	7.5398	.4	22.9022	16.9646
.5	4.9087	7.8540	.5	23.7583	17.2788
.6	5.3093	8.1681	.6	24.6301	17.5929
.7	5.7256	8.4823	.7	25.5176	17.9071
.8	6.1575	8.7965	.8	26.4208	18.2212
.9	6.6052	9.1106	.9	27.3397	18.5354

TABLE—(Continued.)**CONTAINING THE DIAMETERS, CIRCUMFERENCES AND AREAS OF CIRCLES**

Diam.	Area.	Circum.	Diam.	Area.	Circum.
6.0	28.2743	18.8496	10.0	78.5398	31.4159
.1	29.2247	19.1637	.1	80.1185	31.7301
.2	30.1907	19.4779	.2	81.7128	32.0442
.3	31.1725	19.7920	.3	83.3229	32.3584
.4	32.1699	20.1062	.4	84.9487	32.6726
.5	33.1831	20.4204	.5	86.5901	32.9867
.6	34.2119	20.7345	.6	88.2473	33.3009
.7	35.2565	21.0487	.7	89.9202	33.6150
.8	36.3168	21.3628	.8	91.6088	33.9292
.9	37.3928	21.6770	.9	93.3132	34.2434
7.0	38.4845	21.9911	11.0	95.0332	34.5575
.1	39.5919	22.3053	.1	96.7689	34.8717
.2	40.7150	22.6195	.2	98.5203	35.1858
.3	41.8539	22.9336	.3	100.2875	35.5000
.4	43.0084	23.2478	.4	102.0703	35.8142
.5	44.1786	23.5619	.5	103.8689	36.1283
.6	45.3646	23.8761	.6	105.6832	36.4425
.7	46.5663	24.1903	.7	107.5132	36.7566
.8	47.7836	24.5044	.8	109.3588	37.0708
.9	49.0167	24.8186	.9	111.2202	37.3850
8.0	50.2655	25.1327	12.0	113.0973	37.6991
.1	51.5300	25.4469	.1	114.9901	38.0133
.2	52.8102	25.7611	.2	116.8987	38.3274
.3	54.1061	26.0752	.3	118.8229	38.6416
.4	55.4177	26.3894	.4	120.7628	38.9557
.5	56.7450	26.7035	.5	122.7185	39.2699
.6	58.0880	27.0177	.6	124.6898	39.5841
.7	59.4468	27.3319	.7	126.6769	39.8982
.8	60.8212	27.6460	.8	128.6796	40.2124
.9	62.2114	27.9602	.9	130.6981	40.5265
9.0	63.6173	28.2743	13.0	132.7323	40.8407
.1	65.0388	28.5885	.1	134.7822	41.1549
.2	66.4761	28.9027	.2	136.8478	41.4690
.3	67.9291	29.2168	.3	138.9291	41.7832
.4	69.3978	29.5310	.4	141.0261	42.0973
.5	70.8822	29.8451	.5	143.1388	42.4115
.6	72.3823	30.1593	.6	145.2672	42.7257
.7	73.8981	30.4734	.7	147.4114	43.0398
.8	75.4296	30.7876	.8	149.5712	43.3540
.9	76.9769	31.1018	.9	151.7468	43.6681

TABLE—(Continued.)

CONTAINING THE DIAMETERS, CIRCUMFERENCES AND AREAS OF CIRCLES.

Diam.	Area.	Circum.	Diam.	Area.	Circum.
14.0	153.9380	43.9823	18.0	254.4690	56.5486
.1	156.1450	44.2965	.1	257.3043	56.8628
.2	158.3677	44.6106	.2	260.1553	57.1770
.3	160.6061	44.9248	.3	263.0220	57.4911
.4	162.8602	45.2389	.4	265.9044	57.8053
.5	165.1300	45.5531	.5	268.8025	58.1195
.6	167.4155	45.8673	.6	271.7164	58.4336
.7	169.7167	46.1814	.7	274.6459	58.7478
.8	172.0336	46.4956	.8	277.5911	59.0619
.9	174.3662	46.8097	.9	280.5521	59.3761
15.0	176.7146	47.1239	19.0	283.5287	59.6903
.1	179.0786	47.4380	.1	286.5211	60.0044
.2	181.4584	47.7522	.2	289.5292	60.3186
.3	183.8539	48.0664	.3	292.5530	60.6327
.4	186.2650	48.3805	.4	295.5925	60.9469
.5	188.6919	48.6947	.5	298.6477	61.2611
.6	191.1345	49.0088	.6	301.7186	61.5752
.7	193.5928	49.3230	.7	304.8052	61.8894
.8	196.0668	49.6372	.8	307.9075	62.2035
.9	198.5565	49.9513	.9	311.0255	62.5177
16.0	201.0619	50.2655	20.0	314.1593	62.8319
.1	203.5831	50.5796	.1	317.3087	63.1460
.2	206.1199	50.8938	.2	320.4739	63.4602
.3	208.6724	51.2080	.3	323.6547	63.7743
.4	211.2407	51.5221	.4	326.8513	64.0885
.5	213.8246	51.8363	.5	330.0636	64.4026
.6	216.4243	52.1504	.6	333.2916	64.7168
.7	219.0397	52.4646	.7	336.5353	65.0310
.8	221.6708	52.7788	.8	339.7947	65.3451
.9	224.3176	53.0929	.9	343.0698	65.6593
17.0	226.9801	53.4071	21.0	346.3606	65.9734
.1	229.6583	53.7212	.1	349.6671	66.2876
.2	232.3522	54.0354	.2	352.9894	66.6018
.3	235.0618	54.3496	.3	356.3273	66.9159
.4	237.7871	54.6637	.4	359.6809	67.2301
.5	240.5282	54.9779	.5	363.0503	67.5442
.6	243.2849	55.2920	.6	366.4354	67.8584
.7	246.0574	55.6062	.7	369.8361	68.1726
.8	248.8456	55.9203	.8	373.2526	68.4867
.9	251.6494	56.2345	.9	376.6848	68.8009

TABLE—(Continued.)**CONTAINING THE DIAMETERS, CIRCUMFERENCES AND AREAS OF CIRCLES.**

Diam.	Area.	Circum.	Diam.	Area.	Circum.
22.0	380.1327	69.1150	26.0	530.9292	81.6814
.1	383.5963	69.4292	.1	535.0211	81.9956
.2	387.0706	69.7434	.2	539.1287	82.3097
.3	390.5707	70.0575	.3	543.2521	82.6239
.4	394.0814	70.3717	.4	547.3911	82.9380
.5	397.6078	70.6858	.5	551.5459	83.2522
.6	401.1500	71.0000	.6	555.7163	83.5664
.7	404.7078	71.3142	.7	559.9025	83.8805
.8	408.2814	71.6283	.8	564.1044	84.1947
.9	411.8707	71.9425	.9	568.3220	84.5088
23.0	415.4756	72.2566	27.0	572.5553	84.8230
.1	419.0993	72.5708	.1	576.8043	85.1372
.2	422.7327	72.8849	.2	581.0690	85.4513
.3	426.3848	73.1991	.3	585.3494	85.7655
.4	430.0526	73.5133	.4	589.6455	86.0796
.5	433.7361	73.8274	.5	593.9574	86.3938
.6	437.4354	74.1416	.6	598.2849	86.7080
.7	441.1503	74.4557	.7	602.6282	87.0221
.8	444.8809	74.7699	.8	606.9871	87.3363
.9	448.6273	75.0841	.9	611.3618	87.6504
24.0	452.3893	75.3982	28.0	615.7522	87.9646
.1	456.1671	75.7124	.1	620.1582	88.2788
.2	459.9606	76.0265	.2	624.5800	88.5929
.3	463.7698	76.3407	.3	629.0175	88.9071
.4	467.5947	76.6549	.4	633.4707	89.2212
.5	471.4352	76.9690	.5	637.9397	89.5354
.6	475.2916	77.2832	.6	642.4243	89.8495
.7	479.1636	77.5973	.7	646.9246	90.1637
.8	483.0513	77.9115	.8	651.4407	90.4779
.9	486.9547	78.2257	.9	655.9724	90.7920
25.0	490.8739	78.5398	29.0	660.5199	91.1063
.1	494.8087	78.8540	.1	665.0830	91.4203
.2	498.7592	79.1681	.2	669.6619	91.7345
.3	502.7255	79.4823	.3	674.2565	92.0487
.4	506.7075	79.7965	.4	678.8668	92.3628
.5	510.7052	80.1106	.5	683.4928	92.6770
.6	514.7185	80.4248	.6	688.1345	92.9911
.7	518.7476	80.7389	.7	692.7919	93.3053
.8	522.7924	81.0531	.8	697.4650	93.6195
.9	526.8529	81.3672	.9	702.1538	93.9336

TABLE—(Continued.)

CONTAINING THE DIAMETERS, CIRCUMFERENCES AND AREAS OF CIRCLES.

Diam.	Area.	Circum.	Diam.	Area.	Circum.
30.0	706.8583	94.2478	34.0	907.9203	106.8142
.1	711.5786	94.5619	.1	913.2688	107.1283
.2	716.3145	94.8761	.2	918.6331	107.4425
.3	721.0662	95.1903	.3	924.0131	107.7566
.4	725.8336	95.5044	.4	929.4088	108.0708
.5	730.6167	95.8186	.5	934.8202	108.3849
.6	735.4154	96.1327	.6	940.2473	108.6991
.7	740.2299	96.4469	.7	945.6901	109.0133
.8	745.0601	96.7611	.8	951.1486	109.3274
.9	749.9060	97.0752	.9	956.6228	109.6416
31.0	754.7676	97.3894	35.0	962.1128	109.9557
.1	759.6450	97.7035	.1	967.6184	110.2699
.2	761.5380	98.0177	.2	973.1397	110.5841
.3	769.4467	98.3319	.3	978.6768	110.8982
.4	774.3712	98.6460	.4	984.2296	111.2124
.5	779.3113	98.9602	.5	989.7980	111.5265
.6	784.2672	99.2743	.6	995.3822	111.8407
.7	789.2388	99.5885	.7	1000.9821	112.1549
.8	794.2260	99.9026	.8	1006.5977	112.4690
.9	799.2290	100.2168	.9	1012.2290	112.7832
32.0	804.2477	100.5310	36.0	1017.8760	113.0973
.1	809.2921	100.8451	.1	1023.5387	113.4115
.2	814.3322	101.1593	.2	1029.2172	113.7257
.3	819.3980	101.4734	.3	1034.9113	114.0398
.4	824.4796	101.7876	.4	1040.6212	114.3540
.5	829.5768	102.1018	.5	1046.3467	114.6681
.6	834.6898	102.4159	.6	1052.0880	114.9823
.7	839.8185	102.7301	.7	1057.8449	115.2965
.8	844.9628	103.0442	.8	1063.6176	115.6106
.9	850.1229	103.3584	.9	1069.4060	115.9248
33.0	855.2986	103.6726	37.0	1075.2101	116.2389
.1	860.4902	103.9867	.1	1081.0299	116.5531
.2	865.6973	104.3009	.2	1086.8654	116.8672
.3	870.9202	104.6150	.3	1092.7166	117.1814
.4	876.1588	104.9292	.4	1098.5835	117.4956
.5	881.4131	105.2434	.5	1104.4662	117.8097
.6	886.6831	105.5575	.6	1110.3645	118.1239
.7	891.9688	105.8717	.7	1116.2786	118.4380
.8	897.2703	106.1858	.8	1122.2083	118.7522
.9	902.5874	106.5000	.9	1128.1538	119.0664

TABLE—(Continued.)**CONTAINING THE DIAMETERS, CIRCUMFERENCES AND AREAS OF CIRCLES.**

Diam.	Area.	Circum.	Diam.	Area.	Circum.
38.0	1134.1149	119.3805	42.0	1385.4424	131.9469
.1	1140.0918	119.6947	.1	1392.0476	132.2611
.2	1146.0844	120.0088	.2	1398.6685	132.5752
.3	1152.0927	120.3230	.3	1405.3051	132.8894
.4	1158.1167	120.6372	.4	1411.9574	133.2035
.5	1164.1564	120.9513	.5	1418.6254	133.5177
.6	1170.2118	121.2655	.6	1425.3092	133.8318
.7	1176.2830	121.5796	.7	1432.0086	134.1460
.8	1182.3698	121.8938	.8	1438.7238	134.4602
.9	1188.4724	122.2080	.9	1445.4546	134.7745
39.0	1194.5906	122.5221	43.0	1452.2012	135.0885
.1	1200.7246	122.8363	.1	1458.9635	135.4026
.2	1206.8742	123.1504	.2	1465.7415	135.7168
.3	1213.0396	123.4646	.3	1472.5352	136.0310
.4	1219.2207	123.7788	.4	1479.3446	136.3451
.5	1225.4175	124.0929	.5	1486.1697	136.6593
.6	1231.6300	124.4071	.6	1493.0105	136.9734
.7	1237.8582	124.7212	.7	1499.8670	137.2876
.8	1244.1021	125.0354	.8	1506.7393	137.6018
.9	1250.3617	125.3495	.9	1513.6272	137.9159
40.0	1256.6371	125.6637	44.0	1520.5308	138.2301
.1	1262.9281	125.9779	.1	1527.4502	138.5442
.2	1269.2348	126.2920	.2	1534.3853	138.8584
.3	1275.5573	126.6063	.3	1541.3360	139.1726
.4	1281.8953	126.9203	.4	1548.3025	139.4867
.5	1288.2493	127.2345	.5	1555.2847	139.8009
.6	1294.3189	127.5487	.6	1562.2826	140.1153
.7	1301.0042	127.8628	.7	1569.2963	140.4292
.8	1307.4052	128.1770	.8	1576.3255	140.7434
.9	1313.8219	128.4911	.9	1583.3706	141.0575
41.0	1320.2543	128.8053	45.0	1590.4313	141.3717
.1	1326.7024	129.1195	.1	1597.5077	141.6858
.2	1333.1603	129.4336	.2	1604.5999	142.0000
.3	1339.6458	129.7478	.3	1611.7077	142.3142
.4	1346.1410	130.0619	.4	1618.8313	142.6283
.5	1352.6520	130.3761	.5	1625.9705	142.9425
.6	1359.1786	130.6903	.6	1633.1255	143.2566
.7	1365.7210	131.0044	.7	1640.2962	143.5708
.8	1372.2791	131.3186	.8	1647.4826	143.8849
.9	1378.8529	131.6227	.9	1654.6847	144.1991

TABLE—(Continued.)

CONTAINING THE DIAMETERS, CIRCUMFERENCES AND AREAS OF CIRCLES.

Diam.	Area.	Circum.	Diam.	Area.	Circum.
46.0	1661.9025	144.5133	50.0	1963.4954	157.0796
.1	1669.1360	144.8274	.1	1971.3572	157.3938
.2	1676.3853	145.1416	.2	1979.2348	157.7080
.3	1683.6502	145.4557	.3	1987.1280	158.0221
.4	1690.9308	145.7699	.4	1995.0370	158.3363
.5	1698.2272	146.0841	.5	2002.9617	158.6504
.6	1705.5392	146.3982	.6	2010.9020	158.9646
.7	1712.8670	146.7124	.7	2018.8581	159.2787
.8	1720.2105	147.0265	.8	2026.8299	159.5929
.9	1727.5697	147.3407	.9	2034.8174	159.9071
47.0	1734.9445	147.6550	51.0	2042.8206	160.2212
.1	1742.3351	147.9690	.1	2050.8395	160.5354
.2	1749.7414	148.2832	.2	2058.8742	160.8495
.3	1757.1635	148.5973	.3	2066.9245	161.1637
.4	1764.6012	148.9115	.4	2074.9905	161.4779
.5	1772.0546	149.2257	.5	2083.0723	161.7920
.6	1779.5237	149.5398	.6	2091.1697	162.1062
.7	1787.0086	149.8540	.7	2099.2829	162.4203
.8	1794.5091	150.1681	.8	2107.4118	162.7345
.9	1802.0254	150.4823	.9	2115.5563	163.0487
48.0	1809.5574	150.7964	52.0	2123.7166	163.3628
.1	1817.1050	151.1106	.1	2131.8926	163.6770
.2	1824.6684	151.4248	.2	2140.0843	163.9911
.3	1832.2475	151.7389	.3	2148.2917	164.3053
.4	1839.8423	152.0531	.4	2156.5149	164.6195
.5	1847.4528	152.3672	.5	2164.7537	164.9336
.6	1855.0790	152.6814	.6	2173.0082	165.2479
.7	1862.7210	152.9956	.7	2181.2785	165.5619
.8	1870.3786	153.3097	.8	2189.5644	165.8761
.9	1878.0519	153.6239	.9	2197.8661	166.1903
49.0	1885.7409	153.9380	53.0	2206.1834	166.5044
.1	1893.4457	154.2522	.1	2214.5165	166.8186
.2	1901.1662	154.5664	.2	2222.8653	167.1327
.3	1908.9024	154.8805	.3	2231.2298	167.4469
.4	1916.6543	155.1947	.4	2239.6100	167.7610
.5	1924.4218	155.5088	.5	2248.0059	168.0752
.6	1932.2051	155.8230	.6	2256.4175	168.3894
.7	1940.0042	156.1372	.7	2264.8448	168.7035
.8	1947.8189	156.4513	.8	2273.2879	169.0177
.9	1955.6493	156.7655	.9	2281.7466	169.3318

TABLE—(Continued.)**CONTAINING THE DIAMETERS, CIRCUMFERENCES AND AREAS OF CIRCLES.**

Diam.	Area.	Circum.	Diam.	Area.	Circum.
54.0	2290.2210	169.6460	58.0	2642.0794	182.2124
.1	2298.7112	169.9602	.1	2651.1979	182.5265
.2	2307.2171	170.2743	.2	2660.3321	182.8407
.3	2315.7386	170.5885	.3	2669.4820	183.1549
.4	2324.2759	170.9026	.4	2678.6476	183.4690
.5	2332.8289	171.2168	.5	2687.8289	183.7832
.6	2341.3976	171.5310	.6	2697.0259	184.0973
.7	2349.9820	171.8451	.7	2706.2386	184.4115
.8	2258.5821	172.1593	.8	2715.4670	184.7256
.9	2367.1979	172.4735	.9	2724.7112	185.0398
55.0	2375.8294	172.7876	59.0	2733.9710	185.3540
.1	2384.4767	173.1017	.1	2743.2466	185.6681
.2	2393.1396	173.4159	.2	2752.5378	185.9823
.3	2401.8183	173.7301	.3	2761.8448	186.2964
.4	2410.5126	174.0442	.4	2771.1675	186.6106
.5	2419.2227	174.3584	.5	2780.5058	186.9248
.6	2427.9485	174.6726	.6	2789.8599	187.2389
.7	2436.6899	174.9867	.7	2799.2297	187.5531
.8	2445.4471	175.3009	.8	2808.6152	187.8672
.9	2454.2200	175.6150	.9	2818.0165	188.1814
56.0	2463.0086	175.9292	60.0	2827.4334	188.4956
.1	2471.8130	176.2433	.1	2836.8660	188.8097
.2	2480.6330	176.5575	.2	2846.3144	189.1239
.3	2489.4687	176.8717	.3	2855.7784	189.4380
.4	2498.3201	177.1858	.4	2865.2582	189.7522
.5	2507.1873	177.5000	.5	2874.7536	190.0664
.6	2516.0701	177.8141	.6	2884.2648	190.3805
.7	2524.9687	178.1283	.7	2893.7917	190.6947
.8	2533.8830	178.4425	.8	2903.3343	191.0089
.9	2542.8129	178.7566	.9	2912.8926	191.3230
57.0	2551.7586	179.0708	61.0	2922.4666	191.6372
.1	2560.7200	179.3849	.1	2932.0563	191.9513
.2	2569.6971	179.6991	.2	2941.6617	192.2655
.3	2578.6899	180.0133	.3	2951.2828	192.5796
.4	2587.6985	180.3274	.4	2960.9197	192.8938
.5	2596.7227	180.6416	.5	2970.5722	193.2079
.6	2605.7626	180.9557	.6	2980.2405	193.5221
.7	2614.8183	181.2699	.7	2989.9244	193.8363
.8	2623.8896	181.5841	.8	2999.6241	194.1504
.9	2632.9767	181.8982	.9	3009.3395	194.4646

TABLE—(Continued.)

CONTAINING THE DIAMETERS, CIRCUMFERENCES AND AREAS OF CIRCLES.

Diam.	Area.	Circum.	Diam.	Area.	Circum.
62.0	3019.0705	194.7787	66.0	3421.1944	207.8451
.1	3028.8173	195.0929	.1	3431.5695	207.6593
.2	3038.5798	195.4071	.2	3441.9603	207.9734
.3	3048.3580	195.7212	.3	3452.3669	208.2876
.4	3058.1520	196.0354	.4	3462.7891	208.6017
.5	3067.9616	196.3495	.5	3473.2270	208.9159
.6	3077.7869	196.6637	.6	3483.6807	209.2301
.7	3087.6279	196.9779	.7	3494.1500	209.5442
.8	3097.4847	197.2920	.8	3504.6351	209.8584
.9	3107.3571	197.6062	.9	3515.1359	210.1725
63.0	3117.2453	197.9203	67.0	3525.6524	210.4867
.1	3127.1492	198.2345	.1	3536.1845	210.8009
.2	3137.0688	198.5487	.2	3546.7324	211.1150
.3	3147.0040	198.8628	.3	3557.2960	211.4292
.4	3156.9550	199.1770	.4	3567.8754	211.7433
.5	3166.9217	199.4911	.5	3578.4704	212.0575
.6	3176.9043	199.8053	.6	3589.0811	212.3717
.7	3186.9023	200.1195	.7	3599.7075	212.6858
.8	3196.9161	200.4336	.8	3610.3497	213.0000
.9	3206.9456	200.7478	.9	3621.0075	213.3141
64.0	3216.9909	201.0620	68.0	3631.6811	213.6283
.1	3227.0518	201.3761	.1	3642.3704	213.9425
.2	3227.1285	201.6902	.2	3653.0754	214.2566
.3	3247.2222	202.0044	.3	3663.7960	214.5708
.4	3257.3289	202.3186	.4	3674.5324	214.8849
.5	3267.4527	202.6327	.5	3685.2845	215.1991
.6	3277.5923	202.9469	.6	3696.0523	215.5133
.7	3287.7474	203.2610	.7	3706.8359	215.8274
.8	3297.9183	203.5752	.8	3717.6351	216.1416
.9	3308.1049	203.8894	.9	3728.4500	216.4556
65.0	3318.3072	204.2035	69.0	3739.2807	216.7699
.1	3328.5253	204.5176	.1	3750.1270	217.0841
.2	3338.7590	204.8318	.2	3760.9891	217.3982
.3	3349.0085	205.1460	.3	3771.8668	217.7124
.4	3359.2736	205.4602	.4	3782.7603	218.0265
.5	3369.5545	205.7743	.5	3793.6695	218.3407
.6	3379.8510	206.0885	.6	3804.5944	218.6548
.7	3390.1633	206.4026	.7	3815.5350	218.9690
.8	3400.4913	206.7168	.8	3826.4913	219.2832
.9	3410.8350	207.0310	.9	3837.4633	219.5973

TABLE—(Continued.)

CONTAINING THE DIAMETERS, CIRCUMFERENCES AND AREAS OF CIRCLES

Diam.	Area.	Circum.	Diam.	Area.	Circum.
70.0	3848.4510	219.9115	74.0	4300.8403	232.4779
.1	3859.4544	220.2256	.1	4312.4721	232.7920
.2	3870.4736	220.5398	.2	4324.1195	233.1062
.3	3881.5084	220.8540	.3	4335.7827	233.4203
.4	3892.5590	221.1681	.4	4347.4616	233.7345
.5	3903.6252	221.4823	.5	4359.1562	234.0487
.6	3914.7072	221.7964	.6	4370.8664	234.3628
.7	3925.8049	222.1106	.7	4382.5924	234.6770
.8	3936.9182	222.4248	.8	4394.3341	234.9911
.9	3948.0473	222.7389	.9	4406.0916	235.3053
71.0	3959.1921	223.0531	75.0	4417.8647	235.6194
.1	3970.3526	223.3672	.1	4429.6535	235.9336
.2	3981.5289	223.6814	.2	4441.4580	236.2478
.3	3992.7208	223.9956	.3	4453.2783	236.5619
.4	4003.9284	224.3097	.4	4465.1142	236.8761
.5	4015.1518	224.6239	.5	4476.9659	237.1902
.6	4026.3908	224.9380	.6	4488.8332	237.5044
.7	4037.6456	225.2522	.7	4500.7163	237.8186
.8	4048.9160	225.5664	.8	4512.6151	238.1327
.9	4060.2022	225.8805	.9	4524.5296	238.4469
72.0	4071.5041	226.1947	76.0	4536.4598	238.7610
.1	4082.8217	226.5088	.1	4548.4057	239.0752
.2	4094.1550	226.8230	.2	4560.3673	239.3894
.3	4105.5040	227.1371	.3	4572.3446	239.7035
.4	4116.8687	227.4513	.4	4584.3377	240.0177
.5	4128.2491	227.7655	.5	4596.3464	240.3318
.6	4139.6452	228.0796	.6	4608.3708	240.6460
.7	4151.0571	228.3938	.7	4620.4110	240.9602
.8	4162.4846	228.7079	.8	4632.4669	241.2743
.9	4173.9279	229.0221	.9	4644.5384	241.5885
73.0	4185.3868	229.3363	77.0	4656.6257	241.9026
.1	4196.8615	229.6504	.1	4668.7287	242.2168
.2	4208.3519	229.9646	.2	4680.8474	242.5310
.3	4219.8579	230.2787	.3	4692.9818	242.8451
.4	4231.3797	230.5929	.4	4705.1319	243.1592
.5	4242.9172	230.9071	.5	4717.2977	243.4734
.6	4254.4704	231.2212	.6	4729.4792	243.7876
.7	4266.0394	231.5354	.7	4741.6765	244.1017
.8	4277.6240	231.8395	.8	4753.8894	244.4159
.9	4289.2243	232.1637	.9	4766.1181	244.7301

TABLE—(Continued.)

CONTAINING THE DIAMETERS, CIRCUMFERENCES AND AREAS OF CIRCLES.

Diam.	Area.	Circum.	Diam.	Area.	Circum.
78.0	4778.3624	245.0442	82.0	5281.0173	257.6106
.1	4790.6225	245.3584	.1	5293.9056	257.9247
.2	4802.8983	245.6725	.2	5306.8097	258.2389
.3	4815.1897	245.9867	.3	5319.7295	258.5531
.4	4827.4969	246.3009	.4	5332.6650	258.8672
.5	4839.8189	246.6150	.5	5345.6162	259.1814
.6	4852.1584	246.9292	.6	5358.5832	259.4956
.7	4864.5128	247.2433	.7	5371.5658	259.8097
.8	4876.8828	247.5575	.8	5384.5641	260.1239
.9	4889.2685	247.8717	.9	5397.5782	260.4380
79.0	4901.6699	248.1858	83.0	5410.6079	260.7522
.1	4914.0871	248.5000	.1	5423.6534	261.0663
.2	4926.5199	248.8141	.2	5436.7146	261.3805
.3	4938.9685	249.1283	.3	5449.7915	261.6947
.4	4951.4328	249.4425	.4	5462.8840	262.0088
.5	4963.9127	249.7566	.5	5475.9923	262.3230
.6	4976.4084	250.0708	.6	5489.1163	262.6371
.7	4988.9198	250.3850	.7	5502.2561	262.9513
.8	5001.4469	250.6991	.8	5515.4115	263.2655
.9	5013.9897	251.0133	.9	5528.5826	263.5796
80.0	5026.5482	251.3274	84.0	5541.7694	263.8938
.1	5039.1225	251.6416	.1	5554.9720	264.2079
.2	5051.7124	251.9557	.2	5568.1902	264.5221
.3	5064.3180	252.2699	.3	5581.4242	264.8363
.4	5076.9394	252.5840	.4	5594.6739	265.1514
.5	5089.5764	252.8982	.5	5607.9392	265.4646
.6	5102.2292	253.2124	.6	5621.2203	265.7787
.7	5114.8977	253.5265	.7	5634.5171	266.0929
.8	5127.5819	253.8407	.8	5647.8296	266.4071
.9	5140.2818	254.1548	.9	5661.1578	266.7212
81.0	5152.9973	254.4690	85.0	5674.5017	267.0354
.1	5165.7287	254.7832	.1	5687.8614	267.3495
.2	5178.4757	255.0973	.2	5701.2367	267.6637
.3	5191.2384	255.4115	.3	5714.6277	267.9779
.4	5204.0168	255.7256	.4	5728.0345	268.2920
.5	5216.8110	256.0398	.5	5741.4569	268.6062
.6	5229.6208	256.3540	.6	5754.8951	268.9203
.7	5242.4463	256.6681	.7	5768.3490	269.2345
.8	5255.2876	256.9823	.8	5781.8185	269.5486
.9	5268.1446	257.2966	.9	5795.3038	269.8628

TABLE—(Continued.)**CONTAINING THE DIAMETERS, CIRCUMFERENCES AND AREAS OF CIRCLES.**

Diam.	Area.	Circum.	Diam.	Area.	Circum.
86.0	5808.8048	270.2770	90.0	6361.7251	282.7433
.1	5822.3215	270.4911	.1	6375.8701	283.0575
.2	5835.8539	270.8053	.2	6390.0309	283.3717
.3	5849.4020	271.1194	.3	6404.2073	283.6858
.4	5862.9659	271.4336	.4	6418.3995	284.0000
.5	5876.5454	271.7478	.5	6432.6073	284.3141
.6	5890.1407	272.0619	.6	6446.8309	284.6283
.7	5903.7516	272.3761	.7	6461.0701	284.9425
.8	5917.3783	272.6902	.8	6475.3251	285.2566
.9	5931.0206	273.0044	.9	6489.5958	285.5708
87.0	5944.6787	273.3186	91.0	6503.8822	285.8849
.1	5958.3525	273.6327	.1	6518.1843	286.1991
.2	5972.0420	273.9469	.2	6532.5021	286.5133
.3	5985.7472	274.2610	.3	6546.8356	286.8274
.4	5999.4681	274.5752	.4	6561.1848	287.1416
.5	6013.2047	274.8894	.5	6575.5498	287.4557
.6	6026.9570	275.2035	.6	6589.9304	287.7699
.7	6040.7250	275.5177	.7	6604.3268	288.0840
.8	6054.5088	275.8318	.8	6618.7388	288.3982
.9	3068.3082	276.1460	.9	6633.1666	288.7124
88.0	6082.1234	276.4602	92.0	6647.6101	289.0265
.1	6095.9542	276.7743	.1	6662.0692	289.3407
.2	6109.8008	277.0885	.2	6676.5441	289.6548
.3	6123.6631	277.4026	.3	6691.0347	289.9690
.4	6137.5411	277.7168	.4	6705.5410	290.2832
.5	6151.4348	278.0309	.5	6720.0630	290.5973
.6	6165.3442	278.3451	.6	6734.6008	290.9115
.7	6179.2693	278.6563	.7	6749.1542	291.2256
.8	6193.2101	278.9740	.8	6763.7233	291.5398
.9	6207.1666	279.2876	.9	6778.3082	291.8540
89.0	6221.1389	279.6017	93.0	6792.9087	292.1681
.1	6235.1268	279.9159	.1	6807.5250	292.4823
.2	6249.1304	280.2301	.2	6822.1569	292.7964
.3	6263.1498	280.5442	.3	6836.8046	293.1106
.4	6277.1849	280.8584	.4	6851.4680	293.4248
.5	6291.2356	281.1725	.5	6866.1471	293.7389
.6	6305.3021	281.4867	.6	6880.8419	294.0531
.7	6319.3843	281.8009	.7	6895.5524	294.3672
.8	6333.4822	282.1150	.8	6910.2786	294.6814
.9	6347.5958	282.4292	.9	6925.0205	294.9956

TABLE—(Concluded.)

CONTAINING THE DIAMETERS, CIRCUMFERENCES AND AREAS OF CIRCLES.

Diam.	Area.	Circum.	Diam.	Area.	Circum.
94.0	6939.7782	295.3097	97.0	7389.8113	304.7345
.1	6954.5515	295.6239	.1	7405.0559	305.0486
.2	6969.3106	295.9380	.2	7420.3162	305.3628
.3	6984.1453	296.2522	.3	7435.5922	305.6770
.4	6998.9658	296.5663	.4	7450.8839	305.9911
.5	7013.8019	296.8805	.5	7466.1913	306.3053
.6	7028.6538	297.1947	.6	7481.5144	306.6194
.7	7043.5214	297.5088	.7	7496.8532	306.9336
.8	7058.4047	297.8230	.8	7521.2078	307.2478
.9	7073.3038	298.1371	.9	7527.5780	307.5619
95.0	7088.2184	298.4513	98.0	7542.9640	307.8761
.1	7103.1488	298.7655	.1	7558.3656	308.1902
.2	7118.1950	299.0796	.2	7573.7830	308.5044
.3	7133.0563	299.3938	.3	7589.2161	308.8186
.4	7148.0343	299.7079	.4	7604.6648	309.1327
.5	7163.0276	300.0221	.5	7620.1293	309.4469
.6	7178.0366	300.3363	.6	7635.6095	309.7610
.7	7193.0612	300.6504	.7	7651.1054	310.0752
.8	7208.1016	300.9646	.8	7666.6170	310.3894
.9	7223.1577	301.2787	.9	7682.1444	310.7035
96.0	7238.2295	301.5929	99.0	7697.6893	311.0177
.1	7253.3170	301.9071	.1	7713.2461	311.3318
.2	7268.4202	302.2212	.2	7728.8206	311.6460
.3	7283.5391	302.5354	.3	7744.4107	311.9602
.4	7298.6737	302.8495	.4	7760.0166	312.2743
.5	7313.8240	303.1637	.5	7775.6382	312.5885
.6	7328.9901	303.4779	.6	7791.2754	312.9026
.7	7344.1718	303.7920	.7	7806.9284	313.2168
.8	7359.3693	304.1062	.8	7822.5971	313.5309
.9	7374.5824	304.4203	.9	7838.2815	313.8451
			100.0	7853.9816	314.1593



TABLE**OF SQUARES, CUBES, SQUARE AND CUBE ROOTS OF NUMBERS.**

Number.	Square.	Cube.	Square Root.	Cube Root.
1	1	1	1.0	1.0
2	4	8	1.414213	1.25992
3	9	27	1.732050	1.44225
4	16	64	2.0	1.58740
5	25	125	2.236068	1.70997
6	36	216	2.449489	1.81712
7	49	343	2.645751	1.91293
8	64	512	2.828427	2.0
9	81	729	3.0	2.08008
10	100	1000	3.162277	2.15443
11	121	1331	3.316624	2.22398
12	144	1728	3.464101	2.28942
13	169	2197	3.605551	2.35133
14	196	2744	3.741657	2.41014
15	225	3375	3.872983	2.46621
16	256	4096	4.0	2.51984
17	289	4913	4.123105	2.57128
18	324	5832	4.242640	2.62074
19	361	6859	4.358898	2.66840
20	400	8000	4.472136	2.71441
21	441	9261	4.582575	2.75892
22	484	10648	4.690415	2.80203
23	529	12167	4.795831	2.84386
24	576	13824	4.898979	2.88449
25	625	15625	5.0	2.92401
26	676	17576	5.099019	2.96249
27	729	19683	5.196152	3.0
28	784	21952	5.291502	3.03658
29	841	24389	5.385164	3.07231
30	900	27000	5.477225	3.10723
31	961	29791	5.567764	3.14138
32	1024	32768	5.656854	3.17480
33	1089	35937	5.744562	3.20753
34	1156	39304	5.830951	3.23961
35	1225	42875	5.916079	3.27106
36	1296	46656	6.0	3.30192
37	1369	50653	6.082762	3.33222
38	1444	54872	6.164414	3.36197
39	1521	59319	6.244998	3.39121
40	1600	64000	6.324555	3.41995

TABLE—(Continued)

OF SQUARES, CUBES, SQUARE AND CUBE ROOTS OF NUMBERS.

Number.	Square.	Cube.	Square Root.	Cube Root.
41	1681	68921	6.403124	3.44821
42	1764	74088	6.480740	3.47602
43	1849	79507	6.557438	3.50339
44	1936	85184	6.633249	3.53034
45	2025	91125	6.708203	3.55689
46	2116	97336	6.782330	3.58304
47	2209	103823	6.855654	3.60882
48	2304	110592	6.928303	3.63424
49	2401	117649	7.0	3.65930
50	2500	125000	7.071067	3.68403
51	2601	132651	7.141428	3.70843
52	2704	140608	7.211102	3.73251
53	2809	148877	7.280109	3.75628
54	2916	157464	7.348469	3.77976
55	3025	166375	7.416198	3.80295
56	3136	175616	7.483314	3.82586
57	3249	185193	7.549834	3.84850
58	3364	195112	7.615773	3.87087
59	3481	205379	7.681145	3.89299
60	3600	216000	7.745966	3.91486
61	3721	226981	7.810249	3.93649
62	3844	238328	7.874007	3.95789
63	3969	250047	7.937253	3.97905
64	4096	262144	8.0	4.0
65	4225	274625	8.062257	4.02073
66	4356	287496	8.124038	4.04124
67	4489	300763	8.185352	4.06154
68	4624	314432	8.246211	4.08165
69	4761	328509	8.306623	4.10156
70	4900	343000	8.366600	4.12128
71	5041	357911	8.426149	4.14081
72	5184	373248	8.485281	4.16016
73	5329	389017	8.544003	4.17933
74	5476	405224	8.603325	4.19833
75	5625	421875	8.660254	4.21716
76	5776	438976	8.717797	4.23582
77	5929	456533	8.774964	4.25432
78	6084	474552	8.831760	4.27265
79	6241	493039	8.888194	4.29084
80	6400	512000	8.944271	4.30887

TABLE—(Continued)**OF SQUARES, CUBES, SQUARE AND CUBE ROOTS OF NUMBERS.**

Number.	Square.	Cube.	Square Root.	Cube Root.
81	6561	531441	9.0	4.32674
82	6724	551368	9.055385	4.34448
83	6889	571787	9.110438	4.36207
84	7056	592704	9.165151	4.37951
85	7225	614125	9.219544	4.39683
86	7396	636056	9.273618	4.41400
87	7569	658503	9.327379	4.43104
88	7744	681472	9.380831	4.44796
89	7921	704969	9.433981	4.46474
90	8100	729000	9.486833	4.48140
91	8281	753571	9.539392	4.49794
92	8464	778688	9.591663	4.51435
93	8649	804357	9.643650	4.53065
94	8836	830584	9.695359	4.54683
95	9025	857375	9.746794	4.56290
96	9216	884736	9.797959	4.57785
97	9409	912673	9.848857	4.59470
98	9604	941192	9.899494	4.61043
99	9801	970299	9.949874	4.62606
100	10000	1000000	10.0	4.64158
101	10201	1030301	10.049875	4.65701
102	10404	1061208	10.099504	4.67233
103	10609	1092727	10.148891	4.68754
104	10816	1124864	10.198039	4.70266
105	11025	1157625	10.246950	4.71769
106	11236	1191016	10.295630	4.73262
107	11449	1225043	10.344080	4.74745
108	11664	1259712	10.392304	4.76220
109	11881	1295029	10.440306	4.77685
110	12100	1331000	10.488088	4.79142
111	12321	1367631	10.535653	4.80589
112	12544	1404928	10.583005	4.82028
113	12769	1442897	10.630145	4.83458
114	12996	1481544	10.677078	4.84880
115	13225	1520875	10.723805	4.86294
116	13456	1560896	10.770329	4.87699
117	13689	1601613	10.816653	4.89097
118	13924	1643032	10.862780	4.90486
119	14161	1685159	10.908712	4.91868
120	14400	1728000	10.954451	4.93242

TABLE—(Continued)**OF SQUARES, CUBES, SQUARE AND CUBE ROOTS OF NUMBERS.**

Number.	Square.	Cube.	Square Root.	Cube Root.
121	14641	1771561	11.0	4.94608
122	14884	1815848	11.045361	4.95967
123	15129	1860867	11.090536	4.97319
124	15376	1906624	11.135528	4.98663
125	15625	1953125	11.180339	5.0
126	15876	2000376	11.224972	5.01329
127	16129	2048383	11.269427	5.02652
128	16384	2097152	11.313708	5.03963
129	16641	2146689	11.357816	5.05277
130	16900	2197000	11.401754	5.06579
131	17161	2248091	11.445523	5.07875
132	17424	2299968	11.489125	5.09164
133	17689	2352637	11.532562	5.10446
134	17956	2406104	11.575836	5.11723
135	18225	2460375	11.618950	5.12992
136	18496	2515456	11.661903	5.14256
137	18769	2571353	11.704699	5.15513
138	19044	2628072	11.747344	5.16764
139	19321	2685619	11.789826	5.18010
140	19600	2744000	11.832159	5.19249
141	19881	2803221	11.874342	5.20482
142	20164	2863288	11.916375	5.21710
143	20449	2924207	11.958260	5.22932
144	20736	2985984	12.0	5.24148
145	21025	3048625	12.041594	5.25358
146	21316	3112136	12.083046	5.26563
147	21609	3176523	12.123455	5.27763
148	21904	3241792	12.165525	5.28957
149	22201	3307949	12.206655	5.30145
150	22500	3375000	12.247448	5.31329
151	22801	3442951	12.288205	5.32507
152	23104	3511808	12.328828	5.33680
153	23409	3581577	12.369316	5.34848
154	23716	3652264	12.409673	5.36010
155	24025	3723875	12.449899	5.37168
156	24336	3796416	12.489996	5.38323
157	24649	3869893	12.529964	5.39469
158	24964	3944312	12.569805	5.40612
159	25281	4019679	12.609520	5.41750
160	25600	4096000	12.649110	5.42883

TABLE—(Continued)**OF SQUARES, CUBES, SQUARE AND CUBE ROOTS OF NUMBERS.**

Number.	Square.	Cube.	Square Root.	Cube Root.
161	25921	4173281	12.688577	5.44012
162	26244	4251528	12.727922	5.45136
163	26569	4330747	12.767145	5.43255
164	26896	4410944	12.806248	5.47370
165	27225	4492125	12.845232	5.48480
166	27556	4574296	12.884098	5.49586
167	27889	4657463	12.922848	5.50687
168	28224	4741632	12.961481	5.51784
169	28561	4826809	13.0	5.52877
170	28900	4913000	13.038404	5.53965
171	29241	5000211	13.076696	5.55049
172	29584	5088448	13.114877	5.56129
173	29929	5177717	13.152946	5.57205
174	30276	5268024	13.190906	5.58277
175	30625	5359375	12.228756	5.59344
176	30976	5451776	13.266499	5.60407
177	31329	5545233	13.304134	5.61467
178	31684	5639752	13.341664	5.62522
179	32041	5735339	13.379088	5.63574
180	32400	5832000	13.416407	5.64621
181	32761	5929741	13.453624	5.65665
182	33124	6028568	13.490737	5.66705
183	33489	6128487	13.527749	5.67741
184	33856	6229504	13.564660	5.68773
185	34225	6331625	13.601470	5.69801
186	34596	6434856	13.638181	5.70826
187	34969	6539203	13.674794	5.71847
188	35344	6644672	13.711309	5.72865
189	35721	6751269	13.747727	5.73879
190	36100	6859000	13.784048	5.74889
191	36481	6967871	13.820275	5.75896
192	36864	7077888	13.856406	5.76899
193	37249	7189057	13.892444	5.77899
194	37636	7301384	13.928388	5.78896
195	38025	7414875	13.964240	5.79889
196	38416	7529536	14.0	5.80878
197	38809	7645373	14.035668	5.81864
198	39204	7762392	14.071247	5.82847
199	39601	7880599	14.106736	5.83827
200	40000	8000000	14.142135	5.84803

CLOSING WORDS.

To progress means primarily a steady and constant forward movement, admitting of pause but not retreat; we speak of slow or rapid progress—thus one may say without limitation, “I am an advocate of progress.”

The aim of this volume is to illustrate the above thought and to advocate a constant advancement; it must be remembered that experience teaches that no enterprise can stand still, and the wise student will make a firm resolve to seek constant development of new powers and greater proficiency both in personal character and in the mechanic arts.

Furthermore, a regular review of first principles, as aimed to be taught in this volume, is not only wise but safe for the reader, as, owing to the varying conditions of trade which necessarily make fluctuations in the “output” of the shop, the article which is the product of the shop cannot remain marketable over long periods without constant improvement in design,—

Again, as to equipment, tools which are modern and best suited to the work to-day, not

only depreciate, but become an actual source of loss in doing their work when compared with the tools of later date, hence, the necessity of a constant progression along new lines founded upon the elementary and unchangeable laws of nature.

Last of all, it may be kindly added, there is a constant going and coming among the personnel of all shops of industry, and in the shifts and changes among men of all grades, is found the opportunity for permanent advance to the well read and capable "coming man."

The author, in closing, wishes a progressive improvement, as indicated by the title of this book, to be the happy outcome of the reader and student.

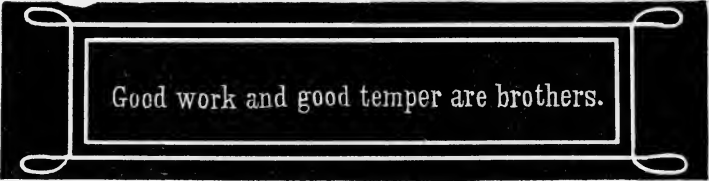

Good work and good temper are brothers.

INDEX

TO THE PROGRESSIVE MACHINIST.

- ACTION OF A MACHINE**, description, 212.
- ADDENDUM CIRCLE**, illustration, 127.
Of a wheel, 124, 127.
- ADJUSTABLE CUTTER BAR**, description and illustration, 301
- ADJUSTABLE SCREW** in a lathe live spindle, 222.
- ADJUSTING CALIPERS** together, illustration, 254.
- ALiquot PARTS**, definition of, 70.
Table of, 70.
- ALLIGATOR WRENCH**, description and illustration, 205.
- ALLOYS**, definition, 44.
Table of, 64.
- ALPHABET, GOTHIC**, for lettering drawings, 97.
- ALUMINIUM**, definition, 24, 44.
- AMALGAM**, definition, 45.
- AMERICAN MACHINIST**, quotation, "How can I harden cast steel," 145.
Quotation, "Work-benches," 152.
- ANGLE**, definition of, 107.
To bisect an, 111.
To draw an, 111.
- ANGLE IRON**, 37.
- ANGLE-PLATE** for chuck, description, 262.
Use of in boring, description and illustration, 291.
- ANNEALING**, description of process, 149.
- ANTI-FRICTION WASHER** in a lathe, description, 222.
- ANTIMONY**, an element, 24.
Description, 45.
Melting point, 64.
Specific gravity of, 57.
- ANVIL**, Blacksmith's, description and illustration, 173.
- APOTHECARIES' WEIGHT**, Table of, 71.
- APRON OF A LATHE CARRIAGE**, description, 224.
Illustration, 225.
- ARC OF A CIRCLE**, to describe with a given radius, 112.
To find the center of, 111.
- AREA**, contraction of, 31.
- AREAS OF CIRCLES**, table of, 313-325.
- ARITHMETICAL FIGURES**, 24.
- ARSENIC**, an element, 24.
- ASBESTOS**, description, 45.
- AUTOMATIC MACHINES**, description, 211.
- AVOIRDUPOIS WEIGHT**, table of, 68.
- BABBITT**, description, 45.
- BACK GEARED HEADSTOCK** of lathe, description and illustration, 302.
- BACK GEARED LATHE**, description, 218.
- BACK GEAR** in a lathe, description, 222.
Wheel in a lathe, description, 222.
- BAND-IRON**, 37.
- BAR-IRON**, 37.
- BARIUM**, an element, 24.
- "BASTARD" CUT FILE**, illustration, 162.
Description, 165.
- BED OF A LATHE**, the, description and illustration, 220.
- BELL CHUCK**, description and illustration, 263.
- BENCHMAN'S TOOLS**, description, 150.
- BENDING STRAIN**, illustration, 34.
- BENT CUTTING TOOL**, description and illustration 238.
- BERYLLIUM**, an element, 24.
- BESSEMER STEEL**, 40, 145.
- BEVEL WHEEL AND PINION**, 129.
Illustration, 130.
- BEVEL MORTISE WHEEL**, illustration, 130.

- BEVEL WHEEL**, description of, 124, 128, 139.
- BISECT**, to, an arc of a circle, 108.
- BISMUTH**, an element, 24.
Description, 45.
Melting point of, 64.
- BLACKBOARD DRAWING**, description, 77.
- BLISTERED STEEL**, 41.
- BORING AND SURFACING LATHE**, description, 305.
Illustration, 248.
- BORING CASTINGS**, how to proceed in, description, 287.
- BORING IN THE LATHE**, description and illustration, 242.
- BORING OPERATION** described, 292.
- BORING TOOL**, description and illustration, 238-243.
- BORING WITH SLIDE REST**, cutting tools, 296.
- BORING WORK** fixed on saddle, description and illustration, 298.
- BORON**, an element, 24.
- BOTTOMING TAP**, illustration, 196.
Description, 198.
- BOW-COMPASSES**, points relating to, 122.
Dividers, illustration and note, 87.
Pen, description, 87.
- BOX-WRENCH**, broaching a, description and illustration, 194.
- BRASS**, description, 46.
Specific gravity of, 57.
- BRASS WORK**, cutting tool for, 237.
- BREAST DRILL**, description and illustration, 192.
- BRITISH ADMIRALTY MEASUREMENTS**, 70.
- BROACHING**, or drifting, description and illustration, 193.
Socket spanner, illustration, 193.
- BROMINE**, an element, 24.
- BRONZE**, description, 46.
Melting point, 64.
Specific gravity of, 57.
- CÆSIUM**, an element, 24.
- CADMIUM**, an element, 24.
- CALCIUM**, an element, 24.
- CALIPER GAUGE**, description and illustration, 256.
- CALIPER RULE**, description, 169.
Illustration, 168.
- CALIPERS**, how to 'set to size,' description, 252.
Inside, description, 171.
Illustration, 170.
Outside, description, 169.
Illustration, 170.
- CAPE CHISEL**, illustration, 160.
Description, 161.
- CARBON**, an element, 24.
- CARBON IN STEEL**, in combination or solution, 146.
- CARE OF THE LATHE**, 289.
- CARET**, weight of a, 66.
- CARRIERS**, or lathe dogs, description and illustration, 274, 275, 276 and 277.
- CASE-HARDENING**, method of, iron, 147.
- CAST-IRON**, description, 37.
Historical note, 37.
Proportion of impurities, 43.
- CAST-IRON WORK**, cutting tool for, description, 237.
- CAST STEEL**, cementation process, 145.
Description, 41.
For cold chisels, 147.
Keen edge on tool for cutting, 301.
Lubricant for cutting, 286.
Rule for tempering, 250.
Turning tools, illustration, 238.
Weight of, 311.
- CENTER GAUGE**, description and illustration, 258.
- CENTERING CRANK SHAFTS** in the lathe, description and illustration, 284.
For the lathe, description, 266.
illustration, 267, 268.
In the lathe, description, 287.
Properly for the lathe, description and illustration, 269.
With a scribing block, description and illustration, 290.
- CENTER LINE** of a drawing, points relating to, 121.

- CENTER LINE** of circles, marking, 122.
- CENTER PUNCH**, illustration, 170.
Description, 171.
Use of, in centering, 267.
- CENTER-SQUARE**, use of, description and illustration, 267.
- CENTRIFUGAL DRILL**, description, 189.
- CERIUM**, an element, 24.
- CHALK AND DRAWING INSTRUMENTS** for blackboard, 77.
- CHEMICAL AFFINITY**, description, 23.
- CHIPPING**, how to use the cold chisel when, illustration and description, 182.
Position of operator when, 182.
- CHISEL**, common flat cold, illustration, 160.
Description, 161.
Cow mouth, illustration and description, 161.
Diamond point, description and illustration, 161.
For chipping metals, description, 161.
How to use the, 181, 184.
Round nose, illustration, 160.
Description, 161.
Sharpening and grinding, description, 184.
- CHISEL-STEEL**, description, 147.
Use of and cutting angle, description and illustration, 182.
- CHLORIN**, an element, 24.
- CHROMIUM**, an element, 24.
- CHUCK AND FACE PLATE WORK**, description and illustration, 288-291.
- CHUCKING STOCK** to make sheaves, description and illustration, 291.
- CHUCKS AND MANDRELS**, description and illustration, 259.
- CIRCLE**, to find the center of *a*, 111.
- CIRCLES**, descriptions, and measurements, 65.
Table of diameters, circumferences and areas, 313-325.
To draw a series of, touching two inclined lines, 113.
- CIRCLE**, to describe *a*, about a square, 115.
To describe *a*, about a triangle, 115.
- CIRCLE**, to describe an octagon about *a*, 117.
To describe *a*, passing through three given points, 112.
To draw a tangent to *a*, from a given point, 112.
To inscribe a hexagon in *a*, 116.
To inscribe *a*, in a square, 115.
To inscribe *a*, in a triangle, 116.
To inscribe an octagon in *a*, 117.
To inscribe a pentagon in *a*, 116.
- CIRCULAR INCH**, definition of, 67.
- CIRCULAR MEASURE**, table of, 65.
- CIRCUMFERENCES OF CIRCLES**, 65.
Table of, 313-325.
- CLASSIFICATION OF MACHINE TOOLS**, 211.
Machine work, description, 214.
- CLEARANCE** in boring, illustration and description, 297.
In lathe cutting tool, description, 234.
In teeth of wheels, 138.
- COBALT**, an element, 24.
- CO-EFFICIENT**, definition, 33.
- COG WHEEL**, description, 126.
- COHESION**, definition, 33.
- COLD CHISEL**, the, illustration and description, 160.
- "COLD-SHORT,"** definition, 32.
- COLOR** in tempering steel, 149.
- COLUMBIUM**, 24.
- COMBUSTION**, power of, 23.
- COMPARISON** of principal gauges, 311.
- COMPASSES AND DIVIDERS**, illustration, 85, 86.
- COMPASSES**, description, 85.
- COMPOUND MACHINES**, description, 23, 211.
Slide rest of a lathe, description and illustration, 226.
- COMPRESSION STRAIN**, illustration, 34.
- CONE** in a lathe, description, 222.
- CONSTRUCTION OF A LATHE**, conditions required in the, 223.
Main point in, 263.
- CONTENTS OF BOOK, IX, X.**
- CONTRACTION OF AREA**, 87.

- COPPER**, an element, 24.
Description, 46.
- COPPER HAMMERS**, description, 156.
- COPPER**, melting point of, 64.
Specific gravity of, 57.
Strength of, 58.
- COPYING DRAWINGS**, tracings, points relating to, 120.
- "CORED" CASTINGS**, description, 292.
Holes, how to true, description, 294.
- CORUNDUM**, description, 46.
- COUNTERBALANCE**, in boring using a face plate, description and illustration, 291.
On driving plate of lathe, 285.
On face plate, description, 263.
- COUNTERSHAFT** for driving lathe, description and illustration, 228.
- COUNTERSINKING** and centering mandrels, description and illustration, 270.
- COVERS** for gearing, 138.
- COW-MOUTH CHISEL**, illustration and description, 161.
- CUBE**, definition of a, 69.
- CUBE ROOT**, table of, 326-330.
- CUBES**, table of, 326-330.
- CUBIC FOOT**, definition of, 69.
- CUBIC INCH**, definition of, 69.
- CUT-GEAR**, description of a, 130-138.
- CUTTER-BAR**, for boring in lathe, description and illustration, 300.
- CUTTING ANGLE OF TOOLS** for different materials, 237.
- CUTTING DRIFT**, description, 194.
- CUTTING-OFF TOOL**, description and illustration, 238.
- CUTTING PIPING**, description, 202.
Shafting and bars, description, 203.
- CUTTING-TOOLS**, best angle, description and illustration, 235.
Forging and grinding, description, 233.
Used in machines, description, 217.
- CRANK SHAFTS**, turning, description and illustration, 283, 284.
- CROSS-HATCHING** in drawing, 102.
- CRUCIBLE STEEL**, description, 41.
- CYLINDER**, how to chuck for boring, description and illustration, 289.
- DEAD CENTER** of a lathe, 223.
- DECIMAL EQUIVALENTS** of an inch, 312.
- DECIMALS**, to read percentage, note, 41.
- DEDICATION** of the work, V.
- DEGREE**, definition, 65.
- DEGREES OF CIRCLES**, table of, 65.
- DELTA**, an alloy, description, 46.
- DEPTH GAUGE**, description and illustration, 257.
- DESIGNING GEAR WHEELS**, 134.
- DIAMETER OF WHEELS**, 126, 127, 130.
- DIAMETERS OF CIRCLES**, table of, 313-325.
- DIAMOND POINT CHISEL**, description and illustration, 161.
Cutting tool, description and illustration, 238.
- DIDYMIUM**, an element, 24.
- DIES**, screw cutting, description and illustration, 200.
- DIMENSIONING DRAWINGS**, description, 99, 100.
- DIVIDERS AND COMPASSES**, illustration, 85.
Description, 85.
Points relating to, 122.
Spring, illustration, 170.
Description, 171.
- DIVIDE**, to, a line into equal parts, 110.
- DOG CHUCK**, description and illustration, 261, 289.
- DOUBLE DRILL**, description, 189.
- DOUBLE-GEARED LATHE**, the, description, 219.
Self-acting, screw-cutting and automatic feed lathe, description, 244, 304.
- DOUBLE SPINDLE LATHE**, illustration, 245.
Description, 304.
- DRAWING AND DESIGNING GEARS**, 134.
A wheel and pinion, illustration, 135.
- DRAWING BOARD**, description, 82.
From a model, note, 77.
- DRAWING** materials and instruments 79.
On a blackboard, 77.

- DRAWING** paper, fixing, to the drawing board, 123.
 Paper, the right side of, 121.
 Pens, description, 91.
 Pins, or thumb tacks, 83.
 Scales, 88.
 To scale, 88.
- DRILL**, best angle for cutting edge of a, 295.
 For ratchet brace, illustrated, 191.
 Grinding and manipulation in lathe, 243.
- DRILLING** and boring in the lathe, 292-301.
 Machines, description, 189.
 Operation, description, 214, 292.
 With a slotted holder, description and illustration, 295.
- DRILLS** for trueing cored holes in the lathe, description and illustration, 294.
 Speed and traverse, 295.
 Use of in the lathe, description, 242.
- DRIVING FIT**, description, 254.
 Work between the centers of the lathe, description and illustration, 271.
- DROSS**, description, 47.
- DRY MEASURE**, table of, 68.
- DUCTILE**, a quality, 32.
- ELASTICITY**, a quality, 32.
- ELASTIC LIMIT**, 31.
- ELECTRICITY**, 23.
- ELEMENTARY SUBSTANCES**, list of, 24.
- ELEMENT**, definition, 29.
- ELEVATING**, or double spindle lathe, illustration, 245.
- ELLIPSE**, to describe an, when the length and breadth are given, 118.
- ELONGATION**, 31.
- EMERY**, description, 47.
 For final polish in lathe, description and illustration, 285.
- END PLATES**, use of, in centering crank shafts, description and illustration, 284.
- ENGINE CYLINDER** fixed for boring, description and illustration, 298.
- ENGINE LATHE**, the, description, 219.
- ENGINE TOOL**, description of, 210.
- ERASER**, points relating to, 122.
- ERBIUM**, an element, 24.
- EXPANDING DRILL**, description, 189.
- FACE PLATE**, description, 260.
 Of a lathe, description, 222.
 Use of, on turning work, 288.
- FACTORY ACT** to protect employees, 138.
- FATIGUED**, a quality, 32.
 Of metals, 62.
- FEED** of lathe, reverse motion for the, 224.
- FIGURES**, arithmetical, 24.
 For dimensioning drawings, 97.
- FILE CARDS**, description and use of, 180.
- FILE**, "cut" of the, illustration, 162.
 Handle, illustration, 166.
 Description, 167.
 Holder for surfacing, illustration, 167.
 Description, 167.
 Resharpening and cleaning a, 180.
- FILES**, general description and use of, 162.
 Illustration and section of different, 163, 164.
 Proper method of using, 177.
- FILING**, the operation of, described, 178.
- FINISHED SURFACES**, "points" relating to, 122.
- "FINISHER" DRILL**, description and illustration, 294.
- FINISHING DRILL**, description, 189.
 Surfaces in the lathe, 285.
- "FIRST CUT"** in turning castings, description, 287.
- FITTING AND ERECTING**, description, 174.
- FLAT BASTARD FILE**, illustration, 166.
 Description, 166.
- FLANGED WHEEL**, description, 129.
- FLAT IRON**, weight of, 309.
- FLUID MEASURE**, table of, 71.
- FLUORIN**, an element, 24.
- FOOT**, square, definition of, 67.
- FOOT LATHE**, the, description, 218.
- "FORCED FIT,"** description, 254.

- FORGING** cutting tools for the lathe, description, 233, 251.
- FREE-HAND DRAWING**, 73-78.
Points relating to, 119.
- FRENCH MONEY**, table of, 72.
- FRENCH WEIGHTS AND MEASURES**, table of, 71.
- FRICTION** gear wheels, 134.
In worm wheels, 131.
- GALLIUM**, an element, 24.
- GALLON**, British Imperial, capacity of, 69.
U. S. standard, capacity of, 69.
- GALVANISM**, 23.
- GAUGE**, description, 257.
Plug and collar, description, 255.
- GAUGES**, comparison of standard sheet iron, 308.
- GEARING**, description of, 124, 126, 127.
Helical teeth, note, 139.
Proportion of teeth, 138.
- GEARS**, train of, description, 139.
- GEOMETRICAL DRAWING**, problems in, 107.
- GEOMETRY**, elementary definitions, 107.
Problems in, 107.
- GERMANIUM**, an element, 24.
- GLASS**, description, 47.
- GLUCINAM**, an element, 24.
- GOLD**, an element, 24.
Description, 47.
Melting point, 64.
Specific gravity of, 57.
- GOSSAMER IRON**, description, 37.
- GRADES** of tool steel, and percentage of carbon contained, 147.
- GRAVITATION**, 23.
- GRAVITY**, 53.
Specific of bodies, 55.
Table of specific, 54.
- GRAY-IRON**, description, 38.
- GRINDING OPERATIONS**, description, 215.
- GRIP OF PIPE-TONGS**, description, 203.
Vise, description, 201.
- GROOVED FRICTION WHEELS**, 134.
- GROOVE-IRON**, 37.
- GUN-METAL**, description, 47.
- HACK-SAW**, description and illustration, 203.
- HAMMER**, how to keep the face true, 158.
"How to mount the handle," 177.
How to use the hand, 158, 175.
Position when using the, 177.
Description, 155.
Illustrations, 156, 157.
"The duration of the blow," 176.
The Machinist's, description, 176.
- HAND BASTARD-FILE**, illustration, 163.
Description, 166.
- HAND DRILLING**, operation, description, 189.
- HAND-LATHE**, description, 218.
- HANDLED NUT**, on tail spindle of lathe, 223.
- HAND TOOLS**, description and illustration, 209.
- HARD STEEL**, description, 145.
- HALF-ROUND BASTARD-FILE**, illustration, 163.
Description, 165.
- HEAD STOCK OF LATHE**, The, description, 220.
Illustration, 221.
- HEIGHT OF CUTTING TOOLS**, description, 236.
- HELICAL TEETH ON GEARING**, note, 139.
Wheel, illustration, 132.
Description, 133.
- HEXAGON**, to construct on a given straight line, 116.
To inscribe a, in a circle, 116.
- HEXAGON-IRON**, 37.
- HOOP-IRON**, 37.
- HOT-SHORT**, definition, 32.
- HOW TO WORK**, 19.
- HYDROGEN**, 24.
Specific gravity of, 55.
- INCLINED PLANE**, The, 23.
Description, 211.
- INDEPENDENT FEED-LATHE**, description, 218.
Jaw chuck, description and illustration, 260.

- INDEX**, arrangement of, 14.
- INDIA INK**, points relating to, 121.
- INDIUM**, an element, 24.
- INKING-IN DRAWINGS**, description, 95.
Points relating to, 119, 120, 123.
- INKING LINES**, illustrations, 92, 93.
- INSIDE CALIPERS**, illustration, 170.
Description, 171.
- INSTRUMENTS**, for blackboard, 77.
For mechanical drawing, 79.
- INTERNAL GEAR WHEEL**, illustration, 132.
- IODINE**, an element, 24.
- IRIDIUM**, an element, 24.
- IRON**, as an elementary body, 24.
Cast, proportion of impurities, 43.
Gray and white, 38.
Melting-point, 64.
Puddle-ball, 42.
Specific gravity of, 57.
Strength of, 58.
- KEMMERLING, GUSTAVE**, dedication to, V.
- KNIFE-EDGE**, side-cutting tool, description, 240.
- KNOT**, definition, 70.
- LANTHANUM**, an element, 24.
- LATHE, BACK-GEARED**, description, 218.
Boring and surfacing, special features, description, 305.
Boring and surfacing, illustration, 248.
Carriage, apron and feed-motion, 225.
Description and illustration, 224.
Compound slide-rest, description and illustration, 226.
- LATHE COUNTER-SHAFT**, description and illustration, 228.
- LATHE-DOG**, illustration, VI.
- LATHE, DOUBLE-GEARED**, self-acting screw-cutting, illustration, 244.
Double-geared, description, 219.
- LATHE, ELEVATED SPINDLE**, special feature description, 304.
Double spindle elevating, illustration, 245.
- LATHE, ELEVATED SPINDLE**, classification of forms of, 218.
Cutting tools used in, description, 217.
End view, showing cutting tool in operation, illustration, 273.
Head-stock of a, illustration, 221.
In operation, turning, illustration, 272.
Operations performed in, 217.
Parts of the, description, 219.
Position of operator, description, 305.
Proportions, illustration and description, 302.
Screw-cutting, The, description, 218.
Self-acting screw-cutting, illustration, 216.
Self-acting slide, description, 218.
Single-gear, The, description, 219.
Special characteristics of, described, 303, 304.
Speed on different materials, description, 286.
Steady rest for, description and illustration, 231.
The foot, description, 218.
The surfacing, description, 218.
Tool-post, description and illustration, 230.
Triple-gear, description, 219.
Triple-geared, self-acting, illustration, 232.
Triple-geared, self-acting, screw-cutting, and automatic cross-feed, description, 303.
- LAWS OF NATURE**, 26.
- LEAD**, an element, 24.
Description of, 48.
Melting-point, 64.
Specific gravity of, 57.
Strength of, 58.
- LETTERING DRAWINGS**, directions for, 96.
Pens, illustration, 98.
- LEVER**, definition of the, 23.
Description and principles of, 211.
- LIMESTONE**, description, 48.
- LINE A**, definition of, 107.
- LIP-DRILL**, description, 189.
- LIQUID**, definition of a, 30.

- LIQUID MEASURE**, table of, 69.
- LITHIUM**, an element, 24.
- LIVE CENTER OF A LATHE**, description, 222.
- LIVE-SPINDLE**, in a lathe, description, 222.
- LONG MEASURE**, table of, 67.
- LUBRICATION**, in cutting tools, illustration, 215.
- LUBRICANT**, used in screw-cutting, description, 201.
- MACHINE**, compound, 23.
Description of a, 210.
The action of a, description, 212.
Tool, description of a, 210.
Work, classification of, description, 214.
- MACHINERY**, definition, 213.
- MACHINES** are a combination of mechanical powers, 213.
Design and proportions of, 213.
Division of, 23.
Strength of the parts of, 213.
- MACHINE-SHOP PRACTICE**, art underlying, 14.
- MACHINIST**, definition, 213.
- MACHINISTS**, two classes of, 17.
- MAGNESIUM**, an element, 24.
- MALLEABLE CASTINGS**, case hardening, 148.
Definition, 32.
Iron, 38.
- MANDREL**, use of lathe, description and illustration, 264, 265.
- MANDRELS AND CENTER-POINTS**, description, 287.
For turning, care of, 264.
- MANGANESE**, an element, 24.
Description, 48.
- MANGANESE-STEEL**, 41.
- MAGNETISM**, 23.
- MATERIALS AND INSTRUMENTS**, drawing, 79.
Important principles relating to strength of, 60.
Preliminary definitions 29.
Strength of, definitions, 31.
Table of, strength of, 58.
- MATTER**, definition, 29.
- MEASURES**, of length, 67.
Of surface, 67.
Weights and, 65.
- MEASURING APPLIANCES**, description, 251.
- MECHANICAL DRAWING**, points relating to, 119.
Powers, description, 211.
- MELTING-POINT OF SOLIDS**, 63.
- MERCURY**, an element, 24.
Description, 48.
Melting-point, 64.
Specific gravity of, 57.
- METAL**, definition and note, 30.
- METALS**, fatigue of, 62.
Tempering and hardening, 143.
- MICROMETER CALIPERS**, description and illustration, 255.
- MILE**, an English, definition of, 70.
- MILL-BASTARD FILE**, illustration, 162.
Description, 165.
- MILLED SCREW**, description, 195.
- MILLING OPERATIONS**, description, 214.
- MINERALS**, definition, 48.
- MITER WHEEL**, illustrations of, 125, 127, 131.
- MODEL**, a drawing from a, note, 77.
- MOLYBDENUM**, an element, 24.
- MONKEY WRENCH**, description, 171, 205.
Illustration, 172.
- MORTISE WHEEL**, spur, illustration, 129.
- MOTION**, three laws of, 55.
- MUNTZ-METAL**, description, 48.
- NATURE**, laws of, 26.
- NAUTICAL MEASURES**, table of, 70.
- NEEDLE-POINTS**, description, 93.
- NEODYMIUM**, an element, 24.
- NICKEL**, an element, 24.
Description, 49.
- NIOBIUM**, an element, 24.
- NITROGEN**, an element, 24.
- OCTAGON**, to convert a square into an, 117.
To describe an, about a circle, 117.

- OCTAGON**, to describe an, on a given straight line, 117.
To describe an, in a circle, 117.
- OIL**, use of, polishing in the lathe, 286.
Use of, turning cast-steel, 286.
- OILING** loose headstock center, 287.
- OSMIUM**, an element, 24.
- OUTSIDE CALIPERS**, description, 169.
Illustration, 170.
- OXYGEN**, an element, 24.
- PACKING PIECES**, use of, in chucking cylinder, description and illustration, 289.
- PALLADIUM**, an element, 24.
- PAPER RULE OR SCALE**, 122.
- PARALLEL LINE**, to draw a, through a given point, 109.
- PARALLELOGRAM**, to construct a, the sides and angle being given, 114.
- PARTING TOOL**, description and illustration, 241.
- PEN**, how to hold, illustrations, 92, 93.
- PENCIL**, a serviceable, kind to use, 76.
How to hold, illustrations, 74, 76.
- PENCILING**, description, 94.
Points relating to, 120, 122, 123.
- PENCIL MARKS**, to make permanent, 121.
- PENS**, drawing, description and illustration, 91.
- PENTAGON**, to inscribe a, in a circle, 116.
- PERPENDICULAR**, to draw a, to a straight line, 108.
To draw a, to a straight line from a given point, 108.
To draw a, to a straight line from any point, 109.
- PEWTER**, specific gravity of, 57.
- PHOSPHOR-BRONZE**, description, 49.
- PHOSPHOR-TIN**, description, 49.
- PHOSPHORUS**, description of, 24.
Melting point of, 63.
Specific gravity of, 57.
- PHOTOGRAPHIC GROUPS** of machinists, 15.
- PIG IRON**, description, 38.
- PINION WHEEL**, 126, 129.
- PIPE CUTTER**, description and illustration, 202.
- PIPE TONGS**, illustration, 202.
Vise, description and illustration, 201.
Wrench, description and illustration, 172.
- PITCH LINE**, illustrations, 127, 128.
Of a wheel, 124, 128.
Proportions of teeth, 138.
- PLANE**, definition of, 122.
- PLANING OPERATIONS**, description, 214.
- PLAN OF A LATHE**, description, 305.
- PLASTER**, description, 50.
- PLATE-IRON**, 37.
Weight of, 308.
- PLATINUM**, 24.
Description, 49.
Specific Gravity of, 55-57.
- PLUG AND COLLAR GAUGE**, illustration, 256.
- PLUG TAP**, illustration, 196.
Description, 198.
- PLUMBAGO**, description, 49.
- POINT**, A, definition, 107.
- "POINTS" relating to drawing, 119.
- POLISHING SURFACE** of pulley in lathe, 285.
Wrought iron, steel, etc., description, 286.
- PORTFOLIO-ENVELOPES**, description, 77.
- POSITION** characteristic of a good workman, 172.
Of cutting tools in lathe, 237.
- POTASSIUM**, an element, 24.
- POUNCE**, use of, points relating to, 120.
- POWER**, water-, wind-, tide-, etc., 23.
- PRACTICE**, drawing on the blackboard, 78.
In free-hand drawing, 75.
- PRASEODYMIUM**, an element, 24.
- PREVENTION OF ACCIDENTS** with gearing, 138.
- PROBLEMS** in geometrical drawing, 107.
- "PROPERTY" of a thing, definition, 30.
- PROPORTIONS** of teeth, note, 126.
Of wheels, 134, 136.
- PROTRACTOR**, description of the, 90.
- PRUSSIAN OF POTASH**, case-hardening with, 147.

- PUDDLE-IRON**, 42.
- PULLEY**, description, 211.
- PUNCH-CENTER**, illustration, 170.
Description, 171.
- PUNCHING AND SHEARING OPERATIONS**, description, 215.
- PURCHASING DRAUGHTING TOOLS**, 79.
- QUALITY**, definition, 30.
- RACK AND PINION**, 129.
- RACK**, illustration of a, 131.
- RAISE AND FALL SLIDE REST**, in lathe, description and illustration, 227.
- RAKE**, cutting angle, etc., in lathe tools, description and illustration, 234.
- RATCHET** Brace, description and illustration, 190.
Drill, description and illustration, 190.
- RAZOR TEMPER**, in hard steel, description, 147.
- READ WORKING DRAWINGS**, To, description, 104.
- RESISTANCE**, definition, 33.
- REVERSE MOTION** for feeds of lathe, 224.
- REVERSING LATHE COUNTERSHAFT**, description and illustration, 229.
- RHODIUM**, an element, 24.
- ROMAN FIGURES**, table of, 66.
- "ROUGHER DRILL,"** description, 189.
Illustration, 294.
- ROUGHING** cut, in a lathe, description, 242.
Tool, description and illustration, 238.
- ROUND IRON**, weight of, 310.
- ROUND-NOSE** Chisel, illustration, 160.
Description, 161.
Cutting tool, description and illustration, 238.
- RUBIDIUM**, an element, 24.
- RULE** for tempering tools, 250.
Two-foot measuring, illustration and description, 58, 163.
- RUTHENIUM**, an element, 24.
- SADDLE** or bridge of a lathe, description, 224.
- SAMARIUM**, an element, 24.
- SAW FILE TEMPER**, description, 147.
- SCALE DRAWING**, how to read, 105, 106.
- SCALE**, flat drawing, illustration, 89.
Paper, points relating to, 122.
Triangular drawing, 88.
- SCANDIUM**, an element, 24.
- SCIENCE**, definition of, 13.
- SCRAPERS**, used in surfacing, illustration and description, 186.
- SCRAP-IRON**, 37.
- SCRATCH GAUGE**, illustration and description, 167.
- SCREW** Eye, description, 195.
Feed, description, 195.
Gauge, description, 195.
Plate, description, 195.
Press, description, 195.
Punch, description, 195.
Tap, description, 197.
The, 23, 197, 211.
The, a spiral inclined plane, description, 195.
Thread, description, 195.
Wrench, description, 197.
- SCREW-BLANK**, description, 195.
- SCREW CUTTING**, description, 195, 197.
Illustration, 197.
- SCREW-CUTTING LATHE**, description, 197, 218.
- SCRIBERS**, or markers, description and illustration, 159.
How to use, description, 188.
- SCRIBING-BLOCK**, use in boring work, 299.
- SCRIBING-CENTERS**, of crank shafts, description and illustration, 28^c 284.
- SCROLL-IRON**, 37.
- SECTION LINES**, "points" relating to, 120.
Drawings, illustration, 102.
- SECTION-LINING**, hub of wheel, illustration, 103.
- SELF-ACTING SLIDE LATHE**, description, 218.
- SELF-CENTERING CHUCK**, description and illustration, 259, 288.

- SET-SQUARE**, illustration, 84.
- SETTING-UP SCREW**, description, 195.
- SHADE LINES**, in drawings, points relating to, 120.
- SHADING DRAWINGS**, illustration, 101.
- SHAFTING**, how to cut to length, description, 203.
- SHAPE OF TEETH OF WHEELS**, 130.
- SHEARING** strain, illustration, 34.
Strength, 31.
- SHEARS OF A LATHE**, The, description, 220.
- SHEAR-STEEL**, definition, 42.
- SHEAVE**, how to make a, from solid stock, description and illustration, 291.
- SHEET-IRON**, table of standard gauges, 308.
- SHELLAC VARNISH**, for drawing paper, 121.
- "SHRINKING FIT,"** description, 254.
- SIDE CUTTING TOOL**, description and illustration, 238.
- "SIDE-RAKE,"** in lathe-cutting tool, description, 234.
- SIEMEN-MARTIN STEEL**, 40.
Description, 145.
- SILICON**, an element, 24.
- SILVER**, as an element, 24.
Description, 50.
Melting-point, 64.
Specific gravity of, 57.
- SINGLE ACTION RATCHET BRACE**, description, 190.
- SINGLE GEAR LATHE**, description, 218, 219.
- SKETCH-BOOK**, description, 77.
- SKEW-GEARING**, 138.
- SKIN OF CASTINGS**, and cutting edge of tools, 287.
- SLEDGE**, or striking hammer, description and illustration, 173.
- "SLIDING FIT,"** description, 254.
- SLIDE REST**, of a lathe, description and illustration, 226.
- SLOTTED HOLDER AND DRILL**, illustration, 296.
- SLOT OR COTTER FILE**, illustration, 163.
Description, 165.
- SLOTTING** or broaching, description and illustration, 194.
- SMOOTH DOUBLE-CUT FILE**, illustration, 162.
Description, 165.
- SOAPY WATER**, use of, in turning, 286.
- SODIUM**, an element, 24.
- SOLDER** description, 50.
- SOLENIUM**, an element, 24.
- SOLID**, A, definition of, 30, 69, 107.
Or cubic measure, table of, 69.
- SPANNER-WRENCH**, description, 205.
- SPECIFIC GRAVITY**, historical note, 56.
Of bodies, 55.
- SPECIFIC GRAVITIES**, table of, 57.
- SPELLER**, description, 50.
- SPINDLE-TEMPER**, description, 147.
- SPONGE-IRON**, 37.
- SPRING DIVIDERS**, illustration, 170.
Description, 171.
- SPRING TOOL**, use of, description and illustration, 242.
- SPUR WHEEL**, description, 124, 127.
Illustration, 129.
- SQUARE**, to convert a, into an octagon, 117.
To describe a, about a circle, 115.
To inscribe a, in a circle, 115.
- SQUARE CENTER**, use of in the lathe, description and illustration, 268.
Definition of 67.
- SQUARE-FOOT**, definition, 67.
- SQUARE-ROOT**, table of, 326-330.
- SQUARES**, table of, 326-330.
- STANDARD** of wheel proportions, 136.
Or fulcrum, for ratchet drill, description and illustration, 191.
Units, definition, 65.
U. S. Bushel, 68.
U. S. Gallon, capacity of, 69.
- STATUTE MILE**, definition of, 70.
- STEADY REST**, description and illustration, 231.
For lathe, how to set and work, 231.
Illustration, 105, 106.
- STEEL**, Bessemer, 39, 40.
Cast, 41.
How to temper and harden, 143.

- STEEL**, melting point, 64.
 Process of manufacture, 39.
 Specific gravity of, 57.
 Square, description and illustration, 159.
 Straight-edge, illustration and description, 169.
 Strength of, 58.
 Tools, etc., lathe practice, 251.
- STEEL GEARS**, 138.
- STEEL RULE** and straight edge, description, 251.
- STERLING**, or English money, table of, 72.
- STILLSON WRENCH**, description, 172, 205.
 Illustration, 172.
- STOCKS AND DIES**, description and illustration, 200.
- STRAIGHT-EDGE**, and its use in surfacing, illustration, 186.
 Description, 188.
 A steel, illustration and description, 169.
- STRAIN**, definition, 33.
 Illustration, 34.
 Or thrust, in worm wheels, 131.
- STRENGTH**, tensile, 31.
- STRENGTH OF MATERIALS**, 59.
 Important principles, 60.
 Table of, 58.
- STRESS**, definition, 33.
- STRONTIUM**, an element, 24.
- SUBSTANCE**, definition of, 29.
- SULPHUR**, an element, 24.
 Description, 50.
 Melting point, 63.
 Specific gravity of, 57.
- SUMMARY** relating to the lathe, 303.
- SURFACE**, definition of, 107.
 Gauge, how to use, description, 188.
 Gauge, or scriber, illustration, 187.
 Gauge, or scriber, description, 188.
 Measures, table of, 67.
 Of the carriage of a lathe, description, 224.
 Plate, use of centering, description and illustration, 283.
 Plates and their use, description and illustration, 185.
- SURFACING AND BORING LATHE**, illustration, 248.
 Lathe, description, 218.
 Operation, description, 185.
- SWAN-NECK TOOLS**, description and illustration, 239.
- "S" WRENCH**, illustration of, IV.
- TABLE OF** aliquot parts, 70.
 Alloys, 64.
 Apothecaries' weights, 71.
 Areas of circles, 313-325.
 Avoirdupois weight, 68.
 Cast-steel, weight of, 311.
 Circular measure, 65.
 Circumferences of circles, 65, 313-325.
 Contents, VIII, IX.
 Decimal equivalents of an inch, 312.
 Degrees in circle, 65.
 Diameters of circles, 313-325.
 Dry measure, 68.
 Flat-rolled iron, weight of, 309.
 Fluid measure, 71.
 Freuch money, 72.
 Gravity, 54.
 Liquid measure, 69.
 Long measure, 67.
 Melting point of solids, 63.
 Metrical equivalents, 71.
 Money, 72.
 Nautical measures, 70.
 Plate-iron, weight of, 308.
 Principal gauges and weight of sheet-iron, 311.
 Roman figures, 66.
 Round-iron, weight of, 310.
 Sheet-iron, standard gauge, 308.
 Solid or cubic measure, 69.
 Specific gravity, 54.
 Square-iron weight of, 310.
 Square measure, 67.
 Squares, cubes, etc., 326-330.
 Strength of materials, 58.
 Sterling or English money, 72.
 Troy weight, 66.
 United States money, 72.
 Weights and measures, 65; note, 68.
 Weight of iron plate, 308.

- TAIL SPINDLE** of a lathe, description, 223.
- TAIL STOCK**, dead center, etc., description, 287.
Of a lathe, description, 222.
Of a lathe, illustration, 223.
- TANGENTS TO A CIRCLE**, to draw, 113.
- TANTALUM**, an element, 24.
- TAPER DRILL**, description, 194.
- TAPER FILE**, or three-square, illustration, 164.
Description, 166.
- TAPER TAP**, illustration, 196.
Description, 198.
- TAPER TURNING**, provisions in a lathe, 223.
- TAPPING**, the operation of, description, 198.
- TAP-WRENCHES**, description and illustration, 199.
- TEAT-DRILL**, description, 189.
- TEE-SQUARE**, description and illustration, 83.
Points relating to, 120, 121.
- TELLURIUM**, an element, 24.
- TEMPERATURE OF STEEL**, judged by color, 149.
- TEMPERING AND HARDENING** Metals, 143.
Cutting tools, description, 233.
Steel, color of oxide, 149.
Tools, rule for, 250.
- TEMPLATE**, description and illustration, 258.
- TENACITY**, definition, 33.
- TENSILE-STRAIN**, definition, 33.
Illustration, 34.
- TENSILE STRENGTH**, 31.
- TERBIUM**, an element, 24.
- THALLIUM**, an element, 24.
Description, 51.
- THORIUM**, an element, 24.
- THREADING TOOL**, description and illustration, 238.
- THREE LAWS OF MOTION**, 55.
- THREE-THROW CRANK**, turning in lathe, 284.
- THUMB-TACK**, description, 83.
- TIDE-POWER**, 23.
- TIME**, table of, 66.
- TIN**, an element, 24.
Description, 51.
Melting point, 64.
Specific gravity of, 57.
Strength of, 58.
- TITANIUM**, an element, 24.
- TOOL-CUTTING**, description, 23.
- TOOL-POST**, of a lathe, description and illustration, 230.
- TOOL ROOM**, description and use of, 245.
- TOOLS AND MACHINES**, 209.
For brass, gun metal, description, 243.
For cutting iron in the lathe, 243.
In machine practice, description, 210.
- TOOL-STEEL**, cast, description, 233.
Hardening, trade secret, 144.
Process for tempering, 143.
- TOOLS**, tempering, rule for, 250.
Temper, description, 147.
- TOOTH**, depth of, in wheels, 138.
- TOP RAKE**, in lathe cutting tool, description and illustration, 234.
- TORSIONAL STRAIN**, illustration, 34.
- TOUGH**, a quality, 31.
- TRACING DRAWINGS**, points relating to, 120.
- TRANSMISSION OF POWER**, description, 212.
- TRANSVERSE STRAIN**, illustration, 34.
- TRIANGLE**, or set-square, description, 84.
To construct a, on a given base, 113.
To describe a circle about a, 115.
To inscribe a circle in a, 116.
- TRIPLE-GEAR LATHE**, description, 219.
- TRIPLE-GEARED, SELF-ACTING, SCREW-CUTTING LATHE**, 303.
Illustrations, 216, 232.
With revolving tool-post, description, 304.
- TROY WEIGHT**, table of, 66.
- TRUNDLE WHEEL**, 126, 129.
Illustration, 137.
- TUBAL CAIN**, illustration, 250.
- TUNGSTEN**, an element, 24.
Description, 51.
- TURNING AND BORING**, 214.
Crank pins on crank shafts, description and illustration, 283, 284.

- TURNING AND BORING**, Shafts and spindles, description, 280, 281, 282.
 Shafts and spindles, illustrations, 281, 282.
 Tool for wrought iron or mild steel, description, 235.
 Work between centers of lathe, description, 273-285.
 Work between centers of lathe, illustrations, 272, 273.
 Wrist-pin between centers of lathe in practice, description and illustration, 277, 278, 279, 280.
- TURPENTINE**, use of, in cutting metals, 286.
- TWIST DRILL**, description, 189.
 How to fix in back center, description and illustration, 294.
- TWISTING-STRAIN**, illustration, 34.
- UNITED STATES STANDARD SCREW THREAD**, description and illustration, 197.
- UNIT OF LENGTH**, definition, 65.
- UNIT OF SURFACE**, definition, 65.
- URANIUM**, an element, 24.
- USEFUL TABLES for Machinists**, 308.
 Of weights and measures, 65.
- VANADIUM**, an element, 24.
- VERTICAL DRILL**, description, 189.
- WISE**, advantages aimed at in selecting, 174.
 And bench, practice, description, 174.
 Caps, or jaw protectors, 175.
 Description, 154.
 Illustrations, 153, 155.
 Manipulation of work in, 174, 175.
- WALL-DRILL**, description, 189.
- WATER-POWER**, 23.
- WEDGE**, 23, 211.
- WEIGHT OF A BODY**, 54.
- WEIGHTS AND MEASURES**, 65.
 Note, 68.
- WELDABLE**, definition, 32.
- WHEEL and axle**, 23, 211.
 Bevel, description of, 124, 127.
 Helical, illustration, 132.
 Internal-gear, illustration, 133.
 Miter, illustrations, 125, 127.
 Spur, description of, 124, 127.
- WHEELS in gear**, illustration, 128.
 Speed of cast iron and steel, 139.
- WHITE IRON**, 38.
- WHITWORTH STANDARD SCREW THREAD**, description and illustration, 197.
- WIND-POWER**, 23.
- WIRE**, strength of, 58.
- WORK**, how to, 19.
- WORK-BENCH**, description, 150.
 Illustrations, 140, 151.
- WORKING DRAWINGS**, how to read, 104.
 Illustrations, 105, 106.
 Of headstock of lathe, description and illustration, 302.
- WORKING OR SLIDING FIT**, description, 253.
- WORM-WHEEL**, description, 130.
 Illustration, 132.
 Strain and friction, 131.
- WRENCH**, alligator, description and illustration, 205.
- WRENCHES**, and their use, description, 203, 204.
 "Monkey," description, 171; illustration, 172.
 Monkey, description and illustration, 205.
 Stillson, description and illustration, 172.
- WROUGHT-IRON**, 39.
 Turning, cutting tool for, 237.
- YTTERBIUM**, an element, 24.
- ZINC**, an element, 24.
 Description, 51.
 Melting point, 64.
 Specific gravity of, 57.
- ZINCONIUM**, an element, 24.

MECHANICAL BOOK LIST.

The following is a list of mechanical works published by THEO. AUDEL & Co., 63 Fifth Avenue, New York, any of which will be sent postpaid upon receipt of price. Mark books desired (X):

(X)
Cross
Here.

HAWKINS' MECHANICAL DICTIONARY.

A cyclopedia of words, terms and phrases in use in the Mechanic Arts, Trades and Sciences—"many books in one." It is the one book of reference no student or expert can dispense with. 704 pages, 6½x8½ inches, handsomely bound.

\$3.50

HAWKINS'-LUCAS' MARINE ENGINEERING.

This treatise is the most complete published for the practical engineer, covering as it does a course in mathematics, the management of marine engines, boilers, pumps, and all auxiliary apparatus, *the accepted rules for figuring the safety-valve*. More than 1,000 ready references, 807 Questions on practical marine engineering are fully answered and explained, thus forming a ready guide in solving the difficulties and problems which so often arise in this profession.

\$2

HOMANS' MOTOR CAR PRACTICE.

Gives full details of the successful care, handling and locating of automobile trouble.

Thoroughly teaches the first necessary principles and afterwards the methods and practices used in every part of even the most complicated Motor Car.

It forms a complete course in the *Science of Motoring* and is highly approved by *Manufacturers, Owners, Operators and Repairmen* everywhere.

\$2

AUDEL'S GAS ENGINE MANUAL.

This new volume gives the latest and most helpful information respecting the construction, care, management and uses of *Gas, Gasoline and Oil Engines, Marine Motors and Automobile Engines*, including chapters on *Producer Gas Plants* and the *Alcohol Motor*.

The book is a practical educator from cover to cover and is worth many times its price to any one using these motive powers.

\$2

ROGERS' ERECTING AND OPERATING.

Provides full information on methods successfully proved in modern practice to be the best for use in erecting and installing heavy machinery of all kinds. It includes a systematic course of study and instruction in *Mill Engineering* and *Millwrighting*, together with time saving tables, diagrams and a quick reference index.

\$3

ROGERS' DRAWING AND DESIGN.

This volume is arranged as a comprehensive, self-instruction course for both shop and draughting room.

Contains 506 pages, illustrated by over 600 cuts and diagrams, very many of them full page drawings; the book is printed on a very fine grade of paper; it measures 8½x10½ inches and weighs over 3 pounds; it is in every way completely up-to-date.

\$3

ROGERS' PROGRESSIVE MACHINIST.

Is a manual for Machinists and Engineers on modern machine shop practice, treating specially on gearing, turning and lathe work, hardening and tempering, bench and vise work, handling and working of machine tools, etc. Its utility has been demonstrated in thousands of instances.

\$2

ROGERS' ADVANCED MACHINIST.

Gives practical and useful information on measuring instruments, lathe and screw cutting machines, boring machines and how used, milling and grinding machines, grinding, punching and shearing, bolt cutting, specialty machines and shop appliances, shop management, work shop receipts, shop arithmetic, reference tables, etc., making it a most valuable guide and reference work for the practical machinist.

\$2

ROGERS' PUMPS AND HYDRAULICS. [2 Vols.]

This complete and practical work treats exhaustively on the construction, operation, care and management of all types of Pumping Machinery. The basic principles of Hydraulics are minutely and thoroughly explained. It is illustrated with cuts, plans, diagrams and drawings of work actually constructed and in operation and all rules and explanations given are those of the most modern practice in successful daily use. Issued in 2 Volumes.

\$4

Address

Name

MECHANICAL BOOK LIST.

The following is a list of mechanical works published by **THEO. AUDEL & Co.**, 63 Fifth Avenue, New York, any of which will be sent postpaid upon receipt of price. Mark books desired (X):

(X) Cross Here.	<p>HOMANS' TELEPHONE ENGINEERING.</p> <p>Is a book valuable to all persons interested in this ever-increasing industry. No expense has been spared by the publishers, or pains by the author, in making it the most comprehensive handbook ever brought out relating to the telephone, its construction, installation and successful maintenance.</p>	\$1
—	<p>HAWKINS' ELECTRICITY FOR ENGINEERS.</p> <p>The introduction of electrical machinery in almost every power plant has created a great demand for competent engineers and others having a knowledge of electricity and capable of operating or supervising the running of electrical machinery. To such persons this pocket-book will be found a great benefactor, since it contains just the information required, clearly explained in a practical manner.</p> <p>It contains 550 pages with 300 illustrations of electrical appliances, and is bound in heavy red leather, size 4½x6½ for the pocket.</p>	\$2
—	<p>HAWKINS' CALCULATIONS FOR ENGINEERS.</p> <p>The Hand Book or Calculations is a work of instruction and reference relating to the steam engine, the steam boiler, etc., and has been said to contain every calculation, rule and table necessary for the Engineer, Fireman and Steam User.</p> <p>It is a complete course in Mathematics. All calculations are in plain arithmetical figures, so that they can be understood at a glance.</p>	\$2
—	<p>HAWKINS' STEAM ENGINE INDICATOR.</p> <p>This work is designed for the use of erecting and operating engineers, superintendents and students of steam engineering, relating, as it does, to the economical use of steam.</p> <p>The work is profusely illustrated with working cards taken from every day use, and gives many plain and valuable lessons derived from the diagrams.</p>	\$1
—	<p>HAWKINS' STEAM ENGINE CATECHISM.</p> <p>This work is gotten up to fill a long-felt need for a practical book. It gives directions and detailed descriptions for running the various types of steam engines in use.</p> <p>The book also treats generously upon Marine, Locomotive and Gas Engines, and will be found valuable to all users of these motive powers.</p>	\$2
—	<p>HAWKINS' STEAM BOILER PRACTICE.</p> <p>This instructive book on <i>Boiler Room Practice</i> is indispensable to Firemen, Engineers and all others wishing to perfect themselves in this important branch of Steam Engineering.</p> <p>Besides a full descriptive treatise on Stationary, Marine and Locomotive boilers, it contains sixty management cautions, all necessary rules and specifications for boilers, riveting, bracing, finding pressure, strain on bolts, etc., thus being a complete handbook on the subject.</p>	\$2
—	<p>HAWKINS' ENGINEERS' EXAMINATIONS.</p> <p>This work is an important aid to engineers of all grades, and is undoubtedly the most helpful ever issued relating to a safe and sure preparation for examination. It presents in a question and answer form the most approved practice in the care and management of Steam Boilers, Engines, Pumps, Electrical and Refrigerating Machines, together with much operative information useful to the student.</p>	\$2
—	<p>HAWKINS' MECHANICAL DRAWING.</p> <p>This work is arranged according to the correct principles of the art of drawing; each theme being clearly illustrated to aid the student to ready and rapid comprehension.</p> <p>It contains 320 pages with over 300 illustrations including useful diagrams and suggestions in drawings for practice. Handsomely bound in dark green cloth. Size 7x10 inches.</p>	\$2

Address

Name

DRAWING TOOLS, \$3

"Every man has his work to do in this world," says the philosopher, "and the tools go to him who can use them."

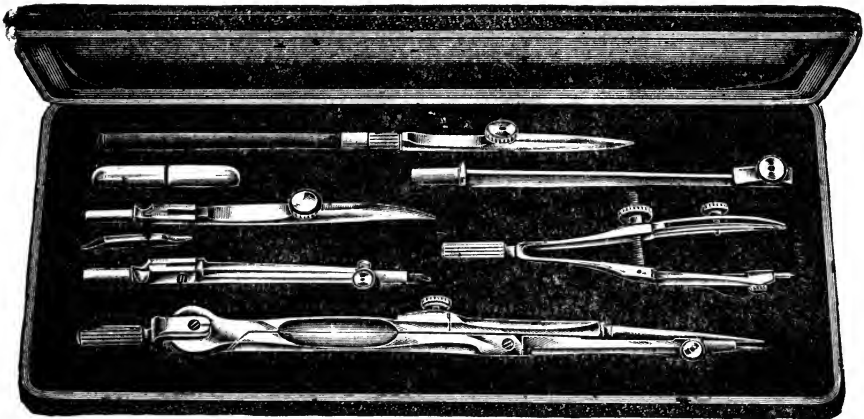

This set of German silver drawing tools, in pocket case, as here shown, contains $5\frac{1}{2}$ -inch compasses, with handle; fixed needle point, with pen and pencil points, and lengthening bar; spring bow pen, $3\frac{1}{2}$ -inch; spring nib ruling pen; box of leads; making a most handy "outfit" for the engineer or machinist.

Complete Drawing Outfits, \$4

This outfit consists of the following high-class articles: One 24-inch T Square; One 11-inch Triangle; One 9-inch Triangle; One Hardwood Curve; One 12-inch Triangular Boxwood Scale; One Protractor; One Drawing Board, 18x23 inches; Two Drawing Pencils; Eraser; Thumb Tacks; Bottle of Drawing Ink; Pencil Pointer and One Dozen Sheets Universal Drawing Paper, size 15x20 ins.

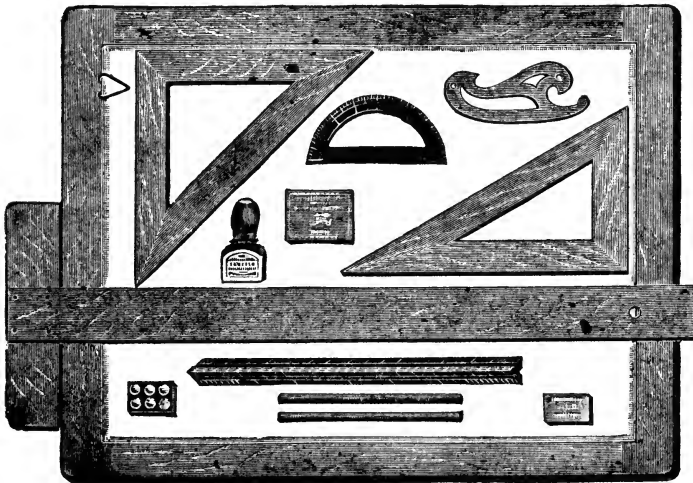

This outfit will be delivered to any address in the United States, transportation pre-paid, upon receipt of above price

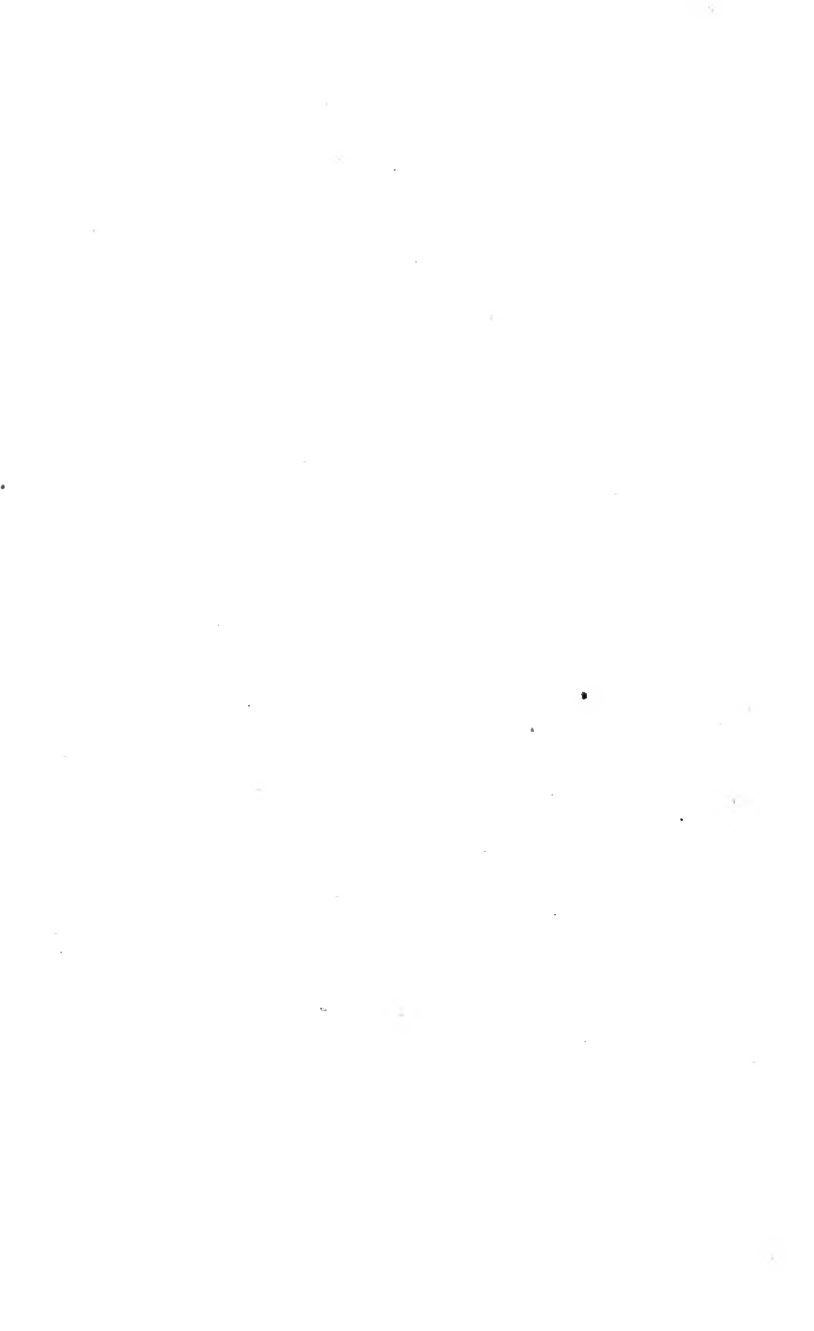

RETURN TO the circulation desk of any
University of California Library

or to the

NORTHERN REGIONAL LIBRARY FACILITY
Bldg. 400, Richmond Field Station
University of California
Richmond, CA 94804-4698

ALL BOOKS MAY BE RECALLED AFTER 7 DAYS

- 2-month loans may be renewed by calling
(510)642-6753
- 1-year loans may be recharged by bringing
books to NRLF
- Renewals and recharges may be made
4 days prior to due date

DUE AS STAMPED BELOW

JUL 26 2003

DD20 15M 4-02

U.C. BERKELEY LIBRARIES



C020911795

