

UC-NRLF



\$B 54 724

LIBRARY
OF THE
UNIVERSITY OF CALIFORNIA.

RECEIVED BY EXCHANGE

Class **Educ. Dept.**

1901





THE PSYCHOLOGY OF READING

AN EXPERIMENTAL STUDY OF
THE READING PAUSES AND
MOVEMENTS OF THE EYE

BY

WALTER FENNO DEARBORN, A. M.

Submitted in Partial Fulfillment of the Requirements
for the Degree of Doctor of Philosophy
in the Faculty of Philosophy
Columbia University



RE-PRINTED FROM THE

ARCHIVES OF
PHILOSOPHY, PSYCHOLOGY AND SCIENTIFIC METHODS

EDITED BY

J. MCKEEN CATTELL AND FREDERICK J. E. WOODBRIDGE

NO. 4, MARCH, 1906

Columbia University Contributions to Philosophy and Psychology, Vol. XIV., No. 1

BF456
R2D4

Educ. Dept.

CONTENTS.

CHAPTER		PAGE
I	INTRODUCTION.....	7
II	HISTORICAL SUMMARY.....	9
III	METHODS AND RECORDS.....	13
	§ 1. METHODS AND APPARATUS.....	13
	§ 2. EXPLANATION OF RECORDS AND THE METHOD OF MEASUREMENT.....	16
	§ 3. DESCRIPTION OF ACCOMPANYING PHOTOGRAPHS.....	19
IV	THE FIXATION PAUSES.....	23
	§ 1. THE NUMBER OF FIXATION PAUSES AND THE EXTENT OF PAGE READ PER FIXATION.....	23
	§ 2. MOTOR HABITS.....	29
	§ 3. REFIXATIONS.....	30
V	IS THERE PERCEPTION DURING EYE MOVEMENT?.....	42
VI	THE DISTRIBUTION OF ATTENTION IN PERCEPTION.....	48
VII	VISUAL PROCESSES INVOLVED IN RECOLLECTING.....	57
VIII	THE DURATION OF THE FIXATION PAUSES.....	59
	§ 1. RELATION TO THE NUMBER OF PAUSES.....	59
	§ 2. THE LENGTH OF FIXATION AND THE REACTION TIME OF THE EYE.....	61
IX	THE SPAN OF ATTENTION AND THE DURATION OF PAUSES.....	62
	§ 1. EXPERIMENTAL ISOLATION OF THE READING PAUSES...	65
X	THE NUMBER SPAN OF ATTENTION.....	67
XI	THE LOCATION OF THE FIXATION PAUSES.....	74
	§ 1. THE LOCATION OF PAUSES IN ORDINARY READING.....	74
	§ 2. PROOF READING, EFFECT OF ARTICULATION, ETC.....	91
	§ 3. CHILDREN'S READING.....	96
	§ 4. THE EFFECT OF LONG AND SHORT WORDS.....	98
XII	THE LENGTH OF TEXT LINES AND MOTOR HABITS.....	99
XIII	RAPIDITY OF READING.....	116
XIV	THE FATIGUE OF THE EYES IN READING.....	123
XV	SUMMARY AND CONCLUSIONS.....	128
	APPENDIX.....	133
	ACKNOWLEDGEMENTS.....	135

INDEX OF PLATES

PLATE	PAGE
I LINE DRAWING OF APPARATUS.....	Opposite Page 13
II THE READING MOVEMENTS OF SEVEN SUBJECTS	Opposite Page 17
III REFIXATIONS.....	Opposite Page 35
IV TACHISTOSCOPIC READING, ETC.....	Opposite Page 55
V READING OF NUMERALS, CHILDREN'S READING, ETC	Opposite Page 73

INDEX OF CHARTS OF THE LOCATIONS OF FIXATION PAUSES

CHART	PAGE
I — II	75 — 80
III — VI	81 — 82
VII — XI	87 — 89
XII — XVI	92 — 95
XVII	97
XVIII — XXII	101 — 105
XXIII	119



THE PSYCHOLOGY OF READING

CHAPTER I

INTRODUCTION

The motor tendency or actual movement of the eyes in response to changes in the direction of thought, as in the imagining and recall of different extents of space and locality, has been a particularly good illustration of the ideomotor theory of mental action. The significance, however, of the fact itself for a general study of the intellectual processes involved has been but little appreciated. The relation is well exemplified in the reading movements of the eyes, their automatic and reflex character and their usual freedom from voluntary control making the dependence particularly close and worthy of study. These movements are not only subject to the influence of the direction of thought as words and phrases are read and assimilated, but they are also directly concerned in the sensory processes of perception. The peculiarly jerky and interrupted form of movement, which is more exactly a series of alternate pauses and movements, is due in part both to the requirements of apperception and assimilation, and to the physiological limitations of perception. This twofold relation of these movements to central activities, on the one hand, and, on the other hand, as the necessary accessory to a peripheral organ of sensation, gives them an intermediary position between sensation and recognition and between thought and motor expression, which is of particular interest for the cues or indices which a study of them may give of some of the workings of the mind.

If, for example, the attention pauses upon some word or phrase, singles out some misspelling, passes hurriedly over a commonplace of thought or a familiar phrase, or again lingers on the difficult parts of the sentence, we shall find some indication, at least, of these facts in the varying duration of the pauses and in peculiarities of the movements of the eye. If, in the second place, there are among the diversity of methods of printing and the ingenious devices and arrangements of the printer some which are naturally better suited to the physiological limitations of vision, it is to be expected that differences in the ease and rapidity of eye movement may point to

some of the unnecessary difficulties which the printer has imposed. The reading movement will be found to have the characteristics of habits acquired to meet artificial conditions, adjustable to the varying extents of angular displacement of the eye, etc., but less adaptable to some typographical methods and arrangements than to others.

In the next place, individual peculiarities of different readers also make a careful analysis and description of the eye movements desirable. There are, for instance, differences in the span or distribution of attention which are correlated with motor peculiarities, and dependent upon differences in the ease of acquirement of the above noted motor habit of reaction. They are further illustrated in motor differences between fast and very slow readers, and between children and adults.

The primary object of this investigation is, therefore, to determine with exactness the form and character of the movement of the eye in reading, and to define or plot the positions on the page which correspond to the so-called fixation or reading pauses of the eye. A more detailed and accurate analysis of the physiological factors of the reading process is desirable for the reasons above assigned, and is in many respects essential to future study of the psychology of reading. Since it is mainly, if not solely, during the pauses that the eye is susceptible to significant stimulation,¹ a knowledge of where these pauses are made relative to the page that is being read, and what the conditioning factors are which determine their location, should furnish a better basis for the study of the problems of reading than has yet been available. The questions, therefore, concerning the perception and recognition of words and sentences, the typographical and more purely physiological factors which impede or aid in reading, the basis of the individual differences in the rapidity of reading and other related problems will be discussed in reference to the data thus obtained.

In Chapter II an historical summary is made of the parts of the work of earlier investigators which bear directly upon the experiments of this investigation. The more general literature of reading will be discussed as occasion demands in relation to the special problems raised and in connection with my own experiments.

¹ B. Erdmann and R. Dodge, *Psychologische Untersuchungen über das Lesen auf Experimenteller Grundlage*. Halle. 1898.

CHAPTER II

HISTORICAL SUMMARY

The introspective evidence of what the eye does in reading is ordinarily very meager, although there is much here to show that the differences among individuals are much greater than has been suspected. Most of us are vaguely aware of the sensation of the return sweep of the eye from the end of one line to the beginning of the next line, but have no feeling at all—even when the attention is directed to the process—of the movement as the line is read.¹

Lamare and Javal² seem to have been the first to record the observation that the movement of the eye in reading was by little jerks and not a continuous movement across the page. By means of a sound attachment to the upper eye-lid they were able to count roughly the number of these little jerks by the faint sound which was made as the eye-ball moved against the eye-lid.³ Landolt studied these movements by direct observation of the eye. "He had his subjects read slowly and was thus able to count the jerks. He found that an average of one and fifty-five hundredths words were read per fixation at a distance of 30 cm. Reading of a for-

¹ Erdmann and Dodge (Op. cit., Chap. I) cite an instance which is probably by no means common, where the movement was felt as a series of rhythmically interrupted movements and the interesting suggestion is made that the local sign theory of Lotze gives evidence of such a highly developed motor consciousness. It is not improbable that our motor theories of feelings of innervation have a similar individualistic basis.

² *Annales d'Oculistique*, 1879, Tome LXXXII, p. 252 (note).

"D'après des recherches entreprises par M. Lamare dans notre laboratoire l'oeil subit même plusieurs saccades dans le courant de chaque ligne, environ une par 15 à 18 lettres de texte, il est probable que chez le myope, à chacune de ces saccades de l'oeil répond une variation brusque de l'accommodation."

No evidence has been adduced to support this assumption of Javal, that there is a change of accommodation with every 'jump' of the eye. This is certainly not the explanation or cause of the halting movement of the eye,—as might be implied by this statement, because, of course, movements of the widest extent can be made without 'halting.' The explanation is, doubtless, that proposed by Erdmann and Dodge, i. e., the lack of perception during movement. It may be further questioned whether a change of accommodation occurs at every pause. The change in accommodation after a large angular displacement of the eye must, of course, be greater than after a small movement, and the time necessary to make this adjustment in the former case would presumably be longer, but this is not found to be the case.

³ Compare Huey, *American Journal of Psychology*, XI, p. 286.

eign language required more fixations, as did the reading of disconnected words, of numbers, and of lists of proper nouns."¹

These interesting observations were further extended and first given significance by the extensive investigations of Erdmann and Dodge.² By a similar method of direct observation, the movements of the reader's eye were recorded from the reflection in a mirror. It was found that an average of five fixation pauses per line was made by one subject (D) in reading a page from Locke's *Essay*, (width of line 8.3 cm.) and an average of eight pauses per line was made by E in reading from Helmholtz's *Physiol. Optik*, (width of line 12.2 cm.). The variations from this average were small. The main conclusions from their varied experiments are the following: A larger number of pauses are made in difficult than in comparatively simple narration, and the simpler the text the more nearly equal are the pauses and movements. Similarly a longer time and more pauses are necessary to read a foreign language than to read one's own language. The same is true when the attention is directed to the text, as in proof-reading. The average angle of movement between two successive pauses varied from 3° 54' to 5° for difficult or unfamiliar passages of the above cited books, and from 4° 14' to 5° 36' for familiar passages. That is, in either case³ the eye does not reach to the very edge of the line, but the first and last fixations fall within the line. The first fixation comes nearer to the beginning of the line than the last fixation to the end of the line. This distance, as the angle of movement shows, is lessened in the more difficult reading.

On the basis of the measurement by Dodge, by the Lamansky method, of the angular velocity of the eye's movements, and on the assumption that this velocity holds good for the movements of the eye in reading, it is argued that from $\frac{1}{3}$ to $\frac{2}{3}$ (according to the individual) of the reading time is consumed by fixations, and that the recognition of letters is not possible in the remaining short intervals of time, and must, therefore, take place only during the fixation pause proper. This conclusion is of first importance for the theory and further study of perception during reading. The experiments and reasoning on which it is based will be presented in detail and discussed in a succeeding section, in connection with further measurements of the relative duration of fixation pauses and movements proper.

¹ Quoted from Huey, Vol. XI, p. 286. The article of Landolt ("Archives D'Ophthalmologie, II (1891) pp. 385-395) was not accessible to me at the time of writing.

² *Op. cit.*, Chap. I, pp. 36-76.

³ *Op. cit.*, Chap. II.

The first successful attempt at direct registration of the movements of the eye and the first exact measurements of the number and duration of the fixation pauses were made by Huey.¹

Huey recorded the movements of the eye by a direct attachment of a plaster of Paris eye-cup and aluminum pointer (Delabarre eye-cup) to the cornea of the reader's eye. The records were made upon the smoked drum of a kymograph, upon which also a time record was written. The weight and inconvenience of the eye-cup was not believed by the writer and his subject to interfere seriously with the conditions of normal reading. The average number of fixations per line in 30 lines of the *American Journal of Psychology* thus recorded was found for two subjects to be 4.8 (M. V. .5) and 4.5 (M. V. .6). These readings were about the ordinary distance (33-35 cm.) from the eye. Doubling this distance did not increase the number of fixations and decreasing the size of type (from 10 to 8 point) had but little effect. The velocity of movement for the average interfixation arc (the latter was found to be from 3° 21' to 4° 14') is given as 41.8 σ to 48 σ . The mean variation is estimated at not more than 5%-6%. The time occupied in the reading pauses is naturally found to be much more variable. The average of one passage was 190.9 σ with a mean variation of 48.6 σ . The increase in the speed of reading is brought about "solely, or at least mainly, by decreasing the number and duration of the reading pauses." The average number of words read per fixation in lines of different lengths varying from 121 mm. to 21 mm. show a slight advantage for the short line. The largest number of words (3.63) was read in a line of 60.5 mm. in length, but there is very considerable variation and no attempt was made to analyze further the cause for these differences.

In these experiments of Erdmann and Dodge and Huey as well as in investigations of Cattell,² Zeitler,³ and others, and more recently of Messmer⁴ and Becker⁵ with the fall chronometer and tachistoscope, the differences between the extent of the field of apperceptive attention in reading and the psychological possibilities of perception have been emphasized. While it is possible, as has been shown by these investigators, to see the whole of a line of about the width of this page in from two to three separate exposures, the number of fixations ordinarily made is at least double that number. One of the more evident reasons for this difference

¹ *American Journal of Psychology*, Vols. X, XI and XII.

² Cattell, *Phil. Studien*, II and III, *Mind*, XI, *Brain*, VIII.

³ Zeitler, *Phil. Studien*, XVI, 380-465.

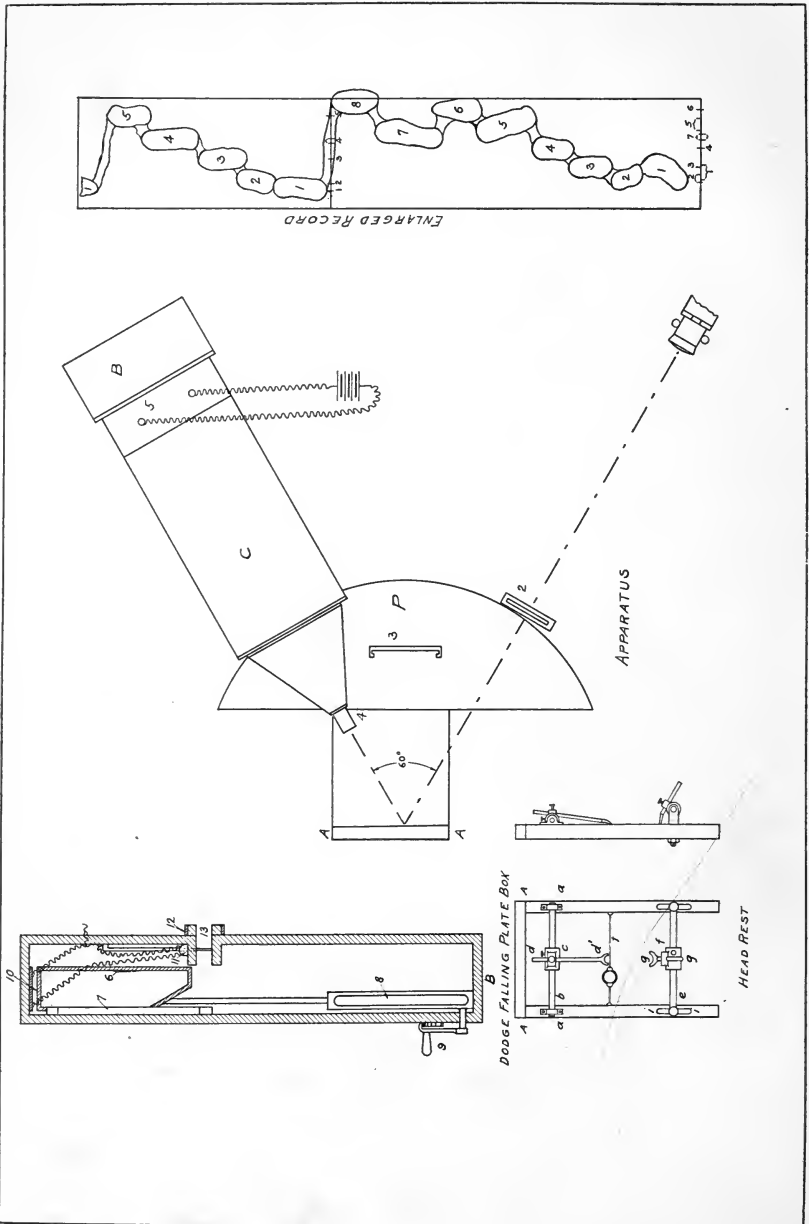
⁴ *Archiv Messmer, für die Gesamte Psychologie*, Bd. II, Heft, 2 u. 3.

⁵ Becker, *Zeitschrift für Psychologie u. Physiologie der Sinnesorgane*, Bd. 36, Heft, 1 u. 2.

is that in reading the recognition and assimilation of words must go on at the same time that the sensations are received, whereas in the experiments with the fall exposure apparatus the former processes are completed only after the end of the period of sensory excitation. But, even thus, it is quite conceivable that the eye might single out the two or three most advantageous positions in the line for perception and remain there until the words read were sufficiently well recognized and understood, and then proceed to the next point of vantage. Such a procedure would give a regular and uniform mode of reaction, and if we wished to teach our children how best to read, the physiological difficulties which at present receive little attention would perhaps be overcome, when we had trained a series of motor habits which would vary only or mainly according to the different lengths of line. That the actual method of reading is quite different from this is no evidence that it is the best or only possible way. It is certain that reading on its physiological side at least is artificial to the extent that it is dependent on conditions that have been developed with little direct reference to the physiology or psychology of vision. What the effect is of some of these latter conditions upon the more purely cognitive and perceptive processes can perhaps be determined by a more detailed analysis of the eye movements. The average lengths, general location of the fixation pauses, and the average rate of movement have been given in the works already outlined, but before many of these questions regarding the reading process can be answered with any certainty, it will be necessary to plot the location of the separate pauses with greater accuracy, and to compare the lengths of the individual pauses,—when the various characteristics of the printed page and its subject matter are varied under experimental conditions,—with the apperceptive character of the words being read. This has been attempted in the following pages. The methods and apparatus and the limits of accuracy of the measurements are discussed in the following section.



PLATE I



CHAPTER III

METHODS AND RECORDS

§ 1. *Methods and Apparatus*

The means which have been employed for registering the movements of the eye is the photographic method of Prof. R. Dodge, and the apparatus (Cf. Plate I) used is a modification of the Dodge falling plate camera.¹ Photographs are made by this method not of the movement of the eyeball itself, as such photographs are not

DESCRIPTION OF APPARATUS. PLATE I.

APPARATUS. Line drawing, as seen from above. AA, head rest. B, Dodge falling plate box. C, extension bellows. P, perimeter. The pencil of light from the lantern passes through plates of blue glass (2), and is reflected from the cornea into the lens of the camera (4). 3. Book rest. 5. Electrical connections with magnet of spring pendulum.

B. DODGE FALLING PLATE BOX, as seen with side of box removed. 6. Plate holder. It is supported by a piston rod which plays into cylinder of oil, and is released in its fall by opening a valve (a) in the bottom of the cylinder. As fast as the oil is forced out, it is returned by means of a vent pipe (8) into the top of the cylinder. Any lateral movement of the plate is 'taken up' by a spring and guiding rails (7). The sensitive plate is successively exposed as it passes by the aperture (13). The fall of the plate breaks the electrical connection at (10) and releases the spring pendulum from its magnet (11).

AA. HEAD REST. See text for description.

ENLARGED RECORD. The original record was enlarged about twenty times. This drawing has been reduced in reproduction about ten times so that it represents an actual enlargement of the original record of about two times (cf. text).

sufficiently differentiated to admit of exact measurement, but of the movements of the corneal reflection; that is, the eye itself is not directly photographed, but the records on the negative are of the reflection from the eccentric surface of the cornea of a bright pencil of light which is thrown upon the eye from the reflecting mirror of a heliostat, or from some other source of light. The direct rays of an arc-light made parallel by means of intercepting lenses were, because of their greater constancy and adaptability, mainly used in these experiments.² The experiments could then

¹ For description of the original apparatus and methods see the *Psychological Review*, Vol. VIII, pp. 147-151, and in more recent form in the *American Journal of Physiology*, Vol. VIII, pp. 308-310.

² The light was passed through plates of blue glass, as that added to the comfort of the reader and admitted the actinic rays.

be equally well made by daylight or in a darkened room. The light was placed at an angle of 30° to the right of the primary line of regard of the eye, and in the same horizontal plane as the eye. The camera itself stood at a corresponding angle to the left of the subject, and the pages or books to be read were then held in a book rest at a convenient distance (about 30 cm.) directly in front, so that the angular excursions of the eye to the right and left were about equal. The reading matter also could be illuminated either by daylight or artificial light as desired. The reading was binocular, but the photographs were made of the right eye only.

The records are continuous photographs of the horizontal movements of the corneal reflection made upon a slowly falling photographic plate of great sensitiveness.

The position of the source of light must be so adjusted, and the eye of the reader brought into such a position before the camera that, if a horizontal plane be drawn from the centre of the light, it will bisect the middle of the pupil, coincide with the line representing the horizontal meridian of the eye, and pass through a horizontal slit cut in the box of the camera to admit light to the sensitive film. It was not necessary in the investigation to determine the actual extent of the movement of the eye-ball itself, provided the corneal reflection might be considered a true representation of that movement. That this is the case for a limited area of the normal eye Prof. Dodge has demonstrated in an as yet unpublished article. (See report of the Proceedings of the Am. Psych. Ass. at Phila., Dec., 1904. The *Jour. of Phil. Psych. and Scient. Methods*, Vol. II, No. 3, or the *Psych. Bulletin*, Feb., 1905. He has shown that in the normal eye the mesial eccentric surface of the cornea is a true optical surface presenting no irregularities and approximates very closely the spherical form. The arc of movement in reading the ordinary length of line is a comparatively small one, and it has been possible to keep the reflection at the center of the cornea, for the shorter lines it does not pass beyond the part of the cornea above the pupil and never reaches to the junction of the cornea with the sclerotic, where the inaccuracies are marked.

The plate holder of the camera is the most important part of the apparatus. It is, as just said, movable in the vertical plane, and in its present form is capable of most finely adjusted and uniform rates of motion. "In the original apparatus, the plate holder [6], was attached to the rod of a piston playing in a cylindrical air compressor [8]; the plate could fall only as the air escaped from the cylinder, and the velocity of the fall was regulated by the size of

the opening through which the air escaped. Slight oscillations in the velocity of the fall, owing to the elasticity of the air, suggested the use of a fluid resistance. The loss of head which would naturally result as the fluid was forced out of the cylinder, was obviated by leading the vent pipe into the top of the cylinder, and thus returning the oil as fast as it was forced out, maintaining a constant volume in the cylinder and rendering the whole device automatic and clean.¹ As there must be absolutely no lateral play during the downward movement, a small wheel is attached to each side of the holder, and they, in turn, are carefully fitted to guiding rails. Any lateral motion is 'taken up' by a small spring to which one of the wheels is fastened. The rate of fall is governed by the amount of oil that is allowed to flow through the valve.

The time of the eye's movement is also recorded upon the falling plate by means of the oscillations of a spring pendulum which is released from a magnet by a break in the electric current, caused by the initial movement of the plate. The pendulum vibrates directly behind and at the edge of the horizontal slit of the camera, and the time line is made by the alternate admission and exclusion of light. The rate of vibration of the pendulum is accurately determined by comparison with a similar record of the vibrations of a tuning fork (100 per sec.). This comparison needs to be made but infrequently as long as the length of the pendulum remains constant.

Only one other feature of the apparatus needs further description. The failure to exclude small head movements, as will be noted later, caused considerable difficulty in the experiments. Several forms of head rests and various schemes were tried, the most satisfactory being secured by modifications of the Helmholtz head rest and mouth piece.¹ The head rest proper was cut out of a single piece of heavy oak board and securely fastened to the large firm table upon which the camera rested, and also to the camera itself. In order to secure greater steadiness and firmness the support on which the camera was constructed and to which the head rest was attached was cut from a heavy two inch plank. This was in turn securely clamped to the table. On each of the uprights of the head rest *AA*, two spools of solid brass were fastened, *aa* and *ee*. The two upper and the two lower were connected by a strong brass rod on which spools of brass were slipped (*c*) and (*f*). These could be moved along the bars *b* and *e*. Through these brass blocks holes were drilled at right angles to the cross rod *b* and *e*

¹ Op. cit. *American Journal of Physiology*, VIII, p. 310.

¹ Several of the improvements are due to the kind suggestions of Professor Dodge.

and small rods inserted which could be moved up and down and were secured by thumb screws. To the end of the upper rod (*d d'*) a cross piece or 'bridge' was fastened which could be adjusted to fit over the bridge of the nose much like a pair of spectacles. On the end of the lower rod was clamped a mouth piece with wax impression. This was so made that it could reach to the back teeth and be held securely. The bridge piece and mouth piece when rightly adjusted served much like a vise. The whole mouth piece and connections could finally be moved vertically in the slot *ii* and securely clamped by the thumb screws at the desired height, i. e., so as to bring the eye of the subject on line with the camera. Complete adjustments in all directions were thus attained, together with the necessary solidity and steadiness. A 'finder' in the form of a spectacle loop (*t*) facilitated in securing the right position for the eye, and was found very useful in working with children. The 'finder' could be removed when the proper position was secured. The head 'rest' is somewhat needlessly complicated, due to home construction.

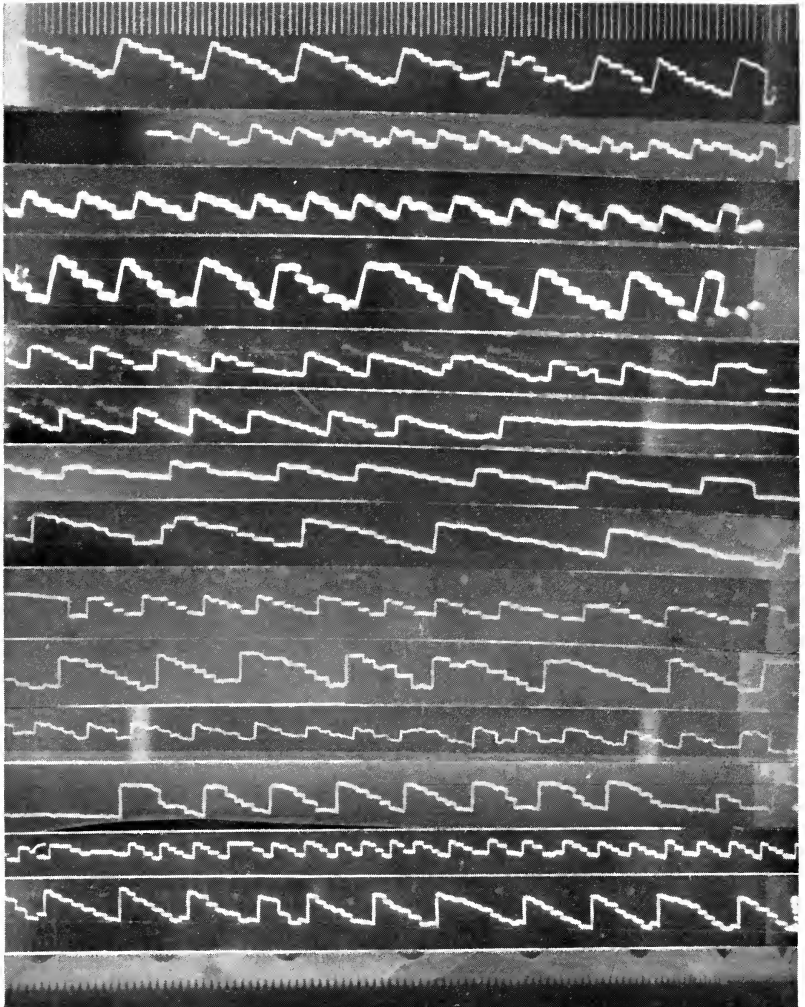
§ 2. *Explanation of Records and the Method of Measurement*

If the eye were held immovable during the exposure of the sensitive plate, the record on the negative would be a single straight vertical line reaching from top to bottom. Any horizontal movement of the eye to the right or left would, on the other hand, be represented by an oblique line. *In the accompanying plates* (See Plates II and V), *therefore, the short straight vertical lines represent the momentary pauses of the eye in reading, and the short oblique or nearly horizontal lines the interconnecting eye movements. The long oblique or nearly horizontal lines which separate the vertical lines into groups of three or more are the return sweeps of the eye from the end of one line to the beginning of the next.*

The extent of the eye's movement was magnified on the negative about four times. This was accomplished in the apparatus, as constructed for these experiments, by extending the bellows of the camera several times the focal length of the lens. The angular displacement of the eyes as well as the magnifying power of the lens were thus utilized. The incidental disadvantage of increasing the size of the pencil of rays reflected from the eye and thus securing a wide and clumsy line for measurement was overcome by excluding with the diaphragm all but a small bundle of rays crossing through the center of the lens. A very fine line capable of exact measurement was thus obtained, and at the same time the contrivance had the advantage of allowing larger units of measure-



PLATE II



ment than the actual extent of the movement of the corneal reflection.

The horizontal distances on the negative which represent the arc of movement of the eye from one edge of the print to the other, i. e., from the beginning to the end of the line, were deter-

DESCRIPTION OF PLATE II.

(The records are one-half the size of the original.)

Column I. Comparison of the vibrations of a Koenig tuning-fork (vibrating at the rate of 100 beats per second, cf. Plate III, 2) with the oscillations of the spring pendulum of apparatus which appear on the right.

2.	Subject	T.	Record	No. 1A.	reading	'A license for promotion' etc.
3.	"	T.	"	"	2B.	" Newspaper column, 'St. Petersburg' etc.
4.	"	H.	"	"	33B.	" Evolutionary thought etc.
5.	"	H.	"	"	13B.	" Newspaper column, 'St. Petersburg' etc.
6.	"	S.	"	"	41B.	" 'A license for promotion' etc.
7.	"	S.	"	"	43A.	" Newspaper column, 'St. Petersburg' etc.
8.	"	F.	"	"	49B.	" 'A license for promotion' etc.
9.	"	F.	"	"	49A.	" Newspaper column, 'St. Petersburg' etc.
10.	"	M.	"	"	50A.	" Newspaper column, 'St. Petersburg' etc.
11.	"	M.	"	"	50B.	" Newspaper column, (second reading).
12.	"	St.	"	"	63A.	" 'The boatswain' etc., (long line).
13.	"	St.	"	"	63B.	" 'And this old savage' etc., (short line).
14.	"	E.	"	"	59B.	" 'There was between them' etc., (short line).
15.	"	E.	"	"	59A.	" 'There was between them' etc., (long line).

(a) The knife lines which are traced on the extreme right of print mark the oscillations of the spring pendulum.

(b) In records No. 11, No. 7, and No. 15 secondary reflections from the sclerotic which were not excluded in these instances may be detected to the right of the main record. Note also the long preliminary fixation in No. 10; the signal for beginning to read was delayed.

(c) The variation in the width of the lines of the records is due to small differences in focusing.

(d) Parallel lines made with a sharp steel point and marking the edges of the page read may be noted in nearly all the records.

(e) For further description, see the text. Each group of short vertical lines represents the fixation pauses of a given text line, the longer horizontal lines are return sweeps from the end of one line to the beginning of the next line.

mined for each passage before reading by having the subject fixate for a moment first one and then the other of two bright needles which were placed on either side of the page, even with the edges

of the lines, and somewhat above them. The advantage of such needle lines for accurate fixation has been demonstrated by earlier experiments. The appearance on the negative of these two fixations is of two short parallel lines connected by a single horizontal line of the eye sweep. The distance between them denotes, then, the length of the line which is being read *in terms of the arc of the eye's movement*, or more exactly, *its corneal reflection*.

The method of measurement was as follows: These parallel lines were extended with a very fine steel point from the top to the bottom of the negative. In order to find the location of any fixation pause, it was only necessary to measure first its distance on the plate from one of these parallel lines. Its distance from the edge of the line on the page would then be this amount multiplied by the quotient of the length of the line divided by the total distance between these parallel lines. For instance, the ratio between the length of a newspaper line and its representation on the negative was about 11 to 1. Any measurement of the negative to be put in terms of distances in the line needed simply, therefore, to be multiplied by 11. The measurements, which were actually thus made directly from the plates of the earlier records, are exact to an eighth of a millimeter. A more expeditious and workable method was employed for the larger number of records. Parallel lines of the same distance apart as the lengths of line of the pages read were first drawn out on long strips of paper. These were fastened upon a large wooden screen before a stereopticon lantern. The original photographic plates were then placed in the holder of the lantern, and the records enlarged to the size of the drawings, that is, so that the parallel lines which had been drawn on the photographic plates and which marked, as above noted, the edges of the lines of print, exactly coincided with the parallel lines on the screen. The records, while thus enlarged by the lantern, were carefully copied out in their entirety in a pencil drawing. An illustration of a small section of an enlargement of one of the records is shown on Plate I. The centers of the lines denoting the pauses of the eye were then 'brought down' on these drawings by the use of draughtsman's calipers and square, and located on a line drawn perpendicular to the parallel lines. Finally tracings of these latter lines were made on transparent paper. To determine at what places the reading pauses occur in the lines, these transparent records have but to be placed over the lines of the proper pages. The location of the fixation pauses may be studied through the transparents, or may, finally, be transferred to the printed page as is done in Section XI. The work of measurement by this method was most laborious, although not so fatiguing upon

the eye as that of direct measurement from the plate, but was perhaps justified by the greater accuracy secured. The enlargement of record, the bringing down of the drawing, and transcription to transparent paper, and finally to the page of the fixation pauses, and, in the second place, the measurement and computation of the duration of the pauses, as later described, demanded a minimum expenditure of between five and six hours time for each record. The marking of the fixation pauses on the line, save for other sources of error that will be discussed immediately, is accurate to the limits of a single small letter of a newspaper page.

About 150 records have been secured in the various experiments described below.

§ 3. *Description of the Accompanying Photographs*

Since the records are taken upon a falling plate, and the bottom of the plate is thus the first part exposed as it passes by the slit in the camera box, the readings are to be made from the bottom up. Before the first line of reading there appear on some of the plates the long vertical lines denoting the preliminary fixations of the edges of the page. The movement of the eye is, of course, from left to right. Each group of several heavy short vertical lines slanting from left to right represents, to restate for purposes of clearness what has been briefly described, fixations in the given line, and the length of these lines is directly proportional to the length of time of the fixations.

If, as stated before, the eye remained immovable during a fixation, the record should be a perfectly straight vertical line. It is clear from an examination of the plates that this is often not the case. The lines incline or bulge somewhat to the right or left (more frequently to the right), and are somewhat broken by various irregularities. Some of these are due to slight movements of the head, which could not be entirely excluded; and in a few cases to minute vibrations of the apparatus. But in by far the greater number of instances, they are due to the unsteadiness of the eye itself. These various factors can be pretty well differentiated. The presence of head movements has in some of the later experiments been detected by employing a secondary reflection from some object affixed to the head. The reflection of light from a small glass bead placed near the eye and to the right of it was first used, but the most successful method has been to have the subject read through spectacles of plain glass. A very small dot upon the glass, which in no wise interferes with the reading, and in fact can not be seen by the reader, is sufficient to cause a difference in the lumin-

osity of the reflection which the glass throws into the lens, and any movement of the head can thus be detected upon the negative. The mark should be placed in the horizontal plane described above, and a little to the right of the pupil. Although it is possible in this way to detect the presence of head movements with some considerable accuracy, the difficulty of correction was such that, in view of the fact that they do not affect the general results, no further attempt has been made to eliminate them from the measurements. The divergences from the vertical which are caused by the peculiarities of the eye itself appear to be of two kinds, first, simply unsteadiness and perhaps torsion of the eyeball caused, doubtless, by the unequal tension of the eye muscles, and secondly, a very gradual change of position. This latter, as noted by Huey, appears to be a sort of 'normal' nystagmus. If it were not for the fact that it occurs in both directions, to the left as well as to the right, it might be thought that in these experiments it was caused by the reflex effect of the source of illumination, which is to the right of the primary line of regard of the eye. It is true that the line of movement starts more often to the right than to the left, but this is more probably due to the fact that the muscular tension or 'pull' of the eye as well as the movement of attention is also from left to right. In some cases these 'shifting' movements cover as much of the line of the page as is covered by one or two short changes of fixation. Their velocity is so much slower than the usual interfixation movements that they possibly satisfy the requirements of new fixations. They show that, quite apart from the compensating movements, the eye seldom remains immovable in the same position while maintaining an objectively exact fixation. In marking these peculiar fixations in the following pages, the limits of their changing positions and the direction of movement are defined. As will be noted later, their presence and the extent of their movement is one of the marked individual differences which are found in the way different persons move their eyes in reading.

The semi-nystagmatic movement of the eye occurs in the fixations which are made at the beginning and the end of the reading in order to determine the location of the edge of the page, *and thus introduces a constant source of error in all the measurements.* Its extent varies with different individuals. The amount can be at least approximately determined by measuring the ability of the subjects to maintain a long fixation of the same object during the entire time of the usual reading. This should give the maximum error.¹

¹ On account of this error, several secondary criteria were always taken into account in determining where the line representing the edge of the

The most satisfactory explanation of the phenomenon as a whole seems to be that any one of the several retinal points lying close to the fovea will satisfy equally well the requirements of what is objectively the same fixation. This conclusion seems also to be borne out by an experiment with a series of successive fixations of the same object (a brass rod). The subject was asked to fixate accurately, look away to the side, refixate, etc. The recurring of clear double images of a similar rod placed between the one fixated and the subject was taken as evidence that the same objective fixation was renewed. These 'shifting' movements which occurred as before did not interfere with the fixation or the maintenance of the double images, and thus supports the conclusion that in a single or in succeeding fixations of the same object within small limits the same retinal point or points do not need to be brought in line with the object of fixation.¹

One further peculiarity that is common in greater or less degree and frequency in all the records is the refixations or regressive movements. The eye has read on too rapidly and returns to reread some word, or the subject 'loses the sense,' and the eye must retrace its steps. This often occurs at the beginning of the lines. The eyes of most readers seldom come quite out to the edge of the line, but the first and last fixations fall somewhere within the line. This distance may be falsely estimated, the eye takes a position in its first stop too far from the edge to perceive clearly all the letters, or at least finds it more convenient to move nearer to the edge before going on with the reading of the line. This is a very common occurrence with some readers with certain lengths of line, for example subject T. This error at the beginning of the line is also

page should be drawn. If, for example, there is a 'regressive' movement (see below) after the first pause, and the second fixation is thus made to the left of the first, this can be taken as good evidence that the eye had not reached the edge of the page. One or more such refixations are to be found in nearly all passages. Corrective movements give similar indications. Then the eye makes a longer excursion in some lines than in others; these may be taken to indicate, when there is any doubt, an approach to the maximum excursion. Corrective movements in the preliminary fixations themselves also indicate attempts at closer fixation. By employing these various accessory checks and corrections, in connection with the preliminary fixations made at the beginning and end of a passage, it is believed that the locations of the edges of the page have been determined with considerable accuracy. Finally, it is to be remembered that the *relative* distance apart of any two fixations is not affected by the errors of preliminary fixation.

¹For a careful study of the inaccuracies of fixation cf. *The Yale Psychological Studies*, New Series, Vol. 1, No. 1, C. N. McAllister "Fixation of Points in the Visual Field," published since the above was written. See report of a paper on the "Fixation Pauses of the Eye during Reading," read by the writer at the Philadelphia meeting (Dec., 1904) of the American Psychological Association. *Psychological Bulletin*, Feb., 1905.

unquestionably due in part to a purely physiological cause, the inaccuracy of the motor innervation of the eye muscles. They are, in other words, partly 'corrective movements,'¹ and will be discussed in that connection later.

¹Cf. 'Retinal Local Signs,' by the writer. *Psychological Review*, XI, p. 298 ff.

CHAPTER IV

THE FIXATION PAUSES

§ 1. *The Number of Fixation Pauses and the Extent of Page Read per Fixation*

In the classical experiments of Prof. Cattell with the fall exposure chronometer it was determined that "on the average consciousness can at one time grasp four numbers, three to four letters, two words, or a sentence composed of four words."¹ This last extent of perception gives a measure of the possibilities of the range of perceptions of words, which in actual reading, as is known, is but seldom attained. In the following tables three or four cases may be noted where eight and even nine words were read in two fixations, thus covering the whole extent of a single line of a newspaper page and equaling the possible extent of word perception that has been thus determined. But ordinarily the amount read falls far short of this. Stated in millimeters, the total extent of the reader's range has been determined as 24.49 mm.,² in the cases just cited from the accompanying tables 28.2 mm. of reading matter per fixation is the amount read. On another page (see Table II) with nearly double this length (97.2 mm.) of line, four fixations was the smallest number made and eleven the largest number. Huey found, as already stated, that he made an average number of 4.8 fixations per line (M. V. 0.5). As above noted, neither doubling the distance (33-35 cm.) of the page from the eye, nor decreasing the size of type made any appreciable change in this number. The arc of the eye movement covered 78-85.8 % of the line. Change in the length of line had the greatest effect upon the number of pauses. His results are given in the following table in terms of the number of words read per fixation. According to this, lines of from 60.5 mm. to 43 mm. and of 21 mm.—in the latter case the whole passage could be read without horizontal movement—give the best results as regards the number of words that can be read at one pause. The results, however, as the author recognizes, have little significance when considered in such detail, as the effect of differences in subject matter was not considered.

¹ *Brain*, Vol. VIII, p. 304 ff.

² Huey, *American Journal of Psychology*, Vol. XI, p. 300 ff.

They seem to show, however, that roughly speaking there will be fewer pauses in the short line than in the long line.

The number of words read per fixation in lines of different lengths as measured by Huey¹ with the Delabarre eye-cup and attachment

		Length of line	Distance from eye	Words per fixation
Cosmopolitan Magazine		121 mm.	33 cm.	1.83
		121 "	33 "	1.50
Am. Journal of Psych.,	10 point	98 "	35.5 "	1.96
	8 "	98 "	" "	1.91
	10 "	98 "	33 "	1.70
	" "	60.5 "	" "	3.63
	" "	43 "	" "	2.44
	" "	37 "	35.5 "	1.94
	" "	30 "	33 "	1.58
	" "	25 "	" "	2.16
	" "	21 "	" "	2.17
	" "	21 "	35.5 "	3.33

¹ *Am. J. of Psych.*, Vol. XII, p. 293.

The experiments about to be reported were made upon eleven subjects, eight adults and three children. The adults, as noted later, were selected for the laboratory experiments by preliminary tests from a group of about thirty students. Two of the children were from the Speyer school and one from the New York City public schools.

In the following table a distribution is given of the number of fixations per line made by five different subjects in reading the same column of a newspaper, and the results of a second, third and fourth reading on the part of some of the subjects. An interval of a month elapsed between the first and second readings of subject H, and a week between the second and fifth. The second, third, and fourth were made in immediate succession. Similarly, there is a month's time between the first and the last two (second and third) readings of subject T. The readings of the other subjects were made on the same day. In Table II the number of fixation pauses in the first readings of four subjects of eight lines of a passage of the same size type and of about equal grade of subject matter, but of nearly twice the width of line (96.5 mm.), is given.

TABLE I.

Order of Readings	No. of Words Per Line			Subject H.			Subject T.			Subject S.			Subject M.		Subject F.		
	1st	2d	3d	4th	5th	1st	2d	3d	1st	2d	3d	1st	2d	1st	2d	1st	2d
Line 1	6	4	5	4	3	—	4	4	4	4	4	5	8	4	4	4	4
" 2	8	4	3	3	4	—	3	4	4	4	4	4	5	5	5	5	5
" 3	9	4	2	3	5	—	3	5	4	4	4	5-6 ²	3	6	8	8	8
" 4	8	4	4	4	5	—	4	4	4	4	4	8-9 ²	3	7	7	7	5
" 5	8	4	2	3	4	—	4	4	4	4	4	5	3	7	6	6	6
" 6	7	6	6 ¹	6 ¹	5	—	3	3	3	3	3	5-6 ²	3	6	5	3	3
" 7	5	4	4	4	4	—	4	2	4	4	4	4	3	6	5	5	5
" 8	4.5	4	4	3	4	—	4	4	3	4	4	5-7 ²	4	6	4	4	4
" 9	7.5	4	4	4	4	—	4	4	4	4	4	6	4	4	4	4	6
" 10	8	4	4	5	5	—	4	4	4	4	4		4	4	4	4	6
" 11	6	5	4	4	3	—	4	4	4	4	4		4	4	4	4	4
" 12	9	5	3	4	4	—	3	4	4	4	4		4	4	4	4	4
" 13	8	4	3	5	4	—	3	4	3	3	4		4	4	4	4	4
" 14	6.5	4	3	4	4	—	3	4	3	3	4		4	4	4	4	4
" 15	8	4	3	3	3	—	4	4	3	4	4		4	4	4	4	4
" 16	8.5	2	3	3	3	—	4	4	3	4	4		4	4	4	4	4
" 17	6	4	4	3	3	—	4	4	4	4	4		4	4	4	4	4
" 18	8	4	4	4	4	—	4	4	4	4	4		4	4	4	4	4
" 19	7	4	4	4	4	—	4	4	4	3	4		4	4	4	4	4
" 20	7	4	4	3	4	—	4	4	4	3	4		4	4	4	4	4
" 21	6	4	4	3	3	—	4	4	4	3	4		4	4	4	4	4
" 22	8	4	3	3	3	—	3	3	3	3	3		4	4	4	4	4
" 23	6	5	3	3	3	—	5	3	3	3	3		4	4	4	4	4
" 24	6	4	4	4	4	—	4	4	4	3	5		4	4	4	4	4
A. D.		.9	.5	.7	.4		.4	.5	.4	.4	.9	1.2	.5	1.1	1.2	1.0	1.0
Av.	7.1	5.4	3.9	3.4	4.0		3.8	3.7	3.8	5.3-5.6	5.5-6.0	3.4	7.1	6.1	5.1	4.76	A. D. = 1.35
Number words per fixation.		1.2	1.9	2.1	2.0		1.9	1.9	1.9	1.4-1.3	1.3-1.2	2.1	1.0	1.1	1.4	1.64	A. D. = .37

¹ Lines 6 and 7 were read together by subject H in 6 fixations.
² In some cases it is not possible to count accurately the exact number of pauses, for reasons stated in the text.

TABLE II

The number of fixation pauses and the average number of words per fixation in a long line (length of line 96.5 mm.). First readings of four subjects

Lines	No. of w.	T	H	S	F
1	12	7	5	8	10
2	12	7	6	9	9
3	11	9	5	8	10
4	13	8	5	7	8
5	10.5	7	5	(7)-8	10
6	10.5	10	4	8	
7	10.5	7	5	8	
8	11.5	6	5	8	
Total					
Av.	11.3	7.5	5	8	9.4
A.D.		1	.25	.25	.7
No. of w. per fix'n.		1.5	2.3	1.4	1.09

The average number of pauses per line in fourteen readings by five subjects of the same newspaper column is 4.76 (A. D. 1.35) fixations per line, or an average of 1.64 words per fixation (A. D. .37). This latter is a somewhat larger average than will hold in general, because a larger weight is given in the latter to the readings of the more rapid readers, and the repeated readings are included (see below). The averages of the successive readings considered separately are given in Table III. They vary from 3 to 7.1 pauses per line, or an average of 1.9 to 1.0 words per fixation. All subjects read, as stated, the same pages. The individual differences are large in view of the comparatively simple and commonplace character of the subject matter.

TABLE III

The average number of pauses (of Table I) distributed by readings and subjects.

Subjects	1st R. ¹		2d R.		3d R.		4th R.		5th R.	
	No. of Pauses	A. D.	No. of Pauses	A. D.	No. of Pauses	A. D.	No. of Pauses	A. D.	No. of Pauses	A. D.
T	3.8	.6	3.7	.6	3.8	1.1	3.6	1.2	2	.85
H	5.4	.85	3.9	1.5	3.4	1.5	2.1	2	4	1.7
S	5.3-	.7	5.5-	1.3-	5.6	1.2				
F	5.6		5.1	1.0	1.4					
M	7.1	1.1	6.1	1.2	1.1					

¹R—Reading

The average of five subjects in their first reading (Table I and Table III) is 5.3 fixations per line or 1.3 words per fixation. The average number of pauses made in a line of nearly double this length is (cf. Table II) 7.45, and the average number of words per fixation 1.6. In this case, therefore, more words are read per fixation in the longer line. The variation among different individuals shows, however, that these averages as the results quoted above of Huey have little significance by themselves. Subject H read more words per fixation in the longer line and subject T fewer. The question regarding the advantages and disadvantages of the short and long line is one that can be properly discussed only in connection with the other factors of individual apperceptive and perhaps motor differences which have not yet been sufficiently analyzed. The above comparison is at least sufficient to show that the problem is more than one of the number of words that can be perceived, or the number of movements made, and to call into question the conclusions of Javal, Huey and others that more words are read per fixation in the short line than in the long. The problem of the length of text-line is made the subject of a succeeding section.

Confining attention to the larger individual differences in the number of pauses (Table I), these differences are at least roughly correlated with the rate of reading, the rapid readers making fewer fixations. As (except in first reading of H) the rate of fall of the plate is nearly the same for all subjects, these differences in the speed of reading can be approximately estimated from a comparison of the number of lines read in each case (see Table I). An examination of the above table also shows that, while there is a tendency (compare subjects H and M) for a second, third or more readings of the same passage to decrease somewhat the number of pauses, the effect is very variable. Subject T, for instance, reads on the average about the same number of words per fixation each time. When, however, a large number of readings is made in immediate succession, there is a decided decrease in the number (and length) of the pauses. In general the effect of repeated readings is to give greater preciseness and accuracy of movement. In the first and second readings it is in the case of some subjects very difficult to decide at times how many pauses have been made, because the movements and pauses of the eye are run together by the above noted unsteadiness of the eye during fixation. After the passage has been read several times the alternation of fixation and movement becomes very regular and clearly defined. It would seem that the tension in which the eye muscles must continually be, when about to react to the more or less indefinite word stimuli on

the periphery, is much relaxed after the successive readings have made the eye familiar with the peripheral stimulation. In Table IV the first and fifteenth readings of the same passage by subject S are compared as regards the number of pauses. The passage was learned by heart before the fifteenth reading was reached, and the number of fixations represent, then, the minimum needed to bring the passage into view, or possibly simply to 'keep time' with the visual auditori-motor processes of repetition.

TABLE IV

Comparison of the number of fixation pauses in the first and fifteenth readings of the same page

Line	SUBJECT S							Av. A. D.	Av. no. of w.	
	1	2	3	4	5	6	7			
1st R.	5	5	5-6	8-9	4	5	5	5.4	.9	1.3
15th R.	4	3	4	3	4	3	3	3.4	.5	2.1

As has just been noted, there is a wide difference in the form of the eye movements between individuals. This can be best seen from a comparison of the negatives themselves (see Plate II). The differences can not be shown simply by the comparative number or duration of their fixation pauses and connecting movements. The movements of subject T are not only rapid, and the average fixations short, but they are in comparison with subject H, also a fast reader,¹ singularly precise. The fixations also are exact, and the eye comes to a distinct stop, and between each pause there is a clearly defined horizontal movement. The case is quite different with subjects H and S. It is often difficult to tell where the movement ends and the fixation begins; during the fixation the eye is seldom at rest, but is moving gradually backwards and forwards. A change of position is thus gained which is often equal to that of one or two of the usual connecting movements, and may well aid in recognition. Two or more fixations often approximate to what is introspectively thought to be the form of movements of the eye, i. e., a gradual continuous change of the positions of the eye along the whole line. These individual peculiarities are not necessarily correlated with differences in the rate of reading. The movements and fixations of subject F are quite as precise as those of subject T. Subjects S, M, and D take rather middle ground

¹ Subject T was found to be the fastest reader by several different tests in a group of 30 or more persons, and subject H stands near the top of the group in rate of reading. The differences of the first and last of the group in the several tests were as one to three. Subjects S and F stand very near the end of the group and in the order named.

between the extremes. The accompanying photographs and the charts of fixations, which follow later, represent these differences better.

§ 2. *Motor Habits*

An examination of the distribution of the fixation pauses in Table I shows a tendency to the formation of 'short-lived' motor habits. For example, in the last part of the third reading of H there is a series of five lines which were read with three fixation pauses each, and this is preceded by a group of four lines of four fixations each. Judging from a comparison of earlier and later readings of the same lines this is a purely artificial arrangement of movements which the eye holds to quite arbitrarily. We shall recur to this fact again later in discussing the causes which condition the positions of fixations in the line. A similar tendency is to be noted in all the readings of subject T; in his case series of fours predominate, broken generally by a short series of threes, and an occasional fixation of five. While such a rhythmical grouping of movements is perhaps less often secured at the very beginning of a passage, and upon its first reading, it seems almost a matter of chance whether this is the case or not. For example, the first reading of subject H shows comparatively little tendency to uniformity, whereas in the second reading, more than a month later, the reading is performed almost wholly *and from the start* in groups of four fixations per line. The initial series is broken by the infrequent case of the reading of two lines by one horizontal movement, in this case of six fixations.¹ The very first reading of another newspaper column (not given in the tables) by this subject shows a parallel case of motor habit formed from the first line. After such a rhythmical series is well under way, it would seem reasonable to expect that there must be some clearly marked change in the character or difficulty of the succeeding lines before the motor habit is altered or broken. If, in short, the difficulties of word recognition, the sequence of words and thought and other such apperceptive conditions remain similar, there would appear to be no reason why the motor habit should not persist. An examination of the table is sufficient to show, however, that these changes *may* go on quite apart from any relation to the nature of the subject matter. This is best shown by the fact that there is absolutely no uniformity in this respect between the different subjects or the successive readings by the same sub-

¹ As the apparatus records only by chance and most imperfectly the vertical movement of the eye it is not possible to say whether or not the eye alternated between the two lines, but this is, doubtless, the case.

ject. In the third reading of T, to cite one instance, the thirteenth line is the last of a group of five lines that are read in four fixations. In the next reading, which immediately followed, although there is a similar series of five lines with four fixations preceding and a group of four lines of four fixations each following, this thirteenth line is now read with three fixations. There is no apparent reason why this long rhythmical series should have been broken in the second reading and not in the first. Because of the instability or lack of regularity in these rhythmical series, I have named them for convenience of reference the 'short lived' motor habits of the eye in reading. Although the number of movements and fixations remains the same in these motor series, it should, however, be noted that there is a wide difference in the relative distances apart of the fixations within such groups. An addition or subtraction of one fixation may not, therefore, alter the general character of the movement, as it would, were the interfixation movements always of the same length.

The ease of the formation of motor habits seems to be one of the characteristics of rapid readers as contrasted with slower readers. T and H are about twice as rapid readers as S, and nearly three times as fast as F. The long motor series are found only in the reading of the first two (T and H). The larger number of lines read by them gives some advantage to the first readers, but even in the fifteenth reading of a passage by S there was not as marked a tendency to uniformity of innervation as in either of the first named subjects in their first readings. This fact is further illustrated in the case of other subjects, and will be referred to again.

§ 3. *Refixations*

Other factors which affect the process of perception are the 'regressive' and 'corrective' movements of the eye. For simplicity of statement a somewhat arbitrary distinction will be made between these two types of movement. A 'regressive' movement is caused by faulty perception or insufficient recognition and is always made to the *left*. It occurs most frequently in the return sweep of the eye from the end of the previous line. The eye for some reason stops too far short of the edge of the line, and it is necessary to make a supplementary movement towards the edge. Similarly within the line the eye may have been carried on too far for ease of recognition, and a short movement is made in the opposite direction. The 'corrective' movements,¹ on the other hand,

¹ Compare *The Psychological Review*, July-Sept., 1904, "Retinal Local Signs," where these corrective movements are described by the writer.

are real inaccuracies in the motor innervation or functioning of the eye muscles. They may occur in either direction. When they occur to the *left*, they are not easily distinguishable from the 'regressive' movements. For example, the real reason why the eye in returning from the end of one line to the beginning of the next falls short may be either an error of perception, i. e., the working span; so to speak, of perception or assimilation has been overestimated, or it may simply be an inaccuracy of muscular movement, i. e., an underestimation of linear magnitude. Some differentiation between the two movements is possible. The corrective movements as determined in the article referred to above¹ are generally of less extent and the intervals of pause before the corrections are made are, also, very much shorter. But, again, these movements may be further confused with the unsteadiness of the eye in fixation. When, however, there is an overestimation of the length of line, it is generally to be considered as due to inaccuracy of movement. The eye has been carried beyond the edge of the line, and a short, quick movement back is made. These cases can be differentiated with certainty. But it is doubtless true that a corrective movement due to overestimation occurs just as often within the line. As it would, however, simply 'correct' the first fixation in the line, it is, then, as stated, not distinguishable from the unsteadiness which accompanies fixation in general, if, indeed, it is not the explanation of a part of this unsteadiness. Because of these complications, in taking account of these 'refixations,' only those which are made to the left have been recorded.² It has, however, seemed advisable to distinguish between those which occur at the beginning of the line, and those which are found elsewhere within the line. They have, therefore, been divided in the tables on this basis into two classes; first, those which are supplementary to the return sweep of the eye, marked *Sp*. They include both the positive³ corrective movements and the initial regressive movements. Those marked *Rg* are the regressive movements within the line. The term 'refixation' is used to cover all cases. In Table V the

¹ *Psychological Review*, XI, p. 298 ff.

² The refixations which are made for perceptive purposes are naturally only regressive (i. e., to the left). When a movement and pause occurs to the right it marks, of course, a new fixation.

³ In the article just referred to, these corrective movements were designated as positive, which added to the primary movement in its original direction, i. e., the eye had fallen short of the mark, and another movement in the same direction was necessary. Those movements in which an overestimation occurred, causing a return movement in the opposite direction to the initial movement were, on the other hand, designated 'negative.' For the reasons stated above, account is made only of the 'positive' corrections.

number of refixations is arranged according to the lengths of lines in which they occurred. Comparison is made of three different pages.

TABLE V

The number of refixations in lines of different lengths

		Page I Length of line 107 mm.			Page II Length of line 96.5 mm.			Page III Length of line 56.5 mm.		
		No. of lines	No. of Sp	No. of Rg	No. of lines	No. of Sp	No. of Rg	No. of lines	No. of Sp	No. of Rg
A										
A. Subject	T	16	11	0	11	7	0	74	5	0
"	H	65	14	3	6	1	0	106	9	0
"	S	5	4	0	13	3	4	60	8	3

Percentage of lines having refixations

B		Sp.	Rg.	Sp.	Rg.	Sp.	Rg.
B. Subject	T	69%	0	63.6%	0	18%	0
"	H	21.6%	4.5%	16.6%	0	18%	0
"	S	80%	0	23%	30.7%	11.4%	4%

Distribution of refixations in percentages of the whole number according to the order of lines irrespective of their lengths

C		10-20							
1st	2nd	3rd	4th	5th	6th	7th	8th	9th	all other Ls.
24.07%	7.4%	5.5%	7.4%	9.2%	5.5%	12.9%	7.4%	5.5%	14.8%

¹ 'No. of lines' refers to the total number of lines read by each subject.

Under *A* (Table V) the number of lines read and the number of supplementary and regressive movements made are arranged according to subjects T, H and S. Under *B*, the same facts are restated in the percentage of lines in which these movements occur; under *C* the refixations, etc., are redistributed accordingly as they occur in the first, second, third, or fourth lines, etc. The results in *C* are stated in percentages of the whole number of cases (54). As can be seen (*C*), the largest number are found in the first line of the different passages read. This may possibly be due to some peculiarity of the experiment. The eye before reading made in each case a movement of the same length as the line about to be read, i. e., as already described above, between the needles which were used to denote the edges of the line. But there would seem to be no particular reason why this return movement to the beginning of the first line should not be as accurate as later, and

no peculiarity was noted by the subjects. The more natural explanation is that the eye has not yet accustomed itself to the right extent of motor innervation.

My purpose in the preceding tables is first to call attention to the frequency of refixation. It is also to be noted that there are some differences between subjects in this respect and these differences are most marked in the longer lines. It appears also true that the ease and accuracy of movement and of perception, as denoted by the comparative infrequency of refixations, is greater in the shorter line. Subject T makes, however, a supplementary movement so regularly in the long line, that it must be considered his habitual reaction; that is, to a certain extent, instead of determining the length of the return sweep of the eye by the length of line being read, the return sweep proper remains relatively constant, whatever the length of line may be. It is then corrected or supplemented by another movement, if it is found necessary for perception. This gives evidence of another interesting variation of the method of performing the physiological process of reading. The inaccuracy of movement and the necessity of refixation must ordinarily, except possibly in the case of T, be a hindrance to the rapidity of perception. That they are found somewhat more frequently in the long lines may be considered one of the disadvantages of this length of line. When reading aloud, regressive movements are in some cases doubtless due to the eye returning to the word that is being pronounced. But since they are as common in silent as in oral reading, the more evident explanation is, then, that the eye has run too far ahead for the thought, or some misunderstanding has been met which calls for clearer perception of the words that are but now reaching consciousness. The refixations, especially when they occur within the line, may thus serve to indicate roughly how far the perceptive processes antedate recognition and assimilation.

There is evidence that the corrective movements, as might be expected, occur also in the vertical plane. The eye does not follow along the line with exactness,—as, for instance, Javal thought, along a line between the middle and top of the small letters. In view of the inaccuracies of movement this may be considered as literally a physical impossibility. A plate falling in the vertical plane is evidently not at all suited to a study of discrepancies of movement in that plane. The rate of movement, however, of the eye upward from the horizontal is in a few cases so rapid as to counterbalance and even exceed the rate of fall of the plate. An

upward movement of the eye is reversed on the negative, and so the movement appears in the same direction as that of the recording plate. In this way these inaccuracies in the vertical plane are occasionally detected even in these records. They are deserving of further study.

To test the hypothesis suggested above that the greater number of refixations in the first line is due to the fact that the extent of movement has not been adjusted correctly for the length of line, I arranged an experiment so that the length of the return sweep of the eye was varied several times during the reading. This was attained by simply cutting out a page of print by lines and then pasting the lines together so that the edges were indented or uneven. The exact arrangement which has been set up in the same size of type used may be found in the appendix. This distance between the lines on the original page was 2.5 mm. It has been necessary to make the plate for reproduction (cf. Pl. III) from a typewritten copy in order to write in conveniently the signs which denote the places where the eye pauses. The lines were originally all of the same length, 88 mm. The amount of indentation was 26 mm. The small size of type was used purposely to make it more difficult for the eye to decide just where the lines began. If the apparatus were capable of registering movements in the vertical plane, there is every reason to believe, as has been noted, that the inaccuracies of fixation on the vertical plane would be found perhaps as marked as those of the horizontal. This is evident from a common experience; not infrequently we find, especially when the line is long, of small type, and of little interspacing, that we have begun reading the wrong line, the eye having either skipped a line or having returned to the beginning of the line that has just been read.

The method of plotting the location of the pauses is described later. It is sufficient at present to note that in this page a single straight vertical line | denotes the place of the fixation. If the eye is unsteady or moves somewhat in one direction or the other, a horizontal line connected with this and drawn under the letters denotes the direction and extent of the movement; i. e., the sign $_$ = fixation and very slow movement to the right, $_$ = movement to the left. The fixations are numbered in the order in which they are made. These numbers are put below the signs. The durations of the pauses in sigma are placed above as index numbers to the signs. These movements during fixation are dif-



LIBRARY
OF THE
UNIVERSITY
OF
CALIFORNIA

PLATE III

(REFIXATIONS)

The³⁹² boatswain¹⁸⁰ was⁷⁹ killed⁴³⁶ upon the spot; the next man⁴⁶⁴ was shot in the
 _____ body, and fell just by him though he²⁴¹ did not die until²¹¹ an hour or two¹⁵⁵ after⁹⁵¹ _____

⁴⁰⁸ and the third³⁹¹ ran for it. At the¹⁶⁰ noise of the fire, I²⁶² immediately²¹¹ advanced³

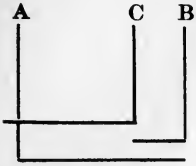
²⁹⁰ _____ with my whole²²⁴ army, which⁴⁰³ was now²⁶⁰ eight miles³⁰⁴, viz. myself, general—¹³⁶

_____ Friday, my³⁶⁷ lieutenant²⁷³ general, the captain²³⁵ and his two^{a c 357 b} men⁵⁶ and _____³⁴⁵

the three^{a 372 b} prisoners of war, whom⁴⁹⁵ he²⁷⁰ had trusted²⁰¹ with⁴ arms. We⁴¹⁶ came _____

^{b a 372} upon¹⁹⁶ them indeed²⁷⁹ in the dark, so that^{a b 377} they²⁴⁵ could^{oo} not see⁴ our number;

ferentiated, as above noted, from the interfixation movements proper by less velocity. Such a combination of signs as appears at the beginning of the fifth line somewhat incompletely describes the unsteadiness and the several directions of movements during fixation. What took place was as follows: The eye, after a pause at *A*, makes a gradual forward movement to *B*, pauses and moves back rather rapidly to *C*, and from *C* moves back very gradually toward the edge of the line, and a little beyond *A*.



The results are most interesting. The eye fell too far short in the first line (Fixation No. 1) necessitating a re-fixation nearer the beginning of the line. Just the opposite 'mistake' was made in the second line, that is, the extent of movement was overestimated.

The following explanation of this error seems most in accord with the facts. The length of, at least, the first return sweep is estimated largely in indirect vision, when the eye is focused near the end of the previous line. The peripheral estimation in this case was vertically inexact to the extent that the edge of the second line was overlooked, and the edge of the third line mistaken for it. The error was not perceived until the first fixation was made in or above the beginning of the third line. The movement of the attention back towards the beginning of the second line is shown by the direction of the gradual movement during the fixation. From that position, however, a fairly clear peripheral perception of the beginning of the second line could be secured, and the second fixation is, therefore, made well within that line. That there is still some uncertainty is shown by the backward movement of the third fixation.

The error made at the beginning of the second line is corrected in the third line, although there is also evidence here of overestimation in the comparatively unusual proximity of the first fixation to the beginning of the line. The more accurate estimation of the correct arc of movement may be due in part to another factor, namely, the resident muscular sensations of the extent of the angular displacement of the eye along the second line. The accuracy of these sensations is not, however, believed to be as great as when the extent of movement is determined by the retinal local signs. The accuracy of the former is, as will be further noted, greatly increased by repetition of the same arc of movement.

The angular displacement of the line of regard from the end of the second line to the beginning of the third line was exception-

ally large, corresponding to about 115 mm. on the page. It is the present thesis that this overestimation was due to two factors, the tendency to repeat the same extent of movement as was made in the previous return movement, and, secondly, the relative inaccuracy of peripheral discrimination. When local discrimination is more exact, i. e., when the point of stimulation lies nearer the fovea, it serves as a check on the tendency of the motor impulse to repeat itself. The fifth and sixth lines are an instance in point. The beginning of these lines falls well within the field of accurate local discrimination, and, although there is considerable unsteadiness of fixation, there is no inaccuracy of the motor impulse such as was found in the fourth and again in the seventh line. The seventh fixation of the fifth line is also of interest as further showing the difficulty and uncertainty of movement produced by this arrangement of lines. The eye moves beyond the edge of the line, necessitating a correction by the eighth fixation. To repeat, is this peculiar phenomenon as well as the unsteadiness of the fixations at the beginning of the fifth and sixth lines due to a sort of blind force of motor innervation? The peculiar unsteadiness of fixation just noted, and the large error of estimation now to be noted in the first fixation of the seventh line show that the force of the resident sensations of the previous movement is from long habit and practice very potent in determining the extent of the succeeding movement. The exact point of fixation depends on the accuracy of local discrimination in indirect vision, i. e., on the retinal local signs. If the latter are accurate, as was the case in line five, because the edge of the line could be clearly seen when the eye was fixating the last word of line four, the next fixation will be exact, despite the tendency of motor innervation to be governed in extent of movement by the previous movement. The regressive movements in the first and second fixations of both lines give evidence of this tendency. If, on the other hand, the point that is about to be fixated lies so far upon the periphery that the accuracy of local discrimination is decreased, the motor impulse has full sway, and is subject to correction only after it has completed itself. This seems to be the case in line seven. As in the case of the second and third lines, and particularly the fourth line, the angular distance from the end of line six to the beginning of line seven was too great to admit of accuracy in local discrimination, if made, when the eye was fixating the former point. *The arc of movement of the previous line is repeated to a minute*, with the result that the first fixation fell far short of the edge of the line and a supplementary movement of large extent was made necessary. The case is nearly an exact reversal of the overestimations

made in the second, third and fourth lines. There was the same inaccuracy of local discrimination due to extreme peripheral vision. But whereas the repetition of the same arc of movement in lines 5 and 6 gave opportunity for acquiring a short motor tendency or habit for a given amount of angular displacement, the lack of uniformity in the extent of movement in lines 1, 2, 3 and 4, due to the inaccuracies of perception in both the vertical and horizontal planes caused a wider extent of overestimation. *In a word, the overestimation and the underestimation are both explained by the inaccuracy of local discriminations on the periphery; the differences in amount were due to the acquirement in one case of a tendency to a fixed extent of motor innervation, and to the lack of it in the other case.*

The correct extent of movement is acquired in the first or at most second trial, and the succeeding movement follows automatically and with greater accuracy. The motor habit once acquired tends to persist even when the angular extent of movement is altered, as in the present experiment. The error of fixation is, therefore, in this case due more to the persistence of the motor impulse than to inaccuracy of perception. An inaccuracy due to the latter cause, i. e., an error of local discrimination of peripheral vision, would very infrequently, especially in movement of this small angular displacement, equal in extent the distance found between the first and second fixations of the seventh line. The average errors determined in the experiments above referred to¹ were for one subject 1° 48' and the other subject 2° 59' 24". The extent of the inaccuracy of vertical estimation assumed as the explanation of the error made in the second line is, on the other hand, quite within these limits.

The conclusion, therefore, seems warranted by the results of the experiment that the larger number of refixations at the beginning of a passage is due to the fact that the motor impulse is in the process of adjustment. The experiment also justifies a second conclusion, namely, that normally the extents of angular displacement of the eye tend to become uniform, due to the formation of motor habits of reaction. The errors of fixation are due in part to the subversion of these motor tendencies.

The greater preponderance, therefore, of refixations in the first lines of a passage, to recur to the original question, is due to the inaccuracy of local discrimination unsupplemented by any resident muscular sensations of the correct extent of movement. Since the length of lines remained the same in the above pages, the accuracy

¹ Cf. *Psychological Review*, XI, p. 301.

of fixation in the succeeding lines was much abetted by the rapid acquirement of a short motor habit of the given extent of movement.

The reason why there are more refixations in long lines is not due primarily to motor difficulties, but to inaccuracy of peripheral discrimination. The reason why there are fewer refixations and why greater accuracy of movement is attained in the short line is that movement is subject to the correction of accurate vision and the guidance of motor habits.

The experiment has demonstrated that the difficulties of accurate fixation may be increased even for the practised adult reader by necessitating too frequent change of the arc of movement. Uniformity in the length of line is doubtless, therefore, even more a desideratum for beginners in reading. An examination of school primers and readers will, however, convince anyone that the mistake of employing many different lengths of line is unfortunately more commonly made in these books than in perhaps any other class of books. The fault arises in part from printing each sentence as a single paragraph, necessitating many incomplete lines; but it is chiefly due to the insertion of pictures and drawings in the margins of the pages. If the pictures are highly colored this in itself, if we may give any weight to the experiments which have been made concerning the reflex effect of peripheral color stimuli upon the accuracy of fixation,¹ may be a hindrance to accuracy in the reading movements. It is, of course, recognized that such objections as the latter may be entirely outweighed by the advantages of securing and holding by this indirect means the interest and attention of the pupil, etc. But the objectionable features may be minimized. There is, however, no such evident justification for the large differences in the lengths of line. As will be made clear when the question is taken up in a later section, the acquirement of a uniform motor habit and a certain rhythmical sequence of movements and fixations depends entirely on the length of line, almost to the exclusion of the effect of differences in the form of sentence and of subject matter.

As an illustration of the differences that may be found on almost any page, I have given below the measurements of the first twenty lines of a second reader in common use.

¹ Cf. for example R. MacDougall. *American Journal of Physiology*, 1903, pp. 122-130.

Measurements in mm. of the lengths of line in a 'second reader'

<u>Line</u>	<u>mm.</u>	<u>Line</u>	<u>mm.</u>
1	57.5	11	61
2	49.5	12	96
3	12	13	84
4	35.5	14	85
5	41	15	97
6	41	16	87
7	41	17	67
8	35	18	81
9	83.5	19	71
10	96.5	20	95

The length of line of the book in question is 101 mm.; that of the page under experiment was 88 mm. The indentations were 26 mm.; in the reader there are differences of 40 mm. and more. There is little justification for the diversity of motor innervation which is thus produced.¹ The only advantage is in the size of type of the reader, which was 2 mm. in height (of small n), but, as noted later, I have found many much longer lines in these readers of but 1.5 mm. in height.

As an illustration of the extent to which this total disregard of uniformity in line arrangement has been carried, a couple of pages from first and second readers in common use are here reproduced with the omission of the pictures on the margins and in the body of the text.

An examination of the printed charts and diagrams that are used in the teaching of reading and the other school subjects will also reveal a large number of the more purely physiological difficulties, needlessly and gratuitously put in the way of the beginner.

¹ A small indentation of a few millimeters, for example of every other line, but not of sufficient extent to affect the uniformity of the horizontal movements, or even the length of line itself, may be of a distinct advantage in eliminating motor inaccuracies in the vertical plane. The indentation would help to differentiate the lines, and prevent their confusion. This suggestion was made by Professor Cattell.

PAGES ILLUSTRATING POOR LINE ARRANGEMENT.

On his way back he finds the horse
 looking over the fence, as if he
 were watching to see that the work
 is properly done. Then the gardener

thinks of the thirsty flowers and gets
 his watering pot to sprinkle them.

<p>A tree den is the home who likes to nip grow on it. and here is an are some ripe</p>	<p>in one end of the gar- of this little bird, the pears that Here is a pear, apple, and here strawberries, too.</p>
--	---

The birds find them all; for the
 gardener grows them for
 his children. The children eat
 them, and think they are very good.

The gardener has also many pretty
 flowers in his garden: red roses and violets.

PAGES ILLUSTRATING POOR LINE ARRANGEMENT

NCE upon a time a donkey
heard a grasshopper chirp-
ing in the grass.

He was very much
pleased with the beautiful song.

“Ah!” he said to himself,
“if I could sing like that, how happy
I should be!”

So he bowed low to the grasshopper,
and said, “Kind friend, what food do you
eat to make your voice so sweet?”

“I drink the evening dew,” replied the
grasshopper.

The foolish donkey tried to live on the
same food, and died of hunger.

An eagle flying through the air was
wounded by an arrow from the bow of
a hunter.

The king of birds fell to the ground,
for the arrow had entered his heart.

As the eagle looked at the arrow, he saw that
its shaft was tipped with his own feathers.

“How hard is my fate!” he moaned, “I
helped to wing the arrow which kills me.”

CHAPTER V

IS THERE PERCEPTION DURING EYE MOVEMENT?

Preliminary to the further study of the significance of the fixation pauses, it is necessary to review in greater detail the evidence (see above) upon which the conclusion was reached that the eye does not see during the movements in reading. The answer is of first importance to the theory of the fixation pauses. As already noted, Erdmann and Dodge computed that from $\frac{1}{3}$ to $\frac{2}{4}$ of the reading is spent in fixation, and, on the basis of measurements by Dodge of the angular velocity of eye movements, argued that, if the rate of movement found held good for reading, it did not admit of perception during the interval.

Dodge found by means of a modification of the Helmholtz-Lamansky method of after images the average length of time for a movement through five degrees to be .015", and through 10 degrees .02". Estimating that the velocity of the short interfixation movements must be at least as much as .02", the problem was to determine whether a fusion of the letters—which would preclude their recognition—does not result at that rate. About 12 or 13 letters represent in the line the average extent of the movement of the eye between two pauses. Counting the separate parts of the letters and the intervening spaces, the appearance represents an alternation of about 50 black and white stripes. The white spaces are about three times as broad as the black lines. This would make the length of stimulation of each of the black lines (if the velocity of movement for the whole arc is .02"), .0002", and of the white spaces .0006". But according to the experiments of Plateau fusion of the black and white sectors of the color wheel occurs when the interval of stimulation of the single sector is as long as .008". Baxt also determined by another method that the time of stimulation in order to allow recognition of a single letter must be .0303" and for recognition of three letters .0533". While the conditions in reading are not exactly the same as the above experimental conditions, the very much smaller time of stimulation in the former case seemed to the writers to warrant the conclusion that fusion occurs during the movements of the eye, and that, therefore, the recognition of words occurs only during the fixation pauses.

The question was also put to an experimental test by passing lines of print rapidly from left to right before the eye at the same rate which the eye must supposedly pass over the letters in reading, and it was found that fusion of the letters did actually result. The importance of the conclusion, of course, lies in this,—that it is only in the interval of rest or pause that visual perception is possible.

The conclusion carries with it two or three assumptions which may be called in question and at least need verification; first, that the angular velocity of the short movements of the change of fixation within the line is as rapid as the voluntary sweeps of the eye; whereas it is possible that the speed of the return movements of the eye to the right may be so much more rapid than that of the interfixation movements proper, that perception may be excluded during the former but not during the latter. In the second place, the possibility of considerable variations in the rate of the interfixation movements themselves was not recognized. It is assumed that the pause is a full stop of the eye and that the remaining time must be taken up wholly by the change from one of these positions of rest to the next or succeeding pause. But it is evident from an examination of the accompanying records that there are intermediary stages between the distinct breaks or pauses in the movement and the movements proper.

These facts or possibilities make an actual measurement of the interfixation movements themselves desirable. This has already been done to a certain extent in two more recent investigations.¹ The measurements of Huey are subject to the criticism that the extra weight of the eye-cup and pointer may have retarded the movements of the eye. He found the velocity of movements to the right to be on an average 43.9σ for angular movements averaging 3° 36'. The value of the more accurate measurement of Dodge and Cline is unfortunately somewhat lessened by the fact that only the average of movements varying from 2°-7° are given. That is, it may be of some importance to know what the velocity of movement is in each case and especially when the movement is of small extent.

Their results are as follows:

¹ Huey op. cit., Vol. XI. Dodge and Cline, *The Angle Velocity of Eye Movement*. *Psychological Review*, Vol. VIII, pp. 145-157.

Dodge and Cline on the velocity of the eye in reading

Movements towards the right						Movements towards the left.				
Sub- jects	No.	M.	M. V.	Max.	Min.	No.	M.	M. V.	Max.	Min.
A	12	23.7	3.9	36.5	17.5	5	45.6	3.7	50.1	40.9
B	18	21.9	3.9	29.2	15	5	40.1	2.9	43.8	35.0
C	10	23.2	6.1	32.8	14.2	4	37.1	1.9	39	33.4
General Average						40.9				

The average time of the three subjects for the interfixation movements of from 2° - 7° is 22.9σ and for the return movements to the left of 12° - 14° 40.7σ . It is noted that this result of the movements to the right approximates closely the original assumption of Erdmann and Dodge regarding the rate of movement ($.02''$). Compared with the angular velocity of movements made in response to peripheral stimulus, the movements to the right fall below the general average of eye movements of 5° (34.5σ M. V. 1.5), and those to the left that of the general average of eye movements between 10° and 15° , i. e., between 41.8σ , M. V. 1.4, and 46.7σ , M. V. 4.5.

The conclusion drawn from this fact is that "the character of the eye movements in reading is not materially different, qualitatively or quantitatively, from the eye movements which are made in response to peripheral stimuli as the eye looks back and forth between two fixation points."

The same writer has since in another study¹ after a most careful series of experiments and many preliminary failures succeeded in demonstrating experimentally that fusion does take place in these latter movements. The normal fusions of colored fields were secured and "a part of a page of print exposed only during movement gave a perfect though shadowy series of gray bands on a lighter background, in which individual letters or words were absolutely unrecognizable."² Although the arc of movement employed in these experiments was necessarily large (50°) and the velocity of movement was, therefore, proportionately great, there can be but little question that the results are directly applicable to the movements in reading in general. Since, however, the rate of movement has not been determined for any large number of interfixation movements, it seems desirable that this be done, especially as these latter movements differ from the longer

¹ Dodge, "Visual Perception During Eye Movement." *Psychological Review*, Vol. VII, pp. 454-465.

² For further experiments and discussion concerning the nature and cause of fusion, see the article just quoted, pp. 464-465 in particular, and Holt, *Psychological Review*, Monograph Supplements, Vol. IV; and Dodge, *Psychological Bulletin* for Aug. 15, 1905.

movements made in response to peripheral stimulation in one way at least which may have some significance; they are of much greater variability in velocity. In the course of this investigation I have determined in a very large number of cases the exact letters and words that are passed over by any given interfixation movement, and at the same time measured the rate of movement. With this data at hand I have repeated the calculations of Erdmann and Dodge, in order to offer additional evidence for the operation of fusion in the short and comparatively slow interfixation movements.

Although the rate of fall of the plate adopted for reasons already assigned is not as well suited as a more rapid fall would have been for careful measurement of the interfixation movements, since the eye's movement is enlarged as noted about four times by the camera, and the record may then be enlarged upwards of twenty times without inconvenience, giving a total enlargement of from 75 to 100 or more times, sufficient accuracy can be attained from the records as made. In order to secure as great accuracy as possible, however, only the best and clearest of the interfixation movements on a given plate were selected for measurement. This doubtless gives a greater preponderance to the slower movements, as they naturally make the longer and clearer record, but this is an advantage, because the purpose in mind is not to determine the average rapidity of movement, but simply to test the validity of the supposition. And it is in the slow movements, if at all, that the hypothesis is open to question.

These measurements (as well as those of Dodge) are always subject to one error due to the limitations of the method of registration. When the movement of the eye does not follow the exact horizontal level, but moves upwards or downwards at the same time, the extent of registration is diminished in the first case and increased in the second case due to the fact that the plate is falling during these changes in the vertical plane. Head movements in the vertical plane would cause a similar difficulty and error. That this does occur can be detected in some instances, but the amount of error can not be determined. But this error is as apt to occur in one direction as in the other; that is, is as apt to increase the duration of movement as to diminish it. We have, therefore, selected only the slowest movements. If the rate of movement in these is sufficient to cause fusion, it must occur in the more rapid movements.

In Table VI the velocity of the first ten return movements to the left in reading a newspaper column is given. Width of line 56.5 mm., app. $12^{\circ} 30'$. The extents of movement are stated in

terms of distance on the line, and in degrees of the angular excursion of the eye. The results agree with those of Dodge just quoted.

TABLE VI

Velocity of movements

RETURN MOVEMENTS TO THE LEFT

	σ	Extent of Line Covered		Degrees of Mt.
1-2	44	45.5 mm	=	10.0
2-3	54	37.25	=	8.1
3-4	35	51.5	=	11.3
4-5	50	49.5	=	10.9
5-6	42	40	=	8.8
6-7	38	45.5	=	8.0
7-8	38	49	=	10.2
8-9	41	35.5	=	7.8
9-10	48	57	=	12.5
10-11	25	63.5	=	14.0
11-12	30	47.5	=	10.4
12-13	35	46	=	10.1
13-14	38	24	=	5.2
14-15	46	45	=	9.9
15-26	35	47	=	10.3
	Av. = 39.0 σ	Av. = 45.7mm.		Av. = 9.8°

TABLE VII

Showing the duration and number of letters and intervening spaces covered by sixteen interfixation movements

	No. of (a) Letters	(b) Spaces	Time of Movement in σ
1	14	38	31
2	10	20	22
3	9	21	19
4	12	33	16
5	8	20	16
6	5	11	22
7	13	28	16
8	7	15	32
9	6	15	25
10	4	11	25
11	11	22	30
12	6	14	22
13	5	11	19
14	8	22	22
15	7	13	19
16	4	10	15

Taking the totals and counting each letter as composed of two black lines and counting the intervening spaces as equal in width to three black lines, we have $(2 \times 129 + 3 \times 304 =)$ 1170 black and white sectors, which must be passed over by the eye in 351σ , or the time of stimulation of one black sector is .0003'. The result is very close to the first computations of Erdmann and Dodge (.0002'). The duration of stimulation is well below the threshold necessary for producing a distinct visual impression. It is true that if one selects the two or three movements of least duration in the above table, the time of stimulation is just about the threshold. But even if there were opportunity for perception during the slowest movements, the habit established in the average and rapid movements of disregarding percepts during movement would doubtless carry over to the slow movements.

CHAPTER VI

THE DISTRIBUTION OF ATTENTION IN PERCEPTION

In the above computations no account has been made of the slow 'shifting' movements that are very common in the records of some subjects, noticeably H and S. They form an intermediate stage between the fixations proper and the interfixation movements. The distance traversed is often equal to that read in other cases by two or more fixations and connecting movements, and, *although the eye has been in constant motion, the necessary perceptions have been made* quite as well as if the eye had made one or more abrupt pauses. Since the movement is so slow—not infrequently ten to twenty or more times slower than the usual movement between fixations—it is fair to assume that *the eye does see during these movements and that in fact they take the place of the more clearly defined fixation pauses.*

In the present study, therefore, the 'shiftings' under discussion have been grouped as fixations. The chief reason for this classification is that they are generally followed by a rapid movement of the usual velocity. The 'shifting' movement can hardly, therefore, serve the purpose of a mere change of the point of regard, and its function must be similar to that of the usual reading pause. What the differentiation is functionally between this gradual movement and exact fixation must be left largely an open question. Judging, however, from a study of the directions of various movements, it seems evident that they follow or accompany the movement of attention.

It is not believed, however, that these shifting movements necessarily denote a successive perception of the parts over which the line of regard is moving, although it may possibly mean that in some cases, and it is then the exceptional mode of reaction. The basis for this supposition is that an examination (cf. Charts of Subject H) of the words thus read offers no explanation of why these elements should be singled out for successive perception, especially since in a previous or succeeding reading the fixation is often made without shifting. It is by far more likely that the lingering of the eye over the separate letters has no effect on the simultaneity of the resulting perception. It more probably denotes a central difference in the rate of assimilation. Suppose, for ex-

ample, that, as a given foveal perception is completed, the attention changes to the matter lying on the periphery of vision. This movement of attention must precede that of the eye from purely physiological reasons. The difference in the promptness of the corresponding change in fixation may then depend on differences in the intensity and concentration of the attention upon the new peripheral sensation. In one case, because perchance of the slowness of assimilation and recognition, the attention, although already turned to the periphery, is not at first as 'intent' or alert to the sensation. In that case the muscular tension and unbalance towards the periphery which always marks the separation of attention and fixation is less acute, and the eye shifts more gradually, at least at the start. When, on the other hand, attention is immediately 'concentrated' peripherally, the muscular strain is at once too great and a rapid change of fixation follows. We can, in other words, conceive of a sort of rivalry of the peripheral perceptions to gain the center of consciousness, and this may cause a fluctuation of the attention from the fovea to periphery which the slower movement of the eye muscles can simulate only by denoting the general 'tendency' of the change of attention. When, according to this view, the peripheral stimuli at once gain the center of conscious perception, there is no hesitation in the response of the eye. This, however, it should be noted, marks a successive perception of word wholes and phrases, and gives no confirmation to a theory of a successive perception of the letters and elements of the word. If, moreover, the shifting movements were due to the latter cause, we should be at a loss to explain the usual type of motionless fixation, as will be noted further in another connection.

In this respect the hypothesis of the relation of fixation and attention is at variance with the Wundtian theory, developed by Zeitler.¹ The latter held that the perception of a given group of several words (during the short exposure of the tachistoscope) is not simultaneous but successive. The attention moves over the field of exposure from left to right, passes lightly over the unimportant parts of the words, and singles out certain more significant parts, the so-called domineering letters. These serve ordinarily as the principal basis for perception. (Domineering letters are (1) capitals, (2) letters that stand above the line as l, t, d, h, k, and especially such combinations as scht, and (3) in some instances m, w; i. e., the broader letters, although neither author is clear on this point.)

Messmer¹ proposed a modification of this theory. The attention is supposed by him to have no uniform motion but to flit back and

¹Op. cit.

forth over the words, singling out first the domineering letters and secondly the other letters.¹ Successive stages of apprehension occur only in words which include one or more domineering letters. I quote directly from Messmer's own statement of his interesting theory.

"The greater or less uniformity of general configuration (Gesamttfiguration) does not in itself stand in direct relation to 'recognizability.' It serves rather as a more or less powerful occasion or cause (Anlass) to a unitary-innervation (Gesamttinnervation). If, for example, I have seen the words *physiologisch*, *psychologisch*, *philosophisch*, *philologisch*, as often as the words *wimmern*, *übereinstimmen*, *nennen*, *weinen*, etc., I am compelled in reading the first example to read by analyzing into sections (Stücken), while the words of the second group are clear to me at a glance. Why is this? The words of the first group receive from their letters much less assistance to a 'Gesamttcharakter,' than those of the second group. One may say: the more a word possesses letters of individual geometrical form, so much the more does a unitary innervation run danger of being divided. On the other hand, the more the letters of slight individual form (with straight lines) predominate, so much the greater is the impulse to a unitary innervation."²

Since, however, "the greatest unity of total image (Gesamtbildes) and the maximum vivacity (Lebhaftigkeit) are two diametrically opposed factors," or again, since "the Gesamttinnervation and the certainty of recognition stand in inverse ratio to each other," the most fortunate cases for recognition are those in which "both these factors participate in approximately equal parts in the word-image." That is to say, words like *wimmern* are perceived immediately as wholes, with little or no effort and for that very reason are likely to be confused with a word like *weinen*. Words, on the other hand, like *physiologisch* and *psychologisch* compel on the part of attention a prior recognition of certain more prominent parts. The words are split into the elements and the separate sections successively perceived, and are thus less often confused. The best words for both certainty and rapidity of recognition are those which combine the merits of both these classes, i. e., part of letters that stand above the line and part of short letters. The examples cited of this class are 'charakteristisch' and 'wissenschaftliche.' It is not necessary here to discuss in detail

¹ I have reviewed the work of Messmer in more detail than is necessary here in the *Journal of Philosophy, Psychology and Scientific Methods*, Aug., 1905.

² Op. cit., pp. 224 ff.

this interesting analysis, but I may record a repeated observation of my own experience which I have found verified in the case of several students who make much use of the words, that there are no two words which I more often confuse, and apparently in direct proportion to the times read than the English words *psychological* and *physiological*, and a good second are the words *philosophisch* and *philologisch*. My own observation is *that these words are read wrongly repeatedly and therefore read as wholes*, and even when the context makes it clear that a mistake has been made it is only with the greatest effort that it is possible to analyze them into their parts and tell 'which is which,'—so strong is the tendency to read the words as wholes.¹

That the domineering letters as well as other peculiarities which we note in words, as their lengths and the relation of letters, are made use of as 'cues' in perception is, I think, not questioned. Moreover, it is evident that some of the subjects in the experiments of Messmer in tachistoscopic reading caught only small sections or parts of words and that others read larger sections and whole words. But I have yet to find any evidence to substantiate the two hypotheses based on these facts, viz., first, that the presence of several domineering letters and complexes lessens the chances of the perception of the words as wholes,—this point has just been discussed,—and secondly, that because some individuals perceive smaller extents of words than others (in tachistoscopic reading) the perception of the letters is composite; i. e., made by a hurried combination of the fragments of perception. To discuss this latter point, it is just as logical or illogical to adopt the alternative that, since some subjects perceive whole words and others only sections, that, therefore, the real method of the latter is analytic. That is, it might be argued they really perceive the whole word or much larger sections, but only a small section gets to consciousness with sufficient vividness. Either assumption is equally objec-

¹ There is no difference in the unity and simultaneity of perception of the two classes of words. Both are perceived at once as units, but while *nennen* and *weinen* are similar in form, the context generally saves them from confusion, whereas not infrequently any one of the words, *physiologisch*, *psychologisch*, *philosophisch* will fit for the moment into the context. The trouble comes when we have to analyze and see which is the right word. So accustomed are we to perceive words as units, that we find considerable difficulty in making this analysis. If there is a difference between these two classes of words, the difference first appears when we try to analyze; and of the two classes the latter seems the harder to analyze. The reverse ought to be the case were they ordinarily first perceived as parts, but how much of this is due to context and previous confusion and how much to the presence of domineering letters, is an open question. The difference in these two classes of letters is well worth pointing out, but I doubt if the question of their significance in perception has been correctly answered by Messmer.

tionable. The only fact which has been brought out is a difference in the span of attention among different individuals. And this no more justifies the assumption that the method of perception is synthetic in one case, than that it is analytic in the other. It justifies neither. What this fact does make plausible is that the subject who can read but small sections may have to combine them in order to obtain wholes. The subject who seizes the larger sections and whole words has them to start with and consequently has no need of synthesis; and in that case, the perception of the first subject may be accurate and exact, and that of the latter confused and liable to error. The fallacy of Messmer is in attempting to reduce to uniformity results that clearly indicate individual differences among his subjects. Evidently as far as tachistoscopic reading is concerned, the individual who reads by syllables (or sections of domineering letters), must combine them to get words, but the question still remains as to the extent to which these results of tachistoscopic reading with exposures of a few thousands of a second are directly applicable to reading in the usual way. The results of the present investigation will, it is hoped, offer some evidence on this point.

There is, on the other hand, evidence to support the observation that the threshold of perception of the domineering letters, to use Messmer's terminology, is (in the tachistoscopic reading) lower than that of the other letters,—although the much greater time of stimulation may, as suggested, in ordinary reading make this observation of comparatively little general importance. A study of the tables of readings that are given by Messmer shows, for instance, that *in the comparatively few cases* where isolated letters are perceived, they are usually domineering. (The following letters were the only ones perceived apart from the other letters, given in the order that they are found in Messmer's tables (pp. 202-204) i, k, h, w, g, k, g, h, b, gew, sch, her, ge, b, d, w, i, ch, ge, S, nnen).¹

But this fact does not in the least support the theory that several of these letters are perceived in succession before other letters. In fact, the tables of Messmer point to the opposite theory; for, if there were successive perception, one would possibly expect to find an occasional perception of a series of domineering letters as h, t, fl, etc., whereas with the exception of the above letters, and 'ärts,' and 'he' of 'heimwärtssfliehenden,' every other partial perception of a word is by *syllables*, and not by domineering letter combinations. The original contention of Erdmann and Dodge holds good

¹ These are not so given by Messmer, but are collected from his tables by the writer.

that while some letters undoubtedly condition the total-word form more than others ("Words of characteristic optical 'Gesamtform' are more easily recognized than those of undifferentiated (gleichförmiger) configuration." *Op. cit.*, p. 157), yet the percept itself during a given exposure is unitary and simultaneous.

And, in ordinary reading, the facts brought out in the present investigation seem to the writer to justify the further conclusion that the foveal perception during any given fixation is simultaneous, and that when the attention is changed even to a smaller part of its original field, as in the case of a misspelled word (cf. gorgeously, Chart 62B), or to a letter out of alignment, as in proof reading, there is a change in the character and content of the resulting perception. The first perception of the word just noted was of its total word form, the second differed in that it was limited to a special scrutiny for the misspelling. Even such a small change in the point of attention usually causes a change in the point of fixation. This means that successive sections of the word command the centre of attention. Peripheral images are less vivid and clear than foveal, but they are always 'wholes.'

The extent or span of attention may also vary greatly. There is reason to believe, as will be shown later, that the general character of the whole line or a large part of it is often perceived during the first fixation. In order to accomplish this, the span of attention must not only be widened, but the attention may shift towards the periphery. In the latter case, it is believed that this change of attention is evidenced by a gradual movement of the eye towards the periphery, which, as has been pointed out, is most noticeable in the first fixations. This perception is quite different from that usual in the succeeding fixations as regards the definiteness of its peripheral content; but it is at the same time simultaneous for large groups of letters and words, the object being to obtain a rough impression of perhaps the length of the line and its general appearance. It is hard to believe that the succession proposed by these authors is not purely a matter of interpretation and that the succession is one of syllables and words and not in the first instance of short and domineering letters. These letters as far as perception is concerned are, except when specifically attended to, perceived as parts of larger wholes. When on the extreme periphery, they are seen only in rough outline and always in combination.

The movement of attention supposed by Zeitler and Messmer, would in the case of ordinary (non-tachistoscopic) reading presumably be limited to the field of the single fixation; they must, therefore, recognize a more general movement of attention from

one fixation to another. The latter change is the only one for which the writer finds evidence. The former hypothesis not only lacks experimental evidence, (difficult in either case to establish), but there are some experimental results which tend to disprove it. Becker¹ has made an interesting experiment of voluntarily separating the attention from fixation as a test of successive apprehension. To repeat somewhat for purposes of clearness:

“The general theory advocated by Wundt was that the unequally favorable position of the different parts of the field of view during fixation is rendered less noticeable through the fact that the point of attention moves successively to those letters which are distant from the point of fixation; a ‘searching’ (Absuchen), as it were, of the visual field thus occurs at each fixation. Such an hypothesis seems improbable in view of the difficulty which is ordinarily experienced in separating the points of attention and fixation, and the experiments made tend to disprove it.”

“In the first experiment [of Becker] the attention and fixation are centered together upon a letter lying in the primary line of regard; in the second experiment the attention is separated from the point fixated to a letter lying to the left of it. If a frequent change of attention occurs during the exposure, both letters ought to be equally well perceived in either instance. The results show, however, that in the first case the letters to the left are less often read, and in the second case the percentage of perception of the left letter is twice as great as in the first experiment.”¹

The writer has also subjected the hypothesis of Zeitler and Messmer to a further test. If a ‘searching’ by attention of the field of view occurs, it seems not unlikely, in view of the observed relation of fixation and attention, that the action of attention should have some effect on the accuracy or steadiness of fixation, which might be detected. Photographs have, therefore, been made of the eye while reading several phrases and sentences of four or five short words exposed for 10σ - 100σ .

In order to register on the negative along with the reflection from the cornea the exact time or point where the exposure began, the electrical circuit of the fall exposure apparatus was connected also with the spring pendulum and was closed previous to exposure, thus keeping the pendulum drawn to the magnet; the beginning of the exposure broke the circuit and released the

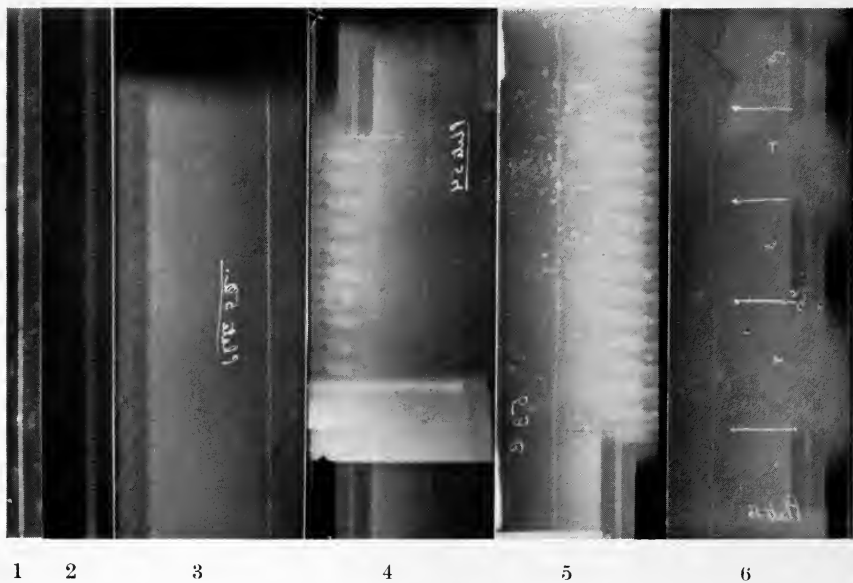
¹ Op. cit.

¹ Quoted for convenience from the writer's review of the article of Becker in the *Journal of Philosophy, Psychology and Scientific Methods*, Aug., 1905.

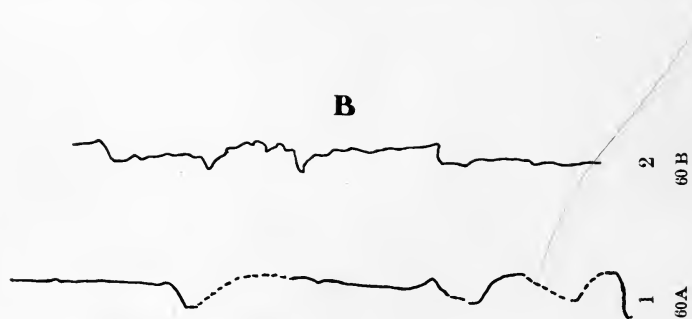


PLATE IV

A



B



pendulum. The vibrations of the pendulum then gave opportunity to determine how soon after the exposure any movements occurred, in case that should happen. The results of four records are as follows. A copy of one of the plates (2 records, Nos. 4 and 5) is reproduced in Plate IV.

DESCRIPTION OF PLATE IV.

(The records are one-third the size of the original records.)

1. Record showing the steadiness of apparatus and absence of lateral movement in the falling plate. It is a registration of the reflection of light from a gilded bead placed in the head rest.

2. Vibrations of Koenig tuning fork (vibrating 100 per second) cf. Pl. II. The horizontal knife lines at every 19 vibrations represent the incidence of the oscillations of the spring pendulum.

3. Steadiness of fixation. Record shows the degree of steadiness in fixation which it is possible at times to maintain for a short interval. The oscillations of the pendulum appear on the left side of this print; the light is admitted to this part of the negative only through a small aperture in pendulum.

4. Record No. 54. Tachistoscopic reading. (This print was by mistake inverted, i. e., mounted upside down, the beginning of record is at the top edge of page.) The arrow marks the beginning of the exposure. Note that the unsteadiness of the eye begins a little *before* the actual exposure.

5. Record No. 53b. Same as No. 4.

6. Effect of the recollection of memorized passages upon the steadiness of fixation. The arrows denote the beginning of new lines (of poetry) in the recitation.

Plate IV. B. Line drawings of eye movements in the visual recall of memorized passages. (See text.)

In two of the records there is absolutely no evidence of any movement or unsteadiness of the eyes. This is surprising in view of the difficulty of maintaining steadiness. In the other two records (those reproduced in Plate IV, Nos. 4 and 5) there is some unsteadiness of the eye at the time of exposure. Since, however, in each case the unsteadiness *begins about 40σ before the beginning of the exposure, it is clearly not due to a movement of attention*, but simply due to the muscular tension of maintaining fixations previous to the exposure. The unsteadiness lasts for an equal or somewhat longer time after the exposure. It is also interesting to note that these (33B and 34A) were the last two records taken. Several intervening exposures were made, and the fatigue of maintaining preliminary fixation may have had something to do with the increased unsteadiness. If the attention moved about as argued by the above writers, its movements would often be of much larger extent than the usual interfixation movement. It seems unlikely that such changes should in one case cause a *change of fixation* and in the other case produce no effect on even the steadiness of the eye. If, on the other hand, perception is simultaneous

for the given area in question, and the attention changes only when its field is extended, or contracted to a smaller area of the same field, we would naturally expect no change of fixation, as in the present instance.

Finally, the movement of attention supposed by these authors does not differ either in its purpose or, in many cases at least, in its extent from that which accompanies every change of fixation. In one case, however, there is always a physiological accompaniment, in the other, none. The purpose of the change during fixation is, according to the Wundtian theory, to equalize the unequally favorable portions of the field of view; accordingly, the change in this case must not infrequently cover an extent of twenty-six letters,—indeed the theory was invented to explain such extensive perceptions,—that is, an extent of reading matter larger than that covered by the average change of attention which accompanies fixation. It is certainly necessary to explain how such movements of attention could occur without affecting the steadiness of fixation. One more objection may be made by the defender of successive perception to the above experiment, namely, that in the case of the short exposure the disappearance of the objective stimulus renders a change of fixation useless. It is, therefore, inhibited, although the movement of the attention itself is carried out. This point is discussed in the following section.

CHAPTER VII

VISUAL PROCESSES INVOLVED IN RECOLLECTING

But is it true that the continued presence of the objects of perception is essential in order that a change of the attention may 'release' the motor discharge of the eye muscles; and, if so, is the inhibition of movement always successful? The results of another experiment seem to the writer to offer some evidence upon this question. That which we ordinarily do when we run over in 'our mind's eye' the lines of a page which we have just been reading or of a passage which we have committed to memory offers an instance of a movement of attention over a field that is not present to the visual sense, except as a memory image. The fading after-images of the short exposure must furnish a much more objective basis for motor discharge than those recalled after an interval of time has elapsed. Is, however, the recall attended by eye movement? The experiment was made in two parts. In the first case the subject, while stationed before the camera and looking straight ahead at a white cardboard placed at ordinary distance in lieu of a page of print, repeated a stanza of Longfellow's *Evangeline* which had been previously memorized. He was asked to repeat it to himself in a just audible tone much as he would do naturally if by himself. Of the subjects employed one was quite unaware of the purpose of the experiment, the other was familiar with it. (Cf. Plate IV, No. 6.) Since, however, small movements or unsteadiness of the eye are not subject to voluntary control, knowledge of the purpose of the experiment could hardly have any effect on the results. The second division of the experiment differed from the first in only one particular, the subject was instructed to try to hold in mind a visual image of the page as the lines were repeated.

In order to be able to tell what part of the passage corresponded to any given point in the records, just as the last word of each line was repeated by the subject, the experimenter closed or opened alternately an electric switch controlling an indicator. The movements of the indicator were recorded in the plate at the side of the corneal reflection, as described above. A record (of the subject who was unfamiliar with the object of the experiment) is reproduced on Plate IV, No. 6. As may be noted there is consid-

erable eye movement during the recitation. The movement, moreover, is not that of mere unsteadiness of the eye, but there are several changes of position which closely resemble the true interfixation movements. In this case the subject was 'holding in mind' the visual image of the page.

When the passages were merely repeated, the movement was not so marked, (the motor discharge moving perhaps into other paths more naturally, e. g., the auditory-motor system.) A difficulty in recalling parts of the passage quite unconsciously contributed to the value of one of the records. The hesitation and attempt to remember accentuated the eye's movements. Several changes of fixation nearly equaling in extent a movement from the end of one line to the beginning of the next are made during this confusion. This record and also the records of this subject when instructed to keep in mind the appearance of the page can unfortunately not be directly reproduced because of the faintness of the negative. A careful pen drawing of the distinct parts of the records may be found on Plate IV, B. The second drawing (No. 2 in Plate) (60B) (subject trying to secure visual image of words of page as he spoke them) shows not a little resemblance to the usual fixation pauses and movements. Several long movements like the usual return sweeps of the eye are of most interest. These long uninterrupted movements are introspectively the most prominent of our motor sensations. They are in fact practically the only sensations of eye movement which most persons have.

Individual differences are to be expected, dependent possibly on the closeness with which the subject approximates the visualist type. As is well known, many can recall during the recitation of a memorized passage a pretty constant image of the general appearance of the page and of an occasional word or group of words. The records of the second subject are more conclusive than those of the first, due doubtless to an individual difference in this respect. They show that, if there is a distinct change of the point of attention, a corresponding eye movement may occur even if the object is only imagined. Since during the period immediately following the momentary stimulation of the short exposure with the tachistoscope the image of the words exposed is held in mind for a brief moment in a way not unlike that of the above experiment, it seems likely that, if in that case, too, the changes of attention,—often of wide extent,—assumed to occur upon the Wundtian hypothesis, did actually take place, they could not fail to have a physiological effect upon the eye's fixation similar to the above described motor phenomena.

CHAPTER VIII

THE DURATION OF THE FIXATION PAUSES

§ 1. *Relation to the Number of Pauses*

The more pauses there are in a line the shorter their lengths on the average, and, vice versa, the fewer the pauses the longer any one pause is apt to be. The number and duration of the pauses must, therefore, be considered together in an analysis of their functions. Viewed simply from the standpoint of speed of reading, it is in general an advantage to read a given line with the smallest possible number of pauses, because while the elimination of a pause increases somewhat the average duration of the remaining pauses, the total time for the line is decreased, or remains constant. In the third reading of the first line of the newspaper passage by H (Chart I, p. 75), for example, the average time of the four fixations was 215σ ; in the fourth reading three fixations are made with their average length 286σ , but the third as a whole took the same time as the fourth (860σ); similarly, in the second reading of the second line the total time for four fixations was 950σ , that for the third and fourth readings in three fixations each 670σ and 820σ respectively.

Other comparisons of this fact can be made from the Chart I of fixation pauses on p. 75. When, on the other hand, we regard the matter with reference to the differences of words in ease of recognition and assimilation, as, for instance, if we wish to determine what words and sentences are from this standpoint best suited to be put into an elementary school reader, the length of the single fixations and not their number becomes most important. To refer again to the chart (I) on p. 75, although the number of fixations is about the same, the fourth line has a little advantage in the time that is needed for recognition and assimilation.

The average durations of the fixation pauses of five subjects (see Table VIII) in reading the same newspaper passage were (Subject T) 160.82σ (A. D. 36.8); (Subject H) 216σ (A. D. 50); Subject S) 255.5σ (A. D. 87); (Subject F) 401.9σ (A. D. 163.7); (Subject M) 196σ (A. D. 79.9). In reading a scientific passage taken from the *Popular Science Monthly*, the average for T was 169.41σ (A. D. 53.01); for H 241σ (A. D. 67.3), and for Subject

S 253.57 σ (A. D. 102.7 σ).¹ These differences between subjects are naturally very closely correlated with their differences in the rapidity of reading, as determined by these tests and by others given independently. In the accompanying charts, pp. 75-82, the duration of the pauses in each line and the total and average lengths have been denoted, and on pp. 77-80, several lines of the newspaper column are put in immediate succession for better comparison of these apperceptive differences of the subjects. In the following table (Table VIII, A-D) the average number of fixations has been given with the average and median lengths for several passages. The larger number of pauses in the longer lines shows that the total time per line was, of course, much longer.

TABLE VIII

The average and median durations (in σ) of the fixation pauses of different subjects in reading the same pages

A. A newspaper column.

Width of line 57 mm. Height of type 1.5 mm.

	Av.	M.	A. D.	Av. No. of pauses per line.
Sub. T.	160.8	152	36.8	3.7
" H.	216.	220	50	3.9
" S.	255.5	238	87	5.5-6
" F.	401.9	240	163.7	5.4
" M.	196	160	79.9	7

B. 'A License to teach.'

Width of line 96.5 mm. Height of type 1.5 mm.

	Av.	M.	A. D.	Av. No. of pauses per line.
Sub. H.	211.6	186	68.7	6.
" S.	200.7	186	61.0	7
" F.	295.3	277	91.3	8.5
" St.	275.9	257	67.2	5.3

C. Athletics.

Width of line 107.5 mm. Height of type 1.5 mm.

Sub. St.	215.2	199.8	54.3	5.6
----------	-------	-------	------	-----

D. A scientific article.

Width of line 107.5 mm. Height of type 1.5 mm.

	Av.	M.	A. D.	Av. No. of pauses per line.
Sub. T.	169.4	150	53.0	6.5
" H.	241	218	67.3	5.4
" S.	253.5	200	102.7	7.5

¹ The times given for these pauses are accurate within ten sigma. For purpose of securing as many lines of reading as possible on one negative, the rate of fall of the photographic plate was made very slow. The long duration of the fixations makes such determinations sufficiently accurate for the purpose in hand. With a faster fall, the records can be read to 1 σ .

§ 2. *The Length of Fixation and the Reaction Time of the Eye*

The length of fixation pauses must also be conditioned by the reaction time of the eye. Dodge¹ found the mean reaction time for two subjects to be 162σ and 170σ . The minimum reactions were as short as 140σ . As remarked by Huey,² however, "In reading it may well be . . . that the reaction is somewhat . . . quicker, (Huey's own determinations were longer than the above due possibly to the weight of the eye cup and pointer, i. e., 206.7σ M. V. 20.7σ for visual stimuli) because of the heightened readiness for the stimuli produced by 'associative expectancy' and, perhaps, also, by the stimulus to reaction having been actually noted in the remote periphery even while the eye is fixated in the preceding line;" and the result of his measurements of the average length of pause for one passage 190.9σ , M. V. 48.6σ ; for another passage 108.3σ , M. V. 32.6σ ; and for a third passage 183σ support this supposition. While the average times of the reading pause are, however, as above determined in the experiments, in excess of the minimum reaction time, they are not infrequently much shorter, due doubtless to the above explanation, which indeed amounts to a distinct difference in the method of experimentation.

¹ *Psychological Review*. Sept., 1899.

² *American Journal of Psychology*, XI, 295.

CHAPTER IX

THE SPAN OF ATTENTION AND THE DURATION OF PAUSES

It is natural to suppose that the length of time the eye spends at any one part of the line is somewhat indicative of the apperceptive qualities of those words. This is, however, not literally true. The attention is often distracted by matter lying on the extreme periphery and by words immediately above and below in other lines. It has already been argued that the eye *tends* to follow each shift of the attention in order to bring the object nearer the fovea, and that the unsteadiness of fixations is due to the acute unbalance and general alertness of attention to peripheral excitation. It is certain at any rate that within the rather long duration of the fixation pause the attention is, so to speak, distributed over the immediate field of view. The duration of any one pause need not, therefore, necessarily represent the time that is necessary to perceive the words immediately fixated, although it may do so approximately.

The first noticeable instance in point is that of the first fixation in each line. As may be seen from the distribution of lengths of pauses according to their order in the line, the longest pause in the line is very regularly found at the first fixation. Since it is evident that the more difficult parts of the line do not always come first, some other explanation must be sought. The fact is illustrated in the distribution in Table IX A. The median durations of the first and following fixations in reading several lines of a newspaper column are there compared.

TABLE IX

The median durations (in σ) of fixation pauses distributed according to their order in the line

		A. Newspaper column. Length of line 56.6 mm.													
Subject	1st fixation		2d fixation		3d fixation		4th fixation		5th fixation		6th fixation		7th fixation		
	M	AD	M	AD	M	AD	M	AD	M	AD	M	AD	M	AD	
T	190	26.4	148	16.5	151	29.4	152	54.1							
H	210	43.3	190	27.3	205	32.9	220	41.4	140	40.					
S	280	62.9	306	72.9	194	127.7	238	65.1	221.5	65.5	243	61.4	144	45.	
		B. Scientific passage.													
Subject	M AD		M AD		M AD		M AD		M AD		M AD		M AD		
	M	AD	M	AD	M	AD	M	AD	M	AD	M	AD	M	AD	
T	160	80.	170	34.3	160	47.1	140	20.	150	27.1	155	23.	140	13.3	
S	160	58.	200	64.	200	32.	200	20.	200	202	190	122	370	214	

It will be noted that the median durations of the first pauses in the case of subjects T and H are longer than those of the succeeding pauses. The most reasonable explanation of this fact seems to be that the eye here takes a much more general survey of the line as a whole than it does ordinarily in the later fixation pauses. Another explanation which suggests itself is that the attention may be distributed both to the left and right in the case of the first fixation. That is, as the eye seldom comes back to the very edge of the line, matter lying both to the left and right of the line of regard must be perceived together. This would not be the case in the following fixations. The direction of attention after the first pause would be always in the line of the eye's advance. It is possible to test this last hypothesis in the cases much more frequent in some subjects than others where the fixation does actually return to the very edge of the line. The first fixation ought in these cases to be shorter, that is, of the same average length of the other fixations in the line. But an examination of the records shows that this is not the case. As will be further noted in another connection it is, therefore, more in accord with the facts to suppose that in all fixations the perceptive process is generally concerned with the matter lying on either side of the point immediately fixated and that when the first pause is longer than the average of the other pauses in the line it denotes a more general survey of the whole line.

It will be further noted by a comparison of Table A (the newspaper readings) that in the case of subjects T and H there is a second increase in the distribution of the length of pauses in the third and fourth fixations. This may be considered to indicate that the 'general survey' of the first pause covered the end of the lines only superficially, and the last two fixations are, therefore, somewhat longer than the second or intermediary but not as long as the first. In the case of the third subject there is a partial alteration of long and short pauses. This on a basis of the previous hypothesis may be taken to indicate that the extent or span of attention is usually smaller than in the other two subjects. This, of course, has already been indicated by the larger number of pauses per line, but the one may not improbably be the cause in part of the other. The subjects who can make at the beginning and elsewhere a more general survey of the line than is done in the intermediary pauses may for that reason read the remaining part of the line with fewer pauses. Although the number of cases measured is small, it is further interesting to note that this 'wider spanning' of the attention, if this is the true explanation of the longer initial pauses, is made more frequently by the more rapid

readers. It seems to point to another differentiation and cause of the individual variations in the velocity of reading, and it might be naturally expected that a certain amount of 'prevision' would contribute to the grasping of larger units of thought than when the attention is more contracted. As just said, it may be for this reason that the rapid readers need to make fewer pauses per line. The facts, in a word, justify the conclusion, that the attention is much more widely 'distributed' at some pauses than at others—of this there is really no question, the different extents of line between the fixations must be explained on some such hypothesis,—and, secondly, that the frequent occurrence of a longer initial pause shows that the lengths of the fixations are not solely dependent upon the apperceptive character of the words or phrases more immediately attended to, but that they are presumably influenced by other parts of the sentence, i. e., the assimilative attention is more widely extended in some pauses than in others. The explanation given above for the so-called 'shifting' movements in the direction of the eye advances, is none other than this, i. e., the attention is ahead and 'pulling' the eye along.

In the distribution in Table IX B of the durations of the fixations in a longer length of line the first fixation is not longer than the average. It is to be noted here, however, that at the beginning of nearly every line there is a 'refixation.' This means that in the first fixation the attention is directed to the left and towards the edge of the page, and cannot, clearly, then, perform the function of scanning the line as a whole to the right. It may also be that in this case the involved style necessitated a more contracted span of attention and gives little opportunity for grasping the larger units of thought. If, however, the refixations are counted in together with the first fixation pause,—and there is good reason for doing this, since only when taken together do they represent the full amount of time spent at the beginning of the line,—the above discussed phenomenon holds equally good of this latter passage. One other factor must also be taken into account, that is, the greater length of text-line in the second passage. It is quite possible that a longer initial pause in a line of this length would be of but comparatively little value because, first, the perception of the extreme periphery would be much less distinct, and, secondly, because the greater separation in the long line of those phrases and clauses which belong together may make such prevision relatively more difficult. (See Chapter XII for further elaboration of this point.) The question as to which one of these factors, style, length of line, etc., gives the correct solution to the problem is finally discussed in Chapter XII, where new data concerning the phenomenon is presented.

§ 1. *Experimental Isolation of the Reading Pause*

Although, in view of the preceding, perception cannot be considered as limited to the period of fixation, valuable data has been secured and may yet be expected from the experimental isolation of the reading pause. A method for further investigation which for some purposes has several advantages over that of the fall exposure apparatus and the tachistoscope is the following. If words and short sentences are arranged, as the following series of nonsense syllables, p. 66, at such a distance apart that when the eye is fixating one, the other is not within the range of clear vision, there will be but a minimal disturbing influence of irrelevant matter, and the length of the pause will be approximately that which would be made in actual reading. As the length of any pause depends in part upon the difficulty of recognition and perception, a comparison can be made of the words and phrases in this respect, and, secondly, the extent of the line that may naturally be perceived together when the eye is freed from other distracting elements at the periphery and in the lines above can be determined. For, if the group becomes too large, a second fixation will be made. As an illustration a print is made on Plate V, 1, of the length of time spent by the eye in the perception and assimilation of the following series of nonsense words. The eye, as will be seen from the print, followed the arrangement of words and made but five pauses in each horizontal line.

Several factors which may be differentiated by further experiments evidently enter into the assimilation or apperception of the nonsense syllables. A study of these elements should throw light on the process of word apperception in general. The length of the pause is due in part to the sequence of letters. If that is the normal or more common sequence of words, such as 'werq,' 'wopi,' 'gero,' 'apli,' 'enfa,' the association process is less interfered with; such combinations as 'ciuo,' 'weao,' 'dpiu,' disappoint the associative expectancy and the time taken for perception is longer. A second and perhaps more important element is that of the ease of pronunciation. The syllables last mentioned, 'ciuo,' 'dpiu,' 'weao,' etc., as well as others like 'fiea,' are evidently much more difficult to pronounce at sight than 'wopi,' 'gero,' 'werq' and even 'fhwe.' Articulation or some form of motor expression is undoubtedly one of the factors which determine the length of the fixation pauses in general and its influence presumably varies with different individuals, the rate of reading of some apparently being not faster than some form of motor expression. I have made comparison, for example, of the tables of the rate of reading of twenty or more subjects as

given by Quantz¹ and Huey² with a view to this question. The differences in the speed of reading silently in the usual way among one class of subjects differ in a ratio of 2.5 to 1,³ i. e., the fastest are 2.5 times as rapid as the slowest. But in reading aloud they are only about a third faster. This is, of course, due in part to the real physiological difference in the time of articulation, but it seems also to show that the fastest readers had curtailed the motor expression most in their usual method of reading.

LISTS OF NONSENSE WORDS

SFAG	TUIE	WERQ	TIOE	ERSA
ASSE	GERO	BERA	YUIE	GHEI
REWO	FIEA	WOPI	FHWE	EIHU
CIUO	EIDO	APLI	TUGA	EOFU
VOEI	SAEI	TIUE	EUFA	OIJU
RUIA	WEAO	DPIU	BEWA	VIUE

¹ 'Problems in the Psychology of Reading.' *Psychological Review*, Monograph Supplements, Vol. II.

² Op. cit.

³ These calculations are not given by the authors quoted but are made by the writer.

CHAPTER X

THE NUMBER SPAN OF ATTENTION

A similar experiment has been made with numbers. Numbers for reasons which are discussed later are well suited to an experiment of this sort, chiefly because in reading them the span of attention is more limited to the area of the immediate fixation pause than in reading of words or even of nonsense material.

The results of the experiments as given below show that it takes an appreciably longer time (2101 σ) to read a series of twenty-four numerals when grouped as fours than when grouped as threes. The reading of larger groups of five and six figures demands a proportionately longer time. The reason for this fact is, it is believed, that the groups of numerals are not read as wholes, as words usually are, but by their separate digits. The process of analyzing and recombining the larger groups makes a greater demand on attention which, as denoted by the greater duration of the fixation pauses, is proportionate in almost geometrical ratio to the number of digits in the groups.

Why should numerals differ from words in this respect? The pathological cases cited by Brandenburg, as Störrung¹ has shown, point to a difference in the central connections between words and numerals, and as well between the names of numerals (i. e., written with letters) and the figures themselves. The subjects had lost completely the capacity to read words and single letters, but they could read numbers 'ganz fließend,' even up to five or more digits. The explanation of the difference is that if the subject could read a single number he could easily read several, as it would be simply a matter of position; whereas if the subject could read letters it would be no indication that he could read words. (The now well-known cases cited by Leube and Löwenfeld, in which the patients were not able to read letter by letter but only when the total word was seen, show "that the Gesamtbild of the word can at all events play an important part, and that reading does not need to proceed letter by letter."² A series of figures, to put the matter another way, cannot acquire the independent significance which words do, and that because the succession of letters is always the

¹ Störrung, *Vorlesungen über Psychopathologie*, 165 ff. Leipzig, 1900.

² Störrung. *Op. cit.*, 163, 164.

same and unchangeable in a given word, but in a series of numbers the possible variation is almost infinitely large. It is to be expected, therefore, that in reading numbers the attention is concerned with much smaller units than in reading words. And this proves to be the case.

The method of experiment has already been indicated. The results of one subject will be discussed for illustration. In the first record twenty-four figures were spaced in groups of threes. There were two lines of these groups. In the third line the digits were printed consecutively without spacing. In the second record the same number of numerals was grouped by fours and a similar unspaced line of twenty-four was printed below it. The third record was of mixed groups of numerals of from two to six digits. The original pages were typewritten. They are reproduced here in as nearly similar type and spacing as possible. The photographic records are reproduced in Pl. V, Nos. 3 and 4. No. 2 is the reading of an unspaced line of numerals by another subject.

473 869 673 695 938 593 583 984

948 374 567 284 736 927 684 734

473829483746583928473645

748392837465738293847564

5849 9426 5748 2938 8493 75849¹

758493827364537284938475

8695 3847 7483 5928 5748 8493

875893827364527384958773

¹This last group through a mistake of the typewriter was made of five digits instead of four.

The time taken to read the two lines of eight groups of three figures was practically the same (3625σ in one case, 3610σ in the other, or an average of 452σ for each group of three). The time, however, taken to read the six groups of four digits was 5727σ or an average for each group of 955σ . The results of the experiment came as a surprise to the subjects (the results of two other subjects and with different series were similar). Introspectively it seemed to the subjects that the groups of threes and fours were perceived as wholes and with equal facility. The next part of the experiment further illustrates where the difficulty lies. The subjects were instructed in reading the unspaced lines to group them in reading in the first case by threes and in the second case by fours. This the subjects believed that they did successfully. The only difficulty noted introspectively was that the 'eye ran too far ahead of the group that was to be singled out, necessitating some backward movements.' The record shows that this is somewhat the case particularly in the grouping by fours. The result was similar to that in the spaced groups. The total time taken for reading the twenty-four letters by threes was 5068σ , by fours 6247σ . The exact series and arrangement of the third experiment is given below, and below it¹ the times taken to read each group. The photographic record of this experiment was omitted by mistake and is inserted at the end of Plate V as No. 14.

287	4936	892	58763
689243	832	9477	28
3344	92	899	43621
93	482	998763	29

Times in σ taken to read the above numerals grouped as above

¹ On next page.

443	824	451	964
1658	410	824	410
857	284	451	1148
451	476	1895

The reason which seems to the writer to underlie these differences in the time taken to read two digits and six digits has already been suggested. It does not ordinarily take any longer (see charts below) to read a long word of ten letters than it does to read a short word of three, in fact, as will be seen, the small word may cause the greater difficulty. This seems to justify but one conclusion, the words are read as wholes; and the fact that there is a constantly increasing ratio of time taken in reading the larger numbers shows that the latter are not so read. The innervation is split up and, as said, it is first necessary to analyze and then combine into wholes. The experiment with the unspaced line of numerals further illustrates that under the exactly similar circumstances it is harder to pick out a group of four numbers and then combine them than it is to analyze and unify a group of three.

If the attention is in these readings analytic, so to speak, this should supply a fair test of the above described hypothesis that the changes of the attention in perception will cause corresponding movements of the eyes even within the small limits indicated. Are such changes in the location of the fixation pauses to be discovered in the records? For purposes of comparison prints of two of the negatives have been reproduced on Plate V, one of the readings by threes and the other of the groups of four digits. The prints do not, unfortunately, show the minute changes as well as the negatives themselves. The small shifts of the bright point can be easily detected in the original records, by small differences in the intensity of the impression on the negative. If the eye remains for even an almost unmeasurable fraction of a second longer in one place than in another, the film is sensitive enough to cause a differentiation in the 'depth' of the impression. The general penumbra tends to obscure this, but the difference can be clearly detected when the record is held before a bright light. These minute but exact differences are quite indiscernible in the prints, espe-

cially as the records are reduced in making the plates. However, a careful comparison of the prints of the readings of sentences and those of the numerals will show unmistakably that the fixation of the eye in one case is usually without noticeable shifts, whereas from two to five separate and distinct breaks can in most cases be detected in the fixations of the numerals. When the number is over four, one or more of the movements is regressive. In the record representing the reading of the unspaced line of twenty-four digits no less than thirty changes or shifts of the bright point can be counted. This shows that the eye necessarily moved back and forth somewhat in analyzing and combining the separate digits into the prescribed units. *And it is the contention of the writer that if a similar process of analysis and combination were gone through with by the attention in reading the words and domineering letter complexes, etc., there would necessarily be some similar indication in the angular displacement of the line of regard.*

These differences appear in the reading of numerals only because the process of perception in the latter case is materially different from that which takes place in the reading of words. In reading groups of three or more numerals the process of innervation is broken into smaller divisions;¹ in the reading of familiar words and phrases, it is a unit coextensive with the whole immediate area of the fixation. Groups of numerals (except in the case of familiar dates, as 1905, which are exceptions that prove the rule) are so seldom made up of the same series of digits that they never acquire a 'Gesamtbild,' and are therefore recognized as totals only after a successive perception of the digits has taken place.

The case is exactly similar in the reading of groups or lines of consonants; where vowels are added as in nonsense words, the

¹ Although records were also made at the time the above were taken to determine whether even groups of two are regularly recognized as wholes, they are not accessible, and there has not been opportunity to repeat them. The records of the readings of Nos. 28 (2nd line, No. 4); 92, (3rd line, No. 2); and 93 (4th line, No. 1), (see Pl. V, 14), as well as the number of separate movements in the groups of four seem sufficient evidence that the single digit is often the unit.

The results for at least these subjects evidently do not agree with the conclusions of the tachistoscopic experiments quoted earlier that "on the average consciousness can at one time grasp four numbers, three to four letters," etc. The discrepancy is found also in the perception of words but not to the same extent for the same subjects. If the interpretation given above of the purpose and significance of the fixation pauses is correct, it must presumably be conceded that (1) the results of tachistoscopic experiments cannot be applied directly to reading, and that (2) a greater dependence is put upon the visual memory image of the perception in the former case than in the ordinary practice. That is, either (1) the actual extent of matter assimilated is greater in the short exposures, and (2), since the text is no longer before his eyes, the subject has learned from a little practice to depend more on the visual memory images than is customary in ordinary reading.

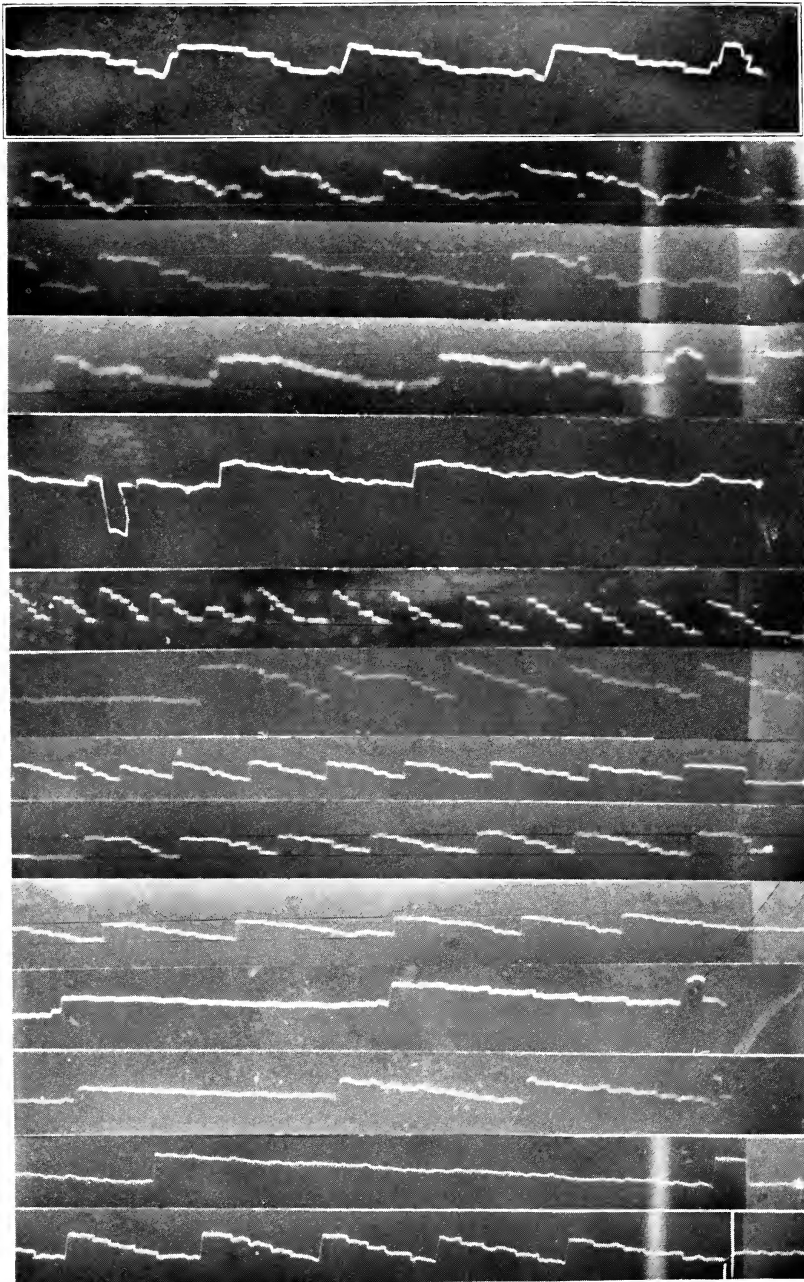
span of attention is somewhat widened by the occasional recognition of a familiar syllable.

This is the significance of the difference in the time of perception of words of increasing complexity, as determined by Cattell, and the numbers of increasing digits, as determined by Friedrich. Cattell found (*Phil. Studien*, III) that the recognition of one short English word from a set of twenty-six took 360σ , a short German word 367σ , and a long English word 375σ . Here was an increase of but 15σ . Friedrich found (cf. Jastrow, 'The Time Relations of Mental Phenomena Table,' pp. 32-33) the reading time of one place numbers to be 318σ (simple reaction time 186σ), for three place numbers 397σ , and for five place 697σ . The increase in the complexity of the words was much greater than that of the numerals, but the time taken was shorter because the plurality was more of a unit in the case of words than that of numerals, which could not be grouped, for the reasons assigned. It will be shown in the following charts (Chapter XI) that in many instances the long word took no more, and perchance even less time than the short, because by means of abbreviated cues its real conscious significance was no more complex than the short word, and not only did not demand an analysis by a fluctuation of attention, but its abbreviated cue made its recognition even quicker than in the case of the short word. The original results of Cattell for lines, figures and letters illustrate and substantiate this conclusion as well as any. A series of short lines is most easily grouped, secondly figures, and least easily nonsense words, i. e., disconnected letters. The rate of error in the letters increases most rapidly because the natural word association is at every increase more difficult, whereas the analysis of the larger groups of numerals is not so difficult because we are accustomed to divide them into sections, and secondly, there are no interfering associations as in letters. The increase in time although marked is for this reason much less in the case of numbers. The lines are homogeneous and for this reason more of them can be perceived at one time than in the case of either letters or numbers.

The question of the distribution or fluctuation of attention simply resolves then into one of the success or failure in forming unitary groups.

The experiments of Hylan on the distribution of attention (*Psychological Review*, 1903), reinforce this point. We perceive successively that which has no connection, but as soon as connection appears between the isolated perceptions, they tend to be unified; our perception is no longer successive. It appears (Cf., p. 500) that the perception of isolated figures of increasing complexity was successive, as denoted by the regular increase in the time of reaction, but that with five figures this fluctuation and counting process could not go on in the time given. What expedient was then unconsciously adopted? They were grouped rhythmically into groups of one and two, or three or four, with the result that the reaction time was shortened. This grouping was not made by all subjects, and with the natural result that when the numbers were successively perceived, the reaction time was uni-

PLATE V



formly longer. Here again this individual difference in the inability to group into units appears, and it would be interesting to know if this inability was not closely correlated with the rate of reading of the different persons.

The general conclusion is that there is strictly no such thing as a distribution of attention to disparate and unassociated things, and that such distribution is a psychological and logical impossibility. When things are isolated in association there is a fluctuation of attention between them. When by means of the many tricks of association they are grouped into a conscious unity, this fluctuation is no longer necessary. The whole of the attention is given to the process until another isolated factor is introduced, and the question is simply again renewed whether the fluctuation of attention must occur to keep them both before consciousness, or whether the new factor can in some way be linked to the previous complex.

DESCRIPTION OF PLATE V.

1. Reading of the list of nonsense words printed on page 66; 5 words to a line.
 2. Reading of series of unspaced numerals.
 3. (No. 70 A.) Reading of lines composed of eight groups of three digits (spaced in first two lines, unspaced in third line). (See Chart, p. 68.)
 4. (No. 70 B.) Reading of lines composed of six groups of four digits (spaced in first line, unspaced in second line). (Cf. Chart, p. 68.)
 5. No. 34 A.) Proof-reading.
 6. (No. 35 A.) Proof-reading.
 7. (No. 33 A.) Reading aloud or with articulation 'St. Petersburg,' etc. Subject H. Cf. Plate II, No. 5, for silent reading.
 8. (No. 42 A.) Reading aloud 'A license for promotion,' etc. Subject S. Cf. Plate II, No. 6, for silent reading.
 9. (No. 45 A.) Subject D. Reading from child's book.
10-13. Children's Reading.
 10. (No. 72.) Child, age 9.
 11. (No. 25.) Child, age 10.
 12. (No. 21.) Child, age 11.
 13. (No. 22.) Child, age 11.
 14. (No. 71.) Reading lines composed of groups of two to six digits.
-

CHAPTER XI

THE LOCATION OF THE FIXATION PAUSES

§ 1. *The Location of Pauses in Ordinary Reading*

The experimental methods which have been hitherto employed in investigating the reading process have been too inexact to plot with any considerable accuracy the parts of the lines directly fixated. It is on this account principally that little is known of the reasons why the fixations occur at one point in the line rather than at another. As preliminary to a discussion of these conditions, I have marked for examination and comparison the locations of the fixation pauses in the readings of several subjects and of several kinds of subject matter and line arrangement. (See Charts I-XI.) The general method of measurement has already been indicated above. A vertical line, as |, drawn at the letter or spacing denotes the 'Blickpunkt' of the eye in fixation; when the fixation is unsteady or shifts, a bracket, [, denotes the starting point and a parenthesis,), the end of the movement. When the shift is from left to right, the order of the signs is [), when from right to left it is ([. When the eye simply oscillates back and forth during fixation the limits of the movement are then marked by two brackets []. Sometimes the first fixation falls farther within the line than the second (cf. Refixations and Regressive Movements). This reversed order is denoted by the letters a, b, c. The duration of the pauses in sigma is placed as an index number at each sign, as

|²²⁵_b [³³⁰_a) (²²⁰_c |²³⁰_d |⁴¹⁰_e [²¹⁰_f]

This series of signs is made use of to indicate the following series of movements and fixations. The first fixation (a) fell short of the end of the line; during the pause of 225 sigma there was a gradual 'shifting' from left to right within the limits marked by the brackets and parenthesis; when the line of regard had reached the point denoted by the parenthesis, there was a rapid movement made back towards the left to the point marked by the straight line |b; the eye paused here 225σ; a forward movement was then made to the place indicated by the bracket |c. During this pause of 220σ the eye gradually shifted to the left as far as the parenthesis. The

next movement brought the line of regard to |d. This fixation was maintained without unsteadiness or shifting; the next advance was to |e at which point the eye paused for 410σ , the sixth fixation pause was made at f. Here the shifting of the eye was made now to the right and now to the left, for simplicity the limits only of this shifting in two directions are given, and they are marked by the two brackets facing each other. With this explanation it is believed no difficulty will be found in interpreting the signs.

At the right side of some charts a table is given of the number of pauses. The averages for the whole page are given at the end of the passages.

In Chart I A several readings of a newspaper column by the same subject H are arranged line by line for comparison. Only three lines of the first reading are given. The second reading was made a month after the first. The others were made in immediate succession after the second. Chart I B shows the first and fifteenth readings by another subject of this passage.

Chart II shows the location of the fixation pauses, etc., of five different subjects, T, H, S, F, and M, in reading this same newspaper column (of the day on which the experiments began). These readings are arranged line by line for better comparison.

Charts III to VI, (pp. 81-82), are the readings of four subjects, T, H, S, and St, respectively. The passage is one clipped from a current number of the *Popular Science Monthly*.

Charts VII to XI, (pp. 87-88), are the readings of five subjects of another passage from a school manual.

THE LOCATIONS OF THE FIXATION PAUSES

SUCCESSIVE READINGS BY THE SAME SUBJECT OF A NEWSPAPER COLUMN

No. of Record	CHART I A		No. of Pauses
	1		
5A	ST. PETE RSBUR G, Nov. 2. -Th e Ad(m)iralty		6
13B	ST. PE ⁴⁹⁰ (TE)RSBURG, [N]ov. 2. ¹⁴⁰ -The Ad ¹⁴⁰ (m)iralty ²³⁰		4
15A	ST. PET ²⁰⁰ ERSBURG, Nov. [2.-]The Adm ¹⁶⁰ (ira)lty ³⁴⁰		4
15B	ST. PETER ^b SBURG, Nov. 2.-The ⁴⁴⁰ Adm ²²⁰ (ira)lty ²⁰⁰		3

2

5A	has telegraphed [to th]e off[ic]ers of the Ba ltic	6
13B	has ³³⁰ telegra)phed to the o ³²⁰ fficers ¹⁶⁰ of the [Ba]ltic ²⁴⁰	4
15A	has telegraphed to the officers o[f] the Baltic	3
15B	has teleg raphed to th[e offi]cers of t[he] Baltic	3

3

5A	flee[t,)who [wer)e (left be]hind at Vigo [in order)	5
13B	fleet, wh ²³⁰ (o]wer ¹⁸⁰ [e)left behi ²⁴⁰ nd at Vigo ²⁶⁰ [in orde)r ¹⁵⁰	4
15A	fleet, [who) were left behind at V[igo)in order	4
15B	fleet, who wer ²⁸⁶ e left ¹⁷⁶ behind at Vigo in ²⁷⁵ order	3

4

13B	that the ¹⁹⁰ [y) might testify, and who were (on) ¹³⁰	4
15A	'[hat ²⁶⁴ ,they might(¹⁷⁶ te]stify, and [w ²⁰⁹ ho were on ¹⁴³	4
15B	that th ²⁷⁵ [ey)might tes ¹³² tify, and w ²⁴² [ho) were on ¹⁶⁵	4
13B	thei ¹²⁰ r (way] to St. Petersbur ²²⁰ [g, to re)mai(n) in ¹⁶⁰	4
15A	the ^b [ir way] to St. Petersbur ^a [g, to remain in ²⁴²	2
15B	their way to St. Petersburg, to remain in ²⁶⁴ ²⁷⁵ ¹⁷⁶	3
13B	P aris.	
15A	P aris.	
15B	P aris.	

I B AND C

FIRST AND FIFTEENTH READING OF SAME PASSAGE BY ANOTHER SUBJECT

CHART I B

[ST.] PETER(SB)URG, Nov. 2.— (Th)e Admiralty	416	442	186	340	4						
[)has telegra[phed] to th[e of]ficers of th[e Baltic	314	144	306	238	263	136	7				
fleet, who w(er)e left behind [at] Vigo i]n order	a	280	b	323	c	175	d	218	218	315	6
[th)at they might testify, and who[w]ere on	225	333	135	198	225	243	144	7			
thei[way)to St. Petersb]urg, to re main in	407	212	148	268	74	5					
[Paris.)											
[Admir]al Kaznakoff, a mem(b]er of th[e	212	249	194	397	120	129	6				
Admir[alt]y Council,[)who w]as appo]inted	342	333	231	203	4						
yest(er)day upon(th)e in(te)r]national com[-]	258	452	333	323	4						
[mission whic]h is to i]nquire int(o) the [N]orth	328	180	875	142	342	142	6				

Av. duration, 225.5σ; A. D., 87σ; M., 238σ.

Av. 5.4
A. D. 1.1

CHART I C

	ST. P ³⁶⁰ (ET)ERSBURG, Nov ²⁴⁸ [.)2.—The ¹²⁰ Admiralty	3
	has ²³⁷ [te]legraphed ²²⁹ t ¹⁸⁹ o the officers ¹⁸⁹ of the Baltic	3
	fleet, w ⁶⁷⁸ [ho] were ¹³² left behind a ¹⁴⁸ t Vigo i ¹⁰⁹ n order	4
	that [they] might ²⁰⁰ t ¹⁵⁴ estify, and w ²⁰⁷ [ho] were on	3
	their ¹⁵² [w]ay ²⁵⁸ t ¹⁴⁴ o St. Pete ¹⁷⁴ rsburg, to r ³⁶⁷ emain in	4
	Pari ³⁶⁷ [s.]	
	Ad ³⁶⁷ [miral] Kaznakoff, a ^a [m]ember o ¹³⁵ f the ⁷⁵	3
	Admira ²¹⁴ [lty)Council, who was ²¹⁴ (a)ppointe ¹⁴⁸ d	3
233 b	[y]esterday upon the international com- ^a	2
	Av. duration, 212.3σ; A. D., 72.2σ; M., 189.6σ.	Av. 3.3 A. D. .4

CHART II

READINGS BY FIVE SUBJECTS OF THE SAME NEWSPAPER PASSAGE

Subjects		No. of Pauses
	1	
T	ST. PE ³⁴² (TE)RSBUR ¹⁵² [G, No ¹⁵² [v.) 2.—Th ³⁶¹ e Admiralty	4
H	ST. PE ⁴⁹⁰ [TE]RSBURG, [N]ov. 2.-- The Ad ¹⁴⁰ [m]iralty ²⁵⁰	4
S	[ST.]PETER ⁴¹⁶ S ³⁰⁶ (B)UR ¹³⁶ G, Nov]. 2.—(Th ¹³⁶]e Admiralty ³⁴⁰	4
F	ST. P ⁶⁷⁰ ETERSBUR ^{b1} [G, Nov). 2.—The A ^{b2 1118} [dm]iralty ⁶⁴⁶	3
M	(S ⁸¹¹ [T. PE ¹⁴⁸]TER ¹⁴⁰ SBUR ¹⁷¹ [G,)No ³⁵¹ [v.) 2.—[Th]e Ad ¹⁶³ miralty ²⁷³	7
	2	
T	has telegraphed ¹²³ to the off ¹⁵² icers of the ²¹⁸ Baltic	3
H	ha ³³⁰ s telegra ²²⁰ phed to th ¹⁶⁰ e o ²⁴⁰ fficers] of the [Bal]tic	4
S	[] ⁸¹⁴ has telegra ¹⁴⁴ ph ³⁰⁶ (he) (d] ²³⁸ to th ²³⁸ e of]ficers of th ²⁶³ e Baltic ¹³⁶	7
F	has telegr ^{a 291} aphe ^{b 179} d to the ^{c 382} [o]fficers of the B ^{d 587} altic ^{e 329}	5
M	ha ²¹⁸ s telegraphed [to] the of ²³⁴ fice ²²⁶ rs of the Ba ¹⁷¹ [l]tic ^{179 78}	7

3

T	fleet, w ²¹⁴ (h)o wer ¹⁵² e left behin ¹⁷⁵ d at [V ¹⁵² igo in ord ⁴⁹ er]	5
H	fleet, wh ²³⁰ (o)wer ¹⁸⁰ e)left behin ²⁴⁰ d at Vigo in ⁴¹⁰ (orde)r]	4
S	[²⁸⁰ fleet, wh ³²³ o] w ¹⁷⁵ (er)e left behind [at ²¹⁸] [V ²¹⁸ igo i ³¹⁵ n order]	7
F	[⁴³⁵ fleet, wh ³⁰⁵ o] w ²⁷⁰ ere le ²⁵⁸ ft behin ¹⁸⁸ d [at ²⁵²] [V ³⁶⁴ igo] in o ³⁷⁶ rd	8
M	[³⁵⁶] fleet ¹⁵² , who wer ¹⁶⁸ e left b ¹⁶⁰ ehin ¹²⁰ d at [V ¹⁷⁶ igo in order ²⁹⁶]	9

4

T	that t ¹⁸⁵ (h)ey migh ¹⁴⁶ t testi ¹¹⁷ fy, and wh ¹⁰⁷ o were ⁹⁷ on]	5
H	that th ¹⁹⁰ e(y)migh ²⁴⁰ t testify, and who were ²⁴⁰ (on] ¹³⁰	4
S	[²²⁵ (th)at the ³³³ y]migh ¹³⁵ t testify, and who ¹⁹⁸ [w ²²⁵ ere on] ²⁴³] ¹⁴⁴	7
F	t ⁴⁴⁶ [hat t)hey [m ²⁴⁵ ight t]estify, and wh ²⁹⁴ o w ⁴⁴⁷ ere on ¹⁸⁸	5
M	[²⁶⁴ that t]hey migh ¹⁰⁴ t tes ¹¹² tify, a(n) ¹³⁶ d who were ¹²⁸ (o]n ¹⁴⁴] ¹³⁶	7

5

T	their ²⁰⁰ way to [St. Pet ¹⁶⁰ ersburg, to re ²¹⁰ main in]	4
H	thei ¹²⁰ r(way ²²⁰) to St. Petersbur ²⁶⁰ [g, to re)mai ¹⁶⁰ (n) in]	4
S	thei ^b r[way ⁴⁰⁷) to St. ^a Petersb]urg, to re main in ⁷⁴]	5
F	[⁵⁵² (the)ir way ⁷⁰⁵] to St. P ²⁰⁰ etersburg, to r ²⁸² (em)ain ³¹⁷ in ²⁰⁰	6
M	[^{*311} (the)ir way ¹¹⁴ to St. P ¹³⁹ etersburg, to rema ^c (in) in ⁹⁰] ^{*155}] ^d] ¹¹⁴] ^f] ¹⁰⁶	7

6

T	¹⁷⁰ 1Par is.
H	[²⁷⁰ Paris).
S	[²¹² Paris.)
F	[⁴³² Paris.)
M	[²⁵⁴ Par)is.

7

T	¹⁷⁰ 1Ad miral Kaz ¹⁶⁰ nakoff, a member ¹⁷⁰ of the]	3
H	²⁷⁰ 1Ad mir[al Kazna ¹⁸⁰ (ko)ff, ([a] m]emb ³⁰⁰ er of the ²²⁰] ¹⁶⁰	6
S	^a Admir ²¹² al [Katnakoff, a mem ²⁴⁰ (b)er ^c of th ¹⁹⁴ e] ^f] ⁵⁹⁷] ^d] ¹²⁰] ^e] ¹²⁹	6
F	⁴³² Adm)i ⁴⁸² (ra)] Kazna ⁷⁷⁵ (k)off, a mem ¹⁸⁸ ber ³⁸⁸ of the]	5
M	[²⁵⁴] Adm ^a (ir)al ⁴¹⁸]Kaznakoff, a mem ¹²³ ber ^c of the ^e] ^d] ³¹¹] ¹³⁹	6

¹ 'Paris' of line 6 was read with line 7 by all subjects. The location of the fixations and their durations are marked in both 'Paris' and 'Admiral', it not being possible to determine how the eye divided its time between the two words.

8

T	Admiral ¹⁵⁰ ty Cou ¹²⁰ n ¹⁶⁰ cil, who was ²²⁰ appointed	4
H	²⁷⁰ Admiral ^b ty Cou ¹⁹⁰ ncil, [(who) was ³⁰⁰ appointed ²⁰⁰]	6
S	Admir ³⁴² (alt)ty Council,)who was ³³³ appointed ²³¹	4
F	[A]dmiral ⁴⁵⁸ ty Cou ³⁶⁴ ncil, wh ²¹¹ o wa ¹⁸⁸ (s) ap ²⁴⁷ [p]ointed	5
M	Admir ²⁷⁰ al ¹⁸⁹ ty Cou ¹⁹⁶ ncil, who ¹¹⁴ wa ¹⁰⁶ s ap ²⁴⁶ pointed	6

9

T	yesterda ¹⁹⁰ (y) upon the internat ¹⁷⁰ ion ¹¹⁰ (a)l com-	3
H	yeste ²⁴⁰ (rda)y up ²⁴⁰ (on) the in ²⁴⁰ tern ¹³⁰ ati ¹³⁰ (o)nal com-	4
S	yest ²⁵⁸ (er)day upon (th)e in ⁴⁵² (te)national com ²⁵⁵ (-)	4

10

T	mission [w]hich is to inquire in ²⁸⁰ to the [Nort]h ¹⁶⁰	4
H	mission [whic]h is ²⁰⁰ to inqu ¹⁸⁰ [ir]e in ¹⁶⁰ [to] the North ²⁴⁰	4
S	[mission whic]h is to i ²²⁸ nqu ¹⁸⁰ ire ⁸⁷⁵ int ¹⁴² (o) the [N]orth ³⁴²	6

11

T	[Sea af]fair, started ¹⁷⁰ [for] Paris toda ¹³⁰ y. His ¹²⁰	4
H	Sea affair, ²⁴⁰ []star ¹⁷⁰ ted for Par ²²⁰ is to-da ²²⁰ [y.]His	4

12

T	appoint ¹⁷⁰ (me)nt is welc ¹⁶⁰ omed as an ¹¹⁰ [i]ndication ¹²⁰	4
H	[appoi]ntment is ²⁸⁰ i ²⁴⁰ s welc ²⁸⁰ (ome)d [as) an indi ²¹⁰ cation ¹²⁰	5

13

T	[that t]here will b ¹⁷⁰ e a thro ¹⁰⁰ (u)g(h) search for ¹⁴⁰ the ¹³⁰	4
H	[that] ther ²²⁰ (e) wil ¹³⁰ [l be a th)roug ²⁰⁰ (h) sear ²²⁰ (ch) for the ²⁴⁰	5

14

T	facts of [th]e case. ²⁰⁰ []The Ad ¹²⁰ [m]iral won ¹⁶⁰ []golden ¹⁰⁰	4
H	³¹⁰ [fac]ts of the case. T ²⁰⁰ (he) Ad ¹⁵⁰ [m]iral won ¹⁶⁰ golden	4

² Lines 7 and 8 were read with one horizontal movement by Subject H.

15

T	o ¹⁸⁰ [pin]ions among the members ¹⁹⁰ [o]f th ¹²⁰ e con-	3
H	o ²⁴⁰ pinions amo ²⁰⁰ ng the [members) o ²¹⁰ (f] t ¹⁷⁰ h ⁸⁰ e con-	5

16

T	ve ¹⁹⁰ [ntion held in ¹⁴⁰ Washington in 1889 t ¹⁸⁰ (o)for-	3
H	ventio ³⁸⁰ he ²⁰⁰ (ld] in Washinto ¹⁸⁰ [n in 18)8(9] to for-	3

17

T	mulate rules of ¹²⁰ the road for ¹³⁰ [t]he se ¹⁶⁰ (a). He	3
H	²⁹⁰ mulate rules ¹⁹⁰ [of)the road fo ¹⁹⁰ r the sea. He	3

18

T	was Rus ¹⁹⁰ [sia)'s repre ¹⁶⁰ sentative ther ¹⁴⁰ e. He w ²⁰⁰ ill	4
---	--	---

19

T	prepare the ²⁰⁰ Russian ¹¹⁰ case and will ¹⁰⁰ cite a ¹⁰⁰ (n)	4
---	---	---

20

T	incident ¹⁹⁰ [)reported in t ¹⁴⁰ he Naval A ²⁶⁰ (nn)u ²¹⁰ (a] of	4
---	---	---

21

T	1903. ¹⁸⁰ [In) that cas ¹³⁰ e the ¹⁶⁰ British cruiser	
---	---	--

CHART II

SUMMARY.

	Av. No.	Av. Duration.	M.	A. D.
T	3.8	160.8	152	36.8
H	3.9	216	220	50.
S	5.5	255	238	87.
F	5.4	401.9	240.7	163.7
M	7	196	160	79.9

CHARTS III-VI

READINGS BY FOUR SUBJECTS OF PASSAGE FROM SCIENTIFIC ARTICLE

CHART III, No. 28 T

Ev³⁴⁰[olutio]nary study and ²⁶⁰(t)hought h⁰¹²ave been h²¹⁰(in)dere¹⁶⁰d by the ¹⁵⁰confu- 6
 sio²⁶⁰n of tw¹⁴⁰o unrelat¹⁵⁰ed biological| phenomena, ¹¹⁰(1) evolution¹⁴⁰ary pr¹¹⁰gress 6
 or vital¹⁷⁰ m¹⁶⁰otion, and (2) t¹⁰⁰h¹⁶⁰e origina¹⁶⁰(ti)on or multipl²³⁰[ic]ation| of species. 6
 The 'origin'¹⁵⁰ of a spec¹⁴⁰ies) is not m¹⁵⁰ore evoluti¹⁶⁰onary than ¹⁵⁰any ¹⁶⁰(o)th¹⁰⁰e)r stage 9
 [in] its history. The²¹⁰ causes of the ¹⁵⁰su¹⁴⁰bdiv¹⁶⁰(i)sion of spec¹⁵⁰ies ar¹⁴⁰e not causes 7
 [o]f vital motion; the t²¹⁰(wo) processes| are quite¹³⁰ distinct. [Th]e separation 5
 of| tw¹⁶⁰o spec¹²⁰ies is not ³⁸⁰[a] focus o¹²⁰f the evoluti¹³⁰onary problem;| it is a mere 6
 |incident of ⁸⁰[de]²⁰⁰velop²⁰⁰(mental) history. 4
 b a c

No. of fixations, 49. Average duration, 169.41. A. D. 53.01 (Median, 150).

CHART IV, No. 14 A H

[Evo(lu)tiona²⁹¹ry] study an¹⁴⁸d tho¹⁷⁴ught [hav]e been²²⁷ [hin]de¹⁷⁴red by the ¹⁴⁸[o]n²¹²ffu- 7
 b₁ b₂ a c
 sio³¹⁸n of tw¹⁶⁰(²²⁷unr[el]at¹⁷⁴ed biologica²⁴⁹l p)henomena, (1), e²²⁷(vol)uio¹⁷⁴na²²⁷ry pr²²⁷(o)gress 6
 a₁ a₂
 or v³⁹⁴ital) motion, and (2) th²⁰⁶e or²⁷⁵(igi)nat²¹⁶ion) or multiplica¹⁶⁷(tion) of specie¹⁶⁷(s.) 5
 b₁ b₂
 The 'ori³⁸³gin' of) a species is not mo³⁹⁴re evolutionar¹⁶⁷y th¹⁵⁶an any o⁹¹the¹⁶⁷r st⁹¹age 5
 in its³⁵⁵ [his]tory. The c⁴²⁹auses o²⁸⁰f the subdivisio³⁰²n of) spec²⁶⁸ies are no²⁶⁸t caus²⁶⁸es 5
 of vital³⁶² [m]otion; the two ²¹⁸[pro]cesses are¹⁷⁹ []quite distinct.¹⁷³ []The separ²¹²ation 5
 of two spec²⁵⁶ie)s is not a fo²³⁹cus o¹⁷⁶f the evolutionary probl¹⁷⁶em; it) is a |mere 4
 |incide⁵¹⁰nt ²³⁷[of d]ev²³⁷(elop²³⁷[m]ental) histor²³⁷y. 4
 b a b a
 |Se⁵¹⁰gre²³⁷(gation) is t²⁰³(he) principle ¹³⁹(or active ²⁰³[cau]se of the multipl²⁹⁵[ic]ation 6
 b a b a
 species, [but) the natu³²⁴re a)nd cause¹⁶⁵s of evol²¹²u(tio)nary pr²²⁰ogre¹⁶⁵ss are not ³⁹⁵to 6
 b a b a

¹These two lines are read together, the eyes alternating somewhat between the two during the first half of the line. The first three pauses are therefore marked in each line. In the page read each pause comes under the other.

CHART V, No. 43 B S

200	120	300	200	200	160	160	140	100	9
Evolutionary s(tudy and t thought have be en hind ered b y the confus-									
320	180	140	140	190	190	620	170	8	
si(on o)f two unre lated biolo gical phe nomena, (1) evo(lu)tionary[]progress									
b	a	c							
340	120	200	230	1120	230			6	
[or vi]tal m otion, and (2) t he or iginat ion or [mul]tiple[]of [s]pecies.									
			e ¹	e ²					
80	160	200	220	280	700	120	7		
The 'or igin' of a species is not more evolution ary [than any) other s tage									
b	a								
200	120	200	160	200	160	730	7		
in its history. The ca uses of the subdi vision of sp ecies are not [causes)									
b	a								

Average pause, 253.51; A. D., 102.7; Median, 200.

CHART VI, No. 74 A St

250	246	205	164	160	5
Evolution[ary) study an d thought hav e been hindered by the confu-					
164	184	283	275	131	5
sio[n of two unrelat ed biological phen omena, (1) evolu[tio]nary progr[ess					
312	221	160	246	183	5
[or vita]l motion, and (2) t he originat ion or multipl ication of species .					
131	144	152	238	94	283
[T]he 'origin' of[]a species is not more[evolution ary th an any other stag[e)					6
b	a				
291	291	230	217	123	5
in[its) history. The ca uses) of the subdivisi on of species a[re) not causes					
135	197	353	152	115	86
of[vi]tal) motion; the two[p]rocesses are quite [di]st[inct]. The separa tion					7
b	a		d	.	
324	205	225	225	180	5
of two species is not a focus of the ev olutionar[y)problem; it is [a)mere					
176	217				4
[)inc ident of[dev]elopmental history.					
a	d	c	b		

The following observations may be made of the charts in general:

The first and last fixations generally fall within the edges of the line, i. e., at a little distance from its beginning and end. This is true in less degree for some individuals than for others, and is, secondly, dependent upon the character of the end words in the line.

The exact point that is fixated may be in any part of the words, or in the spacing between them. It does not fall predominately in the first part of words, nor does it occur more frequently in the first part of the sentence than in the last, and apparently pays little attention to many of the laws of apperception, or the rules of the rhetorician.

But, as has already been remarked, the exact point of fixation may in itself be of little significance, and may vary within certain limits without affecting the process of perception. It is important mainly as denoting that the attention is 'distributed' immediately about it. In other words, the process of assimilation and apperception are immediately concerned with that part of the field of perception which lies about the point of fixation. There are, however, certain fairly well differentiated features which decide where the eye is to stop, and it will be the object of the next section to point out and discuss these.

Why Does the Eye Stop at the Places Indicated in the Charts?

The purpose of the repeated readings of the same passage by the various subjects is to give a wider basis for comparison and analysis of the evidently complex conditions which direct the peculiar alternation of movements and pauses of the eye. In the case of successive readings by one subject, if the apperceptive and other conditions which govern the movements and pauses are at all constant, it is perhaps natural to suppose that they would tend to act much in the same way when a passage is re-read, and in the later reading, therefore, the fixation pauses would be formed in about the same places as before. The familiarity or practice secured in the first reading might supposedly act in one of two ways. The eye might through practice come to follow a very definite and comparatively invariable method of advance, with marked decrease in the time taken for the pause; or, more probably, the knowledge and remembrance of what was to follow would cause both fewer and shorter fixation pauses. The latter effect might be minimized, if the matter read were such as to be little likely to be long remembered, and secondly if several weeks' time were allowed to pass between the readings. The first five lines of each reading are taken for comparison. The second reading was, as stated, made a month after the first. The second, third and fourth readings were made one after the other in the same hour. The smaller number of pauses in the second reading shows that some general familiarity with the word sequence was carried over from the first reading. There is also a somewhat further decrease in the succeeding readings. The pauses which have been dropped out or whose work is done in the later readings by other pauses may be taken to represent the least essential parts of the line. Where the location of the fixations remain practically the same throughout all or a majority of the readings, we may expect to find there the parts of the line most necessary for recognition, and the factors which condition most effectively the places where the eye stops.

In the reading in the case of different persons, there are also many factors which would seem to work for uniformity. Although naturally considerable apperceptive differences are to be expected, a great deal of our reading and training, through school and college, etc., has been similar; the fund of 'associative expectancy' in the sequence of words and phrases must be fairly common, at least in the daily reading of the daily newspaper and magazine, and besides the many stereotyped similarities of writing, there are also certain natural and rather arbitrary signs in the forms of printing which the eye follows. If the more or less artificial matters of arrangement of type, of spacing, punctuation, capitalization, length of line, etc., have an appreciable influence, it would undoubtedly be to make the alternation of movements and pauses more uniform. The similarities in this respect, which can be traced in the reading of different persons, will strengthen the evidence for the working of definite conditioning factors.

What, then, are the facts which hold good throughout? The first which strikes the attention is that the short connective and non-substantive words, the prepositional phrases and relative clauses, make the greatest demands upon perception. This is best evidenced by the fact that they necessitate the eye's coming out quite to the edge of the lines. A comparison of all the readings in Charts I to VI shows that the phrases 'in order that' (third line), 'who were on' (fourth line), 'to remain in' (fifth line), etc., increase the angular excursion of the eye nearly to its maximum for that line. In contrast, compare the distance of the last fixation in the first, second, and seventh lines from the edge; the words 'admiralty,' 'Baltic,' 'appointed,' etc., extend the space between the fixations. So also at the beginning of the line, for example in Chart II, subject T, compare the distance of the first fixation from the end in 'telegraphed' (line 2), 'admiralty' (line 7), 'yesterday' (line 8), with that in the fourth line 'that they might,' etc., or the twelfth line 'that there will be,' etc. That these phrases are most important elements for fixation is further made clear in the repeated readings of Chart I. In line four, the eye passes with but a single break from the phrase 'that they might' directly to the word 'and,' but makes two fixations in the phrase 'who were on.' So the preposition 'in' (line 5) in the phrase 'to remain in,' receives surprising attention for so small a word when it is seen that all of the first part of the line 'their way to St. Petersburg' is grasped in a single fixation. The decrease in pauses in the repeated readings is made most easily in the lines having a few long substantive words, with greater difficulty in those lines which are filled with short worded clauses and relative and conjunctive

phrases. Compare the groups of lines three and four with those of one and two. This point is further illustrated by the comparative lengths of the space between any two fixations in other parts of the line. For example, again, notice, in Chart II, subjects T and H, the proximity and number of the pauses to the phrases 'into the north' (ninth line), 'for the facts' (end of twelfth line), 'of the case' (thirteenth line), 'to formulate' (fifteenth line), 'of the road' and 'for the sea' (sixteenth line), 'in the naval' (nineteenth line), 'In that case' (twentieth line). And contrast, again, the greater speed of perception in the words 'has telegraphed' (line 2), 'testify' (line 4), 'international' (line 8), (except in the reading of H), 'golden opinion among the members' (lines 13 and 14), 'in Washington' (line 16). These examples are sufficient to show that the relative pronouns, prepositions, conjunctions and the auxiliary verbs are apt to divide the process of apperception into narrower units than in the case of nouns and substantive words, adjectives, etc. The explanation is doubtless that these words are not associated in one phrase more regularly than in another, they cannot be fused into a larger apperceptive unit, as the syllables into a word form, or 'phrase whole'; but each stands by itself, and must be so perceived.

A similar frequency of fixation is to be noted about the date 'Nov. 2' in the first line of Chart I. The reason is evident. The numeral and abbreviation also stand for separate units, must be perceived separately, and cannot be easily made a part of some constant unit. The experiments with lines and groups of numerals have already emphasized this fact. A similar result was true in the reading of lines of letters. It would, of course, naturally have been much harder to group the letters. The principle involved is probably the explanation of the small units of perception in the cases of the prepositions and conjunctions, etc. Since they occur now with one word and now with another, they cannot without danger of error be fused into larger wholes, and, for that reason, they must, except where the context gives the connection, be separately perceived. When the noun or other word implies in itself the nature of the following preposition, as in 'The causes of the subdivision of species' (Charts III-VI) the latter becomes an integral part of the unit of perception. With the word 'cause' we expect to have 'the cause of' or 'for.' The sort of conjunctive word, etc., may often be similarly supplied.

The nouns and adjectives and verbs which have been cited are in contrast recognized with a wider grasp of perception and as wholes. Such words as (Chart II) 'telegraphed,' 'international,' 'Washington,' 'representative,' are perceived at a single fixation.

The question may arise as to why there is more than a single fixation in some of these words, as, for example, is the case in the word 'international' in Chart II, line 8, subject T, 'evolutionary,' Charts III and V, line 1, 'subdivision,' Chart III, line 5, and 'developmental,' line 8. In the first place, it will be noted that these cases are very much the exception, especially for the rapid readers or those who have usually a wider span of attention. Ordinarily these words are perceived as units, the fixation pause occurring either in or near them. Charts III and VI, having a larger number of nouns and substantive words, give the best opportunity for making this comparison. It will be noted here that each one of the long words is perceived by a single fixation. Such a phrase as 'biological phenomena' (Chart III, line 2), which is perceived with one fixation, is nearly equal in extent or number of letters to the working range of the field of perception as determined by the fall exposure apparatus. This is, therefore, the rule. The exceptions in which a second fixation is made need probably no further explanation than that in these cases some misconception of the thought or incomplete perception made it necessary to fixate the word again. As will be further noted in the case of reading aloud, the eye often follows along as the syllables of a word are successively assimilated. This is particularly true of some slow readers who perhaps depend more on the motor articulatory system in silent reading. Compare, for example, the word eq[ui]va|le|nt in line 2 of Chart X (a slow reader.) In the case of the slow reader the unit is often, therefore, the syllable instead of the whole word.

Not infrequently the apperception of the individual or his memory for words and phrases allows of an exceptionally large 'jump' between fixation pauses. The word 'St. Petersburg,' Chart I, causes one or two fixations in the first line, whereas in the fifth line it lies mainly in the field of indirect vision. In another passage (Chart VII, a teacher of 'Education') the long phrase 'methods and principles of teaching' occurs in the fifth and ninth lines. In the fifth line it was read with the usual number of fixations, in the ninth with one fixation. It is probably this skipping of familiar or oft recurring phrases as much as anything which gives readers the impression that they are reading but one or two words to the line. In view of these many possible individual apperceptive differences, the cues of context and familiarity with subject matter, it is perhaps surprising that the results of the experiments have even the consistency found. For this reason the slower readers perhaps best illustrate the above noted facts in regard to the im-

importance for recognition of the various parts of the sentence. (Compare for example Chart X).¹

It is then not to be expected that the necessity for more careful fixation of the 'transitive' parts of speech will appear equally in all subjects or passages. The general associative word expectancy will cause phrases to be passed over that might in the case of another reader need more careful attention.

CHARTS VII-XI

READINGS OF FOUR SUBJECTS OF 'A LICENSE FOR PROMOTION,' ETC.

CHART VII, I A H

II. [A] li[ce]nse for pro[m]otion may [be is)ued [to] the ho[lder) of[a] 7
 teach[er's] licens[e]No. 1 who has[ha]d experien[ce] rated as[equ]ival[ent] to 6
 t[hr]ee [y]ears of New Yo[rk] city pu[b]lic school t[eaching] ((i)nclu[ding] [o]ne 9
 ye[ar] in [the c[ity] of Ne[w]York); [w]ho passes a[n] examin[ation] |in the 8
 p[ri]nciples a[n]d met[h]ods of [teaching, or] in lieu [the]reof prod[uces] evi- 7
 denc[e] of[ha]v[ing] succ[ess]fully pur[s]ued, s[ince] b[e]ginn[ing] h[is] wor[k] as a 10
 teach[er], in some [re]cognized [in]stitutio[n] of learn[ing], one or| two satis- 7
 fact[or]y c[ourses] of s[tu]dy invo[lving] i[n] all no[t]less than [sixty] hours' 7
 at[te]nd[anc]e, in pri[n]ciples and methods of te[ach]ing; |and who passes 5
 an| aca[demic] ex[am]inatio[n] in one| of several groups of| subjects as 7
 an[nou]nced [by] the Boar[d] of Ex[am]iners.—)A graduat[ing] class |license 8
 [may]be issue[d] to the [ho]lder of [a promo[ti]on] licen[se] who ha[s] taught for 7
 a p[er]iod r[at]ed as equi[valent] to five ye[a]rs of| New York city public 5

CHART VIII, 13 A H

[A]lice[n]se for pro[m]otion may [be] issued to [the h[old]er of] a 6
 []teacher[']s] license No. 1) who ha[s])had ex[per]ience rat[ed] as eq[ui]valent to| 8
 thre[e] [y]ears of New York c[ity] public sc[h]ool teach[ing] '(in)clud[ing] one 5
 ye[ar] in the city of New York;)' w[ho] passes) an exam[in]ation[] [in] the 6
 [pr]inciples[]and methods| of teaching, or in [lie]u [ther]eof p[ro]duces[]e]vi- 7
 dence of ha[v]ing)succ[ess]fully pursu[ed], s[ince] [be]ginn[ing] his w[or]k as)a 4
 teach[er],)in some r[ec]ognized [in]stitutio[n] of [lear]ning, one or[]two[]satis- 6
 fact[or]y c[ourses] of []study involv[ing] in all n[ot] less t[han] sixty hours 5
 attendanc[e], |in p[ri]nciples and met[h]ods of teach[ing] [and] w[ho] passes 7

¹ Especially '(w)ho [h]as | ha[d],' line 2, with 'experi[en]ce rated [a]s; who [p]ass[e]s a[n],' line 4, and 'i[n] lieu th[er]eof[,' line 5, with 'm[eth]ods of teach[ing] and succ[ess]fully.'

² These parentheses belong in text.

Summary of Chart VIII

N., 54. Av., 211.6. A. D., 68.7. (M., 186.)

CHART IX, 41 B S

³⁸⁶ [A license f^or promoti^on ma^y] be issue^d) to the h^older of [a 7

³⁴⁸ t^heac^her's licen^se No. 1 wh^o has ha^d experien^ce rated [as equi^valent] to 9

²⁸⁸ [th^ree years of [New Yor^k city public [school teac^hing¹ (inc^ludin^g) one 8

³⁹⁰ [y]ear in the city of Ne^w York¹; who pa^ssed an examⁱnation in t^he 6

²⁴⁶ p^rinciples and [methods of t^eaching, or in [lieu thereof] prod^uces) evi- 6

³⁹⁰ denc^e [of having s^uccessfully [pur^sued, sin^ce beginnⁱng his w^ork) as a] 7

⁷² [teac^her, in [some recognⁱzed institutⁱo)n of learning], one or t^wo satⁱs- 8

²⁴⁸ fa^ctory) c^ourses o^f stud^y involvⁱng iⁿ all not less than sixty hours 6

57

N., 57. Av., 200.7. M., 186. A. D., 61.02.

¹ These parentheses belong in text.

² Incomplete line.

CHART X, 49 B F

⁵⁴¹ A [l]icence for [p]romotion [may be] issue^d to [the] holde^r of [a 10

⁵⁴⁸ teacher's [l]icens^e) No. 1 [w]ho [h]as [ha^d] experi^en^ce rated [a]s equi^valent to 11

¹⁸² [th^ree] ye^ars) of [N]ew York [ci^ty public [school] t^eaching (in[cl]udin^g) one 10

³⁰² [e]ar) iⁿ the ci^ty) of Ne^w York); who [p]ass^es a[n] examinatⁱo)n) in the 8

³⁶⁵ p^rin[ci]ples and m[eth]ods of teachⁱng, or iⁿ [lieu th^reof] produ^ces e^vi- 10

³³³ [e]nce [of] havⁱng [succe^ssfully] purs^ued, sin^ce beginnⁱng his work as a 3

52

N., 52. Av., 295.3. M., 277.2. A. D., 91.3.

CHART XI, 72 B S

	407	245	279	309	358		
	II. A	license fo r	promotion ma y	be issued t[o	[the ho]lder of a		
				e1	e2		
240	220		323	304	284	191	
[]	[]	teacher's license	No. 1 who [ha]s had experience	rated as (equi	valent to		
338		338	176	294	206	260	
[]		three years of Ne w	York city pub lic school t eaching ((in cluding one				
278		278	216	115	240	216	206
y ear in the city of New	York); who pa ss[es a)n	exa mination in the					
a	b	c	d	e	f		
394		375	293	240	336		
[]		princip)les and me[thod]s of teaching,	or in lieu there of produces [evi-]				
240		254	317	403	307		
d[en]ce of having s uccessfully pursue d, since begi nning his work[as a)							
301	202	244	324	240	211	132	
tea cher, in some rec ognized in stitution of [learnin]g, one or [tw]o satis							
b	a	c					
296	550	348	221	273	188		
factory c o[urses o]f study involv[ing] in all not[less th]an sixty ho urs							
188	249	282	132				
[]	[]	atten)dance, in[]	princi]ples and meth ods of teaching; and who passes				
b	a						

No. of fixations, 48. Av. duration, 275.9σ, A. D. 67.2. Median, 257.0σ.

The requirements of apperception or assimilation determine, as has been seen in the comparison of nouns and phrases, the general extent and position of the apperceptive unit. But, as has been doubtless noted, it is apparently immaterial in most cases whether the eye stops at the center or towards the end of the words. Is, then, the place of fixation within these limits determined by chance? The experiments of the lines of numerals and letters shows that the eye is dependent, through custom, on the more or less artificial spacing and grouping of words, and it is by causes of this sort that the fixation is governed within the limits assigned by apperception. In the first line of Chart I, for instance, the pause is made in the spacing after the date and numerals, and before the dash. The marks of punctuation have a similar effect. Note, for instance, the last pause in line 10, Charts II and III, the second in line 13, Chart III, the first in line 20, or the sixth pause in line seven, Chart VII.

In the case of some readers, the marks of punctuation, and the like, prove greater 'obstacles' to the eye's movement than in others. They often cause a break in the movement where undoubtedly there would be none made for purely perceptive reasons. Bracketing, quotation marks, and particularly any peculiarity in printing, may do this. For instance, in pages of proof reading, where the pauses are, as in reading aloud, much more frequent and closer together, a false alignment, etc., will often 'halt' the eye. The proof reader is on the watch for these inaccuracies; but the effect is often

similar in the usual reading, although, of course, the mind is not ordinarily conscious of it any more than it is of the fixations in general.

Other factors which may govern fixation are the capital and 'domineering' letters. These latter are, in general, the letters most easily perceived,¹ mainly "those letters which project above the body of the word and the additional middle sized letters x and z."² Examples of the latter are 'admiralty,' Chart II, line 1, 'officers,' line 2, 'Kaznahoff,' Charts I and II, 'Baltic,' Chart I, line 2, and 'Paris,' Chart I, subjects T and S, 'Vigo,' (line 3), Chart II, line 3, etc. There are many of the capital and domineering letters in each line, and they are naturally not all equally operative; but, when the general distance of the interfixation movements is once determined, they, with the other causes mentioned, may sometimes govern the location within this area. They furnish, possibly, a better form of peripheral stimulation than the middle sized letters, i. e., they 'catch the eye' more readily. They may, in other words, be supposed to condition the word complex—the 'Gesamtbild'—to a greater extent than the other letters of a word.³

The influence of some or all of these factors when in another line than the one being read is also to be noted. They often distract the attention, but they are undoubtedly also of service in determining the location of the fixation pauses in the second line. There is plenty of evidence to show that when the eye is reading in one line, the mind is vaguely conscious of matter lying in the succeeding lines. For instance, the long distance of the first fixation in line 2, Chart II, from the edge of the page, in 'has telegraphed' is doubtless due to the fact that this word was in the 'margin of consciousness,' while the word 'St. Petersburg,' just above it, was being read. If the words in the line below have absolutely nothing or little to do with the sense of the line being read, this view is often more of a hinderance than a help. In the case cited, however, the associative expectation was 'ready' for such a word as 'telegraphed' at the beginning of a newspaper column. The reading together of lines six and seven of Chart II is doubtless, also, in a similar way due to the initial similarity of the lines, i. e., 'admiral,' in line six, 'admiralty,' in line seven.

To answer, then, the question as to what determines the location of the fixation pauses, it is first and principally the unit of apperception. This may be small in extent, as in numerals, abbreviations, conjunctive phrases, etc.—in a word, when several

¹ See Cattell on the Legibility of Letters, in articles referred to above.

² Cf. above Chap.

³ The statement of the possible effect of the domineering and capital letters is offered somewhat tentatively.

small words cannot be regularly associated together into a single unchanging group, or large in the cases of long words and very familiar phrases. The location of the fixation within these limits may depend in part on the more or less artificial peculiarities of spacing, punctuation, and the forms of letters in printing. To these latter causes must also be added the fact earlier noted, that within certain limits the eye can regulate its positions, in order to maintain its so-called 'short-lived motor habits.'

§ 2. *Proof-reading, Effect of Articulation and of Near and Far Accommodation, etc.*

The effect of various other factors, as that of near and far accommodation, the reading of foreign languages, etc., upon the number and duration of the fixation pauses has already been referred to.

The significance of the experiments in these cases is in at least one particular the same, i. e., it is not the mere extent of words which can be easily seen which determines the span of attention or the number of fixation pauses. Although there is more of the line in the field of clearest vision in far accommodation, the number of pauses remains about constant. The results of readings of the same page by one subject are shown in Charts XII and XIII. The page was placed in the first case (No. 17) at approximately 15 centimeters from the cornea of the eye, and in the second case (No. 18) at approximately 40 centimeters from the eye.

The effect of reading of a foreign language is to increase both the number and duration of the pauses. The same result may be illustrated in proof reading. (Cf. Plate V, 5, 6, and Chart XIV.) The page read is from a biographical directory. Names have been altered but their general form and length have not been changed.

The effect of reading a passage aloud is also somewhat similar. Naturally greater attention must often be given to the parts of a word in pronouncing it, with the result that the word innervation is more often divided. The time per fixation as well as the number of fixations may be increased. It is somewhat a matter of individual difference. In Chart XV B of Record 42 A (subject S), even fewer fixations are made in the first few lines than in 41 A, which was the silent reading and immediately preceded it. The time spent per line in fixation is, however, increased by 461σ , for example, in the first line. The case is somewhat reversed in Record 29, Chart XV A. This passage was read aloud immediately after reading it silently (cf. No. 28, Chart XV A). The number and time would have been somewhat increased had the reading aloud

preceded the silent reading. As it is, it takes 1,474 σ longer to read the whole passage.

Fifty pauses are made in the silent reading (No. 28), 68 in the reading aloud (No. 29). The *average time* of the pauses in the latter case (No. 29) is shorter, 144.1 σ (A. D. 47.6) as compared with 169.4 σ (A. D. 53). Since the total time is longer, this shows that in reading aloud the time is more equally distributed (see also chart) in all parts of the line. It shows that the freer movement of the attention 'wave' is repressed by the slow process of articulation. In reading aloud as in reading a foreign language, the attention must be given more often than ordinarily to parts of words and syllables. These facts may also be noted in even the seventh reading of a passage by subject H. This passage (33 A), which was read aloud, may be compared with any of the earlier readings above.

It is interesting to note in No. 29 the similarly large percentage of refixations at the beginning of the line, which was much in evidence in the first reading (No. 28). It further supports the hypothesis that it is a matter of habitual reaction for this subject (T). Since it is not possible to return with any certainty to the beginning of this long line, the movement regularly falls short, and a regressive movement is made if necessary; in lines two, three, and seven it was not necessary, in the other lines regressive movements are made (cf. above). The charts of (1) reading by near and far accommodation, (2) of proof reading, and (3) of reading aloud follow (Charts XII-XVI). See also Plate V, Nos. 5, 6, 7, and 8.

CHART XII

READING AT NEAR ACCOMMODATION

No. 17

Summary

[]E|volutio|nary stu|dy a)nd thought h|ave bee[n] hinder|ed by |the co|nfu- 9
 on of t|wo un|related biologic|al phenomen|a, ¹(1) ev|olutio[nar]y prog|ress 8
 [v]ital motion and ¹(2)[th]e or|iginati|on or[multi]plicati[o]n of sp[ecies.] 6
 [he 'o]rigin' of[a] species is not mo|re evolution|ary than any other stage 3
 its history.

¹These parentheses belong in text.

CHART XIII

FAR ACCOMMODATION

No. 18

Evolutionary study and though have been hindered by the confusion of two unrelated biological phenomena, ¹(1) evolutionary progress or vital motion, and ²(2) (the origin (ation or multiplication of species.) in its history. The causes of the subdivision of species are not causes of vital motion; the two processes are quite distinct. The separation of two species is not a focus (of the evolutionary problem; it is a mere incident of developmental history.

¹ These parenthesis about the numerals belong in text.

CHART XIV

No. 34 B

¹⁶⁵ Mento[r,]¹⁰⁴ P[ro]f. ¹⁶⁵ Albe[rt] ¹¹⁶ M(¹¹⁵ cDona[ld]⁴²⁴)¹, ³⁰⁵ E. ³⁶³ S[oa]p- 9
²⁶⁸ [ston]e St., ¹⁵⁴ Lex[ingto]n, Ct. ³¹³ [Bi[ology].] ⁵⁴⁷ X[enia], O, 7
⁴³¹ [Aug]. 5, 45. ⁴⁶⁰] A.B, ³¹³ Pri[n]ceton, ¹⁸⁹ [89,] A.[M,] ¹⁷¹ 91, ²⁹¹ [fell]ow. 7
⁴³⁷ 91-92; ²¹² M[unic]h, ¹⁸³ 92[93.] ⁴⁴⁸ Pr[inc]ipal, ³⁴² High ²⁰⁶ Sch, ²³⁶ 7
³⁸⁹ Xen[ia, O,] ¹³⁰ 9[0-91;] ⁴⁰⁷ pro[.f.] ⁴⁹⁰ zool. ³⁴² and ³⁷² ge[ol,] ³⁷² Tilt[on], 6
⁴⁸⁴ 93(-95;] ²⁶⁴ biol, ³¹³ [Ct]. ²⁰⁷ st[ate], ¹⁴² 95. ²³⁶ F.[A.A;] ²⁰⁶ Bio[.l.] ³⁸⁹ Soc. 9
³⁷² Ge[ology] ¹⁰⁶ of(⁹⁴ p[et]roleums 9
^a No. of fixations, ^c 45. ^b

¹ These parentheses belong in text.

² Note overestimation due doubtless to extension and heavy type of first line.

CHART XV A

READING ALOUD

No. 29

Subject T

Evolut[io]n[a]ry study an[d] (t)hought h[a]ve been [h]indered [b]y the co[n]fu-	64 b	102 e	112 a	study an[d] f	441 c	112 c	h[ought] h[a]ve been d g	22 d	160 g	96 h	96 i	168 j	10
tion of t[wo] un[r]elated biolo[gical] pheno[m]ena, ¹ (1) evoluti[on]ary pro[gress]	104	128	88	136	40	216	88	7					
r vital motion], and (2) the o[riginatio]n or multiplica[tion] of [specie]s.	104	112	144	128	168	128	112	7					
The 'o[rigin]' [o]f a specie[s] is n[ot] more[] evolutio[n]a[ry] than any [o]ther[] stage	104	128	120	128	128	22	96	152	11				
n[] its history. The causes [o]f the s[ub]d[ivi]sio[n] of [specie]s [ar]e n[ot] causes	120	192	88	168	160	264	88	152	120	136	136	11	
[] v[ital] motio[n]; the [two] p[ro]cesses are quite dist[ri]ct. The [se]paration	160	104	160	112	152	450	122	248	9				
f two specie[s] is not a f[ocus] of [] the evolution[ar]y proble[m]; it is [] a mere	88	72	104	376	88	136	112	7					
n[] cid[ent] o[f] d[evolop]m[ent]al histor[y.]	304	176	136	72	272	230	f						
No. of fixations, 68. Total duration, 9,804. Av., 144.1. M., 128. A. D., 47.6.													

¹Note very short pause. Probably not a real fixation, but just a 'hitch' in the eye's movement.

CHART XV, B

READING ALOUD

No. 42 A

Subject S

[A] license for pr[om]otion ma[y] be issued to the ho[lder] o[f] a	442	612	353	272	4						
ea[cher's] licen[se] No. 1 [w]ho[] has h[ad] (e)xperien[ce] rated as [equ]ivalent to	394	279	476	496	265	224	367	96	8		
[three] years o[f] Ne[w] York[] city pu[blic] sc[hool] tea[ching] ¹ ([in]cludi[ng] [one	340	394	238	278	211	190	177	231	150	9	
year[] in the city o[f] New York[]); who passe[s] a n[] examinat[i]on in t[he]	374	286	218	728	299	265	170	7			
princ[iples] and me[tho]ds of tea[ching], or in lieu [th]ereof prod[uc]es evi-[]	252	292	320	510	286	862	6				
No. of fixations, 34. Total duration, 11,437.6. Av., 336.4. M., 285.6. A. D., 121.4.											

¹These parentheses belong in text.

CHART XVI A

USUAL METHOD OF READING

1	ST[⁷⁹³ P]ETERSBURG, Nov. 2.— ²⁹⁶ []The A ³²¹ [d]miralty	3
2	has [t]elegraphed to t ⁴⁶⁰ he o ²¹⁷ fficers of the [B]altic	4
3	[flee]t, who ³²⁵ were left ²⁹⁰ [be]hind at V ³⁷⁰ igo in (or)der	5
4	[th]at the(y) ³³⁶ mig ³¹⁶ ht ³³⁰ testify, an ²⁹⁷ [d] who ²⁷⁰ [wer]e on	5
5	t ³⁸¹ [he]r way to St. ²⁶⁸ Petersburg, [to] remain ³⁴¹ [in] ³⁰⁸	4
6	[Pari]s.	
6	[Ad]m[ir]al K[ax]nakoff, [a m]ember o ³⁵³ f the ²⁰⁷	5
7	Admi ¹⁸⁷ [ralty] Co ²²⁷ []ncil, who ²⁹⁴ was app ³⁷⁵ ointed	4
8	yes ³⁷⁵ [ter]day up ²²⁷ on the interna ²⁰¹ [tion]al com ¹⁶⁷	4
9	missio ²⁶⁸ [n] whic ²⁰⁷ h is to in ²²¹ quire into t ²⁶⁸ [he])North	4
10	Sea affa ²⁷⁴ [ir,] star ¹⁹⁴ [ted] for P ²²¹ [aris] to-d ²⁰¹ [ay.] Hi ²⁵⁴ [s	5
11	a ³⁵⁵ [pp]ointment is ²⁹⁴ [] we ²⁷⁴ lcomed as an ²⁷⁴ []ndication	3
12	that there ²⁸⁸ [] will be [a] thourou ¹⁴⁰ [gh s]earch for t ¹⁸⁷ [he] ²⁴¹	4
13	fac ²³⁴ [ts] o ²²¹ f [] t ²⁸¹ he case. The Admi ²⁴⁷ [ral wo]n go ²⁴⁷ [ld]en	4
14	opinio ²⁸⁸ [ns])among th ¹⁶⁰ e members ²²¹ of the co ¹⁸⁷ [n-]	4
15	vention held in Wa ⁴¹⁵ [shing]ton in 1889 to ¹⁵⁴ for-	2

CHART XVI B

READING ALOUD

1	ST. P ³⁰⁶ [ETE]RSBURG, [N]ov. 2.)—(T ³²³ [he] Ad ⁵⁷² [mir]al ²⁰¹ ty ¹⁴³	5
2	[has])telegraphed t ³⁵¹ o the ¹⁸⁴ offic ²³⁸ ers of th ¹⁸⁴ [e B] [alt]i ¹⁷³ c ⁹²	8
3	fleet, w ⁴¹² h ¹³² o wer ¹⁵⁴ e left ¹⁷¹ behin ⁵⁶¹ d at Vig ⁵⁶¹ [o, in] [ord]er	5
4	tha ²⁹⁰ [t t]hey migh ²¹⁴ t testify, [an]d w ¹⁶⁵ [ho] we ³¹⁹ [re] on ¹⁵⁴ ¹³²	6
5	(th ¹⁹⁸ [ei]r w ¹⁴³ ay to St. ¹⁴⁸ Petersburg, to r ¹⁷⁰ [e]main in ¹⁵⁴ ²⁴²	6
6	[Pa]ris.	
7	[] Admiral ¹⁴³ [Kax]nakoff, a ²¹⁵ [me]mber of [th]e ²¹⁴	4
8	Admiral ¹⁴⁹ [ty] Co ¹²⁵ [u]ncil, (w ¹³² ho wa ¹⁴³ [s app]ointed ³¹⁴	5
9	ye ¹⁸² [ster]day up ¹⁶⁵ [on] the int ²⁶⁰ (er ²⁰⁴ [nati]ona)l ¹²¹ [com-] ³²⁵	6
10	m ²⁹² [iss]ion) which is ²⁴⁷ to [in] [quire])into th ⁹⁹ [e N]orth ²⁰⁹ ²³⁶ ²⁴²	6

No. of fixations, 51; total duration, 11,070σ; average duration, 217.1σ; A. D., 76.7; median, 183.6σ.

§ 3. *Children's Reading*

What is the method of progress and what differences do children show in the ease and rapidity with which they acquire the mechanism of eye movements? Do the backward readers show any anomalies of mere eye movement?

It was at first my purpose to devote a chief part of the investigation to a study of these and similar questions. The adult practice and method is, however, presumably the only criterion we have, and by which we may judge of the progress of the beginner. But little has been determined in regard to the individual peculiarities of eye movement in the case of adults, and it has, therefore, been necessary to confine the experiments almost wholly to the latter subjects. The experiments upon children are, therefore, offered tentatively because of the small number of cases.¹

The records which are reproduced in Plate V and Chart XVII are those of three boys, of nine, ten, and eleven years of age, and from the fifth, fourth, and third grades respectively. The passages read were from the readers in use in the latter two grades. They are presented more to illustrate the differences between adults and children who have learned to read than for their value as illustrative of differences among children. What progress takes place as the child learns to read can, of course, best be studied by repeated experiments upon the same individual.

The records appear, however, to represent several stages of development, which differ in the number and duration of the fixation pauses. The 'Gesamtbild' is evidently much more divided in the case of the youngest subject. This appears in the relative frequency of the fixation pauses. The attention span is much wider in the case of the ten-year-old boy, and at times equals that of the adult whose reading of the same page is also reproduced for purposes of comparison. The more purely physiological difficulties have been fairly well mastered. The rate of movement in the return sweeps and in the interfixation movements is not different from that of the adult. There is some unsteadiness and refixation, but the mere accuracy of fixation appears as exact as that of adults. The chart below shows the location and the duration of the pauses,—the two factors in which there is the greatest difference between child and adult. The overestimation of the return sweep at the beginning of the first lines of Readings B and C is of interest. It is perhaps increased here because of the indentation of the first line.

¹ It is the plan of the writer to supplement this part of the investigation by an independent study.

§ 4. *The Effect of Long and Short Words*

A comparison of the number of fixations and their duration per line in passage 63 A (Chart XX A), composed mainly of short words, with the same passage in Chart XXI A, which is composed of rather long words, may be made as a test of the theory proposed by Messmer,¹ viz., that a succession of small words tends to break up the motor innervation and is harder to read than a passage composed mainly of long words. Record 63 A shows in the first place that it is not necessary to fixate every word. Were the innervation broken into smaller units there is reason to believe that fact would be indicated by an increase in the number of fixations, just as the number of pauses is increased in a foreign language or in difficult passages. A comparison of these charts will show that in the first six lines, of equal length and size of type, 37 fixations are made in the passage of long words, and 35 in the short word passage. There are 79 small words and 54 long words, or an average of 2.3 short words per fixation as against but 1.5 long words, i. e., one and one-half times as many. *It is not the short words as such, but the words which cannot be easily grouped with others which necessitate separate fixation.* The same holds true in the short line arrangements. Attention may be called to the misspelled word in 62 B, line 1, 'gorgeosly.' The subject noticed the misspelling in reading and the record shows that it was carefully fixated.

¹ Op. cit.

CHAPTER XII

THE LENGTH OF TEXT-LINES AND MOTOR HABITS

Very little careful experimentation has been made relative to determining the proper lengths of lines of print; and as a result there has been considerable difference of opinion with very little evidence one way or the other. Weber,¹ for example, believed that "up to a length of 150 mm. (6 inches), but not beyond, long lines make it easier to read quickly. He requires a minimum of 100 mm. (4 inches), a maximum of 150 mm. (6 inches) for the normal line. He wishes, therefore, that school-books should be printed where possible in lines of 140-150 mm."²

Javal, on the other hand, believed 'the long lines to be the reason why progressive myopia is so frequent in Germany. . . He considers that with long lines, short-sighted people must exert their accommodation the more frequently and strongly in the middle of the lines as their eyes are focused for the ends of the lines.'³

Cohn adds: "It seems to me that 100 mm. (4 inches) is the greatest length admissible, and 90 mm. (3.6 inches) the best length for lines of ordinary print where the 'n' is 1.5 mm. high. With larger types a longer line of 110 mm. (4.4 inches) is allowable."

Since differences in phraseology, subject matter, size of type, and length of line, etc., may each affect both the number and length of pauses, it seems evident that the only method of determining the influence of each factor is by elimination of the others. In the case of subject matter it has been noticed that a second reading may often produce but little change, and, if the reading is repeated after the lapse of a considerable length of time, the influence of repetition may be largely disregarded. The method of studying the influence of the length of line on the ease and quickness of reading, has been, therefore, to keep the subject matter, the size of type, etc., and all other conditions uniform. The passage was simply typewritten or printed in two different lengths of line. In the first reading one arrangement of the length of line

¹ A. Weber. Ueber die Augenuntersuchungen in den höheren Schulen zu Darmstadt. Referat und Memorial, erstattet der grossherzoge Ministerial-Abtheilung für Gesundheitspflege. März, 1881.

² Quoted from Cohn: 'The Hygiene of the Eye,' p. 206.

³ Cohn: *Ibid*, p. 205 ff.

was used, and, in the second reading, the other arrangement. Several weeks intervened between the first and second readings, but, in order that there might be no opportunity for practice effect, the long-line passage was read first in one experiment and last in the next, etc. Six of the passages read were typewritten, the height of the small *n* being 2 mm., and two were set up at the printer's in the different lengths of line desired.

The several records will be discussed separately. They appear as Charts XVIII-XXII, but will be cited by their original record number. The passages for this experiment are with one exception chosen from the plain narrative of Robinson Crusoe, in order that there might be as little difference as possible in subject matter in all the tests.

The first set of readings of two subjects of the same passage in long and short line arrangement follows (59 A and 59 B, 68 A and 64 A). Subject S is, in general, a very rapid reader, subject E a somewhat slower reader. Since the lines were typewritten they were not all of equal length; the long line varies between 179 mm. and 190 mm., the short line between 86 and 98. In the average of the lines compared, the long line is just double the length of the short line.

CHART XVIII A

Subject E

No. 59 A

297 192 254 260 260 210 260 167 117
 There was [) betwe|en the|m and |my ca|stle the cre|ek, whi|ch I men|tioned o|ften 9
 the first[p]art of my story, w[he]n I landed |my cargoes| out o[f]my s|hip 6
 403 163 170 290 233 333 226 81 233 195
 d this I kn[ew h]e| must| ne|ces[sar]ily swim o[ver], or th[e poor] [wre]tch [wou]ld 10
 b c a e d f i h g j
 289 768 220 264 264 1245 138 365
 taken ther[e;) but when [the sav]age esc|aping c|am[e th|ither, [he mad[e n]othing 8
 a b c e d f g h
 214 233 239 151 283 428 296 189 170 226
 it, t[hough] the ti|de was| then u[p; but plung[ing] in, [swa]m th[roug]h in| about 11
 b a&c
 189 170 94 163 220 352 264 189 395 182
 irt[y s]troke[s, or (th]ereabo[ut]s, lan[d]ed), and r[an] (on]with |exceeding |strength 9
 a2 a1
 345 326 256 332 537 288 230
 d s[wi]ftness. Wh[en] the (th]ree pursuers| came to th[e)creek, |I found [that 7
 192 211 134 211 172 224 262 230 224 332 166
 o [of] th[em] could (s]wim, bu[t the t[h]ird could| n[ot, [] and [he,) stand[ing] on the 12
 b a c d e f g h i j k l
 No. of fixations, 72; median of fixation pauses, 233.1σ (A. D. 66.7); length of line, 9-189 mm.; total time, 11,088.8σ (5 lines).

CHART XVIII B

No. 59 B

1	There [wa]s b[e]tween them [an]d [m]y c[ast]le	8
	⁹² ¹²³ ¹²⁸ ¹⁴⁹ ²²⁰ ²⁰² ¹⁴¹ ¹³² b a c d g • f h	
2	the cre[ek], which I mentio[ne]d o[ft]en	5
	¹⁸⁹ ¹³² ¹⁴⁵ ¹⁸⁹ b a c	
3	at the f[ir]st pa[r]t) of my[]story, (when)	5
	¹²³ ¹⁸⁹ ¹⁸⁹ ¹⁹⁴ ¹⁹⁴ b a c d	
4	I landed m[y c]argo[s] out of the ship;	4
	²⁷⁰ ¹⁸⁰ ¹⁸² ¹⁵³ b a c d	
5	and thi[s]I kn[ew], he m[ust] necessa[ri]ly	5
	¹⁸⁹ ¹⁰⁸ ⁹⁹ ²⁰⁷ ¹⁰⁸ b a c d	
6	swim o[ve]r, or the poor wret[ch] wou[ld]	4
	²⁶¹ ¹⁹⁹ ²¹⁶ ¹¹² b a c d	
7	be taken(]there; but whe[n t]he savag[e	4
	²⁷⁰ ²¹¹ ¹⁵³ ¹³⁹ b a c d	
8	escap[ing] came (t]hither, he m[ade] noth[ing]	5
	²⁵⁶ ²²¹ ¹⁵³ ¹⁷¹ ⁸¹ b a c d e	
9	of it, thoug[h(th]e tide (w[as] t]he[n] up;	6
	¹²⁶ ¹³⁵ ¹⁸⁹ ¹⁹⁸ ¹⁸⁵ ¹³⁹ b a c d f •	
10	but pl[ung]ing in, s[wam) throug[h in] about	4
	²¹¹ ²⁸³ ¹³⁵ ¹¹³ b a c d	

Length of line, 87-96 mm.

No. of fixations, 50; average duration, 182.4 σ ; total time, 9,118.8 σ .

CHART XIX A

*Subject S*No. 68 A *Second Reading*

	There was b[e]tween them and my castle t]he []creek, which I mentio[ne]d o[ft]en	
	⁴¹⁸ ²¹⁶ ¹⁵⁹ ²⁴⁴ ²⁴⁹ a b c d	
	at (the)first pa[r]t) of my story, when I la[n]ded my cargoes[]out of m[y ship];	
	²⁹¹ ²⁶³ ²⁵⁸ ¹⁴⁵ ²⁰⁶ ¹⁷³ ⁴⁷ ¹⁰⁸ a b c d e f g h	
	[and this] I knew he mu[st] necessa[ri]ly [sw]im over, [o]r the poor wr[et]ch) wou[ld]	
	³⁰⁸ ²³⁰ ²⁵⁷ ²⁰⁷ ²⁰⁷ a b c d	
	be take[n] th]ere; but when the savage e[sc]ap[ing] came (th]ither, he made n[oth]ing	
	¹⁹⁷ ²³⁴ ²¹¹ ¹⁵¹ ²³⁴ ¹⁶⁵ ¹⁶⁵ a b c d e f g	
	of it, [tho]ugh the tide was then up; but plunging in, swa[m t]hroug[h in] a bout	
	³⁸⁰ ²³³ ²⁶⁵ ²⁴⁷ ⁶⁷ ¹⁹⁸ ⁹⁴ a b c d e f g	
	thi[r]ty [stro]kes, or there abouts, [la]nded, and ran on wit[h]exceeding s[tr]ength	
	¹³⁹ ¹⁶⁶ ²⁹² ²¹⁶ ²⁷⁹ ²⁷⁰ ²⁹⁷ ¹²⁶ a b c d e f g h	
	and swi[ft]ness. When the three pursue[rs])came to t]he cre)ek, I fo[un]d t]hat	
	²²⁴ ¹⁸⁰ ²⁵² ²⁶¹ ³⁵⁵ ¹⁸⁹ ⁷² a b c d e f g h	
	two of] them [cou]ld s[wi]m, but the t]hir]d could not, a[nd] he, stand[ing] [o]n) the	
	²⁵⁶ ¹⁸⁰ ¹⁷¹ ²⁴⁷ ²⁵² ¹⁴⁴ ¹⁵⁷ a b c d e f g h	

No. of pauses, 57; average duration, 213 σ , A. D., 60.6. 190 mm. length of longest line, 179 mm. length of shortest.

CHART XIX B

No. 64 A

1	There was b et ween them and my [ca]stle	4
	^{321 204} ²⁰⁴ ²⁸⁶ d ₂ d ₁	
2	the c reek, w hich I men tioned oft en	4
	¹⁸⁸ ²⁰⁹ ²¹⁴ ¹⁷³	
3	at the first par t of my s tory, w hen	4
	²³⁰ ¹⁹⁸ ¹⁹⁸ ¹⁴⁷	
4	I l and)ed my cargoe s out of t he shi)p;	3
	²⁷⁰ ²⁵⁵ ¹⁸³	
5	and this I knew , he must necessa rily	4
	²⁵⁵ ¹⁵⁸ ²²⁴ ¹¹²	
6	swim [ove)r, or the poor wre tch wou d	4
	³³⁶ ¹⁹⁸ ¹³² ¹⁰⁷	
7	be take)n)there; bu t when t he sa vage	4
	²⁶⁵ ⁹¹ ¹⁷⁸ ⁷⁶	
8	escap ing cam[e) th th er, he made n othing	4
	¹⁷⁸ ²²⁴ ¹⁵³ ³¹¹ b a	
9	of it, th[oug)h the tide was then up;	3
	³⁰⁶ ²²⁰ ¹⁶⁸	
10	but [pl)unging i)n, swam thr ough in [ab)out	4
	²⁵⁵ ¹²² ²²⁹ ¹³²	
11	thirt hy) strokes, or thereab outs, l an-	4
	²⁸² ²²⁴ ¹⁵³ ³¹	
12	ded, (and)ran on wi th exce ding st rength	5
	¹⁶⁸ ¹³² ²²⁴ ¹⁸³ ¹⁰² b a	
13	and sw ift)n[ess. Whe(n) the [th)ree pursuers	4+
	¹⁷³ ²⁴⁴ ²⁴⁹ ²⁶⁰ b a	

47

No. of fixations, 47; average duration, 200.4σ; total time, 9,419.5σ.

CHART XX A

No. 63 A

the boat[swa)in was killed upon t he spot; t he next [m)an was sh[o)t in t he	6
	²⁴⁰ ²⁵⁰ ¹⁹² ¹⁹⁷ ¹⁶³ ¹⁵⁴
body[, a)nd fell jus(t)by him, though he did not die [unt)il an hour[o)r two	6
	²⁵⁴ ²⁴⁰ ²⁵⁹ ²⁷⁸ ²³⁵ ²⁶⁹
(fter); and the thi rd)ran for i)t. At th[e)noise of th[e fi)re, [I)immed-	6
	²⁸⁸ ²⁰³ ²⁵⁹ ²⁴⁵ ¹⁶³ ¹⁸²
te[ly ad)vanced with m y whole army,)which was now eight [men; viz. my-	6
	²⁰² ²⁰⁶ ²⁴⁰ ²¹⁶ ¹⁸⁷ ⁵⁰⁴
elf, generali[s)simo; Frida(y,)my lieutena[nt-g)eneral; the c[ap)tain and	5
	²⁴⁵ ³⁴¹ ³¹² ²⁴⁰ ³⁷⁰
[s tw)o men, and the[th)ree pris)oners of war[,)whom he [had) trust[ed wit)h	6
	²⁶⁹ ¹⁰⁶ ²⁵⁴ ¹⁸⁷ ²⁴⁵ ²⁶⁴
arms. We came up[on) them indee[d) in the dark, so) that [the)y could[no)t	6
	⁴¹⁸ ²⁶⁴ ²¹¹ ²²¹ ¹¹⁰ ¹⁵⁴
ee our n[umber;) and I made th[e m)an they had l[ef)t in the boa[t,) who[was)	5
	³⁰⁷ ²⁷⁸ ²²¹ ¹⁹² ¹⁷⁸
ow one o[f u)s, to call th[em) by name, t[o) try if I [co)uld bring them to a	4
	³⁰⁴ ²⁹³ ¹⁴⁴ ¹⁷⁸

Length of line, 178.9 mm.; No. of fixations, 35 (6 lines); average duration, 244.2σ; total time, 8,548.8σ.

CHART XX B

No. 69 A

Passages of Long Words

1. Th²⁴⁴e bo⁹⁰a|tswai¹¹⁷n) was k²⁷⁰illed upon| the sp¹¹⁷ot; ¹⁴⁸ 6
 c b a d
2. [²⁷⁰) the next [ma²³⁹n was shot [in²¹⁷ the bod²⁷⁶y,) and 4
3. f[e³⁰⁷ll just by h[im,) though²⁶⁰ [he¹⁹¹ did not [d¹⁹¹ie 4
4. un|til¹⁹¹ [a²⁵⁴n hour or two a²⁷⁰ft¹⁷⁰er; and [th⁸⁵e thi⁸⁵rd 5
 b a
5. r[an for it. [At the noi³⁵¹se of the fi²⁷⁵re), I¹⁴⁰ 81 5
6. i[mme²⁹⁷diately advanc²⁹²ed with my [who²⁷⁰le ar⁸¹my, 4
7. [wh²⁷⁵ich was now ei³⁸⁹gh³⁰²t men; viz. [m¹⁰³yself, | gen- 4
8. e[r²⁷⁵alissimo⁴⁴; F⁸⁸ri¹⁸⁷day, m²⁸¹[y] lieutenant|general; ¹¹⁰ 6
 b d c
9. t²⁵³he captai⁹⁹n and his t²⁹⁷wo m¹⁷⁶en, and the [t¹⁷⁶hree 4
10. [pr²⁹²isoners of w¹⁷⁰ar), whom he [had) truste¹⁶⁵d [wi¹⁴⁹th 4
11. arms. | We came upon them indeed in the

—
46

Lengths of line, 90-106 mm.; No. of fixations, 46; average duration, 204.3σ; total time, 9,400.0σ.

CHART XXI A

No. 62 B

- 260 334 236 341 422 434 464 373
 T²⁶⁰he gorg³³⁴e|osly co²³⁶stumed impe³⁴¹rial plenipote⁴²²ntiary suff⁴³⁴fe⁴⁶⁴red excruc³⁷³iating 8
 b c a d
- 815 415 409 558 347
 [an]guish at the rec⁴¹⁵ol⁴⁰⁹lection of his [perso⁵⁵⁸nal thoughtle³⁴⁷ssness and care³⁴⁷less 5
- 496 415 415 617 335
 [ne]ss. There lay⁴¹⁵ [be)fore him the rece⁴¹⁵(n)tly appointe⁶¹⁷d| ambassa³³⁵dor but |now 5
- 322 384 359 502 372 260
 r|uthlessly murde³⁸⁴red by an hi³⁵⁹reling ass⁵⁰²(assin). Although (ther³⁷²e undoubt²⁶⁰ed- 6
- 416 384 310 329 409 397
 ly| existed severa⁴¹⁶l| indicatio³⁸⁴ns of his perso³¹⁰nal innoc³²⁹(ence,) what [people) of 6
- 378 366 180 397 360 320 174
 i[n]te³⁷⁸lligence would| hesitate t³⁶⁶o procla¹⁸⁰im| the start³⁹⁷ling |circumst³⁶⁰antial ev³²⁰|i- 7
- 360 484 316 453
 [dence) prepond⁴⁸⁴erou³¹⁶sly| conclusi⁴⁵³ve. 4
 a b c

No. of fixations, 41; average duration, 378.2σ; total time, 15,506.0σ.

—
41

CHART XXI B

No. 69 B

1	The go ⁶⁵ orgeously ²⁶⁵ [c]ostum[e]d imper ³¹⁰ [ial] ple ²⁴⁵ ni ¹⁵⁵ -	5
2	pot ³²⁰ [en]tiary suffe ³²⁵ [r]ed excru ²³⁵ [ciating a]nguish ¹⁴⁵	4
3	a ²⁸⁵ [t t]he recolle ²⁵⁵ [c]tion of his per ²⁴⁰ [s]onal th ¹⁰⁰ [o]ught-	4
4	less ²⁷⁰ ness a ³⁰⁰ [nd] careless ²⁵⁰ [ness]. There ¹⁴⁰ []lay be-	4
5	fo ²⁸⁵ [re h]im the recent ²³⁵ [ly] appointe ²⁸⁰ [d] ambassa ¹²⁵ [dor]	4
6	but no ³¹⁵ [w r]uthless ²⁶⁰ [ly] murdered ¹⁵⁵ b ¹²⁵ y an hire ¹⁶⁵ [li]ng	5
7	a ¹⁸⁵ [ss]asin. Although ¹²⁵ [t] here undoub ²⁵⁰ [t]ed ²⁶⁵ [ly] ex ¹⁷⁵ -	5
8	iste ³⁵⁰ [d sev]eral ind ²⁴⁰ [ications] of his persona ²⁰⁰ [l]	4
9	innocenc ³¹⁰ [e,] what people ²⁹⁵ of intelli ²¹⁰ [ge]nce	3
10	would hesitate to proclaim ³²⁰ [th]e start ¹⁴⁵ [li]ng ²⁷⁵	4
11	cir ¹⁰⁵ [cums] tantial evidence prepo ¹⁷⁵ [nde]rou ²⁷⁵ [sly]	4
12	conclus ²⁷⁵ [ive].	1
		<hr/> 47

No. of fixations, 47; average duration, 222σ; total time, 10,670σ.

CHART XXII A

No. 68 B

And this ³⁰⁹ old savage ¹⁷⁶ was in the ²¹⁵ [(rig]ht, for, as ²⁴⁹ [I u]nderstood ²⁰⁶	5
since by other ²⁵⁸ hands, the sa ²²³ [vages of that p[art] never ²⁴⁹ [at]tempted ¹⁰⁷	5
[to)go over to the island ²¹⁵ [a]fterwards. Th ¹⁸⁰ [ey)were so terri ¹³³ [fied	4
wi ²⁵⁶ [th] the accounts g ²³⁸ [iven by these fo ¹⁸⁰ [ur)men (for it se ²⁰² [e]ems t ¹⁴⁴ [hey	5
[did) escape the ¹⁹⁸ sea), that th ²²⁰ [ey) believed w ¹⁸⁰ [ho]ever went t ²²⁰ [o t]hat	5
enc ³⁹⁶ [hant]ed island w ⁹⁹ [ould be destroyed ²²⁹ [w]ith fire fr ²²⁹ [om the g ⁵⁴ [ods.	5
T ²⁶⁷ [his,)however, I knew not, an ²³⁵ [d therefor ²⁷² [e w]as under [cont]inual ²⁸⁶	5
ap ¹⁷³ [pre]hen)sions for a goo ¹⁴⁵ [d)while, and kept ²⁸⁶ [a]lways upon my ³¹⁹	5
gu ³⁴⁰ [a]rd, I and all ³⁵⁰ my army; for as ³⁰² [the]re w[ere] now f ²²⁵ [our o]f us, ³⁰²	5
I wo ¹⁷⁷ [uld have ventured up ¹⁹⁶ [on an hund ²⁴⁰ [red] of them [fairly i]n ²⁰¹	5
the ³³⁶ [o]pe]n field at any tim ²⁷⁸ [e. In a little time, ²⁹⁰ however, no more ²⁰¹	5
	<hr/> 54

Fixation pauses, 54. Average duration, 225σ; A. D., 50 (M., 229.5; total time, 12,196.1σ (11,621σ for 51 pauses).

CHART XXII B

No. 63 B

²⁶⁰ (An)d this ¹⁶⁷ [ol]d savage ¹⁹⁵ [w]as in th[e] ¹³¹ righ[t, f]or, as 1 5
³¹⁹ und[er]stood ²⁸² sin[c]e by other ⁵⁷ [h]ands, ²²⁷ [t]he savages of 4
²⁶⁹ t[hat] part never ²⁴¹ [a]ttempted to go o[ve]r to the ¹⁹⁰ i[s]la⁶²nd 4
²⁶² [a]fterwards. They ¹⁹⁵ [w]er[e] so ¹⁰⁹ [t]errifi[ed] with th[e] ¹⁵⁹ [ac]- 4
²⁹³ [ca]unts given by ²⁰⁸ [t]hese four ¹³² [me]n (for it seem[s] th[ey] 4
³⁴³ did [esc]ape the sea, th[at] th[ey] believed ²³¹ [wh]oever 4
²³⁹ wen[t] to th[at] ¹¹⁸ enchante[d] is)land ¹⁴⁹ wo[ul]d be destr[oye]d 4
²⁹⁹ w[ith] fire from the ¹⁷² g[ods.] This, howev[er], I kn[ew] 4
²⁸⁶ [not,] and therefore ²¹¹ [w]as under ²⁰³ [co]ntinual ap[re]h- 4
²⁴⁶ so[ons] for a good ¹⁸⁰ w[hil]e, and kep[t] always ²³³ [up]on m[y] 4
²⁵⁵ [gu]ard, and I and al[l] ²⁹⁵ my army; for ²⁹¹ [as] there were ¹⁶³ [now] 4
³⁴³ (f]our of us, I wo[ul]d hav[e] ventured ²⁷⁷ [up]on an ²²⁰ [hu]n- 4
²⁶⁴ dred [of t]hem fa[ir]ly in the ¹⁸¹ op[en] ²⁵¹ field at any time. | 4
¹³⁷

No. of fixations, 53; Average duration, 206.8 σ ; total time, 10,963.0 σ .

CHART XXII C

No. 58 A

Subject E

⁴⁵² And [thi]s old sa[vage] was i[n] the ¹⁶⁷ rig[ht], (fo[r], a[s] I ¹⁹² und[er]stood 7
²⁴⁸ since by] other hands, ¹⁵⁵ [t]he sa[vages] of that ²²⁰ part ³⁵⁴ n[ever] ¹³⁰ attempted 5
³²⁸ to go) o[ve]r [to] ²⁴⁸ th[e] ³⁴⁷ island ¹⁷³ aft[er]wards. Th[ey] ³¹⁶ w[er]e ¹⁴⁰ so ¹⁷⁹ terrifi[ed] 7
³⁵⁴ wit[h] the ²¹⁰ accou[n]ts gi[ven] by the[s]e four ²⁹⁷ m[en] (²¹⁶ for ¹⁹² [i]t ³⁷² seem[s] they 7
³⁰⁶ did e[sc]ape the ¹⁹⁸ sea), that th[ey] believe[d] ²⁴¹ wh[o]ever ¹²⁴ w[en]t ⁴⁰³ [to] that 6
³⁴² ench[an]t[ed] islan[d] would ¹⁰² b[e] ¹⁸⁶ destroye[d] ²⁴⁶ w[ith] ⁴³² fir[e] ¹²⁰ fr[om] ²⁰⁴ the gods. 7
²¹⁶ This, ho[w]ev[er], I ¹⁴⁴ kn[ew] ⁹⁶ n[ot], and ¹⁸⁰ [t]herefo[re] ¹⁹² wa[s] ²⁸² unde[r] ¹⁶² [co]ntinual 9
¹⁸⁶ app[re]h[ensions] ¹⁸⁶ for a ²²⁸ g[oo]d ³⁴² while, ³⁰⁰ and ³⁵⁴ kep[t] ⁴⁰⁸ alw[ays] ²⁵⁸ up[on] my 8
³⁰⁰ gua[r]d, I ²⁶⁴ an[d] ¹⁵⁰ a ²⁰⁴ ll] m[y] ²²² army; for as there were now four of us,

Fixation pauses, 61. Average duration, 243.8 σ (M., 228); A. D., 76; total time, 14,870 σ . Length of line, 113.5 mm.

A comparison of the charts shows that in each case more fixations are required in the short line in order to read the same number of words,¹—47 as against 40 for S, (68 A and 64 A), 50 as against 44 for subject E (59 A and B), or from $\frac{1}{6}$ to $\frac{1}{8}$ as many again. A tendency to a motor habit, which is evinced by a repetition of the same number of fixation pauses in successive lines, is evidently more marked in the short lines of each subject than in the long. It is more successful in the readings of subject S than in those of E. In the latter's reading of the long line there is no indication at all of a motor tendency. No two successive lines have the same number of fixations.

The same results appear in the readings of 63 A and 69 A (subject S). In this case the long line was read first. There are 35 fixations in the long line, 46 in the short line. These are printed in Charts XX A and XX B on pages 102 and 103. Similarly, in records 62 B and 69 B, which are printed in Charts XXI A and XXI B on pages 103 and 104, the short line is three-fifths of the long line. The latter requires 41 fixations for the passage, the former 47. *The span of attention is therefore somewhat smaller in the short line.* The increase of pauses in 69 B is doubtless, however, due in part to the necessity of carrying over long words divided at the end of the line.

Cf. 'plenipote|ntiary' in long line with 'ple|ni-
pot[en]tiary
also 'There lay[be]fore him' with 'There[]lay |be-
fo[re h]im'.

Subject E believed that in reading passages of this character (as No. 59 A) he was accustomed to move his eye 'down the middle of the page.' That this is what was attempted, although quite unsuccessfully, is perhaps shown by the first fixation of line 3, No. 59 A. The subject was evidently hampered by a line of this length. It may be noted that in line 6 'thirty' was misspelled 'thirthy' in the original paragraph, the backward movement of the first fixation and partial stop at (b) may denote the observance of that peculiarity. Both subjects S and E had been reading some proof and hence were more apt to notice these irregularities.

To summarize, more fixations are made in the short line arrangement than in the long, e. g., 44 fixations for 5 lines of 59 A

¹ When all the lines and fixations of a passage are not taken for comparison, the number actually compared is indicated in the margin of the charts. For example, the first five lines of Chart XVIII A on page 100 contain the same number of words as the first ten of Chart XVIII B on page 101; the number of fixations in the first five lines of the first passage is, therefore, added and placed in the margin after the fifth line. So also in Chart XIX A, page 101, the first six lines only are needed for comparison with the short lines of XIX B on page 102.

(long line) as compared with 50 fixations for 10 lines of 59 B, (subject E); 40 fixations for the same passage as read by subject S, (68 A) (the first six lines of the long line arrangement), and 47 in the short line arrangements of the same words; 35 fixations in six lines of 63 A (long lines of short words) and 46 fixations in the same amount of subject matter arranged in ten lines in 69 A.

In these cases the long lines are twice or nearly twice the length of the short lines. In 68 B the line is less than a third as long again as 63 B. The same fact holds true, but to a very much less extent, the number of fixations being 51 for the long line, 53 for the short. The long line is in this case of but 113.5 mm., the short of 87.5 mm. As this is a printed page, the difference is, however, largely counterbalanced by the larger number of words or letters per line. This advantage is secured by the greater compactness of the type setting and spacing. On this account the short line of 63 B is practically as advantageous as the longer line of No. 68 B as regards the number of movements and fixations that are necessary, and it has several advantages which are lacking in the longer line; first, its length is better suited to the formation of short-lived motor habits, and, secondly, it has an advantage in that it can (perhaps on this very account) be read in less time.

The first four short line passages because of this difference in the compactness of type and spacing have too few words to the line. The passages are too much divided, or cut up, and cause an unnecessarily large number of fixations per line. They, as will be seen, have an advantage in respect to the two desiderata, i. e., rhythmical movements and short duration, just mentioned in the case of No. 63 B, but, whereas in this latter passage the span of attention (as denoted by the small number of pauses) was as extensive as in the longer line, it was, so to speak, unnecessarily 'cramped' in the former passages.

TABLE X

Total number of fixations in lines of different lengths made in equal amounts of the same subject matter read by the same person at intervals of twenty days. I. Long line arrangement. II. Short line arrangement.

Nos. of Record		Ratio Length	No. of Fixations		Lengths of Lines		Av. No. of Letters per Line	
I	II		I	II	I	II	I	II
68A	64A	2-1	40	47	179-190	86- 98	57	29
59A	59B	2-1	44	50	179-190	86- 98	57	29
63A	69B	5-3	35	46	179-178	97-106	52	30
62B	69B	5-3	41	47	179-183	97-106	62	38
68B	63B	1½-1	51	53	113.5	87.5	49	37

To consider next the duration of the pauses, it will be noted (cf. Table XI), that the average duration of the pauses is uniformly less in the shorter lines. When the short line is made of sufficient length and printed in such type and spacing as make wider fixation groups possible, and so equalize the number of pauses, the *total* time per passage is also decreased. It is probable that the 'practice effect' carried over in some cases; particularly might this be the case on account of the peculiar style and subject matter that is found in 62 B.

TABLE XI

Duration of fixation in long and short lines compared

	Records	Total Times	Av.	No. of Fix.	Av.	A. D.
Long line.....	68A	8481.0	212.0	40	6.6	.7
Short line.....	64A	9419.5	200.4	47	3.9	.31
Long line.....	59A (5 lines)	11088.8	252.0	44	8.8	1.3
Short line.....	59B (10 lines)	9118.8	182.4	50	5	.8
Long line.....	63A (6 lines)	8548.8	244.2	35	5.9	.23
Short line.....	69A (10 lines)	9400.0	204.3	46	4.6	.72
Long line.....	62B	15506.0	378.2	41	6.1	.52
Short line.....	69B	10670.0	222.0	47	4.2	.45
Long line.....	68B	11621.1	227.9	51	4.9	.09
Short line.....	63B	10963.0	206.8	53	4.	.1

As has been suggested, the data presented seem to the writer to warrant the hypothesis that the differences in the rate of reading in the case of the same individual and between different individuals depend largely, when other conditions are constant, on the ease with which a regular rhythmical movement can be established and sustained. The peculiarities of this movement are two, first, a succession of the same number of pauses per line, and, secondly, a certain fairly uniform arrangement in the order of long and short pauses, viz., (1) the first pause of a line longer than succeeding pauses, and (2) a secondary increase in the duration of the pauses near the end of the line. These peculiarities are mutually dependent, and they are due chiefly to differences in the length of the text lines. If the line is of such length that it is not possible to secure at the first fixation of the line a fairly definite impression of a large part of the line, the eye must advance, so to speak, more cautiously, and devote its attention more equally to each section. The reasons for this are: first, that the peripheral perception being less exact, there is danger of confusion with the lines lying immediately above or below the one being read; secondly, the incidental but constant concurrent impression of words

lying in the lines above and below and in fact the general characteristics of those lines, are of no particular value and not infrequently distracting in the case of the long line, but are doubtless a distinct advantage in the short line. Suppose, for example, that when the eye is fixating at the beginning or end of one line, a few words from the next line are caught sight of. If this happens in a very long line, the words would have little or nothing to do with the immediate sense, and must, therefore, be disregarded; whereas in the short line there are fewer intervening words and ideas, so that the peripheral vision (as a fringe of subconscious perceptions) may aid in keeping the sense. So also in the case of misunderstandings, words which are connected with those being read are found in greater proximity in the shorter line and can be more easily referred to. In a long line the matter lying immediately above is more apt to belong in another sentence.

The data upon which this preliminary statement is based is the following. In Table XII the median and average durations of all the first fixations of each line, all the second, third, etc., are given for the first four charts of this section, i. e., 63 A—long line, subject S; 69 A, (same subject matter in short line arrangement) 59 A, and 59 B, long and short line arrangement respectively (cf. Table IX above for similar distribution), subject E. It will be noticed that in each case the extent of the acquirement of a series of movements with the same number of fixations varies concomitantly with a close approximation to the above noted distribution of the time of fixation. The duration of the pauses in the long lines is more nearly the same in all parts of the line. The number of pauses per line is more nearly uniform in the reading of Subject S (cf. 68 A) than in that of subject E, and it may be observed that the pauses towards the end of the line, i. e., the fourth, fifth, and sixth, are somewhat shorter for S. The long line is read by E with an alternation of long and short pauses. It seems to substantiate the suggestion made earlier that often every alternate fixation in the long lines tended to have a somewhat wider scope than the others. In neither case is there the constant decrease that is found in 69 A (short line, subject S).

There is in this record first a long pause followed by a much shorter pause, the third pause is again long, and followed by a constantly decreasing duration of pauses towards the end of the line. The same is true to a less extent in the short line of subject E (59 B), but the acquirement of a motor habit was not as successful in the latter's case, (cf. Chart XVIII B), and, therefore, the above noted succession and duration is concomitantly less marked. In Table XII the distribution of time is given by fix-

tions for the long lines, and in Table XIII the distribution for the short lines. The accuracy with which the median and average deviations indicate the above noted tendencies may be verified by a comparison of the charts themselves.

TABLE XII

Distribution of the medians of all first, second, third, etc., fixations. I. Long line arrangement. II. Short line arrangement

SUBJECTS S AND E

		1st Fix.	2d Fix.	3d Fix.	4th Fix.	5th Fix.	6th Fix.	7th Fix.	8th Fix.	9th Fix.	10th Fix.	11th Fix.	12th Fix.
I 63A	M	268.8	264.	240.0	216.0	182.4	223.2						
	A. D.	51.7	44.8	35.2	25.6	51.8	91.2						
I 69A	M	275.2	180.6	257	159.0	100.7	129.2						
	A. M.	35.3	91.6	41.0	52.7	57.8	19.2						
I 59A	M	290.6	231.1	226.3	254.9	262.5	255.1	333.1	260.0	189.	195.3	279.8	160.4
	A. D.	47.9	131.6	43.1	38.4	82.7	47.2	56.2	83.9	30.1	20.1	53.0	0
II 59B	M	189.2	180	166.5	153.0	139.5	220	132					
	A. D.	39.3	46.6	27.9	24.7	32.2	0	0					

TABLE XIII

Distribution of time in long and short lines

TABLE A.¹ SHORT LINES

		1st Fix.	2d Fix.	3d Fix.	4th Fix.	5th Fix.	6th Fix.	7th Fix.
69A	M	275.2	180.6	257.0	159.0	100.7	129.2	
	A. D.	35.3	91.6	41.0	52.7	57.8	19.2	
69B	M	285	255	240.0	140	175.0	165.0	
	A. D.	64.1	47.7	31.4	49.0	26.7	0	
14A	M	255.	198.9	198.9	147.9	102.0		
	A. D.	46.3	43.0	29.	64.	0		
59B	M	189.2	180	166.5	153.0	139.5	220.	132
	A. D.	39.3	46.6	27.9	24.7	32.2	0	0

TABLE B. LONG LINES

63A	M	268.8	264.0	240.0	216.0	182.4	223.2						
	A. D.	51.7	44.8	35.2	25.6	52.8	91.2						
62B	M	378.2	384.4	359.6	396.8	365.8	362.7	328.6	272.8				
	A. D.	72.8	43.4	64.7	107.3	26.9	60.4	155.					
59A	M	290.6	231.1	226.3	254.9	232.5	255.1	233.1	260.0	189.0	195.3	279.8	166.4
	A. D.	47.9	131.6	43.1	38.4	82.7	47.2	56.2	83.9	30.1	20.1	53.0	00
58A	M	328.6	198.4	241.8	222	300	310	179.8	273	187			

¹The average deviations are in some cases large, but in view of the many factors (as difference in subject matter, etc.), which would work against uniformity, as well as the individual differences of subjects, and since the tendency to concomitance is itself so marked and constant, it is believed the conclusion is justified.

The distribution of the length of time spent in the different parts of a sentence depends more upon the chance location in the line of print than on any characteristics of the separate parts of the sentence itself.

The subtraction of several millimeters from the end of long lines is a sufficient change to increase the duration of the initial pauses of the given lines, and to cause a difference in the distribution of the duration of the other pauses. The addition of several letters to the ends of short lines has the exactly opposite effect. Other factors, as pointed out, enter somewhat into the explanation of this change, but the most important factor is the mere difference in the length of line.

In Tables XIV A and B, the total duration of all the first fixations, of all the second fixations, etc., in a given passage is shown. The four passages are selected at random from the charts presented in earlier sections. Table A is of long lines, Table B of short lines (i. e., newspaper). The number of fixations in each class is added as a check on the total durations. The facts are the same as above illustrated.

TABLE XIV

Distribution of the total duration of all the first, second, third, etc., fixations in four passages

A. LONG LINES

No. Rec.	Passage	Whole Sum	1st Fix.	2d Fix.	3d Fix.	4th Fix.	5th Fix.	6th Fix.	7th Fix.	8th Fix.
14A	Evolutionary..	11811.4	2751.1	2563.5	1897.4	1797.3	1522.7	1067.4	212	
32A	Evoluting.....	13055.3	2418.5	1929.5	2156.3	1595.3	1360.9	2023.0	571.8	

B. SHORT LINES

No. Rec.	Passage	No. of Fix.	Whole Sum	No.	1st Fix.	No.	2d Fix.	No.	3d Fix.	No.	4th Fix.	No.	5th Fix.
32B	St. Petersburg	60	16629.8	15	5366.7	15	3367.8	14	3718.7	12	3085.4	4	1091.2
43A	St. Petersburg	25	5307.5	8	2469.6	8	1620.8	7	1033.1	2	234.		

In 14 A, Table XIV, a succession of the same number of fixation pauses per line is attained in a longer line than is usual, and it is interesting to note that the distribution of time in the fixations corresponds to that usual in the short newspaper lines, and

seldom in the long. That is, we find a long first fixation followed by shorter ones with an occasional secondary increase towards the end.

Perhaps a better method than either of the above to illustrate the tendency which may be seen best by a study of the charts themselves would be to divide somewhat artificially the lines into thirds or fourths, and count the duration of all fixations which fell within those limits. The predominance of longer fixations in the first quarter and a half of the shorter lines, might thus be best illustrated. A brief study of the charts will, however, be sufficient for the purpose.

We may now recur, at the risk of some repetition, to the question that was raised earlier in the discussion, as to whether it was the effect of subject matter or merely of length of lines which caused the difference in the distribution of times. Is the first fixation on the average longer because the eye must needs come to a full stop there from the long return movement, and because, secondly, it must read in this case both to the right and to the left of the point of fixation, whereas in the succeeding pauses it need read only towards the right? If the longer pauses were due simply to this physiological difficulty, it should occur as noticeably in the long line as in the short, in fact the preponderance should be in favor of the long line because of the greater momentum of the return sweep. The records, as above noted, show, however, that this characteristic is peculiar chiefly of the short line.

To summarize, the fixation pauses are uniformly longer at the beginning and at certain other parts of the line. The reason assigned for this peculiarity is that at these places a more general perception is secured of the ideas and words that follow in the line. The succeeding fixations serve to amplify and fill out this general perception. Finally, this expanding of the field of attention is made more frequently and with greater ease in the short line. Since, therefore, it is easier to read when attention and fixation coincide, it is advisable that the arrangement of printing should be so made that the distracting effect of unconnected words on the periphery of vision is minimized and the more important and salient parts of the sentence be found in those places where the eye for more purely physiological reasons naturally dwells.¹

¹It was the intention of the writer to supplement this part of the discussion by suggestions, which seem feasible, and certainly help towards the legibility of sentence structure in print. Their publication, however, has been delayed due to the lack of sufficient experimental data to warrant their appearance at this time.

The elementary school books may again, unfortunately, be taken to illustrate the violation of these conclusions regarding the length of text lines. It is not an uncommon practice to have the first readers somewhat wider than is common in general in books of that size, and wider than the second readers that are next read. Promotion from the primary and second grades to the third or fourth grade often means in very many schools a change from a comparatively long line to one which is a third shorter. If the long line must be used at all, it should from every point of view come later.

The length of text line which is used in several pages of a school primer in very common use at the present time is 120 mm. This is a longer line than that of any other book on my shelves, and a third longer than that of the majority of books and magazines in general. Several of the pages in question are printed in type but $1\frac{1}{2}$ mm. in height, and in addition the margins of the lines are indented for pictures. A part of one of the pages is printed below. As can be seen from a comparison of this page with the one prepared with a view to testing this difficulty (cf. 'Refixations'), this passage, as regards the ease of acquirement of a uniform motor innervation of the eye muscles, is on the whole the much more difficult passage. Although the type was smaller (1 mm. for the small 'n'), and the spacing narrower in the passage experimented with, the length of the line was but 97.5 mm. as compared with 120 mm. in the following passage, and the indentations were but 30 mm. and uniformly of that extent. In this case they are 56.5 mm. on one side and 45.5 mm. on the other. The extent of movement is, in the case of four lines (supposing the eye to come to the edge of the page), reduced from 120 mm. to 74 mm., and in the case of five other lines to 63 mm.; that is, the extent of motor innervation must be changed by from one-half to a third of its total extent. The extent of the return sweep from the end of one line to the beginning of the next is in one case reduced to less than 17 mm., or about one-seventh of its usual extent. The acquirement of a uniform motor habit of eye movement is manifestly impossible in such a line arrangement.

CHART OF LONG LINES AND FAULTY LINE ARRANGEMENT
FROM A SCHOOL READER

By and by the Sun saw Bessie and Mary start from home, and he watched them until they reached the kindergarten.

The Sun looked into the kindergarten, and through the windows, he sent bright-colored fairies dancing along the walls, around the chairs and over the piano. These are the chairs and the piano.

Here the Sun loved to linger and to see the happy children working and playing together.

Twelve o'clock came and the little ones went home. The Sun was now

very high in the sky; but he managed to peep into the windows of the dining room and to catch a glimpse of papa, mamma, Bessie, and Mary seated at the lunch table.

These are the chairs and table.

Soon the station was reached, and then there was a long, dusty ride in the carriage. It did seem rather hot, but the Sun was doing his best to make the flowers smile and grow beautiful. A drink, sparkling and clear from the well, refreshed every one.

This is the well.

The water at the bottom of this deep for, try as he would, the Sun never could "Never mind," he said, "I suppose thing cool these warm days, and so I by making the water in the brook like a hundred rainbows."

well was very cold, catch a glimpse of it. people do want some- will content myself sparkle and flash—

It is in the writer's belief clearly indicated by the above experiments that one of the essentials of natural and rapid reading is that the reader's eye should at once be able to acquire a regular and uniform motor habit of reaction for each line. When the length of line and other conditions remain constant this tendency to a uniform system of movement can be quickly developed whatever, within certain limits, the nature of the subject matter may be. But, if no two lines are of the same length, as in the case in the above passage, this is not only impossible, but the uncertainties and difficulties of accurate movement, already described in the case of a practiced adult, and indicated by the number of misjudgments of correct muscular movements, regressive movements, and re-fixations in general, must naturally lead to a more cautious mode of eye movement. This will be hard to overcome later, in the case of children, and may cause unnecessarily slow readers. It is, of course, true that the child at the start confines his attention to very small sections and groups of words, and will not for some time acquire a method of more general 'prevision' of the line as a whole, but that gives evidently no justification for practicing him on line arrangements which even the skilled adult finds difficult to compass.

The problem of the best length of text lines can naturally not be answered apart from a consideration of the size of type, the number of letters per line, and the spacing between lines, and similar questions.¹ It has not been possible except incidentally to extend the investigation to these questions. As several sizes of type have been used in the experiments, however, it can be said that the size of type should not be so large in comparison with the length of line that but few words can be put on a line. The effect produced is to make the passage disconnected and to increase unnecessarily the number of movements and pauses. This was true of the short typewritten lines.

A line of from 75-85 mm. or about a third longer than the ordinary newspaper line of the New York dailies with type 1.5 in height (of small letter 'n') combines a good many advantages. An increase of spacing between lines, as is done on the editorial pages, for example, increases legibility as much as a larger size of type.

¹ Cf. for these matters Griffing and Franz, *Psychological Review*, 1896, 512-530.

CHAPTER XIII

RAPIDITY OF READING

In order to give a somewhat wider scope to the experiments, the subjects were selected with a view to detecting such individual differences in the methods of reading as might exist. As the wide difference in the rate of reading is perhaps the most noticeable individual peculiarity, this was made the basis for the selection of most of the subjects. In order to get the extremes, the slowest and the most rapid readers were selected from a group of about thirty people. The selections read were simple narratives which would seem as likely as possible to be equally familiar in style, etc. To various factors, such as differences of interest in the tests, the practice effects from reading in one kind of subject matter,—as novel or newspaper,—factors which doubtless ought to be considered in any experiments which have the question of the rate of reading as the primary problem,—it did not seem necessary to devote special attention. The sole purpose was to find subjects which fell within the general classes of rather slow readers and rapid readers. Several series of experiments with a large variety of different subject matter and under widely different conditions supported the observation that certain individuals read more rapidly on the average in all cases, although the comparative ratio in degree of rapidity varies according to subject matter.

In Table XV the number of words read in 20 seconds by the three fastest readers and by the five slowest readers of the group are given. The subjects are arranged in the order of rapidity of reading. There were nine different passages each selected from "Robinson Crusoe," and printed on a separate sheet of paper. Nos. 1-3 were printed in 12-point, Nos. 11-13 in 10-point, and Nos. 21-23 in 8-point type. Passages 1, 11, 21 were printed in what is known as modern style of type, passages 2, 12, and 22 in old style, and 3, 13, and 23 in 8-point 'Scotch' style of type.¹

¹ I am indebted to Prof. Thorndike for securing these blanks from the printers.

TABLE XV

Rate of reading (No. of words read) of eight subjects

	Rate of Reading (No. of Words Read) of 8 Subjects								
	12 Point			10 Point			8 Point		
	1	2	3	11	12	13	21	22	23
1	229	211	196	228	203	235	222	217	220
2	197	188	187	190	179	179	191	185
3	165	165	142	185	199	182	170	180
4	111	121	100	109	105	129	118	100	117
5	101	94	100	111	92	108	113	99	102
6	93	105	100	101	118	95	96	84	93
7	85	105	88	95	93	101	93	96	96
8	68	64	62	63	63	67	68	61	60

The principal line of demarcation is between subjects 3 and 4, and the interval, as may be seen, is sufficiently large and uniform for the purpose stated above. Subject 3 read on the average over a third more words than subject 4.

In order to estimate what effect marked differences in subject matter and style might have, seven passages of a considerable range of difficulty and general character were also given as a test to a class of 41 students. The general result has already been indicated. As the purpose was simply to test the validity of the method of selection of the subjects for the laboratory experiments, they will not be further discussed. The results of a third test may, however, be of sufficient general value. The subjects were graduate students of very different interests; (x) a mathematician, (y) a teacher in secondary schools, (z) a psychologist. They were asked to read at their leisure carefully and for information, but in the way and method which they would ordinarily follow, several passages of considerable length and completeness, which were selected with a view to differences in subject matter. The tests were carried out under much more uniform conditions than is possible in a general class test. The passages were selected from the following books and chapters: 1. Carlyle's 'Essay on Voltaire'; 2. Darwin's 'Animals and Plants under Domestication,' Chap. on Inheritance; 3. Peabson's 'Grammar of Science,' Chap. on Matter; 4. Murray's 'Psychology,' Chap. on Perception; 5. Scott's 'Talisman,' narrative passage; 6. Byron's 'Childe Harold,' Canto 1; 7. Boswell's 'Life of Johnson.'

The subjects are denoted by x, y, z; the order or rank of passages in general interest to the different readers is denoted by A-G, A denoting the most interesting passage for that subject. None of the passages were familiar to the subjects with the excep-

tion of that from the "Talisman." The times are in minutes and fractions of a minute.

TABLE XVI

Comparison of rate of reading in various kinds of styles and subject matter

Subjects	Carlyle	Darwin	Pearson	Murray	Scott	Byron	Boswell
	1	2	3	4	5	6	7
x	17* C	10.5 D	19 E	13 G	12 A	4 B	20 F
y	25.5 B	25.5 C	26 A	18 F	33.5 D
z	28 C	35.6 B	42 A	24 D	20 E	8 F	48 G

*Minutes and fractions of a minute.

The conclusion which seems warranted by the above data is that one who reads rapidly in a given style and class of subject matter, will read somewhat proportionately faster than a slow reader whatever within certain recognized limits the nature of the style and subject matter. We are, therefore, it seems, justified in treating the extremes of the above group of thirty as two separate classes, i. e., rapid readers, and slow readers.

It has already been indicated that the short text-line favors the formation of motor habits, and that the fast readers attain to this method more readily than slow readers. The evidence would further seem to show that the acquirement of a rhythmical succession of movements is one of the means by which the fast reader attains to his greater speed in reading.

This fact is well illustrated by the distribution of time in the pauses of records 73 A and 73 B, Chart XXIII, and the somewhat more regular alternation of the number of movements in 73 B. The subject read the passage first in his usual way, (73 A). On the second reading he was asked to read as rapidly as possible consistent with getting the sense. The charts follow:

CHART XXIII

SPEED TESTS

No. 73 A

A. Usual Rate of Reading

1	Even athletic[s ar]e not wa[nt]ing in this eas[ter]n univ[er]sity). The	4
2	at[hle]tic club consists of seven se[ct]ions—row[ing], tra[ck] athletic[s, base-	7
3	ball, footbal[l, la]wn ten[ni]s, swim[m]ing, Judo (a kin[d of wrestling),	5
4	fenc[ing] and arch[er]y. In the [spr]ing, when[] the rosy cl[ou]d of[] cherry	6
5	blossom[s covers the bank] of the Ri[ver] Sumida, the[r]owing cl[ub h]olds	6
6	a re[gatta]. In the autu[mn], the athletic s[ect]ion hold[s a meeting[in] the	5
7	recrea[ti]o[n ground of th]e university. [R]unning, jum[ping, hurd]le [ra]ces,	6

Av., 5.5

Total number of fixation pauses, 39; total duration, 8,392.1σ; average duration, 215.2σ; median, 199.8σ, A. D., 54.3. Length of text line, 107.5 mm. Height of type, 1.5 mm.

CHART XXIII

No. 73 B

B. Most Rapid Rate of Reading

2	Even athletics are [no]t wanting in this eastern univ[er]sity. The	3
2	athletic [cl]ub consists of[] seven sections—row[ing], [t]rack athlet[ics, ba]se-	5
3	ball, football, l[awn] tennis, swimmi[ng,]Judo (a kind[of w]restling),	3
4	[f]encing and arch[er]y. I[n] the spring, when the[] rosy cloud o[f cher]ry	4
5	blossom[s covers the bank of the Riv[er] Sumida, the row[ing] club h[olds]	4
6	a regatta. In the a[utu]mn, the athletic section[] holds a meetin[g in] the	3
7	recrea[ti]o[n ground of the university]. Running, [j]umping, hurdle [ra]ces,	4
8	etc.(, la[st] t[h]e whole afternoon, and[the] scene is as ani[ma]ted as eve[n]	5
9	[a] Yale-Princeton 'rooter' cou[ld] wish; the[slo]ping hillside[] of the arena-	5
10	like [gr]ou[nd] is filled with cheering crowd[s,]and the mingl[ing] of cos[-]	4
11	[]tunes, color[s and gestures] add to the anima[ti]on of the scen[e].)In the	6
12	matte[r of suppleme[n]tal athletics, we ma[y] note that swimmi[ng] is given	4

Total number of fixations, 50; total duration, 9,967.5σ; average duration, 199.3σ; Median, 190; A. D., 51.3.

It is interesting in the first place to note that the subject believed introspectively that the attempt to secure an increase in the rapidity of reading was quite unsuccessful. "The idea of reading the passage rapidly seemed a hindrance rather than a help." The subject believed that he generally read at his maximum rate and thought this was particularly true in the first reading of this passage, as it was a much more interesting passage than the passage that had preceded it.

The records show, however, that the subject's introspection was very inaccurate; not only was the absolute time of nearly every pause diminished, but fewer pauses were made, and the average distance of the eye's first pause from the left edge of the page noticeably increased. The saving in time in the first seven lines amounts to 3189σ , or nearly one-third of the total time. The number of pauses is reduced from 39 to 26 or one-third. The acceleration was, therefore, due as much to the increase of the span of attention as to a decrease of the length of time of the stops.

The most important characteristic, however, and the point of present discussion is the difference in the mode of distribution of the times of fixation. There is a decrease in the average duration of the pauses in the second reading, *but this decrease is not made equally in all parts of the line. It occurs chiefly in the last half of the line, and in fact not only is the time of the first fixations not decreased on the second reading, but there is a slight increase in both the average and total time spent in the initial fixations.* The total duration of the first fixations in lines one to seven inclusive is 1702.8σ in the first reading and 1761.3σ in the second. The distribution in Table XVII is given in the average length of time spent in (1), first fixations; (2), in second fixations, etc., of the passages.

TABLE XVII

Distribution of the average duration of all the first, second, third, etc., fixations in two readings of the same passage, 73 A being read in the usual way, 73 B being read as rapidly as possible

Records	Av. No. of Fix. Per Line	A. D.	Av. Duration of Fix. Per Passage, A. D.		Av. of 1st Fix.	Av. of 2d Fix.	Av. of 3d Fix.	Av. of 4th Fix.	Av. of 5th Fix.	Av. of 6th Fix.	Av. of 7th Fix.
73A	5.5	.76	215.2	54.3	243.2	226.9	211.6	250	201.9	152.6	178.2
73B	3.7	.61	199.3	51.3	249.9	197.4	198.7	196.3	150.5	85.1	

In the first reading (73 A) the time of fixation is distributed in each part of the line more equally than in the second reading. But in the latter reading the method of motor functioning is that already described of a long first fixation followed by one or more much shorter fixations, etc. (see above). This result was brought about solely by increasing the speed of reading. It is significant that this same peculiarity is, as already pointed out, also a characteristic of the form of movement principally of those whom the other tests have shown to be rapid readers, and that the slow readers do not ordinarily show this characteristic. The *cause* of the slowness of reading may doubtless be for the most part central, and quite apart from this peculiarity. But it is important to note that this characteristic form of movement is the usual physiological accompaniment in rapid readers, and wanting to a greater or less extent in the slow readers.

To restate the hypothesis which has been proposed in explanation of this fact, "The rapid reader 'distributes his attention more readily at the initial fixation of the line, and is enabled on this account to fall more readily into a uniform habit of movement.'"

It should be added that the observation is not offered as the sole explanation of differences in the rate of reading. An important cause of slow reading may be, for example, the excess of the auditor-motor accompaniment of repressed articulation, etc., which is simply another way of saying that the assimilation processes are slower. The effect of articulating is itself to decrease ordinarily the span of attention, and, therefore, as argued, make the duration of all pauses more uniform.

On the other hand, the experiments indicate that there is a chance for improvement in the rate of reading. A habit of slow methodical plodding is often easily fallen into which varies little whatever the sort and importance of the reading, but which allots to whatever is read, if it is of ordinary difficulty, about the same amount of time and attention, line by line and sentence by sentence. It often seems, for example, that the careful dwelling upon each word and phrase, which is the daily method of the classical student throughout many years of study, helps not a little in fixing such a habit of slow assimilation. Long continuous application, in which the attention remains uniformly of a medium intensity, is seldom alert and selective, or never reaches its highest pitch or its lowest, is little suited to the formation of a habit of attention adapted to an age of newspapers and magazines and ephemeral books. What may be called speed tests ought on this account to have some place in school methods of teaching reading as well as in other subjects in which a selective character and alertness of attention is demanded and cultivated.

To summarize the facts that have been brought out in this and previous sections,—rapidity of reading is not necessarily correlated with regularity of movement and steadiness or preciseness of fixation. Some of the fastest and slowest readers were found equally regular in movement. A wider ‘spanning’ of attention,—as denoted both by the greater frequency of long pauses at the beginning of the line, and by fewer fixations per line,—is characteristic of the more rapid readers. *The slow readers have a narrower span or working extent of attention, and a greater total arc of movement.* This may best be seen by comparing the extreme fixation points in reading the lines in Chart II. Finally, quickness of reading seems to be closely associated with the formation of motor habits.

CHAPTER XIV

THE FATIGUE OF THE EYES IN READING

It has been possible to study the question of visual fatigue in this investigation only in connection with the general problem of the characteristics of the eye's movement in reading. It has been tested, however, under two different experimental conditions. In each the assumption is made that the presence of fatigue may be indicated by a decline in the velocity of movement.

The first method employed for testing this effect of fatigue was to secure a record of reading late at night after the subject had used his eyes steadily for a long period. The experiment was carried out completely with but one subject. The records were in this case taken between 10:30 and 11:00 P. M., after the subject had spent fourteen hours in study, between six and seven of which were spent in proof reading. The proof reading was done in the laboratory, and the subject simply brought in a clipping from his galley of proof, took his place before the camera, which had been previously adjusted, and read, at least as far as introspection or observation could show, in exactly the same way that the reading had been done during the preceding hour. The subject had also been reading proof for several days preceding, having read on the previous day for about eight hours. He was also tested on other reading matter. These records were then compared with similar records which had been made a week previous and in the day-time. Records were also taken when the subject was fresh on the following morning. The conditions seemed to be very favorable for detecting evidence of fatigue, provided it were present and exerted any influence upon the rapidity of movement or upon the duration of the fixation pauses.

The results are as follows: The passage was first read (34 B) at 10:30 P. M., after the previous work described. It was then re-read (35 A) the next morning, when the subject was fresh and before any regular study had begun. Record 34 B, total time for six lines, 12,944 σ ; average, 287.64 σ ; number of fixations, 45; similarly, Record 35 A, total time, 11,441 σ ; average, 243.42 σ ; number of fixations, 47. The passage is, therefore, read in the morning with a saving of 1,503 σ . If this record stood by itself, it might seem that the shorter time was due to general familiarity with the

passage from the first reading, although proof would naturally be read somewhat more uniformly than ordinary narration. However, this possible criticism is removed in the next record, where the practice effect, if any, would tend to conceal the effect of fatigue.

The results for other pages are as follows: Record 14 A, 'Evolutionary study,' etc., first nine lines, total time, 11,811.4 σ ; 49 fixations; average duration, 241 σ , A. D. 67.3; Record 32 A, read five days later at 10:30 P. M. in experiment for fatigue, total time, 12,482 σ ; 52 fixations; average duration (for 54 fixations), 241.8 σ , A. D. 70.9. The latter reading, therefore, took 670.6 σ longer and three more fixations. The average times were practically the same. Any familiarity with the passage that remained after the interval of five days would have the effect of decreasing the duration and number of pauses. The increase, therefore, is the more noticeable.¹

Record 13b, 'St. Petersburg,' etc., second reading by H (fifteen lines), total time, 13,000 σ ; 60 fixations; average duration (for 63 pauses), 216 σ , A. D., 50; 32 B^F, read five days later between 10:30 and 11:00 P. M., total time, 16,620 σ ; 60 fixations; average duration, 277.2 σ , A. D., 64.1. Loss, 3,630 σ . Record 33 A was read immediately after 32 B^F. The subject was instructed to articulate the words. A comparison of the record with a similar one (with articulation), made the next morning at about 10 o'clock, shows again that the evening performance was much slower. The familiarity secured from repeated readings would perhaps be about the same in this case, 33 A having been the second consecutive reading, whereas, although 36 A was the third reading, it was made after an interval of nearly twelve hours. The results are:

Record 33 A (fatigue), total time for nine lines, 11,070.6 σ ; number fixations, 51; average, 217.1 σ , A. D., 76.7. Record 36 A, total time for nine lines, 10,040 σ ; number fixations, 41; average, 244.87 σ . The record of the morning hour was, therefore, read in 1,030.6 σ less than that of the evening previous.

Although the experiments were made with but one subject, the results seem sufficiently constant to warrant their presentation. For more convenient reference the results are brought together in Table XVIII.

¹ Especially is this true as on the first day the passage was read four times in succession. The record here given of 14A was the first of these readings, but the other readings must have given some familiarity which would tend to make even five days later the passage less difficult of reading, and conceal the effect of fatigue. An exactly similar condition was true in the next records, two other readings having been made on the same day and after 13b.

TABLE XVIII

Comparison of readings, (1) under normal conditions, (2) when fatigued

	No. of Record	No. of Fixations	Total Time σ	Av. σ	A. D.	Loss in Time in F. σ
Normal.....	14A	49	11811	241	67.3	
Fatigue.....	32A	52	12482	241.8	70.9	670
Normal.....	13B	60	13000	216	50	
Fatigue.....	32B	60	16630	277.2	64.1	3620
Normal.....	36A	41	10040	244.8
Fatigue.....	33A	51	11070	217.1	76.7	1030.
Normal.....	35A	47	12944	287.6
Fatigue.....	34B	45	11441	243.4	1503

The second method was to measure and compare the times or duration of the eye's movement, (1) when reading the long lines of print, and (2) when reading the same subject matter in short lines. Because of the longer times and their greater uniformity, the return sweeps from the end of one line to the beginning of the next were selected for measurement instead of the more variable interfixation movements. Here, again, the assumption is that fatigue would be evidenced by difference in the rate of movement. Four records of two subjects were chosen at random for comparison. The subject matter, type, etc., was the same in each reading; the only change being that the lines in one case were on the average just twice the length of the other passage. The results are presented in Table XIX.

The first column gives the number of the return movement (although not the same movement for each subject); the second and third columns the extent of the movement in millimeters of the distance on the page as read; the fourth and fifth the duration of the movement; and the sixth and seventh columns the average time taken to move the eye across 1 mm. of the page. Table XIX A gives the times for the long lines. Table B for the short lines.

TABLE XIX A

Rate of movement of eye in the return sweeps of a long line. Records 68 A and 59 A

No. of Mt.	Extent of Mt. in MM.		Duration of Mt. in σ		Time for 1 MM. of Mt. (in σ)	
	S	E	S	E	S	E
1	169	142.5	103	130	.61	.91
2	174	140	132	126	.76	.90
3	153	142	122	138	.80	.97
4	163	147	145	176	.89	1.19
5	169	150.5	146	215	.86	1.43
6	160	142	154	208	.96	1.39
7	150	14597

TABLE XIX B

Short line arrangement

No. of Mt.	Extent of Mt. in MM.		Duration of Mt. (in σ)		Time for 1 MM of Mt. (in σ)	
	S	E	S	E	S	E
1	68	74	110	79	1.62	1.07
2	63	67	103	91	1.63	1.36
3	71	64	98	106	1.38	1.64
4	64	76	79	108	1.23	1.63
5	68	58	109	67	1.60	1.15
6	68	68	117	75	1.72	1.10
7	48	72	80	88	1.66	1.22
8	62	67	101	80	1.69	1.19
9	68	62	120	108	1.76	1.72
10	76	71	135	74	1.77	1.04
11	75	82	92	97	1.23	1.19
12	74	69	130	126	1.75	1.81
13	58	...	99	1.70

A reference to the times given in the last two columns of Table XIX A discloses a rather surprising fact; namely, that with two exceptions every movement in the case of each subject is longer than that which preceded it. The average duration of a movement—to state the fact in another way—in the case of the first three movements is for one subject nearly a third shorter than that of the last three movements, and for the other subject about a fourth shorter.¹ This evidence of the presence of fatigue in the long line, if the progressive retardation of movement may be so interpreted, is, as an examination of Table B will show, *not found in the short line arrangement*. Although there is considerable variation, and in some parts of the records of each subject a succession of a few numbers of increasing duration, the average of the last six movements is but slightly longer than that of the first six, one-fifteenth in one case and one-forty-fourth in the other, i. e., very much less than the probable error. The evidence, therefore, points against the conclusion of Landolt and others that movements through a small angle are very fatiguing. Although both of these movements are of considerable extent,—it is the movements through the larger angle which cause the muscular retardation. The phenomenon is peculiar and unexpected, when consideration is made of the large number of reading movements made in a single hour. For evidently if the retardation continuously progressed at the above rate, the eyes would have ceased moving before an

¹ A similar fact has already been noted by Prof. Dodge, (*Angle Velocity of Eye Movements, Psychological Review*, VIII, p. 155) in the duration of long changes in the line of regard. "The last four movements in a series of ten always averaged longer than the first four."

hour was over. A study of several other records would tend to show that this increase of time is but a more marked instance of what occurs in a much less degree in the short lines. After a short succession of movements of decreasing rate, a fresh start is taken with a return to the normal or to an accelerated velocity of movement. This evidently is repeated somewhat as in the familiar fatigue curves of other muscles. The interesting fact is, however, that the decline in rapidity should be of such a marked character, since the recovery must in that case occur so much more frequently.

The phenomenon is certainly worthy of further study. That it is most marked in the case of the long line doubtless indicates the undesirability of this length of text line. Incidentally the records of Table XIX also show the relation between the absolute rapidity of movement in long and short lines. The angle velocity is, as was to be expected, greater in the longer sweeps. The difference, of course, is insignificant and negligible, when one is comparing total times spent in reading these different lengths of text line (as above) and has, therefore, not been taken into account.

CHAPTER XV

SUMMARY AND CONCLUSIONS

1. The movements of the eyes in reading are found by means of photographic registration to be composed of a succession of distinct pauses or fixations and connecting movements. The fixations are the periods of peripheral stimulation and perception, and have been on this account the principal object of study.

2. The average number of fixations per newspaper line varied among the eight adult subjects experimented upon from 3. to 7.1, or an average of from 1.9 words to 1.0 words per fixation. In a line of not quite double this length from 7.5 to 9.4 fixations were made, averaging from 1.5 to 1.09 words per fixation. The results of other passages were similar.

3. The number of fixation pauses to the line is dependent on a variety of factors, which are themselves by no means constant.

The amount read per fixation is seldom equal to the extent of the field of perception. It is roughly correlated to individual differences in the rates of reading, fewer pauses being made by the more rapid readers. Constancy in the number of pauses for a group of lines, regardless of at least small differences of subject-matter and form, gives evidence of the formation of motor habits.

4. A motor habit is evidenced by a rhythmical series of the same number of pauses per line, and by a uniform method of time distribution. The latter consists of a comparatively long initial pause followed by two or more shorter ones of decreasing duration. These may be followed by a somewhat longer pause near the end of the line. These motor habits are most easily acquired in the shorter lines, and aid materially in the rapidity of reading. They are further one of the characteristics of rapid readers.

5. Inaccuracies of motor innervation or of the functioning of the eye muscles are in evidence here as in other types of eye movement. With these are to be classed the refixations proper which are peculiar to the reading process. Refixations occur chiefly at the beginning of the line, and most frequently in the first or second line of a passage. They are in these cases due to the inaccuracy of peripheral perception and motor adjustment due to false estimation of linear magnitude. An experiment made by varying the length of the return movement by means of the indentation

of every other line within the margin showed, it is believed, that after the first or possibly second horizontal movement, the resident muscular sensations of angular displacement govern the extent of movement of the succeeding return sweep. This is the basis of the motor habit. In the first line, sometimes in the second line, before a motor adjustment has been made, it is necessary to depend solely on the peripheral local signs. The longer the line the more inexact these will naturally be; the result is that the inaccuracies of over and underestimation are much more frequent in the long lines than in the short lines. The experiment shows the advisability of short lines of uniform length. A requisite of an automatic movement is uniformity of conditions. Inaccuracy of movement and the necessity of refixation must ordinarily be a hindrance to the rapidity of perception.

The larger number of refixations at the beginning of a passage is due to the fact that the motor impulse is in the process of adjustment. Normally the extent of movements of the eye tends to become uniform due to the formation of motor habits of reaction. The errors of fixation are due in part to the subversion of these motor tendencies. The difficulties of accurate fixations may be increased by too frequent change of the arc of movement. Refixations are found in the case of three subjects in 21.6 per cent., 69 per cent., and 80 per cent., respectively, of the return movements in the longest line, and in but 11 per cent., 18 per cent., and 18 per cent. in the short lines for the same subjects; 21 per cent. of these are in the first line.

6. There is a wide difference among persons in the way in which they move their eyes in reading. The movements of some are very regular and the fixations precise and relatively 'steady'; in the case of others, fixation and movement are at times almost indistinguishable, i. e., the eye passes over a considerable part of the line by a movement that is very much slower than the inter-fixation movement.

These slow changes of the point of regard are, however, to be classed as fixations because perception may take place during their progress. It is suggested that this difference of 'poise' among the fixations themselves may depend on differences in the rate at which the subject matter lying on the periphery gains the center of consciousness. The shifting is due to the muscular tension following upon the separation of fixation and attention. It is argued that these changes or fluctuations of the attention ordinarily take place from one word group or syllable to another, and are evidenced and accompanied either by the usual interfixation movement, or by the above described shifting movements. That there is no similar ten-

sion or movements of the eye muscles in tachistoscopic reading, goes to show that there is no fluctuation of attention during or after the exposure. The assimilation of the memory (not clear) image must be successive as in ordinary reading. But it is a succession not of letters, whether 'domineering' or other, but a succession of syllables and words. The perception at each fixation pause is unitary and simultaneous.

7. The hypothesis of lack of perception during movement proposed by Erdmann and Dodge as an explanation of the need and existence of fixation pauses, and since supported by experimental evidence by the latter of these writers, has been further substantiated by a measurement of the duration of the true interfixation movement. The rapidity of these movements is ordinarily sufficient to cause fusion of stimuli, and hence lack of perception.

8. The duration of the fixation pauses for four subjects in simple newspaper reading (the same passage being read by all) was found to vary from an average of 160.8 σ to 401.9 σ , and averaging from 3.7 to 7. fixations per line. There is a tendency for the slow reader to make both more pauses and longer pauses. The initial pause is usually the longest in the line. This is believed to be due to a wider spanning of the attention at the beginning of the line.

9. The attention 'span' and the extent of fixation in the reading of numbers was limited in my subjects to one or two digits. This is due to the fact that except in the case of familiar dates as of the current year, etc., we seldom meet with the same combination of numbers. For this reason a group of numbers does not become a 'Gasamtbild' as in the case of words, whose elements are relatively fixed. It is further found that these minute changes of the attention from one digit to another are accompanied by similarly minute changes of fixation, and it is held that, if such changes and fluctuations of the attention, as are supposed by Zeitler and Messmer in the reading of letters and domineering complexes of words, actually took place, we should expect to find some such indication in the characteristics of the fixation pauses. The absence of such indications argues that words are usually perceived simultaneously as wholes and not successively by letters.

10. As regards the location in the line of the points of fixation, it is found that the first and last fixations generally fall within the edges of the line, i. e., at a little distance from its beginning and end. This is true in less degree for the slow readers and in general for readers of small or contracted attention span. It is further dependent upon the character of the end words of the line. The exact object of fixation is significant only as representing the point about which are grouped the 'block' of letters that are simulta-

neously perceived as one word or phrase complex. It more often falls in the first third than at the center of a given perception area. A new fixation is made for each unit of perception. The area covered by a given fixation depends on the size or extent of the perception unit. It is large in the case of nouns, and adjectives, and verbs, and usually small in the case of the connective parts of speech, the conjunctions and prepositional phrases, the relative pronouns, and the auxiliary verbs. Letters and words frequently and regularly found together tend to be formed by long association into one complex whole for which certain elements are then selected as cues. Adjectives and nouns that frequently stand together, or for which the general context has prepared the reader, will be read in one unitary perception. So with many phrases. When words are not regularly associated into a single unchanging group, but appear now with one word and now with another, these words, unless helped out by immediate context, must be perceived separately. This principle has already been illustrated in the case of numbers.

11. This general law is further illustrated in proof reading, reading a foreign language, reading aloud, and in reading by near and far accommodation. As shown in the reading at far accommodation, it is not the mere extent of words which can be easily seen which determines the span of attention or the number of fixation pauses. In the first three cases, i. e., proof reading, etc., the attention must be given to smaller units, with the result that the number of pauses is increased.

12. The readings of three children, nine to eleven years of age, illustrate the development of unitary word perception. The frequency of fixation pauses shows the innervation to be much more divided in the case of the youngest subject (boy of nine years of age). The more purely physiological difficulties have been largely mastered at this age.

13. The length of the text lines is mainly important in its effect upon the formation of motor habits. The rate of reading depends in part on the ease with which a regular rhythmical movement is established. The peculiarities of this movement are, as noted, two,—a succession of the same number of pauses per line, and a distribution of the duration of the pauses, in which the first pause of a line is uniformly longer than the succeeding pauses followed, in some cases, by a second increase near the end of the line. Those lines are best suited to rapid reading which give opportunity for a wide span of attention, but which are not of such length that the peripheral perceptions from the end or beginning of a line are too inexact and confused to be of value in determining the general character of a large part of the line. If the lines are too long the

incidental concurrent impression of words lying in the lines above and below, and, in fact, the general characteristics of those lines, are not infrequently distracting. These concurrent impressions are doubtless often a distinct advantage in reading short lines, since the matter lying above and below the point of regard is then more closely connected in sense with the immediate object of attention. Uniformity of length of line is a requisite for the formation of motor habits of reaction.

14. 'Speed' tests in reading further illustrate the fact that increased speed of reading is attained by means of the above described characteristic motor reaction. Fast and slow readers are most clearly differentiated by the failure of the latter to acquire this mode of movement. The rapid reader distributes his attention more readily, especially at the initial fixation of the line, and is enabled on this account to fall more readily into a uniform habit of movement. The slow reader has a narrower span or working extent of attention. This may be simply (in addition to longer pauses) another evidence of slower perception and assimilation processes. Steadiness and precision of fixation are not correlated with the rate of reading.

15. The presence of fatigue in the eye muscles is indicated,—(1) by a slower rate of reading after prolonged study and reading, and (2) by a progressive decrease in the velocity of movement especially noticeable in the long lines.

APPENDIX

For the purpose of more exact comparison which may be desirable in subsequent studies, I have had printed on this and the following page the first line or two of each of the various passages used for experiment. They are set up in the same size, style and arrangement of type as that of the original passages. The page of indented lines read in the experiment on 'Refixations' is printed in full. All other pages than those given below were typewritten. The last two lines of the appendix illustrate closely the style of type, amount of spacing, etc., of the typewritten pages, and the lengths of the typewritten lines have in each case been stated in the text.

ST. PETERSBURG, Nov. 2.—The Admiralty has telegraphed to the officers of the Baltic fleet, who were left behind at Vigo in order that they might testify, and who were on their way to St. Petersburg, to remain in Paris.

II. A license for promotion may be issued to the holder of a teacher's license No. 1 who has had experience rated as equivalent to three years of New York city public school teaching (including one

Summary.

Evolutionary study and thought have been hindered by the confusion of two unrelated biological phenomena, (1) evolutionary progress or vital motion, and (2) the origination or multiplication of species.

Even athletics are not wanting in this eastern university. The athletic club consists of seven sections—rowing, track athletics, base ball, football, lawn tennis, swimming, Judo (a kind of wrestling),

King Midas thought, and thought. At last he looked at the stranger and said, "I wish that everything that I touched may turn to gold."

And this old savage was in the right, for, as I understood since by other hands, the savages of that part never attempted to go over to the island

But the dark objects were not cattle. They were the Black Douglas and his men, creeping on hands and feet toward the foot of the castle wall. Some

And this old savage was in the right, for, as I understood since by other hands the savages of that part never attempted to go over to the island afterwards. They were so terrified

The boatswain was killed upon the spot; the next man was shot in the body, and fell just by him, though he did not die until an hour or two after; and the third ran for it. At the noise of the fire, I immediately advanced with my whole army, which was now eight men; viz. myself, generalissimo; Friday, my lieutenant-general; the captain and his two men, and the three prisoners of war, whom he had trusted with arms. We came upon them indeed in the dark, so that they could not see our number;

The gorgeously costumed imperial plenipotentiary suffered excruciating anguish at the recollection of his personal thoughtlessness and carelessness. There lay before him the recently appointed ambassador but now

ACKNOWLEDGEMENTS

This investigation was conducted in the Psychological Laboratory of Columbia University during the college year 1904-1905. Every facility of the laboratory was most generously placed at my disposal. For these courtesies and for much kindly criticism and interest in the experiments, I am indebted to Prof. J. McKeen Cattell and to Prof. R. S. Woodworth. I desire also to express my thanks and obligations to Prof. Edward L. Thorndike of Teachers' College, and to Prof. Raymond Dodge of Wesleyan University. Prof. Thorndike has taken part in the experiments, and given much valuable assistance in the measurement of the records and in the class tests. I am indebted to Prof. Dodge for whatever knowledge I may have secured of the technique and methods of the experiments. My thanks are also due to those who have acted as subjects, Mr. Vivian A. C. Henmon, fellow in psychology; Mr. G. C. Fracker, assistant in the department of psychology; Miss J. R. Seibert, assistant in psychology at Teachers' College; Mr. M. A. Martin, scholar in psychology; Mr. George D. Strayer and Mr. Edward C. Elliott, fellows of Teachers' College; and Mr. Smith, mechanic to the laboratory. Mr. Henmon has taken part in nearly every division of the investigation and served as subject in the trying fatigue tests. Miss Seibert has also assisted with the utmost patience and accuracy in the tedious measurement of a considerable number of the records and in the tabulation of results. I am also indebted to Miss Amy Schüssler, principal of the Speyer School, for help in the study of children's reading, and to Dr. F. Kuhlmann, of the University of Wisconsin, who has kindly read the proofs.



VITA

The author of this monograph was born in Marblehead, Mass., in 1878. He received his early education in the Boston Public Schools and in Phillips Exeter Academy, and was graduated from the latter institution in 1896. He received the degree of Bachelor of Arts from Wesleyan University in 1900 and the degree of Master of Arts in 1903. He was a graduate student of Wesleyan University, 1900-1901; vice-principal and teacher of Latin and Greek at the Middletown (Conn.) High School, 1901-1903; student at the University of Göttingen, summer semester, 1904, and student and Fellow of Teachers College, Columbia University, 1903-1905.







ONE MONTH USE
PLEASE RETURN TO DESK
FROM WHICH BORROWED
**EDUCATION-PSYCHOLOGY
LIBRARY**

Y

This book is due on the last date stamped below, or
on the date to which renewed.

DW.

1-month loans may be renewed by calling **642-4209**
Renewals and recharges may be made 4 days prior
to due date.

ALL BOOKS ARE SUBJECT TO RECALL 7 DAYS
AFTER DATE CHECKED OUT.

DE		
JU	NOV 4	1976
JUL	DEC 1	
JUL	DEC 1	REC'D -9 AM
JU		
J		
DE		
A		
MAF		
AI		

LD 21

LD 21A-30m-5,'75
(S5877L)

General Library
University of California
Berkeley

188859

BF456

R2D4.

Educ. Dept.

UNIVERSITY OF CALIFORNIA LIBRARY

