

UNIVERSITY OF TORONTO

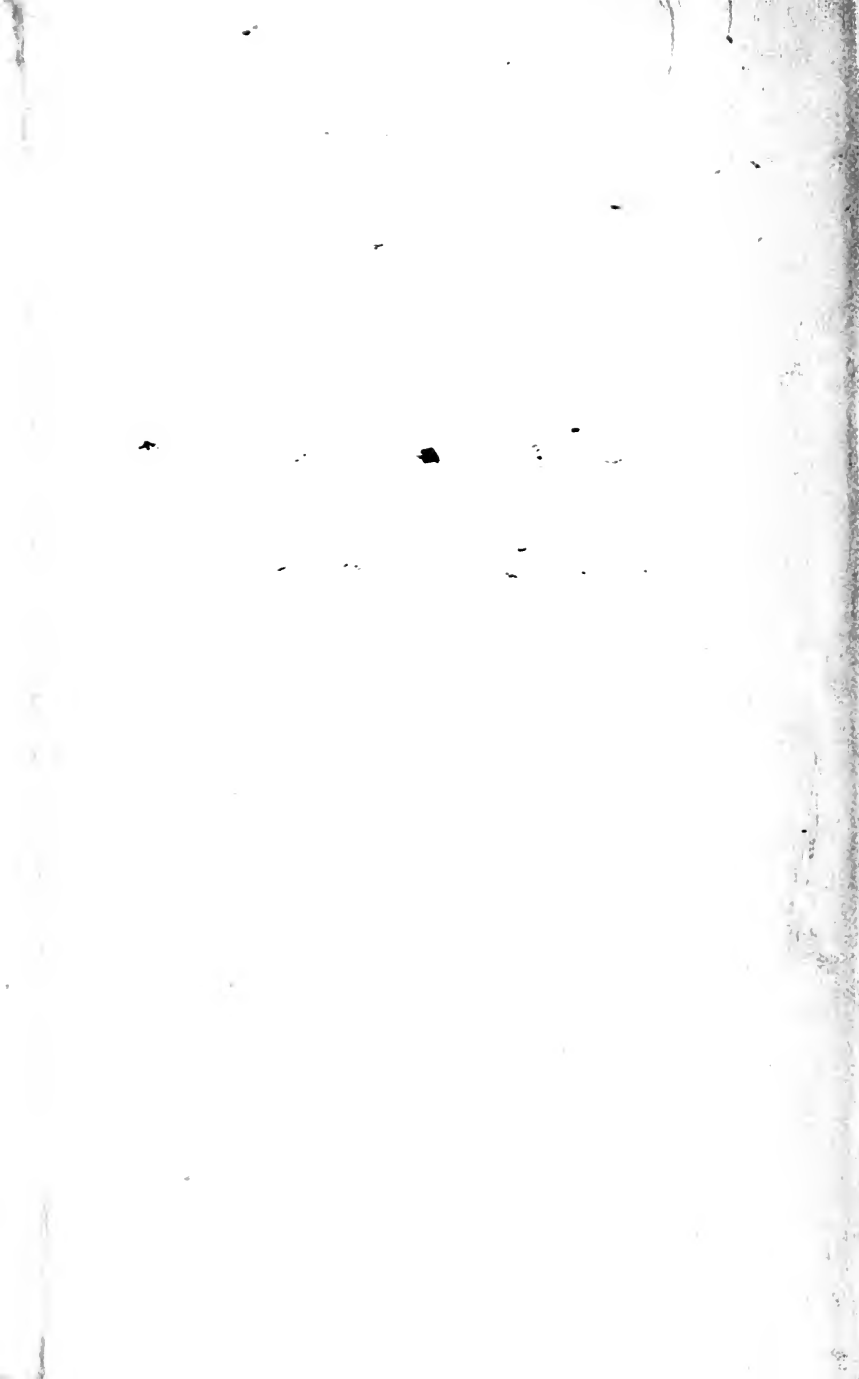

3 1761 00056480 7



~~INDEX~~ LIST JUL 15 1926

U.C.

I

Digitized by the Internet Archive
in 2007 with funding from
Microsoft Corporation

Psych.
W912 P16

PSYCHOLOGY

A STUDY OF MENTAL LIFE

BY

ROBERT S. WOODWORTH, Ph.D.
Professor of Psychology in Columbia University



169391
15.2.22.

NEW YORK
HENRY HOLT AND COMPANY

1921

BF
131
W865

COPYRIGHT, 1921
BY
HENRY HOLT AND COMPANY

PRINTED IN THE U. S. A.

141

PREFACE

A few words to the reader are in order. In the first place, something like an apology is due for the free way in which the author has drawn upon the original work of many fellow-psychologists, without any mention of their names. This is practically unavoidable in a book intended for the beginner, but the reader may well be informed of the fact, and cautioned not to credit the content of the book to the writer of it. The author's task has been that of selecting from the large mass of psychological information now available, much of it new, whatever seemed most suitable for introducing the subject to the reader. The book aims to represent the present state of a very active science.

Should the book appear unduly long in prospect, the longest and most detailed chapter, that on Sensation, might perfectly well be omitted, on the first reading, without appreciably disturbing the continuity of the rest.

On the other hand should any reader desire to make this text the basis of a more extensive course of reading, the lists of references appended to the several chapters will prove of service. The books and articles there cited will be found interesting and not too technical in style.

Much advantage can be derived from the use of the "Exercises". The text, at the best, but provides raw material. Each student's finished product must be of his own making. The exercises afford opportunity for the student to work over the material and make it his own.

A first or preliminary edition of this book, in mimeographed sheets, was in use for two years in introductory classes con-

ducted by the author and his colleagues, and was subjected to exceedingly helpful criticism from both teachers and students. The revision of that earlier edition into the present form has been very much of a coöperative enterprise, and so many have coöperated that room could scarcely be found for all their names. Professor A. T. Poffenberger, Dr. Clara F. Chassell, Dr. Georgina I. Gates, Mr. Gardner Murphy, Mr. Harold E. Jones and Mr. Paul S. Achilles have given me the advantage of their class-room experience with the mimeographed book. Dr. Christine Ladd-Franklin has very carefully gone over with me the passages dealing with color vision and with reasoning. Miss Elizabeth T. Sullivan, Miss Anna B. Copeland, Miss Helen Harper and Dr. A. H. Martin have been of great assistance in the final stages of the work. Important suggestions have come also from several other universities, where the mimeographed book was inspected.

R. S. W.

COLUMBIA UNIVERSITY

August, 1921

CONTENTS

CHAPTER I

	PAGE
WHAT PSYCHOLOGY IS AND DOES.....	1
Varieties of Psychology.....	2
Psychology as Related to Other Sciences.....	5
The Science of Consciousness.....	7
The Science of Behavior.....	8
Introspection	10
Objective Observation.....	11
General Lines of Psychological Investigation.....	14
Summary and Attempt at a Definition.....	17
Exercises	19
References	20

CHAPTER II

REACTIONS	21
The Reaction Time Experiment.....	22
Reflex Action	24
The Nerves in Reflex Action.....	26
Internal Construction of the Nerves and Nerve Centers.....	31
The Synapse	34
Coördination	37
Reactions in General.....	39
Exercises	42
References	44

CHAPTER III

REACTIONS OF DIFFERENT LEVELS.....	45
Different Sorts of Stimuli.....	47
The Motor Centers, Lower and Higher.....	49
How the Brain Produces Muscular Movements.....	53
Facilitation and Inhibition.....	54
Super-motor Centers in the Cortex.....	55
Speech Centers.....	57
The Auditory Centers.....	59
The Visual Centers.....	62
Cortical Centers for the Other Senses.....	63
Lower Sensory Centers.....	64
The Cerebellum.....	65
Different Levels of Reaction.....	65
Exercises	67
References	67

CONTENTS

CHAPTER IV

	PAGE
TENDENCIES TO REACTION.....	68
Purposive Behavior.....	70
Organic States that Influence Behavior.....	72
Preparation for Action.....	74
Preparatory Reactions.....	77
What the Preparatory Reactions Accomplish.....	79
What a Tendency Is, in Terms of Nerve Action.....	82
Motives.....	84
Exercises.....	86
References.....	88

CHAPTER V

NATIVE AND ACQUIRED TRAITS.....	89
The Source of Native Traits.....	90
Reactions Appearing at Birth Must Be Native.....	91
Reactions That Cannot Be Learned Must Be Native.....	92
Experimental Detection of Native Reactions.....	93
Is Walking Native or Acquired?.....	95
Universality as a Criterion of Native Reactions.....	97
Some Native Traits Are Far from Being Universal.....	98
Why Acquired Traits Differ from One Individual to Another.....	99
What Mental Traits Are Native?.....	100
Exercises.....	103
References.....	104

CHAPTER VI

INSTINCT.....	105
The Difference Between an Instinct and a Reflex.....	107
An Instinct Is a Native Reaction-Tendency.....	109
Fully and Partially Organized Instincts.....	111
Instincts Are Not Ancestral Habits.....	113
Instincts Not Necessarily Useful in the Struggle for Existence.....	114
The So-called Instincts of Self-preservation and of Reproduction.....	115
Exercises.....	117
References.....	117

CHAPTER VII

EMOTION.....	118
Organic States That Are Not Usually Classed as Emotions.....	119
How These Organic States Differ from Regular Emotions.....	120
The Organic State in Anger.....	121
Glandular Responses During Emotion.....	122
The Nerves Concerned in Internal Emotional Response.....	124
The Emotional State as a Preparatory Reaction.....	125
"Expressive Movements," Another Sort of Preparatory Reactions.....	126
Do Sensations of These Various Preparatory Reactions Constitute the Conscious State of Emotion?.....	128
The James-Lange Theory of the Emotions.....	129

CONTENTS

vii

	PAGE
Emotion and Impulse.....	130
Emotion Sometimes Generates Impulse.....	132
Emotion and Instinct.....	134
The Higher Emotions.....	135
Exercises	136
References	136

CHAPTER VIII

INVENTORY OF HUMAN INSTINCTS AND PRIMARY EMOTIONS.....	137
Classification	138
Responses to Organic Needs.....	139
Instinctive Responses to Other Persons.....	145
The Play Instincts.....	151
Exercises	170
References	171

CHAPTER IX

THE FEELINGS	172
Pleasantness and Unpleasantness Are Simple Feelings.....	173
Feeling-tone of Sensations	174
Theories of Feeling.....	175
Sources of Pleasantness and Unpleasantness.....	178
Primary Likes and Dislikes.....	180
Other Proposed Elementary Feelings.....	184
Exercises	186
References	186

CHAPTER X

SENSATION	187
The Sense Organs.....	188
Analysis of Sensations.....	197
The Skin Senses	197
The Sense of Taste.....	201
The Sense of Smell.....	203
Organic Sensations	204
The Sense of Sight.....	204
Simpler Forms of the Color Sense.....	209
Visual Sensations as Related to the Stimulus.....	212
Color Mixing	214
What Are the Elementary Visual Sensations?.....	216
Theories of Color Vision.....	220
Adaptation	224
Rod and Cone Vision.....	226
After-Images	226
Contrast	227
The Sense of Hearing.....	228
Comparison of Sight and Hearing.....	231
Theory of Hearing.....	234
Senses of Bodily Movement.....	236
Exercises	241
References	243

CHAPTER XI

	PAGE
ATTENTION	244
The Stimulus, or What Attracts Attention.....	245
The Motor Reaction in Attention.....	248
The Shifting of Attention.....	251
Laws of Attention and Laws of Reaction in General.....	256
Sustained Attention	257
Distraction	259
Doing Two Things at Once.....	260
The Span of Attention.....	261
Summary of the Laws of Attention.....	262
Attention and Degree of Consciousness.....	265
The Management of Attention.....	267
Theory of Attention.....	268
Exercises	270
References	270

CHAPTER XII

INTELLIGENCE	271
Intelligence Tests	272
Performance Tests	275
Group Testing	276
Some Results of the Intelligence Tests.....	278
Limitations of the Intelligence Tests.....	281
The Correlation of Abilities.....	283
General Factors in Intelligence.....	285
Special Aptitudes	288
Heredity of Intelligence and of Special Aptitudes.....	289
Intelligence and the Brain.....	292
Exercises	294
References	295

CHAPTER XIII

LEARNING AND HABIT FORMATION	296
Acquired Reactions Are Modified Native Reactions.....	297
Acquired Tendencies	299
Animal Learning	302
Summary of Animal Learning.....	310
Human Learning	311
Human Compared with Animal Learning.....	313
Learning by Observation.....	317
The Learning of Complex Practical Performances.....	321
Higher Units and Overlapping.....	323
Moderate Skill Acquired in the Ordinary Day's Work.....	326
Habit	328
Exercises	330
References	331

CHAPTER XIV

MEMORY	332
The Process of Memorizing.....	333

CONTENTS

ix

	PAGE
Economy in Memorizing.....	338
Unintentional Learning	346
Retention	348
Recall	354
Recognition	357
Memory Training	360
Exercises	364
References	365

CHAPTER XV

ASSOCIATION AND MENTAL IMAGERY.....	366
What Can Be Recalled.....	366
Memory Images	368
Limitations of Imagery.....	371
The Question of Non-Sensory Recall.....	373
Hallucinations	375
Free Association	376
Controlled Association	381
Examples of Controlled Association.....	384
Exercises	386
References	388

CHAPTER XVI

THE LAWS OF ASSOCIATION	380
The Law of Exercise.....	389
The Law of Effect.....	391
Limitations of the Law of Exercise.....	393
Association by Similarity.....	395
Association by Contiguity.....	396
The Law of Combination.....	398
The Law of Combination in Recall.....	413
The Laws of Learning in Terms of the Neurones.....	414
Exercises	418
References	418

CHAPTER XVII

PERCEPTION	418
Some Definitions	421
The Difference Between Perception and Sensation.....	423
Perception and Image.....	425
Perception and Motor Reaction.....	427
What Sort of Response, Then, Is Perception?.....	431
Practiced Perception	433
Corrected Perception	435
Sensory Data Serving as Signs of Various Sorts of Fact.....	437
The Perception of Space.....	439
Esthetic Perception	443
Social Perception	444
Errors of Perception	446
Illusions	450
Exercises	460
References	461

CONTENTS

CHAPTER XVIII

	PAGE
REASONING	462
Animal and Human Exploration.....	463
Reasoning Culminates in Inference.....	465
Varieties of Reasoning.....	468
Deductive and Inductive Reasoning.....	474
Psychology and Logic.....	475
Exercises	480
References	480

CHAPTER XIX

IMAGINATION	481
Beginnings of Imagination in the Child.....	482
Preliminary Definition of Imagination.....	483
Play	485
The Play Motives.....	488
Empathy	491
Worry	497
Day Dreams	498
Dreams	499
Freud's Theory of Dreams.....	505
Autistic Thinking	508
Invention and Criticism.....	509
The Enjoyment of Imaginative Art.....	512
The Psychology of Inventive Production.....	517
Imagination Considered in General.....	519
Exercises	521
References	522

CHAPTER XX

WILL	523
Voluntary and Involuntary Action.....	524
Development of Voluntary Control.....	526
Ideomotor Action.....	527
Conflict and Decision.....	528
Obstruction and Effort.....	535
Thought and Action	539
Securing Action	541
The Influence of Suggestion.....	546
Exercises	551
References	551

CHAPTER XXI

PERSONALITY	552
Factors in Personality	553
The Self	555
Integration and Disintegration of the Personality.....	558
The Unconscious, or, the Subconscious Mind.....	561
Unconscious Wishes and Motives.....	565
Exercises	571
References	571
INDEX	573

PSYCHOLOGY

CHAPTER I

WHAT PSYCHOLOGY IS AND DOES

THE SUBJECT-MATTER OF THE SCIENCE, ITS PROBLEMS AND ITS METHODS

Modern psychology is an attempt to bring the methods of scientific investigation, which have proved immensely fruitful in other fields, to bear upon mental life and its problems. The human individual, the main object of study, is so complex an object, that for a long time it seemed doubtful whether there ever could be real science here; but a beginning was made in the nineteenth century, following the lead of biology and physiology, and the work of the investigator has been so successful that to-day there is quite a respectable body of knowledge to assemble under the title of scientific psychology.

Psychology, then, is a science. It is the science of—what shall we say? “The science of the soul”—that is what the name means by derivation and ancient usage. “The science of the mind” has a more modern sound. “The science of consciousness” is more modern still. “The science of behavior” is the most recent attempt at a concise formula.

None of these formulas is wholly satisfactory. Psychology does not like to call itself the science of the soul, for that has a theological tang and suggests problems that have so far not seemed accessible to scientific investigation. Psychology does not like very well to call itself the science

of the mind, as *the* mind seems to imply some thing or machine, and there is no such thing to be observed (unless it be the brain and body generally), and, anyway, psychology is distinctly a study of actions rather than of things. Psychology does not like to limit itself to the study of consciousness, but finds it necessary to study also unconscious actions. As to "behavior", it would be a very suitable term, if only it had not become so closely identified with the "behavioristic movement" in psychology, which urges that consciousness should be entirely left out of psychology, or at least disregarded. "Behavior psychology", as the term would be understood to-day, means a part of the subject and not the whole.¹

The best way of getting a true picture of psychology, and of reaching an adequate definition of its subject-matter, would be to inspect the actual work of psychologists, so as to see what kind of knowledge they are seeking. Such a survey would reveal quite a variety of problems under process of investigation, some of them practical problems, others not directly practical.

VARIETIES OF PSYCHOLOGY

Differential psychology. One line of question that always interests the beginner in psychology is as to how people differ—how different people act under the same circumstances—and why; and if we watch the professional psychologist, we often find him working at just this problem. He tests a great number of individuals to see how they differ, and tries to discover on what factors their differences depend, how far on heredity, how far on environment. The "psychologist" in such a place as the children's court

¹ A series of waggish critics has evolved the following: "First psychology lost its soul, then it lost its mind, then it lost consciousness; it still has behavior, of a kind."

is a specialist whose duty it is to test the delinquent children that are brought before the court, with the special object of measuring the intelligence of each individual child and of helping in other ways to understand the child's peculiar conduct and attitude.

The "psychological examiner" in the Army, during the Great War, had the same general object in view. It was desirable to measure the intelligence of each recruit as he entered the service, since military experience had shown that men of low intelligence made poor soldiers, while those of high intelligence made the best officers and non-commissioned officers, provided they also possessed good physique and certain less measureable mental qualifications, such as courage and leadership.

Applied psychology. The Army psychologists, like the court psychologist, were engaged in applying scientific knowledge to the practical problems of life; and there are many other applications of psychology, to education, to medicine, to business and other occupations, as well as to the art of right living. Scientific knowledge enables you to *predict* and *control*. Having devised scientific tests for intelligence, you can predict of a six-year-old boy who tests low, that he will not get much good from the regular classes in school; and thus you are in a position to control the education of this boy for his own best interests. In the Army, it happened during the earlier part of the war that some companies or regiments made much slower progress in training than others; and a whole Division was delayed for months because of the backwardness of a single regiment. When the psychological tests were introduced, these slow-learning units were found to contain a disproportionate number of men of low intelligence. From that time on, it was possible by aid of the tests to equalize the intelligence of different units when first formed, and thus insure equal

progress in training. This was a good example of "control".

Most of us are attracted by the practical use of a science, and some have no patience with any study that does not seem immediately practical. But really any science, however much it is applied, must remain fundamentally a "pure science"; that is, it must seek most of all to know and understand. Practical scientific knowledge was usually first obtained without any inkling of how it might be used. The science of electricity is the most striking example of this. It began as an attempt to understand certain curious phenomena, which seemed to be nothing but curiosities; yet when the knowledge of these phenomena had progressed to a certain point, abundant use was found for it. Much the same is true of psychology, which began as a pure science and only recently has found ways of applying its discoveries to practical affairs. So the student beginning the science, though properly desirous of making practical use of what he learns, should let himself be governed for the present by the desire to know and understand, confident that the more scientific (which is to say, the more complete, systematic and reliable) his knowledge is, the more available it will be for practical application.

General psychology. Our science is not concerned entirely with differences between people, but asks also in what ways people are alike, and this is indeed its central problem. How do "we" observe, learn, remember, imagine, think? What sensations and feelings do we have, what emotions, what instincts, what natural and acquired impulses to action? How are our natural powers and impulses developed and organized as we grow up? Psychology is concerned with the child as well as the adult, and it is even concerned with the animal. It is concerned with the abnormal as well as the normal human being. So you will find books and

courses on animal psychology, child psychology, abnormal psychology. Now general psychology—or just plain “psychology”—has to do with the main laws and principles that hold in all these special fields.

PSYCHOLOGY AS RELATED TO OTHER SCIENCES

A good definition of our science would distinguish it from other sciences, especially from those neighboring sciences with which it is in closest contact.

Psychology and sociology. There is no difficulty in framing a good logical distinction here. Sociology studies the activities of a group of people taken as a whole, while psychology studies the activities of the individuals. Both might be interested in the same social act, such as an election, but sociology would consider this event as a unit, whereas psychology would break it up into the acts of the several voters. The distinction is clear enough theoretically, but breaks down often in practice, as sociology would like to know the motives that swayed individual voters, while psychology on its side is interested to know what decision was reached by the majority. All the social sciences, including economics and politics, have a psychological side, since they evidently are concerned to know the causes that govern human conduct. Social psychology studies the individual in his social relations.

Psychology and biology. Biology, being the science of living creatures, includes psychology, which studies these creatures on the mental side. The science of life includes the science of mental life. We may call psychology a part of biology, or we may call it one of the biological sciences. It has very close contact with several other branches of biology. Animal psychology overlaps that part of zoölogy which studies the behavior of animals. Genetic psychology, as it is sometimes called, i.e., the study of mental heredity

and development, dovetails with the general biological science of genetics, so that we find biologists gathering data on the heredity of feeble-mindedness or of musical ability, while psychologists discuss the general theory of heredity.

Psychology and physiology. That one of all the sciences that has the closest contacts with psychology is human and animal physiology. Broadly defined, physiology is that part of biology that studies functions or activities; and, so defined, it includes psychology as part of itself. In practice, psychology devotes itself to desire, thought, memory, and such "mental functions", while physiology concentrates its effort upon "bodily functions" like digestion and circulation. But this is only a rough distinction, which breaks down at many points.

Where shall we class sensation? Is it "mental" or "bodily"? Both sciences study it. Physiology is perhaps more apt to go into the detailed study of the action of the sense organs, and psychology to concern itself with the classification of sensations and the use made of them for recognizing objects or for esthetic purposes. But the line between the two sciences is far from sharp at this point.

Speech, also, lies in both provinces. Physiology has studied the action of the vocal organs and the location of the brain centers concerned in speech, while psychology has studied the child's process of learning to speak and the relation of speech to thought, and is more apt to be interested in stuttering, slips of the tongue, and other speech disturbances which are said to be "mental rather than physical".

It would be hard to mention any activity that is mental without being physical at the same time. Even thinking, which seems as purely mental as any, requires brain action; and the brain is just as truly a bodily organ as the heart or stomach. Its activity is bodily activity and lies properly within the field of physiology.

But it would be equally difficult to mention any function that is exclusively bodily, and not mental at the same time, in some degree. Take digestion for example: the pleasant anticipation of food will start the digestive juices flowing, before any food is physically in the stomach; while in anger or fear digestion comes to a sudden halt. Therefore we find physiologists interested in these emotions, and psychologists interested in digestion.

We do not find any clean separation between our science and physiology; but we find, on the whole, that psychology examines what are called "mental" activities, and that it studies them as the performances of the whole individual rather than as executed by the several organs.

THE SCIENCE OF CONSCIOUSNESS

Typically, the activities that psychology studies are conscious performances, while many of those falling to physiology are unconscious. Thus digestion is mostly unconscious, the heart beat is unconscious except when disturbed, the action of the liver is entirely unconscious. Why not say, then, that psychology is the study of conscious activities?

There might be some objection to this definition from the side of physiology, which studies certain conscious activities itself—speech, for example, and especially sensation.

There would be objection also from the side of psychology, which does not wish to limit itself to conscious action. Take the case of any act that can at first be done only with close attention, but that becomes easy and automatic after practice; at first it is conscious, later unconscious, but psychology would certainly need to follow it from the initial to the final stage, in order to make a complete study of the practice effect. And then there is the "unconscious", or the "subconscious mind"—a matter on which psychologists

do not wholly agree among themselves; but all would agree that the problem of the unconscious was appropriate to psychology.

For all the objections, it remains true that the *typical* mental process, the typical matter for psychological study, is conscious. "Unconscious mental processes" are distinguished from the unconscious activity of such organs as the liver by being somehow *like* the conscious mental processes.

It would be correct, then, to limit psychology to the study of conscious activities and of activities akin to these.

THE SCIENCE OF BEHAVIOR

No one has objected so strenuously to defining psychology as the science of consciousness, and limiting it to consciousness, as the group of animal psychologists. By energetic work, they had proved that the animal was a very good subject for psychological study, and had discovered much that was important regarding instinct and learning in animals. But from the nature of the case, they could not observe the consciousness of animals; they could only observe their behavior, that is to say, the motor (and in some cases glandular) activities of the animals under known conditions. When then the animal psychologists were warned by the mighty ones in the science that they must interpret their results in terms of consciousness or not call themselves psychologists any longer, they rebelled; and some of the best fighters among them took the offensive, by insisting that human psychology, no less than animal, was properly a study of behavior, and that it had been a great mistake ever to define it as the science of consciousness.

It is a natural assumption that animals are conscious, but after all you cannot directly observe their consciousness, and you cannot logically confute those philosophers

who have contended that the animal was an unconscious automaton. Still less can you be sure in detail what is the animal's sensation or state of mind at any time; to get at that, you would need a trustworthy report from the animal himself. Each individual must observe his own consciousness; no one can do it from outside. The objection of the behaviorist to "consciousness psychology" arises partly from distrust of this method of inner observation, even on the part of a human observer.

Indeed, we can hardly define psychology without considering its *methods of observation*, since evidently the method of observation limits the facts observed and so determines the character of the science. Psychology has two methods of observation.

When a person performs any act, there are, or may be, two sorts of facts to be observed, the "objective" and the "subjective". The objective facts consist of movements of the person's body or of any part of it, secretions of his glands (as flow of saliva or sweat), and external results produced by these bodily actions—results such as objects moved, path and distance traversed, hits on a target, marks made on paper, columns of figures added, vocal or other sounds produced, etc., etc. Such objective facts can be observed by another person.

The subjective facts can be observed only by the person performing the act. While another person can observe, better indeed than he can himself, the motion of his legs in walking, he alone can observe the sensations in the joints and muscles produced by the leg movement. No one else can observe his pleased or displeased state of mind, nor whether he is thinking of his walking or of something quite different. To be sure, his facial expression, which is an objective fact, may give some clue to his thoughts and feelings, but "there's no art to read the mind's construction

in the face", or at least no sure art. One may feign sleep or absorption while really attending to what is going on around. A child may wear an angelic expression while meditating mischief. To get the subjective facts, we shall have to enlist the person himself as our observer.

INTROSPECTION

This is observation by an individual of his own conscious action. It is also called subjective observation. Notice that it is a form of observation, and not speculation or reasoning from probabilities or from past experience. It is a direct observation of fact.

One very simple instance of introspection is afforded by the study of after-images. Look for an instant at the glowing electric bulb, and then turn your eyes upon a dark background, and observe whether the glowing filament appears there; this would be the "positive after-image". This simple type of introspection is used by physiology in its study of the senses, as well as by psychology; and it gives such precise and regular results that only the most confirmed behaviorists refuse to admit it as a good method of observation.

But psychology would like to make introspective observations on the more complex mental processes as well; and it must be admitted that here introspection becomes difficult. You cannot hope to make minute observations on any process that lasts over a very few seconds, for you must let the process run its natural course unimpeded by your efforts at observing it, and then turn your "mental eye" instantly back to observe it *retrospectively* before it disappears. As a matter of fact, a sensation or feeling or idea hangs on in consciousness for a few seconds, and can be observed in this retrospective way. There is no theoretical objection to this style of introspection, but it is practically difficult and

tricky. Try it on a column of figures: first add the column as usual, then immediately turn back and review exactly what went through your mind in the process of adding—what numbers you spoke internally, etc. Try again by introspecting the process of filling in the blanks in the sentence: "Botany could not make use of introspection because — have probably no — processes." At first, you may find it difficult to observe yourself in this way; for the natural tendency, when you are aiming at a certain result, is to reach the goal and then shift to something else, rather than to turn back and review the steps by which you reached the goal. But with practice, you acquire some skill in introspection.

One difficulty with introspection of the more complex mental processes is that individuals vary more here than in the simpler processes, so that different observers, observing each his own processes, will not report the same facts, and one observer cannot serve as a check upon another so easily as in the simpler introspection of after-images and other sensations, or as in the observations made in other sciences. Even well trained introspectionists are quite at variance when they attempt a minute description of the thought processes, and it is probable that this is asking too much of introspection. We mustn't expect it to give microscopic details. Rough observations, however, it gives with considerable certainty. Who can doubt, for example, that a well-practised act goes on with very little consciousness, or that inner, silent speech often accompanies thinking? And yet we have only introspection to vouch for these facts.

OBJECTIVE OBSERVATION

But to say, as used to be said, that psychology is purely an introspective science, making use of no other sort of observation, is absurd in the face of the facts.

We have animal psychology, where the observation is exclusively objective. In objective observation, the observer watches something else, and not himself. In animal psychology, the psychologist, as observer, watches the animal.

The same is true of child psychology, at least for the first years of childhood. You could not depend on the introspections of a baby, but you can learn much by watching his behavior. Abnormal persons, also, are not often reliable introspectionists, and the study of abnormal psychology is mostly carried on by objective methods.

Now how is it with the normal adult human being, the standard subject for psychology? Does he make all the observations on himself or may he be objectively observed by the psychologist? The latter, certainly. In fact, nearly all tests, such as those used in studying differential psychology, are objective. That is to say that the person tested is given a task to perform, and his performance is observed in one way or another by the examiner. The examiner may observe the *time* occupied by the subject to complete the task, or the *quantity* accomplished in a fixed time; or he may measure the correctness and *excellence* of the work done, or the *difficulty* of the task assigned. One test uses one of these measures, and another uses another; but they are all objective measures, not depending at all on the introspection of the subject.

What is true of tests in differential psychology is true of the majority of experiments in general psychology: the performer is one person, the observer another, and the observation is objective in character. Suppose, for example, you are investigating a memory problem; your method may be to set your subject a lesson to memorize under certain defined conditions, and see how quickly and well he learns it; then you give him another, equally difficult lesson to be learned under altered conditions, and observe whether he

does better or worse than before. Thus you discover which set of conditions is more favorable for memorizing, and thence can infer something of the way in which memorizing is accomplished. In the whole experiment you need not have called on your subject for any introspections; and this is a type of many experiments in which the subject accomplishes a certain task under known conditions, and his success is objectively observed and measured.

There is another type of objective psychological observation, directed not towards the success with which a task is accomplished, but towards the changes in breathing, heart beat, stomach movements, brain circulation, or involuntary movements of the hands, eyes, etc., which occur during the course of various mental processes, as in reading, in emotion, in dreaming or waking from sleep.

Now it is not true as a matter of history that either of these types of objective observation was introduced into psychology by those who call themselves behaviorists. Not at all; experiments of both sorts have been common in psychology since it began to be an experimental science. The first type, the success-measuring experiment, has been much more used than introspection all along. What the behaviorists have accomplished is the definitive overthrow of the doctrine, once strongly insisted on by the "consciousness psychologists", that introspection is the only real method of observation in psychology; and this is no mean achievement. But we should be going too far if we followed the behaviorists to the extent of seeking to exclude introspection altogether, and on principle. There is no sense in such negative principles. Let us accumulate psychological facts by any method that will give the facts.

GENERAL LINES OF PSYCHOLOGICAL INVESTIGATION

Either introspective or objective observation can be employed in the *experimental attack* on a problem, which consists, as just illustrated in the case of memory, in controlling the conditions under which a mental performance occurs, varying the conditions systematically, and noting the resulting change in the subject's mental process or its outcome. Psychologists are inclined to regard this as the best line of attack, whenever the mental activity to be studied can be effectively subjected to control. Unfortunately, emotion and reasoning are not easily brought under control, and for this reason psychology has made slower progress in understanding them than it has made in the fields of sensation and memory, where good experimental procedure has been developed.

Another general line of attack worthy to be mentioned alongside of the experimental is the *comparative method*. You compare the actions of individuals, classes or species, noting likenesses and differences. You see what behavior is typical and what exceptional. You establish norms and averages, and notice how closely people cluster about the norm and how far individuals differ from it. You introduce tests of various sorts, by which to get a more precise measure of the individual's performance. Further, by the use of what may be called double comparison, or "correlation", you work out the relationships of various mental (and physical) traits. For example, when many different species of animals are compared in intelligence and also in brain weight, the two are found to correspond fairly well, the more intelligent species having on the whole the heavier brains: from which we fairly conclude that the size of the brain has something to do with intelligence. But when we correlate brain weight and intelligence in human individuals,

we find so many exceptions to the rule (stupid men with large brains and gifted men with brains of only moderate size) that we are forced to recognize the importance of other factors, such as the perfection of the microscopic structure of the brain.

Tests and correlations have become so prominent in recent psychological investigation that this form of the comparative method ranks on a par with the strict experimental method. A test is an experiment, in a way, and at least is often based upon an experiment; but the difference between the two lines of attack is that an experiment typically takes a few subjects into the laboratory and observes how their mental performances change with planfully changed conditions; whereas a test goes out and examines a large number of persons under one fixed set of conditions. An experiment belongs under what we called "general psychology", and a test under "differential psychology", since the first outcome of a test is to show how the individual differs from others in a certain respect. The results may, however, be utilized in various ways, either for such practical purposes as guiding the individual's choice of an occupation, or for primarily scientific purposes, such as examining whether intelligence goes with brain size, whether twins resemble each other as much mentally as they do physically, whether intellectual ability and moral goodness tend on the whole to go together, or not.

The *genetic method* is another of the general lines of attack on psychological problems. The object here is to trace the mental development of the individual, or of the race. It may be to trace the development either of mentality in general, or of some particular mental performance. It may be to trace the child's progress in learning to speak, or to follow the development of language in the human species, from the most primitive tongues up to those of the great

civilized peoples of to-day. It may be to trace the improvement of a performance with continued practice.

The value of the genetic method is easily seen. Usually the beginnings of a function or performance are comparatively simple and easy to observe and analyze. Also, the process of mental growth is an important matter to study on its own account.

The *pathological method* is akin to the genetic, but traces the decay or demoralization of mental life instead of its growth. It traces the gradual decline of mental power with advancing age, the losses due to brain disease, and the maladaptations that appear in insanity and other disturbances. Here psychology makes close contact with *psychiatry*, which is the branch of medicine concerned with the insane, etc., and which in fact has contributed most of the psychological information derived from the pathological method.

The object of the pathological method is, on the one side, to understand abnormal forms of mental life, with the practical object of preventing or curing them, and on the other side, to understand normal mental life the better. Just as the development of a performance throws light on the perfected act, so the decay or disturbance of a function often reveals its inner workings; for we all know that it is when a machine gets out of order that one begins to see how it ought to work. Failure sheds light on the conditions of success, maladaptation throws into relief the mental work that has to be done by the normal individual in order to secure and maintain his good adaptation. According to the psychiatrists, mental disturbance is primarily an affair of emotion and desire rather than of intellect: and consequently they believe that the pathological method is of special importance in the study of the emotional life.

SUMMARY AND ATTEMPT AT A DEFINITION

Having now made a rapid preliminary survey of the field of psychology, and of the aims and methods of the workers in this field, we ought to be in a position to give some sort of a definition.

We conclude, then: psychology is a part of the scientific study of life, being the science of mental life. Life consisting in process or action, psychology is the scientific study of mental processes or activities. A mental activity is typically, though not universally, conscious; and we can roughly designate as mental those activities of a living creature that are either conscious themselves or closely akin to those that are conscious. Further, any mental activity can also be regarded as a physiological activity, in which case it is analyzed into the action of bodily organs, whereas as "mental" it simply comes from the organism or individual as a whole. Psychology, in a word, is the science of the conscious and near-conscious activities of living individuals.

Psychology is not interested either in dead bodies or in disembodied spirits, but in living and acting individuals.

One word more, on the *psychological point of view*. In everyday life we study our acquaintances and their actions from a personal standpoint. That is, we evaluate their behavior according as it affects ourselves, or, perhaps, according as it squares or not with our standards of right and wrong. We always find something to praise or blame. Now, the psychologist has no concern with praise and blame, but is a seeker after the facts. He would know and understand human actions, rather than pass judgment on them. When, for example, he is introduced into the school or children's court, for the purpose of examining children that are "problems", his attitude differs considerably from that of the

teacher or officer of the law; for while they almost inevitably pass judgment on the child in the way of praise or blame, the psychologist simply tries to understand the child. The young delinquent brought into the laboratory of the court psychologist quickly senses the unwonted atmosphere, where he is neither scolded nor exhorted, but asked to lend his coöperation in an effort to discover the cause why his conduct is as it is. Now, this psychological attitude is not necessarily "better" than the other, but it is distinctly valuable in its place, as seen from the fact that the young delinquent often does coöperate. He feels that if the psychologist can find out what is the trouble with him, this may help. Nothing, indeed, is more probable; it is when we have the facts and trace out cause and effect that we are in a fair way to do good. Nothing is more humane than psychology, in the long run, even though the psychologist may seem unfeeling in the course of his investigation.

To the psychologist, conduct is a matter of cause and effect, of natural law. His business is to know the laws of that part of nature which we call human nature, and to use these laws, as fast as discovered, for solving the problems presented by the human individual or group. For him, even the most capricious conduct has its causes, even the most inexplicable has its explanation—if only the cause can be unearthed, which he does not pretend he can always actually accomplish, since causes in the mental realm are often very complex. No one can be a psychologist all of the time; no one can or should always maintain this matter-of-fact attitude towards self and neighbor. But some experience with the psychological attitude is of practical value to any one, in giving clearer insight, more toleration, better control, and even saner standards of living.

EXERCISES

1. Outline the chapter. A sample outline of the briefer sort is here given:

A. Subject-matter of psychology: mental activities.

- (1) A sub-class under vital activities.
- (2) Activities of individuals, as distinguished from
 - (a) Activities of social groups (sociology).
 - (b) Activities of single organs (physiology).
- (3) Either conscious, or closely related to conscious activities.
- (4) May be activities of human or animal, adult or child, normal or abnormal individuals.

B. Problems of psychology:

- (1) How individuals differ in their mental activities.
- (2) How individuals are alike in their mental activities.
- (3) Practical applications of either (1) or (2).

C. Methods of psychology:

- (1) Methods of observing mental activities.
 - (a) Introspective, the observing by an individual of his own actions.
 - (b) Objective, the observation of the behavior of other individuals.
- (2) General lines of attack upon psychological problems.
 - (a) Experimental: vary the conditions and see how the mental activity changes.
 - (b) Comparative: test different individuals or classes and see how mental activity differs, etc.
 - (c) Genetic: trace mental development.
 - (d) Pathological: examine mental decay or disturbance.

2. Formulate a psychological question regarding each of the following: hours of work, genius, crime, baseball.

3. Distinguish introspection from theorizing.

4. What different sorts of objective fact can be observed in psychology?

5. What is the difference between the physiology of hearing and the psychology of hearing?

6. State two reasons why it would be undesirable to limit psychology to the introspective study of consciousness.

7. What is the difference between an experiment and a test, (a) in purpose, (b) in method?

8. Compare the time it takes you to add twenty one-place numbers, arranged in a vertical column, and arranged in a horizontal line. (a) Is this introspective or objective observation? Why so? (b) Is it a test or an experiment? Why?

9. Write a psychological sketch of some one you know well, taking care to avoid praise and blame, and to stick to the psychological point of view.

REFERENCES

Some of the good books on the different branches of psychology are the following:

On animal psychology:

Margaret F. Washburn, *The Animal Mind*, 2nd edition, 1917.

John B. Watson, *Behavior*, 1914.

On child psychology:

Norsworthy and Whitley, *The Psychology of Childhood*, 1918.

On abnormal psychology:

A. J. Rosanoff, *Manual of Psychiatry*, 5th edition, 1920.

On applied psychology:

Hollingworth and Poffenberger, *Applied Psychology*, 1917.

On individual psychology, parts of:

E. L. Thorndike, *Educational Psychology, Briefer Course*, 1914.

Daniel Starch, *Educational Psychology*, 1919.

CHAPTER II

REACTIONS

REFLEXES AND OTHER ELEMENTARY FORMS OF REACTION, AND HOW THE NERVES OPERATE IN CARRYING THEM OUT

Having the field of psychology open before us, the next question is, where to commence operations. Shall we begin with memory, imagination and reasoning, or with will, character and personality, or with motor activity and skill, or with feelings and emotions, or with sensation and perceptions? Probably the higher forms of mental activity seem most attractive, but we may best leave complicated matters till later, and agree to start with the simplest sorts of mental performance. Thus we may hope to learn at the outset certain elementary facts which will later prove of much assistance in unraveling the more complex processes.

Among the simplest processes are sensations and reflexes, and we might begin with either. The introspective psychologists usually start with sensations, because their great object is to describe consciousness, and they think of sensations as the chief elements of which consciousness is composed. The behaviorists would prefer to start with reflexes, because they conceive of behavior as composed of these simple motor reactions.

Without caring to attach ourselves exclusively to either introspectionism or behaviorism, we may take our cue just here from the behaviorists, because we shall find the facts of motor reaction more widely useful in our further studies than the facts of sensation, and because the facts of sensa-

tion fit better into the general scheme of reactions than the facts of reaction fit into any general scheme based on sensation.

A reaction is a *response* to a *stimulus*. The response, in the simplest cases, is a muscular movement, and is called a "motor response". The stimulus is any force or agent that, acting upon the individual, arouses a response.

If I start at a sudden noise, the noise is the stimulus, and the forcible contraction of my muscles is the response. If my old friend's picture brings tears to my eyes, the picture (or the light reflected from it) is the stimulus, and the flow of tears is the response, here a "glandular" instead of a motor response.

THE REACTION TIME EXPERIMENT

One of the earliest experiments to be introduced into psychology was that on reaction time, conducted as follows: The experimenter tells his "subject" (the person whose reaction is to be observed) to be ready to make a certain movement as promptly as possible on receiving a certain stimulus. The response prescribed is usually a slight movement of the forefinger, and the stimulus may be a sound, a flash of light, a touch on the skin, etc. The subject knows in advance exactly what stimulus is to be given and what response he has to make, and is given a "Ready!" signal a few seconds before the stimulus. With so simple a performance, the reaction time is very short, and delicate apparatus must be employed to measure it. The "chronoscope" or clock used to measure the reaction time reads to the hundredth or thousandth of a second, and the time is found to be about .15 sec. in responding to sound or touch, about .18 sec. in responding to light.

Even the simple reaction time varies, however, from one

individual to another, and from one trial to another. Some persons can never bring their record much below the figures stated, while a few can get the time down to .10 sec., which is about the limit of human ability. Every one is bound to vary from trial to trial, at first widely, after practice between narrow limits, but always by a few hundredths of a second at the least. It is curious to find the elementary fact of variability of reaction present in such a simple performance.

What we have been describing is known as the "simple reaction", in distinction from other experiments that demand more of the subject. In the "choice reaction", there are two stimuli and the subject may be required to react to the one with the right hand and to the other with the left; for example, if a red light appears he must respond with the right hand, but if a green light appears, with the left. Here he cannot allow himself to become keyed up to as high a pitch as in the simple reaction, for if he does he will make many false reactions. Therefore, the choice reaction time is longer than the simple reaction time—about a tenth of a second longer.

The "associative reaction" time is longer still. Here the subject must name any color that is shown, or read any letter that is shown, or respond to the sight of any number by calling out the next larger number, or respond to any suitable word by naming its opposite. He cannot be so well prepared as for the simple or choice reaction, since he doesn't know exactly what the stimulus is going to be; also, the brain process is more complex here; so that the reaction time is longer, about a tenth of a second longer, at the best, than the choice reaction. It may run up to two or three seconds, even in fairly simple cases, while if any serious thinking or choosing has to be done, it runs into many seconds and even into minutes. Here the brain process is very

complex and involves a series of steps before the required motor response can be made.

These laboratory experiments can be paralleled by many everyday performances. The runner starting at the pistol shot, after the preparatory "Ready! Set!", and the motor-man applying the brakes at the expected sound of the bell, are making "simple" reactions. The boxer, dodging to the right or the left according to the blow aimed at him by his adversary, is making choice reactions, and this type is very common in all kinds of steering, handling tools and managing machinery. Reading words, adding numbers, and a large share of simple mental performances, are essentially associative reactions. In most cases from ordinary life, the *preparation* is less complete than in the laboratory experiments, and the reaction time is accordingly longer.

REFLEX ACTION

The simple reaction has some points of resemblance with the "reflex", which, also, is a prompt motor response to a sensory stimulus. A familiar example is the reflex wink of the eyes in response to anything touching the eyeball, or in response to an object suddenly approaching the eye. This "lid reflex" is quicker than the quickest simple reaction, taking about .05 second. The knee jerk or "patellar reflex", aroused by a blow on the patellar tendon just below the knee when the knee is bent and the lower leg hanging freely, is quicker still, taking about .03 second. The reason for this extreme quickness of the reflex will appear as we proceed. However, not every reflex is as quick as those mentioned, and some are slower than the quickest of the simple reactions.

A few other examples of reflexes may be given. The "pupillary reflex" is the narrowing of the pupil of the eye

in response to a bright light suddenly shining into the eye. The "flexion reflex" is the pulling up of the leg in response to a pinch, prick or burn on the foot. Coughing and sneezing are like this in being protective reflexes, and the scratching of the dog belongs here also.

There are many internal reflexes: movements of the stomach and intestines, swallowing and hiccoughing, widening and narrowing of the arteries resulting in flushing and paling of the skin. These are muscular responses; and there are also glandular reflexes, such as the discharge of saliva from the salivary glands into the mouth, in response to a tasting substance, the flow of the gastric juice when food reaches the stomach, the flow of tears when a cinder gets into the eye. There are also inhibitory reflexes, such as the momentary stoppage of breathing in response to a dash of cold water. All in all, a large number of reflexes are to be found.

Most reflexes can be seen to be *useful* to the organism. A large proportion of them are protective in one way or another, while others might be called regulative, in that they adjust the organism to the conditions affecting it.

Now comparing the reflex with the simple reaction, we see first that the reflex is more deep-seated in the organism, and more essential to its welfare. The reflex is typically quicker than the simple reaction. The reflex machinery does not need a "Ready" signal, nor any preparation, but is always ready for business. (The subject in a simple reaction experiment would not make the particular finger movement that he makes unless he had made ready for that movement.) The attachment of a certain response to a certain stimulus, rather arbitrary and temporary in the simple reaction, is inherent and permanent in the reflex. Reflex action is involuntary and often entirely unconscious.

Reflexes, we said, are permanent. That is because they

are native or inherent in the organism. You can observe them in the new-born child. The reflex connection between stimulus and response is something the child brings with him into the world, as distinguished from what he has to acquire through training and experience. He does acquire, as he grows up, a tremendous number of habitual responses that become automatic and almost unconscious, and these "secondary automatic" reactions resemble reflexes pretty closely. Grasping for your hat when you feel the wind taking it from your head is an example. These acquired reactions never reach the extreme speed of the quickest reflexes, but at best may have about the speed of the simple reaction. Though often useful enough, they are not so fundamentally necessary as the reflexes. The reflex connection of stimulus and response is something essential, native, closely knit, and always ready for action.

THE NERVES IN REFLEX ACTION

Seeing that the response, in reflex action, is usually made by a muscle or gland lying at some distance from the sense organ that receives the stimulus—as, in the case of the flexion reflex, the stimulus is applied to the skin of the hand (or foot), while the response is made by muscles of the limb generally—we have to ask what sort of connection exists between the stimulated organ and the responding organ, and we turn to physiology and anatomy for our answer. The answer is that the *nerves* provide the connection. Strands of nerve extend from the sense organ to the muscle.

But the surprising fact is that the nerves do not run directly from the one to the other. There is no instance in the human body of a direct connection between any sense organ and any muscle or gland. The nerve path from sense organ to muscle always leads through a *nerve center*. One

nerve, called the sensory nerve, runs from the sense organ to the nerve center, and another, the motor nerve, runs from the center to the muscle; and the only connection between

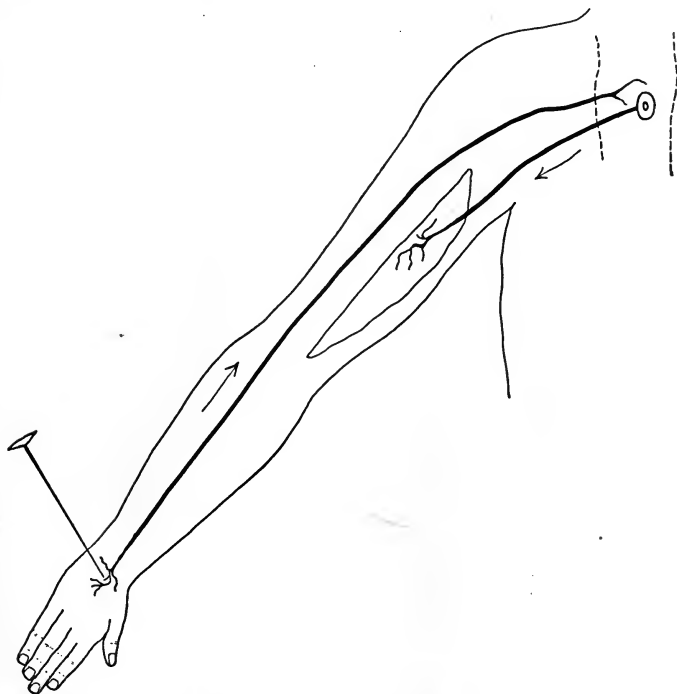

FIG. 1.—The connection from the back of the hand, which is receiving a stimulus, and the arm muscle which makes the response. The nerve center is indicated by the dotted lines.

the sense organ and the muscle is this roundabout path through the nerve center. The path consists of three parts, sensory nerve, center, and motor nerve, but, taken as a whole, it is called the *reflex arc*, both the words, “reflex” and “arc”, being suggested by the indirectness of the connection.

The *nervous system* resembles a city telephone system. What passes along the nerve is akin to the electricity that

passes along the telephone wire; it is called the "nerve current", and is electrical and chemical in nature. All nerve

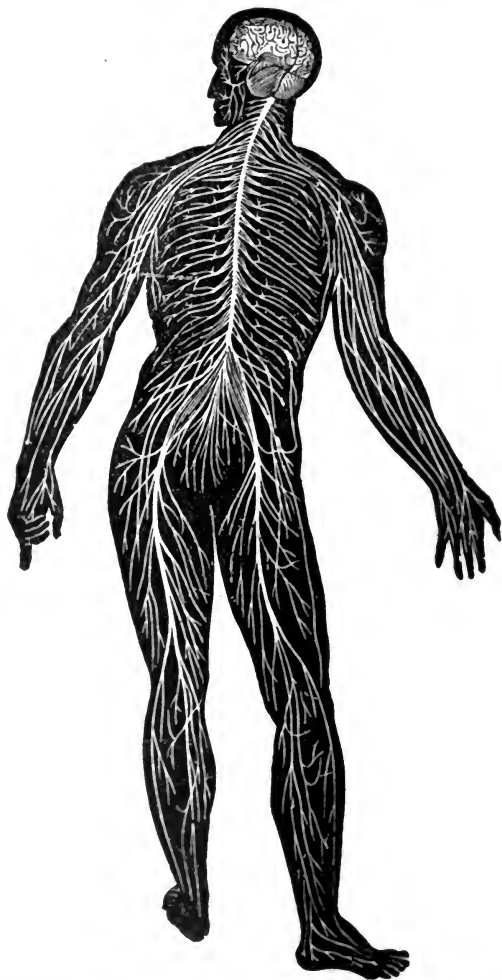

FIG. 2.—(From Martin's "Human Body.") General view of the nervous system, showing brain, cord, and nerves.

connections, like the great majority of telephone connections, are effected through the centers, called "centrals" in

the case of the telephone. Telephone A is connected directly with the central, telephone B likewise, and A and B are indirectly connected, through the central switchboard. That is the way it is in the nervous system, with "nerve center"

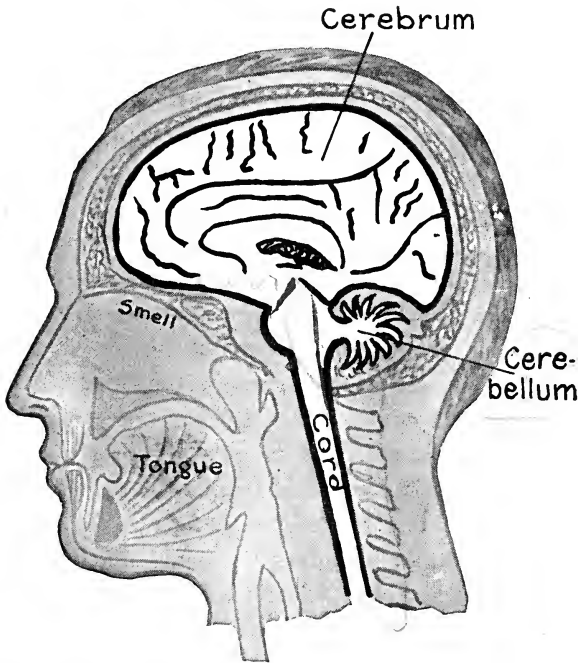

FIG. 3.—Location of the cord, cerebrum and cerebellum. The brain stem continues the cord upward into the skull cavity.

substituted for "central", and "sense organ" and "muscle or gland" for "telephones A and B."

The advantage of the centralized system is that it is a *system*, affording connections between any part and any other, and unifying the whole complex organism.

The *nerve centers* are located in the brain and spinal cord. The brain lies in the skull and the cord extends from the brain down through a tube in the middle of the back-

bone. Of the brain many parts can be named, but for the present it is enough to divide it into the "brain stem", a continuation of the spinal cord up along the base of the skull cavity, and the two great outgrowths of the brain stem, called "cerebrum" and "cerebellum". The spinal cord and brain stem contain the lower or reflex centers, while the cerebellum, and especially the cerebrum, contain the "higher centers". The lower centers are directly connected by nerves with the sense organs, glands and muscles, while the higher centers have direct connections with the lower and only through them with the sense organs, glands and muscles. In other words, the sensory nerves run into the cord or brain stem, and the motor nerves run out of these same, while interconnecting nerve strands extend between the lower centers in the cord and brain stem and the higher centers in the cerebrum and cerebellum.

The spinal cord contains the reflex centers for the limbs and part of the trunk, and is connected by sensory and motor nerves with the limbs and trunk. The brain stem contains the reflex centers for the head and also for part of the interior of the trunk, including the heart and lungs, and is connected with them by sensory and motor nerves. The nerve center that takes part in the flexion reflex of the foot is situated in the lower part of the cord, that for the similar reflex of the hand lies in the upper part of the cord, that for breathing lies in the lower or rear part of the brain stem, and that for winking lies further forward in the brain stem.

Big movements, such as the combined action of all four legs of an animal in walking, require cord and brain stem to work together, and throw into relief what is really true even of simpler reflexes, namely that a reflex is a *co-ordinated* movement, in the sense that different muscles cooperate in its execution.

INTERNAL CONSTRUCTION OF THE NERVES AND NERVE CENTERS

We shall understand nerve action better if we know something of the way in which the nervous system is built. A nerve is not to be thought of as a unit, nor are the brain

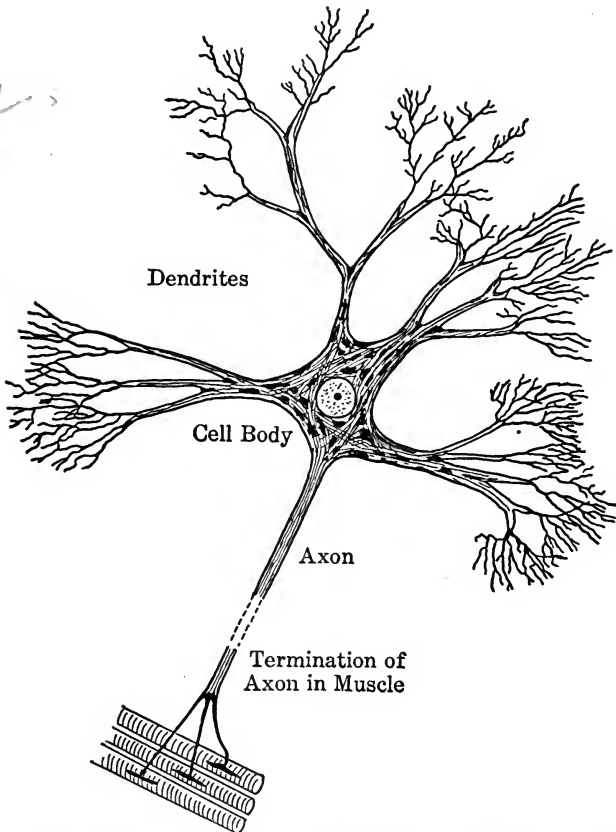

FIG. 4.—A motor nerve cell from the spinal cord, highly magnified.

and cord to be thought of as mere masses of some peculiar substance. A nerve is a bundle of many slender insulated threads, just as a telephone cable, running along the street,

is a bundle of many separate wires which are the real units of telephonic communication. A nerve center, like the switchboard in a telephone central, consists of many parts and connections.

The whole nervous system is essentially composed of *neurones*. A neurone is a nerve cell with its branches. Most nerve cells have two kinds of branches, called the *axon* and the *dendrites*.

The nerve cell is a microscopic speck of living matter. Its dendrites are short tree-like branches, while its axon is often several inches or even feet in length. The axon is the "slender thread", just spoken of as analogous to the single telephone wire. A nerve is composed of axons.¹ The "white matter" of the brain and cord is composed of axons. Axons afford the means of communication between the nerve centers and the muscles and sense organs, and between one nerve center and another.

The axons which make up the motor nerves are branches of nerve cells situated in the cord and brain stem; they extend from the reflex center for any muscle out to and into that muscle and make very close connection with the muscle substance. A nerve current, starting from the nerve cells in the reflex center, runs rapidly along the axons to the muscle and arouses it to activity.

The axons which make up the optic nerve, or nerve of sight, are branches of nerve cells in the eye, and extend into the brain stem. Light striking the eye starts nerve currents, which run along these axons into the brain stem. Similarly, the axons of the nerve of smell are branches of cells in the nose.

The remainder of the sensory axons are branches of nerve cells that lie in little bunches close alongside the cord or

¹ The axon is always protected or insulated by a sheath, and axon and sheath, taken together, are often called a "nerve fiber".

brain stem. These cells have no dendrites, but their axon, dividing, reaches in one direction out to a sense organ and in the other direction into the cord or brain stem, and thus connects the sense organ with its "lower center".

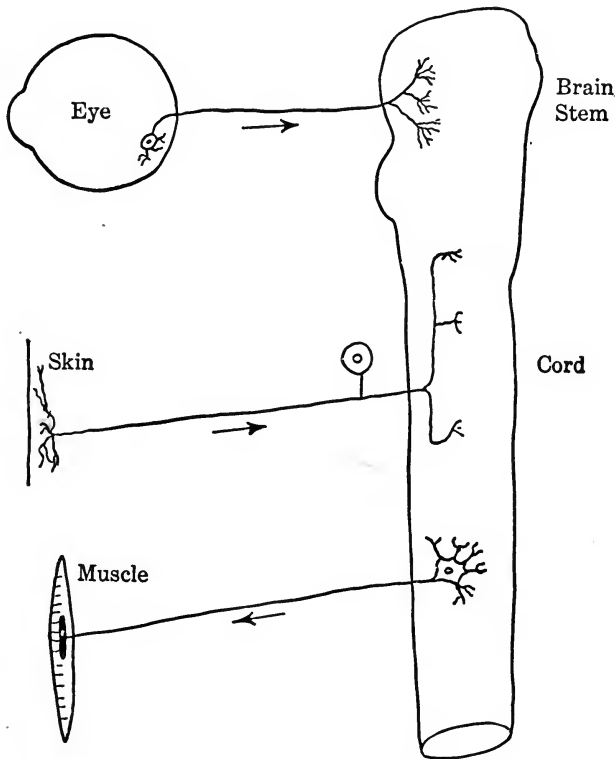

FIG. 5.—Sensory and motor axons, and their nerve cells. The arrows indicate the direction of conduction.

Where an axon terminates, it broadens out into a thin plate, or breaks up into a tuft of very fine branches (the "end-brush"), and by this means makes close contact with the muscle, the sense organ, or the neurone with which it connects.

THE SYNAPSE

Now let us consider the mode of connection between one neurone and another in a nerve center. The axon of one neurone, through its end-brush, is in close contact with the dendrites of another neurone. There is contact, but no actual growing-together; the two neurones remain distinct, and this contact or junction of two neurones is called a "synapse". The synapse, then, is not a thing, but simply a junction between two neurones.

The junction is good enough so that one of the two neurones, if itself active, can arouse the other to activity. The

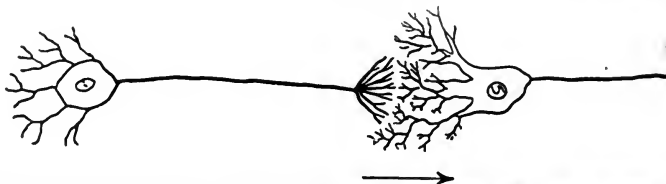

FIG. 6.—The synapse between the two neurones lies just above the arrow.

end-brush, when a nerve current reaches it from its own nerve cell, arouses the dendrites of the other neurone, and thus starts a nerve current running along those dendrites to their nerve cell and thence out along its axon.

Now here is a curious and significant fact: the dendrites are receiving organs, not transmitting; they pick up messages from the end-brushes across the synapse, but send out no messages to those end-brushes. Communication across a synapse is always in one direction, from end-brush to dendrites.

This, then, is the way in which a reflex is carried out, the pupillary reflex, for example. Light entering the eye starts a nerve current in the axons of the optic nerve; these axons terminate in the brain stem, where their end-brushes arouse the dendrites of motor nerve cells, and the axons of these

cells, extending out to the muscle of the pupil, cause it to contract, and narrow the pupil.

Or again, this is the way in which one nerve center arouses another to activity. The axons of the cells in the first center (or some of them) extend out of this center and through the white matter to the second center, where they

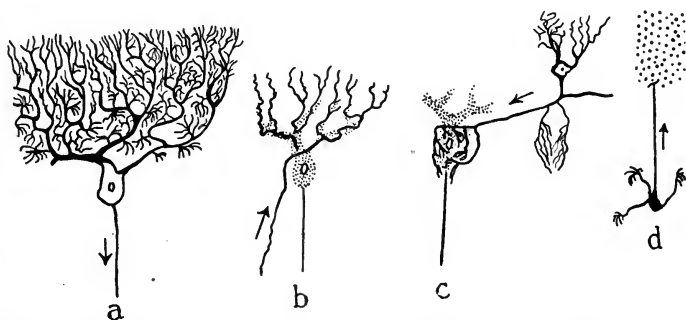

FIG. 7.—Different forms of synapse found in the cerebellum. "a" is one of the large motor cells of the cerebellum (a "Purkinje cell"), with its dendrites above and its axon below; and "b," "c" and "d" show three forms of synapse made by other neurones with this Purkinje cell. In "b," the arrow indicates a "climbing axon," winding about the main limbs of the Purkinje cell. In "c," the arrow points to a "basket"—an end-brush enveloping the cell body; while "d" shows what might be called a "telegraph-wire synapse." Imagine "d" superimposed upon "a": the axon of "d" rises among the fine dendrites of "a," and then runs horizontally through them; and there are many, many such axons strung among the dendrites. Thus the Purkinje cell is stimulated at three points: cell body, trunks of the dendrites, and twigs of the dendrites.

terminate, their end-brushes forming synapses with the cells of the second center. Let the first center be thrown into activity, and immediately, through this connection, it arouses the second.

The "gray matter" comprises the nerve centers, lower and higher. It is made up of nerve cells and their dendrites, of the beginnings of axons issuing from these cells and of the terminations of incoming axons. The white matter, as was said before, consists of axons. An axon issues from the

gray matter at one point, traverses the white matter for a longer or shorter distance, and finally turns into the gray matter at another point, and thus nerve connection is maintained between these two points.

There are lots of nerve cells, billions of them. That ought to be plenty, and yet—well, perhaps sometimes they are

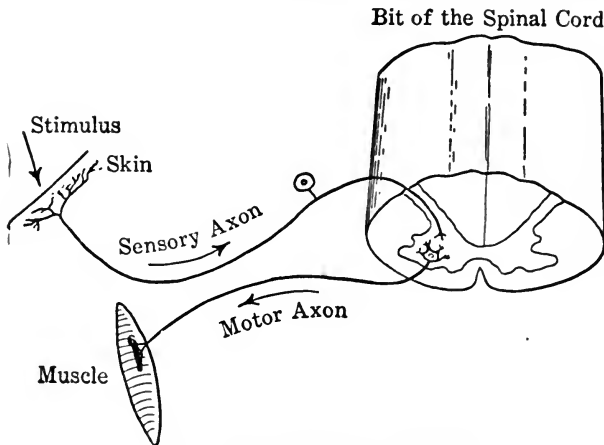

FIG. 8.—A two-neurone reflex arc.

not well developed, or their synapses are not close enough to make good connections.

Examined under the microscope, the nerve cell is seen to contain, besides the "nucleus" which is present in every living cell and is essential for maintaining its vitality and special characteristics, certain peculiar granules which appear to be stores of fuel to be consumed in the activity of the cell, and numerous very fine fibrils coursing through the cell and out into the axon and dendrites.

The *reflex arc can now be described* more precisely than before. Beginning in a sense organ, it extends along a sensory axon (really along a team of axons acting side by side) to its end-brush in a lower center, where it crosses a synapse and enters the dendrites of a motor neurone and so

reaches the cell body and axon of this neurone, which last extends out to the muscle (or gland). The simplest reflex arc consists then of a sensory neurone and a motor neurone, meeting at a synapse in a lower or reflex center. This would be a two-neurone arc. Very often, and possibly always, the

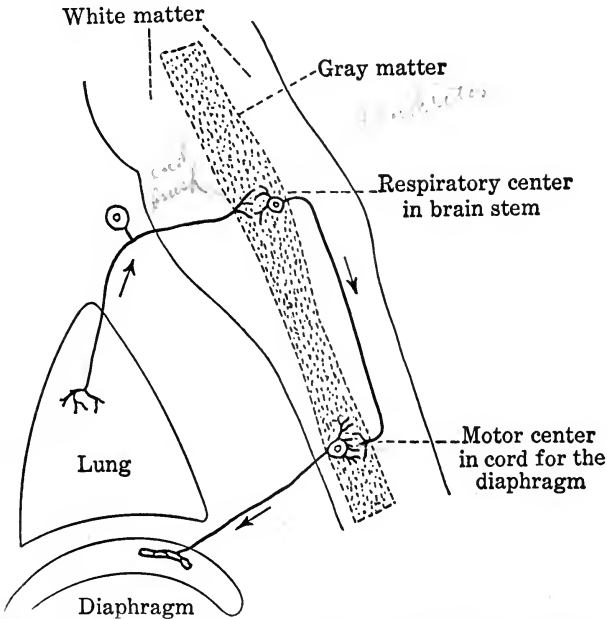

FIG. 9.—A three-neurone arc, concerned in respiration. This also illustrates how one nerve center influences another.

reflex arc really consists of three neurones, a "central" neurone intervening between the sensory and motor neurones and being connected through synapses with each. The central neurone plays an important rôle in coördination.

COÖRDINATION

The internal structure of nerve centers helps us see how coördinated movement is produced. The question is, how

several muscles are made to work together harmoniously, and also how it is possible that a pin prick, directly affecting just a few sensory axons, causes a big movement of many muscles. Well, we find the sensory axon, as it enters the cord, sending off a number of side branches, each of which terminates in an end-brush in synaptic connection with the

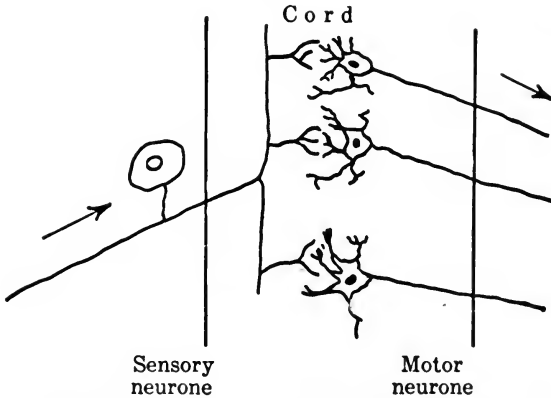

FIG. 10.—Coördination brought about by the branching of a sensory axon.

dendrites of a motor nerve cell. Thus the nerve current from a single sensory neurone is distributed to quite a number of motor neurones. Where there are central neurones in the arc, their branching axons aid in distributing the excitation; and so we get a big movement in response to a minute, though intense stimulus.

But the response is not simply big; it is definite, co-ordinated, representing team work on the part of the muscles as distinguished from indiscriminate mass action. That means selective distribution of the nerve current. The axons of the sensory and central neurones do not connect with any and every motor neurone indiscriminately, but link up with selected groups of motor neurones, and thus harness together teams that will work in definite ways, producing

flexion of a limb in the case of one such team, and extension in the case of another. Every reflex has its own team of motor neurones, harnessed together by its outfit of sensory and central neurones. The same motor neurone may however be harnessed into two or more such teams, as is seen from the fact that the same muscle may participate in different reflex movements; and for a similar reason we believe that the same sensory neurone may be utilized in more than

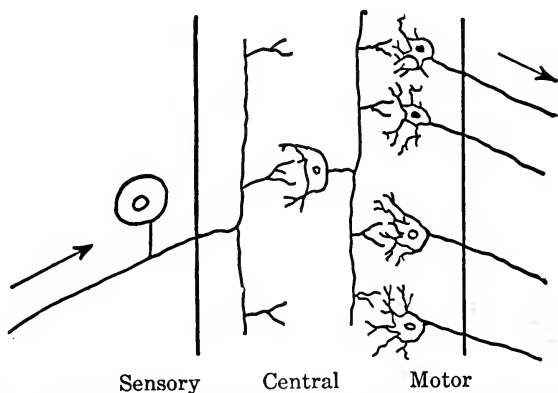

FIG. 11.—Coördination brought about by the branching of the axon of a central neurone.

one reflex arc. The most distinctive part of any reflex arc is likely to be its central neurones, which are believed to play the chief part in coördination, and in determining the peculiarities of any given reflex, such as its speed and rhythm of action.

REACTIONS IN GENERAL

Though the reflex is simple by comparison with voluntary movements, it is not the simplest animal reaction, for it is coördinated and depends on the nervous system, while the simplest animals, one-celled animals, have no nervous system, any more than they have muscles or organs of any

kind. Without possessing separate organs for the different vital functions, these little creatures do nevertheless take in and digest food, reproduce their kind, and move. Every animal shows at least two different motor reactions, a positive or approaching reaction, and a negative or avoiding reaction.

The general notion of a reaction is that of a *response* to a *stimulus*. The stimulus acts on the organism and the organism acts back. If I am struck by a wave and rolled over on the beach, that is passive motion and not my reaction; but if the wave stimulates me to maintain my footing, then I am active, I respond or react.

Now there is no such thing as wholly passive motion. Did not Newton teach that "action and reaction are equal"?—and he was thinking of stones and other inanimate objects. The motion of a stone or ball depends on its own weight and shape and elasticity as much as on the blow it receives. Even the stone counts for something in determining its own behavior.

A loaded gun counts for more than a stone, because of the stored energy of the powder that is set free by the blow of the hammer. The "reaction" of the gun is greater than the force acting on it, because of this stored energy that is discharged.

An animal reaction resembles the discharge of the gun, since there is stored energy in the animal, consisting in the chemical attraction between food absorbed and oxygen inspired, and some of this energy is utilized and converted into motion when the animal reacts. The stimulus, like the trigger of the gun, simply releases this stored energy.

The organism, animal or human, fully obeys the law of conservation of energy, all the energy it puts out being accounted for by stored energy it has taken in in food and oxygen. But at any one time, when the organism receives

a stimulus, the energy that it puts forth in reaction comes from inside itself.

There is another way in which the organism counts in determining its reaction. Not only does it supply the energy of the response, but its own internal arrangements determine *how* that energy shall be directed. That is to say, the organism does not blow up indiscriminately, like a charge of dynamite, but makes some definite movement. This is true even of the simplest animals, and the more elaborate the internal mechanism of the animal, the more the animal itself has to do with the kind of response it shall make to a stimulus. The nervous system of the higher animals, by the connections it provides between the stimulus and the stores of energy in the muscles, is of especial importance in determining the nature of the response.

Stimuli are necessary to arouse the activity of the organism. Without any stimulus whatever, it seems likely that the animal would relapse into total inactivity. It should be said, however, that stimuli, such as that of hunger, may arise within the organism itself. The stimulus may be external or internal, but some stimulus is necessary in order to release the stored energy.

In general, then, a reaction consists in the release by a stimulus of some of the stored energy of an animal, and the direction of that energy by the animal's own internal mechanism of nerves and muscles (and, we may add, bones and sinews) into the form of some definite response.

EXERCISES

1. Outline of the chapter, being at the same time a "completion test". Complete the following outline by filling in the blank spaces (usually a single word will fill the blank, but sometimes two words will be better):

- A. Definition: A reaction is a response to a _____. The stimulus _____ energy stored in the organism, and the _____ has a definite form determined by the organism's own machinery of _____ and _____.
- B. Among very prompt reactions are the reflex and the "simple reaction". The reflex differs from the "simple reaction" in that:
- (1) It usually takes less _____.
 - (2) It requires no _____.
 - (3) The machinery for it is _____ in the organism.
- C. The machinery for a reflex consists of:
- (1) a _____ organ.
 - (2) a _____ nerve.
 - (3) a nerve _____.
 - (4) a _____ nerve.
 - (5) a muscle or _____.
- D. The sensory and motor nerves consist of _____, which are branches of _____. The cells for the motor nerves lie in the _____, and those for the sensory nerves lie in two cases in the _____, and in all other cases in bunches located close beside the _____ or _____.
- E. The neurone is the _____ of which the nervous _____ is composed. It consists of a _____, and of two sorts of branches, the _____ and the _____. Internally, the neurone shows a peculiar structure of _____ and _____.
- F. Communication from one neurone to another occurs across a _____ called the synapse. The _____ of an axon here comes into close contact with the _____ or with the _____ of another neurone. The communication takes place from the _____ of the first neurone to the _____ of the second.
- G. The "nerve current" in a reflex therefore runs the following course: from the sense organ into a _____ axon, along this to its _____ in a nerve _____, and across a _____ there into the _____ of a _____ neurone, and thence

out along the ——— of this neurone to the ——— or ——— that executes the reflex. This is a two-neurone ———, but often there is a third, ——— neurone between the ——— and the ———.

H. Coördination is effected by the ——— of the axons of the sensory and ——— neurones, by which means the nerve current is ——— to a team of ———, and so to a team of ———.

2. Is the reaction time experiment, as described in the text, an introspective or an objective experiment?

3. Mention two cases from common life that belong under the "simple reaction", two that belong under "choice reaction", and two that belong under the "associative reaction".

4. Arrange the reflexes mentioned in the text under the two heads of "protective" and "regulative".

5. Draw diagrams of (a) the neurone, (b) a synapse, (c) a reflex arc, and (d) a coördinated movement. Reduce each drawing to the simplest possible form, and still retain everything that is essential.

6. What part of the nervous system lies (a) in the forehead and top of the head, (b) in the very back of the head, (c) along the base of the skull, (d) within the backbone, (e) in the arm?

7. Using a watch to take the time, see how long it takes you to name the letters in a line of print, reading them in reverse order from the end of the line to the beginning. Compare with this time the time required to respond to each letter by the letter following it in the alphabet (saying "n" when you see m, and "t" when you see s, etc.). Which of these two "stunts" is more like reflex action, and how, nevertheless, does it differ from true reflex action?

8. The pupillary reflex. Describe the reaction of the pupil of the eye to light suddenly shining into the eye. This response can best be observed in another person, but you can observe it in yourself by aid of a hand mirror. On another person you can also observe the "crossed" pupillary reflex, by throwing the light into one eye only while you watch the other eye. What sort of connection do you suppose to exist between the two eyes, making this crossed reflex possible?

9. The lid reflex, or wink reflex. (a) Bring your hand suddenly close to another person's eye, and notice the response of the eyelid. (b) See whether you can get a crossed reflex here. (c) See whether your subject can voluntarily prevent (inhibit) the lid reflex. (d) See whether the reflex occurs when he gives the stimulus himself, by moving his own hand suddenly up to his eye. (e) What other stimulus, besides the visual one that you have been using, will arouse the same response?

REFERENCES

C. Judson Herrick, in his *Introduction to Neurology*, 2nd edition, 1918, gives a fuller and yet not too detailed account of the neurone in Chapter III, and of reflex action in Chapter IV.

Percy G. Stiles, in his *Nervous System and Its Conservation*, 1915, discusses these matters in Chapters II, III and IV.

Ladd and Woodworth's *Elements of Physiological Psychology*, 1911, has chapters on these topics.

CHAPTER III

REACTIONS OF DIFFERENT LEVELS

HOW SENSATIONS, PERCEPTIONS AND THOUGHTS MAY
BE CONSIDERED AS FORMS OF INNER RESPONSE, AND
HOW THESE HIGHER REACTIONS ARE RELATED IN
THE NERVOUS SYSTEM TO THE SIMPLER RESPONSES
OF THE REFLEX LEVEL.

Having defined a reaction as an act of the individual aroused by a stimulus, there is no reason why we should not include a great variety of mental processes under the general head of reactions. Any mental process is an activity of the organism, and it is aroused by some stimulus, external or internal; therefore, it is a reaction.

I hear a noise—now, while the noise, as a physical stimulus, comes to me, my hearing it is my own act, my sensory reaction to the stimulus. I recognize the noise as the whistle of a steamboat—this recognition is clearly my own doing, dependent on my own past experience, and may be called a perception or perceptive response. The boat's whistle reminds me of a vacation spent on an island—clearly a memory response. The memory arouses an agreeable feeling—an affective response, this may be called. In its turn, this may lead me to imagine how pleasant it would be to spend another vacation on that island, and to cast about for ways and means to accomplish this result—here we have imagination and reasoning, aroused by what preceded just as the sensation was aroused by the physical stimulus.

In speaking of any mental process as an act of the individual, we do not mean to imply that he is always *conscious*

of his activity. Sometimes he feels active, sometimes passive. He feels active in hard muscular work or hard thinking, while he feels passive in reflex action, in sensation, and in simply "being reminded" of anything without any effort on his own part. But he is active in everything he does, and he does everything that depends on his being alive. Life is activity, and every manifestation of life, such as reflex action or sensation, is a form of vital activity. The only way to be inactive is to be dead.

But vital activity is not "self-activity" in any absolute sense, for it is *aroused* by some stimulus. It does not issue from the individual as an isolated unit, but is his *response* to a stimulus. That is the sense of calling any mental process a reaction; it is something the individual does in response to a stimulus.

To call a sensation a form of reaction means, then, that the sensation is not something done to the person, nor passively received by him from outside, but something that he himself does when aroused to this particular form of activity. What comes from outside and is received by the individual is the stimulus, and the sensation is what he does in response to the stimulus. It represents the discharge of internal stored energy in a direction determined by his own inner mechanism. The sensation depends on his own make-up as well as on the nature of the stimulus, as is especially obvious when the sensation is abnormal or peculiar. Take the case of color blindness. The same stimulus that arouses in most people the sensation of red arouses in the color-blind individual the sensation of brown. Now what the color-blind individual *receives*, the light stimulus, is the same as what others receive, but he responds differently, *i.e.*, with a different sensation, because his own sensory apparatus is peculiar.

The main point of this discussion is that all mental phe-

nomena, whether movements, sensations, emotions, impulses or thoughts, are a person's acts, but that every act is a response to some present stimulus. This rather obvious truth has not always seemed obvious. Some theorists, in emphasizing the spontaneity and "self-activity" of the individual, have pushed the stimulus away into the background; while others, fixing their attention on the stimulus, have treated the individual as the passive recipient of sensation and "experience" generally. Experience, however, is not received; it is lived, and that means done; only, it is done in response to stimuli. The concept of reaction covers the ground.

While speaking of sensations and thoughts as belonging under the general head of reactions, it is well, however, to bear in mind that all mental action tends to arouse and terminate in muscular and glandular activity. A thought or a feeling tends to "express itself" in words or (other) deeds. The motor response may be delayed, or inhibited altogether, but the tendency is always in that direction.

DIFFERENT SORTS OF STIMULI

To call all mental processes reactions means that it is always in order to ask for the stimulus. Typically, the stimulus is an external force or motion, such as light or sound, striking on a sense organ. There are also the internal stimuli, consisting of changes occurring within the body and acting on the sensory nerves that are distributed to the muscles, bones, lungs, stomach and most of the organs. The sensations of muscular strain and fatigue, and of hunger and thirst, are aroused by internal stimuli, and many reflexes are aroused in the same way.

Such internal stimuli as these are like the better known external stimuli in that they act upon sense organs; but it

seems necessary to recognize another sort of stimuli which act directly on the nerve centers in the brain. These may be called "central stimuli" and so contrasted with the "peripheral stimuli" that act on any sense organ, external or internal. To do this is to take considerable liberty with the plain meaning of "stimulus", and calls for justification. What is the excuse for thus expanding the notion of a stimulus?

The excuse is found in the frequent occurrence of mental processes that are not directly aroused by any peripheral stimulus, though they are plainly aroused by something else. Anything that arouses a thought or feeling can properly be called its stimulus. Now it often happens that a thought is aroused by another, just preceding thought; and it seems quite in order to call the first thought the stimulus and the second the response. A thought may arouse an emotion, as when the thought of my enemy, suddenly occurring to mind, makes me angry; the thought is then the stimulus arousing this emotional response.

If hearing you speak of Calcutta makes me think of India, your words are the stimulus and my thought the response. Well, then, if I *think* of Calcutta in the course of a train of thought, and next think of India, what else can we say than that the thought of Calcutta acts as a stimulus to arouse the thought of India as the response? In a long train of thought, where A reminds you of B and B of C and C of D, each of these items is, first, a response to the preceding, and, second, a stimulus to the one following.

There is no special difficulty with the notion of "central stimuli" from the physiological side. We have simply to think of one nerve center arousing another by means of the tract of axons connecting the two. Say the auditory center is aroused by hearing some one mention your friend's name,

and this promptly calls up a mental picture of your friend; here the auditory center has aroused the visual. What happens in a train of thought is that first one group of neurones is aroused to activity, and then this activity, spreading along the axons that extend from this group of neurones to another, arouses the second group to activity; and so on. The brain process may often be exceedingly complex, but this simple scheme gives the gist of it.

The way nerve currents must go shooting around the brain from one center or group of neurones to another, keeping it up for a long time without requiring any fresh peripheral stimulus, is remarkable. We have evidence of this sort of thing in a dream or fit of abstraction. Likely enough, the series of brain responses would peter out after awhile, in the absence of any fresh peripheral stimulus, and total inactivity ensue. But response of one brain center to nerve currents coming from another brain center, and not directly from any sense organ, must be the rule rather than the exception, since most of the brain neurones are not directly connected with any sense organ, but only with other parts of the brain itself. All the evidence we have would indicate that the brain is not "self-active", but only responsive; but, once thrown into activity at one point, it may successively become active at many other points, so that a long series of mental operations may follow upon a single sensory stimulus.

THE MOTOR CENTERS, LOWER AND HIGHER

A "center" is a collection of nerve cells, located somewhere in the brain or cord, which gives off axons running to some other center or out to muscles or glands, while it also receives axons coming from other centers, or from sense organs. These incoming axons terminate in end-brushes and so form synapses with the dendrites of the local

nerve cells. The axons entering any center and terminating there arouse that center to activity, and this activity, when aroused, is transmitted out along the axons issuing from that center, and produces results where those axons terminate in their turn.

The *lower* motor centers, called also reflex centers, are located in the cord or brain stem, and their nerve cells give

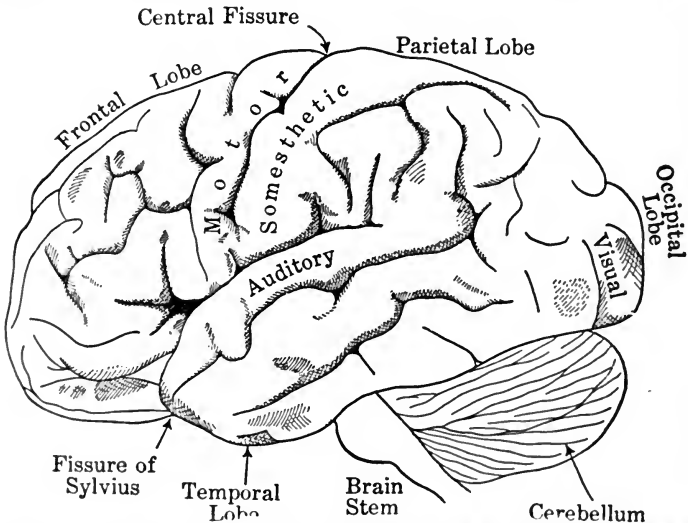
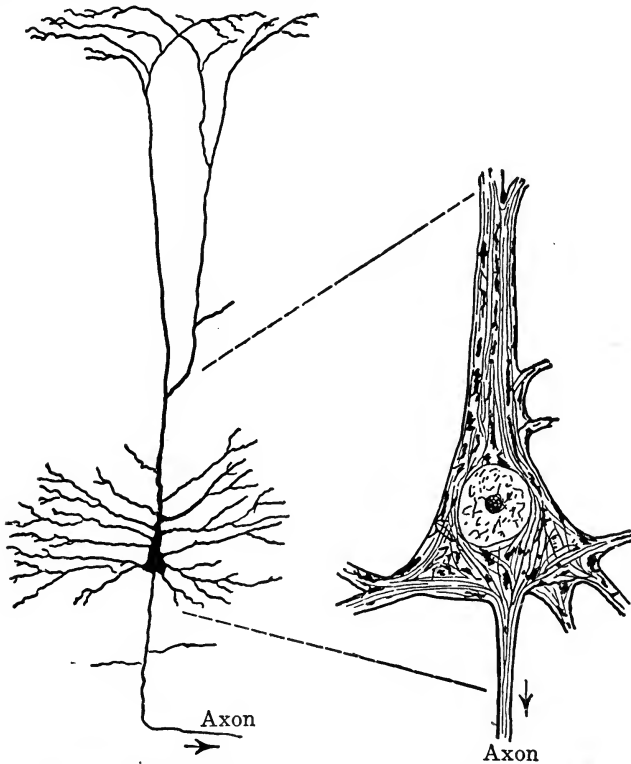

FIG. 12.—Side view of the left hemisphere of the brain, showing the motor and sensory areas (for the olfactory area, see Fig. 18). The visual area proper, or “visuo-sensory area,” lies just around the corner from the spot marked “Visual,” on the middle surface of the hemisphere, where it adjoins the other hemisphere.

rise to the axons that form the motor nerves and connect with the muscles and glands. A muscle is thrown into action by nerve currents from its lower motor center.

The principal *higher* motor center is the “motor area” of the brain, located in the cortex or external layer of gray matter, in the cerebrum. More precisely, the motor area is a long, narrow strip of cortex, lying just forward of what is called the “central fissure” or “fissure of Rolando”.

If you run your finger over the top of the head from one side to the other, about halfway back from the forehead, the motor areas of the two cerebral hemispheres will lie close under the path traced by your finger. The motor area in



Giant pyramid cell
from the motor area
of the cerebral cortex,
magnified 35 diameters

Cell body of same
further magnified

FIG. 13.—(After Cajal.) Type of the brain cells that most directly control muscular movement.

the right hemisphere is connected with the left half of the cord and so with the muscles of the left half of the body; the motor area of the left hemisphere similarly affects

the right half of the body. Within the motor area are centers for the several limbs and other motor organs. Thus, at the top, near the middle line of the head (and just about where the phrenologists located their "bump of veneration"!), is the center for the legs; next below and to the side is the center for the trunk, next that for the arm, next

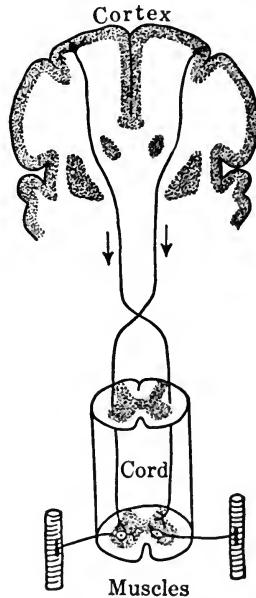

FIG. 14.—The nerve path by which the motor area of the cortex influences the muscles. The upper part of this path, consisting of axons issuing from the giant pyramids of the motor area and extending down into the spinal cord, is the pyramidal tract. The lower part of the path consists of axons issuing from the motor cells of the cord and extending out to the muscles. The top of the figure represents a vertical cross-section of the brain, such as is given, on a larger scale, in Fig. 18.

that for head movements, and at the bottom, not far from the ears, is the center for tongue and mouth.

The largest nerve cells of all are found in the motor area, and are called, from their shape, the "giant pyramids". They have large dendrites and very long axons, which latter,

running in a thick bundle down from the cortex through the brain stem and cord, constitute the "pyramidal tract", the principal path of communication from the cerebrum to the lower centers. The motor area of the brain has no direct connection with any muscle, but acts through the pyramidal tract on the lower centers, which in turn act on the muscles.

HOW THE BRAIN PRODUCES MUSCULAR MOVEMENTS

The motor area is itself aroused to action by nerve currents entering it through axons coming from other parts of the cortex; and it is by way of the motor area that any other part of the cortex produces bodily movement. There are a few exceptions, as, for example, the movements of the eyes are produced generally by the "visual area" acting directly on the lower motor centers for the eye in the brain stem; but, in the main, any motor effect of brain action is exerted through the motor area. The motor area, as already mentioned, acts on the lower motor centers in the cord and brain stem, and these in turn on the muscles; but we must look into this matter a little more closely.

A lower motor center is a group of motor and central neurones, lying anywhere in the cord or brain stem, and capable of directly arousing a certain coördinated muscular movement. One such unit gives flexion of the leg, another gives extension of the leg, a third gives the rapid alternation of flexion and extension that we see in the scratching movement of the dog. Such a motor center can be aroused to activity by a sensory stimulus, and the resulting movement is then called a reflex.

The lower center can be aroused in quite another way, and that is by nerve currents coming from the brain, by way of the motor area and the pyramidal tract. Thus flexion of the leg can occur voluntarily as well as reflexly. The same

muscles, and the same motor neurones, do the job in either case. In the reflex, the lower center is aroused by a sensory nerve, and in the voluntary movement by the pyramidal tract.

The story is told of a stranger who was once dangling his legs over the edge of the station platform at a small backwoods town, when a native called out to him "Hist!" (hoist), pointing to the ground under the stranger's feet. He "histed" obediently, which is to say that he voluntarily threw into play the spinal center for leg flexion; and then, looking down, saw a rattler coiled just beneath where his feet had been hanging. Now even if he had spied the rattler first, the resulting flexion, though impulsive and involuntary, would still have been aroused by way of the motor area and the pyramidal tract, since the movement would have been a response to *knowledge* of what that object was and signified, and knowledge means action by the cerebral cortex, which we have seen to affect movement through the medium of the motor area. But if the snake had made the first move, the same leg movement on the man's part, made now in response to the painful sensory stimulus, would have been the flexion reflex.

FACILITATION AND INHIBITION

Not only can the motor area call out essentially the same movements that are also produced reflexly, but it can prevent or *inhibit* the execution of a reflex in spite of the sensory stimulus for the reflex being present, and it can reinforce or *facilitate* the action of the sensory stimulus so as to assist in the production of the reflex. We see excellent examples of cerebral facilitation and inhibition in the case of the knee jerk. This sharp forward kick of the foot and lower leg is aroused by a tap on the tendon running in front

of the knee. Cross the knee to be stimulated over the other leg, and tap the tendon just below the knee cap, and the knee jerk appears. So purely reflex is this movement that it cannot be duplicated voluntarily; for, though the foot can of course be voluntarily kicked forward, this voluntary movement does not have the suddenness and quickness of the true reflex. For all that, the cerebrum can exert an influence on the knee jerk. Anxious attention to the knee jerk inhibits it; gritting the teeth or clenching the fist reinforces it. These are cerebral influences acting by way of the pyramidal tract upon the spinal center for the reflex.

Thus the cortex ^{can} control the reflexes. Other examples of such control are seen when you prevent for a time the natural regular winking of the eyes by voluntarily holding them wide open, or when, carrying a hot dish which you know you must not drop, you check the flexion reflex which would naturally pull the hand away from the painful stimulus. The young child learns to control the reflexes of evacuation, and gradually comes to have control over the breathing movements, so as to hold his breath or breathe rapidly or deeply at will, and to expire vigorously in order to blow out a match.

The coughing, sneezing and swallowing reflexes likewise come under voluntary control. In all such cases, the motor area facilitates or inhibits the action of the lower centers.

SUPER-MOTOR CENTERS IN THE CORTEX

Another important effect of the motor area upon the lower centers consists in combining their action so as to produce what we know as skilled movements. It will be remembered that the lower centers themselves give coördinated movements, such as flexion or extension of the whole limb; but still higher coördinations result from cerebral control.

When the two hands, though executing different movements, work together to produce a definite result, we have coördination controlled by the cortex. Examples of this are seen in handling an ax or bat, or in playing the piano or violin. A

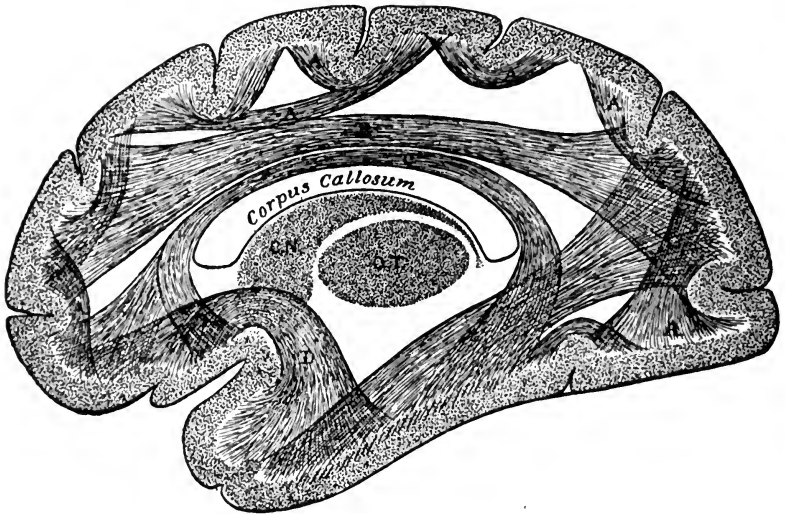

FIG. 15.—(From Starr.) Axons connecting one part of the cortex with another. The brain is seen from the side, as if in section. At "A" are shown bundles of comparatively short axons, connecting near-by portions of the cortex; while "B," "C," and "D" show bundles of longer axons, connecting distant parts of the cortex with one another. The "Corpus Callosum" is a great mass of axons extending across from each cerebral hemisphere to the other, and enabling both hemispheres to work together. "O. T." and "C. N." are interior masses of gray matter, which can be seen also in Fig. 18. "O. T." is the thalamus, about which more later.

movement of a single hand, as in writing or buttoning a coat, may also represent a higher or cortical coördination.

Now it appears that the essential work in producing these higher coördinations of skilled movement is performed not by the motor area, but by neighboring parts of the cortex, which act on the motor area in much the same way as the motor area acts on the lower centers. Some of these

skilled-movement centers, or super-motor centers, are located in the cortex just forward of the motor area, in the adjacent parts of the frontal lobe. Destruction of the cortex there, through injury or disease, deprives the individual of some of his skilled movements, though not really paralyzing him. He can still make simple movements, but not the complex movements of writing or handling an instrument.

It is a curious fact that the left hemisphere, which exerts control over the movements of the right hand and right side of the body generally, also plays the leading part in skilled movements of either hand. This is true, at least, of right-handed persons; probably in the left-handed the right hemisphere dominates.

Motor power may be lost through injury at various points in the nervous system. Injury to the spinal cord, destroying the lower motor center for the legs, brings complete paralysis. Injury to the motor area or to the pyramidal tract does not destroy reflex movement, but cuts off all voluntary movement and cerebral control. Injury to the "super-motor centers" causes loss of skilled movement, and produces the condition of "apraxia", in which the subject, though knowing what he wants to do, and though still able to move his limbs, simply cannot get the combination for the skilled act that he has in mind.

SPEECH CENTERS

Similar to apraxia is "aphasia" or loss of ability to speak. It bears the same relation to true paralysis of the speech organs that hand apraxia bears to paralysis of the hand. Through brain injury it sometimes happens that a person loses his ability to speak words, though he can still make vocal sounds. The cases differ in severity, some retaining the ability to speak only one or two words which

from frequent use have become almost reflex (swear words, sometimes, or "yes" and "no"), while others are able to pronounce single words, but can no longer put them together fluently into the customary form of phrases and sen-

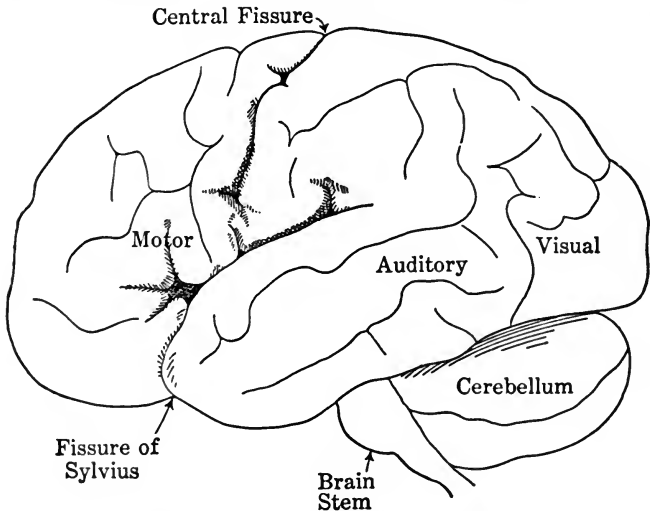

FIG. 16.—Side view of the left hemisphere, showing the location of the "speech centers." The region marked "Motor" is the motor speech center, that marked "Auditory" the auditory speech center, and that marked "Visual" the visual speech center.

tences, and still others can utter simple sentences, but not any connected speech.

In pure cases of *motor aphasia*, the subject knows the words he wishes to say, but cannot get them out. The brain injury here lies in the frontal lobe in the left hemisphere, in right-handed people, just forward of the motor area for the mouth, tongue and larynx. This "motor speech center" is the best-known instance of a super-motor center. It coördinates the elementary speech movements into the combinations called words; and perhaps there is no other motor performance so highly skilled as this of speaking. It is acquired so early in life, and practised so constantly, that

we take it quite as a matter of course, and think of a word as a simple and single movement, while in fact even a short word, as spoken, is a complex movement requiring great motor skill.

There is some evidence that the motor speech center extends well forward into the frontal lobe, and that the front part of it is related to the part further back as this is to the motor area back of it. That is to say, the back of the speech center combines the motor units of the motor area into the skilled movements of speaking a word, while the more forward part of the speech center combines the word movements into the still more complex movement of speaking a sentence. It is even possible that the very front part of the speech center has to do with those still higher combinations of speech movements that give fluency and real excellence of speaking.

THE AUDITORY CENTERS

Besides the motor aphasia, just mentioned, there is another type, called *sensory aphasia*, or, more precisely, auditory aphasia. In pure auditory aphasia there is no inability to pronounce words or even to speak fluently, but there is, first, an inability to "hear words", sometimes called word deafness, and there is often also an inability to find the right words to speak, so that the individual so afflicted, while speaking fluently enough and having sense in mind, misuses his words and utters a perfect jargon. One old gentleman mystified his friends one morning by declaring that he must go and "have his umbrella washed", till it was finally discovered that what he wanted was to have his hair cut.

The cortical area affected in this form of aphasia is located a little further back on the surface of the brain than

the motor speech center, being close to the auditory area proper. The latter is a small cortical region in the temporal lobe, connected (through lower centers) with the ear, and is the only part of the cortex to receive nerve currents from the organ of hearing. The auditory area is, indeed, the organ of hearing, or an organ of hearing, for without it the individual is deaf. He may make a few reflex responses to loud noises, but, consciously, he does not hear at all; he has no auditory sensations.

In the immediate neighborhood of the auditory area proper (or of the "auditory-sensory area", as it may well be called), are portions of the cortex intimately connected by axons with it, and concerned in what may be called auditory perceptions, i.e., with recognizing and understanding sounds. Probably different portions of the cortex near the auditory-sensory center have to do with different sorts of auditory perception. At least, we sometimes find individuals who, as a result of injury or disease affecting this general region, are unable any longer to follow and appreciate music. They cannot "catch the tune" any longer, though they may have been fine musicians before this portion of their cortex was destroyed. In other cases, we find, instead of this music deafness, the word deafness mentioned just above.

The jargon talk that so often accompanies word deafness reminds us of the fact that speech is first of all auditory to the child. He understands what is said to him before he talks himself, and his vocabulary for purposes of understanding always remains ahead of his speaking vocabulary. It appears that this precedence of auditory speech over motor remains the fact throughout life, in most persons, and that the auditory speech center is the most fundamental of all the speech centers, of which there is one more not yet mentioned, used in reading.

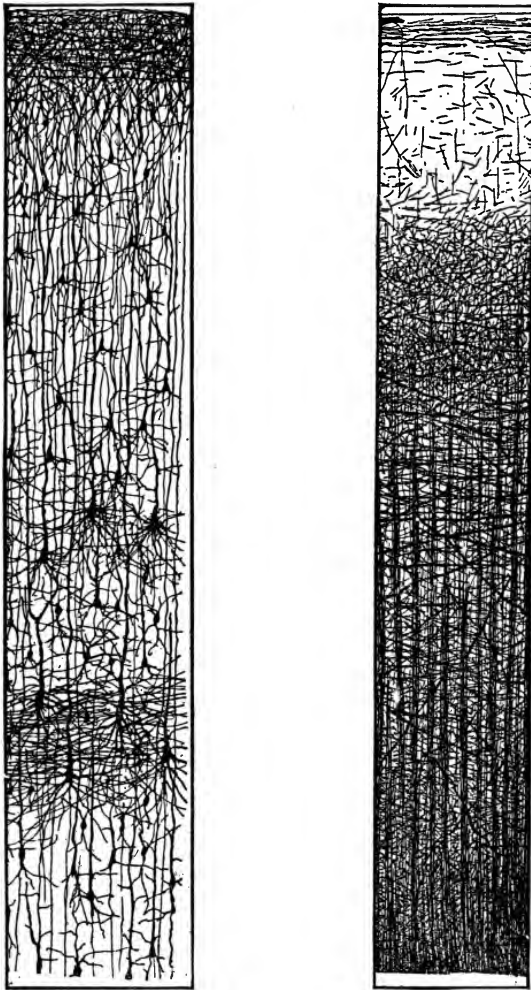

FIG. 17.—(From Cajal.) Magnified sections through the cortex, to show the complexity of its inner structure. One view shows nerve cells and their dendrites, with only a few axons, while the other shows axons, outgoing and incoming, and some of their fine branches. Imagine one view superimposed upon the other, and you get some idea of the intricate interweaving of axons and dendrites that occurs in the cortex.

THE VISUAL CENTERS

There is a visual-sensory area in the occipital lobe, at the back of the brain, that is connected with the eye in the same way as the auditory center is connected with the ear. With-

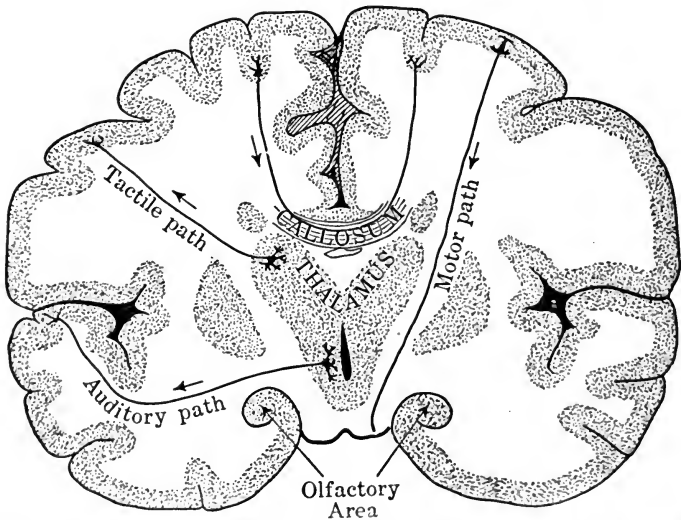

FIG. 18.—Vertical cross-section through the brain, showing the cortex on the outside, the thalamus and other interior masses of gray matter, some of the paths to and from the cortex, and the callosum or bridge of axons connecting the two cerebral hemispheres. The "Motor path" is the pyramidal tract, only the beginning of which is shown here, its further course being indicated in Fig. 14.

out it, the individual still shows the pupillary reflex to light, but has no sensations of sight. He is blind.

This visual-sensory area occupies only a small portion of the occipital lobe, and yet practically the whole lobe is concerned with vision. Some portions of the lobe are concerned in perceiving words in reading, and without them the individual is "word blind". Other portions are concerned in perceiving (recognizing, understanding) seen objects, and without them the individual is "object blind". Other por-

tions are concerned in perceiving color relations, and still other portions in perceiving spatial relations through the sense of sight and so knowing where seen objects are and being able to guide one's movements by sight.

CORTICAL CENTERS FOR THE OTHER SENSES

There is an olfactory area in a rather secluded part of the cortex, and this is related to the sense of smell in the same general way. Probably there is a similar taste center, but it has not been definitely located. Then there is a large and important area called the "somesthetic", connected with the body senses generally, i.e., chiefly with the skin and muscle senses. This area is located in a narrow strip just back of the central fissure, extending parallel to the motor area which lies just in front of the fissure, and corresponding part for part with it, so that the sensory area for the legs lies just behind the motor area for the legs, and so on. Destruction of any part of this somesthetic area brings loss of the sensations from the corresponding part of the body.

Just behind this direct sensory center for the body, in the parietal lobe, are portions of the cortex concerned in perceiving facts by aid of the body senses. Perception of size and shape by the sense of touch, perception of weight by the muscle sense, perception of degrees of warmth and cold by the temperature sense, are dependent on the parietal lobe and disappear when the cortex of this region is destroyed. It appears that there is a sort of hierarchy of centers here, as in the motor region and probably also in the visual and auditory regions. Skill in handling objects is partly dependent on the "feel" of the objects and so is impaired by injuries to the parietal lobe, as well as by injury to the frontal lobe; and knowing how to manage a fairly complex situation, as in lighting a fire when you have the various

materials assembled before you, seems also to depend largely on this part of the cortex.

LOWER SENSORY CENTERS

As already indicated, no portion of the cortex, not even the sensory areas, is directly connected with any sense organ. The sensory axons from the skin, for example, terminate in the spinal cord, in what may be called the lowest sensory

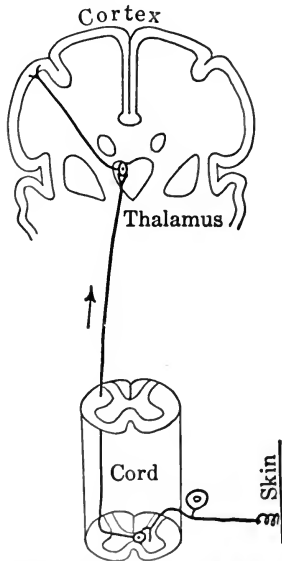

FIG. 19.—Sensory path from the skin of any portion of the trunk or limbs. The path consists of three neurones, the cell body of the first lying just outside the spinal cord, that of the second lying in the cord, and that of the third lying in the thalamus. The last part of this path is the "Tactile path," shown in Fig. 18.

centers. Here are nerve cells whose axons pass up through the cord and brain stem to the thalamus or interbrain, where they terminate in a second sensory center. And cells here send their axons up to the somesthetic area of the cortex.

The thalamus is remarkable as an intermediate center for all the senses, except smell; but exactly what is accomplished by this big intermediate sensory center remains rather a mystery, though it certainly appears that the thalamus has something to do with feeling and emotion.

THE CEREBELLUM

Regarding the cerebellum, there is much knowledge at hand, but it is difficult to give the gist of it in a few words. On the one hand, the cerebellum receives a vast number of axons from the lower sensory centers; while, on the other hand, it certainly has nothing to do with conscious sensation or perception. Its use seems to be motor. It has much to do with maintaining the equilibrium of the body, and probably also with maintaining the steadiness and general efficiency of muscular contraction. Though it has no known sensory or intellectual functions, it is very closely connected with the cerebrum, receiving a tremendous bundle of axons from different parts of the cerebrum, by way of the brain stem. Possibly these are related to motor activity. The phrenologists taught that the cerebellum was the center for the sexual instinct, but there is no evidence in favor of this guess.

DIFFERENT LEVELS OF REACTION

Let a noise strike the ear and start nerve currents in along the auditory nerve, passing through the lowest and intermediate centers and reaching the auditory-sensory area of the cortex. When this last is aroused to activity, we have a sensation of sound, which is the first conscious reaction to the external stimulus. Axons running from the auditory-sensory to the near-by cortex give a perception of some fact indicated by the external stimulus, and this perception is a

second and higher conscious reaction, which, to be sure, ordinarily occurs so quickly after the first that introspection cannot distinguish one as first and the other as second; but the facts of brain injury, already mentioned, enable us to draw the distinction. The perceived fact may call up a mental image, or a recognition of some further fact less directly signified by the noise; these would be reactions of still higher order. Much of the cortex is apparently not very directly connected with either the sensory or the motor areas, and probably is concerned somehow in the recognition of facts that are only very indirectly indicated by any single sensory stimulus, or with the planning of actions that only indirectly issue in muscular movement.

On the sensory and intellectual side, the higher reactions follow the lower: sensation arouses perception and perception thought. On the motor side, the lower reactions are aroused by the higher. Thus the speech center arouses the motor centers for the speech organs, combining the action of these into the speaking of a word; and in a similar way, it seems, the intention to speak a sentence expressing a certain meaning acts as a stimulus to call up in order the separate words that make the sentence. A general plan of action precedes and arouses the particular acts and muscular movements that execute the plan.

EXERCISES

1. Outline of the chapter. Fill in sub-topics under each of the following heads:

- A. Mental processes of all kinds are reactions.
- B. The stimulus that directly arouses a mental process is often "central".
- C. Brain activities of all sorts influence the muscles by way of the motor area and the lower motor centers.
- D. Brain action in skilled movement.
- E. Brain action in speech.
- F. Brain action in sensation.
- G. Brain action in recognizing seen or heard objects.
- H. Relations of reactions of different levels.

2. Define and illustrate these classes of stimuli:

- A. Peripheral:
 - (1) External.
 - (2) Internal.
- B. Central.

3. Show by a diagram how one cortical center arouses another. Compare the diagram in Fig. 9, p. 37.

4. Facilitation of the patellar reflex or "knee jerk". Let your subject sit with one leg hanging freely from the knee down. With the edge of your hand strike the patellar tendon just below the knee cap. (a) Compare the reflex movement so obtained with a voluntary imitation by the subject. Which is the quicker and briefer? (b) Apply a fairly strong auditory stimulus (a sudden noise) a fraction of a second before the tap on the tendon, and see whether the reflex response is reinforced. (c) Ask the subject to clench his fists or grit his teeth, and tap the tendon as he does so. Reinforcement? (d) Where is the reflex center for the patellar reflex, and whence comes the reinforcing influence?

5. Construct a diagram showing the different centers and connections involved in making the skilled movement of writing; and consider what loss of function would result from destruction of each of the centers.

REFERENCES

Herrick's *Introduction to Neurology*, 1918, Chapter XX, on the "Functions of the Cerebrum".

Stile's *Nervous System and Its Conservation*, Chapters X, XI and XII.

CHAPTER IV

TENDENCIES TO REACTION

HOW MOTIVES INFLUENCE BEHAVIOR, AND HOW THEY
FIT INTO A PSYCHOLOGY WHICH SEEKS TO ANALYZE
BEHAVIOR INTO REACTIONS.

One advantage of basing our psychology on *reactions* is that it keeps us "close to the ground", and prevents our discussions from sailing off into the clouds of picturesque but fanciful interpretation. Psychology is very apt to degenerate into a game of blowing bubbles, unless we pin ourselves down to hard-headed ways of thinking. The notion of a reaction is of great value here, just because it is so hard-headed and concrete. Whenever we have any human action before us for explanation, we have to ask what the stimulus is that arouses the individual to activity, and how he responds. Stimulus-response psychology is solid, and practical as well; for if it can establish the laws of reaction, so as to predict what response will be made to a given stimulus, and what stimulus can be depended on to arouse a desired response, it furnishes the "knowledge that is power". Perhaps no more suitable motto could be inscribed over the door of a psychological laboratory than these two words, "Stimulus-Response."

Such a motto would not frighten away the modern introspectionists, for they, no less than the behaviorists, could find a congenial home in a stimulus-response laboratory. They would begin by studying sensations, and, advancing to more complex responses, would observe the conscious processes entering into the response.

But, however useful the reaction may be as affording a sound basis for psychological study, we must not allow it to blind our eyes to any of the real facts of mental life; and, at first thought, it seems as if *motives, interests* and *purposes* did not fit into the stimulus-response program. Many



FIG. 20.—The symbol of stimulus-response psychology. *S* means the stimulus, and *R* the response. The line between is the connection from stimulus to response.

hard-headed psychologists have fought shy of such matters, and some have flatly denied them any place in scientific psychology. But let us see.

Suppose we are looking out on a city street during the noon hour. We see numbers of people who—lunch over, nothing to do till one o'clock!—are standing or walking about, looking at anything that chances to catch their eye, waving their hands to friends across the street, whistling to a stray dog that comes past, or congregating about an automobile that has broken down in the crowded thoroughfare. These people are responding to stimuli, obviously enough, and there is no difficulty in fitting their behavior into the stimulus-response scheme.

But here comes some one who pays little attention to the sights and sounds of the street, simply keeping his eyes open enough to avoid colliding with any one else. He seems in a hurry, and we say of him, "He must have business on hand; he has to keep an appointment or catch a train". He is not simply responding to the stimuli that come to him, but has some purpose of his own that directs his movements.

Here is another who, while not in such a hurry, is not idling by any means, since he peers closely at the faces of the men, neglecting the women, and seems to be looking for some one in particular; or, perhaps, he neglects men and

women alike, and looks anxiously at the ground, as if he had lost something. Some inner motive shuts him off from most of the stimuli of the street, while making him extra responsive to certain sorts of stimuli.

PURPOSIVE BEHAVIOR

Now it would be a great mistake to rule these purposeful individuals out of our psychology. We wish to understand busy people as well as idlers. What makes a man busy is some inner purpose or motive. He still responds to present stimuli—otherwise he would be in a dream or trance and out of all touch with what was going on about him—but his actions are in part controlled by an inner motive.

To complete the foundations of our psychology, then, we need to fit purpose into the general plan of stimulus and response. At first thought, purpose seems a misfit here, since—

First, a purpose is an inner force, whereas what arouses a response should be a stimulus, and typically an external stimulus. We do not wish to drop back into the old "self-activity" psychology, which thought of the individual as originating his acts from within himself. But if we could show that a purpose is itself an inner response to some external stimulus, and acts in its turn as a "central stimulus" to further reactions, this difficulty would disappear.

Second, while a typical reaction, like the reflex or the simple reaction of the experiment, is prompt and over with at once, a purpose persists. It keeps the busy man, in our illustration, hurrying all the way down the street and around the corner and how much farther we cannot say. It is very different from a momentary response, or from a stimulus that arouses a momentary response and nothing more.

Third, what persists, in purposive behavior, is the tend-

ency towards some end or goal. The purposeful person wants something he has not yet got, and is striving towards some future result. Whereas a stimulus pushes him from behind, a goal beckons to him from ahead. This element of action directed towards some end is absent from the simple response to a stimulus.

In short, we have to find room in our stimulus-response psychology for action persistently steered in a certain direction by some cause acting from within the individual.

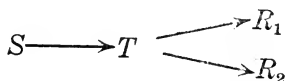

FIG. 21.—The stimulus-response scheme complicated to allow for the existence of *T*, an inner motive or tendency, which, aroused by an external stimulus, itself arouses a motor response. If the reaction-tendency were linked so firmly to a single response as to arouse that response with infallible certainty and promptness, then it would be superfluous for psychology to speak of a tendency at all. But often quite a series of responses, *R*₁, *R*₂, etc., follows upon a single stimulus, all tending towards the same end-result, such as escape; and then the notion of a “tendency” is by no means superfluous.

We must find room for *internal* states that *last* for a time and *direct* action. In addition, we sometimes, though not always, need to find room for conscious foreknowledge of the goal towards which the action is directed.

“Purpose” is not the best general term to cover all the internal factors that direct activity, since this word rather implies foresight of the goal, which demands the intellectual ability to imagine a result not present to the senses. This highest level of inner control over one’s behavior had best be left for consideration in later chapters on imagination and will. There are two levels below this. In the middle level, the individual has an inner steer towards a certain result, though without conscious foresight of that result. At the lowest level, we can scarcely speak of the individual as being directed towards any precise goal, but still his in-

ternal state is such as to predispose him for certain reactions and against other reactions.

The lowest level, that of organic states, is typified by fatigue. The middle level, that of internal steer, is typified by the hunting dog, striving towards his prey, though not, as far as we know, having any clear idea of the result at which his actions are aimed. The highest level, that of conscious purpose, is represented by any one who knows exactly what he wants and means to get.

No single word in the language stands out clearly, as the proper term to cover all three levels. "Motives" would serve, if we agree at the outset that a motive is not always clearly conscious or definite, but may be any inner state or force that drives the individual in a given direction. "Wants" or "needs" might be substituted for "motives", and would apply better than "motives" to the lowest of our three levels. "Tendencies", or "tendencies to reaction", carries about the right meaning, namely that the individual, because of his internal state, tends towards a certain action. "Determining tendencies" (perhaps better, "directive tendencies") is a term that has been much used in psychology, with the meaning that the inner tendency determines or directs behavior. Much used also are "adjustment" and "mental set", the idea here being to liken the individual to an adjustable machine which can be set for one or another sort of work. Often "preparation" or "readiness for action" is the best expression.

ORGANIC STATES THAT INFLUENCE BEHAVIOR

Beginning at the lowest of our three levels, let us observe not even the simplest animal, but a single muscle. If we give a muscle electric shocks as stimuli, it responds to each shock by contracting. To a weak stimulus, the response is weak;

to a strong stimulus, strong. But now let us apply a long series of equal shocks of moderate intensity, one shock every two seconds. Then we shall get from the muscle what is called a "fatigue curve", the response growing weaker and weaker, in spite of the continued equality of the stimuli. How is such a thing possible? Evidently because the inner condition of the muscle has been altered by its long-continued activity. The muscle has become fatigued, and physiologists, examining into the nature of this fatigue, have found the muscle to be poisoned by "fatigue substances" produced by its own activity. Muscular contraction depends on the

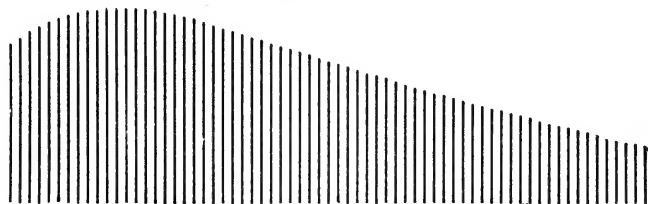

FIG. 22.—Fatigue curve of a muscle. The vertical lines record a series of successive contractions of the muscle, and the height of each line indicates the force of the contraction. Read from left to right.

oxidation of fuel, and produces oxidized wastes, of which carbon dioxide is the best known; and these waste products, being produced in continued strong activity faster than the blood can carry them away, accumulate in the muscle and partially poison it. The "organic state" is here definitely chemical.

This simple experiment is worth thinking over. Each muscular contraction is a response to an electric stimulus, but the force of the contraction is determined in part by the internal state of the muscle. Fatigue is an *inner* state of the muscle that *persists* for a time (till the blood carries away the wastes), and that *predisposes* the muscle *towards* a certain kind of response, namely, weak response. Thus the three characteristics of purposive behavior that seemed so

difficult to fit into the scheme of stimulus and response are all here in a rudimentary form.

But notice this fact also: the inner condition of *muscular fatigue is itself a response* to external stimuli. It is part and parcel of the total muscular response to a stimulus. The total response includes an internal change of condition, which, persisting for a time, is a factor in determining how the muscle shall respond to later stimuli. These facts afford, in a simple form, the solution of our problem.

Before leaving the muscle, let us take note of one further fact. If you examine the "fatigue curve" closely, you will see that a perfectly fresh muscle *gains* in strength from its first few responses. It is said to "warm up" through exercise; and the inner nature of this warming up has been found to consist in a moderate accumulation of the same products which, in greater accumulation, produce fatigue. The warmed-up condition is then another instance of an "organic state".

There will be more to say of "organic states" when we come to the emotions. For the present, do not the facts already cited compel us to enlarge somewhat the conception of a reaction as we left it in the preceding chapters? Besides the external response, there is often an internal response to a stimulus, a changed organic state that persists for a time and has an influence on behavior. The motor response to a given stimulus is determined partly by that stimulus, and partly by the organic state left behind by just preceding stimuli. You cannot predict what response will be made to a given stimulus, unless you know the organic state present when the stimulus arrives.

PREPARATION FOR ACTION

At the second level, the inner state that partly governs the response is more neural than chemical, and is directed

specifically towards a certain end-result. As good an instance as any is afforded by the "simple reaction", described in an earlier chapter. If the subject in that experiment is to raise his finger promptly from the telegraph key on hearing a given sound, he must be *prepared*, for there is no permanent reflex connection between this particular stimulus and this particular response. You tell your subject to be ready, whereupon he places his finger on the key, and gets all ready for this particular stimulus and response. The response is determined as much by his inner state of readiness as by the stimulus. Indeed, he sometimes gets too ready, and makes the response before he receives the stimulus.

The preparation in such a case is more specific, less a general organic state, than in the previous cases of fatigue, etc. It is confined for the most part to the nervous system and the sense organ and muscles that are to be used. In an untrained subject, it includes a ~~conscious purpose~~ to make? the finger movement quickly when the sound is heard; but as he becomes used to the experiment he loses clear consciousness of what he is to do. He is, as a matter of fact, ready for a specific reaction, but all he is conscious of is a general readiness. He feels ready for what is coming, but does not have to keep his mind on it, since the specific neural adjustment has become automatic with continued use.

Examples of internal states of preparedness might be multiplied indefinitely, and it may be worth while to consider a few more, and try out on them the formula that has already been suggested, to the effect that preparation is an inner adjustment for a specific reaction, set up in response to some stimulus (like the "Ready!" signal), persisting for a time, and predisposing the individual to make the specified reaction whenever a suitable stimulus for it arrives. The preparation may or may not be conscious. It might be named "orientation" or "steer", with the meaning that

the individual is headed or directed towards a certain end-result. It is like so setting the rudder of a sailboat that, when a puff of wind arrives, the boat will respond by turning to the one side.

The runner on the mark, "set" for a quick start, is a perfect picture of preparedness. Here the onlookers can see the preparation, since the ready signal has aroused visible muscular response in the shape of a crouching position. It is not simple crouching, but "crouching to spring." But if the onlookers imagine themselves to be seeing the *whole* preparation—if they suppose the preparation to be simply an affair of the muscles—they overlook the established fact that the muscles are held in action by the nerve centers, and would relax instantly if the nerve centers should stop acting. The preparation is neural more than muscular. The neural apparatus is set to respond to the pistol shot by strong discharge into the leg muscles.

What the animal psychologists have called the *delayed reaction* is a very instructive example of preparation. An animal is placed before a row of three food boxes, all looking just alike, two of them, however, being locked while the third is unlocked. Sometimes one is unlocked and sometimes another, and the one which at any time is unlocked is designated by an electric bulb lighted above the door. The animal is first trained to go to whichever box shows the light; he always gets food from the lighted box. When he has thoroughly learned to respond in this way, the "delayed reaction" experiment begins. Now the animal is held while the light is burning, and only released a certain time after the light is out, and the question is whether, after this delay, he will still follow the signal and go straight to the right door. It is found that he will do so, provided the delay is not too long—how long depends on the animal. With rats the delay cannot exceed 5 seconds, with cats it can reach 18

seconds, with dogs 1 to 3 minutes, with children (in a similar test) it increased from 20 seconds at the age of fifteen months to 50 seconds at two and a half years, and to 20 minutes or more at the age of five years.

Rats and cats, in this experiment, need to keep their heads or bodies turned towards the designated box during the interval between the signal and the release; or else lose their orientation. Some dogs, however, and children generally, can shift their position and still, through some inner orientation, react correctly when released. The point of the experiment is that the light signal puts the animal or child into a state tending towards a certain result, and that, when that result is not immediately attainable, the state persists for a time and produces results a little later.

PREPARATORY REACTIONS

In the delayed reaction, the inner orientation does little during the interval before the final reaction, except to maintain a readiness for making that reaction; but often "preparatory reactions" occur before the final reaction can take place. Suppose you whistle for your dog when he is some distance off and out of sight. You give one loud whistle and wait. Presently the dog swings around the corner and dashes up to you. Now, what kept the dog running towards you after your whistle had ceased and before he caught sight of you? Evidently he was directed towards the end-result of reaching you, and this directing tendency governed his movements during the process. He made many preparatory reactions on the way to his final reaction of jumping up on you; and these preparatory reactions were, of course, responses to the particular trees he had to dodge, and the ditches he had to jump; but they were at the same time governed by the inner state set up in him by your

whistle. This inner state favored certain reactions and excluded others that would have occurred if the dog had not been in a hurry. He passed another dog on the way without so much as saying, "How d'ye do?" And he responded to a fence by leaping over it, instead of trotting around through the gate. That is to say, the inner state set up in him by your whistle *facilitated* reactions that were preparatory to the final reaction, and *inhibited* reactions that were not in that line.

A hunting dog following the trail furnishes another good example of a directive tendency. Give a bloodhound the scent of a particular man and he will follow that scent persistently, not turning aside to respond to stimuli that would otherwise influence him, nor even to follow the scent of another man. Evidently an inner neural adjustment has been set up in him predisposing him to respond to a certain stimulus and not to others.

The homing of the carrier pigeon is a good instance of activity directed in part by an inner adjustment, since, when released at a distance from home, he is evidently "set" to get back home, and often persists and reaches home after a very long flight. Or, take the parallel case of the terns, birds which nest on a little island not far from Key West. Of ten birds taken from their nests and transported on ship-board out into the middle of the Gulf of Mexico and released 500 miles from home, eight reappeared at their nests after intervals varying from four to eight days. How they found their way over the open sea remains a mystery, but one thing is clear: they persisted in a certain line of activity until a certain end-result was reached, on which this line of activity ceased.

One characteristic of tendencies that has not previously been mentioned comes out in this example. When a tendency has been aroused, the animal (or man) is tense and

restless till the goal has been reached, and then quiets down. The animal may or may not be clearly conscious of the goal, but he is restless till the goal has been attained, and his restlessness then ceases. In terms of behavior, what we see is a series of actions which continues till a certain result has been reached and then gives way to rest. Introspectively, what we feel (apart from any clear mental picture of the goal) is a restlessness and tenseness during a series of acts, giving way to relief and satisfaction when a certain result has been reached.

A hungry or thirsty animal is restless; he *seeks* food or drink, which means that he is making a series of preparatory reactions, which continues till food or drink has been found, and terminates in the end-reaction of eating or drinking.

WHAT THE PREPARATORY REACTIONS ACCOMPLISH

The behavior of a hungry or thirsty individual is worth some further attention—for it is the business of psychology to interest itself in the most commonplace happenings, to wonder about things that usually pass for matters of course, and, if not to find “sermons in stones”, to derive high instruction from very lowly forms of animal behavior. Now, what is hunger? Fundamentally an organic state; next, a sensation produced by this organic state acting on the internal sensory nerves, and through them arousing in the nerve centers an adjustment or tendency towards a certain end-reaction, namely, eating. Now, I ask you, if hunger is a stimulus to the eating movements, why does not the hungry individual eat at once? Why, at least, does he not go through the motions of eating? You say, because he has nothing to eat. But he could still make the movements; there is no physical impossibility in his making chewing and swallowing movements without the presence of food. Speak-

ing rationally, you perhaps say that he does not make these movements because he sees they would be of no use without food to chew; but this explanation would scarcely apply to the lower sorts of animal, and besides, you do not have to check your jaws by any such rational considerations. They simply do not start to chew except when food is in the mouth. Well, then, you say, chewing is a response to the presence of food in the mouth; and taking food into the mouth is a response to the stimulus of actually present food. The response does not occur unless the stimulus is present; that is simple.

Not quite so simple, either. Unless one is hungry, the presence of food does *not* arouse the feeding reaction; and even food actually present in the mouth will be spewed out instead of chewed and swallowed, if one is already satiated. Try to get a baby to take more from his bottle than he wants! Eating only occurs when one is *both* hungry *and* in the presence of food. Two conditions must be met: the internal state of hunger and the external stimulus of food; then, and then only, will the eating reaction take place.

Hunger, though a tendency to eat, does not arouse the eating movements while the stimulus of present food is lacking; but, for all that, hunger does arouse immediate action. It typically arouses the preparatory reactions of seeking food. Any such reaction is at the same time a response to some actually present stimulus. Just as the dog coming at your whistle was responding every instant of his progress to some particular object—leaping fences, dodging trees—so the dog aroused to action by the pangs of hunger begins at once to respond to present objects. He does not start to eat them, because they are not the sort of stimuli that produce this response, but he responds by dodging them or finding his way by them in his quest for food. The responses that the hungry dog makes to other objects than

food are preparatory reactions, and these, if successful, put the dog in the presence of food. That is to say, *the preparatory reactions provide the stimulus that is necessary to arouse the end-reaction.* They bring the individual to the stimulus, or the stimulus to the individual.

What we can say about the modus operandi of hunger, then, amounts to this: Hunger is an inner state and adjustment predisposing the individual to make eating movements

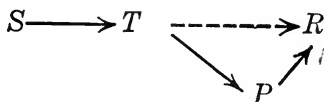

FIG. 23.—A stimulus arouses the tendency towards the end-reaction, *R*, but (as indicated by the dotted line), *T* is not by itself sufficient to arouse *R*; but *T* can and does arouse *P*, a preparatory reaction, and *P* (or some external result directly produced by *P*), cooperating with *T*, gives rise to *R*.

in response to the stimulus of present food; in the absence of food, hunger predisposes to such other responses to various stimuli as will bring the food stimulus into play, and thus complete the conditions necessary for the eating reaction. In general, *an aroused reaction-tendency predisposes the individual to make a certain end-reaction when the proper stimulus for that reaction is present; otherwise, it predisposes him to respond to other stimuli, which are present, by preparatory reactions that eventually bring to bear on the individual the stimulus required to arouse the end-reaction.*

Let us apply our formula to one more simple case. While reading in the late afternoon, I find the daylight growing dim, rise and turn on the electric light. The stimulus that sets this series of acts going is the dim light; the first, inner response is a need for light. This need tends, by force of habit, to make me turn the button, but it does not make me execute this movement in the air. I only make this movement when the button is in reaching distance. My first

reaction, rising from my chair, is preparatory and brings the button close enough to act as a stimulus for the hand reaction. The button within reach is not by itself sufficient to arouse the turning reaction, nor is the need for light alone sufficient. The two conditions must be present together, and the preparatory reaction is such that, given the need, the other condition will be met and the reaction then aroused.

WHAT A TENDENCY IS, IN TERMS OF NERVE ACTION

Very little need be added to our neural conception of a reaction in order to get a satisfactory conception of a tendency to reaction. Principally, we must add this fact, that a nerve center aroused to activity does not always discharge instantly and completely into the muscles, or into some other center, and come to rest itself. It does so, usually, in the case of a reflex, and in other momentary reactions; as when A makes you think of B, and B at once of C, and so on, each thought occupying you but a moment. But a tendency means the arousing of a nerve center under conditions which do not allow that center to discharge at once. The center remains in a condition of tension; energy is dammed up there, unable to find an outlet.

We have already seen what the conditions are that cause this damming up of energy. The center that is aroused tends to arouse in turn some lower motor center, but by itself does not have complete control over that lower center, since the lower center also requires a certain external stimulus in order to arouse it to the discharging point. Until the proper external stimulus arrives to complete the arousal of the lower center, the higher center cannot discharge its energy.

When there is an "organic state" present, such as hunger or thirst, this may act as a persistent stimulus to the sensory nerves and through them to the higher center in

question; and then we can readily understand how it is that the center remains active until the organic state is relieved. But where there is no such persistent organic stimulus, as there can scarcely be in the case of the bloodhound or of the man hurrying to a train or seeking in the crowd for a friend, there we have to suppose that a center, once aroused to activity and prevented from complete discharge, remains active by virtue of energy dammed up in itself. There is pretty good physiological evidence that this sort of thing is a fundamental fact; for there are certain rhythmical reflexes, like scratching or stepping, that, when started going by a momentary sensory stimulus, keep it up for a time after the stimulus has ceased. There seems to be no doubt that a nerve center, once aroused, may stay aroused for a time.

The "dammed-up energy" here is not to be confused with the "stored energy" spoken of under the head of reactions. We said, in that connection, that a stimulus released energy stored in the organism. That, however, was *potential* energy, dormant within the organism till aroused; but what we have here in mind is active or *kinetic* energy. Stored energy is like that of coal in the bin; dammed-up energy is like that of steam in the boiler.

Dammed-up energy in the nerve centers accounts for the persistence of a tendency to reaction after the stimulus has ceased. It accounts for the "delayed reaction" and similar cases. But how shall we account for preparatory reactions? We have a nerve center in an active state, tending to discharge into a certain lower motor center, but unable to do so because a peripheral stimulus is necessary, in addition, in order to arouse this lower center. Then we find the higher center discharging into *other* lower centers, and so giving rise to preparatory reactions. More precisely, what we find is that the higher center facilitates the response

of certain lower centers to their proper peripheral stimuli, while inhibiting the response of other lower centers to their appropriate stimuli. This is the same sort of thing that we observe in all control exerted by a higher center over a lower. It means that the higher center, besides its main line of connection with the lower center that will give the end-reaction, has minor lines of connection with certain other lower centers; some of these centers it facilitates and others it inhibits. These connections between the main and the subordinate centers may have been established by inborn nature, or by previous training, as will be explained in later chapters.

The action of the main center on the subordinate centers concerned in executing preparatory reactions does not relieve the tension in the main center. The dammed-up energy stays there till the proper stimulus is procured for arousing the end-reaction, and then escapes through its main channel of discharge, and the main center then finally comes to rest.

It may fairly be urged that no violence has been done to the general conception of a reaction by these additions, and also that with the additions the notion of a reaction has room for tendencies or inner adjustments. So that we conclude that stimulus-response psychology is adequate to the job, and will do justice to all forms of human behavior. It has a place for sensations, perceptions and thoughts, as we saw in the preceding chapter, and it has a place also for purposes, desires and motives generally.

MOTIVES

In the present chapter, desirous of "keeping close to the ground", we have said little of distinctively human motives. That will come later. In general, a motive is a tendency towards a certain end-result or end-reaction, a tendency which is itself aroused by some stimulus, and which

persists for a time because its end-reaction is not at once made. The end-reaction is not made at once because it can only be aroused by an appropriate stimulus, acting in conjunction with the motive. But the motive, persisting in its inner activity, facilitates reactions to certain stimuli and inhibits others. The reactions it facilitates are preparatory to the end-reaction, in that they provide the necessary conditions for that reaction to occur, which means that they bring to bear on the individual the necessary stimulus which can arouse the end-reaction. The restlessness that characterizes an individual driven by an inner motive gives way to rest and satisfaction when the end-result is reached.

Motives range from the primitive or primal, like hunger, to the very advanced, such as zeal for a cause. They range from the momentary, illustrated by the need for more light in reading, to the great permanent forces of life, like *amour propre* and *esprit de corps*. But the permanent motives are not always active; they sleep and are awakened again by appropriate stimuli.

In everyday speech we are apt to use the words "motive" and "reason" interchangeably, as in asking some one what his "motive", or what his "reason" is for doing so and so. A motive, however, is not necessarily a reason, nor a reason a motive. A reason is thought-out and conscious, which a motive need not be. On the other hand, a reason does not become a motive unless it takes hold of us and arouses a genuine tendency towards the planned result. You may prove to me, logically, the desirability of a course of action, but your reasons do not necessarily make me desire it. You can give a child excellent reasons for studying his lessons, but you have to stir some real motive of child life in order to get action. In the highest type of conduct, to be sure, motive and reason pull together, reason showing the way to the goal at which motive is aimed.

EXERCISES

1. Complete the following outline of the chapter, by filling in main headings to fit the subordinate headings that are given below:

- A. Scientific Psychology
- (1) It keeps close to the facts.
 - (2) It has room for introspective as well as behavior study.
 - (3) It can be applied practically.
- B. Stimulus and Response
- (1) A stimulus is typically external, a purpose internal.
 - (2) A stimulus typically acts for a moment, a purpose persists for some time.
 - (3) A stimulus is not directed towards a result, a purpose is so directed.
- C. Instincts
- (1) Organic or physiological states that predispose towards certain forms of behavior.
 - (2) Inner adjustments towards certain results, without foresight of the results.
 - (3) Conscious purpose.
- D. Instincts
- (1) They are aroused by stimuli.
 - (2) They persist for a time.
 - (3) They influence the response to other stimuli.
- E. Instincts
- (1) They are neural rather than chemical.
 - (2) They amount to a preparation or readiness for a certain response.
 - (3) They persist sometimes for only a few seconds, sometimes for many minutes at least.
- F. Instincts
- (1) A whole series of acts may be set going by a single stimulus.
 - (2) The series comes to an end when a certain result has been reached.
 - (3) Each act in the series is a response to some particular stimulus, and yet would not be aroused by that stimulus except for the active adjustment towards the end-result.

- (4) The end-result cannot be reached until a particular stimulus helps the adjustment to arouse the end-reaction.
- (5) The preliminary acts in the series bring the required stimulus that can give the end-reaction.

G. _____.

- (1) It may be kept active by a continuing peripheral stimulus.
- (2) It may be unable to discharge fully because its main path of discharge is blocked.

H. _____.

- (1) The main center has minor connections with other centers, in addition to its main path of discharge.
- (2) The persisting activity of the main center influences other centers by way of facilitation and inhibition.

2. Fill in the blanks in the following paragraph:

“A motive or (1) is a reaction that has not yet come off. It has been (2) by some stimulus, and it tends towards a certain (3), which however it is unable of itself to produce, but requires the assistance of another (4) which is not yet present. The motive gives rise to (5) responses, which, if (6), finally bring the required (7), and this, combined with the (8) arouses the (9), and so brings the whole (10) of acts to a close.”

3. Cite cases illustrating the importance of preparatory adjustment (a) for securing prompt reaction, and (b) for securing keen observation.

4. Cite a case where some need or desire gives rise to a series of preparatory reactions.

5. Cite a case where a need or desire leads to the omission (inhibition) of acts that would otherwise have occurred.

6. What is meant by the last sentence in the chapter?

7. An experiment on the “delayed reaction”. Take two sheets of paper, and on each write the letters A, B, C, D, E, and F, scattering them irregularly over the sheet. The task, in general, is now to take aim at one of the letters, while your hand, holding a pencil, is raised to the side of your head, and then to close the eyes and strike at the letter aimed for. First aim at A, and mark the point hit with an *a*, then the same with B, and so on. With the first sheet, strike as soon as you have got your aim and closed your eyes; but with the second sheet, aim, close your eyes, and count ten slowly before striking, keeping the eyes closed till the stroke has been made. Two sorts of observation should now be made: first, introspective—record at once what you can of the way you kept your aim during the delay. Second, objective—measure the errors, and determine how much the delay affected your aim. What conclusions can you draw from the experiment?

REFERENCES

On the "delayed reaction", see Walter S. Hunter, "The Delayed Reaction in Animals and Children", *Behavior Monographs*, No. 6, 1913. A brief summary of this work can also be found in Hunter's *General Psychology*, 1919, pp. 31-33.

On the homing of pigeons and terns, see Watson and Lashley, *An Historical and Experimental Study of Homing*, published by the Carnegie Institution of Washington, 1915.

Interesting examples of changed organic states affecting the behavior of unicellular animals are given by Jennings in his *Behavior of the Lower Organisms*, 1906, and by Margaret F. Washburn in *The Animal Mind*, 2nd edition, 1917, pp. 246-257.

CHAPTER V

NATIVE AND ACQUIRED TRAITS

SOME RESPONSES ARE PROVIDED BY NATURE, WHILE
OTHERS HAVE TO BE LEARNED BY EXPERIENCE

John Doe is a strongly built man, over six feet high, with big bones and muscles, erect, vigorous, with plenty of color in his face, dark-haired, blue-eyed, clean-shaven, with a scar on his cheek, broad face and large ears. He is easy-going, even-tempered, fond of children and also of women, rather slangy and even profane in his talk, has a deep, sonorous voice and can carry the bass in a chorus. He is handy with tools, can drive or repair an automobile, is a fairly good carpet salesman, but much prefers out-of-door work. Rather free in spending his money, he has never run into debt except on one occasion, which turned out badly for him. Which of these traits of John Doe are native and which are acquired? How far are his physical, mental and moral characteristics the result of his "original nature", and how far have they been ingrained in him or imposed upon him by his training and environment?

The distinction between native and acquired is clearest in the field of anatomy. Hair color and eye color are evidently native, and so, in the main, is the size of the body, though undoubtedly growth may be stunted by poor nutrition, and the individual fail to reach his "natural" height and weight. On the other hand, scars, tan, and the after-effects of disease or injury, are evidently acquired. Of movements, the native character of the reflexes has already been noted, and it is clear that skill in handling tools or man-

aging the voice is learned, though the individual may have a natural aptitude for these performances. Temperament and emotional traits we usually think of as belonging to a man's "nature", though we have to admit that a naturally cheerful disposition may be soured by ill treatment. On the other hand, while we reckon habits, such as profanity, or free spending, or an erect carriage, as belonging with the acquired traits, we know that some natures are prone to certain habits, and other natures to other habits. Thus the effects of "nature" and "experience" are almost inextricably interwoven in the behavior of an adult person.

Difficult as it certainly is to separate the native from the acquired in human action, the attempt must be made. We cannot dodge so fundamental a problem. Scientifically it is important as the starting-point of a genetic study; we must know where the individual starts in order to understand the course of his development. Practically it is important because there is reason to believe that native traits are deeply seated and not easily eradicated, even though they can be modified and specialized in different ways. If a habit is not simply a habit, but at the same time a means of gratifying some natural tendency, then it is almost imperative to find a substitute gratification in order to eliminate the habit. The individual's nature also sets limits beyond which he cannot be brought by no matter how much training and effort; and this is true of mental development as well as of physical.

THE SOURCE OF NATIVE TRAITS

"Native" means a little more than "congenital." A child may be born blind, having been infected by disease germs shortly before birth; he may be congenitally an idiot because of head injury during a difficult birth; or his mentality may have been impaired, during his uterine life, by

alcohol reaching his brain from a drunken mother. Such traits are congenital, but acquired. Native traits date back to the original constitution of the child, which was fully determined at the time when his individual life began, nine months before birth. The "fertilized ovum", formed by the combination of two cells, one from each of the parents, though microscopic in size and a simple sphere in shape, somehow contains the determiners for all the native or inherited traits of the new individual.

It is very mysterious, certainly. This microscopic, featureless creature is already a human individual, with certain of its future traits—those that we call "native"—already settled. It is a human being as distinguished from any other species, it is a white or colored individual, male or female, blonde or brunette, short or tall, stocky or slender, mentally gifted or deficient, perhaps a "born" musician or adventurer or leader of men. These and all other native traits are already determined and latent within it; and the only question, regarding such traits, is whether the environment is going to be such as to enable this young individual to live and mature and unfold what is latent within it.

REACTIONS APPEARING AT BIRTH MUST BE NATIVE

For the first few months of the individual's existence, sheltered as it is within the mother's body, there is no chance for any acquisition, except of certain abnormalities such as were alluded to above. What occurs during this prenatal period is natural development, not learning or any effect of experience. The traits displayed by the new-born child are, accordingly, native traits. His breathing, crying, starting at a noise, squirming, stretching, grasping, sucking and swallowing, and other movements made from birth on, are to be counted as native reactions, that is to say, as reac-

tions executed by sensory, muscular and nervous machinery that have become ready for use by the mere process of natural growth. This is the first and clearest sign of a native trait, that it shall appear at birth.

REACTIONS THAT CANNOT BE LEARNED MUST BE NATIVE

But native traits continue to make their appearance as the child's development proceeds after birth. Inherited anatomical traits, like stature and build, hair color, beard, and shape of nose, though certainly determined by native constitution, do not fully make their appearance till maturity. In fact, what does maturity mean, except that the natural characteristics have finally reached their complete development? And it is as true of internal structure as of external, that natural development, far from being complete at birth, keeps on till maturity. The neurones continue to grow, and their synapses in the nerve centers to become closer knit, just by virtue of natural growth; and thus reflex arcs, and other reaction machinery, one by one reach the ready-to-use stage during the individual's growing-up, especially during the first few years. With the growth to a functional condition of their sensori-neuro-muscular mechanisms, mental and motor reactions that are native, though not present at birth, make their appearance. The native intelligence of the child gradually unfolds, likewise his special native "gifts" and his inherited emotional and impulsive traits.

Of course it is more difficult to make sure that a trait is native when it does not appear till some time after birth, for the chance of acquiring it by a process of learning has to be taken into account. If you can so control the conditions under which the young individual grows as to eliminate the possibility of learning a certain act, then you can

make sure whether the act is acquired or provided by the native constitution.

EXPERIMENTAL DETECTION OF NATIVE REACTIONS

Take the question whether birds learn to fly or simply come to fly when their natural development has gone far enough. The newly hatched bird cannot fly; its muscles are not strong enough, its wings are not feathered, and its nerve mechanism for coördinating the wing movements has still some growth to make before being ready for use. But, under ordinary conditions, the young bird has some chance to *learn* flying, by watching the old birds fly and by trying and gradually getting the motion. The old birds, after a time, push the young ones from the nest and seem, to our eyes, to be teaching them to fly. Experiment enables us to decide the question. One of the earliest experiments in animal psychology was made by Spalding in 1873. He took newly hatched birds from the nest and shut each one separately in a little box that gave it no chance to stretch its wings or to see other birds fly. Here he fed and cared for them till the age at which flying usually begins, and then released them. Off they flew, skilfully managing wings and tail, swooping around the trees and soon disappearing from sight. A very successful experiment!—and conclusive. The little birds had had no chance to learn to fly, yet they flew. Flying must have come to them in the natural course of growth.

Compare with this experiment another one no less successful, though it turned out differently. To discover whether the song of the oriole is fixed by nature or learned by imitation, Scott took some little ones, just hatched, and brought them up away from older birds. After a time, when growth had advanced to a certain stage, the birds began

to sing. The elementary notes and rattles characteristic of the oriole made their appearance, but were combined in unusual ways, so that the characteristic song of the oriole did not appear, but a new song. When these birds had grown up in the laboratory, other new-hatched orioles were brought up with them, and adopted this new song; so that the laboratory became the center for a new school of oriole music. The experiment showed that the elements of the oriole's song were provided by nature, while the combination of these elements was acquired by imitation.

Probably this last is about the result one would get in the analogous case of human speech, if a similar experiment should be tried on children. Without an experiment, we have certain facts that point to a conclusion. The child uses his vocal organs from birth on; and before he reaches the age when he imitates the speech of others, he produces various vowels and consonants, and even puts them together into simple compounds, as "da-da" and "goo-goo." So far, deaf children do about the same as others, affording additional evidence that so much of speech is native. To get real speech, however, further combinations of the speech movements must be made, and the combinations (words) must have meaning attached to them. These higher achievements are evidently the result of learning, since the child uses the words that it hears spoken, and attaches the same meanings to them as people do about it. The child comes to speak the language of those about it, without regard to the speech of its ancestors. His "native language" is therefore acquired, though the elements of vocal utterance are truly native, and apparently are alike all over the world without regard to the various languages spoken.

IS WALKING NATIVE OR ACQUIRED?

As another example of this same general problem of distinguishing native from acquired reactions, and of the kind of evidence that throws light on the problem in the absence of direct experiment, let us consider the child's walking. Does the child learn to walk, or does it simply *come* to walk when its natural development has gone far enough? We think the child learns to walk because it begins very imperfectly and usually takes several weeks before it can be described as really walking of itself. We even think we teach it to walk, though when we examine our teaching we soon convince ourselves that we do not know *how* we walk, and that what we are doing with the baby is to stimulate and encourage him to walk, protect him from hurting himself, etc., rather than teaching him as we later teach the child to write. An experiment to settle the matter might be conducted along the lines of Spalding's experiment on the young birds. We might prevent the baby from making any attempt to walk till it had fully reached the normal age for walking, and then turn it loose and see whether it walked of itself.

Such an experiment has never been made under strict laboratory conditions; but here is a well-attested case that approximates to an experiment. A little girl of seven months, a very active child, seemed to want to get on her feet; but the doctor decided that her feet were too small to use, and directed that she be put back in long dresses. For four months she was kept in long dresses, and great care was exercised never to place her on the floor without them. Then, one day, she was set down without her dress, and immediately up she got and walked; and from that moment she was very agile on her feet.

Another rather different case, but tending towards the

same conclusion, is that of a little girl who, in contrast to the preceding, gave her parents some anxiety because, up to the age of seventeen months, she wouldn't walk. She would stand holding on, but not trust herself to her feet alone. One noon her father came in from his work and, removing his cuffs, laid them on the table. The little girl crept to the table, and raised herself to a standing position, holding on to the table. She then took a cuff in one hand, and inserted the other hand into it, thus, for the first time, standing unsupported. She put on the other cuff in like manner, and then marched across the room, as proud as you please. For a few days she could walk only with cuffs, but after that was able to dispense with them. There are a few other cases, differing in details, but agreeing on the main point, that the baby walked well on its first trial and went through nothing that could properly be interpreted as a process of learning.

It would really be very surprising if the human infant were left to learn locomotion for himself, while all other animals have this power by nature. Just because the human infant matures slowly, and learns a vast deal while maturing, is no reason for overlooking the fact that it does mature, i.e., that its native powers are gradually growing and reaching the condition of being ready for use. The most probable conception of "learning to walk," in the light of the evidence, is about as follows. At the age when the child's bones and muscles have become strong enough for walking, the nerve connections for coördinating this complex movement have also just about reached the stage of development when they are ready for business. The numerous synapses in the nerve centers that must be traversed by nerve currents in order to arouse the muscles to this particular act are not, we may suppose, all ready at the same instant, and it takes some little time for them to pass from

the stage when they will first conduct to the stage when, having grown more, they conduct perfectly. In other words, the neural mechanism for walking can function imperfectly before it can function perfectly. It takes several weeks of growth to pass from the barely functional condition to the fully functional condition; and it is during these weeks that the child seems to be learning to walk, while really his exercise of the partially developed neural mechanisms has no effect except to hasten their growth to some extent.

UNIVERSALITY AS A CRITERION OF NATIVE REACTIONS

The fundamental sign or criterion of a native trait, in accordance with what we have been saying, is that it shall make its appearance when there has been no chance to acquire it through experience. This is the one perfect criterion; but unfortunately it cannot always be applied, especially with a slowly maturing and much-learning species such as the human. We need other criteria, and one of some value is the criterion of *universality*.

Consider, for example, the attraction between the sexes, and ask whether this represents a native tendency, or whether each individual acquires it, as he does his "native language", by learning from his elders. Before the body reaches sexual maturity, there has been abundant opportunity for the quick-learning child to observe sex attraction in older people. Yet it is highly improbable that the liking for the other sex which he begins to show strongly in youth is simply an acquired taste. It is improbable because the attraction between the sexes is so universal not only among mankind but among birds and mammals and, indeed, practically throughout the animal kingdom.

Fighting is a similar case. Not so universal as the sex instinct, it still appears almost universally among birds and mammals.

The human individual is an animal, and some of his native traits are universal among animals. He is a vertebrate, and some of his traits, though not present in all animals, are universal among vertebrates. He is a mammal, with mammalian traits; a primate, with primate traits; a man with human traits; a Chinaman or Indian or European with racial traits; belongs to a more or less definite stock or breed within the race, and possesses the traits that are common to members of that stock; and the same with family traits. The criterion of universality, in the light of these facts, comes down to this: that *when all individuals having the same descent show a trait in common, that trait is to be regarded as belonging to their native constitution—unless evidence can be brought forward to the contrary.*

Smoking is universal among many Malay peoples, but we know, as a historical fact, that it was introduced among them after the discovery of America, not very many generations ago. Superstition is universal among some peoples, but we see the superstitious beliefs and practices taught by the older to the younger generation. Similarly with any specific language. It may very well be true in such cases that the universal practice appeals to some native tendency of the people; but the specific practice is handed down by tradition and not by inheritance.

SOME NATIVE TRAITS ARE FAR FROM BEING UNIVERSAL

Though the universality of a trait creates a certain presumption in favor of its being native, the opposite is not always true, for a trait may be native and yet appear in only a fraction of those who have a common descent. Eye color is certainly native, and yet one of two brothers may have blue eyes and the other brown. Mental deficiency runs in families, but usually some members of such families have

normal mentality. Genius is almost certainly a native trait, but it is the reverse of universal. The fact is that, along with certain traits that appear in all, the native constitution of a stock provides also for traits that appear only sporadically. Enough has been said to show that the criterion of universality is one that needs to be applied with judgment.

WHY ACQUIRED TRAITS DIFFER FROM ONE INDIVIDUAL TO ANOTHER

Acquired traits are on the whole much less universal, much more individual, than native traits. They are readjustments of the individual to environmental conditions; and, as the environment varies, so the adjustments vary, even when native traits are the same. Acquired traits are often specializations of the native traits, as any specific language is a specialization of the vocal utterances that are native and common to all men, and as the peculiar gait of an individual is a specialization of the universal walking movement. The gait differs with the environmental differences to which the individual has adapted himself, and will be different in one who has been accustomed to walk over rough ground and in one whose walking has been done on the city streets.

Acquired traits are not independent of native, but are developed on the basis of the native traits. They are acquired not by laying aside native tendencies and working out something entirely new, but by acting in accordance with the native tendencies and making such readjustments as the environment demands. The acquisition of mental traits is accomplished by the process of *learning*, and we shall later have abundant occasion to examine it in more detail.

WHAT MENTAL TRAITS ARE NATIVE?

For the present, let us simply take a brief survey of the mental field, and notice what types of reactions are native and what acquired. On the motor side, the reflexes are native, while habitual and skilled movements are acquired. On the sensory side, nature provides the use of the sense organs and the sensations immediately resulting from their stimulation. The baby responds to touch, warmth, cold, sound and light as soon as it is born, or practically so, and undoubtedly has the corresponding sensations. In other words, the rudiments of seeing, hearing, etc., are provided by nature. But when we say, "I see a dog", we mean more than that we are getting certain visual sensations; we mean that we see a known object or known sort of object. This implies recognition of the object, either as an individual thing or as one of a class; and this the baby can scarcely be supposed to do at first. He sees the dog to the extent that he responds by visual sensations to the light coming from the dog, but not to the extent that he recognizes the dog as a dog. In short, the *meanings* of sensations are acquired, though the sensations themselves are native.

Things come to be known by use of the senses, and when thus known are not only recognized when present, but also remembered and thought of when they are not present to the senses. Such memories and items of knowledge, dependent as they are on experience, are to be reckoned among the acquired reactions. Ideas or conceptions of things also belong here.

Of the emotions, some are called "primary" or native—anger and fear are examples—while others result from the compounding of these primary emotions and are therefore acquired. As people and things come to be known, emotional reactions become attached to them, and give what

are often named "sentiments", such as love for this person, contempt for that one, family pride, patriotism. These sentiments, bound up as they are with knowledge and ideas, are certainly acquired.

Closely akin to the primary emotions are the native impulses, as the impulse to eat, to cry, to laugh, to escape from danger, to resist external compulsion and to overcome obstacles. The native impulses are the raw material out of which the numerous acquired desires of child and adult are formed. One sort of native impulse is the impulse to notice or pay attention to certain sorts of stimuli. These native interests of the child give birth to the various specialized interests of the adult. The baby's attention to a bright light represents a native interest; the older child's fixing his eyes on a dark brown piece of chocolate represents an acquired interest which has developed in a way that is easy to understand.

Finally, we must count among the native traits of the individual his inherited aptitudes for certain kinds of work. One child shows a natural aptitude for music, another for acting, another for mathematics, another for mechanical things, another for language, and so on. As any of these "natural gifts" is present in some degree in nearly all members of the human family, and not to anything like the same degree in animals, they are the characteristically human traits. It is on the basis of such native aptitudes that each individual proceeds, through the processes of learning, to build up his various acquired abilities, such as the ability to sing, to speak a certain language, to add, to work with tools, to perform athletic feats, and to take part in social activities of various sorts.

Our next task will be to examine more closely the native equipment of man, and after that to take up the process of learning, which is the way reactions are acquired. First the native, then the acquired. The acquired is based upon

the native. Acquired reactions are indeed so numerous that we cannot attempt even to list them all, let alone examine each one separately; but we can at least study the *way* in which they are acquired. Native reactions are much less numerous, so that the student may hope to obtain a fairly comprehensive survey of this field, though, of course, without much detail.

The general plan of this book, then, is as follows. Up to this point, it has been providing a stock of methods and general conceptions to serve as tools in psychological study: consciousness and behavior, the introspective and objective methods, reactions and tendencies to reaction, native and acquired, and the part played by the nervous system. Next comes a survey of reactions provided by the native constitution, and after that a study of the process of learning or acquiring reactions. Finally, there are several chapters devoted to such topics as imagination, reasoning and will, which are ways in which the individual utilizes his whole equipment, native and acquired, in meeting the exigencies of life.

EXERCISES

1. Outline the chapter.
2. When does the individual come into existence as an individual? When does he begin to acquire traits? How long does he continue to unfold his native traits, and how long does he continue to acquire traits?
3. Which of the following elements of spoken language are native, and which acquired?
 - (a) Production of voice by the vocal cords and air blast from the lungs.
 - (b) Varying the voice in loudness.
 - (c) Varying the voice in pitch.
 - (d) Production of vowels by different positions of the mouth.
 - (e) Production of consonants by lip and tongue movements.
 - (f) Combination of vowels and consonants into words.
 - (g) Combination of words into idioms and grammatical sentences.
 - (h) Attachment of meanings to words.
 - (i) Sweet-toned voice.
 - (j) Nasal twang.
 - (k) Fluency in speaking.
4. In each of the following reactions, decide whether the connection of stimulus and response is probably native or acquired:

Stimulus	Response
(a) a sudden noise.....	starting
(b) a bright light.....	blinking
(c) a bright light.....	shading your eyes
(d) cold.....	putting on coat
(e) cold.....	shivering
(f) sight of a ball.....	reaching for it
(g) ball in the hand.....	throwing it
(h) slipping.....	righting yourself
(i) row of objects.....	counting them
(j) insulting language.....	anger

REFERENCES

Edward L. Thorndike, in Chapter I of his *Educational Psychology, Briefer Course*, 1914, gives a general survey of the native factors in mental life and behavior.

Hollingworth and Poffenberger, in their *Applied Psychology*, 1917, devote Chapters II and III to the matter of mental heredity.

Norsworthy and Whitley, in their *Psychology of Childhood*, devote Chapters I and II to "original nature".

C. B. Davenport, in his *Heredity and Eugenics*, presents evidence of the importance of heredity in determining mental and moral traits.

Yerkes and Bloomfield, in a short article in the *Psychological Bulletin* for 1910, Vol. 7, pp. 253-263, under the title, "*Do Kittens Instinctively Kill Mice?*", furnish a good illustration of the method employed in distinguishing native from acquired reactions.

CHAPTER VI

INSTINCT

CONDUCT AS DETERMINED BY NATIVE REACTION- TENDENCIES

Instinct is native behavior. It is contrasted with habit, knowledge, or anything in the way of learned reactions. When the mother wasp gathers a store of food suitable for young wasps, lays eggs beside the food and covers the whole with a wall of mud, we know that her behavior is instinctive because she has had no possible chance to learn from older wasps. She has never seen a wasp's nest made, for when the last preceding crop of nests was being made she was herself an unhatched egg. Therefore, she cannot possibly know the use of the nest with its eggs and store of food. She has no "reason" for building the nest, no ulterior purpose, but is impelled to build the nest, simply and solely for the sake of doing just that thing. Thus instinct is contrasted with calculated or reasoned action as well as with learned action. Calculated action is based on knowledge of cause and effect, and this knowledge is acquired by the individual in the course of his experience; but instinct is not based on the individual's experience, but only on his native constitution.

The case of the baby eating is exactly the same as that of the wasp. The baby has not learned to eat, he knows nothing of the use of food and therefore has no ulterior purpose in eating, he does not reason about the matter, but eats simply because hunger is a native impulse to eat.

Eating is an end in itself to a hungry baby, and not a means to some further end; and that is what eating continues to be even to the hungry adult, however much he may learn about the use of food in maintaining life. From a broad philosophical point of view, instinct may be seen to work towards some great end, such as the preservation of the individual or the propagation of the race, but from the individual's own point of view, it is directed simply towards the performance of some particular act, or the accomplishment of some particular result.

If instinct, as a collective term, means native behavior, "an instinct" is a unit of such behavior. Or, it is some unit of native organization that equips the individual to behave in a certain way. Different species of animals have different instincts, i.e., they are differently organized by nature. The differences of organization lie partly in the equipment of sense organs, partly in the equipment of motor organs, and partly in the nerves and nerve centers that, being themselves aroused by way of the sense organs, in turn arouse the motor organs.

The dependence of instinct on sensory equipment becomes clear when we think of animals possessing senses that human beings lack. The instinct of dogs to follow the scent depends on their keen sense of smell. Bees have something akin to a sense of taste in their feet, and follow their own trails by tasting them. Fishes have special sense organs along their sides that are stimulated by water currents, and it is in response to this stimulus that the fish instinctively keeps his head turned upstream.

The dependence of instinct on motor equipment is still more obvious. The flying instinct of birds depends on the possession of wings, and the swimming instinct of the seal depends on the fact that his limbs have the peculiar form of flippers. The firefly instinctively makes flashes of light,

and the electric eel instinctively discharges his electric organ and gives his enemy a shock.

But the core of an instinct is to be sought in the nerve centers, since it is there that the coördination of the muscles is accomplished. A wing or flipper would be of no use unless its muscles were excited to action by the nerve centers, and it would be of very little use unless the nerve centers were so organized as to arouse the muscles in a certain combination, and with a certain force and rhythm. In terms of the nervous system, an instinct is the activity of a team of neurones so organized, and so connected with muscles and sense organs, as to arouse certain motor reactions in response to certain sensory stimuli.

THE DIFFERENCE BETWEEN AN INSTINCT AND A REFLEX

What we have said regarding instinct thus far could equally well be said of reflex action. A reflex is a native reaction, and it is taken care of by a team of neurones in the way just stated. We might speak of a reflex as "instinctive", using this adjective as equivalent to "native"; but we should shrink for some reason from speaking of the pupillary reflex to light as an instinct, or of the "knee jerk instinct", or the "swallowing instinct", or the "flexion instinct". There is some difference between the typical reflex and the typical instinct, though it is not very obvious what the difference is.

The typical reflex is a much simpler act than the typical instinct, but it is impossible to separate the two classes on this basis. At the best, this would be a difference of degree and not of kind. Among reflexes, some are simpler than others, but even the simplest is compound in the sense of being a coördinated movement. The knee jerk is simpler than the flexion reflex, and this is simpler than the scratch

reflex, which consists of a rapid alternation of flexion and extension by one leg, while the other is stiffly extended and supports the trunk. Coughing, which would be called a reflex rather than an instinct, consists of a similar alternation of inspiration and forced expiration, and swallowing consists of a series of tongue, throat and gullet movements. These compound reflexes show that we cannot accept the simple definition that is sometimes given for an instinct, that it is a compound of reflexes. Such a definition would place coughing and swallowing among the instincts, and so do violence to the ordinary use of the word. In point of complexity, we find a graded series ranging from the pupillary reflex at one extreme to the nesting or mating instinct at the other, and no sharp line can be drawn on this score between the reflexes and the instincts.

Another distinction has been attempted on the basis of consciousness. Typically, it may be said, a reflex works automatically and unconsciously, while an instinct is consciously impulsive. The reflex, accordingly, would be an unconscious reaction, the instinct a conscious reaction. But this distinction also breaks down on examination of cases. The pupillary reflex, to be sure, is entirely unconscious. But the flexion reflex is a little different. When unimpeded, it occurs so promptly that we are scarcely aware of the painful stimulus before the reaction has occurred. But let the reaction be hindered—either voluntarily or, for instance, by the foot being seized and held—and a strong conscious impulse is felt to pull the leg away; so that here the flexion reflex would belong among the instincts, according to the proposed distinction.

Similar remarks would apply equally well to coughing, since a strong impulse to cough is felt if the coughing movement is checked. Sneezing, a protective reflex, is usually a slow reaction, giving time for a conscious impulse to

sneeze before the reaction takes place. The same is true of scratching and of swallowing, and of a number of other reflexes. In short, it is impossible to draw a satisfactory line between reflexes and instincts on the basis of conscious impulse.

These cases point the way, however, to what is probably the best distinction. It was when the flexion reflex was *delayed* that it began to look like an instinct, and it was because sneezing was a *slow* response that it had something of the character of an instinct. Typically, a reflex is a prompt reaction. It occurs at once, on the occurrence of its stimulus, and is done with. What is characteristic of the instinct, on the contrary, is the persisting "tendency", set up by a given stimulus, and directed towards a result which cannot be instantly accomplished.

AN INSTINCT IS A NATIVE REACTION-TENDENCY

We would propose, then, to consider an instinct as an inner adjustment, or tendency to reaction. It is this, rather than just a reaction. When a stimulus promptly arouses a reaction, and that ends the matter, we speak of reflex action—provided, of course, the connection between stimulus and response is native. But when a stimulus sets up a tendency to a reaction that cannot be immediately executed, or towards an end-result which cannot immediately be reached, and when the tendency so aroused persists for a time in activity, and gives rise to preparatory reactions, then we speak of instinct.

The "broody" hen makes a good picture of instinct. When in this condition she responds to a nestful of eggs, as she does not at other times, by sitting persistently on them and keeping them covered. She is in a certain "organic state" that facilitates this response. In the absence

of any nestful of eggs, she shows a peculiar restless behavior that indicates to one who knows hens that this one "wants to set." The tendency that has been awakened in her cannot be satisfied by any momentary act, but persists and governs her actions for a considerable period.

The nesting instinct of birds affords a still more complete example. The end-result here, the finished nest, cannot be instantly had, and the pair of birds keep on gathering materials and putting them together until this end-result is present before their eyes. It is not necessary to suppose that the birds have any plan or mental image of what the nest is to be like; probably not. But their state, in the nest-building season, is such that they are impelled to build, and the tendency is not quieted till the completed nest is there.

The mating instinct, in unsophisticated members of the human species, is another perfect example. So is the hunting instinct in a dog; when this instinct is aroused, the animal makes a lot of movements of various sorts, responses to various particular stimuli, but evidently these movements are not sufficient to quiet the tendency, for they continue till the prey is captured. The behavior of a gregarious animal when separated from his fellows shows the same sort of thing. Take a young chick out of the brood and fence it away from the rest. It "peeps" and runs about, attacking the fence at different points; but such reactions evidently do not bring satisfaction, for it varies them until, if a way out of the inclosure has been left, it reaches the other chicks, when this series of acts terminates, and gives way to something quite different, such as pecking for food.

The persisting tendency does not produce the series of movements all by itself, but, as was explained in speaking of tendencies in general, coöperates with sensory stimuli in producing them. Clearly enough, the nest-building bird,

picking up a twig, is reacting to that twig. He does not peck at random, as if driven by a mere blind impulsion to peck. He reacts to twigs, to the crotch in the tree, to the half-built nest. Only, he would not react to these stimuli unless the nesting fit were on him. The nest-building tendency favors response to certain stimuli, and not to others; it facilitates certain reactions and inhibits others. It facilitates reactions that are *preparatory* to the end-result, and inhibits others.

FULLY AND PARTIALLY ORGANIZED INSTINCTS

Insects afford the best examples of very highly organized instincts. Their behavior is extremely regular and predictable, their progress towards the end-result of an instinct remarkably straightforward and sure. They make few mistakes, and do not have to potter around. By contrast, the instincts of mammals are rather loosely organized. Mammals are more plastic, more adaptable, and at the same time less sure; and this is notably true of man. It would be a mistake to suppose that man has few instinctive tendencies; perhaps he has more than any other creature. But his instinctive behavior has not the hard-and-fast, ready-made character that we see in the insects. Man is by all odds the most pottering, hem-and-hawing of animals. Instinct does not lead him straight to his goal, but makes him seek this way and that till he finds it. His powers of observation, memory and thought are drawn into the game, and thus instinct in man is complicated and partly concealed by learning and reasoning.

For example, when an insect needs a nest, it proceeds in orderly fashion to construct a nest of the pattern instinctive to that species of insect; but when a man needs a home, he goes about it in a variable, try-and-try-again

manner, scheming, experimenting, getting suggestions from other people, and finally producing—a dugout, a tree house, a wigwam, a cliff dwelling—something that differs altogether from many other human habitations, except in the fact that it is a habitation and thus satisfies a need which is undoubtedly as instinctive in man as in the insect.

A fully organized instinct is one where the necessary preparatory reactions are linked up closely with the main reaction-tendency, so that, once the main tendency is aroused to activity, the preparatory reactions follow with great sureness. The main team of neurones is closely connected with the subordinate teams that give the preparatory reactions; and these connections do not have to be acquired by experience and training, but are well formed by native growth. Just the right preparatory reactions are linked to the main tendency, so that the whole series of acts is run off with great regularity.

In a loosely organized instinct, the main tendency is not firmly linked with any specific preparatory reactions, but is loosely linked with a great many preparatory reactions, and so gives quite variable behavior, which, however, leads on the whole towards the main goal.

While a creature under the spell of a fully organized instinct is busy, one driven by a loosely organized instinct may be better described as restless. He tries this thing and that, and goes through the kind of behavior that is called "trial and error". A closely knit instinct, then, gives a perfectly definite series of preparatory reactions, while a loosely organized instinct gives trial and error behavior. We shall see later how trial and error furnishes a starting point for learning, and how, in an animal that can learn, those among the trial-and-error reactions that are actually preparatory to the end-result become firmly attached to the main tendency, so that what was by native constitution a loosely or-

ganized instinct may become, through the individual's experience, a closely organized habit. If a man has occasion to build himself many homes, he comes, after a while, to build almost as uniformly and surely as an insect.

INSTINCTS ARE NOT ANCESTRAL HABITS

The theory of inheritance of acquired traits has gone by the board; biologists no longer accept it. Such traits as an individual's tanned skin acquired by living in the tropics, horny hands acquired by hard labor, immunity to measles acquired by having measles, big muscular development acquired by gymnastics, are not transmitted by heredity to the children of the individual who acquired these traits.

Nor are acquired behavior traits transmitted by heredity. Learned reactions are not so transmitted, knowledge is not, acquired skill is not. Learn to cook, to typewrite, or pilot an airplane as perfectly as possible, and your child will still have to learn all over again. You may make your experience valuable to him by *teaching* him, but not in the way of heredity.

Language affords a good test of this matter. A child's parents, and all his ancestors for many generations, may have spoken the same language, but that does not relieve the child of the necessity of *learning* that language. He does not inherit the language habits of his ancestors. He has no native tendency to say "dog", or "chien", or "hund", on sight of this animal. Here in America we have children born of stocks that have spoken foreign languages for many generations; but English becomes their "native tongue" after a generation or two here, that is to say, as soon as the child hears English from infancy.

In short, there is no likelihood whatever that any instinct

ever originated out of a habit or learned reaction. If we could believe it had so originated, that would furnish an easy explanation of the origin of an instinct; but it is contrary to all the known facts.

INSTINCTS NOT NECESSARILY USEFUL IN THE STRUGGLE FOR EXISTENCE

Some of the best-known instincts, such as feeding or mating—or hunting, or flight from danger, or the hibernation of frogs—are so essential for the survival of the individual or the propagation of the next generation that we tend to assume that all instinctive behavior has “survival value”, value, that is, towards the survival of the individual or of the race. But this is an assumption, and it seems not to be borne out by actual observations of instinctive behavior, since, along with the definitely useful reactions, others occur that would seem to have no survival value. Perhaps the crowing of the rooster at dawn would be a case in point; or the elaborate bowing that is observed in some kinds of birds. And there are the less definite, rather random movements of squirming, kicking, running about, wrinkling up the face, etc., that appear in young animals. We may well hesitate before definitely asserting that these movements are of *no* use for survival, but at least their use is not obvious, and there is no reason for assuming that all instinctive behavior must necessarily be useful.

To be sure, the “struggle for existence” would eliminate individuals who behaved in ways that seriously handicapped them in procuring food or escaping from enemies; and therefore we should not expect to find really harmful instincts preserved in the race. But a mode of behavior might be neutral in this respect, or even slightly disadvantageous, and yet not be weeded out unless the struggle for existence were very keen.

The main point is that the psychologist should take instinctive behavior as he finds it, and not allow himself to be prejudiced by the assumption that instinct must necessarily be useful. That has to be shown in each case, not assumed at the outset.

THE SO-CALLED INSTINCTS OF SELF-PRESERVATION AND OF REPRODUCTION

You will hear it stated, by some, that there are just two instincts, and that all instinctive behavior belongs under the head of one or the other of these two. The one is the instinct to preserve one's individual life, and the other is the instinct to propagate the species. Mating, nesting and care of the young come under the reproductive instinct, while feeding, flight from danger, and shunning extreme heat or cold are modes of self-preservation. This seems logical enough, but it is very bad psychology. It amounts to a classification of native reactions from an external point of view, without any consideration of the way the individual is organized. Mice

Perhaps the most obvious objection to these two supposedly all-inclusive instincts is found in what has just been said, to the effect that some instinctive behavior has no known survival value. This amounts to saying that some instincts do not serve either the preservation of the individual or the propagation of the species; and such a statement is probably true, especially of human instincts.

But even if this objection should not hold, there is another, more radical one. Neither of these two big "instincts" is a behavior unit in any sense. Take the "instinct of self-preservation", for example. It would certainly have to include both feeding and escape from danger. But feeding and flight from danger do not belong in a single series

of acts; they are two distinct series, and represent two distinct tendencies. So distinct are they that, as we shall see in the next chapter, they are antagonistic. If the danger-avoiding tendency is aroused, the whole feeding and digestive activity is checked for the time being. The two instincts are antagonistic, in their actual operation; throw one into action, and you throw the other out. It is only from an external point of view that the two can be classed together; in the organization of the individual they are entirely separate.

Not much different is the "instinct of reproduction". In birds, to be sure, there is a fairly continuous series of reactions, that begins with mating, continues with nesting, laying eggs and incubating them, and ends in the care of the young birds. But in mammals there is no such continuous series of reproductive acts, but mating comes to a close and an interval elapses in which there is no behavior going on that has anything to do with reproduction.

Before giving a detailed list of the various human instincts, we shall do well to consider emotion, which is closely bound up with instinct.

EXERCISES

1. Outline the chapter.
2. Explain the differences between these three:
Action governed by instinct.
Action governed by habit.
Action governed by deliberation.
3. What is the objection to each of the following expressions?
 - (a) "The ex-soldier instinctively saluted when he met an officer in the street."
 - (b) "The bee knows by instinct how to construct the honey-comb."
4. Why is it so difficult to find a valid distinction between instinct and reflex action?
5. Why are instincts more universal and uniform than habits?
6. How is instinct an important matter to consider in a study of human motives?
7. Show how the behavior of a hungry child of six or eight years fits the picture of a "loosely organized instinct".

REFERENCES

William James in his *Principles of Psychology*, 1890, has a very stimulating chapter on instinct, in Vol. II, pp. 383-441.

John B. Watson, in Chapters IV and V of his *Behavior*, 1914, gives a good account of the instincts of animals.

CHAPTER VII

EMOTION

VARIOUS ORGANIC STATES, AND THE CONSCIOUS STATES THAT GO WITH THEM

Joy, sorrow, fear, anger, amusement, disgust and curiosity illustrate the meaning of the term "emotion". An emotion is a "moved" or stirred-up state of mind. Or, since almost any such state of mind includes also elements that are cognitive, like recognition of present objects or memories of the past, we might better speak of emotion as the stirred-up-ness present in a state of mind. The emotional part of the total state may be so strong as to overshadow all other components, or it may have less intensity down to zero.

Such is emotion from the introspective point of view; but it can also be observed objectively, and in fact there is more to say about it objectively than introspectively. What appears to introspection as the scarcely analyzable state of anger appears to the external observer as clenched fists, flushed face, labored breathing, tense muscles, loud voice, and many other describable details. Anger is a state of the organism, or state of the individual, rather than simply a state of mind.

We shall have a more comprehensive definition, then, if we substitute "state of the individual" for "state of mind", and say that emotion is a stirred-up state of the individual. It is a conscious state, however; an "unconscious emotion" would be practically a contradiction in terms. Not but that a person may be angry without knowing it. He may be

“unconscious of the fact” that he is angry; which simply means that he is not introspectively observing himself and analyzing his mental state. But it is impossible that his organic state shall be all stirred up and his mental state meanwhile perfectly calm and intellectual. In short, an emotion is a conscious stirred-up state of the organism.

ORGANIC STATES THAT ARE NOT USUALLY CLASSED AS EMOTIONS

Something was said before about “organic states”, under the general head of tendencies to reaction. Fatigue was an example. Now we could include fatigue under the term, “stirred-up state of the organism”; at least, if not precisely “stirred-up”, it is uneasy. It is a deviation from the normal or neutral state. Also, it is often a conscious state, as when we speak of the “tired feeling”; not a purely cognitive state, either—not simply a recognition of the *fact* that we are fatigued—but a state of disinclination to work any longer. Though fatigue is thus so much like an emotion that it fits under our definition, it is not called an emotion, but a sensation or complex of sensations. After hard muscular work, the state of the muscles makes itself felt by “fatigue sensations”, and the sum total of these, coming from many different muscles, makes up the complex sensation of fatigue. After prolonged mental work, there may be fatigue sensations from the eyes and perhaps from the neck, which is often fixed rigidly during strenuous mental activity; and there are perhaps other obscure fatigue sensations originating in other organs and contributing to the total sensation which we know as mental fatigue, or as general fatigue.

Many other organic states are akin to emotion in the same way. The opposite of fatigue, the “warmed-up” condition, brought on by a certain amount of activity after

rest, is a case in point. It is a deviation from the average or neutral condition, in the direction of greater readiness for activity. The warmed-up person *feels* ready for business, full of "ginger" or "pep"—in short, full of life. The name "euphoria", which means about the same as "feeling good", is given to this condition. Drowsiness is another of these emotion-like states; but hunger and thirst are as typical examples as any.

HOW THESE ORGANIC STATES DIFFER FROM REGULAR EMOTIONS

Now why do we hesitate to call hunger, fatigue and the rest by the name of emotions? For two reasons, apparently. There are two salient differences between an organic state such as hunger, and an emotion such as anger.

Hunger we call a sensation because it is *localized*; we feel it in the region of the stomach. Thirst we localize in the throat, muscular fatigue in the fatigued muscles, and there are several other organic states that come to us as sensations from particular organs. This is not entirely true of drowsiness or euphoria, but it is still less true of the emotions, which we feel as in *us*, rather than in any *part* of us. We "feel mad all over", and we feel glad or sorry all over. It is true that, traditionally, the heart is the seat of the emotions, which means, no doubt, that they are felt in the region of the heart more than elsewhere; and other ancient "seats", in the bowels or diaphragm, agree to this extent that they point to the interior of the trunk as the general location where the emotions are felt. But at best the location of emotions is much less definite than that of the sensations of fatigue or hunger.

The second difference between the emotions and the other organic states comes to light when we notice their causes. Thirst, as an organic state, is a lack of water resulting

from perspiration, etc.; hunger as an organic state results from using up the food previously eaten; fatigue results from prolonged muscular activity. Each of these organic states results naturally from some internal bodily process; while, on the contrary, the exciting cause of an emotion is usually something *external*, which has nothing directly to do with the internal state of the body. Here I am, perfectly calm and normal, my organic state neutral, when some one insults me and throws me into a state of rage; this queer state seems to be inside me, specially in the trunk. Now how can the sound of the insulting person's voice produce any change in my insides? Evidently, by way of the auditory nerve, the brain and lower centers, and the motor nerves to the interior. While, then, organic states of the hunger class result directly from internal physiological processes, the organic state in an emotion is aroused by the brain, the brain itself being aroused by some stimulus, usually external.

THE ORGANIC STATE IN ANGER

But perhaps we are going too fast in assuming that there is any peculiar internal state in emotion. Possibly our subjective localization of anger in the trunk is all wrong, and everything there is going on as usual. At least, the question is squarely before us whether or not there is any internal bodily response in emotion.

Suppose we have a tame cat, that knows us well, and, after feeding her a good meal containing some substance that is opaque to the X-rays, suppose we place her on a table and pass X-rays through her body, so as to get a visible shadow of the stomach upon the plate of the X-ray machine. Well and good; the cat is contentedly digesting her meal, and the X-ray picture shows her stomach to be making rhythmical churning movements. In comes a fox

terrier and barks fiercely at the cat, who shows the usual feline signs of anger; but she is held in position and her stomach kept under observation—when, to our surprise, the stomach movements abruptly cease, not to begin again till the dog has been gone for perhaps fifteen minutes. The churning movements of the intestine cease along with those of the stomach, and, as other experiments show, even the gastric juice stops flowing into the stomach. The whole business of digestion halts during the state of anger. So anger is an organic state, without doubt. At least in cats—but the same is found to be true of man, and hence the excellent rule not to get angry on a full stomach.

Stomach-inhibition is not the only internal response during anger. The heart, so long regarded as the seat of the emotions, does beat more forcibly than usual; and the diaphragm, where the old Greeks located the emotions, does make extra-strong breathing movements. There are yet other and more curious changes that have recently been discovered by the physiologists.

GLANDULAR RESPONSES DURING EMOTION

Thus far, we have been considering muscular responses, but now we must turn our attention to the glands. The glands are often affected during emotion, as witness the shedding of tears in grief, sweating in anger, the dry mouth during fear due to inhibition of the salivary glands, and the stoppage of the gastric juice during anger, as just noted. These particular glands all pour out their secretions either upon the skin or upon the mucous membrane of the mouth, stomach, etc.; and such secretion is called “external” in distinction from the “internal secretion” of certain other glands which may be called the glands of internal secretion or the “endocrine glands”. Internal secretions are dis-

charged into the blood vessels, and carried by the blood to all parts of the body, and they have important effects on the activity of various organs.

Of the endocrine glands, we will mention only two, which are known to play an important part in mental life.

The thyroid gland, situated in the lower part of the neck, is necessary for normal brain activity. Without its internal secretion, brain activity is very sluggish.

The adrenals, two little glands located near the kidneys (whence their name, though they have nothing to do with the kidney in function), have a close connection with such emotions as anger. In the normal or neutral state of the organism, the adrenal secretion oozes slowly into the blood, and has a tonic influence on the heart and muscles. But let an anger stimulus occur, and within a few seconds the adrenals are secreting rapidly; all the organs soon get a big dose of the adrenal secretion, and some of them are strongly affected by it. It hastens and strengthens the action of the heart, it causes the large veins inside the trunk to squeeze the blood lagging there back to the heart; and by these two means greatly quickens the circulation. It also affects the liver, causing it to discharge large quantities of stored sugar into the blood. Thus the muscles of the limbs get an unusual quantity of their favorite fuel supplied them, and also, by the increased circulation, an unusual quantity of oxygen; and they are enabled to work with unusual energy. The adrenal secretion also protects them in some way against fatigue.

While the adrenal secretion is thus exerting a very stimulating influence on the limb muscles, it is having just the opposite effect on the digestive organs; in fact it is having the effects described above as occurring there during anger. These inhibitory effects are started by the stomach nerves, but are continued by the action of the adrenal juice

on the stomach walls. The rapid secretion of the adrenal glands during anger is itself aroused by the nerve running to this gland.

THE NERVES CONCERNED IN INTERNAL EMOTIONAL RESPONSE

There is a part of the nervous system called the "autonomic system", so called because the organs it supplies—heart, blood vessels, stomach, intestines and other internal organs, possess a large degree of "autonomy" or independence. The heart, it will be remembered, beats of itself, even when cut off altogether from any influence of the nerve centers; and the same is true in some measure of the other internal organs. Yet they are subject to the influence of the nerve centers, which reinforce and inhibit their activity. Each internal organ has a double supply of nerves, one nerve acting to reinforce the activity of the organ and the other to inhibit it; and both the reinforcing and the inhibiting nerves belong to the autonomic system.

The autonomic is not separate from the main nervous system, but consists of outgoing axons from centers in the cord and "medulla" (part of the brain stem). It has three divisions, one from the medulla, one from the middle reach of the cord, and one from the lower part of the cord; and these three divisions are related to three different emotional states. The upper division, from the medulla, favors digestion by promoting the flow of gastric juice and the churning movements of the stomach; and at the same time it seems to favor the comfortable, rather lazy state that is appropriate for digestion. The middle division (often called the "sympathetic", though the name is rather misleading to a student of psychology, as it has nothing to do with "sympathy") checks digestion, hastens the heart beat, and stimulates the adrenal glands to rapid secretion, thus giving

rise to the organic condition of anger. The lower division has to do with the bladder, rectum and sex organs, and is active during sex excitement, for one thing.

The lower centers in the medulla and cord that give rise to the autonomic nerves are themselves much under the influence of the higher, cerebral centers. Thus appetite for food, and the flow of gastric juice, can be aroused by the sight of good food, or by hearing or reading about food, or even by merely thinking of food; and both anger and sex appetite can be aroused in corresponding ways.

We should notice right here the antagonism that exists between the middle division of the autonomic and the other two. Suppose the upper division is active, as in comfortable digestion, when an angering stimulus supervenes; then, as we have seen, digestion halts, the upper autonomic is shunted out of action by the middle division. In the same way, sex appetite is shunted out by anger.

THE EMOTIONAL STATE AS A PREPARATORY REACTION

An emotion is often spoken of as a disturbance of the normal quiet state, and as if it represented a breakdown of the organism's machinery. Anger or fear is often a nuisance in civilized life, and any strong emotion is apt to disturb mental work or skilled manual work. But if we think ourselves back into a primitive condition of life, when anger means a fight, we see that the organic response in anger makes a first-class preparation for the fight. Rapid circulation, abundant muscular fuel, protection from fatigue—these are all positively useful; and the halting of digestion is useful also in relieving the circulation from taking care of an activity that can afford to wait.

What we have been calling the "organic state in anger" occurs also in *fear* of the strong type (as distinguished from

fear paralysis), and in certain other states that are not exactly either fear or anger, such as the state of a football player before the game, or the state of a student about to take an examination. It is the state of *excitement*, or of being "all keyed up". So far as known, the organic response (including the adrenal secretion) is the same in these various instances of excitement: anger, fear, zeal and so on. When an individual is in this organic state, his muscles will work harder and longer than is otherwise possible; and thus are explained those remarkable cases of extraordinary strength and endurance in great emergencies, as in escaping from a fire or from a bombarded city.

The fear-anger state of the organism, being certainly a state of preparedness for attack or defense, suggests the following generalization: "Any emotion represents internal preparation for some type of overt action." This holds good, at least, for food appetite and sex appetite. Regarding the other emotions, we know too little of the internal responses that may occur, to judge whether or not they have any utility as preparatory reactions.

"EXPRESSIVE MOVEMENTS," ANOTHER SORT OF PREPARATORY REACTIONS

Though we know little of any internal response in many of the emotions, we almost always find some characteristic external movement, such as smiling, scowling, pouting, sneering, sobbing, screaming, shouting or dancing. By aid of such "expressive movements" we are sometimes able to judge the emotional state of another person. But what is the sense of these movements? At first thought, the question itself is senseless, the movements are so much a matter of course, while on second thought they certainly do seem odd. What sense is there is protruding the lips when sulky,

or in drawing up the corners of the mouth and showing the canine teeth in contempt? Perhaps they are just odd tricks of instinct—for we agreed in the preceding chapter not to assume all instinctive responses to be useful. Darwin, however, after studying a great many of these expressive movements, both in men and in animals, reached the conclusion that, if not of present utility, they were survivals of acts that had been useful earlier in the life of the individual or of the race.

Shaking the head from side to side, in negation or unwillingness, dates back to the nursing period of the individual's life, when this movement was made in rejecting undesired food. Directly useful in this case, it was carried over to analogous situations that aroused the child's reluctance.

Showing the teeth in scorn dates back, according to Darwin, to a prehuman stage of development, and is seen in its useful form in animals like the dog or gorilla that have large canine teeth. Baring the teeth in these animals is a preparation for using the teeth; and often, also, it frightens the enemy away and saves the bother of actually attacking "small fry". The movement, Darwin urges, has survived in the race, even after fighting with the teeth has largely disappeared.

Many other expressive movements are traced back in a similar way, though it must be admitted that the racial survivals are usually less convincing than those from the infancy of the individual. The nasal expression in disgust was originally a defensive movement against bad odors; and the set lips of determination went primarily with the set glottis and rigid chest that are useful in lifting heavy weights or in other severe muscular efforts. Such movements, directly useful in certain simple situations, become linked up with analogous situations in the course of the indi-

vidual's experience. Many of them, certainly, we can regard as preparatory reactions.

DO SENSATIONS OF THESE VARIOUS PREPARATORY REACTIONS
CONSTITUTE THE CONSCIOUS STATE OF EMOTION?

No one can doubt that some of the bodily changes that occur during an emotion make themselves felt as sensations. Try this experiment: pretend to be angry—it is not hard!—go through the motions of being angry, and notice what sensations you get. Some from the clenched fist, no doubt; some from the contorted face; some from the neck, which is stiff and quivering. In genuine anger, you could sense also the disturbed breathing, violent heart beat, hot face. The internal responses of the adrenal glands and liver you could not expect to sense directly; but the resulting readiness of the limb muscles for extreme activity is sometimes sensed as a feeling of tremendous muscular power.

Now lump together all these sensations of bodily changes, and ask yourself whether this mass of sensations is not identical with the angry state of mind. Think all these sensations away, and ask yourself whether any angry feeling remains. What else, if anything, can you detect in the conscious emotional state besides these blended sensations produced by internal and external muscular and glandular responses?

If you conclude that the conscious emotion consists wholly of these sensations, then you are an adherent of the famous James-Lange theory of the emotions; if you find any other component present in the emotion, you will find this theory unacceptable.

THE JAMES-LANGE THEORY OF THE EMOTIONS

The American psychologist James, and the Danish psychologist Lange, independently of each other, put forward this theory in the early eighties of the last century, and it has ever since remained a great topic for discussion. According to the theory, the emotion is the *way the body feels while executing the various internal and expressive movements that occur on such occasions*. The "stirred-up state of mind" is the complex sensation of the stirred-up state of the body. Just as fatigue or hunger is a complex of bodily sensations, so is anger, fear or grief, according to the theory.

James says, we do not tremble because we are afraid, but are afraid because we tremble. By that he means that the conscious state of being afraid is composed of the sensations of trembling (along with the sensations of other muscular and glandular responses). He means that the mental state of recognizing the presence of danger is not the stirred-up state of fear, until it has produced the trembling and other similar responses and got back the sensations of them. "Without the bodily states following on the perception"—i.e., perception of the external fact that arouses the whole emotional reaction—"the latter would be purely cognitive in form, pale, colorless, destitute of emotional warmth. We might then see the bear, and judge it best to run, receive the insult, and deem it right to strike, but we should not actually *feel* afraid or angry."

It has proved very difficult to submit this theory to a satisfactory test. The only real test would be to cut off sensations from the interior of the trunk entirely; in which case, if the theory is right, the conscious emotion should fail to appear, or at least lack much of its "emotional warmth". Evidence of this sort has been slow in coming in. One or

two persons have turned up at nerve clinics, complaining that they no longer had any emotions, and were found to have lost internal bodily sensation. These cases strongly support the theory, but others have tended in the opposite direction. The fact that the internal response is the same in anger, and in fear of the energetic type, shows that the difference between these emotions must be sought elsewhere. Possibly sufficient difference could be found in the expressive movements, or in minor internal responses not yet discovered. If not, the theory would certainly seem to have broken down at this point.

In any case, there is no denying the service done by the James-Lange theory in calling attention to bodily sensations as real components of the conscious emotional state.

EMOTION AND IMPULSE

Most people are rather impatient with the James-Lange theory, finding it wholly unsatisfactory, though unable to locate the trouble precisely. They know the theory does not ring true to them, that is all. Now the trouble lies just here: what they mean by "being afraid" is "wanting to get away from the danger", what they mean by "being angry" is "wanting to strike the offending person", and in general what they mean by any of the named "emotions" is not a particular sort of "stirred-up conscious state", but an *impulse* towards a certain action or a certain result. Evidently it would be absurd to say we want to get away from the bear because we tremble, or that until we started to tremble we should be perfectly indifferent whether the bear got us or not.

The tendency to escape is aroused directly by the perception of danger; of that there can be no doubt. It does not depend on trembling, but for that matter neither does it depend on *feeling* afraid. Sometimes we recoil from a sud-

den danger before experiencing any thrill of fear, and are frightened and tremble the next moment, after we have escaped. The stirred-up state develops more slowly than the tendency to escape. The seen danger directly arouses an adjustment towards the end-result of escape, and both the preparatory bodily responses and the feeling of fear develop after this adjustment has been set up. If the end-result is reached instantly, the preparatory reactions and the feeling may not develop at all, or they may put in an appearance after the main act is all over. There is nothing in all this that speaks either for or against the James-Lange theory.

These statements need further elucidation, however. Notice, first, that psychology makes a perfectly proper and important distinction between emotion and impulse. In terms of consciousness, emotion is "feeling somehow", and impulse is "wanting to do something". In behavior terms, emotion is an organic state, and impulse an adjustment of the nerve centers towards a certain reaction. An impulse is a conscious tendency.

Since emotion and impulse so often go together, common sense does not bother to distinguish them, and the common names for the "emotions" are more properly names of impulses. Fear means the impulse to escape, rather than any specific stirred-up state. Psychology has, indeed, made a mistake in taking over these names from common speech and trying to use them as names of specific emotional states. We were having some difficulty, a few moments ago, in finding any great distinction between fear and anger, considered as emotional states—just because we were overlooking the obvious fact that "fear" is an impulse to escape from something, while "anger" is an impulse to get at something and attack it. The adjustments are very different, but the organic states are much alike.

The organic state in fear or anger cannot generate the escape or fighting tendency, since the two tendencies are so different in spite of the likeness of the organic state. The tendencies are aroused directly by the perception of the dangerous or offensive object. The order of events is as follows. The stimulus that sets the whole process going is, let us say, a bear in the woods. First response: seeing the bear. Second response: recognizing the dangerous situation. Third response: adjustment towards escape. Fourth response (unless escape is immediate): internal preparatory

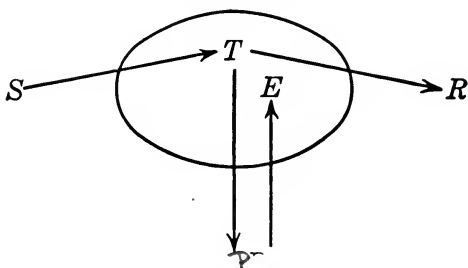

FIG. 24.—Here the stimulus-response diagram is complicated to take account of the emotional state. The ellipse here stands for the brain. *S* arouses *T*, a tendency towards the response *R*. But *T* also arouses *P*, a bodily state of preparedness, and sensations (*E*) of this bodily state, together with *T*, constitute the conscious state of the individual while he is tending towards the response, or end-result, *R*.

reactions, adrenal, etc.; also, probably, external expressive movements and movements steered in the general direction of escape. Fifth response: conscious stirred-up state consisting of blended sensations of all these preparatory reactions. Sixth response (by good luck): definitive escape reaction. Seventh response: satisfaction and quiescence.

EMOTION SOMETIMES GENERATES IMPULSE

Typically, impulse generates emotion. The reaction tendency is primary and the emotion secondary.

But suppose the organic state of fear to be present—

never mind how it got there—might it not act like hunger or fatigue, and generate a fear impulse? Could it not be that a person should first be fearful, without knowing what he was afraid of and without really having anything to be afraid of; and then, as it were, *find* something to be afraid of, something to justify his frightened state? This may be the way in which abnormal fears sometimes arise: a naturally timid individual is thrown by some obscure stimulus into the state of fear, and then attaches this fear to anything that suggests itself, and so comes to be afraid of something that is really not very terrific, such as the number two. "I mustn't do anything twice, that would be dangerous; if I do happen to do it twice, I have to do it once more to avoid the danger; and for fear of inadvertently stopping with twice, it is best always to do everything three times and be safe." That is the report of a naturally timorous young man. We all know the somewhat similar experience of being "nervous" or "jumpy" after escaping from some danger; the organic fear state, once aroused, stays awhile, and predisposes us to make avoiding reactions. In the same way, let a man be "all riled up" by something that has happened at the office, and he is likely to take it out on his wife or children. Slightly irritating performances of the children, that would usually not arouse an angry reaction, do so this evening, because that thing at the office has "made him so cross."

In the same way, let a group of people get into a very mirthful state from hearing a string of good jokes, and a hearty laugh may be aroused by a feeble effort that at other times would have fallen flat.

In such cases, the organic state, once set up in response to a certain stimulus, persists after the reaction to that stimulus is finished and predisposes the individual to make the same sort of reaction to other stimuli.

EMOTION AND INSTINCT

Anger, fear, lust, the comfortable state appropriate to digestion, grief (the state of the weeping child), mirth or amusement, disgust, curiosity, the "tender emotion" (felt most strongly by a mother towards her baby), and probably a few others, are "primary emotions". They occur, that is to say, by virtue of the native constitution, and do not have to be learned or acquired through experience. They are native states of mind; or, as modes of behavior, they are like instincts in being native behavior.

One distinction between emotional and instinctive behavior is that the emotion consists of internal responses, while the instinct is directed outwards or at least involves action on external objects. Another distinction is that the emotional response is something in the nature of a preparatory reaction, while the instinct is directed towards the end-reaction.

The close connection of emotion and instinct is fully as important to notice as the distinction between them. Several of the primary emotions are attached to specific instincts: thus, the emotion of fear goes with the instinct to escape from danger, the emotion of anger goes with the fighting instinct, the emotion of lust with the mating instinct, tender emotion with the maternal instinct, curiosity with the exploring instinct. Where we find emotion, we find also a tendency to action that leads to some end-result.

It has been suggested, accordingly, that each primary emotion is simply the "affective" phase of an instinct, and that every instinct has its own peculiar emotion. This is a very attractive idea, but up to the present it has not been worked out very satisfactorily. Some instincts, such as that for walking, seem to have no specific emotion attached to them. Others, like anger and fear, resemble each other very

closely as organic states, though differing as impulses. The really distinct emotions (not impulses) are much fewer than the instincts.

The most important relationship between instinct and emotion is what we have seen in the cases of anger and a few others, where the emotion represents bodily readiness for the instinctive action.

THE HIGHER EMOTIONS

We have been confining our attention in this chapter to the primary emotions. The probability is that the higher emotions, esthetic, social, religious, are derived from the primary in the course of the individual's experience.

Primary emotions become refined, first by modifications of the motor response, by which socially acceptable reactions are substituted for the primitive crying, screaming, biting and scratching, guffawing, dancing up and down in excitement, etc.; second by new attachments on the side of the stimulus, such that the emotion is no longer called out by the original simple type of situation (it takes a more serious danger, a subtler bit of humor, to arouse the emotional response); and third by combination of one emotion with another. An example of compound emotion is the blend of tenderness and amusement awakened in the friendly adult by the actions of a little child. Hate is perhaps a compound of anger and fear, and pity a compound of grief and tenderness. There are dozens of names of emotions in the language—resentment, reverence, gratitude, disappointment, etc.—which probably stand for compound emotions rather than for primary emotions, but the derivation of each one of them from the primary emotions is a difficult task. The emotional life cannot be kept apart from the life of ideas, for the individual is a good deal of a unit.

EXERCISES

1. Outline the chapter.
2. Make a list of 20 words denoting various emotional states.
3. Trace the expressive facial movement of pouting back to its probable origin in the history of the individual.
4. What internal nerves are concerned with digestion? With fear?
5. Show by diagrams the differences between (a) the common-sense theory of the emotions, (b) the James-Lange theory, (c) the James-Lange theory modified to take full account of the reaction-tendency.
6. Make a list of objections to the James-Lange theory, and scrutinize each objection carefully, to see
 - (a) whether it really attacks the theory, or misconceives it.
 - (b) whether it carries much or little weight.
7. Act out several emotions, (a) by facial expression alone, and (b) by facial expression plus gestures, and let another person guess what emotion you are trying to express. How many times does he guess right under (a), and under (b)?
8. Discuss the relative practical importance of emotion and impulse.

REFERENCES

For the James-Lange theory, see the chapter on the emotions by William James, in his *Principles of Psychology*, 1890, Vol. II, pp. 442-485.

For Darwin's views on expressive movements, see his *Expression of the Emotions in Man and Animals*, first published in 1872.

For pictures of facial expression in various emotions, see Antoinette Feleky, in the *Psychological Review* for 1914, Vol. 21, pp. 33-41.

For the internal physiological changes, see Walter B. Cannon's *Bodily Changes in Pain, Hunger, Fear and Rage*, 1915.

For an interesting and important view of the close connection between emotion and instinct, see William McDougall's *Introduction to Social Psychology*, Chapter II.

CHAPTER VIII

INVENTORY OF HUMAN INSTINCTS AND PRIMARY EMOTIONS

A LIST OF THE NATIVE STOCK OF TENDENCIES AND OF
THE EMOTIONS THAT SOMETIMES GO WITH THEM.

It would be a great mistake to suppose that instinct was important only in animal or child psychology, because the human adult governed his conduct entirely by reason and calculation of consequences. Man does not outgrow instinct, any more than he outgrows emotion. He does not outgrow the native reaction-tendencies. These primitive motives remain in force, modified and combined in various ways, but not eliminated nor even relegated to an unimportant place. Even in his most intelligent actions, the adult is animated by motives that are either plain instincts or else derivatives of the instincts. According to some of the leaders in psychology, he has no other motives than these; according to this book, as will be set forth later, there are "native likes and dislikes" (for color, tone, number, persons, etc.) to be placed beside the instincts as primary motives; but, according to either view, the instincts are extraordinarily important in the study of motivation, and a complete and accurate list of them is very much to be desired. Life is a great masquerade of the instincts, and it is not only entertaining to unmask them, but illuminating as well.

A complete account of an instinct would cover the following points: the stimulus that naturally arouses it, the end-result at which it is aimed, the preparatory reactions that occur, external and internal; and also, from the introspec-

tive side, the conscious impulse, the peculiar emotional state (if any), and the special sort of satisfaction that comes when the end-result is reached. Further, we should know what modifications or disguises the instinct takes on in the course of experience—what new stimuli acquire the power of arousing it, what learned reactions are substituted for the native preparatory and final reactions, and what combinations occur between the instinct in question and other reaction-tendencies.

Besides all this, it would be very desirable to present convincing evidence that each instinct listed is a genuine instinct, a part of the native equipment, and not something built up by experience and training. It is rather absurd, the free and easy way in which an instinct is often assumed, simply to fit behavior which needs to be explained—a money getting instinct, for example, or a teacher-hating instinct. Since money and teachers do not exist in a state of nature, there can be no instincts specifically related to them; and it is incumbent on the psychologist to show how such acquired tendencies are derived from the native tendencies.

The full program outlined above being much too extensive to follow out completely in this chapter, we shall only mention a few salient points under each instinct. We shall try to point out the primitive behavior of the child, that reveals the instinct at its lowest terms, and give some hint also of its importance in adult behavior.

CLASSIFICATION

Of all the instincts, two groups or classes stand out from the rest: the responses to organic needs, and the responses to other persons. The first class includes eating, avoiding injury, and many others; the second class includes the herd instinct, the mating instinct and the parental instinct, these three and perhaps no others.

These two groups out, the rest are rather a miscellaneous collection, including the "random" or playful activity of young children, locomotion, vocalization, laughter, curiosity, rivalry and fighting. They might be named the "non-specific instincts", because the stimulus for each is not easy to specify, being sometimes another person, so that this group has great social importance, but sometimes being impersonal. This third class might also be called the "play instincts", since they are less essential than the other classes for maintaining the individual life or for propagating the species; and are, we may say, less concerned with the struggle for existence than with the joy of living.

Our classification then has three heads:

- (1) Responses to organic needs,
- (2) Responses to other persons,
- (3) Play responses.

RESPONSES TO ORGANIC NEEDS

Something has already been said¹ of the manner in which an organic state, such as lack of water, acting on internal sensory nerves, arouses in the nerve centers an adjustment towards an end-result, and how, if the end-result cannot immediately be attained, preparatory reactions occur, the preparatory reactions being in some cases closely attached, by nature, to the main tendency, and in other cases only loosely attached so that the tendency leads to trial and error behavior. The reactions that are nearest to the end-result are likely to be closely attached to the main tendency, while those that are farther from the end-result are loosely attached. Thus, in the case of *thirst*, the drinking movement itself is about all, in man, that is purely instinctive,

¹ See above, pp. 79-81, 112.

and the way of getting water to the mouth, or the mouth to the water, is a matter for trial and error, and only becomes fixed as the result of a process of learning. Still less can we mention any specific water-seeking reactions, in the human being, that are provided by the native constitution. Yet the whole business of relieving thirst is directed by the native thirst-impulse, and to that extent is an instinctive activity. And shall we say that so simple a matter as meeting this organic need is below the dignity of psychology, and can have little influence on the behavior of mankind? Hardly, when we think of the rôle played by springs, wells and drinking places of all kinds in the life of the race, of aqueducts and reservoirs, of all the beverages that have been invented, and of all the people whose job it has been to provide and dispense them. To be sure, any beverage with a taste, or a "kick", is not simply a thirst-reliever, but makes some additional appeal, good or bad; but all this simply illustrates the way instincts become modified, by combination with other instincts, and by the learning and fixing of various preparatory reactions that were not provided, ready-made, in the native constitution. The drinking instinct, or thirst impulse, is a very good example of this whole class of organic instincts.

Instincts connected with hunger. Here again, the reactions nearest to the end-result (food in the stomach) are provided by nature. Sucking and swallowing appear at birth, chewing with the appearance of the teeth; and the infant also makes what seem to be instinctive movements of seeking the breast, as well as movements of rejecting it when satiated and of spitting out bad-tasting food. Putting food (and other things) into the mouth by the hands seems almost instinctive, and yet it has to be fixed by trial and error. Anything like definite food-seeking behavior, amounting to a *hunting* instinct, scarcely gets a chance to show itself in

the human child, because his food is provided for him. In many animals, hunting is a highly organized instinct; thus, crouching, stalking, springing and teasing the mouse when caught, have been proved to be instinctive in young cats. Some animals have definite food-storing instincts also, and possibly food-storing shows the acquisitive or collecting tendency in its lowest terms. Possibly, that is to say, hunting and collecting, as well as disgust (primarily of bad-tasting or bad-smelling food), are originally parts of the food-getting behavior, having the general character of reactions preparatory to eating. However this may be, we can easily see the great importance of the hunger motive in human life; we have only to consider the matter in the same way as we considered thirst just above.

Breathing and air-getting. Breathing, obviously a native reaction, is ordinarily automatic and needs no preparatory reactions, simply because air is so easy to get. But let breathing be difficult, for any reason, and the stifling sensation is as impulsive as hunger or thirst. The stuffy air in a cave or in a hole under a haymow will lead a child to frantic escape. Possibly the delight in being out of doors which shows itself in young children, and is not lost in adults, represents a sort of air-hunting instinct, parallel to food-hunting. Closely connected with breathing is the function of circulation, automatic for the most part; and we should mention also the organic needs of waste-elimination, which give impulsive sensations akin to hunger and thirst, and lead to more or less organized instinctive reactions.

Responses to heat and cold. The warm-blooded animals, birds and mammals, have the remarkable power of keeping the body temperature constant (at 98-99 degrees Fahrenheit, in man, somewhat higher in birds), in spite of great variations in the external temperature to which the body is exposed, and in spite of great variations in the

amount of heat generated in the body by muscular exercise. Sweating and flushing of the skin are reactions to heat, and prevent the body temperature from rising; paling of the skin, shivering and general muscular activity are responses to cold and prevent the body temperature from falling. Shrinking from great heat or cold are also instinctive, while seeking shelter from the heat or cold is a preparatory reaction that is not definitely organized in the native constitution of man, but gives rise to a great variety of learned reactions, and plays a considerable part in life.

Shrinking from injury. The "flexion reflex" of the arm or leg, which pulls it away from a pinch, prick or burn, is the type of a host of defensive reactions—winking, scratching, rubbing the skin, coughing, sneezing, clearing the throat, wincing, limping, squirming, changing from an uncomfortable position—most or all of them instinctive reactions. With each goes some sort of irritating sensation, as pain, itching, tickling, discomfort; and a conscious impulse to get rid of the irritation is often present. When the simpler avoiding reactions do not remove the irritating stimulus, they are repeated more vigorously or give way to some bigger reaction tending towards the same result. The climax of the avoiding reactions is flight or running away. Akin to flight are cowering, shrinking, dodging or warding off a blow, huddling into the smallest possible space, getting under cover, clinging to another person: and most or all of these, too, are instinctive reactions. With flight and the other larger danger-avoiding reactions there is often present, along with the impulse to escape, the stirred up organic and conscious state of *fear*.

The stimuli that arouse movements of escape are of two sorts: those that directly cause some irritating sensation, and those that are simply signs of danger. The smaller avoiding reactions—flexion reflex, coughing, etc.—are

aroused by stimuli that are directly painful or irritating; whereas flight, cowering, etc., are mostly responses to mere signs of danger. A "sign of danger" is usually seen or heard at some distance, not felt directly on or in the body. Now, while avoiding reactions are attached by nature to the irritating stimuli, it is not at all clear whether escape movements are *natively* attached to any signs of danger, or, if they are, to what particular signs of danger they are attached. What visual or auditory stimuli, that are not directly irritating, will arouse escape movements in a young child? For the youngest children, no such stimuli have been found. You can easily get avoiding reactions from a little baby by producing pain or discomfort; you can get the clinging response by letting the child slip when he is being held in your arms; and you get crying and shrinking on application of a loud, grating noise, such a noise as is irritating in itself without regard to what it may signify. But you cannot get any shrinking from stimuli that are not directly irritating.

For example, you get no sign of fear from a little child on suddenly confronting him with a furry animal. With older children, you do get shrinking from animals, but it is impossible to be sure that the older child has not *learned* to be afraid of them. I have seen a child of two years simply laugh when a large, strange dog came bounding towards him in the park; but a year later he would shrink from a strange dog. Whence the change? There are two possibilities: either a native connection between this stimulus and the shrinking response only reached its maturity when the child was about three years old—and there is nothing improbable in this—or else the child, though actually never bitten by a dog, had been warned against dogs by his elders or had observed his elders shrinking from dogs. Children do pick up fears in this way; for example, children who are natu-

rally not the least bit afraid of thunder and lightning may acquire a fear of them from adults who show fear during a thunderstorm.

On the whole, the danger-avoiding reactions are probably not linked by nature to any special signs of danger. While the emotion of fear, the escape impulse, and many of the escape movements are native, the attachment of these responses to specific stimuli—aside from directly irritating stimuli—is acquired. Fear we do not learn, but we learn what to fear.

Crying. We have the best of evidence that this is a native reaction, since the baby cries from birth on. He cries from hunger, from cold, from discomfort, from pain, and, perhaps most of all, as he gets a little older, from being thwarted in anything he has set out to do. This last stimulus gives the "cry of anger", which baby specialists tell us sounds differently from the cries of pain and of hunger. Still, there is so much in common to the different ways of crying that we may reasonably suppose there is some impulse, and perhaps some emotional state, common to all of them. The common emotion cannot be anger, or hunger, or discomfort or pain. To name it grief or sorrow would fit the crying of adults better than that of little children. The best guess is that the emotional state in crying is the feeling of *helplessness*. The cry of anger is the cry of helpless anger; anger that is not helpless expresses itself in some other way than crying; and the same is true of hunger, pain and discomfort. Crying is the reaction appropriate to a condition where the individual cannot help himself—where he wants something but is powerless to get it. The helpless baby sets up a wail that brings some one to his assistance; that is the utility of crying, though the baby, at first, does not have this result in view, but simply cries because he is hungry and helpless, uncomfortable and

helpless, thwarted and helpless. The child cries less as he grows older, because he learns more and more to help himself.

With the vocal element of crying goes movement of the arms and legs, which also has utility in attracting attention; but what may be the utility of shedding copious tears remains a mystery, in spite of several ingenious hypotheses that have been advanced to explain it.

Fatigue, rest and sleep. That fatigue, primarily an organic state, gives rise to fatigue sensations and to a neural adjustment for rest—a disinclination to work any longer—and that drowsiness is a somewhat different organic state that gives an inclination to sleep—all this has been sufficiently set forth in earlier chapters. Going to sleep is a definite act, an instinctive response to the drowsy state. In the way of preparatory reactions, we find many interesting performances in birds and mammals, such as the curling up of the dog or cat to sleep, the roosting of hens, the standing on one leg of some birds; and we see characteristic positions adopted by human beings, but do not know how far these are instinctive and how far acquired. Closing the eyes is undoubtedly a native preparatory reaction for sleep.

Like the other responses to organic needs, rest and sleep figure pretty largely in the behavior of the adult, as in finding or providing a good place to sleep. Certainly if fatigue and sleep could be eliminated, as some over-enthusiastic workers have pretended to hope, life would be radically changed.

INSTINCTIVE RESPONSES TO OTHER PERSONS

We are next to look for action and emotion aroused by persons, specifically—not by persons and things alike. Fear can be aroused by persons, but also by things. In a social animal, such as man, almost any instinct comes to have

social bearings. Eating and drinking become social matters, and all the organic instincts figure in the placing and making of a home. Home is a place of shelter against heat and cold, it is a refuge from danger, it is where you eat and where you sleep. It meets all these organic needs but—it is specially where “your people” are.

Home is a place where *unlike* persons foregather, male with female, adults with children, and thus it symbolizes the “family instincts”, mating and child-care, which are responses to persons unlike in sex or age. But home also illustrates very well the herd instinct, which is a response to *like* persons, “birds of a feather flocking together”. It is not the single home that illustrates this, but the almost universal grouping of homes into villages or cities.

The herd instinct or gregarious instinct. It might be argued that a city or village was the result of economic causes, or, in the olden days, a means of protection against enemies, and not a direct satisfaction of any instinct in man to flock together. But often a family who know perfectly well that their economic advantage demands their remaining where they are, in some isolated country spot, will pull up stakes and accept an inferior economic status in the city, just because the country is too lonely for them. One woman, typical of a great many, declined to work in a comfortable and beautiful place in the country, because “she didn’t want to see trees and rocks, she wanted to see people”. There is no doubt that man belongs by nature with the deer or wolf rather than with solitary animals such as the lion. He is a gregarious creature.

The gregarious instinct does not by any manner of means account for all of man’s social behavior. It brings men together and so gives a chance for social doings, but these doings are learned, not provided ready-made by the instinct. About all we can lay to the herd instinct is uneasiness when

alone, seeking company, remaining in company, and following the rest as they move from place to place. The feeling of loneliness or lonesomeness goes with being alone, and a feeling of satisfaction goes with being in company.

Probably there is one more fact that belongs under the herd instinct. A child is lonely even in company, unless he is allowed to *participate* in what the others are doing. Sometimes you see an adult who is gregarious but not sociable, who insists on living in the city and wishes to see the people, but has little desire to talk to any one or to take part in any social activities; but he is the exception. As a rule, people wish not only to be together but to do something together. So much as this may be ascribed to the instinct, but no more. "Let's get together and *do something*"—that is as far as the gregarious instinct goes. *What* we shall do depends on other motives, and on learning as well as instinct.

The mating instinct. Attraction towards the opposite sex is felt by a small number of children, by most young people beginning from 15 to 20 years of age, by a minority not till a few years later, and, by a small number, never at all. On account of the late maturing of this instinct, in man, instinctive behavior is here inextricably interwoven with what has been learned. A definite organic and emotional state, lust, goes with this instinct. Preparatory reactions, called "courtship", are very definitely organized in many animals, and often quite elaborate. In man, courtship is elaborate enough, but not definitely organized as an instinct; and yet it follows much the same line as we observe in animal courtship. It begins with admiring attention to one of the opposite sex, followed by efforts to attract that one's attention by "display" (strutting, decoration of the person, demonstrating one's prowess, especially in opposition to rivals). Then the male takes an aggressive attitude, the

female a coy attitude; the male woos, the female hangs back, and something analogous to pursuit and capture takes place, except that the capture may be heartily accepted by both parties.

The "survival value" of this instinct is absolute; without it the race would not long survive. But it has "play value" also, it contributes to the joy of living as well as to the struggle for survival. There is much in social intercourse, and in literature and art, that is motivated by the sex impulse. Some would-be psychologists have been so much impressed by the wide ramifications of the sex motive in human conduct that they have attributed to it all play, all enjoyment, all the softer and lighter side of life, even all the spiritual side of life. One need only run over the long list of instincts, especially those that still remain to be mentioned, in order to be convinced of the one-sidedness of such a view. On the other hand, some moralists have been so deeply impressed by the difficulties that arise out of the sex motive, as to consider it essentially gross and bad; but this is as false as the other view. The sex impulse is like a strong but skittish horse that is capable of doing excellent work but requires a strong hand at the reins and a clear head behind. It is a horse that does not always pull well in a team; yet it is capable of fine teamwork. It can be harnessed up with other tendencies, and when so combined contribute some of its motive force to quite a variety of human activities.

The parental or mothering instinct. In many species of animals, though not by any means in all, one or both of the parents stays by the young till some degree of maturity is reached. In some kinds of fish, it is the male that cares for the young; in birds it is often both parents. In mammals it is always the mother. Instinctively, the mammalian mother feeds, warms and defends her young. Just as in-

instinctively, the human mother does the same. This instinctive reaction to the little baby is attended by a strong emotion, called, for want of a better name, the "tender emotion".

The strongest stimulus to arouse this instinct is the little, helpless baby. The older child has to take second place with the mother, so soon as there is a little baby there. After a child is weaned, and after he is able to get about and do for himself to quite an extent, he has less hold on the maternal instinct. The love and care that he may still get is less a simple matter of instinct.

Though the little baby is the strongest stimulus to this instinct, older children and even adults, provided they are like the baby in being winsome and helpless in some way, may arouse the same sort of feeling and behavior, tender feeling and protective behavior. A pet animal may arouse the same tendency, and a "darling little calf" or a "cute little baby elephant" may awaken something of the same thrill. Even a young plant may be tended with a devotion akin to the maternal. The fact seems to be here, as with other instincts, that objects similar to the natural stimulus may arouse the same impulse and emotion. Love between the sexes is often a compound of sex attraction and the mothering instinct; and it is interesting to watch a happily mated couple each mothering the other.

But is it allowable to speak of this instinct as present in the male human being, or in any one not a mother? Undoubtedly the woman who has recently become a mother is most susceptible to the appeal of a little baby, but the response of other women and of girls to a baby is so spontaneous that we cannot but call it instinctive. Men and boys have no special desire to feed or cuddle a little baby, and are quite contented to leave the care of the baby mostly to the "women folks". But they do object strongly to seeing the

baby hurt or ill-treated, and will respond by protecting it. Also, they like to watch the baby act, and like to help it along in its efforts to do things. This may be instinctive in the man; at least it reminds us of the behavior of a mother cat or dog or horse, when she plays with her young and stimulates them to action. When the mother cat brings a live mouse for her half-grown kittens to practise on, she is acting instinctively, and probably a man is obeying the same instinct when he brings the baby a toy and derives pleasure from watching the baby's attempts to use it.

The parental instinct would thus seem to lie at the root of education, considered as an enterprise of adults directed towards getting the young to acquire the behavior of the race; and it also lies at the root of charity, the desire to protect the helpless.

Is there any instinct in the child answering to the parental, any "filial" instinct, as it were? Psychologists have usually answered no, but possibly they have been misled by the word "filial" and looked in the wrong direction. The parental instinct is an instinct to give, and the answering instinct would be one to take—not to give in return. It is probably not instinctive for the child to do for the parent, but is it not instinctive for the child to take from the parent, and to look to the parent for what he wants? It is not exactly "unnatural conduct" in a child to impose on his mother, as it would be in the mother to impose on the child; but would it not be unnatural in a child to take an unreceptive and distrustful attitude towards his mother?

Filial love is different. It is not purely instinctive, but depends on intelligence. It is only possible if the child has the intelligence to see the parent as something besides a parent—as some one needing care and protection—and if the child himself takes a parental attitude towards the parent. But that is a grown-up attitude, seldom taken by

young children. It is not the infantile instinct, which, if there is such an instinct, is the spring of trustful, docile, dependent, childlike and childish behavior.

THE PLAY INSTINCTS

Any instinct has "play value", but some have also "survival value" and so are serious affairs. Survival value characterizes the instincts we have already listed, both the responses to organic needs and the responses to other people. But there are other instincts with less of survival value, but no less of play value, and these we call the play instincts, without attaching any great importance to the name or even to the classification.

Playful activity. The kicking and throwing the arms about that we see in a well-rested baby is evidently satisfying on its own account. It leads to no result of consequence, except indeed that the exercise is good for the child's muscles and nerves. The movements, taken singly, are not uncoordinated by any means, but they accomplish no definite result, produce no definite change in external objects, and so seem random and aimless to adult eyes. It is impossible to specify the stimulus for any given movement, though probably stimuli from the interior of the body first arouse these responses. They are most apt to occur during the organic state of "euphoria", and tend to disappear during fatigue.

There is a counter-tendency to this tendency towards general activity, and that is *inertia*, the tendency towards inactivity or *economy of effort*. Most pronounced in fatigue, this also appears in lassitude and inert states that cannot be called fatigue because not brought on by excessive activity. After sleep, many people are inert, and require a certain amount of activity to "warm up" to the active condition. As the child grows older, the "economy of ef-

fort" motive becomes stronger, and the random activity motive weaker, so that the adult is less playful and less responsive to slight stimuli. He has to have some definite goal to get up his energy, whereas the child is active by preference and just for the sake of activity.

During the first year or so of the child's life, his playful activity takes shape in several ways. First, out of the great variety of the random movements certain ones are picked out and fixed. This is the way with putting the hand into the mouth or drumming on the floor with the heels, and these instances illustrate the important fact that many learned acts develop out of the child's random activity. Without play activity there would be little work or accomplishment of the distinctively human type. Second, certain specific movements, those of locomotion and vocalization, appear with the ripening of the child's native equipment, and take an important place in his play. Third, his play comes to consist more and more of responses to external objects, instead of to internal stimuli as at first. The playful responses to external objects fall into two classes, according as they manipulate objects or simply examine them.

We have, then, a small group of instincts that is very closely related to the fundamental instinct of random activity.

Locomotion. Evidence has already been presented² indicating that walking is instinctive and not learned, so that the human species is no exception to the rule that every species has its instinctive mode of locomotion. Simpler performances which enter into the very complex movement of walking make their appearance separately in the infant before being combined into walking proper. Holding up the head, sitting up, kicking with an alternate motion of the

¹ See p. 95.

two legs, and creeping, ordinarily precede walking and lead up to it.

What is the natural stimulus to locomotion? It is as difficult to say as it is to specify the stimulus in other forms of playful activity. From the fact that blind children are usually delayed in beginning to walk, we judge that the sense of sight furnishes some of the most effective stimuli to this response. Often the impulse attending locomotion is the impulse to approach some seen object, but probably some satisfaction is derived simply from the free movement itself. There certainly is no special emotion going with locomotion. Locomotion has, of course, plenty of "survival value", and might have been included among the organic instincts.

Some of the other varieties of human locomotion, such as running and jumping, are probably native. Others, like hopping and skipping, are probably learned. As to climbing, there is some evolutionary reason for suspecting that an instinctive tendency in this direction might persist in the human species, and certainly children show a great propensity for it; while the acrobatic ability displayed by those adults whose business leads them to continue climbing is so great as to raise the question whether the ordinary citizen is right when he thinks of man as essentially a land-living or surface-living animal. As to swimming, the theory is sometimes advanced that this too is a natural form of locomotion for man, and that, consequently, any one thrown into deep water will swim by instinct. Experiments of this sort result badly, the victim clutching frantically at any support, and sometimes dragging down with him the theorist who is administering this drastic sort of education. In short, the instinctive response of a man to being in deep water is the same as in other cases of sudden withdrawal of solid support; it consists in clinging and is attended by the emotion of fear.

Vocalization. Crying at birth proves voice-production to be a native response, but we are more interested just here in the playful cooing and babbling that appear when the child is a few weeks or months old. This cheerful vocalization is also instinctive, in all probability, since the baby makes it before he shows any signs of responding imitatively to the voices of other people. It seems to be one form of the random activity that goes with euphoria. The child derives satisfaction not so much from the muscular activity of vocalization as from the sounds that he produces, so that deaf children, who begin to babble much like other children, lag behind them as the months go by, from not deriving this auditory satisfaction from the vocal activity. Though whistling, blowing a horn, shaking a rattle and beating a drum are not native responses, it is clear that the child naturally enjoys producing sounds of various sorts.

The baby's cheerful babbling is the instinctive basis on which his speech later develops through a process of learning.

Manipulation. While the first random activity of the baby has nothing to do with external objects, but simply consists of free movements of the arms and legs, after a time these give place to manipulation of objects. The baby turns things about, pulls and pushes them, drops them, throws them, pounds with them. Thus he acquires skill in handling things and also learns how things behave. This form of playful activity contains the germ of constructiveness and of inventiveness, and will come into view again under the head of "imagination."

Exploration or curiosity. Along with manipulation goes the examination of objects by the hand, the mouth, the eyes and ears, and all the senses. Listening to a sudden noise is one of the first exploratory reactions. Following a moving light with the eyes, fixing the eyes upon a

little Stanley

bright object, and exploring an object visually by looking successively at different parts of it, appear in the first few months of the baby's life. Exploration by the hands and by the mouth appear early. Sniffing an odor is a similar exploratory response. When the child is able to walk, his walking is dominated largely by the exploring tendency; he approaches what arouses his curiosity, and embarks on little expeditions of exploration. Similar behavior is seen in animals and is without doubt instinctive. With the acquisition of language, the child's exploration largely takes the form of asking questions.

The stimulus that arouses this sort of behavior is something new and unfamiliar, or at least relatively so. When an object has been thoroughly examined, it is dropped for something else. It is when the cat has just been brought into a strange house that she rummages all over it from garret to cellar. A familiar object is "taken for granted", and arouses little exploratory response.

Quite a group of conscious impulses and emotions goes with exploratory behavior. The feeling or impulse of curiosity is something that everybody knows; like other impulses, it is most strongly felt when the end in view cannot be immediately reached. When you are prevented by considerations of propriety or politeness from satisfying your curiosity, then it is that curiosity is most "gnawing". A very definite emotion that occurs on encountering something extremely novel and strange is what we know as "surprise", and somewhat akin to this is "wonder".

Exploration, though fundamentally a form of playful activity, has great practical value in making the child acquainted with the world. It contains the germ of seeking for knowledge. We shall have to recur to this instinct more than once, under the head of "attention" and again under "reasoning".

Manipulation and exploration go hand in hand and might be considered as one tendency rather than two. The child wishes to get hold of an object that arouses his curiosity, and he examines it while handling it. You cannot properly get acquainted with an object by simply looking at it, you need to manipulate it and make it perform; and you get little satisfaction from manipulating an object unless you can watch how it behaves.

Tendencies running counter to exploration and manipulation. Just as playful activity in general is limited by the counter tendencies of fatigue and inertia, so the tendency to explore and handle the unfamiliar is held in check by counter tendencies which we may call "caution" and "contentment".

Watch an animal in the presence of a strange object. He looks at it, sniffs, and approaches it in a hesitating manner; suddenly he runs away for a short distance, then faces about and approaches again. You can see that he is almost evenly balanced between two contrary tendencies, one of which is curiosity, while the other is much like fear. It is not full-fledged fear, not so much a tendency to escape as an alertness to be ready to escape.

Watch a child just introduced to a strange person or an odd-looking toy. The child seems fascinated, and can scarcely take his eyes from the novel object, but at the same time he "feels strange", and cannot commit himself heartily to getting acquainted. There is quite a dose of caution in the child's make-up—more in some children than in others, to be sure—with the result that the child's curiosity gets him into much less trouble than might be expected. Whether caution is simply to be identified with fear or is a somewhat different native tendency, it is certainly a check upon curiosity.

By "contentment" we mean here a liking for the familiar,

which offsets to some extent the fascination of the novel. If you are perfectly contented, you are not inclined to go out exploring; and when you have had your fill of the new and strange, you like to get back to familiar surroundings, where you can rest in content. Just as playful behavior of all sorts decreases with increasing age, so the love for exploring decreases, and the elderly person clings to the familiar. But even children may insist in occupying their own particular chair, on eating from a particular plate, and on being sung to sleep always with the same old song. They are "little creatures of habit", not only in the sense that they readily form habits, but in the sense that they find satisfaction in familiar ways and things. Here we see the germ of a "conservative" tendency in human nature, which balances, to a greater or less extent, and may decidedly over-balance, the "radical" tendency of exploration.

Laughter. We certainly must not omit this from our list of instincts, for, though it does not appear till some time after birth, it has all the earmarks of an instinctive response. If it were a learned movement, it could be made at will, whereas, as a matter of fact, few people are able to produce a convincing laugh except when genuinely amused, which means when the instinctive tendency to laugh is aroused by some appropriate stimulus. The emotion that goes with laughing may be called mirth or amusement, and it is a strongly impulsive state of mind, the impulse being simply to laugh, with no further end in view.

The most difficult question about laughter is to tell in general psychological terms what is the stimulus that arouses it. We have several ingenious theories of humor, which purport to tell; but they are based on adult humor, and we have as yet no comprehensive genetic study of laughter, tracing it up from its beginnings in the child. Laughing certainly belongs with the play instincts, and possibly the

stimulus is no more definite, at first, than that which arouses other playful activity. The baby seems to smile, at first, just from good spirits (euphoria). The stimuli that, a little later, arouse a burst of laughter have an element of what we may call "expected surprise" (as dropping a rattle and exploding with laughter when it bangs on the floor, and keeping this up time after time), and this element can still be detected in various forms of joke that are effective mirth-provokers in the adult. But why the child should laugh when tickled, at the same time trying to escape, is a poser. Many students of humor have subscribed to the theory that what makes us laugh is a sudden sense of our own superiority, thus attaching laughter to the self-assertive instinct, soon to be discussed. The laugh of victory, the laugh of defiance, the laugh of mockery, the sly or malicious laugh, support this theory, but can it be stretched to cover the laugh of good humor, the tickle laugh, or the baby's laugh in general? That seems very doubtful, and we must admit that we do not know the essential element in a laughter stimulus. One thing is fairly certain: that, while laughing is a native response, we learn what to laugh at, for the most part, just as we learn what to fear.

Fighting. Hold the new-born infant's arms tightly against its sides, and you witness a very peculiar reaction: the body stiffens, the breath may be held till the face is "red with anger"; the child begins to cry and then to scream; the legs are moved up and down, and the arms, if they can be got free, make striking or slashing movements. In somewhat older children, any sort of restraint or interference with free movement may give a similar picture, except that the motor response is more efficient, consisting in struggling, striking, kicking, and biting. It is not so much pain as interference that gives this reaction. You get it if you take away a toy the child is playing with, or if you forbid

the child to do something he is bent on doing. In animals, the fighting response is made to restraint, to being attacked, or to being interfered with in the course of feeding, or mating, or in the instinctive care of the young. The mother lioness, or dog or cat or hen, is proverbially dangerous; any interference with the young leads to an attack by the mother. The human mother is no exception to this rule. In human adults, the tendency to fight is awakened by any interference with one's enterprises, by being insulted or got the better of or in any way set down in one's self-esteem.

In general, the stimulus to fighting is restraint or interference. Let any reaction-tendency be first aroused and then interfered with, and pugnacious behavior is the instinctive result.

The stimulus may be an inanimate object. You may see a child kick the door viciously when unable to open it; and grown-ups will sometimes tear, break or throw down angrily any article which they cannot make do as they wish. A bad workman quarrels with his tools. Undoubtedly, however, interference from other persons is the most effective stimulus.

The impulse so aroused is directed primarily towards getting rid of the restraint or interference, but also towards inflicting damage on the opponent; and with this impulse often goes the stirred-up organic and emotional state of anger. As brought out in the chapter on emotion, the organic state in anger is nearly or quite identical with that in fear of the active type; and the two states of the individual differ in respect to impulse rather than in respect to emotion. In fear, the impulse is to get away from the adversary, in anger to get at him. The emotion of anger is not always aroused in fighting, for sometimes there is a cold-blooded desire to damage the adversary.

The motor response, instinctively consisting of struggling, kicking, etc., as already described, becomes modified

by learning, and may take the form of scientific fistwork, or the form of angry talk, favored by adults. Or, the adversary may be damaged in his business, in his possessions, in his reputation, or in other indirect ways. The fighting spirit, the most stimulating of the emotions, gives energy to many human enterprises, good as well as bad. The successful reformer must needs be something of a fighter.

Thus far we have said nothing to justify our placing fighting here among the play instincts. Fighting against attack has survival value, fighting to protect the young has survival value, and, in general, the defensive sort of fighting has survival value, even though interference with play activity is just as apt to give this response as interference with more serious activities.

But there is more than this to the fighting instinct. The stimulus of interference is not always required. Consider dogs. The mere presence of another dog is often enough to start a scrap, and a good fighting dog will sally forth in search of a fight, and return considerably mauled up, which does not improve his chances for survival, to say the least. Fighting of this aggressive sort is a luxury rather than a necessity. It has play value rather than survival value. There can be no manner of doubt that pugnacious individuals, dogs or men, get more solid satisfaction from a good fight than from any other amusement. You see people "itching for a fight", and actually "trying to pick a quarrel", by provoking some other person who is strictly minding his own business and not interfering in the least. A battle of words usually starts in some such way, with no real reason, and a battle of words often develops into a battle of tooth and nail. Two women were brought before the judge for fighting, and the judge asked Mrs. Smith to tell how it started. "Well, it was this way, your honor. I met Mrs. Brown carrying a basket on her arm, and I says

to her, 'What have ye got in that basket?' says I. 'Eggs', says she. 'No!' says I. 'Yes!' says she. 'Ye lie!' says I. 'Ye lie!' says she. And a 'Whoop!' says I, and a 'Whoop!' says she; and that's the way it began, sir."

We have, then, to recognize aggressive fighting, in addition to defensive, and the aggressive sort certainly belongs among the play instincts.

The instincts that by acting counter to fighting hold it in check are several: laughter—a good laugh together allays hostility; or the parental instinct—a parent will stand treatment from his child that he would quickly resent from any one else; or self-assertion—"Too proud to fight!" But the most direct checks are afforded by inertia—"What's the use?"—and especially by fear and caution.

Fighting, both defensive and aggressive, has so close a connection with the more generalized self-assertive tendency that it might be included under that instinct. It may be regarded as a special form of self-assertive behavior, often complicated with the emotion of anger.

Self-assertion. What then is this wonderful instinct of self-assertion, to which fighting and much of laughing are subordinate? "Assertiveness", "masterfulness", and the "mastery impulse" are alternative names. Of all the native tendencies, this is the one most frequently aroused, since there is scarcely a moment of waking (or dreaming) life when it is not more or less in action. It is so much a matter of course that we do not notice it in ourselves, and often not in other persons; and even clever psychological observers have seemed entirely blind to it, and given it no place in their list of instincts.

Self-assertion, like fighting, has two forms, the defensive and the aggressive, and in either case it may be a response to either people or things. That gives four varieties of self-assertive behavior, which may be labeled as follows:

1. Defensive reaction to things, overcoming obstruction, putting through what has been undertaken—the success motive.

2. Defensive reaction to persons, resisting domination by them—the independence motive.

3. Aggressive reaction to things—seeking for power.

4. Aggressive reaction to persons—seeking to dominate.

We will take these up in order, beginning with the most elemental.

1. Overcoming obstruction. The stimulus here is much the same as that which induces fighting, but the response is simpler, without anger and without the impulse to do damage. Take hold of a baby's foot and move it this way or that, and you will find that the muscles of the leg are offering resistance to this extraneous movement. Obstruct a movement that the baby is making, and additional force is put into the movement to overcome the obstruction. An adult behaves in a similar way. Let him be pushing a lawnmower and encounter unexpected resistance from a stretch of tough grass; involuntarily he pushes harder and keeps on going—unless the obstruction is too great. Let him start to lift something that is heavier than he thinks; involuntarily he “strains” at the weight, which means that a complex instinctive response occurs, involving a rigid setting of the chest with holding of the breath, and increased muscular effort. This instinctive reaction may be powerful enough to cause rupture.

Other than purely physical resistance is overcome by other self-assertive responses. When the child's toy will not do what he wants it to do, he does not give up at once, but tries again and puts more effort into his manipulation. When, in school, he is learning to write, and finds difficulty in producing the desired marks, he bends over the desk, twists his foot round the leg of his chair, screws up his face,

and in other ways reveals the great effort he is making. An adult, engaged in some piece of mental work, and encountering a distraction, such as the sound of the phonograph downstairs, may, of course, give up and listen to the music, but, if he is very intent on what he is doing, he puts more energy into his work and overcomes the distraction. When he encounters a baffling problem of any sort, he does not like to give it up, even if it is as unimportant as a conundrum, but cudgels his brains for the solution. As a general proposition, and one of the most general propositions that psychology has to present, we may say that obstruction of any sort, encountered in carrying out any intention whatever, acts as a stimulus to the putting of additional energy into the action.

Anger is often aroused by obstruction, but anger does not develop a tenth as often, in the course of the day, as the plain overcoming reaction. The impulse is not to do damage, but to overcome the obstruction and do what we have set out to do. The emotional state might sometimes be called "determination", sometimes "zeal"; but the most elementary state belonging here is *effort*. The feeling of effort is, partly at least, a sensation complex resulting from stiffening the trunk and neck, knitting the brows, and other muscular strains that have practical utility in overcoming physical resistance and that are carried over to the overcoming of other sorts of resistance, where they have no obvious utility. Effort is a simpler emotion than anger, and occurs much more frequently.

2. Resisting domination by other persons. The child shows from an early age that he "has a will of his own", and "wants his own way" in opposition to the commands of other persons. There is an independent spirit in man that is native rather than acquired. The strength of this impulse differs, to be sure, in different individuals, some chil-

dren being more "contrary" and others more docile; but there probably never was a child without a good dose of disobedience in his make-up. In order to have a nice, obedient child, you have to "break" him like a colt, though you can use reason as well as force in breaking a child. This process of "breaking" gives a habit of obedience to certain persons and along certain lines; but, outside of these limits, the child's independence is still there and ready to be awakened by any attempt to dominate him. In youth, with the sense of power that comes from attaining adult stature and muscular strength, the independent spirit is strengthened, with the result that you seldom see a youth, or an adult, who can take orders without at least some inner opposition and resentment.

3. Seeking for power over things. The self-assertive response to things is not limited to overcoming the obstructions offered by things to the accomplishment of our purposes; but we derive so much positive satisfaction from overcoming obstruction and mastering things that we go out in search of things to master. The child's manipulation has an element of masterfulness in it, for he not only likes to see things perform, but he likes to be the one that makes them perform. If he has a horn, he is not satisfied till he can sound it himself. The man with his automobile is in the same case. When it balks, he is stimulated to overcome it; but when it runs smoothly for him, he has a sense of mastery and power that is highly gratifying. Chopping down a big tree, or moving a big rock with a crowbar, affords the same kind of gratification; and so does cutting with a sharp knife, or shooting with a good bow or gun, or operating any tool or machine that increases one's power. Quite apart from the utility of the result accomplished, any big achievement is a source of satisfaction to the one who has done it, because it gives play to aggressive self-assertion. Many

great achievements are motivated as much by the zest for achievement as by calculation of the advantages to be secured.

4. Seeking to dominate other people. The individual not simply resists domination by other people, but he seeks to dominate them himself. Even the baby gives orders and demands obedience. Get a number of children together, and you will see more than one of them attempt to be the leader in their play. Some must necessarily be followers just now, but they will attempt to take the lead on another occasion. The "born leader" is perhaps one who has an exceptionally strong dose of masterfulness in his make-up, but he is, still more, one who has abilities, physical or mental, that give him the advantage in the universal struggle for leadership.

Besides giving orders and taking the lead, there are other ways in which the child finds satisfaction for his instinct to dominate. Showing off is one, bragging is one, doing all the talking is one; and, though in growing older and mixing with people the child becomes less naïve in his manner of bragging and showing off, he continues even as an adult to reach the same end in more subtle ways. Going about to win applause or social recognition is a seeking for domination. Anything in which one can surpass another becomes a means of self-assertion. One may demonstrate his superiority in size, strength, beauty, skill, cleverness, virtue, good humor, coöperativeness, or even humility, and derive satisfaction from any such demonstration. The impulse to dominate assumes literally a thousand disguises, more rather than less.

Rivalry and *emulation*, sometimes accorded a separate place in a list of the instincts, seem well enough provided for under the general head of self-assertion. They belong on the social side of assertive behavior, i.e., they are responses to other people and aim at the domination of other

people or against being dominated by them. But the struggle for mastery, in rivalry, does not take the form of a direct personal encounter. Compare wrestling with a contest in throwing the hammer. In wrestling the mastery impulse finds a direct outlet in subduing the opponent, while in throwing the hammer each contestant tries to beat the other indirectly, by surpassing him in a certain performance. This you would call rivalry, but wrestling is scarcely rivalry, because the struggle for mastery is so direct. Rivalry may seek to demonstrate superiority in some performance, or to win the favor of some person or social group, as in the case of rivals in love.

When we speak of "emulation", we have in mind the sort of behavior observed when one child says, "See what I can do!" and the other counters with, "Pooh! I can do that, too". Or, the first child wins applause by some performance, and we then notice the second child attempting the same. It is a case of resisting the indirect domination of another, by not letting him surpass us in performance or in social recognition.

Thwarted self-assertion deserves special mention, as the basis for quite a number of queer emotional states. Shame, sulkiness, sullenness, peevishness, stubbornness, defiance, all go with wounded self-assertion under different conditions. Envy and jealousy belong here, too. Shyness and embarrassment go with self-assertion that is doubtful of winning recognition. Opposed to all these are self-confidence, the cheerful state of mind of one who seeks to master some person or thing and fully expects to do so, and elation, the joyful state of one who has mastered.

Submission. Is there any counter-tendency that limits self-assertion and holds it in check? Inertia and fear of course have this effect, but is there any specific instinct precisely opposite to self-assertion? A difficult question, not

yet to be answered with any assurance; but there is some evidence of a native submissive or yielding tendency. Two forms may be distinguished: yielding to obstruction, and yielding to the domination of other persons.

Giving up, in the face of obstacles, is certainly common enough, but at first thought we should say that the individual was passive in the matter, and simply forced to yield, as a stone is brought to a stop when it strikes a wall. In reality, giving up is not quite so passive as this. There is no external force that can absolutely force us to give up, unless by clubbing us on the head or somehow putting our reactive mechanism out of commission. As long as our brain, nerves and muscles are able to act, no external force can absolutely compel us to cease struggling. Since, then, we do cease struggling before we are absolutely out of commission, our giving up is not a purely passive affair, but our own act, a kind of reaction; and no doubt a native reaction. Further, when struggling against a stubborn obstacle, we sometimes feel an *impulse to give up*, and giving up brings relief.

The ability to give up is not a mere element of weakness in our nature, but is a valuable asset in adapting ourselves to the environment. Adaptation is called for when the reaction first and most naturally made to a given situation does not meet the requirements of the situation. A too stubborn assertiveness means persistence in this unsuitable reaction, and no progress towards a successful issue; whereas giving up the first plan of attack, and trying something else instead, is the way towards success. Some people are too stubborn to be adaptable.

The docility of the child, who believes whatever is told him, has in it an element of submissiveness. There is submissiveness also in the receptive attitude appropriate in observation and forming opinions—the attitude of looking for the facts and accepting them as they are rather than seeking

to confirm one's own prepossessions. Bias is self-assertive, impartiality is submissive to some degree.

Yielding to the domination of other persons often occurs unwillingly, and then comes under the head of "thwarted self-assertion"; but the question is whether it ever occurs willingly and affords satisfaction to the individual who yields. We certainly yield with good grace to one who so far outclasses us that competition with him is unthinkable. An adult may arouse the submissive response in a child; and the social group, by virtue of its superior power and permanence, may arouse it in the individual adult. Hero worship seems a good example of willing submission, agreeable to the one who submits. There are persons who are "lost" without a hero, without some one to lean on, some one to tell them what to do and even what to believe. This looks much like the "filial" or "infantile" instinct that was mentioned before as a possibility, and the dependent spirit in an adult possibly represents a continuation of the infantile attitude into adult life.

Some behavior that looks submissive is really self-assertion in disguise. There are two forms of self-assertion that are specially likely to be taken for submission. Wounded or thwarted self-assertion is one. Shame and envy are like submission in this respect, that they involve an absence of self-confidence or self-assurance, but they do not afford the satisfaction of willing submission, nor the relief of giving up the struggle against obstacles. So far from being genuinely submissive, they are states in which the self is making a violent and insistent demand for justification or social recognition. The other form of self-assertion which looks like submission occurs when a person identifies himself with a superior individual or with a social group. He will then boast of the prowess of his hero or of the prestige of his group, whether it be his family, his school,

his town or his country. Now, boasting cannot by any stretch of the imagination be regarded as a sign of submissiveness; it is a sign of assertiveness, and nothing else. What has happened here is that the individual, having identified himself with his hero or his group, finds in their greatness a means of asserting himself as against other individuals who have not the good fortune to be so identified. This transferred self-assertion is a strong element in loyalty and public spirit, and plays a large and useful part in public affairs.

EXERCISES

1. Make an outline of the chapter, in the form of a table, which shall show for each instinct: (a) the natural stimulus, (b) the native motor response, (c) the end-result that the instinct tends towards, in its adult as well as its native condition, and (d) the emotion, if any, that goes with the activity of the instinct.

2. An adult tendency or propensity may be simply an unmodified instinct, or it may be derived from instincts by combination, etc. Try to identify each of the following as an instinct, or to analyze it into two or more instincts:

(a) Love for adventure.

(b) Patriotism.

(c) A father's pride in his children.

(d) Love for travel.

(e) Insubordination.

(f) Love for dancing.

3. Which of the instincts are most concerned in making people work?

4. Show how self-assertion finds gratification in the life-work of an actor.

a physician.

a housekeeper.

a teacher.

a railroad engineer.

5. Arrange the following impulses and emotions in the order of the frequency of their occurrence in your ordinary day's work and play:

(a) Fear.

(b) Anger.

(c) Disgust.

(d) Curiosity.

(e) Self-assertion.

(f) Submission.

(g) The tendency to protect or "mother" another.

6. How do "practical jokes" lend support to the view that laughter is primarily aroused by a sense of one's own superiority?

7. Get together a dozen jokes or funny stories, and see how many of them can be placed with the practical jokes in this respect.

8. Mention some laughter-stimuli that do not lend support to the theory mentioned in Exercise 6.

9. What instincts find outlet in (a) dress, (b) automobiling, (c) athletics, (d) social conversation?

REFERENCES

McDougall's *Social Psychology* gives, in Chapters III and IV, an inventory of the instinctive equipment of mankind, and in Chapter V attempts to analyze many complex human emotions and propensities into their native elements.

Thorndike, in his *Educational Psychology, Briefer Course, 1914*, Chapters, II-V, attempts a more precise analysis of stimulus and response.

Watson's *Psychology from the Standpoint of a Behaviorist, 1919*, attempts in Chapter VI to show that there are only three primary emotions, fear, rage and love; and in Chapter VII gives a critical review of the work on human instincts.

H. C. Warren, in Chapter VI of his *Human Psychology, 1919*, gives a brief survey of the reflexes and instincts.

CHAPTER IX

THE FEELINGS

PLEASANTNESS AND UNPLEASANTNESS, AND OTHER STATES OF FEELING, AND THEIR INFLUENCE UPON BEHAVIOR

Feeling is subjective and unanalyzed. It is conscious, and an "unconscious feeling" would be a contradiction in terms. But, while conscious, it is not cognitive; it is not "knowing something", even about your subjective condition; it is simply "the way you feel". As soon as you begin to analyze it, and say, "I feel badly here or there, in this way or in that", you *know* something about your subjective condition, but the feeling has evaporated for the instant. In passing over into definite knowledge of facts, it has ceased to be feeling.

Feeling is an undercurrent of consciousness, or we might call it a background. The foreground consists of what you are taking notice of or thinking about, or of what you are intending to do; that is to say, the foreground is cognitive or impulsive, or it may be both at once, as when we are intent on throwing this stone and hitting that tree. In the background lies the conscious subjective condition. Behind facts observed and acts intended lies the state of the individual's feeling, sometimes calm, sometimes excited, sometimes expectant, sometimes gloomy, sometimes buoyant.

The number of different ways of feeling must be very great, and it would be no great task to find a hundred different words, some of them no doubt partly synonymous, to complete the sentence, "I feel ———". All the emo-

tions, as "stirred-up states of mind", belong under the general head of the feelings.

But when the psychologist speaks of *the feelings*, he usually means the *elementary* feelings. An emotion is far from elementary. If you accept the James-Lange theory, you think of an emotion as a blend of organic sensations; and if you reject that theory, you would still probably agree that such an emotion as anger or fear seems a big, complex state of feeling. ✕ It seems more complex than such a sensation as red, warm, or bitter, which are called elementary sensations because no one has ever succeeded in decomposing them into simpler sensations. Now, the question is whether any feelings can be indicated that are as elementary as these simple sensations.

PLEASANTNESS AND UNPLEASANTNESS ARE SIMPLE FEELINGS

No one has ever been able to break up the feelings of pleasantness and unpleasantness into anything simpler. "Pleasure" and "displeasure" are not always so simple; they are names for whole states of mind which may be very complex, including sensations and thoughts in addition to the feelings of pleasantness and unpleasantness. "Pain" does not make a satisfactory substitute for the long word "unpleasantness", because "pain", as we shall see in the next chapter, is properly the name of a certain sensation, and feelings are to be distinguished from sensations. Red, warm and bitter, along with many others, are sensations, but pleasantness and unpleasantness are not sensations.

✕ How, then, do the elementary feelings differ from sensations? In the first place, sensations submit readily to being picked out and observed, and in fact become more vivid when they are brought into the "foreground", while feelings grow vague and lose their character when thus singled

out for examination. Attend to the noises in the street and they stand out clearly, attend to the internal sensation of breathing and it stands out clearly, but attend to your pleasant state of feeling and it retreats out of sight.

In the second place, sensations are "localized"; you can tell pretty well where they seem to come from. Sensations of light, sound and smell are localized outside the body, sensations of touch are localized on the skin (or sometimes outside), taste sensations are localized in the mouth, organic and muscular sensations in some part of the body. On the other hand, pleasantness and unpleasantness are much less definitely localized; they seem to be "in us", without being in any special part of us.

In the third place, feelings differ from sensations in having no known sense organs. There is no special sense organ or set of sense organs for the feeling of pleasantness or unpleasantness, as there is for warmth or cold. Some sensations are pleasant, to be sure, and some unpleasant; but there is no one kind of sense organ that has the monopoly of either sort of feeling.

FEELING-TONE OF SENSATIONS

The pleasantness or unpleasantness characteristic of many sensations is called their "feeling-tone", and sensations that are markedly pleasant or unpleasant are said to have a strong or pronounced feeling-tone. Bitter is intrinsically unpleasant, sweet pleasant, the salty taste, when not too strong, neither one nor the other, so that it has no definite feeling-tone. Odors, as well as tastes, usually have a rather definite feeling-tone. Of sounds, smooth tones are pleasant, grating noises unpleasant. Bright colors are pleasant, while dull shades are sometimes unpleasant, sometimes merely indifferent or lacking in feeling-tone. Pain is usually unpleasant, moderate warmth and cold pleasant, simple touch

indifferent. Very intense sensations of any kind are likely to be unpleasant.

The statements made above as to the subjectivity and non-localization of feeling do not apply altogether to the feeling-tone of sensations. The pleasantness or unpleasantness of a sensation is localized with the sensation and seems to belong to the object rather than to ourselves. The unpleasantness of a toothache seems to be in the tooth rather than simply "in us". The pleasantness of a sweet taste is localized in the mouth, and we even think of the sweet substance as being objectively pleasant. We say that it is a "pleasant day", and that there is a "pleasant tang in the air", as if the pleasantness were an objective fact.

By arguing with a person, however, you can get him to admit that, while the day is pleasant *to him*, and the tang in the air pleasant to him, they may be unpleasant to another person; and he will admit that a sweet substance, ordinarily pleasant, is unpleasant when he has had too much of sweet things to eat. So you can make him realize that pleasantness and unpleasantness depend on the individual and his condition, and are subjective rather than objective. Show a group of people a bit of color, and you will find them agreeing much better as to what color that is than as to how pleasant it is. Feeling-tone is subjective in the sense that people disagree about it.

THEORIES OF FEELING

1. Pleasantness might represent a general *organic state*, and unpleasantness the contrary state, each state being an internal bodily response to pleasant or unpleasant stimuli, and making itself felt as an unanalyzable compound of vague internal sensations.

This theory of feeling is certainly attractive, and it would

account very well for all the facts so far stated, for the subjectivity of feeling, for its lack of localization, and for the absence of specific sense organs for the feelings. It would bring the feelings into line with the emotions. But the real test of the theory lies just here: can we discover radically different organic states for the two opposite feelings?

Numerous experiments have been conducted in the search for such radically different organic states, but thus far the search has been rather disappointing. Arrange to record the subject's breathing and heart beat, apply pleasant and unpleasant stimuli to him, and see whether there is any characteristic organic change that goes with pleasant stimuli, and an opposite change with unpleasant stimuli. You should also obtain an introspective report from your subject, so as to be sure that the "pleasant stimuli" actually gave a feeling of pleasantness, etc. Certain experiments of this sort have indicated that with pleasantness goes slower heart beat and quicker breathing, with unpleasantness quicker heart beat and slower breathing. But not all investigators have got these results; and, anyway, it would be impossible to generalize to the extent of asserting that slow heart beat always gave a pleasant state of feeling, and rapid heart beat an unpleasant; for there is slow heart beat during a "morning grouch", and rapid during joyful expectation. Or, in regard to breathing, try this experiment: hasten your breathing and see whether a feeling of pleasantness results; slacken it and see whether unpleasantness results. The fact is that pleasantness can go with a wide range of organic states, so far as these are revealed by heart beat and breathing; and the same with unpleasantness. If there is any organic fact definitely characteristic of either state of feeling, it is a subtle fact that has hitherto eluded observation.

2. Pleasantness might represent smooth and easy *brain action*, unpleasantness slow and impeded brain action. According to this theory, unimpeded progress of nerve currents through the brain is pleasant, while resistance encountered at the brain synapses is unpleasant. A stimulus is pleasant, then, because the nerve currents started by it find smooth going through the brain centers, and another stimulus is unpleasant because it finds the going poor.

While this theory looks good in some ways, and fits some cases very well—as the great unpleasantness of blocked reaction, where you cannot make up your mind what to do—there are two big objections to it. The first objection is found in the facts of practice. Practising any reaction makes it more and more smooth-running and free from inner obstruction, and should therefore make it more and more pleasant; but, as a matter of fact, practising an unfamiliar act of any sort makes it more pleasant for a time only, after which continued practice makes it automatic and neither pleasant nor unpleasant. The smoothest reactions, which should give the highest degree of pleasant feeling according to the theory, are simply devoid of all feeling.

The second objection lies in the difficulty of believing unpleasant stimuli to give slow, impeded reactions. On the contrary, the instinctive defensive reactions to unpleasant stimuli are very quick, and give no sign of impeded progress of nerve currents through the brain centers.

3. There is one fact, not yet taken into account, that may point the way to a better theory. Feeling is *impulsive*. In pleasantness, the impulse is to “stand pat” and let the pleasant state continue; in unpleasantness, the impulse is to end the state. The impulse of pleasantness is directed towards keeping what is pleasant, and the impulse of unpleasantness is directed towards getting rid of the unpleasant. In indifference there is no tendency either to keep or to be

rid of. These facts are so obvious as scarcely to need mention, yet they may be the core of this whole matter of feeling. Certainly they are the most important facts yet brought out as relating feeling to conduct.

Putting this fact into neural terms, we say that pleasantness goes with a neural adjustment directed towards keeping, towards letting things stay as they are; while unpleasantness goes with an adjustment towards riddance. Bitter is unpleasant because we are so organized, by native constitution, as to make the riddance adjustment on receiving this particular stimulus. In plain language, we seek to be rid of it, and that is the same as saying it is unpleasant. Sweet is pleasant for a similar reason.

There is some evidence that these adjustments occur in that part of the brain called the thalamus.¹

SOURCES OF PLEASANTNESS AND UNPLEASANTNESS

Laying aside now the difficult question of the organic and cerebral nature of the feelings, we turn to the simpler question of the stimuli that arouse them. A very important fact immediately arrests our attention. There are two different kinds of stimuli for pleasantness, and two corresponding kinds for unpleasantness. The one kind is typified by sweet and bitter, the other by success and failure. Some things are pleasant (or unpleasant) without regard to any already awakened desire, while other things are pleasant (or unpleasant) only because of such a desire. A sweet taste is pleasant even though we were not desiring it at the moment, and a bitter taste is unpleasant though we had no expectation of getting it and no desire awakened to avoid it. On the other hand, the sight of our stone hitting the tree is pleasant only because we were aiming at the tree, and

¹ See p. 65.

the sight of the stone going to one side of the tree is unpleasant just for the same reason.

Some things we want,
Because we like them;
Some things we like,
Because we want them.

We want candy, because we like the sweet taste; but we like a cold drink because and when we are thirsty and not otherwise. Thirst is a want for water, a state of the organism that impels us to drink; and when we are in this state, we like a drink, a drink is pleasant then. How absurd it would be to say that we were thirsty because we liked to drink! when the fact is that we like to drink because we are thirsty. The desire to drink must first be aroused, and then drinking is pleasant.

What is true of thirst is true of hunger, or of any organic need. The need must first be aroused, and then its satisfaction is pleasant. This applies just as well to fighting, laughing, fondling a baby, and to all the instincts. It gives you no pleasure to strike or kick a person, or to swear at him, unless you are first angry with him. It gives you no pleasure to go through the motions of laughing unless you "want to laugh", i.e., unless you are amused. It gives you no pleasure to fondle the baby unless you love the baby. Let any instinct be first aroused, and then the result at which the instinct is aimed causes pleasure, but the same result will cause no pleasure unless the instinct has been aroused.

The same can be said of desires that are not exactly instinctive. At a football game, for example, when one of the players kicks the ball and it sails between the goal posts, half of the spectators yell with joy, while the other half

groan in agony. Why should the appearance of a ball sailing between two posts be so pleasant to some, and unpleasant to others? This particular appearance is by itself neither pleasant nor unpleasant, but because the desire to see this happen has been previously aroused in the partisans of one team, and the desire that it should not happen in the partisans of the other, therefore it is that the pleasantness or unpleasantness occurs. First arouse any desire, and then you can give pleasure by gratifying it, displeasure by thwarting it. This is the pleasure of success, and the unpleasantness of failure.

Pleasures of this class may be named secondary, because they depend upon pre-aroused desires.

PRIMARY LIKES AND DISLIKES

Though many of the most intense pleasures and displeasures of life are of the secondary type, this fact must not blind us to the existence of the primary pleasures and displeasures, typified by sweet and bitter. Any sensation with a pronounced feeling-tone is a primary pleasure or displeasure. We like or dislike it just for itself, and without regard to the gratification of any pre-aroused instinct or desire.

There are natural likes and dislikes—apart from the satisfaction of instincts—and there are others that are acquired. In other words, there are native tastes and acquired tastes. Individuals differ considerably in their native tastes, and still more in their acquired tastes. Liking for sweets is native, liking for fragrant odors is native, but liking for lemonade, or black coffee, or olives, or cheese, is acquired, and not acquired by everybody. Liking for bright colors is native, but liking for subdued colors, and the special pleasure in color harmonies, are acquired. So we might

run through the list of the senses, finding under each some sensations with native feeling-tone, and other sensations that acquire feeling-tone through experience.

Some people have a native liking for numbers and other facts of a mathematical nature. We say of such a one that he has a natural taste for mathematics. Another has a natural dislike for the same. Some have a taste for things of the mechanical sort, others fight shy of such things. Some have a natural taste for people, being sociable creatures—which means more than being gregarious—while others are little interested in mixing with people, observing their ways, and the give and take of friendly intercourse.

Now the question arises whether these native likes and dislikes, for odors, colors, tones, numbers, machinery, and people, are really independent of the instincts. Some psychologists have insisted that all the interest and satisfaction of life were derived from the instincts, laying special stress on the instincts of curiosity and self-assertion.

With respect to our “natural liking for mathematics”, these psychologists would argue as follows: “First off, curiosity is aroused by numbers, as it may be by any novel fact; then the child, finding he can do things with numbers, gratifies his mastery impulse by playing with them. He encounters number problems, and his mastery impulse is again aroused in the effort to solve the problems. Later, he is able to ‘show off’ and win applause by his mathematical feats, and thus the social form of self-assertion is brought into play. This particular child may have good native ability for mathematics, and consequently his mastery impulse is specially gratified by this kind of activity; but he has no real direct liking for mathematics, and all his industry in this field is motivated by curiosity and especially by self-assertion.”

The instinct psychologists have a strong case here, as

they would have also in regard to the liking for machinery. Still, the mathematical individual would not be convinced, for he would testify that numbers, etc., made a direct appeal to him. Numbers, geometric forms, and algebraic transformations are fascinating to him, and there is something beautiful, to his mind, in the relationships that are discovered. The same could be said of the liking for plant or animal life that appears in the "born biologist". If the objects of the world make a direct appeal to the man whose mind is attuned to them, then his interest and zeal in studying them are not wholly derived from the instincts. The instincts come into play, truly enough, in all scientific work, and add impetus to it, but the primary motive is a direct liking for the kind of facts studied.

"Primary likes and dislikes" are still more clearly in evidence in the arts than in the sciences. Take the color art, for example. There can be no manner of doubt that bright colors are natively pleasant. Can we explain the liking for color as derived from satisfaction of the instincts? Is it due simply to curiosity? No, for then the color would no longer be attractive after it had ceased to be a novelty. Is color liked simply for purposes of self-display? No, this would not explain our delight in the colors of nature. Or do color effects constitute problems that challenge the mastery impulse? This might fit the case of intricate color designs, but not the strong, simple color effects that appeal to most people. There is no escape from the conclusion that color is liked for its own sake, and that this primary liking is the foundation of color art.

Music, in the same way, is certainly based on a primary liking for tones and their combinations, as well as for rhythm. Novel effects also appeal to curiosity, musical performance is a means of display to the performer, and the problem set by a piece of music to the performer in the

way of execution, and to the listener in the way of understanding and appreciation, gives plenty of play to the mastery impulse. Besides, music gets associated with love, tenderness, war and religion; but none of the impulses thus gratified by music is the fundamental reason for music, since without the primary taste for tone and rhythm there would be no music to start with, and therefore no chance for these various impulses to find an outlet in this direction.

Still another field of human activity, in which native likes and dislikes play their part alongside of the instincts, is the field of social life. The gregarious instinct brings individuals together into social groups, and probably also makes the individual crave participation in the doings of the group. The sex instinct lends a special interest to those members of the group who are of the opposite sex, and the parental instinct leads the adults to take a protective attitude towards the little children. Also, it is probably due to the parental instinct that any one spontaneously seeks to help the helpless. Self-assertion has plenty of play in a group, both in the way of seeking to dominate and in the way of resisting domination; and the submissive tendency finds an outlet in admiring and following those who far surpass us. Thwarted self-assertion accounts for many of the dislikes that develop between the members of a group. But none of these instincts accounts for the interest in personality, or for the genuine liking that people may have for one another.

Let a group of persons of the same age and sex get together, all equals for the time being, no one seeking to dominate the rest, no one bowing to another as his superior nor chafing against an assumed superiority which he does not admit, no one in a helpless or unfortunate condition that arouses the pity of the rest. What an uninteresting affair! No instincts called into play except bare gregariousness!

On the contrary, such a group affords almost or quite the maximum of social pleasure. It affords scope for comradeship and good fellowship, which are based on a native liking for people, and not on the instincts.

Enough has perhaps been said to convince the reader that, besides the things we like for satisfaction of our instinctive needs and cravings, there are other things that we "just naturally like"—and the same with dislikes—and that these primary likes and dislikes have considerable importance in life.

OTHER PROPOSED ELEMENTARY FEELINGS

Pleasantness and unpleasantness are the only feelings generally accepted as elementary, though several others have been suggested.

Wundt's tri-dimensional theory of feeling. This author suggested that there were three pairs of feelings: pleasantness and unpleasantness; tension and its opposite, release or relief; and excitement and its opposite, which may be called numbness or subdued feeling. Thus there would be three dimensions of feeling, which could be represented by the three dimensions of space, and any given state of feeling could be described by locating it along each of the three dimensions. Thus, one moment, we may be in a pleasant, tense, excited state; another moment in a pleasant, relieved and subdued state; and another moment in an unpleasant, tense and subdued state, etc. As each feeling can also exist in various degrees, the total number of shades of feeling thus provided for would be very great, indeed.

Though this theory has awakened great interest, it has not won unqualified approval. Excitement and the rest are real enough states of feeling—no one doubts that—but the question is whether they are fit to be placed alongside of pleasantness and unpleasantness as elementary feelings. It

appears rather more likely that they are blends of sensations. In the excited states that have been most carefully studied, that is to say, in fear and anger, there is that big organic upstir, making itself felt as a blend of many internal sensations. Tension may very probably be the feeling of tense muscles, for tension occurs specially in expectancy, and the muscles are tense then.

Whether elementary or not, these feelings are worthy of note. It is interesting to examine the striving for a goal and the attainment of the goal with respect to each "dimension" of feeling. Striving is tense, attainment brings the feeling of release. Striving is often excited, but fatigue and drowsiness (seeking for rest) are numb, and self-assertion may be neutral in this respect, as in "cool assumption". Reaching the goal may be excited or not; all depends on the goal, whether it be striking your opponent or going to sleep. On the other hand, reaching the goal is practically always pleasant (weeping seems an exception here), while striving for a goal is pleasant or unpleasant according as progress is being made towards the goal, or stiff obstruction encountered.

The feeling of familiarity, and its opposite, the feeling of strangeness or newness, also have some claim to be considered here. The first time you see a person, he seems strange, the next few times he awakens in you the feeling of familiarity, after which he becomes so much a matter of course as to arouse no definite feeling of this sort, unless, indeed, a long time has elapsed since you saw him last; in this case the feeling of familiarity is particularly strong.

The feelings of doubt or hesitation, and of certainty or assurance, also deserve mention as possibly elementary.

EXERCISES

1. Outline the chapter.
2. Complete the sentence, "I feel *like hell* in 20 different ways (not using synonyms), and measure the time required to do this.
3. What can be meant by speaking in psychology of only two feelings, when common speech recognizes so many?
4. If the states of mind designated by the words, "feeling sure", or "feeling bored", are compound states, what elements besides the feelings of pleasantness and unpleasantness may enter into the compounds?
5. Attempt an analysis of the "worried feeling", by your own introspection, i.e., try to discover elementary feelings and sensations in this complex state of mind.
6. Following Wundt's three-dimensional scheme of feeling, analyze each of the following states of mind (for example, a child just admitted to the presence of the Christmas tree would be in a state of mind that is pleasant, tense, and excited):
 - (a) Watching a rocket go up and waiting for it to burst.
 - (b) Just after the rocket has burst.
 - (c) Waiting for the dentist to pull.
 - (d) Just after he has pulled.
 - (e) Enjoying a warm bed.
 - (f) Lying abed after waking, not quite able as yet to decide to get up.
 - (g) Seeing an automobile about to run down a child.
7. Make a list of six primary dislikes, and a list of six dislikes that are dependent on the instincts.

REFERENCES

For a much fuller treatment of the subject, see E. B. Titchener, *Textbook of Psychology*, 1909, pp. 225-264.

CHAPTER X

SENSATION

AN INVENTORY OF THE ELEMENTARY SENSATIONS OF THE DIFFERENT SENSES

With reflex action, instinct, emotion and feeling, the list of native mental activities is still incomplete. The *senses* are provided by nature, and the fundamental use of the senses goes with them. The child does not learn to see or hear, though he learns the meaning of what he sees and hears. He gets sensation as soon as his senses are stimulated, but recognition of objects and facts comes with experience. Hold an orange before his open eyes, and he sees, but the first time he doesn't see *an orange*. The adult sees an object, where the baby gets only sensation. "Pure sensation", free from all recognition, can scarcely occur except in the very young baby, for recognition is about the easiest of the learned accomplishments, and traces of it can be seen in the behavior of babies only a few days old.

Sensation is a response; it does not come to us, but is aroused in us by the stimulus. It is the stimulus that comes to us, and the sensation is our own act, aroused by the stimulus. Sensation means the activity of the receiving organ (or sense organ), of the sensory nerves, and of certain parts of the brain, called the sensory centers. Without the brain response, there is apparently no conscious sensation, so that the activity of the sense organ and sensory nerve is preliminary to the sensation proper. Sensation may be called the first response of the brain to the external stimulus. It is usually only the first in a series of brain

responses, the others consisting in the recognition of the object and the utilization of the information so acquired.

Sensation, as we know it in our experience, goes back in the history of the race to the primitive sensitivity (or irritability) of living matter, seen in the protozoa. These minute unicellular creatures, though having no sense organs—any more than they have muscles or digestive organs—respond to a variety of stimuli. They react to mechanical stimuli, as a touch or jar, to chemical stimuli of certain kinds, to thermal stimuli (heat or cold), to electrical stimuli, and to light. There are some forces to which they do not respond: magnetism, X-rays, ultraviolet light; and we ourselves are insensitive to these agents, which are not to be called stimuli, since they arouse no response.

THE SENSE ORGANS

In the development of the metazoa, or multicellular animals, specialization has occurred, some parts of the body becoming muscles with the primitive motility much developed, some parts becoming digestive organs, some parts conductors (the nerves) and some parts becoming specialized receptors or sense organs. A sense organ is a portion of the body that has very high sensitivity to some particular kind of stimulus. One sense organ is highly sensitive to one stimulus, and another to another stimulus. The eye responds to very minute amounts of energy in the form of light, but not in other forms; the ear responds to very minute amounts of energy in the form of sound vibrations, the nose to very minute quantities of energy in certain chemical forms.

There is only one thing that a sense organ always and necessarily contains, and that is the *termination of a sensory nerve*. Without that, the sense organ, being isolated, would have no effect on the brain or muscles or any other

part of the body, and would be entirely useless. The axons of the sensory nerve divide into fine branches in the sense organ, and thus are more easily aroused by the stimulus.

Besides the sensory axons, two other things are often found in a sense organ—sometimes one of the two, sometimes the other and sometimes both. First, there are special sense cells in a few sense organs; and second, in most sense

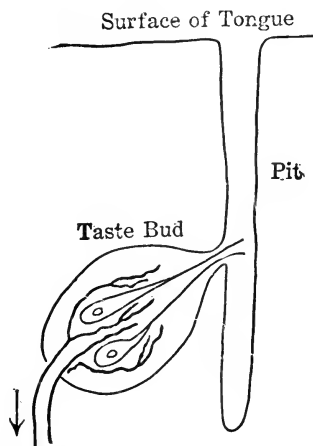

FIG. 25.—Diagram of the taste end-organ. Within the "Taste bud" are seen two sense cells, and around the base of these cells are seen the terminations of two axons of the nerve of taste.

organs there is accessory apparatus which, without being itself sensitive, assists in bringing the stimulus to the sense cells or sensory nerve ends.

Sense cells are present only in the eye, ear, nose and mouth—always in very sheltered situations. The taste cells are located in little pits opening upon the surface of the tongue. In the sides of these pits can be found little flask-shaped chambers, each containing a number of taste cells. The taste cell has a slender prolongation that protrudes from the chamber into the pit; and it is this slender tip of the cell that is exposed to the chemical stimulus of the tast-

ing substance. The stimulus arouses the taste cell, and this in turn arouses the ending of the sensory axon that twines about the base of the cell at the back of the chamber. The taste cell, or its tip, is extra sensitive to chemical stimuli, and its activity, aroused by the chemical stimulus, in turn arouses the axon and so starts a nerve current to the brain stem and eventually to the cortex.

The olfactory cells, located in a little recess in the upper and back part of the nose, out of the direct air currents

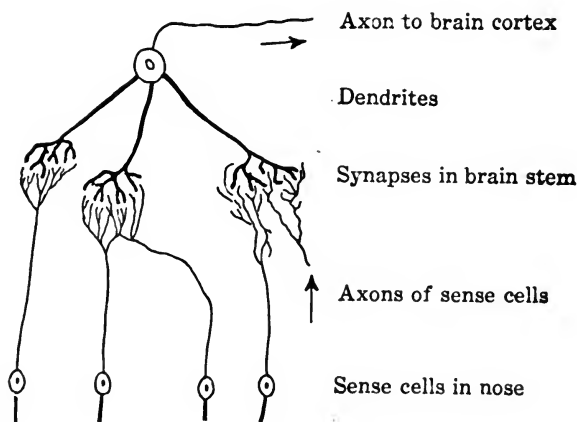

FIG. 26.—The olfactory sense cells and their brain connections.

going toward the lungs, are rather similar to the taste cells. They have fine tips reaching to the surface of the mucous membrane lining the nasal cavity and exposed to the chemical stimuli of odors. The olfactory cell has also a long slender branch extending from its base through the bone into the skull cavity and connecting there with dendrites of nerve cells. This central branch of the olfactory cell is, in fact, an axon; and it is peculiar in being an axon growing from a sense cell. This is the rule in invertebrates, but in vertebrates the sensory axon is regularly an outgrowth of a

nerve cell, and only in the nose do we find sense cells providing their own sensory nerve.

In the eye, the sense cells are the rods and cones of the retina. These are highly sensitive to light, or, it may be, to chemical or electrical stimuli generated in the pigment of

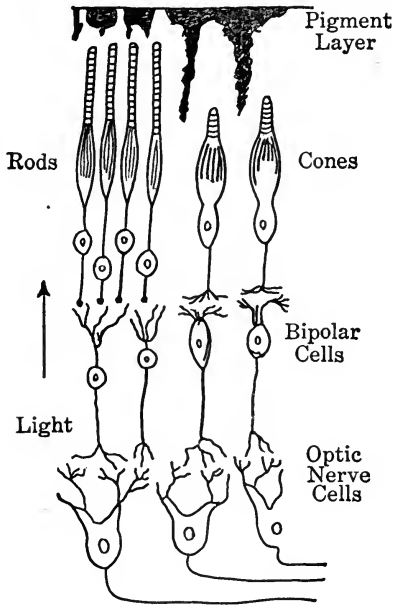

FIG. 27.—Sense cells and nerve cells of the retina. Light, reaching the retina from the interior of the eyeball (as shown in Fig. 28), passes through the nearly transparent retina till stopped by the pigment layer, and then and there arouses to activity the tips of the rods and cones. The rods and cones pass the impulse along to the bipolar cells and these in turn to the optic nerve cells, the axons of which extend by way of the optic nerve to the thalamus in the brain.

the retina by the action of light. The rods are less highly developed than the cones. Both rods and cones connect at their base with neurones that pass the activity along through the optic nerve to the brain.

The internal ear contains sense cells of three rather similar kinds, all being "hair cells". Instead of a single

sensitive tip, each cell has a number of fine hair-tips, and it is these that first respond to the physical stimulus. In the cochlea, the part of the inner ear concerned with hearing, the hairs are shaken by sound vibrations that have reached the liquid in which the whole end-organ is immersed. In the "semicircular canals", a part of the inner ear that is concerned not with sound but with rotary movements of the head, we find hair cells again, their hair-tips being matted together and so located as to be bent, like reeds growing on the bottom of a brook, by currents of the liquid filling the canals. In the "vestibule", the central part of the inner ear, the hair-tips of the sense cells are matted together, and in the mat are imbedded little particles of stony matter, called the "otoliths". When the head is inclined in any direction, these heavy particles sag and bend the hairs, so stimulating them; and the same result occurs when a sudden motion up or down or in any direction is given to the head. Around the base of the sense cells, in any of these parts of the internal ear, are twined the fine endings of sensory axons, which are excited by the activity of the sense cells, and pass the activity on to the brain.

Accessory sense-apparatus. Every sense except the "pain sense" has more or less of this. The hairs of the skin are accessory to the sense of touch. A touch on a hair is so easily felt that we often think of the hairs as sensitive; but really it is the skin that is sensitive, or, rather, it is the sensory axon terminating around the root of the hair in the skin. The tongue can be thought of as accessory apparatus serving the sense of taste, and the breathing apparatus as accessory to the sense of smell, "tasting" being largely a tongue movement that brings the substance to the taste cells, and "smelling" of anything being largely a series of little inspiratory movements that carry the odor-laden air to the olfactory part of the nasal cavity.

But it is in the eye and the ear that the highest development of accessory sense apparatus has taken place. All of the eye except the retina, and all of the ear except the sense cells and the sensory axons, are accessory.

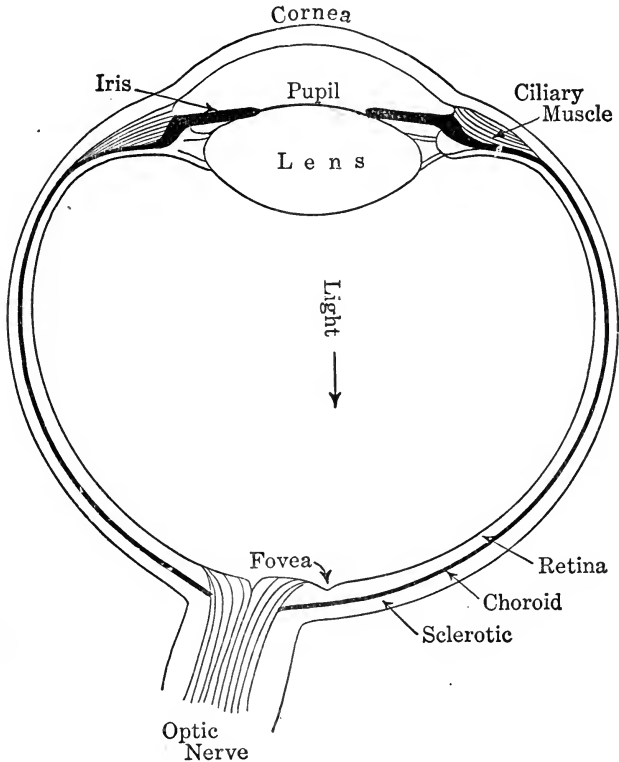

FIG. 28.—Horizontal cross section through the right eyeball.

The eye is an optical instrument, like the camera. In fact, it is a camera, the sensitive plate being the retina, which differs indeed from the ordinary photographic plate in recovering after an exposure so as to be ready for another. Comparing the eye with the camera, we see that the eyeball corresponds to the box, the outer tough coat

of the eyeball (the "sclerotic" coat) taking the place of the wood or metal of which the box is built, and the deeply pigmented "choroid coat, that lines the sclerotic, corresponding to the coating of paint used to blacken the inside of the camera box and prevent stray light from getting in and blurring the picture. At the front of the eye, where

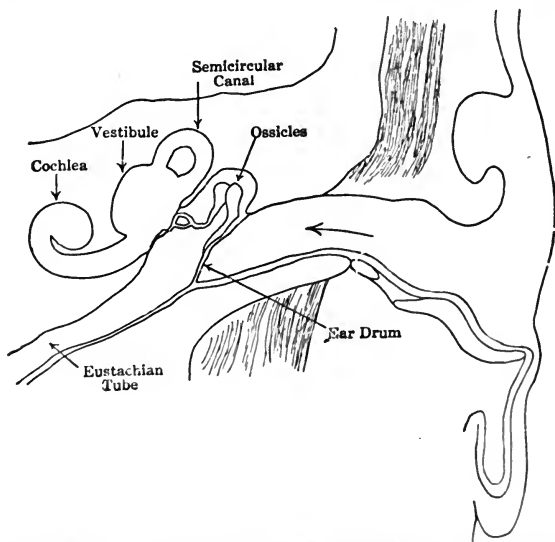

FIG. 29.—Diagram to show the course of the sound waves through the outer and middle ear and into the inner ear. The arrow is placed within the "meatus," and points in the direction taken by the sound waves. See text for their further course.

light is admitted, the sclerotic is transformed into the transparent "cornea", and the choroid into the contractile "iris", with the hole in its center that we call "the pupil of the eye". The iris corresponds to the adjustable diaphragm of the camera. Just behind the pupil is the lens of the eye, which also is adjustable by the action of a little muscle, called the "ciliary muscle". This muscle corresponds to the focussing mechanism of the camera; by it the eye is focussed on near or far objects. The eye really

has two lenses, for the cornea acts as a lens, but is not adjustable. The "aqueous and vitreous humors" fill the eyeball and keep it in shape, while still, being transparent, they allow the light to pass through them on the way to the retina. The retina is a thin coat, lying inside the choroid at the back of the eyeball, and having the form of a hollow hemisphere. The light, coming through the pupil and traversing the vitreous humor, strikes the retina from the inside

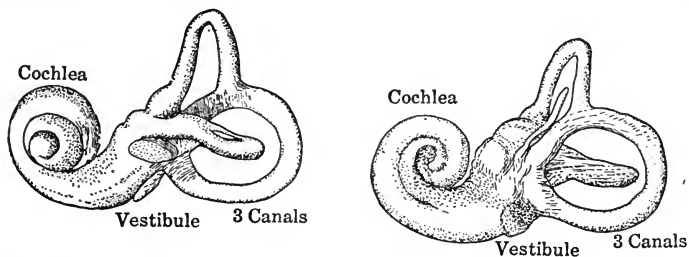

FIG. 30.—Two views of the internal ear. These views show the shape of the internal ear cavity. The sense organs lie inside this cavity. Notice how the three semi-circular canals lie in three perpendicular planes.

of the eyeball. Other accessory apparatus of the eye includes the lids, the tear glands, and the muscles that turn the eyeball in any direction.

The ear is about as complex a piece of mechanism as the eye. We speak of the "outer", "middle" and "inner" ear. The outer, in such an animal as the horse, serves as a movable ear trumpet, catching the sound waves and concentrating them upon the ear drum, or middle ear. The human external ear seems to accomplish little; it can be cut off without noticeably affecting hearing. The most essential part of the external ear is the "meatus" or hole that allows the sound waves to pass through the skin to the tympanic membrane or drum head. The sound waves throw this membrane into vibration, and the vibration is transmitted, by an assembly of three little bones, across the air-filled cavity

of the middle ear to an opening leading to the water-filled cavity of the inner ear. This opening from the middle to the inner ear is closed by a membrane in which one end of the assembly of little bones is imbedded, as the other end is imbedded in the tympanic membrane; and thus the vibrations are transmitted from the tympanic membrane to the liquid of the inner ear. Once started in this liquid, the

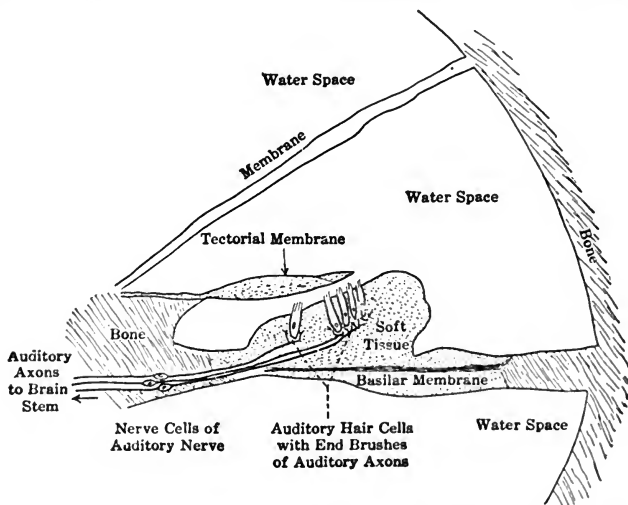

FIG. 31.—A small sample of the sense cells of the cochlea. The hairs of the sense cells are shaken by the vibration of the water, and pass the impulse back to the end-brushes of the auditory axons. The tectorial membrane looks as if it might act as a damper, but may be concerned, as "accessory apparatus," in the stimulation of the hair cells. The basilar membrane consists in part of fibers extending across between the ledges of bone; these fibers are arranged somewhat after the manner of piano strings, and have suggested the "piano theory" of hearing, to be mentioned later in the chapter.

vibrations are propagated through it to the sense cells of the cochlea and stimulate them in the way already suggested.

Further study of the accessory apparatus of the eye and ear can be recommended as very interesting, but the little that has been said will serve as an introduction to the study of sensation.

ANALYSIS OF SENSATIONS

Prominent among the psychological problems regarding sensation is that of analysis. Probably each sense gives comparatively few elementary sensations, and many blends or compounds of these elements. To identify the elements is by no means a simple task, for under ordinary circumstances what we get is a compound, and it is only by carefully controlling the stimulus that we are able to get the elements before us; and even then the question whether these are really elementary sensations can scarcely be settled by direct observation.

Along with the search for elementary sensations goes identification of the stimuli that arouse them, and also a study of the sensations aroused by any combination of stimuli. Our task now will be to ask these questions regarding each of the senses.

THE SKIN SENSES

Rough and smooth, hard and soft, moist and dry, hot and cold, itching, tickling, pricking, stinging, aching are skin sensations; but some of these are almost certainly compounds. The most successful way of isolating the elements out of these compounds is to explore the skin, point by point, with weak stimuli of different kinds. If a blunt metal point, or the point of a lead pencil, a few degrees cooler than the skin, is passed slowly over the skin, at most points no sensation except that of contact arises, but at certain points there is a clear sensation of cold. Within an area an inch square on the back of the hand, several of these *cold spots* can be found; and when the exploration is carefully made, and the cold spots marked, they will be found to give the same sensation every time. Substitute a metal point a few

degrees warmer than the skin, and a few spots will be found that give the sensation of warmth, these being the warmth spots. Use a sharp point, like that of a needle or of a sharp bristle, pressing it moderately against the skin, and you get at most points simply the sensation of contact, but at quite a number of points a small, sharp pain sensation arises. These are the pain spots. Finally, if the skin is explored with a hair of proper length and thickness, no sensation at all will be felt at most points, because the hair bends so readily when one end of it is pressed against the skin as not to exert sufficient force to arouse a sensation; but a number of points are found where a definite sensation of touch or contact is felt; these are the touch spots.

No other varieties of "spots" are found, and the four sensations of touch, warmth, cold and pain are believed to be the only elementary skin sensations. Itch, stinging and aching seem to be the same as pain. Tickle is touch, usually light touch or a succession of light touches. Smooth and rough are successions of touch sensations. Moist is usually a compound of smooth and cold. Hard and soft combine touch and the muscular sensation of resistance.

Hot and cold require more discussion. The elementary sensations are warmth and coolness, rather than hot and cold. Hot and cold are painful, and the fact is that strong temperature stimuli arouse the pain spots as well as the warmth or cold spots. Hot, accordingly, is a sensation compounded of warmth and pain, and cold a sensation composed of coolness and pain. More than this, when a cold spot is touched with a point heated well above the skin temperature (best to a little over 100° Fahrenheit), the curious fact is noted that the cold spot responds with its normal sensation of cold. This is called the "paradoxical cold sensation". From this fact it is probable that a hot object excites the cold sensation, along with those of warmth and

pain; so that the sensation of heat is a blend of the three. Another curious fact is that a very cold object produces a burning sensation indistinguishable from that of a hot object; so that the sensation of great cold, like that of heat,

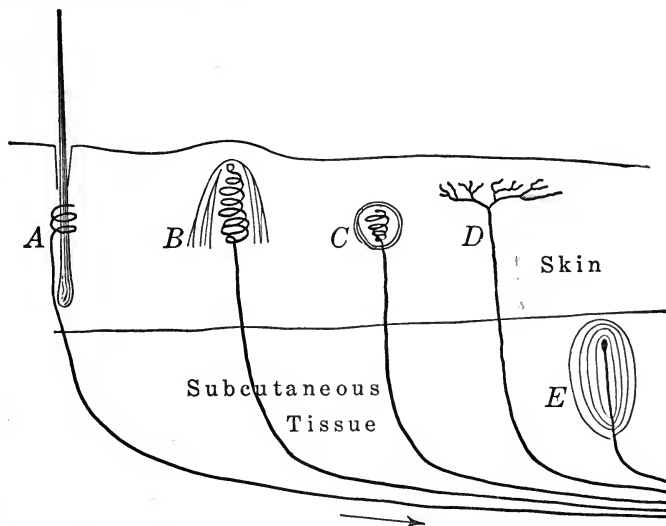

FIG. 32.—Diagram of various sorts of sensory end-organ found in the skin.

A is a hair end-organ; the sensory axons can be seen coiling around the root of the hair; evidently a touch on the hair, outside, would squeeze the coiled axon and stimulate it. The hair is a bit of "accessory apparatus."

B is a touch corpuscle, consisting of a coiled axon-end surrounded by a little cone of other tissue.

C is an end-bulb, presumably belonging to the temperature sense. It has, again, a coiled axon-end surrounded by other tissue. The "coils" are really much more finely branched than the diagram shows.

D is a free-branched nerve end, consisting simply of a branched axon, with no accessory apparatus. It is the pain-sense organ.

E is a corpuscle of a type found in the subcutaneous tissue, as well as in more interior parts of the body. It contains an axon-end surrounded by a layered capsula.

is probably a blend of the three elementary sensations of warmth, cold and pain.

The stimulus that arouses the touch sensation is a bending of the skin. That which arouses warmth or cold is of

course a temperature stimulus, but, strange as it may seem, the exact nature of the effective stimulus has not been agreed upon. Either it is a warming or cooling of the skin, or it is the existence of a higher or lower temperature in the skin than that to which the skin is at the moment "adapted". This matter will become clearer when we later discuss adaptation. The stimulus that arouses the pain sensation may be mechanical (as a needle prick), or thermal (heat or cold), or chemical (as the drop of acid), or electrical; but in any case it must be strong enough to injure or nearly to injure the skin. In other words, the pain sense organ is not highly sensitive, but requires a fairly strong stimulus; and thus it is fitted to give warning of stimuli that threaten injury.

Several kinds of sensory end-organ are found in the skin. There is the "spherical end-bulb", into which a sensory axon penetrates; it is believed to be the sense organ for cold. There is the rather similar "cylindrical end-bulb" believed to be the sense organ for warmth. There is the "touch corpuscle", found in the skin of the palms and soles, and consisting, like the end-bulbs, of a mass of accessory cells with a sensory axon ramifying inside it; this is an end-organ for the sense of touch. There is the hair end-organ, consisting of a sensory axon coiled about the root of the hair; this, also, is a touch receptor. Finally, there is the "free-branched nerve end", consisting simply of the branching of a sensory axon, with no accessory apparatus whatever; and this is the pain receptor. Perhaps the pain receptor requires no accessory apparatus because it does not need to be extremely sensitive.

Now since we find, in the skin, "spots" responsive to four quite different stimuli, giving four quite different sensations, and apparently provided with different types of end-organs, it has become customary to speak of four skin senses in place of the traditional "sense of touch". We

speak of the pain sense, the warmth sense, the cold sense, and the pressure sense, which last is the sense of touch proper.

THE SENSE OF TASTE

Analysis has been as successful in the sense of taste as in cutaneous sensation. Ordinarily we speak of an unlimited number of tastes, every article of food having its own characteristic taste. Now the interior of the mouth possesses the four skin senses in addition to taste, and many tastes are in part composed of touch, warmth, cold or pain. A "biting taste" is a compound of pain with taste proper, and a "smooth taste" is partly touch. The consistency of the food, soft, tough, brittle, gummy, also contributes, by way of the muscle sense, to the total "taste". But in addition to all these sensations from the mouth, the flavor of the food consists largely of odor. Food in the mouth stimulates the sense of smell along with that of taste, the odor of the food reaching the olfactory organ by way of the throat and the rear passage to the nose. If the nose is held tightly so as to prevent all circulation of air through it, most of the "tastes" of foods vanish; coffee and quinine then taste alike, the only *taste* of each being bitter, and apple juice cannot be distinguished from onion juice.

But when the nose is excluded, and when cutaneous and muscular sensations are deducted, there still remain a few genuine tastes. These are sweet, sour, bitter and salty—and apparently no more. These four are the elementary taste sensations, all others being compounds. The papillae of the tongue, with their little "pits" already spoken of, correspond to the "spots" of the skin, with this difference, however, that the papillae do not each give a single sensation. Some of them give only two, some only three of the four tastes; and the bitter taste is aroused principally from

the back of the tongue, the sweet from the tip, the sour from the sides, the salty from both tip and sides.

The stimulus to the sense of taste is something of a chemical nature. The tasteable substances must be in solution in order to penetrate the pits and get to the sensitive tips of the taste cells. If the upper surface of the tongue is first dried, a dry lump of sugar or salt laid on it gives no sensation of taste until a little saliva has accumulated and dissolved some of the substance.

Exactly what is the chemical agent that produces a given taste sensation is a problem of some difficulty. Many different substances give the sensation of bitter, and the question is, what there is common to all these substances. The sweet taste is aroused not only by sugar, but by glycerine, saccharine, and even "sugar of lead" (lead acetate). The sour taste is aroused by most acids, but not by all, and also by some substances that are not chemically acids. Thus the chemistry of taste stimuli involves something not as yet understood.

Though there is this uncertainty regarding the stimulus, on the whole the sense of taste affords a fine example of success achieved by experimental methods in the analysis of complex sensations. At the same time it affords a fine example of the fusion of different sensations into characteristic *blends*. The numerous "tastes" of every-day life, though found on analysis to be compounded of taste, smell, touch, pain, temperature and muscle sensations, have the effect of units. The taste of lemonade, for example, compounded of sweet, sour, cold and lemon odor, has the effect of a single characteristic sensation. It can be analyzed, but it ordinarily appears as a unit. This is true generally of blends; indeed, what we mean by blending is that, while the component sensations are still present and can be found by careful attention, they are not simply present together

but are compounded into a characteristic total. Each elementary sensation entering into the blend gives up some of its own quality, as, in the case of lemonade, neither the sweet nor the sour is quite so distinct and obtrusive as either would be if present alone. The same is true of the lemon odor, and it is true generally of the odor components that enter into the "tastes" of food. Were the odor components in these tastes as clear and distinct as they are when the same substance is smelled outside the mouth, we could not fail to notice that the "tastes" were largely composed of odor. The obtrusive thing about a blend is the total effect, not the elementary sensations that are blended.

THE SENSE OF SMELL

The great variety of odors long resisted every attempt at psychological analysis, largely because the olfactory end-organ is so secluded in position. You cannot apply stimuli to separate parts of it, as you can to the skin or tongue. But, recently, good progress has been made,¹ by assembling almost all possible odors, and becoming thoroughly acquainted with them, not as substances, but simply as odors, and noting their likenesses and differences. It seems possible now to state that there are six elementary odors, as follows:

1. Spicy, found in pepper, cloves, nutmeg, etc.
2. Flowery, found in heliotrope, etc.
3. Fruity, found in apple, orange oil, vinegar, etc.
4. Resinous, found in turpentine, pine needles, etc.
5. Foul, found in hydrogen sulphide, etc.
6. Scorched, found in tarry substances.

These being the elements, there are many compound odors. The odor of roasted coffee is a compound of resinous and scorched, peppermint a compound of fruity and spicy.

¹ By Henning.

Each elementary odor corresponds to a certain characteristic in the chemical constitution of the stimulus.

The sense of smell is extremely delicate, responding to very minute quantities of certain substances diffused in the air. It is extremely useful in warning us against bad air and bad food. It has also considerable esthetic value.

ORGANIC SENSATION

The term "organic sensation" is used to cover a variety of sensations from the internal organs, such as hunger, thirst, nausea, suffocation and less definite bodily sensations that color the emotional tone of any moment, contributing to "euphoria" and also to disagreeable states of mind. Hunger is a sensation aroused by the rubbing together of the stomach walls when the stomach, being ready for food, begins its churning movements. Careful studies of sensations from the internal organs reveal astonishingly little of sensation arising there, but there can be little doubt that the sensations just listed really arise where they seem to arise, in the interior of the trunk.

Little has been done to determine the elementary sensations in this field; probably the organic sensations that every one is familiar with are blends rather than elements.

THE SENSE OF SIGHT

Of the tremendous number and variety of visual sensations, the great majority are certainly compounds. Two sorts of compound sensation can be distinguished here: *blends*, similar to those of taste or smell, and *patterns*, which scarcely occur among sensations of taste and smell, though they are found, along with blends, in cutaneous sensation. Heat, compounded of warmth, cold and pain sensations, is an

excellent example of a blend, while the compound sensation aroused by touching the skin simultaneously with two points—or three points, or a ring or square—is to be classed as a pattern. In a pattern, the component parts are spread out in space or time (or in both at once), and for that reason are more easily attended to separately than the elements in a blend. Yet the pattern, like the blend, has the effect of a unit. A spatial pattern has a characteristic shape, and a temporal pattern a characteristic course or movement. A rhythm or a tune is a good example of a temporal pattern.

Visual sensations are spread out spatially, and thus fall into spatial patterns. They also are in constant change and motion, and so fall into temporal patterns, many of which are spatial as well. The visual sensation aroused, let us say in a young baby, by the light entering his eye from a human face, is a spatial pattern; the visual sensation aroused by some one's turning down the light is a pure temporal pattern; while the sensation from a person seen moving across the room is a pattern both spatial and temporal. Finding the elements of a visual pattern would mean finding the smallest possible bits of it, which would probably be the sensations due to the action of single rods and cones, just as the smallest bit of a cutaneous sensation would be due to the exciting of a single touch spot, warmth spot, cold spot or pain spot.

Analyzing a visual blend is quite a different job. Given the color pink, for example, let it be required to discover whether this is a simple sensation or a blend of two or more elementary sensations. Studying it intently, we see that it can be described as a whitish red, and if we are willing to accept this analysis as final, we conclude that pink is a blend of the elementary sensations of white and red. Of the thousands and thousands of distinguishable hues, shades

and tints, only a few are elements and the rest are color blends; and our main problem now is to identify the elements. Notice that we are not seeking for the physical elements of light, nor for the primary pigments of the painter's art, but for the elementary *sensations*. Our knowledge of physics and painting, indeed, is likely to lead us astray. Sensations are our responses to the physical stimulus, and the psychological question is, what fundamental responses we make to this class of stimuli.

Suppose, without knowing anything of pigments or of the physics of light, we got together a collection of bits of color of every shade and tint, in order to see what we could discover about visual sensations. Leaving aside the question of elements for the moment, we might first try to *classify* the bits of color. We could sort out a pile of reds, a pile of blues, a pile of browns, a pile of grays, etc., but the piles would shade off one into another. The salient fact about colors is the gradual transition from one to another. We can arrange them in *series* better than we can classify them. They can be serially arranged in three different ways, according to brightness or intensity, according to color-tone, and according to saturation.

The *intensity series runs from light to dark*. We can arrange such a series composed entirely of reds or blues or any other one color; or we can arrange the whole collection of bits of color into a single light-dark series. It is not always easy to decide whether a given shade of one color is lighter or darker than a given shade of a different color; but in a rough way, at least, every bit of whatever color would have its place in the single intensity series. An intensity series can, of course, be arranged in any other sense as well as in sight.

The *color-tone series* is best arranged from a collection consisting entirely of full or saturated colors. Start the

series with any color and put next to this the color that most resembles it in color-tone, i.e., in specific color quality; and so continue, adding always the color that most resembles the one preceding. If we started with red, the next in order might be either a yellowish red or a bluish red. If we took the yellowish red and placed it beside the red, then the

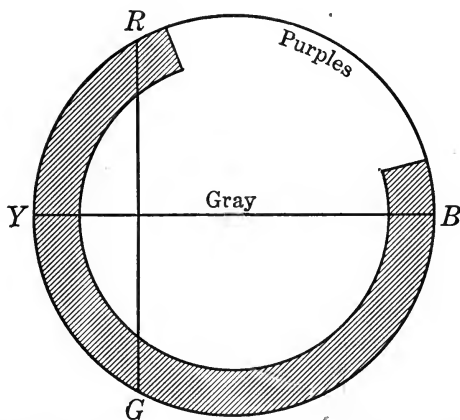

FIG. 33.—The color circle. *R*, *Y*, *G* and *B*, stand for the colors red, yellow, green and blue. The shaded portion corresponds to the spectrum or rainbow. Complementary colors (see later) lie diametrically opposite to each other on the circumference.

next in order would be a still more yellowish red, and the series would run on to yellow and then to greenish yellow, green, bluish green, blue, violet, purple, purplish red, and so back to red. The color-tone series returns upon itself. It is a circular series.

A *saturation series* runs from full-toned or saturated colors to pale or dull. Since we can certainly say of a pale blue that it is less saturated than a vivid red, etc., we could, theoretically, arrange our whole collection of bits of color in a single saturation series, but our judgment would be very uncertain at many points. The most significant saturation series confine themselves to a single color-tone,

and also, as far as possible, to a constant brightness, and extend from the most vivid color sensation obtainable with this color-tone and brightness, through a succession of less and less strongly colored sensations of the same tone and brightness, to a dead gray of the same brightness. Any such saturation series terminates in a neutral gray, which is light or dark to match the rest of the particular saturation series.

White, black and gray, which find no place in the color-tone series, give an intensity series of their own, running from white through light gray and darker and darker gray to black, and any gray in this series may be the zero point in a saturation series of any color-tone.

A three-dimensional diagram of the whole system of visual sensations can be built up in the following way. Taking all the colors of the same degree of brightness, we can arrange the most saturated, in the order of their color-tone, around the circumference of a circle, put a gray of the same brightness at the center of this circle, and then arrange a saturation series for each color-tone extending from the most saturated at the circumference to gray at the center. This would be a two-dimensional diagram for colors having the same brightness. For a greater brightness, we could arrange a similar circle and place it above the first, and for a smaller brightness, a similar circle and place it below the first, and we could thus build up a pile of circles, ranging from the greatest brightness at the top to the least at the bottom. But, as the colors all lose saturation when their brightness is much increased, and also when it is much decreased, we should make the circles smaller and smaller toward either the top or the bottom of the pile, so that our three-dimensional diagram would finally take the form of a double cone, with the most intense white, like that of sunlight, at the upper point, with dead black at the lower point,

and with the greatest diameter near the middle brightness, where the greatest saturations can be obtained. The axis of the double cone, extending from brightest white to dead black, would give the series of neutral grays. All the thou-

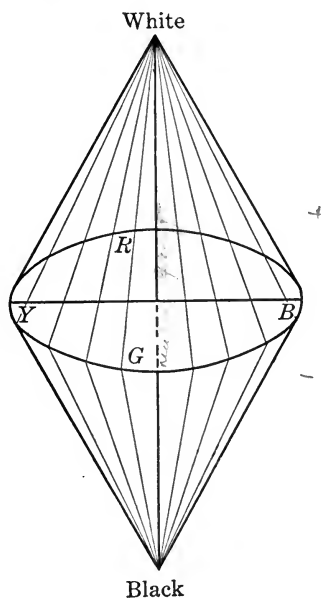

FIG. 34.—The color cone, described in the text. Instead of a cone, a four-sided pyramid is often used, so as to emphasize the four main colors, red, yellow, green and blue, which are then located at the corners of the base of the pyramid.

sands of distinguishable colors, shades and tints, would find places in this scheme.

SIMPLER FORMS OF THE COLOR SENSE

Not every one gets all these sensations. In *color-blindness*, the system is reduced to one or two dimensions, instead of three. There are two principal forms of color-blindness: total, very uncommon; and red-green blindness, fairly com-

mon. The totally color-blind individual sees only white, black, and the various shades of gray. His system of visual sensations is reduced to one dimension, corresponding to the axis of our double cone.

Red-green blindness, very uncommon in women, is present in three or four percent of men. It is not a disease, not curable, not corrected by training, and not associated with any other defect of the eye, or of the brain. It is simply a native peculiarity of the color sense. Careful study shows that the only color sensations of the red-green blind person are blue and yellow, along with white, black and the grays. His color circle reduces to a straight line with yellow at one end and blue at the other. Instead of the color circle, he has a double saturation series, reaching from saturated yellow through duller yellows to gray and thence through dull blues to saturated blue. What appears to the normal eye as red, orange or grass green appears to him as more or less unsaturated yellow; and what appears to the normal eye as greenish blue, violet and purple appears to him as more or less unsaturated blue. His color system can be represented in two dimensions, one for the double saturation series, yellow-gray-blue, and the other for the intensity series, white-gray-black.

Color-blindness, always interesting and not without some practical importance (since the confusions of the color-blind eye might lead to mistaking signals in navigation or railroading), takes on additional significance when we discover the curious fact that every one is color-blind—in certain parts of the retina. The outermost zone of the retina, corresponding to the margin of the field of view, is totally color-blind (or very nearly so), and an intermediate zone, between this and the central area of the retina that sees all the colors, is red-green blind, and delivers only blue and yellow sensations, along with white, black and gray. Take

a spot of yellow or blue and move it in from the side of the head into the margin of the field of view and then on towards the center. When it first appears in the margin, it simply appears gray, but when it has come inwards for a certain distance it changes to yellow. If a red or green spot is moved in similarly, it first appears gray, then takes on a faint tinge of yellow, and finally, as it approaches the center of the field of view, appears in its true color. The outer

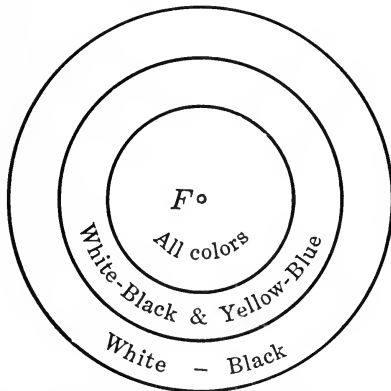

FIG. 35.—Color zones of the retina. F° is the fovea, or central area of clearest vision.

zone gets only black and white, the intermediate zone gets, in addition to these, yellow and blue, and the central area adds red and green (and with them all the colors).

Now as to the question of elements, let us see how far we can go, keeping still to the sensations, without any reference to the stimulus. If a collection of bits of color is presented to a class of students who have not previously studied this matter, with the request that each select those colors that seem to him elementary and not blends, there is practically unanimous agreement on three colors, red, yellow and blue; and there are some votes for green also, but almost none for orange, violet, purple, brown or any other colors,

except white and black. That white and black are elementary sensations is made clear by the case of total color-blindness, since in this condition there are no other visual sensations from which white and black could be compounded, and these two differ so completely from each other that it would be impossible to think of white as made up of black, or black of white. Gray, on the other hand, appears like a blend of black and white. In the same way, red-green blindness demonstrates the reality of yellow and blue as elementary sensations, since neither of them could be reduced to a blend of the other with white or black; and there are no other colors present in this form of color vision to serve as possible elements out of which yellow and blue might be compounded. That white, black, yellow and blue are elementary sensations is therefore clear from the study of visual sensations alone; and there are indications that red and green are also elements.

VISUAL SENSATIONS AS RELATED TO THE STIMULUS

Thus far, we have said nothing of the stimulus that arouses visual sensations. Light, the stimulus, is physically a wave motion, its vibrations succeeding each other at the rate of 500,000,000 vibrations, more or less, per second, and moving through space with a speed of 186,000 miles per second. The "wave-length", or distance from the crest of one wave to the crest of the next following, is measured in millionths of a millimeter.

The most important single step ever taken towards a knowledge of the physics of light, and incidentally towards a knowledge of visual sensations, was Newton's analysis of white light into the spectrum. He found that when white light is passed through a prism, it is broken up into all the colors of the rainbow or spectrum. Sunlight consists of a

mixture of waves of various lengths. At one end of the spectrum are the long waves (wave-length 760 millionths of a millimeter), at the other end are the short waves (wave-length 390), and in between are waves of every intermediate length, arranged in order from the longest to the shortest. The longest waves give the sensation of red, and the shortest that of violet, a slightly reddish blue.

Outside the limits of the visible spectrum, however, there are waves still longer and shorter, incapable of arousing the retina, though the very long waves, beyond the red, arouse the sensation of warmth from the skin, and the very short waves, beyond the violet, though arousing none of the senses, do effect the photographic plate. Newton distinguished seven colors in the visible spectrum, red, orange, yellow, green, blue, indigo and violet; but there is nothing specially scientific about this list, since physically there are not seven but an unlimited number of wave-lengths included in the spectrum, varying continuously from the longest at the red end to the shortest at the violet; while psychologically the number of distinguishable colors in the spectrum, though not unlimited, is at least much larger than seven. Between red and orange, for instance, there are quite a number of distinguishable orange-reds and reddish oranges.

If now we ask what differences in the stimulus give rise to the three kinds of difference in visual sensation that were spoken of previously, we find that color-tone depends on the wave-length of the light, brightness on the energy of the stimulus, i.e., on the amplitude of the vibration, and saturation on the mixture of long and short wave-lengths in a complex light-stimulus—the more mixture, the less saturation.

These are the general correspondences between the light stimulus and the visual sensation; but the whole relationship is much more complex. Brightness depends, not only on the energy of the stimulus, but also on wave-length. The

retina is tuned to waves of medium length, corresponding to the yellow, which arouse much brighter sensation than long or short waves of the same physical energy. Otherwise put, the sensitivity of the retina is greatest for medium wave-lengths, and decreases gradually towards the ends of the spectrum, ceasing altogether, as has been said, at wave-lengths of 760 at the red end and of 390 at the violet end.

Saturation, depending primarily on amount of mixture of different wave-lengths, depends also on the particular wave-lengths acting, and also on their amplitude. So, the red and blue of the spectrum are more saturated than the yellow and green; and very bright or very dim light, however homogeneous, gives a less saturated sensation than a stimulus of medium strength.

COLOR MIXING

Color-tone depends on the wave-length, as has been said, but this is far from the whole truth; the whole truth, indeed, is one of the most curious and significant facts about color vision. We have said that each color-tone is the response to a particular wave-length. But any color-tone can be got without its particular wave-length being present at all; all that is necessary is that wave-lengths centering about this particular one shall be present. A mixed light, consisting of two wave-lengths, the one longer and the other shorter than the particular wave which when acting alone gives a certain color-tone, will give that same color-tone. For example, the orange color resulting from the isolated action of a wave-length of 650 is given also by the combined action of wave-lengths of 600 and 700, in amounts suitably proportioned to each other.

A point of experimental technique: in *mixing colored lights* for the purpose of studying the resulting sensations, we do not mix painter's pigments, since the physical condi-

tions then would be far from simple, but we mix the lights themselves, by throwing them together either into the eye, or upon a white screen. We can also, on account of a certain lag or hang-over in the response of the retina, mix lights by rapidly alternating them, and get the same effect as if we had made them strike the retina simultaneously.

By mixing a red light with a yellow, in varying proportions, all the color-tones between red and yellow can be got—reddish orange, orange and yellowish orange. By mixing yellow and green lights, we get all the greenish yellow and yellowish green color-tones; and by mixing green and blue lights we get the bluish greens and greenish blues. Finally, by mixing blue and red lights, in varying proportions, we get violet, purple and purplish red. Purple has no place in the spectrum, since it is a sensation which cannot be aroused by the action of any single wave-length, but only by the mixture of long and short waves.

To get all the color-tones, then, we need not employ all the wave-lengths, but can get along with only four. In fact, we can get along with three. Red, green and blue will do the trick. Red and green lights, combined, would give the yellows; green and blue would give the greenish blues; and red and blue would give purple and violet.

The sensation of white results—to go back to Newton—from the combined action of all the wave-lengths. But the stimulus *need* not contain *all* the wave-lengths. Four are enough; the three just mentioned would be enough. More surprising still, two are enough, if chosen just right. Mix a pure yellow light with a pure blue, and you will find that you get the sensation of white—or gray, if the lights used are not strong.¹

¹When you mix blue and yellow *pigments*, each absorbs part of the wave-lengths of white light, and what is left after this double absorption may be predominantly green. This is absolutely different from the *addition* of blue to yellow light; addition gives white, not green.

Lights, or wave-lengths, which when acting together on the retina give the sensation of white or gray, are said to be *complementary*. Speaking somewhat loosely, we sometimes say that two *colors* are complementary when they mix to produce white. Strictly, the colors—or at least the color sensations—are not mixed; for when yellow and blue lights are mixed, the resulting sensation is by no means a mixture of blue and yellow sensations, but the sensation of white in which there is no trace of either blue or yellow. Mixing the *stimuli* which, acting separately, give two complementary colors, arouses the colorless sensation of white.

Blue and yellow, then, are complementary. Suppose we set out to find the complementary of red. Mixing red and yellow lights gives the color-tones intermediate between these two; mixing red and green still gives the intermediate color-tones, but the orange and yellow and yellowish green so get lack saturation, being whitish or grayish. Now mix red with bluish green, and this grayishness is accentuated, and if just the right wave-length of bluish green is used, no trace of orange or yellow or grass green is obtained, but white or gray. Red and bluish green are thus complementary. The complement of orange light is a greenish blue, and that of greenish yellow is violet. The typical green (grass green) has no single wave-length complementary to it, but it does give white when mixed with a compound of long and short waves, which compound by itself gives the sensation of purple; so that we may speak of green and purple as complementary.

WHAT ARE THE ELEMENTARY VISUAL SENSATIONS?

Returning now to the question of elementary sensations, which we laid aside till we had examined the relationship of the sensations to the stimulus, we need to be on our guard against physics, or at least against being so much impressed

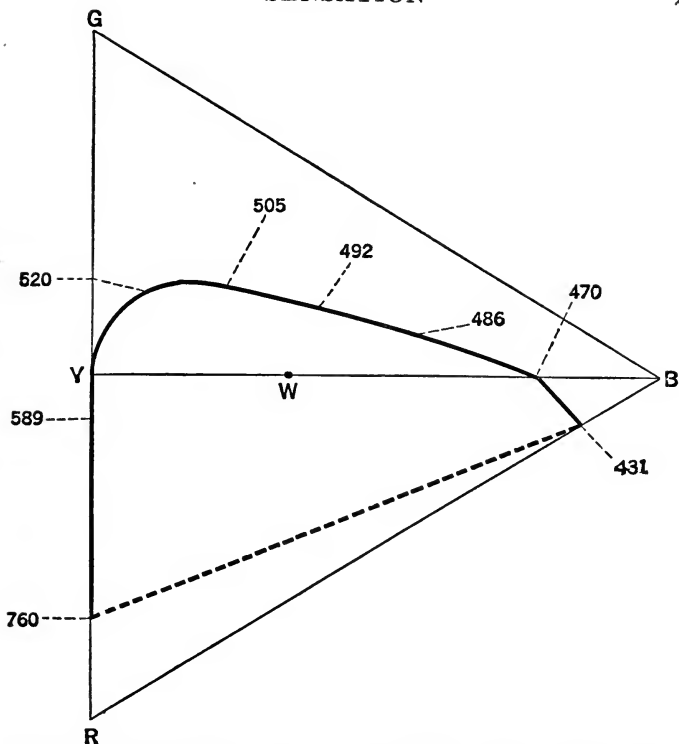

FIG. 36.—(After König.) The color triangle, a map of the laws of color mixture. The spectral colors are arranged in order along the heavy solid line, and the purples along the heavy dotted line. The numbers give the wave-lengths of different parts of the spectrum. Inside the heavy line are located the pale tints of each color, merging from every side into white, which is located at the point *W*.

Suppose equal amounts of two spectral colors are mixed: to find from the diagram the color of the mixture. Locate the two colors on the heavy line, draw a straight line between these two points, and the middle of this line gives the color-tone and saturation of the mixture. For example, mix red and yellow: then the resulting color is a saturated reddish yellow. Mix red (760) and green (505): the resulting yellow is non-saturated, since the straight line between these two points lies inside the figure. If the straight line joining two points passes through *W*, the colors located at the two points are complementary.

Spectral colors are themselves not completely saturated. The way to get color sensations of maximum saturation is first to stare at one color, so as to fatigue or adapt the eye for that color, and then to turn the eye upon the complementary color, which, under these conditions, appears fuller and richer than anything otherwise obtainable. The corners, *R*, *G*, and *B*, denote colors of maximum saturation, and the whole of the triangle outside of the heavy line is reserved for super-saturated color sensations.

with the physics of light as to forget that we are concerned with the *response* of the organism to physical light—a matter on which physics cannot speak the final word. Physics tells us of the stimulus, but we are concerned with the response. The facts of color-blindness and color mixing show very clearly that the response does not tally in all respects with the stimulus. Physics, then, is apt to confuse the student at this point and lead him astray. Much impressed with the physical discovery that *white* light is a mixture of all wave-lengths, he is ready to believe the sensation of white a mixed sensation. He says, “White is the sum of all the colors”, meaning that the sensation of white is compounded of the sensations of red, orange, yellow, green, blue and violet—which is simply not true. No one can pretend to get the sensations of red or blue in the sensation of white, and the fact of complementary colors shows that you cannot tell, from the sensation of white, whether the stimulus consists of yellow and blue, or red and bluish green, or red, green and blue, or all the wave-lengths, the response being the same to all these various combinations. Total color-blindness showed us, when we were discussing this matter before, that white was an elementary sensation, and nothing that has been said since changes that conclusion.

Consider *black*, too. Physics says, black is the absence of light; but this must not be twisted to mean that black is the absence of all visual sensation. Absence of visual sensation is simply nothing, and black is far from that. It is a sensation, as positive as any, and undoubtedly elementary.

From the point of view of physics, there is no reason for considering any one color more elementary than any other. Every wave-length is elementary; and if sensation tallied precisely with the stimulus, every spectral color-tone would be an element. But there are obvious objections to such a view, such as: (1) there are not nearly as many distinguish-

able color-tones as there are wave-lengths; (2) orange, having a single wave-length, certainly appears to be a blend as truly as purple, which has no single wave-length; and (3) we cannot get away from the fact of red-green blindness, in which there are only two color-tones, *yellow* and *blue*. In this form of color vision (which, we must remember, is normal in the intermediate zone of the retina), there are certainly not as many elementary responses as there are wave-lengths, but only one response to all the longer waves (the sensation of yellow), one response to all the shorter waves (the sensation of blue), one response to the combination of long and short waves (the sensation of white), and one response to the cessation of light (the sensation of black). These four are certainly elementary sensations, and there are probably only a few more.

There must be at least two more, because of the fact that two of the sure elements, yellow and blue, are complementary. For suppose we try to get along with one more, as *red*. Then red, blended with yellow, would give the intervening color-tones, namely, orange with reddish and yellowish orange; and red blended with blue would give violet and purple; but yellow and blue would only give white or gray, and there would be no way of getting green. We must admit *green* as another element. The particular red selected would be that of the red end of the spectrum, if we follow the general vote; and the green would probably be something very near grass green. We thus arrive at the conclusion that there are six elementary visual responses or sensations: white and black, yellow and blue, red and green.

It is a curious fact that some of these elementary sensations blend with each other, while some refuse to blend. White and black blend to gray, and either white or black or both together will blend with any of the four elementary colors or with any possible blend of these four. Brown, for

example, is a grayish orange, that is, a blend of white, black, red and yellow. Red blends with yellow, yellow with green, green with blue, and blue with red. But we cannot get yellow and blue to blend, nor red and green. When we try to get yellow and blue to blend, by combining their appropriate stimuli, both colors disappear, and we get simply the colorless sensation of white or gray. When we try to get red and green to blend, both of them disappear and we get the sensation of yellow.

THEORIES OF COLOR VISION

Of the most celebrated theories of color vision, the oldest, propounded by the physicists Young and Helmholtz, recognized only three elements, red, green and blue. Yellow they regarded as a blend of red and green, and white as a blend of all three elements. The unsatisfactory nature of this theory is obvious. White as a sensation is certainly not a blend of these three color sensations, but is, precisely, colorless; and no more is the yellow sensation a blend of red and green. Moreover, the theory cannot do justice either to total color-blindness, with its white and black but no colors, or to red-green blindness, with its yellow but no red or green.

The next prominent theory was that of the physiologist Hering. He did justice to white and black by accepting them as elements; and to yellow and blue likewise. The fact that yellow and blue would not blend he accounted for by supposing them to be antagonistic responses of the retina; when, therefore, the stimuli for both acted together on the retina, neither of the two antagonistic responses could occur, and what did occur was simply the more generic response of white. Proceeding along this line, he concluded that red and green were also antagonistic responses; but just here

he committed a wholly unnecessary error, in assuming that if red and green were antagonistic responses, the combination of their stimuli must give white, just as with yellow and blue. Accordingly, he was forced to select as his red and green elementary color-tones two that would be complementary; and this meant a purplish (i.e., bluish) red, and a bluish green, with the result that his "elementary" red and green appear to nearly every one as compounds and not elements. It would really have been just as easy for Hering to suppose that the red and green responses, antagonizing each other, left the sensation yellow; and then he could have selected that red and green which we have concluded above to have the best claim.

A third theory, propounded by the psychologist, Dr. Christine Ladd-Franklin, is based on keen criticism of the previous two, and seems to be harmonious with all the facts. She supposes that the color sense is now in the third stage of its evolution. In the first stage the only elements were white and black; the second stage added yellow and blue; and the third stage red and green. The outer zone of the retina is still in the first stage, and the intermediate zone in the second, only the central area having reached the third. In red-green blind individuals, the central area remains in the second stage, and in the totally color-blind the whole retina is still in the first stage.

In the first stage, one response, white, was made to light of whatever wave-length. In the second stage, this single response divided into two, one aroused by the long waves and the other by the short. The response to the long waves was the sensation of yellow, and that to the short waves the sensation of blue. In the third stage, the yellow response divided into one for the longest waves, corresponding to the red, and one for somewhat shorter waves, corresponding to the green. Now, when we try to get a blend of red and green

by combining red and green lights, we fail because the two responses simply unite and revert to the more primitive yellow response; and similarly when we try to get the yellow and blue responses together, they revert to the more primitive white response out of which they developed.

But, since no one can pretend to *see* yellow as a reddish green, nor white as a bluish yellow, it is clear that the just-spoken-of union of the red and green responses, and of the

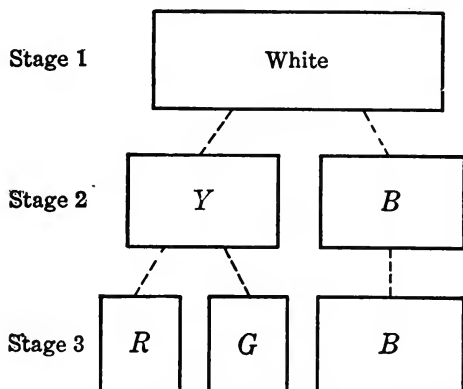

FIG. 37.—The Ladd-Franklin theory of the evolution of the color sense.

yellow and blue responses, must take place *below the level of conscious sensation*. These unions probably take place within the retina itself. Probably they are purely chemical unions.

The *very first* response of a rod or cone to light is probably a purely chemical reaction. Dr. Ladd-Franklin, carrying out her theory, supposes that a light-sensitive "mother substance" in the rods and cones is decomposed by the action of light, and gives off cleavage products which arouse the vital activity of the rods and cones, and thus start nerve currents coursing towards the brain.

In the "first stage", she supposes, a *single big* cleavage product, which we may call W, is split off by the action of

light upon the mother substance, and the vital response to W is the sensation of white.

In the second stage, the mother substance is capable of giving off *two* smaller cleavage products, Y and B. Y is split off by the long waves of light, and B by the short waves, and the vital response to Y is the sensation of yellow, that to B the sensation of blue. But suppose that, chemically, $Y + B = W$: then, if Y and B are both split off at the same

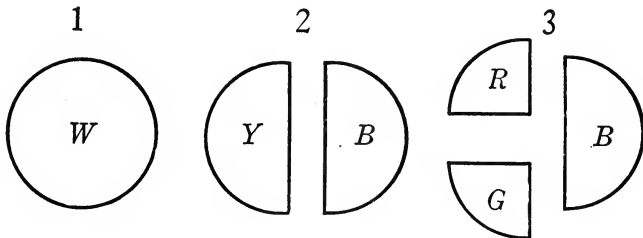

FIG. 38.—The cleavage products, in the three stages of the color sense. The “mother substance” is not represented in the diagram, but only the cleavage products which, according to the Ladd-Franklin theory, are the direct stimuli for the color sensations.

time in the same cone, they immediately unite into W, and the resulting sensation is white, and neither yellow nor blue.

Similarly, in the third stage, the mother substance is capable of giving off *three* cleavage products, R, G and B; and there are three corresponding vital responses, the sensations of red, green and blue. But, chemically, $R + G = Y$; and therefore, if R and G are split off at the same time, they unite chemically into Y and give the sensation of yellow. If R, G and B are all split off at the same time, they unite chemically as follows: $R + G = Y$, and $Y + B = W$; and therefore the resulting sensation is that of white.

This theory of cleavage products is in good general agreement with chemical principles, and it does justice to all the facts of color vision, as detailed in the preceding pages. It should be added that “for black, the theory supposes that,

in the interest of a continuous field of view, objects which reflect no light at all upon the retina have correlated with them a definite non-light sensation—that of black.”¹

ADAPTATION

Sensory adaptation is a change that occurs in other senses also, but it is so much more important in the sense of sight than elsewhere that it may best be considered here. The stimulus continues, the sensation ceases or diminishes—that is the most striking form of sensory adaptation. Continued action of the same stimulus puts the sense into such a condition that it responds differently from at first, and usually more weakly. It is much like fatigue, but it often is more positive and beneficial than fatigue.

The sense of smell is very subject to adaptation. On first entering a room you clearly sense an odor that you can no longer get after staying there for some time. This adaptation to one odor does not prevent your sensing quite different odors. Taste shows less adaptation than smell, but all are familiar with the decline in sweet sensation that comes with continued eating of sweets.

All of the cutaneous senses except that for pain are much subject to adaptation. Continued steady pressure gives a sensation that declines rapidly and after a time ceases altogether. The temperature sense is usually adapted to the temperature of the skin, which therefore feels neither warm nor cool. If the temperature of the skin is raised from its usual level of about 70° Fahrenheit to 80 or 85, this temperature at first gives the sensation of warmth, but after a time it gives no temperature sensation at all; the warmth sense has become adapted to the temperature of 80 degrees; and now a temperature of 70 will give the sensation of cool.

¹ Quotation from Dr. Ladd-Franklin.

Hold one hand in water at 80 and the other in water at 55, and when both have become adapted to these respective temperatures, plunge them together into water at 70; and you will find this last to feel cool to the warm-adapted hand and warm to the cool-adapted. There are limits to this power of adaptation.

The muscle sense seems to become adapted to any fixed position of a limb, so that, after the limb has remained motionless for some time, you cannot tell in what position it is; to find out, you have only to move it the least bit, which will excite both the muscle sense and the cutaneous pressure sense. The sense of head rotation is adaptable, in that a rotation which is keenly sensed at the start ceases to be felt as it continues; but here it is not the sense cells that become adapted, but the back flow that ceases, as will soon be explained.

To come now to the sense of sight, we have *light adaptation*, *dark adaptation*, and *color adaptation*. Go into a dark room, and at first all seems black, but by degrees—provided there is a little light filtering into the room—you begin to see, for your retina is becoming dark-adapted. Now go out into a bright place, and at first you are “blinded”, but you quickly “get used” to the bright illumination and see objects much more distinctly than at first; for your eye has now become light-adapted. Remain for some time in a room illuminated by a colored light (as the yellowish light of most artificial illuminants), and by degrees the color sensation bleaches out so that the light appears nearly white.

Dark adaptation is equivalent to sensitizing the retina for faint light. Photographic plates can be made of more or less sensitiveness for use with different illuminations; but the retina automatically alters its sensitivity to fit the illumination to which it is exposed.

ROD AND CONE VISION

You will notice, in the dark room, that while you see light and shade and the forms of objects, you do not see colors. The same is true out of doors at night. In other words, the kind of vision that we have when the eye is dark-adapted is totally color-blind. Another significant fact is that the fovea is of little use in very dim light. These facts are taken to mean that dim-light vision, or *twilight vision* as it is sometimes called, is rod vision and not cone vision; or, in other words, that the rods and not the cones have the great sensitiveness to faint light in the dark-adapted eye. The cones perhaps become somewhat dark-adapted, but the rods far outstrip them in this direction. The fovea has no rods and hence is of little use in very faint light. The rods have no differential responsiveness to different wave-lengths, remaining still in the "first stage" in the development of color vision, and consequently no colors are seen in faint light.

Rod vision differs then from cone vision in having only one response to every wave-length, and in adapting itself to much fainter light. No doubt, also, it is the rods that give to peripheral vision its great sensitivity to moving objects.

AFTER-IMAGES

After-images, which might better be called after-sensations, occur in other senses than sight, but nowhere else with such definiteness. The main fact here is that the response outlasts the stimulus. This is true of a muscle, and it is true of a sense organ. It takes a little time to get the muscle, or the sense organ, started, and, once it is in action, it takes a little time for it to stop. If you direct your eyes towards the lamp, holding your hand or a book in front of them as a screen, remove the screen for an in-

stant and then replace it, you will continue for a short time to see the light after the external stimulus has been cut off. This "positive after-image" is like the main sensation, only weaker. There is also a "negative after-image", best got by looking steadily at a black-and-white or colored figure for as long as fifteen or twenty seconds, and then directing the eyes upon a medium gray background. After a moment a sensation develops in which black takes the place

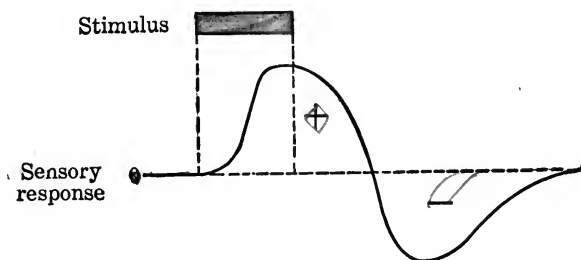

FIG. 39.—The visual response outlasts the stimulus. The progress of time is supposed to be from left to right in the diagram. After the stimulus ceases, the sensation persists for a time, at first as a positive after-image, and then as a negative after-image, a sort of back swing.

of white and white of black, while for each color in the original sensation the complementary color now appears. This phenomenon of the negative after-image is the same as that of color adaptation. Exposing the retina for some time to light of a certain color adapts the retina to that color, bleaches that color sensation, and, as it were, subtracts that color (or some of it) from the gray at which the eyes are then directed; and gray (or white) minus a color gives the complementary color. /

CONTRAST

Contrast is still another effect that occurs in other senses, but most strikingly in vision. There is considerable in common between the negative after-image and contrast; indeed,

the negative after-image effect is also called "successive contrast". After looking at a bright surface, one of medium brightness appears dark, while this same medium brightness would seem bright after looking at a dark surface. This is evidently adaptation again, and is exactly parallel to what was found in regard to the temperature sense. After looking at any color steadily, the complementary color appears more saturated than usual; in fact, this is the way to secure the maximum of saturation in color sensation. These are examples of "successive contrast".

"Simultaneous contrast" is something new, not covered by adaptation, but gives the same effects as successive contrast. If you take two pieces of the same gray paper, and place one on a black background and the other on white, you will find the piece on the black ground to look much brighter than the piece on the white ground. Spots of gray on colored backgrounds are tinged with the complementary colors. The contrast effect is most marked at the margin adjoining the background, and grows less away from this margin. Any two adjacent surfaces produce contrast effects in each other, though we usually do not notice them any more than we usually notice the after-images that occur many times in the course of the day.

THE SENSE OF HEARING

Sound, like light, is physically a wave motion, though the sound vibrations are very different from those of light. They travel 1,100 feet a second, instead of 186,000 miles a second. Their wave-length is measured in feet instead of in millionths of a millimeter, and their vibration frequencies are counted in tens, hundreds and thousands per second, instead of in millions of millions. But sound waves vary among themselves in the same three ways that we

noticed in light waves: in amplitude, in wave-length (or vibration rate), and in degree of mixture of different wave-lengths.

Difference of amplitude (or energy) of sound waves produces difference of loudness in auditory sensation, which thus corresponds to brightness in visual sensation. Sounds can be arranged in order of loudness, as visual sensations can be arranged in order of brightness, both being examples of intensity series such as can be arranged in any kind of sensation.

Difference of wave-length of sound waves produces difference in the pitch of auditory sensation, which thus corresponds to color in visual sensation. Pitch ranges from the lowest notes, produced by the longest audible waves, to the highest, produced by the shortest audible waves. It is customary, in the case of sound waves, to speak of vibration rate instead of wave-length, the two quantities being inversely proportional to each other (in the same conducting medium). The lowest audible sound is one of about sixteen vibrations per second, and the highest one of about 30,000 per second, while the waves to which the ear is most sensitive have a vibration rate of about 1,000 to 4,000 per second. The ear begins to lose sensitiveness as early as the age of thirty, and this loss is most noticeable at the upper limit, which declines slowly from this age on.

Middle C of the piano (or any instrument) has a vibration rate of about 260. Go up an octave from this and you double the number of vibrations per second; go down an octave and you halve the number of vibrations. Of any two notes that are an octave apart, the upper has twice the vibration rate of the lower. The whole range of audible notes, from 16 to 30,000 vibrations, thus amounts to about eleven octaves, of which music employs about eight octaves, finding little use for the upper and lower extremes of the

pitch series. The smallest step on the piano, called the "semitone", is one-twelfth of an octave; but it must not be supposed that this is the smallest difference that can be perceived. A large proportion of people can observe a difference of four vibrations, and keen ears a difference of less than one vibration; whereas the semitone, at middle C, is a step of about sixteen vibrations.

Mixture of different wave-lengths, which in light causes difference of saturation, may be said in sound to cause difference of purity. A "pure tone" is the sensation aroused by a stimulus consisting wholly of waves of the same length. Such a stimulus is almost unobtainable, because every sounding body gives off, along with its fundamental waves, other waves shorter than the fundamental and arousing tone sensations of higher pitch, called "overtones". A piano string which, vibrating as a whole, gives 260 vibrations per second (middle C), also vibrates at the same time in halves, thus giving 520 vibrations per second; in thirds, giving 780 per second; and in other smaller segments. The whole stimulus given off by middle C of the piano is thus a compound of fundamental and overtones; and the sensation aroused by this complex stimulus is not a "pure tone" but a blend of fundamental tone and overtones. By careful attention and training, we can "hear out" the separate overtones from the total blend; but ordinarily we take the blend as a unit (just as we take the taste of lemonade as a unit), and hear it simply as middle C of a particular quality, namely the piano quality. Another instrument will give a somewhat different combination of overtones in the stimulus, and that means a different quality of tone in our sensation. We do not ordinarily analyze these complex blends, but we distinguish one from another perfectly well, and thus can tell whether a piano or a cornet is playing. The difference between different instruments, which we have spoken of as a

difference in quality or purity of tone, is technically known as *timbre*; and the timbre of an instrument depends on the admixture of shorter waves with the fundamental vibration which gives the main pitch of a note.

Akin to the timbre of an instrument is the *vowel* produced by the human mouth in any particular position. Each vowel appears to consist, physically, of certain high notes produced by the resonance of the mouth cavity. In the position for "ah", the cavity gives a certain tone; in the position for "ee" it gives a higher tone. Meanwhile, the pitch of the voice, determined by the vibration of the vocal cords, may remain the same or vary in any way. The vowel tones differ from overtones in remaining the same without regard to the pitch of the fundamental tone that is being sung or spoken, whereas overtones move up or down along with their fundamental. The vowels, as auditory sensations, are excellent examples of blends, in that, though compounds, they usually remain unanalyzed and are taken simply as units. What has been said of the vowels applies also to the semi-vowels and continuing consonants, such as l, m, n, r, f, th, s and sh.

Other consonants are to be classed with the *noises*. Like a vowel, and like the timbre of an instrument, a noise is a blend of simple tones; but the fundamental tone in a noise-blend is not so preponderant as to give a clear pitch to the total sound, while the other tones present are often too brief or too unsteady to give a tonal effect.

COMPARISON OF SIGHT AND HEARING

The two senses of sight and hearing have many curious differences, and one of the most curious appears in mixing different wave-lengths. Compare the effect of throwing two colored lights together into the eye with the effect of throw-

ing two notes together into the ear. Two notes sounded together may give either a harmonious blend or a discord; now the discord is peculiar to the auditory realm; mixed colors never clash, though colors seen side by side may do so to a certain extent. A discord of tones is characterized by imperfect blending (something unknown in color mixing), and by roughness due to the presence of "beats" (another thing unknown in the sense of sight). Beats are caused by the interference between sound waves of slightly different vibration rate. If you tune two whistles one vibration apart and sound them together, you get a tone that swells once a second; tune them ten vibrations apart and you get ten swellings or beats per second, and the effect is rough and disagreeable.

Aside from discord, a tone blend is really not such a different sort of thing from a color blend. A chord, in which the component notes blend while they can still, by attention and training, be "heard out of the chord", is quite analogous with such color blends as orange, purple or bluish green. At the same time, there is a curious difference here. By analogy with color mixing, you would expect two notes, as C and E, when combined, to give the same sensation as the single intermediate note D. Nothing of the kind! Were it so, music would be very different from what it is, if indeed it were possible at all. But the real difference between the two senses at this point is better expressed by saying that D does not give the effect of a combination of C and E, or, in general, that no one note ever gives the effect of a combination or blend of notes higher and lower than itself. Homogeneous orange light gives the sensation of a blend of red and yellow; but there is nothing like this in the auditory sphere. In light, some wave-lengths give the effect of simple colors, as red and yellow; and other wave-lengths the effect of blends, as greenish yellow or bluish

green; but in sound, every wave-length gives a tone which seems just as elementary as any other.

There is nothing in auditory sensation to correspond to white, no simple sensation resulting from the combined action of all wave-lengths. Such a combination gives noise, but nothing that seems particularly simple. There is nothing auditory to correspond with black, for silence seems to be a genuine absence of sensation. There are no complementary tones like the complementary colors, no tones that destroy each other instead of blending. In a word, auditory sensation tallies with its stimulus much more closely than visual sensation does with its; and the main secret of this advantage of the sense of hearing is that it has a much larger number of elementary responses. Against the six elementary visual sensations are to be set auditory elements to the number of hundreds or thousands. From the fact that every distinguishable pitch gives a tone which seems as simple and unblended as any other, the conclusion would seem to be that each was an element; and this would mean thousands of elements. On the other hand, the fact that tones close together in pitch sound almost alike may mean that they have elements in common and are thus themselves compounds; but still there would undoubtedly be hundreds of elements.

Both sight and hearing are served by great armies of sense cells, but the two armies are organized on very different principles. In the retina, the sense cells are spread out in such a way that each is affected by light from one particular direction; and thus the retina gives excellent space information. But each retinal cell is affected by any light that happens to come from its particular direction. Every cone, in the central area of the retina, makes all the elementary visual responses and gives all the possible color sensations; so it is not strange that the number of visual ele-

ments is small. On the other hand, the ear, having no sound lens, has no way of keeping separate the sounds from different directions (and accordingly gives only meager indications of the direction of sound); but its sense cells are so spread out as to be affected, some by sound of one wave-length, others by other wave-lengths. The different tones do not all come from the same sense cells. Some of the auditory cells give the low tones, others the medium tones, still others the high tones; and since there are thousands of cells, there may be thousands of elementary responses.

THEORY OF HEARING

The most famous theory of the action of the inner ear is the "piano theory" of Helmholtz. The foundation of the theory is the fact that the sense cells of the cochlea stand on the "basilar membrane", a long, narrow membrane stretched between bony attachments at either side, and composed partly of fibers running crosswise, very much as the strings of a piano or harp are stretched between two side bars. If you imagine the strings of a piano to be the warp of a fabric and interwoven with crossing fibers, you have a fair idea of the structure of the basilar membrane, except for the fact that the "strings" of the basilar membrane do not differ in length anywhere like as much as the strings of the piano must differ in order to produce the whole range of notes. Now, a piano string can be thrown into "sympathetic vibration", as when you put on the "loud pedal" (remove the dampers from the strings) and then sing a note into the piano. You will find that the string of the pitch sung has been thrown into vibration by the action of the sound waves sung against it.

Now suppose the strings of the basilar membrane to be tuned to notes of all different pitches, within the range of

audible vibrations: then each string would be thrown into sympathetic vibration whenever waves of its own vibration rate reached it by way of the outer and middle ear; and the sense cells standing over the vibrating fibers would be shaken and excited. The theory is very attractive because it would account so nicely for the great number of elementary tone sensations (there are over 20,000 fibers or strings in the basilar membrane), as well as for various other facts of hearing—if we could only believe that the basilar membrane did vibrate in this simple manner, fiber by fiber. But (1) the fabric into which the strings of the membrane are woven would prevent their vibrating as freely and independently as the theory requires; (2) the strings do not differ in length a hundredth part of what they would need to differ in order to be tuned to all notes from the lowest to the highest, and there is no sign of differences in stretch or in loading of the strings to make up for their lack of difference in length; and (3) a little model of the basilar membrane, exposed to sound waves, is seen to be thrown into vibration, indeed, and into different forms of vibration for waves of different length, but not by any means into the simple sort of vibration demanded by the piano theory. This theory is accordingly too simple, but it probably points the way towards some truer, more complex, conception.

The fact that there are many elementary sensations of hearing is the chief reason why the art of tones is so much more elaborate than the art of color; for while painting might dispute with music as to which were the more highly developed art, painting depends on form as well as color, and there is no art of pure color at all comparable with music, which makes use simply of tones (and noises) with their combinations and sequences.

SENSES OF BODILY MOVEMENT

It is a remarkable fact that some parts of the inner ear are not connected with hearing at all, but with quite another sense, the existence of which was formerly unsuspected. The two groups of sense cells in the vestibule—the otolith organs—were formerly supposed to be the sense organ for noise; but noise now appears to be a compound of tones, and its organ, therefore, the cochlea. The *semicircular canals*, from their arrangement in three planes at right angles to each other, were once supposed to analyze the sound according to the direction from which it came; but no one could give anything but the vaguest idea of how they might do this, and besides the ear is now known to give practically no information regarding the direction of sound, except the one fact whether it comes from the right or left, which is given by the difference in the stimulation received by the two ears, and not by anything that exists in either ear taken alone.

The *semicircular canals* have been much studied by the physiologists. They found that injury to these structures brought lack of equilibrium and inability to walk, swim or fly in a straight course. If, for example, the horizontal canal in the left ear is destroyed, the animal continually deviates to the left as he advances, and so is forced into a "circus movement". They found that the compensatory movements normally made in reaction to a movement impressed on the animal from without were no longer made when the canals were destroyed. They found that something very much like these compensatory movements could be elicited by direct stimulation of the end-organs in the canals or of the sensory nerves leading from them. And they found that little currents of the liquid filling the canals acted as a stimulus to these end-organs and so aroused the

compensatory movements. They were thus led to accept a view that was originally suggested by the position of the canals in space.

Each "semicircular" canal, itself considerably more than a semicircular tube, opens into the vestibule at each end and thus amounts to a complete circle. Therefore rotating the

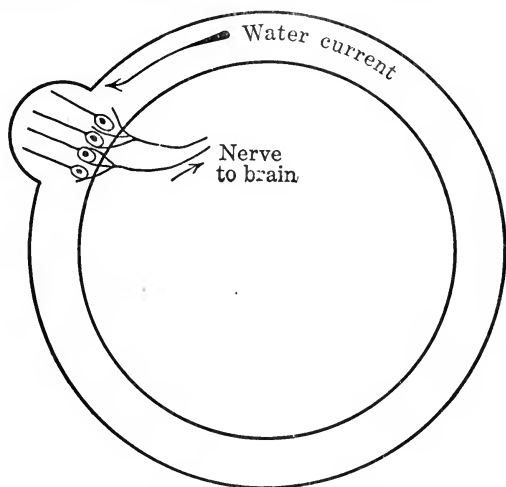

FIG. 40.—How the sense cells in a semicircular canal are stimulated by a water current. This current is itself an inertia back-flow, resulting from a turning of the head in the opposite direction.

head must, by inertia, produce a back flow of the fluid contents of the canal, and this current, by bending the hairs of the sense cells in the canal, would stimulate them and give a sensation of rotation, or at least a sensory nerve impulse excited by the head rotation.

When a human subject is placed, blindfolded, in a chair that can be rotated without sound or jar, it is found that he can easily tell whenever you start to turn him in either direction. If you keep on turning him at a constant speed, he soon ceases to sense the movement, but if then you stop him, he says you are starting to turn him in the opposite

direction. He senses the beginning of the rotary movement because this causes the back flow through his canals; he ceases to sense the uniform movement because friction of the liquid in the slender canal soon abolishes the back flow by causing the liquid to move with the canal; and he senses the stopping of this movement because the liquid, again by inertia, continues to move in the direction it had been moving just before when it was keeping pace with the canal. Thus we see that there are conscious sensations of rotation from the canals, and that these give information of the starting or stopping of a rotation, though not of its steady continuance. Excessive stimulation of the canals gives the sensation of dizziness.

The otolith organs in the vestibule are probably excited, not by rotary movements, but by sudden startings and stoppings of rectilinear motion, as in an elevator; and also by the pull of gravity when the head is held in any position. They give information regarding the position and rectilinear movements of the head, as the canals do of rotary head movements. Both are important in maintaining equilibrium and motor efficiency.

The muscle sense is another sense of bodily movement; it was the "sixth sense", so bitterly fought in the middle of the last century by those who maintained that the five senses that were enough for our fathers ought to be enough for us, too. The question was whether the sense of touch did not account for all sensations of bodily movement. It was shown that there must be something besides the skin sense, because weights were better distinguished when "hefted" in the hand than when simply laid in the motionless palm; and it was shown that loss of skin sensation in an arm or leg interfered much less with the coördinated movements of the limb than did the loss of all the sensory nerves to the limb. Later, the crucial fact was established

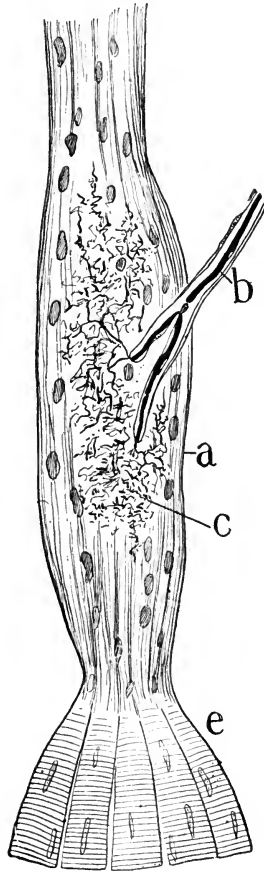

FIG. 41.—(From Cajal.) A “tendon spindle,” very similar to the muscle spindle spoken of in the text, but found at the tendinous end of a muscle instead of embedded in the muscle substance itself. “a” indicates the tendon, and “e” the muscle fibers; “b” is a sensory axon, and “c” its end-brush about the spindle. Let the tendon become taut in muscular contraction, and the fine branches of the sensory axon will be squeezed and so stimulated.

that sense organs (the “muscle spindles”) existed in the muscles and were connected with sensory nerve fibers; and that other sense organs existed in the tendons and about

the joints. This sense accordingly might better be called the "muscle, tendon and joint sense", but the shorter term, "muscle sense", bids fair to stick. The Greek derivative, "kinesthesia", meaning "sense of movement", is sometimes used as an equivalent; and the corresponding adjective, "kinesthetic", is common.

The muscle sense informs us of movements of the joints and of positions of the limbs, as well as of resistance encountered by any movement. Muscular fatigue and soreness are sensed through the same general system of sense organs. This sense is very important in the control of movement, both reflex and voluntary movement. Without it, a person lacks information of where a limb is to start with, and naturally cannot know what movement to make; or, if a movement is in process of being executed, he has no information as to how far the movement has progressed and cannot tell when to stop it. Thus it is less strange than it first appears to learn that "locomotor ataxia", a disease which shows itself in poor control of movement, is primarily a disease affecting not the motor nerves but the sensory nerves that take care of the muscle sense.

EXERCISES

1. Outline the chapter, rearranging the material somewhat, so as to state, under each sense, (a) what sense cells, if any, are present in the sense organ, (b) what accessory apparatus is present in the sense organ, (c) what stimuli arouse the sense, (d) what are the elementary responses of the sense, (e) peculiar blends occurring within the sense or between this sense and another, (f) what can be said regarding adaptation of the sense, and (g) what can be said regarding after-images of the sense.

2. Classify the senses according as they respond to stimuli (a) internal to the body, (b) directly affecting the surface of the body, (c) coming from a distance.

3. What distinctive *uses* are made of each sense?

4. Explore a small portion of the skin, as on the back of the hand, for cold spots, and for pain spots.

5. Try to analyze the smooth sensation obtained by laying the finger tip on a sheet of paper, and the rough sensation obtained by laying the finger tip on the surface of a brush, and to describe the difference in terms of the elementary skin sensations.

6. Is the pain sense a highly developed sense, to judge from its sense organ? Is it highly specialized? highly sensitive? How does its peculiarity in these respects fit it for its use?

7. Separation of taste and smell. Compare the taste of foods when the nostrils are held closed with the taste of the same food when the nostrils are opened.

8. Make a complete analysis of the sensations obtained from chocolate ice cream in the mouth.

9. Peripheral vision. (a) Color sense. While your eyes are looking rigidly straight ahead, take a bit of color in the hand and bring it slowly in from the side, noticing what color sensation you get from it when it can first be seen at all, and what changes in color appear as it moves from the extreme periphery to the center of the field of view. (b) Form sense. Use printed letters in the same way, noticing how far out they can be read. (c) Sense of motion. Notice how far out a little movement of the finger can be seen. Sum up what you have learned of the differences between central and peripheral vision. What is the use of peripheral vision?

10. Light and dark adaptation. Go from a dimly lighted place into bright sunlight, and immediately try for an instant to read with the sun shining directly upon the page. Remaining in the sunlight,

repeat the attempt every 10 seconds, and notice how long it takes for the eye to become adapted to the bright light. Having become light-adapted, go back into a dimly lighted room, and see whether dark-adaptation takes more or less time than light-adaptation.

11. Color-adaptation. Look steadily at a colored surface, and notice whether the color fades as the exposure continues. Try looking at the color with one eye only, and after a minute look at the color with each eye separately, and notice whether the saturation appears the same to the eye that has been exposed to the color, and to the eye that has been shielded.

12. Negative after-images. Look steadily for half a minute at a black cross upon a white surface, and then turn the eyes upon a plain gray surface, and describe what you see. (b) Look steadily for half a minute at a colored spot upon a white or gray background, and then turn the eyes upon a gray background, and note the color of the after-image of the spot. Repeat with a different color, and try to reach a general statement as to the color of the negative after-image.

13. Positive visual after-images. Look in the direction of a bright light, such as an electric light, holding the hand as a screen before the eyes, so that you do not see the light. Withdraw the hand for a second, exposing the eyes to the light, and immediately screen the eyes again, and notice whether the sensation of the light outlasts the stimulus.

14. Tactile after-images. Touch the skin lightly for an instant, and notice whether the sensation ends as soon as the stimulus is removed. If there is any after-image, is it positive or negative?

15. Tactile adaptation. Support two fingers on the edge of a table, and lay on them a match or some other light object. Let this stimulus remain there, motionless, and notice whether the tactile sensation remains steady or dies out. What is the effect of making slight movements of the fingers, and so causing the stimulus to affect fresh parts of the skin?

16. Temperature sense adaptation. Have three bowls of water, one quite warm, one cold, one medium. After holding one hand in the warm water and the other in the cold, transfer both simultaneously to the medium water and compare the temperature sensations got by each hand from this water. State the result in terms of adaptation.

17. Overtones. These can be quite easily heard in the sound of a large bell. What use does the sense of hearing make of overtones?

REFERENCES

For a somewhat fuller discussion of the topic of sensation, see Warren's *Human Psychology*, 1919, pp. 151-214; and for a much fuller discussion, see Titchener's *Textbook of Psychology*, 1909, pp. 46-224.

For a really thorough consideration of the facts and theories of color vision, see J. Herbert Parsons, *An Introduction to the Study of Colour Vision*, 1915.

For a more complete statement of the Ladd-Franklin theory, see the article on "Vision", in Baldwin's *Dictionary of Philosophy and Psychology*, 1902.

For a recent study that has revolutionized the psychology of the sense of smell, see *Der Geruch*, by Hans Henning, 1916, or a review of the same by Professor Gamble in the *American Journal of Psychology*, 1921, Vol. 32, pp. 290-295.

For an extensive discussion of the "Psychology of Sound", see the book with this title by Henry J. Watt, 1917.

For a full account of taste, see Hollingworth and Poffenberger's *Sense of Taste*, 1917.

CHAPTER XI

ATTENTION

HOW WE ATTEND, TO WHAT, AND WITH WHAT RESULTS

“Attention!” shouts the officer as a preliminary to some more specific command, and the athletic starter calls out “Ready!” for the same purpose. Both commands are designed to put the hearer in an attitude of readiness for what is coming next. They put a stop to miscellaneous doings and clear the way for the specific reaction that is next to be called for. They nullify the effect of miscellaneous stimuli that are always competing for the hearer’s attention, and make him responsive only to stimuli coming from the officer. They make the hearer clearly conscious of the officer. They arouse in the hearer a condition of keen alertness that cannot be maintained for more than a few seconds unless some further command comes from the officer. In all these ways “attention” in the military sense, or “readiness” in the athletic sense, affords a good picture of the psychology of attention. Attention is preparatory, selective, mobile, highly conscious. To attend to a thing is to be keenly conscious of that thing, it is to respond to that thing and disregard other things, and it is to expect something more from that thing.

Attention is, in a word, exploratory. To attend is to explore, or to start to explore. Primitive attention amounts to the same as the instinct of exploration. Its natural stimulus is anything novel or sudden, its “emotional state” is curiosity or expectancy, and its instinctive reaction consists

of exploratory movements. Its inherent impulse is to explore, examine, or await.

Attention belongs fundamentally among the native forms of behavior. The child does not have to learn to attend, though he must learn to attend to many things that do not naturally get his attention. Some stimuli naturally attract attention, and others attract attention only because of previous experience and training. In considering the whole subject of attention, then, we shall in part be dealing with native responses, and in part with responses that are acquired. But the great laws of attention, which will come to light in the course of the chapter, are at the same time general laws of reaction, and belong under the head of native characteristics.

THE STIMULUS, OR WHAT ATTRACTS ATTENTION

We can attend to anything whatever, but are more likely to attend to some things than to others. As stimuli for attention, some objects are much more effective than others, and the question is, in what way one object has the advantage over another. There are several ways, several "factors of advantage", we may call them.

Change is the greatest factor of advantage. A steady noise ceases after a while to be noticed, but let it change in any respect and immediately it arrests attention. The ticking of the clock is a good example: as long as it keeps uniformly on, it is unnoticed, but if it should suddenly beat faster or louder or in a different key, or even if it should stop altogether, it would "wake us up" with a start. The change in the stimulus must not be too gradual if it is to be effective, it must have a certain degree of suddenness. It may be a change in intensity, a becoming suddenly stronger or weaker; or it may be change in quality, as in tone, or

color, or odor: or it may be a change in position, a movement in space. When one who is holding our arm gives it a sudden squeeze to attract our attention, that is a change of intensity; when we step from the bank into the water, the sudden change from warmth to cold, that gets our attention without fail, is a change of quality; and something crawling on the skin attracts attention by virtue of its motion. Anything moving in the field of view is also an unfailing stimulus to attention.

Strength, or high intensity of a stimulus, is another important factor of advantage. Other things being equal, a strong stimulus will attract attention before a weak one. A loud noise has the advantage over a low murmur, and a bright flash of light over a faint twinkle.

In the case of visible objects, *size* has about the same effect as intensity. The large features of the landscape are noticed before the little details. The advertiser uses large type, and pays for big space in the newspaper, in the effort to attract the attention of the reader.¹

Another similar factor is *repetition*. Cover a billboard with several copies of the same picture, and it attracts more attention than a single one of the pictures would. Repeat a "motive" in the decoration of a building, and it is more likely to be noticed. Repeat a cry or call several times, and after a while it may be noticed, though not at first. The "summation of stimuli" has much the same effect as increasing the intensity of a single stimulus.

If, however, a stimulus is repeated or continued for a long time, it will probably cease to hold attention, because of its

¹ Often he pays more than the space is worth: at least doubling the size of his "ad" will not, on the whole, double the amount of attention he gets, or the number of readers whose attention he will catch. The "attention value" of an advertisement has been found by Strong to increase, not as fast as the increase in space, but about as the square root of the space occupied.

monotony, or, in other words, because it lacks the element of change.

Striking quality is an advantage, quite apart from the matter of intensity. Saturated colors, though no stronger in intensity of light than pale colors, are stronger stimuli for attention. High notes are more striking than low. Itch, tickle and pain get attention in preference to smooth touch. "Striking" cannot be defined in physical terms, but simply refers to the fact that some kinds of stimulus get attention better than others.

Definite form has the advantage over what is vague. A small, sharply defined object, that stands out from its background, attracts the eye more than a broad, indefinite expanse of light such as the sky. In the realm of sound, "form" is represented by rhythm or tune, and by other definite sequences of sound, such as occur in the jingles that catch the little child's ear.

The factors of advantage so far mentioned are native, and a stimulus possessing one or more of them is a natural attention-stimulus. But the individual also learns what is worth noticing, and what is not, and thus forms *habits of attention*, as well as habits of inattention. The automobile driver forms the habit of attending to the sound of his motor, the botanist forms the habit of noticing such inconspicuous objects as the lichens on the tree trunks. On the other hand, any one forms the habit of not noticing repeated stimuli that have no importance for him. Move into a house next the railroad, and at first you notice every train that passes; even at night you awake with a start, dreaming that some monster is pursuing you; but after a few days the trains disturb you very little, night or day. The general rule covering attention habits is this: anything that you have to work with, or like to play with, acquires the power to attract your attention, while anything that you do nothing

with loses whatever hold on your attention it may have possessed by virtue of its intensity, quality, etc.

Besides these permanent habits of attention, there are temporary adjustments determined by the *momentary interest* or desire. Stimuli relevant to the momentary interest have an unwonted hold upon attention, while things out of line with this interest may escape attention altogether, even though the same things would ordinarily be noticed. What you shall notice in the store window is governed by what you are looking for as much as by the prominence of the object in the total display. When you are angry with a person, you notice bad points about him that you usually overlook, and any aroused desire adjusts or "sets" attention in a similar way. The desire or interest of the moment *facilitates* attention to certain stimuli and *inhibits* attention to others, and is thus an important factor of advantage.

The interest of the moment is often represented by a question. Ask yourself what spots of red there are in the field of view, and immediately various red spots jump out and strike the eye; ask yourself what pressure sensations you are getting from the skin, and immediately several obtrude themselves. A question sets attention towards whatever may furnish an answer.

To sum up, we may say that three general factors of advantage determine the power of any stimulus to attract attention. There is the native factor, consisting of change, intensity, striking quality, and definite form; there is the factor of habit, dependent on past experience; and there is the factor of present interest and desire.

THE MOTOR REACTION IN ATTENTION

✓ Attention is obviously a reaction of the individual to the stimulus that gets his attention; and it is in part a motor

reaction. The movements that occur in attending to an object are such as to afford a better view of it, or a better hearing of it, or, in general, such as to bring the sense organs to bear on it as efficiently as possible.

We may distinguish two sorts of motor reaction that occur in attention: the general attentive attitude, and the special adjustments of the sense organs. An audience absorbed in a speech or musical performance gives a good picture of the general *attentive attitude*. You notice that most people look fixedly towards the speaker, as if listening with their eyes, and that many of them lean forward as if it were important to get just as close as possible. All the little restless movements cease, so that you could "hear a pin drop", and at the tensest moments even the breath is checked. The attitude of attention is one of tense immobility, with the whole body oriented towards the object of attention. When the object of attention is something not present but thought of, a somewhat similar rigid attitude is assumed; the body is apt to lean forward, the neck to be held stiff, and the eyes to "stare at vacancy", i.e., to be fixed on some convenient object as a mere resting place, while attention is fixed outside the visual field altogether.

But we spoke of attention as mobile, and it would be strange if its mobility did not show itself in the motor reaction. It does in fact show itself in the *sense organ adjustments*, which amount to exploratory reactions. Attention to an object in the hand is shown by "feeling of it", to a substance in the mouth by tasting movements, to an odor by sniffing movements, to a sound by cocking the head and turning the eyes towards the source of sound. The most instructive of this type of attention-reactions are those of the eyes. The eye is focused on the object that arouses attention, the lens being accommodated for its distance by the action of the little ciliary muscle inside the

eyeball; the two eyes are converged upon the object, so that the light from it strikes the fovea or best part of each retina; and the eyes are also turned up, down or sidewise, so as, again, to receive the light from the object upon the fovea.

This last class of eye movements is specially instructive and shows specially well the mobility of attention. Let a bright or moving object appear somewhere in the field of view—immediately the eyes turn towards it with a quick jump, fixate it for a few seconds and then jump elsewhere unless the object is found to be specially significant. Watch the eyes of one who is looking at a picture or scene of any sort, and you will see his eyes jumping hither and thither, as his attention shifts from one part of the scene to another. Ask him to abstain from this jumpy movement and let his eyes “sweep over” the scene, and he will confidently try to follow your instructions, but if you watch his eyes you will find them still jumping. In fact, “sweeping the glance” is a myth. It cannot be done. At least, there is only one case in which it can be done, and that is when there is a moving object to look at. Given an object moving at a moderate speed across the field of view, and the eyes can follow it and keep pace with it pretty accurately. But without the moving object as stimulus, the eyes can only execute the jump movement. There are thus two types of exploratory eye movement: the “jump” in passing from one object to another, and the “pursuit movement” in examining a moving object.

In reading, the eye moves by a series of short jumps from left to right along the first line of print, makes a long jump back to the beginning of the second line and another series of short jumps along that line, and so on. To appreciate the value of this jerky movement, we need to understand that each short jump occupies but a thirtieth to a fiftieth

of a second, while the "fixation pauses" between jumps last much longer, with the result that over ninety per cent. of the time spent on a line of print is fixation time, and less than ten per cent. is occupied in jumping from one fixation to the next. Now, it has been found that nothing of any consequence is seen during the eye jumps, and that the real seeing takes place only during the fixations. The jump movement, therefore, is simply a means of passing from one fixation to another with the least possible loss of time.

The eye sees an object distinctly only when at rest with respect to the object. If the object is still, the eye must be still to see it distinctly, and to see its different parts must fixate one after the other, jumping from one part to another. But if the object is in motion, the eye may still be able to see it distinctly by means of the pursuit movement, which is a sort of moving fixation.

THE SHIFTING OF ATTENTION

Eye movement affords a good picture of the mobility of attention. Ordinarily the eye shifts frequently from one part of the field of view to another. When simply exploring a scene, it shifts about in what seems an indiscriminate way, though really following the principle of deserting each object as soon as it has been examined, and jumping to that other object which next has the advantage on account of movement, brightness, color, definite form, or habit of attention. In reading, however, the eye is governed by a definite interest, and moves consecutively along the series of words, instead of shifting irregularly about the page.

A moving object, or an object that is doing something, or even a complex object that presents a number of parts to be examined in turn, can hold the eye for some time. But it is almost impossible to hold the eye fixed for any length of time on a simple, motionless, unchanging object.

Attention is mobile because it is exploratory; it continually seeks something fresh for examination. In the presence of a complex of sights and sounds and touch stimuli, it tends to shift every second or two from one part of the situation to another. Even if you are lying in bed with your eyes closed, the movement of attention still appears in the rapid succession of thoughts and images, and some shift usually occurs as often as once a second.

A few simple experiments will serve to throw the shifting of attention into clearer relief. Look fixedly at a single

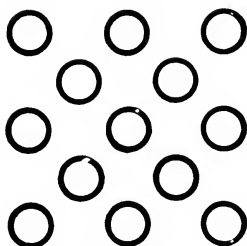

FIG. 42.—A dot figure, from Sanford. Look steadily at it.

letter written on a blank sheet of paper, and notice how one part after another of the letter stands out; notice also that attention does not stick absolutely to the letter, since thoughts obtrude themselves at intervals.

Or, make a “dot figure”, composed of six or eight or more dots arranged either regularly or irregularly, and look steadily at the collection. Probably you will find that the dots seem to fall into figures and groups, and that the grouping changes frequently. Objectively, of course, the dots are grouped in one way as much as another, so that any particular grouping is your own doing. The objective stimulus, in other words, is capable of arousing several grouping reactions on your part, and does arouse different reactions one after another

Shifting also appears in looking at an “ambiguous fig-

ure”, drawn so as to represent equally well a solid object in either of two different positions. The transparent cube, showing near and far edges alike, is a good example. Look steadily at such a drawing, and the cube will appear to

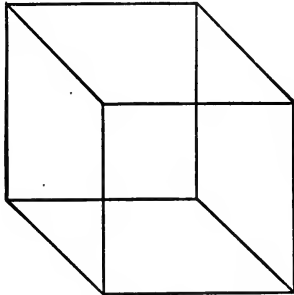

FIG. 43.—The ambiguous cube figure.

shift its position from time to time. Numerous such figures can be constructed; the most celebrated is the ambiguous staircase. Look steadily at it, and suddenly you see the under side of a flight of stairs, instead of the upper; and

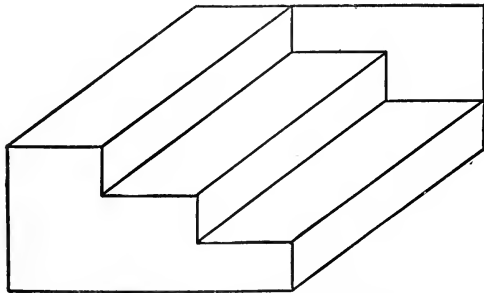

FIG. 44.—The ambiguous staircase figure.

if you keep on looking steadily, it shifts back and forth between these two positions.

A still more striking case of shifting goes by the name of “binocular rivalry”, and occurs when colors or figures that we cannot combine into a single picture are presented,

one to one eye, and the other to the corresponding part of the other retina. Hold red glass close in front of one eye and blue before the other, and look through both at once towards a bright background, and you will see red part of

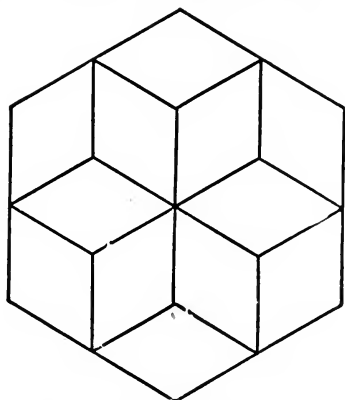

FIG. 45.—Another ambiguous figure, which can be seen in three ways.

the time and blue part of the time, the two alternating as in the case of ambiguous figures.

The stereoscope is a great convenience in applying inconsistent stimuli to the two eyes, and by aid of this instrument a great variety of experiments can be made. It is thus found that, if the field before one eye is a plain color, while the other, of a different color, has any little figure on it, this figure has a great advantage over the rival plain color and stays in sight most of the time. Anything moving in one field has a similar advantage, and a bright field has the advantage over a darker one. Thus the same factors of advantage hold good in binocular rivalry as in native attention generally.

A different kind of shifting appears in what is called "fluctuation of attention". Make a light gray smudge on a white sheet of paper, and place this at such a distance that the gray will be barely distinguishable from the white back-

ground. Looking steadily at the smudge, you will find it to disappear and reappear periodically. Or, place your watch at such a distance that its ticking is barely audible, and you will find the sound to go out and come back at intervals. The fluctuation probably represents periodic fatigue and recovery at the brain synapses concerned in observing the faint stimulus.

Shiftings of the fluctuation type, or of the rivalry type either, are not to be regarded as quite the same sort of thing as the ordinary shiftings of attention. The more typical movement of attention is illustrated by the eye movements in examining a scene, or by the sequence of ideas and images in thinking or dreaming. Rivalry and fluctuation differ from this typical shifting of attention in several ways:

(1) The typical movement of attention is quicker than the oscillation in rivalry or fluctuation. In rivalry, each appearance may last for many seconds before giving way to the other, whereas the more typical shift of attention occurs every second or so. In fact, during a rivalry or fluctuation experiment, you may observe thoughts coming and going at the same time, and at a more rapid rate than the changes in the object looked at. Attention does not really hold steady during the whole time that a single appearance of an ambiguous figure persists.

(2) Rivalry shifts are influenced very little, if at all, by the factor of momentary desire or interest, and are very little subject to control.

(3) In rivalry, the color that disappears goes out entirely, and in looking at a dot figure or ambiguous figure you get the same effect, since the grouping or appearance that gives way to another vanishes itself for the time being. But when, in exploring a scene with the eyes, you turn from one object to another, the object left behind simply retires to the background, without disappearing altogether; and,

in the same way, when attention shifts from one noise to another, the first noise does not lapse altogether but remains vaguely heard. Or when, in thinking of a number of people, one after another comes to mind, the first one does not go out of mind altogether when attention moves to the next, but remains still vaguely present for a few moments.

LAWS OF ATTENTION AND LAWS OF REACTION IN GENERAL

Shifting occurs also in reflex action. Let two stimuli be acting at once, the one calling for one reflex and the other for the opposed reflex (as flexion and extension of the same limb), and the result is that only one of these reactions will occur at the same time, the other being completely inhibited; but the inhibited reflex gets its turn shortly, provided the two stimuli continue to act, and, in fact, the two reactions may alternate in a way that reminds us of binocular rivalry or ambiguous figures. Three fundamental laws of reaction here come to light.

(1) The *law of selection*: of two or more inconsistent responses to the same situation (or complex of stimuli), only one is made at the same time.

(2) The *law of advantage*: one of the alternative responses has an initial advantage over the others, due to such factors as intensity and change in the stimulus, or to habits of reaction.

(3) The *law of shifting*: the response that has the initial advantage loses its advantage shortly, and an alternative response is made, provided the situation remains the same.

These three laws hold good of reactions at all levels, from reflex action to rational thinking.

The mobility of attention obeys these same laws; only, attention is livelier and freer in its movements than reflex action or than the shifting in rivalry. Attention is more mobile and less bound to rigid rules.

SUSTAINED ATTENTION

The mobility of attention is only half the story. When we speak, for instance, of a student as having good powers of attention, we are not thinking of mobility but rather of the opposite.

Eye movement, which we employed before as a picture of the movement of attention, affords also a picture of sustained attention. Remember how the eye moves in reading. Every second it shifts, but still it keeps to the line of print. Just so, attention keeps moving forward in the story we are reading, but sticks to the story. The more absorbed we are in the story, the more rapidly we read. Attention is sustained here, and still it moves. Sustained attention is not glued to one point, by any means, but is simply confined to a given object or theme, within which its motion may be as lively as ever.

What is it, then, that sustains attention? Evidently it is the factor of present desire or interest, already mentioned. It is a reaction-tendency, aroused to activity by some stimulus or other, unable to reach its goal instantly, but persisting in activity for a while and facilitating responses that are in its line, while inhibiting others. Such a tendency facilitates response, i.e., attention, to certain stimuli, and inhibits attention to others, thus causing them to be overlooked and neglected.

For the student, the ideal attention-sustainer is an interest in the matter presented. If, however, he cannot get up any absorbing interest in the subject-matter at once, he may generate the necessary motive force by taking the lesson as a "stunt", as something to be mastered, a spur to his self-assertion. In the old days, fear was often the motive force relied upon in the schoolroom, and the switch hanging be-

hind the efficient teacher's desk was the stimulus to sustained attention. There must be *some* tendency aroused if attention is to be sustained. The mastery impulse is certainly superior to fear for the purpose, but better than either is a genuine interest in the subject studied.

In order to get up a genuine interest in a subject—an objective or inherent interest—it is usually necessary to penetrate into the subject for some little distance. The subject may not appeal to any of our native impulses, or to any interest that has been previously acquired, and how then are we to hold attention to it long enough to discover its inherent interest? Curiosity will give us a start, but is too easily satisfied to carry us far. Fear of punishment or disapproval, hope of reward or praise, being put on our mettle, or realizing the necessity of this subject for our future success, may keep us going till we find the subject attractive in itself.

So, when the little child is learning to read, the printed characters have so little attractiveness in themselves that he naturally turns away from them after a brief exploration. But, because he is scolded when his mind wanders from those marks, because other children make fun of his blunders, because, when he reads correctly, he feels the glow of success and of applause, he does hold himself to the printed page till he is able to read a little, after which his interest in what he is reading is sufficient, without extraneous motives, to keep his nose between the covers of the story book more, perhaps, than is good for him. The little child, here, is the type of the successful student.

Attention to a subject thus passes through three stages in its development. First comes the instinctive exploratory sort of attention, favored by the native factors of advantage. Next comes the stage of forced attention, driven by extrane-

ous motives, such as fear or self-assertion. Finally arrives the stage of objective interest. In the first and last stages attention is spontaneous, in the middle stage forced. The middle stage is often called that of voluntary attention, since effort has to be exerted to sustain attention, while the first and last stages, being free from effort, may be called involuntary.

DISTRACTION

Distraction is an important topic for consideration in connection with sustained attention. A distraction is a stimulus that attracts attention away from the thing to which we mean to attend. There are always competing stimuli, and the various factors of advantage, especially desire or interest, determine which stimulus shall get attention at any moment.

In the excited insane condition known as "mania" or the "manic state", the patient is excessively distractible. He commences to tell you something, all interest in what he has to say, but, if you pull out your watch while he is talking, he drops his story in the middle of a sentence and shifts to some remark about the watch. He seems to have no impulse persistent enough to hold his thoughts steady. There are contrary insane conditions in which it is almost impossible to distract the patient from his own inner broodings, so much is he absorbed in his own troubles.

Distraction is a favorite topic for experiment in the laboratory. The subject is put to work adding or typewriting, and works for a time in quiet, after which disturbances are introduced. A bell rings, a phonograph record is played, perhaps a perfect bedlam of noise is let loose; with the curious result that the subject, only momentarily distracted, accomplishes more work rather than less. The distraction has acted as a stimulus to greater effort, and by this effort

is overcome. This does not always happen so in real life, but it shows the possibilities of sustained attention.

There are several ways of overcoming a distraction. First, greater energy may be thrown into the task one is trying to perform. The extra effort is apt to show itself in gritting the teeth, reading or speaking aloud, and similar muscular activity which, while entirely unnecessary for executing the task in hand, helps by keeping the main stream of energy directed into the task instead of towards the distracting stimuli. Effort is necessary when the main task is uninteresting, or when the distraction is specially attractive, or even when the distraction is something new and strange and likely to arouse curiosity. But one may grow accustomed or "adapted" to an oft-recurring distraction, so as to sidetrack it without effort; in other words, a habit of inattention to the distracting stimulus may be formed. There is another, quite different way of overcoming a distraction, which works very well where it can be employed, and that is to couple the distraction to the main task, so as to deal with both together. An example is seen in piano playing. The beginner at the piano likes to play with the right hand alone, because striking a note with the left hand distracts him from striking the proper note with the right. But, after practice, he couples the two hands, strikes the bass note of a chord with the left hand while his right strikes the other notes of the same chord, and much prefers two-handed to one-handed playing. In short, to overcome a distraction, you either sidetrack it or else couple it to your main task.

DOING TWO THINGS AT ONCE

The subject of distraction brings to mind the question that is often asked, "Can any one do two things at once?" In this form, the question admits of but one answer, for we

are always doing at least two things at once, provided we are doing anything else besides breathing. We have no trouble in breathing and walking at the same time, nor in seeing while breathing and walking, nor even in thinking at the same time. But breathing, walking, and seeing are so automatic as to require no attention. The more important question then, is whether we can do two things at once, when each demands careful attention.

The redoubtable Julius Cæsar, of happy memory, is said to have been able to dictate at once to several copyists. Now, Cæsar's copyists were not stenographers, but wrote in long-hand, so that he could speak much faster than they could write. What he did, accordingly, was undoubtedly to give the first copyist a start on the first letter he wished to send, then turn to the second and give him a start on the second letter, and so on, getting back to the first in time to keep him busy. Quite an intellectual feat, certainly! But not a feat requiring absolutely simultaneous attention to several different matters. In a small way, any one can do something of the same kind. It is not impossible to add columns of numbers while reciting a familiar poem; you get the poem started and then let it run on automatically for a few words while you add a few numbers, switch back to the poem and then back to the adding, and so on. But in all this there is no doing of two things, attentively, at the same instant of time.

You may be able, however, to combine two acts into a single coördinated act, in the way just described under the head of distraction, and give undivided attention to this compound act.

THE SPAN OF ATTENTION

Similar to the question whether we can attentively perform more than a single act at a time is the question of

how many different objects we can attend to at once. The "span of attention" for objects of any given kind is measured by discovering how many such objects can be clearly seen, or heard, or felt, in a single instant of time. Measurement of this "span" is one of the oldest experiments in psychology. Place a number of marbles in a little box, take a single peek into the box and see if you know how many marbles are there. Four or five you can get in a single glance, but with more there you become uncertain.

In the laboratory we have "exposure apparatus" for displaying a card for a fifth of a second or less, just enough time for a single glance. Make a number of dots or strokes on the card and see whether the subject knows the number on sight. He can tell four or five, and beyond that makes many mistakes. *eq. Tachistoscope.*

Expose letters not making any word and he can read about four at a glance. But if the letters make familiar words, he can read three or four words at a glance. If the words make a familiar phrase, he gets a phrase of several words, containing as many as twenty letters, at a single glance.

Expose a number of little squares of different colors, and a well-trained subject will report correctly as many as five colors, though he cannot reach this number every time.

SUMMARY OF THE LAWS OF ATTENTION

Bringing together now what we have learned regarding the higher and more difficult forms of attention, as revealed by sustained attention and work under distraction, by the span of attention and by trying to do two things at once, we find the previously stated three laws of attention further illustrated, and a couple of new laws making their appearance.

(1) The *law of selection* still holds good in these more

difficult performances, since only one attentive response is made at the same instant of time. Automatic activities may be simultaneously going on, but any two attentive responses seem to be inconsistent with each other, so that the making of one excludes the other, in accordance with the general law of selection.

What shall we say, however, of reading four disconnected letters at the same time, or of seeing clearly four colors at the same time? Here, it would seem, several things are separately attended to at once. The several things are similar, and close together, and the responses required are all simple and much alike. Such responses, under such very favorable conditions, are perhaps, then, not inconsistent with each other, so that two, three, or even four such attentive responses may be made at the same time.

(2) The *law of advantage* holds good, as illustrated by the fact that some distractions are harder to resist than others.

(3) The *law of shifting* holds good, as illustrated by the constant movement of attention, even when it is "sustained", and by the alternation between two activities when we are trying to carry them both along simultaneously.

(4) The *law of sustained attention*, or of *tendency* in attention, is the same old law of tendency that has shown itself repeatedly in earlier chapters. A tendency, when aroused to activity, facilitates responses that are in its line and inhibits others. A tendency is thus a strong factor of advantage, and it limits the shifting of attention.

(5) A new law has come to light, the *law of combination*, which reads as follows: *a single response may be made to two or more stimuli; or, two or more stimuli may arouse a single joint response.*

Even though, in accordance with the law of selection, only one attentive response is made at the same time, more than

one stimulus may be dealt with by this single attentive response. Groups of four dots are grasped as units, familiar words are grasped as units. Notice that these units are our own units, not external units. Physically, a row of six dots is as much a unit as a row of four; but we grasp the four as a unit in a way that we cannot apply to the six. Physically, six letters are as much a unit when they do not form a word as when they do; but we can make a unitary response to the six in the one case and not in the other. The response is a unit, though aroused by a number of separate stimuli.

The law of combination, from its name, is open to a possible misconception, as if we reached out and grasped and combined the stimuli, whereas ordinarily we do nothing to the stimuli, except to see them and recognize them, or in some such way respond to them. The combination is something that happens *in us*; it is our response. If the expression were not so cumbersome, we might more accurately name this law that of "unitary response to a plurality of stimuli".

Sometimes, indeed, we do make an actual motor response to two or more stimuli, as when we strike a chord of several notes on the piano. The law of combination still holds good here, since the movements of the two hands are coordinated into a single act, which is thought of as a unit ("striking a chord"), attended to as a unit, and executed as a unit. Such coördinated movements may be called "higher motor units", and we shall find much to say regarding them when we come to the subject of learned reactions. The law of combination, all in all, will be found later to have extreme importance in learned reactions.

Passing now to another side of the study of attention, we shall immediately come across a sixth law to add to our list.

ATTENTION AND DEGREE OF CONSCIOUSNESS

Up to this point, the introspective side of the psychology of attention has not been considered. One of the surest of all introspective observations belongs right here, to the effect that we are more conscious of that to which we are attending than of anything else. Of two stimuli acting at once upon us, we are the more conscious of that one which catches our attention; of two acts that we perform simultaneously, that one is more conscious that is performed attentively.

We need not be entirely unconscious of the act or the stimulus to which we are not attending. We may be dimly conscious of it. There are degrees of consciousness. Suppose, for example, you are looking out of the window while "lost in thought". You are most conscious of the matter of your thoughts, but conscious to a degree of what you see out of the window. Your eyes are focused on some particular object outside, and you are more conscious of this than of other objects seen in indirect vision, though even of these last you are not altogether unconscious. Consciousness shades off from high light to dim background.

The "field of attention" is the maximum or high light of consciousness; it comprises the object under attentive observation, the reaction attentively performed. The "field of consciousness" includes the field of attention and much besides. It includes objects of which we are vaguely aware, desires active but not clearly formulated, feelings of pleasantness or unpleasantness, of tension, excitement, confidence, etc.

Apparently the field of consciousness shades off gradually into the field of unconscious activity. Some physiological processes go on unconsciously, and very habitual movements may be almost or entirely unconscious. The boundary be-

tween what is vaguely conscious and what is entirely unconscious is necessarily very vague itself, but the probability is that the field of consciousness is broader than we usually suspect, and that many activities that we ordinarily think of as unconscious, because we do not observe them at the time nor remember them later, lie really near the margin of the field of consciousness, but inside that field. "Unconscious motives", such as spite or pride often seem to be, are probably vaguely conscious rather than unconscious. We shall return to the fascinating topic of the unconscious at the close of the book.

Degree of consciousness does not always tally with intensity of sensation or energy of muscular action. You may be more conscious of a slight but significant sound than of much louder noises occurring at the same time. You may be more conscious of a delicate finger movement than of a strong contraction of big muscles occurring at the same time. Degree of consciousness goes with degree of *mental* activity. Of all the reactions we are making at the same time—and usually there are several—the most active in a mental way is the most conscious. The slight sound arouses intense mental response because it means something of importance—like the faint cry of the baby upstairs, noticed instead of the loud noises of the street. The delicate finger movement aims at some difficult result, while the big muscles may be doing their accustomed work automatically.

It is not always the most efficient mental process that is most conscious; indeed, practising an act makes it both more efficient and less conscious. It is, rather, the less efficient processes that require attention, because they require mental work to keep them going straight.

Our sixth law of attention, emerging from this introspective study, is naturally of a different style from the remainder of the list, which were objectively observed; yet it

is no less certain and perhaps no less significant. It may be called:

(6) *The law of degrees of consciousness*, and thus stated: *An attentive response is conscious to a higher degree than any inattentive response made at the same time.* An inattentive response may be dimly conscious or, perhaps, altogether unconscious. The less familiar the response, and the higher it stands in the scale of mental performances, the more attentive it is, and the more conscious.

THE MANAGEMENT OF ATTENTION

Attentive observation is more trustworthy than inattentive, and also gives more facts. Attentive movement is more accurate than inattentive, and may be quicker as well. Attentive study gives quicker learning than inattentive, and at the same time fixes the facts more durably.

Shall we say, then, "Do everything attentively"? But that is impossible. We sense so many stimuli at once that we could not possibly attend to all of them. We do several things at once, and cannot give attention to them all. A skilful performance consists of many parts, and we cannot possibly give careful attention to all the parts. Attention is necessarily selective, and the best advice is, not simply to "be attentive", but to attend to the right things.

In observation, the best plan is obviously to decide beforehand exactly what needs to be observed, and then to focus attention on this precise point. That is the principle underlying the remarkably sure and keen observation of the scientist. Reading may be called a kind of observation, since the reader is looking for what the author has to tell; and the rule that holds for other observation holds also for reading. That is to say that the reader finds the most when he knows just what he is looking for. We can learn some-

thing here from story-reading, which is the most efficient sort of reading, in the sense that you get the point of the story better than that of more serious reading matter, the reason being that attention is always pressing forward in the story, looking for something very definite. You want to know how the hero gets out of the fix he is in, and you press forward and find out with great certainty and little loss of time. The best readers of serious matter have a similar eagerness to discover what the author has to say; they get the author's question, and press on to find his answer. Such readers are both quick and retentive. The dawdling reader, who simply spends so much time and covers so many pages, in the vague hope that something will stick, does not remember the point because he never got the point, and never got it because he wasn't looking for it.

In skilled movement, or skilled action of any sort, the best rule is to fix attention on the end-result or, if the process is long, on the result that immediately needs to be accomplished. "Keep your eye on the ball" when the end just now to be achieved is hitting the ball. Attention to the details of the process, though necessary in learning a skilled movement, is distracting and confusing after skill has been acquired. The runner does not attend to his legs, but to the goal or, if that is still distant, to the runner just ahead of him.

THEORY OF ATTENTION

The chief facts to take account of in attempting to form a conception of the brain action in attention are mobility, persistence in spite of mobility, and focusing.

The mobility of attention must mean that brain activities are in constant flux, with nerve currents continually shooting hither and thither and arousing ever fresh groups of neurones; but sustained attention means that a brain activ-

ity (representing the desire or interest or reaction-tendency dominant at the time) may *persist* and limit the range of the mobile activities, by facilitating some of these and inhibiting others.

The “focusing” of mental activity is more difficult to translate into neural terms. The fact to be translated is that, while several mental activities may go on at once, only one occupies the focus of attention. This must mean that, while several brain activities go on at once, one is superior in some way to the rest. The superiority might lie in greater intensity of neurone action, or in greater extent; that is, one brain activity is bigger in some way than any other occurring at the same time—bigger either because the neurones in it are working more energetically or because it includes a larger number of active neurones.

But why should not two equally big brain activities sometimes occur at the same moment, and attention thus be divided? The only promising hypothesis that has been offered to explain the absence of divided attention is that of “neurone drainage”, according to which one or the other of two neurone groups, simultaneously aroused to activity, drains off the energy from the other, so putting a quietus on it. Unfortunately, this hypothesis explains too much, for it would make it impossible for minor brain activities to go on at the same time as the major one, and that would mean that only one thing could be done at a time, and that the field of consciousness was no broader than the field of attention. On the whole, we must admit that we do not know exactly what the focusing of attention can mean in brain terms.

EXERCISES

1. Outline the chapter, in the form of a number of "laws", putting under each law the chief facts that belong there.

2. See if you can verify, by watching another person's eyes, the statements made on page 250 regarding eye movements.

3. Choose a spot where there is a good deal going on, stay there for five minutes and jot down the things that attract your attention. Classify the stimuli under the several "factors of advantage".

4. Mention some stimulus to which you have a habit of attention, and one to which you have a habit of inattention.

5. Close the eyes, and direct attention to the field of cutaneous and kinesthetic sensations. Do sensations emerge of which you are ordinarily only dimly conscious? Does shifting occur?

6. Of the several factors of advantage, which would be most effective in catching another person's attention, and which in holding his attention?

7. How does attention, in a blind person, probably differ from that of a seeing person?

8. Doing two things at once. Prepare several columns of one-place numbers, ten digits in a column. Try to add these columns, at the same time reciting a familiar poem, and notice how you manage it, and how accurate your work is.

9. Consider what would be the best way to secure sustained attention to some sort of work from which your mind is apt to wander.

REFERENCES

Walter B. Pillsbury gives a full treatment of the subject in his book on *Attention*, 1908, and a condensed account of the matter in Chapter V of his *Essentials of Psychology*, 2nd edition, 1920.

Another full treatment is that of Titchener, in his *Textbook of Psychology*, 1909, pp. 265-302.

On the topic of distraction, see John J. B. Morgan's *Overcoming of Distraction and Other Resistances*, 1916.

CHAPTER XII

INTELLIGENCE

HOW INTELLIGENCE IS MEASURED, WHAT IT CONSISTS
IN, AND EVIDENCE OF ITS BEING LARGELY A MAT-
TER OF HEREDITY

Before leaving the general topic of native traits and passing to the process of learning or acquiring traits, we need to complete our picture of the native mental constitution by adding intelligence to reflex action, instinct, emotion, feeling, sensation and attention. Man is an intelligent animal by nature. The fact that he is the most intelligent of animals is due to his native constitution, as the fact that, among the lower animals, some species are more intelligent than others is due to the native constitution of each species. A rat has more intelligence than a frog, a dog than a rat, a monkey than a dog, and a man than a monkey, because of their native constitutions as members of their respective species.

But the different individuals belonging to the same species are not all equal in intelligence, any more than in size or strength or vitality. Some dogs are more intelligent than others, and the same is notably true of men. Now, are these differences between members of the same species due to heredity or environment? This question we can better approach after considering the methods by which psychologists undertake to measure intelligence; and an analysis of these methods may also serve to indicate what is included under the term "intelligence".

INTELLIGENCE TESTS

Not far from the year 1900 the school authorities of the city of Paris, desiring to know whether the backwardness of many children in school resulted from inattention, mischievousness and similar difficulties of a moral nature, or from genuine inability to learn, put the problem into the hands of Alfred Binet, a leading psychologist of the day; and within a few years thereafter he and a collaborator brought out the now famous Binet-Simon tests for intelligence. In devising these tests, Binet's plan was to leave school knowledge to one side, and look for information and skill picked up by the child from his elders and playmates in the ordinary experience of life. Further, Binet wisely decided not to seek for any *single* test for so broad a matter as intelligence, but rather to employ many brief tests and give the child plenty of chances to demonstrate what he had learned and what he could do. These little tests were graded in difficulty from the level of the three-year-old to that of the twelve-year-old, and the general plan was to determine how far up the scale the child could successfully pass the tests.

These were not the first tests in existence by any means, but they were the first attempt at a measure of general intelligence, and they proved extraordinarily useful. They have been added to and revised by other psychologists, notably by Terman in America, who has extended the scale of tests up to the adult level. A few samples from Terman's revision will give an idea of the character of the Binet tests.

From the tests for three-year-olds: Naming familiar objects—the child must name correctly at least three of five common objects that are shown him.

Six-year test: Finding omissions in pictures of faces, from which the nose, or one eye, etc., is left out. Four such pictures are shown, and three correct responses are required to pass the test.

Eight-year test: Tell how wood and coal are alike; and so with three other pairs of familiar things; two out of four correct responses are required to pass the test.

Twelve-year test: Vocabulary test—rough definitions showing the child's understanding of forty words out of a standard list of one hundred.

The question may be raised, "Why such arbitrary standards—three out of five required here, two out of four there, forty out of a hundred the next time?" The answer is that the tests have been standardized by actual trial on large numbers of children, and so standardized that the average child of a given age can just barely pass the tests of that age.

Intelligence is measured by Binet on a scale of *mental age*. The average child of, let us say, eight years and six months is said to have a mental age of eight years and six months; and any individual who does just as well as this is said to have this mental age, no matter what his chronological age may be. The average child of this age passes all the tests for eight years and below, and three of the six tests for age nine; or passes an equivalent number of tests from the total series. Usually there is some "scatter" in the child's successes, as he fails in a test here and there below his mental age, and succeeds here and there above his mental age, but the failures below and the successes above balance each other in the average child, so that he comes out with a mental age equal to his chronological age.¹

¹ The Binet scale, it must be understood, is an instrument of precision, not to be handled except by one who has been thoroughly trained in its use. It looks so simple that any student is apt to say, "Why, I could give those tests!" The point is that he couldn't—not until he knew the tests practically by heart, not till he had standardized his manner of conducting them to agree perfectly with the prescribed manner and till he knew how to score the varying answers given by different children according to the scoring system that goes with the tests, and not till, by experience in handling children in the tests, he was able to secure the child's confidence and get him to do his best, without, however, giving the child any assistance beyond what is prescribed. Many superior persons have looked down on the psychological examiner with his (or her) assortment of little tests, and have said, "Certainly no special training is necessary to give these tests. You simply want to find out whether the child can do these stunts. I can find out as well as you." They miss the point altogether. The question is not whether

If a child's mental age is the same as his chronological age, he is just average, neither bright nor dull. If his mental age is much above his chronological, he is bright; if much below, dull. His degree of brightness or dullness can be measured by the number of years his mental age is above or below his chronological age. He is, mentally, so many years advanced or retarded.

Brightness or dullness can also be measured by the *intelligence quotient*, which is employed so frequently that it is customarily abbreviated to "IQ". This is the mental age divided by the chronological, and is usually expressed in per cent. The IQ of the exactly average child, of any age, is 1, or 100 per cent. The IQ of the bright child is above 100 and of the dull child below 100. About sixty per cent. of all children have an IQ between 90 and 110, twenty per cent. are below 90 and twenty per cent. above 110. The following table gives the distribution in somewhat greater detail:

IQ below 70,	1%
IQ 70-79,	5%
IQ 80-89,	14%
IQ 90-99,	30%
IQ 100-109,	30%
IQ 110-119,	14%
IQ 120-129,	5%
IQ over 129,	1%

100

the child *can* do these stunts (with an undefined amount of assistance), but whether he *does* them under carefully prescribed conditions. The child is given two, three or four dozen chances to see how many of them he will accept; and the whole scale has been standardized by try-out on many children of each age, and so adapted that, when given according to instructions, it will give a correct measure of the child's mental age. But when given by superior persons in ignorance of its true character, it gives results very wide of the mark. So much by way of caution.

For convenience, those with IQ under 70 are sometimes labeled "feeble-minded", and the others, in order, "border-line", "low normal", "average" (from 90 to 110), "superior", "very superior", "exceedingly superior"; but this is arbitrary and really unscientific, for what the facts show is not a separation into classes, but a continuous gradation from one extreme to the other. The lower extreme is near zero, and the upper extreme thus far found is about 180.

While the mental age tells an individual's intellectual level at a given time, the IQ tells how fast he has progressed. An IQ of 125 means that he has picked up knowledge and skill 25 per cent. faster than the average individual—that he has progressed as far in four years as the average child does in five, or as far in eight as the average does in ten, or as far in twelve as the average does in fifteen. The IQ usually remains fairly constant as the child grows older, and thus represents his rate of mental growth. It furnishes a pretty good measure of the individual's intelligence.

PERFORMANCE TESTS

Since, however, the Binet tests depend greatly on the use of language, they are not fair to the deaf child, nor to the child with a speech defect, nor to the foreign child. Also, some persons who are clumsy in managing the rather abstract ideas dealt with in the Binet tests show up better in managing concrete objects. For all such cases, *performance tests* are useful. Language plays little part in a performance test, and concrete objects are used. The "form board" is a good example. Blocks of various simple shapes are to be fitted into corresponding holes in a board; the time of performance is measured, and the errors (consisting in trying to put a block into a differently shaped hole) are also counted. To the normal adult, this task seems too simple

to serve as a test for intelligence, but the young child finds it difficult, and the mentally deficient adult goes at it in the same haphazard way as a young child, trying to force the square block into the round hole. He does not pin himself down to the one essential thing, which is to match blocks and holes according to shape.

Another good performance test is the "picture completion". A picture is placed before the child, out of which several square holes have been cut. These cut-out pieces are mounted on little blocks, and there are other similar blocks with more or less irrelevant objects pictured on them. The child must select from the whole collection of little blocks the one that belongs in each hole in the picture. The better his understanding of the picture, the better his selection.

GROUP TESTING

The tests so far described, because they have to be given to each subject individually, require a great deal of time from the trained examiner, and tests are also needed which can be given to a whole group of people at once. For persons who can read printed directions, a group test can easily be conducted, though much preliminary labor is necessary in selecting and standardizing the questions used. Group testing of foreigners, illiterates, and young children is more difficult, but has been accomplished, the directions being conveyed orally or by means of pantomime.

The first extensive use of group intelligence tests was made in the American Army during the Great War. A committee of the American Psychological Association prepared and standardized the tests, and persuaded the Army authorities to let them try them out in the camps. So successful were these tests—when supplemented, in doubtful cases, by individual tests—that they were adopted in the receiving

camps; and they proved very useful both in detecting those individuals whose intelligence was too low to enable them to learn the duties of a soldier, and those who, from high intelligence, could profitably be trained for officers.

The "Alpha test", used on recruits who could read, consisted of eight pages of questions, each page presenting a different type of problem for solution. On the first page were rows of circles, squares, etc., to which certain things were to be done in accordance with spoken commands. The subject had to attend carefully to what he was told to do, since he was given each command only once, and some of the commands called for rather complicated reactions. The second page consisted of arithmetical problems, ranging from very simple at the top of the page to more difficult ones below, though none of them went into the more technical parts of arithmetic. One page tested the subject's information on matters of common knowledge; and another called for the selection of the best of three reasons offered for a given fact, as, for example, "Why is copper used for electric wires? Because—it is mined in Montana—it is a good conductor—it is the cheapest metal." Another page presented disarranged sentences (as, "wet rain always is", or "school horses all to go"), to be put straight mentally, and indicated on the paper as true or false.

Many group tests are now in use, and among them some performance tests. In the latter, pictures are often employed; sometimes the subject has to complete the picture by drawing in a missing part, sometimes he has to cancel from the picture a part that is superfluous. He may have to draw a pencil line indicating the shortest path through a maze, or he may have to continue a series of marks which starts off according to a definite plan. The problems set him under each class range from very easy to fairly difficult.

SOME RESULTS OF THE INTELLIGENCE TESTS

The principal fact discovered by use of standardized intelligence tests is that the tests serve very well the purpose for which they were intended. In expert hands they actually give a fairly reliable measure of the individual's intelligence. They have located the trouble in the case of many a backward school child, whose intelligence was too low to enable him to derive much benefit from the regular school curriculum. His schooling needed to be adjusted to his intelligence so as to prepare him to do what he was constitutionally able to do.

On the other hand, it sometimes happens that a child who is mischievous and inattentive in school, and whose school work is rather poor, tests high in intelligence, the trouble with him being that the work set him is below his mental level and therefore unstimulating. Such children do better when given more advanced work. The intelligence tests are proving of great service in detecting boys and girls of superior intelligence who have been dragging along, forming lazy habits of work, and not preparing for the kind of service that their intelligence should enable them to give.

Some results obtained by the "Alpha test" are given in the following table, and in the diagram which restates the facts of the table in graphic form. The Alpha test included 212 questions in all, and a correct answer to any question netted the subject one point. The maximum score was thus 212 points, a mark which could only be obtained by a combination of perfect accuracy and very rapid work (since only a limited time was allowed for each page of the test). Very seldom does even a very bright individual score over 200 points. The table shows the approximate per cent. of individuals scoring between certain limits; thus,

of men drafted into the Army, approximately 3 per cent. scored below 15 points, 12 per cent. scored from 15 to 29 points, etc. Of college freshmen, practically none score below 75 points, 1 per cent. score from 75 to 89 points, etc.

Scores	Per cent. of drafted men making these scores	Per cent. of college freshmen making these scores
0-14 points	3	0
15-29 "	12	0
30-44 "	15	0
45-59 "	16 ⁴⁶	0
60-74 "	13	0
75-89 "	11 ⁴¹	1
*90-104 "	9	4
105-119 "	7	8
120-134 "	6	14
135-149 "	4	23
150-164 "	2	24
165-179 "	1.3	18
180-194 "	0.5	7
195-212 "	0.2	1
	100	100

The "drafted men", consisting of men between the ages of twenty-one and thirty-one, fairly represent the adult male white population of the country, except in two respects. Many able young men were not included in the draft, having previously volunteered for officers' training camps or for special services. Had they been included, the percentages making the higher scores would have gone up slightly. On the other hand, many men of very low intelligence never reached the receiving camps at all, being inmates of institutions for the feeble-minded or excluded from the draft because of known mental deficiency; and, of those who reached

the camps, many, being illiterate, did not take the Alpha test. It is for this reason that the graph for drafted men stops rather short at the lower end; to picture fairly the distri-

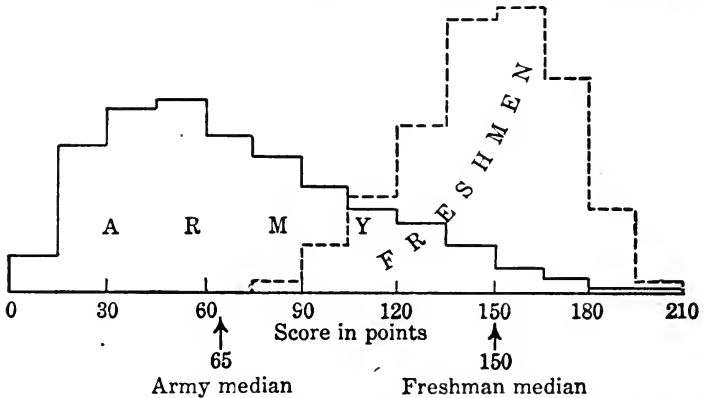

FIG. 46.—Distribution of the scores of drafted men, and also of college freshmen, in the Alpha test. The height of the broken line above the base line is made proportional to the percent of the group that made the score indicated just below along the base line.

bution of intelligence, it should taper off to the left, beyond the zero of the Alpha test.

College freshmen evidently are, as they should be, a highly selected group in regard to intelligence. The results obtained at different colleges differ somewhat, and the figures here given represent an approximate average of results obtained at several colleges of high standing. The median¹

¹ The "median" is a statistical measure very similar to the average; but, while the average score would be obtained by adding together the scores of all the individuals and dividing the sum by the number of individuals tested, the median is obtained by arranging all the individual scores in order, from the lowest to the highest, and then counting off from either end till the middle individual is reached; his score is the median. (If the number of individuals tested is an *even* number, there are two middle individuals, and the point midway between them is taken as the median.) Just as many individuals are below the median as above it. The median is often preferred to the average in psychological work, not only because it is more easily computed, but because it is less affected by the eccentric or unusual performances of a few individuals, and therefore more fairly represents the whole population.

score for freshmen has varied, at different colleges, from 140 to 160 points.

It will be noticed in the graph that none of the freshmen score as low as the median of the drafted men. All of the freshmen, in fact, lie well above the median for the general population. A freshman who scores below 100 points finds it very difficult to keep up in his college work. Sometimes, it must be said, a freshman who scores not much over 100 in the test does very well in his studies, and sometimes one who scores very high in the test has to be dropped for poor scholarship, but this last is probably due to distracting interests.

No such sampling of the adult female population has ever been made as was afforded by the draft, and we are not in a position to compare the average adult man and woman in regard to intelligence. Boys and girls under twelve average almost the same, year by year, according to the Binet tests. In various other tests, calling for quick, accurate work, girls have on the average slightly surpassed boys of the same age, but this may result from the fact that girls mature earlier than boys; they reach adult height earlier, and perhaps also adult intelligence. College women, in the Alpha test, score on the average a few points below college men, but this, on the other hand, may be due to the fact that the Alpha test, being prepared for men, includes a few questions that lie rather outside the usual range of women's interests. On the whole, tests have given very little evidence of any significant difference between the general run of intelligence in the two sexes.

LIMITATIONS OF THE INTELLIGENCE TESTS

Tests of the Binet or Alpha variety evidently do not cover the whole range of intelligent behavior. They do not test

the ability to manage carpenter's or plumber's tools or other concrete things, they do not test the ability to manage people, and they do not reach high enough to test the ability to solve really big problems.

Regarding the ability to manage concrete things, we have already mentioned the performance tests, which provide a necessary supplement to the tests that deal in ideas expressed in words. It is an interesting fact that some men whose mental age is below ten, according to the Binet tests, nevertheless have steady jobs, earn good wages, and get on all right in a simple environment. There are many others, with a mental age of ten or eleven, who cannot master the school work of the upper grades, and yet become skilled workmen or even real artists. Now, it takes mentality to perform skilled or artistic work; only, the mentality is different from that demanded by what we call "intellectual work".

Managing people requires tact and leadership, which are obviously mental traits, though not easily tested. It is seldom that a real leader of men scores anything but high in the intelligence tests, but it more often happens that an individual who scores very high in the tests has little power of leadership. In part this is a matter of physique, or of temperament, rather than of intelligence, but in part it is a matter of *understanding* people and seeing how they can be influenced and led.

Though the intelligence tests deal with "ideas", they do not, as so far devised, reach up to the great ideas nor make much demand on the superior powers of the great thinker. If we could assemble a group of the world's great authors, scientists and inventors, and put them through the Alpha test, it is probable that they would all score high, but not higher than the upper ten per cent. of college freshmen. Had their IQ's been determined when they were children,

probably all would have measured over 130 and some as high as 200, but the tests would not have distinguished these great geniuses from the gifted child who is simply one of a hundred or one of a thousand.

THE CORRELATION OF ABILITIES

There is no opposition between "general intelligence", as measured by the tests, and the abilities to deal with concrete things, with people, or with big ideas. Rather, there is a considerable degree of correspondence. The individual who scores high in the intelligence tests is likely, but not certain, to surpass in these respects the individual who scores low in the tests. In technical language, there is a "positive correlation" between general intelligence and ability to deal with concrete things, people and big ideas, but the correlation is not perfect.

Correlation is a statistical measure of the degree of correspondence. Suppose, for an example, we wish to find out how closely people's weights correspond to their heights. Stand fifty young men up in single file in order of height, the tallest in front, the shortest behind. Then weigh each man, and shift them into the order of their weights. If no shifting whatever were needed, the correlation between height and weight would be perfect. Suppose the impossible, that the shortest man was the heaviest, the tallest the lightest, and that the whole order needed to be exactly reversed; then we should say that the correlation was perfectly inverse or negative. Suppose the shift from height order to weight order mixed the men indiscriminately, so that you could not tell *anything* from a man's position in the height order as to what his position would be in the weight order; then we should have "zero correlation". The actual result, however, would be that, while the height order would be some-

what disturbed in shifting to the weight order, it would not be entirely lost, much less reversed. That is, the correlation between height and weight is positive but not perfect.

Statistics furnishes a number of formulæ for measuring correlations, formulæ which agree in this, that perfect positive correlation is indicated by the number $+1$, perfect negative correlation by the number -1 , and zero correlation by 0 . A correlation of $+ .8$ indicates close positive correspondence, though not perfect correspondence; a correlation of $+ .3$ means a rather low, but still positive, correspondence; a correlation of $- .6$ means a moderate tendency towards inverse relationship.

The correlation between two good intelligence tests, such as the Binet and the Alpha, comes out at about $+ .8$, which means that if a fair sample of the general population, ranging from low to high intelligence, is given both tests, the order of the individuals as measured by the one test will agree pretty closely with the order obtained with the other test. The correlation between a general intelligence test and a test for mechanical ability is considerably lower but still positive, coming to about $+ .4$. Few if any real negative correlations are found between different abilities, but low positive or approximately zero correlations are frequent between different, rather special abilities.

In other words, there is no evidence of any antagonism between different sorts of ability, but there is plenty of evidence that different special abilities may have little or nothing in common.¹

¹ Possibly some readers would like to see a sample of the statistical formulæ by which correlation is measured. Here is one of the simplest. Number the individuals tested in their order as given by the first test, and again in their order as given by the second test, and find the difference between each individual's two rank numbers. If an individual who ranks no. 5 in one test ranks no. 12 in the other, the difference in his rank numbers is 7. Designate this difference by the letter D , and the whole number of individuals tested by n . Square each D , and get

GENERAL FACTORS IN INTELLIGENCE

If now we try to analyze intelligence and see in what it consists, we can best proceed by reviewing the intelligence tests, and asking how it is that an individual succeeds in them. Passing the tests is a very specific instance of intel-

the sum of all the squares, calling this sum "sum of D^2 ". Then the correlation is given by the formula,

$$1 - \frac{6 \times \text{sum of } D^2}{n(n^2 - 1)}$$

As an example in the use of this formula, take the following:

Individuals tested	Rank of each individual in first test	Rank of each individual in second test	D	D^2
Albert	3	5	2	4
George	7	6	1	1
Henry	5	3	2	4
James	2	1	1	1
Stephen	1	4	3	9
Thomas	4	2	2	4
William	6	7	1	1

$$n = 7$$

$$n^2 - 1 = 48$$

$$\text{sum of } D^2 = 24$$

$$6 \times \text{sum of } D^2 = 144$$

$$1 - \frac{6 \times \text{sum of } D^2}{n(n^2 - 1)}$$

$$= 1 - \frac{144}{7 \times 48}$$

$$= +.57$$

In order to get a full and true measure of the correlation between two tests, the following precautions are necessary:

- (1) The *same individuals* must be given both tests.
- (2) The number of individuals tested must be as great as 15 or 20, preferably more.
- (3) The individuals should be a fair sample of the population in regard to the abilities tested; they should not be so selected as to represent only a small part of the total range of ability.
- (4) The tests should be thorough enough to determine each individual's rank in each test, with a high degree of certainty. Sloppy testing gives a correlation nearer zero than it should be, because it "pies" the true orders to some extent.

ligent behavior, and an analysis of the content of the tests should throw some light on the nature of intelligence.

The first thing that strikes the eye in looking over the tests is that they call for so many different reactions. They call on you to name objects, to copy a square, to tell whether a given statement is true or false, to tell wherein two objects are alike or different. The first impression, then, is that intelligence consists simply in doing a miscellaneous lot of things and doing them right.

But can we not state in more general terms how the individual who scores high in the tests differs from one who scores low? If you survey the test questions carefully, you begin to see that the person who passes them must possess certain general characteristics, and that lack of these characteristics will lead to a low score. We may speak of these characteristics as "general factors" in intelligent behavior.

First, the tests evidently require the use of past experience. They call, not for instinctive reactions, but for previously learned reactions. Though the Binet tests attempt to steer clear of specific school knowledge, they do depend upon knowledge and skill picked up by the child in the course of his ordinary experience. They depend on the ability to learn and remember. One general factor in intelligence is therefore *retentiveness*.

But the tests do not usually call for simple memory of something previously learned. Rather, what has been previously learned must be applied, in the test, to a more or less novel problem. The subject is asked to do something a little different from anything he has previously done, but similar enough so that he can make use of what he has learned. He has to *see the point* of the problem now set him, and to *adapt* what he has learned to this novel situation. Perhaps "seeing the point" and "adapting oneself to

a novel situation" are to be held apart as two separate general factors in intelligence, but on the whole it seems possible to include both under the general head, *responsiveness to relationships*, and to set up this characteristic as a second general factor in intelligence.

In the form board and picture completion tests, this responsiveness to relationships comes out clearly. To succeed in the form board, the subject must respond to the likeness of shape between the blocks and their corresponding holes. In picture completion, he must see what addition stands in the most significant relationship to the total picture situation. In telling how certain things are alike or different, he obviously responds to relationships; and so also in distinguishing between good and poor reasons for a certain fact. This element of response to relationships occurs again and again in the tests, though perhaps not in the simplest, such as naming familiar objects.

Besides these two intellectual factors in intelligent behavior, there are certain moral or impulsive factors. One is *persistence*, which is probably the same thing as the mastery or self-assertive instinct. The individual who gives up easily, or succumbs easily to distraction or timidity, is at a disadvantage in the tests or in any situation calling for intelligent behavior.

But, as we said before, in discussing the instincts, excessive stubbornness is a handicap in meeting a novel situation, which often cannot be mastered by the first mode of response that one makes to it. Some giving up, some *submissiveness* in detail along with persistence in the main effort, is needed. The too stubborn young child may waste a lot of time trying with all his might to force the square block into the round hole, and so make a poorer score in the test, than if he had given up his first line of attack and tried something else. Intelligent behavior must perforce

often have something of the character of "trial and error", and trial and error requires both persistence in the main enterprise and a giving up here in order to try again there.

Finally, the instinct of *curiosity* or exploration is evidently a factor in intelligence. The individual who is stimulated by novel things to explore and manipulate them will amass knowledge and skill that can later be utilized in the tests, or in intelligent behavior generally.

SPECIAL APTITUDES

We distinguish between the general factors in intelligence, just mentioned, and special aptitudes for dealing with colors, forms, numbers, weights etc. A special aptitude is a specific responsiveness to a certain kind of stimulus or object. The special aptitudes are factors in intelligent behavior—as we may judge from the content of the intelligence tests—only, the tests are so contrived as not to depend too much on any one or any few of the special aptitudes. Arithmetical problems alone would not make a fair test for intelligence, since they would lay undue stress on the special aptitude for number; but it is fair enough to include them along with color naming, weight judging, form copying, and word remembering, and so to give many special aptitudes a chance to figure in the final score.

There are tests in existence for some special aptitudes: tests for color sense and color matching, for musical ability, for ability in drawing, etc.; but as yet we have no satisfactory list of the special aptitudes. They come to light when we compare one individual with another, or one species with another. Thus, while man is far superior to the dog in dealing with colors, the dog is superior in dealing with odors. Man has more aptitude for form, but some animals are fully his equal in sense of location and ability to find

their way. Man is far superior in dealing with numbers and also with tools and mechanical things. He is superior in speech, in sense of rhythm, in sense of humor, in sense of pathos. Individual human beings also differ markedly in each of these respects. They differ in these special directions as well as in the "general factors" of intelligence.

HEREDITY OF INTELLIGENCE AND OF SPECIAL APTITUDES

Let us now return to the question raised at the very outset of the chapter, whether or not intelligence is a native trait. We then said that the differing intelligence of different species of animals must be laid to their native constitutions, but left the question open whether the differing intelligence of human individuals was a matter of heredity or of environment.

Intelligence is of course quite different from instinct, in that it does not consist in ready-made native reactions. The intelligence of an individual at any age depends on what he has learned previously. But the factors in intelligent behavior—retentiveness, responsiveness to relationships, persistence, etc.—may very well be native traits.

But what *evidence* is there that the individual's degree of intelligence is a native characteristic, like his height or color of hair? The evidence is pretty convincing to most psychologists.

First, we have the fact that an individual's degree of intelligence is an inherent characteristic, in the sense that it remains with him from childhood to old age. Bright child, bright adult; dull child, dull adult. That is the rule, and the exceptions are not numerous enough to shake it. Many a dull child of well-to-do parents, in spite of great pains taken with his education, is unable to escape from his inherent limitations. The intelligence quotient remains fairly

constant for the same child as he grows up, and stands for an inherent characteristic of the individual, namely, the rate at which he acquires knowledge and skill. Give two children the same environment, physical and social, and you will see one child progress faster than the other. Thus, among children who grow up in the same community, playing together and going to the same schools, the more rapid mental advance of some than of others is due to differences in native constitution, and the IQ gives a measure of the native constitution in this respect. There are exceptions, to be sure, depending on physical handicaps such as deafness or disease, or on very bad treatment at home, but in general the IQ can be accepted as representing a fact of native constitution.

Another line of evidence for the importance of native constitution in determining degrees of intelligence comes from the study of mental resemblance among members of the same family. Brothers or sisters test more alike than children taken at random from a community, and twins test more alike than ordinary brothers and sisters. Now, as the physical resemblance of brothers or sisters, and specially of twins, is accepted as due to native constitution, we must logically draw the same conclusion from their mental resemblance.

The way feeble-mindedness runs in families is a case in point. Though, in exceptional instances, mental defect arises from brain injury at the time of birth, or from disease (such as cerebrospinal meningitis) during early childhood, in general it cannot be traced to such accidents, but is inherent in the individual. Usually mental defect or some similar condition can be found elsewhere in the family of the mentally defective child; it is in the family stock. When both parents are of normal intelligence and come from families with no mental abnormality in any ancestral line, it is practically unknown that they should have a feeble-minded

child; but if mental deficiency has occurred in some of the ancestral lines, an occasional feeble-minded child may be born even of parents who are themselves both normal. If one parent is normal and the other feeble-minded, some of the children are likely to be normal and others feeble-minded; but if both parents are feeble-minded, it is said that all the children are sure to be feeble-minded or at least dull.

These facts regarding the occurrence of feeble-mindedness cannot be accounted for by environmental influences, especially the fact that some children of the same family may be definitely feeble-minded and others normal. We must remember that children of the same parents need not have precisely similar native constitutions; they are not always alike in physical traits such as hair color or eye color that are certainly determined by native constitution.

The special aptitudes also run in families. You find musical families where most of the children take readily to music, and other families where the children respond scarcely at all to music, though their general intelligence is good enough. You find a special liking and gift for mathematics cropping out here and there in different generations of the same family. No less significant is the fact that children of the same family show ineradicable differences from one another in such abilities. In one family were two brothers, the older of whom showed much musical ability and came early to be an organist and composer of church music; while the younger, possessing considerable ability in scholarship and literature, was never able to learn to sing or tell one tune from another. Being a clergyman, he desired very much to be able to lead in singing, but he simply could not learn. Such obstinate differences, persisting in spite of the same home environment, must depend on native constitution.

Native constitution determines mental ability in two respects. It fixes certain limits which the individual cannot

pass, no matter how good his environment, and no matter how hard he trains himself; and, on the positive side, it makes the individual responsive to certain stimuli, and so gives him a start towards the development of intelligence and of special aptitudes.

INTELLIGENCE AND THE BRAIN

There is certainly some connection between the brain and intelligent behavior. While the spinal cord and brain stem vary according to the size of the body, and the cerebellum with the motility of the species of animal, the size of the cerebrum varies more or less closely with the intelligence of the species. It does vary also with bodily size, as illustrated by the whale and elephant, which have the largest cerebrum of all animals, including man. But the monkey, which shows more intelligence than most animals, has also a very large cerebrum for his size of body; and the chimpanzee and gorilla, considerably surpassing the ordinary monkeys in intelligence, have also a much larger cerebrum. The cerebrum of man, in proportion to the size of his body, far surpasses that of the chimpanzee or gorilla.

The cerebrum varies considerably in size from one human individual to another. In some adults it is twice as large as in others, and the question arises whether greater intelligence goes with a larger brain. Now, it appears that an extremely small cerebrum spells idiocy; not all idiots have small brains, but all men with extremely small brains are idiots. The brain weight of quite a number of highly gifted men has been measured in post-mortem examination, and many of these gifted men have had a very large cerebrum. On the whole, the gifted individual seems to have a large brain, but there are exceptions, and the relationship between brain size and intelligence cannot be very close. Other factors must enter, one factor being undoubtedly the fineness

of the internal structure of the cortex. Brain function depends on dendrites and end-brushes, forming synapses in the cortex, and such minute structures make little impression on the total brain weight.

While intelligence is related to the cerebrum as a whole, rather than to any particular "intelligence center", there is some likelihood that the special aptitudes are related to special parts of the cortex, though it must be admitted that few aptitudes have as yet been localized. The pretended localizations of phrenology are all wrong. But we do know that each sense has its special cortical area, and that adjacent to these sensory areas are portions of the cortex intimately concerned in response to different classes of complex stimuli. Near the auditory center the cortex is concerned in recognizing spoken words, and in following music; near the visual center it is concerned in recognizing printed words, in recognizing seen objects, in finding one's way by the sense of sight, etc. These special aptitudes thus have a fairly definite cortical localization, and possibly others have also.

Examined microscopically, the cortex shows differences of structure in different parts, and to the structural differences probably correspond differences of function. Now it is practically impossible that such a function as attention or memory should have any localized cortical center, for these are general functions. The instincts are specialized enough to have local centers, but none have so far been localized. What has been localized is of the nature of special aptitudes.

EXERCISES

1. Outline the chapter.
2. Pick out the true statements from the following list:
 - (a) Man is the most intelligent of animals.
 - (b) Intelligence depends on the development of the cerebellum.
 - (c) It has not been found possible to use any single performance as a reliable index of intelligence.
 - (d) Children of different mental ages may have the same IQ.
 - (e) A child with a mental age of 10 years can do all the tests for 10 years and below, but none of those for the higher ages.
 - (f) The intelligence tests depend wholly on accurate response and not at all on speed of reaction.
 - (g) If intelligence tests depended upon previous training, they could not be measures of native intelligence.
 - (h) High correlation between the test scores of brothers and sisters is a fact that tends to indicate the importance of heredity in determining intelligence.
 - (i) The "general factors" in intelligence are the same as the instincts.
 - (j) Feeble-minded individuals include all those who are below the average intelligence.
3. It is found that eminent men very often have eminent brothers, uncles and cousins. How would this fact be explained?
4. It is also found that the wives of eminent men often have eminent relatives. How would this fact be explained?
5. How could it happen that a boy of 9, in the third school grade, with an IQ of 140, should be mischievous and inattentive? What should be done with him?
6. If a boy of 12, by industrious work, does pretty well in the fourth grade, why should we not accept the teacher's estimate of him as a "fairly bright boy"?
7. How might the brain of an idiot be underdeveloped, aside from the matter of the number of nerve cells in the cortex?
8. Can it be that high intelligence is a disadvantage in any form of industrial work, and, if so, how?
9. Show how "general intelligence" and "special aptitudes" may work together to give success in some special line of work.

REFERENCES

For the Binet tests and some results obtained by their use, see Louis M. Terman, *The Measurement of Intelligence*, 1916.

The group tests used in the American Army during the War are described in detail in Vol. 15 of the *Memoirs of the National Academy of Sciences*, 1921, edited by Robert M. Yerkes. This large book describes the work of preparing and standardizing the tests, and also gives some results bearing on the intelligence of different sections of the population. Some of the interesting results appear on pp. 507, 522, 528, 537, 693, 697, 705, 732, 743, 799, 815, 819, 829, 856 and 869.

For briefer treatments of the subject, see Walter S. Hunter's *General Psychology*, 1919, pp. 36-53, and W. B. Pillsbury's *Essentials of Psychology*, 2nd edition, 1920, pp. 388-407.

For the poor results obtained in attempting to judge intelligence from photographs, see an illustrated article by Rudolph Pintner, in the *Psychological Review* for 1918, Vol. 25, pp. 286-296.

For a study of one of the special aptitudes, see C. E. Seashore's *Psychology of Musical Talent*, 1919.

For a comprehensive survey of test methods and results, see the two volumes of Whipple's *Manual of Mental and Physical Tests*, 2nd edition, 1914, 1915.

CHAPTER XIII

LEARNING AND HABIT FORMATION

THE DEPENDENCE OF ACQUIRED REACTIONS UPON INSTINCT AND REFLEX ACTION, AND THE MODIFICATION OF NATIVE REACTIONS BY EXPERIENCE AND TRAINING.

Already, in considering intelligence, we have partially rounded the corner from native to acquired traits, and now, fairly around the corner, we see ahead of us a long straight stretch of road. For there is much to say regarding acquired traits and regarding the process of acquisition. All knowledge is acquired, the whole stock of ideas, as well as motor skill, and there are acquired motives in addition to the native motive forces that we called instincts, and acquired likes and dislikes in addition to those that are native; so that, all in all, there are thousands on thousands of acquired reactions, and the daily life of the adult is made up of these much more than of strictly native reactions.

It will take us several chapters to explore this new territory that now lies before us, a chapter on acquiring motor habits and skill, a chapter on memory, a chapter on acquired mental reactions, and a chapter devoted to the general laws that hold good in this whole field. Our general plan is to proceed from the simple to the complex, generalizing to some extent as we go, but leaving the big generalizations to the close of the discussion, where we shall see whether the whole process of acquiring reactions of all sorts cannot be summed up in a few general laws of acquisition, or "laws of association" as they are traditionally called. On reaching that

goal, the reader may well come back, with the general laws in mind, and see how well they fit in detail all the instances of acquired responses that we are about to describe. We might have begun by stating the general laws, but on the whole it will be better to proceed "inductively", beginning with the observed facts and working up to the general laws.

ACQUIRED REACTIONS ARE MODIFIED NATIVE REACTIONS

Though we have "turned a corner" in passing from native traits to acquired, it would be a mistake to suppose we had left what is native altogether behind. It would be a mistake to suppose that the individual outgrew and left behind his native reactions and acquired an entirely new outfit. The reactions that he acquires—or *learns*, as we speak of acquisition in the sphere of reactions—develop out of his native reactions. Consider this: how is the individual ever going to learn a reaction? Only by reacting. Without native reactions, he would be entirely inactive at the outset, and would never make a start towards any acquisition. His acquired reactions, then, are his native reactions modified by use.

The vast number of motor acts that the individual acquires are based upon the reflexes. They are modified reflexes. The simplest kind of modification is the mere *strengthening* of an act by exercise. By his reflex breathing and crying, the new-born baby exercises his lungs and breathing muscles and the nerve centers that control them, with the result that his breathing becomes more vigorous, his crying louder. The strengthening of a reaction through exercise is a fundamental fact.

But we should scarcely speak of "learning" if the only modification consisted in the simple strengthening of native reactions, and at first thought it is difficult to see how the

exercise of any reaction could modify it in any other respect. But many reflexes are not perfectly fixed and invariable, but allow of some free play, and then exercise may fix or stabilize them, as is well illustrated in the case of the pecking response of the newly hatched chick. If grains are strewn before a chick one day old, it instinctively strikes at them, seizes them in its bill and swallows them; but, its aim being poor and uncertain, it actually gets, at first, only a fifth of the grains pecked at; by exercise it improves so as to get over half on the next day, over three-fourths after another day or two, and about 85 percent (which seems to be its limit) after about ten days of practice. Exercise has here modified a native reaction in the way of making it more definite and precise, by strengthening the accurate movement as against all the variations of the pecking movement that were made at the start. Where a native response is variable, exercise tends towards constancy, and so towards the *fixation* of definite habits.

A reflex may come to be *attached* to a new stimulus, that does not naturally arouse it. A child who has accidentally been pricked with a pin, and of course made the flexion reflex in response to this natural stimulus, will make this same reaction to the sight of a pin approaching his skin. The seen pin is a *substitute stimulus* that calls out the same response as the pin prick. This type of modification gives a measure of control over the reflexes; for when we pull the hand back voluntarily, or wink at will, or breathe deeply at will, we are executing these movements without the natural stimulus being present.

Voluntary control includes also the ability to omit a response even if the natural stimulus is present. Holding the breath, keeping the eyes wide open in spite of the tendency to wink, not swallowing though the mouth is full of saliva, holding the hand steady when it is being pricked, and many

similar instances of control over reflexes are cases of *detachment* of a native reaction from its natural stimulus. Not "starting" at a sudden sound to which we have grown used and not turning the eyes to look at a very familiar object, are other instances of this detachment.

The *substitute response* is another modification to be placed alongside of the substitute stimulus. Here a natural stimulus calls out a motor response different from its natural response. The muttered imprecation of the adult takes the place of the child's scream of pain. The loose holding of the pen between the thumb and the first two fingers takes the place of the child's full-fisted grasp.

Finally, an important type of modification consists in the *combination* of reflex movements into larger coördinations. One hand grasps an object, while the other hand pulls, pushes or strikes it. Or, both hands grasp the object but in different ways, as in handling an ax or shovel. These cases illustrate simultaneous coördination, and there is also a serial coördination, in which a number of simple instinctive movements become hitched together in a fixed order. Examples of this are seen in dancing, writing a word, and, most notably, in speaking a word or familiar phrase.

In these ways, by strengthening, fixing and combining movements, and by new attachments and detachments between stimulus and response, the instinctive motor activity of the baby passes over into the skilled and habitual movement of the adult.

ACQUIRED TENDENCIES

In the sphere of *impulse* and *emotion*, the same kinds of modification occur. Detachment of an impulse or emotion from its natural stimulus is very much in evidence, since

what frightens or angers or amuses the little child may have no such power with the adult. One little boy of two could be thrown into gales of laughter by letting a spoon drop with a bang to the floor; and you could repeat this a dozen times in quick succession and get the response every time. But this stimulus no longer worked when he had advanced to the age of four.

The emotions get attached to substitute stimuli. Amusement can be aroused in an older child by situations that were not at all amusing to the baby. New objects arouse fear, anger, rivalry or curiosity. The emotions of the adult—with the exception of sex attraction, which is usually very weak in the child—are the emotions of the child, but they are aroused by different stimuli.

Not only so, but the emotions express themselves differently in the child and the adult. Angry behavior is one thing in the child, and another thing in the adult, so far as concerns external motor action. The child kicks and screams, where the adult strikes with his fist, or vituperates, or plots revenge. The internal bodily changes in emotion are little modified as the individual grows up—except that different stimuli arouse them—but the overt behavior is greatly modified; instead of the native reactions we find substitute reactions.

A little girl of three years, while out walking in the woods with her family, was piqued by some correction from her mother, but, instead of showing the instinctive signs of temper, she picked up a red autumn leaf and offered it to her mother, with the words, very sweetly spoken, "Isn't that a pretty leaf?" "Yes," said her mother, acquiescently. "Wouldn't you like to have that leaf?" "Yes, indeed." "I'll throw it away!" (in a savage tone of voice, and with a gesture throwing the leaf away). Here we have an early form of substitute reaction, and can glimpse how such re-

actions become attached to the emotions. The natural outlet for the child's anger was blocked, probably because previous outbursts of rage had not had satisfactory consequences, so that the anger was dammed up, or "bottled up", for the instant, till the child found some act that would give it vent. Now supposing that the substitute reaction gave satisfaction to the child, we can well imagine that it would become attached to the angry state and be used again in a similar case. Thus, without outgrowing the emotions, we may outgrow emotional behavior that is socially unacceptable.

Emotions are also combined, much as reflexes are combined. The same object which on one occasion arouses in us one emotion may arouse another emotion on another occasion, so that eventually, whenever we see that object, we respond by a blend of the two emotions. Your chief may terrify you on some occasions, at other times amaze you by his masterly grasp on affairs, and again win your affection by his care for your own welfare; so that your attitude toward "the boss" comes to be a blend of fear, admiration and gratitude. Religion and patriotism furnish good examples of compound emotions.

Well, then, adult behavior compared with the instinctive behavior of the little child shows these several types of modification. This is interesting, but it is not all we wish to know. We want to know how the modification comes about; that is, we want to get an insight into the *process* of learning. Scientifically, this is one of the most fascinating topics in psychology—how we learn, how we are molded or modified by experience—and practically, it is just as important, since if we wish to educate, train, mold, improve ourselves or others, it is the *process* of modification that we must control; and to control it we must understand it.

To understand it we must watch the process itself; and

therefore we turn to studies that trace the course of events in human and animal learning.

ANIMAL LEARNING

Animals do learn, all the vertebrates, at least, and many of the invertebrates. They often learn more slowly than men, but this is an advantage for our present purpose, since it makes the learning process easier to follow. Mere anecdotes of intelligent behavior in animals are of little value, but experimental studies, in which the animal's progress is followed, step by step, from the time when he is confronted with a perfectly novel situation till he has mastered the trick, have now been made in great numbers, and a few typical experiments will serve as a good introduction to the whole subject of learning.

The negative adaptation experiment. Apply a harmless and meaningless stimulus time after time; at first the animal makes some instinctive exploring or defensive reaction; but with continued repetition of the stimulus, he ceases after a while to respond. The instinctive reaction has been detached from one of its natural stimuli.

Even in unicellular animals, negative adaptation can be observed, but in them is only temporary, like the "sensory adaptation" described in the chapter on sensation. Stop the stimulus and the original responsiveness returns after a short time. Nothing has been learned, for what is learned remains after an interval of rest.

In higher animals, permanent adaptation is common, as illustrated by a famous experiment on a spider. While the spider was in its web, a tuning fork was sounded, and the spider made the defensive reaction of dropping to the ground. It climbed back to its web, the fork was sounded again, the spider dropped again; but after several repeti-

tions in quick succession, the spider ceased to respond. Next day, to be sure, it responded as at first; but after the same performance had been repeated on several days, it ceased permanently to respond to this stimulus.

/- Negative adaptation is common in domestic animals, as well as in men. The horse "gets used" to the harness, and the dog to the presence of a cat in the house. Man grows accustomed to his surroundings, and to numerous unimportant sights and sounds.

The conditioned reflex experiment. Put into a dog's mouth a tasting substance that arouses the flow of saliva, and at the same instant ring a bell; and repeat this combination of stimuli many times. Then ring the bell alone, and the saliva flows in response to the bell. The bell is a *substitute stimulus*, which has become attached to the salivary response by dint of having been often given along with the natural stimulus that arouses this response. At first thought, this is very weird, but do we not know of similar facts in every-day experience? The dinner bell makes the mouth water; the sight of food does the same, even the name of a savory dish will do the same.

Quite possibly, the learning process by which the substitute stimulus becomes attached to the salivary reaction is more complex in man's case. He may *observe* that the dinner bell means dinner, whereas the dog, we suppose, does not definitely observe the connection of the bell and the tasting substance. What the experiment shows is that a substitute stimulus can become attached to a reaction under very simple conditions.

A conditioned reflex experiment on a child deserves mention. A young child, confronted with a rabbit, showed no fear, but on the contrary reached out his hand to take the rabbit. At this instant a loud rasping noise was produced just behind the child, who quickly withdrew his hand with

signs of fear. After this had been repeated a few times, the child shrank from the rabbit and was evidently afraid of it. Probably it is in this way that many fears, likes and dislikes of children originate.

The signal experiment. Place a white rat before two little doors, both just alike except that one has on it a yellow circle. The rat begins to explore. If he enters the door with the yellow sign, he finds himself in a passage which leads to a box of food; if he enters the other door he gets into a blind alley, which he explores, and then, coming out, continues his explorations till he reaches the food box and is rewarded. After this first trial is thus completed, place him back at the starting point, and he is very apt to go straight to the door that previously led to the food, for he learns simple locations very quickly. But meanwhile the experimenter may have shifted the yellow sign to the other door, connected the passage behind the marked door with the food box, and closed off the other passage; for the yellow disc in this experiment always marks the way to the food, and the other door always leads to a blind alley. The sign is shifted irregularly from one door to the other. Whenever the rat finds himself in a blind alley, he comes out and enters the other door, so finally getting his reward on every trial. But for a long time he seems incapable of responding to the yellow signal. However, the experimenter is patient; he gives the rat twenty trials a day, keeping count of the number of correct responses, and finds the number to increase little by little, till after some thirty days every response is correct and unhesitating. The rat has learned the trick.

He learns the trick somewhat more rapidly if punishment for incorrect responses is added to reward for correct responses. Place wires along the floor of the two passages, and switch an electric current into the blind alley, behind

the door that has no yellow circle on it. When the rat enters the blind alley and gets a shock, he makes a prompt avoiding reaction, scampering back to the starting point and cowering there for some time; eventually he makes a fresh start, avoids the door that led to the shock and therefore enters the other door, though apparently without paying any attention to the yellow sign, since when, on the next trial, the sign is moved, he avoids the *place* where he got the shock, without reference to the sign. But in a series of trials he learns to follow the sign.

Learning to respond to a signal might be classified under the head of substitute stimulus, since the rat learns to respond to a stimulus, the yellow disk, that at first left him unmoved. But more careful consideration shows this to be, rather, a case of substitute response. The natural reaction of a rat to a door is to enter it, not to look at its surface, but the experiment forces him to make the preliminary response of attending to the appearance of the door before entering it. The response of attending to the surface of the door is substituted for the instinctive response of entering. Otherwise put: the response of finding the marked door and entering that is substituted for the response of entering any door at random.

The maze experiment. An animal is placed in an enclosure from which it can reach food by following a more or less complicated path. The rat is the favorite subject for this experiment, but it is a very adaptable type of experiment and can be tried on any animal. Fishes and even crabs have mastered simple mazes, and in fact to learn the way to a goal is probably possible for any species that has any power of learning whatever. The rat, placed in a maze, explores. He sniffs about, goes back and forth, enters every passage, and actually covers every square inch of the maze at least once; and in the course of these explorations

hits upon the food box. Replaced at the starting point, he proceeds as before, though with more speed and less dallying in the blind alleys. On successive trials he goes less and less deeply into a blind alley, till finally he passes the entrance to it without even turning his head. Thus eliminating the

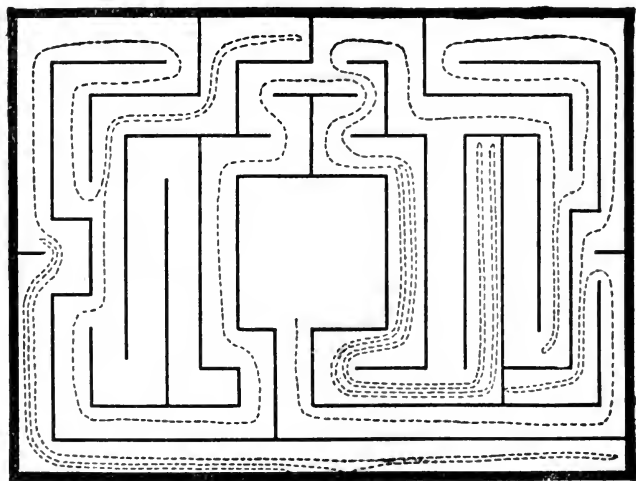

Entrance

FIG. 47.—(From Hicks.) Ground plan of a maze used in experiments on the rat. The central square enclosure is the food box. The dotted line shows the path taken by a rat on its fourth trial, which occupied 4 minutes and 2 seconds.

blind alleys one after another, he comes at length to run by a fixed route from start to finish.

At first thought, the elimination of useless moves seems to tell the whole story of the rat's learning process; but careful study of his behavior reveals another factor. When the rat approaches a turning point in the maze, his course bends so as to prepare for the turn; he does not simply advance to the turning point and then make the turn, but several steps before he reaches that point are organized or coördinated into a sort of unit.

The combination of steps into larger units is shown also by certain variations of the experiment. It is known that the rat makes little use of the sense of sight in learning the maze, guiding himself mostly by the muscle sense. Now if

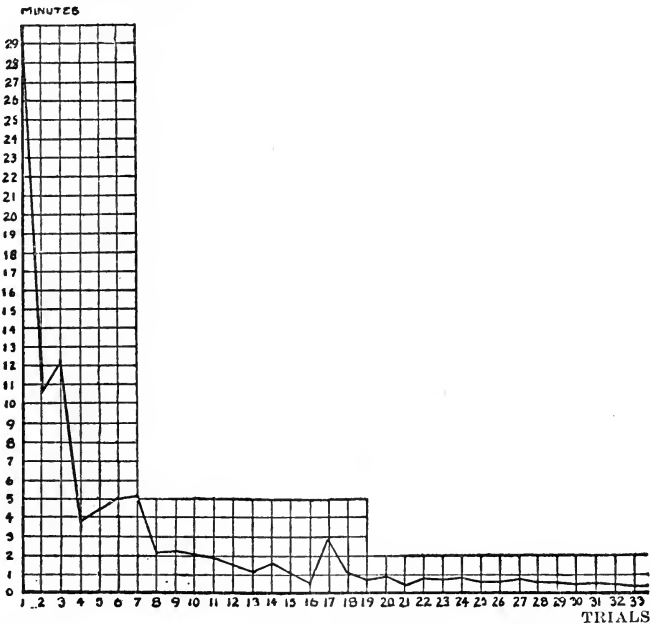

FIG. 48.—(From Watson.) Learning curve for the rat in the maze. This is a composite or average, derived from the records of four animals. The height of the heavy line above the base line, for any trial, indicates the number of minutes consumed in that trial in passing through the maze and reaching the food box. The gradual descent of the curve indicates the gradual decrease in time required, and thus pictures the progress of the animals in learning the maze.

the maze, after being well learned, is altered by shortening one of the straight passages, the rat runs full tilt against the new end of the passage, showing clearly that he was proceeding, not step by step, but by *runs* of some length. Another variation of the experiment is to place a rat that has learned a maze down in the midst of it, instead of at

the usual starting point. At first he is lost, and begins exploring, but, hitting on a section of the right path, he gets his cue from the "feel" of it, and races off at full speed to the food box. Now his cue could not have been any single step or turn, for these would all be too much alike; his cue must have been a familiar *sequence* of movements, and that sequence functions as a unit in calling out the rest of the habitual movement.

In short, the rat learns the path by *elimination* of false

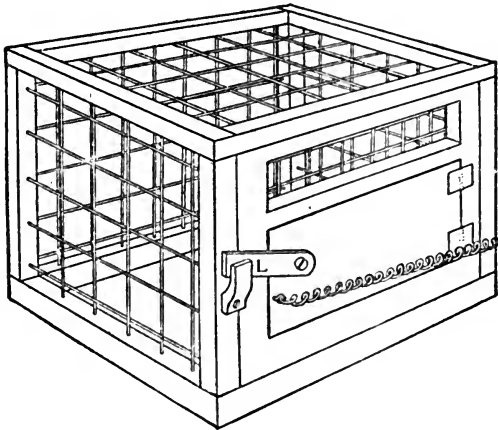

FIG. 49.—(From Watson.) A puzzle box. The animal must here reach his paw out between the bars and raise the latch, *L*. A spring then gently opens the door.

reactions and by *combination* of single steps and turns into larger reaction-units.

The puzzle-box experiment. Place a hungry young cat in a strange cage, with a bit of fish lying just outside, and you are sure to get action. The cat extends his paw between the slats but cannot reach the fish; he pushes his nose between the slats but cannot get through; he bites the slats, claws at anything small, shakes anything loose, and tries every part of the cage. Coming to the button that fastens

the door, he attacks that also, and sooner or later turns the button, gets out, and eats the fish. The experimenter, having noted the time occupied in this first trial, replaces the cat, still hungry, in the cage, and another bit of fish outside. Same business, but perhaps somewhat quicker escape. More trials, perhaps on a series of days, give gradually decreasing times of escape. The useless reactions are gradually eliminated, till finally the cat, on being placed in the cage, goes instantly to the door, turns the button, goes out and starts to eat, requiring but a second or two for the whole complex reaction. Perhaps 15 or 20 trials have been required to reach this stage of prompt, unerring response. The course of improvement is rather irregular, with ups and downs, but with no sudden shift from the varied reaction of the first trial to the fixed reaction of the last. The learning process has been gradual.

This is the typical instance of learning by "trial and error", which can be defined as varied reaction with gradual elimination of the unsuccessful responses and fixation of the successful one. It is also a case of the substitute response. At first, the cat responds to the situation by reaching or pushing straight towards the food, but it learns to substitute for this most instinctive response the less direct response of going to another part of the cage and turning a button.

The cat in this experiment is evidently trying to get out of the cage and reach the food. The situation of being confined in a cage while hungry arouses an impulse or tendency to get out; but this tendency, unable at once to reach its goal, is dammed up, and remains as an inner directive force, facilitating reactions that are in the line of escape and inhibiting other reactions. When the successful response is hit upon, and the door opened, the dammed-up energy is discharged into this response; and, by repetition,

the successful response becomes closely attached to the escape-tendency, so as to occur promptly whenever the tendency is aroused.

There is no evidence that the cat reasons his way out of the cage. His behavior is impulsive, not deliberative. There is not even any evidence that the cat clearly observes how he gets out. If he made a clean-cut observation of the manner of escape, his time for escaping should thereupon take a sudden drop, instead of falling off gradually and irregularly from trial to trial, as it does fall off. Trial and error learning is learning by doing, and not by reasoning or observing. The cat learns to get out by getting out, not by seeing how to get out.

SUMMARY OF ANIMAL LEARNING

Let us take account of stock at this point, before passing to human learning, and attempt to generalize what we have observed in animals of the process of learning.

(1) *Elimination* of a response, which means *detachment* of a response from the stimulus that originally aroused it, occurs in three main cases:

(a) Elimination occurs most quickly when the response brings actual *pain*; the animal makes the avoiding reaction to the pain and quickly comes to make this response to the place where the pain occurred; and thus the positive reaction to this place is eliminated.

(b) Elimination occurs more gradually when the response, without resulting in actual pain, brings *failure* or *delay* in reaching a goal towards which the animal is tending. The positive response of entering and exploring a blind alley grows weaker and weaker, till the blind alley is neglected altogether.

(c) Elimination of a response also occurs, slowly, through *negative adaptation* to a stimulus that is harmless and also useless.

(2) New *attachments* or *linkages*¹ of stimulus and response occur in two forms, which are called "substitute stimulus" and "substitute response".

(a) *Substitute stimulus* refers to the case where the natural response is not itself modified, but becomes attached to another stimulus than the one that originally aroused it. This new linkage can sometimes be established by simply giving the original stimulus and the substitute stimulus at the same time, and doing so repeatedly, as in the conditioned reflex experiment.

(b) *Substitute response* refers to the case where, the stimulus remaining as it originally was, a new reaction is attached to it in place of the original response. The conditions under which this takes place are more complex than those that give the substitute stimulus. A tendency towards some goal must first be aroused, and then blocked by the failure of the original response to lead to the goal. The dammed-up tendency then facilitates other responses, and gives trial and error behavior, till some one of the trial responses leads to the goal; and this successful response is gradually substituted for the original response, and becomes firmly attached to the situation and tendency.

(3) New *combinations of responses* occur, giving higher motor units.

HUMAN LEARNING

To compare human and animal learning, and notice in what ways the human is superior, cannot but throw light on the whole problem of the process of learning. It is obvious

¹ The writer hopes that no confusion will be caused by his use of several words to express this same meaning. "Attachment of stimulus and response", "linkage of stimulus and response", "connection between stimulus and response", and "bond between stimulus and response", all mean exactly the same; but sometimes one and sometimes another seems to bring the meaning more vividly to mind.

that man learns more quickly than the animals, that he acquires more numerous reactions, and a much greater variety of reactions; but the important question is how he does this, and how his learning process is superior.

We must first notice that all the forms of learning displayed by the animal are present also in the human being. (Negative adaptation is important in human life, and the conditioned reflex is important, as has already been suggested. Without negative adaptation, the adult would be compelled to attend to everything that aroused the child's curiosity, to shrink from everything that frightened the child, to laugh at everything that amused the child. The conditioned reflex type of learning accounts for a host of acquired likes and dislikes. Why does the adult feel disgust at the mere sight of the garbage pail or the mere name of cod liver oil? Because these inoffensive visual and auditory stimuli have been associated, or paired, with odors and tastes that naturally aroused disgust.

The signal experiment is duplicated thousands of times in the education of every human being. He learns the meaning of signs and slight indications; that is, he learns to recognize important facts by aid of signs that are of themselves unimportant. We shall have much to say on this matter in a later chapter on perception. Man learns signs more readily than such an animal as the rat, in part because the human being is naturally more responsive to visual and auditory stimuli. Yet the human being often has trouble in learning to read the signs aright. He assumes that a bright morning means good weather all day, till, often disappointed, he learns to take account of less obvious signs of the weather. Corrected for saying, "You and me did it", he adopts the plan of always saying "you and I", but finds that this quite unaccountably brings ridicule on him at times, so that gradually he *may* come to say the one or the

other according to obscure signs furnished by the structure of the particular sentence. The process of learning to respond to obscure signs seems to be about as follows: something goes wrong, the individual is brought to a halt by the bad results of his action, he then sees some element in the situation that he had previously overlooked, responds to this element, gets good results, and so—perhaps after a long series of trials—comes finally to govern his action by what seemed at first utterly insignificant.

Trial and error learning, though often spoken of as characteristically “animal”, is common enough in human beings. Man learns by impulsively doing in some instances, by rational analysis in others. He would be at a decided disadvantage if he could not learn by trial and error, since often the thing he has to manage is very difficult of rational analysis. Much motor skill, as in driving a nail, is acquired by “doing the best you can”, getting into trouble, varying your procedure, and gradually “getting the hang of the thing”, without ever clearly seeing what are the conditions of success.

HUMAN COMPARED WITH ANIMAL LEARNING

Fairly direct comparisons have been made between human and animal learning of mazes and puzzles. In the maze, the human subject has an initial advantage from knowing he is in a maze and has to master it, while the rat knows no more than that he is in a strange place, to be explored with caution on the odd chance that it may contain something eatable, or something dangerous. But, after once reaching the food box, the rat begins to put on speed in his movements, and within a few trials is racing through the maze faster than the adult man, though not so fast as a child. Adults are more circumspect and dignified, they make less speed, cover less distance, but also make fewer false moves

and finish in less time. That is in the early trials; adults do not hold their advantage long, since children and even rats also reach complete mastery of a simple maze in ten or fifteen trials.

The chief point of superiority of adults to human children, and of these to animals, can be seen in the adjacent table. It is in the *first trial* that the superiority of the adults shows most clearly. They get a better start, and adapt themselves to the situation more promptly. Their better start is due to (1) better understanding of the situation at the outset, (2) more plan, (3) less tendency to "go off on a tangent", i.e., to respond impulsively to every opening, without considering or looking ahead. The adult has more inhibition, the child more activity and responsiveness; the adult's inhibition stands him in good stead at the outset, but the child's activity enables him to catch up shortly in so simple a problem as this little maze.

AVERAGE NUMBER OF ERRORS MADE, IN EACH TRIAL IN
LEARNING A MAZE, BY RATS, CHILDREN AND
ADULT MEN

(From Hicks and Carr)

Trial No.	Rats	Children	Adults
1	53	35	10
2	45	9	15
3	30	18	5
4	22	11	2
5	11	9	6
6	8	13	4
7	9	6	2
8	4	6	2
9	9	5	1
10	3	5	1
11	4	1	0
12	5	0	1
13	4	1	1
14	4	0	1
15	4	1	1
16	2	0	1
17	1	0	1

The table reads that, on the first trial in the maze, the rats averaged 53 errors, the children 35 errors, and the adults 10 errors, and so on. An "error" consisted in entering a blind alley or in turning back on

the course. The subjects tested consisted of 23 rats, five children varying in age from 8 to 13 years, and four graduate students of psychology. The human maze was much larger than those used for the rats, but roughly about the same in complexity. Since rats are known to make little use of their eyes in learning a maze, the human subjects were blindfolded. The rats were rewarded by food, the others simply by the satisfaction of success.

The puzzle boxes used in experiments on animal learning are too simple for human adults, but mechanical puzzles present problems of sufficient difficulty. The experimenter hands the subject a totally unfamiliar puzzle, and notes the time required by the subject to take it apart; and this is repeated in a series of trials till mastery is complete. In addition to taking the time, the experimenter observes the subject's way of reacting, and the subject endeavors at the end of each trial to record what he has himself observed of the course of events.

The human subject's behavior in his first trial with a puzzle is often quite of the trial and error sort. He manipulates impulsively; seeing a possible opening he responds to it, and meeting a check he backs off and tries something else. Often he tries the same line of attack time and time again, always failing; and his final success, in the first trial, is often accidental and mystifying to himself.

On the second trial, he may still be at a loss, and proceed as before; but usually he has noticed one or two facts that help him. He is most likely to have noticed *where* he was in the puzzle when his accidental success occurred; for it appears that locations are about the easiest facts to learn for men as well as animals. In the course of a few trials, also, the human subject notices that some lines of attack are useless, and therefore eliminates them. After a time he may "see into" the puzzle more or less clearly, though sometimes he gets a practical mastery of the handling of the puzzle, while still obliged to confess that he does not understand it at all.

Insight, when it does occur, is of great value. Insight into the general principle of the puzzle leads to a better general plan of attack, and insight into the detailed difficulties of manipulation leads to smoother and defter handling. The human "learning curve" (see Figure 50) often shows a prolonged stretch of no improvement, followed by an abrupt change to quicker work; and the subject's intro-

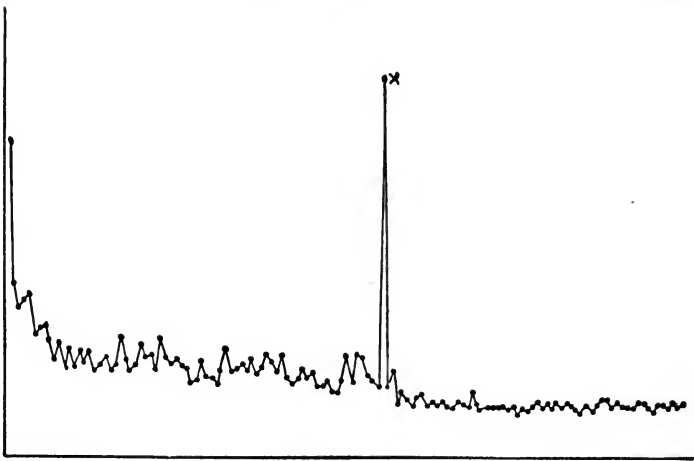

FIG. 50.—(From Ruger.) Curve for human learning of a mechanical puzzle. Distance above the base line represents the time occupied in each trial, the successive trials being arranged in order from left to right. A drop in the curve denotes a decrease in time, and thus an improvement. At X, the subject saw something about the puzzle that he had not noticed before and studied it out with some care, so increasing his time for this one trial, but bringing the time down thereafter to a new and steady level.

spectations show that 75 per cent. or more of these sudden improvements followed immediately after some fresh insight into the puzzle.

The value of insight appears in another way when the subject, after mastering one puzzle, is handed another involving the same principle in a changed form. If he has seen the principle of the first puzzle, he is likely to carry over this knowledge to the second, and master this readily;

but if he has simply acquired motor skill with the first puzzle, without any insight into its principle, he may have as hard a time with the second as if he had never seen the first.

LEARNING BY OBSERVATION

“We learn by doing” is a true proverb, in the sense that we acquire a reaction by making just that reaction. We *must* make a reaction in order to get it really in hand, so that the proverb might be strengthened to read, “To learn, we must do”. But we should make it false if we strengthened it still further and said “We learn *only* by doing”. For human beings, at least, learn also by observing.

The “insight” just spoken of consists in observing some fact—often some relationship—and the value of insight in hastening the process of learning is a proof that we learn by observation as well as by actual manipulation. To be sure, observation needs to be followed by manipulation in order to give practical mastery of a thing, but manipulation without observation means slow learning and often yields nothing that can be carried over to a different situation.

Learning by observation is typically human. The adult’s superiority in tackling a maze may be summed up by saying that he observes more than the child—much more than the animal—and governs his behavior by his observations. The enormous human superiority in learning a simple puzzle, of the sort used in experiments on animals, arises from seeing at once the key to the situation.

A chimpanzee—one of the most intelligent of animals—was tested with a simple puzzle box, to be opened from outside by turning a button that prevented the door from opening. The device was so simple that you would expect the animal to see into it at once. A banana was put into the box and the door fastened with the button. The chim-

panzee quickly found the door, and quickly found the button, which he proceeded to pull about with one hand while pulling the door with the other. Without much delay, he had the button turned and the door open. After about three trials, he had a practical mastery of the puzzle, showing thus considerable superiority over the cat, who would more likely have required twelve or fifteen trials to learn the trick. But now a second button was put on a few inches from the first, both being just alike and operating in the same way. The chimpanzee paid no attention to this second button, but turned the first one as before, and when the door failed to open, kept on turning the first button, opening it and closing it and always tugging at the door. After a time, he did shift to the second button, but as he had left the first one closed, his manipulation of the second was futile. It was a long, hard job for him to learn to operate both buttons correctly; and the experiment proved that he did not observe how the button kept the door from opening, but only that the button was the thing to work with in opening the door. At one time, indeed, in order to force him to deal with the second button, the first one was removed, but he still went to the place where it had been and fingered about there. What he had observed was chiefly the *place* to work at in order to open the door. We must grant that animals observe locations, but most of their learning is by doing and not by observing.

Here is another experiment designed to test the ability of animals to learn by observation. The experimenter takes two cats, one having mastered a certain puzzle box, the other not, and places the untrained cat where it can watch the trained one do its trick. The trained cat performs repeatedly for the other's benefit, and is then taken away and the untrained cat put into the puzzle box. But he has derived no benefit from what has gone on before his eyes, and must learn by trial

and error, the same as any other cat; he does not even learn any more quickly than he otherwise would have done.

The same negative results are obtained even with monkeys, but the chimpanzee shows some signs of learning by observation. One chimpanzee having learned to extract a banana from a long tube by pushing it out of the further end with a stick which the experimenter had kindly left close by, another chimpanzee was placed where he could watch the first one's performance and did watch it closely. Then the first animal was taken away and the second given a chance. He promptly took the stick and got the banana, without, however, imitating the action of the first animal exactly, but pulling the banana towards him till he could reach it. This has been called learning by imitation, but might better be described as learning by observation.

Such behavior, quite rare among animals, is common in human children, who are very observant of what older people do, and imitate them on the first opportunity, though often this comes after an interval. The first time a child speaks a new word is usually not right after he has heard it. When, on previous occasions, he has heard this word, he has not attempted to copy it, but now he brings it out of himself. He has not acquired the word by direct imitation, evidently, but by what has been called "delayed imitation", which consists in observation at the time followed later by attempts to do what has been observed. Observation does not altogether relieve the child of the necessity of learning by trial and error, for often his first imitations are pretty poor attempts; but observation gives him a good start and hastens the learning process considerably. "Learning by imitation", then, is, more properly, "learning by observation followed by trial and error", and the reason so little of it appears in animals is their lack of observation.

Learning by thinking depends on observation, since in

thought we make use of facts previously observed. Seldom, unless in the chimpanzee and other manlike apes, do we see an animal that appears to be thinking. The animal is always doing, or waiting, or sleeping. He seems too impulsive to stop and think. But a man may observe something in the present problem that calls previous observations to mind, and by mentally combining observations made at different times may figure out the solution before beginning motor manipulation. Usually, however, some manipulation of the trial and error sort is needed before the thought-out solution will work perfectly.

Sometimes mental rehearsal of a performance assists in learning it, as we see in the beginner at automobile driving, who, while lying in bed after his first day's experience, mentally goes through the motions of starting the engine and then the car, and finds that this "absent treatment" makes the car easier to manage the next day.

In summing up the points of superiority of human over animal learning, we may note that—

1. Man is perhaps a quicker learner, anyway, without regard to his better methods of learning. This, however, is open to doubt, in view of the very rapid learning by animals of such reactions as the avoidance of a place where they have been hurt.

2. Man is a better observer, and this is the great secret of his quick learning. He is especially strong in observing relationships, or "principles" as we often call them.

3. He has more control over his impulses, and so finds time and energy for observing and thinking.

4. He is able to work mentally with things that are not present; he remembers things he has seen, puts together facts observed at different times, thinks over problems that are not actually confronting him at the moment, and maps out plans of action.

THE LEARNING OF COMPLEX PRACTICAL PERFORMANCES

A great deal of light has been thrown on the learning process by psychological studies of the course of improvement in mastering such trades as telegraphy and typewriting.

A student of telegraphy was tested once a week to see how rapidly he could send a message, and also how rapidly he could "receive a message off the wire", by listening to the clicking of the sounder. The number of letters sent or received per minute was taken as the measure of his proficiency. This number increased rapidly in the first few

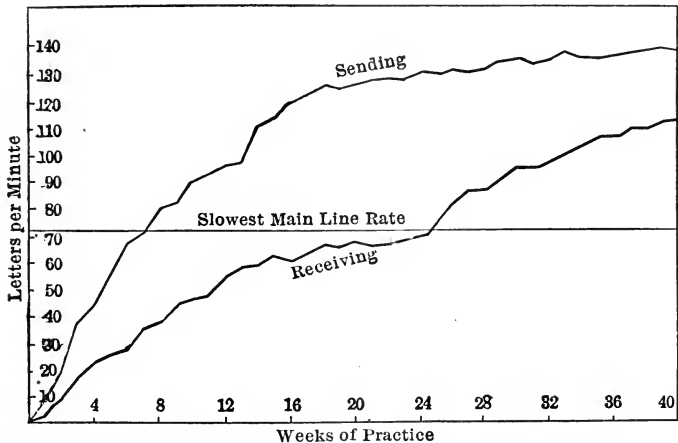

FIG. 51.—(From Bryan and Harter.) Practice curve of student W. J. R. in learning telegraphy. The height of the curve indicates the number of letters sent or received per minute. Therefore a rise of the curve here indicates improvement.

weeks, and then more and more slowly, giving a typical learning curve, or "practice curve", as it is also called.

The curve for sending, aside from minor irregularities, rose with a fairly smooth sweep, tapering off finally towards the "physiological limit", the limit of what the nerves and muscles of this individual could perform.¹ The receiving

¹ A good example of the physiological limit is seen in the hundred yard dash, since apparently no one, with the best of training, can lower

curve rose more slowly than the sending curve, and flattened out after about four months of practice, showing little further improvement for the next two months. This was a discouraging time for the student, for it seemed as if he could never come up to the commercial standard. In fact, many learners drop out at this stage. But this student persisted, and, after the long period of little improvement, was gratified to find his curve going up rapidly again. It went up rapidly for several months, and when it once more tapered off into a level, he was well above the minimum standard for regular employment.

Such a flat stretch in a practice curve, followed by a second rise—such a period of little or no improvement, followed by rapid improvement—is called a “plateau”. Sometimes due to mere discouragement, or to the inattention that naturally supervenes when an act becomes easy to perform, it often has a different cause. It may, in fact, represent a true physiological limit for the act as it is being performed, and the subsequent rise to a higher level may result from *improved methods* of work. That was probably the case with the telegrapher.¹

The telegrapher acquires skill by improving his methods, rather than by simply speeding up. He acquires methods that he didn't dream of at first. At the start, he must learn the alphabet of dots and dashes. This means, for purposes of sending, that he must learn the little rhythmical pattern of finger movements that stands for each letter; and, for purposes of receiving, that he must learn the rhythmical

the record much below ten seconds; and any given individual's limit may be considerably worse than this, according to his build, muscular strength and quickness of nerve centers. The simple reaction gives another good example; every one has his limit, beyond which no amount of training will lower his reaction time; the neuromuscular system simply will not work any faster.

¹ A plateau of this sort is present in the learning curve for mastery of a puzzle, given on p. 316.

pattern of clicks from the sounder that stands for a letter. When he has learned the alphabet, he is able to send and receive slowly. In sending, he spells out the words, writing each letter as a separate act. In receiving, at this early stage, he must pick out each separate letter from the continuous series of clicks that he hears from the sounder. By degrees, the letters become so familiar that he goes through this spelling process easily; and, doing now so much better than at the outset, he supposes he has learned the trade, in its elements, and needs only to put on more speed.

But not at all! He has acquired but a small part of the necessary stock-in-trade of the telegrapher. He has his "letter habits", but knows nothing as yet of "word habits". These gradually come to him as he continues his practice. He comes to know words as units, motor units for sending purposes, auditory units for receiving. The rhythmical pattern of the whole word becomes a familiar unit. Short, much used words are first dealt with as units, then more and more words, till he has a large vocabulary of word habits. A word that has become a habit need not be spelled out in sending, nor laboriously dug out letter by letter in receiving; you simply think the word "train", and your finger taps it out as a connected unit; or, in receiving, you recognize the characteristic pattern of this whole series of clicks. When the telegrapher has reached this word habit stage, he finds the new method far superior, in both speed and sureness, to the letter habit method which he formerly assumed to be the whole art of telegraphy. He does not even stop with word habits, but acquires a similar control over familiar phrases.

HIGHER UNITS AND OVERLAPPING

The acquisition of skill in telegraphy consists mostly in learning these *higher units* of reactions. It is the same in

learning to typewrite. First you must learn your alphabet of letter-striking movements; by degrees you reduce these finger movements to firm habits, and are then in the letter-habit stage, in which you spell out each word as you write it. After a time, you write a familiar word without spelling it, by a coördinated series of finger movements; you write by word units, and later, in part, by phrase units; and these higher units give you speed and accuracy.

Along with this increase in the size of the reaction-units employed goes another factor of skill that is really very remarkable. This is the "overlapping" of different reactions, a species of doing two or more things at once, only that the two or more reactions are really parts of the same total activity. The simplest sort of overlap can be illustrated at an early stage in learning to typewrite. The absolute beginner at the typewriter, in writing "and", pauses after each letter to get his bearings before starting on the next; but after a small amount of practice he will locate the second letter on the keyboard while his finger is still in the act of striking the first letter. Thus the sensory part of the reaction to the second letter commences before the motor part of reacting to the first letter is finished; and this overlap does away with pauses between letters and makes the writing smoother and more rapid.

With further practice in typewriting, when word habits and phrase habits are acquired, overlap goes to much greater lengths. One expert kept her eyes on the copy about four words ahead of her fingers on the keyboard, and thus was reacting to about four words at the same time: one word was just being read from the copy, one word was being written, and the two words between were being organized and prepared for actual writing. The human typewriting mechanism, consisting of eye, optic nerve, parts of the brain and cord, motor nerves and muscles, works somewhat like one of

those elaborate machines which receive raw material steadily at one end perform a series of operations upon it, and keep turning out finished product at the other end.

All this is very remarkable, but the same sort of overlapping and working with large units can be duplicated in many linguistic performances that every one makes. In reading aloud, the eyes keep well ahead of the voice, and

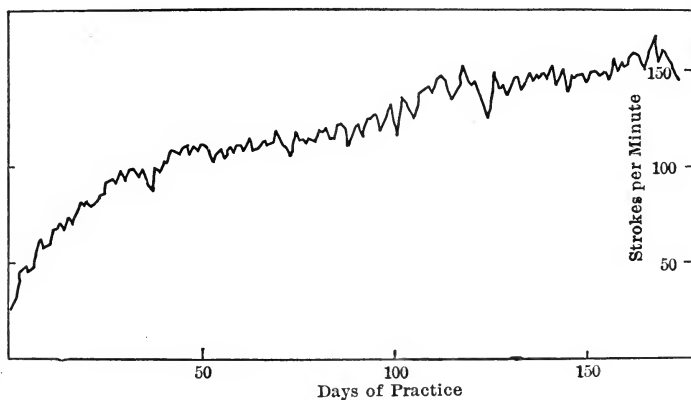

FIG. 52.—(From Book.) Practice curve of a young man learning to typewrite. Each point on the "curve" represents a daily record in number of strokes per minute. With improvement, the curve rises.

seeing, understanding and pronouncing are all applied simultaneously to different words of the passage read. In talking, the ideas keep developing and the spoken words tag along behind.

In telegraphy and typewriting, it is almost inevitable that the learner should start with the alphabet and proceed to gradually larger units. But in learning to talk, or to read, the process goes the other way. The child understands spoken words and phrases before breaking them up into their elementary vocal sounds; and he can better be taught to read by beginning with whole words, or even with whole

sentences, than by first learning the alphabet and laboriously spelling out the words. In short, the learning process often takes its start with the higher units, and reaches the smaller elements only for the purpose of more precise control.

MODERATE SKILL ACQUIRED IN THE ORDINARY DAY'S WORK

Merely repeating a performance many times does not give the high degree of skill that we see in the expert telegrapher or typist. Ordinarily, we practise much less assiduously, are much less zealous, and have no such perfect measure of the success of our work. For "practice to make perfect", it must be strongly motivated, and it must be sharply checked up by some index or measure of success or failure. If the success of a performance can be measured, and chalked up before the learner's eyes in the form of a practice curve, so that he can see his progress, this acts as a strong incentive to rapid improvement.

Ordinarily, we have no clear indication of exactly how well we are doing, and are satisfied if we get through our job easily and without too much criticism and ridicule from people around. Consequently we reach only a moderate degree of skill, nowhere near the physiological limit, and do not acquire the methods of the real expert.

This is very true of the manual worker. Typesetters of ten or more years' experience were once selected as subjects for an experiment on the effects of alcohol, because it was assumed that they must have already reached their maximum skill. In regard to alcohol, the result was that this drug caused a falling off in speed and accuracy of work—but that is another story. What we are interested in here is the fact that, as soon as these long-practised operators found themselves under observation, and their work measured, they all began to improve and in the course of a couple of weeks

reached quite a new level of performance. Their former level had been reasonably satisfactory under workaday conditions, and special incentive was needed to make them approach their limit.

A similar condition of affairs has been disclosed by "motion studies" in many kinds of manual work; the movements of the operative have been photographed or closely examined by the efficiency expert, and analyzed to determine whether there are any superfluous movements that could be eliminated, and whether a different method of work would be economical of time and effort. Usually, superfluous motion has been found and considerable economy seen to be possible. There is evidently no law of learning to the effect that continued repetition of a performance necessarily makes it perfect in speed, ease, or adaptation to the task in hand. What the manual worker attains as the result of prolonged experience is a passable performance, but not at all the maximum of skill.

The brain worker has little to brag of as against the manual worker. He, too, is only moderately efficient in doing his particular job. There are brilliant exceptions—bookkeepers who add columns of figures with great speed and precision, students who know just how to put in two hours of study on a lesson with the maximum of effect, writers who always say just what they wish to say and hit the nail on the head every time—but the great majority of us are only passable. We need strong incentive, we need a clear and visible measure of success or failure, we need, if such a thing were possible, a practice curve before us to indicate where we stand at the present moment with respect to our past and our possible future.

HABIT

A habit is contrasted with a reflex, in that the reflex is native, the habit acquired; but both are alike in being prompt and automatic reactions. The best antithesis to a habit is the response of a person to a novel situation, where neither nature nor previous experience gives him a ready response.

① The new response is exploratory and tentative, while habit is fixed and definite. The new response is variable, the habit ② regular. The new response is slow and uncertain, the habit ③ fairly quick and accurate. The new response is attended ④ by effort and strained attention, the habit is easy and often only half-conscious. The new response is apt to be unsatisfying ⑤ to the one who makes it, while habit is comfortable and a source of satisfaction.

To break a habit is most uncomfortable. Nature—at least that “second nature” which is habit—calls aloud for the customary performance. Strenuous effort is required to get out of the rut, and the slipping back into the rut which is almost sure to occur in moments of inadvertence is humiliating. Result—usually the habit sticks.

But if the habit simply must be broken? Breaking a habit is forming a counter-habit, and the more positive the counter-habit the better for us. This counter-habit must not be left to form itself, but must be practised diligently. Strong motivation is necessary, no half-hearted acquiescence in somebody else's injunction to get rid of the habit. We must adopt the counter-habit as *ours*, and work for a high standard of skill in it. For example, if we come to realize that we have a bad habit of grouchiness with our best friends, it is of little use merely to attempt to deaden this habit; we need to aim at being a positive addition to the company whenever we are present, and to practise the art of being good company, checking up our efforts to be sure we are hitting

the right vein, and persisting in our self-training till we become real artists. It takes some determination for a grouchy individual to make such a revolution in his conduct; his self-assertion resists violently, for the grouchiness is part and parcel of himself and he hates to be anything but himself. He must conceive a new and inspiring ideal of himself, and start climbing up the practice curve towards the new ideal.

EXERCISES

1. Outline the chapter.
2. Which of the acts performed in eating breakfast are instinctive, which are matters of habit, and which are partly the one and partly the other?
3. Compare your mental attitude in approaching an unfamiliar and a familiar task.
4. How does the performance of the expert in swimming or dancing, etc., differ from the performance of the beginner? Analyze out the points of superiority.
5. Show that the element of trial and error is present in (a) the child's learning to pronounce a word, and (b) learning "how to take" a person so as to get on well with him.
6. Why is it that our handwriting, though exercised so much, is apt to grow worse rather than better, while on the contrary our spelling is apt to improve?
7. How would you rate your efficiency in study? Is it near your physiological limit, on a plateau, or in a stage of rapid improvement?
8. A practice experiment. Take several pages of uniform printed matter, and mark it off into sections of 15 lines. Take your time for marking every word in one section that contains both *e* and *r*. The two letters need not be adjacent, but must both be present somewhere in the word. Having recorded your time for this first section, do the same thing with the next section, and so on for 12 sections. What were you able to observe, introspectively, of your method of work and changes with practice. From the objective observations, construct a practice curve.
9. Write brief explanations of the following terms:
 - practice
 - habit
 - higher unit
 - overlapping
 - plateau
 - physiological limit
 - insight
 - trial and error
 - negative adaptation
 - substitute stimulus
 - substitute response
 - conditioned reflex

REFERENCES

Thorndike's *Animal Intelligence, Experimental Studies*, 1911, reports his own pioneer work in this field. See also Chapter X in the same author's *Educational Psychology, Briefer Course*, 1914.

For other reviews of the work on animal learning, see Watson's *Behavior*, 1914, pp. 184-250; also Washburn's *Animal Mind*, 2nd edition, 1917, pp. 257-312.

For human learning and practice, see Thorndike's *Educational Psychology, Briefer Course*, 1914, Chapters XIV and XV; also Starch's *Educational Psychology*, 1919, Chapter XI.

For an experiment showing the acquisition of fears by a child, see Watson and Raynor, "Conditioned Emotional Reactions", in the *Journal of Experimental Psychology* 1920, Vol. 3, pp. 1-14.

James's chapter on "Habit", in his *Principles of Psychology*, 1890, Vol. I, is a classic which every one should read.

CHAPTER XIV

MEMORY

HOW WE MEMORIZE AND REMEMBER, AND IN WHAT
RESPECTS MEMORY CAN BE MANAGED AND IMPROVED

So much depends on a good memory in all walks of life, and especially in brain work of any sort, that perhaps it is no wonder that many students and business and professional men become worried about their memories and resort to "memory training courses" in the hope of improvement. The scientific approach to this very practical problem evidently lies through a careful study of the way in which memory works, and the general problem may be expressed in the question, how we learn and remember. This large problem breaks up, on analysis, into four subordinate questions: how we commit to memory, how we retain what has been committed to memory, how we get it back when we want it, and how we know that what we now get back is really what we formerly committed to memory. In the case of a person's name which we wish to remember, how do we "fix it in mind", how do we carry it around with us when we are not thinking of it, how do we call it up when needed, and what assures us that we have called up the right name? The four problems may be named those of

- (1) Memorizing, or learning,
- (2) Retention
- (3) Recall
- (4) Recognition

THE PROCESS OF MEMORIZING

As memorizing is one sort of learning, what we have found in the preceding chapter regarding the learning process should throw light on our present problem. We found animals to learn by doing, and man by doing and also by observation or observation combined with doing. Observation is itself a form of doing, a mental reaction as distinguished from a purely passive or receptive state; so that learning is always active. Observation we found to be of great assistance, both by way of hastening the learning process, and by way of making what is learned more available for future use. Our previous studies of learning thus lead us to inquire whether committing to memory may not consist partly in rehearsing what we wish to learn, and partly in observing it. Learning by rote, or by merely repeating a performance over and over again, is, indeed, a fact; and observant study is also a fact.

Let us see how learning is actually done, as indicated by laboratory experiments. The psychologist experiments a great deal with the *memorizing of nonsense material*, because the process can be better observed here, from the beginning, than when sensible material is learned. Suppose a list of twenty one-place numbers is to be studied till it can be recited straight through. The learner may go at it simply by "doing", which means here by reading the list again and again, in the hope that it will finally stick. This pure rote learning will perhaps do the job, but it is slow and inefficient. Usually the learner goes to work in quite a different way. He observes various facts about the list. He notices what numbers occur at the beginning and end, and perhaps in other definite positions. He may group the digits into two-place or three-place numbers, and notice the characteristics of these. Any familiar combinations that

may occur, such as 1492, he is likely to spy and remember. Lacking these, he can at least find similar and contrasting number-groups.

For example, the list

5 7 4 0 6 2 7 3 5 1 4 0 9 2 8 6 3 8 0 1,

which at first sight seemed rather bare of anything characteristic, was analyzed in a way partly indicated by the commas and semicolons,

5, 74, 0; 62, 73; 5140; 9, 286; 380, 1,

and memorized easily. These observed facts transformed the list from a shapeless mass into something having definite characteristics, and the observed characteristics stuck in mind and held the rest together.

Lists of nonsense syllables, such as

wok pam zut bip seg ron taz vis lub mer koj yad

are apt to be learned largely by observation of similarities and contrasts, by reading meanings into the syllables, and by grouping into pairs and reading rhythmically. Grouping reduces the twelve syllables to six two-syllabled nonsense words, some of which may suggest meaningful words or at least have a swing that makes them easy to remember. Perhaps the first syllable of every pair is accented, and a pause introduced after each pair; such devices assist memorizing.

The rhythmical and other *groups* that are found or made by the learner in memorizing nonsense lists are, in effect, "higher units", and have much the same value as the higher units of telegraphy or typewriting. One who learns many lists in the course of a laboratory experiment develops a regu-

lar system of grouping. First he reads the list through, in groups of two, three or four items, noticing each group as a whole; later, he notices the items in each group and how they are related to each other. He also notices the interrelations of different groups, and the position of each group in the total series. All this is quite different from a mere droning along through the items of the list; it is much more active, and much more observant.

Very interesting are the various ways in which the learner attacks a list of nonsense syllables, numbers, or disconnected words. He goes to work something like the cat trying to escape from a strange cage. He proceeds by a sort of trial and error observation; he keeps looking for something about the list that will help to fix it. He sees something that promises well for a moment, then gives it up because he sees something better. He notices positions, i.e., connects items with their position in the list. He finds syllables that stand out as peculiar in some way, being "odd", "fuzzy", smooth, agreeable, disagreeable, or resembling some word, abbreviation or nickname. He notes resemblances and contrasts between different syllables. He also finds groups that resemble each other, or that resemble words.

Besides what he actually finds in the list, he imports *meanings*, more or less far-fetched, into the list. He may make a rhythmical line of verse out of it; he may make a story out of it. In short, he both explores the list as it stands and manipulates it into some shape that promises to be rememberable.

His line of attack differs according to the particular test that is later to be made of his memory. Suppose he is shown a number of pictures, with the understanding that later those now shown are to be mixed with others, and that he must then pick out those now shown—then he simply examines each picture for something characteristic. But sup-

pose each picture is given a name, and he must later tell the name of each—then he seeks for something in the picture that can be made to suggest its name. Or suppose, once more, that the pictures are spread out before him in a row, and he is told that they will later be mixed and he be required to rearrange them in the same order in which they are now shown—then he seeks for relationships between the several pictures. His process of memorizing, always observant, exploratory and manipulatory, differs in detail according to the memory task that he expects later to perform.

For another example, suppose an experiment is conducted by the method of “paired associates”. The subject is handed a list of pairs of words, such as

soprano.....	emblem
grassy.....	concise
nothing.....	ginger
faraway.....	kettle
shadow.....	next
mercy.....	scrub
hilltop.....	internal
recite.....	shoestring
narrative....	thunder
seldom.....	harbor
jury.....	eagle
windy.....	occupy
squirm.....	hobby
balloon.....	multiply
necktie.....	unlikely
supple.....	westbound
obey.....	inch
broken.....	relish
spellbound...	ferment
desert	expect

He must learn to respond with the second word of each pair when the first word of the pair is given. What he does, in learning this lesson, is to take each pair of words as a unit, and try to find something in the pair that shall make it a firm unit. It may be simply the peculiar sound or look of a pair that he notes, or it may be some connection

of meaning. Perhaps the pair suggests an image or a little story. After a few readings, he has the pairs so well in hand that he can score almost one hundred per cent., if tested immediately.

But now suppose the experimenter springs a surprise, by asking the subject, as far as possible, to recite the pairs in order, or to tell, after completing one pair, what was the first word of the next pair. The subject can do very little at this, and protests that the test is not fair, since he "paid no attention to the order of the pairs, but concentrated wholly on each pair separately". Had he expected to recite the whole list of pairs in order, he would have noticed the relationship of successive pairs, and perhaps woven them into a sort of continued story.

In memorizing *connected passages* of prose or poetry, the "facts observed" are the general sense and drift of the passage, the meanings of the parts and their places in the general scheme, the grammatical structure of the sentences and phrases, and the author's choice of particular words. Memorizing here is the same general sort of observant procedure as with nonsense material, greatly assisted by the familiar sequences of words and by the connected meaning of the passage, so that a connected passage can be learned in a fraction of the time needed to memorize an equally long list of unrelated words. No one in his senses would undertake to memorize an intelligible passage by the pure rote method, for this would be throwing away the best possible aid in memorizing; but you will find students who fail to take full advantage of the sense, because, reading along passively, they are not on the alert for general trends and outlines. For fixing in mind the sense of a passage, the essential thing is to see the sense. If the student gets the point with absolute clearness, he has pretty well committed it to memory.

Short-circuiting. The peculiarities of words or syllables in a list or passage that is being memorized, the relationships observed among the parts, and the meanings suggested or imported into the material, though very useful in the early stages of memorizing, tend to drop out of mind as the material becomes familiar. A pair of syllables, "lub—mer", may have first been associated by turning them into "love mother", but later this meaning fades out, and the two syllables seem simply to belong together in their own right. A pair of words, like "seldom—harbor", that were first linked together by the intermediary thought of a boat that seldom came into the harbor, become directly bound together as mere words. A short-circuiting occurs, indirect attachments giving way to direct. Even the outline and general purpose of a connected passage may fade out of mind, when the passage becomes well learned, so that it may be almost impossible for a schoolboy, who has learned his little speech by heart, to deliver it with any consciousness of its real meaning. A familiar act flattens out and tends to become automatic and mechanical.

ECONOMY IN MEMORIZING

Memorizing is a form of mental work that is susceptible of management, and several principles of scientific management have been worked out that may greatly assist in the learning of a long and difficult lesson. The problem has been approached from the angle of economy or efficiency. Suppose a certain amount of time is allowed for the study of a lesson, how can this time be best utilized?

The first principle of economy has already been sufficiently emphasized: observant study, directed towards the finding of relationships and significant facts, is much more efficient than mere dull repetition.

The value of recitation in memorizing. "Recitation" here means reciting to oneself. After the learner has read his lesson once or twice, he may, instead of continuing simply to read it, attempt to recite it, prompting himself without much delay when he is stuck, and verifying his recitation by reference to the paper. The question is whether this active reciting method of study is or is not economical of time in memorizing, and whether or not it fixes the lesson durably in memory. The matter has been thoroughly tested, and the answer is unequivocally in favor of recitation. The only outstanding question is as to how soon to start attempting to recite, and probably no single answer can be given to this question, so much depends on the kind of material studied, and on peculiarities of the individual learner. Where the sense rather than the exact wording of a lesson has to be learned, it is probably best to recite, in outline, after the first reading, and to utilize the next reading for filling in the outline.

The results of one series of experiments on this matter are summarized in the adjoining table.

THE VALUE OF RECITATION IN MEMORIZING (from Gates)

Material studied	16 nonsense syllables		5 short biographies, totalling about 170 words	
	Per cent. remembered immedi- ately	after 4 hours	Per cent. remembered immedi- ately	after 4 hours
All time devoted to reading	35	15	35	16
1/5 of time devoted to recitation	50	26	37	19
2/5 of time devoted to recitation	54	28	41	25
3/5 of time devoted to recitation	57	37	42	26
4/5 of time devoted to recitation	74	48	42	26

The time devoted to study was in all cases 9 minutes, and this time was divided between reading and recitation in different proportions as stated in the first column at the left. Reading down the next column,

we find that when nonsense syllables were studied and the test was conducted immediately after the close of the study period, 35 per cent. were remembered when all the study time had been devoted to reading, 50 per cent. when the last $\frac{1}{5}$ of the study time had been devoted to recitation, 54 per cent. when the last $\frac{2}{5}$ of the time had been devoted to recitation; and so on. The next column shows the per cents. remembered four hours after the study period. Each subject in these experiments had before him a sheet of paper containing the lesson to be studied, and he simply read it till the experimenter gave a signal to recite, after which the subject recited the lesson to himself as well as he could, prompting himself from the paper as often as necessary, and proceeded thus till the end of the study period. The subjects in these particular experiments were eighth grade children; adult subjects gave the same general results.

Three facts stand out from the table: (1) Reading down the columns, we see that recitation was always an advantage. (2) The advantage was more marked in the test conducted four hours after study than in the test immediately following the study. To be sure, there is always a falling off from the immediate to the later test; there is bound to be some forgetting when the lesson has been studied for so short a time as here; but the forgetting proceeds more slowly after recitation than after all reading. Recitation fixes the matter more durably. (3) The advantage of recitation is less marked in the meaningful material than in case of nonsense syllables, though it is marked in both cases. The reason is that meaningful material can better be read observantly, time after time, than is possible with nonsense material. Continued reading of nonsense material degenerates into a mere droning, while in repeatedly reading meaningful material the learner who is keenly interested in mastering the passage is sure to keep his mind ahead of his eyes to some extent, so that his reading becomes half recitation, after all.

Whence comes the advantage of recitation? It has a two-fold advantage: it is more stimulating, and it is more satisfying. When you know you are going to attempt recitation at once, you are stimulated to observe positions, peculiarities, relationships, and meanings, and thus your study

goes on at a higher level than when the test of your knowledge is still far away, with many readings still to come. You are also stimulated to manipulate the material, by way of grouping and rhythm.

On the side of satisfaction, recitation shows you what parts of the lesson you have mastered and gives you the glow of increasing success. It shows you exactly where you are failing and so stimulates to extra attention to those parts of the lesson. It taps the instincts of exploration, manipulation, and mastery much more effectively than continued re-reading of the same lesson can do. The latter becomes very uninteresting, monotonous and fatiguing.

Perhaps, after all, the greatest advantage of reciting is that it makes you do, in learning, the very act that you have later to perform in the test; for what you have finally to do is to recite the lesson without the book. When reading, you are doing something different; and if it were altogether different, it probably would not help you at all towards success in the test. But since intelligent reading consists partly in anticipating and outlining as you go, it is a sort of half recitation, it is halfway doing what you are trying to learn to do. Memorizing consists in performing an act, now, with assistance, that you later wish to perform without assistance; and recitation first stimulates you to fashion the act conformably to the object in view, and then exercises you in performing that act.

Spaced and unspaced repetition. Another question on the economical management of memorizing: Is it better to keep steadily going through the lesson till you have it, or to go through it at intervals? If you were allowed a certain time, and no more, in which to prepare for examination on a certain memory lesson, how could the study time be best distributed? This question also has received a very definite answer.

Spaced repetitions are more effective than unspaced. In an experiment of Piéron, a practised subject went through a list of twenty numbers with an interval of only thirty seconds between readings, and needed eleven readings to master the list. But a similar list, with five-minute intervals, was mastered in six readings; and the number of readings went down to five with an interval of ten minutes, and remained the same for longer intervals up to two days. With this particular sort of lesson, then, ten minutes was a long enough interval, and two days not too long, to give the greatest economy of time spent in actual study.

In a somewhat different experiment in another laboratory, lists of nonsense syllables were studied either two, four, or eight times in immediate succession, and this was repeated each day till a total of twenty-four readings had been given to each list; then, one day after the last reading of each list, the subjects were tested as to their memory of it. The result appears in the adjoining table.

EFFECT OF SPACED STUDY ON ECONOMY OF MEMORIZING
(From Jost)

Distribution of the 24 readings	Total score of Mr. B.	Total score of Mr. M.
8 readings a day for 3 days	18	7
6 " " " " 4 "	39	31
2 " " " " 12 "	53	55

The widest distribution gave the best score. Undoubtedly, then, if you had to memorize a poem or speech, you would get better value for time spent if you read it once or twice at a time, with intervals of perhaps a day, than if you attempted to learn it at one continuous sitting. What exact spacing would give the very greatest economy would depend on the length and character of the lesson.

Spaced study also fixes the matter more durably. Every student knows that continuous "cramming" just before an

examination, while it may accomplish its immediate purpose, accomplishes little for permanent knowledge.

When we say that spaced repetitions give best results in memorizing, that does not mean that study generally should be in short periods with intervals of rest; it says nothing one way or the other on that question. The probability is, since most students take a certain time to get well "warmed up" to study, that fairly long periods of consecutive study would yield larger returns than the same amount of time divided into many short periods. What we have been saying here is simply that repetition of the *same material* fixes it better in memory, when an interval (not necessarily an empty interval) elapses between the repetitions.

Whole versus part learning. In memorizing a long lesson, is it more economical to divide it into parts, and study each part by itself till mastered, or to keep the lesson entire and always go through the whole thing? Most of us would probably guess that study part by part would be better, but experimental results have usually been in favor of study of the whole.

If you had to memorize 240 lines of a poem, you would certainly be inclined to learn a part at a time; but notice the following experiment. A young man took two passages of this length, both from the same poem, and studied one by the whole method, the other by the part method, in sittings of about thirty-five minutes each day. His results appear in the table.

LEARNING PASSAGES OF 240 LINES, BY WHOLE AND PART METHODS (Pyle and Snyder)

Method of study	Number of days required	Total number of minutes required
30 lines memorized per day, then whole reviewed till it could be recited	12	431
3 readings of whole per day till it could be recited ...	10	348

Here there was an economy of eighty-three minutes, or nearly twenty per cent., by using the whole method as against the part method. Similar experiments have regularly given the same general result.

However, the matter is not quite so simple, as, under certain conditions, the results tend the other way. Let us consider a very different type of learning test. A "pencil maze", consisting of passages or grooves to be traced out with a pencil, while the whole thing was concealed from the subject by a screen, was so arranged that it could be divided into four parts and each part learned separately. Four squads of learners were used. Squads A and B learned the maze as a whole, squads C and D part by part. Squads A and C learned by spaced trials, two trials per day. Squad B learned the whole thing at one sitting; while squad D, which came off best of all, learned one part a day for four days, and on the fifth day learned to put the parts together. The results appear in the adjoining table, which shows the average time required to master the maze by each of the four methods.

PART AND WHOLE LEARNING, SPACED AND UNSPACED,
IN THE PENCIL MAZE (From Pechstein)

	Spaced trials	Unspaced trials
Whole learning	A 641 seconds	B 1250 seconds
Part learning	C 1220 "	D 538 "

When the trials were spaced, the whole method was much the better; but when the trials were bunched, the part method was much the better; and, on the whole, the unspaced part learning was the best of all. Thus the result stands in apparent contradiction with two accepted laws: that of the advantage of spaced learning, and that of the advantage of whole learning.

This contradiction warns us not to accept the "laws"

too blindly, but rather to analyze out the factors of advantage in each method, and govern ourselves accordingly. Among the factors involved are the following four:

(1) The factor of interest, confidence and visible accomplishment—the emotional factor, we might call it. This is on the side of part learning, especially with beginners, who soon feel out of their depth when wading into a long lesson, and lose hope of ever learning it in this way. This factor is also largely on the side of unspaced as against spaced learning, when the part studied is of moderate length and when there are recitations to keep up the interest; for when the learner sees he is getting ahead, he would rather keep right on than wait for another day to finish. To have a task that you can hope to accomplish at once, and to attack it with the intention of mastering it at once, is very stimulating.

(2) The factor of recency, of “striking while the iron is hot”. When an act has just been successfully performed it can easily be repeated, and when a fact has just been observed it can readily be put to use. This factor is clearly on the side of unspaced learning; and it is also on the side of part learning, since by the time you have gone through the whole long lesson and got back to where you are now, the recency value of what you have just now accomplished will have evaporated.

(3) The factor of meaning, outlining and broad relationships. This is on the side of whole learning, for it is when you are going through the whole that you catch its general drift, and see the connections of the several parts and their places in the whole. This factor is so important as to outweigh the preceding two in many cases, especially with experienced learners dealing with meaningful material. Even if you should prefer the part method, you would be wise to begin by a careful survey of the whole.

(4) The factor of permanency. This is something "physiological", and it is on the side of spaced learning. The muscles profit more by exercise with intervals of rest than by a large amount of continuous exercise, and no athlete would think for a moment of training for a contest of strength by "cramming" for it. Apparently the neurones obey the same law as the muscles, and for that reason spaced learning gives more durable results than unspaced.

UNINTENTIONAL LEARNING

What we have been examining is intentional memorizing, with the "will to learn" strongly in the game. The assertion has sometimes been made that the will to learn is necessary if any learning is to be accomplished. We must look into this matter, for it has an important bearing on the whole question of the process of learning.

There is a famous incident that occurred in a Swiss psychological laboratory, when a foreign student was supposed to be memorizing a list of nonsense syllables. After the list had been passed before him many times without his giving the expected signal that he was ready to recite, the experimenter remarked that he seemed to be having trouble in memorizing the syllables. "Oh! I didn't understand that I was to learn them", he said, and it was found that, in fact, he had made almost no progress towards learning the list. He had been observing the separate syllables, with no effort to connect them into a series.

Another incident: subjects were put repeatedly through a "color naming test", which consisted of five colors repeated in irregular order, the object being to name the one hundred bits of color as rapidly as possible. After the subjects had been through this test over two hundred times, you would think they could recite it from memory; but not

at all! They had very little memory of the order of the bits of color. Their efforts had been wholly concentrated upon naming the bits as seen, and not in connecting them into a series that could be remembered.

The experiment described a few pages back on "paired associates" is another case in point. The subjects memorized the pairs, but made no effort to connect the pairs in order, and consequently were not able later to remember the order of the pairs.

Many somewhat similar experiments have been performed, with the object of measuring the reliability of the testimony of eye-witnesses; and it has been found that testimony is very unreliable except for facts that were specifically noted at the time. Enact a little scene before a class of students who do not suspect that their memory of the affair is later to be tested, and you will find that their memory for many facts that were before their eyes is hazy, absent, or positively false.

These facts all emphasize the importance of the will to learn. But let us consider another line of facts. An event occurs before our eyes, and we do notice certain facts about it, not with any intention of remembering them later, but simply because they arouse our interest; later, we recall such facts with great clearness and certainty. Or, we hear a tune time after time, and gradually come to be able to sing it ourselves, without ever having attempted to memorize it. Practically all that the child learns in the first few years of his life, he learns without any "will to learn".

What is the difference between the case where the will to learn is necessary, and the case where it is unnecessary? The difference is that in the one case we observe facts for the purpose of committing them to memory, and in the other case we observe the facts without any such intention. In both cases we remember what we have definitely observed,

and fail to remember what we have not observed. Sometimes, to be sure, it is not so much observation as doing that is operative. We may make a certain reaction with the object of learning it so as to make it later, or we may make the reaction for some other reason; but in either case we learn it.

What is essential, then, is not the will to learn, but the doing and observing. The will to learn is sometimes important, as a directive tendency, to steer doing and observing into channels relevant to the particular memory task that we need to perform. But committing to memory seems not to be any special form of activity; rather, it consists of reactions that also occur without any view to future remembering. Not only do we learn *by* doing and observing, but doing and observing *are* learning.

RETENTION

We come now to the second of our four main problems, and ask how we retain, or carry around inside of us, what we have learned. The answer is, not by any process or activity. Retention is a resting state, in which a learned reaction remains until the stimulus arrives that can arouse it again. We carry around with us, not the reaction, but the machinery for making the reaction.

Consider, for example, the retention of motor skill. A boy who has learned to turn a handspring does not have to keep doing it all the time in order to retain it. He may keep himself in better form by reviewing the performance occasionally, but he retains the skill even while eating and sleeping. The same can be said of the retention of the multiplication table, or of a poem, or of knowledge of any kind. The machinery that is retained consists very largely in brain connections. Connections formed in the process of

learning remain behind in a resting condition till again aroused to activity by some appropriate stimulus.

But the machinery developed in the process of learning is subject to the wasting effects of time. It is subject to the law of "atrophy through disuse". Just as a muscle, brought by exercise into the pink of condition, and then left long inactive, grows weak and small, so it is with the brain connections formed in learning. With prolongation of the condition of rest, the machinery is less and less able to function, till finally all retention of a once-learned reaction may be lost.

But *is* anything once learned ever completely forgotten and lost? Some say no, being strongly impressed by cases of recovery of memories that were thought to be altogether gone. Childhood experiences that were supposed to be completely forgotten, and that could not at first be recalled at all, have sometimes been recovered after a long and devious search. Sometimes a hypnotized person remembers facts that he could not get at in the waking state. Persons in a fever have been known to speak a language heard in childhood, but so long disused as to be completely inaccessible in the normal state. Such facts have been generalized into the extravagant statement that nothing once known is ever forgotten. For it is an extravagant statement. It would mean that all the lessons you had ever learned could still be recited, if only the right stimulus could be found to arouse them; it would mean that all the lectures you ever heard (and attended to) are still retained, that all the stories you ever read are still retained, that all the faces you ever noticed are still retained, that all the scenes and happenings that ever got your attention could still be revived if only the right means were taken to revive them. There is no evidence for any such extreme view,

The modern, scientific study of this matter began with

recognizing the fact that there are *degrees of retention*, ranging all the way from one hundred per cent. to zero, and with the invention of methods of measuring retention. Suppose you have memorized a list of twenty numbers some time ago, and kept a record of the time you then took to learn it; since when you have not thought of it again. On at-

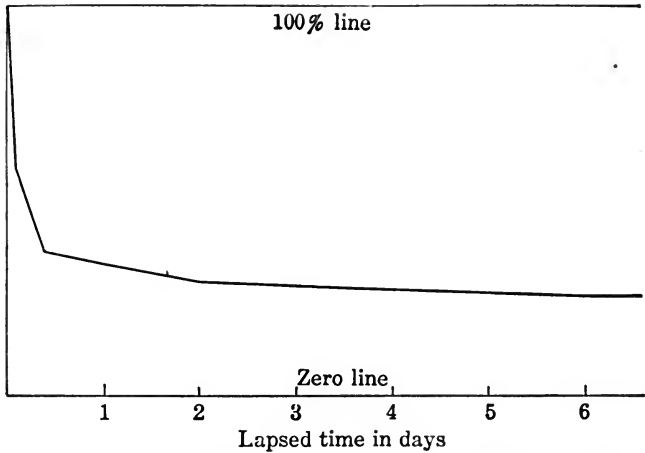

FIG. 53.—(From Ebbinghaus.) The curve of forgetting. The curve sinks at first rapidly, and then slowly, from the 100 per cent. line towards the zero line, 100 per cent. here meaning perfect retention, and 0 no retention.

tempting now to recite it, you make no headway and are inclined to think you have entirely forgotten it. But, finding the list again, you *relearn* it, and probably find that your time for relearning is less than the original learning time—unless the lapse of time has run into months. Now consider—if no time at all were needed for relearning, because the list could be recited easily without, your retention would be one hundred per cent. If, on the contrary, it took you just as long now to relearn as it did originally to learn, the retention would be zero. If it takes you now two-thirds as long to relearn as it originally took to learn, then one-

third of the work originally done on the list does not have to be done over, and *this saving is the measure of retention.*

By the use of this method, the curve of retention, or curve of forgetting, as it is also called, has been determined. It is a curve that first goes down steeply, and then more and more gradually, till it approximates to zero; which means that the loss of what has been learned proceeds rapidly at first and then more and more slowly.

The curve of forgetting can be determined by other methods besides the saving method—by the recall method or by the recognition method; and data obtained by these methods are given in the adjoining tables. It will be seen that the different methods agree in showing a curve that falls off more rapidly at first than later. More is lost in the first hour than in the second hour, and more in the first week than in the second week. Few of the experiments have been continued long enough to bring the curve actually to the zero line, but it has come very close to that line in tests conducted after an interval of two to four months.

PER CENT. OF WORDS RECOGNIZED AT DIFFERENT INTERVALS AFTER BEING SEEN (From Strong)

Interval between exposure and test	Per cent. recognized with certainty and correctness
15 secs.	84
5 min.	73
15 min.	62
30 min.	58
1 hour	56
2 hours	50
4 hours	47
8 hours	40
12 hours	38
1 day	29
2 days	24
4 days	19
7 days	10

The subject read a list of 20 disconnected words once through, giving careful attention to each word. Immediately at the close of the reading he performed an example in mental arithmetic, to prevent his reviewing the list of words mentally. After an interval, he was shown these

twenty words mixed with twenty others, and had to pick out those he surely recognized as having been shown before. Many lists were used, for testing after the different intervals. Five adult subjects took part in the experiment, and in all 15 lists were used with each interval; the per cents. given in the table are the averages for the 15 lists.

THE PER CENT. OF ERROR IN RECALLING DETAILS OF A
PICTURE AFTER DIFFERENT INTERVALS OF TIME
(From Dallenbach)

Time of test	Per cent. of error in spontaneous recall	Per cent. of error in answering questions regard- ing the picture
Immediately after exposure	10	14
After 5 days	14	18
“ 15 “	18	20
“ 45 “	22	22

The picture was placed in the subject's hands, and he examined it for one minute, at the end of which time he wrote down as complete a description of the picture as possible, and then answered a set of sixty questions covering all the features of the picture. After five days he was retested in the same way, and again after fifteen days, etc. In one respect this is not a typical memory experiment, since the test after five days would revive the subject's memory of the picture and slacken the progress of forgetting. The experiment corresponds more closely to the conditions of ordinary life, when we do recall a scene at intervals; or it corresponds to the conditions surrounding the eye-witness of a crime, who must testify regarding it, time after time, before police, lawyers and juries. However, the subjects in this experiment realized at the time that they were to be examined later, and studied the picture more carefully than the eye-witness of a crime would study the event occurring before his eyes; so that the per cent. of error was smaller here than can be expected in the courtroom.

It must be understood that this classical curve of forgetting only holds good, strictly, for material that has *barely* been learned. Reactions that have been drilled in thoroughly and repeatedly fall off very slowly at first, and the further course of the curve of forgetting has not been accurately followed in their case. A typist who had spent perhaps two hundred hours in drill, and then dropped type-writing for a year, recovered the lost ground in less than an hour of fresh practice, so that the retention, as measured by the saving method, was over ninety-nine per cent.

Somewhat different from the matter of the curve of forgetting is the question of the *rate of forgetting*, as depend-

ent on various conditions. The rate of forgetting depends, first, on the thoroughness of the learning, as we have just seen. It depends on the kind of material learned, being very much slower for meaningful than for nonsense material, though both have been learned equally well. Barely learned nonsense material is almost entirely gone by the end of four months, but stanzas of poetry, just barely learned, have shown a perceptible retention after twenty years.

Very fortunately, the principles of economy of memorizing hold good also for retention. Forgetting is slower when relationships and connections have been found in the material than when the learning has been by rote. Forgetting is slower after active recitation than when the more passive, receptive method of study has been employed. Forgetting is slower after spaced than after unspaced study, and slower after whole learning than after part learning.

An old saying has it that quick learning means quick forgetting, and that quick learners are quick forgetters. Experiment does not wholly bear this out. A lesson that is learned quickly because it is clearly understood is better retained than one which is imperfectly understood and therefore slowly learned; and a learner who learns quickly because he is on the alert for significant facts and connections retains better than a learner who is slow from lack of such alertness. The wider awake the learner, the quicker will be his learning and the slower his subsequent forgetting; so that one is often tempted to admonish a certain type of studious but easy-going person, "for goodness' sake not to dawdle over his lessons", with any idea that the more time he spends with them the longer he will remember them. More gas! High pressure gives the biggest results, provided only it is directed into high-level observation, and does not simply generate fear and worry and a rattle-brained frenzy of rote learning.

RECALL

Having committed something to memory, how do we get it back when we want it? To judge from such simple cases as the animal's performance of a previously learned reaction, all that is necessary is a *stimulus* previously linked with the response. How, for example, shall we get the cat to turn the door-button, this being an act that the cat has previously learned? Why, we put the cat into the same cage, i.e., we supply the stimulus that has previously given the reaction, and trust to it to give the same reaction again. The learning process has attached this reaction to this stimulus. Now can we say the same regarding material committed to memory by the human subject? Is recall a species of learned reaction that needs only the linked stimulus to arouse it?

If you have learned and still retain a list of numbers or syllables, you can recite it on thinking of it, on hearing words that identify it in your mind, or on being given the first few items in the list as a start. The act of reciting the list became linked, during the learning, with the thought of the list, with words signifying this particular list, and with the first items of the list; therefore, these stimuli can now arouse the reaction of reciting the list. As you advance into the list, reciting it, the parts already recited act as stimuli to keep you going forward. In the same way, if you have memorized Hamlet's soliloquy, this title serves as the stimulus to make you recall the beginning of the speech and that in turn calls up the next part and so on; or, if you have analyzed the speech into an outline, the title calls up the outline and the outline acts as the stimulus to call up the several parts that were attached to the outline in the process of memorization. When one idea calls up another, the first acts as a stimulus and the second is a re-

sponse previously attached to this stimulus. (In general, then, recall is a learned response to a stimulus)

There is an exceptional case, where recall seems to occur without any stimulus. This form of recall goes by the name of *perseveration*, and a good instance of it is the "running of a tune in the head", shortly after it has been heard. Another instance is the vivid flashing of scenes of the day before the "mind's eye" as one lies in bed before going to sleep. It appears as if the sights or sounds came up of themselves and without any stimulus. Possibly there is some vague stimulus which cannot itself be detected. Only a slight stimulus would be needed, because these recent and vivid experiences are so easily aroused.

Difficulties in recall. Sometimes recall fails to materialize when we wish it and have good reason for expecting it. We know this person's name, as is proved by the fact that we later recall it, but at the moment we cannot bring it up. We know the answer to this examination question, but in the heat of the examination we give the wrong answer, though afterwards the right answer comes to mind. This seldom happens with thoroughly learned facts, but frequently with facts that are moderately well known. Some sort of inhibition or interference blocks recall.

One type of interference is emotional. Fear may paralyze recall. Anxious self-consciousness, or stage fright, has prevented the recall of many a well-learned speech, and interfered with the skilful performance of many a well-trained act.

Distraction is an interference, since it keeps the stimulus from exerting its full effect. Sometimes the stimulus that is present has been linked with two or more responses, and these get in each other's way; as you will sometimes hear a speaker hesitate and become confused from having two ways

of expressing the same thought occur to him at almost the same instant.

Helps in recall. There are no sure rules for avoiding these intricate interferences; and, in general, recall being a much less manageable process than memorizing, we do not have anything like the same mass of practical information regarding it. One or two suggestions have some value, however.

(1) Give the stimulus a good chance. Look squarely at the person whose name you wish to recall, avoiding doubt as to your ability to recall it; for doubt is itself a distraction. Put yourself back into the time when you formerly used this person's name. In extemporaneous speaking, go ahead confidently, avoid worry and self-consciousness, and, full of your subject, trust to your ideas to recall the words as needed. Once carried away with his subject, a speaker may surprise himself by his own fluency.

(2) Drop the matter for a while, and come back to it afresh. Sometimes, when you cannot at once recall a name, it does no good to keep doggedly hunting, while half an hour later you get it without the least trouble. The explanation of this curious phenomenon is found in interference and the dying out of interference. At your first attempt to recall the name, you simply got on the wrong track, and thus gave this wrong track the "recency" advantage over the right track; but this temporary advantage fades out rapidly with rest and leaves the advantage with the track most used in the past.

The rule to drop a matter when baffled and confused, and take it up again when fresh, can be used in more complex cases than hunting for a name. When, in trying to solve any sort of problem, you find yourself in a rut, about the only escape is to back off, rest up, and make an entirely fresh start.

RECOGNITION

The fourth question propounded at the beginning of the chapter, as to how we can know that the fact now recalled is what we formerly committed to memory and now wish to recall, is part of the larger question of how we recognize. What we recognize includes not only facts recalled, but also facts not recalled but presented a second time to the senses. Recognition of objects seen, heard, touched, etc., is the most rudimentary form of memory. The baby shows signs of recognizing persons and things before he shows signs of recall. A little later, he recognizes and understands words before he begins to speak (recall) them; and everybody's vocabulary of recognized words remains much greater than his speaking vocabulary. We recognize faces that we could not recall, and names that we could not recall. In short, recognition is easier than recall.

Consequently any theory of recognition that makes it depend on recall can scarcely be correct. One such theory held that an object is recognized by recalling its original setting in past experience; an odor would be recognized by virtue of recalling the circumstances under which it was formerly experienced. Now sometimes it does happen that an odor which seems familiar, but cannot be identified, calls up a past experience and thus is fully recognized; but such "indirect recognition" is not the usual thing, for direct recognition commonly takes place before recall of the past experience has time to occur. You see a person, and know him at once, though it may require some moments before you can recall where and when you have seen him before.

Recognition may be more or less complete. At its minimum, it is simply a "feeling of familiarity" with the object; at its maximum it is locating the object precisely in your autobiography. You see a man, and say, "He looks

familiar, I must have seen him somewhere", and then it dawns on you, "Oh! yes, now I know exactly who he is; he is the man who . . ." Between these extremes lie various degrees of recognition. This man seems to be some one seen recently, or a long, long time ago, or at the seashore, or as a salesman in a store; or as some one you looked up to, or felt hostility towards, or were amused at; and often these impressions turn out to be correct, when you succeed in fully recognizing the person. These impressions resemble the first signs of recognition in the baby's behavior; you say that the baby remembers people because he smiles at one who has pleased him before, and shrinks from one who has displeased him.

Recognition described in terms of stimulus and response. Recognition is a form of learned response, depending on previous reaction to the object recognized. To recognize an object is to respond to it as we responded before—except for the feeling of familiarity, which could not occur the first time we saw the object. But notice this: though the object is the same identical object it was before, it may have changed somewhat. At least, its setting is different; this is a different time and perhaps a different place, and the circumstances are bound to be more or less different. In spite of this difference in the situation, we make the same response as before.

Now, the response we made to the object in its original setting was a response to the whole situation, object *plus* setting; our response to the object was colored by its setting. When we now recognize the object, we make the same response to the object in a different setting; the response originally called out by the object *plus* its setting is now aroused by the object alone. Consequently we have an uneasy feeling of responding to a situation that is not present.

This uneasy feeling is the feeling of familiarity in its more haunting and "intriguing" form.

We see some one who seems familiar and who arouses a hostile attitude in us that is not accounted for in the least by his present actions. We have this uneasy feeling of responding to a situation that is not present, and cannot rest till we have identified the person and justified our hostile attitude.

Or, we see some one who makes us feel as if we had had dealings with him before in a store or postoffice where he must have served us; we find ourselves taking the attitude towards him that is appropriate towards such a functionary, though there is nothing in his present setting to arouse such an attitude. Or, we see some one in the city streets who seems to put us back into the atmosphere of a vacation at the seashore, and by searching our memory we finally locate him as an individual we saw at such and such a resort. At other times, the feeling of familiarity is rather colorless, because the original situation in which the person was encountered was colorless; but we still have the feeling of responding to something that is not present. We make, or start to make, the same response to the person that we originally made to him *plus* his setting, and this response to something that is not there gives the feeling of familiarity.

When we see the same person time after time in the same setting, as when we go into the same store every morning and buy a paper from the same man, we cease to have any strong feeling of familiarity at sight of him, the reason being that we are always responding to him in the same setting, and consequently have no feeling of responding to something that is not there. But if we see this same individual in a totally different place, he may give us a queer feeling of familiarity. When we see the same person time after time

in various settings, we end by separating him from his surroundings and responding to him alone, and therefore the familiarity feeling disappears.

Complete recognition, or "placing" the object, involves something more than these feelings and rudimentary reactions. It involves the recall of a context or scheme of events, and a fitting of the object into the scheme.

MEMORY TRAINING

The important question whether memory can be improved by any form of training breaks up, in the light of our previous analysis, into the four questions, whether memorizing can be improved, whether the power of retention can be improved, whether recall can be improved, and whether recognition can be improved. As to recognition, it is difficult to imagine how to train it; the process is so elusive and so direct. It has been found, however, that practice in recognizing a certain class of objects improves one's standards of judgment as to whether a feeling of familiarity is reliable or not; it enables one to distinguish between feelings that have given correct recognitions and the vaguer feelings that often lead one astray.

As to recall, certain hints were given above as to the efficient management of this process, and probably practice in recalling a certain sort of facts, checked up by results, would lead to improvement.

As to retention, since this is not a performance but a resting state, how could we possibly go about to effect an improvement? One individual's brain is, to be sure, more retentive than another's; but that seems a native trait, not to be altered by training.

On the other hand, the process of committing to memory, being a straightforward and controllable activity, is exceed-

ingly susceptible to training, and it is there, for the most part, that memory training should be concentrated in order to yield results. It does yield marked results. In the laboratory, the beginner in learning lists of nonsense syllables makes poor work of it. He is emotionally wrought up and uncertain of himself, goes to work in a random way (like any beginner), perhaps tries to learn by pure rote or else attempts to use devices that are ill-adapted to the material, and has a slow and tedious job of it. With practice in learning this sort of material, he learns to observe suitable groupings and relationships, becomes sure of himself and free from the distraction of emotional disturbance, and may even come to enjoy the work. Certainly he improves greatly in speed of memorizing nonsense syllables. If, instead, he practises on Spenser's "Faery Queen", he improves in that, and may cut down his time for memorizing a twelve-line stanza from fifteen minutes to five. This improvement is due to the subject's finding out ways of tackling this particular sort of material. He gets used to Spenser's style and range of ideas. And so it is with any kind of material; practice in memorizing it brings great improvement in memorizing that particular material.

Whether practice with one sort of material brings skill that can be "transferred", or carried over to a second kind of material, is quite another question. Usually the amount of *transfer* is small compared with the improvement gained in handling the first material, or compared with the improvement that will result from specific training with the second kind. What skill is transferred consists partly of the habit of looking for groupings and relationships, and partly in the confidence in one's own ability as a memorizer. It is really worth while taking part in a memory experiment, just to know what you can accomplish after a little training. Most persons who complain of poor memory would be con-

vinced by such an experiment that their memory was fundamentally sound. But these laboratory exercises do not pretend to develop any general "power of memory", and the much advertised systems of memory training are no more justified in such a claim. What is developed, in both cases, is skill in memorizing certain kinds of material so as to pass certain forms of memory test.

One who suffers from poor memory for any special material, as names, errands, or engagements, probably is not going to work right in committing the facts to memory; and if he gives special attention to this particular matter, keeping tab on himself to see whether he improves, he is likely to find better ways of fixing the facts and to make great improvement. It was said of a certain college president of the older day that he never failed to call a student or alumnus by name, after he had once met the man. How did he do it? He had the custom of calling each man in the freshman class into his office for a private interview, during which, besides fatherly advice, he asked the man personal questions and studied him intently. He was interested in the man, he formed a clear impression of his personality, and to that personality he carefully attached the name. Undoubtedly this able scholar was possessed of an unusually retentive memory; but his memory for names depended largely on his method of committing them to memory.

Contrast this with the casual procedure of most of us on being introduced to a person. Perhaps we scarcely notice the name, and make no effort to attach the name to the personality. To have a good memory for names, one needs to give attention and practice to this specific matter. It is the same with memory for errands; it can be specifically trained. Perhaps the best general hint here is to connect the errand beforehand in your mind with the

place where you should think, during the day, to do the errand.

Often some little *mnemonic system* will help in remembering disconnected facts, but such devices have only a limited field of application and do not in the least improve the general power of memory. Some speakers, in planning out a speech, locate each successive "point" in a corner of the hall, or in a room of their own house; and when they have finished one point, look into the next corner, or think of the next room, and find the following point there. It would seem that a well-ordered discourse should supply its own logical cues so that such artificial aids would be unnecessary.

In training the memory for the significant facts that constitute the individual's knowledge of his business in life, the best rule is to systematize and interrelate the facts into a coherent whole. Thus a bigger and stronger stimulus is provided for the recall of any item. This, along with the principles of "economy" in memorizing, is the best suggestion that psychology has to make towards memory improvement.

EXERCISES

1. In outlining the chapter, regroup the material so as to separate the practical applications from the description of memory processes. This gives you two main heads: A. Memory processes, and B. The training and management of memory. Each of these main heads should be divided into four sub-heads: Memorizing, retention, etc., and the information contained in the chapter grouped under these sub-heads.

2. Disorders of memory can be classified under the four heads of disorders of learning, of retention, of recall and of recognition. Where would you place each of the following?

- (a) Aphasia, where, through brain injury, the subject's vocabulary is very much reduced.
- (b) The condition of the very old person, who cannot remember what has happened during the day, though he still remembers experiences of his youth.
- (c) The "feeling of having been there before", in which you have a weird impression that what is happening now has happened in just the same way before, as if events were simply repeating themselves.
- (d) The loss of memory which sometimes occurs after a physical or emotional shock, or after a fever, and which passes away after a time.

3. How fully can you recall what happened on some interesting occasion when you were a child of 5-8 years? Dwell on the experience, and see whether you get back more than at first seemed possible. Try the same with an experience of five years ago.

4. If a student came to you for advice, complaining of poor memory, and said that though he put hours and hours on a lesson and read it over many times, still he failed on it, what questions would you ask regarding his method of study, and what suggestions would you offer?

5. An experiment on memorizing lists of numbers. Prepare several lists of 20 digits, and shuffle them; draw out one and take your time for learning it to the point of perfect recitation. Write an introspective account of the process. Repeat with a second list.

6. An experiment in memorizing word-pairs. Prepare 20 pairs of words as follows: take 20 cards or slips of paper, and write a different word on each. Then turn them over, shuffle, and write another word on the back of each. Thus, though you may know what words you have written, you do not know how they are paired; and now your job is to learn the pairs. Note starting time, take the first card and look at both

sides, and study the pair of words on this card for about 5 seconds, passing then to the second card, and so on through the pack. Shuffle the pack, take the top card and give yourself about 5 seconds to recall the word on the reverse, then turning the card over and reading it. Proceed in this way through the pack, shuffle again, and repeat. Continue thus till you score 100 per cent. Note total time required, and report on process of memorizing.

7. Memorizing a series of related words. Prepare a list of 40 words, as follows: first write the numbers 1 to 40 in a column; then write any word for No. 1; for No. 2, write some word closely related to No. 1; for No. 3 some word closely related to No. 2; and so on. Your list, for example, might begin like this: house, roof, chimney, soot, fire, coal, mine, miner, strike, arbitration, etc. Having finished writing your list, cover it and see how much of it you can recite without further study, and how long it takes you to complete the memorizing. Explain the results obtained.

8. Plot the curve of forgetting from the following data, which give the per cent. of retention of stanzas of a poem at different intervals after the end of memorizing.

after 1 day.....	79%
after 2 days.....	67%
after 6 days.....	42%
after 14 days.....	30%
after 30 days.....	24%

REFERENCES

Ebbinghaus, *On Memory*, 1885, translated by Ruger and Bussenius, 1913. This is the pioneer experimental study of memory, and is still worth reading, and is not specially hard reading.

James's chapter on Memory, in Vol. I of his *Principles of Psychology*, 1890, is still one of the best references, and contains some important remarks on the improvement of memory.

Of the numerous special studies on memory, mention may be made of that by Arthur I. Gates, *Recitation as a Factor in Memorizing*, 1917, which, on pp. 65-104, gives a valuable account of the various devices used by one who is memorizing.

For the psychology of testimony, see G. M. Whipple's article on "The Obtaining of Information: Psychology of Observation and Report", in the *Psychological Bulletin* for 1918, Vol. 15, pp. 217-248, especially pp. 233-248. See also a popularly written account of the matter by Münsterberg, in *On the Witness Stand*, 1908, pp. 15-69.

CHAPTER XV

ASSOCIATION AND MENTAL IMAGERY

SOMETHING ABOUT THINKING AS RELATED TO MEMORY

Memory plays a part, not only in "memory work", and not only in remembering particular past experiences, but in all sorts of thinking. Recall furnishes the raw material for thought. A large share of any one's daily work, whether it be manual or mental, depends on the recall of previously learned reactions. Most of the time, though we are not exactly trying to remember facts committed to memory, we are recalling what we have previously learned, and utilizing the recalled material for our present purposes. For example, in conversation we recall words to express our meaning, and we recall the meanings of the words we hear. In adding a column of figures, we recall the sums of the numbers. In cooking a meal, we recall the ingredients of the dish we wish to prepare, and the location of the various materials and utensils required for our purpose. In planning a trip, we recall places and routes. Any sort of problem is solved by means of recalled facts put together in a new way. A writer in constructing a story puts together facts that he has previously noted, and any work of the imagination consists of materials recalled from past experience and now built into a new composition.

WHAT CAN BE RECALLED

If recall is so important in thinking and acting, it is worth while to make a survey of the materials that recall

furnishes. In general, using the term "recall" rather broadly, we say that any previously learned reaction may be recalled. Writing *movements* may be said to be recalled when we write, and speech movements when we speak. "Higher units", like the word habits and phrase habits of the telegrapher and typist, are in a broad sense recalled whenever they are used. The typist does not by any means recall the experience of learning a higher unit, but he calls into action again the response that he has learned to make. In the same way, the word habits and phrase habits of vocal speech are called into action, i.e., recalled, whenever we speak.

Besides these motor reactions, *tendencies* to reaction can be recalled. The attitude of hostility that may have become habitual in us towards a certain person, or towards a certain task, is called into activity at the mention of that person or task. The acquired interest in architecture that we may have formed by reading or travel is revived by the sight of an ambitious group of buildings. A slumbering purpose may be recalled into activity by some relevant stimulus.

Observed *facts* can be recalled, and this is the typically human form of recall. In animals, we see the recall of tendencies and of learned movements, but no clear evidence of the recall of observed facts. To be recalled with certainty, a fact must have been definitely noted when it was before us. If we have definitely noted the color of a person's eyes, we are in a position to testify that his eyes are brown, for example; otherwise, we may say that we think probably his eyes are brown; because we have certainly noticed that he is dark, and the dark eyes fit best into this total impression.

We say that a fact is recalled when we think of it without its being present to the senses. While the original ob-

servation of the fact was a response to a sensory stimulus, the recall of it is a response to some other stimulus, some "substitute stimulus". When John is before me, I observe that his eyes are brown in response to a visual stimulus; but I later recall this fact in response simply to the name "John", or in response to the question as to what is the color of John's eyes. I see what a square is by seeing squares and handling them, and later I get this idea simply in response to the word "square" in conversation or reading.

MEMORY IMAGES

Now, can *sensations* be recalled, can they be aroused except by their natural sensory stimuli? Can you recall the color blue, or the sound of a bugle, or the odor of camphor, or the feel of a lump of ice held in the hand? Almost every one will reply "Yes" to some at least of these questions. One may have a vivid picture of a scene before the "mind's eye", and another a realistic sound in the "mind's ear", and they may report that the recalled experience seems essentially the same as the original sensation. Therefore, sensory reactions are no exception to the rule of recall by a substitute stimulus.

A sensation or complex of sensations recalled by a substitute stimulus is called a "mental image" or a "memory image".

Individuals seem to differ in the vividness or realism of their memory images—the likeness of the image to an actual sensation—more than in any other respect. Galton, in taking a sort of census of mental imagery, asked many persons to call up the appearance of their breakfast table as they had sat down to it that morning, and to observe how lifelike the image was, how complete, how adequate in respect to color, how steady and lasting, and to compare

the image in these respects with the sensory experience aroused by the actual presence of the scene. Some individuals reported that the image was "in all respects the same as an original sensation", while others denied that they got anything at all in the way of recalled sensation, though they could perfectly well recall definite facts that they had observed regarding the breakfast table. The majority of people gave testimony intermediate between these extremes.

Individuals differ so much in this respect that they scarcely credit each other's testimony. Some who had practically zero imagery held that the "picture before the mind's eye" spoken of by the poets was a myth or mere figure of speech; while those who were accustomed to vivid images could not understand what the others could possibly mean by "remembering facts about the breakfast table without having any image of it", and were strongly tempted to accuse them of poor introspection, if not worse. It is true that in attempting to study images, we have to depend altogether on introspection, since no one can objectively observe another person's memory image, and therefore we are exposed to all the unreliability of the unchecked introspective method. But at the same time, when you cross-question an individual whose testimony regarding his imagery is very different from yours, you find him so consistent in his testimony and so sure he is right, that you are forced to conclude to a very real difference between him and yourself. You are forced to conclude that the power of recalling sensations varies from something like one hundred per cent. down to practically zero.

Individuals may also differ in the *kind* of sensation that they can vividly recall. Some who are poor at recalling visual sensations do have vivid auditory images, and others who have little of either visual or auditory imagery call up

kinesthetic sensations without difficulty. When this was first discovered, a very pretty theory of "imagery types" was built upon it. Any individual, so it was held, belonged to one or another type: either he was a "visualist", thinking of everything as it appears to the eyes, or he was an "audile", thinking of everything according to its sound, or he was a "motor type", dealing wholly in kinesthetic



According to the
type theory

According to the
facts

FIG. 54.—Individual differences in mental imagery. According to the type theory, every individual has a place in one or another of the distinct groups, visual, auditory, tactile, kinesthetic, or olfactory. According to the facts, the majority of individuals cluster in the middle space, and form a single large group, though some few are extremely visual, or auditory, etc., in their imagery.

imagery, or he might, in rare cases, belong to the olfactory or gustatory or tactile type.

But the progress of investigation showed, first, that a "mixed type" must also be admitted, to provide for individuals who easily called up images of two or more different senses; and, later on, that the mixed type was the most common. In fact, it is now known to be very unusual for an individual to be confined to images of a single sense. Nearly every one gets visual images more easily and frequently than those of any other sense, but nearly every one has, from time to time, auditory, kinesthetic, tactile and olfactory images. So that the "mixed type" is the only real type, the extreme visualist or audile, etc., being exceptional and not typical.

LIMITATIONS OF IMAGERY

Recalled sensations are commonly inferior to their originals, both in the enjoyment they afford and in the use that can be made of them. They are likely to be inferior in several respects.

(1) An image has usually less color, or tone—less body, realism and full sensory quality—than a sensation aroused by its appropriate peripheral stimulus. While you may be able to call up a fairly good image of your absent friend's face, the actual presence of your friend would be more satisfactory, just as a sensory experience. You may be able to run over a piece of music "in your head", and if your auditory imagery is strong you may even run over an orchestral piece, and get the tone quality of the various instruments; but, after all, such a mental concert is an imperfect substitute for a real orchestra. You enjoy a real whiff of the sea more than the best olfactory image you can summon. There is something lacking in these recalled sensations, and the trouble seems to be that they are not sensations enough; they lack sensory body.

(2) Images are apt to be sketchy and lacking in detail, and also narrow and lacking in background.

(3) Images are apt to be unsteady and fleeting, as compared with actual sensations. Where the peripheral stimulus, continuing, keeps the sensation going, the substitute stimulus that recalls a sensation is not so effective in this respect, any more than in giving body and detail. In all these respects, an image is less enjoyable and satisfying than an actual sensation.

(4) On the more practical side, images are inferior to the actual presence of an object, in that we cannot utilize the image as a source of new information. We *cannot observe*

facts in the image of a thing that we have not observed in the actual presence of the thing.

At one of the universities, there is a beautiful library building, with a row of fine pillars across the front, and the students pass this building every day and enjoy looking at it. It has long been a favorite experiment in the psychology classes at that university to have the students call up an image of the library, and to have them state how clear their image is, how complete and how vivid. Then they are asked to count the pillars from their image, and to tell what kind of capitals the pillars have, and whether the shafts are plain or fluted. But at this point the students begin to object. "We have never counted those pillars, and cannot be expected to know the number now." In fact, few of them give the correct number, and those who have reported clear and vivid images are little better off in this respect than those whose images are dim and vague.

The image, then, does not give you facts that you did not observe in the presence of the object. The substitute stimulus, which now recalls the image, only recalls responses which you made when the real object was the stimulus. If you looked at the object simply to get its general appearance, the general appearance is all you can recall. If you noted the color of the object, you can probably recall the color. If you noted such details as the number of pillars, you can recall these details. But the substitute stimulus that now arouses the image is by no means the equivalent of the original peripheral stimulus in making possible a variety of new reactions. Its only linkage is with reactions actually made by you in response to the real object. The substitute stimulus, such as the name of a building, became linked with responses actually made by you, not with responses that you simply might have made, when the object was present. This important fact is closely related to the

unreliability of testimony that was mentioned before under the head of "unintentional memory".¹ Facts recalled are facts previously observed.

It is true, of course, that recalled facts can be compared and new facts be observed by the comparison. We may recall how John looks, and how James looks, and note the fact, not previously observed, that they look alike. A great deal can be inferred in this way by a person who is sitting in his room far from the objects thought about. But this noting of the relationships of different objects is a very different matter from observing what is there, in a single object or scene. What is there can only be observed when you are there.

THE QUESTION OF NON-SENSORY RECALL

Many observed facts are not strictly facts of sensation, though observed by means of the senses. Let us suppose, for an example, that your attention is caught by the bright green new leaves at the tips of the branches of an evergreen tree in summer, and that you notice also the darker green of the older leaves further back along the branches, and, exploring deeper, find leaves that are dead and brown, while still further in they have all fallen off, leaving bare branches reaching back to the trunk; so that you finally "see" how the tree is constructed, as a hollow cone of foliage supported by an interior framework of branches. All this has meant a lot of different reactions on your part, and the final "seeing" of how the tree is constructed would scarcely be called a sensation, since it has required mental work beyond that of simply seeing the tree. It is a response additional to the strictly sensory response of seeing the tree.

Now the question is whether this additional response can be recalled, without recalling at the same time the primary

¹ See pp. 346-348.

response of seeing the tree. Can we recall the fact observed about the tree without at the same time seeing the tree "in the mind's eye"? Must we necessarily have an image of the tree when we recall the way the tree is constructed?

Since getting the general sensory appearance of the tree, and observing the way it is constructed, are two different responses, it seems quite conceivable that either fact should be recalled without the other; and no one doubts that the sensory appearance of the tree can be recalled without the other observed fact coming up along with it. But many authorities have held that the non-sensory fact could not be recalled alone; in other words, they have held that every recalled fact comes as a sensory image, or with a sensory image. Persons with ready visual imagery are of course likely to get a visual image with any fact they may recall. But persons whose visual imagery is hard to arouse say that they recall facts without any visual image. I who write these words, being such a person, testify that while I have been writing and thinking about that tree I have not seen it before my mind's eye.

It is true, however, that I have had images during this time—auditory images of words expressing the facts mentioned. Another individual might have had kinesthetic images instead of either visual or auditory. But can there be a recall of fact without *any* sensory image?

On this question, which has been called the question of "imageless thought", though it might better be called that of "imageless recall", controversy has raged and is not yet at rest, so that a generally accepted conclusion cannot be stated. But the best indications are to the effect, first, that vague and fleeting images, especially of the kinesthetic sort, are often present without being detected except by very fine introspection, some image being pretty sure to come up every few seconds when we are engaged in silent thought or

recall; but, second, that images are not present every second of the time, and that at the instant when a non-sensory fact is recalled it is apt to be alone.

HALLUCINATIONS

Since a vivid mental image may be "in all respects the same as an actual sensation", according to the testimony of some people, the question arises how, then, an image is distinguished from a sensation. Well, the image does not usually fit into the objective situation present to the senses. But if it does fit, or if the objective situation is lost track of, then, as a matter of fact, the image may be taken for a sensation.

You see some beautiful roses in the florist's window, and you *smell* them; the odor fits into the objective situation very well, till you notice that the shop door is shut and the window glass impervious to odors, from which you conclude that the odor must have been your image.

You are lost in thought of an absent person, till, forgetting where you are, you seem to see him entering the door; he "fits" well enough for an instant, but then the present situation forces itself upon you and the image takes its proper place.

You are half asleep, almost lost to the world, and some scene comes before you so vividly as to seem real till its oddity wakens you to the reality of your bedroom. Or you are fully asleep, and then the images that come are dreams and seem entirely real, since contact with the objective situation has been broken.

Images taken for real things are common in some forms of mental disorder. Here the subject's hold on objective fact is weakened by his absorption in his own desires and fears, and he hears reviling voices and smells suspicious

odors or sees visions that are in line with his desires and fears.

Such false sensations are called "hallucinations". An hallucination is an image taken for a sensation, a recalled fact taken for a present objective fact. It is a sensory response, aroused by a substitute stimulus, without the subject's noticing that it is thus aroused instead of by its regular peripheral stimulus.

Synesthesia. Quite a large number of people are so constituted as to hear sounds as if colored, a deep tone perhaps seeming dark blue, the sound of a trumpet a vivid red, etc. Each vowel and even each consonant may have its own special color, which combine to give a complex color scheme for a word. Numbers also may be colored. This colored hearing is the commonest form of "synesthesia", which consists in responding to a stimulus acting on one sense, by sensations belonging to a different sense. Whether the persons so constituted as to respond in this way are constituted thus by nature or by experience is uncertain, though the best guess is that the extra sensations are images that have become firmly attached to their substitute stimuli during early childhood.

FREE ASSOCIATION

Mental processes that depend on recall are called "associative processes", since they make use of associations or linkages previously formed. When some definite interest or purpose steers the associative processes, we speak of "controlled association", contrasting this with the "free association" that occurs in an idle mood, when one thought simply calls up another with no object in view and no more than fleeting desires to give direction to the sequence of thoughts.

Revery affords the best example of free association. I

see my neighbor's dog out of my window, and am reminded of one time when I took charge of that dog while my neighbor was away, and then of my neighbor's coming back and taking the dog from the cellar where I had shut him up; next of my neighbor's advice with respect to an automobile collision in which I was concerned; next of the stranger with whom I had collided, and of the stranger's business address on the card which he gave me; next comes a query as to this stranger's line of business and whether he was well-to-do; and from there my thoughts switch naturally to the high cost of living.

This is rather a drab, middle-aged type of reverie, and youth might show more life and color; but the linkages between one thought and the next are typical of any reverie. The linkages belong in the category of "facts previously observed". I had previously observed the ownership of this dog by my neighbor, and this observation linked the dog and the neighbor and enabled the dog to recall the neighbor to my mind. Most of the linkages in this reverie are quite concrete, but some are rather abstract, such as the connection between being well-to-do (or not) and the high cost of living; but, concrete or abstract, they are connections previously observed by the subject. Sometimes the linkage keeps the thoughts within the sphere of the same original experience, and sometimes switches them from one past experience to another, or even away from any specific past experience to general considerations; yet always the linkage has this character, that the item that now acts as stimulus has been formerly combined in observation with the other item that now follows as the response. One fact recalls another when the two have been previously observed as belonging together.

But suppose, as is commonly the case, that the fact now present in my mind has been linked, in different past experi-

ences, with several different facts. Then two questions demand our attention: whether all these facts are recalled; and, if not, what gives the advantage to the fact actually recalled over the others that are not recalled.

The answer to the first question is plain. The fact first present in mind does not call up all the associated facts, but usually only one of them, or at least only one at a time. My neighbor, in the example given, though previously associated with a dozen other facts, now calls up but two of these facts, and those two not simultaneously but one after the other. We see a law here that is very similar to a law stated under the head of attention. There, we said that of all the objects before us that might be noticed only one was noticed at a time; and here we say that of all the objects that might be recalled to mind by association only one is recalled at a time. Both statements can be combined into the one general "law of reaction" which was mentioned before, that of all the responses linked to a given stimulus (or complex of stimuli) only one is actually aroused at the same instant, though several may be aroused in succession, provided the stimulus continues.

In reverie, the stimulus usually does not continue. The first fact thought of gives way to the fact that it recalls, and that to one that it recalls in turn, and so on, without much dwelling on any fact. But if we do dwell on any fact—as upon the thought of a certain person—then this stimulus, continuing to act, calls up in succession quite a number of associated facts.

If, then, only one of the several facts associated with the stimulus is recalled at once, our second question presents itself, as to what are the factors of advantage that cause one rather than another of the possible responses to occur. The fact first in mind might have called up any one of several facts, having been linked with each of them in past ex-

perience; and we want to know why it recalls one of these facts rather than the rest.

The factors of advantage in recall are the factors that determine the strength of linkage between two facts; and they are:

the *frequency* with which the linkage has occurred;
 the *recency* with which it has occurred; and
 the *intensity* with which it has occurred.

If I have frequently observed the connection of two facts, the linkage between them is strong; if I have recently observed their connection, the linkage between them is strong till the "recency value" dies away; and if my observation of the connection of the two facts was a vivid experience, or intense reaction, then, also, the linkage between them is strong. If these three factors of advantage work together in favor of the same response, then that response is sure to occur; but if the three factors pull different ways, we should have to figure out the balance of advantage before we could predict which of the possible responses would actually be made. Naturally enough, even the skilful psychologist is often unable to strike the balance between the three factors. He does know, however, and all of us know in a practical way, that strong recency value offsets a lot of frequency; so that a mere vague allusion to a very recent topic of conversation can be depended on to recall the right facts to the hearer's mind, even though they lie outside of his habitual line of interest. "James", by virtue of frequency, means your brother or friend; but after the lecturer has been talking about the psychologist James, repetition of this name infallibly recalls the psychologist to mind.

Besides frequency, recency and intensity, there is, indeed, another factor to be taken into account; and that is the

present state of the subject's mind. If he is unhappy, unpleasant associations have the advantage; if happy, pleasant. If he is absorbed in a given matter, facts related to that matter have the advantage. Frequency, recency and intensity summarize the *history* of associations, and measure their strength as dependent on their history; but the present state of mind is an additional directive factor, and when it has much to do with recall, we speak of directed or controlled association.

Before we pass to the topic of controlled association, however, there is another form of free association, quite different from revery, to be examined. There is an experiment, called the *free association test*, in which the subject is given a series of words as stimuli, and is asked to respond to each word by speaking some other word, the first that is recalled by the stimulus. No special kind of word need be given in response, but simply the *first word recalled*. Though this is called free association, it is controlled to the extent that the response must be a word, and the result is very different from revery. Instead of the recall of concrete facts from past experience, there is recall of words. If you give the subject the stimulus word, "table", his response is "chair" or "dinner", etc., and often he does not think of any particular table, but simply of the word. Words are so often linked one with another that it is no wonder that one recalls another automatically. What particular word shall be recalled depends on the frequency, recency and intensity of past linkage.

Though this form of test seems so simple as almost to be silly, it is of use in several ways. When a large number of stimulus words are used, and the responses classified, some persons are found to favor linkages that have a personal significance—"egocentric responses", these are called—while other persons run to connections that are imper-

sonal and objective. Thus the test throws some light on the individual's *habits* of attention. The test has also a "detective" use, based upon the great efficacy of the factor of *recency*; you may be able by it to tell whether an individual has recently had a certain matter in mind. If he happens to be an individual who has recently committed some crime, properly selected stimulus words will lead him to recall the scene of the crime, and thus to make responses that betray him, unless he checks them and so arouses suspicion by his hesitation. Another use of the test is for unearthing a person's emotional "complexes", which of course possess a high *intensity* value. If the subject shows hesitation and embarrassment in responding to words referring to money, the indication is that he is emotionally disturbed over the state of his finances. One person who consulted a doctor for nervousness made peculiar responses to stimulus words relating to the family, and was discovered to be much disturbed over his family's opposition to his projected marriage. The free association test is useful rather as giving the experienced psychologist hints to be followed up than as furnishing sure proof of the contents of the subject's mind.

CONTROLLED ASSOCIATION

There is a controlled association test conducted like this one in free association, except that the subject is required to respond to each stimulus word by a word standing in a specified relation to it. To one series of words he must respond by saying their opposites; to another, by mentioning a part of each object named; to another series, consisting of names of countries, he must respond by naming as quickly as possible the capital of each country named; and there are many tests of this sort, each dealing with some class of relationships which, being often observed, are easily handled

by a person of normal intelligence. The intelligent subject makes few errors in such a test, and responds in very quick time. Indeed, the remarkable fact is that he takes less time to respond in an easy controlled association test than in the free association test; which shows that the "control" acts not simply to limit the response, but also to *facilitate* it.

The "control" here is often called by the name of "mental set". It is a good example of a "reaction tendency". On being told you are to give opposites, you somehow set or adjust your mental machinery for making this type of response. The mental set thus thrown into action facilitates responses of the required type, while inhibiting other responses that would readily occur in the absence of any directive tendency. If the word "good" came as a stimulus word in a free association test, it might easily arouse the responses, "good day", "good night", "good boy", "good better", and many besides, since all of these combinations have been frequently used in the past; and the balance of frequency, recency and intensity might favor any one of these responses. But when the subject is set for opposites, the balance of these factors has little force as against the mental set. The mental set for opposites favors the revival of such combinations as "new—old", "good—bad", and such others of this class as have been noted and used in the subject's past experience.

Mental set is a selective factor, a factor of advantage. It does not supersede the previously formed associations, or work independently of them, but selects from among them the one which fits the present task. Does it get in its work after recall has done its part, or before? Does it wait till recall has brought up a number of responses, and then pick out the one that fills the bill? No, it often works much too quickly for that, giving the right response instantly; and introspection is often perfectly clear that none but the right

response is recalled at all. The selective influence of the mental set is exerted *before recall*; it facilitates the right recall and inhibits recall of any but the right response.

In controlled association, as in free association, only one of the facts previously linked with the stimulus is recalled at a time; but while in free association the factors of frequency, recency and intensity of past linkage determine which of the many possible facts shall be recalled, in controlled association the additional factor of mental set is present and has a controlling influence in determining which fact shall be recalled. Thus, in an opposites test, the stimulus word "good" promptly calls up the pair "good—bad", because the mental set for opposites gives this response a great advantage over "good night" and other responses which may have a very strong linkage with the stimulus word.

The mental set is itself a response to a stimulus. It is an inner response thrown into activity by some stimulus, such as the stimulus of being asked to give the opposites of a series of words that are presently to be shown or spoken. This inner response of getting ready for the task can be introspectively observed by a person who is new to this type of test. It may take the form of mentally running over examples of opposites—or whatever kind of responses are to be called for—or it may take the form of calling up some image or diagram or gesture that symbolizes the task. A visual image of the nose on the face may serve as a symbol of the part-whole relationship, a small circle inside a larger one may symbolize the relation of an object to a class of objects, and gesturing first to the right and then to the left may symbolize the relationship of opposites. But as the subject grows accustomed to a given task, these conscious symbols fade away, and nothing remains except a general "feeling of readiness" or of "knowing what you are

about". The mental set remains in force, however, and is no less efficient for becoming almost unconscious.

EXAMPLES OF CONTROLLED ASSOCIATION

Dwelling so long on the test for controlled association may have created the impression that this is a rather artificial and unusual type of mental performance; but in reality controlled association is a very representative mental process, and enters very largely into all forms of mental work. This is true in arithmetical work, for example. A pair of numbers, such as 8 and 3, has been linked in past experience with several responses; it means 83, it means 11, it means 5, and it means 24. But if you are adding, it means 11, and no other response occurs; if you are multiplying, it means 24, and only that response occurs. The mental set for multiplying facilitates the responses of the multiplication table and inhibits those of the addition table, while the mental set for adding does the reverse. Rapid adding or multiplying would be impossible without an efficient mental set. Thus in arithmetic, as in the tests, the mental set is an inner response to the *task*.

In reading, there is a mental set which is an inner response to the *context*, and which determines which of the several well-known meanings of a word shall actually be called to mind when the word is read. Presented alone, a word may call up any of its meanings, according to frequency, etc.; but in context it usually brings to mind just the one meaning that fits the context. The same is true of conversation.

The objective *situation* arouses a mental set that controls both thought and action. The situation of being in church, for example, determines the meanings that are got from the words heard, and controls the motor behavior to

fit the occasion. The subject, observing the situation, adjusts himself to it, perhaps without any conscious effort, and his adjustment facilitates appropriate mental and motor reactions, while inhibiting others.

A *problem* arouses a mental set directed towards solution of the problem. A difficult problem, however, differs from a context or familiar task or situation in this important respect, that the appropriate response has not been previously linked with the present stimulus, so that, in spite of ever so good a mental set, the right response cannot immediately be recalled. One must *search* for the right response. Still, the mental set is useful here, in directing the search, and keeping it from degenerating into an aimless running hither and thither. Problem solution is so different a process from smooth-running controlled association that it deserves separate treatment, which will be given it a few chapters further on, under the caption of reasoning.

EXERCISES

1. Outline the chapter.

2. The rating of images belonging under different senses. Try to call up the images prescribed below, and rate each image according to the following scale:

3. . . . *The image is practically the same as a sensation, as bright, full, incisive, and, in short, possessed of genuine sensory quality.*

2. . . . *The image has a moderate degree of sensory quality.*

1. . . . *The image has only faint traces of sensory quality.*

0. . . . *No sensory image is called up, though there was a recall of the fact mentioned.*

Call up visual images of: a friend's face, a sun flower, a white house among trees, your own signature written in ink.

Call up auditory images of: the sound of your friend's voice, a familiar song, an automobile horn, the mewing of a cat.

Call up olfactory images of: the odor of coffee, of new-mown hay, of tar, of cheese.

Call up gustatory images of: sugar, salt, bitter, acid.

Call up cutaneous images of: the feel of velvet, a lump of ice, a pencil held against the tip of your nose, a pin pricking your finger.

Call up kinesthetic imagery of: lifting a heavy weight, reaching up to a high shelf, opening your mouth wide, kicking a ball.

Call up organic imagery of: feeling hungry, feeling thirsty, feeling nausea, feeling buoyant.

In case of which sense do you get the most lifelike imagery, and in case of which sense the least. By finding the average rating given to the images of each sense, you can arrange the senses in order, from the one in which your imagery rates highest to the one in which it rates lowest. It may be best to try more cases before reaching a final decision on this matter.

3. Verbal imagery. When you think of a word, do you have a visual, auditory, or kinesthetic image of it—or how does it come?

4. In reading, notice how much imagery of objects, persons, scenes, sounds, etc., occurs spontaneously.

5. Analysis of a reverie. Take any object as your starting point, and let your mind wander from that wherever it will for a minute.

Then review and record the series of thoughts, and try to discover the linkages between them.

6. Free association experiment. Respond to each one of a list of disconnected words by saying the first word suggested by it. Use the following list: city, war, bird, potato, day, ocean, insect, mountain, tree, roof.

7. Controlled association. (a) Use the same list of stimulus words as above, but respond to each by a word meaning the *opposite* or at least something contrasting. (b) Repeat, naming a *part* of the object designated by each of these same words. (c) Repeat again, naming an *instance* or variety of each of the objects named. Did you find wrong responses coming up, or did the mental set exclude them altogether?

8. Write on a sheet of paper ten pairs of one-place numbers, each pair in a little column with a line drawn below, as in addition or multiplication examples. See how long it takes you to *add*, and again how long it takes to *multiply* all ten. Which task took the longer, and why? Did you notice any interference, such as thinking of a sum when you were "set" for products?

9. Free association test for students of psychology. Respond to each of the following stimulus words by the first word suggested by it of a psychological character:

conditioned	objective	gregarious
delayed	correlation	fear
negative	end-brush	mastery
rat	pyramidal	submission
stimulus	semicircular	feeling-tone
substitute	kinesthetic	primary
axon	advantage	tension
synapse	field	blend
autonomic	quotient	rod
retention	limit	fovea
nonsense	apraxia	saturated
higher	thalamus	red-green
paired	organic	complementary
economy	tendency	after
exploration	preparatory	basilar
recency	native	fluctuation
curve	endocrine	dot
perseveration	expressive	Binet
synesthesia	James-Lange	frontal
facilitation	flexion	overlapping

REFERENCES

On imagery, synesthesia, etc., see Galton's *Inquiries into Human Faculty and Its Development*, 1883, pp. 57-112; and for more recent studies of imagery see G. H. Betts on *The Distribution and Function of Mental Imagery*, 1909, and Mabel R. Fernald on *The Diagnosis of Mental Imagery*, 1912.

On the diagnostic use of the association test, an extensive work is that of C. G. Jung, *Studies in Word-Association*, translated by Eder, 1919.

CHAPTER XVI

THE LAWS OF ASSOCIATION

AN ATTEMPT TO REDUCE THE LEARNING PROCESS TO ITS ELEMENTS

This is a very serious occasion. What we now have before us is one of the great outstanding problems of psychology, a problem that has come down through the ages, with succeeding generations of psychological thinkers contributing of their best to its solution; and our task is to attack this problem afresh in the light of modern knowledge of the facts of learning and memory. We wish to gather up the threads from the three preceding chapters, which have detailed many facts regarding learned reactions of all sorts, and see whether we cannot summarize our accumulated knowledge in the form of a few great laws. We wish also to relate our laws to what is known of the brain machinery.

THE LAW OF EXERCISE

Of one law of learning, we are perfectly sure. There is no doubt that the exercise of a reaction strengthens it, makes it more precise and more smooth-running, and gives it an advantage over alternative reactions which have not been exercised. Evidence for these statements began to appear as soon as we turned the corner into this part of our subject, and has accumulated ever since. This law is sometimes called the "law of habit", but might better be called the "law of improvement of a reaction through exercise", or, more briefly, the "law of exercise".

The law of exercise is very broad in its scope, holding good of life generally and not alone of mental life. Exercise of a muscle develops the muscle, exercise of a gland develops the gland; and, in the same way, exercise of a mental reaction strengthens the machinery used in making that reaction.

Let us restate the law in terms of stimulus and response. *When a given stimulus arouses a certain response, the linkage between that stimulus and that response is improved by the exercise so obtained, and thereafter the stimulus arouses the response more surely, more promptly, more strongly than before.*

Under the law of exercise belong several *sub-laws* already familiar to us.

1. The law of *frequency* refers to the cumulative effect of repeated exercise. The practice curve gives a picture of this sub-law, showing how improvement with repeated exercise of a performance is rapid at first and tapers off into the physiological limit, beyond which level more repetition cannot further improve the performance. The superiority of "spaced study" over unspaced means that exercise is more effective when rest periods intervene between the periods of exercise; as this is notoriously true of muscular exercise, it is not surprising to find it true of mental performances as well.

2. The law of *recency* refers to the gradual weakening of the machinery for executing a reaction when no longer exercised; it is the general biological law of "atrophy through disuse" applied to the special case of learned reactions. As exercise improves the linkage between stimulus and response, so disuse allows the linkage to deteriorate. This law is pictured more completely and quantitatively in the curve of forgetting.

Really, there are two laws of recency, the one being a

law of retention, the other a law of momentary warming up through exercise. The law of retention, or of forgetting, is the same as atrophy through disuse. The warming-up effect, well seen in the muscle which is sluggish after a long rest but becomes lively and responsive after a bit of exercise,¹ appears also in the fact that a skilled act needs to be done a few times in quick succession before it reaches its highest efficiency, and in the fact of "primary memory", the lingering of a sensation or thought for a few moments after the stimulus that aroused it has ceased. Primary memory is not strictly memory, since it does not involve the recall of facts that have dropped out of mind, but just a new emphasis on facts that have not yet completely dropped out. Warming up is not a phenomenon of learning, but it is a form of recency, and is responsible for the very strong "recency value" that is sometimes a help in learning,² and sometimes a hindrance in recall.³

3. The law of *intensity* simply means that vigorous exercise strengthens a reaction more than weak exercise. This is to be expected, but the question is, in the case of mental performances, how to secure vigorous exercise. Well, by active recitation as compared with passive reception, by close attention, by high level observation. In active recitation, the memorizer strongly exercises the performance that he is trying to master, while in reading the lesson over and over he is giving less intense exercise to the same performance.

THE LAW OF EFFECT

We come now to a law which has not so accepted a standing as the law of exercise, and which may perhaps be another sub-law under that general law. The "law of effect" may, however, be regarded simply as a generalized statement of

¹ See p. 73.

² See p. 345.

³ See p. 356.

the facts of learning by trial and error. The cat, in learning the trick of escaping from a cage by turning the door-button, makes and therefore exercises a variety of reactions; and you might expect, then, in accordance with the law of exercise, that all of these reactions would be more and more firmly linked to the cage-situation, instead of the successful reaction gradually getting the advantage and the unsuccessful being eliminated. The law of effect, stated as objectively as possible, is simply that the successful or unsuccessful outcome or *effect* of a reaction determines whether it shall become firmly linked with the stimulus, or detached from the stimulus and thus eliminated. *The linkage of a response to a stimulus is strengthened when the response is a success, and weakened when the response is a failure.*

Success here means reaching the goal of an awakened desire or *reaction-tendency*, and failure means being stopped or hindered from reaching the goal. Since success is satisfying and failure unpleasant, the law of effect is often stated in another form: a response that brings satisfaction is more and more firmly attached to the situation and reaction-tendency, while a response that brings pain or dissatisfaction is detached.

The law of effect is a statement of fact, but the question is whether it is an ultimate fact, or whether it can be explained as a special case of the law of exercise. Some have suggested that it is but a special case of the sub-law of frequency; they call attention to the fact that the successful response must be made at every trial, since the trial continues till success is attained, whereas no one unsuccessful response need be made at every trial; therefore in the long run the successful response must gain the frequency advantage. But there is a very ready and serious objection to this argument; for it may and does happen that an unsuccessful response is repeated several times during a single

trial, while the successful response is never made more than once in a single trial, since success brings the trial to a close; and thus, as a matter of fact, frequency often favors the unsuccessful response—which, nevertheless, loses out in competition with the successful response.

Can the law of effect be interpreted as an instance of the sub-law of recency? The successful reaction always occurs at the end of a trial, and is the most recent reaction at the beginning of the next trial. This recency might have considerable importance if the next trial began instantly (as in unspaced learning), but can have no importance when so long an interval as a day is left between trials; for evidently the recency of twenty-four hours plus ten seconds is not effectively different from that of an even twenty-four hours. Recency, then, does not explain the law of effect.

Can it be explained as an instance of the sub-law of intensity? An animal, or man, who sees success coming as he is making the reaction that leads directly to success, throws himself unreservedly into this reaction, in contrast with his somewhat hesitant and exploratory behavior up to that time. The dammed-up energy of the reaction-tendency finds a complete outlet into the successful reaction, and therefore the successful reaction is more intensely exercised than the unsuccessful. This seems like a pretty good explanation, though perhaps not a complete explanation.

LIMITATIONS OF THE LAW OF EXERCISE

The law of exercise, with all its sub-laws, is certainly fundamental and universal; it is always in operation whenever anything is learned; and yet, just by itself, it goes only halfway towards accounting for learned reactions. For a reaction to be exercised, it must be *made*, and the law of exercise presupposes that it is made, and does not attempt to account for its being made in the first place.

The law of exercise does not cover the formation of new linkages, but only the strengthening of linkages that are already working. It does not explain the attachment of a response to some other than its natural stimulus, nor the combination of responses into a higher unit, nor the association of two facts so that one later recalls the other. We learn by doing, but how can we do anything new so as to start to learn? We learn by observing combinations of facts, but how in the first place do we combine the facts in our minds?

How, for example, can we learn to respond to the sight of the person by saying his name? Evidently, by exercising this linkage of stimulus and response. But how did we ever make a start in responding thus, since there is nothing about the person's looks to suggest his name? The name came to us through the ear, and the face by way of the eye; and if we repeated the name, that was a response to the auditory stimulus and not to the visual. How has it come about, then, that we later respond to the visual stimulus by saying the name?

In short, the more seriously we take the law of exercise, the more we feel the need of a supplementary law to provide for the first making of a reaction that then, by virtue of exercise, is strengthened.

This is the problem that occupied the older writers on psychology when they dealt with "association": and their solution of the problem was formulated in the famous "laws of association". The laws of association were attempts to explain how facts got associated, so that later one could recall another.

These laws have a long history. From Aristotle, the ancient Greek who first wrote books on psychology, there came down to modern times four laws of association. Facts become associated, according to Aristotle, when they are

contiguous (or close together) in space, or when they are contiguous in time, or when they resemble each other, or when they contrast with each other. The psychologists of the earlier modern period, in the eighteenth and first part of the nineteenth centuries, labored with very good success to reduce these four laws to one comprehensive law of association. Contiguity in space and in time were combined into a law of association by *contiguity in experience*, since evidently mere physical contiguity between two objects could establish no association between them in any one's mind except as he experienced them together.

ASSOCIATION BY SIMILARITY

Continuing their simplification of the laws of association, these older psychologists showed that resemblance and contrast belonged together, since to be similar things must have something in common, and to be contrasted also two things must have something in common. You contrast north with south, a circle and a square, an automobile and a wheelbarrow; but no one thinks of contrasting north with a circle, south with an automobile, or a square and a wheelbarrow, though these pairs are more incongruous than the others. Things that are actually associated as contrasting with each other have something in common; and therefore association by contrast could be included under association by similarity. Thus the four laws had been reduced to two, association by contiguity and association by similarity.

The final step in this reduction was to show that association by similarity was a special case of association by contiguity. To be similar, two things must have something in common, and this common part, being contiguous with the remainder of each of the two things, establishes an indirect contiguity between the two things, a

sort of contiguity bridge between them. One thing has the parts or characteristics, A B X Y, and the similar thing has the parts or characteristics, C D X Y; and thus X Y, when seen in the second thing, call up A B, with which they are contiguous in the first thing.

A stranger reminds me of my friend because something in the stranger's face or manner has been met with before in my friend; it has been contiguous with my friend, and recalls him by virtue of this contiguity. The stranger, as a whole individual, has never been contiguous with my friend, but some characteristic of the stranger has been thus contiguous. In association by similarity, it is not the whole present object that arouses recall of the similar object, but some *part* of the present object. This kind of association is important in thinking, since it brings together facts from different past experiences, and thus assembles data that may be applied to a new problem. If every new object or situation could only be taken as a whole, it could not remind me of anything previously met; and I should be like an inexperienced child in the presence of each new problem; but, taken part by part, the novel situation has been met with before, and can be handled in the light of past experience.

Exactly what there is in common between two similar faces or other objects cannot always be clearly made out; but the common characteristic is there, even if not consciously isolated, and acts as an effective stimulus to recall.

ASSOCIATION BY CONTIGUITY

This reduction of all the laws of association to one great law was no mean achievement; and the law of association by contiguity in experience holds good. If one thing recalls another to your mind, you can be sure that the two

have been contiguous in your experience, either as wholes or piecemeal. For two things to become associated, they must be experienced together.

Yes, the law holds good, when thus stated—but notice that the statement is virtually negative. It says, in effect, that two things do *not* become associated *unless* they are contiguous in experience. If it were turned about to read that two things do become associated if they are contiguous in experience, it would no longer be a true law, for the exceptions would then be extremely numerous.

The memory and testimony experiments have brought many exceptions to light. Show a person twenty pictures in a row, and let him examine each one in turn so closely that he can later recognize every one of them; and still he will not have the adjacent pictures so associated that each one can call up the next in order. To accomplish his last task, he has to observe the order specifically; it is not enough that he simply experiences pictures together. Or, again, read to a person twenty pairs of words, asking him to notice the pairs so that later he can respond by the second word of any pair when the first word is given him; and read the list through three or four times, so that he shall be able to make almost a perfect score in the expected test; still he will have formed few associations between the contiguous pairs, and will make a very low score if you ask him to recite the pairs in order. Many similar experiments have yielded the same general result—contiguity in experience and still no association.

The law of association by contiguity is unsatisfactory from a modern standpoint because it treats only of the stimulus, and says nothing about the response. It states, quite truly, that stimuli must be contiguous in order that an association between them may be formed, but it neglects to state that the association, being something *in us*, must

be formed by our reaction to the stimuli. It is especially necessary to consider the response because, as we have just seen, the response is not always made and the association, therefore, not always formed. Only if the stimuli are contiguous, can the associating response be aroused, but they do not infallibly arouse it even if they are contiguous.

The law of contiguity is incomplete, also, because it is not applicable to the association of two motor acts into a coördinated higher unit, or of the combination of two primary emotions into a higher emotional unit.

In a word, the time-honored law of association is no longer satisfactory because it does not fit into a stimulus-response psychology. It comes down from a time when the motor side of mental performances was largely overlooked by psychology, and when the individual was pictured as being passively "impressed" with the combinations of facts that were presented to his senses.

THE LAW OF COMBINATION

What we need, then, as an improvement on the old law of association by contiguity, and as a supplement to the law of exercise, is some law governing the response to two or more contiguous stimuli. Now we already have such a law, which we put to some use in studying attention,¹ and called the law of "combination", or of "unitary response to a plurality of stimuli". We had better fetch that law out again and put it in good repair, and see whether it is adequate for the job that we now have on hand. In a very general, abstract form, the law of combination read that "two or more stimuli may arouse a single joint response". Let us add a single word, which had not risen above the horizon when we formulated the law before, and say that

¹ See pp. 263-264.

two or more contiguous stimuli may arouse a single joint response.

That seems very little to say; can we possibly go far with so simple a statement? Well, let us see. In saying that two or more stimuli arouse a single response, we imply that *there is already some rudimentary linkage between each stimulus and their common response, and that this linkage is used in arousing the response.* Now bring in our trusty law of exercise, and we see that the use, or exercise, of such a linkage may strengthen it to such an extent that, *later, a single one of the stimuli may arouse the response which was originally aroused by the whole collection of stimuli.*

Does that promise any better? Probably it requires further discussion and exemplification before its value can be appreciated. Let us, then, first discuss it a bit, and then apply it to the explanation of the chief varieties of learned reaction that have come to our attention.

The law of combination attempts to show how it comes about that a stimulus, originally unable to arouse a certain response, acquires the power of arousing it; and the law states that this occurs only when the originally ineffective stimulus is combined with others which can and do arouse the response. The ineffective stimulus, being one of a combination of stimuli which collectively arouse the response, participates to some slight degree in arousing that response and may thus become effectively linked with the response.

Notice an assumption underlying the law of combination. Evidently a stimulus could not take part in arousing a response unless there were some pre-existing linkage between it and the response. This linkage may however be extremely loose and feeble, and wholly incapable by itself of arousing the response. The assumption of pre-existing loose linkage between almost any stimulus and almost any response is justified by the facts of playful behavior and trial and error

behavior. In addition to the close reflex connections provided in the native constitution, and in addition also to the close connections formed in previous training, there are at any time, and especially in childhood and youth, a vast number of loose connections. These are too weak to operate singly, until they have coöperated in producing a response, and thus been individually strengthened, after which they may be able singly to produce the response.

The law of combination, then, as applied to learning, includes four points:

(a) A collection of stimuli may work together and arouse a single response.

(b) This is possible because of pre-existing loose linkage between the separate stimuli and the response.

(c) When any stimulus, working together with others, helps to arouse a response, its linkage with that response is strengthened by exercise.

(d) The linkage may be sufficiently strengthened so that a single stimulus can arouse the response without help from the other stimuli that were originally necessary.

Having now abundantly stated and reiterated the law of combination in the abstract, let us turn to concrete instances of learned reactions, and see how the law takes care of them. We have already classified a large share of all the concrete instances under a few main heads, as substitute stimulus, substitute response, combination (or association) of stimuli, and combination of responses. We shall presently find it possible to reduce these four classes to two, since the association of two objects, by virtue of which one of them later recalls the other, is a rather complicated case of substitute stimulus, while the combination of movements into a higher unit is a complicated case of substitute response.¹

¹ To distinguish between "substitute stimulus" and "substitute response" is, in strict logic, like distinguishing between "inside out" and

I. SUBSTITUTE STIMULUS EXPLAINED BY THE LAW OF COMBINATION

Here the response, without being itself essentially changed, becomes attached to a new stimulus. We distinguish two cases under the general head of substitute stimulus. In the one case, the substitute stimulus was originally extraneous, and unnecessary for arousing the response, while in the other case it was originally necessary as part of a team of stimuli that aroused the response.

A. SUBSTITUTE STIMULUS ORIGINALLY UNNECESSARY FOR AROUSING THE RESPONSE

I. **Conditioned reflex.** This is the very simplest case belonging under the law of combination. The dog that responded to the bell by a flow of saliva, after the bell *plus* a tasting substance had acted together on him time after time, is the typical instance; and another good instance is that of the little child who was "taught" to shrink from a rabbit by the sounding of a harsh noise along with the showing of the rabbit.¹ The explanation of all instances of conditioned reflex is the same. We have an effective stimulus acting, i.e., a stimulus strongly linked with the response; and we also have acting an ineffective stimulus, which gets drawn into the same reaction. The effective stimulus determines what response shall be made, and the other stimulus finds an outlet

"outside in." Whenever there is a substitute stimulus there is also a substitute response, of course, since this stimulus, in being substituted for another, gets that other's response in place of its own original response; and in the same way, you can always find substitute stimulus in any instance of substitute response; for, in being substituted for another, a response gets that other's stimulus in place of its own original stimulus. For all that, the distinction between the two main cases of learning is of some importance, since sometimes the changed stimulus, and sometimes the changed response, is the interesting fact.

¹ See p. 303.

into that response, being, as it seems, attracted towards the activated response, sucked into it. The weak linkage from the ineffective stimulus to the response, being thus used and strengthened, later enables this stimulus to arouse the response single-handed.

This sort of thing is best presented in a diagram. A full line in the diagram denotes a linkage strong enough to work alone, while a dotted line denotes a weak linkage. Letters stand for stimuli and responses. In the diagram for conditioned reflex, A is the original effective stimulus (the rasping noise in the instance of the child and the rabbit), and B is the ineffective stimulus (the sight of the rabbit). R is the shrinking response, linked strongly to the stimulus A and only weakly to the stimulus B, which has several other



FIG. 55.—Attachment of the substitute stimulus in the case of the conditioned reflex.

linkages fully as good as the linkage B-R. But A arouses the response R; and R, being thus activated, draws on B and brings the linkage B-R into use. After this has occurred a number of times, the linkage B-R has been so strengthened by repeated exercise that it can operate alone, so that the rabbit brings the shrinking response even in the absence of A, the noise.

At first, the child shrinks from the noise, but, the rabbit being before his eyes, he incidentally shrinks from the rabbit as well. He really shrinks in response to all the stimuli acting on him at that moment. He shrinks from the whole situation. He makes a unitary response to the whole collection of contiguous stimuli, and thus exercises the linkage between each stimulus and their joint response. The

linkage between rabbit and shrinking is later strong enough to work alone. It is a clear case of the law of combination.

2. **Learning the names of things.** A child who can imitate simple words that he hears is shown a penny and the word "penny" is spoken to him. To this combination of stimuli he responds by saying the word. This is primarily a response to the auditory stimulus, since the sight of the penny, though it might probably have aroused some response, and even some vocal response from the child, had no strong linkage with this particular vocal response. But the auditory stimulus determined the response, and attracted the visual stimulus into this particular channel of saying "penny". The linkage from the sight of the penny to the saying of

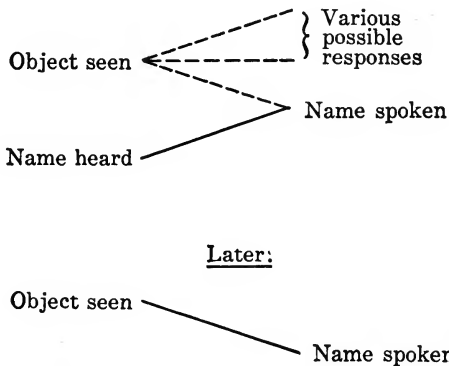
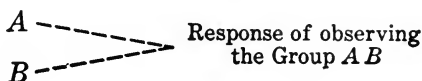

FIG. 56.—Linkage of a name to an object. The diagram is arranged to illustrate the formation of a linkage from the sight of the object to saying its name. A very similar diagram would illustrate the linkage from the name to the thought or image of the object. The acquiring of mental images seems to be essentially the same process as the acquiring of conditioned reflexes, and of names.

this word being thus strengthened by exercise, the seen penny later gives the right vocal response, without any auditory stimulus to assist.

B. SUBSTITUTE STIMULUS ORIGINALLY AN ESSENTIAL MEMBER
OF A TEAM OF STIMULI THAT AROUSED THE RESPONSE

I. Observed grouping or relationship. "Learning by observation" is a very important human accomplishment, and we found many evidences of its importance in our study of the process of memorizing. The facts observed, which assist memory so greatly, are usually relations or groups.



Later:

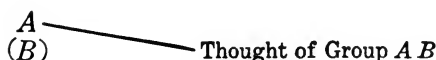

FIG. 57.—The formation of an association between two objects by observing their grouping or relationship.

Evidently the observation of a group of things is a response to a collection of stimuli, and could not originally be aroused by any one of the stimuli alone. The same is true of observing a relationship; the observation is a response to two things taken together, and not, originally, to either of the two things taken alone. In spite of this, a single one of the things may later call to mind the relationship, or the group; that is, it arouses the response originally made to the pair or group of stimuli. The single stimulus has been substituted for the team that originally aroused the response. Its linkage with the response has been so strengthened by exercise as to operate effectively without assistance.

For example, in learning pairs of words in a "paired

associates experiment",¹ the subject is apt to find some relation between the words forming a pair, even though they are supposed to be "unrelated words". When he has thus learned the pair, either of the words in it will recall the observed relation and the other word of the pair. Sometimes, after a long interval especially, the relation is recalled without the other word. One subject fixed the pair, "windy—occupy", by thinking of a sailor occupying a windy perch up in the ropes. Some weeks later, on being given the word "windy", he recalled the sailor on the perch, but could not get the word "occupy". That is, he made the same response to "windy" that he had originally made to "windy—occupy", but did not get the response completely enough to give the second word.

In the typical cases of *association by contiguity*, when one object reminds us of another that was formerly experienced together with it, the law of combination comes in as just described. The two objects were observed to be grouped or related in some way, or some such unitary response was made to the two objects taken together, and this response became so linked to each of the objects that later a single one of them arouses this unitary response and recalls the other object. In the free association test,² the stimulus word "dimple" calls up the previously made response of seeing a dimple in a cheek, and so leads to the word "cheek". In a controlled association test, where opposites are required, the stimulus word "mythical" arouses the previously made observation of the antithesis of mythical and historical, and so leads to the motor response of saying the latter word.³

¹ See p. 336.

² See p. 380.

³ When, however, this indirect linkage between stimulus and motor response is frequently exercised, short-circuiting takes place (see p. 338), and the stimulus word arouses the motor response directly. Short-

2. Response by analogy and association by similarity.

When an object reminds me of a similar object, that is association by similarity. But suppose I actually take the object to be the similar object, and behave towards it accordingly; then my reaction is called "response by analogy". Once, when far from home, I saw a man whom I took to be an acquaintance from my home town, and stepped up to him, extending my hand. He did not appear very enthusiastic, and informed me that, in his opinion, I had made a mistake. This was response by analogy, but if I had simply said to myself that that man looked like my acquaintance, that would have been association by similarity. Really, association by similarity is the more complex response, for it involves response to the points of newness in the present object, as well as to the points of resemblance to the familiar object, whereas response by analogy consists simply in responding to the points of resemblance.

Response by analogy often appears in little children, as when they call all men "papa", or as when they call the squirrel a "kitty" when first seen. If they call it a "funny kitty", that is practically association by similarity, since the word "funny" is a response to the points in which a squirrel is different from a cat, while the word "kitty" is a response to the points of resemblance.

But response by analogy is not always so childish or comic as the above examples might seem to imply. When we respond to a picture by recognizing the objects depicted, that is response by analogy, since the pictured object is only

circuiting follows the law of combination very nicely. Let a stimulus S arouse an idea I and this in turn a motor act M. S—I—M represents the linkages used. But undoubtedly there is a weak pre-existing linkage directly across from S to M, and this gets used to a slight degree, strictly according to the conditioned reflex diagram, with I playing the part of the effective stimulus in arousing M, and S the part of the originally ineffective stimulus. By dint of being exercised in this way, the linkage S—M becomes strong enough to arouse the motor response directly, and I is then very likely to be left out altogether.

a little birdy bow wow



partially like the real object; a bare outline drawing may be enough to arouse the response of "seeing" the object. Other instances of response by analogy will come to light

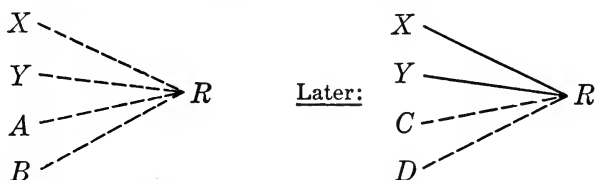

FIG. 58.—Response by analogy. The letters, *A*, *B*, *X*, *Y*, represent the several stimuli that make up the original object, and each of them becomes well linked with their common response (seeing the object, and perhaps naming it). When the linkage between *X* and *Y* and the response has become strong, a similar object, presenting *X* and *Y* along with other new stimuli, *C* and *D*, appears, and arouses the old response, by virtue of the now-effective linkage from *X* and *Y* to this response.

when, in the next chapter, we come to the study of perception.

The machinery of response by analogy is easily understood by aid of the law of combination. A complex object,

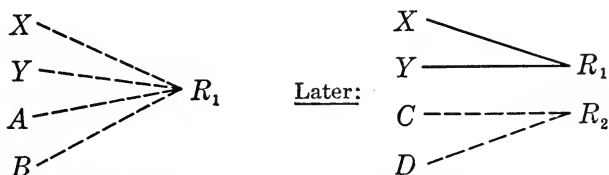

FIG. 59.—Association by similarity. Everything here as in the previous diagram, except that *C* and *D* get a response in addition to that aroused by *X* and *Y*, and so the new object is seen to be new, while at the same time it recalls the old object to mind.

presenting a number of parts and characteristics, arouses the response of seeing and perhaps naming the object. This is a unitary response to a collection of stimuli, and each of the parts or characteristics of the object participates in arousing the response, and the linkage of each part with the response is thus strengthened. Later, therefore, the whole identical object is not required to arouse this same

response, but some of its parts or characteristics will give the response, and they may do this even when they are present in an object that has other and unfamiliar parts and characteristics.

The machinery of association by similarity is the same, with the addition of a second response, called out by the new characteristics of the present object.

II. SUBSTITUTE RESPONSE EXPLAINED BY THE LAW OF COMBINATION

The substitute response machinery is more complicated than that of the substitute stimulus, as it includes the latter and something more. What that something more is will be clear if we ask ourselves why a substitute response should ever be made. Evidently because there is something wrong with the original response; if that were entirely satisfactory, it would continue to be made, and there would be no room for a substitute. The original response being unsatisfactory to the individual, how is he to find a substitute? Only by finding some stimulus that will arouse it. This is where trial and error come in, consisting in a search for some extra stimulus that shall give a satisfactory response.

Suppose now that the extra stimulus has been found which arouses a satisfactory substitute response. The original stimulus, or the reaction-tendency aroused by it, still continuing, participates in arousing the substitute response, playing the part of the originally ineffective stimulus in the conditioned reflex. Thus the original stimulus becomes strongly linked with the substitute response.

The process of reaching a substitute response thus includes three stages: (a) original response found unsatisfactory, (b) new stimulus found which gives a satisfactory substitute response, (c) attachment of the substitute response to the original stimulus.

There are two main cases under the general head of substitute response. In one case, the substitute response is essentially an old response, not acquired during the process of substitution, but simply substituted, as indicated just above, for the original response to the situation. This represents the common trial and error learning of animals. The second case is that where the substitute response has to be built up by combination of old responses into a higher unit.

C. SUBSTITUTE RESPONSE, BUT NOT IN ITSELF A NEW RESPONSE

1. **Trial and error.** Our much-discussed instance of the *cat in the cage* need not be described again, but may simply be illustrated by a diagram.

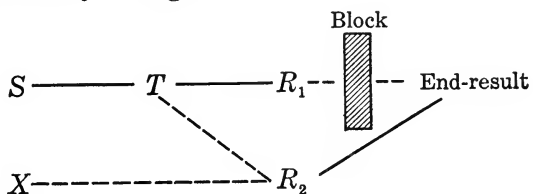

Later:

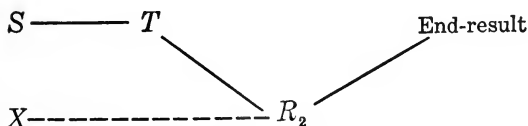

FIG. 60.—How the cat learns the trick of escaping from the cage by unlatching the door. *S* is the situation of being shut up in a cage, and *T* is the tendency to get out. *R*₁ is the primary response aroused by this tendency, which response meets with failure, not leading to the end-result of the tendency. Responses are then made to various particular stimuli about the cage, and one of these stimuli, the door-latch, *X*, gives the response *R*₂ which leads to the end-result. Now the response *R*₂ was in part aroused by *T*, and its pre-existing weak linkage with *T* is so strengthened by exercise that *T*, or we may say *S*, comes to give the correct response without hesitation.

2. **Learning to balance on a bicycle.** When the beginner feels the bicycle tipping to the left, he naturally responds by leaning to the right, and even by turning the wheel to the right. Result unsatisfactory—strained position and further tipping to the left. As the bicyclist is about to fall, he saves himself by a response which he has previously learned in balancing on his feet; he extends his foot to the left, which amounts to a response to the ground on the left as a good base of support. Now let him sometime respond to the ground on his left by turning his wheel that way, and, to his surprise and gratification, he finds the tipping overcome, and his balance well maintained. The response of turning to the left, originally made to the ground on the left (but in part to the tipping), becomes so linked with the tipping as to be the prompt reaction whenever tipping is felt. The diagram of this process would be the same as for the preceding instance.

D. **SUBSTITUTE RESPONSE, THE RESPONSE BEING A HIGHER MOTOR UNIT**

1. **The brake and clutch combination in driving an automobile.** This may serve as an instance of *simultaneous coördination*, since the two movements which are combined into a higher unit are executed simultaneously. The beginner in driving an automobile often has considerable trouble in learning to release the "clutch", which, operated by the left foot, un gears the car from the engine, and so permits the car to be stopped without stopping the engine. The foot brake, operated by the right foot, is comparatively easy to master, because the necessity for stopping the car is a perfectly clear and definite stimulus. Now, when the beginner gets a brake-stimulus, he responds promptly with his right foot, but neglects to employ his left foot on the clutch, because he has no effective clutch-stimulus; there is nothing

in the situation that reminds him of the clutch. Result, engine stalled, ridicule for the driver. Next time, perhaps, he *thinks* "clutch" when he gets the brake-stimulus, and this thought, being itself a clutch-stimulus, arouses the clutch-response simultaneously with the brake-response. After doing this a number of times, the driver no longer needs the thought of the clutch as a stimulus, for the left foot

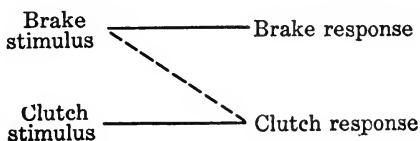

Later:

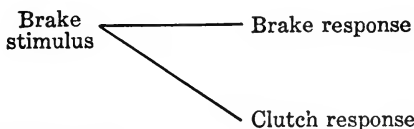

FIG. 61.—Combining clutch-response with brake-response. At first, the brake-stimulus has only a weak linkage with the clutch-response, and an extra stimulus has to be found to secure the clutch-response. But whenever the clutch-response is made while the brake-stimulus is acting, the weak linkage between these two is exercised, till finally the brake-stimulus is sufficient to give the clutch-response, along with the brake-response.

movement on the clutch has become effectively linked with the brake-stimulus, so that any occasion that arouses the brake-response simultaneously arouses the clutch response.

The combination of two responses is effected by linking both to the same stimulus; thus the two become united into a coördinated higher motor unit.

2. **The word-habit in typewriting** furnishes an example of *successive coördination*, the uniting of a sequence of movements into a higher unit.¹ The beginner has to spell out

¹ See p. 324.

the word he is writing, and make a separate response to each letter; but when he has well mastered the letter-habits, and, still unsatisfied, is trying for more speed, it happens that he thinks ahead while writing the first letter of a word, and *prepares* for the second letter. In effect, he commences reacting to the second letter while still writing the first.

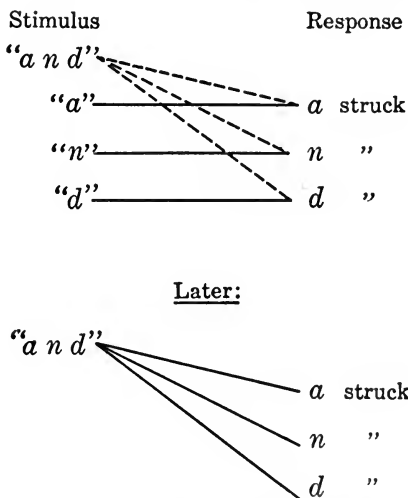

FIG. 62.—Learning a word-habit in typewriting. At first, besides the stimulus of the word, "and," it is necessary also to have the stimulus "a" in order to arouse the response of writing a, the stimulus "n" in order to arouse the writing of n, and the stimulus "d" in order to arouse the writing of d. Yet the stimulus "and" is present all this time, and its weak linkages with the writing movements are used and strengthened, so that finally it is sufficient, by itself, to arouse the whole series of writing movements.

This goes further, till he anticipates the series of letters forming a short word while still at the beginning of the word. The letter movements are thus linked to the thought of the word as a whole, and the word becomes an effective stimulus for arousing the series of letter movements.

Many other instances of learning can be worked out in the same way, and there seems to be no difficulty in inter-

preting any of them by the law of combination. Even "negative adaptation" can possibly be interpreted as an instance of substitute response; some slight and easy response may be substituted for the avoiding reaction or the attentive reaction that an unimportant stimulus at first arouses, these reactions being rather a nuisance when they are unnecessary. On the whole, the law of combination seems to fill the bill very well. It explains what the law of exercise left unexplained. It always brings in the law of exercise as an ally, and, in explaining substitute response, it brings in the law of effect, which however, as we saw before, may be a sub-law under the law of exercise. These two, or three laws, taken together, give an adequate analysis of the whole process of learning.

THE LAW OF COMBINATION IN RECALL

Unitary response to multiple stimuli is important in recall as well as in learning. The clearest case of this is afforded by "controlled association".¹

In an opposites test, the response to the stimulus word "long" is aroused partly by this stimulus word, and partly by the "mental set" for opposites. There are two lines of influence, converging upon the response, "long—short" (of which only the word "short" may be spoken): one line from the stimulus word "long", and the other from the mental set for pairs of opposite words. The mental set for opposites tends to arouse any pair of opposites; the word "long" tends to arouse any previously observed group of words of which "long" is a part. The mental set, an internal stimulus, and the stimulus word coming from outside, converge or combine to arouse one particular response.

The mental set for adding has previously exercised link-

¹ See p. 381.

ages with the responses composing the addition table, while the mental set for multiplication has linkages with the responses composing the multiplication table. When the set for adding is active, a pair of numbers, seen or heard, together with this internal stimulus of the mental set, arouses the response that gives the sum; but when the multiplying set is active, the same pair of numbers gives the product as the response. All thinking towards any goal is a similar instance of the law of combination.

THE LAWS OF LEARNING IN TERMS OF THE NEURONE

We have good evidence that the brain is concerned in learning and retention. Loss of some of the cortex through injury often brings loss of learned reactions, and the kind of reactions lost differs with the part of the cortex affected. Injury in the occipital lobe brings loss of visual knowledge, and injury in the neighborhood of the auditory sense-center brings loss of auditory knowledge.

Injury to the retina or optic nerve, occurring early in life, results in an under-development of the cortex in the occipital lobe. The nerve cells remain small and their dendrites few and meager, because they have not received their normal amount of exercise through stimulation from the eye.

Exercise, then, has the same general effect on neurones that it has on muscles; it causes them to grow and it probably also improves their internal condition so that they act more readily and more strongly. The growth, in the cortex, of dendrites and of the end-brushes of axons that interlace with the dendrites, must improve the synapses between one neurone and another, and thus make better conduction paths between one part of the cortex and another, and also between the cortex and the lower sensory and motor centers.

The law of exercise has thus a very definite meaning when

translated into neural terms. It means that the synapses between stimulus and response are so improved, when traversed by nerve currents in the making of a reaction, that nerve currents can get across them more easily the next time. The more a synapse is used, the better synapse it

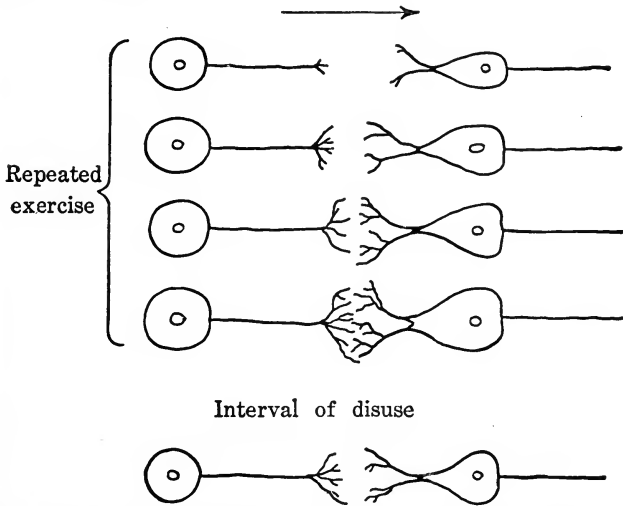

FIG. 63.—The law of exercise in terms of synapse. A nerve current is supposed to pass along this pair of neurones in the direction of the arrow. Every time it passes, it exercises the end-brush and dendrites at the synapse (for the "passage of a nerve current" really means activity on the part of the neurones through which it passes), and the after-effect of this exercise is growth of the exercised parts, and consequent improvement of the synapse as a linkage between one neurone and the other. Repeated exercise may probably bring a synapse from a very loose condition to a state of close interweaving and excellent power of transmitting the nerve current.

becomes, and the better linkage it provides between some stimulus and some response. The cortex is the place where linkages are made in the process of learning, and it is there also that forgetting, or atrophy, takes place through disuse. Exercise makes a synapse closer, disuse lets it relapse into a loose and poorly conducting state.

The law of combination, also, is readily translated into

neural terms. The "pre-existing loose linkages" which it assumed to exist undoubtedly do exist in the form of "association fibers" extending in vast numbers from any one part of the cortex to many other parts. These fibers are provided by native constitution, but probably terminate rather loosely in the cortex until exercise has developed them. They may be compared to telephone wires laid down in the cables through the streets and extending into the houses,

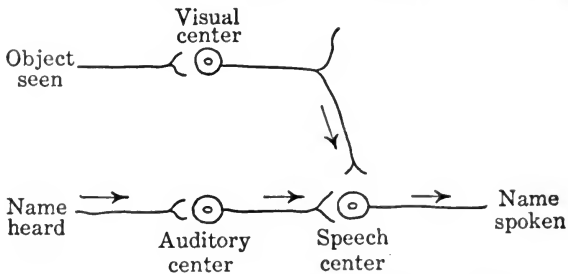

FIG. 64.—Diagram for the learning of the name of an object, transformed into a neural diagram. The vocal movement of saying the name is made in response to the auditory stimulus of hearing the name, but when the neurone in the "speech center" is thus made active, it takes up current also from the axon that reaches it from the visual center, even though the synapse between this axon and the speech neurone is far from close. This particular synapse between the visual and the speech centers, being thus exercised, is left in an improved condition. Each neurone in the diagram represents hundreds in the brain, for brain activities are carried on by companies and regiments of neurones.

but still requiring a little fine work to attach them properly to the telephone instruments.

The diagrams illustrating different cases under the law of combination can easily be perfected into neural diagrams, though, to be sure, any diagram is ultra-simple as compared with the great number of neurones that take part in even a simple reaction.

The reader will be curious to know now much of this neural interpretation of our psychological laws is observed fact, and how much speculation. Well, we cannot as yet

observe the brain mechanism in actual operation—not in any detail. We have good evidence, as already outlined, for growth of the neurones and their branches through exercise. We have perfectly good evidence of the law of “unitary response to multiple stimuli” from the physiologi-

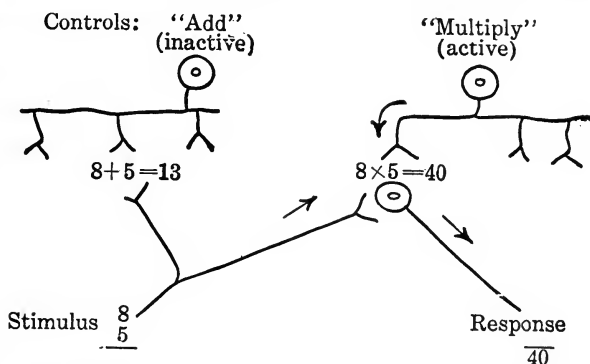

FIG. 65.—Control, in multiplying. The visual stimulus of two numbers in a little column, has preformed linkages both with the adding response and with that of multiplying. But the mental set for adding being inactive at the moment, and that for multiplying active (because the subject means to multiply), the multiplying response is facilitated.

cal study of reflex action; and we have perfectly good anatomical evidence of the convergence and divergence of neural paths of connection, as required by the law of combination. The association fibers extending from one part to another of the cortex are an anatomical fact.¹ Facilitation is a fact, and that means that a stimulus which could not of itself arouse a response can cooperate with another stimulus that has a direct connection with that response, and reinforce its effect. In short, all the elements required for a neural law of combination are known facts, and the only matter of doubt is whether we have built these elements together aright in our interpretation. It is not pure speculation, by any means.

¹ See p. 56.

EXERCISES

1. Outline the chapter, in the form of a list of laws and sub-laws.
2. Review the instances of learning cited in Chapters XIII-XV, and examine whether they are covered and sufficiently accounted for by the general laws given in the present chapter.
3. Draw diagrams, like those given in this chapter, for the simpler cases, at least, that you have considered in question 2.
4. Show that response by analogy is important in the development of language. Consider metaphor, for example, and slang, and the using of an old word in a new sense (as in the case of "rail-road").

REFERENCES

William James devoted much thought to the problem of the mechanism of learning, habit, association, etc., and his conclusions are set forth in several passages in his *Principles of Psychology*, 1890, Vol. I, pp. 104-112, 554-594, and Vol. II, pp. 578-592.

Another serious consideration of the matter is given by William McDougall in his *Physiological Psychology*, 1905, Chapters VII and VIII.

See also Thorndike's *Educational Psychology, Briefer Course*, 1914, Chapter VI.

On the whole subject of association, see Howard C. Warren, *A History of the Association Psychology*, 1921.

CHAPTER XVII

PERCEPTION

MENTAL LIFE CONSISTS LARGELY IN THE DISCOVERY
OF FACTS NEW TO THE INDIVIDUAL, AND IN THE
RE-DISCOVERY OF FACTS PREVIOUSLY OBSERVED

You will remember the case of John Doe, who was brought before us for judgment on his behavior, as to how far it was native and how far acquired. We have since that time been occupied in hearing evidence on the case, and after mature consideration have reached a decision which we may formulate as follows: that this man's behavior is primarily instinctive or native, but that new attachments of stimulus and response, and new combinations of responses, acquired in the process of learning, have furnished him with such an assortment of habits and skilled acts of all sorts that we can scarcely identify any longer the native reactions out of which his whole behavior is built. That decision being reached, we are still not ready to turn the prisoner loose, but wish to keep him under observation for a while longer, in order to see what use he makes of this vast stock of native and acquired reactions. We wish to know how an individual, so equipped, behaves from day to day, and meets the exigencies of life. Such, in brief, is the task we have still before us.

Accordingly, one fine morning we enter our prisoner's sleeping quarters, and find him, for once, making no use of his acquired reactions, as far as we can see, and utilizing but a small fraction of his native reactions. He is, in short, asleep. We ring a bell, and he stirs uneasily. We

ring again, and he opens his eyes sleepily upon the bell, then spies us and sits bolt upright in bed. "Well, what . . ." He throws into action a part of his rather colorful vocabulary. He evidently sees our intrusion in an unfavorable light at first, but soon relaxes a little and "supposes he must be late for breakfast". Seeing our stenographer taking down his remarks, he is puzzled for a moment, then breaks into a loud laugh, and cries out, "Oh! This is some more psychology. Well, go as far as you like. It must have been your bell I heard in my dream just now, when I thought I saw a lot of cannibals beating the tom-tom". Having now obtained sufficient data for quite a lengthy discussion, we retire to our staff room and deliberate upon these manifestations.

"The man perceives", we agree. "By the use of his eyes and ears he discovered facts, and interpreted them in the light of his previous experience. In knowing the facts, he also got adjusted to them and governed his actions by them. But notice—a curious thing—how his perception of the facts progressed by stages from the vague and erroneous to the correct and precise. Before he was fully awake, he mistook the bell for a tom-tom; then, more fully aroused, he knew the bell. Ourselves he first saw as mere wanton intruders, then as cheerful friends who wished him no ill; finally he saw us in our true character as investigators of his behavior."

Following our man through the day's work and recreation, we find a large share of his mental activity to consist in the perception of facts. We find that he makes use of the facts, adjusting himself to them and also shaping them to suit himself. His actions are governed by the facts perceived, at the same time that they are governed by his own desires. Ascertaining how the facts stand, he takes a hand and manipulates them. He is constantly coming to know

fresh facts, and constantly doing something new with them. His life is a voyage of discovery, and at the same time a career of invention.

Discovery and invention!—high-sounding words, still they are applicable to everyday life. The facts observed may not be absolutely new, but at least they have always to be verified afresh, since action needs always to take account of present reality. The invention may be very limited in scope, but seldom does an hour pass that does not call for doing something a little out of the ordinary, so as to escape from a fresh trap or pluck fruit from a newly discovered bough. All of our remaining chapters might, with a little forcing, be pigeonholed under these two great heads. Discovery takes its start with the child's instinctive exploratory activity, and invention with his manipulation, and these two tendencies, perhaps at bottom one, remain closely interlinked throughout.

SOME DEFINITIONS!

Perception is the culmination of the process of discovery. Discovery usually requires exploration, a search for facts; and it requires attention, which amounts to finding the facts or getting them effectively presented; and perception then consists in knowing the presented facts.

When the facts are presented to the senses, we speak of "sense perception". If they are presented to the eye, we speak of visual perception; if to the ear, of auditory perception, etc. But when we speak of a fact as being "presented" to the eye or ear, we do not necessarily mean that it is directly and completely presented; it may only be indicated. We may have before the eyes simply a *sign* of some fact, but perceive the fact which is the *meaning* of the sign. We look out of the window and "see it is wet to-day", though wetness is something to be felt rather than seen;

having previously observed how wet ground looks, we now respond promptly to the visual appearance by knowing the indicated state of affairs. In the same way, we say that we "hear the street car", though a street car, we must admit, is not essentially a noise. What we hear, in strictness, is a noise, but we respond to the noise by perceiving the presence of the car. Responding to a stimulus presented to one sense by perceiving a fact which could only be directly presented to another sense is exemplified also by such common expressions as that the stone "looks heavy", or that the bell "sounds cracked", or that the jar of fruit "smells sour". Sense perception, then, is responding to a stimulus by knowing some fact indicated by it either directly or indirectly.

Perception that is not sense perception occurs when the fact perceived is not even indirectly presented to the senses at the moment. The fact is then presented by recall; yet the fact in question is not recalled. Recall not only gives you facts previously perceived, but may provide the data, the stimulus, for fresh perception. Putting together two recalled facts, you may perceive a further fact not previously known. Remembering that you took your umbrella to the office this morning in the rain, that it was fine when you left the office, and that you certainly did not have the umbrella when you reached home, you perceive that you must have left it at the office. Reading in the paper of preparations for another polar expedition, and remembering that both poles have already been discovered, you perceive that there is something more in polar exploration than the mere race for the pole. Perception of this sort amounts to "reasoning", and will be fully considered in another chapter, while here we shall focus our attention on sense perception.

THE DIFFERENCE BETWEEN PERCEPTION AND SENSATION

If sense perception is a response to a sensory stimulus, so is sensation, and the question arises whether there is any genuine difference between these two. In the instance of "hearing the street car", the difference is fairly obvious; hearing the noise is sensation, while knowing the street car to be there is perception.

Sensation is the first response aroused by a stimulus, or at least the first response that is conscious. Perception is a second response, following the sensation, and being properly a direct response to the sensation and only an indirect response to the physical stimulus. The chain of events is: stimulus, response of the sense organ and sensory nerve, first cortical response which is sensation, second cortical response which is perception.

Conscious sensation is the response of the part of the cortex that first receives the nerve current from the sense organ stimulated, the response of the "sensory area" for the particular sense stimulated. When the eye is stimulated, the nerve current first reaches a small portion of the occipital lobe, called the visual sensory area. Without that area there is no visual sensation. When the ear is stimulated, the conscious sensation is the response of a small portion of the temporal lobe called the auditory sensory area, and without this area there is no auditory sensation. But the presence of the visual sensory area is not enough to give the visual perception of facts, nor is the presence of the auditory sensory area enough to give auditory perception. The cortical regions *adjacent* to the sensory areas are necessary for perception; if they are destroyed, the individual may still see, but not know the objects seen; or may still hear, but not recognize the words or tunes that he hears. If the cortical area destroyed is in the parietal

lobe, adjacent to the sensory area for the cutaneous and kinesthetic senses, he may still "feel" objects, but without being able to distinguish an apple from a lump of coal, or a folded newspaper from a tin pail.

Sense perception, then, is a response of ~~areas adjacent~~ to the sensory areas, and this response is aroused by nerve currents coming along "association fibers" from the sensory areas which are first aroused from the sense organs.

The whole chain of events, from the time the stimulus reaches the sense organ to the time the fact is perceived, occupies only a fifth or even a tenth of a second in simple cases, and the interval between the beginning of the sensation to the beginning of the perception is not over a twentieth when the fact is easily perceived. Since the sensation usually lasts for longer than this, it overlaps the perception in time, and the two conscious responses are so *blended* that it is difficult or impossible for introspection to separate them.

But when an unusual fact is presented, perception may lag, though sensation occurs promptly. We may be baffled and confused for an instant, and have sensation without any definite perception; or, more often, we make a rapid series of *trial and error perceptions*. In one instance, a noise was first heard as distant thunder, and then, correctly, as somebody walking on the floor above. In another case, a faint sound was first taken for a bird singing, then for a distant locomotive whistle, and finally for what it was, the tinny noise of a piece of metal carried in the hand and brushing against the overcoat as the person walked; this series occupied not over five seconds. On touching an object in the dark, you may feel it as one thing and another till some response is aroused that fits the known situation and so satisfies you. Such trial and error perception can be observed very frequently if one is on the watch for psy-

chological curiosities; and it justifies the distinction between sensation and perception, since the sensation remains virtually unchanged while perception changes.

Another sort of shifting perception is seen in looking steadily at the "ambiguous figures", which were considered in the chapter on attention, the cube, staircase, and others; and the "dot figures" belong here as well.¹ In these cases the stimulus arouses two or more different perceptions, alternately, while the sensation remains almost or quite unchanged.

PERCEPTION AND IMAGE

The experiment with ambiguous figures also gives an answer to the question whether perception consists in the addition of recalled memory images to the sensations aroused by the present stimulus. If that were so, you should, when you see the upper side of the flight of stairs, see them as wooden stairs or stone stairs, as carpeted or varnished, with shadows on them such as appear on a real flight of stairs, with a railing, or with some other addition of a similar nature; and, when the appearance changes to that of the under side of a flight of stairs, the colors, shadows, etc., should change as well. The usual report is that no such addition can be detected, and that the subject sees no filling-in of the picture, but simply the bare lines—only that they seem at one moment to be the bare outline of the upper side, and at another moment an equally bare outline of the lower side, of a flight of stairs.

So again, when you "hear the street car", you do not ordinarily, to judge from the reports of people who have been asked, get any visual or kinesthetic image of the car, but you simply know the car is there. You will quite pos-

¹ See p. 252.

sibly get some such image, if you *dwell* on the fact of the car's being there, just as some persons, in talking to a friend over the telephone, have a visual image of the friend. There is no reason why such images should not be aroused, but the question is whether they are essential to perception of the fact, and whether they occur before or after the fact is perceived. Often they do not occur, and often, when they do occur, they follow the perception of the fact, being aroused by that perception and not constituting it.

Sometimes images are certainly aroused during the perception of a fact, and, blending with the present rather vague sensation, add color and filling to the picture.

Here is an instance of this which I once observed in myself, in spite of the infrequency of my visual images. Approaching a house through a wide field one winter night, and seeing a lamp shining out of a window towards me, I seemed to see the yellowish light touching the high spots in the grass around. I was surprised that the lamp should carry so far, and the next instant saw that the light spots on the ground were small patches of snow, lighted only from the clouded sky; and at this the yellow tinge of the spots vanished. I must have read the yellow color into them to fit the lamplight. The yellow was an image blending with the actual sensation. Colors tacked on to a seen object in this way are sometimes called "memory colors".

When this instance is considered carefully, however, it does not by any means indicate that the image produced the perception. I responded to the pair of stimuli—lamp shining towards me and light spots around me—by perceiving the spots as lighted by the lamp; and the color followed suit. I next saw the spots as snow, and the color vanished. It was a case of trial and error perception, with color images conforming to the perception.

✓ Perception does not essentially consist in the recall of

images, but is a different sort of response—what sort, we have still to consider.

PERCEPTION AND MOTOR REACTION

Possibly, we may surmise, perception is a motor response, completely executed or perhaps merely incipient, or at least a readiness for a certain motor response. This guess is not quite so wild as our customary sharp distinction between knowing and doing might lead us to think. When we say that reacting to a thing in a motor way is quite different from merely seeing the thing, we forget how likely the child is to do something with any object as soon as he sees what it is. We forget also how common it is for a person, in silently reading a word—which is perceiving the word—to whisper it or at least move his lips. To be sure, persons who read a great deal usually get over this habit, as the child more and more inhibits his motor response to many seen objects. But may it not be that the motor response is simply reduced to a minimum? Or, still better, may it not be that perceiving an object amounts to *getting ready* to do something with it? May not seeing a word always be a getting ready to say it, even if no actual movement of the vocal organs occurs? May not seeing an orange consist in getting ready to take it, peel it, and eat it? May not perceiving our friend amount to the same thing as getting ready to behave in a friendly manner, and perceiving our enemy amount to the same thing as getting on our guard against him? According to this view, perception would be a response that adjusted the perceiver to the fact perceived, and made him ready to do something appropriate.

In spite of the attractiveness of this theory of perception, it is probably not the real essence of the matter. Just as perception may change while sensation remains the same, so there may be a hesitation between two motor responses

to an object, without any change in the way it is perceived; and just as a block may occur between sensation and perception, so also may one occur between perception of a fact and the motor response. In other words, perception of a fact may not spell complete readiness to act upon it. The best example of this is afforded again by cases of localized brain injuries.

It happens, in motor aphasia, that the subject hears and understands a spoken word—fully perceives it—and yet cannot pronounce it himself. And at that, there need be no paralysis of the speech organs. The brain injury has affected the motor speech-coördinating machinery, and deprived the individual of the power to get ready for speaking a word, even though he perceives it.

Analogous disabilities occur in respect to other movements. It may happen, through injury somewhere near the motor area, though not precisely in that area, that one who clearly perceives a seen object is still quite incapable of handling it. He knows the object, and he knows in an abstract way what to do with it, but how to go about it he cannot remember. This type of disturbance is called “motor apraxia”, and, like motor aphasia, it proves that there is a preparation that follows perception and still precedes actual movement. Paralysis of the motor area is different; then, the subject both perceives the object, and gets all ready to act upon it; only, the movement does not occur.

The truth seems to be that a series of four responses occurs in the brain, in the process of making a skilled movement dealing with a perceived object. First, sensation; second, perception of the object; third, coördinating preparation for the act; and fourth, execution of the act by the motor area arousing the lower motor centers and through them the muscles. The first response is like receiving signals

or code messages; the second deciphers the messages and knows the state of affairs; the third plans action; and the fourth sends out orders to the agents that perform the action.

The distinction between perception and preparation for action is sometimes rather difficult to draw. The twelve o'clock whistle means time to drop your tools, and it is hard to draw a line between knowing the fact and beginning the act. On the other hand, when my watch tells me the noon hour is almost over, some little time may be required before I get into motion. Where there is no block or inhibition, the chain of responses runs off with such speed as to seem a single response. But a block may occur at any one of several places. It may check the actual movement, as in the "delayed reaction",¹ and in cases where we itch to do something yet check ourselves. Here the preparation occurs, but the execution is checked. Sometimes the block occurs between perception and preparation, when we know a fact but find nothing to do about it or hesitate between two ways of acting. Sometimes, also, the block occurs between sensation and perception; a sudden loud noise will sometimes throw a person into a momentary state of confusion during which he is unable to recognize the noise.

Blocking of response at different stages can be illustrated very well in the case of anger. The irritating stimulus gives a prompt fighting reaction, unless checked at some stage. When the check prevents me from actually striking the offending person, but leaves me clenching my fist and gnashing my teeth, the chain of responses has evidently gone as far as readiness for action, and been blocked between that stage and the stage of execution. Probably the inhibitory influence here is anticipation of bad consequences. The block may occur one stage further back, when I say to myself that

¹ See p. 76.

I mustn't let myself get "all riled up" since it will spoil my morning's work; here, instead of substituting the clenched fist for actual fighting, I substitute a bored or contemptuous attitude for the pugnacious attitude. All this time I still am conscious of the offense done me. But suppose something leads me to try to look at the other person's behavior from his own point of view—then I perceive it in a different light, and it may no longer appear a personal offense to myself. I here get a substitute perception.

The process of blocking and substituting is the same process that we have seen in trial and error.¹ The response proving unsatisfactory, or promising to be unsatisfactory, is checked and a substitute response found. Other elements in the situation get a chance to exert their influence on the reaction. If perception of a fact were absolutely the same as preparing a motor act, we could not look over the situation, perceiving one fact after another, and letting our adjustment for action depend on the total situation instead of on the separate facts successively observed; nor could we perceive one fact while preparing the motor response to another fact, as is actually done in telegraphy, typewriting, reading aloud, and many other sorts of skilled action. In reading aloud, the eyes on the page keep well ahead of the voice; while one word is being pronounced, the next word is being prepared for pronouncing, and words still further ahead are in process of being perceived.

We conclude, accordingly, that perception of an object is not absolutely the same thing as motor response to the object, nor even as motor readiness to respond, although the transition from perception to motor readiness may be so quick that the whole reaction seems a unit. In reality, perception of the object precedes the motor adjustment, and is one factor in determining that adjustment.

¹ See p. 408.

WHAT SORT OF RESPONSE, THEN, IS PERCEPTION?

We can say this, that perception is knowing the fact, as distinguished from readiness to act. We can say that perception is an adjustment to facts as they are, while motor adjustment is a preparation for changing the facts. Perception does not alter the facts, but takes them as they are; movement alters the facts or produces new facts. We can say that perception comes in between sensation and motor preparation. But none of these statements is quite enough to satisfy us, if we wish to know something of the machinery of perception. What is the stimulus in perception, and what is the nature of the response?

It takes a collection of stimuli to arouse a perception. This collection is at the same time a selection from among the whole mass of sensory stimuli acting at any moment on the individual. Perception is thus a fine example both of the "law of selection" and of the "law of combination".¹ Perception is at once a *combining* response and an *isolating* response.

We perceive a face—that means that we take the face as a unit, or make a unitary response to the multiple stimuli coming from the face. At the same time, in perceiving the face, we isolate it from its background, or disregard the numerous other stimuli that are simultaneously acting upon us. If we proceed to examine the face in detail, we may isolate the nose and perceive that as a whole. We might isolate still further and perceive a freckle on the nose, taking that as a whole, or even observing separately its location, diameter, depth of pigmentation, etc. Even if we went so far as to observe a single speck of dust on the skin, in which case isolation would about reach its maximum, combination would still stay in the game, for we should either note

¹ See pp. 256, 263.

the location of the speck—which would involve relating it to some part of the face—or we should contrast it with the color of the skin, or in some similar way take the single stimulus in relation with other present stimuli. Perception is always a unitary response to an isolated assemblage of stimuli.

Consider these two opposite extremes: taking in the general effect of the view from a mountain top, and perceiving the prick of a pin. In the first case, combination is very much in evidence, but where is the isolation? There is isolation, since internal bodily sensations, and very likely auditory and olfactory sensations as well, are present but do not enter into the view. In the case of the pin prick, isolation is evident, but where does combination come in? It would not come into the mere reflex of pulling the hand away, but perceiving the pin means something more than reflex action. It means locating the sensation, or noticing its quality or duration or something of that sort, and so contrasting it with other sensations or relating it to them in some way. To perceive one stimulus as related to another is to respond to both together.

But in describing perception as a unitary response to an isolated assemblage of stimuli, we have not differentiated it from a motor response, for that, too, is often aroused by a few (or many) stimuli acting together. What more can we say? In neural terms, we can only repeat what was said before, that perception is the next response after sensation, being a direct response to a certain combination of sensations, and being in its turn the stimulus, or part of the stimulus, that arouses a motor adjustment, as it may also be the stimulus to recall of previously observed facts. In more psychological terms, we can say that sense perception is closely bound up with sensation, so that we seem to see the fact, or hear it, etc.; we perceive it as present to the

senses, rather than as thought of or as anticipated. Motor readiness is anticipatory, perception definitely objective. Motor readiness is an adjustment for something yet to be, while perception is an adjustment to something already present.

PRACTISED PERCEPTION

A fact perceived for the first time must needs be attended to, in order that it may be perceived. That is, the first and original perception of a fact is a highly conscious response. But the perception of a fact, like any other form of response, becomes easy with practice; the linkage of stimulus and response becomes stronger and stronger, till finally the stimulus arouses the perceptive response almost automatically. The familiar fact is perceived without receiving close attention, or even without receiving any attention. While your attention is absorbed in reading or thinking, you may respond to the sight of the flower in a vase on your table by knowing it to be there, you may respond to the noise of the passing street car by knowing what that is, and you may respond to the contact of your foot with the leg of the chair by dimly knowing what that object is. A great deal of this inattentive perception of familiar facts is always going on. Aside from sensation and from some of the reflexes, the perception of familiar facts is the most practised and the easiest of all responses.

The laws and sub-laws of learning apply perfectly to practised perception. The more frequently, the more recently, and the more intensely a given fact has been perceived, the more readily is it perceived again. The more a given fact is in line with the mental set of the moment, the more readily is it perceived. Sometimes it is so readily perceived that we think we see it when it isn't there. If you are hunting for a lost knife, anything remotely resembling

a knife will catch your eye and for an instant be perceived as the missing object.

The principle of *substitute stimulus* applies remarkably well to practised perception. The first time you perceive an object, you observe it attentively, and expose your perceptive apparatus to the whole collection of stimuli that the object sends your way. The next time you need not observe it so attentively, for you make the same perceptive response to a *part* of the original collection of stimuli. The response originally aroused by the whole collection of stimuli is later aroused by a fraction of this collection. The stimulus may be *reduced* considerably, and still arouse the perception of the same fact. A child is making the acquaintance of the dog. The dog barks, and the child watches the performance. He not only sees the dog, and hears the noise, but he *sees* the dog bark, and *hears* the dog bark. This original perception is a unitary response to the combination of sight and sound. Thereafter he does not require both stimuli at once, but, when he hears this noise, he perceives the dog barking, and when he sees the dog he sees an object that can bark. In the same way, a thousand objects which furnish stimuli to more than one of the senses are perceived as units, and, later, need only act on a single sense to be known.

The stimulus, instead of being reduced, may be *modified*, and still arouse the same perception as before. A face appears in the baby's field of view, but away across the room so that it is a very small object, visually. The face approaches and gradually becomes a larger visual object, and the light and shadow upon it change from moment to moment, but it remains nearly enough the same to arouse essentially the same perception in the child. He comes to know the face at various distances and angles and under various lights.

Again, the child holds a block in his hands, and looks at it square on, so that it is really a rectangle in his field of view. He turns it slightly, and now it is no longer visually a rectangle, but an oblique parallelogram. But the change is not enough to abolish the first perception; he sees it as the same object as before. By dint of many such experiences, we see a book cover or a door as a rectangle, no matter at what angle we may view it, and we know a circle for a circle even though at most angles it is really an ellipse in the field of view. A large share of practised perceptions belong under the head of "response by analogy",¹ since they consist in making the same response to the present stimulus that has previously been made to a similar but not identical stimulus. If every modified stimulus gave a new and different perception, it would be a slow job getting acquainted with the world. A thing is never twice the same, as a collection of stimuli, and yet, within wide limits, it is always perceived as the same thing.

CORRECTED PERCEPTION

Response by analogy, however, often leads us astray, in making us perceive a new object as essentially the same as something already familiar. First impressions of a new object or acquaintance often need revision, because they do not work well. They do not work well because they are rough and ready, taking the object in the lump, with scant attention to details which may prove to be important. It is easy to follow the law of combination and respond to a whole collection of stimuli, but to break up the collection and isolate out of it a smaller collection to respond to—that is something we will not do unless forced to it. Isolation and discrimination are uphill work. When they occur, it is be-

¹ See p. 406.

cause the rough and ready response has proved unsatisfactory.

Substitute response is the big factor in corrected perception, as substitute stimulus is in practised perception. When our first perception of an object gets us into difficulties, then we are forced to attend more closely and find something in the object that can serve as the stimulus to a better response. This is the process by which we isolate, analyze, discriminate.

Our old friend, the white rat, learned to enter a door only if it bore a yellow sign.¹ It was uphill work for him, hundreds of trials being required before the discriminating response was established; but he learned it finally. At the outset, a door was a door to the rat, and responded to as such, without regard to the sign. Whenever he entered a door without the sign, he got a shock, and scurried back; and before venturing again he looked all around, seeking, we may say, a stimulus to guide him; incidentally, he looked at the yellow disk, and this stimulus, though inconspicuous and feeble to a rat, finally got linked up with the entering response. The response of first finding and then following the sign had been substituted for the original response of simply entering.

In the same way the newly hatched chick, which at first pecks at all small objects, caterpillars included, learns to discriminate against caterpillars. In a practical sense, the chick, like the rat, learns to distinguish between stimuli that at first aroused the same response. It is in the same way that the human being is driven to discriminate and attend to details. He is brought to a halt by the poor results of his first rough and ready perception, scans the situation, isolates some detail and, finding response to this detail to bring satisfactory results, substitutes response to this de-

¹ See p. 304.

tail for his first indiscriminating response to the whole object.

The child at first treats gloves as alike, whether rights or lefts, but thus gets into trouble, and is driven to look at them more sharply till he perceives the special characteristics of rights and lefts. He could not describe the difference, to be sure, but he sees it well enough for his purposes. If you ask an older person to describe this difference, and rally him on his inability to do so, he is thus driven to lay them side by side and study out the difference still more precisely.

The average non-mechanical person, on acquiring an automobile, takes it as a gift of the gods, a big total thing, simply to sit in and go. He soon learns certain parts that he must deal with, but most of the works remain a mystery to him. Then something goes wrong, and he gets out to look. "What do you suppose this thing is here? I never noticed it before". Tire trouble teaches him about wheels, engine trouble leads him to know the engine, ignition trouble may lead him to notice certain wires and binding-posts that were too inconspicuous at first to attract his attention. A car becomes to him a thing with a hundred well-known parts, instead of just one big totality.

Blocked response, closer examination; new stimulus isolated that gives satisfactory response—such is, typically, the process of analytic perception.

SENSORY DATA SERVING AS SIGNS OF VARIOUS SORTS OF FACT

Among facts perceived, we may list things and events, and their qualities and relations. Under "things" we here include persons and animals and everything that would ordinarily be called an "object". Under "events", we include movement, change and happenings of all sorts. Under

“qualities” we may include everything that can be discovered in a thing or event taken by itself, and under “relations” anything that can be discovered by comparing or contrasting two things or events. The “groups” that we have several times spoken of as being observed would here be included under “things”; but the strict logic of the whole classification is not a matter of importance, as the only object in view is to call attention to the great variety of facts that are perceived.

Now the question arises, by what signs or indications these various facts are perceived. Often, as we have seen, the fact is by no means fully presented to the senses, and often it is far from easy for the perceiver to tell on what signs the perception depends. He knows the fact, but how he knows it he cannot tell. A large part of the very extensive experimental investigation of perception has been concerned with this problem of ferreting out the signs on which the various perceptions are based, the precise stimuli to which the perceptions respond.

For example, we can examine objects by feeling of them with a stick held in the hand, and thus perceive their roughness or smoothness; but how do we sense these facts? It seems to us as if we felt them with the end of the stick, but that is absurd, since there are no sense organs in the stick. It must be that we perceive the roughness by means of sensations arising in the hand and arm, but to identify these sensations is a much harder task than to discover the objective fact of roughness.

Again, we distinguish the tones of two musical instruments by aid of their overtones, but elaborate experiments were required to prove this, since ordinarily we do not distinguish the overtones, and could simply say that the instruments sounded differently, and let it go at that.

Once more, consider our ability to perceive time intervals,

and to distinguish an interval of a second from one of a second and a quarter. How in the world can any one perceive time? Time is no force that could conceivably act as a stimulus to a sense organ. It must be some change or process that is the stimulus and that serves as the indication of duration. Most likely, it is some muscular or internal bodily change, but none of the more precise suggestions that have been offered square with all the facts. It cannot be the movements of breathing that give us our perception of time, for we can hold our breath and still distinguish one short interval from another. It cannot be the heart beat, for we can beat time in a rhythm that cuts across the rate of the heart beat. When a singer is accompanying himself on the piano, keeping good time in spite of the fact that the notes are uneven in length, and meanwhile using his feet on the pedals, what has he got left to beat time with? No one has located the stimulus to which accurate time perception responds, though, in a general way, we are pretty sure that change of one sort or another is the datum. With longer intervals, from a minute to several hours, the sign of duration is probably the amount happening in the interval, or else such progressive bodily changes as hunger and fatigue.

THE PERCEPTION OF SPACE

Stimuli for the perception of location are provided by all the senses. We perceive a taste as in the mouth, thirst as in the throat, hunger pangs as in the stomach. To a familiar odor we may respond by knowing the odorous substance to be close at hand. To stimulation of the semi-circular canals we respond by knowing the direction in which we are being turned.

We respond to sounds by knowing the direction from which they come, and the distance from which they come;

but it must be confessed that we are liable to gross errors here. To perceive the distance of the sounding body we have to be familiar with the sound at various distances, and our perception of distance is based on this knowledge. As to the direction of sound, experiment has proved that we do little more than distinguish between right and left; we are all at sea in attempting to distinguish front from back or up from down. Apparently the only datum we have to go by is the different stimulation given the two ears according as the sound comes from the right or left.

The remaining senses, the cutaneous, the kinesthetic and the visual, afford much fuller data for the perception of spatial facts. Movements of the limbs are perceived quite accurately as to direction and extent.

A cutaneous stimulus is located with fair exactness, though much less exactly on such regions as the back than on the hands or lips. If you were asked how you distinguished one point from another on the back of the hand, you could only answer that they felt different; and if you were further asked whether a pencil point applied to the two points of the skin did not feel the same, you would have to acknowledge that it did feel the same, except that it was felt in a different place. In other words, you would not be able to identify the exact data on which your perception of cutaneous position is based. Science has done no better, but has simply given the name of "local sign" to the unanalyzed sensory datum that gives a knowledge of the point stimulated.

In handling an object, as also in walking and many other movements, the cutaneous and kinesthetic senses are stimulated together, and between them furnish data for the perception of many spatial facts, such as the shape of an object examined by the hand. The spherical shape is certainly better perceived by this combination of tactile and kinesthetic

sensations than by vision, and the same is probably true of many similar spatial facts. That is, when we see a round ball, the visual stimulus is a substitute for the tactile and cutaneous stimuli that originally had most to do with arousing this perception.

In part by this route of the substitute stimulus, the sense of vision comes to arouse almost all sorts of spatial perceptions. Of itself, the retina has "local sign", since we can tell where in the field of view a seen object is, i.e., in what direction it is from us. This visual perception of location is so much more exact than the cutaneous or kinaesthetic that it cannot possibly be derived from them; and the same is true of the visual perception of difference in length, which is one of the most accurate forms of perception. The retina must of itself afford very complete stimuli for the perception of location and size, as far as these are confined to the two dimensions, up-down and right-left. But, when you stop to think, it seems impossible that the retina should afford any data for perceiving distance in the front-back dimension.

The retina is a screen, and the stimulus that it gets from the world outside is like a picture cast upon a screen. The picture has the right-left and up-down dimensions, but no front-back dimension. How, then, does it come about, as it certainly does, that we perceive by aid of the eye the distance of objects from us, and the solidity and relief of objects? This problem in visual perception has received much attention and been carried to a satisfactory solution.

Consider, first, what stimuli indicative of distance and relief could affect a single motionless eye. The picture on the retina could then be duplicated by a painter on canvas, and the signs of distance available would be the same in the two cases. The painter uses foreshortening, making a man in the picture small in proportion to his distance away;

and in the same way, when any familiar object casts a small picture on the retina, we perceive the object, not as diminished in size, but as far away. The painter colors his near hills green, his distant ones blue, and washes out all detail in the latter—"aërial perspective", he calls this. His distant hill peeks from behind his nearer one, being partially covered by it. His shadows fall in a way to indicate the relief of the landscape. These signs of distance also affect the single resting eye and are responded to by appropriate spatial perceptions.

Now let the single eye move, with the head, from side to side: an index of the distance of objects is thus obtained, additional to all the painter has at his disposal, for the distant objects in the field of view now seem to move with the eye, while the nearer objects slide in the opposite direction. How much this sign is ordinarily made use of in perceiving distance is not known; it is believed not to be used very much, and yet it is the most delicate of all the signs of distance. The reason why it may not be much used by two-eyed people is that another index almost as delicate and handier to use is afforded by binocular vision.

When both eyes are open, we have a sign of distance that the painter does not use, though it is used in stereoscope slides. The right and left eyes get somewhat different views of the same solid object, the right eye seeing a little further around the object to the right, and the left eye to the left. The disparity between the two retinal images, due to the different angles at which they view the object, is greatest when the object is close at hand, and diminishes to practically zero when it is a few hundred feet away. This disparity between the two retinal images is responded to by perception of the distance and relief of the object.

It will be recalled¹ that when two utterly inconsistent

¹ See pp. 253-254.

views are presented to the two eyes, as a red field to one and a green field to the other, the visual apparatus balks and refuses to see more than one at a time—the binocular rivalry phenomenon. But when the disparate views are such as are presented to the two eyes by the same solid object, the visual apparatus (following the law of combination) responds to the double stimulation by getting a single view of an object in three dimensions.

ESTHETIC PERCEPTION

Beauty, humor, pathos and sublimity can be perceived by the senses, though we might debate a long time over the question whether these characteristics are really objective, or merely our own feelings aroused by the objects, and then projected into them. However that may be, there is no doubt that the ability to make these responses is something that can be trained, and that some people are blind and deaf to beauty and humor that other people clearly perceive. Many a one fails to see the point of a joke, or is unable to find any humor in the situation, which are clearly perceived by another. Many a one sees only a sign of rain in a great bank of clouds, only a weary climb in the looming mountain.

“A primrose by the river’s brim
A yellow primrose was to him,
And it was nothing more.”

It would not be quite fair to describe such a one as lacking in feeling; he probably has, on sufficient stimulus, the same feelings as another man, and it would be more exact to say that he is lacking in perception of certain qualities and relations. He probably tends, by nature and training, to practical rather than esthetic perception. To see any

beauty in a new style of music or painting, or to sense the humor in a new form of humorous writing, you need to be initiated, to be trained in observing the precise qualities and relations that are depended on for the esthetic effect. A complex situation presents almost an unlimited range of facts that may be perceived; no one perceives them all, and which he shall perceive depends on his nature and training, as well as on his attitude or mental set at the moment when the situation is presented.

Psychology has not by any means been idle in this field of esthetics; it has developed experimental methods for determining the preferences of individuals and of social groups. But it must be confessed that the results offer little that can be succinctly summarized.

One curious result is that even the very simplest objects can produce an esthetic effect. You would scarcely suppose, for example, that a mere rectangle could produce any esthetic effect, or that it would make any difference what exact proportions the rectangle possessed; and yet it is found that some rectangles are preferred to others, and that the popular choice falls upon what the art theorists have long known as the "golden section", a rectangle with a width about sixty-two per cent. of its length. Also, however much you may like symmetry, you would scarcely suppose that it could make much difference where, on a horizontal line, a little cross line should be erected; and yet nearly every one, on being tested, will agree that the middle is the best point. These are merely a couple of sample results from the numerous studies in this field.

SOCIAL PERCEPTION

By the senses we perceive the motives and intentions of other people, their sincerity, goodness, intelligence, and

many other traits. We see them angry or bored, amused, full of energy. To be sure, none of these human characteristics is directly and fully sensed, but that is the case also with many characteristics of inanimate objects which, nevertheless, we perceive by aid of the senses. We perceive anger or sincerity in much the same way that we perceive moisture or smoothness by the eye. To experience the anger of another person is a complex experience, but a single element from this experience may come to serve as the sign of the whole condition. A good share of the child's undirected education consists in learning to perceive the intentions and characteristics of other people by aid of little signs. He learns to read the signs of the weather in the family circle, and he learns in some measure to be a judge of men.

I once saw an instructive little incident, in which an older boy suddenly grabbed the cap from a little boy's head, and held it out to the driver of a passing automobile, as if giving it to him. The man saw the joke, and drove on laughing, but the little boy took it seriously and was quite worried for fear the man would carry off his cap. An older child would have "seen into" the situation readily; he could not have been teased in that way. Many social situations which are "all Greek" to a little child are understood readily by an older person.

It would be very valuable if psychology could succeed in analyzing out the signs by which such a trait as intelligence or "will power" is perceived, so as to reduce such perception to a science; but it is very doubtful if this can be done. Some persons who probably have themselves a keen perception of such traits have put forward systems, based upon the shape of the face, etc. They probably think they perceive human traits according to their systems, but the systems fail in other hands, and are undoubtedly falla-

cious. No good judge of character really goes by the shape of the face; he goes by little behavior signs which he has not analyzed out, and therefore cannot explain to another person.

You can tell very little regarding a person's intelligence from his photograph. This has now been pretty well established. Photographs of persons of various degrees of intelligence are placed before those who are reputed to be good judges, and their estimates compared with the test ratings, and there is no correspondence. You might just as well look at the back of the photograph as at the front.

Even with the person before you, you are likely to commit great errors. This sort of incident has happened. A young woman is brought before the court for delinquency, and the psychologist who has tested her testifies that she is of low intelligence. But the young woman is good-looking and graceful in her speech and manners, and so impresses the judge that he dismisses as "absurd" the notion of her being feeble-minded. He sets her free, on which she promptly gets into trouble again. Apparently the only way to perceive intelligence is to see a person in action, preferably under standard conditions, where his performance can be measured; that is to say, in an intelligence test.

ERRORS OF PERCEPTION

The grocer needs to be assured of the accuracy of his scales, and the chemist of the high accuracy of his chemical balance; the surveyor needs to know about the errors that may creep into the process of measuring the length of a line or angle. All of them, using instruments to assist in accurate perception of facts, are concerned about the accuracy of their instruments. Now, we all use the senses in perceiving facts, and "errors of sense" therefore concern us

all. Some of the errors committed in sense perception can be laid at the door of the senses, and some rather belong in the sphere of perception proper.

If you come out of a cold room into a warm room, the latter seems warmer than it is; and if you come out of a dark room into a light room, the latter seems brighter than it is. These errors, due to adaptation of the temperature sense and of the retina, are properly classed as errors of sense.

If you are taking a child's temperature with a "minute thermometer", it is best to use your watch to tell you when the minute is up, for the minute, when you are simply waiting for it to pass, seems very long. But if you are "working against time", a minute seems short. The professor is shocked when the closing bell rings, and thinks that certainly the hour cannot be up; but some of the students have been consulting their watches for quite a long while, being sure the hour must be nearly over. These are scarcely errors of sense, but they are errors of perception.

Where we tend to err in one certain direction from the truth, as in the examples just cited, psychology speaks of a "constant error", and evidently the knowledge of such constant errors is of importance wherever the facts are of importance. In a court of law, a witness often has to testify regarding the length of time occupied by some event, and a knowledge of the constant errors in time perception would therefore be of considerable legal importance. They would need to be worked out in considerable detail, since they differ according to the desires and attitude of the witness at the time of the event.

Besides constant errors, there are accidental or variable errors, due to slight momentary causes. Both constant and variable errors can be illustrated by a series of shots at a target. The variable error is illustrated by the scatter of

the hits, and the constant error by the excess of hits above the bull's-eye, or below, or to the right or left. The constant error can be corrected, once you know what it is; if results show that you tend to shoot too high, you can deliberately aim lower. But the variability of any performance

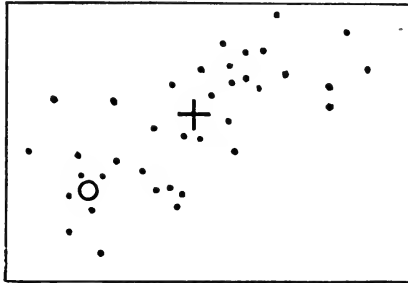

FIG. 66.—Constant error and scatter in hitting at a target. The little circle was the target, but the center of the actual distribution of the attempts lies at the cross, which was drawn in afterwards. The constant error could be stated by saying that the center of distribution was so far from the target, and in such and such a direction. The scattering of the attempts can be measured also.

cannot be eliminated except by long practice, and not altogether even then.

Experimental psychology has taken great pains in measuring the accuracy of different sorts of perception. How small a difference in length can be perceived by the eye, how small a difference of weight by the hand—these are sample problems in this line.

For example, to measure the fineness with which weights can be perceived when "hefted" in the hand, you take two objects that are alike in size and appearance but differing slightly in weight, and endeavor to decide which is the heavier just by lifting them. You try repeatedly and keep track of the number of errors, using this number as a measure of the accuracy of perception. Now, if one weight were twice as heavy as the other (one, for example, weighing 100 grams

and the other 200), you would never make an error except through carelessness; but if one were 100 and the other 120 grams, you would make an occasional error, and the number of errors would increase as the difference was decreased; finally, comparing 100 and 101 grams, you would get almost as many wrong as right, so that your perception of that small difference would be extremely unreliable.

ERRORS IN PERCEIVING SMALL DIFFERENCES
OF WEIGHT (From Warner Brown)

Difference	20	16	12	8	4	3	2	1	grams
Errors	1	2	5	13	28	31	39	44	per hundred trials

The weights were in the neighborhood of 100 grams; each weight was compared with the 100-gram weight, and each such pair was lifted and judged 1400 times. Notice that the per cent of errors gradually increases as the difference becomes smaller.

The smaller the difference between two stimuli, the more numerous the errors in perceiving it, or, the less perceptible it is, and there is no sharp line between a difference that can be perceived and one that is too small to be perceived. That is the first great result from the study of the perception of small differences.

The second great result is called *Weber's law*, which can be stated as follows: In the same sort of perception, equal relative (not absolute) differences are equally perceptible. For example, from the preceding table we see that 28 per cent. of errors are made in comparing weights of 100 and 104 grams; then, according to Weber's law, 28 per cent. of errors would also be made in comparing 200 grams with 208, or 500 with 520, or 1000 with 1040 grams, or any pair of weights that stood to each other in the ratio of 100 to 104. Weber's law is only approximately true for the perception of weights, since actually fewer errors are committed in comparing 500 and 520 than in comparing 100 and 104 grams; but the discrepancy is not extremely great here, and in

some other kinds of perception, as especially in comparing the brightness of lights or the length of seen lines, the law holds good over a wide range of stimuli and only breaks down near the upper and lower extremes. We are familiar, in ordinary life, with the general truth of Weber's law, since we know that an inch would make a much more perceptible addition to the length of a man's nose than to his height, and we know that turning on a second light when only one is already lit gives a much more noticeable increase in the light than if we add one more light when twenty are already burning.

A third great result of this line of study is that different sorts of perception are very unequal in their fineness and reliability. Perception of brightness is about the keenest, as under favorable conditions a difference of one part in one hundred can here be perceived with very few errors. Visual perception of length of line is good for about one part in fifty, perception of lifted weight for about one part in ten, perception of loudness of sound for about one part in three. But the perception of small differences in the pitch of musical tones is keener still, only that, not following Weber's law in the least, it cannot be expressed in the same way. A person with a good ear for pitch can distinguish with very few errors between two tones that differ by only one vibration per second, and can perceive this same *absolute* difference equally well, whether the total vibration rate is 200, 400, or 800 vibrations per second.

ILLUSIONS

An error of perception is often called an "illusion", though this term is commonly reserved for errors that are large and curious. When one who is being awakened by a bell perceives it as a tom-tom, that is an illusion. An illu-

sion consists in responding to a sensory stimulus by perceiving something that is not really there. The stimulus is there, but not the fact which it is taken to indicate. Illusion is false perception.

The study of illusions is of value, not only as showing how far a given kind of perception can be trusted, but also as throwing light on the process of perception. When a process goes wrong, it sometimes reveals its inner mechanism more clearly than when everything is running smoothly. Errors of any kind are meat to the psychologist.

Illusions may be classified under several headings according to the factors that are operative in causing the deception.

1. **Illusions due to peculiarities of the sense organs.** Here the stimulus is distorted by the sense organ and so may easily be taken as the sign of an unreal fact.

Separate the points of a pair of compasses by about three-quarters of an inch, and draw them across the mouth, one point above it and the other below; you will get the illusion of the points separating as they approach the middle of the mouth (where the sensory nerve supply is greatest), and coming together again as they are drawn to the cheek at the other side.

Under this same general head belong also after-images and contrast colors, and also double vision whenever for any reason the two eyes are not accurately converged upon an object. The fact that a vertical line appears longer than an equal horizontal is supposed to depend upon some peculiarity of the retina. Aside from the use of this class of illusions in the detailed study of the different senses, the chief thing to learn from them is they so seldom are full-fledged illusions, because they are ignored or allowed for, and not taken as the signs of facts. An after-image would constitute a genuine illusion if it were taken for some real

thing out there; but as a matter of fact, though after-images occur very frequently—slight ones practically every time the eyes are turned—they are ignored to such an extent that the student of psychology, when he reads about them, often thinks them to be something unusual and lying outside of his own experience. The same is true of double images. This all goes to show how strong is the tendency to disregard mere sensation in the interest of getting objective facts.

2. Illusions due to preoccupation or mental set.

When an insane person hears the creaking of a rocking-chair as the voice of some one calling him bad names, it is because he is preoccupied with suspicion. We might almost call this an hallucination,¹ since he is projecting his own auditory images and taking them for real sensations; it is, at any rate, an extreme instance of illusion. In a milder form, similar illusions are often momentarily present in a perfectly normal person, as when he is searching for a lost object and thinks he sees it whenever anything remotely similar to the desired object meets his eyes; or as when the mother, with the baby upstairs very much on her mind, imagines she hears him crying when the cat yowls or the next-door neighbors start their phonograph. The ghost-seeing and burglar-hearing illusions belong here as well. The mental set facilitates responses that are congruous with itself.

3. Illusions of the response-by-analogy type.

This is probably the commonest source of everyday illusions, and the same principle, as we have seen, is operative in a host of correct perceptions. Perceiving the obliquely presented rectangle as a rectangle is an example of correct perception of this type. Perceiving the buzzing of a fly as an aeroplane is the same sort of response only that it happens to be incorrect. If the present stimulus has something in com-

¹ See p. 375.

mon with the stimulus which has in the past aroused a certain perception, we may make the same response now as we did before—especially, of course, if the present mantel set favors this response.

A good instance of this type is the “proofreader’s illusion”, so called, perhaps, because the professional proofreader is less subject to it than any one else. The one most

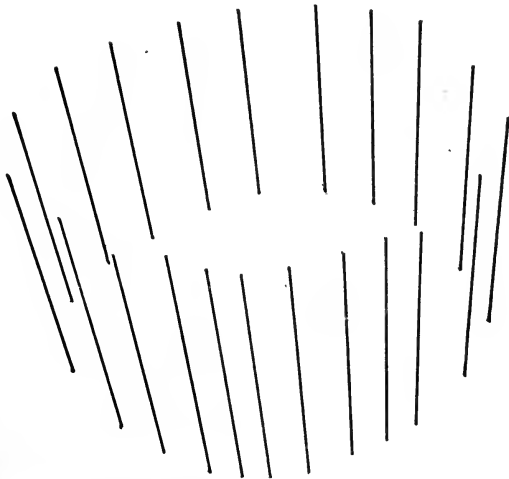

FIG. 67.—The Ladd-Franklin illusion of monocular perspective. Close one eye, and hold the book so that the other eye is at the common center from which the lines radiate; this center is about 5 inches from the figure. Hold the book horizontally, and just a little below the eye.

subject to it is the author of a book, for whom it is almost impossible to find every misspelled word and other typographical error in reading the proof. Almost every book comes out with a few such errors, in spite of having been scanned repeatedly by several people. A couple of misprints have purposely been left in the last few lines for the reader’s benefit. If the word as printed has enough resemblance to the right word, it arouses the same percept and enables the reader to get the sense and pass on satisfied.

Before we began to pore over books and pictures, the lines that we saw usually were the outlines of solid objects, and now it requires only a bare diagram of lines to arouse in us the perception of a solid object seen in perspective. An outline drawing, like those of the cube and staircase used to



FIG. 68.—Aristotle's illusion.

illustrate ambiguous perspective, is more readily seen as a solid object than as a flat figure.

Another illusion of this general type dates away back to Aristotle. Cross two fingers, perhaps best the second and third, and touch a marble with the crossed part of both fingers, and it seems to be two marbles; or, you can use the side of your pencil as the stimulus. In the customary position of the fingers, the stimuli thus received would mean two objects.

A much more modern illusion of the same general type is afforded by the moving pictures. The pictures do not actually show an object in motion; they simply show the object in a series of motionless positions, caught by instantaneous photography. The projector shows the series of snap-shots in rapid succession, and conceals them by a shutter while they are shifted, so as to avoid the blur that would occur if the picture were itself moved before the eyes. But the series of snap-shots has so much in common with the visual stimulus got from an actually present moving object that we make the same perceptive response.

The same illusion in a rudimentary form can be produced by holding the forefinger upright three or four inches in front of the nose, and looking at it while winking first the one eye and then the other. Looked at with the right eye alone it appears to be more to one side and looked at with the left eye alone it appears to be more to the other side; and when the one eye is closed and the other simultaneously opened, the finger seems actually to move from one position to the other.

4. Illusions due to imperfect isolation of the fact to be perceived. Here belong, probably, most of the illusions produced in the psychological laboratory by odd combina-

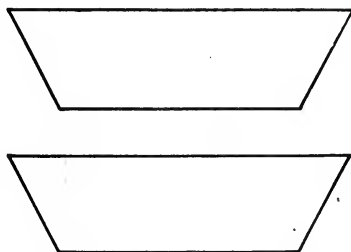

FIG. 69.—The pan illusion. The two pan-shaped outlines are practically identical, but it is hard to compare the corresponding sides—hard to isolate from the total figure just the elements that you need to compare.

tions of lines, etc. A figure is so drawn as to make it difficult to isolate the fact to be observed, and when the observer attempts to perceive it, he falls into error. He thinks he is perceiving one fact, when he is perceiving another. The best example is the Müller-Lyer figure, in which two equal lines are embellished with extra lines at their ends; you are supposed to perceive the lengths of the two main lines, but you are very apt to take the whole figure in the rough and perceive the distances between its chief parts. You do not succeed in isolating the precise fact you wish to observe.

The Müller-Lyer Illusion

The most familiar form of this striking illusion is made with arrow heads, thus



In attempting to compare the two horizontal lines one is confused so as to regard the line with outward-extending obliques longer than that with inward-extending obliques, though, measured from point to point, they are equal. The same illusion occurs in a variety of similar figures, such as $> < >$ where the main lines are not drawn, but the distances from point to point are to be compared; or such as $\blacktriangle \blacktriangleleft \blacktriangleright$ where the two distances between points are again to be compared. Angles, however, are not necessary to give the illusion, as can be seen in this figure $\supset \subset \supset$, or in this $\bigcirc \bigcirc \bigcirc$. In the last the lengths to be compared extend (a) from the right-hand rim of circle 1 to the left-hand rim of circle 2, and (b) from this last to the right-hand rim of circle 3. The same illusion can be got with squares, or even with capital letters as E E E or R R R or L L L where the distances between the main vertical lines are to be compared.

Here is another form of the same illusion

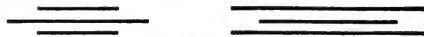

the middle lines being affected by those above and below.

Though these illusions seem like curiosities, and far from every-day experience, they really do enter in some degree into almost every figure that is not perfectly square and simple. Any oblique line, any complication of any sort, is

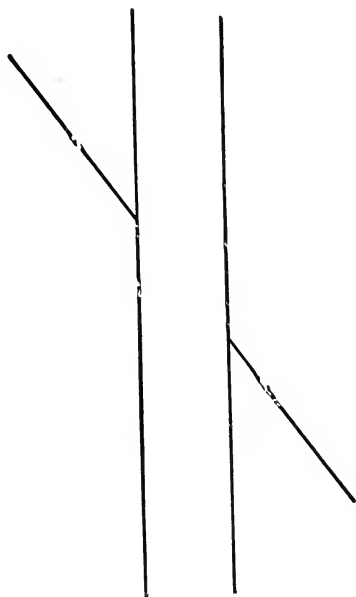

FIG. 70.—The Poggendorf illusion. Are the two obliques parts of the same straight line?

pretty sure to alter the apparent proportions and directions of the figure. A broad effect, a long effect, a skewed effect, may easily be produced by extra lines suitably introduced into a dress, into the front of a building, or into a design of any sort; so that the designer needs to have a practical knowledge of this type of illusion.

Extra lines have an influence also upon esthetic perception. The esthetic effect of a given form may be quite altered by the introduction of apparently insignificant extra

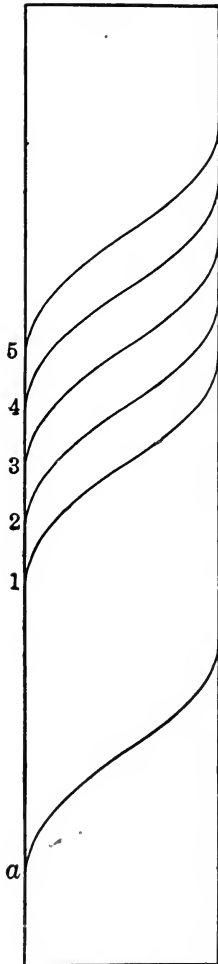

FIG. 71.—The barber-pole illusion. The rectangle represents a round column, around which runs a spiral, starting at *a*. Which of the lines, 1, 2, 3, 4, and 5, comes closest to being a continuation of *a*?

lines. Esthetic perception is very much subject to the law of combination, and to the resulting difficulty of isolation.

One of the most interesting illusions, not being visual, can

only be described and not demonstrated here. It is called the "size-weight illusion", and may be said to be based on



FIG. 72.—By aid of this simple figure, the Poggendorf and barber-pole illusions can be seen to be instances of the Müller-Lyer illusion. Try to bisect the horizontal line in this figure. The oblique line at the right tends to displace the right-hand end of the horizontal to the right, while the oblique at the left tends to displace the left-hand end of the horizontal also to the right. Similar displacements account for the Poggendorf and barber-pole illusions.

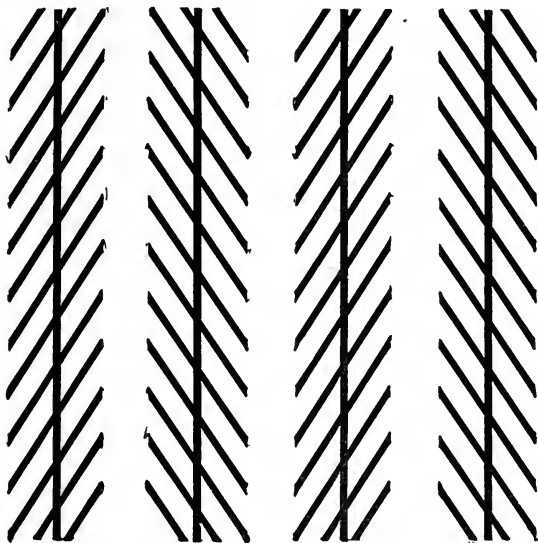

FIG. 73.—The Zoellner illusion. The long lines are really parallel. The illusion is increased by holding the figure so that these main lines shall be neither vertical nor horizontal. It is more difficult to "deceive the eye" in regard to the direction of vertical and horizontal lines, than in regard to the direction of oblique lines. This illusion must be related in some way to the Müller-Lyer and Poggendorf illusions, since the elements employed in constructing the three figures are so much the same.

If you treat this figure according to the directions given for Fig. 67, and sight along the obliques, you get an illusion of perspective.

the old catch, "Which is heavier, a pound of lead or a pound of feathers?" Of course, we shrewdly answer, a pound's

a pound. But lift them and notice how they feel! The pound of lead feels very much heavier. To reduce this illusion to a laboratory experiment, you take two round wooden pill-boxes, one several times as large as the other, and load them so that they both weigh the same; then ask some one to lift them and tell which is the heavier. He will have no doubt at all that the smaller box is the heavier; it may seem two or three times as heavy. Young children, however, get the opposite illusion, assimilating the weight to the visual appearance; but older persons switch over to the contrast effect, and perceive in opposition to the visual appearance. What seems to happen in the older person is a motor adjustment for the apparent weights, as indicated by their visual appearance, with the result that the weight of larger size is lifted more strongly than the weight of smaller size; so that the big one comes up easily and seems light, the little one slowly and seems heavy.

EXERCISES

1. Outline the chapter.
2. Show that the law of combination accounts both for many correct perceptions, and for many illusions.
3. Through which of the senses are spatial facts best perceived?
4. "At first, the baby very likely perceives a ball simply as something for him to handle and throw; but, through the medium of blocked response, he comes to perceive it more objectively, i.e., as an object related to other objects, and not simply related to himself." Explain and illustrate this statement.
5. Give an example from the field of auditory perceptions where "isolation" is very much in evidence.
6. Can you see any law analogous to Weber's law in the field of financial profit and loss? Does a dollar gained or lost *seem* the same amount, without regard to the total amount possessed?
7. Trial and error perception. Go about the room with closed eyes, and identify objects by touching them with the hands. Notice whether your first impression gives place to corrected impressions.
8. Perception of form by "active" and "passive" touch. With the eyes closed, try to distinguish objects of different shapes (a) by letting them simply rest upon the skin, and (b) by handling them. What senses coöperate in furnishing data for "active touch"?
9. Binocular parallax, or the differing views of the same solid object obtained by the two eyes. Hold a small, three-dimensional object a foot in front of the face, and notice carefully the view of it obtained by each eye separately. A pencil, pointing towards the face, gives very different views. What becomes of the two monocular views when both eyes are open at once?
10. Binocular compared with monocular perception of "depth" or distance away. Take a pencil in each hand, and bring the points together a foot in front of the face, while only one eye is open. When the points seem to be nearly touching, open the other eye, and see whether the two points still seem to be close together. Repeat.

REFERENCES

Discussions of perception that are in some respects fuller than the present chapter can be found in C. H. Judd's *Psychology, General Introduction*, 2nd edition, 1917, pp. 162-194; in Titchener's *Textbook of Psychology*, 1909, pp. 303-373; and in Warren's *Human Psychology*, 1919, pp. 232-269.

CHAPTER XVIII

REASONING

THE PROCESS OF MENTAL, AS DISTINGUISHED FROM MOTOR EXPLORATION

We are still on the general topic of "discovery". Indeed, we are still on the topic of perception; we come now to that form of perception which is different from sense perception. The reasoner is an explorer, and the culmination of his explorations is the perception of some fact previously unknown to him.

Reasoning might be described as mental exploration, and distinguished from purely motor exploration of the trial and error variety. Suppose you need the hammer, and go to the place where it is kept, only to find it gone. Now if you simply proceed to look here and there, ransacking the house without any plan, that would be motor exploration. But if, finding this trial and error procedure to be laborious and almost hopeless, you sit down and think, "Where can that hammer be? Probably where I used it last!" you may recall using it for a certain purpose, in a certain place, go there and find it. You have substituted mental exploration of the situation for purely motor exploration, and saved time and effort. Such instances show the use of reasoning, and the part it plays in behavior.

The *process* of reasoning is also illustrated very well in these simple cases. It is an exploratory process, a searching for facts. In a way, it is a trial and error process. If you don't ransack the house, at least you ransack your memory, in search for facts that will assist you. You recall this fact

and that, you turn this way and that, mentally, till some fact is recalled that serves your need. No more in reasoning than in motor exploration can you hope to go straight to the desired goal.

ANIMAL AND HUMAN EXPLORATION

Is man the only reasoning animal? The experimental work on animal learning, reviewed in one of our earlier chapters, was begun with this question in mind. Previous evidence on this point had been limited to anecdotes, such as that of the dog that was found opening a gate by lifting the latch with his nose, and was supposed to have seen men open the gate in this way, and to have *reasoned* that if a man could do that, why not a dog? The objection to this sort of evidence is that the dog's manner of acquiring the trick was not observed. Perhaps he reasoned it out, and perhaps he got it by accident—you cannot tell without watching the process of learning. You must experiment, by taking a dog that does not know the trick, and perhaps first "showing him" how to open the gate by lifting the latch; but it was found that dogs and cats, and even monkeys, could not learn the trick in this way. If, however, you placed a dog in a cage, the door of which could be opened by lifting a latch, and motivated the dog strongly by having him hungry and placing food just outside, then the dog went to work by trial and error, and lifted the latch in the course of his varied reactions; and if he were placed back in the cage time after time, his unsuccessful reactions were gradually eliminated and the successful reaction was firmly attached to the situation of being in that cage, so that he would finally lift the latch without any hesitation.

The behavior of the animal does not look like reasoning. For one thing, it is too impulsive and motor. The typical

attitudes of the reasoner, whether "lost in thought" or "studying over things", do not appear in the dog, or even in the monkey, though traces of them may perhaps be seen in the chimpanzee and other manlike apes. Further, the animal's learning curve fails to show sudden improvements such as in human learning curves follow "seeing into" the problem. In short, there is nothing to indicate that the animal recalls facts previously observed or sees their bearing on the problem in hand. He works by motor exploration, instead of mental. He does not search for "considerations" that may furnish a clue.

The behavior of human beings, placed figuratively in a cage, sometimes differs very little from that of an animal. Certainly it shows plenty of trial and error and random motor exploration; and often the puzzle is so blind that nothing but motor exploration will bring the solution. What the human behavior does show that is mostly absent from the animal is (1) attentive studying over the problem, scrutinizing it on various sides, in the effort to find a clue; (2) thinking, typically with closed eyes or abstracted gaze, in the effort to recall something that may bear on the problem; and (3) sudden "insights", when the present problem is seen in the light of past experience.

Though reason differs from animal trial and error in these respects, it still is a tentative, try-and-try-again process. The right clue is not necessarily hit upon at the first try; usually the reasoner finds one clue after another, and follows each one up by recall, only to get nowhere, till finally he notices a sign that recalls a pertinent meaning. His exploration of the situation, though carried on by aid of recalled experience instead of by locomotion, still resembles finding the way out of a maze with many blind alleys. In short, reasoning may be called a trial and error process in the sphere of mental reactions.

The reader familiar with geometry, which is distinctly a reasoning science, can readily verify this description. It is true that the demonstrations are set down in the book in a thoroughly orderly manner, proceeding straight from the given assumption to the final conclusion; but such a demonstration is only a dried specimen and does not by any means picture the living mental process of reasoning out a proposition. Solving an "original" is far from a straightforward process. You begin with a situation (what is "given") involving a problem (what is to be proved), and, studying over this lay-out you notice a certain fact which looks like a clue; this recalls some previous proposition which gives the significance of the clue, but often turns out to have no bearing on the problem, so that you shift to another clue; and so on, by what is certainly a trial and error process, till some fact noted in the situation plus some knowledge recalled by this fact, taken together, reveal the truth of the proposition.

REASONING CULMINATES IN INFERENCE

When you have described reasoning as a process of mental exploration, you have told only half the story. The successful reasoner not only seeks, but finds. He not only ransacks his memory for data bearing on his problem, but he finally "sees" the solution clearly. The whole exploratory process culminates in a perceptive reaction. What he "sees" is not presented to his senses at the moment, but he "sees that something *must* be so". This kind of perception may be called *inference*.

To bring out distinctly the perceptive reaction in reasoning, let us cite a few very simple cases. Two freshmen in college, getting acquainted, ask about each other's fathers and find that both are alumni of this same college. "What class was your father in?" "In the class of 1900. And

yours?" "Why, he was in 1900, too. Our fathers were in the same class; they must know each other!" Here two facts, one contributed by one person and the other by another person, enable both to perceive a third fact which neither of them knew before. Inference, typically, is a response to two facts, and the response consists in perceiving a third fact that is bound up in the other two.

You do not infer what you can perceive directly by the senses. If Mary and Kate are standing side by side, you can *see* which is the taller. But if they are not side by side, but Mary's height is given as so much and Kate's as an inch more, then from these two facts you know, by inference, that Kate is taller than Mary.

"Have we set the table for the right number of people?" "Well, we can see when the party comes to the table." "Oh! but we can tell now by counting. How many are there to be seated? One, two, three—fifteen in all. Now count the places at table—only fourteen. You will have to make room for one more." This reducing of the problem to numbers and then seeing how the numbers compare is one very simple and useful kind of inference.

Indirect comparison may be accomplished by other similar devices. I can reach around this tree trunk, but not around that, and thus I perceive that the second tree is thicker than the first, even though it may not look so. If two things are each found to be equal to a third thing, then I see they must be equal to each other; if one is larger than my yardstick and the other smaller, then I see they must be unequal.

Of the two facts which, taken together, yield an inferred fact, one is often a general rule or principle, and the inference then consists in seeing how the general rule applies to a special case. A dealer offers you a fine-looking diamond ring for five dollars, but you recall the rule that "all genuine diamonds are expensive", and perceive that this

diamond must be an imitation. This also is an instance of indirect comparison, the yardstick being the sum of five dollars; this ring measures five dollars, but any genuine diamond measures more than five dollars, and therefore a discrepancy is visible between this diamond and a genuine diamond. You can't see the discrepancy by the eye, but you see it by way of indirect comparison, just as you discover the difference between the heights of Mary and Kate by aid of the yardstick.

If all French writers are clear, then Binet, a French writer, must be clear. Here "French writers" furnish your yardstick. Perhaps it would suit this case a little better if, instead of speaking of indirect comparison by aid of a mental yardstick, we spoke in terms of "relations". When you have before your mind the relation of A to M, and also the relation of B to M, you may be able to see, or infer, a relation between A and B. M is the common point of reference to which A and B are related. Binet stands in a certain relation to "French writers", who furnish the point of reference; that is, he is one of them. Clear writing stands in a certain relation to French writers, being one of their qualities; from which combination of relations we perceive clear writing as a quality of Binet.

Just as an illusion is a false sense perception, so a false inference is called a "fallacy". One great cause of fallacies consists in the confused way in which facts are sometimes presented, resulting in failure to see the relationships clearly. If you read that

" Smith is taller than Brown; and
Jones is shorter than Smith; and therefore
Jones is shorter than Brown,"

the mix-up of "taller" and "shorter" makes it difficult to get the relationships clearly before you, and you are likely

to make a mistake. Or again, if Mary and Jane both resemble Winifred, can you infer that they resemble each other? You are likely to think so at first, till you notice that resemblance is not a precise enough relation to serve for purposes of indirect comparison. Mary may resemble Winifred in one respect, and Jane may resemble her in another respect, and there may be no resemblance between Mary and Jane.

Or, again,

“ All French writers are clear; but
James was not a French writer; and therefore
James was not a clear writer,”

may cause some confusion from failure to notice that the relation between French writers and clear writing is not reversible so that we could turn about and assert that all clear writers were French.

The reasoner needs a clear head and a steady mental eye; he needs to look squarely and steadily at his two given statements in order to perceive their exact relationship. Diagrams and symbols often assist in keeping the essential facts clear of extraneous matter, and so facilitate the right response.

To sum up: the process of reasoning culminates in two facts being present as stimuli, and the response, called “inference”, consists in perceiving a third fact that is implicated in the two stimulus-facts. It is a good case of the law of combination, and at the same time it is a case where “isolation” is needed, otherwise the response will be partly aroused by irrelevant stimuli, and thus be liable to error.

VARIETIES OF REASONING

Reasoning as a whole is a process of mental exploration culminating in inference. Now, without regard to possible

variations of the perceptive response of inference, there are at least different varieties of the exploratory process leading up to inference. The situation that arouses reasoning differs from one case to another, the motive for engaging in this rather laborious mental process differs, and the order of events in the process differs. There are several main types of reasoning, considered as a process of mental exploration.

1. Reasoning out the solution of a practical problem.

A "problem" is a situation for which we have no ready and successful response. We cannot successfully respond by instinct or by previously acquired habit. We must *find out* what to do. We explore the situation, partly by the senses and actual movement, partly by the use of our wits. We observe facts in the situation that recall previous experiences or previously learned rules and principles, and apply these to the present case. Many of these clues we reject at once as of no use; others we may try out and find useless; some we may think through and thus find useless; but finally, if our exploration is successful, we observe a real clue, recall a pertinent guiding principle, and see the way out of our problem.

Two boys went into the woods for a day's outing. They climbed about all the morning, and ate their lunch in a little clearing by the side of a brook. Then they started for home, striking straight through the woods, as they thought, in the direction of home. After quite a long tramp, when they thought they should be about out of the woods, they saw clear space ahead, and, pushing forward eagerly, found themselves in the same little clearing where they had eaten their lunch! Reasoning process No. 1 now occurred: one of the boys *recalled* that when traversing the woods without any compass or landmark, the traveller is very likely to go in a circle; inference, "That is what we have done and

we probably shall do the same thing again if we go ahead. We may as well sit down and think it over."

Mental exploration ensued. "How about following the brook?" "That won't do, for it flows down into a big swamp that we couldn't get through". "How about telling directions by the sun?" "But it has so clouded over that you can't tell east from west, or north from south." "Yes, those old clouds! How fast they are going! They seem to go straight enough." "Well, say! How about following the clouds? If we keep on going straight, in any direction, for a couple of hours, we shall surely get out of the woods somewhere." This seems worth trying and actually brings the boys out to a road where they can inquire the way home.

What we find in this case is typical of problem solution. First, a desire is aroused, and it facilitates the observation and recall of facts relevant to itself. One pertinent fact is observed, another pertinent fact, or rule, is recalled; and in these two taken together the key to the problem is found.

2. **Rationalization or self-justification.** While in the preceding case reasoning showed what to do, here it is called upon to justify what has been done, or what is going to be done anyway. The question is, what reason to assign for the act; we feel the need of meeting criticism, either from other people or from ourselves. The real motive for the act may be unknown to ourselves, as it often is unless we have made a careful study of motives; or, if known, it may not be such as we care to confess. We require a *reasonable* motive, some acceptable general principle that explains our action.

A child is unaccountably polite and helpful to his mother some day, and when asked about it replies that he simply wants to help—while his real motive may have been to score against his brother or sister, who is to some extent his rival.

If I have work requiring attention but want to go to the game, I should certainly be lacking in reasoning ability if I could not find something in the situation that made my attendance at the game imperative. I am stale, and the game will freshen me up and make me work better afterward. Or, I am in serious danger of degenerating into a mere "grind", and must fight against this evil tendency. Or, my presence at the game is necessary in order to encourage the team.

Thus, aspects of the situation that are in line with our desire bob to the surface and suggest acceptable general principles that make the intended action seem good and even necessary. Finding excuses for acts already performed is a reasoning exercise of the same sort. Man is a rationalizing animal as well as a rational animal, and his self-justifications and excuses, ludicrous though they often are, are still a tribute to his very laudable appreciation of rationality.

3. **Explanation.** This form of reasoning, like the preceding, takes its start with something that raises the question, "Why?" Only, our interest in the question is objective rather than subjective. It is not our own actions that call for explanation, but some fact of nature or of human behavior. Why—with apologies to the Southern Hemisphere!—is it so cold in January? The fact arouses our curiosity. We search the situation for clues, and recall past information, just as in the attempt to solve a practical problem. "Is it because there is so much snow in January?" "But what, then, makes it snow? This clue leads us in a circle." "Perhaps, then, it is because the sun shines so little of the time, and never gets high in the sky, even at noon." That is a pretty good clue; it recalls the general principle that, without a continued supply of heat, cold is inevitable. To explain a phenomenon is to deduce it from

an accepted general principle; to understand it is to see it as an instance of the general principle. Such understanding is very satisfactory, since it rids you of uncertainty and sometimes from fear, and gives you a sense of power and mastery.

4. **Application.** The reasoning processes discussed up to this point have taken their start with the particular, and have been concerned in a search for the general principle that holds good of the given particular case. Reasoning may also take its start at the other end, in a general statement, and seek for particular cases belonging under this general rule. But what can be the motive for this sort of reasoning? What is there about a general proposition to stimulate exploration?

Several motives may be in play. First, there may be a need for application of the general principle. Somebody whose authority you fully accept enunciates a general proposition, and you wish to apply it to special cases, either for seeing what practical use you can make of it, or simply to make its meaning more real and concrete to yourself. Your exploration here takes a different form from that thus far described. Instead of searching a concrete situation for clues, and your memory for general principles, you search your memory for particular cases where the general law should apply. If all animals are cold-blooded, excepting only birds and mammals, then fish and frogs and lizards are cold-blooded, spiders, insects, lobsters and worms; having drawn these inferences, your understanding of the general proposition becomes more complete.

5. **Doubt.** A general proposition may stimulate reasoning because you doubt it, and wish to find cases where it breaks down. Perhaps somebody makes the general statement whose authority you do not accept; perhaps he says it in an assertive way that makes you want to take him down

a peg. Perhaps you are in the heat of an argument with him, so that every assertion he may make is a challenge. You search your memory for instances belonging under the doubted general statement, in the hope of finding one where the general statement leads to a result that is contrary to fact. "You say that all politicians are grafters. Theodore Roosevelt was a politician, therefore, according to you, he must have been a grafter. But he was not a grafter, and you will have to take back that sweeping assertion."

6. **Verification.** This same general type of reasoning, which takes its start with a general proposition, and explores particular instances in order to see whether the proposition, when applied to them, gives a result in accordance with the facts, has much more serious uses; for this is the method by which a *hypothesis* is tested in science. A hypothesis is a general proposition put forward as a guess, subject to verification. If it is thoroughly verified, it will be accepted as a true statement, a "law of nature", but at the outset it is only a guess that may turn out to be either true or false. How shall its truth or falsity be demonstrated? By deducing its consequences, and testing these out in the realm of observed fact.

An example from the history of science is afforded by Harvey's discovery of the circulation of the blood, which was at first only a hypothesis, and a much-doubted one at that. If the blood is driven by the heart through the arteries, and returns to the heart by way of the veins, then the flow of blood in any particular artery must be away from the heart, and in any particular vein towards the heart. This deduction was readily verified. Further, there should be little tubes leading from the smallest arteries over into the smallest veins, and this discovery also was later verified, when the invention of the microscope made observation of the capillaries possible. Other deductions also were verified,

and in short all deductions from the hypothesis were verified, and the circulation of the blood became an accepted law.

Most hypotheses are not so fortunate as this one; most of them die by the wayside, since it is much easier to make a guess that shall fit the few facts we already know than to make one that will apply perfectly to many other facts at present unknown. A hypothesis is a great stimulus to the discovery of fresh facts. Science does not like to have unverified hypotheses lying around loose, where they may trip up the unwary. It is incumbent on any one who puts forward a hypothesis to apply it to as many special cases as possible, in order to see whether it works or not; and if the propounder of the hypothesis is so much in love with it that he fails to give it a thorough test, his scientific colleagues are sure to come to the rescue, for they, on the whole, would be rather pleased to see the other fellow's hypothesis come to grief. In this way, the rivalry motive plays a useful part in the progress and stabilizing of science.

DEDUCTIVE AND INDUCTIVE REASONING

When you are sure at the outset of your general proposition, and need only to see its application to special cases, your reasoning is said to be "deductive". Such reasoning is specially used in mathematics. But in natural science you are said to employ "inductive reasoning". The process has already been described. You start with particular facts demanding explanation or generalization, and try to find some accepted law that explains them. Failing in that, you are driven to guess at a general law, i.e., to formulate a hypothesis that will fit the known facts. Then, having found such a conjectural general law, you proceed to deduce its consequences; you see that, *if* the hypothesis is true, such and such facts must be true. Next you go out and see whether these facts are true, and if they are, your hypothesis

is verified to that extent, though it may be upset later. If the deduced facts are not true, the hypothesis is false, and you have to begin all over again.

The would-be natural scientist may fail at any one of several points. First, he may see no question that calls for investigation. Everything seems a matter-of-course, and he concludes that science is complete, with nothing left for him to discover. Second, seeing something that still requires explanation, he may lack fertility in guessing, or may be a poor guesser and set off on a wild-goose chase. Helmholtz, an extremely fertile inventor of high-grade hypotheses, describes how he went about it. He would load up in the morning with all the knowledge he could assemble on the given question, and go out in the afternoon for a leisurely ramble; when, without any strenuous effort on his part, the various facts would get together in new combinations and suggest explanations that neither he nor any one else had ever thought of before. Third, our would-be scientific investigator may lack the clear, steady vision to see the consequences of his hypothesis; and, fourth, he may lack the enterprise to go out and look for the facts that his hypothesis tells him should be found.

PSYCHOLOGY AND LOGIC

Psychology is not the only science that studies reasoning; that is the subject-matter of logic as well, and logic was in the field long before psychology. Psychology studies the *process* of reasoning, while logic checks up the result and shows whether it is valid or not. Logic cares nothing about the exploratory process that culminates in inference, but limits itself to inference alone.

Inference, in logical terminology, consists in drawing a conclusion from two given premises. The two premises are the "two facts" which, acting together, arouse the percep-

tive response called inference, and the "third fact" thus perceived is the conclusion.¹ Logic cares nothing as to how the premises were found, nor as to the motive that led to the search for them, nor as to the time and effort required, nor the difficulty encountered; these matters all pertain to psychology.

Logic sets forth the premises and conclusion in the form of the "syllogism", as in the old stand-by:

Major premise: All men are mortal
 Minor premise: Socrates is a man
 Conclusion: Therefore, Socrates is mortal

The syllogism includes three "terms", which in the above instance are "Socrates", "mortal", and "man" or "men". Logic employs the letters, S, P, and M to symbolize these three terms in general. S is the "subject" (or, we might say, the "object" or the "situation") about which something is inferred. P is the "predicate", or what is inferred about S; and M is the "middle term" which corresponds to our "yardstick" or "point of reference", as we used those words at the beginning of the chapter. S is compared with P through the medium of M; or, S and P are both known to be related to M, and therefore (when the relations are of the right sort) they are related to each other. It is part of the business of logic to examine what relations are, and what are not, suitable for yielding a valid inference.

In symbols, then, the syllogism becomes:

Major premise: M is P
 Minor premise: S is M
 Conclusion: Therefore, S is P

¹The "two facts" or premises need not be true; either or both may be assumed or hypothetical, and still they may lead to a valid conclusion, i.e., a conclusion implicated in the assumed premises.

Without confounding logic and psychology in the least, we may take this symbolic syllogism as a sort of map, on which to trace out the different exploratory processes that we have already described under the head of "varieties of reasoning". To do so may make these different processes stand out more distinctly.

In problem-solution, we start with S, a situation unsolved, i.e., without any P. P, when found, will be the solution. We explore the situation, and find in it M; i.e., we observe that S is M. Now M recalls our previously acquired knowledge that M is P. Having then before us the two premises, we perceive that S is P, and are saved.

In rationalization or explanation, we know, to start with, that S is P, and wish to know *why* this is so. As before, we explore S, find M, recall that M is P, and see that S, therefore, is P. Our final conclusion is, really, that S is P because it is M; that January is cold because it gets little sunlight.

In application, doubt or verification, we start with the major premise, M is P, and explore our memories for an S which, being M, should therefore be P according to our hypothesis. If we find an S which is *not* P, then our final conclusion is that the major premise is false.

Reference to our "map" indicates that there might be several other varieties of reasoning, and there are, indeed, though they are scarcely as important as those already mentioned. Reasoning sometimes starts with the observation of P, which means something that might prove useful on some future occasion. Your attention is caught by these prominent words in an advertisement, "\$100 a week!" That might come in handy on some future occasion, and you look further to see how all that money can be attached to S, yourself on some future occasion. You soon learn that you have only to secure subscriptions for a certain magazine,

and that income may be yours. P is the money, and M is the occupation that gives the money, while S is yourself supposedly entering on this occupation and earning the money. This type of reasoning is really quite common. If we see a person making a great success of anything, we try to discover how he does it, reasoning that if we do the same, we shall also be successful; or, if we see some one come to grief, we try to see how it happened, so as to avoid his mistake and so the bad consequences of that mistake. We plan to perform M so as to secure P, or to avoid M in the hope of avoiding P.

Sometimes, not so rarely, we have both premises handed out to us and have only to draw the conclusion. More often, we hear a person drawing a conclusion from only one expressed premise, and try to make out what the missing premise can be. Sometimes this is easy, as when one says, "I like him because he is always cheerful", from which you see that the person speaking must like cheerful persons. But if you hear it said that such a one "cannot be a real thinker, he is so positive in his opinions", or that another "is unfeeling and unsympathetic from lack of a touch of cruelty in his nature", you may have to explore about considerably before finding acceptable major premises from which such conclusions can be deduced.

Finally, in asking what are the *qualifications of a good reasoner*, we can help ourselves once more by reference to the syllogistic map. To reason successfully on a given topic, you need good major premises, good minor premises, and valid conclusions therefrom.

(a) A good stock of major premises is necessary, a good stock of rules and principles acquired in previous experience. Without some knowledge of a subject, you have only vague generalities to draw upon, and your reasoning process will be slow and probably lead only to indefinite conclusions.

Experience, knowledge, memory are important in reasoning, though they do not by any means guarantee success.

(b) The "detective instinct" for finding the right clues, and rejecting false leads, amounts to the same as sagacity in picking out the useful minor premises. In problem solution, you have to find both of your premises, and often the minor premise is the first to be found and in turn recalls the appropriate major premise. Finding the minor premise is a matter of observation, and if you fail to observe the significant fact about the problem, the really useful major premise may lie dormant, known and retained but not recalled, while false clues suggest inapplicable major premises and give birth to plenty of reasoning but all to no purpose. Some persons with abundant knowledge are ineffective reasoners from lack of a sense for probability. The efficient reasoner must be a good guesser.

(c) The reasoner needs a clear and steady mental eye, in order to see the conclusion that is implicated in the premises. Without this, he falls into confusion and fallacy, or fails, with the premises both before him, to get the conclusion. The "clear and steady mental eye", in less figurative language, means the ability to check hasty responses to either premise alone, or to extraneous features of the situation, so as to insure that "unitary response" to the combination of premises which constitutes the perceptive act of inference.

EXERCISES

1. Outline the chapter.
2. In what respects does the animal's solution of a problem fall short of reasoning?
3. Give a concrete instance of reasoning belonging under each of the types mentioned in the text.
4. How is it that superstitions such as that of Friday being an unlucky day persist? What would be the scientific way of testing such a belief?
5. What causes tend to arouse belief, and what to arouse doubt?
6. Introspective study of the process of thinking. Attempt to solve some of the following problems, and write down what you can observe of the process.
 - (a) What is it that has four fingers and a thumb, but no flesh or bone?
 - (b) Why does the full moon rise about sunset?
 - (c) If a book and a postage stamp together cost \$1.02, and the book costs \$1.00 more than the stamp, how much does the stamp cost?
 - (d) A riddle: "Sisters and brothers have I none, yet this man's father is my father's son."
 - (e) Prove that a ball thrown horizontally over level ground will strike the ground at the same time, no matter how hard it is thrown.
 - (f) If no prunes are atherogenous, but some bivalves are atherogenous, can you conclude that some prunes are not bivalves?
 - (g) Deduce, as impersonally as possible, the opinion of you held by some other person.

REFERENCES

- William James, *Principles of Psychology*, 1890, Vol. II, pp. 325-371.
John Dewey, *How We Think*, 1910.

CHAPTER XIX

IMAGINATION

MENTAL AS DISTINGUISHED FROM MOTOR MANIPULATION

From discovery we now turn to invention, from exploration to manipulation.

The human enterprise of exploration, which we have examined under the headings of perception and reasoning, as well as earlier under attention, runs the gamut from simple exploratory movements of the sense organs in looking and listening, to the elaborate scientific procedure followed in testing hypotheses and discovering the laws of nature. Inventive or manipulative activity runs a similar gamut from the child's play with his toys to the creation of a work of art, the designing of a work of engineering, the invention of a new machine, or the organization of a new government. The distinction between the two lines of activity is that exploration seeks what is there, and manipulation changes it to something else. Exploration seeks the facts as they exist, while invention modifies or rearranges the facts. The two enterprises go hand in hand, however, since facts must be known to be manipulated, while on the other hand manipulation of an object brings to light facts about it that could never be discovered by simple examination. Invention is based on science and also contributes to the advance of science.

Manipulation and exploration certainly go hand in hand in the little child's behavior. The baby picks up his new toy, turns it about and examines it on all sides, shakes it and is pleased if it makes a noise, drops it and is pleased

with its bang on the floor. This is manipulation, certainly; but it is also a way of exploring the properties of the toy.

BEGINNINGS OF IMAGINATION IN THE CHILD

Beginning with grasping, turning, pushing, pulling, shaking and dropping of objects, the child's manipulation develops in several directions. One line of development leads to *manual skill*. The child learns to manage his toys better.

A second line of development is in the direction of *constructiveness*. Taking things apart and putting them together, building blocks, assembling dolls and toy animals into "families" or "parties", setting table or arranging toy chairs in a room, are examples of this style of manipulation, which calls less for manual dexterity than for seeing ways in which objects can be rearranged.

Make-believe is a third direction followed in the development of manipulation. The little boy puts together a row of blocks and pushes it along the floor, asserting that it is a train of cars. The little girl lays her doll carefully in its bed, saying "My baby's sick; that big dog did bite him". This might be spoken of as "manipulating things according to the meanings attached to them", the blocks being treated as cars, and the doll as a sick baby.

Perhaps a little later than make-believe to make its appearance in the child is *story-telling*, the fourth type of manipulation. Where in make-believe he has an actual object to manipulate according to the meaning attached to it, in story-telling he simply talks about persons and things and makes them perform in his story. He comes breathless into the house with a harrowing tale of being pursued by a hippopotamus in the woods; or he gives a fantastic account of the doings of his acquaintances. For this he is sometimes accused of being a "little liar"—as indeed he

probably is when circumstances demand—and sometimes, more charitably, he is described as being still unable to distinguish observation from imagination; but really what he has not yet grasped is the *social* difference between his make-believe, which no one objects to, and his story-telling, which may lead people astray.

Both make-believe and story-telling are a great convenience to the child, since he is able by their means to manipulate big and important objects that he could not manage in sober reality. He thus finds an outlet for tendencies that are blocked in sober reality—blocked by the limitations of his environment, blocked by the opposition of other people, blocked by his own weakness and lack of knowledge and skill. Unable to go hunting in the woods, he can play hunt in the yard; unable to go to war with the real soldiers, he can shoulder his toy gun and campaign all about the neighborhood. The little girl of four years, hearing her older brothers and sisters talk of their school, has her own "home work" in "joggity", and her own graduation exercises.

PRELIMINARY DEFINITION OF IMAGINATION

In such ways as we have been describing, the little child shows "imagination", or mental manipulation. In story-telling the objects manipulated are simply *thought of*; in make-believe, though there is actual motor manipulation of present objects, the attached *meanings* are the important matter; and in construction there is apt to be a *plan* in mind in advance of the motor manipulation, as when you look at the furniture in a room and consider possible rearrangements.

The materials manipulated in imagination are usually facts previously perceived, and to be available for mental

manipulation they must now be recalled; but they are not merely recalled—they are rearranged and give a new result that may never have been perceived. A typical product of imagination is composed of parts perceived at different times and later recalled and combined, as a centaur is composed of man and horse, or a mermaid of woman and fish. Imagination is like reasoning in being a mental reaction; but it differs from reasoning in being manipulation rather than exploration; reasoning consists in seeing relationships that exist between facts, and imagination in putting facts into new relationships. These are but rough distinctions and definitions; we shall try to do a little better after we have examined a variety of imaginative performances.

“Imagination” and “invention” mean very much the same mental process, though “imagination” looks rather to the mental process itself, and “invention” more to the outcome of the process, which is a product having some degree of novelty and originality.

Imagination, like association and like attention, is sometimes free, and sometimes controlled. Controlled imagination is directed towards the accomplishment of some desired result, while free imagination wanders this way and that, with no fixed aim. Controlled imagination is seen in planning and designing; free imagination occurs in moments of relaxation, and may be called “play of the imagination”. The free variety, as the simpler, will be considered first.

Our study will have more point if we first remind ourselves what are the psychological *problems to be attacked* in studying any mental activity. What is the *stimulus*, and what the *response*? These are the fundamental questions. But the study of response breaks up into three subordinate questions, regarding the *tendency* that is awakened, regarding the

end-result obtained, and regarding the often complex *process*, or series of responses, that leads to the end-result.

The response in imagination we have already defined, in a general way, as mental manipulation, and the end-result as the placing of facts into new combinations or relationships. The stimulus consists of the facts, either perceived at the moment or recalled from past perception, that are now freshly related or combined. The more precise question regarding the stimulus is, then, as to what sort of facts make us respond in an inventive or imaginative way; and the more precise question regarding the end-result is as to what kind of combinations or new relationships are given to the facts—both pretty difficult questions. In regard to process, the great question is as to how any one can possibly escape from the beaten track of instinct and habit, and do anything new; and in regard to tendency the question is as to what motives are awakened in inventive activity and what satisfaction there is in the end-result. This last question, as to *why* we imagine, is about the easiest to answer.

PLAY

Free imagination was spoken of a moment ago as a kind of play; and we might turn this about and say that play, usually if not always, contains an element of imagination or invention. Sometimes the child makes up new games, very simple ones of course, to fit the materials he has to play with; but even when he is playing a regular game, he has constantly to adapt himself to new conditions as the game-situation changes. We may take the child's play as the first and simplest case of free invention and ask our questions regarding it. What are the child's play-stimuli (toys), how does he manipulate them, what end-results does he reach, and what satisfaction does he derive from play-

ing? We can ask these questions, but it is not so sure that we can answer them.

What is a toy? Anything to play with. But what characteristics of an object make it a real toy, which shall actually arouse the play response? First, it must be such that the child can move it; and almost anything that he can move serves, one time or another, for a plaything. But the surest stimulus is a *new* toy, the element of novelty and variety being important in arousing manipulation as it is in arousing exploration. However, to define a toy simply as something moveable, and also new if possible, fails to satisfy the spirit of inquiry, and about the only way to progress further is to make a long list of toys, and classify them from the psychological point of view. Thus we get the following classes of play-stimuli:

Little models of articles used by adults, such as tools, furniture, dishes; and we might include here dolls and toy animals. The child's response to this class of toys is imitative. Some psychologists have been so much impressed with the imitative play of children and animals (as illustrated by puppies playing fight), that they have conceived of all play as a sort of rehearsal for the serious business of life; but this conception does not apply very well to some of the other sorts of toy.

Noise-makers: rattle, drum, bell, horn, whistle, fire-cracker.

Things that increase your speed of locomotion, or that move you in unusual ways, as bicycle, skate, sled, rocking-horse, swing, seesaw, merry-go-round. Here belong also such sports as hopping, skipping, jumping, dancing, skipping rope, vaulting, leapfrog, whirling, somersault. The dizzy sensation resulting from stimulation of the semicircular canals is evidently pleasant to young children, and some of their sports seem aimed at securing a good measure of it.

Things that increase your radius of action; balls to throw or bat, bow and arrow, sling, mirror used to throw sunlight into a distant person's eyes; and we might include the bicycle here as well as in the preceding class.

Things that resist the force of gravity, floating, soaring, balancing, ascending, instead of falling; or that can be made to behave in this way. Here we have a host of toys and sports: balloons, soap bubbles, kites, rockets, boats, balls that bounce, tops that balance while they spin, hoops that balance while they roll, arrows shot high into the sky; climbing, walking on the fence, swimming, swinging, seesaw again.

Things that move in surprising ways or that are automatic: toy windmills, mechanical toys.

Things that can be opened and shut or readjusted in some similar way: a book to turn the leaves of, a door to swing or to hook and unhook, a bag or box to pack or unpack, water taps to turn on or off (specially on).

Plastic materials, damp sand, mud, snow; and other materials that can be worked in some way, as paper to tear or fold, stones or blocks to pile, load or build, water to splash or pour; and we might add here fire, which nearly every one, child or adult, likes to manage.

Finally, playmates should really be included in a list of playthings, since the presence of a playmate is often the strongest stimulus to arouse play.

Such being the stimulus, what is the play response? It consists in manipulating or managing the plaything so as to produce some interesting result. The hoop is made to roll, the kite to fly, the arrow to hit something at a distance, the blocks are built into a tower or knocked down with a crash, the mud is made into a "pie", the horn is sounded. Many games are variations on pursuit and capture (or escape): tag, hide-and-seek, prisoner's base, blind

man's buff, football, and we might include chess and checkers here. Wrestling, boxing, snowballing are variations on attack and defense. A great many are variations on action at a distance, of which instances have already been cited from children's toys; in adult games we find here golf, croquet, bowling, quoits, billiards, shooting. Many games emphasize motor skill, as skipping ropes, knife, cat's cradle, usually however with competition in skill between the different players. This element of manual skill enters of course into nearly all games. Mental acuteness appears in the guessing games, as well as in chess and many games of cards. Many games combine several of the elements mentioned, as in baseball we have action at a distance, pursuit and escape, motor skill and activity, and a chance for "head work".

THE PLAY MOTIVES

Now, what is the sense of games and toys, what satisfactions do they provide? What instincts or interests are thrown into activity? There is no one single "play instinct" that furnishes all the satisfaction, but conceivably every natural and acquired source of satisfaction is tapped in one play or another. In the games that imitate fighting, some of the joy of fighting is experienced, even though no real anger develops. In the games that imitate pursuit and escape, some of the joy of hunting and some of the joy of escape are awakened. In the "kissing games" that used to be common in young people's parties when dancing was frowned upon, and in dancing itself, some gratification of the sex instinct is undoubtedly present; but dancing also gives a chance for muscular activity which is obviously one source of satisfaction in the more active games. In fact, joy in motor activity must be counted as one of the most general sources of play-satisfaction. Another gen-

eral element is the love of social activity, which we see in dancing as well as in nearly all games and sports. Another, akin to the mere joy in motor activity, is the love of manipulation, with which we began this whole discussion.

The "escape motive" deserves a little more notice. Though you would say at first thought that no one could seek fear, and that this instinct could not possibly be utilized in play, yet a great many amusements are based on fear. The "chutes", "scenic railways", "roller coasters", etc., of the amusement parks would have no attraction if they had no thrill; and the thrill means fear. You get some of the thrill of danger, though you know that the danger is not very real. Probably the thrill itself would not be worth much, but being quickly followed by *escape*, it is highly satisfactory. The joy of escape more than pays for the momentary unpleasantness of fear. The fear instinct is utilized also in coasting on the snow, climbing, swimming, or any adventurous sport; in all of which there is danger, but the skilful player escapes by his own efforts. If he lost control he would get a tumble; and that is why the sport is exciting and worth while. He has his fear in check, to be sure, but it is awakened enough to make the escape from danger interesting. Nothing could be much further from the truth than to consider fear as a purely negative thing, having no positive contribution to make to human satisfaction. Though we try to arrange the serious affairs of life so as to avoid danger as much as possible, in play we seek such dangers as we can escape by skilful work. The fascination of gambling and of taking various risks probably comes from the satisfaction of the fear and escape motive.

But of all the "instincts", it is the self-assertive or masterful tendency that comes in oftenest in play. Competition, one form of self-assertion, is utilized in a tremendous number of games and sports. Either the players compete

as individuals, or they "choose sides" and compete as teams. No one can deny that the joy of winning is the high light in the satisfaction of play. Yet it is not the whole thing, for the game may have been worth while, even if you lose. Provided you can say, "Though I did not win, I played a good game", you have the satisfaction of having done well, which is the mastery satisfaction in its non-competitive form.

When the baby gets a horn, he is not contented to have somebody else blow it for him, but wants to blow it himself; and very pleased he is with himself when he can make it speak. "See what *I* can do!" is the child's way of expressing his feelings after each fresh advance in the mastery of his playthings. Great is the joy of the boy when he, himself, can make his top spin or his kite fly; and great is the girl's joy when she gets the knack of skipping a rope. Great is any one's joy when, after his first floundering, he comes to ride a bicycle, and the sense of power is enhanced in this case by covering distance easily, and so being master of a larger environment. As boys, I remember, we used to take great delight in the "apple thrower", which was simply a flexible stick, sharpened at one end to hold a green apple. With one's arm thus lengthened, the apple could be thrown to extraordinary distances, and to see *our* apple go sailing over a tall tree or striking the ground in the distance, gave a very satisfying sense of power. All of those toys that enable you to act at a distance, or to move rapidly, minister to the mastery impulse. Imitative play does the same, in that it enables the child to perform, in make-believe, the important deeds of adults. Children like to play at being grown-up, whether by wearing long dresses or by smoking, and it makes them feel important to do what the grown-ups do; you can observe how important they feel by the way they strut and swagger.

All in all, there are several different ways of gratifying the self-assertive or mastery impulse in play: always there is the toy or game-situation to master and manage; often self-importance is gratified by doing something big, either really or in make-believe; and usually there is a competitor to beat.

EMPATHY

There is still another possible way in which play may gratify the mastery impulse. Why do we like to see a kite flying? Of course, if it is *our* kite and we are flying it, the mastery impulse is directly aroused and gratified; but we also like to watch a kite flown by some one else, and similarly we like to watch a hawk, a balloon or aeroplane, a rocket. We like also to watch things that balance or float or in other ways seem to be superior to the force of gravity. Why should such things fascinate us? Perhaps because of *empathy*, the "feeling oneself into" the object contemplated. As "sympathy" means "feeling with", "empathy" means "feeling into", and the idea is that the observer projects himself into the object observed, and gets some of the satisfaction from watching an object that he would get from *being* that object. Would it not be grand to be a kite, would it not be masterful? Here we stand, slaves of the force of gravity, sometimes toying with it for a moment when we take a dive or a coast, at other times having to struggle against it for our very lives, and all the time bound and limited by it—while the kite soars aloft in apparent defiance of all such laws and limitations. Of course it fascinates us, since watching it gives us, by empathy, some of the sense of power and freedom that seems appropriate to the behavior of a kite. Perhaps the fascination of fire is empathy of a similar sort; for fire is power.

Having thus found the mastery impulse here, there, and

almost everywhere in the realm of play, we are tempted to assume a masterful attitude ourselves and say, "Look you! We have discovered the one and only play motive, which is none other than the instinct of self-assertion". Thus we should be forgetting the importance in play of danger and the escape motive, the importance of manipulation for its own sake, and the importance of the mere joy in muscular and mental activity. Also, we should be overlooking the occasional presence of laughter, the occasional presence of sex attraction, and the almost universal presence of the gregarious and other social motives. Play gratifies many instincts, not merely a single one.

Further, it is very doubtful whether the whole satisfaction of play activity can be traced to the instincts, anyway, for play may bring in the native "likes and dislikes", which we saw¹ to be irreducible to instinctive tendencies; and it may bring in acquired likes and interests developed out of these native likes. Play gives rise to situations that are interesting and attractive to the players, though the attraction cannot be traced to any of the instincts. The rhythm of dancing, marching, and of children's sing-song games can scarcely be traced to any of the instincts.

The sociability of games goes beyond mere gregariousness, since it calls for acting together and not simply for being together; and at the same time it goes beyond competition and self-assertion, as is seen in the satisfaction the players derive from good team work. It is true that the individual player does not lay aside his self-assertion in becoming a loyal member of a team; rather, he identifies himself with the team, and finds in competition with the opposing team an outlet for his mastery impulse. But at the same time it is obvious that self-assertion would be still more fully gratified by man-to-man contests; and therefore the

¹ See p. 180.

usual preference of a group of people for "choosing sides" shows the workings of some other motive than self-assertion. The fact seems to be that coördinated group activity is an independent source of satisfaction.

If the self-assertive impulse of an individual player is too strongly aroused, he spoils the game, just as an angry player spoils a friendly wrestling match or snowball fight, and just as a thoroughly frightened passenger spoils a trip down the rapids, which was meant to be simply thrilling. The instincts are active in play, but they must not be *too* active, for human play is an activity carried on well above the instinctive level, and dependent on motives that cannot wholly be analyzed in terms of the instincts.

DAY DREAMS

Daydreaming is a sort of play, more distinctly imaginative than most other play. Simply letting the mind run, as in the instances cited under free association, where A makes you think of B and B of C, and so on—this is not exactly daydreaming, since there is no "dream", no castle in the air nor other construction, but simply a passing from one recalled fact to another. In imaginative daydreaming, facts are not simply recalled but are rearranged or built together into a story or "castle" or scheme. A daydream typically looks toward the future, as a plan for possible doing; only, it is not a serious plan for the future—which would be controlled imagination—nor necessarily a plan which could work in real life, but merely play of imagination. If we ask the same questions here as we did regarding child's play, we find again that it is easier to define the end-result and the source of satisfaction in daydreaming than it is to define the stimulus or the exact nature of the imaginative process.

Daydreams have some motive force behind them, as can be judged from the absorption of the dreamer in his dream, and also from an examination of the end-results of this kind of imagination. Daydreams usually have a *hero*, and that hero is usually the dreamer's self. Sometimes one is the conquering hero, and sometimes the suffering hero, but in both cases the recognized or unrecognized merit of oneself is the big fact in the story, so that the mastery motive is evidently finding satisfaction here as well as in other forms of play. Probably the conquering hero dream is the commoner and healthier variety. A classical example is that of the milkmaid who was carrying on her head a pail of milk she had been given. "I'll sell this milk for so much, and with the money buy a hen. The hen will lay so many eggs, worth so much, for which I will buy me a dress and cap. Then the young men will wish to dance with me, but I shall spurn them all with a toss of the head." Her dream at this point became so absorbing as to get hold of the motor system and call out the actual toss of the head—but we are not after the moral just now; we care simply for the dream as a very true sample of many, many daydreams. Such dreams are a means of getting for the moment the satisfaction of some desire, without the trouble of real execution; and the desire gratified is very often some variety of self-assertion. Sometimes the hero is not the dreamer's self, but some one closely identified with himself. The mother is prone to make her son the hero of daydreams and so to gratify her pride in him.

The "suffering hero" daydream seems at first thought inexplicable, for why should any one picture himself as having a bad time, as misunderstood by his best friends, ill-treated by his family, jilted by his best girl, unsuccessful in his pet schemes? Why should any one make believe to be worse off than he is; what satisfaction can that

be to him? Certainly, one would say, the mastery motive could not be active here. And yet—do we not hear children *boasting* of their misfortunes? “Pooh! That’s only a little scratch; I’ve got a real deep cut.” My cut being more important than your scratch makes me, for the moment, more important than you, and gives me a chance to boast over you. Older people are known sometimes to magnify their own ailments, with the apparent aim of enhancing their own importance. Perhaps the same sort of motive underlies the suffering hero daydream.

I am smarting, let us suppose, from a slight administered by my friend; my wounded self-assertion demands satisfaction. It was a very little slight, and I should make myself ridiculous if I showed my resentment. But in imagination I magnify the injury done me, and go on to picture a dreadful state of affairs, in which my friend has treated me very badly indeed, and perhaps deserted me. Then I should not be ridiculous, but so deeply wronged as to be an important person, one to be talked about; and thus my demand for importance and recognition is gratified by my daydream.

Usually the suffering hero pictures himself as in the right, and animated by the noblest intentions, though misunderstood, and thus further enhances his self-esteem; but sometimes he takes the other tack and pictures himself as wicked—but as very, very wicked, a veritable desperado. It may be his self-esteem has been wounded by blame for some little meanness or disobedience, and he restores it by imagining himself a great, big, important sinner instead of a small and ridiculous one. In adolescence, the individual’s growing demand for independence is often balked by the continued domination of his elders, and he rebelliously plans quite a career of crime for himself. He’ll show them! They won’t be so pig-headedly complacent when they know they have driven him to the bad. You can tell by the looks of

a person whose feelings are hurt that he is imagining something; usually he is imagining himself either a martyr or a desperado, or some other kind of suffering hero, often working up into a conquering hero in the end, when, his self-esteem restored, he is ready to be friends again. The suffering hero daydream is a "substitute reaction", taking the place of a fight or some other active self-assertion. The conquering hero daydream is often motivated in the same way; for example, our friend the milkmaid would not have been so ready to scorn the young men with a toss of the head if she had not been feeling her own actual inferiority and lack of fine clothes. The daydream makes good, in one way or another, for actual inability to get what we desire.

The desire which is gratified in the play of imagination belongs very often indeed under the general head of self-assertion; but when one is in love it is apt to belong under that head. Love dreams of the agreeable sort need no further motivation; but the unpleasant, jealous type of love dream is at the same time a suffering hero dream, and certainly involves wounded self-assertion along with the sexual impulse. Probably the self-asserting daydream is the commonest variety, take mankind as a whole, with the love dream next in order of frequency. But there are many other sorts. There is the humor daydream, illustrated by the young person who suddenly breaks into a laugh and when you ask why replies that she was thinking how funny it would be if, etc., etc. She is very fond of a good laugh, and not having anything laughable actually at hand proceeds to imagine something. So, a music lover may mentally rehearse a piece when he has no actual music to enjoy; and if he has some power of musical invention, he may amuse himself, in idle moments, by making up music in his head; just as one who has some ability in decorative design may fill his idle moments by concocting new designs on paper.

When vacation time approaches, it is hard for any one, student or professor, to keep the thoughts from dwelling on the good times ahead, and getting some advance satisfaction. Thus all kinds of desires are gratified in imagination.

WORRY

Do we have fear daydreams, as we have amusements utilizing the fear and escape motive? Yes, sometimes we imagine ourselves in danger and plan out an escape. One individual often amuses himself by imagining he is arrested and accused of some crime, and figuring out how he could establish an alibi or otherwise prove his innocence. But fear daydreams also include *worry*, which seems at first to be an altogether unpleasant state of mind, forced upon us and not indulged in as most daydreams are. Yet, as the worry is often entirely needless, it cannot be said to be forced upon a person, but must have some motive. There must be some satisfaction in it, in spite of all appearance.

Some abnormal cases of worry suggest the theory that the fear is but a cloak for unacknowledged desire. Take this extreme case. A young man, "tied to the apron-strings" of a too affectionate and too domineering mother, has a strong desire to break loose and be an independent unit in the world; but at the same time, being much attached to his mother, he is horrified by this desire. She goes on a railroad journey without him—just an ordinary journey with no special danger—but all the time she is away he is in an agony of suspense lest the train may be wrecked. Such an abnormal degree of worry calls for explanation. Well—did not the worry perhaps conceal a wish, a wish that the train *might* be wrecked? So he would be set free without any painful effort on his part; and he

was a young man who shrank from all effort. The psychopathologist who studied the case concluded that this was really the explanation of the worry.

If, however, we take such extreme cases as typical and cynically apply this conception to all worries, we shall make many mistakes. A student worries unnecessarily about an examination; therefore, he desires to fail. A mother worries because her child is late in getting home; therefore, she wants to be rid of that child. Thus, by being too psychopathological, we reach many absurd conclusions in everyday life; for it is the child that is loved that is worried over, and it is the examination that the student specially wishes to pass that he fears he has flunked.

Worry is a sort of substitute reaction, taking the place of real action when no real action is possible. The student has done all he can do; he has prepared for the examination, and he has taken the examination; now there is nothing to do except wait; so that the rational course would be to dismiss the matter from his mind; if he cannot accomplish that, but must do something, then the only thing he can do is to speculate and worry. So also the mother, in her uncertainty regarding her child, is impelled to action, and if she knew of any real thing to do she would do it and not worry; but there is nothing to do, except in imagination. Worry is fundamentally due to the necessity of doing something with any matter that occupies our mind; it is an imaginative substitute for real action.

But worry may be something of an indoor sport as well. Consider this—if the mother really believed her child had fallen into the pond, she would rush to pull him out; but while she is worrying for fear he may have fallen in, she remains at home. Really she expects to see him come home any minute, but by conjuring up imaginary dangers she is getting ready to make his home-coming a great relief instead

of a mere humdrum matter. She is "shooting the chutes", getting the thrill of danger with escape fully expected.

The normal time for a daydream is the time when there is no real act to be performed. A strong man uses it as the amusement of an idle moment and promptly forgets it. But one who is lacking in force, especially the personal force needed in dealing with other people, may take refuge in daydreams as a substitute for real doing. Instead of hustling for the money he needs he may, like Micawber, charm himself with imagining the good opportunities that may turn up. Instead of going and making love to the lady of his choice, he shyly keeps away from her and merely dreams of winning her. He substitutes imaginary situations for the real facts of his life, and gratifies his mastery motive by imaginary exploits. He invents imaginary ailments to excuse his lack of real deeds. He conjures up imaginary dangers to worry over. All this is abuse of imagination.

DREAMS

Let us turn now from daydreams to dreams of the night. These also are play of imagination, even freer from control and criticism than the daydream. In sleep the cortical brain functions sink to a low level, and perhaps cease altogether in the deepest sleep. Most of the dreams that are coherent enough to be recalled probably occur just after we have gone to sleep or just before we wake up, or at other times when sleep is light. At such times the simpler and more practised functions, such as recall of images, can go on, though criticism, good judgment, reasoning, and all that sort of delicate and complex activity, do not occur. Day-time standards of probability, decorum, beauty, wit, and excellence of any sort are in abeyance; consistency is thrown to the winds, the scenes being shifted in the middle of a

speech, and a character who starts in as one person merging presently into somebody else. Dreams follow the definition of imagination or invention, in that materials recalled from different contexts are put together into combinations and rearrangements never before experienced. The combinations are often bizarre and incongruous.

Perhaps the most striking characteristic of dreams is their seeming reality while they last. They seem real in spite of their incongruity, because of the absence of critical ability during sleep. In waking life, when the sight of one object reminds me of another and calls up an image of that other, I know that the image is an image, and I know I have thought of two different things. In sleep the same recall by association occurs, but the image is forthwith accepted as real; and thus things from different sources get together in the same dream scene, and a character who reminds us of another person forthwith becomes that other person. We are not mentally active enough in sleep to hold our images apart. Associative recall, with blending of the recalled material, and with entire absence of criticism, describes the process of dreaming.

What is the *stimulus*, to which the dream responds? Sometimes there is an actual sensory stimulus, like the alarm clock or a stomach ache; and in this case the dream comes under the definition of an illusion; it is a false perception, more grotesquely false than most illusions of the day. A boy wakes up one June morning from a dream of the Day of Judgement, with the last trump pealing forth and blinding radiance all about—only to find, when fully awake, that the sun is shining in his face and the brickyard whistle blowing the hour of four-thirty A.M. This was a false perception. More often, a dream resembles a day-dream in being a *train of thoughts and images* without much relation to present sensory stimuli; and then the dream

would come under the definition of hallucination instead of illusion.

Sometimes a sensory stimulus breaks in upon a dream that is in progress, and is interpreted in the light of this dream. In one experiment, the dreamer, who was an authoress, was in the midst of a dream in which she was discussing vacation plans with a party of friends, when the experimenter disturbed her by declaiming a poem; in her dream this took the form of a messenger from her publisher, reciting something about a contract which seemed a little disturbing but which she hoped (in the dream) would not interfere with her vacation. Maury, an early student of this topic, was awakened from a feverish dream of the French Revolution by something falling on his neck; this, under the circumstances, he took to be the guillotine.

Now, *why* is a dream? What satisfaction does it bring to the dreamer? Or shall we say that it is merely a mechanical play of association, with no motivation behind it? Dreams are interesting while they last, sometimes fearful, sometimes angry, sometimes amorous, otherwise not very emotional but distinctly interesting, so that many people hate to have a dream broken up by awaking. It seems likely, then, that dreams are like daydreams in affording gratification to desires. They are "wish-fulfilling", to borrow a term from Freud's theory of dreams, soon to be considered.

A boy dreams repeatedly of finding whole barrels of assorted jackknives, and is bitterly disappointed every time to awake and find the knives gone; so that finally he questions the reality of the dream, but pinching himself (in the dream) concludes he must be awake this time. An adult frequently dreams of finding money, first a nickel in the dust, and then a quarter close by, and then more and more, till he wakes up and spoils it all. Such dreams are obvi-

ously wish-fulfilling, as are also the sex dreams of sexually abstinent persons, or the feasting dreams of starving persons, or the polar explorer's recurring dream of warm, green fields. An eminent psychologist has given a good account of a dream which he had while riding in an overcrowded compartment of a European train, with the window closed and himself wedged in tightly far from the window. In this uncomfortable situation he dropped asleep and dreamed that he had the seat next to the window, had the window open and was looking out at a beautiful landscape. In all these cases *the wish gratified in the dream is one that has been left unsatisfied in the daytime*, and this is according to the famous passage, slightly paraphrased, "What a man hath, why doth he yet dream about?" The newly married couple do not dream of each other. We seldom dream of our regular work, unless for some reason we are disturbed over it. The tendencies that are satisfied during the day do not demand satisfaction in dreams; but any tendency that is aroused during the day without being able to reach its conclusion is likely to come to the surface in a dream.

Any sort of desire or need, left unsatisfied in the day, may motivate a dream. Desire for food, warmth, sex gratification, air, money, etc., have been exemplified in dreams already cited. Curiosity may be the motive, as in the case of an individual, who, having just come to live in Boston, was much interested in its topography, and who saw one day a street car making off in what seemed to him a queer direction, so that he wondered where it could be going and tried unsuccessfully to read its sign. The next night he dreamed of seeing the car near at hand and reading the sign, which, though really consisting of nonsense names, satisfied his curiosity during the dream.

The mastery motive, so prominent in daydreams, can be detected also in many sleep dreams. There are dreams in

which we do big things—tell excruciatingly funny jokes, which turn out when recalled next day to be utterly flat; or improvise the most beautiful music, which we never can recall with any precision, but which probably amounted to nothing; or play the best sort of baseball. The gliding or flying dream, which many people have had, reminds one of the numerous toys and sports in which defiance of gravity is the motive; and certainly it gives you a sense of power and freedom to be able, in a dream, to glide gracefully up a flight of stairs, or step with ease from the street upon the second-story balcony. One dream which at first thought cannot be wish-fulfilling perhaps belongs under the mastery motive: The dreamer sees people scurrying to cover, looks up and sees a thunderstorm impending; immediately he is struck by lightning and knocked down in the street; but he finds he can rise and walk home, and seems to have suffered no harm except for a black blotch around one eye. Now, any man who could take lightning that way would be proud to wear the scar. So the dream was wish-fulfilling, and the wish involved was, as often, the self-assertive impulse.

This last dream is a good one, however, for pointing another moral. We need not suppose that the dreamer was aiming at the dénouement from the beginning of the dream. Dreams have no plot in most instances; they just drift along, as one thing suggests another. The sight of people running to cover suggested a thunderstorm, and that suggested that "I might get struck", as it would in the daytime. Now, the dream mentality, being short on criticism, has no firm hold on "may be" and "might be", but slides directly into the present indicative. The thought of being struck is *being* struck, in a dream. So we do not need to suppose that the dreamer pictured himself as struck by lightning in order to have the satisfaction of coming off

whole and bragging of the exploit. In large measure the course of a dream is determined by free association; but the mastery motive and other easily awakened desires act as a sort of bias, facilitating certain outcomes and inhibiting others.

But there are unpleasant dreams, as well as pleasant. There are fear dreams, as well as wish dreams. A child who is afraid of snakes and constantly on the alert against them when out in the fields during the day, dreams repeatedly of encountering a mass of snakes and is very much frightened in his sleep. Another child dreams of wolves or tigers. A person who has been guilty of an act from which bad consequences are possible dreams that those consequences are realized. The officer suffering from nervous war strain, or "shell shock", often had nightmares in which he was attacked and worsted by the enemy. Since Freud has never admitted that dreams could be fear-motived, holding that here, as in worry, the fear is but a cloak for a positive desire, some of his followers have endeavored to interpret these shell-shock nightmares as meaning a desire to be killed and so escape from the strain. To be consistent, they would have also to hold that the child, who of all people is the most subject to terrifying dreams, secretly desires death, though not avowing this wish even to himself. This would be pushing consistency rather far, and it is better to admit that there are real fear dreams, favored by indigestion or nervous strain, but sometimes occurring simply by the recall of a fear-stimulus in the same way that anything is recalled, i.e., through association.

A large share of dreams does not fit easily into any of the classes already described. They seem too fantastic to have any personal meaning. Yet they are interesting to the dreamer, and they would be worth going to see if they could be reproduced and put on the stage. Isn't that sufficient

excuse for them? May they not be simply a free play of imagination that gives interesting results because of its very freedom from any control or tendency, and because of the vividness of dream imagery?

FREUD'S THEORY OF DREAMS

Just at this point we part company with Freud, whose ideas on dreams as wish-fulfillments we have been following, in the main. Not that Freud would O K our account of dreams up to this point. Far from it. It would seem to him on too superficial a level altogether, dealing as it does with conscious wishes and with straightforward fulfillments. It has left out of account the "Unconscious" and its symbolisms. The Freudian would shake his head at our interpretation of the lightning dream, and say, "Oh, there is a good deal more in that dream. We should have to analyze that dream, by letting the dreamer dwell on each item of it and asking himself what of real personal significance the stroke of lightning or the scar around the eye suggested to him. He would never be able by his unaided efforts to find the unconscious wishes fulfilled in the dream, but under the guidance of the psychoanalyst, who is a specialist in all matters pertaining to the Unconscious, he may be brought to realize that his dream is the symbolic expression of wishes that are unconscious because they have been suppressed".

The Unconscious, according to Freud, consists of forbidden wishes—wishes forbidden by the "Censor", which represents the moral and social standards of the individual and his critical judgment generally. When the Censor suppresses a wish, it does not peaceably leave the system but sinks to an unconscious state in which it is still active and liable to make itself felt in ways that get by the Censor because they are disguised and symbolic. An abnormal worry

is such a disguise, a queer idea that haunts the nervous person is another, "hysterical" paralysis or blindness is another.

In normal individuals the dream life is held by Freud to be the chief outlet for the suppressed wishes; for then the Censor sleeps and "the mice can play". Even so, they dare not show themselves in their true shape and color, but disguise themselves in innocent-appearing symbolism. That lightning may stand for something much more personal. Let your mind play about that "being knocked down by lightning and getting up again", and ask yourself what experience of childhood it calls up.—Well, I remember the last time my father whipped me and I came through defiant, without breaking down as I always had before on similar occasions.—Yes, now we are on the track of something. The lightning symbolizes your father and his authority over you, which as a child you resented. You were specially resentful at your father's hold on your mother, whom you regarded as yours, your father being a rival with an unfair advantage. Your sex impulse was directed towards your mother, when you were a mere baby, but you soon came to see (how, Freud has never clearly explained) that this was forbidden, and that your father stood in the way. You resented this, you hated your father, while at the same time you may have loved him, too; so this whole complex and troublesome business was suppressed to the Unconscious, whence it bobs up every night in disguise. You may dream of the death of some one, and on analysis that some one is found to represent your father, whom as a child you secretly wished out of the way; or that some one may stand for your younger brother, against whom you had a standing grudge because he had usurped your place as the pet of the family. These childish wishes are the core of the Unconscious and help to motivate all dreams, but more recently suppressed

wishes may also be gratified in dream symbolism. A man may "covet his neighbor's wife", but this is forbidden, unworthy, and false to the neighbor who is also his friend. The wish is disavowed, suppressed, not allowed in the waking consciousness; but it gratifies itself symbolically in a dream; the neighbor's wife not appearing at all in the dream, but the neighbor's automobile instead, which the neighbor cannot run properly, while the dreamer manages it beautifully.

Freud has claimed the dream as his special booty, and insists that all dreams are wish-fulfillments, even those that seem mere fantastic play of imagination, since, as he sees it, no mental activity could occur except to gratify some wish. Further, he holds, most if not all dreams are fulfillments of suppressed wishes, and these are either sex or spite wishes, the spite wishes growing out of the interference of other people with our sex wishes.

The objection to Freud's theory of dreams is, first, that he fails to see how easy-running the association or recall mechanism is. It isn't necessary to look for big, mysterious driving forces, when we know that A makes you think of B, and B of C, with the greatest ease. The dreamer isn't laboring, he is idly playing, and his images come largely by free association, with personal desires giving some steer.

Another objection is that Freud overdoes the Unconscious; suppressed wishes are usually not so unconscious as he describes them; they are unavowed, unnamed, unanalyzed, but conscious for all that. It is not so much the unconscious wish that finds outlet in dreams and daydreams, as the unsatisfied wish, which may be perfectly conscious.

Another very serious objection to Freud is that he overdoes the sex motive or "libido". He says there are two main tendencies, that of self-preservation and that of reproduction, but that the former is ordinarily not much subject to suppression, while the latter is very much under the

social ban. Consequently the Unconscious consists mostly of suppressed sex wishes. Evidently, however, Freud's analysis of human motives is very incomplete. He does not clearly recognize the self-assertive tendency, which, as a matter of fact, is subjected to much suppression from early childhood all through life, and which undoubtedly has as much to do with dreams, as it has with daydreams. Freud has given an "impressionistic" picture, very stimulating and provocative of further exploration, but by no means to be accepted as a true and complete map of the region.

AUTISTIC THINKING

Dreaming, whether awake or asleep, is free imagination. It does not have to check up with any standard. So long as it is interesting at the moment and gratifies the dreamer in any way, it serves its purpose. Sometimes the day-dreamer exercises some control, breaking off a spiteful or amorous dream because he thinks it had better not be indulged; but in this he ceases to be simply a daydreamer. Daydreaming, by itself, is an example of what is called "autistic thinking", which means thinking that is sufficient unto itself, and not subjected to any criticism. Autistic thinking gratifies some desire and that is enough for it. It does not submit to criticism from other persons nor from other tendencies of the individual, nor does it seek to square itself with the real world.

Autistic thinking, indulged in by every imaginative person in moments of relaxation, is carried to an absurd extreme by some types of insane individuals. One type withdraws so completely from reality as to be inaccessible in the way of conversation, unresponsive to anything that happens, entirely immersed in inner imaginings. Others, while living in the world about them, transform it into a make-believe

world by attaching meanings to things and persons as suits themselves. This institution, in which the subject is confined, is his royal palace, the doctors are his officials, the nurses his wives, "thousands of them, the most beautiful women in creation". Or the delusion may take the line of the "suffering hero", the subject imagining himself a great man shut up in this place by the machinations of his enemies; the doctors are spies and enemy agents, and the nurses also act suspiciously; his food is poisoned, and he is kept in a weak and helpless condition, all out of fear of him. It is impossible to argue the patient out of his delusions by pointing out to him how clearly they conflict with reality; he evades any such test by some counter-argument, no matter how flimsy, and sticks to his dream or make-believe.

Autistic thinking is contrasted with realistic thinking, which seeks to check up with real facts; it may be contrasted also with socialized thinking, which submits to the criticism of other people; and it may even be contrasted with self-criticized thinking, in which the individual scrutinizes what he has imagined, to see whether it is on the whole satisfactory to himself, or whether it simply gratified a single or momentary impulse that should be balanced off by other tendencies.

INVENTION AND CRITICISM

"Criticism"—the word has been used repeatedly, and it is time it gave an account of itself. Criticism evidently demands balancing off one desire by another. One tendency gets criticized by running afoul of another tendency, one idea by conflicting with another idea. We concoct a fine joke to play on our friend; but then the thought comes to us that he may not take it kindly; we don't want to break with our friend, and so we regretfully throw our promising invention on the scrap heap. That is self-criticism, the

balancing off of one impulse by another. Self-criticism is obnoxious to the natural man, who prefers to follow out any tendency that has been aroused till it reaches its goal; but he learns self-criticism in the hard school of experience. For plenty of criticism is directed upon the individual from without.

Criticism is directed upon him by the facts of the real world, so soon as he tries to act out what he has imagined. Often his invention will not work, his plan does not succeed, and he is involved in chagrin and even pain. He must perforce cast away his plan and think up a new one. At this point the "weak brother" is tempted to give up trying, and take refuge in autistic thinking, but the stronger individual accepts the challenge of reality. He sees that an invention is not satisfactory unless it will really work, and sets about learning what will work and what not, so accumulating observations that later enable him to criticize his own ideas, to some extent, before trying them out on real things.

Criticism is directed upon the individual from the side of other people, who from the day he first begins to tell his childish imaginings, are quite free with their objections. Humiliated by this critical reception of his ideas, the individual may resolve to keep them to himself for the future, and draw away, again, towards autistic thinking; or, more forcefully, he may exert himself to find some idea that will command the approval of other people. If he can take rebuffs goodnaturedly, he soon finds that social criticism can be a great help, that two heads are better than one in planning any invention that needs to work. He accumulates knowledge of what will pass muster when presented to other people, and thus again learns self-criticism.

Self-criticism is helped by such rules as to "think twice", to "sleep on it before deciding", to "drop the matter for a time and come back to it and see whether it still looks

the same". When you are all warmed up over an idea, its recency value gives it such an advantage over opposing ideas that they have no chance, for the moment, of making themselves felt in the line of criticism.

I once heard the great psychologist, and great writer, William James, make a remark that threw some light on his mode of writing. In the evening, he said, after warming up to his subject, he would write on and on till he had exhausted the lead he was following, and lay the paper aside with the feeling, "Good! Good! That's good". The next morning, he said, it might not seem good at all. This calls to mind the old advice to writers about its being "better to compose with fury and correct with phlegm than to compose with phlegm and correct with fury". The phlegmatic critical attitude interferes considerably with the enthusiastic inventive activity. Give invention free rein for the time being, and come around with criticism later.

Some over-cautious and too self-critical persons, though rather fertile in ideas, never accomplish much in the way of invention because they cannot let themselves go. Criticism is always at their elbow, suggesting doubts and alternatives and preventing progress in the creative activity, instead of biding its time and coming in to inspect the completed result. For a similar reason, much of the best inventive work—writing, for example, or painting—is done in prolonged periods of intense activity, which allow time for invention to get warmed to its task, when it takes the bit in its teeth and dashes off at a furious speed, leaving criticism to trail along behind.

Invention in the service of art or of economic and social needs is controlled imagination, realistic, socialized, subjected to criticism. It cannot afford to be autistic, but must meet objective or social standards. Mechanical inventions must work when translated into matter-of-fact wood and iron, and

must also pass the social test of being of some use. Social inventions of the order of institutions, laws, political platforms and slogans, plans of campaign, must "work" in the sense of bringing the desired response from the public. Social imagination of the very important sort suggested by the proverbs, "Seeing ourselves as others see us", or "Putting ourselves in the other fellow's place"—for it is only by imagination that we can thus get outside of our own experience and assume another point of view—must check up with the real sentiments of other people.

THE ENJOYMENT OF IMAGINATIVE ART

It requires imagination to enjoy art as well as to produce it. The producer of the work of art puts the stimuli before you, but you must make the response yourself, and it is an inventive response, not a mere repetition of some response you have often made. The novelist describes a character for you, and you must respond by putting together the items in the description so as to conceive of a character you have never met. The painter groups his figures before you, but you must get the point of the picture for yourself. The musical composer provides a series of chords, but you must get the "hang" of the passage for yourself, and if he has introduced a novel effect, it may not be easy to find any beauty in it, at least on the first hearing.

Art, from the consumer's side, is play. It is play of the imagination, with the materials conveniently presented by the artist. Now, as art is intended to appeal to a consumer (or enjoyer), the question as to sources of satisfaction in the enjoyment of art is fundamental in the whole psychology of art, production as well as consumption.

We have the same questions to ask regarding the enjoyment of a *novel* as regarding a daydream. Novel-reading is daydreaming with the materials provided by the

author, and gratifies the same motives. A novel to be really popular must have a genuine hero or heroine—some one with whom the reader can identify himself. The frequency of novels in which the hero or heroine is a person of high rank, or wins rank or wealth in the course of the story, is a sign of appeal to the mastery motive. The humble reader is tickled in his own self-esteem by identifying himself for the time with the highborn or noble or beautiful character in the story. The escape motive also is relied upon to furnish the excitement of the story, which always brings the hero into danger or difficulty and finally rescues him, much to the reader's relief. Love stories appeal, of course, to the sex impulse, humorous stories to laughter, and mystery stories to curiosity. Cynical stories, showing the "pillars of society" in an ignoble light, appeal to the self-assertive impulse of the reader, in that he is led to apply their teaching to pretentious people whom he knows about, and set them down a peg, to his own relative advancement. But here again we have to insist, as under the head of sports and daydreams, that interests of a more objective kind are also gratified by a good work of fiction. A story that runs its logical course to a tragic end is interesting as a good piece of workmanship, and as an insight into the world. We cannot heartily identify ourselves with Hamlet or Othello, yet we should be sorry to have those figures erased from our memories; they mean something, they epitomize world-facts that compel our attention.

The appeal of art is partly emotional. A very great work of art, the Apollo Belvedere or the Sistine Madonna, when you suddenly come upon it in walking through a gallery, may move you almost or quite to tears. Beautiful music, and not necessarily sad music either, has the same effect. Why this particular emotion should be aroused is certainly an enigma. "Crying because you are so happy" is similar

but itself rather inexplicable. In many other cases, the emotional appeal of art is easily analyzed. The pathetic appeals straightforwardly to the grief impulse, the humorous to the laughter impulse, the tragic to fear and escape. The sex motive is frequently utilized in painting and sculpture as well as in literature.

Art makes also an intellectual appeal. It is satisfying partly because of this appeal, as is clear when we remember that many great works of art require mental effort in order to grasp and appreciate them. You must be wide-awake to follow a play of Shakespeare; you must puzzle out the meaning of a group painting before fully enjoying it; you must study some of the detail of a Gothic cathedral before getting the full effect; music may be too "classical" for many to grasp and follow. Unless, then, the artist has made a great mistake, the mental activity which he demands from his public must contribute to the satisfaction they derive from his works. If his appeal were simply to their emotions, any intellectual labor would be a disturbing element. The intellectual appeal is partly to objective interests in the thing presented, partly to interest in the workmanship, and partly to the mastery motive in the form of problem solution.

Perhaps we do not often think of a fine painting or piece of music as a problem set us for solution, but it is that, and owes part of its appeal to its being a problem. To "get the hang of" a work of art requires some effort and attention; if the problem presented is too difficult for us, the work of art is dry; if too easy, it is tame.

The mastery motive is probably as important in the enjoyment of art as it is in play and dreaming. It comes in once in the joy of mastering the significance of the work of art, and again in self-identification with the fine characters portrayed.

Empathy in art enjoyment. At first thought, some forms of art, as architecture, seem incapable of making the just-mentioned double appeal to the mastery motive. Architecture can certainly present problems for the beholder to solve, but how can the beholder possibly identify himself with a tower or arch? If, however, we remember the "empathy" that we spoke of under the head of play, we see that the beholder may project himself into the object, unintentionally of course, and thus perhaps get satisfaction of his mastery impulse.

Look at a pillar, for example. If the pillar is too massive for the load supported, it gives you the unsatisfactory impression of doing something absurdly small for your powers. If on the contrary the pillar is too slender for the load that seems to rest upon it, you get the feeling of strain and insecurity; but if it is rightly proportioned, you get the feeling of a worthy task successfully accomplished. The pillar, according to empathy, pleases you by arousing and gratifying your mastery impulse; and many other architectural effects can be interpreted in the same way.

Empathy can perhaps explain the appeal of the *big* in art and nature. In spite of the warnings put forth against thinking of mere bigness as great or fine, we must admit that size makes a very strong appeal to something in human nature. The most perfect miniature model of a cathedral, however interesting and attractive as it rests on the table before you, fails to make anything like the impression that is made by the giant building towering above you. Big trees, lofty cliffs, grand canyons, tremendous waterfalls, huge banks of clouds, the illimitable expanse of the sea, demonstrate cogently the strong appeal of the big. Perhaps the big is not necessarily grand, but the grand or sublime must be big or somehow suggest bigness. The question is, then, what it is in us that responds to the appeal of the big.

Perhaps it is the submissive tendency that is aroused. This great mountain, so far outclassing me that I am not tempted in the least to compete with it, affords me the joy of willing submission. The escape motive may come in along with submissiveness—at the first sight of the mountain a thrill of fear passes over me, but I soon realize that the mountain will not hurt me in spite of its awe-inspiring vastness; so that my emotion is blended of the thrill of fear, the relief of escape, and the humble joy of submission. That is one analysis of the esthetic effect of bigness.

Empathy suggests a very different analysis. According to this, projecting myself into the mountain, identifying myself with it, I experience the sensation of how it feels to be a mountain. It feels big—I feel big. My mastery impulse is gratified. To decide between these two opposing interpretations ought to be possible from the behavior or introspection of a person in the presence of some big object. If he feels insignificant and humble and bows reverently before the object, we may conclude that the submissive tendency is in action; but if the sight of the grand object makes him feel strong and fine, if he throws out his chest and a gleam comes into his eye, then everything looks like the mastery motive. Quite possibly, the effect varies with the person and the occasion.

We have to think of art as a great system or collection of inventions that owes its existence to its appeal to human nature, and that has found ways, as its history has progressed, of making its appeal more and more varied. Art is a type in these respects of many social enterprises, such as sport, amusement, and even such serious matters as politics and industry. Each of these is a collection of inventions that persists because it appeals to human impulses, and each one appeals to a variety of different impulses.

THE PSYCHOLOGY OF INVENTIVE PRODUCTION

To the consumer, art is play, but to the producer it is work, in the sense that it is directed towards definite ends and has to stand criticism according as it does or does not reach those ends. What is true of the producer of art works is true also of other inventors, and we may as well consider all sorts of controlled imagination together.

In spite of the element of control that is present in productive invention, the really gifted inventor seems to make play of his work to a large extent. Certainly the inventive genius does not always have his eyes fixed on the financial goal, nor on the appeal which his inventions are to make to the public. It is astonishing to read in the lives of inventors what a lot of comparatively useless contrivances they busied themselves with, apparently from the pure joy of inventing. One prolific writer said that he "never worked in his life, only played". The inventor likes to manipulate his materials, and this playfulness has something to do with his originality, by helping to keep him out of the rut.

That "necessity is the mother of invention" is only half of the truth; it points to the importance of a directive tendency, but fails to show how the inventor manages to leave the beaten path and really invent. Necessity, or some desire, puts a question, without which the inventor would not be likely to find the answer; but he needs a kind of flexibility or playfulness, just because his job is that of seeing things in a new light. We must allow him to toy with his materials a bit, and even to be a bit "temperamental", and not expect him to grind out works of art or other inventions as columns of figures are added.

When inventive geniuses have been requested to indicate their method, they have been able to give only vague hints. How does the musical composer, for example, free himself of

all the familiar pieces and bring the notes into a fresh arrangement? All that he can tell about it is usually that he had an "inspiration"; the new air simply came to him. Now, of course the air did not really come to him from outside; he made it, it was his reaction, but it was a quick, free reaction, of which he could observe little introspectively.

Perhaps the best-studied case of invention is that of the learner in typewriting, who, after laboriously perfecting his "letter habits" or responses to single letters by appropriate finger movements on the keyboard, may suddenly find himself writing in a new way, the word no longer being spelled out, but being written as a unit by a coördinated series of finger movements. The amazing thing is that, without trying for anything of the kind, he has been able to break away from his habit of spelling out the word, and shift suddenly to a new manner of writing. He testifies that he did not plan out this change, but was surprised to find himself writing in the new way. He was feeling well that day, hopeful and ambitious, he was striving for greater speed, and, while he was completely absorbed in his writing, this new mode of reaction originated.

We see in this experimentally studied case some of the conditions that favor invention. Good physical condition, freshness, mastery of the subject, striving for some result, and "hopefulness". Now, what is that last? Confidence, enterprise, willingness to "take a chance", eagerness for action and readiness to break away from routine? Some of this independent, manipulating spirit was probably there.

A soldier, so wounded as to paralyze his legs but capable of recovery by training, had advanced far enough to hobble about with a cane and by holding to the walls. One morning, feeling pretty chipper, he took a chance and left the wall, cutting straight across the room; and getting through without a fall, was naturally much encouraged and main-

tained this advance. This might be called invention; it was breaking away from what had become routine, and that is the essential fact about the inventive reaction. This playful spirit of cutting loose, manipulating, and rearranging things to suit yourself is certainly a condition favorable to invention. It does not guarantee a valuable invention, but it at least helps towards whatever invention the individual's other qualifications make possible.

Another condition favorable to invention is youth. Seldom does a very old person get outside the limits of his previous habits. Few great inventions, artistic or practical, have emanated from really old persons, and comparatively few even from the middle-aged. On the other hand, boys and girls under eighteen seldom produce anything of great value, not having as yet acquired the necessary mastery of the materials with which they have to deal. The period from twenty years up to forty seems to be the most favorable for inventiveness.

IMAGINATION CONSIDERED IN GENERAL ..

Finally, we must return to the question of definition or general description that was left open near the beginning of the chapter. There seem to be two steps in the inventive response, one preliminary, the other strictly inventive. The preliminary step brings the stimuli to bear, and invention is the response that follows.

Typically, the preliminary stage consists in recall; and association by similarity, bringing together materials from different past experiences, is very important as a preliminary to invention. Facts recalled from different contexts are thus brought together, and invention consists in a response to such novel combinations of facts. The two steps in invention are, first, getting a combination of stimuli, and second, responding to the combination.

Sometimes it has been said that imagination consists in putting together material from different sources, but this leaves the matter in mid-air; recall can bring together facts from different sources and so afford the stimulus for an imaginative response, but the response goes beyond the mere togetherness of the stimuli. Thinking of a man and also of a horse is not inventing a centaur; there is a big jump from the juxtaposition of the data to the specific arrangement that imagination gives them. The man plus the horse may give no response at all, or may give many other responses besides that of a centaur; for example, a picture of the man and the horse politely bowing to each other. The particular manipulation, or imaginative response, that is made varies widely; sometimes it consists in taking things apart rather than putting them together, as when you imagine how a house would look with the evergreen tree beside it cut down; always it consists in putting the data into new relationships.

Imagination thus presents a close parallel to reasoning, where, also, there are two stages, the preliminary consisting in getting the premises together and the final consisting in perceiving the conclusion. The final response in imagination is in general like that in reasoning; both are *perceptive reactions*; but imagination is freer and more variable. Reasoning is governed by a very precise aim, to see the actual meaning of the combined premises; that is, it is exploratory; while imagination, though it is usually more or less steered either by a definite aim or by some bias in the direction of agreeable results, has after all much more latitude. It is seeking, not a relationship that is there, but one that can be put there.

EXERCISES

1. Outline the chapter.
2. Make a list of hobbies and amusements that you specially enjoy, and try to discover the sources of satisfaction in each.
3. Recall two stories that you specially enjoyed, and try to discover the sources of satisfaction in each.
4. How far does the account of daydreams given in the text square with your own daydreams, and how far does it seem inadequate?
5. An experiment on the speed of reverie or of daydreaming. Beginning at a recorded time, by your watch, let your mind wander freely for a few moments, stopping as soon as your stream of thoughts runs dry. Note the time at the close. Now review your daydream (or reverie), and tally off the several scenes or happenings that you thought of, so as to count up and see how many distinct thoughts passed through your mind. How many seconds, on the average, were occupied by each successive item?
6. Why do dreams seem real at the time?
7. Analysis of a dream. Take some dream that you recall well, and let your thoughts play about it, and about the separate items of it—about each object, person, speech, and happening in the dream—with the object of seeing whether they remind you of anything personally significant. Push the analysis back to your childhood, by asking whether anything about the dream symbolizes your childish experiences or wishes. To be sure, the psychoanalyst would object that the individual cannot be trusted to make a complete analysis of his own dream—just as the psychologist would object to your accepting the recalled experiences and wishes as necessarily standing in any causal relation to your dream—but, at any rate, the exercise is interesting.
8. Problems in invention. Solve some of these, and compare the mental process with that of reasoning.
 - (a) Devise a game to be played by children and adults together, to everybody's satisfaction.
 - (b) Imagine a weird animal, after the analogy of the centaur.
 - (c) Imagine an interesting incident, bringing in an old man, a little girl, and a waterfall.
 - (d) Design the street plan for an ideal small town, built on both sides of a small river.
9. Show how empathy might make us prefer a symmetrical building to one that is lop-sided.

REFERENCES

On the imagination and play of children, see Norsworthy and Whitley's *Psychology of Childhood*, 1918, Chapters IX and XII.

For Freud's views regarding dreams, see his *Interpretation of Dreams*, translated by Brill, 1913.

For a view which, though psychoanalytical, diverges somewhat from that of Freud, see Maurice Nicoll, *Dream Psychology*, 1917; also C. W. Kimmins, *Children's Dreams*, 1920.

For studies of play, see Edward S. Robinson, "The Compensatory Function of Make-Believe Play", in the *Psychological Review* for 1920, Vol. 27, pp. 429-439; also M. J. Reaney, *The Psychology of the Organized Group Game*, 1916.

On invention, see Josiah Royce, "The Psychology of Invention", in the *Psychological Review* for 1898, Vol. 5, pp. 113-144; also F. W. Taussig's *Inventors and Money-Makers*, 1915.

CHAPTER XX

WILL

PLANNED ACTION, ACTION IN SPITE OF INTERNAL CONFLICT, AND ACTION AGAINST EXTERNAL OBSTRUCTION

If the psychologist were required to begin his chapter on the will with a clean-cut definition, he would be puzzled what to say. He might refer to the old division of the mind into the "three great faculties" of intellect, feeling, and will, but would be in duty bound to add at once that this "tripartite division" is now regarded as rather useless, if not misleading. It is misleading if it leads us to associate will exclusively with motor action, for we also have voluntary attention and voluntary control in reasoning and inventing, and we have involuntary motor reactions. "Will" seems not to be any special kind of response, but rather to refer to certain relationships in which a response may stand to other responses—but this is certainly too vague a definition to be of use.

"Will" is not precisely a psychological term, anyway, but is a term of common speech which need not refer to any psychological unit. In common speech it has various and conflicting meanings. "Since you urge me", one may say, "I *will* do this, though much against my *will*." Let the dictionary define such words. What psychology should do with them is simply to take them as a mining prospector takes an outcropping of ore: as an indication that it may pay to dig in the neighborhood.

VOLUNTARY AND INVOLUNTARY ACTION

About the first thing we strike when we start digging is the distinction between voluntary and involuntary. A man has committed homicide, and the question in court is whether he did it "with malice aforethought", i.e., with full will and intention, whether he did it in a sudden fit of anger, i.e., impulsively rather than quite voluntarily, or whether it was an accident and so wholly unintentional or involuntary. The court wishes to know, since a man who has committed one sort of homicide is a very different character from one who has committed another sort; different acts can be expected from him in the future and different precautions need to be taken accordingly.

It is a fact, then, that an act may be performed either with or without foreknowledge—a remarkable fact both ways! An intentional act is remarkable from the side of physics or chemistry or botany—which is to say that it is very exceptional in nature at large. On the other hand, a completely involuntary act is rather exceptional in human behavior and perhaps in animal behavior as well, for almost always there is some striving towards an end, some impulse. The simplest reflexes, to be sure, are completely involuntary. The pupillary reaction to light is not done with malice aforethought, cannot be so done. The lid reflex, or wink of the eye, occurs many times in the course of an hour, without foreknowledge, or after-knowledge for that matter, though the same movement can be made voluntarily. Sneezing and coughing are not voluntary in the full sense, but they are distinctly impulsive, they strive towards desired relief. To sneeze voluntarily is to sneeze when you don't want to, and to sneeze involuntarily is to sneeze when you want to—which seems queer, since we usually think of a voluntary act as one done to further our wishes. The solution of this puzzle is,

of course, that a voluntary sneeze is desired not because of a direct impulse but to gain some ulterior end, such as to prove we can do it, or for histrionic purposes—in short, for some purpose beyond the immediate satisfaction of an impulse.

Thus we may classify acts as wholly involuntary or mechanical, as impulsive, and as distinctly voluntary or purposive. Or, we may arrange acts in a scale from those that have no conscious end, through those aimed directly at an immediate end, up to those done to accomplish an ulterior end which is imagined beforehand. The last class of fully voluntary acts belongs under the general head of manipulation, just as imagination does. We *imagine some change* to be produced in the existing situation and then proceed to put our imagination into effect; and this is a typical voluntary act.

We seldom, however, picture a *complete* act in imagination before executing it. Even so simple an act as closing the fist cannot be completely pictured beforehand; for if you try to imagine how the closed fist is going to feel and then close it, you will find that you left out of your image many details of the actual kinesthetic sensations. What we imagine and intend is some change in the situation, and we then proceed to execute that change and other changes incidentally.

Besides the simple reflexes, there is another sort of involuntary and mechanical action. Through practice and repetition, an act may become so habitual as to be done automatically, that is, without being imagined beforehand, and even without conscious impulse. The practised typist responds in this way to the words he is copying. We should notice, however, that this does not mean that the total behavior and state of mind of the typist is mechanical and devoid of impulse. The typist may write the letters me-

chanically, and if expert may write even words in this way, but all the time he is consciously aiming to copy the passage. His attention and impulse have deserted the fully mastered details and attach themselves to the larger units. In the same way, in signing your name you have no conscious intention or impulse to write each successive letter; but you fully intend to sign your name.

DEVELOPMENT OF VOLUNTARY CONTROL

The child's actions are at first impulsive but not voluntary in the full sense, since obviously he cannot imagine and intend an act till he has had experience of that act, and he must usually have experienced doing the act himself before he can effectively imagine it. At least, this is true of the simpler movements; compound movements, made up of familiar elements, may be first observed in other persons and then voluntarily imitated. The child's process of acquiring voluntary control over a movement is illustrated by the story of how the baby learned to put his hand in his mouth. He first made this movement in the course of "aimless" throwing of his arms about, liked the sensation of the hand in the mouth, tried apparently to get it there again, and in the course of a few days was able to put it there at will. The child's "aimless" movements at the start were probably impulsive, but they were not directed towards any pre-conceived end. Then, having observed a desirable result of one movement, he worked towards that result by trial and error, till finally he had the necessary movement so closely linked to the thought of the result as to follow directly upon the thought.

Once brought under voluntary control, a movement becomes with further repetition habitual and mechanical, and no longer voluntary or even impulsive. Thus the voluntary

performance of an act intervenes between the native or instinctive doing of it and the later habitual doing of it. Blowing out a match affords another example of this course of events. A child can of course blow out, instinctively, when he has the natural stimulus for strong expiration, but he cannot at will blow at the lighted match. Being prompted and shown, he comes by degrees to be able to blow out the match; during the learning stage he has to try, and the act is voluntary; but with further practice it becomes involuntary, though it may still be executed as part of a larger voluntary act, such as preventing a burning match from setting fire to something on which it has fallen.

A complex act, or series of movements, may be voluntary as a whole, being directed towards some preconceived result, while the single movements that constitute the series are mechanical, their particular results no longer being thought of separately. This is well illustrated by the instances of typewriting, speaking, and signing the name, mentioned a moment ago. With practice, the interest in a performance goes more and more to the final result and deserts the elements of the act.

It is during the organization of reactions that they require attention and must be thought of before being executed. Organization goes on and on, a thoroughly organized reaction being later combined with others into a still bigger act. New demands constantly made upon the individual prevent him, however well organized, from ever reaching the condition of a wholly automatic machine. Will, in the sense of action aimed at the accomplishment of foreseen results, stays with him to the end.

IDEOMOTOR ACTION

Involuntary movement is not always "sensorimotor", which means directly aroused by a sensory stimulus; oftener

it is "ideomotor", or directly aroused by an idea or thought. It may be so aroused and still be involuntary. We think of a certain result and our muscles produce this result, though we did not really mean to do this act ourselves. The thought arouses the movement because it has previously been linked with the movement. A thought which has previously served as the stimulus to an act will tend to have this effect again, unless inhibited by some contrary stimulus. There is no need of a definite *consent* to the act, provided there is nothing present to inhibit it.

Good examples of ideomotor action can be observed among the audience at an athletic contest. You are watching one of your team do the pole vault, for instance, and are so much absorbed in his performance and so desirous for him to succeed that you identify yourself with him to a degree. He is rising to clear the high bar, and the thought of his clearing it, monopolizing your mind and leaving no room for the inhibitory thought that the performer is down there in the field and you up here in the stand, causes you to make an incipient leg movement as if you yourself were vaulting.

Voluntary action, in the fullest sense, occurs when you realize the situation and are definitely conscious of yourself, that is to say, when you differentiate yourself clearly out of the total situation, and not only imagine some change to be made, but think of that change as to be produced *by you*, without at the same time having any contrary thought to inhibit actual execution.

CONFLICT AND DECISION

It appears that in our "digging" we have now struck another vein, for here we have the fact of one tendency running contrary to another and inhibiting it. Conflict of desires and the consequent necessity of *choosing* between

them, is thus brought vividly to our attention. Every one would at once agree that "will" and "choice" belong closely together. The most distinctly voluntary acts occur when two alternatives are thought of, and one of them is chosen.

Organized as we are by nature, that is to say, on a large scale, but incompletely—enviored as we are, with multitudinous stimuli constantly playing on us and arousing contrary tendencies—we cannot hope to escape conflict of motives and the necessity of making decisions. Every decision made, every conflict resolved, is a step in the further organization of the individual. It may be a step in a good direction, or in a bad direction, but it is a step in organizing the individual's reaction-tendencies into what we call his *character*—the more or less organized sum total of his native and acquired tendencies to reaction, with emphasis on those reactions that affect his life and social relations in a broad way.

The lowest animals, having few reaction tendencies, and being responsive to only a narrow environment, show little sign of internal conflict, and when it does occur it is resolved very simply by the advantage going to one of the opposing tendencies, with perhaps a shift later to the other, in the way described in our earlier consideration of attention.¹ This type of decision is fundamental. In the behavior of higher animals, we sometimes detect signs of a longer-persisting conflict, as between curiosity and fear, when a wild creature seems poised between his inclination to approach and examine a strange object and his inclination to run away, veering now towards the one and now towards the other alternative, and unable, as it seems, to reach a decision.

Conflict between the enterprising tendency to explore, manipulate or somehow launch forth into the new, and the negative tendencies of fear, inertia, shyness, etc., is some-

¹ See p. 251.

thing that recurs again and again in human experience, as illustrated by making up your mind to get up in the morning, or to plunge into the cold water, or to speak up and have your say in a general conversation. There is a *hesitancy* in such cases, due to a positive and a negative tendency. The conflict may be resolved in favor of the negative tendency by simple prolongation of the hesitation till the occasion for action has passed, or it may be resolved in favor of the positive tendency when this is strong enough for an instant to enable the individual to commit himself to the enterprise, after which he usually stays committed. The positive motive must for an instant be stronger than the negative, in order to get action.

A somewhat different type of conflict, which may be called *vacillation*, occurs when two positive tendencies are aroused that are inconsistent with each other, so that gratification of the one entails renunciation of the other. Old Buridan's celebrated problem of the ass, placed equally distant from two equally attractive bundles of hay, and whether he would starve to death from the exact balance of the two opposing tendencies, is a sort of parable to fit this case. Probably the poor ass did not starve—unless he richly deserved his name—but he may conceivably have ended the very uncomfortable state of vacillation by running away altogether, as a human being, who is really more subject to vacillation than any other creature, is sometimes so much disturbed at having to decide between two invitations for the same day as to decline both, and go fishing. Vacillation is certainly a very unpleasant state of mind. We want action, or else we want peace, but vacillation gives us neither. In spite of its irksomeness, we seem sometimes almost powerless to end it, because as soon as we have about decided on the one alternative, what we shall miss by not choosing the other comes vividly to mind, and swings the pendulum its way.

However it comes about that a decision is reached, it usually is reached, and the curious fact then is that it usually sticks. A student may vacillate long between the apparently equal attractions of two colleges, but when he finally decides on one, the advantages of the other lose their hold on him. Now he is all for one and not at all for the other. Having identified himself with one college, he has completely altered the balance of attractions, his self-assertion now going wholly on the side of the chosen college, and even leading him to pick flaws in the other as if to reinforce his decision. In other words, he "rationalizes", justifies, and fortifies his decision, once he has reached it. Some people, indeed, are abnormally subject to vacillation and seem never to accept their own decisions as final, but normally there are strong influences tending to maintain a decision, once it is made: the unpleasantness of the state of vacillation and relief at having escaped from it; the satisfaction of having a definite course of action; and self-assertion, because *we* have decided, and now this course of action is *ours*. During vacillation, neither of the alternatives was identified with ourselves, but now we have decided and are not going to be so weak as to change. X is our college now and anything you say against it you say against us. Thus the person who has decided defends himself energetically against reopening the question.

The state of indecision and the state of decision seem thus fairly well understood, but the process of passing from the one to the other is often obscure. It differs from one case to another. In one case we find the rational process of deliberation, in which each alternative is weighed and the decision awarded to the one that promises best. This is essentially a work of imagination: you imagine that you have adopted the one alternative, and see how it suits you, then you do the same with the other alternative. You think each

alternative through to see how satisfactory it will be, balance one against the other, and choose accordingly. This is ideal, but often impracticable, since we have not the time for full deliberation, or since we cannot trust imagination to give us a correct picture, or since we have no common measure by aid of which to balance off different sorts of satisfaction. Even when practicable, the deliberate way of reaching a decision is likely to seem irksome, because of the delay involved and the natural propensity for impulsive action. Perhaps the most common process is a sort of partial deliberation, the two alternatives appealing to us by turns till at some moment one makes a strong enough appeal to secure action.

Sometimes there is a deadlock, and then we either give up deciding for the moment, and, sleeping over the matter, find when we next take it up that one alternative has lost its momentary attractiveness and the other has the field; or else, feeling the irksomeness and humiliation, almost, of being unable to make up our mind, we say, "Any decision is better than none; here goes, then; *this* is what I will do", so breaking the deadlock by what seems like an arbitrary toss-up.

At other times, without such a distinct "act of will", and without any observable change in the attractiveness of either alternative, we simply find, after awhile, that a decision has emerged, and that we now know what we are going to do. What has happened in us to bring about the decision we cannot see, but here we are with a decision made and perhaps with the act already performed. The two alternatives remain theoretically equal, but one has somehow got hold of us, while the other has lapsed.

Then there is the case where we "see the better, but follow the worse", or are in great danger of so doing. The "worse" is usually something that appeals to the "old

Adam" in us, something that strongly arouses a primitive instinctive response; while the "better" is a nobler, more dutiful, or more prudent course. The lower motive being the stronger, how can it ever be that the higher motive gets the decision? Well, the fight is not just a contest between these two. Other motives are drawn into the fray, the whole man is drawn in, and it is a question which *side* is the stronger. Fear of ridicule or criticism, sense of duty, self-respect, ambition, ideals of oneself, concern for the welfare of another person, loyalty to a social group, may be ranged on the side of the "weaker" motive and give it the advantage over the stronger.

What becomes of the rejected motives? If unimportant and superficial, they simply *lapse* into an inactive state and are gradually forgotten, perhaps recurring to mind once in a while with a faint tinge of regret, since after all we should have liked to gratify them. "As a boy, I wanted to be a sailor; well, I would rather like to try it for once." When a motive is deeply rooted in our nature, it cannot be so easily eliminated. Sometimes it is simply *deferred* and remains dormant, content to bide its time; "there will be time enough for that later on". Sometimes it is *disguised* and then gratified, as when an apparently courteous deed contains an element of spite. Sometimes it is afforded a *substitute gratification*, as when the boastful boy, after having his "conceit taken out of him" by his mates, boasts of his school, profession, town or country. This is often called "sublimation". Sometimes, though denied, it remains insistent, and "*defense mechanisms*" have to be devised to keep it down; the "sour grapes" mechanism is an example, which may be used not only when the "grapes" are physically out of reach but also when for any reason we decide to leave them alone.

The psychoanalytic school lays great stress on "sup-

pressed" desires, holding that they become *unconscious while still remaining active*, and that they find gratification symbolically in dreams, and at times break into waking life in a disturbing way.

The most adequate way of handling rejected motives is to *coördinate* them with other, accepted motives—to harness them into teams and put them to work. This cannot always be done; for example, if a young woman has two attractive suitors, she might find difficulty in harnessing them together, and will have to say good-by to one, at least. But when the boastful boy becomes a loyal and enthusiastic member of a school, his self-assertive motive is harnessed up with social motives into a very effective team. Probably a tendency can only be "sublimated" by being thus combined and coördinated with other strong tendencies.

These various ways of handling a rejected motive could be nicely illustrated from the case of the sex instinct. It so happens, partly because modern economic and educational conditions enforce a delay in marriage—and in part simply because there are so many attractive people in the world—that the cravings of sex must often be denied. What becomes of them? Of course the sex instinct is too deep-seated to be eradicated or permanently to lapse into a dormant state. But the fascination for particular individuals may so lapse or be forgotten. Certain people we remember, once in a while, with half-humorous and certainly not very poignant regret. Deferring the whole matter till the time is ripe works well with many a youth or maiden. Combined with social interests, the sex motive finds sublimated satisfaction in a great variety of amusements, as well as in business associations between the sexes. Introduce a nice young lady into an officeful of men, and the atmosphere changes, often for the better,—which means, certainly, that the sex motive of these men, combined with ordinary business mo-

tives, is finding a sublimated satisfaction. The sex motive thus enters into a great variety of human affairs. "Defense mechanisms" are common in combating unacceptable erotic impulses; the sour grapes mechanism sometimes takes the extreme form of a hatred of the other sex; but a very good and useful device of this general sort is to throw oneself into some quite different type of activity, as the young man may successfully work off his steam in athletics. This is not sublimation, in any proper use of that term, for athletic sport does not gratify the sex tendency in the least, but it gratifies other tendencies and so gratifies the individual. It is the individual that must be satisfied, rather than any specified one of his tendencies. As regards coördination, the fact was illustrated just above that this method would not always work; but sometimes it works immensely well. Here is a young person (either sex), in the twenties, with insistent sex impulses, tempted to yield to the fascination of some mediocre representative of the other sex. Such a low-level attachment, however, militates against self-respect, work, ambition, social sense. Where is the "coördination"? It has to be found; some worthy mate will harness all these tendencies, stimulating and gratifying sex attraction, self-respect, ambition, and others besides, and coördinating them all into the complex and decidedly high-grade sentiment of love.

OBSTRUCTION AND EFFORT

The term "will" is used to designate the response to external obstruction as well as the response to internal conflict. In fact, nothing is so characteristically "will" as the overcoming of resistance that checks progress towards a desired result. As "decision" is the response to internal conflict of tendencies, so "effort" is the response to external

resistance encountered in executing a desire that has been adopted. The obstruction may be purely physical, as the underbrush that impedes your progress through the woods; or it may be another person's will running counter to yours; or it may be of the nature of distraction of attention from the end in view.

The resistance may also be internal, and consist in your own lack of skill in executing your intentions, or in the disturbing effect of some desire which, though rejected, has not gone to sleep but still pulls you another way than the way you have decided to go.

In all these cases, the individual is moving towards a certain goal, but encounters obstruction; and his response is effort, or increased energy put into his movement towards the goal. So long as the tendency towards a goal finds smooth going, there is not the same determination that appears as soon as an obstruction is encountered. The "will", in common usage, will not brook resistance—the "indomitable will".

Now effort and determination, in our chapter on the native impulses, were put under the head of the assertive or masterful tendency; and it does seem that "will", in this sense, is almost the same thing as the instinct of self-assertion. Certainly, in the case of adults, an obstruction puts the individual "on his mettle", and superimposes the mastery motive upon whatever motive it may have been that originally prompted the action.

The mastery motive came clearly to light in an experiment designed to investigate "will action". The subject of the experiment was first given a long course of training in responding to certain stimulus words by other certain words that were constantly paired with them; and when his habits of response were thus well fixed, his task was changed so that now he must respond to any word or syllable by any

other that *rhymed* with it. A series of stimuli now began with words for which no specific response habit had been formed, and to these the subject reacted with no great difficulty. But then, unexpectedly, he got a stimulus word to which he had a fixed habit of response, and before he could catch himself he had made the habitual response, and so failed to give a rhyme as he had intended. This check sometimes made him really angry, and at least it brought him up to attention with a feeling which he expressed in the words, "I can and will do this thing". He was thus put on his guard, gave closer attention to what he was doing, and was usually able to overcome the counter tendency of habit and do what he meant to do. Some subjects, who adapted themselves readily and fully to the rhyming task, i.e., who got up a good "mental set" for this sort of reaction, made few errors and did not experience this feeling of effort and determination; for them the effort was unnecessary; but the average person needed the extra energy in order to overcome the resistances and accomplish his intentions.

Other good instances of effort are found in the overcoming of distraction, described under the head of attention,¹ and in the work of the beginner at any job. When the beginner has passed the first cautious, exploratory stage of learning, he begins to "put on steam". He pounds the typewriter, if that is what he is learning, spells the words aloud, and in other ways betrays the great effort he is making.

Ask a child just learning to write why he grasps the pencil so tightly, why he bends so closely over the desk, why he purses his lips, knits his brow, and twists his foot around the leg of his chair, and he might answer, very truly, that it is because he cannot do this job easily and has to *try hard*. All these unnecessary muscular movements and tensions

¹ See p. 259.

show the *access of energy* that has been liberated in his brain by the obstruction encountered.

Any learner, once he has mastered the difficulties of the task, reaches an easy-running stage in which effort is no longer required, unless for making a record or in some way surpassing himself. With reference to effort, then, we may speak of three stages of practice: the initial, exploratory stage, the awkward and effortful stage, and the skilled and free-running stage. These are identical with the three stages in the development of attention to a subject, which were described¹ as the stage of spontaneous attention or curiosity; the stage of forced attention, or effortful attention, controlled by such motives as fear or self-assertion; and the final stage of objective interest and absorption in the subject, which is evidently the same as the free-running condition.

Effort is not a good in itself; it is an unpleasant condition; but it is a natural response to difficulty and is often necessary in order to get the individual into the free-running condition which is both efficient and pleasant. It is often required to get the individual out of the easy-going condition into the free-running condition, which is something entirely different. In free-running action there may be even more energy expended than in effortful action, but it is better directed and produces no strains and jolts.

Intelligence, in the sense of adaptability and "seeing the point", may often take the place of effort. Consider the way two different people react to a sticking door: the one puts in more strength and forces it, the other by a deft thrust to the side opens it without much extra force. You can't say absolutely which mode of attack is better, for your stubborn one may waste his strength on an obstruction that really cannot be forced, while your clever one may waste his

¹ See p. 258.

time on a door that needs only a bit of a push. Persistence *plus* adaptability is what efficient activity demands.

THOUGHT AND ACTION

“Men of thought” and “men of action” are sometimes contrasted—which is hardly fair to either, since the great man of action must have the imagination to conceive a plan, and must know exactly what he is aiming to accomplish, while the great thinker must be persistent in thinking and must get into action by way of writing or somehow making his thoughts count in the world. But we do find men who are impatient of thought and want to get into action at once, even without knowing just what they are about, and other men who seem quite contented to think and plan, without any definite intention of ever putting their plans into execution. The former type, the impulsive individual, is not difficult to understand, his behavior fits in so well with the primitive trial-and-error sort of activity; but the mere thinker seems an anomaly, in view of the general psychological principle that thought tends toward motor action.

In accounting for the inactive thinker, we have to remember, first, that some inhibition of immediate action is often necessary, in order to have time to think the matter over; this prudent attitude becomes a habit with some individuals. Besides, there are the negative motives of fear, shyness and laziness that tend to deter from the actual execution of a plan. Hamlet’s “conscience” that makes “cowards of us all”, so that “the native hue of resolution is sicklied o’er with the pale cast of thought, and enterprises of great pith and moment . . . lose the name of action” turns out, if we look a few lines further back, to be the “dread of something” unknown, that “puzzles the will, and makes us rather bear those ills we have than fly to others that we know not of”.

✓ Fear—fear of unforeseen consequences, fear of committing ourselves, fear of ridicule—is one great inhibitor of action, > and inertia is another, since it is much less strenuous to sit in the armchair and plan than to get out and put the plan into effect. Besides this, some people who are good at planning come to take so much pride and satisfaction in the thinking part of an enterprise that they do not feel the need for action. Moreover, you can “plan” in a large way, without bothering about details, but once you start to execute your plan you encounter details and preliminaries which are apt to rob the enterprise of its zest. Here is where persistence and effort are needed.

Abulia—“no will”—is an abnormal degree of lack of zest for action. Along with it go timidity and lack of social force, proneness to rumination and daydreaming, and often a feeling of being compelled to perform useless acts, such as doing everything three times or continual washing of the hands. *Abulia* is not just a comfortable laziness, but is attended by a sense of humiliation and inferiority. It shows itself in excessive hesitation and vacillation and in failure to accomplish anything of consequence. Sometimes the subject expends much effort, but fails to direct the effort towards the execution of his purposes. Some authorities have ascribed *abulia* to inertia or “low mental tension”, some to an overdose of fear and caution, some to the paralyzing effect of suppressed desires still living in the “unconscious”. Mild degrees of it, such as are not uncommon, seem sometimes to be due to the hiatus that is bound to exist between the end one has in view and the means one must take to start towards that end. One has zest for reaching the goal, but not for the preliminaries.

An author, whose case was studied because he was accomplishing so little, was found to follow a daily program about as follows. He would get up in the morning full of confi-

dence that this was going to be a good day, with much progress made in his book. Before starting to write, however, he must first have his breakfast, and then a little fresh air, just to prepare himself for energetic work. On returning from his walk, he thought it best to rest for a few moments, and then one or two other little matters seemed to demand attention; by the time these were done, the morning was so far gone that there was no time for a really good effort, so he optimistically postponed the writing till the afternoon, when the same sort of thing happened, and the great performance had to be put over till the next day. This man did better under a regime prescribed by his medical adviser, who commanded him to write for two hours immediately after rising, and make this his day's work—no more and no less than two hours. The definiteness of this task prevented dawdling.

Other writers have noted a curious tendency to "fight shy" of the passage actually being written and let the thoughts move ahead and plan out the later passages. Sometimes it is necessary to trick yourself if you are to get anything done; you say, "I can't write this properly just now; I'll just sketch out a preliminary draft"—on which understanding you may be able to write, whereas you could not if you thought you were writing "for keeps"; but when you have got well started and warmed to the task, you may find your work good enough to keep, after all. Judging by these mild cases, abulia may be due partly to distaste for the details of actual performance, and partly to a dread of committing oneself to anything that has the stamp of finality.

SECURING ACTION

No chapter in psychology offers more in the way of practical applications than this chapter on the will—if we only

knew more on the subject! How to get action, either from yourself, or from others if you are responsible for their action, is a big practical problem. A few hints on the matter are suggested by what precedes.

How to get action from yourself—how to liberate your latent energies and accomplish what you are capable of accomplishing. A definite purpose is the first requirement; without that one merely drifts, with no persistency and no great energy. The goal should be something that appeals vitally to you, and something which you can attain; not too distant a goal; or, if the ultimate goal is distant, there must be mileposts along the way which you can take as more immediate goals; for a goal that can be reached by immediate action enlists more present effort. The student puts more energy into his study when the examination is close at hand; and, although this is regrettable, it reveals a fact in human nature that can be utilized in the management of yourself or others. A well defined and clearly visible goal is a much better energy-releaser than vague "good intentions".

The more clearly you can see and measure your approach towards the goal, the more action; thus it has been found in many different lines that the "practice curve method" of training gives quicker and better results than ordinary drill. In the practice curve¹ you have a picture of your progress; you are encouraged by seeing how far you have advanced, and stimulated to surpass your past record, and thus your immediate goal is made very definite. You cannot do so well when you simply "do your best" as when you set out to reach a certain level, high enough to tax your powers without being quite out of reach. You cannot jump so high in the empty air as you can to clear a bar; and, to secure your very best endeavor, the bar must not be so low

¹ See p. 321.

that you can clear it easily, nor so high that you cannot clear it at all.

The goal should be heartily adopted as *your* goal, which is to say that the self-assertive motive should be harnessed into service. The importance of this motive in securing action is seen in the strong effect of competition to arouse great activity. The runner cannot make as good speed when running "against time" as when competing directly, neck to neck, with other runners. Hence, to get full action from yourself, find worthy competitors. And for the same reason, accept responsibility. This puts you on your mettle. To shun competition and responsibility is characteristic of abulia. Other strong motives, such as the economic motive or the sex motive (seen in the energetic work of a young man whose goal is marriage to a certain young woman) can also be enlisted in many cases. But, for the best results, there should be, in addition to these extraneous motives, a genuine interest in the work itself.

Do not say, "I will try". Say, "I will do it". The time for trying, or effort, is when obstruction is actually encountered. You cannot really try then, unless you are already fully determined to reach the goal.

Getting action from other people is the business of parents, teachers, bosses, officers, and to some extent of every one who wishes to influence another. In war, the problem of "morale" is as important as the problem of equipment, and it was so recognized by all the armies engaged in the Great War. Each side sought to keep the morale of its own soldiers at a high level, and to depress the morale of the enemy. Good morale means more than willingness for duty; it means "pep", or positive zest for action. Some of the means used to promote morale were the following. The soldier must believe in the justness of his cause; that is, he must make victory his own goal, and be whole-

hearted in this resolve. He must believe in the coming success of his side. He must be brought to attach himself firmly to the social group of which he forms a part. He must be so absorbed in the activities of this group as to forget, in large measure, his own private concerns. Not only must he be enthusiastic for cause and country, but he must be strong for his division, regiment and company. Much depends on the officers that directly command him. He must have confidence in them, see that they know their business, and that they are looking out for the welfare of their men as well as expecting much from them. Competition between companies, regiments, and arms of the service was a strong force tending towards rapid progress in training and good service in the field. Interest in the actual technical work that was being done, and seeing that one's immediate group was accomplishing something towards the winning of the war was a powerful spur, while a sense of the uselessness of the work in hand strongly depressed the morale of a group. "Nothing succeeds like success"; morale was at its best when the army was advancing and seemingly nearing the goal. Morale was also wonderfully good when the enemy was advancing, provided your side was holding well with a good prospect of bringing the enemy to a halt and baffling his offensive. On the other hand, nothing was so hard on morale as the failure of an ambitious offensive of one's own side; the sense of futility and hopelessness then reached its maximum—except, of course, for the case of obviously approaching defeat. The conditions of trench warfare imposed a strain on morale: no progress, in spite of the danger and hardship, no chance to get at the enemy or do anything positive.

The manager of an industrial enterprise has the same problem of morale to meet. It is his business to get action from people who come into the enterprise as servants. The

main difficulty with the master-servant relation is that the servant has so little play for his own self-assertion. The master sets the goal, and the servant has submissively to accept it. This is not his enterprise, and therefore he is likely to show little "pep" in his work. He can be driven to a certain extent by fear and economic want; but better results, and the best social condition generally, can be expected from such management as enlists the individual's own will. He must be made to feel that the enterprise is his, after all. He must feel that he is fairly treated, and that he receives a just share of the proceeds. He must be interested in the purposes of the concern and in the operations on which he is engaged. Best of all, perhaps, some responsibility and initiative must be delegated to him. When the master, not contented with setting the main goal, insists on bossing every detail, continually interfering in the servant's work, the servant has the least possible chance of adopting the job as *his own*. But where the master is able, in the first place, to show the servant the objective need and value of the goal, and to leave the initiative in respect to ways and means to the servant, looking to him for results, the servant often responds by throwing himself into the enterprise as if it were his own—as, indeed, it properly is in such a case.

"Initiative"—that high-grade trait that is so much in demand—seems to be partly a matter of imagination and partly of will. It demands inventiveness in seeing what can be done, zest for action, and an independent and masterful spirit.

The physician who treats "nervous" or neurotic cases has this problem of getting action from his patients. Strange as it may seem, these cases, while bemoaning their unfortunate condition, cling to it as if it had its compensations, and do not wholeheartedly *will to get well*. They have

slumped into the attitude of invalidism, and need re-orientation towards the goal of health and accomplishment. How to bring this about is the great problem. Much depends here on the personality of the physician, and different physicians (as well as mental healers outside the medical profession) employ different technique with more or less of success. The first necessity is to win the patient's confidence; after that, some use persuasion, some suggestion, some psychoanalysis, some (non-medical practitioners) use metaphysical doctrines designed to lead the patient to "hitch his wagon to a star". On the intellectual side, these methods agree in giving the patient a new perspective, in which weakness, ill health and maladaptation are seen to be small, insignificant and unnecessary, and health and achievement desirable and according to the nature of things; while on the side of impulse they probably come together in appealing to the masterful and self-assertive tendency, either by putting the subject on his mettle, or by leading him to partake of the determined, masterful attitude of the physician, or by making him feel that he is one with the great forces of the universe. Methods that psychologically are very similar to these are employed by the clergyman in dealing with morally flabby or maladjusted individuals; and the courts are beginning to approach the delinquent from the same angle. All the facts seem to indicate that the way to get action is to have a goal that "fires the imagination" and enlists the masterful tendencies of human nature.

THE INFLUENCE OF SUGGESTION

Can the will of one person be controlled by that of another, through hypnotism or any similar practice? This question is often asked anxiously by those who fear that crime or misconduct willed by one person may be passively executed by another.

Hypnosis is a sleeplike and passive state that is nevertheless attentive and concentrated. It appears as if the subject were awake at just one point, namely at the point of relation with the hypnotizer. To stimuli from other sources, external or internal, he is inaccessible. His field of activity is narrowed down to a point, though at that point he may be intensely active.

The depth of the hypnotic state varies from shallow to profound. Comparatively few individuals can be deeply hypnotized, but many can be got into a mild receptive state, in which they accept the suggestions of the hypnotizer more readily than in the fully awaking state. The waking person is alert, suspicious, assertive, while the hypnotized subject is passive and submissive. The subject's coöperation is necessary, in general, in order to bring on the hypnotic state, whether shallow or deep.

The means of inducing hypnosis are many and varied, but they all consist in shoving aside extraneous thoughts and stimuli, and getting the subject into a quiet, receptive attitude, with attention sharply focussed upon the operator.

When the subject is in this state, the "suggestions" of the operator are accepted with less criticism and resistance than in the fully waking state. In deep hypnosis, gross illusions and even hallucinations can be produced. The operator hands the subject a bottle of ammonia, with the assurance that it is the perfume of roses, and the subject smells of it with every appearance of enjoyment. The operator points to what he says is a statue of Apollo in the corner, and the subject apparently sees one there.

Loss of sensation can also be suggested and accepted. Being assured that his hand has lost its sensation and cannot feel a pin prick, the subject allows his hand to be pricked with no sign of pain. Paralysis of the arm or leg can be similarly suggested and accepted.

Acts may be suggested and performed. The subject is handed a cardboard sword with the assurance that that is a sword, and directed to attack some person present, which he does with the appearance of serious intent.

Now, however, let the subject be given a real sword with the same command as before. Result—the subject wakes up! This suggestion was too much; it aroused dormant tendencies, broadened out the field of activity, and so produced the waking condition. A suggestion that runs counter to the subject's organized character and tendencies cannot get by without arousing them and so awakening the subject. Consequently, there does not seem to be much real danger of crimes being performed by innocent persons under hypnosis.

In mild hypnosis, the above striking phenomena are not produced, but suggestions of curative value may be conveyed, and so taken to heart that they produce real results. The drowsy state of a child just falling to sleep can be similarly utilized for implanting suggestions of value. One little boy had a nervous twitching of the face that was very annoying. His father, just as the child was dropping off to sleep, conveyed the suggestion that the child didn't like this twitching; and this suggestion, repeated night after night, in a few days caused the twitching almost wholly to disappear.

Suggestion often succeeds in a waking state. In a certain test for "suggestibility", the task is set of copying a series of lines. The first line is short, the second longer, the third longer still, the rest all of the same length, but the more suggestible individual keeps on making each succeeding line longer. There are, however, various tests for suggestibility, and an individual who succumbs to one does not necessarily succumb to another, so that it may be doubted whether we should baldly speak of one individual as more suggestible than another.

Suggestion may be exerted by a person, or by the circumstances. If by a person, the more "prestige" he enjoys in the estimation of the subject, the greater his power of suggestion. A prestige person is one to whom you are submissive. A child is so dependent on older people, and so much accustomed to "being told", that he is specially susceptible to prestige suggestion.

Suggestion exerted by the circumstances is about the same as what is often called "auto-suggestion" or "self-suggestion". A man falls and hurts his hip, and, finding his leg difficult to move, conceives that it is paralyzed, and may continue paralyzed for some time.

"Counter-suggestion" applies to cases where a suggestion produces the result contrary to what is suggested. You suggest to a person that he should do a certain thing, and immediately he is set against that act, though, left to himself, he would have performed it. Or, you advance a certain opinion and at once your hearer takes the other side of the question. Quite often skilful counter-suggestion can secure action, from children or adults, which could not be had by positive suggestion or direct command.

If suggestion succeeds by arousing the submissive tendency, counter-suggestion succeeds by arousing the assertive tendency. Suggestion works when it gets response without awakening the resistance which might be expected, and counter-suggestion when it arouses so much resistance that the suggestion itself does not have the influence which might be expected. In terms of stimulus and response, suggestion works when a particular stimulus (what is suggested) arouses response without other stimuli being able to contribute to the response; and counter-suggestion works when a stimulus (what is suggested, again) is itself prevented from contributing to the response. In counter-suggestion, response to the suggestion itself is inhibited, and in positive

suggestion response to other stimuli is inhibited. Both involve narrowness of response, and are opposed to what we commonly speak of as "good judgment", the taking of all relevant stimuli into account, and letting the response be aroused by the combination.

EXERCISES

1. Outline the chapter.
2. Which of the previous chapters have the closest contacts with the present chapter?
3. How does the popular conception of hypnotism differ from the scientific?
4. List 8 acts performed during the day, and arrange them in order from the most involuntary to the most voluntary.
5. Analyze a complex performance so as to show what in it is voluntary and what involuntary.
6. Mention an instance of practice changing a voluntary performance into an involuntary, and one of practice changing an involuntary performance into a voluntary.
7. If an individual is influenced by two opposing motives, must he act according to the stronger of the two?
8. Illustrate, in the case of anger, several ways of dealing with a rejected motive. I.e., in what different ways can anger be controlled?
9. How would you represent purpose in neural terms? How does it compare with "mental set"?

REFERENCES

On the importance of self-assertion (and of submission) in will, and on the relation of conduct to impulse and to reasoning, see McDougall's *Social Psychology*, Chapter IX, on "Volition", and Supplementary Chapter I, on "Theories of Action".

For a practical study of the question how to secure action, see Walter Dill Scott's *Increasing Human Efficiency in Business*, 1911.

On hypnotism, see Albert Moll's *Hypnotism*, translated by A. F. Hopkirk; or James's Chapter XXVII in his *Principles of Psychology*, 1890.

CHAPTER XXI

PERSONALITY

THE INDIVIDUAL AS A WHOLE, INTEGRATED OR PARTIALLY DISSOCIATED

People differ not only in intelligence and efficiency, but in an intangible something referred to as "personality". If your acquaintance is applying for a certain position, and has named you as one of his references, you will be asked by the appointing officer to tell what you know of the candidate's experience, his knowledge and skill in the field where he desires a position, his character and habits, and his *personality*; and in replying you state, if you conscientiously can, that the candidate has a pleasing and forceful personality, that he gets on well with superiors, equals and inferiors, is coöperative, energetic, ambitious without being selfish, clean, modest, brave, self-reliant, cheerful, optimistic, equal-tempered; and you perhaps include here traits that might also be classed under the head of "character", as honesty, truthfulness, industry, reliability, and traits that might be classed under physique, as good appearance and carriage, commanding presence, a "strong face", and even neatness and good taste in dress. Here we have an array of traits that are of great importance to the individual's success in his work, in his social relationships and in his family life; and it is a proof of how much remains to be accomplished in psychology that we cannot as yet present anything like a real scientific analysis of personality, nor show on what elementary factors it depends.

FACTORS IN PERSONALITY

If we do attempt some sort of analysis, we have first to notice that personality depends in part on *physique*. In ordinary life, mental and physical traits are not sharply distinguished, and probably they cannot be distinguished except in the abstract. The mere size of a person affects his attitude towards other people and their attitude towards him—and it is in such social relations that personality most clearly stands out. His size affects the individual's behavior in subtle ways, since the big fellow dominates others easily just by virtue of his size, and so tends to be good-humored, while the little fellow is apt to be strenuous and self-assertive. Muscular development and "looks" also have their effect on personality.

Another factor might, by a sort of play on words, be called *chemique*. This corresponds to what is often called *temperament*, a very obscure matter psychologically. We speak of one as having an excitable temperament, a jovial or a sour temperament. "Disposition" is another word used in connection with such traits. The ancients attempted to relate the "four temperaments" to the four great "humors" or fluids of the body. Thus the "sanguine" individual was one with a surplus of blood, the "choleric" had a surplus of bile, the "phlegmatic" a surplus of phlegm, and the "melancholic" a surplus of black bile or spleen; and any individual's temperament resulted from the balance of these four. Sometimes a fifth temperament, the nervous, was admitted, dependent on the "nerve fluid".

This particular chemical derivation of temperament is, of course, out of date, being based on very imperfect knowledge of physiology; but it still remains possible that chemical substances carried around in the body fluids have much to do with the sort of trait that we think of under

the head of temperament. Only that to-day, with some knowledge regarding the internal secretions of the "endocrine glands", we should be inclined to connect temperament with them, rather than with blood, bile, etc. Take, for example, the secretion of the adrenal glands, that we found to be poured out during fear and anger and to have so much to do with the bodily condition of readiness for violent action and probably also with the "stirred-up" emotional state. What is more likely than that individuals differ in the strength of their adrenal secretion or in the readiness with which the glands are aroused to pour it out into the circulation? The excitable individual might be one with over-active adrenals. And in the same way the strenuous individual might be one with an unusually active thyroid gland, since there certainly seems to be some connection between this gland and the tendency to great activity. There are several other glands that possibly affect behavior in somewhat similar ways, so that it is not improbable, though still rather hypothetical, that chemical substances, produced in these glands, and carried by the blood to the brain and muscles, have much to do with the elusive traits that we class under temperament and personality.

Once more, consider the *instincts* in relation to personality. Undoubtedly these instinctive tendencies differ in strength in different individuals. One is more *gregarious* than another, and this is an important element in his personality. One is more assertive and masterful than another, one is more "motherly" than another, more responsive by tender and protective behavior to the presence of children or others who need help. One is more prone to laugh than another, and the "sense of humor" is admitted to be an important element in personality. And so on through the list; so that personality can be partially analyzed in terms of instinct.

Has *intelligence* anything to do with personality? It certainly has, in many ways. One who is slow in learning adapts himself poorly to other persons and remains out of touch with his social environment. "Tact" depends partly on instinctive liking for society, no doubt, but partly on the ability to perceive what others want, and on the imagination to put yourself in their place. High principles require the ability to reason things out and see them in perspective. Statistical studies of the rulers of Europe, for a period of several centuries, show that on the whole those with higher intelligence were also of better character and personality. Criminals, taken as a whole, average rather low in intelligence; and it may even be doubted whether the clever, scheming rascal, who defrauds widows of their money, or trains feeble-minded boys to pick pockets for him, has, after all, the brains of the man who can easily see how such schemes could be worked but decides against them himself because he sees something better worth doing.

A sense of inferiority, either physical or mental, is apt to affect the personality unfavorably. It does not necessarily produce humble behavior; far from that, it often leads to a nervous assertiveness. An apparently disdainful individual is often really shy and unsure of himself. Put a man where he can see he is equal to his job and at the same time is accomplishing something worth while, and you often see considerable improvement in his personality.

THE SELF

In a broad, objective sense, the self is the individual, but in a more subjective sense the self is what the individual knows about himself, how he conceives himself, how he feels about himself, what he plans and wishes for himself. It is reasonable to suppose that the newly born infant does not

distinguish himself from other objects. Perhaps his foot, as he sees it, seems simply an object among others, like a toy; but he soon learns to connect the visual appearance with the cutaneous and kinesthetic sensations from the foot, and these sensations, along with the organic, always retain in large measure the subjective quality of belonging to the self, whereas sights, sounds, odors and tastes seem to belong to objects distinct from the self.

If we ask how the child comes to make the distinction between the self and the not-self, we have to call to mind the assertiveness that manifests itself very early in the child's behavior—how he resists being pushed and pulled about, struggles against being held, and in many ways, more and more complex as he develops, shows that he has a "will of his own". It is in resisting and overcoming external things that he comes to distinguish himself from them.

Not only external things, but other *persons* particularly, have to be encountered and resisted by the child; and often, too, he has to submit to them, after a struggle. Probably he distinguishes between himself and other people even more sharply than between himself and inanimate things. Ask any one to tell you what he knows about himself, and he will begin to tell you how he differs from others. Thus the individual's conception of himself is largely a product of his social experience.

The self is first known as wish or will, and probably that always remains the core of any one's conception of himself. That is to say, I think of myself first of all as wishing, aiming, purposing, resisting, striving, competing. But I may come to know myself more objectively. By dint of experience I know something of my limitations. I know I am not muscular enough to do this, nor mathematical enough to do that, nor artistic enough to do the other. In this progressive age, some children even know their own IQ. We

have frequent occasion to measure ourselves against others, or against tasks, and lay some of the lessons to heart. Though most of us are probably inclined to overrate ourselves, many will be found to give a pretty exact estimate of themselves. It is surprising that this should be so, in view of the tendency to believe what one wishes, and of the deep-seated desire for superiority or at least against inferiority. It shows that, after all, there is a good deal of fidelity to fact in our make-up.

The word "self-assertion", which has been used more or less throughout the book as a name for the native tendency to resist, persist, master, dominate, display oneself and seek social recognition, can now be seen to be not entirely a good word for the purpose. It seems to imply that the self-assertive individual is necessarily conscious of the self. From what has just been said, it can be seen that this would be putting the cart before the horse. The self-assertive impulse precedes, consciousness of self follows and depends on self-assertion. A true estimate of oneself and one's limitations arises from self-assertion plus experience of failure and the necessity of giving up and submitting.

Self-assertion is not identical with selfishness. Selfishness aims to get, self-assertion to do. Selfish behavior is, however, often dictated by self-assertion, as when a person wishes to get and have, in order to be able to show by his possessions what a great man he is. But sometimes self-assertion squelches selfishness, leading a person to renounce present gain without hope of later gain in compensation, just because he sees in such renunciation the best chance for mastery and proving himself "the captain of his soul".

The "expansion of the self" is an interesting and significant phenomenon. The individual comes to call things, persons, social groups, ideas and principles by the name

“mine”. Now what is mine is part of me. My self-feeling attaches to my dog; I am proud of that dog, brag of his exploits, am cast down if I see him outclassed; and it is the same way with my house, my son, my town, my country. We spoke of this sort of thing before, under the name of “sublimation of the self-assertive impulse”, and we said then that the sublimation was made possible by the combination of this impulse with some other interest. My dog is not entirely myself; he is a dog, and I am interested in him as a dog; I am interested in other dogs, and like to watch their antics. But this particular dog means more than another to me because he is mine; I have expanded myself to include him. In general, the self is expanded to take in objects that are interesting in themselves, but which become doubly interesting by being appropriated and identified in some measure with oneself.

INTEGRATION AND DISINTEGRATION OF THE PERSONALITY

Though the individual is always in one sense a unit, there is a sense in which he needs to achieve unity. His various native tendencies and interests do not always pull together, and in fact some necessarily pull against others. So that we sometimes say of a person that he is behaving so differently from usual that we should not know he was the same person. We may speak of one person as being well integrated, meaning that he is always himself, his various tendencies being so coördinated as to work reasonably well together; whereas of another we speak as poorly integrated, unstable, an uncertain quantity. Integration is achieved partly by selection from among conflicting impulses, partly by coördination, partly by judicious treatment of those impulses that are denied; as was partly explained in the last chapter.

The self, expanding socially, may expand in more than one direction, with the result that the individual has in a sense two or more selves, one for his business, one for his home; and it may happen that the instincts and interests dominating the individual in these two relations are quite different, so that a man who is hard and grasping in business is kind and generous to his wife and children. "Dr. Jekyll and Mr. Hyde" gives an extreme picture of such lack of integration, a picture rather fanciful than drawn from real life.

But we do find in real life cases of *dissociation* of the personality, also called cases of double or multiple personality. The individual passes from one state to another, behaving very differently in the two states, and usually unable to remember in the primary or more lasting state what he has done in the secondary state. In the secondary state he remembers what he did in the primary state, but is apt to speak of it as if done by another person. In many cases, the primary state seems limited and hampered, as if the individual were not his complete self, while the secondary state is a sort of complement to the first, but decidedly imperfect in itself. Thus in the primary state the individual may be excessively quiet, while in the secondary state he is excessively mischievous. It is much as if some of his reaction-tendencies were forcibly kept apart from the rest, so that when they did become aroused to activity, the remainder of the individual went to sleep. The individual seems to function in fractions, and never as a whole.

Often the secondary state likes to have a name for itself and to be considered as a secondary personality, as if two persons were inhabiting the same body—a very forced conception. The secondary personality will even assert that it stays awake in the background and watches the primary personality when the latter is active, spying on it without

that personality being aware of it. Thus two fractions of the individual would be functioning at the same time, but still not working together as a unit.

This claim of the secondary personality has been experimentally checked up by Dr. Morton Prince, in the following way. He was able to cause his subject, a young woman, to pass from the primary to the secondary state and back again, by a procedure resembling hypnotism. While she was in the secondary state, he told her that she (the secondary personality) was to solve an arithmetical problem, the general nature of which he described to her then and there, while the actual numbers were not shown till she was put back in the primary state. He then put her into the primary state for a few moments, and placed the numbers unobtrusively before her, without the primary personality seeming to notice them. Put back now into the secondary state, she instantly shouted out the answer to the problem, and asserted that she (the secondary personality) had had the answer ready for some time, and had been impatiently waiting to be brought back and announce it. This is at least *prima facie* evidence in favor of Dr. Prince's view, that two separate fractions of the individual were both functioning consciously at the same time.

It is weird business, however interpreted, and raises the question whether anything of the same sort, only milder in degree, occurs in ordinary experience. Here is one somewhat similar fact that we are all familiar with: we have two matters in hand at the same time, very different in their emotional tone, one perhaps a worrisome matter of business, the other an interesting personal matter; and the shift from one to the other feels almost like changing personalities. Also, while busy with one, we may sometimes feel the other stirring, just barely awake and dimly conscious.

Also, is not something like this true?— A person, very

conscientious in the performance of his duties, always doing what he is told, feels stirrings of a carefree, independent spirit, as if some sides of his nature were not finding expression, and in little ways he gives it expression, not exactly by taking a "moral holiday"¹ or going on a spree of some sort, but by venting his impulses just an instant at a time, so that he scarcely remembers it later, and in such little ways that other people, also, are scarcely aware of it. He has a "secondary personality", only it is little developed, and it has its little place in the conscious life, instead of being dissociated.

In the cases of true dissociation, there was often a violent emotional shock that started the cleavage. One celebrated case started at 3 years of age, when the subject, a little girl, was thrown to the floor by a drunken father angered by finding the child asleep in his bed. From that moment, it would seem that the frolicsome side of childish behavior was banished from the main personality, and could get into action only when the main personality relaxed its control and became dormant; so that thereafter the child alternated between two states, one very quiet, industrious and conscientious, the other vivacious and mischievous; and the main personality never remembered what was done in this secondary, mischievous state. In such cases, it would appear that the cleavage resulted from a violent thrusting out from the main personality of tendencies inconsistent with the dominant (here serious) attitude of that personality.

THE UNCONSCIOUS, OR, THE SUBCONSCIOUS MIND

Here at last, it may strike the reader, we have come to the core of the whole subject of psychology; for many readers will undoubtedly have been attracted by the statements

¹ This is one of William James's expressive phrases.

sometimes made, to the effect that the "unconscious" represents the deeper and more significant part of mental life, and that psychologists who confine their attention mostly to the conscious activities are treating their subject in a very partial and superficial manner. There is a sort of fascination about the notion of a subconscious mind, and yet it will be noticed that psychologists, as a rule, are inclined to be wary and critical in dealing with it. Let us take up in order the various sorts of unconscious mental processes.

In the first place, *retention is unconscious*. The host of memories that a person possesses and can recall under suitable conditions is carried about with him in an unconscious condition. But there need be no special mystery about this, nor is it just to speak about memories being "preserved in the unconscious". The fact simply is that retention is a resting condition, whereas consciousness is an active condition. Retention is a matter of brain structure, neurone connections, neural mechanisms ready for action when the proper stimulus reaches them but remaining inactive till the stimulus comes. An idea is like a motor reaction, to the extent that it is a reaction; and we retain ideas in the same way that we retain learned motor reactions. Now no one would think of saying that a learned motor reaction was retained in the unconscious. The motor reaction is not present at all, until it is aroused; the neuromuscular mechanism for executing the reaction is present, but needs a stimulus to make it active and give the reaction. In the same way, an idea is not present in the individual except when it is activated, but its neural mechanism is present, and unconscious just because it is inactive.

Unconscious inactivity is therefore no great problem. But there is such a thing as *unconscious activity*. Two sorts of such activity are well known. First, there are the

purely "physiological" processes of digestion, liver and kidney secretion, etc. We are quite reconciled to these being unconscious, and this is not the sort of unconscious activity that gives us that fascinatingly uncanny feeling. Second, there are the "secondarily automatic" processes, once conscious, now almost or quite unconscious through the effect of frequent repetition.

Such unconscious activities occur as *side-activities*, carried on while something else occupies attention, or as *part-activities* that go on while attention is directed to the total performance of which they are parts. In either case, the automatism may be motor or perceptive, and the degree of consciousness may range from moderate down to zero.¹

For example, the letters of your name you write almost unconsciously, while fully conscious of writing your name. When you are reading, the letters are only dimly conscious, and even the words are only moderately conscious, while the whole performance of reading is highly conscious. These are instances of unconscious (or dimly conscious) part-activities. Unconscious side-activities are illustrated by holding your books firmly but unconsciously under your arm, while absorbed in conversation, by drumming with your fingers while puzzling over a problem, and by looking at your watch and reading the time, but so nearly unconsciously that the next instant you have to look again. In all such cases, the unconscious or barely conscious activity has been made easy by previous practice, and there is no special fascination about it, except such as comes through the use of that awesome word, "unconscious".

But now for the real "subconscious mind". You try to recall a familiar name, but are stuck; you drop the matter, and "let your subconscious mind work"; and, sure enough, after a few minutes you have the name. Or, you are all

¹ See pp. 265-267.

tangled up in a difficult problem; you let the subconscious mind work on it overnight, and next morning it is perfectly clear. Just here it is that psychology begins to take issue with the popular idea. The popular interpretation is that work has been done on the problem during the interval when it was out of consciousness—unconscious mental work of a high order. But is it necessary to suppose that any work has been done on the problem during the interval?

The difficulty, when you first attacked the problem, arose from false clues which, once they got you, held you by virtue of their "recency value".¹ The matter laid aside, these false clues lost their recency value with lapse of time, so that when you took the matter up again you were free from their interference and had a good chance to go straight towards the goal.

It is the same with motor acts. On a certain day, a baseball pitcher falls into an inefficient way of handling the ball, and, try as he may, cannot recover his usual form. He has to give up for that day, but after a rest is as good as ever. Shall we say that his subconscious mind has been practising pitching during the rest interval? It is much more likely that here, as in the preceding case, the value of a fresh start lies in freshness, in rest and the consequent disappearance of interferences, rather than in any work that has been done during the interval of rest.

Next, consider the "co-conscious", as Morton Prince has well named the presence and activity of the secondary personality along with the primary, as in his experiment described above. Here it seems that two streams of consciousness were flowing along side by side within the same individual. There is the activity of the main personality, and there is the activity of the secondary personality, going on at the same time without the knowledge of the main person-

¹ See pp. 390-391.

ality. This is a way of reading the facts, rather than a simple statement of fact, but at least it is a reasonable interpretation, and worthy of consideration.

UNCONSCIOUS WISHES AND MOTIVES

Schopenhauer wrote much of the "will to live", which was, in his view, as unconscious as it was fundamental, and only secondarily gave rise to the conscious life of sensations and ideas. Bergson's "élan vital" has much the same meaning. In a sense, the will to live is the fountain of all our wishes; in another sense, it is the sum total of them all; and in another sense, it is an abstraction, the concrete facts consisting in the various particular wishes and tendencies of living creatures. The will to live is not simply the will to stay alive; it is the will to *live*, with all that that includes. Life is activity, and to live means, for any species, to engage in the full activity possible for that species.

The will to live is in a sense unconscious, since it is seldom present simply in that bald, abstract form. But since life is activity, any will to act is the will to live in a special form, so that we may perfectly well say that the will to live is always conscious whenever there is any conscious impulse or purpose.

In this simple statement we may find the key to all unconscious motives, disregarding the case of dissociation and split personality. If you analyze your motives for doing a certain act and formulate them in good set terms, then you have to admit that this motive was unconscious before, or only dimly conscious, since it was not formulated, it was not isolated, it was not present in the precise form you have now given it. Yet it was there, implicated in the total conscious activity. It was not unconscious in the sense of being active in a different, unconscious realm. The realm in which it was active was that of conscious activity, and it formed an

unanalyzed part of that activity. It was there in the same way that overtones are present in perceiving the tone quality of a particular instrument; the overtones are not *separately* heard and may be very difficult to analyze, yet all the time they are playing an important part in the conscious perception.

In the same way, we may not "realize" that we are helping our friend as a way of dominating over him, but think, so far as we stop to think, that our motive is pure helpfulness. Later, analyzing our motives, we may separate out the masterful tendency, which was present all the time and consciously present, but so bound up with the other motive of helpfulness that it did not attract attention to itself. Now if our psychology makes us cynics, and leads us to ascribe the whole motivation of the helpful act to the mastery impulse, and therefore to regard this as working in the unconscious, we are fully as far from the truth as when we uncritically assumed that helpfulness was the only motive operating.

For man, to live means a vast range of activity—more than can possibly be performed by any single individual. We wish to do a thousand things that we never can do. We are constantly forced to limit the field of our activity. Physical incapacity, mental incapacity, limitations of our environment, conflict between one wish and another of our own, opposition from other people, and mere lack of time, compel us to give up many of our wishes. Innumerable wishes must be laid aside, and some, resisting, have to be forcibly suppressed. Renunciation is the order of the day, from childhood up to the age when weakness and weariness supervene upon the zest for action, and the will to live fades out into readiness to die.

What becomes of the suppressed wishes, we have already briefly considered.¹ We have noticed Freud's conception

¹ See p. 533.

that they live on "in the unconscious". Nothing ever learned, he would say, can ever be forgotten, and no wish ever aroused can ever be quieted, except by being gratified either directly or through some substitute response. Each one of us, according to this view, carries around inside of him enough explosive material to blow to bits the whole social structure in which he lives. It is the suppressed sex wishes, and spite wishes growing out of thwarted sex wishes, that mostly constitute the unconscious.

These unconscious wishes, according to Freud, motivate our dreams, our queer and apparently accidental actions, such as slips of the tongue and other "mistakes", the yet queerer and much more serious "neurotic symptoms" that appear in some people, and even a vast deal of our serious endeavor in life. All the great springs of action are sought in the unconscious. The biologist, consciously, is driven by his desire to know the world of plants and animals, but what really motivates him, on this view, is his childish sex curiosity, thwarted, driven back upon itself, and finding a substitute outlet in biological study. And so, in one way or another, with every one of us.

All this seems to depart pretty far from sober reality, and especially from proved fact. It involves a very forced interpretation of child life, an interpretation that could never have arisen from a direct study of children, but which has seemed useful in the psychoanalysis of maladjusted adults. It is a far cry from the facts that Freud seeks to explain, to the conception of the infantile unconscious with which he endeavors to explain them.

Freud's conception of life and its tendencies is much too narrow. There is not half enough room in his scheme of things for life as it is willed and lived. There is not room in it even for all the instincts, nor for the "native likes and dislikes"; and there is still less room for the will to live, in

the sense of the zest for all forms of activity, each for its own sake as a form of vital activity. Any scheme of motivation, which traces all behavior back to a few formulated wishes, is much too abstract, as was illustrated just above in the case of the helpful act.

Freud is apparently guilty of yet another error, in supposing that any specific wish, ungratified, lives on as the same, identical, precise wish. A very simple instance will make clear the point of this criticism. Suppose that the first time you definitely mastered the fact that "3 times 7 are 21", it was in a certain schoolroom, with a certain teacher and a certain group of schoolfellows. You were perhaps animated at that moment by the desire to secure the approval of that teacher and to shine before those schoolfellows. Does it follow, then, that every time you now make use of that bit of the multiplication table, you are "unconsciously" gratifying that wish of long ago? To believe that would be to neglect all that we have learned of "shortcircuiting" and of the "substitute stimulus" generally.¹ That wish of long ago played its part in linking the response to the stimulus, but the linkage became so close that that precise wish was no longer required. The same response has been made a thousand times since, with other wishes in the game, and when the response is made to-day, a new wish is in the game. It is the same with the biologist. Suppose, for the sake of argument, what probably is true in only a fraction of the cases, that the biologist's first interest in making any minute study of animals arose from sex curiosity. As soon, however, as he engaged in any real study of animals, substitute stimuli entered and got attached to his exploring responses; and to suppose that that identical wish of long ago is still subconsciously active, whenever the biologist takes his microscope in hand, is to throw out all

¹ See p. 338.

these substitute stimuli and their attachments to many new responses, and to see in a very complex activity only one little element.

In making use of the conception of the unconscious to assist us in interpreting human conduct, we are thus exposed to two errors. First, finding a motive which was not analyzed out by the individual, and which was only vaguely and implicitly conscious, and formulating that motive in an explicit way, we are then liable to the error of supposing that the motive must have been explicitly present, not indeed in consciousness but in the unconscious; whereas the whole truth is exhausted when we say that it was consciously but only implicitly present—active, but not active all alone. Second, having traced out how a certain act was learned, we are apt to suppose that its history is repeated whenever it is performed afresh—that the wishes and ideas that were essential to its original performance must be unconsciously present whenever it is once more performed—neglecting thus the fact that what is retained and renewed consists of responses, rather than experiences. What is renewed when a learned act is performed is not the history of the act, but the act itself. In a new situation, the act is part of a new performance, and its motivation is to some degree new.

Though his theories are open to criticism, Freud has made important contributions to the study of personality. The same can be said of other schools of psycho-pathology. Jung and Adler deserve mention as representing varieties of psychoanalysis that differ more or less radically from that of Freud. Outside of the psychoanalytic school altogether, Janet and Morton Prince have added much to psychological knowledge from their studies of dissociated and maladjusted personalities. In endeavoring to assist the maladjusted individual, all these schools have much in common, since they all seek to bring to his attention elements in his personality

of which he is not clearly aware. Clear consciousness of implicit or dissociated elements in one's personality often proves to be a step towards a firmer organization of the personality and towards a better adjustment to the conditions of life.

EXERCISES

1. Outline the chapter.

2. Mention some personal traits that appear when the individual is dealing with inanimate things, and some that only appear in dealing with other persons.

3. Construct a "rating scale" for the trait of independence, as follows. Think of some one who is extremely independent, and call him A; of some one who is at the opposite extreme and call him E; of some one standing halfway, and call him C; and fill in the positions B and D with other persons standing between A and C and between C and E, in this matter of independence. You now have a sort of measuring rod, with the five persons A, B, C, D and E marking degrees of the trait. To rate any other individual, consider where he belongs on this scale—whether even with A, with B, etc.

4. How does the embarrassing "self-consciousness" of one who is speaking in public differ from simple consciousness of self?

5. Consider what was conscious and what unconscious in the following case of "shell shock": A sharpshooter had a certain peekhole in the front of the trench through which he was accustomed to take aim at the enemy. The enemy evidently spotted him, for bullets began to strike close by as soon as ever he got up to shoot. He stood this for a time, and then suddenly lost the sight of his right eye, which he used in aiming.

6. Explain the difference between unconscious action of the dissociated type and of the implicit type.

REFERENCES

For attempts to utilize psychological methods in the study of personality, see F. L. Wells, *Mental Adjustments*, 1917; also Chapter 11 in Watson's *Psychology*, 1919.

Much interesting psychological material, along with a good deal of philosophical discussion, is contained in James's chapter on the "Consciousness of Self" in Vol. I of his *Principles of Psychology*, 1890.

For a discussion of the unconscious, see the symposium on *Subconscious Phenomena*, 1910, participated in by Münsterberg, Ribot, Janet, Jastrow, Hart and Prince.

On dissociation, see Morton Prince's *Dissociation of a Personality*.

For Freud's doctrine of the unconscious, see his *Psychopathology of Everyday Life*, translated by Brill.



INDEX

- Abulia, 499, 539-541, 545-546
- Accessory sense-apparatus, 192-196, 200
- Acquired reactions, 89-90, 94, 99-102, 112-114, 144, 247, 296-329, 399
- Adaptation, of attention, 247, 260; negative, 302-303, 310, 312; sensory, 224-225, 447
- Adjustment, 72, 78-79, 131, 178, 382, 385, 420, 430, 431, 433
- Adler, 569
- Adrenal glands, 123-124, 554
- Advantage, factors of, 245-248, 259, 382; law of, 256
- Aggressive behavior, 160-161, 164-165
- After-images, 226-227, 451-452
- Ambiguous figures, 253-254, 425
- Analysis, of motives, 565-566, 569; of sensations, 197, 201, 203, 205-206, 211-212, 230, 233
- Anger, 118, 122-123, 125-126, 131-132, 158-159, 163, 300-301, 429-430
- Animal behavior, 8-9, 14, 39-40, 76-79, 93-94, 97, 105-107, 109-111, 116, 121-122, 141, 145, 147, 148, 156, 159, 160, 298, 302-311, 313-314, 317-320, 436, 463-464
- Aphasia, 57-60, 62, 428
- Appetite, 125, 126
- Applied psychology, 3-4
- Apraxia, 57, 63-64, 428
- Aptitudes, 101, 288-289, 291, 293
- Area, auditory, 50, 59-60, 62; motor, 50-57; olfactory, 62-63; somesthetic, 50, 62-63; speech, 58-60, 62; visual, 50, 53, 62-63
- Aristotle, 394, 454
- Art, 182-183, 512-516
- Assertiveness, *see* Self-assertion
- Association, 366; by contiguity, 395-398, 405; free, 376-381; by similarity, 395-396, 405-408, 519; laws of, 389-417; controlled, 381-385, 413-414, 417
- Association fibers, 56, 416-417, 424
- Atrophy through disuse, 349, 390, 415
- Attachment of stimulus and response, 25, 34-35, 53-54, 84, 92, 112, 135, 139, 298-301, 303, 311, 338, 372, 377-379, 390, 392, 394, 399-412, 414-417, 433
- Attention, 244-269, 381, 421, 433
- Attitude of attention, 249; of thought, 249, 464
- Autistic thinking, 508-510
- Automatism, 26, 328, 338, 383-384, 433, 525, 563
- Autonomic nerves, 124-125
- Auto-suggestion, 549
- Avoiding reaction, 24-25, 142-144, 305, 310
- Axon, 31-38, 51-52, 56, 61, 64, 189-192
- Baldwin, 243
- Basilar membrane, 196, 234-235
- Behavior psychology, 1, 8-9, 13, 21
- Bergson, 565
- Betts, 388
- Big, appeal of the, 515-516
- Binet, 272-273
- Binet tests, 272-275
- Binocular, rivalry, 253-254; vision, 442-443
- Biology, 5; liking for, 182
- Black, a sensation, 218, 223-224
- Blends, 197-199, 202-203, 205-206, 219-220, 232, 301, 424, 500
- Bloomfield, 104
- Boasting, 169, 495
- Book, W. F., 325
- Brain, 14-15, 28-30, 49-66, 292-293; stem, 29-30, 32, 33, 50
- Brown, Warner, 449
- Bryan, 321

- Cajal, 51, 61, 239
 Callosum, 56, 62
 Cannon, 136
 Carr, 314
 Caution, 156, 511
 "Censor," 505-506
 Central neurone, 37-39
 Cerebellum, 29-30, 35, 50, 65
 Cerebrum, 29-30, 50-64, 292-293
 Character, 529, 555
 Child, behavior, 91-92, 94-97, 100-101, 138, 141, 143-144, 147, 150-159, 162-168, 297-298, 300-301, 303-304, 313-314, 319, 357-358, 434-435, 437, 445, 481-483, 485-487, 490, 501, 504, 506, 526-527
 Choice, 528-535
 Cochlea, 192, 195-196, 234-235
 Co-conscious, 564
 Collecting instinct, 141
 Color, liking for, 183; circle, 207; cone, 209; pyramid, 209; sense, 204-228; theories, 220-224; tone, 206-207, 213-215; triangle, 217; zones, 211-212; mixing, 214-217
 Color-blindness, 209-211
 Colored hearing, 376
 Combination, 80, 135, 140, 148, 260-261, 299, 301, 306-308, 311, 323-326, 334, 479, 519; law of, 263-264, 398-417, 431-432, 468
 Comparative method, 14-15
 Comparison, 466-467
 Compensatory movements, 236-238
 Complementary colors, 216-217, 227-228
 "Complexes," 381
 Conditioned reflex, 303-304, 312, 401-402
 Cones, 191, 226
 Consciousness, 7-8; of animals, 8-9; degrees of, 172, 265-267, 338, 383-384
 Constant error, 447-448
 Constitution, native, 91, 92, 98, 271, 289-292
 Constructiveness, 154, 482
 Contentment, 156-157
 Contiguity, association by, 395-398, 405
 Contrast, visual, 227-228
 Control, 55, 257, 298, 320, 335-336, 348, 381-385, 413-414, 417, 484, 511
 Coördination, 30, 37-39, 41, 55-59, 66, 260-261, 299, 410-412, 534-535
 Correlation method, 14-15, 283-285
 Cortex, 50, 52, 56-63, 293, 414, 423
 Counter-suggestion, 549
 Cramming, 342, 346
 Criteria of instinct, 92, 97, 138
 Criticism, 499-500, 503, 505, 508-512, 547
 Crying, 144
 Curiosity, 154-157, 181, 244, 258
 Curve, of distribution, 280; of forgetting, 350, 390; of learning or practice, 307, 316, 321, 325, 390
 Cutaneous senses, 197-201, 224, 440, 451
 Dallenbach, 352
 Daring, 489, 518-519
 Darwin, 127, 136
 Davenport, 104
 Day dreams, 493-499
 Decision, 528-535
 Defense mechanisms, 533, 535
 Defensive reactions, 24-25, 142-144, 159-160, 162-164, 310
 Delayed reaction, 76-77, 429
 Delusion, 509
 Dendrites, 31-32, 34-35, 51, 61, 190, 414
 Detachment of response from stimulus, 299, 302, 310, 328
 Determining tendency, 72, 380-385
 Dewey, 480
 Differential psychology, 3, 12, 180, 210, 271, 272, 274, 279-280, 286, 291-292, 368-370, 374, 548
 Digestion, 121-123, 125
 Discord, 232
 Discovery, 421, 462
 Discrimination, 435-437
 Disgust, 127, 312
 Dissociation, 559-561
 Distraction, 259-260, 355-356
 Distribution of intelligence, 274-275, 279-281
 Dizziness, 238
 Domination, 165
 Dot figure, 252
 Doubt, 472-473
 Drainage, 269
 Dreams, 499-508
 Ear, 191-192, 195-196, 236-238
 Ebbinghaus, 350, 365

- Economy of effort, 151; in memorizing, 338-346, 353
- Effect, law of, 391-393, 413
- Effort, 127, 162, 259-260, 534, 539
- Egocentric response, 380
- Elementary, feelings, 173, 184-185; sensations, 197-198, 201, 203, 211-212, 216-220, 233-234
- Elimination in learning, 306, 308-309, 310, 314, 327
- Emotion, 118-136, 137-169, 173, 299-301, 345, 355, 361, 381, 513-514, 554, 561
- Empathy, 491, 515-516
- Emulation, 165-166
- End-brush of an axon, 33-36, 38, 61
- Endocrine glands, 122-123, 554
- Energy, conservation of, 40; dammed-up, 82-84, 301, 309, 393; released, 535-546; stored, 40-41, 46
- Envy, 166, 168
- Equilibrium, 65
- Errors, 446-459, 467
- Escape tendency, 142-144, 489, 498-499
- Esthetics, 443-444, 457-458
- Euphoria, 120, 151
- Excitement, 126
- Exercise, effect of, 297-298; law of, 389-391, 393-394, 413-415
- Experiment in psychology, 12-15, 93, 302, 333
- Explanation, 471-472
- Exploration, 154-157, 244, 249-252, 258, 288, 305, 421, 462-465, 470
- Expressive movements, 126-128
- Eye, 32, 34-35, 62, 191, 193-195; movements of, 249-251
- Facilitation, 54-55, 78, 83-85, 248, 257, 263, 382-385, 413-414, 417
- Factors, in attention, 245-248, 259; in intelligence, 285-288; in memorizing, 345-346; in personality, 553-555; in recall, 379, 382
- Faculties, 523
- Fallacy, 467-468, 479
- Father complex, 506
- Fatigue, 73-74, 119, 123, 145, 151
- Fear, 125-126, 129-133, 142-144, 153, 303-304, 489, 497-498, 504, 513, 516, 539-540; abnormal, 133, 497-498
- Feeble-mindedness, 275, 290-292, 446
- Feeling, 172-185; of activity, 45-46; of excitement, 126, 184-185; of familiarity, 185, 357-360; of readiness, 75, 383; of tension, 78-79, 184-185
- Feeling-tone, 174-175, 178, 180-181
- Feleky, 136
- Fernald, 388
- Fiction, 512-513
- Fighting, 158-161
- Fissures of the brain, 50
- Fixation, 298
- Fluctuation of attention, 254-255
- Flying, 93
- Forgetting, 349-353, 415
- Forgotten name, 356, 563-564
- Fovea, 193, 211, 226
- Free association, 376, 504, 507; test, 380
- Frequency, 379, 390, 433
- Freshmen, intelligence of, 279-281
- Freud, 505-508, 522, 566-569, 571
- Galton, 368, 388
- Gamble, 243
- Games, 487
- Gates, 339, 365
- General psychology, 4-5
- Genetic method, 15-16, 90
- Genius, 99
- Glands, 25, 122-124, 303
- Gliding dream, 503
- Golden section, 444
- Gray matter, 35-36, 50-52, 56, 61-62
- Gregariousness, 110, 146-147
- Group tests, 276-277
- Habit, 89, 112-114, 157, 247-248, 260, 328-329, 381
- Hallucination, 375-376, 501, 547
- Hart, 571
- Harter, 321
- Hearing, 50, 59-60, 62, 228-235, 439-440
- Helmholtz, 220, 234, 475
- Helplessness, 144, 149
- Henning, 203, 243
- Herd instinct, 110, 146-147
- Heredity, 91, 98, 100-101, 113, 289-292
- Hering, 220-221

- Hero**, worship, 168; conquering and suffering, 494-496, 509
Herrick, 44, 67
Hesitancy, 530
Hicks, 306, 314
Higher units, 323-326, 334, 410-412
Hollingworth, 20, 104, 243
Homing, 78, 146
Humor, theories of, 157-158
Hunger, 79-81, 120, 140-141, 204
Hunter, 88, 295
Hunting instinct, 72, 78, 140-141
Hypnosis, 349, 547-548
Hypothesis, 473-475

Ideomotor action, 527-528
Illusion, 424, 450-459, 500, 547
Imageless thought, 374
Imagery, mental, 368-376, 499-500; in perception, 425-427; types, 370
Imagination, 481-520, 525
Imitation, 319, 486
Impulse, 132-135, 155, 167, 177, 299, 524-525, 539
Incentives, 541-546
Incidental memory, 346-348, 397
Independence, 163-164
Individual, 91
Individual psychology, *see* Differential psychology
Induction, 374-375
Inference, 465-468, 475-476, 479
Inferiority, sense of, 166, 168, 496, 510, 555
Inheritance of acquired traits, 113-114
Inhibition, 25, 54-55, 78, 83-84, 122-125, 248, 257, 263, 314, 382, 384, 429-430, 528, 540
Initiative, 545
Insane, 259, 508-509
Insight in learning, 316-320
Instinct, 105-116, 137-169, 179, 181, 488-489, 492, 513, 554; criteria of, 92, 97, 138; and emotion, 134-135; modification of, 299-301
Integration, 558-561
Intelligence, 90-91, 271-293, 538, 555; tests of, 3, 272-277, 281-283
Intelligence quotient, 274-275, 289-290
Intensity of sensation, 206; of reaction, 379, 391, 433
Interest, 181-184, 248, 257-259

Interference, 355-356
Internal secretions, 122-123, 554
Intra-uterine life, 90-92
Introspection, 10-11, 19
Invalidism, 546
Invention, 421, 475, 484, 485, 509-512, 517, 519
"IQ," 274-275
Isolation, 431-432, 435-437, 455-459, 468, 479

James, 117, 129, 136, 331, 365, 418, 480, 511, 551, 561, 571
James-Lange theory, 128-130
Janet, 569, 571
Jastrow, 571
Jennings, 88
Jost, 342
Judd, 461
Judgment, 550
Jung, 388, 569

Kimmins, 522
Kinesthesia, 240
König, 217

Ladd, 44
Ladd-Franklin, 221-224, 243, 453
Lange, 129
Lashley, 88
Laughter, 157-158, 161
Law, of advantage, 256; of association, 394-398; of attention, 256, 262-263, 267; of combination, 263-264, 398-417; of effect, 391-393; of exercise, 389-391, 393-394; of habit, 389; of reaction, 256, 262-263, 267; of selection, 256, 262, 378, 382; of shifting, 256, 263; of tendency, 81, 263
Learning, 93-94, 96, 99, 112, 113, 143-144, 296-329; laws of, 389-417, 433
Libido, 507
Light, 212-213
Likes and dislikes, 178-184, 291, 492-493, 513
Linkage, *see* Attachment
Lobes of the brain, 50
Local sign, 440-441
Locomotion, 93-97, 99, 152-153, 486
Logic, 475-476
Love, 535
Loyalty, 169, 531

- Make-believe, 482-483, 508
 Management, of action, 541-546;
 of attention, 267-268; of memory,
 338-346, 353, 356, 360-363; of
 reasoning, 478-479
 Manipulation, 154, 315, 481-483
 Massed learning, 341-343, 345
 Mastery impulse, *see* Self-assertion
 Martin, 28
 Mathematics, liking for, 181-182
 Mating instinct, 97, 116, 147-148
 Maturing, 92, 96
 Maury, 501
 Maze learning, 305-308, 313-314
 McDougall, 136, 171, 418, 551
 Meaning, 421, 482-483
 Median, 280
 Memorizing, 333-346, 360-363
 Memory, 332-363
 Memory colors, 426
 Mental action, 6-7, 45-47
 Mental age, 273-274
 Mental set, 72, 382-385, 413-414,
 417, 433, 452
 Mental work, 384
 Methods of psychology, 9-16
 Mnemonic systems, 363
 Modification of reactions, 297-299
 Moll, 551
 Morale, 543-545
 Morgan, 270
 Mother complex, 506
 Mother instinct, 148-150, 159, 161
 Motive, 69, 72, 84-85, 137, 257-258,
 469-473, 487-499, 501-510, 513-
 517, 528-546, 565-570
 Motor, area, 50-54; centers, 50-59,
 65, 66; nerve, 27, 30-33, 36-37,
 39, 50, 52-53
 Movement, expressive, 126-128; re-
 flex, 24-26; skilled, 55-59, 268,
 321-326, 410-412; voluntary, 53-
 55, 298
 Moving pictures, 454
 Müller-Lyer illusion, 455-456, 459
 Münsterberg, 265, 571
 Muscle sense, 225, 238-240
 Music, 235; liking for, 182-183, 291
 Music deafness, 60
 Native traits, 89-102, 297
 Negative adaptation, 302-303, 310,
 312, 413
 Nerve, 26, 30, 32; autonomic, 124-
 125; cell, 31-36, 51, 414; center,
 26, 29-30, 49-66, 76, 82-84, 96,
 107, 125, 293; fiber, 32
 Nervous system, 27-29, 32, 41, 124
 Nesting, 105, 110-112
 Neurone, 32-36, 51, 61, 346, 414-
 417
 Newton, 212
 Nicoll, 522
 Nightmare, 504
 Noise, 231, 236
 Nonsense syllables, 334
 Non-sensory recall, 373-375
 Norsworthy, 20, 104, 522
 Object blindness, 62
 Objective observation in psychol-
 ogy, 9, 11-13
 Observation, 267; learning by, 317-
 320, 333-337, 348, 367-375
 Obstruction, 162-163, 177, 534-539
 Organic needs, responses to, 139-
 145
 Organic sensations, 119-120, 128,
 204
 Organic state, 72-74, 79, 82, 119-
 126, 132-133, 175-176
 Original nature, 91, 92, 98
 Organization of the individual,
 527, 529, 532, 558
 Otolith, 192, 238
 Overlapping, 324-325, 412
 Overtones, 230, 438
 Pain, 173, 198-201
 Paired associates, 336, 347, 404
 Paralysis, 57, 547
 Parental instinct, 148-150
 Parsons, 243
 Path, auditory, 62; motor, 51-53,
 62; tactile, 62, 64
 Pathological method, 16
 Patterns, 204-205
 Pechstein, 344
 Perception, 45, 60, 62-63, 65-66,
 419-459, 462, 465, 468, 475-476,
 479, 520
 Performance tests, 275-276
 Perseveration, 355
 Personality, 552-570
 Perspective, 435, 441-442, 453-454
 Phrenology, 52, 65, 293
 Physiognomy, 445-446
 Physiological limit, 321
 Physiology, 6-7
 Physique, 553

- Piano theory of hearing, 234-235
 Piéron, 342
 Pillsbury, 270, 295
 Pintner, 295
 Pitch, 229-230, 450
 Place associations, 304, 305, 315, 333
 Plan, 483, 493, 539-540
 Plateau, 322
 Play, 139, 148, 151-152, 160, 485-499, 504-505, 517
 Pleasantness and unpleasantness, 173-180, 184-185
 Poffenberger, 20, 104, 243
 Poggendorf illusion, 457, 459
 Practice, 177, 298, 304-310, 314-317, 321-327, 360-363, 433, 538; curve, 307, 316, 321, 325, 390, 542
 Preparation for action, 22-25, 72, 74-77, 427-430
 Preparatory reactions, 77-84, 111-112, 125-128, 132, 139-140, 145, 147
 Prestige, 549
 Prince, 559, 564, 569, 571
 Problem solution, 385, 465, 469-470, 477, 514
 Proofreader's illusion, 453
 Protozoa, 39-40, 188, 302
 Psychiatry, 16
 Psychoanalysis, 505-508, 521, 533, 567-569
 Psychology, definition of, 1-2, 5-8, 17-18; methods of, 9-16; varieties of, 2-6
 Psychopathology, 16, 498, 540-541, 545-550, 567, 569
 Punishment, 304-305
 Purpose, 69-71, 75, 78, 524-527, 542
 Puzzle experiment, 308-310, 315-319, 463-464
 Pyle, 343
 Pyramid cells, 51, 52, 61
 Pyramidal tract, 52-55, 57, 62
 Random activity, 151-152
 Rationalization, 470-471, 531
 Raynor, 331
 Reaction, 22-26, 39-41, 45-49, 65-66, 68, 75, 84, 256, 262-263, 266, 423, 428; acquired, 89-90, 94, 99-102; delayed, 76-77, 429; native, 89-102; preparatory, 77-84, 111-112, 125-128, 132; time, 22-24, 75, 424
 Reading, 250-251, 258, 262, 267-268, 384, 427, 453, 512-513
 Reaney, 522
 Reasoning, 320, 422, 462-479, 520; in animals, 310, 317-418, 463-464
 Recall, 354-356, 366-385, 413, 422, 469-471, 500, 519, 563
 Recency, 345, 356, 379, 390, 433, 511, 563
 Recitation in memorizing, 339-341
 Recognition, 187, 357-360
 Red-green blindness, 210
 Reflex, 24-26, 53, 107-109, 256, 297; conditioned, 303-304; control of, 54-55; arc, 26-30, 34, 36-37; centers, 30, 53
 Relationships, response to, 286-287, 317, 320, 333-336, 345, 404-405, 432, 467-468, 520
 Relief, 79, 84
 Reproduction, instinct of, 116
 Respiration, 37, 55, 141, 176, 527
 Response by analogy, 405-408, 435, 452-455
 Restlessness, 78-79, 112
 Retention, 286, 302, 349-353, 360, 562
 Retina, 191, 193, 195, 210-211, 233, 441-442
 Rivery, 376-380
 Ribot, 571
 Rivalry, 165-166, 474, 489, 543; binocular, 253-254
 Robinson, 522
 Rods, 191, 226
 Rotation, sense of, 236-238
 Rosanoff, 20
 Rote learning, 333, 337
 Royce, 522
 Ruger, 316
 Sanford, 252
 Satisfaction, 79, 84, 109-110, 132, 472, 487-499, 501-510, 513-517, 533-535, 540
 Saturation of colors, 207-208, 213-214, 217
 Scatter, 23, 273, 298, 448
 Schopenhauer, 565
 Science, 3-4, 473-475; liking for, 181-182
 Scott, 93, 551
 Seashore, 295
 Secondary personality, 559-561, 564
 Selection, 256, 262, 378, 382

- Self, 428, 555-558
 Self-activity, 46-47
 Self-assertion, 158, 161-169, 181, 183, 258-259, 287, 472-473, 489-496, 502-503, 508, 513, 515-516, 531, 536-537, 545-546, 549, 556-558
 Self-criticism, 509-511
 Selfishness, 557
 Self-preservation, 115-116, 507
 Semicircular canal, 192, 194, 195, 225, 236-238, 486
 Sensation, 6, 19, 46, 60, 62-64, 120, 187-240; and feeling, 173-174; feeling-tone of, 174-175; and perception, 423-425; recall of, 368-376
 Sense, cells, 189-192; organs, 188-196, 199-200, 236-239, 249; perception, 421-422
 Sensory, nerve, 27, 30, 32-34, 36-38, 188-189, 191, 193, 196, 239-240; areas, 50, 59-66, 423
 Setting of an object, 358
 Sex, attraction, 97, 116, 125, 147-148, 488, 507-508, 534-535; differences, 281
 Sex differences, 281
 Shame, 166, 168
 Shell shock, 504
 Shifting of attention, 251-256
 Short-circuiting in the process of learning, 338, 405, 568
 Shyness, 166
 Sight, 32, 34-35, 62, 191, 193-195, 204-228, 231-234, 441-443
 Sign and meaning, 421, 437-446
 Signal experiment, 304-305, 312
 Similarity, association by, 395-396, 405-408
 Size-weight illusion, 459-460
 Skill, 55-59, 268, 282, 348, 352, 410-412, 428, 482, 488
 Skin senses, 197-201, 224, 440, 451
 Sleep, 145, 499-500
 Smell, 29, 32, 62, 63, 190, 201, 203-204, 224
 Snyder, 343
 Sociability, 181, 183-184, 489, 492
 Social, behavior, 145-151, 510, 552, 558-559; perception, 444-446, 512, 555
 Sociology, 5
 Song of birds, 93-94
 Sound, 228-231
 Space, 439-443
 Spaced repetition in learning, 341-343, 345, 390
 Spaulding, 93
 Span of attention, 261-262
 Speech, 6, 60, 94, 98, 113, 154, 325, 402-403, 416; centers, 57-62
 Spinal cord, 29-33, 50, 52, 55, 64
 Spite, 507
 Staircase figure, 253
 Starch, Daniel, 20, 331
 Starr, 56
 Statistical measures, 14-15, 280, 283-285
 Stereoscope, 254, 442
 Stiles, 44, 67
 Stimulus, 22, 24, 26-27, 34, 40-41, 46-49, 188, 484-486, 500-501; central, 48-49, 368, 371, 422, 468, 500, 528; internal, 41, 47, 79, 119, 128, 132
 Story-telling, 482-483
 Straining, 162-163
 Strong, 246, 351
 Struggle for existence, 114
 Subconscious minds, 563-564
 Sublimation, 533-535
 Submissive tendency, 166-169, 287, 516, 549
 Substitute, response, 299-301, 305, 311, 328, 400, 409-413, 430, 436-437, 498-499, 533; stimulus, 298, 300, 303, 311, 368, 371-372, 376, 400-409, 416, 434, 568
 Suggestion, 546-550
 Suppression, 505-508, 533, 566-567
 Surprise, 155
 Survival value, 114, 139, 148, 151, 160
 Survivals, 127
 Sustained attention, 257-260
 Syllogism, 476-479
 Symbols, 383, 468, 505-507
 Symmetry, 444
 Synapse, 34-35, 96, 414-416
 Synesthesia, 376
 Tact, 555
 Taste, 189-190, 201-203, 224
 Taussig, 522
 Telegraphy, learning of, 321-323
 Temperament, 553-554

- Temperature, responses, 141-142;
 sense, 197-201, 224-225
 Tendency, 68-85, 109-112, 116, 130-
 135, 137-169, 177, 257, 263, 299-
 301, 309, 348, 367, 382, 392-393,
 408-409, 417, 483-499, 501-510,
 512-516, 528-546, 561
 Terman, 272, 295
 Testimony, 347, 352, 397
 Tests, 3, 12,* 14, 272-277, 281-283,
 548
 Thalamus, 56, 62, 64-65, 178
 Thinking, 48-49, 319-320
 Third dimension, 441-443
 Thirst, 79-81, 120-121, 139-140, 179
 Thorndike, 20, 104, 171, 331, 418
 Thought and action, 539-541
 Thrill, 489, 498-499
 Thyroid gland, 123, 554
 Timbre, 231
 Time, 438-439, 447
 Titchener, 186, 242, 270, 461
 Touch, 50, 62, 63, 197-201; spots,
 198
 Toys, 486-487
 Training of memory, 360-363
 Traits, native and acquired, 89-102
 Transfer, 316-317, 361-362
 Trial and error, 112, 305, 309, 311,
 313, 315, 335, 392, 409, 424, 426,
 430, 462-465, 526
 Typewriting, learning of, 324-325,
 411-412, 518, 525-526, 537
 Unconscious, activity, 265-266, 383-
 384, 505-508, 525-526, 562-565;
 emotion, 118-119; feeling, 172;
 motive, 565-569; retention, 348-
 349, 562
 Unintentional learning, 346-348
 Utility, of emotion, 125-127; of in-
 stinct, 114, 144-145; of reflexes,
 125
 Vacillation, 530
 Variability, 23, 273, 298, 369, 447-
 448
 Verification of hypotheses, 473-475
 Visual, area, 62; images, 370; per-
 ception, 441-443, 450; sensations,
 204-228, 231-234
 Visualist, 370
 Vocalization, 93-94, 154
 Voluntary action, 298, 524-528
 Vowels, 231
 Walking, 95-97, 99, 153
 Warming-up, 74, 119-120, 343, 391
 Warren, 171, 242, 418, 461
 Washburn, 19, 88, 331
 Watson, 20, 88, 117, 171, 307, 308,
 331, 571
 Watt, 243
 Weber's law, 449-450
 Weight, perception of, 448-450,
 459-460
 Wells, 571
 Whipple, 295, 365
 White matter, 32, 35-36, 56, 62
 Whitley, 20, 104, 522
 Whole and part study, 343-346
 Will, 523-550; to learn, 346-348; to
 live, 565
 Wish, 496-497, 501-509, 565
 Word blindness, 62; deafness, 59
 Worry, 497-499
 Wundt, 184
 Yerkes, 104, 295
 Young, 220
 Youth, 147, 164, 495, 519
 Zoellner illusion, 459

3rd memory

4th memory

Hi 8926 }
King 7806 }

University of Toronto
Library

DO NOT
REMOVE
THE
CARD
FROM
THIS
POCKET

Acme Library Card Pocket
Under Pat. "Ref. Index File"
Made by LIBRARY BUREAU

Woodworth, Robert. Sessions

R

F

Mo

BF
13
W8

