

RADON INFORMATION SYSTEM FOR NEW HOUSE CONSTRUCTION

By

WIN-GINE LI

A DISSERTATION PRESENTED TO THE GRADUATE SCHOOL  
OF THE UNIVERSITY OF FLORIDA IN PARTIAL FULFILLMENT  
OF THE REQUIREMENTS FOR THE DEGREE OF  
DOCTOR OF PHILOSOPHY

UNIVERSITY OF FLORIDA

1995

To my parents and in memory of my younger brother

## ACKNOWLEDGMENTS

This work was sponsored by the Florida Department of Community Affairs, whose funding is sincerely appreciated. I wish to thank the colleagues who worked on the project with me. Special thanks are due to Dr. David Hintenlang, Mr. Kaiss Al-Ahmady and Mrs. Huong Iselin from the Department of Nuclear Engineering and Sciences for their support and encouragement.

I would like to express my sincere thanks to Dr. Fazil T. Najafi, the committee chairman, for his compassionate guidance and patience in making this study possible. I sincerely thank Dr. Paul Thompson, Dr. Mang Tia, Dr. John Staudhammer and Dr. Elroy Bolduc for serving as my committee members. I thank them for taking their precious time in helping me complete this work.

My family has supported me so much for more than six years from thousands of miles away. Their love and encouragement have motivated me to complete this work. I deeply appreciate their sacrifices and support both financially and spiritually.

My host parents, Rachel and Scott Gray, have given me much love during my stay in the United States. I would like to thank the Lord for His everlasting love to make this work possible. Also, Dr. Fadi Nassar, Mr. Xiaoyu Fu, Mr. Quan-

Yang Yao, Dr. Wei-Tong Chen, Mr. Bill Epstein, Ms. Candance Leggett, Ms. Irene Scarso, and all my friends whose consideration and support have made me feel comfortable far from home.

TABLE OF CONTENTS

ACKNOWLEDGMENTS ..... iii

LIST OF TABLES ..... ix

LIST OF FIGURES ..... xi

ABSTRACT ..... vxi

CHAPTER

1 INTRODUCTION..... 1

    Research Overview..... 1

    Statement of Problem..... 1

        Radon Information Is Not Well Organized and  
        Accessible ..... 3

    Objective of Work..... 3

    Scope of Work..... 4

    Description of Chapters..... 5

2 RADON RISK IN HEALTH AND ITS CAUSES..... 7

    Introduction..... 7

    What Is Radon?..... 7

    Potential Radon Exposure Risks..... 7

    Chronological Studies and Statements of Radon Risks.... 10

    Radon and Liability..... 15

    Radon Decay Chain..... 16

    Radon Damage Mechanism..... 18

        Radon Measurement Units ..... 20

            Radon Concentration..... 20

            Radon Progeny..... 21

    Radioactive Decay ..... 22

        Decay Relationship between Parent and Daughter.... 23

    Summary..... 25

3 RADON TRANSPORT IN STRUCTURES..... 26

    Introduction..... 26

    Review of Literature ..... 26

    Research Subjects..... 28

    Sources that Contribute to Indoor Radon..... 29

Radon Transport in Substructures.....	29
Radon in Soil and Its Movement .....	29
Radon Emanation Coefficients .....	31
Indoor Radon Prediction Model .....	32
Soil Permeability .....	33
Radon Flows Through Different Soil Layers .....	38
A Proposed Mitigation Method .....	40
Soil Permeability in Different Depths .....	40
Radon from Geological Consideration .....	42
Geological Elevated Radon Summary .....	43
A Generalized Geological Map for the State of Florida.....	45
Phosphate Region and Indoor Radon Levels in Florida.....	50
Summary of Radon Transport in Substructures.....	50
Radon Transport in Superstructures.....	50
Radon Transport through Concrete Floor Slab .....	53
House Water .....	55
Emanation from Building Materials .....	56
House Ventilation .....	58
Ventilation Rates and Indoor Radon Concentrations ...	59
Radon Entry Rate .....	59
Pressure-driven Flow .....	64
Summary of Radon Transport in Superstructures.....	68
4 ANALYSIS OF HOUSE RADON AND CRACK STUDY.....	71
Introduction.....	71
House Physical Characteristics and Soil Radon.....	71
Soil Data Analysis.....	75
Crack Study.....	77
Crack Research Process .....	78
Data Analysis .....	79
Correlation Analysis.....	81
Calculation of Crack Parameters .....	84
Comparison of Crack Characteristics with Indoor Radon.....	84
Potential Crack Radon Entry Analysis .....	84
Crack Resistance Analysis .....	88
Crack Study Summary.....	90
Infiltration and Indoor Radon Test Results.....	91
Two Radon Research Experiments.....	95
Effectiveness of Tube Length on the Measurement of Radon Concentration.....	97
Equipment Used.....	97
Testing Procedures.....	97

	Site Selection and Testing.....	98
	Test Results.....	98
	Discussion of the Experiment.....	101
	Indoor Radon Concentration Variation Due to	
	Pressurization.....	102
	Objective of the Experiment.....	102
	Experimental Procedure.....	102
	Experimental Results.....	103
	Discussion of the Experiment .....	103
	Summary.....	105
5	CONSTRUCTION METHODS.....	106
	Introduction.....	106
	State-Of-The-Art Construction Mitigation Methods.....	106
	Enkavent Mat Method.....	107
	Installation Procedures.....	108
	Suction Pit Method.....	108
	Perforated Pipe Method.....	111
	Mechanical Barrier.....	111
	Change of Foundation Soil.....	115
	Fill Materials or Layered Natural Soils .....	116
	Construction Materials.....	117
	Costs Comparisons.....	118
	Planned Mechanical Systems.....	118
	A New Radon Mitigation Method.....	121
	Summary.....	123
6	ESTABLISHMENT OF KNOWLEDGE BASE.....	124
	Introduction.....	124
	Effective Information Retrieving.....	125
	Expert System Applications.....	125
	Advantages of Managing Radon Information by Expert	
	Systems.....	125
	Performance Improvement and Knowledge Transferring	
	through Expert Systems.....	126
	The Structure of Knowledge-Based Expert Systems ....	127
	Objective of the Knowledge Base Development.....	129
	Knowledge Acquisition.....	130
	Selection of Knowledge Domain .....	130
	Control Mechanism of This System.....	132
	Database Development.....	132
	Identify Target Users .....	133
	Establish Problem Boundaries .....	133
	Obtain Expert Support .....	135
	Organize the Facts from the Knowledge Databases.....	135

Design Rules .....	137
System Development.....	139
Homeowner Database .....	139
Contractor Database .....	143
Researcher Database .....	145
Sample Applications of the Expert System .....	149
System Testing and Validation.....	156
Summary.....	157
7 CONCLUSION AND RECOMMENDATIONS.....	159
Summary and Conclusion.....	159
Effectiveness of the Radon Mitigation Methods.....	159
Cost-Effectiveness of the Mitigation Systems.....	160
Advantages of Radon Information System.....	160
Recommendations.....	161
Author's Contribution to the Advancement of Radon Knowledge .....	161
APPENDICES	
A STATISTICS PROGRAMS .....	163
Testing Equality of Four ACH Experiments.....	163
Indoor Radon and Its Correlation Tests .....	166
Sample Program Output: Normality .....	167
Sample Program Output: Correlation .....	169
B HYPERTALK PROGRAMS .....	170
HyperTalk Scripts.....	170
C EXAMPLE OF KNOWLEDGE BASE .....	192
Crack Sealant Knowledge Base.....	192
Crack Treatment Knowledge Base.....	195
Indoor Radon Prediction Knowledge Base.....	203
LIST OF REFERENCES .....	207
BIOGRAPHICAL SKETCH .....	215



LIST OF TABLES

<u>Table</u> .....	<u>page</u>
2.1 Organ Dose Ratios and Absolute Risk .....	9
2.2 Major Radon Studies and Statements .....	12
2.3 Radon Isotopes and Their Half-lives .....	19
2.4 Properties of Radon Progeny .....	19
2.5 Definition of Working Level .....	21
3.1 Soil Permeability .....	37
3.2 Utilization and Costs of Water Radon Mitigation Methods .....	57
3.3 Radon Emanation Rates .....	58
3.4 House Radon Entry Data .....	65
4.1 House Characteristics (Project of 1992) .....	72
4.2 Radon Test Results (Project of 1992) .....	73
4.3 House Characteristics (Project of 1993) .....	74
4.4 Radon Test Results (Project of 1993) .....	75
4.5 Crack Classification .....	78
4.6 House Characteristics .....	82
4.7 House Basic Statistics in the Crack Study .....	83
4.8 Correlations between Factors .....	83
4.9 Crack Resistance in Three Projects .....	90
4.10 Infiltration Rate and Indoor Radon Concentration... ..	93

4.11 Multiple Comparison of Means .....	94
4.12 Tube Lengths and Their Calculated Radon Readings (0-25 ft) .....	99
4.13 Tube Lengths and Their Calculated Radon Readings (25-50 ft) ..	100
5.1 Soil Changing Analysis .....	116
5.2 Costs of the Enkavent Mat System .....	119
5.3 Costs of the Suction Pit System .....	120
6.1 Radon Index Matrix .....	146
6.2 Probable Indoor Radon Level .....	147
6.3 Decision Table of the Indoor Radon Prediction .	158

LIST OF FIGURES

<u>Figure</u> .....	<u>page</u>
2.1 Radon Gas Damage Mechanism. ....	8
2.2 Decay Flow Chart of Uranium. ....	17
3.1 Major Research Subjects. ....	28
3.2 Soil Gas Radon Entry Mechanism and Affecting Parameters. ....	30
3.3 Effect of Moisture Content on the Relative Radon Emanation Coefficient [Nazaroff 1992]. ....	32
3.4 Indoor Radon Prediction by Using Soil Radon .....	34
3.5 Soil Gas Radon Mitigation by Perforated Pipe Systems. ....	41
3.6 Permeability Distribution of Different Pressure. ....	42
3.7 Average Indoor Radon Levels vs. Soil Radon Concentrations. ....	44
3.8 Average Indoor Radon Concentration vs. Soil Radon Concentration. ....	44
3.9 Generalized Geology Map of Florida [Otton 1993]. ....	46
3.10 Generalized Surface Materials Map for the State of Florida [Otton 1993]. ....	49
3.11 Phosphate Distribution in Florida [Roessler et al. 1983]. ....	51
3.12 Indoor Radon Levels of Florida [DCA 1994]. ....	52
3.13 Indoor Radon vs. House Ventilation Rate. ....	60
3.14 Radon Entry Rate for House "Robin Lane" .....	62
3.15 Radon Entry Rate for House "Summit Oaks" .....	63

3.16 Across Slab Differential Pressure for House "Summit Oaks" . . . . .	69
3.17 Across Slab Differential Pressure for House "Robin Lane" . . . . .	70
4.1 Distribution of Indoor Radon versus Subslab Radon. . . . .	76
4.2 Indoor Radon versus Subslab Radon. . . . .	77
4.3 Crack Map of House "Summit Oaks" . . . . .	80
4.4 Calculation of Total Crack Equivalent Area. . . . .	85
4.5 Average Subslab Radon and Indoor Radon Concentration. . . . .	86
4.6 Indoor Radon/Subslab Radon vs. Total Equivalent Crack Area. . . . .	86
4.7 Crack Resistances of the Houses Tested. . . . .	89
4.8 Indoor Radon Levels vs. Infiltration Rates. . . . .	96
4.9 Correlation between Indoor Radon and Infiltration Rates. . . . .	96
4.10 Tube Lengths and Their Radon Readings. . . . .	101
4.11 Radon Concentrations with Respect to Pressure Changes. . . . .	104
5.1 Enkavent Mat Placement. . . . .	109
5.2 Typical Enkavent Mat Layouts. . . . .	110
5.3 Suction Pit Placement. . . . .	112
5.4 Mechanical Barrier. . . . .	114
5.5 Solid Concrete Block Barrier and Vapor Barrier Installation Layout. . . . .	117
5.6 A Schematic Illustrating the Application of an Electrically Induced Soil-Gas Barrier. . . . .	122
6.1 The Basic Structure of a Knowledge-based Expert System. . . . .	128

6.2 Knowledge Base Expert System Establishment Procedures. ....	131
6.3 Schematic Diagram of the Interface System. ....	133
6.4 Hierarchical Structure of HyperCard. ....	138
6.5 Entity Relationship Diagram of Hypercard Elements. ...	138
6.6 Data Transferring Between Stacks. ....	139
6.7 Illustration of System Menu. ....	141
6.8 Key Elements of Homeowner Database. ....	141
6.9 Hierarchical Flow Chart of Homeowner Database. ....	142
6.10 Key Elements of Contractor Database. ....	144
6.11 Program Output of Radon Index. ....	147
6.12 Functions of Mitigation Methods Database. ....	148
6.13 Key Elements of Researcher Database. ....	148
6.14 Linkage of Hypercard and MacSmarts Expert System. ...	150
6.15 Expert System Output (crack.fig.1b) for Crack Treatments. ....	152

Abstract of Dissertation Presented to the Graduate School  
of the University of Florida in Partial Fulfillment of the  
Requirements for the Degree of Doctor of Philosophy

RADON INFORMATION SYSTEM FOR NEW HOUSE CONSTRUCTION

By

Win-Gine Li

May, 1995

Chairman: Dr. F. T. Najafi  
Major Department: Civil Engineering

Exposure to a high level of radon gas has been found to be a health threat. Researchers have concentrated on investigating the factors that affect radon entry and to designing mitigation methods in preventing radon intrusion. This research focused on radon gas prevention in new residential houses. Subjects related to house structures were thoroughly examined from substructures to superstructures. The major factors in the substructures investigated are soil type, soil moisture content, soil permeability, soil radium content, and geology, while in superstructures the factors investigated are concrete slab characteristics, floor cracks, types of building material,

house water, house ventilation, and pressure differentials. Based on the results of the University of Florida research projects, the data were analyzed. Correlations between various factors that might have an effect on radon entry were analyzed statistically. The parameters include soil radon, subslab radon, floor cracks and foundation type. In addition, the precision of radon measurements was discussed. The results have shown that the radon mitigation systems have successfully brought down indoor radon levels below the U.S. Environmental Protection Agency's standard.

Recent construction mitigation methods were reviewed. The methods are mostly based on the projects of the University of Florida and the U.S. Environmental Protection Agency. The installation procedures, materials used and costs of suction pit and Enkavent mat methods were all detailed in the content. A computer-aided design, Radon Information System, has been developed for use in construction for preventing radon intrusion. Procedures and materials used for constructing a radon resistant house were incorporated in the system. Radon Information System was developed for diagnosing radon problems and providing information available upon request. The system provides object-oriented databases in conjunction with an expert system to deal with radon problems. Final conclusion about the effectiveness of the radon mitigation methods and suggestions for future research subjects were described.

## CHAPTER 1 INTRODUCTION

### Research Overview

This chapter provides an overview of the entire research, describes the principal problem, and reveals the reasons this research is needed. A historical review of previous research and a brief introduction of each chapter are also presented.

### Statement of Problem

Radon is a radioactive gas which occurs in nature and can not be seen, smelled or tasted. Radon can be found in soils, and it can migrate through foundation slabs and enter houses. In an enclosed space, radon can accumulate. The risk of developing lung cancer from exposure to radon depends upon the concentration of radon and the length of time people are exposed. In general, the risk increases as the level of radon and the length of exposure increase. The U.S. Environmental Protection Agency (EPA) estimated that radon gas is responsible for 5,000 to 20,000 deaths annually in the United States. Although this is a large number, it represents less than 10% of total lung cancer deaths and



only 2% of all cancer deaths [Bodansky et al. 1987]. Based on the available information, the U.S. EPA suggests that homes with levels above 4 pCi/L (picocuries/liter) are harmful to human beings [EPA 1986].

The soil is the primary source of indoor radon in single-family houses in the United States [Nero and Nazaroff 1984]. Pressure-driven flow is a principal means by which soil gas enters houses; it is expected to be the predominant source of radon in houses with elevated concentration [Garbesi and Sextro 1989].

Since radon can migrate from soil through the slab, we should consider methods to prevent radon entry into houses while planning to build a new house. Some techniques have actually been applied during the construction of new houses. The applicability, cost feasibility, radon-prevention effectiveness, and durability of the techniques cannot be fairly assessed. The EPA-sponsored radon prevention projects in new house construction should provide a better evaluation of radon prevention alternatives.

The University of Florida (UF) has received research funds from the Department of Community Affairs (DCA) to evaluate the effectiveness of potential building design and construction criteria. The results will be used to reduce radon entry into new houses and to develop recommendations based on the evaluation for future improvement. Fourteen houses were constructed according to Draft Standard for Radon Resistant Building Construction in 1992 and twelve

houses in 1993. The data sets were analyzed statistically by the SAS program. However, the research results from the prior studies were not organized in a way that people could access them easily.

### Radon Information Is Not Well Organized or Accessible

There have been many research projects on radon problems. Research results have been published in journals and conference proceedings. However, the radon knowledge has not stored or organized properly. If these research findings and the ongoing projects' findings were saved on a computer, people could share them more easily. In addition, these facts could be transformed into a knowledge base which could be utilized to aid in decision making. Therefore, radon information should be saved on effective computer programs that will benefit users financially and timely.

### Objective of Work

Based on the investigation of previous research findings and the UF project results, the Radon Information System (RIS) was developed. It is designed to assist radon information retrieval, consulting and problem diagnosis. Also, RIS emphasizes on radon resistant construction methods for preventing radon intrusion.

Object-oriented databases in conjunction with an expert system were established in RIS. The databases were based on

intensive experiments from previous research and the Environmental Protection Agency's methods and standards. New house construction regulations, procedures, scheduling, cost estimation, and materials used were included in the system. Graphical construction procedures of mitigation systems and a potential radon index were also incorporated into the system. The user-friendly RIS is capable of assisting builders, contractors, homeowners, and researchers in obtaining suggested information for decision making.

#### Scope of Work

A literature review was conducted on methods of constructing of radon resistant houses. The information was then transferred into computer knowledge bases. The review focused on the construction methods used for preventing radon intrusion. Previous work reviewed consisted of radon sources and radon movement in soil, house ventilation rates and pressure differentials from indoor to subslab. Recent work reviewed consisted of evaluation of the efficiency of improved slab construction, construction costs, crack study, house ventilation rates, pressure differentials from indoor to subslab, and subslab depressurization systems. The results of the various investigations were compared to similar research in the past to investigate the cause and effect relationship between building characteristics and radon entry. The collected data from the literature were analyzed statistically. The results of this investigation

and findings from previous research were incorporated into computer knowledge bases. In addition to literature review, the following experimental work were conducted: floor crack study, pressure differentials tests, and tube length effect on radon reading tests.

### Outline of Chapters

Chapter 1 through Chapter 3 are the background information of radon from previous research findings. These findings are precious because they give guidelines and comparisons for the recent research. Chapter 4 is the analysis of UF research results. Chapter 5 describes the most recent mitigation methods. Based on Chapter 1 through Chapter 5, the important findings and necessary information are transformed into computer programs and are described in Chapter 6. A brief description of each chapter is as follows:

Chapter 1 is the overview of the whole research. Chapter 2 discusses the radon risks in health and its causes and sources. The definition of radon measurement units, radon prevention events, radon decay chain and radon entry mechanism that affect radon entry are discussed.

Radon entry related subjects in substructures (from slab to soil) and superstructures (from slab and above) are all detailed in Chapter 3. Important subjects in substructure include soil radium content, soil permeability, and soil moisture content. Slab cracks, building materials,

housing water and indoor radon are the key subjects in superstructures.

Chapter 4 discusses the data obtained from New House Evaluation Program (NHEP) research projects. The data were analyzed statistically. In addition, two experiments, effectiveness of tube length on radon readings and pressure changes on radon concentrations, are discussed.

The up-to-date construction methods in preventing radon intrusion are introduced in Chapter 5. Subslab depressurization methods are all detailed in steps.

Chapter 6 discusses the applications of computer aided design for radon knowledge consultation. A radon information system is developed for assistance in radon problems.

Chapter 7 contains the conclusions and recommendations for future research.

## CHAPTER 2 RADON RISK IN HEALTH AND ITS CAUSES

### Introduction

People exposed to high radon concentration will most likely get lung cancer. The potential risk of exposure is discussed in this chapter. The position of the governmental agencies toward radon assessment is outlined. The cause of radon damage is also introduced.

### What Is Radon?

Radon (Rn-222) is the decay product of uranium. It is a radioactive, odorless, colorless, and naturally-occurring gas. It can contribute to significant damage to respiratory tissue when there is prolonged exposure to elevated concentrations of the gas. Constant exposure to high concentration of radon gas may cause lung cancer. Figure 2.1 illustrates the mechanism of radon damage to lung tissues.

### Potential Radon Exposure Risks

The significance of the estimated health effects from radon daughter exposure to the bronchial epithelium is

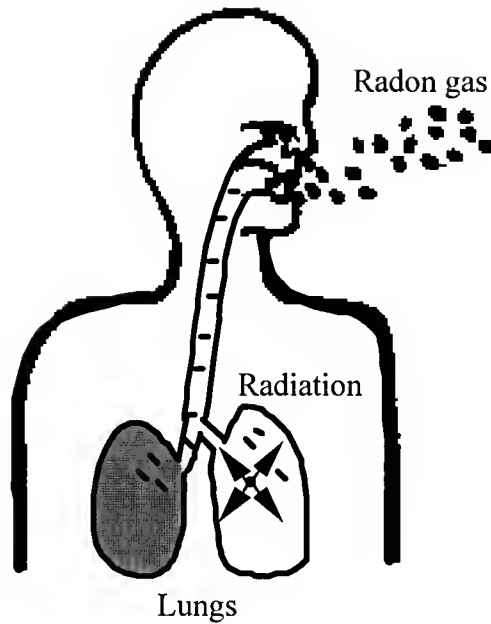

Figure 2.1 Radon Gas Damage Mechanism

compared to the corresponding health effects to other parts of the body. The proportional dose to other organs can be estimated by first considering the ratio of bronchial epithelium dose to alveolar dose. Table 2.1 shows the relative dose to each organ in comparison with the dose to the critical tissue, which consists of the basal cells of the bronchial epithelium. Dose to this tissue is often referred to as the tracheo-bronchial or T-B dose, according to the International Commission on Radiological Protection's (ICRP) respiratory tract model. The proportional doses to other organs are given as fractions of the T-B dose, for the condition where the body is in equilibrium with the radon

containing atmosphere. The T-B dose effect or risk of concern from radon daughter exposure is lung carcinoma. Since lung cancer has such a high mortality rate, it is assumed that morbidity for this dose effect is equivalent to mortality. Morbidity does not equal mortality for the corresponding dose to other organs. However, the relative doses to other organs are insignificant when added to the risk from T-B dose [Johnson 1973, p.31-33].

Table 2.1 Organ Dose Ratios and Absolute Risk

Organ	Organ to T-B dose ratio <sup>1</sup>
Bronchial epithelium	1.0000
Alveoli	0.0291
Liver	0.0013
Gonads	0.0009
Bone	0.0005
Bone marrow	0.0011
Kidneys	0.0066
Blood	0.0026
Muscle (soft tissue)	0.0007

Modified from [Johnson 1973, Table 8]

---

<sup>1</sup> Ratio of organ dose to T-B dose for conditions where the body is in equilibrium with the radon containing atmosphere.



Viel observed a statistically significant positive correlation between myeloid leukaemia mortality in adults (AML) and radon exposure [Eatough and Henshaw 1994]. This positive correlation with radon exposure is in agreement with similar observations at country level for AML in England and Wales for myeloid leukaemia in England. Radon as a risk factor for tumors, melanoma and kidney cancer is unclear. Further studies are needed to determine the radon risks.

#### Chronological Studies and Statements of Radon Risks

The radon problem did not received serious attention until the early 1980s. Radon gas is one of the most dangerous environmental pollutants. Radon risks have been reviewed by the Agency for Toxic Substances and Disease Registry, the Centers for Disease Control, the EPA, EPA's independent Science Advisory Board, the International Commission on Radiological Protection (ICRP), the National Academy of Sciences (NAS), the National Cancer Institute (NCI), the National Institute for Occupational Safety and Health (NIOSH) and the Surgeon General (SG). Each of these parties have reached consistent conclusions about the health

threat of radon exposure [HR 1994, p.12]. A chronology of major events is listed in Table 2.2.

The United States General Accounting Office (GAO) had testimony on the radon contamination reduction in houses in 1988. The testimony concluded that federal agencies involved with housing have responded differently to radon hazards. The overall federal housing response to the radon problem has been fragmented and been on small scale. The Congress should bring greater attention to the radon problem and order federal agencies to take more responsibilities about the radon issue [GAO 1988].

A hearing was held in 1990 on federal efforts to promote radon testing. This hearing provided a closer look at the radon problem and directed the funding and research guidelines [HR 1990]. The House Representative bill (HR) 2448 amends Title III, "Indoor Radon Abatement", of the Toxic Substances Control Act (ASCA). It requires the EPA Administrator to establish a mandatory performance and proficiency program for radon products and services [HR 1993, p.45]. The Administrator will make available to the public a list of those measurements and mitigation products which have met minimum performance criteria. In addition, it

Table 2.2 Major Radon Studies and Statements

Year	Agent	Statements
1986	EPA	1. Released "Citizen's Guide" on Radon. 2. Estimated 5,000 to 20,000 deaths annually. Action Level of 4 pCi/L.
1987	ICRP	ICRP report concluded that radon poses a greater cancer risk than assumed by EPA.
	NIOSH	Reported "significant health risks". Occupational standard: 1 WLM/year <sup>2</sup> .
1988	NAS	1. NAS report (BIER IV) found greater risks than previously assumed by EPA. 2. Based on miners studies, estimated potential lung cancer risk. 3. Recognized the difference between mining and domestic environment: remains unsolved.
	EPA	A new estimate of 8,000 to 43,000 deaths annually. Averaged 21,600 deaths.
	SG	Issues "A national health problem" that estimates thousands of deaths each year.

<sup>2</sup> One Working Level Month (WLM) per year is approximately equivalent to 4 pCi/L.

Table 2.2 Continued

Year	Agent	Statements
1991	NAS	Based on a comparison between mines and homes, estimates 30% reduction in homes compared to the first report.
	EPA	Completed national residential radon survey. Revised its estimate from 1.29 to 1.25 pCi/L.
1992	EPA	<p>1. EPA &amp; CDC issue a revised "Citizen's Guide" to radon.</p> <p>2. Estimates radon causes 7,000 to 30,000 deaths annually, average of 14,000 deaths.</p> <p>3. EPA's SAB reviews the revised EPA risk estimate and concluded "a solid, well-documented and defensible central estimate."</p>
	ATSDR	Concludes that "even conservative estimates suggest radon in one of the most important causes of death." Reports that 14% of all current cases of lung cancer could be attributable to radon.
1993	ICRP	A draft ICRP report finds the risks of radon exposure to be essentially the same as estimated by EPA and CDC in 1992. Action level at 5 pCi/L.
1994	NCI	Estimates 15,000 deaths from lung cancer each year; approximately 10% of all lung cancers.
	NAS	Recommends a re-analysis of the health risks associated with radon based on the accumulation of new evidence. The re-analysis includes multi-disciplinary models for radon carcinogenesis.

Modified from [HR 1994, p.12-14]

requires the Administrator to establish user fees on persons manufacturing or importing devices, or offering services covered by the performance and proficiency program.

There are four major tasks of HR 2448:

- 1) examine existing public awareness programs concerning radon;
- 2) act as a coordinating body for the donation of resources to assist in programs and strategies to raise outlets to increase radon awareness;
- 3) encourage media outlets to increase radon awareness;
- 4) evaluate the accuracy and effectiveness and assist in the update of such programs and strategies.

In the "Radon Awareness and Disclosure Act of 1994," the HR 2448 amends Title III of the Toxic Substances Control Act (15 U.S.C. 2661 et Seq.) to improve the accuracy of radon testing products and services, to develop a strategy to identify and reduce exceptionally high indoor radon levels, to promote and facilitate the testing and mitigation of vulnerable premises, to promote radon resistant construction in high radon areas, and to create a commission to promote increased public awareness of the health threats of radon exposure [HR 1994, p.11].

Radon and Liability

There have been several law involving radon problems. In Wayne Vs. TVA 730 F.2d 392 (5th Cir. 1984), cert denied, 496 U.S., 1159 (1985) homeowners brought product liability and negligence action against a phosphate slag producer whose slag was used to make concrete bricks for the construction of their homes. The verdict was in favor of defendants, holding that homeowners' claims were barred by the Tennessee Statute of Limitations applicable to product liability actions; in Robles Vs. Environmental Protection Agency 484 F.2d 843 (4th Cir. 1973) a homeowner sued the EPA to get results of a radioactive survey and the names and addresses of those owning homes exceeding EPA safety guidelines. The circuit court judge held that information gathered by EPA and relating to homes where uranium tailings had been used for fill was not exempt from disclosure; in Nobel Vs. Marvin E. Kanze, Inc., Civ. No. 02428, at 1 (Montgomery County Court of Common Pleas, Pa. 1983) the homeowner sued a contractor after finding radon entering through a crack in the ventilation system.

In the Nobel case, the homeowner sued for damages including expenditures of money and time to detect the

source of the radon gas, the cost of mitigation for high radon levels, repair and other expenses after mitigation [HR 1990, p.157].

Most real estate professionals and mortgage bankers do not require radon tests thereby leaving themselves and their stockholders open to actions on negligence and liability theory. Without a well-structured and phased plan to test structures for radon, homebuilders, realtors, bankers, construction companies and homesellers will face a significantly worse position relative to liability and negligence litigation in the long run. Congress and the Administration should be aware of the basis for expected tort action on radon. It is essential to have federal regulation to save litigation costs.

#### Radon Decay Chain

Radon is formed directly from the radioactive decay of Radium (Ra). The original source is Uranium (U). After a series of decays, Rn ( $^{222}\text{Rn}$ ) is formed and becomes the most serious decay product of Uranium. The decay flow chart of Uranium is illustrated in Figure 2.2. Radon has three major isotopes:  $^{222}\text{Radon}$ ,  $^{219}\text{Radon}$ , and  $^{210}\text{Radon}$  which are the

Uranium and Its Decay Sequences

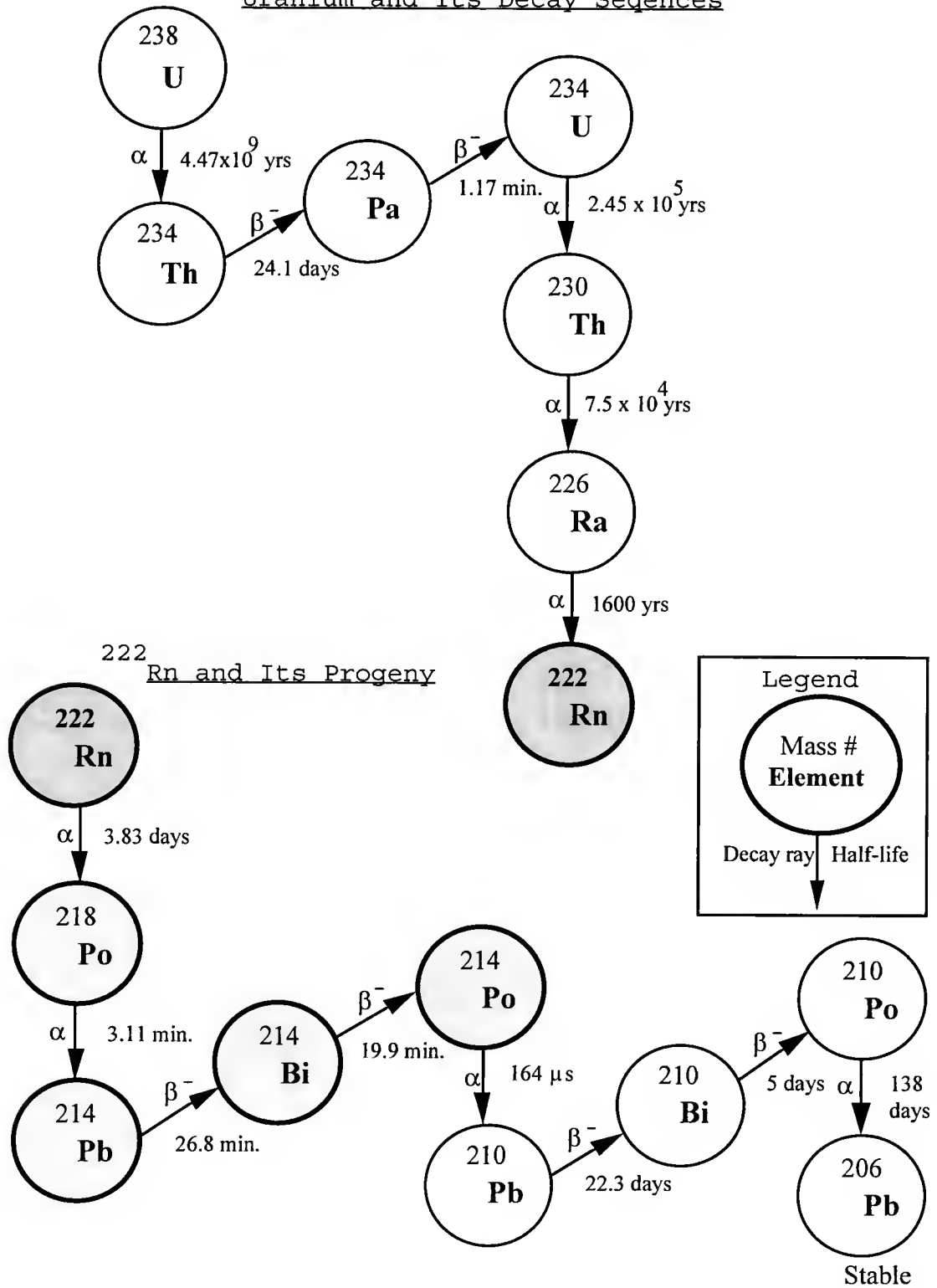

Figure 2.2. Decay Flow Chart of Uranium



most abundant in nature. The half-lives of the three isotopes are illustrated in Table 2.3 Modified from [Lao 1990].

Most radon comes from soil or rocks and enters into houses through cracks or penetrations. The traveling time is the critical factor of radon progeny entry. Therefore, the half-life of  $^{219}\text{Rn}$ , and  $^{210}\text{Rn}$  are both less than one minute and they are less likely to enter the house before they decay. However,  $^{222}\text{Rn}$  has chances of seeping into the house. Therefore, radon refers to  $^{222}\text{Rn}$  in general. One should be aware that the progeny of  $^{222}\text{Rn}$  (from  $^{218}\text{Po}$  to  $^{210}\text{Pb}$ ) all have half-lives less than 30 minutes. If inhaled, they are most likely to decay to  $^{210}\text{Pb}$  before removal by lung clearance mechanisms. The properties of radon progeny are shown in Table 2.4 [Lao 1990, Qu 1993].

#### Radon Damage Mechanism

The short-lived radon progeny could be harmful if inhaled because these elements could eject energy from  $\alpha$  or  $\beta$  particles. For example, the energy ejected from a  $^{218}\text{Po}$  atom disintegrating at the lung tissues deposits 7.7 Mev of ionizing energy in the tissue. The damage to lung tissues

Table 2.3 Radon Isotopes and Their Half-lives

Isotope	Half-life
$^{222}\text{Rn}$	3.83 days
$^{219}\text{Rn}$	55 seconds
$^{210}\text{Rn}$	4 seconds

Modified from Lao [1990]

Table 2.4 Properties of Radon Progeny

Nuclide	Radiation ray	Half-life	Potential $\alpha$ Energy/atom (Mev)
$^{222}\text{Rn}$	$\alpha$	3.825 days	4.06
$^{218}\text{Po}$	$\alpha$	3.11 min.	13.7
$^{214}\text{Pb}$	$\beta^-$	26.8 min.	7.7
$^{214}\text{Bi}$	$\beta^-$	19.9 min.	7.7
$^{214}\text{Po}$	$\alpha$	164 $\mu\text{sec.}$	7.7

Modified from Lao [1990], Qu [1993]

caused by the ionizing radiation of  $\alpha$  particles is measured in units of the  $\alpha$  energy. Internal irradiation by  $\alpha$  particles is believed to be the cause of radon-induced lung cancers. Because the penetration power of an  $\alpha$  particle is very poor, it loses virtually all its energy at one point in the lung tissue. The  $\alpha$  particles that are stopped by soft tissues deposit a large number of ions within a few cell diameters. This could kill a cell or cause mutation [Lao 1990, p.13].

#### Radon Measurement Units

The measurement units of radon concentration ( $^{222}\text{Rn}$ ) and radon progeny are pCi/L and Working Level, respectively.

#### Radon Concentration

Radon concentration is measured in pCi/L or Bq/m<sup>3</sup>. Curies (Ci) was named after Marie Curie (1867-1934) and Pierre Curie (1859-1906). The conversion factors are listed below

$$1 \text{ Bq} = 1 \text{ disintegration/second}$$

$$1 \text{ Curie (Ci)} = 3.7 \times 10^{10} \text{ Bq}$$

$$1 \text{ pCi} = 0.037 \text{ Bq}$$

$$1 \text{ pCi/L} = 37 \text{ Bq/m}^3$$

### Radon Progeny

Working Level (WL) is the unit for measuring the concentration of radon decay products. It is equivalent to  $1.3 \times 10^5$  Mev of potential  $\alpha$  energy from the short-lived progeny per liter of air. In addition, one WL is in balance with exactly 100 pCi/L of  $^{222}\text{Rn}$ . The definition of WL is illustrated in Table 2.5 [Lao 1990, p.14]. According to Table 2.5, the total potential  $\alpha$  energy per 100 pCi/L is approximately  $1.3 \times 10^5$  Mev.

Table 2.5 Definition of Working Level

Element	No. of atoms per 100 pCi/L of $^{222}\text{Rn}$	Potential $\alpha$ energy per atom (Mev)	Potential $\alpha$ energy per 100 pCi/L of radon (Mev x $10^5$ )
$^{218}\text{Po}$	977	13.7	0.134
$^{214}\text{Pb}$	8,585	7.7	0.661
$^{214}\text{Bi}$	6,311	7.7	0.486
$^{214}\text{Po}$	0	7.7	0
Total			1.281

### Radioactive Decay

The time rate of change of a radioactive material is defined as  $N$  (number/m<sup>3</sup>). The probability per unit time that a nucleus will decay is defined as  $\lambda$  which is independent from any known physical or chemical process. The first order differential equation is derived as [Lao 1990],

$$-dN/dt = \lambda N dt$$

$$\ln(N) = - \lambda t + C \quad (2-1)$$

Boundary conditions: at  $t=0$ ,  $N=N_0$ , Plug in (2-1)

$$C = \ln(N_0)$$

$$N(t) = N_0 e^{-\lambda t} \quad (2-2)$$

When  $t = T/2$ ,  $N = 1/2 N_0$ ,

where  $T/2$  is the time period of a radioactive material to decay to half its mass through the radioactive decay process.

Plug in (2-2)

$$T/2 = \ln 2 / \lambda \quad (2-3)$$

The half-life of a decay product can be calculated from equation (2-3). For example, the decay constant for <sup>222</sup>Rn is 0.00755 (h<sup>-1</sup>), the half-life of <sup>222</sup>Rn is

$$\begin{aligned}
 T/2 &= \ln 2 / (0.00755) \\
 &= 91.81 \text{ hours} \\
 &= 3.83 \text{ days}
 \end{aligned}$$

### Decay Relationship between Parent and Daughter

The relationship of  $^{222}\text{Rn}$  with its decay product  $\text{Po}$  is formulated as [Al-Ahmady 1994]

$$\begin{aligned}
 dN_{\text{Po}}/dt &= \lambda_{\text{Rn}} N_{\text{Rn}} - \lambda_{\text{Po}} N_{\text{Po}} \\
 &= \lambda_{\text{Rn}} N_{\text{Rn}}^0 e^{-\lambda_{\text{Rn}} t} - \lambda_{\text{Po}} N_{\text{Po}}
 \end{aligned} \tag{2-4}$$

where  $N_{\text{Rn}} = N_{\text{Rn}}^0 e^{-\lambda_{\text{Rn}} t}$ , at  $t = 0$ .

Rearrange equation (2-4) as follows,

$$dN_{\text{Po}}/dt + \lambda_{\text{Po}} N_{\text{Po}} = \lambda_{\text{Rn}} N_{\text{Rn}}^0 e^{-\lambda_{\text{Rn}} t} . \tag{2-5}$$

Solving for the homogeneous solution for equation (2-5),

$$\begin{aligned}
 dN_{\text{Po}}/dt + \lambda_{\text{Po}} N_{\text{Po}} &= 0 \\
 N_{\text{Po}} &= C e^{-\lambda_{\text{Po}} t}
 \end{aligned}$$

Assume that the particular solution for equation (2-5) is

$N_{\text{Po}} = K e^{-\lambda_{\text{Rn}} t}$ , plug in equation (2-5),

$$K (-\lambda_{\text{Rn}}) e^{-\lambda_{\text{Rn}} t} + \lambda_{\text{Po}} (K e^{-\lambda_{\text{Rn}} t}) = \lambda_{\text{Rn}} N_{\text{Rn}}^0 e^{-\lambda_{\text{Rn}} t}$$

$$K (\lambda_{\text{Po}} - \lambda_{\text{Rn}}) = \lambda_{\text{Rn}} N_{\text{Rn}}^0$$

$$K = \lambda_{\text{Rn}} N_{\text{Rn}}^0 / (\lambda_{\text{Po}} - \lambda_{\text{Rn}})$$

$$\text{Therefore, } N_{pO} = C e^{-\lambda_{pO} t} + [\lambda_{Rn} N_{Rn}^O / (\lambda_{pO} - \lambda_{Rn})] e^{-\lambda_{Rn} t}. \quad (2-6)$$

Boundary conditions: when  $t=0$ ,  $N_{pO}=0$ . Solving equation (2-6),

$$C = - \lambda_{Rn} N_{Rn}^O / (\lambda_{pO} - \lambda_{Rn}).$$

Substitute C back into equation (2-6), then

$$N_{pO} = [\lambda_{Rn} N_{Rn}^O / (\lambda_{pO} - \lambda_{Rn})] (e^{-\lambda_{Rn} t} - e^{-\lambda_{pO} t}) \quad (2-7)$$

$A_{pO} = \lambda_{pO} N_{pO}$ , where  $A_{pO}$  is the Activity rate (numbers/sec.  $m^3$ ). When  $t = t_m$ ,  $A_{pO}$  reaches maximum. Where  $t_m$  is the time of maximum activity. To find  $t_m$ , let  $dA_{pO}/dt = 0$ .

$$[\lambda_{Rn} N_{Rn}^O / (\lambda_{pO} - \lambda_{Rn})] [-\lambda_{Rn} e^{-\lambda_{Rn} t_m} + -\lambda_{pO} e^{-\lambda_{pO} t_m}] = 0$$

$$t_m = \ln(\lambda_{pO} / \lambda_{Rn}) / (\lambda_{pO} - \lambda_{Rn}) \quad (2-8)$$

By re-arranging this equation,

$$\lambda_{pO} N_{pO} / (\lambda_{Rn} N_{Rn}^O) = [\lambda_{pO} / (\lambda_{pO} - \lambda_{Rn})] [1 - e^{-(\lambda_{pO} - \lambda_{Rn}) t}] \quad (2-9)$$

$$\text{When } t \rightarrow \infty, \lambda_{pO} N_{pO} / (\lambda_{Rn} N_{Rn}^O) \cong \lambda_{pO} / (\lambda_{pO} - \lambda_{Rn}) \quad (2-10)$$

Transit equilibrium activity concentration is balanced when the ratio of daughter to parent activity is constant.

Special case, if

$$d_{T1/2} \ll P_{T1/2}, \quad d = \text{daughter}, \quad p = \text{parent}, \quad \text{then}$$

$$\lambda_d \gg \lambda_p.$$

Therefore, equation (2-10) becomes

$$\lambda_{Po} N_{Po} / (\lambda_{Rn} N_{Rn}^O) = 1. \quad (2-11)$$

This is the secular equilibrium special case of transient equilibrium when the daughter and parent activities are equal.

For example,  $T_{1/2} (Ra) = 1600$  years,  $T_{1/2} (Rn) = 3.83$  days,

$$\lambda_{Po} = 1.18 \text{ E-6 /day}, \lambda_{Rn} = 0.181 \text{ /day}$$

$$\lambda_{Po} N_{Po} / (\lambda_{Rn} N_{Rn}^O) = 0.181 / (0.181 - 1.18 * \text{E-6}) \cong 1.000007$$

$$\text{and } t_m = \ln(0.181 / 1.18 \text{ E-6}) / (0.181 - 1.18 \text{ E-6}) \cong 66 \text{ days.}$$

### Summary

This chapter discussed radon risks, radon related legal issues, and radon sources. Radon decay chain and its damage mechanism were also presented.



## CHAPTER 3 RADON TRANSPORT IN STRUCTURES

### Introduction

This chapter focuses on substructure and superstructure parameters to the radon entry. The important issues in substructures are soil and soil radium content. Soil has been found to be the key factor that affect radon intrusion. Radium content in soil and its transport is introduced. The major factors affecting indoor radon levels in superstructures are concrete slab type, building materials, house water and pressure-driven flow.

### Review of Literature

Since the mid-1970's, the electric power industry has been working on ways to give customers better choices for controlling the quality of their indoor environment. This work focused in part on evaluating the effects of building design and systems operations on indoor radon levels [Harper et al. 1988].

House radon concentrations depend on a variety of factors (e.g., radon availability in the soil, interaction of building and soil, weather forces affecting radon entry). Research studies, sponsored by the Electric Power Research

Institute (EPRI) and the Tennessee Valley Authority (TVA), and principally conducted by GEOMET Technologies, Inc., and Oak Ridge National Laboratory, have examined the effects of siting, building design and space condition operations on indoor radon levels. These studies also examined the effectiveness of different radon and progeny control approaches. Soil is the principal source of indoor radon in single-family houses in the United States [Nero and Nazaroff 1984]. Pressure-driven flow is a principal means by which soil gas enters houses; it is expected to be the predominant source of radon in houses with elevated concentration. There are three principal causes of basement depressurization [Garbesi and Sextro 1989]: thermal differences between indoors and outdoors, wind loading on the building superstructure, and imbalanced building ventilation.

Soil-gas entry due to basement depressurization has been experimentally demonstrated by Nazaroff et al. (1987). Entry pathways have been assumed to be penetrations, gaps, or cracks in the building substructure. A demonstration of a previously neglected pathway for soil-gas entry into houses is pressure-driven flow through permeable, and below-grade building materials. Such a flow, distributed over the wall area, could occur via porous building materials or via a network of small cracks. If this pathway is ignored in the modeling of soil-gas entry into buildings, predictions of the soil-gas entry rate could be substantially too low [Garbesi and Sextro 1989].

### Research Subjects

This research focused on the relationship of the construction to the radon intrusion. The analysis was based on the research projects of New House Evaluation Program of Florida. The research analyzed all aspects of building behavior from substructure to superstructure. The subjects investigated are illustrated in Figure 3.1. Major subjects researched include:

- 1) Soil
- 2) Concrete slab
- 3) Penetrations (plumbing, joints)
- 4) Building materials
- 5) Pressure differentials (HVAC systems, ventilation, wind, temperature)

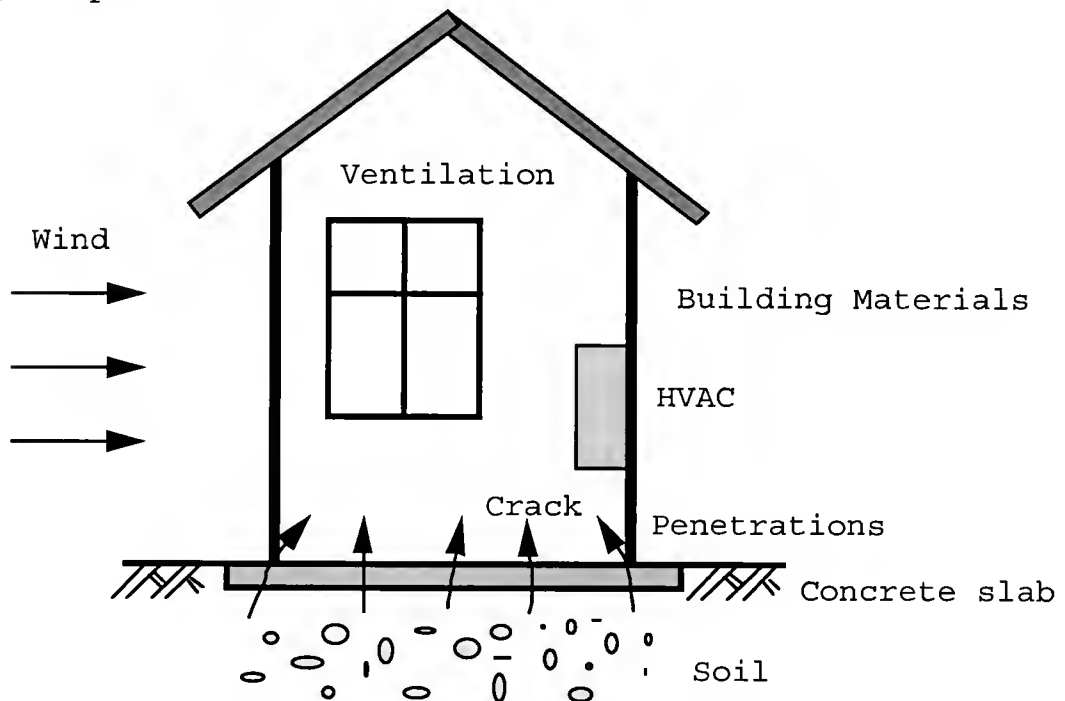

Figure 3.1 Major Research Subjects

### Sources that Contribute to Indoor Radon

The sources that contribute to indoor radon concentration are:

- 1) Soil
- 2) Building Materials
- 3) House water
- 4) Ambient air

### Radon Transport in Substructures

Radon in soil will be discussed in detail and the related movement parameters will also be discussed. Soil radium content, radon emanation coefficients, and soil permeability will be introduced.

### Radon in Soil and Its Movement

For most houses with high indoor radon concentrations, soil is the principal source of radon [Nero and Nazaroff 1984; Nazaroff et al. 1988; Revzan and Fisk 1992]. Soil radon gas is estimated to contribute 85% - 90% of indoor radon among the sources [Clarkin and Brennan 1991]. Since a large percentage of radon source comes from soil, the main focus of the radon source is on the soil of the building site. Figure 3.2 illustrates the radon sources and the factors that affect their entry. Considering the sources that affect the concentrations of soil radon, the radioactive decay of radium is the primary contributor.

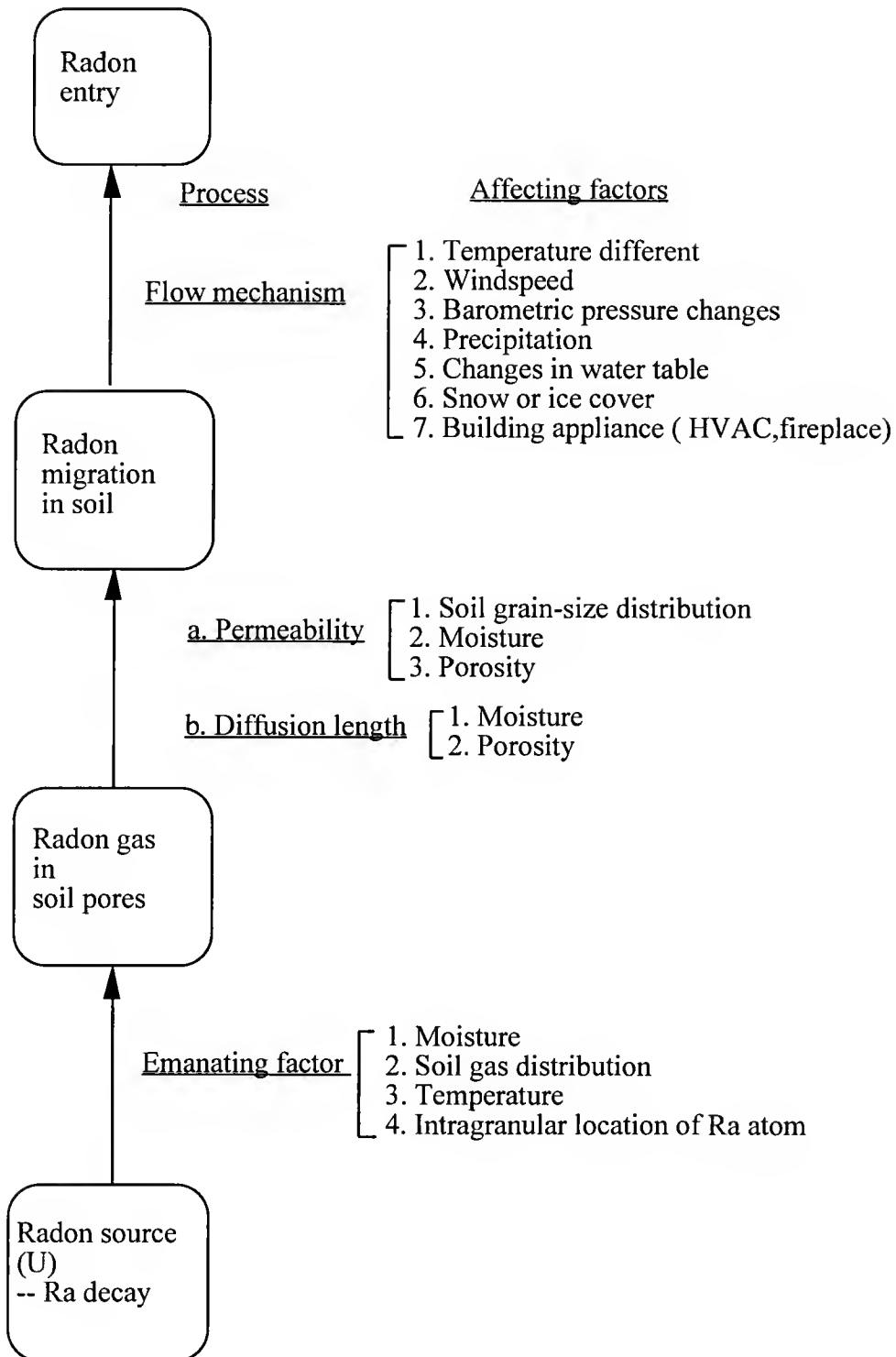

Figure 3.2 Soil Gas Radon Entry Mechanism and Affecting Parameters

Elevated soil radium concentrations may cause higher rates of radon generation in the soil air; therefore, the soil radium concentration should be considered in the foundation soil.

### Radon Emanation Coefficients

The fraction of radon generated from soil grains that enters the pore volume of the soil is the emanation coefficient. Emanation coefficients for soil range from 0.05 to 0.7 [Rogers et al. 1989; Nazaroff 1992]. The emanation coefficients for 48 Florida soil samples averaged 0.33 [Rogers and Nielson 1991a, p.3-3]. Moisture content has been demonstrated to have a large effect on the emanation coefficient of radon from uranium ore tailings, concrete, and soil [Nazaroff 1992, p.143]. The emanation coefficient is much lower if the source material is dry rather than moist. Moisture content dependence to emanation coefficient is presented in Figure 3.3 [Nazaroff 1992, Fig.5]. The figure suggests that high moisture content soil has higher emanation coefficient than low moisture content soil. The reason for this could be a lower recoil range for radon in water than in air. Temperature changes have been found to be a factor in determining the radon emanation coefficient. When soil temperature was increased from 5<sup>0</sup>C to 50<sup>0</sup>C, the emanation coefficient increased by 55% [Nazaroff 1992].

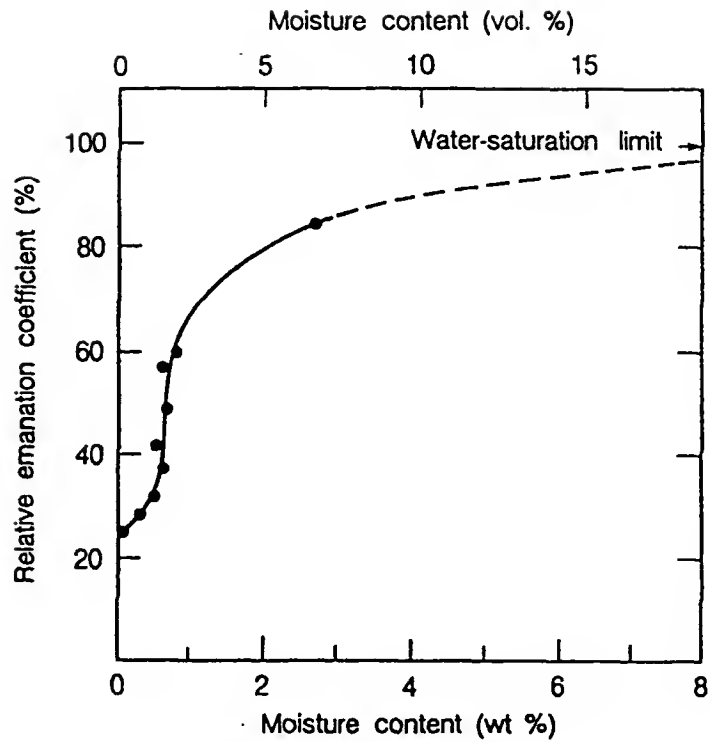

Figure 3.3 Effect of Moisture Content on the Relative Radon Emanation Coefficient [Nazaroff 1992]

However, the soil temperature does not change much. This effect could be neglected.

#### Indoor Radon Prediction Model

Pressure driven from the house due to appliances, thermal gradients, heating and air conditioning systems or winds, pull the soil air with its radon gas into the house.

The movement of the air depends on the soil permeability. The higher the soil permeability, the easier

the gas moves. An indoor radon prediction model was made by Mose [Mose et al. 1992] using soil radon and soil permeability<sup>1</sup>. The prediction model was successful for most of the houses in northern Virginia and southern Maryland. The prediction model is shown in Figure 3.4. Mose et al. (1992) proclaimed that their estimates are very useful for indoor radon prediction. However, the indoor radon concentration is affected by more factors than their model took into account. Therefore, more parameters should be taken into account in order to have a better prediction. The parameters, such as soil permeability, soil radium content and foundation type are crucial to the indoor radon elevation.

### Soil Permeability

Soil permeability is associated with soil porosity, moisture, and grain-size distribution. A theoretic equation for soil permeability for laminar flow in saturated coarse grained soils is described as [Scott 1969]:

$$K = [1/(5.0 S_s^2)] [n^3/(n-1)^2] [\gamma_w/\eta]$$

Where

$$k = K (\eta/\gamma_w)$$

$$K = \text{Hydraulic conductivity (m/hour)}$$

$$k = \text{Soil permeability (m}^2\text{)}$$

---

<sup>1</sup> The permeability of this case is defined as inch/hour which is the velocity of the fluid flows through the soil.



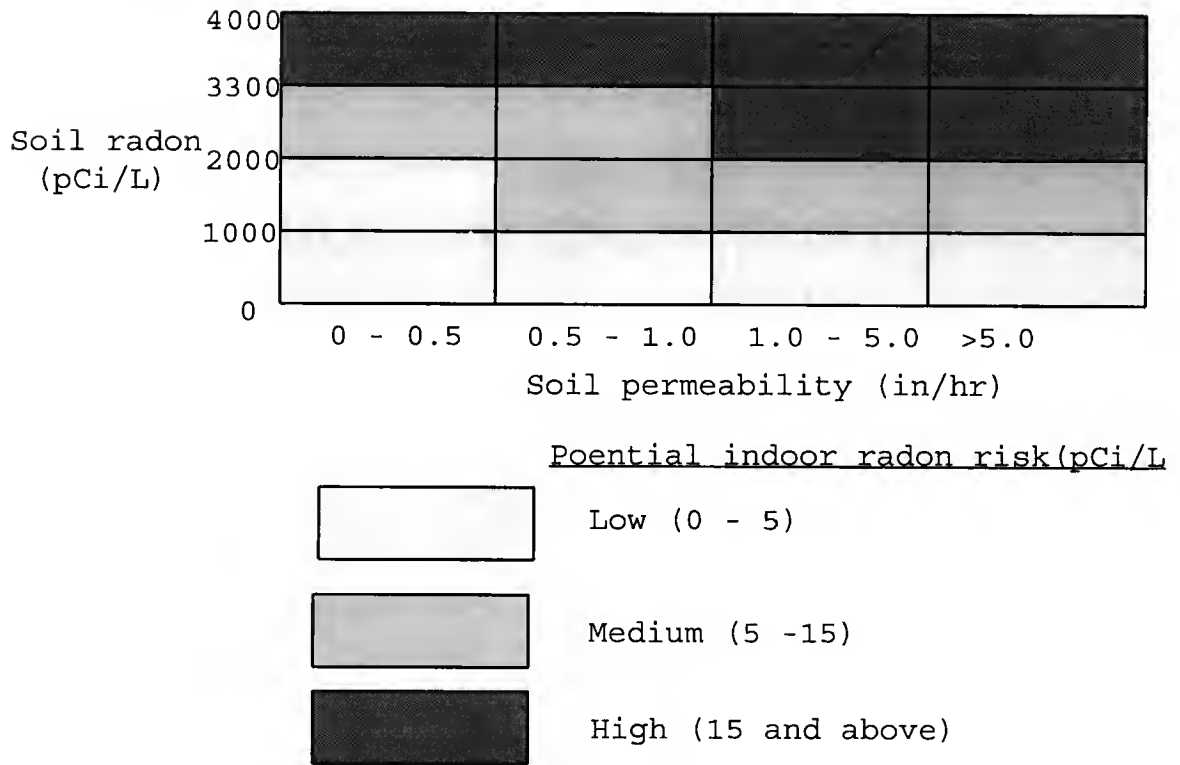

Figure 3.4 Indoor Radon Prediction by Using Soil Radon<sup>2</sup>  
[Mose et al. 1992]

<sup>2</sup> The permeability (in/hr) of this case is sometimes defined as hydraulic conductivity.

$S_s$  = Surface area of the particles in unit volume  
of the solid material

$n$  = porosity

$\gamma_w$  = unit weight of water

$\eta$  = viscosity of water.

For sandy soils, Hazen suggested that the approximate value of  $K$  is given by [Scott 1969]:

$$K = C (D_{10})^2$$

where

$C$  = a coefficient varying between 0.01 and 0.015

$D_{10}$  = effective size of soil in mm

An empirical model for predicting soil gas permeability is defined as [Rogers and Nielson 1991b]:

$$k = (p/110)^2 d^{4/3} \exp(-12 m^4)$$

where

$k$  = soil gas permeability ( $\text{cm}^2$ )

$p$  = total soil porosity (dimensionless)

$d$  = arithmetic mean grain diameter (cm),  
excluding >#4 mesh material

$m$  = moisture saturation fraction (dimensionless).

The radon diffusion coefficient factor is derived by Rogers [Rogers and Nielson 1991b] as:

$$D = 0.11 \exp(-6mp - 6mp^{14p})$$

where

$D$  = radon diffusion coefficient ( $\text{cm}^2/\text{sec}$ ).

Subslab soils are ranged from coarse sand to fine clay. The smaller particle silts and clays have higher ambient

moisture contents and generally lower permeability and diffusion coefficients; therefore, radon gas in the soil air cannot move as easily to the entry points onto the house. Both K and D decrease significantly with moisture for  $m > 0.5$ . Soil moisture content is controlled in large part by precipitation. Fine grained soils such as silts and clays, have higher moistures under normal environmental conditions. Therefore, they have lower K and D values than sands. Radon gas does not move as easily through them. However, for a specified radon entry rate into a house, the silts and clays can have higher radium content because more of the radon gas is held in the soil.

The permeability and diffusion coefficients are closely related, and exhibit similar trends with soil type, degree of compacting and moisture. Thus the permeability coefficients can be used to specify soil conditions in a way that also includes the effect of diffusion. The average soil permeability of soils is listed in Table 3.1 [Yegingil 1991, p.181].

Clay and silt have very low permeabilities and the radon entry rates are very low compared to the sandy soils. Revzan and Fisk (1992, p.42) observed that when the soil permeability is less than  $10^{-12} \text{ m}^2$ , the soil-gas velocity at the openings in the basement shell is low and diffusion is the principal means of radon entry. In this case, the radon entry will be dependent on the concentration of the soil gas radon.

Table 3.1 Soil Permeability

Soil type	Soil permeability (cm/sec)	Relative Degree of Permeability
Gravel	$10^{-3} - 10^{-6}$	High
Clean sand	$10^{-5} - 10^{-8}$	High
Silty sand	$10^{-6} - 10^{-10}$	Medium
Silty	$10^{-8} - 10^{-12}$	Low
Glacial tilt	$10^{-9} - 10^{-15}$	Low
Marine clay	$10^{-12} - 10^{-15}$	Very low to practical impervious

Modified from Yegingil [1991]

### Radon Flows through Different Soil Layers

In construction practices, a layer of fill earthen materials is placed between the concrete slab and the top of the natural soils. The natural soils may consist of several layered soils. The layered soils have their own properties. However, the top layer has the most significant impact to the radon entry. However, if the second layer of soil contains high radium and the top soil has high permeability, elevated radon concentrations may occur.

Rogers and Nielson (1991b) measured indoor radon levels often exceeding 10 pCi/L, even though the radium concentrations in the sandy soils immediately beneath the slab are less than 1 pCi/g. Measurements of subslab radon are several thousand pCi/L, indicating that the radon is mainly coming from soils in the Hawthorn Formation. Soils in the Hawthorn Formation have radium concentrations ranging from 5 to 30 pCi/g in this area. Soil gas radon is a reliable indicator of a potential radon problem which was suggested by many researchers [EPA 1991].

Different layers have different soil permeabilities and which is one of the important factors that affects radon entry. Soil permeability of different layers may be calculated as follows [Todd 1980]:

$$\begin{aligned} Q_x &= K_1 I Z_1 + K_2 I Z_2 + K_2 I Z_2 \\ &= I (K_1 Z_1 + K_2 Z_2 + K_2 Z_2) \end{aligned}$$

$$\text{Also, } Q_x = K_x I (Z_1 + Z_2 + Z_2)$$

where

$Q_x$  = Flow rate in the x direction ( $m^2/s$ )

$K_i$  = Hydraulic conductivity (m/s)

$I$  = Hydraulic gradient

$Z_i$  = Depth of Layer  $i$  (m)

$K_x$  = Overall hydraulic conductivity in the x direction

$k$  = Permeability ( $m^2$ )

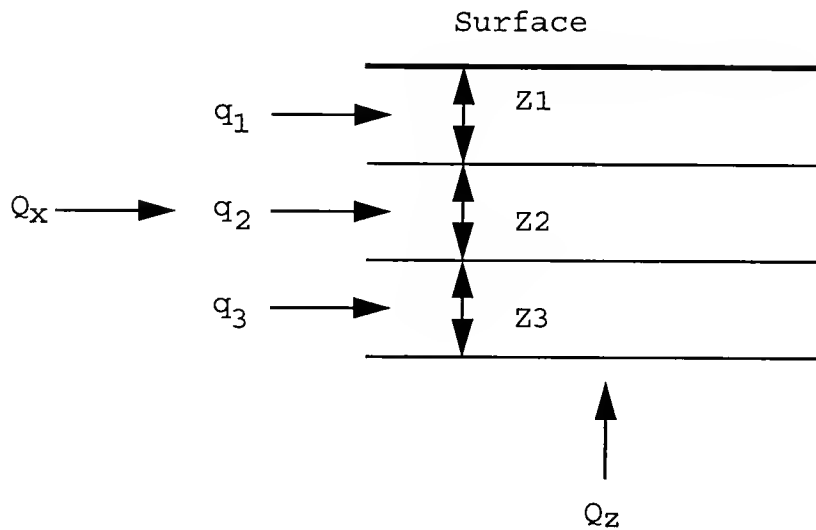

$\mu$  = Dynamic viscosity

$\rho$  = Fluid density

$g$  = Acceleration of gravity ( $m/s^2$ )

Therefore,

$$K_x = (K_1 Z_1 + K_2 Z_2 + K_2 Z_2) / (Z_1 + Z_2 + Z_2) \quad (3.1)$$

$$k = \frac{K \mu}{\rho g} \quad (3.2)$$

Assumption: Assume that equation (3.2) holds for gas.

Substitute (3.2) into (3.1),

$$k_x = (k_1 Z_1 + k_2 Z_2 + k_2 Z_2) / (Z_1 + Z_2 + Z_2) \quad (3.3)$$

In general form,  $k_x = \Sigma k_i Z_i / (\Sigma Z_i)$

$$\text{Similarly, } k_z = \Sigma Z_i / (\Sigma(Z_i/k_i)) \quad (3.4)$$

The ratio of  $k_x/k_z$  usually falls in the range of 2 to 10 for alluvium, but values up to 100 or more occur where clay layers are present [Todd 1980, p.81].

#### A Proposed Mitigation Method

Because the  $k_x/k_z$  ratios of soils are large, the horizontal movement of the soil gas radon is faster than vertical movement. According to this phenomenon, a radon reduction method is proposed. The proposed method is illustrated in Figure 3.5. There are two or more vertical two-inch PVC pipes needed connecting the perforated pipes. There is a slope of the perforated pipe for ease of gas movement. The pressure driven flow may dominate the diffusion movement of the radon gas; however, the perforated pipes could reduce the pressure differentials between subslab and indoor (so called pressure break). The perforated pipes can produce equivalent pressure between subslab and atmosphere.

In addition, the PVC pipes connect the shower water to the soil. The pipes discharge water into the soil and keep soil moisture content high, which could slow radon movement.

#### Soil Permeability in Different Depths

Soil permeability is affected by soil pressure. Figure 3.6 illustrates the soil permeability distribution under

different consolidation pressures [Hoddinott and Lamb 1990]. High pressure tends to reduce soil permeability.

Because of soil pressure, the deeper the soil the higher the pressure is. However, the soil pressure in the 10 feet range which we consider affecting indoor radon elevation, does not change drastically. However, the pressure differentials from indoor to outdoor has been proven to dominate the transport of the soil gas radon [Lao 1990].

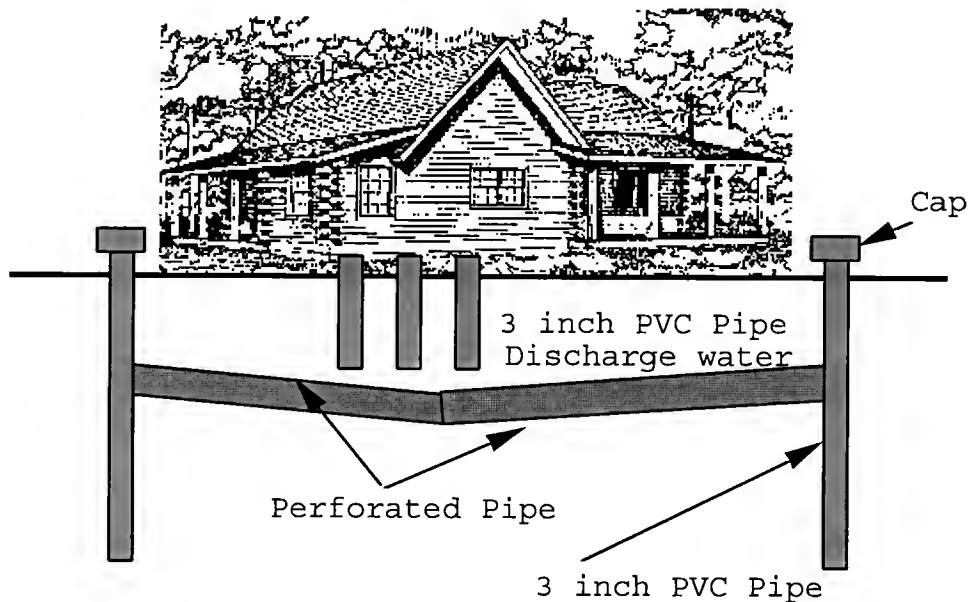

Figure 3.5 Soil Gas Radon Mitigation by Perforated Pipe Systems



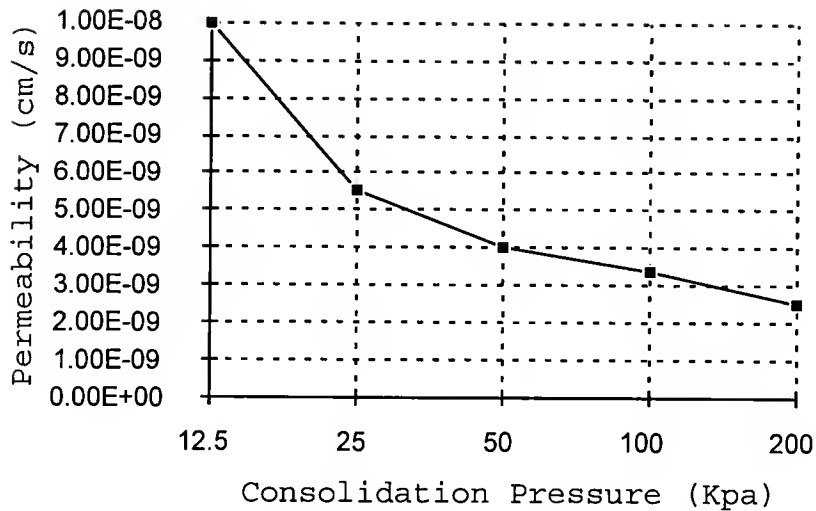

Figure 3.6 Permeability Distribution of Different Pressures

#### Radon from Geological Consideration

Many researchers have confirmed that the relationship between geology and indoor radon is complicated and dependent on climate, terrain, bedrock composition and soil permeability. Geology controls the chemical composition of the rocks and soils from which radon is derived. Climate exerts a strong control over the temperature and moisture content of soils, thus affecting radon emanation and physical and chemical weathering of the soils and rocks.

Indoor radon assessments often rely on factors such as bedrock geology or soil permeability to predict the potential of an area for radon. Rock types that are most likely to cause indoor radon problems include carbonaceous black shales, glauconite-bearing sandstones, certain kinds of fluvial sandstones and fluvial sediments, phosphorites,

chalk, karst-producing carbonate rocks, and so on. Rocks least likely to cause radon problems are marine quartz, and certain kinds of non-carbonaceous shales and siltstones, certain kinds of clays, silica-poor metamorphic and igneous rocks, and basalts. Mafic rocks are characteristically a poor radon source. Rocks such as aluminous and feldspathic gneiss, schist, and phyllite vary but are generally sources of moderate to high radon. Granites and sheared rocks are generally sources of very high radon [Gundersen 1993, p.IV1]. Figure 3.7 shows the average soil radon concentration distribution vs. indoor radon concentrations [Gundersen 1993, p.IV4].

The glacial lake deposits are composed of fine sand, silt and clay. A very high correlation between indoor radon and soil radon was found in Gundersen's research when the measurements were grouped by glacial deposit and the measurements were averaged. However, if the measurements were grouped by bedrock type the regression only yielded an  $R=0.21$ . Therefore, glacial deposits are better predictors of indoor radon and radon sources in soil than bedrock geology. Figure 3.8 illustrates the average indoor radon levels vs. soil radon concentrations [Gundersen 1993, p.IV5].

#### Geological Elevated Radon Summary

The rocks which the have highest uranium contents are

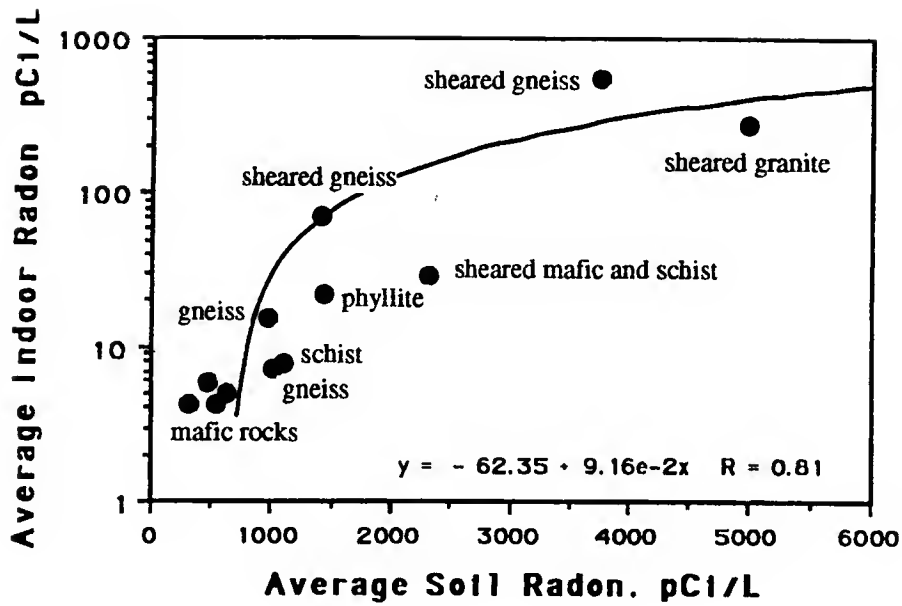

Figure 3.7 Average Indoor Radon Levels vs. Soil Radon Concentrations [Gundersen 1993]

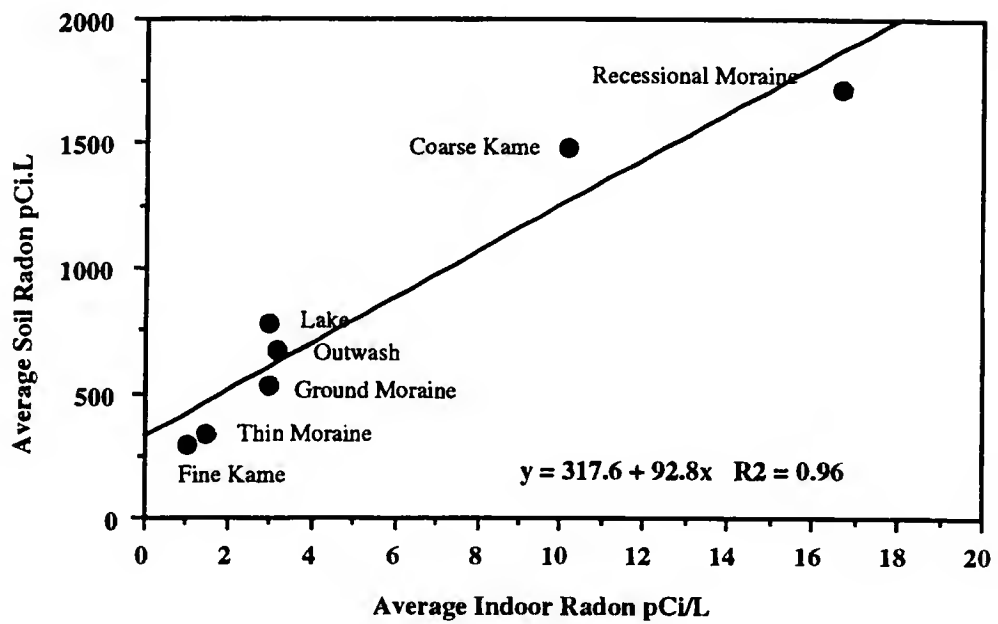

Figure 3.8 Average Indoor Radon Concentration vs. Soil Radon Concentration [Gundersen 1993]

certain types of granite, black (carbonaceous) shales, and phosphoric rocks. The common range of uranium concentrations is between 2 to 10 ppm with averages around 3 to 4 [Lao 1990].

Geological areas having granites with more than 10 ppm uranium could have a high radon potential. Uraniferous black shales usually have an average uranium concentration of up to 20 ppm. Phosphate rocks with 100 ppm uranium are very common. High-grade phosphates may be a significant source for elevated radon levels [Lao 1990, p.28].

#### A Generalized Geological Map for the State of Florida

A research performed by Otton (1993) shows that the geology of Florida is dominated by fluvial, deltaic, and marine sedimentary rocks. The older sedimentary rocks, mostly limestone and dolomite, are exposed in a structural high centered in Levy County along the western side of peninsular Florida. Younger sedimentary rocks occur throughout southern Florida, along the Atlantic coast, and coastal areas of the western panhandle. A generalized geology map is shown in Figure 3.9 [Otton 1993, IV-5].

Uraniferous phosphatic sediments occur in the Alachua Formation, the Hawthorn Group and Bone Valley Formation [Sweeney and Windham 1979]. Although only a few occurrences of uranium minerals have been described in Florida, where these unuraniferous phosphatic rocks are mapped, high

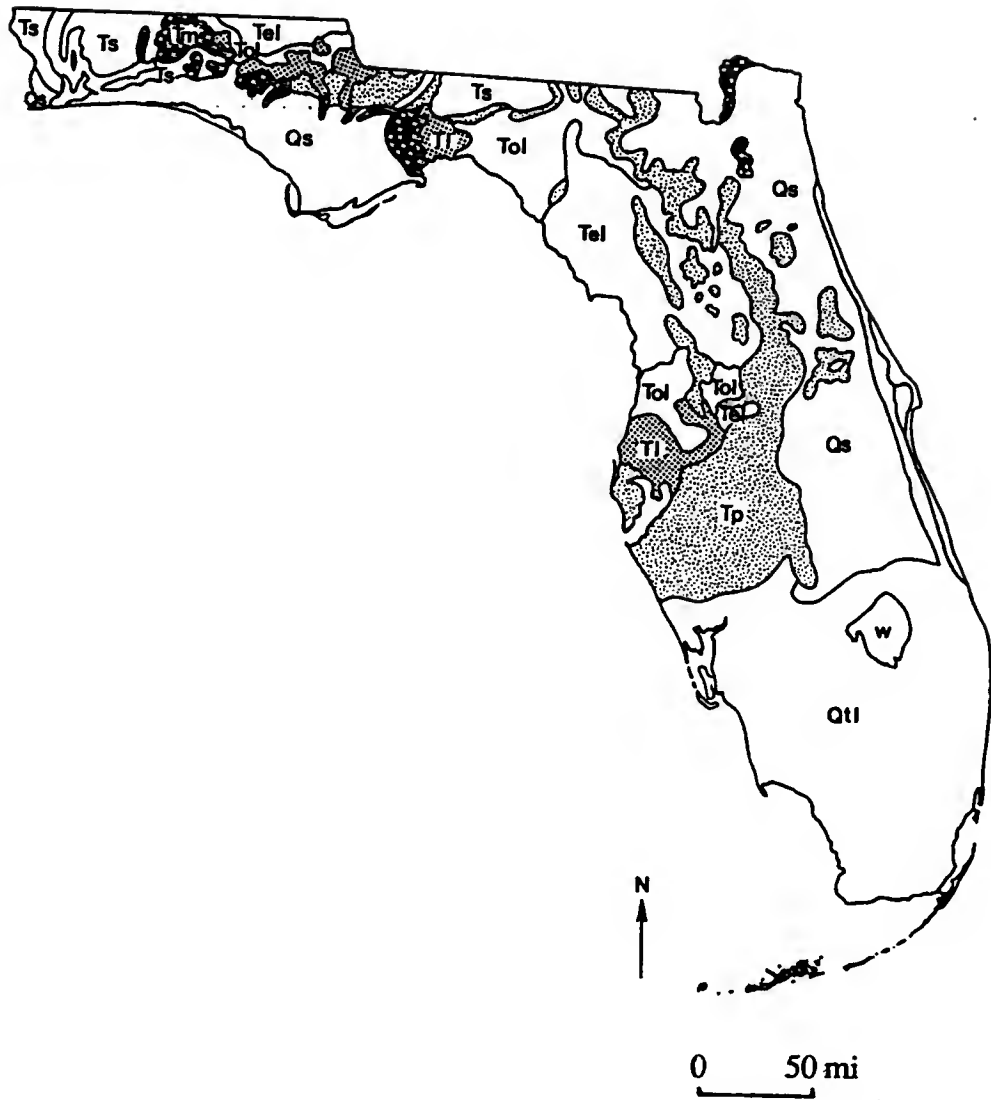

Figure 3.9 Generalized Geology Map of Florida [Otton 1993]

Legend of Figure 3.9

Type	Stratigraphic Unit	General lithology	Major lithologic unit
Qs	Surfical and terrace sands. Undifferentiated.	Quartz sands with varying proportions of silt, clay, organic material and carbonate.	Sand
Qtl	Lake Furt Marl, Miami Limestones, Key Largo Limestone, Anastasia Fort Thompson, Caloosahatchee, Tamiami Formation. Undifferentiated.	Fossiliferous limestone, maris and lesser amounts of sand and clay.	Limestone
Ts	Citronelle and Miccosukee Formation. Undifferentiated.	Clays and quartz sands with lesser amounts of silts and gravels.	Sand and clay
Tm	Chariton, Jackson Bluff, Red Bay, Yellow River, and Chipola Formation. Undifferentiated.	Shell maris, clays and quartz sands with minor limestones.	Marl and sand
Tp	Bone Valley, Alachua, Fort Preston and Hawthom Formation (Group). Undifferentiated.	Sands, silts and clays with lesser amounts of limestone, dolomite and phosphorite.	Phosphoric clay and sand
Tl	St. Marks, and Chattahoochee Formation. Undifferentiated.	Impure limestones with sand and lesser amounts of limestone, dolomite and phosphorite.	Limestone
Tol	Suwannee Limestone, Ducan Church Beds, Byram Formation and Avon Park Limestone. Undifferentiated.	Limestones which may be slightly sandy or dolomitic.	Limestone
Tel	Crystal River, Willston, and Inglis Formation Avon Park Limestones. Undifferentiated.	Fossiliferous limestones and dolomite	Limestone and dolomite

concentrations of uranium (up to a few hundred ppm) in near-surface soils and bedrock are known to occur. South Ocala is described to have this type of rocks [Espenshade 1985].

Soils containing a few tens to a few hundreds of ppm of uranium are likely to be strong sources of radon. Surface materials in southernmost Florida are composed mostly of peat, sand, and limestone. Sand, silt, shell, and clay are the primary surface materials along the Atlantic Coastal areas from Lee County to Pinellas County. Refer to Figure 3.10. Surface materials across most of the state are low in uranium content with most of the state showing less than 1.5 ppm equivalent uranium (eU).

A strip of land about 60 miles wide along the Atlantic Coastal margin extending from Jacksonville southward to Miami is almost entirely below 1.5 ppm. However, the highland areas in the north and north central part of the State generally range from 1.0 to 2.0 ppm eU.

Higher readings occur in an area underlain by phosphatic rocks that extends discontinuously from southern Polk County northward to southern Columbia County, including an area of a few hundred square miles averaging greater than 5.5 ppm eU. Dade County underlain by thin sandy soils

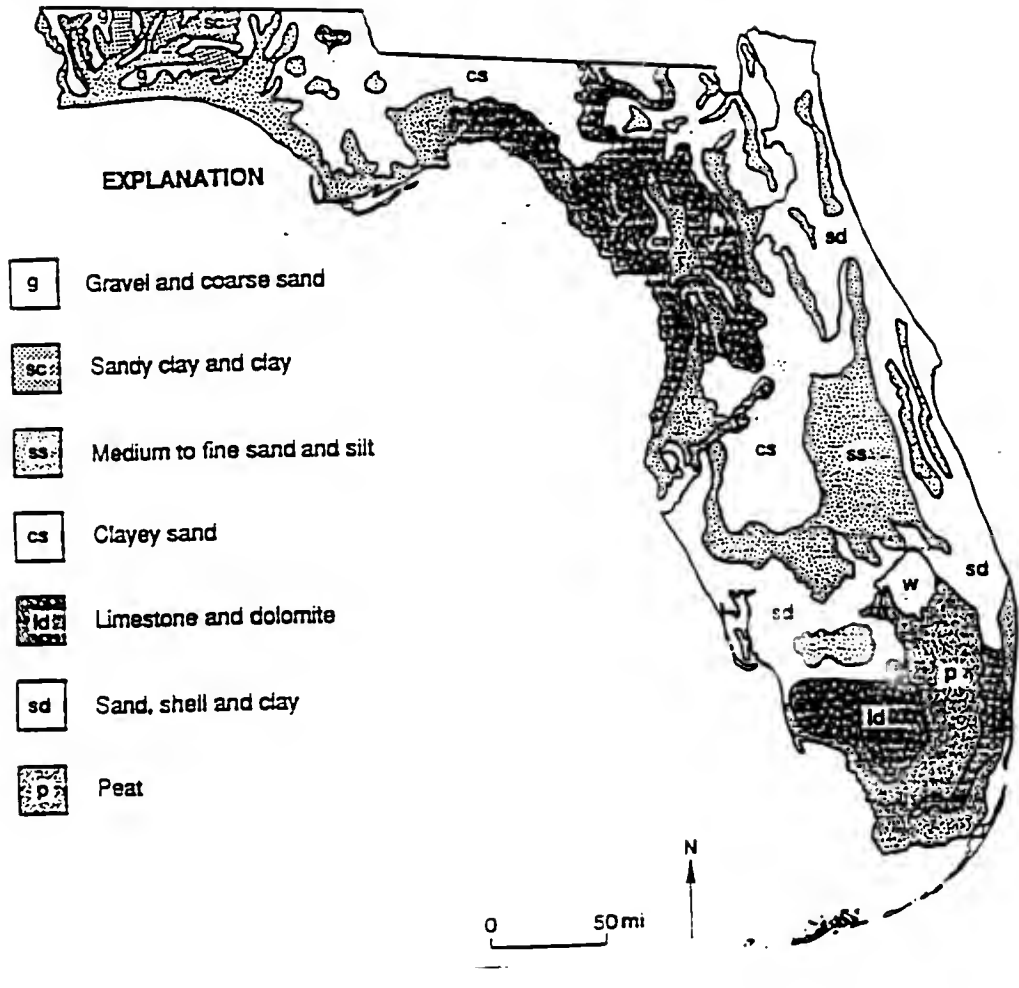

Figure 3.10. Generalized Surface Materials Map for the State of Florida [Otton 1993]



covering shallow limestone bedrock, has equivalent uranium values as high as 3.5 ppm.

#### Phosphate Region and Indoor Radon Levels in Florida

A study of the phosphate region of Florida which was investigated by Roessler et al. (1983) is shown in Figure 3.11. The indoor radon level of houses in Florida is shown in Figure 3.12 [DCA 1994]. Figure 3.12 shows the tested results of average indoor radon levels of the Florida houses. There is a similarity between these two figures; areas interpreted as highly phosphated have high indoor radon levels.

#### Summary of Radon Transport in Substructures

Radon sources are mainly from soils and rocks. The radon levels are affected by permeability, soil moisture content, radium content, and pressure differentials. Highly phosphated area have high indoor radon levels as demonstrated in Figures 3.11 and 3.12.

#### Radon Transport in Superstructures

The following sections will discuss the factors in superstructures that are significant to the elevation of indoor radon. These factors include concrete slab, building materials, house water, and pressure differentials. These

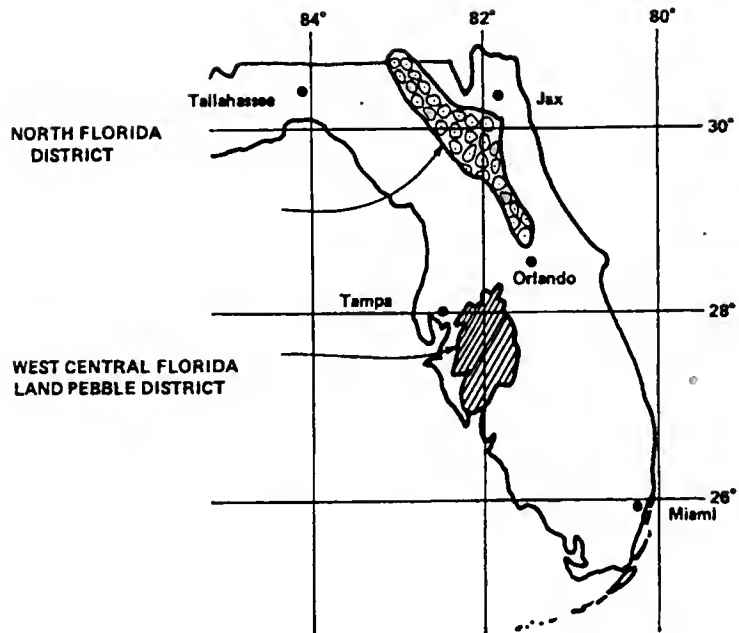

Figure 3.11 Phosphate Distribution in Florida [Roessler et al. 1983]

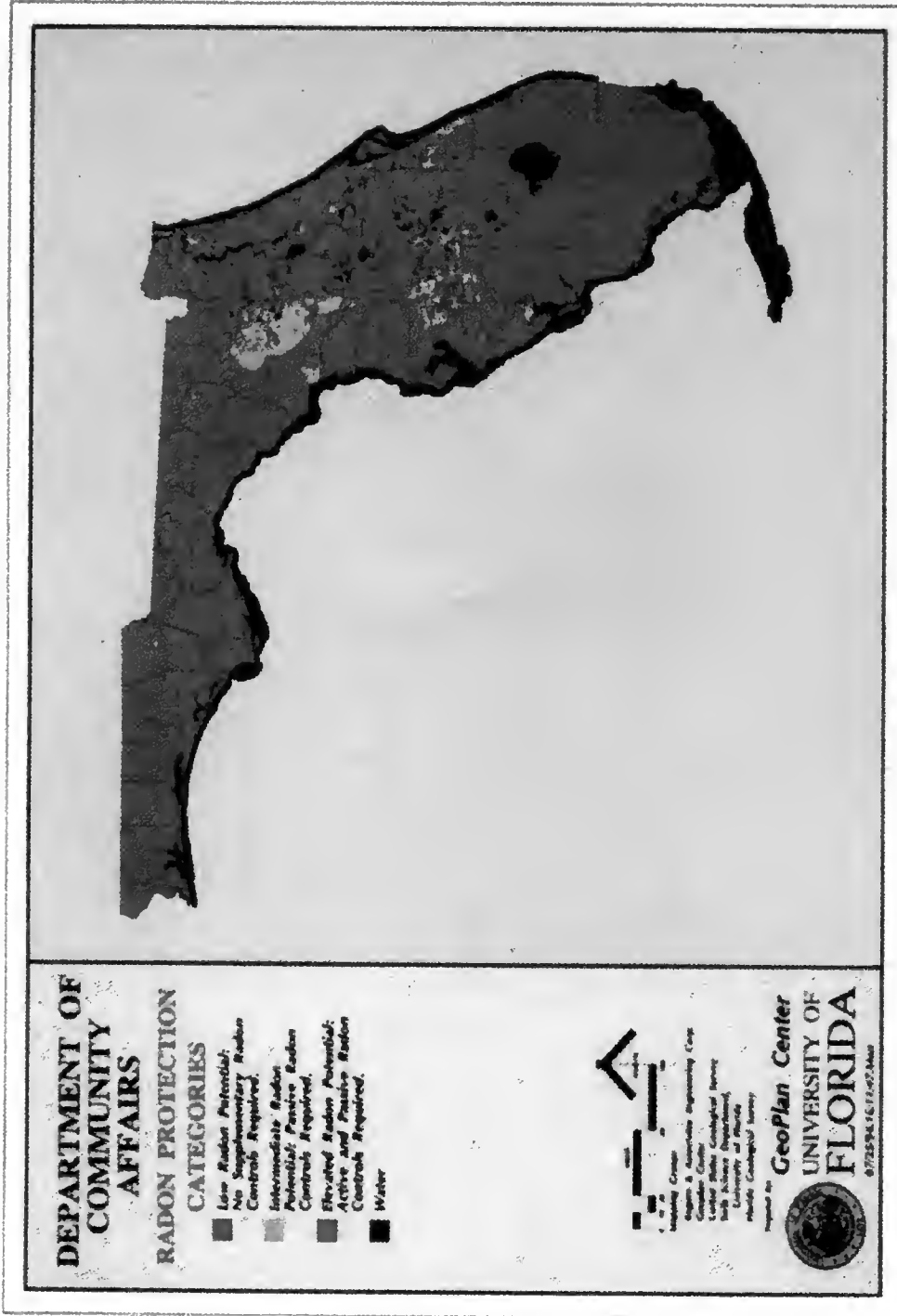

Figure 3.12 Indoor Radon Levels of Florida [DCA 1994], Radon Potential Levels: Color in Green: Low; Yellow: Moderate; Red: High; Blue: Water.

factors have been researched seriously in the FRRP research projects. The results and their interpretation will be discussed.

#### Radon Transport through Concrete Floor Slab

Radon gas can seep into houses because of the pressure-driven flow through concrete slab cracks, plumbing penetrations and wall-slab connections. Diffusion of radon from subslab soil through concrete floor slab and radium decay of concrete itself may contribute to the concentration of indoor radon. The ACRES (1978, p.5) report suggested radon diffusion from or through concrete cannot be a significant source of radon entry.

Tanner (1990) identified radon diffusion as a significant mechanism when foundation soil permeabilities are less than  $7 \times 10^{-12} \text{ m}^2$ . Subsequently, Rogers and Nielson (1990) investigated diffusion through concrete floors and the contiguous soil as a significant mechanism for radon entry for many soils under typical long-term average foundation pressure gradients. This paper characterizes the radon generating properties of Florida concretes. The parameters measured are the radium concentrations and emanation coefficients of Florida concretes and their constituents. The radon generation and transport through Florida residential concretes are examined for their contribution to indoor radon concentrations. The

paper also identifies the main properties of concrete performance that influence radon migration from the subsoil into dwellings. In addition, Loureiro et al. (1990) have compared theoretical diffusion and convection radon transport in soils to estimate conditions when diffusion is insignificant.

The diffusion coefficients as measured from the Florida concrete slabs by Rogers and Nielson (1992) range from  $1.8 \times 10^{-4} \text{ cm}^2 \text{ s}^{-1}$  to about  $4.6 \times 10^{-3} \text{ cm}^2 \text{ s}^{-1}$ . In general, the diffusion coefficient increases with water/cement ratio. The permeability of the concrete slab is very low and averages  $5.34 \times 10^{-12} \text{ cm}^2$ . This value falls in the permeability range of silt clay. Thus, the transport mechanism is mainly from diffusion. The radium and emanation are the source index of radon diffusion. The radium ranges from 1.0 pCi/g to about 2.4 pCi/g. The emanation coefficients averaged 0.07 which is very small.

The measurements in Florida by Rogers and Nielson (1992) showed radium concentrations averaged 1.52 pCi/g, and the average emanation coefficients of aggregates are less than 0.08, which is a very low emanation value; therefore, their radium contents are less important than the radium in cement components. Concrete with a radium content less than 2 pCi/g contributes less than 10 percent to the total radon entry in the example dwelling. The radon transport through the concrete slab by diffusion and radon diffusion from the

concrete slab itself have proven to be minor contributions to the indoor radon.

### House Water

Radon gas can be dissolved in cold water. As was experienced by the University of Florida research team when it rained one day before site screening, the reading was lower than usual and in some cases had extremely low readings. Radon can be dissolved in water and released in the air when showering, dishwashing, and washing clothes. It is estimated that 10,000 pCi/L of radon in water will contribute about 1 pCi/L of radon to the indoor air [Lao 1990, p.18].

Research also shows that using only well water presents a problem. For the houses using water from public utility systems, waterborne radon in general does not contribute significantly to the indoor radon concentration. Because the public water is supplied from treatment plants and stored in storage tanks, after it reaches the houses, most radon may have decayed already (half-life 3.8 days).

For those houses which have a problem with water radon, two cost-effective treatment methods that can be utilized to remove radon from water supplies [Lowry and Lowry 1988] are:

- 1) Granular Activated Carbon (GAC) Adsorption/Decay
- 2) Aeration.

In the first method (GAC), research shows that this

method is successful in reducing radon from over one million pCi/L to less than 500 pCi/L, for a 99.9% removal efficiency. The key to the effectiveness of GAC method is the adsorption/decay steady state that occurs for radon and its short-lived daughters.

The aeration has three major methods: diffused bubble, spray, and counter current packed tower. It has been verified that the diffusion bubble method reduced 250,000 pCi/L of radon to 50 pCi/L [Lowry and Lowry 1988]. The usage of the GAC or aeration will be determined by the capital and operation/maintenance (O&M) costs. It is summarized in Table 3.2.

For household supplies, the GAC method is the most economical alternative. However, with flows greater than 20,000 gpd, packed tower aeration is the most cost-effective method [Lowry and Lowry 1988]. Housewater may contribute a significant amount of indoor radon if the water radon level is high. Most high water radon levels are from wells; however, nowadays, the use of well water is insignificant in comparison to the use of municipal water supply.

#### Emanation from Building Materials

While radon emanation has been studied for more than two decades, the earlier studies suggested that construction materials were the most important source of indoor radon elevation. More recent studies have proved that radon

Table 3.2 Utilization and Costs of Water Radon Mitigation Methods

Supplies Flow (Gpd)	Method	Installation cost (\$)	O & M
Household 50-500	GAC	800	Negligible
Multi-unit & small community 500-20,000	Spray	2300	High
Municipal >20,000	Pack tower aeration	Vary	High

Modified from Lowry and Lowry [1988]

transport from the soil or rock adjacent to the building is the major factor. An emanation test was performed by Fleischer et al. (1984) and suggests that the local materials contribute much less radon per unit mass than do the geological materials that surround homes or that are used indoors for heat storage. Table 3.3 illustrates the average values of the radon emanation rates. Radon emanation depends strongly on temperature and relative humidity [Wu and Medora 1987].

It was found that radon emanation could be reduced when coatings were applied on the testing materials. The results showed that when Semi-glass ALKYD Enamel A40-w5 and Epoxy Paint were applied on the testing block, the emanation rates



Table 3.3 Radon Emanation Rates

Material	Emanation rates (atoms/gm-sec)
Soil	0.0065
Sand	0.0024
Brick	0.0012
Wallboard	0.00014
Stone	0.0012

Modified from Fleischer et al. [1984]

were reduced by 97.5% and 85%, respectively. However, this test was performed in a closed room which may not be realistic to the actual emanation rates.

Emanation rates for concrete, brick, and natural gypsum are 0.0009-0.0003, 0.00001-0.005 and 0.002-0.02, respectively [Morawska and Philips 1991]. It shows that gypsum has very high emanation rate in comparing to concrete and brick. In new construction, materials with high radium content, such as gypsum and phosphate should be avoided.

### House Ventilation

Ventilation is defined as the total rate at which outdoor air enters a house. Ventilation has three components [Nazaroff et al. 1988; Ward et al. 1993]:

1) Infiltration: uncontrolled leakage of air into a house which occurs through cracks, and penetrations in the

house envelope;

2) Natural ventilation: the flow of air into the house through open windows and doors;

3) Mechanical ventilation: forced supply or removal of air by means of blowers or fans.

### Ventilation Rates and Indoor Radon Concentrations

It is assumed that increasing ventilation decreases indoor radon concentration because the higher air change per hour (ACH) rate dilutes the indoor radon concentration. This phenomenon was proved in the UF research that in nearly all cases the general trend was that indoor radon and house ventilation rates are in opposite directions. Figure 3.13 illustrates the opposition between indoor radon concentration and house ventilation rate.

### Radon Entry Rate

Radon entry rate can be measured by measuring both radon concentrations and ventilation rates over the same time periods. The governing equation of the radon entry rate can be described as [Hintenlang et al. 1994a]:

$$dC/dt = [R-QC]/V - \lambda C \quad (3.5)$$

where  $c$  = indoor radon concentration (Bq/m<sup>3</sup>)

$\lambda$  = radioactive decay constant of <sup>222</sup>Rn

$Q$  = volumetric air flow rate through the structure  
(m<sup>3</sup>/s)

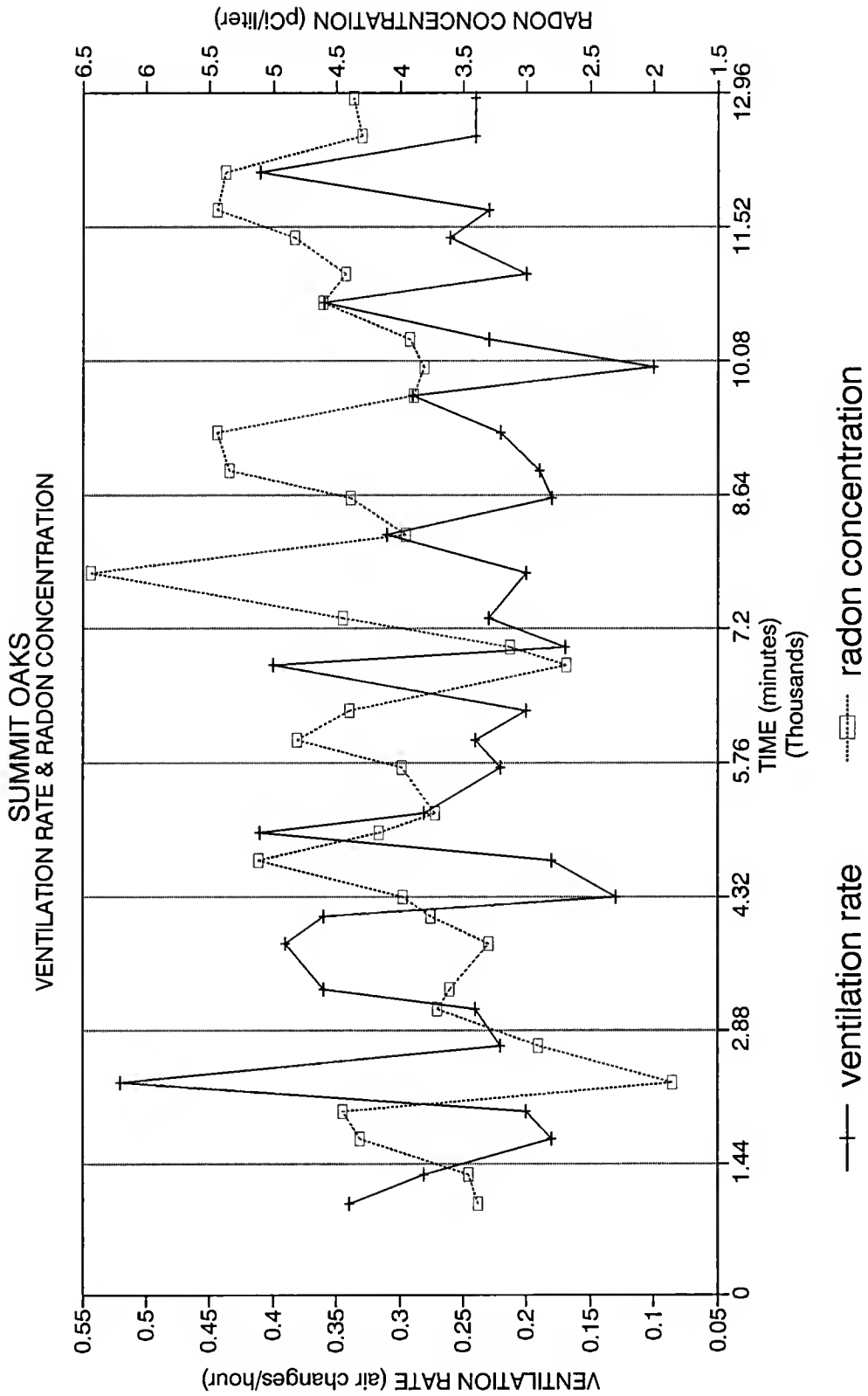

Figure 3.13 Indoor Radon Vs. House Ventilation Rate [Hintenlang et al. 1994a]

$R$  = radon entry rate (Bq/s)

$V$  = house volume ( $m^3$ )

$Q$  is related to the house ventilation rate by:

$Q = \lambda_v V$  with  $\lambda_v$  the house ventilation rate.

Equation 3.5 has the steady state solution:

$C = R/[Q + \lambda_v V]$

However, the truly steady state conditions are not achieved in houses because the ventilation rates are continuously varying. The solution of equation 3.5 can be solved numerically for a time interval,  $\Delta t$ . The discrete form for this solution is then:

$$\Delta C(t + \Delta t) = \{V^{-1} [R(t) - C(t) \lambda_v(t) V] - \lambda_d C(t)\} \Delta t,$$

rearranging this equation,

$$R(t) = [(C(t + \Delta t) - C(t))/\Delta t + \lambda_d C(t) + \lambda_v C(t)]V \quad (3.6)$$

By using this solution technique, radon entry rates were calculated as a function of time for each of the research houses. Radon entry rate with respect to time is shown in Figures 3.14. and 3.15. According to Figures 3.14 and 3.15, the calculated radon entry rates are relatively constant throughout the measurement period. Most houses exhibit variations between maximum and minimum entry rate no larger than a factor of two. The periodicity of the radon entry rate variations are similar to the periodicity of the

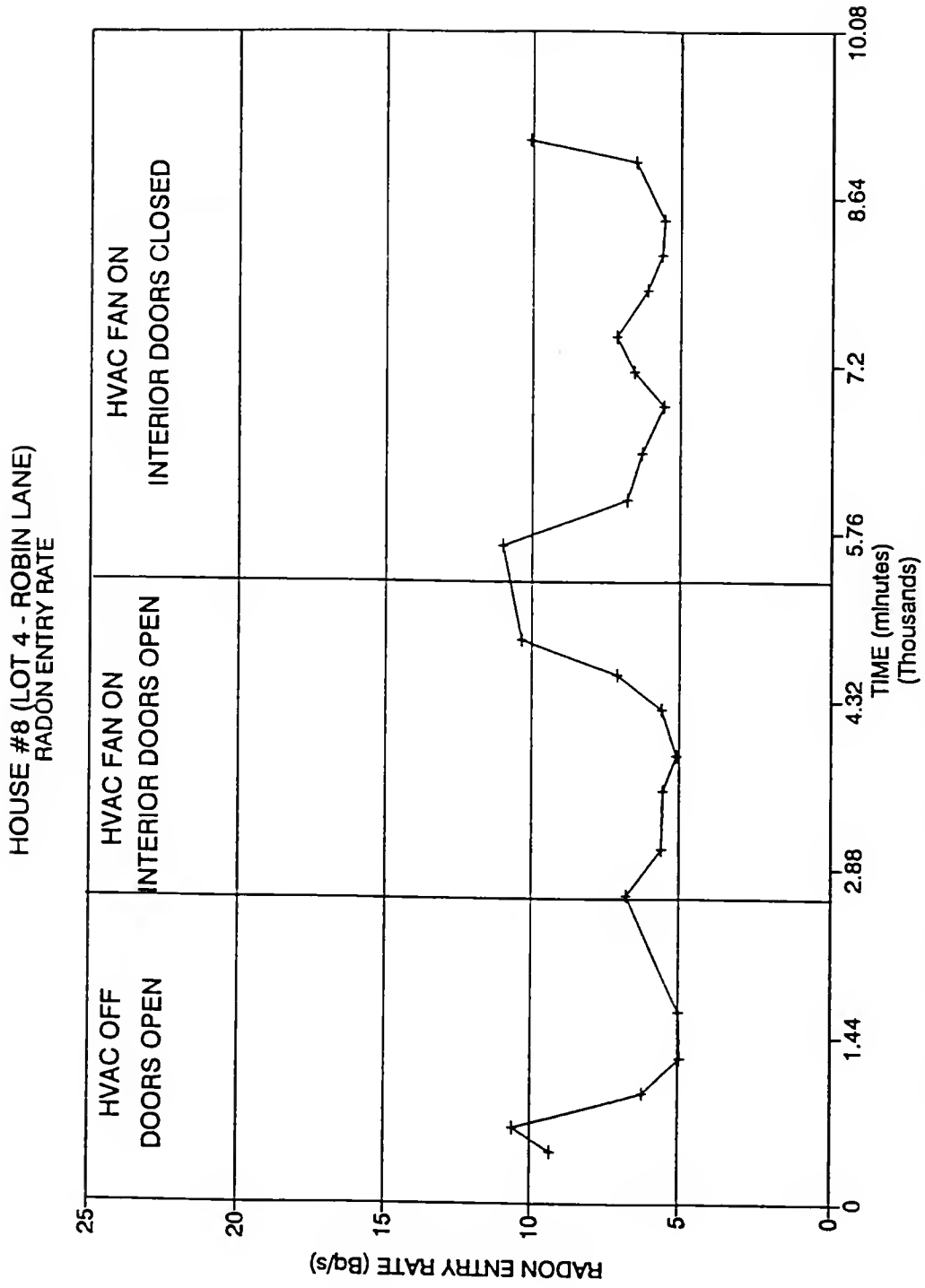

Figure 3.14 Radon Entry Rate for House "Robin Lane" [Hintenlang et al. 1994a]

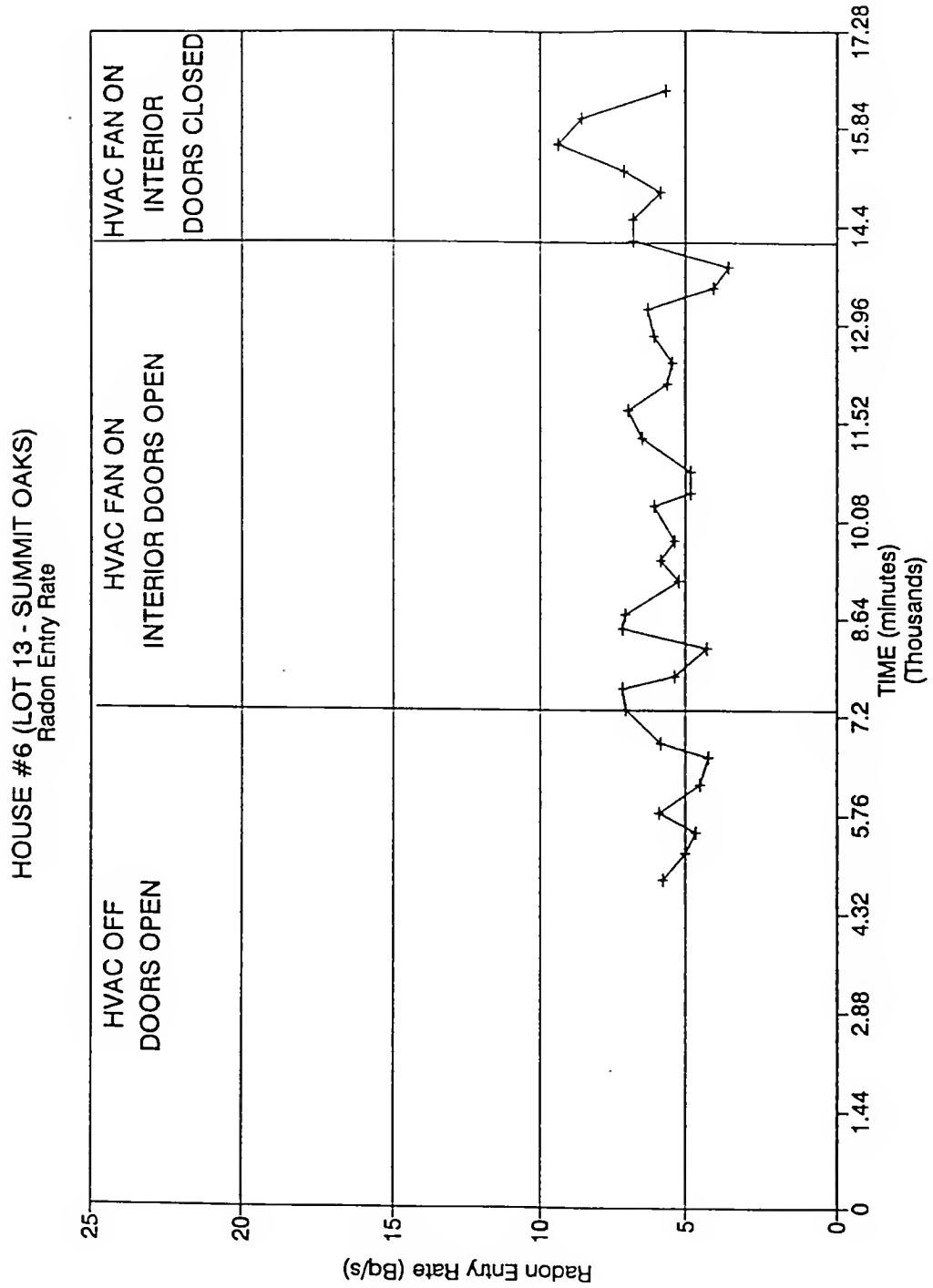

Figure 3.15 Radon Entry Rate for House "Summit Oaks" [Hintenlang et al. 1994a]

radon concentrations and ventilation rate. Besides the periodic variation, the entry rates for most houses remained relatively constant throughout the test. No significant variations of radon entry rate corresponding to changes of the HVAC operation configuration were observed period [Hintenlang et al. 1994a, p.114]. These results provide direct evidence that the operating configurations of the HVAC systems do not affect the radon entry rate in these structures. The average radon entry rates across the measurement periods for each of these houses are shown in Table 3.4. Table 3.4 demonstrates that all of the houses have similarly small entry rates even in the presence of indoor depressurization or pressurization. This result indicates that the passive radon barriers installed in these houses were effective in limiting radon entry into the structure's interior.

#### Pressure-driven Flow

One of the EPA's recent research projects was the feasibility study of basement pressurization using a forced-air furnace. The EPA's 2-year systematic study of three Princeton University research houses clearly demonstrates that radon entry rates depend directly on basement depressurization. The results also clarify the role of natural ventilation in reducing indoor radon concentrations. Natural ventilation is a simple way to reduce indoor radon

Table 3.4 House Radon Entry Data

House Number	Indoor radon (pCi/L)	Air Change Rate ( $\text{h}^{-1}$ )	Radon Entry Rate (Bq/s)	Radon Entry Flux ( $\text{Bq m}^{-2} \text{ s}^{-1}$ )
1	2.3	0.49	8.6	0.046
2	3.0	0.33	9.5	0.044
3	2.2	0.34	4.1	0.017
4	2.7	0.27	4.9	0.034
5	2.5	0.31	5.2	0.024
6	4.2	0.26	5.9	0.032
7	2.7	0.38	6.9	0.032
8	2.8	0.21	2.8	0.025
Average	2.80	0.32	5.99	0.032

Modified from Hintenlang et al. [1994a, p.115]

levels; however, until now, there has been no information on how much reduction to expect. The natural ventilation decreases radon levels in two ways:

- 1) by simple dilution;
- 2) by providing a pressure difference.

The pressure break reduces both depressurization and radon entry. In the Pennsylvania project, Radon Mitigation Branch (RMB) demonstrated that a typical forced-air furnace system could be installed to pressurize a basement to reduce radon entry. The system reduced radon levels from 19.3 to 1.5 pCi/L in summer conditions [EPA 1992].



Another technique was the application of small fans for active soil depressurization (ASD) in new houses. The EPA's proposed model standards for controlling radon in new buildings include placing a layer of aggregate and barrier under the slab. By meeting these standards and sealing the slab, it may be possible to use smaller fans than those now used for ASD systems in existing houses. Smaller fans cost less to install and operate, require less space, and may be quieter.

A third project was a simple model for describing radon mitigation and entry into houses. This model uses simplified assumptions about the distribution of radon entry routes and driving forces to relate indoor radon levels to soil characteristics. Under these assumptions, the model shows that:

- 1) soil permeability is the most important influence on indoor radon concentrations because soil permeability varies naturally by five to six orders of magnitude;

- 2) the area of the radon entry route is not very important;

- 3) 90 percent of the total soil gas flow occurs in a band surrounding the house with a width six times the depth of the basement;

- 4) because radon decays, only the volume of soil within a band, if the width is about two times the basement depth, actually contributes to indoor levels.

The most updated UF research is the Sub-Slab Depressurization (SSD) systems. This project was finished in December, 1994. The new house evaluation program was to develop standards to be adopted in future building codes and to develop and test new protocols for measurements for future research. The measurements include soil tests, soil permeability, soil characterization, pressure field extension, crack characterization, air infiltration and leakage, tracer gas testing, short term radon tests and long-term radon tests.

Pressure differences generated from the interactions between the indoor, outdoor and sub-structure area under different environmental and occupation conditions are responsible for elevated indoor radon concentrations.

Hintenlang and Al-Ahmady (1992) have verified experimental evidence that semi-diurnal pressure differential driven radon entry exists for a slab-on-grade structure built over low permeability soil. Mathematical treatments predicting the sub-slab air volume pressures and the pressure differentials across the slab have been correlated to the atmospheric tidal barometric pressure variations and are found to be responsible for significant increases in indoor radon concentrations [Al-Ahmady 1992, Hintenlang and Al-Ahmady 1992].

Al-Ahmady and Hintenlang (1994a) have also demonstrated that temperature induced pressure differences can be a significant influence on radon driving forces and

consequently the indoor radon concentrations under particular configurations associated with the utilization of the HVAC system [Al-Ahmady and Hintenlang 1994b]. The effects of air infiltration rates, that are governed by the differential pressure across the structure shell, on indoor radon concentrations can be attributed to the exchange and dilution of indoor radon with ambient air having much lower radon concentrations.

Pressure-driven flow has proven to be the major driving force of radon entry. However, UF research has found no evidence that suggests the radon entry rate correlates with across slab differential pressure [Hintenlang et al. 1994a, p.124]. Figures 3.16 and 3.17 illustrate the differential pressure data across the slab for houses at Summit Oaks and Robin Lane. Pressure differentials would be expected to be the major driving forces for the convective entry of soil radon gas, but no correlation is observed. Therefore, we may infer that the presence of the radon-resistant barriers implemented in these houses does greatly reduce the pressure-driven flow of radon.

#### Summary of Radon Transport in Superstructures

Radon Transport by concrete diffusion is not significant compared to pressure-driven flow. Most house water, building materials have minor effect to the elevation of indoor radon level.

HOUSE #6 (LOT 13 - SUMMIT OAKS)  
DIFFERENTIAL PRESSURE DATA

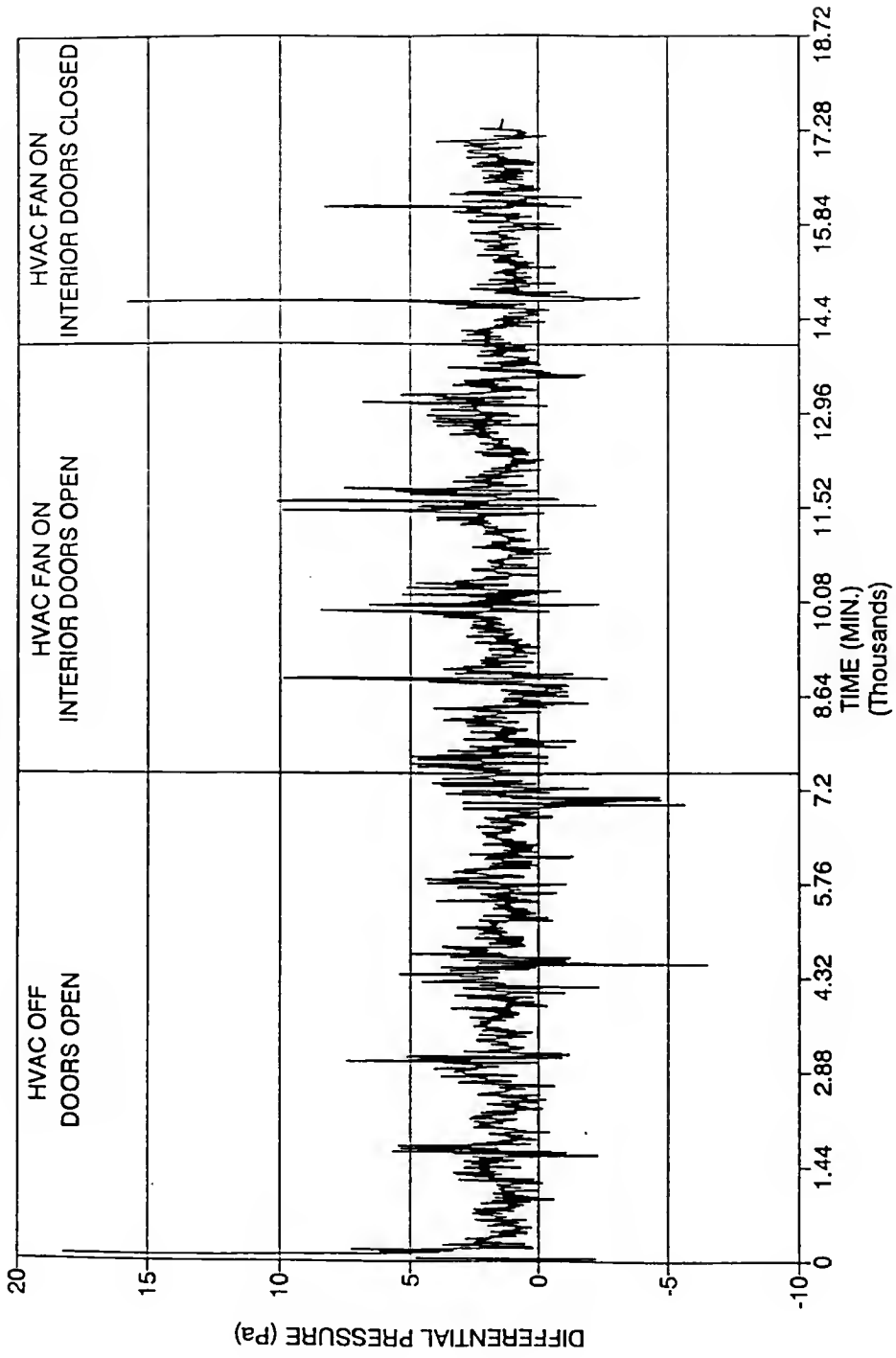

Figure 3.16 Across Slab Differential Pressure for House "Summit Oaks" [Hintenlang et al. 1994a]

HOUSE #8 (LOT 4 - ROBIN LANE)  
DIFFERENTIAL PRESSURE DATA

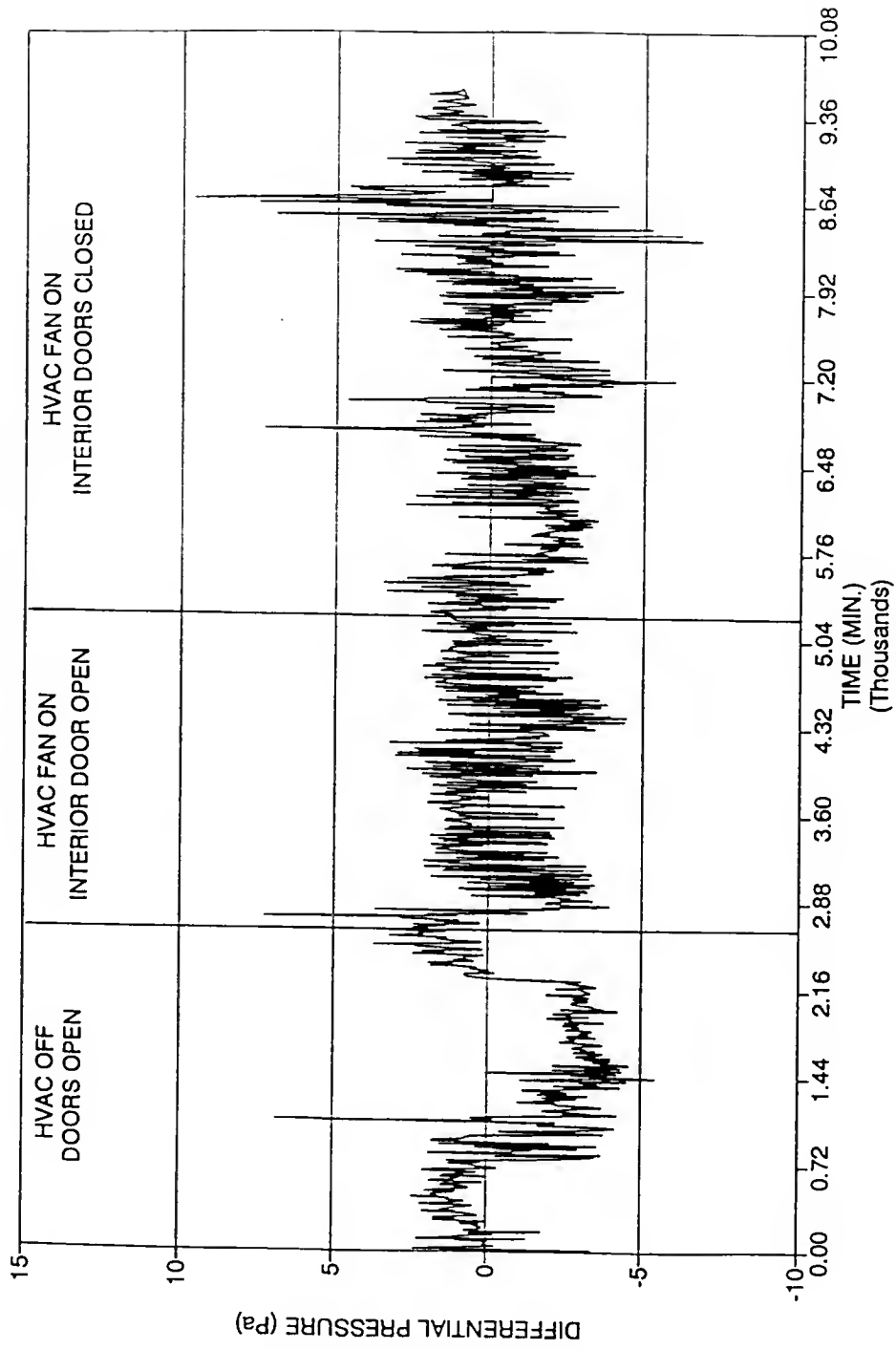

Figure 3.17 Across Slab Differential Pressure for House "Robin Lane"  
[Hintenlang et al. 1994a]

CHAPTER 4  
ANALYSIS OF HOUSE RADON AND CRACK STUDY

Introduction

This chapter analyzes the correlation between various factors that might have an effect on the entry of radon. The data are mostly extracted from reports and laboratory experiments of the research projects in the New House Evaluation Program of 1992-1993. The effectiveness of the mitigation methods employed in UF projects is discussed.

House Characteristics and Soil Radon

House physical characteristics which include foundation type, total crack length, and soil permeability (project 1992) are presented in Table 4.1. The grab counts<sup>1</sup> of the soil radon readings for each house are also listed in Table 4.2 [Najafi et al. 1993]. Soil radon grab counts were taken four hours after a site screening. The soil permeabilities are mostly in the range of  $1.0 \times 10^{-11}$  to  $1.0 \times 10^{-12}$  ( $m^2$ ) which is at the low permeability range (Refer to Chapter 2, this permeability is in the range of clay soil). Data for the project of 1993 are illustrated in Tables 4.3 and 4.4.

---

<sup>1</sup> "Grab count" means soil radon taken four hours after sampling.

Table 4.1 House Characteristics (Project of 1992)

Hous #	Foundation type	Total crack length (ft)	Soil permeability (m <sup>2</sup> )	Soil radon (Grab) pCi/L
1	Monolithic	13.5	3.92E-12~1.69E-10	690
2	Stemwall	1	1.47E-11~1.13E-11	5300
3	Stemwall	0	8.18E-13~3.45E-11	32000
4	Stemwall	15	4.03E-13~1.93E-13	2700
5	Monolithic	4	2.79E-11~1.18E-11	10000
6	Monolithic	0	6.78E-12~1.46E-11	2100
7	Monolithic	2	9.18E-12~1.10E-11	11000
8	Step slabs	12	8.95E-12~1.51E-11	2700
9	Stemwall	0	4.0E-13~2.17E-11	1900
10	Stemwall	0	5.43E-10~1.13E-09	5000
11	Monolithic	0	9.63E-10~2.24E-10	1900
12	Stemwall	19	2.83E-10~1.25E-10	2800
13	Monolithic	19	3.12E-12~1.79E-11	1400
14	Stemwall	40	2.01E-13~2.58E-12	2800

Table 4.2 Radon Test Results (Project of 1992)

House #	Subslab radon (pCi/L)	Crack radon (pCi/L)	Indoor radon (pCi/L)
1	820	4	1.2
2	7800	N/A	11.58
3	1000	N/A	2.06
4	400	1	1.92
5	3700	N/A	3.51
6	860	N/A	0.56
7	3700	N/A	0.97
8	1600	7	1.71
9	1900	N/A	2.13
10	2200	N/A	2.52
11	760	N/A	1.61
12	2700	47	1.47
13	510	9	0.93
14	2100	5	2.66
Average	2146	12	2.49

N/A: not available



Table 4.3 House Characteristics (Project of 1993)

House #	Degree of cracking	Foundation type	Total crack length (ft)
1	None	Monolithic	0
2	Moderate	Monolithic	2
3	Extensive	Monolithic	42
4	None	Monolithic	0
5	None	Monolithic	0
6	Small	Stemwall	9
7	Extensive	Monolithic	182
8	Small	Stemwall	26
9	Small	Monolithic	10
10	None	Monolithic	0
11	None	Monolithic	0
12	None	Monolithic	0

Table 4.4 Radon Test Results (Project of 1993)

House #	Soil radon (pCi/L)	Crack radon (Cch) (pCi/L)	Subslab radon (Cs) (pCi/L)	Indoor radon (pCi/L)
1	1683	N/A	N/A	2.07
2	2935	180	639	2.99
3	1189	257	431	2.24
4	911	N/A	N/A	2.7
5	2896	N/A	N/A	2.52
6	1112	48	2934	4.16
7	921	23	931	N/A
8	6607	7	306	2.72
9	1298	12	1727	N/A
10	1055	N/A	N/A	2.86
11	10661	N/A	N/A	2.6
12	6982	N/A	N/A	N/A
Average	3188	40	2233	2.07

N/A: not available

#### Soil Data Analysis

Soil radon gas is the main source of indoor radon elevation. However, indoor radon levels are affected by a complex of soil radon concentrations, soil permeability, structural type, and construction quality. Regardless of the combined effects of these parameters, indoor radon

levels are compared to soil gas radon and subslab radon levels (combined data from 1992 and 1993 projects). A simple linear regression analysis was performed using the following model [Ott 1988, p.301-311]:

$$Y = \beta_0 + \beta_1 \log(x) + \varepsilon$$

where  $Y$  = indoor radon

$x$  = soil Radon or Subslab radon

$\beta_0$  = Y intercept

$\beta_1$  = slope of the regression line

$\varepsilon$  = random error.

Figure 4.1 illustrates the poor correlation between indoor radon and soil radon. Figure 4.2 shows that indoor radon and subslab radon are poorly correlated.

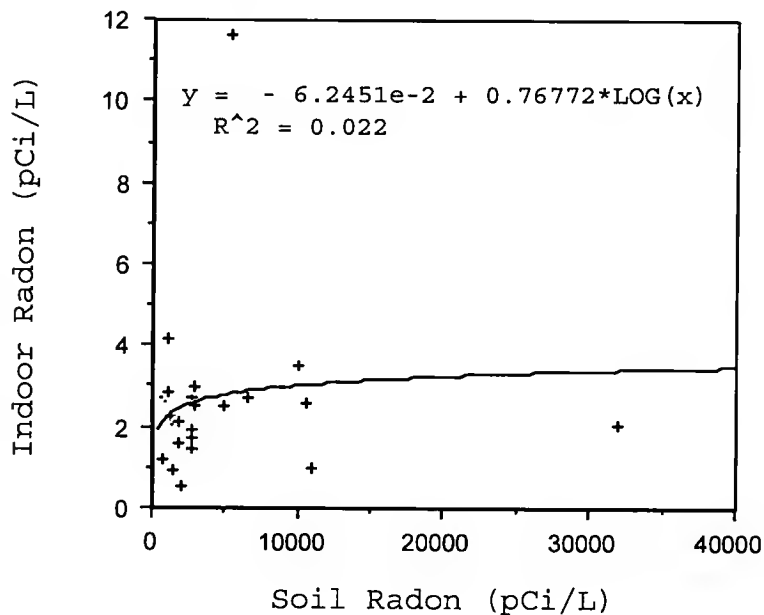

Figure 4.1 Distribution of Indoor Radon versus Subslab Radon

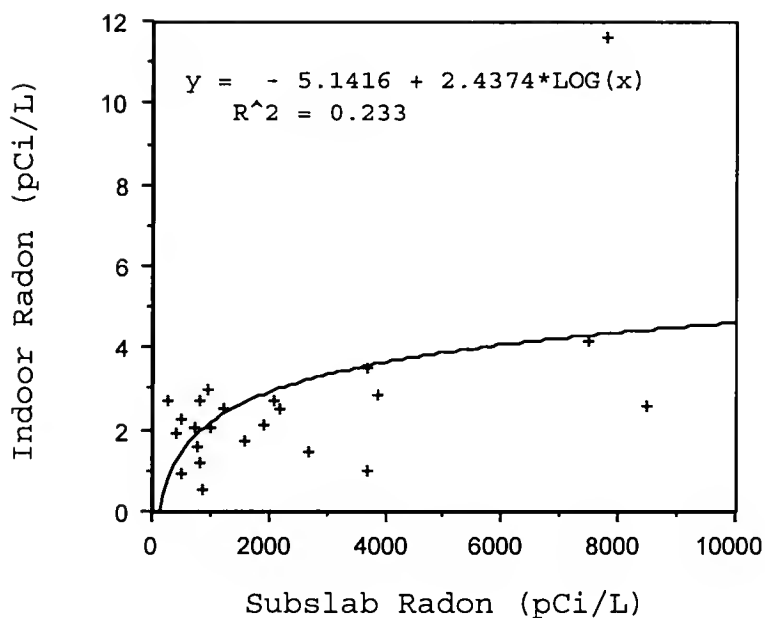

Figure 4.2 Indoor Radon versus Subslab Radon

#### Crack Study

This analysis is based on the project of the New House Evaluation Program in 1993 [Hintenlang et al. 1994a]. The crack study consisted of examining 12 new houses built in the north central Florida area which are located in Alachua and Marion counties. The purpose of the crack study is to evaluate the contribution of cracks to the entry of radon gas. Cracks are one of the most important physical characteristics to consider in a foundation slab in reducing indoor radon levels. If a large number of openings due to cracks are present in a foundation slab, the soil gas radon entering the building might elevate to an unacceptable

level. Therefore, it is necessary to identify and evaluate the potential impact of cracks on radon entry.

### Crack Research Process

The selected houses were checked for cracks one month after the concrete slab was poured. The first step of the crack study consisted of a visual inspection and crack length measurement. After using a broom to brush away dirt and construction materials, an optical comparator was used to classify cracks according to their measured width. If the crack length and width indicated more than surface cracking, crack testing was performed. Cracks were classified into four types: hairline, fine, medium, and wide. The classification is shown in Table 4.5.

Table 4.5 Crack Classification

Crack Type	Width (w) (inch)
Hairline	$w < 1/64$
Fine	$1/64 < w < 1/32$
Medium	$1/32 < w < 1/16$
Wide	$1/16 < w$

All crack types were tested except the hairline crack. The crack test consisted of two main parts: first, the pressure differentials were measured as a function of the flow rate through each crack using the permeameter; second,

radon concentration of the subslab soil gas extracted through the crack was measured using the Pylon and scintillation cells. A sniff measurement was taken on site (to serve as a reference) and a grab count was measured from this sample four hours later. The testing tube selected should be located directly underneath the crack or as close to the crack as possible. Subslab radon concentrations were similarly measured after being extracted from sampling tubes previously laid beneath the concrete slab.

The house dimensions, crack types, crack lengths, crack locations, saw cuts and construction joints were documented for each of the 12 houses. Figure 4.3 illustrates the crack map of the house located at Summit Oaks. Refer this house as Summit Oaks.

### Data Analysis

Because NHEP-1992 and NHEP-1993 have different mitigation methods and conditions, and the measurement precision is different, only NHEP-1993 data were used in the following analysis. The house data are shown in Table 4.6 and were analyzed statistically. The analyzed results are listed in Table 4.7. Statistical analysis was performed using SAS software. The first step consisted of testing the normality of the data sets. The statistical analysis indicated that the normalities of the data sets are high (Refer to Appendix A). It is consequently assumed the data sets are normal. The second step consisted of testing the

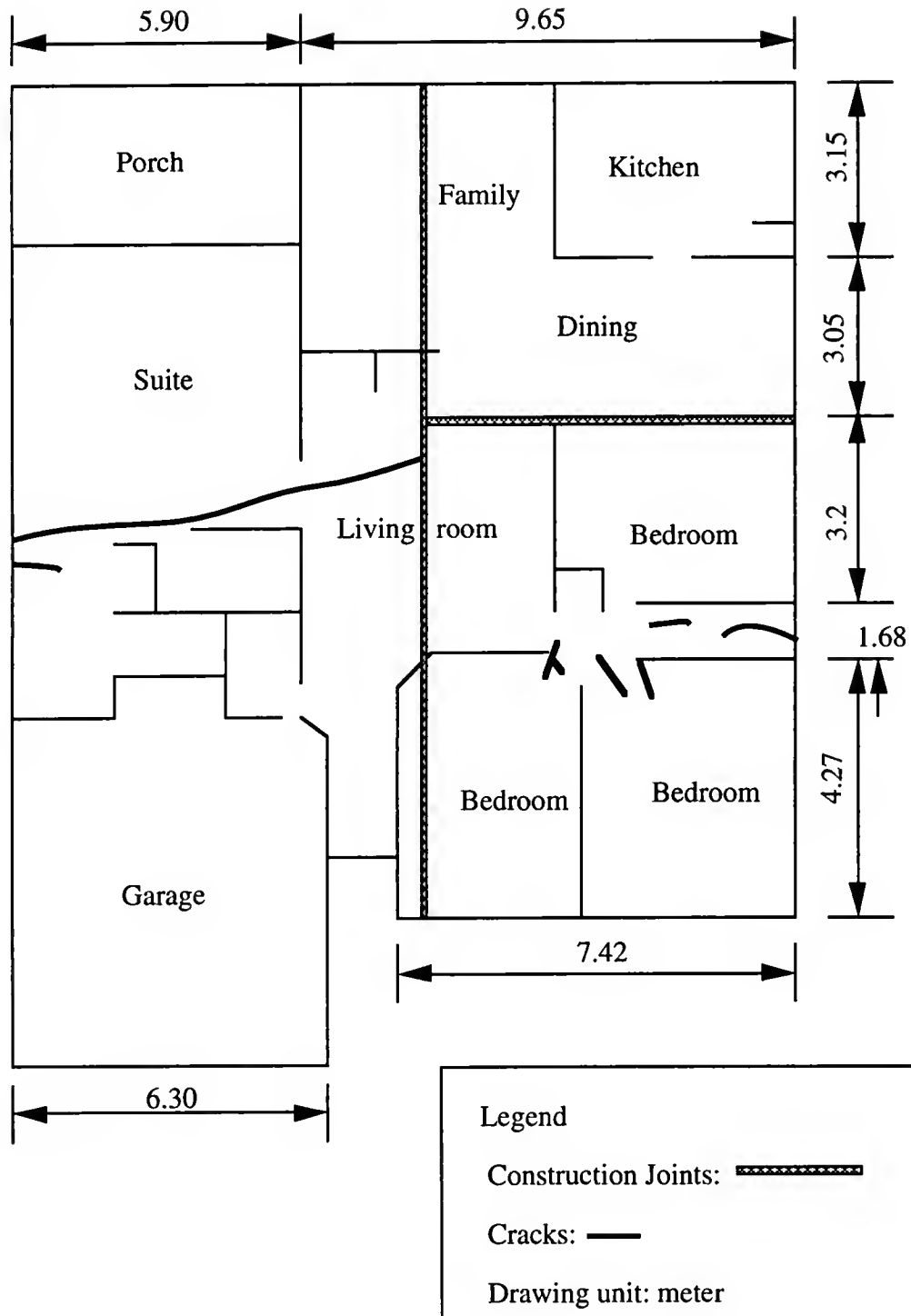

Figure 4.3 Crack Map of House Summit Oaks

correlation between factors that might affect the entry of indoor radon. The correlation model is [Ott 1988, p.319-320]:

$$Y = \beta_0 + \beta_1 x + \varepsilon$$

where

Y = dependent variable

x = independent variable

$\beta_0, \beta_1$  = regression coefficients

$\varepsilon$  = random error.

Note:

$r^2$  = coefficient of determination

r = correlation coefficient.

For this analysis, the extreme data were taken out in order to reduce variation between samples, such as the soil radon of House Number 11 and the crack length of House Number 7. The test results are shown in Table 4.8.

### Correlation Analysis

The correlation analysis, as shown in Table 4.8, indicates a low correlation between indoor radon levels and crack parameters. However, there is a strong correlation ( $r^2 = 0.94$ ) between average indoor radon concentrations and subslab soil radon concentrations.

This analysis only considered the correlation between two data sets, i.e., the interrelationship with the third data set was ignored.



Table 4.6 House Characteristics

House #	Crack Length(in)	TECA	FOM	CE (%) (Cch/Cs)
1	N/A	N/A	N/A	N/A
2	24	5.4E-5	9.27E-3	28.17
3	132	1.68E-5	3.81E-3	60
4	N/A	N/A	N/A	N/A
5	N/A	N/A	N/A	N/A
6	108	6.23E-5	3.64E-6	1.64
7	1668	9.44E-6	2.83E-5	2.4
8	312	2.99E-4	2.03E-3	2.22
9	120	1.84E-5	2.21E-4	0.69
10	N/A	N/A	N/A	N/A
11	N/A	N/A	N/A	N/A
12	N/A	N/A	N/A	N/A

Note: TECA: Total Equivalent Crack Area (in<sup>2</sup>)

FOG: Figure of Merit (pCi/L·in<sup>2</sup> )

CE: Crack Efficiency (%)

Table 4.7 House Basic Statistics in the Crack Study

Variable	Observations	Minimum	Maximum	Mean	Standard deviation
Crack length (inch)	11	0	312	63	99
Soil radon (pCi/L)	11	911	6607	2454	1470
Crack radon (pCi/L)	12	0	227	40	78
Subslab radon (pCi/L)	6	306	2394	1237	1185

Table 4.8 Correlations between Factors

Correlation	Indoor radon	Soil radon	Subslab radon	Crack radon	Crack length
Indoor radon	1	-0.102	0.94	-0.02	0.14
Soil radon	-0.102	1	-0.617	-0.173	0.587
Subslab radon	0.94	-0.617	1	-0.352	-0.307
Crack radon	-0.02	-0.173	-0.352	1	0.163
Crack Length	0.14	0.587	-0.307	0.163	1

### Calculation of Crack Parameters

Crack parameters are defined as follows:

$$A = Q / (K \times \Delta p)^n$$

where  $K = 0.29$ ,  $\Delta p = 4$  pascal,  $Q =$  flow rate ( $\text{m}^3/\text{s}$ ) at 4 pascal,  $n =$  slope of log of flow rate vs. log of pressure differentials (which can be found in the plot, refer to Figure 4.4)

Total Equivalent Crack Area

$$= (A \times \text{Total Crack Length}) / 18.5 \text{ inch}$$

Figure of Merit = Crack Radon x Total Equivalent Area

Crack Efficiency = Crack Radon / Subslab Radon x 100%

### Comparison of Crack Characteristics with Indoor Radon

By comparing the average indoor radon and subslab radon concentrations it was determined, as expected, that when subslab radon increases, indoor radon increases as well. The  $R^2$  was 0.88 as shown in Figure 4.5. It should be noted that only four data sets were available for this analysis. In Figure 4.6, the ratio of indoor radon and subslab radon is compared to the total equivalent crack area (T.E.C.A). The increase of T.E.C.A corresponds to an increase in the ratio of indoor radon/subslab radon concentrations, which indicates that crack openings do affect radon entry.

### Potential Crack Radon Entry Analysis

By calculating the flow of soil gas entering the test

SUMMIT OAKS  
LOT #13

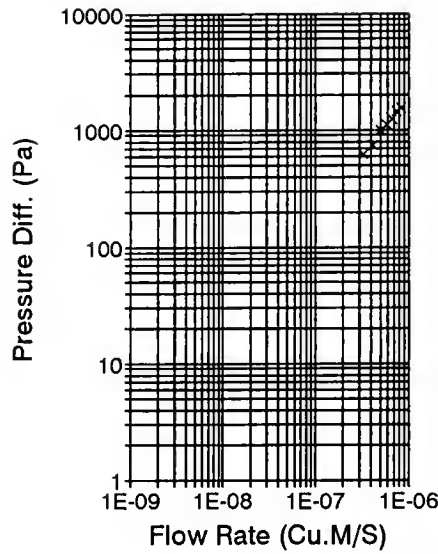

Type of Crack: Fine  
 Total Crack Length: 108 in  
 Radon Conc. (crack): 48.2 (pCi/L)  
 Radon Conc. (sub-slab): 2934 (pCi/L)

$Q = 2.1E-09$  (Cu.M/S)  
 $n = 1.009$

$A = Q / (Kx(\Delta p)^n)$   
 $= 4.02E-10$  Sq.M / L  
 $= 6.23E-07$  Sq. in / L

FLOW RATE (Cu.M/S)	PRESS. DIFF. (Pa)
1.67E-07	548
3.33E-07	623
4.17E-07	747
5E-07	996
5.83E-07	1096
6.67E-07	1245
7.5E-07	1444
8.3E-07	1544

Total Equivalent Crack Area  
 $= (A \times \text{Total Crack Length}) / 18.5 \text{ in}$   
 $= 3.64E-06$  Sq. in.

Figure of Merit  
 $= Rn(\text{crack}) \times \text{Total Eq. Area}$   
 $= 1.75E-04$  (pCi/L)(Sq.in)

Crack Efficiency  
 $= Rn(\text{crack}) / Rn(\text{sub-slab})$   
 $= 1.64\%$

Figure 4.4 Calculation of Total Crack Equivalent Area

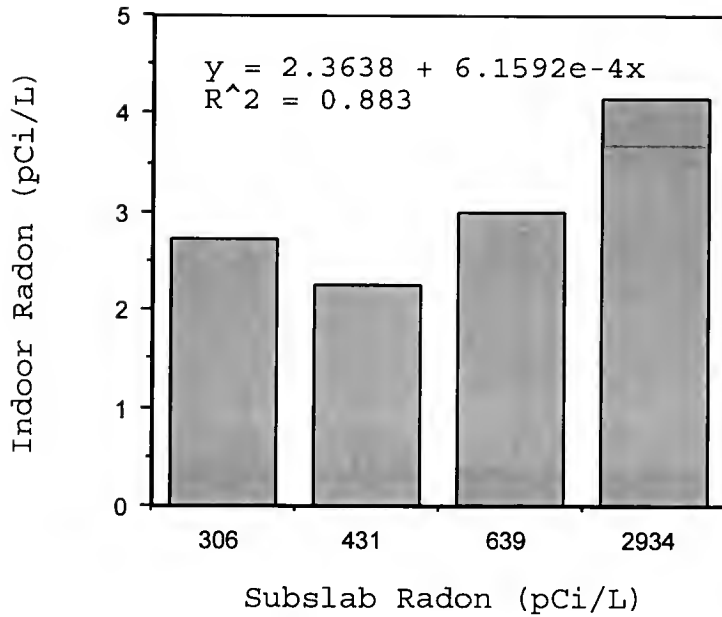

Figure 4.5 Average Subslab Radon versus Indoor Radon Concentration

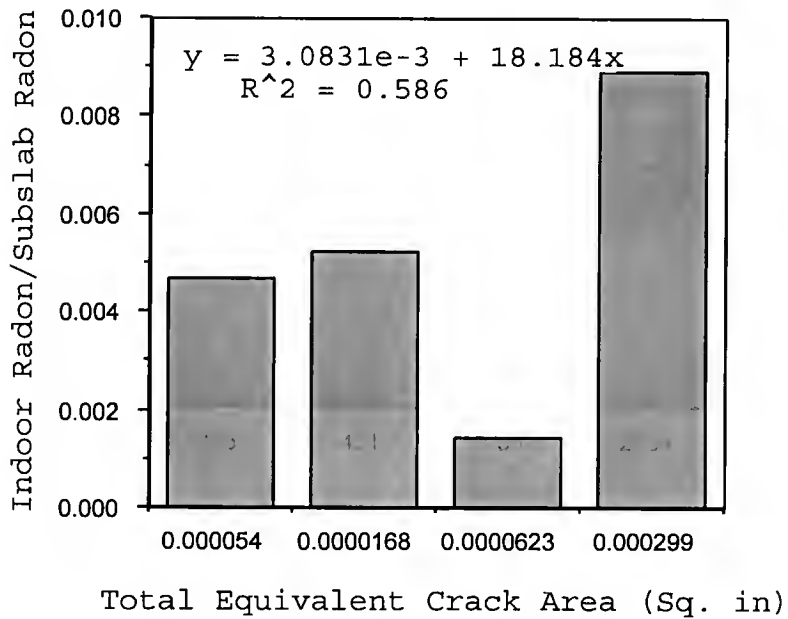

Figure 4.6 Indoor Radon/Subslab Radon versus Total Equivalent Crack Area

chamber, the radon entry potential for normalized values of soil gas radon concentrations can be evaluated. The soil radon concentrations and chamber radon concentrations can be related to the other parameters by the following equation:

$$\begin{aligned} & \text{flow from sub slab/total flow into chamber} \\ & = Q_S/Q_{Ch} \\ & = C_S/C_{Ch} \end{aligned}$$

where  $Q_S$  is the flow from the subslab through the crack,  $Q_{Ch}$  is the total flow into the chamber,  $C_S$  is the measured subslab radon concentration, and  $C_{Ch}$  is the measured radon concentration in the test chamber. Since  $Q_{Ch}$ ,  $C_S$  and  $C_{Ch}$  are independently measured, the volumetric flow rate of soil gas into the structure can be calculated by:

$$Q_S = Q_{Ch}(C_S/C_{Ch})$$

A fundamental quantity in this analysis is therefore the ratio  $C_{Ch}/C_S$ , which provides a direct measure of the fraction of soil gas entering the chamber through the crack. The values of  $C_{Ch}/C_S$  are less than 5% in four of the six houses (Refer to Table 4.6). However, two houses exhibited  $C_{Ch}/C_S$  in the range of 25% to 60%, indicating that significant fractions of soil gas were entering the test chamber through the crack being examined. Most houses have low  $C_{Ch}/C_S$  values, indicating that the vapor barriers are intact underneath the crack location tested. For the houses which have large values of  $C_{Ch}/C_S$ , the vapor barriers were most likely penetrated during the construction process.

### Crack Resistance Analysis

The soil gas entry rate for each house under an applied depressurization of 4 Pascal (Pa) is calculated. The average soil gas entry is  $8.89 \times 10^{-8} \text{ m}^3 \text{ s}^{-1}$  for these six houses exhibiting slab cracking. The total resistance of the crack opening is calculated using the technique described in the Florida A&M University (FAMU) crack study report as follows:

$$I_{\text{system}} = P^n / Q_s$$

where  $I_{\text{system}}$  is the total resistance of the crack system,  $P$  is the differential pressure (Pa) across the crack and fill combination. As in the FAMU crack study report, it is assumed that the flows are small enough so that the exponent,  $n \cong 1$ , is utilized.

The measured crack resistances observed in this study are illustrated in Figure 4.7. Most of these houses exhibit crack resistances between  $10^{+7}$  to  $10^{+9} \text{ Pa s m}^{-3}$ . The average value is  $6.0 \times 10^{+8} \text{ Pa s m}^{-3}$ , which is higher than the values found in the 1993 crack study project that evaluated existing structures in Alachua, Marion and Polk counties [Hintenlang et al. 1994b].

Crack resistances of the three projects are listed in Table 4.9. This suggests that the newly constructed slabs in these projects have higher crack resistance than those observed from existing houses with ages greater than two years.

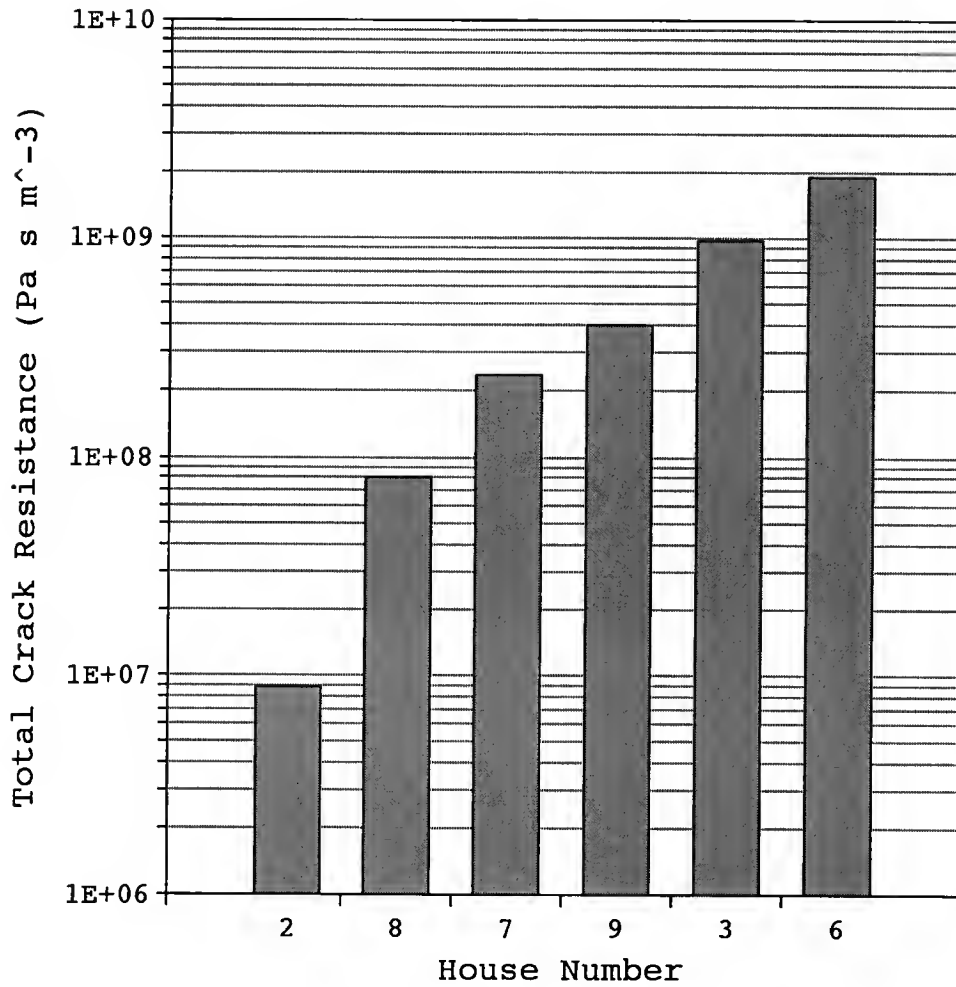

Figure 4.7 Crack Resistances of the Houses Tested



Table 4.9 Crack Resistance in Three Projects

Research project	year	Average crack resistance (Pa s m <sup>-3</sup> )
Existing Building	1993	4.8 x 10 <sup>+6</sup>
New House Evaluation	1993	6.0 x 10 <sup>+8</sup>
Large Building	1994	3.6 x 10 <sup>+8</sup>

#### Crack Study Summary

Twelve houses were studied in the project of 1993. Six houses had either no cracks or insignificant hairline cracks. Crack studies were performed on the other six houses. Throughout the crack study, it was found that construction joints stopped crack extension effectively. The location and installation of construction joints is a major factor in minimizing crack development. In most houses properly installed construction joints prevented cracks from occurring. Only a few houses experienced cracks with the existence of properly installed construction joints. A house located in Hayes Glen subdivision, which did not install construction joints, had many more cracks than usual. Apparently, the post-tension design may have contributed to crack development. An enormous number of cracks developed in areas where grade beams intersected. Several different builders had worked in the project. Some builders had very few cracks in the houses they built and were observed to perform high standard construction practices.

Other builders had more cracks in their houses and did not demonstrate the same quality of construction. It is reasonable to assume that the quality of construction directly affects the number of cracks that develop in a slab. Other factors that could affect crack development include: temperature, curing method used, and the sediment of the foundation. The research teams observed several key factors that reduce crack development:

- 1) construction joints (properly designed and placed)
- 2) proper curing methods
- 3) sufficient curing time
- 4) a positive quality control from the builder.

The construction quality can be improved by considering these major issues. A quality built house usually is built by a builder who performs and considers these issues.

The  $C_{ch}/C_s$  values for most of the houses are less than 5% which indicates that the newly constructed houses have vapor barriers which effectively prevent radon entry (refer to Table 4.6). The average crack resistance exhibited was higher than those previously found in the existing houses with ages greater than two years old (Refer to Table 4.9). Therefore, the vapor barrier systems are successful in reducing radon entry into houses.

#### Infiltration and Indoor Radon Test Results

Radon enters houses mainly by diffusion and pressure-driven flow. Diffusion has been proven not to be a major

radon entry mechanism. Pressure differentials of indoor and subslab are the prime factors of radon entry. Pressure differentials are related to the house ventilation rate. Four experiments were performed for house ventilation analysis.

These four tests were performed by using different conditions: 1) natural ventilation with all mechanical systems off and interior doors open; 2) air handler on with doors open; 3) air handler on with doors closed; and 4) exhaust fan on with doors closed. The first three tests are referred to as the passive ventilation, while the last test is considered the active ventilation. The test data of project in 1992 is illustrated in Table 4.10.

A statistical analysis was applied for comparing the mean values of the four tests. The data were analyzed using the SAS statistical software package [Littell et al. 1993]. The hypothesis of the test statistics is as follows:

$H_0: \mu_1 = \mu_2 = \mu_3 = \mu_4$ ;  $H_a$ : one of them not equal

$\mu_i$  = Infiltration rate (air change per house) of test  $i$

By referring to the program output in Table 4.11, the  $F$  (test statistics) and  $p$  (Probability  $> F_{3,51}, \alpha=0.05$ ) values are 35.07 and 0.0001, respectively. Because the  $F$  value

Table 4.10 Infiltration Rate and Indoor Radon Concentration

House	Test 1		Test 2		Test 3		Test 4	
#	ACH	In- door Radon	ACH	In- door Radon	ACH	In- door Radon	ACH	In- door Radon
1	0.144	2.3	0.327	1.2	0.626	1.6	0.169	0.8
2	0.495	5.3	0.424	6.8	0.557	5.4	0.159	N/A
3	0.215	1.5	0.317	1.2	0.631	1.0	0.188	N/A
4	0.278	1.0	0.352	0.6	0.743	0.7	0.111	0.6
5	0.190	1.7	0.419	1.4	0.687	1.0	0.372	1.5
6	0.203	0.9	0.412	0.6	0.437	0.5	0.174	0.7
7	0.121	1.2	0.518	0.9	0.786	0.5	0.247	0.4
8	0.331	1.0	0.553	0.8	0.735	0.6	0.223	1.0
9	0.208	0.7	0.3	0.8	0.764	0.7	0.145	1.0
10	0.316	0.7	0.928	0.6	0.916	0.1	0.294	0.6
11	0.179	0.6	0.407	1.0	0.763	0.8	0.141	0.6
12	0.545	0.9	0.553	1.2	N/A	N/A	0.465	1.0
13	0.2	0.6	0.404	0.7	0.811	0.3	0.213	0.3
14	0.192	0.5	0.335	1.0	0.493	0.7	0.23	0.5
Avg.	0.258	1.35	0.446	1.342	0.688	1.069	0.223	0.75

Table 4.11 Multiple Comparison of Means

General Linear Models Procedure					
Dependent Variable: ACH					
Source	DF	Sum of Squares	Mean Square	F Value	Pr > F
Model	3	1.8274903	0.6091634	35.07	0.0001
Error	51	0.8858327	0.0173693		
Corrected Total					
	54	2.7133230			
R-Square		C.V.	Root MSE	ACH Mean	
0.673525		33.02920	0.1318	.3990182	
Source	DF	Type I SS	Mean Square	F Value	Pr > F
TEST	3	1.8274903	0.6091634	35.07	0.0001
Source	DF	Type III SS	Mean Square	F Value	Pr > F
TEST	3	1.8274903	0.6091634	35.07	0.0001

Tukey's comparison of means

## General Linear Models Procedure

Tukey's Studentized Range (HSD) Test for variable:  
 ACH NOTE: This test controls the type I experimentwise error  
 rate. Alpha= 0.05 Confidence= 0.95 df= 51 MSE= 0.017369

Critical Value of Studentized Range= 3.756

Comparisons significant at the 0.05 level are indicated by

'\*\*\*'.

TEST Comparison	Simultaneous		Simultaneous Upper Confidence Limit	
	Lower Confidence Limit	Difference Between Means		
3 - 2	0.1072	0.2420	0.3768	***
3 - 1	0.2952	0.4300	0.5648	***
3 - 4	0.3299	0.4647	0.5996	***
2 - 3	-0.3768	-0.2420	-0.1072	***
2 - 1	0.0557	0.1880	0.3203	***
2 - 4	0.0904	0.2227	0.3550	***
1 - 3	-0.5648	-0.4300	-0.2952	***
1 - 2	-0.3203	-0.1880	-0.0557	***
1 - 4	-0.0976	0.0347	0.1670	
4 - 3	-0.5996	-0.4647	-0.3299	***
4 - 2	-0.3550	-0.2227	-0.0904	***
4 - 1	-0.1670	-0.0347	0.0976	

is larger than the critical value,  $F_{3,51}(\alpha=0.05) = 2.80$ ,  $H_0$  at  $\alpha = 0.05$  level is rejected; therefore, the means are not all equal.

Furthermore, from Tukey's comparisons [Ott 1988], the results can be interpreted as  $\mu_3 > \mu_2 > \mu_1 = \mu_4$ . This result is as expected, that is, the ACH is largest at air handler on with all doors closed, and the ACH is smallest when all mechanical systems are off with doors open. The average indoor radon levels and infiltration rates are shown in Figure 4.8. The first three tests which all have exhaust fans turned off is plotted in Figure 4.9.

In comparing the average infiltration rates with average indoor radon levels, we verify that an increasing infiltration rate results in a decreasing indoor radon level. However, this is based on the average values of the three tests. Note that indoor radon levels and ACH vary over time.

#### Two Radon Research Experiments

Two experiments were conducted to verify the research assumptions and precision. First, tubes previously laid in the large building project were used for testing the effect of tube length on the radon readings. Second, a pressure

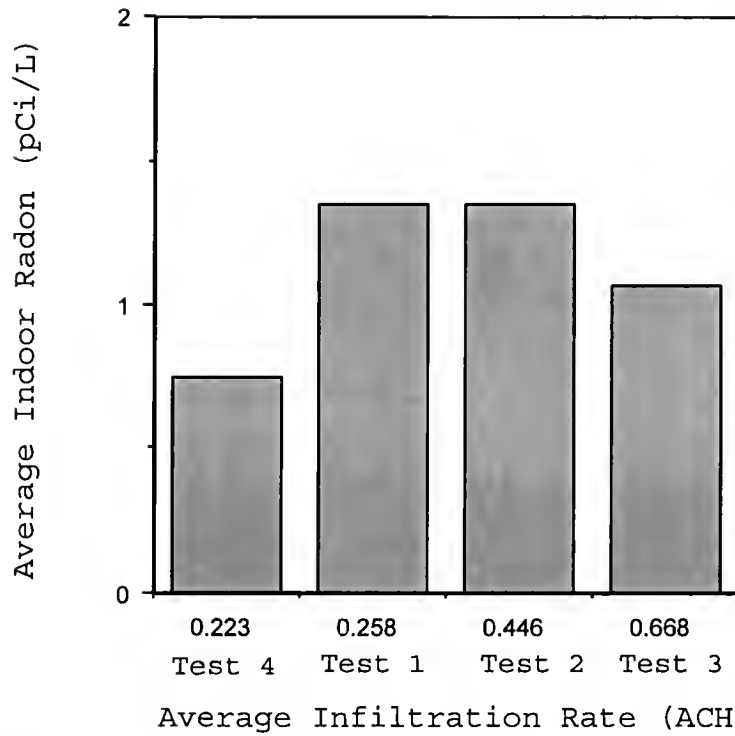

Figure 4.8 Indoor Radon Levels vs. Infiltration Rates

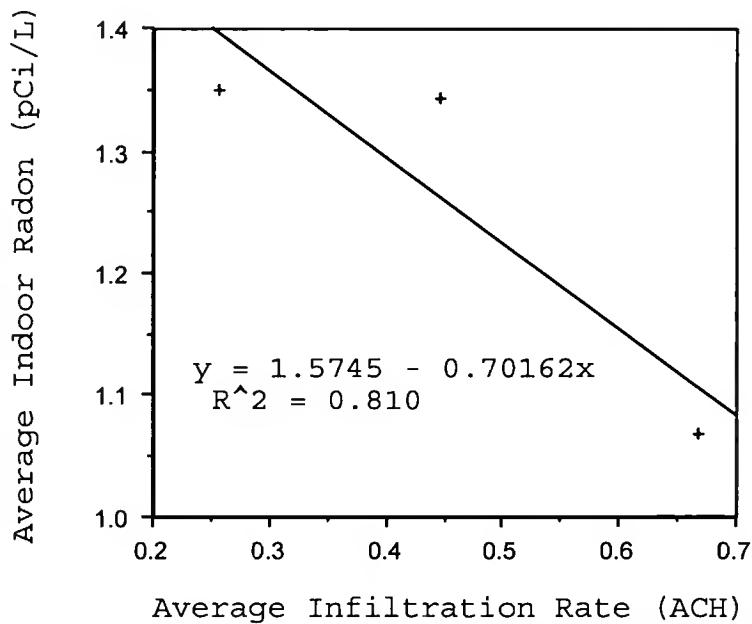

Figure 4.9 Correlation Between Indoor Radon and Infiltration Rates

differentials test was conducted at the research house.

### Effectiveness of Tube Length on the Measurement of Radon Concentration

Radon measurements have been performed under all kinds of conditions due to geological accessibility, house structure, and other limitations. Radon measurements are performed for differing tube lengths. The effect of tube length on radon measurements is usually ignored. One example could be the subslab radon measurement. Subslab radon concentrations are usually taken after the concrete floor slab is poured. The testing points underneath the concrete slab are connected by plastic tubes. The tubes are collected into a two-inch pipe for future radon measurements. The tubes to the collector is in a radioactive type. Therefore, each testing point to the collector has a different length.

### Equipment Used

Radon measurements were taken using a pylon AB-5 radon monitor and model 300 Lucas scintillation cells. Radon flux readings were obtained from plastic tubes with 0.4-cm inner diameter and 0.5-cm outside diameter. The tubes were pre-cut in 5-ft lengths each. The connections of the tubes were taped.

### Testing Procedures

Prior to the test, prepare tubes in 5-ft lengths each and have a total length of 50 feet. When measuring radon



concentrations, measure the initial readings of the tube and add a 5-ft length for the following tests. For the initial tube, let the pump run for 5 minutes or more to ensure enough time for radon flux to come into the cell. Check the exhaust valve to make sure the flow is abundant. If the flow is small, check the connection between the pylon, the tube and the open/close control valve. Each time take a 5-minute grab sample and then take a 30-minute grab count after 4 hours. Record each initial testing time and grab time.

#### Site Selection and Testing

The Large/Commercial Building project's Wade Raulerson Honda building was selected for testing since it has the tubes previous laid underneath the slab. The testing point had an average of 245 pCi/L radon level. The test was performed at an initial length of 12 feet. The testing point is about two feet from the collector.

#### Test Results

The test was conducted over two days but had similar weather conditions. Both days were sunny and had a temperature of about 80<sup>0</sup> F. Test results are shown in Tables 4.12 and 4.13. Figure 4.10 illustrates the tube lengths that affect radon readings. It suggests that radon readings are affected by the changes of tube length. The R<sup>2</sup> value of tube lengths and radon readings is 0.97, which means that they are highly correlated.

Table 4.12 Tube Lengths and Their Calculated Radon Readings (0-25 ft)

Effectiveness of tubing length for radon concentration measurements																		
Sample Site: Wade Raulerson Honda Building																		
Initial length: 12 ft																		
Sample Date: 11/22/94																		
Weather: Sunny 80 F																		
Length(ft)	5		10		15		20		25		30		35					
	Initial	203	761	564	596	720	844	968	1092	1216	1340	1464	1588	1712				
Cell#	763																	
Sample time	8:36 Am	8:44 Am	9:53 Am	9:01 Am	9:09 Am	9:19 Am	9:27 Am	9:35 Am	9:43 Am	9:51 Am	9:59 Am	10:07 Am	10:15 Am	10:23 Am				
Grab Time	12:38 Pm	1:15 Pm	1:49 Pm	3:49 Pm	4:23 Pm	4:57 Pm	5:31 Pm	6:05 Pm	6:39 Pm	7:13 Pm	7:47 Pm	8:21 Pm	8:55 Pm	9:29 Pm				
Readings after min. of filling																		
Count	242	271	288	408	434	308	408	434	308	408	434	308	408	434				
	CPM	PC/I	CPM	PC/I	CPM	PC/I	CPM	PC/I	CPM	PC/I	CPM	PC/I	CPM	PC/I				
1	243	445	321.17	272	262	189.78	297	251	182.39	408	244	178.82	435	143	105.73	309	87	70.59
2	244	432	284.68	273	250	158.28	288	243	171.55	410	233	147.20	436	170	107.75	310	80	49.91
3	245	446	283.92	274	284	177.55	289	237	187.34	411	234	147.85	437	173	108.87	311	101	83.02
4	246	431	284.07	275	275	171.95	300	251	177.25	412	227	143.45	438	153	87.00	312	85	59.28
5	247	468	282.13	276	251	154.96	301	258	182.18	413	228	143.73	439	150	85.11	313	119	74.27
6	248	425	280.18	277	287	179.50	302	285	201.31	414	214	135.27	440	140	88.78	314	92	57.42
7	249	388	255.82	278	258	162.01	303	231	163.19	415	189	119.46	441	160	101.46	315	89	55.56
8	250	397	261.79	279	269	168.28	304	258	180.87	416	230	145.42	442	159	100.88	316	108	87.43
8	251	473	311.95	280	285	185.90	305	238	168.78	417	215	135.95	443	141	89.45	317	105	85.56
10	252	448	294.13	281	305	190.85	306	244	172.43	418	205	123.94	444	134	87.71	318	84	58.70
11	253	458	302.13	282	308	182.75	307	252	178.11	419	205	129.88	445	163	103.43	318	81	50.59
12	254	437	286.31	283	297	185.89	308	242	171.08	420	181	114.46	446	148	93.93	320	110	88.71
13	255	375	247.44	284	298	188.54	308	236	168.28	421	222	140.45	447	158	100.82	321	91	56.85
14	256	418	274.53	285	254	159.02	310	282	208.46	422	208	130.34	448	159	100.83	322	95	56.36
15	257	387	252.02	286	245	155.81	311	272	180.52	423	208	145.81	449	145	87.61	323	102	83.74
18	258	440	280.44	287	279	174.71	312	289	190.24	424	195	123.41	450	151	95.88	324	109	88.12
17	259	405	287.37	288	268	187.85	313	231	163.39	425	221	139.88	451	145	92.08	325	108	88.28
18	260	387	282.12	289	257	180.98	314	254	178.88	428	218	136.74	452	141	89.55	326	84	52.51
18	261	388	254.86	290	273	171.02	315	265	187.48	427	218	138.65	453	181	102.27	327	102	83.77
21	262	483	284.85	291	288	177.89	316	286	188.22	428	182	121.57	454	159	101.01	328	84	55.05
21	263	411	271.47	292	277	173.57	317	255	180.46	428	240	151.88	455	185	104.83	329	102	83.79
22	264	420	277.45	293	287	187.33	318	257	181.90	430	211	133.64	456	131	83.24	330	102	83.79
23	265	481	304.57	294	278	174.24	319	242	171.30	431	217	137.46	457	152	96.80	331	98	81.30
24	266	409	270.25	295	311	194.95	320	282	189.64	432	238	150.78	458	177	112.50	332	87	80.68
25	267	432	272.58	296	275	171.85	321	248	173.38	433	212	134.32	459	152	95.82	333	80	66.05
26	268	412	272.30	297	288	179.32	322	222	157.20	434	215	136.24	460	148	94.09	334	88	55.07
27	269	438	288.20	298	280	183.04	323	257	182.01	435	230	145.76	461	162	103.01	335	84	52.57
28	270	425	280.96	299	290	181.88	324	278	198.81	436	218	136.81	462	149	84.75	336	67	41.94
29	271	433	286.26	300	278	175.00	325	249	178.39	437	223	141.38	463	149	84.78	337	92	57.59
30	272	387	255.90	301	287	180.04	326	252	185.82	438	214	135.88	464	158	94.23	338	112	70.12
Average		278.78			173.72				179.02			118.84			88.03			60.45
Std. Dev.		17.35			10.99				12.09			6.86			7.23			7.23

Table 4.13 Tube Lengths and Their Calculated Radon Readings (25-50 ft)

Sample Site: Wade Raulerson Honda Building		Sample Date: 11/23/94		Weather: Sunny 80 F														
Length (ft)	Cell#	30	35	40	45	50												
Sample time	Grab Time	10:52 Am	11:01 Am	11:10 Am	11:20 Am	11:29 Am												
Readings after min. of filling		3:28 Pm	4:14 Pm	5:45 Pm	6:31 Pm	7:06 Pm												
Count	248	278	313	395	431	457												
	CPM	PC/I	CPM	PC/I	CPM	PC/I												
1	249	86	82.12	277	116	84.08	314	55	40.05	398	48	35.32	432	54	39.91	458	44	32.83
2	250	93	81.33	278	93	58.17	315	52	38.79	397	87	42.28	433	45	28.51	459	31	19.71
3	251	77	50.78	278	95	59.43	318	64	45.29	398	58	38.59	434	51	32.32	480	48	30.52
4	252	90	59.36	280	104	65.07	317	54	38.21	399	64	40.38	435	52	32.96	461	31	19.71
5	253	85	58.77	281	114	71.33	318	71	53.95	400	53	38.93	436	53	38.79	462	34	22.88
6	254	87	57.40	282	108	67.59	319	69	48.94	401	61	38.49	437	52	32.98	463	38	24.17
7	255	90	52.78	283	85	53.20	320	45	31.88	402	53	33.45	438	42	28.63	464	35	22.26
8	256	83	61.37	284	94	58.84	321	43	30.45	403	67	42.29	439	53	33.61	465	45	28.63
9	257	85	58.10	285	78	48.83	322	55	38.95	404	72	45.45	440	34	21.56	466	37	23.54
10	258	82	54.33	286	96	54.33	323	43	30.85	405	58	43.58	441	37	29.87	467	48	31.18
11	259	66	43.57	287	105	65.75	324	52	36.83	406	77	48.62	442	55	34.89	468	33	21.00
12	260	78	52.16	288	81	50.73	325	57	40.38	407	56	35.37	443	44	27.91	469	46	29.28
13	261	78	51.51	289	100	62.84	329	51	38.13	408	50	31.58	444	53	33.63	470	31	18.73
14	282	87	57.46	290	108	66.28	327	44	31.18	409	53	33.48	445	42	26.65	471	45	28.85
15	283	81	51.82	291	81	54.33	328	67	47.88	410	45	31.98	446	38	27.79	472	36	24.30
16	284	71	48.90	292	81	50.76	328	66	48.78	411	60	37.81	447	55	34.91	473	53	33.75
17	285	70	48.25	293	87	54.52	330	51	38.15	412	57	38.02	448	53	33.84	474	50	31.84
18	286	84	82.11	294	82	51.39	331	81	43.24	413	60	37.92	449	43	27.30	475	48	30.57
18	287	72	47.58	295	108	68.33	332	49	34.74	414	68	42.98	450	81	38.73	478	40	25.48
20	288	71	45.83	296	102	64.33	333	64	45.83	415	48	30.88	451	48	31.12	477	47	28.84
21	289	82	54.20	297	113	70.85	334	55	39.01	418	45	28.45	452	53	33.88	478	38	22.84
22	270	84	55.53	298	87	54.59	335	62	43.98	417	48	30.35	453	83	40.02	478	35	22.30
23	271	78	52.23	299	103	84.80	336	54	38.31	418	58	38.68	454	48	30.48	480	36	22.84
24	272	87	57.53	300	104	85.23	337	53	37.80	419	74	46.80	455	58	38.85	481	33	21.04
25	273	78	50.82	301	102	83.95	338	57	38.81	420	57	38.36	456	51	34.76	482	43	27.41
26	274	78	52.25	302	114	71.52	339	63	44.71	421	63	38.88	457	47	29.87	483	40	25.50
27	275	68	45.84	303	91	57.10	340	47	33.98	422	72	45.56	458	46	28.24	484	46	29.33
28	278	74	48.98	304	104	65.27	341	53	37.62	423	57	36.07	459	53	33.88	485	37	23.80
29	277	76	50.28	305	110	69.04	342	83	44.72	424	61	38.61	460	50	31.78	486	34	21.89
30	278	72	47.83	306	107	67.32	343	45	31.95	425	58	39.71	461	55	35.63	487	45	25.33
Average		5.107		62.08		7.89		39.28		36.18		32.52		25.71				
Std. Dev.		5.15		7.89		5.59		4.83		4.83		4.24		4.18				

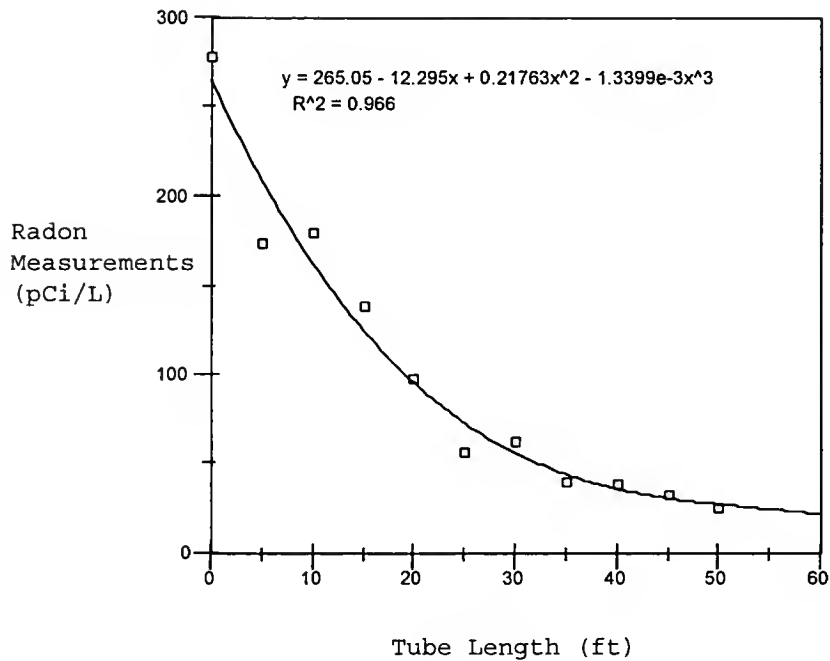

Figure 4.10 Tube Lengths and Their Radon Readings

### Discussion of the Experiment

Radon readings are affected by the length of tube which is proven by the test results. In general, the readings drop along with the increase of tube length. The reason for this drop could be that the source of radon flux is not sufficient enough to charge the tube.

Also, the connection between each 5-ft tube in each test might have a leak which cannot be seen by human eyes. However, the leakage should be a minimal and can be neglected. Besides, the leakage could be a system error for the successors.

The test result shows a strong correlation between tube length and the corresponding radon measurements. The results suggest that when measuring radon, one should consider the length of the measuring tube. Radon measurement should be standardized for all tests in order to have consistent system errors.

### Indoor Radon Concentration Variation Due to Pressurization

Indoor radon concentration varies with time due to temperature or pressure changes. Pressure differentials between indoor and subslab have proven to be the major entry mechanism of indoor radon. It is obligatory to perform pressure differential tests to assess the influence of the indoor radon concentration.

### Objective of the Experiment

Mechanically induces pressure changes to examine the effect on the indoor radon concentrations. Indoor radon concentration could be diluted by pressurizing indoor.

### Experimental Procedure

To mechanically pressurize the house, use the blower door to increase indoor pressure greater than the mean environmental pressure. Continuously measure the indoor radon concentrations in room 1 and room 4 of the research house<sup>2</sup>. After 24 to 48 hours, use the blower door to pressurize room 4 at 8 pascal for 15 minutes and then turn

---

<sup>2</sup> The research house is a part of the NHEP and is located in N.E. 20th Terrace in Gainesville, Florida.

off the blower door. It is to be noticed that the radon readings were continuous from the beginning until the end of the experiment. Radon concentrations were measured by using Pylon AB-5 with passive radon diffusion (PRD) cells. Mechanical pressurization was achieved by using a blower door.

### Experimental Results

The results of the experiment are shown in Figure 4.11. The plot suggests that room 1 had higher indoor radon concentrations than room 4 before the blower door was used. When the blower door was operated, the indoor radon concentrations of both rooms dropped drastically to below 10 pCi/L. However, when the blower door was turned off, indoor radon concentrations of both rooms started to recover. Based on the plot, indoor radon concentrations for both rooms had not recovered after about two and half hours.

### Discussion of the Experiment

Indoor radon concentrations were affected by pressurization of the blower door. Indoor radon concentrations dropped drastically when the blower door was applied. In room 4, where the blower door was located, the indoor radon concentration dropped more quickly than that of room 1. This is because the operating of the blower door in room 4 directly affected the indoor radon concentration more than that of room 1. It is concluded that indoor radon concentrations are affected strongly by pressure changes.

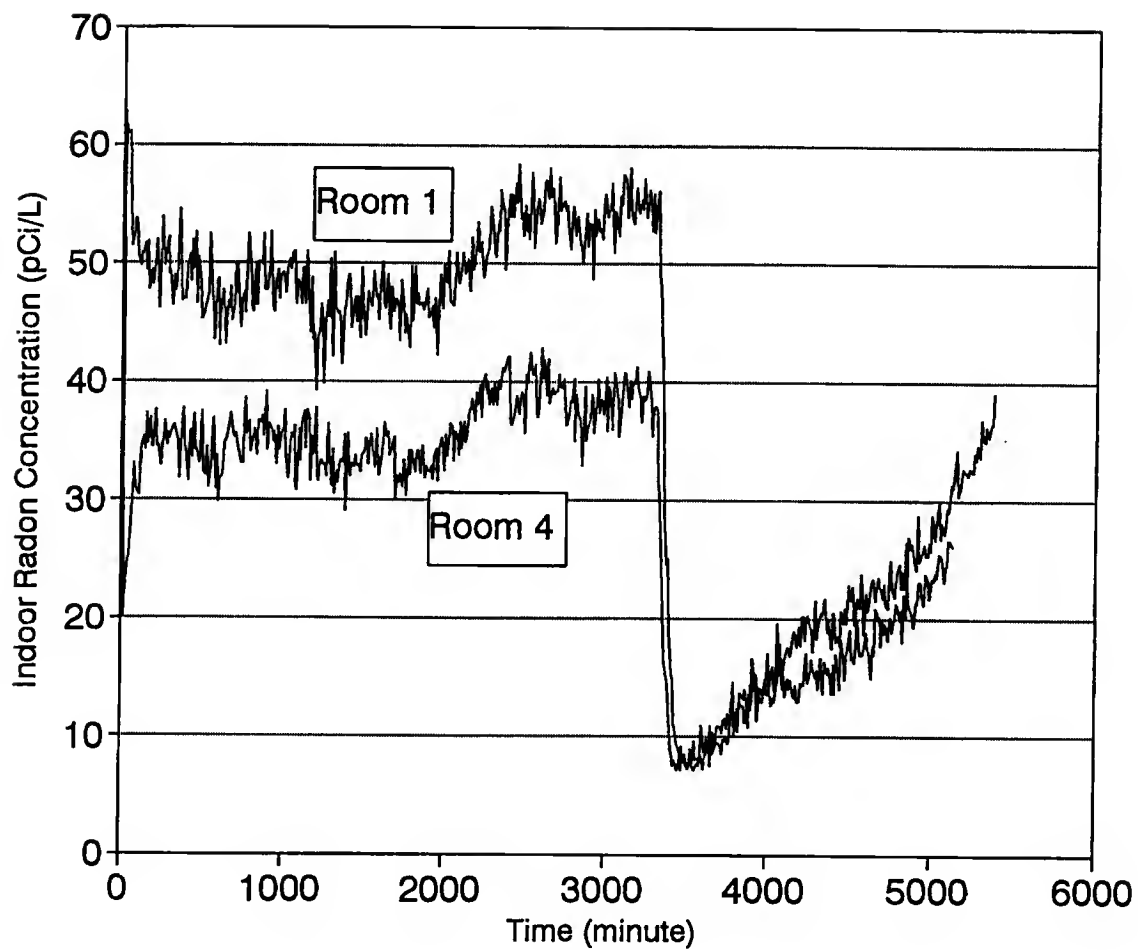

Figure 4.11 Radon Concentrations with Respect to Pressure Changes

Summary

Radon concentration is affected by many factors and it is usually laborious to control. Through the research projects of UF, no significant factor influencing radon intrusion was found. However, the research results show a satisfactory way to reduce radon entry. These mitigation methods employed by UF have effectively reduced indoor radon to an acceptable level. The passive barrier is successful for constructing a radon resistant house, and it is commercially feasible.



## CHAPTER 5 CONSTRUCTION METHODS

### Introduction

There have been many methods proposed for reducing indoor radon. The improved reduction methods based on previous research which were applied in the UF research projects include the Enkavent mat and suction pit methods. These methods are easy to follow and cost a minimum. Other methods, such as HVAC and perforated pipe methods, are being investigated.

### State-Of-The-Art Construction Mitigation Methods

Most efficient applications in reducing raised indoor radon concentrations are utilizing of Active Soil Ventilation and Depressurization (ASV&D) systems [HRS 1988]. Although many other methods have been employed in reducing and mitigating elevated indoor radon concentration, ASV&D systems are the most widely used and commercially available systems. The principal concept of ASV&D systems is by creating a low pressure area underneath the building structure [Al-Ahmady and Hintenlang 1994b]. Radon-rich soil gas, the major source of elevated indoor radon concentrations, may then be forced into the low

pressure area and exhausted outdoors. Furthermore, Subslab Depressurization systems are the most effective, cost feasible and widely used ASV&V systems.

The research projects of UF applied the SSD systems by passive and active approaches. The passive approach utilizes construction techniques to reduce the rate of radon entry. These techniques include installing vapor barriers underneath the floor slab, proper sealing of plumbing penetrations and slab cracks, and installing radon mitigation systems in the house. If the passive approach is not successful in reducing indoor radon to an acceptable level, then the active approach could be applied. The active approach is simply using a fan or fans to depressurize the air below the slab. The Enkavent mat and suction pit methods were applied by UF on the new house evaluation program. These two methods are considered the state-of-the-art construction mitigation methods.

#### Enkavent Mat Method

The Enkavent mat is designed for subslab depressurization. It provides an airspace to intercept radon before it seeps into the basement, crawl space, or through the floor slab. The mat is a 0.8-inch high matrix of nylon filaments point-bonded to a polyester filter fabric, and 90% of the geometry is airspace to provide room for radon to flow. The mat is stiff enough to support concrete without compressing, and it is lightweight enough for easy handling.

This mat system allows the radon to flow through the filter fabric and into the airspace. The airspace does not clog because of a filter fabric which lies above the gravel and soil. The natural airflow through the Enkavent mat then channels the radon into pipe openings. The mat is about 18 inches wide and comes in 100-ft rolls. The placement of the Enkavent mat is illustrated in Figure 5.1.

#### Installation Procedures

A two-inch vent pipe is placed on the Enkavent mat and extended through the roof. To prevent rain and pollutants from entering the vent pipe, a cap is installed at the end. The vent pipe carries subslab radon to the roof and ventilates it. The mat strips should be oriented along the central axis of the longest dimension of the slab or diagonally across the slab. It is necessary to provide one mat strip for every 50 feet of slab width. Mat placement should start at a distance of 6 feet or more from the slab edge. The pipe should be centrally located along the length of each mat strip. Also, one pipe should be provided for every 100 feet of mat length [DCA 1993]. Two typical layouts are shown in Figure 5.2.

#### Suction Pit Method

The suction pit method is similar to the Enkavent mat method. The open pit and gravel pit are available in construction practices. The open pit has a semi-spherical hole, 32 inches in diameter, and 16 inches deep.

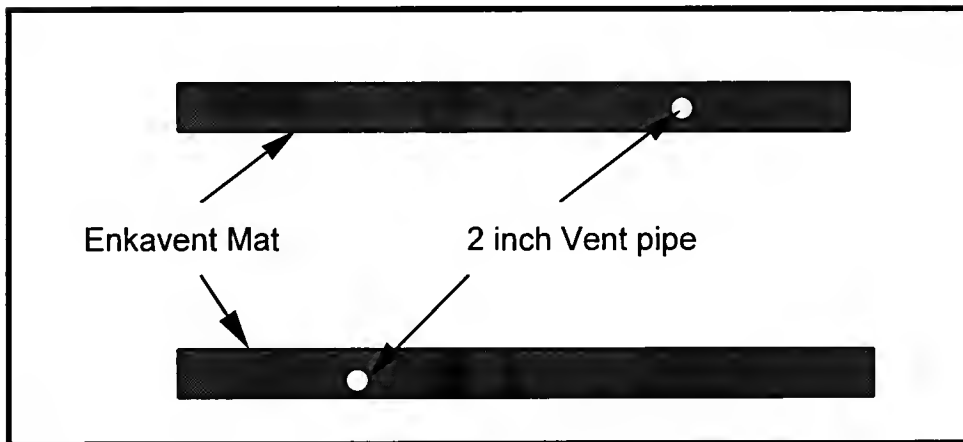
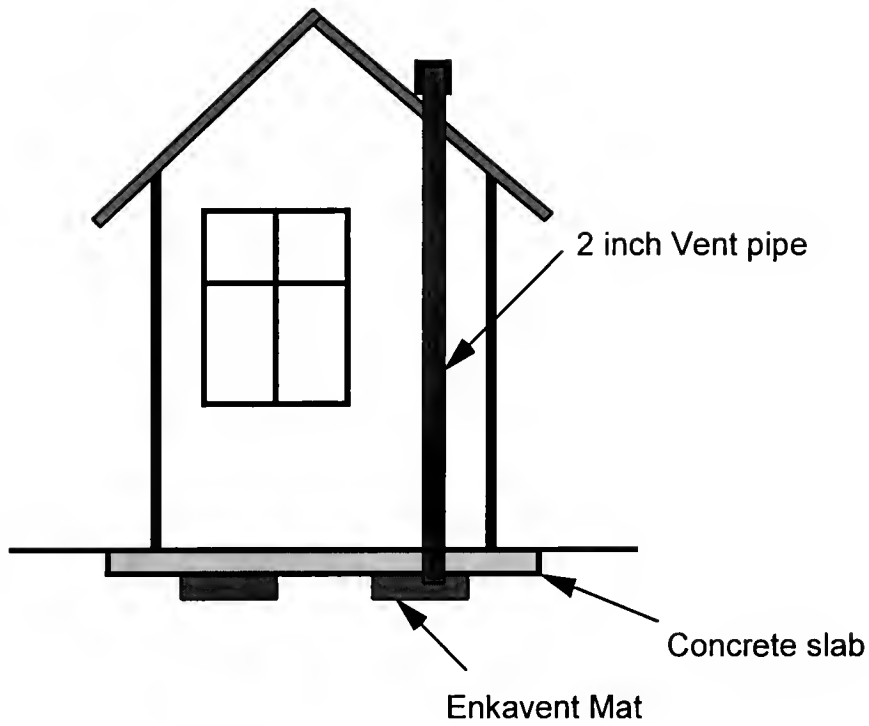
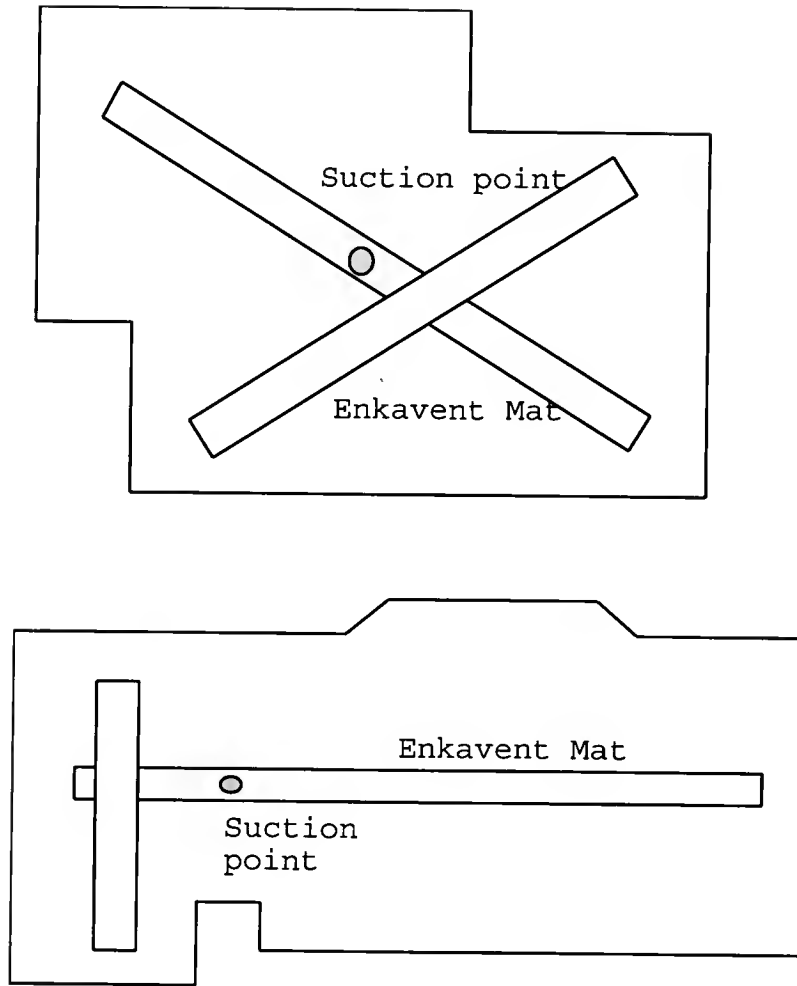

Figure 5.1 Enkavent Mat Placement



Note: Drawn not to scale

Figure 5.2 Typical Enkavent Mat Layouts

Moreover, a vent pipe connects to the roof. The vent pipe is placed vertically in an interior wall or a closet and has a steel plate that covers the top of the pit. The two-inch vent pipe to connect the pit is at a slope of 1/4-inch per foot horizontally. It is necessary to provide one two-inch vent pipe for each pit. The gravel pit is the same as the open pit except the pit is filled with gravel and does not have a steel cover on top of it. The gravel pit could be a better method because the open pit might allow insects to live inside it; and possibly due to rain or earth movement or water table changes, the vent pipe might become obstructed. A gravel pit is illustrated in Figure 5.3.

#### Perforated Pipe Method

A perforated pipe can be substituted in the Enkavent mat or suction pit method since its coverage area is larger than the suction pit method and the cost of materials is much cheaper than the Enkavent mat. The new house evaluation projects have not employed the perforated pipe yet. But at the large building project of 1994 it was installed for experimentation. Based on the engineers' judgment, it could be an alternative method for subslab radon depressurization.

#### Mechanical Barrier

Since most radon gas comes from gaps of soil-foundation interfaces, it is desirable to reduce the entry by

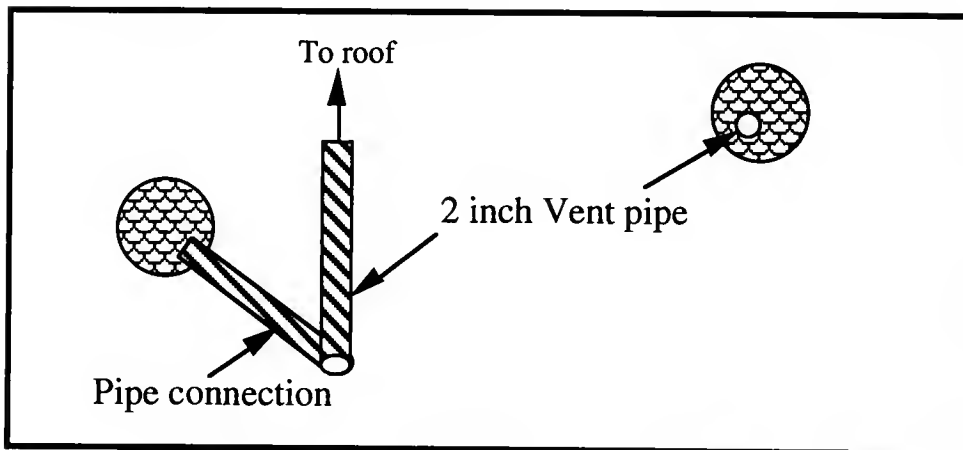
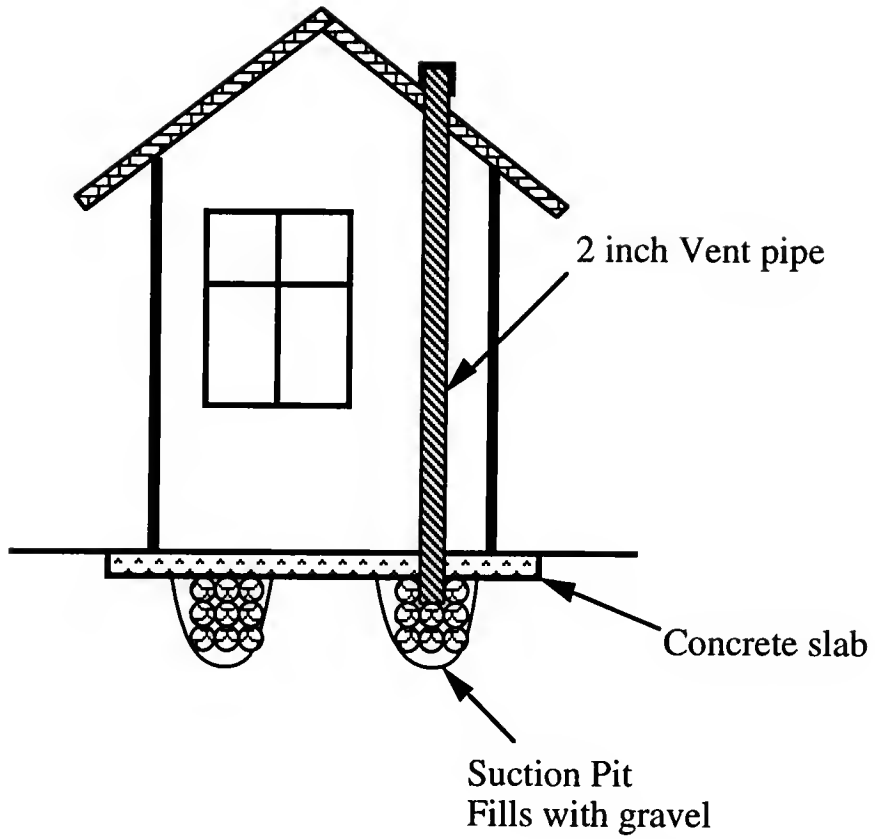

Figure 5.3 Suction Pit Placement

reinforcing the interfaces. The mechanical barrier can be applied to most of the below-grade houses to prevent radon entry in an effective manner. The mechanical barrier is illustrated in Figure 5.4.

The following is a list of recommendations suggested by the EPA, by which builders can utilize the foundation as a mechanical barrier to radon entry [EPA 1991, p.10-11].

A) Foundation walls and floor slabs are often constructed of poured concrete. Plastic shrinkage, and therefore cracking, is a natural function of the drying process of concrete. Many factors, such as the water/cement/aggregate ratio, humidity, and temperature, influence the amount of cracking that occurs in a poured concrete foundation.

Cracking may be minimized by

- 1) proper preparation, mixture, and curing of concrete;
- 2) ferrous reinforcing (rebar rods and woven wire meshes);
- 3) use of concrete additives to change the characteristics of concrete;
- 4) water reducing plasticizers, fiber-reinforced cements.

B) To help prevent cracking in masonry walls, or minimize the effects of cracks that do develop

- 1) use correct thickness of unit for depth of soil;
- 2) use ferrous reinforcing (corners, joints top course);
- 3) coat interior and exterior of wall with damp-proofing.



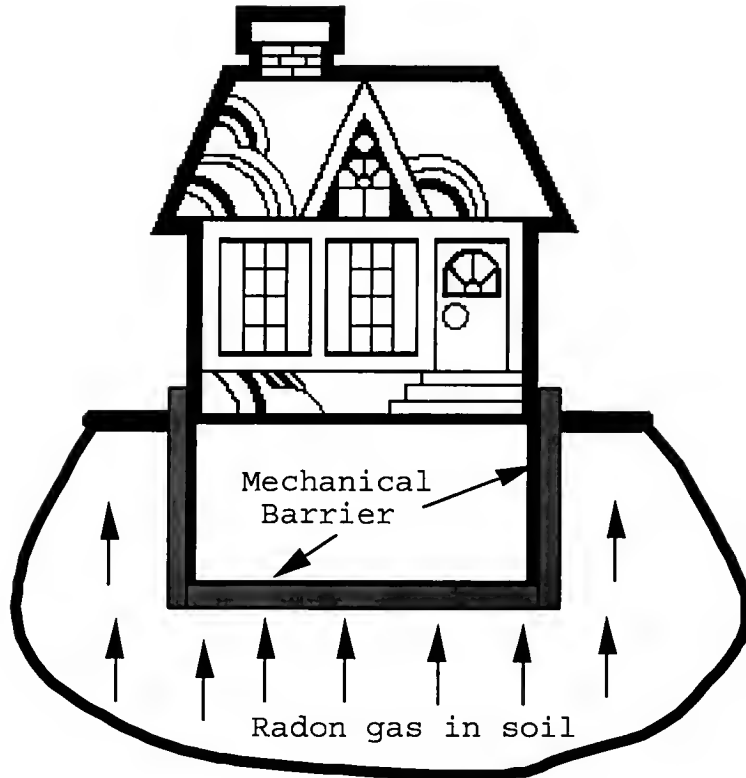

Figure 5.4 Mechanical Barrier  
Modified from [EPA 1991]

C) Cracks and joints in concrete and concrete block can be sealed using caulks. Polyurethane caulks have many of the properties required for durable closure of cracks in concrete. The properties are: durability, abrasion resistance, flexibility, adhesion, simple surface preparation, acceptable health and safety impacts. Typical points should be sealed with caulks at

- 1) plumbing penetrations (soil pipes and water lines as minimum);
- 2) perimeter slab/wall crack and expansion joints.

D) The open tops of concrete block walls are openings that should be sealed. This can be done by installing a row of the solid blocks, lintel blocks or termite cap blocks at the top of the wall. In addition, applying of damp-proofing and waterproofing materials on the exterior, interior, or both sides of the foundation that can serve as a radon resistant barrier is recommended to help control radon entry. It should be made clear that a coating applied to a foundation intended to resist the flow of radon into a building is in addition to the normal water-proofing/damp-proofing requirements. Coatings are applied to the outside or inside of the foundation, creating a radon-resistant barrier between the source and the inside of the house. The vapor membrane is recommended for applying to the exterior of the foundation and also beneath the floor slab during construction.

#### Change of Foundation Soil

Radon gas can travel in the soil approximately one to four meters by diffusion before 90 percent of it decays. The traveling distance can be increased by geothermal gradients, water table levels, and pressure differentials between soil and the earth's surface [Landman 1982]. Assume that the soil to be changed is at a depth of 5 feet, and house floor area is 3048 ft<sup>2</sup>. Also assume that 5 feet beyond the perimeter of the floor is to be excavated. Therefore, the total soil to be changed is 667 yard<sup>3</sup>. The total cost of

the changing soil is illustrated in Table 5.1 [Means 1993]. The cost of changing the soil is estimated to be \$14,774. It is not feasible to apply such a method because the cost is too high, and it might be difficult to find suitable soil.

Table 5.1 Soil Changing Analysis

Item	Code #	Description	Unit Cost/yd <sup>3</sup>
1	022-242-2020	Excavation	1.83
2	022-266-0540	Hauling	6.80
3	022-212-0800	Barrow Soil, 5-mile haul	11.47
4	022-204-2200	Compaction	2.05
		Subtotal	22.15
Total Cost		14,774	

#### Fill Materials or Layered Natural Soils

Natural earthen materials under buildings whose radiological properties vary significantly with depth, or fill materials that are placed directly under the building or within 10 feet of the building perimeter, should result in radon concentrations in the air around the soil that are less than those given in Figure 5.5 [ACRES 1990]. Building sites shown to have less than 600 pCi/L of soil gas radon should be considered to be in compliance with this change of soil.

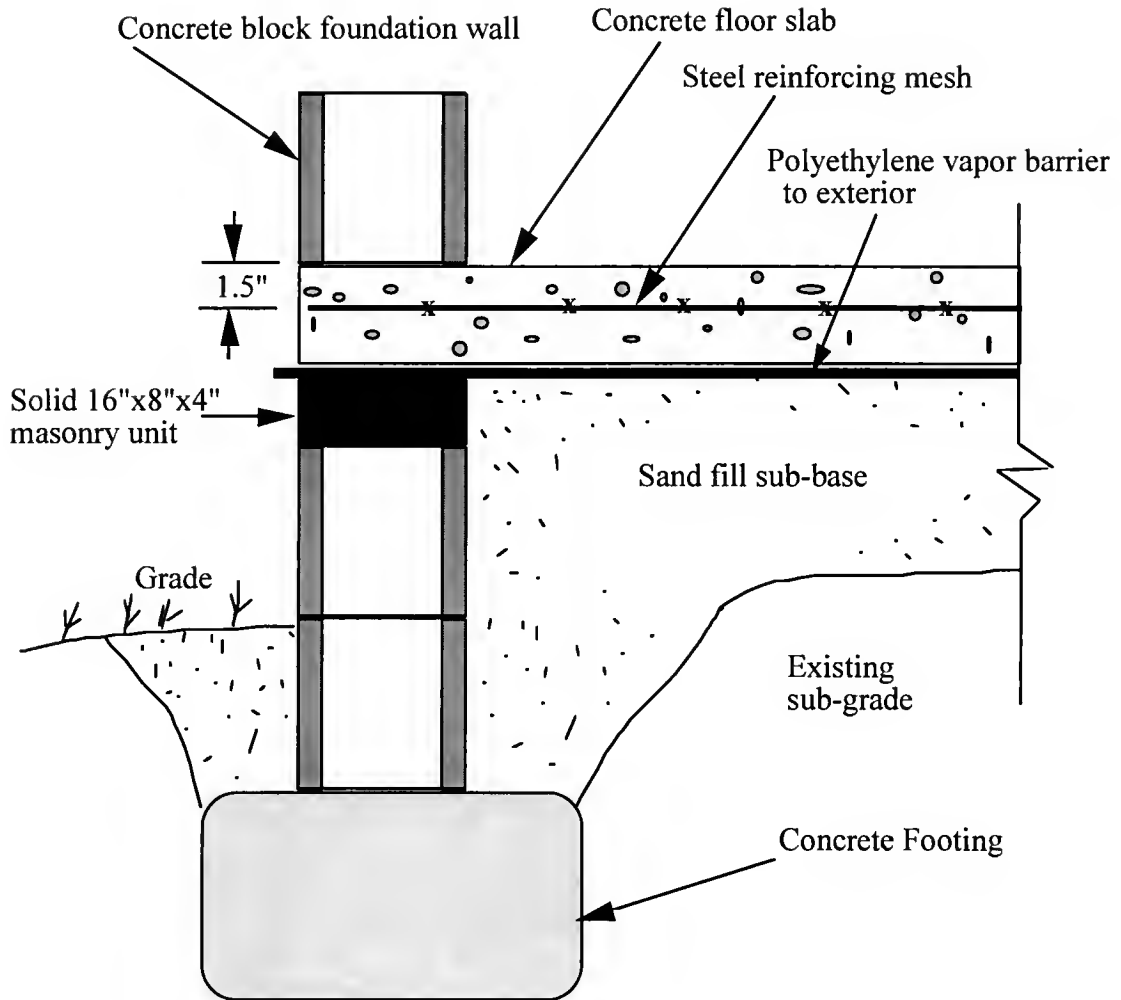

Figure 5.5 Solid Concrete Block Barrier and Vapor Barrier Installation Layout

Modified from [ACRES 1990]

### Construction Materials

Foundation backfill materials shall have radium concentrations less than 0.8 pCi/g. All materials used in concrete for the construction of habitable structures shall

have a radium concentration of 5 pCi/g or less. Supposedly, assuming that the conditioned space of a house is replaced with low radium soil of high compaction to a depth of eight feet, the radon entry could be reduced [Rogers and Nielson 1991b].

### Cost Comparisons

The cost of the Enkavent mat and suction pit installation are estimated in terms of material and labor costs. The estimated costs of the Enkavent mat system are listed in Table 5.2 and suction pit costs are in Table 5.3 [Shanker 1993]. The total estimated Enkavent mat costs is higher than the total suction pit cost because the material costs of Enkavent mat are far more expensive than that of the suction pit. The cost of changing the foundation soil is far more expensive than the cost of the two mitigation methods. In addition, the low radium content soil may not be available in a specific area. Therefore, changing of the foundation soil is not recommended for application. The costs of Enkavent mat or suction pit methods are around \$1000. In comparing this amount to the cost of the new house, it is relatively small.

### Planned Mechanical Systems

The entry of soil gas into buildings is the result of an interaction between the house shell, the mechanical system, the climate, and the foundation soil. The important

Table 5.2 Costs of the Enkavent Mat System

Average cost for Enkavent Mat system installation	House area = 3048 (ft <sup>2</sup> )	
Items	Material costs (\$)	Labor cost (\$)
Enkavent Mat installation	244	6
PVC supplies (pipe, flanges, bends, T's Y's etc.)	50.82	6
Tar (asphalt)	70	12
Curing compound	47.15	3
Elastomeric sealants	49.7	12
Superplasticizers	245	0
Subtotal	707	39
Total	746	

Table 5.3 Costs of the Suction Pit System

Average cost for gravel pit system installation	House area = 3048 (ft <sup>2</sup> )	
Items	Material costs (\$)	Labor cost (\$)
Construction of pits	12	9
PVC supplies (pipe, flanges, bends, T's Y's etc.)	50.82	6
Tar (asphalt)	70	12
Curing compound	47.15	3
Elastomeric sealants	49.7	12
Superplasticizers	245	0
Subtotal	474.67	42
Total	517	

climatic factors which can significantly affect radon entry are the windspeed, temperature changes, watertable, and atmospheric pressure changes. Indoor radon concentrations may be reduced by planning the mechanical system so that fresh air dilutes the radon that has entered the house, and by controlling interior air pressures to reduce soil gas entry. This approach has not been extensively tested in the EPA Demonstration Projects in existing houses. The disadvantage of this approach is that it is both more comprehensive in effect and more complex in design and installation than the other techniques. The installation of such a system should be pursued by qualified people who have training and experience in mechanical systems, because it is a more sophisticated control strategy than a soil depressurization system [EPA 1991].

#### A New Radon Mitigation Method

In the fall of 1993, a study was conducted concerning the feasibility of using an applied electric field to induce a barrier to soil gas migration, in order to prevent the entry of soil-gas-borne contaminants such as radon, pesticides, biological agents, and organic compounds into buildings [EPA 1994]. Figure 5.6 illustrates this new technology. Numerous studies have shown that the air permeability of the soil is the most important single factor influencing the transport of soil radon into structures. Studies have also shown that the level of moisture contained



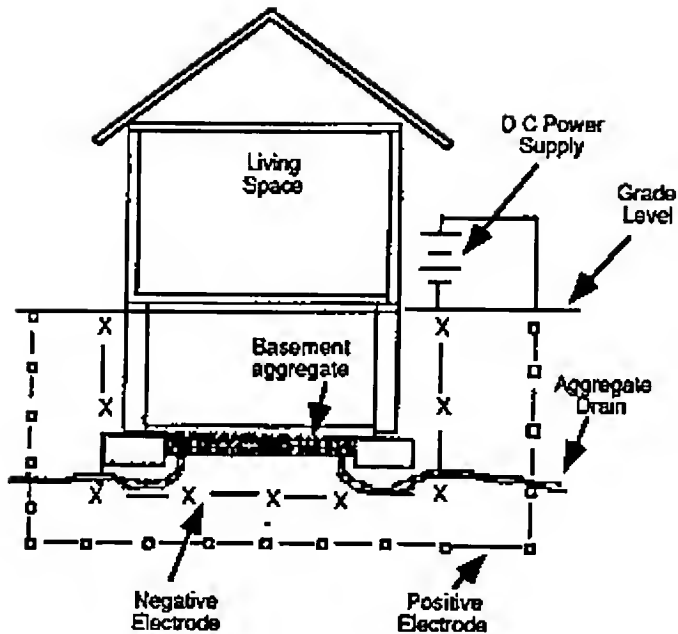

Figure 5.6 A Schematic Illustrating the Application of an Electrically Induced Soil-Gas Barrier [EPA 1994]

in the vadose zone (the zone of soil above the permanent water table that contains both moisture and air) has a profound influence on the permeability and diffusivity of the soil. When the soil is fully saturated with water, migration of contaminants is very limited. In many soils, a 20% increase in moisture will result in a 70% reduction in contaminant transportation.

This new technology uses an electric field to generate and maintain a layer of moisture in the soil, thus lowering the permeability and diffusivity of the soil surrounding the substructure of a building. An applied electric field induces movement of water in soil because the water contains

ions (usually positive) that have been released into solution by the soil particles. When these ions move under the action to the electric field, they tend to drag the water droplets along with them. This results in motion of water toward the cathode (negative electrode). When sufficient water has been moved toward the cathode, a zone depleted of water develops near the anode. As this depleted zone develops, the current will decrease because fewer charge carriers are available near the anode. In an ideal case, the current would go to zero while the static field maintained a layer of high moisture content near the cathode. Under these ideal conditions, no electrical energy would be required to sustain the layer that forms a barrier to the movement of soil contaminants.

This new technology could be less costly than conventional methods and may be applicable in regions of the country where conventional methods are not successful.

#### Summary

This chapter reviews the modern experimental radon mitigation systems. The practical mitigation systems are discussed in the preceding text. In addition, a new mitigation system which is still under investigation is discussed. Enkavent mat and suction pit methods are commercially available and are by far the most popular and successful mitigation methods to date.

CHAPTER 6  
ESTABLISHMENT OF KNOWLEDGE BASE

Introduction

This chapter describes the computer-aided design tool in construction for preventing radon intrusion. The procedures and materials used for constructing a radon resistant house are introduced.

The object-oriented databases were established in conjunction with the MacSmarts expert system. The databases were based on intensive experiments from previous research and the Environmental Protection Agency's suggested methods and standards.

The Radon Information System (RIS) is developed to diagnose radon problems and also to provide information available upon request. This user-friendly system is able to assist contractors, homeowners, and designers in obtaining suggested information.

Mitigation methods, cost estimation, materials used, construction procedures, radon regulation, and construction scheduling are included in the system. In addition, graphical construction procedures to install the mitigation systems, crack analysis, slab construction and a potential radon index are also incorporated in the system.

### Effective Information Retrieving

Most recent radon knowledge is difficult to retrieve. There have been many research projects in the United States to prevent radon intrusion. Radon papers have been published in journals and conference proceedings; however, radon knowledge is not organized. This knowledge can be presented in a way that could be more useful for users. The users could be the general public, contractors, builders or researchers. If this information could be organized properly, it would result in a shorter retrieval time, and promote the interest of the user. Therefore, RIS is developed to assist radon information consulting.

### Expert System Applications

Primary managers should consider using expert systems because they are an aid to decision making. Expert systems are concerned with knowledge but not data. Here, an individual's relevant knowledge and experience can be incorporated into a computer program. This knowledge can be accessed quickly and easily by a manager to improve the quality of decision making.

### Advantages of Managing Radon Information by Expert Systems

The advantages of using Expert Systems applications are:

- 1) The knowledge is permanent and will not fade in time;

- 2) It is easy to transfer the knowledge to any number of users provided they have a compatible computer;
- 3) The knowledge base can generate the data in a well organized structure;
- 4) The cost of expert, senior consultants is expensive. Incorporating their knowledge in an expert system is desirable, because it can be used at any time [Bryant 1988].

The decision making rules or tables of the expert system are defined as "knowledge base."

#### Performance Improvement and Knowledge Transferring through Expert Systems

Since radon projects generate substantial information, it is necessary to have a computer-based system to manage them. An expert system could be an essential management tool. A good tool can be a positive management asset. Improving the productivity of employees in an organization is an essential endeavor upon which management lays a great deal of emphasis. It is a well recognized fact that we all aspire to work smarter rather than harder. The greatest value of an expert system is that it provides people with an opportunity to enhance their performance. Performance improvements come about, among other things, as a result of

- 1) The opportunity to access expert advice at any time;
- 2) The ability to query the expert's reasoning, and to go over it again and again in order to understand the

underlying logic. No expert would have the time or the patience to be questioned in this fashion;

3) The ability to obtain consistent advice regardless of the emotional or political aspects surrounding the query;

4) The opportunity to change, amend and expand the rule-base so as to enhance the performance of the system.

Gaining experience is a time consuming, sometimes traumatic, and often very expensive process. Expert systems provide people with the opportunity to gain experience at a fast rate with far less cost [Beerel 1987].

### The Structure of Knowledge-Based Expert Systems

The basic structure of a knowledge-based expert system (KBES) is shown in Figure 6.1. The components include the following [Dym and Levitt 1992]:

1) Input/output facilities that allow the user to communicate with the system and to create and use a database for the specific case at hand;

2) A working memory that contains the specific problem data intermediate to the final results produced by the system;

3) An inference engine that incorporates reasoning methods, which in turn acts upon the input data and the knowledge in the knowledge base to solve the stated problem and produce an explanation for the solution;

4) A knowledge base that contains the basic knowledge of the domain, including facts, beliefs, and so on;

5) A knowledge acquisition facility that allows the KBES to

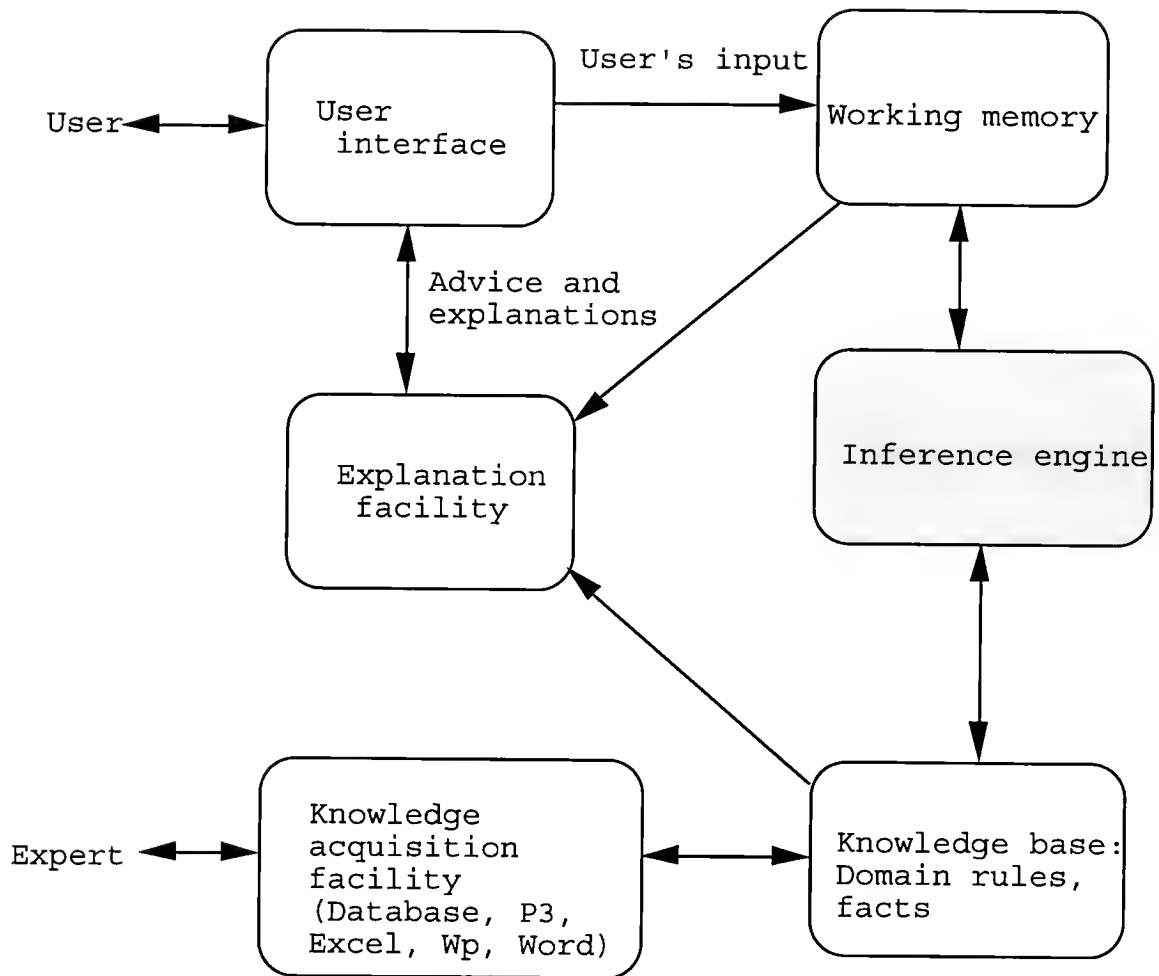

Figure 6.1 The Basic Structure of a Knowledge-based Expert System

acquire further knowledge about the problem domain from experts or automatically from libraries, databases, etc.

### Objective of the Knowledge Base Development

Radon knowledge can be encapsulated in a computer program and accessed quickly, inexpensively and easily by any person to improve decision making. Therefore, RIS is developed for radon knowledge retrieving. RIS captures years of learning, experience, and research results.

Radon problems have been researched for more than a decade; however, the results and findings are not stored and organized properly. If these findings and suggestions can be saved on a computer, people can share them more easily. These facts can be transformed into knowledge bases. RIS utilizes these facts to aid decision making or even research. In the past, the difficulty in obtaining current up-to-date knowledge was frustrating. Now the layman, i.e., the homeowner, contractor and researcher can, access the state-of-the-art information available from the system.

The purpose of the system is to facilitate information retrieval and decision making. This knowledge base is established for the target users. The system is designed to direct suitable knowledge to each of the users. The knowledge base is founded on previous research results and expert experience and suggestions. Hypercard is selected to perform this task because it provides an interface between the spreadsheet, database, word processor, and expert



system. In addition, its graphical presentation ability is suitable for object-oriented programming. The research procedures are illustrated in Figure 6.2.

### Knowledge Acquisition

There have been many research projects and laboratory experiments throughout the United States to investigate radon mitigation methods, radon behavior, and the factors that affect radon entry. This research utilizes the most recently published methods and radon related treatment subjects. In addition, the results of FRRP which have been accumulated since 1991 are incorporated into the knowledge base.

The knowledge base is mainly from EPA & FRRP because they are two of the leading research agencies working on radon-related problems. The FRRP results could be the most up-to-date since its research applied a revised methodology based on previous experimental experience. Most radon techniques obtained are from the EPA's publications or related research reports.

### Selection of Knowledge Domain

The scope of this system is to provide homeowners, builders, contractors, and researchers with necessary radon information for constructing radon resistant buildings. The knowledge should be suitable for different users in different domains. The system includes construction

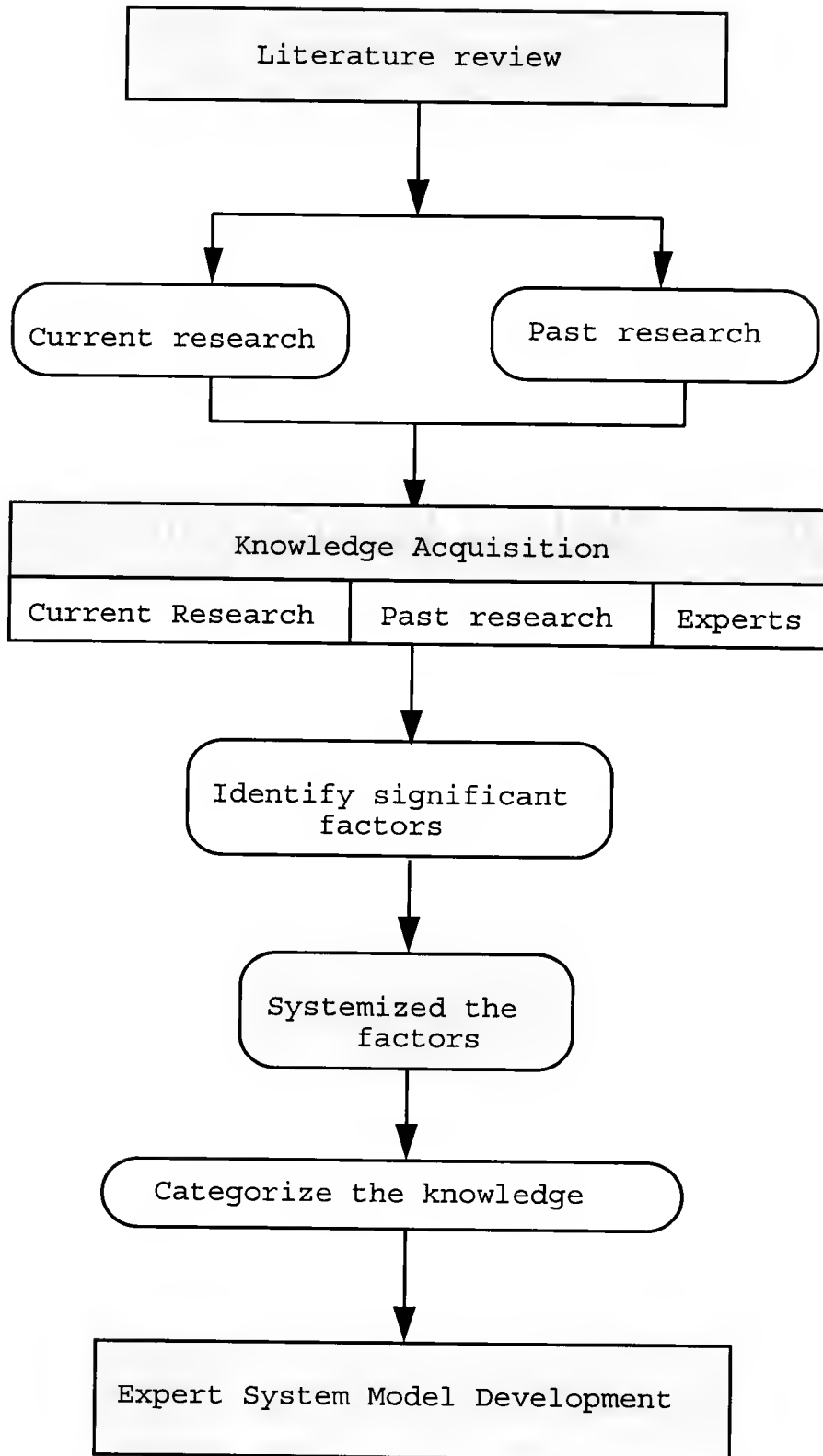

Figure 6.2 Knowledge Base Expert System Establishment Procedures

techniques in new houses, radon mitigation standards, radon regulations, radon potential index, mitigators, governmental agencies, radon treatment, and so on.

The construction methods are mostly from recent University of Florida research projects and EPA publications. The UF research results have been very successful in reducing indoor radon concentrations below the Department of Community Affairs standard [DCA 1991]. Construction design and mitigation methods are established in the knowledge base. Construction mitigation methods are fully described in the knowledge base. A short description includes construction procedures, materials, control joints, vapor barrier placement, and wall-slab connections. The installation costs of the mitigation systems are also included.

#### Control Mechanism of This System

An interface software is selected as the control panel of this system. Hypercard is a suitable software for this object-oriented radon database. It provides information retrieval, spreadsheets access, and expert system linkage. The information can be sent or received through the interface of the modules. A schematic diagram of the system is illustrated in Figure 6.3.

#### Database Development

The database should be established according to

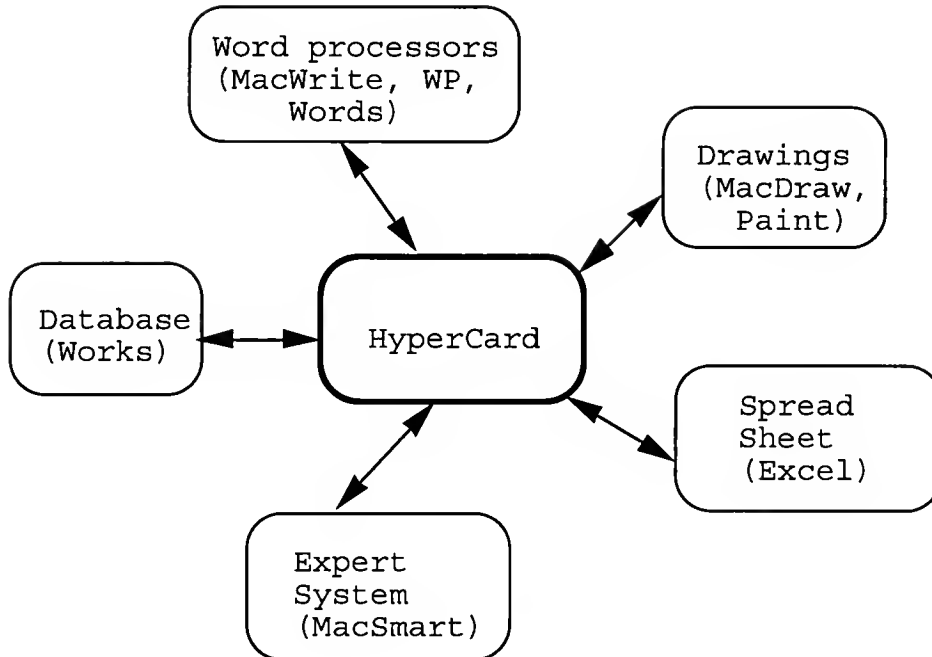

Figure 6.3 Schematic Diagram of the Interface System

the target users. Since an expert system can only solve in a narrow domain, the scope of the system should be carefully delineated.

#### Identify Target Users

The system is designed for homeowners, builders/contractors, and researchers. Each user has its specific needs; therefore, information provided for each user is different.

#### Establish Problem Boundaries

The scope of the database is limited to three target users. All target users have their own knowledge boundaries

in order to be suitably applied. These boundaries for each target user are described as follows.

Homeowner Boundary The information provided for homeowners on radon is based on general information. The subjects selected have been modified by interviewing several homeowners and potential home buyers. The information includes:

- 1) health related information
- 2) acceptable radon level
- 3) new house standards
- 4) cost of radon testing and mitigation systems
- 5) mitigators' addresses
- 6) addresses of governmental agencies.

Contractor Boundary The information for builders or contractors includes

- 1) radon mitigation methods
- 2) mitigation costs
- 3) radon regulation
- 4) new house standards
- 5) addresses of governmental agencies
- 6) feasibility of radon mitigation installation.
- 7) indoor radon prediction

Research Boundary The information that researchers frequently consult includes

- 1) mitigation systems

- 2) research projects
- 3) mitigation updates
- 4) research results
- 5) addresses of governmental agencies
- 6) radon journal or database
- 7) indoor radon prediction.

### Obtain Expert Support

Most radon knowledge is based on accumulated experience from previous research projects, experimental results, and theoretical papers. This knowledge has been revised according to new research findings. However, many research projects have inconclusive results. The system focused fundamentally on the general subjects that most researchers agree upon and were published in journals or conference proceedings. Also, the system incorporated much information from the UF research projects. Since radon knowledge is very subjective and difficult to extract from papers where integrity of information is questionable, the knowledge from experts is valuable. The experts from UF and radon conferences were the primary sources of that knowledge. Their experience and suggestions were incorporated into the systems.

### Organize the Facts from the Knowledge Databases

The knowledge obtained was classified into general text, spreadsheet files, pictures, and regulations.

General Text Includes information that can be expressed in a few sentences, such as the introduction to radon gas and what you should do about radon and radon levels.

Spreadsheet File The information is best expressed in spreadsheet format. For example, soil permeability, soil radium content and average county indoor radon levels. This program uses "Excel" to contain large data sets.

Picture File Information is most suitable for explanation in pictures. Pictures can help verbal explanations and provide visual aid. Most pictures are obtained by the scanning of original pictures or by drawing tools (MacDraw, Macpaint).

Regulations Radon regulations are provided in separate files because the information is enormous. The databases contain general definitions and descriptions of radon gas. Also, they provide radon mitigation methods and construction costs. Most of the databases are from the EPA's publications. Because the information is huge, the databases are designed in scrolling type. However, the databases provide a "Find" command which can retrieve any subject upon the user's request. For example, Mitigation Standards and New House Construction Standards are two regulation databases.

A database is not limited to one kind of format. It has a combination of two or three of them. Hypercard is the main control unit. It directs the designed function to act for

the user. However, the linkage between all databases makes information retrieval flexible.

### Design Rules

Most of the knowledge bases are subject-oriented; therefore, the traditional rule-bases were used as an assistance to the programming. The rules were designed within the databases to act according to their specific tasks. These rules also control the linkage between databases and spreadsheets or expert systems.

Hypercard has its own programming language, Hypertalk. Hypertalk controls the overall functions of the system. A basic Hypercard structure is illustrated in Figure 6.4. Stack, card, background, button, and field are the elements of the hierarchical structure of Hypercard.

Entity Relationship Data Diagram The entity relationship diagram is shown in Figure 6.5. A stack may have many cards (one to many, 1:M); a card may have many buttons and/or fields (one to many, 1:M). However, a button or field belongs only to a card; a card belongs only to a stack. This top-down hierarchical structure is most suitable for information organizing and retrieval.

Data Manipulation Data may be transferred between stacks, cards and fields. Specifically, data may be transferred from one card to other, or stacks. A schematic diagram of data transferring between stack, card and field is illustrated in Figure 6.6.



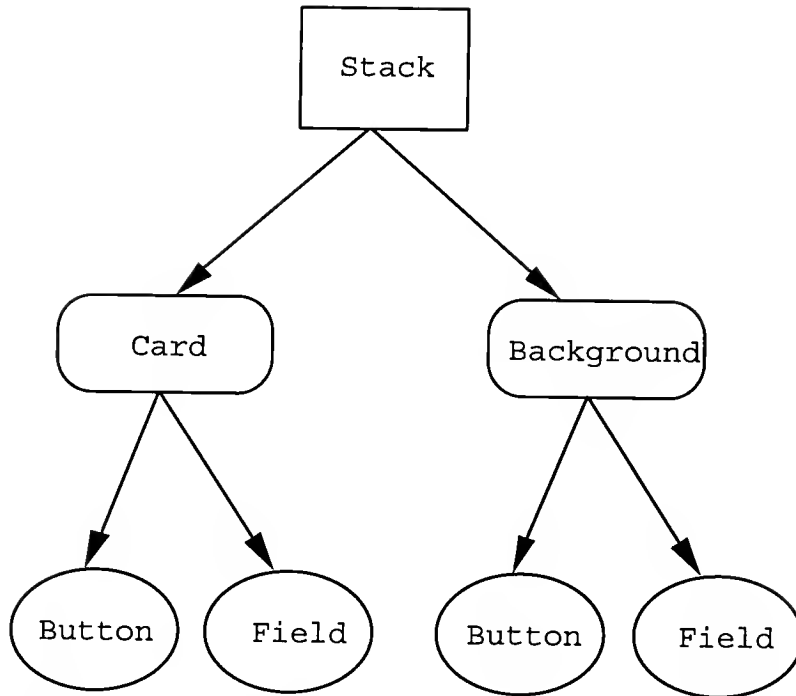

Figure 6.4 Hierarchical Structure of Hypercard

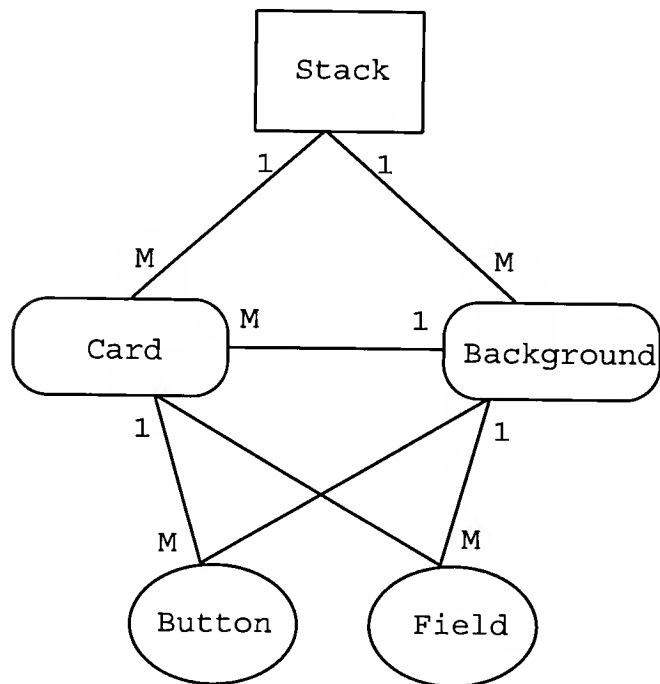

Figure 6.5 Entity Relationship Diagram of Hypercard Elements

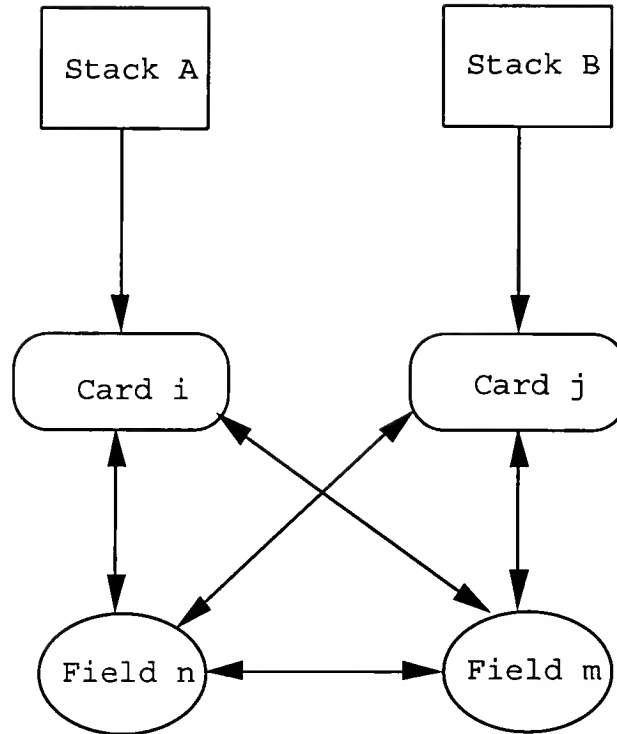

Figure 6.6 Data Transferring Between Stacks

### System Development

As mentioned previously, the system uses Hypercard as the central control unit. Hypercard is designed to respond to the users' requests. This user-friendly Hypercard provides easy access tools to users. The system contains three major parts: Homeowner, contractor and researcher databases. The menu of the system is shown in Figure 6.7.

### Homeowner Database

Homeowner database contains general information about radon gas and is specifically designed for homeowners. Homeowner database is shown in Figure 6.8.

Since radon problems have not been brought to the serious attention of the general public yet, the information provided is modified to the broad and general topics of radon. The information provided for homeowners is fundamental and its contents are essential for the general public. The database contains the most frequently asked questions and their answers.

Figure 6.8 shows the hierarchical flow chart of the homeowner database. The homeowner database acts like a liaison between all functional features. The key features of the homeowner database are described as follows:

What Is Radon? This file contains the necessary information that a homeowner should know about radon. The sources of radon gas, how radon gas enters houses, and the critical radon action levels are all detailed in this file.

Mitigation Standards The action levels of radon concentration are established by several agencies. The action level is the critical radon concentration that may cause lung cancer. Because the EPA has been conducting many serious research projects, the standards set by the EPA are considered the most definitive in the radon field. The action level is 4 pCi/L under EPA's standard. Action levels of other agencies, such as the National Council on Radiation, protection and measurement (8 pCi/L), Bonneville Power Administration (5 pCi/L), American Society of Heating, Refrigeration and Air Conditioning Engineers (2 pCi/L) and Sweden (4 pCi/L) are listed as well.

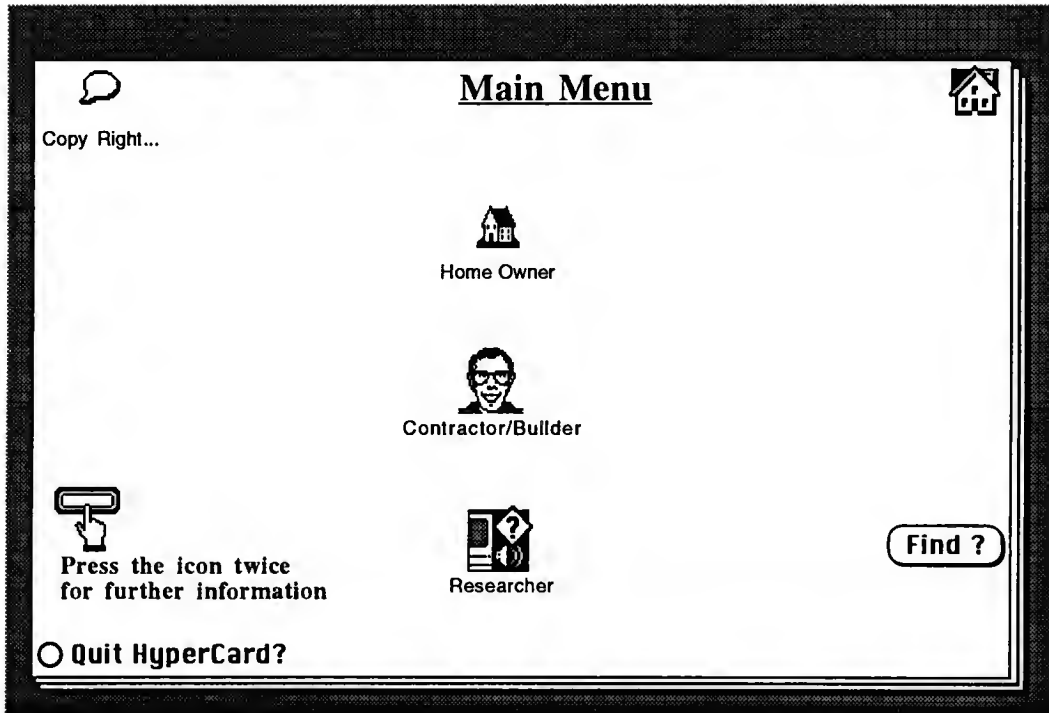

Figure 6.7 Illustration of System Menu

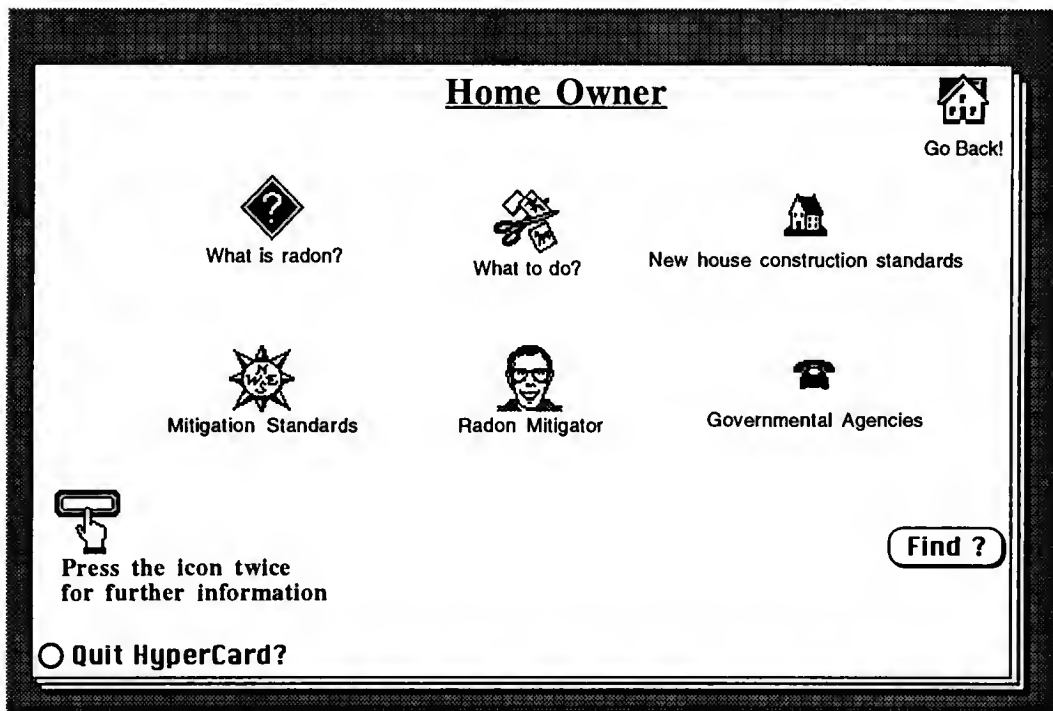

Figure 6.8 Key Elements of Homeowner Database

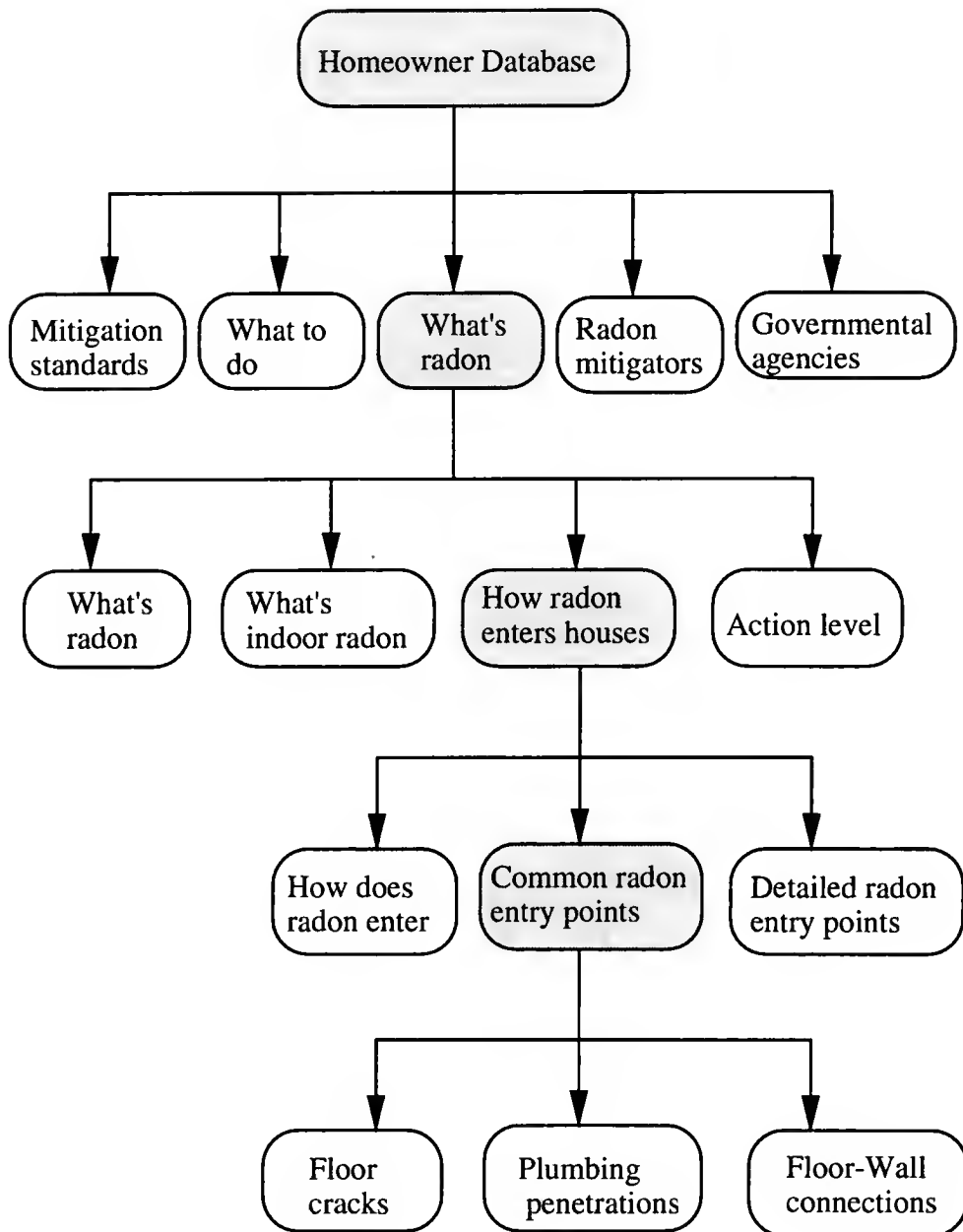

Figure 6.9 Hierarchical Flow Chart of Homeowner Database

What To Do? The biggest concern of homeowners is what to do about radon problems. This file has suggestions for the treatment of radon problems. Radon problems can be solved by contacting a local radon testing company or buying a radon testing kit or contacting governmental agencies.

Radon Mitigator The knowledge base has a list of radon mitigators for homeowners to consult. The listed radon mitigators are mostly located in Florida. A big company usually provides better quality. Homeowners can use the "Find" function to search for a desired mitigator. The knowledge base has function keys on each of the cards to assist users.

New House Construction Standards This file is a reference for homeowners. It contains the descriptions, regulations and suggestions of the new house construction. However, radon regulations have been revised and tested in research projects.

Governmental Agencies Each state has a person to consult. The contact person or agencies in each state are documented in this file. The user can enter a state name in the dialog box and find information for a specific state. This file includes all the states in the United States.

#### Contractor Database

This database focuses on the radon mitigation methods, constructability, materials, costs, radon resistant floor-slab construction drawings, crack prevention, radon content

in construction materials, and indoor radon prediction. Contractor database is illustrated in Figure 6.10. The key knowledge bases are presented in Appendix C. The major elements are described as follows:

Indoor Radon Prediction Indoor radon may be predicted by a model which is based on the experience and the results from previous projects. The model is based on five factors (average area indoor radon, aerial radioactivity, geology, soil permeability, and structural type) to predict the potential indoor radon of a house [Gundersen et al. 1993].

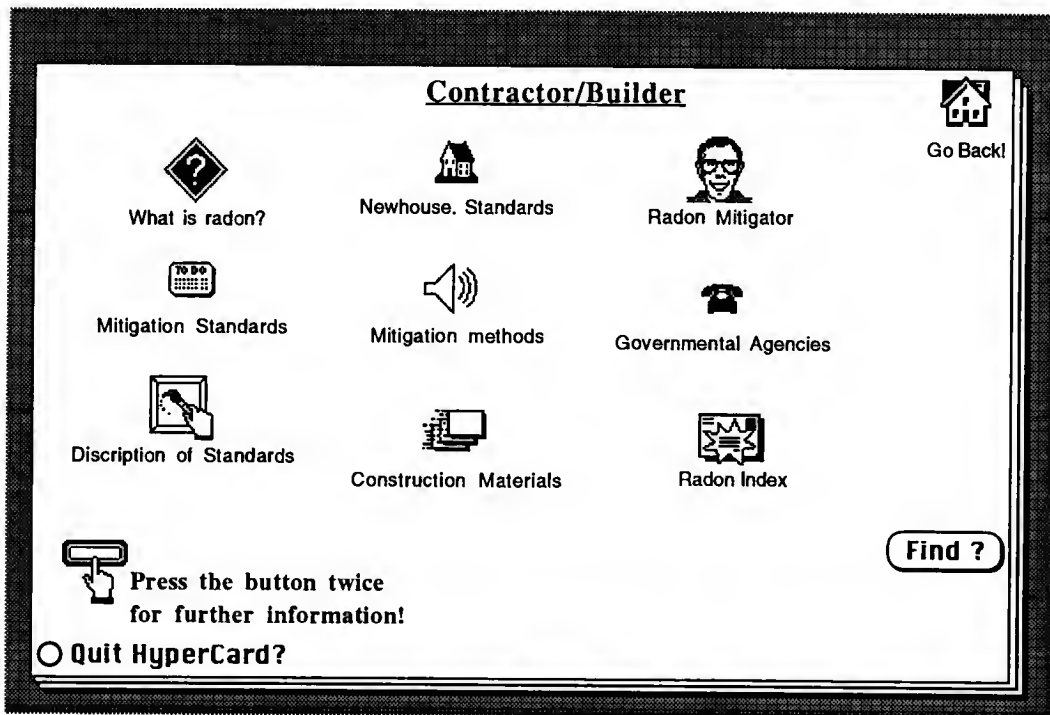

Figure 6.10 Contractor Database

Radon index is determined by the total score of the five parameters. Each parameter is assigned a certain point value depending on the characteristics of the house. The assigned score is listed in Table 6.1 [Gundersen et al. 1993]. The probable average indoor radon (radon index) is shown in Table 6.2. For example, average area indoor radon, aerial radioactivity, geology, soil permeability, foundation and wall type for a new house are 3.3 pCi/L, 1.5 ppm, positive, 1.0E-9, slab-on-grade, monolithic, respectively. The potential indoor radon level is between 2 to 4 pCi/L. The output of the program is illustrated in Figure 6.11.

Mitigation Methods Construction of mitigation methods (suction pit and Enkavent mat methods) are presented in both text and picture formats. Figure 6.12 illustrates the functions of mitigation methods database. One of the major radon entry points is through cracks in a floor slab. Selection of crack treatments and radon resistant slab drawings are linked to the MacSmarts expert system. MacSmarts performs the complicated alternatives selection advising.

### Researcher Database

This database provides information from on-going research projects, research related journals, and up-to-date radon research. The key elements of researcher database is presented in Figure 6.13. Key features are described as follows:



Table 6.1 Radon Index Matrix

Factor	Point	Value	
	1 point	2 points	3 points
Average indoor radon	<2 pCi/L (74 Bq/m <sup>3</sup> )	2-4 pCi/L (74-148 Bq/m <sup>3</sup> )	>4 pCi/L (148 Bq/m <sup>3</sup> )
Aerial radio-activity	<1.5 ppm eU	1.5-2.5 ppm eU	>2.5 ppm eU
Geology	negative	variable	positive
Soil permeability	<2.0 x 10 <sup>-10</sup>	2.0 x 10 <sup>-10</sup> to 2.0 x 10 <sup>-8</sup>	>2.0 x 10 <sup>-8</sup>
Structure type (a, b & c)			
a. foundation	Crawl space	Slab-on-grade	
b. wall	Monolithic	Stem wall	
c. slab	Fixed-end	Floating	

Modified from Gundersen et al. [1993]

Table 6.2 Probable Indoor Radon Level

Radon potential category	Point range	Probable average indoor radon
Low	<10	<2 pCi/L (74 Bq/m <sup>3</sup> )
Moderate	11 - 13	2 - 4 pCi/L (74-148 Bq/m <sup>3</sup> )
High	> 13	> 4 pCi/L (148 Bq/m <sup>3</sup> )



Modified from Gundersen et al. [1993]

  
User-index (Click me)

  
Go Back!

Radon Potential Index	
* Total point	13
** Radon potential category	Moderate/Variable
*** Probable average screening indoor radon for the house	Between 2 to 4 pCi/L

  
See Criteria Table



Figure 6.11 Program Output of Radon Index

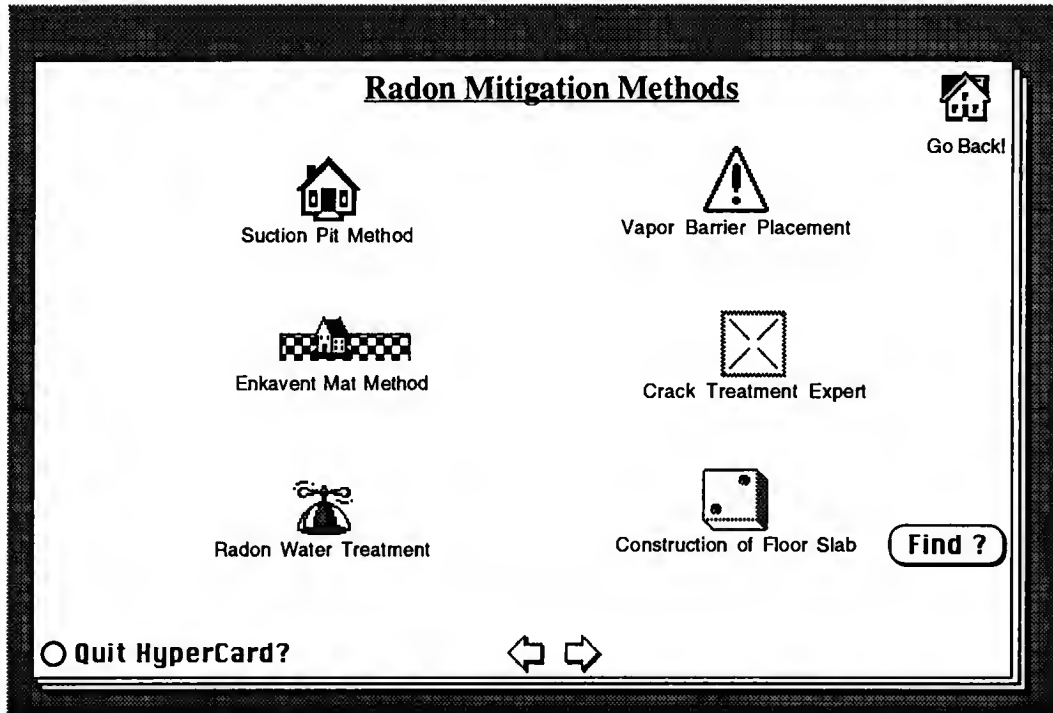

Figure 6.12 Functions of Mitigation Methods Database

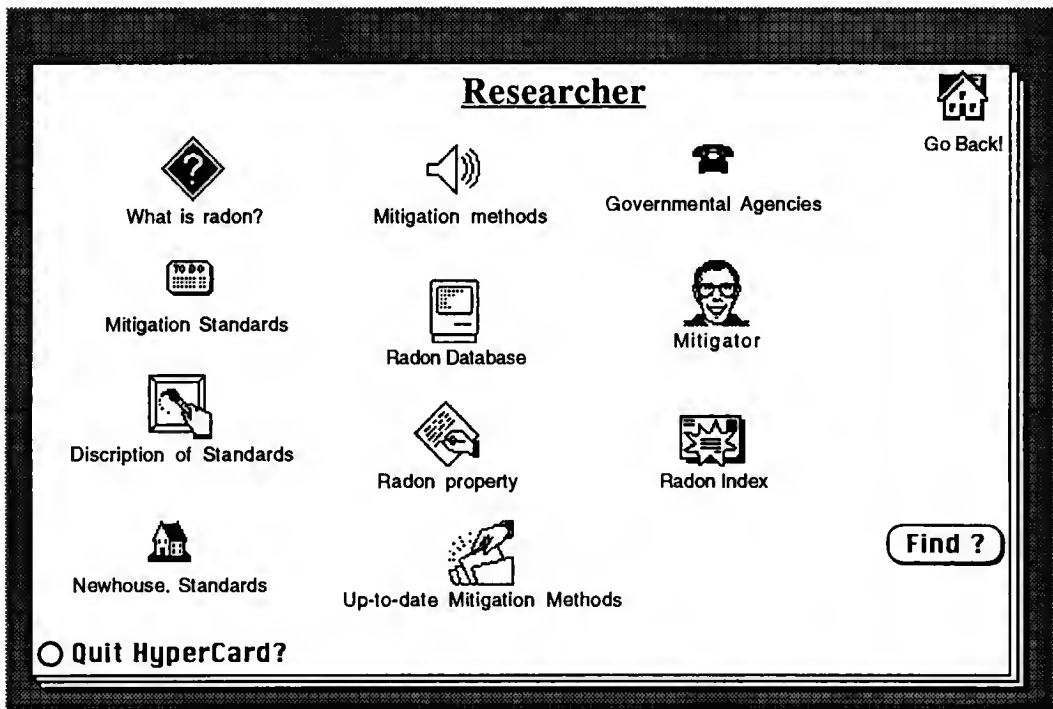

Figure 6.13 Key Elements of Researcher Database

Radon Theory Radon decay chains, indoor radon equations, soil permeability, soil moisture content, diffusion theory, and other topics are all detailed in this file.

Radon Research Update Based on the "Research up-date" of the EPA's quarterly publications, research progresses and on-going projects are summarized in this file. In addition, historical radon mitigation movements of the governmental agencies are listed in tables.

Radon mitigation methods This file contains the most up-to-date mitigation methods. The methods were applied in the past projects or are still in research.

#### Sample Applications of the Expert System

As previously mentioned, an expert system serves as one of the modules in the RIS. The expert system is active only when the system calls it. The expert system is applied in diagnosing crack problems, crack sealant selection, crack treatments, crack installation detail, and indoor radon prediction.

The expert system serves as a sub-module, and it is triggered by the Hypercard functional buttons. Connection from Hypercard to the MacSmarts expert system is shown in Figure 6.14. The MacSmarts expert system provides rule-based and sample-based knowledge bases. A rule-based knowledge base is created as regular rule programming. If the problem itself is structured and has a solid outcome, a

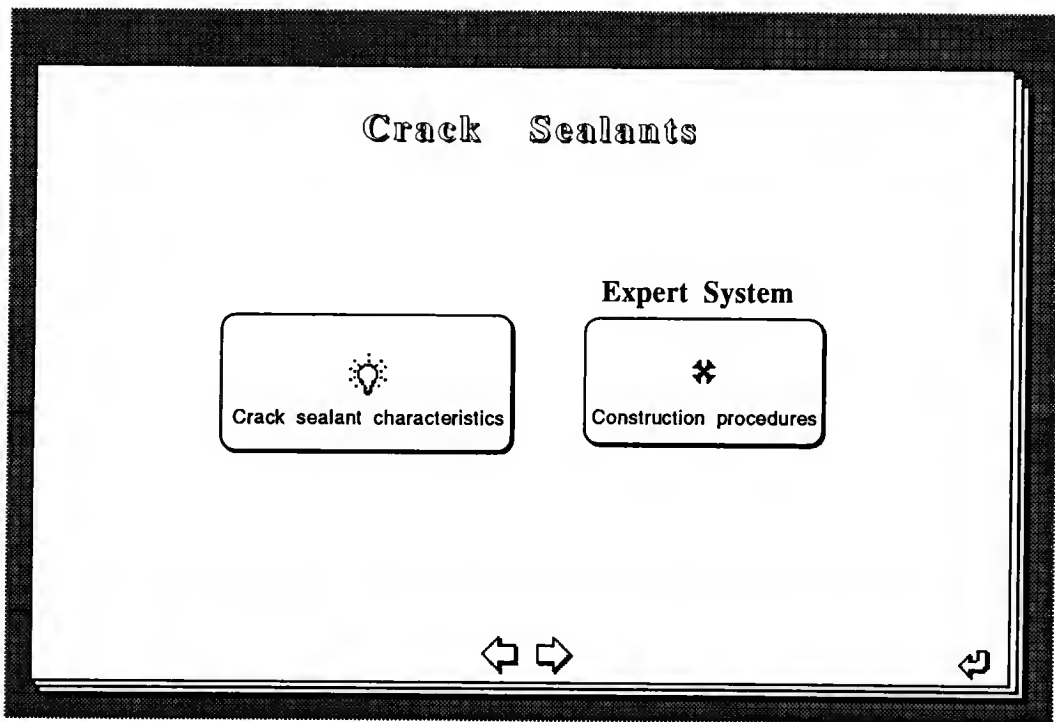

Figure 6.14 Linkage of Hypercard and MacSmarts Expert System

sample-based knowledge base can be established. A sample-based knowledge base turns factors and advice into examples. For example, indoor radon prediction depends on soil permeability and soil radon. A sample-based knowledge base encapsulates the facts and advice into examples.

The rule-based knowledge base is illustrated by crack sealant and crack diagnosis knowledge bases.

## A) MacSMARTS Rule-based Knowledge Base: crack.sealant

According to crack length and crack width, a crack sealant is advised for crack treatment by the MacSmarts expert system. The rules and advice of crack.sealant knowledge base are shown as follows:

## RULES:

- 1        No need to seal cracks.  
IF NO: Is the total crack length >15 feet?
- 2        Elastomeric coating  
IF YES: crack\_width<=stand\_crack
- 3        Sealant with backer rod.  
IF YES: Was saw cut applied?  
IF YES: crack\_width>stand\_crack
- 4        Elastomeric Membrane  
IF YES: crack\_width>stand\_crack

## ADVICE:

- 1        No need to seal cracks.
- 2        Elastomeric coating  
PRIMARY LINK:crack.fig.1a
- 3        Sealant with backer rod.  
PRIMARY LINK:crack.fig.1b
- 4        Elastomeric Membrane  
PRIMARY LINK:crack.fig.1c

A possible outcome of the crack treatments is illustrated in Figure 6.15.

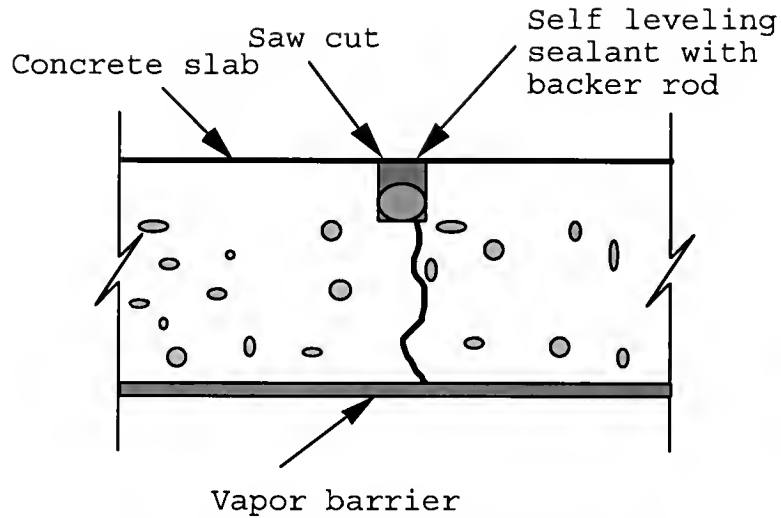

Figure 6.15 Expert System Output (crack.fig.1b) for Crack Treatments

B) MacSMARTS Rule-based Knowledge Base:crack.diagnosis.user

Crack formation depends on curing time, construction joints installation, construction joint spacing, temperature on site and construction quality. This knowledge base predicts the possible cracking based on these factors.

RULES:

1 The predicted concrete floor has : "Minor Cracking"

IF YES: period >= st.time

IF YES: Were construction joints installed?

PRIMARY LINK: summit-oaks.pict

IF YES: joint\_spacing <= joints

- 2       The predicted concrete floor has:"Moderate Cracking"
- IF NO: period>=st.time
- IF YES: Were construction joints installed?
- PRIMARY LINK:summit-oaks.pict
- IF YES: joint\_spacing<=joints
- 3       The predicted concrete floor has:"Moderate Cracking"
- IF NO: period>=st.time
- IF YES: Were construction joints installed?
- PRIMARY LINK:summit-oaks.pict
- IF NO: joint\_spacing<=joints
- IF YES: Temperature<=St.temp
- 4       The predicted concrete floor has:"Moderate Cracking"
- IF YES: period>=st.time
- IF NO: Were construction joints installed?
- PRIMARY LINK:summit-oaks.pict
- 5       The predicted concrete floor has:"Serious Cracking"
- IF NO: period>=st.time
- IF YES: Were construction joints installed?
- PRIMARY LINK:summit-oaks.pict
- IF NO: joint\_spacing<=joints
- IF NO: Temperature<=St.temp
- 6       The predicted concrete floor has:"Moderate Cracking"
- IF NO: period>=st.time



IF NO: Were construction joints installed?

PRIMARY LINK:summit-oaks.pict

IF YES: Temperature<=St.temp

IF YES: Was the concrete pouring in good quality?

7 The predicted concrete floor has : "Serious Cracking"

IF NO: period>=st.time

IF YES: Were construction joints installed?

PRIMARY LINK:summit-oaks.pict

IF NO: joint\_spacing<=joints

IF YES: Temperature<=St.temp

IF NO: Was the concrete pouring in good standard?

8 The predicted concrete floor has: "Serious Cracking"

IF NO: period>=st.time

IF NO: Were construction joints installed?

IF NO: Temperature>=St.temp

IF NO: Was the concrete pouring in good quality?

9 The predicted concrete floor has: "Moderate Cracking"

IF NO: period>=st.time

IF NO: Were construction joints installed?

PRIMARY LINK:summit-oaks.pict

IF NO: Temperature<=St.temp

IF YES: Was the concrete pouring in good quality?

10 The predicted concrete floor has : "Serious Cracking"

IF NO: period>=st.time

IF YES: Were construction joints installed?

IF NO: joint\_spacing<=joints

IF NO: Temperature<=St.temp

ADVICE:

- 1 The predicted concrete floor has : "Minor Cracking"
- 2 The predicted concrete floor has: "Moderate Cracking"
- 3 The predicted concrete floor has: "Moderate Cracking"
- 4 The predicted concrete floor has: "Moderate Cracking"
- 5 The predicted concrete floor has: "Serious Cracking"
- 6 The predicted concrete floor has: "Moderate Cracking"
- 7 The predicted concrete floor has: "Serious Cracking"
- 8 The predicted concrete floor has: "Serious Cracking"
- 9 The predicted concrete floor has: "Moderate Cracking"
- 10 The predicted concrete floor has: "Serious Cracking"

C) MacSMARTS Sample-based Knowledge Base: Indoor.Radon.predif

The indoor radon prediction knowledge base is an example of a sample-based knowledge base. Since the knowledge base is established in sample type, the rules are not shown in the knowledge base. The rules are simplified into factors, advice and samples. Users can use these factors and turn the facts into sample knowledge base. A sample-based knowledge base is illustrated as follows:

Factors: Soil permeability and Soil radon.

Choices:

- 1) Soil permeability (in/hr): <0.5, 0.5-1.0, 1.0-5.0, >5.0
- 2) Soil radon (pCi/L): 1000, 2000, 3300, 4000.

Advice: High, Medium or Low radon concentration.

Based on the values of the soil permeability and soil radon (factors), the model predicts the potential indoor radon level (advice). The decision table (sample base) is illustrated in Table 6.3 [Mose et al. 1992]. The prediction of the potential indoor levels is transformed into "Indoor.Radon.predif" knowledge base.

RULES:

1 Indoor radon (sample-based knowledge base)

ADVICE:

1 Indoor radon

PRIMARY LINK:indoor.prediction.pict

### System Testing and Validation

The system was tested and modified many times by many homeowners, potential new house buyers, and researchers. Their suggestions were incorporated in the system. The radon research teams of UF provided many excellent recommendations which make this program more useful.

The indoor radon prediction program was tested for its precision. In one tested case, the predicted indoor radon level was between 2 to 4 pCi/L, and the actual measured indoor radon level was 2.3 pCi/L. Some tests showed accurate prediction, but some predicted a little bit higher. However, only limited data sets were available because the uranium concentrations were not available in most of the

houses. A reasonable value was assumed. For example, the uranium content in Alachua county was assumed to be the average 1.5 ppm. RIS provides mostly recommended information. It is a reference to the user. The author suggests that the user should have her/his house tested for indoor radon level even the user consulted with the indoor radon prediction program.

RIS demonstrates the flexibility of retrieving information and resolving possible radon problems, selecting radon mitigation methods, crack prevention methods, predicting potential radon levels, and providing useful radon information. This user-friendly system is effective and applicable.

#### Summary

The RIS has demonstrated a successful knowledge-presenting and information-retrieving computer-aided program. Construction of a radon resistant building can be obtained from this system effectively and precisely. This system also provides diagnosis and prediction of indoor radon levels. The radon knowledge bases presented in this system provide homeowner, contractor, and researcher with a friendly environment in which to search for information.

The information provided by RIS is updated to cover the state-of-the-art radon mitigation methods and research progress. In addition, radon knowledge stored and organized in RIS could also be helpful for future research.

Table 6.3 Decision Table of the Indoor Radon Prediction

	Soil Permeability	Soil Radon (pCi/L)	Predicted Indoor Radon (pCi/L)
1	0.5 < SP ≤ 1.0	SR ≤ 1000	Low (0~5)
2	1.0 < SP ≤ 5.0	SR ≤ 1000	Low (0~5)
3	5.0 < SP	SR ≤ 1000	Low (0~5)
4	SP ≤ 0.5	SR ≤ 1000	Low (0~5)
5	SP ≤ 0.5	1000 < SR ≤ 2000	Low (0~5)
6	0.5 < SP ≤ 1.0	1000 < SR ≤ 2000	Medium (5 ~ 15)
7	1.0 < SP ≤ 5.0	1000 < SR ≤ 2000	Medium (5 ~ 15)
8	5.0 < SP	1000 < SR ≤ 2000	Medium (5 ~ 15)
9	SP ≤ 0.5	2000 < SR ≤ 3300	Medium (5 ~ 15)
10	0.5 < SP ≤ 1.0	2000 < SR ≤ 3300	Medium (5 ~ 15)
11	1.0 < SP ≤ 5.0	2000 < SR ≤ 3300	High (15 or above)
12	5.0 < SP	2000 < SR ≤ 3300	High (15 or above)
13	SP ≤ 0.5	3300 < SR	High (15 or above)
14	0.5 < SP ≤ 1.0	3300 < SR	High (15 or above)
15	1.0 < SP ≤ 5.0	3300 < SR	High (15 or above)
16	5.0 < SP	3300 < SR	High (15 or above)

Modified from Mose et al. [1992]

CHAPTER 7  
CONCLUSIONS AND RECOMMENDATIONS

Summary and Conclusion

Radon problems were investigated from substructure to superstructure. The causes of radon, radon sources, radon entry mechanisms, crack study, the research results of UF and mitigation methods were detailed in this research. A computer aided program, Radon Information System, was developed based on these findings.

Effectiveness of the Radon Mitigation Methods

Radon concentration is affected by many factors and these are usually inter-related. Through the research projects of UF, no one significant factor was found that directly influences radon intrusion. However, the research results show that it is satisfactory to reduce radon entry. The mitigation methods employed by UF have effectively reduced indoor radon to an acceptable level. The average indoor radon levels of projects in 1992 and 1993 are 2.49 and 2.76 pCi/L, respectively. These levels are less than

the EPA standard, 4 pCi/L.

Regardless of the inconclusiveness of house ventilation and pressure differential tests, the passive barrier is successful in constructing a radon resistant house. Furthermore, the mitigation methods are commercially feasible.

#### Cost-Effectiveness of the Mitigation Systems

The cost of installing a mitigation system is around \$500 to \$1000 for a single-family three-bedroom house. In comparing this amount to the cost of a new house, it is relatively small. It is feasible to spend around \$1000 to have a safe living environment.

#### Advantages of Radon Information System

Information for constructing a radon resistant building can be obtained from this system effectively and precisely. This system also provides diagnosis of cracks and prediction of potential indoor radon levels. The radon knowledge bases presented in this system provide the homeowner, contractor, and researcher with a animated environment in which to search for information.

The information provided by RIS is updated to cover the

state-of-the-art radon mitigation methods and research progress. Radon knowledge stored and organized in RIS could also be helpful in future research.

### Recommendations

The graphical presentation of the Hypercard is limited. If the memory can be enlarged, a larger scale picture can be shown. In addition, the execution speed should be improved. It takes much longer to open a file than to open an IBM PC or a comparable one. Likewise, the ability to access spreadsheets is restricted. A more flexible program should be incorporated.

Because of time and financial limitations now, the proposed mitigation system must continue to be researched. Also, more expert experience should be obtained through research and governmental agencies.

Perforated pipe method may be implemented in future research, because its coverage is large than the suction pit method and its costs are less than the Enkavent mat method.

Finally, since radon measurement precision was affected by tube length as discussed in Chapter 4, the EPA should consider this issue in the future radon measurements.



Author's Contribution to the Advancement of Radon Knowledge

The crack study analyzed the potential radon entry through concrete slabs. It was found that new houses have better crack resistance than old houses. Construction joints can reduce crack growth. Ample curing time and proper curing methods must be used to reduce cracking.

The indoor radon prediction model is a newly developed tool which is based on previous work and incorporates the new findings of this study. This model provides an effective estimate of the radon level of a new house.

The author has also developed the Radon Information System, which has demonstrated to be a useful knowledge-presenting and information-retrieving computer-aided program. The radon knowledge stored in this system can be used to assist users effectively.

APPENDIX A  
STATISTICS PROGRAMS

This file demonstrates some input and out data by SAS programs. The data are from the UF project results. There is a brief explanation of each program.

Testing Equality of Four ACH Experiments

This program is for testing the equality of house ventilation under four different conditions. The input data and testing methods (Tukey's comparison, Ttest) are presented. An output of the program was shown in Table 4.9.

```
C ***** Four ACH Tests ***** C
C NHEP-92, Updated on: 5/18/94 C
C File: C:\radon\nhep\ach92_4t.sas C
C Comparison of 4 tests of ACH C
C Test 1: Natural Ventilation C
C Test 2: Air Handler on C
C Test 3: Air Handler on doors Closed C
C Test 4: SSD Exhaust fan on C
```

```
options ps=62 ls=74;
data one;
do radon=1 to 20;
do test=1 to 4;
input ach@@;
output;
end;
end;
cards;
0.144      0.327      0.626      0.169
0.495      0.424      0.557      0.159
```

0.215	0.317	0.631	0.188
0.278	0.352	0.743	0.111
0.190	0.419	0.687	0.372
0.203	0.412	0.437	0.174
0.121	0.518	0.786	0.247
0.331	0.553	0.735	0.223
0.208	0.3	0.764	0.145
0.316	0.928	0.916	0.294
0.179	0.407	0.763	0.141
0.545	0.553	N/A	0.465
0.2	0.404	0.811	0.213
0.192	0.335	0.493	0.23

;

```

proc means;
var ach;
title ' ';
run;
data two;
set one;
proc plot;
plot ach*test;
run;
data three;
set one;
proc chart;
vbar ach/ sumvar=ach group=test midpoints=0.5 ;
run;

```

C \*\*\*\*\* Tukey's Comparison of multiple means \*\*\*\*\*

```

proc glm;
class test;
model ach=test;
means test/ tukey;
run;

data four;
set one;
if test=1 or test=2;
run;

data five;
set one;
if test=1 or test=3;
run;

```

```
data six;
set one;
if test=1 or test=4;
run;
```

```
data sev;
set one;
if test=2 or test=3;
run;
```

```
data eig;
set one;
if test=2 or test=4;
run;
```

```
data nin;
set one;
if test=3 or test=4;
run;
```

```
C ***** Test for the means of two variables *****
```

```
proc ttest data=four;
class test;
var ach;
title' Test 1&2';
run;
```

```
proc ttest data=five;
class test;
var ach;
title'Test 1 & 3';
run;
```

```
proc ttest data=six;
class test;
var ach;
title'Test 1 & 4';
run;
```

```
proc ttest data=sev;
class test;
var ach;
title'Test 2 & 3';
run;
```

```
proc ttest data=eig;
class test;
var ach;
title'Test 2 & 4';
run;
```

```
proc ttest data=nin;
class test;
var ach;
title'Test 3 & 4';
run;
```

### Indoor Radon and Its correlation tests

This program is for calculating the correlation between two parameters. The input data, normality tests and some program output are presented.

C \*\*\*\*\* Correlation Between Parameters \*\*\*\*\* C

C NHEP-93, Updated on: 5/18/94 C

```
options ps=62 ls=74;
data one;
input house $ soilrd cracklg crackrd subrd indoord infil;
cards;
```

Resver-4	1683	0	0	n	2.07	0.49
Resver-8	2896	0	0	n	2.52	0.31
Resver-48	2935	24	180	638	2.99	0.33
Resver-39	1189	132	227	424	2.24	0.34
Resver-30	911	0	0	n	2.7	0.27
HaysGlen	3822	N1668	3	550	n	n
SummitOaks	1112	108	48.2	2934	4.16	0.26
RobinLane	6607	312	6.78	306	2.72	0.38
Kenwood	1055	0	0	n	2.86	0.21
TurkeyCreek	1298	120	10	2573	n	n
IndianPine	N32988	0	0	n	2.6	n
FletcherMill	3485	0	0	n	n	n

C Note: Extreme data were taken out: N32988 & N1668

```
;
```

```
proc print;
```

```
proc means;
run;
C *** Testing the Normality of data sets ***
proc univariate freq plot normal;
var soilrd cracklg crackrd subrd indoord infil;
run;

C *** Calculation of correlation ***
proc corr;
var soilrd cracklg crackrd subrd indoord infil;
run;

proc plot;
plot cracklg*crackrd;
proc corr;
var cracklg crackrd;
run;

proc plot;
plot soilrd*subrd;
proc corr;
var soilrd subrd;
run;

proc plot;
plot soilrd*indoord;
run;

proc plot;
plot indoord*infil;
run;

data two;
set one;
soilcrlg=soilrd*cracklg;
proc plot;
plot soilcrlg*indoord;
proc corr;
var soilcrlg indoord;
run;
```

#### Sample Program output: Normality

This output shows the normality of the data.

## UNIVARIATE PROCEDURE

Variable=SOILRD

## Moments

N	9	Sum Wgts	9
Mean	2731.444	Sum	24583
Std Dev	1818.257	Variance	3306057
Skewness	1.186567	Kurtosis	1.630884
USS	93595555	CSS	26448456
CV	66.56758	Std Mean	606.0855
T:Mean=0	4.506698	Prob> T	0.0020
Sgn Rank	22.5	Prob> S	0.0039
Num ^= 0	9		
W:Normal	0.88004	Prob<W	0.1546

## Quantiles(Def=5)

100% Max	6607	99%	6607
75% Q3	3485	95%	6607
50% Med	2896	90%	6607
25% Q1	1189	10%	911
0% Min	911	5%	911
		1%	911
Range	5696		
Q3-Q1	2296		
Mode	911		

## Extremes

Lowest	Obs	Highest	Obs
911(	5)	2896(	2)
1055(	9)	2935(	3)
1189(	4)	3485(	12)
1683(	1)	3822(	6)
2896(	2)	6607(	8)

## Missing Value

Count	3
% Count/Nobs	25.00

The normality for soil radon is 0.88004 which is high.  
Therefore, assume that the data are normal.

Sample Program Output: Correlation

## CORRELATION ANALYSIS

6 'VAR' Variables:SOILRD CRACKLG CRACKRD SUBRD INDOORD  
INFIL

## Simple Statistics

Variable	N	Mean	Std Dev	Sum	Minimum	Maximum
SOILRD	11	2454	1740	26993	911.0000	6607
CRACKLG	11	63.2727	98.6763	696.0000	0	312.0000
CRACKRD	12	39.5817	78.3968	474.9800	0	227.0000
SUBRD	6	1237	1185	7425	306.0000	2934
INDOORD	9	2.7622	0.5977	24.8600	2.0700	4.1600
INFIL	8	0.3237	0.0855	2.5900	0.2100	0.4900

Pearson Correlation Coefficients / Prob > |R| under Ho:  
Rho=0 / Number of Observations

	SOILRD	CRACKLG	CRACKRD	SUBRD	INDOORD	INFIL
SOILRD	1.00000	0.58771	-0.17310	-0.61733	-0.10181	0.35617
	0.0	0.0740	0.6108	0.1916	0.8104	0.3865
	11	10	11	6	8	8
CRACKLG	0.58771	1.00000	0.16126	-0.30703	0.14643	0.19586
	0.0740	0.0	0.6357	0.6153	0.7070	0.6420
	10	11	11	5	9	8
CRACKRD	-0.17310	0.16126	1.00000	-0.35150	-0.02473	.03842
	0.6108	0.6357	0.0	0.4945	0.9496	0.9280
	11	11	12	6	9	8
SUBRD	-0.61733	-0.30703	-0.35150	1.00000	0.94048	-0.93790
	0.1916	0.6153	0.4945	0.0	0.0595	0.0621
	6	5	6	6	4	4
INDOORD	-0.10181	0.14643	-0.02473	0.94048	1.00000	-0.57316
	0.8104	0.7070	0.9496	0.0595	0.0	0.1375
	8	9	9	4	9	8
INFIL	0.35617	0.19586	0.03842	-0.93790	-0.57316	1.00000
	0.3865	0.6420	0.9280	0.0621	0.1375	0.0
	8	8	8	4	8	8



APPENDIX B  
HYPERTALK PROGRAMS

HyperTalk Scripts

The Hypercard programming language, HyperTalk is the main control mechanism in between stacks, cards, fields and buttons. The HyperTalk programs are called "scripts". Some of the main scripts of the databases are listed as follows.

Some useful programs of the RIS are presented. The programs illustrate the functions of connection, special effects, and data transferring of the Hypercard. A brief explanation of the functions is supplied in the programs.

Stack Scripts--Main Menu

```
on openstack--instructions
repeat 3
put "Please select appropriate button for further
information!" into card field"sele"
wait 2 second
put empty into card field "sele"
end repeat
end openstack
on openStack
```

```
hide message box
show menuBar
pass openStack
end openStack
```

### Card Scripts

```
on opencard-- Card first
play "harpsichord" "ge ge aq gq e5q b4h ge ge aq gq d5q ch
g4e ge g5q ce ce b4q aq f5e fe eq cq dq ch"--sound
end opencard
on opencard-- Card goo
-- selection of corresponding database from user
  get first line of card field "open"
  if it is "1" then
    go to stack"home.owner"
  else if it is "2" then
    go to stack"contractor-builder"
  else go to stack"researcher"
end opencard
```

### Stack--Homeowner

```
Button Scripts -- First Card
on mouseUp-- what to do
  go to stack"what.to.do"
end mouseUp
on mouseUp-- what is radon?
  go to card "whatis" of stack "what.is.radon.own"
```

```

end mouseUp
on mouseUp-- EPA standard
    visual dissolve
    go to stack"EPA.standard.own"
end mouseUp
on mouseUp-- Mitigator
    visual effect iris open
    go to stack "radon.mitigator.own"
end mouseUp
on mouseUp-- Newhouse Standards
    -- visual effect checkerboard
    -- visual effect iris open
    --visual effect scroll right
    flash 3
    visual stretch from top
    visual effect wipe left very slow to inverse
    go to stack"Newhouse.home"
end mouseUp
on mouseUp-- State Radon
    dial "904-336-8214"
    go to stack"state.radon.own"
end mouseUp
on mouseUp-- Quit HyperCard
    answer "Are you sure that you want to quit?" with "Yes" or
    "No"
    if it is "yes" then
        --domenu"compact stack"

```

```

visual dissolve to inverse
domenu"Quit HyperCard"
end if
end mouseUp

```

### Stack-- EPA Standards

```

on opencard-- Card epa
  repeat 5
    put "EPA STANDARDS" into card field epa1
    wait 40
    put empty into card field epa1
  end repeat
  put "EPA STANDARDS" into card field epa1
end opencard

on opencard-- Card other
  -- play "boing" tempo 120 "ge ge aq gq e5q b4h ge ge aq
  gq d5q ch g4e ge g5q ce ce b4q aq f5e fe eq cq dq ch"
  repeat 5
    put "OTHER RADON STANDARDS" into card field OTHER
    wait 40
    put empty into card field OTHER
  end repeat
  put "OTHER RADON STANDARDS" into card field OTHER
end opencard

```

### Stack-- Newhouse\_standards

```

on openstack

```

```
visual effect dissolve to white
wait 1 seconds
repeat 5
    put "Hi! Look!" into card field"look1"
    wait 20
    put empty into card field "look1"
end repeat
put "Hi! Look!" into card field"look1"
wait 30 seconds
flash 2
visual effect wipe right very slowly
go to card id 6123
repeat 5
    put "Hi! Look!" into card field"look1"
    wait 20
    put empty into card field "look1"
end repeat
put "Hi! Look!" into card field"look1"
wait 25 seconds
visual effect iris close
go to card id 5572
Repeat 5
wait 60
put"Press the button twice for further information!" into
    card field pr1
wait 40
visual dissolve to white
```

```

visual effect wipe up slowly
visual effect iris close very slowly
put empty into card field pr1
end repeat
put "Press the button twice for further information!" into
    card field pr1
end openstack

```

### Stack-- Newhouse.Title

```

on openstack
  repeat 12
    lock screen
    go to next card
    unlock screen
  end repeat
  go to card id 5361 of stack "newhouse"
end openstack

```

### Stack-- Stack Radon

```

on mouseUp-- Stack Radon Contacts
  --on openstack
  set lockmessages to true
  ask "Which state are you interested in?"
  -- if it is empty then exit mouseup
  if it is empty then answer "No state was selected!"
  else put it into findstring
  lock screen

```

```

set cursor to busy
-- repeat forever
find whole findstring
if the foundline is empty
then answer "No state was found!"
if the foundline is empty
then exit mouseup
end mouseUp

```

### Stack-- Mitigation Methods

```

on opencard-- first
  set hilite of card button "quit hypercard?" to false
  end opencard
on openstack--change text size
  set textsize of card field"mi" to 14
  wait 10
  set textsize of card field"mi" to 12
  wait 10
  set textsize of card field "mi" to 14
  wait 10
  set textsize of card field "mi" to 16
end openstack

```

```

on mouseUp-- Suction pit
  visual dissolve to white
  visual effect venetian blinds slow
  -- visual effect iris close very slowly

```

```
play "boing" twice
show card field "note"
wait 5 seconds
hide card field "note"
go card "detail"
end mouseUp
```

```
on opencard-- ins
  picture "pit1",file,dialog
  wait 100
  beep 2
  answer "You may use scrolling bar for more information!"
with "OK" or "Cancel"
  if it is "OK" then
    repeat 4
      put "Use mouse to drag the window!" into card field
      b22
      wait 60
      put empty into card field b22
    end repeat
  else
    repeat 4
      put "Select next card!" into card field b22
      wait 60
      put empty into card field b22
    end repeat
  end if
```



```

--put "Go next card for a clearer but smaller scale
picture!" into msg
-- show msg
-- wait 5 seconds
-- hide msg
end opencard
on closecard
  close window"pit1"
end closecard

```

```

On opencard-- cost
  visual dissolve to black
  wait 3 seconds
  set numberformat to "0"
  put 3048/1300 into third line of card field"pits"
  answer"Do you want to have the cost estimation for a
particular floor area? " with "yes" or "No"
  if it is "yes" then go next card
  end opencard
on mouseleave-- field co2
  global mtot
  global ltot
  put 0 into mtot
  put 0 into ltot
  set lockmessages to true
  set numberformat to "0"
  repeat with j=2 to 8

```

```

    get line j of card field "co2"
    add it to mtot
    get line j of card field "co3"
    add it to ltot
end repeat
put mtot into line 9 of card field "co2"
put ltot into line 9 of card field "co3"
get line 9 of card field "co2"+ line 9 of card field "co3"
put it into line 10 of card field "co2"
repeat with j=1 to number of lines of card field"co2"
    get line j of card field"co2"
    put it into line j of card field"coo2" of card "cost2"
end repeat
set lockmessages to false
end mouseleave
on mouseleave-- field co3
global mtot
global ltot
put 0 into mtot--initialization
put 0 into ltot--initialization
set lockmessages to true
set numberformat to "0"
repeat with j=2 to 8
    get line j of card field "co2"
    add it to mtot
    get line j of card field "co3"
    add it to ltot

```

```

end repeat
put mtot into line 9 of card field "co2"
put ltot into line 9 of card field "co3"
get line 9 of card field "co2"+ line 9 of card field "co3"
put it into line 10 of card field "co2"
repeat with j=1 to number of lines of card field"co3"
  get line j of card field"co3"
  put it into line j of card field"coo3" of card "cost2"
end repeat
set lockmessages to false
end mouseleave

```

#### stack-- crack

```

card-- crack information
on mouseUp-- crack diagnosis
  visual effect checkerboard fast
  open"crack.diagnosis.user"with "MacSMARTS™ Professional"
    -- link to MacSMARTS™ expert system
end mouseUp

```

#### card--crack.sealants

```

on mouseUp-- construction procedures
  open"crackseaff.user"with "MacSMARTS™ Professional"
end mouseUp

```

#### stack-- Radon Index

```

card-- county

```

```

on mouseUp-- index
  put 0 into pt1 --initialization
  put 0 into pt2
  put 0 into pt3
  put 0 into pt4
  put 0 into pt5
  put "There are Alachua, Baker and Bay counties available
    at this moment" into msg
  put empty into card field"findex2"
  set lockmessages to true
  ask "Which county are you interested in?"
  -- if it is empty then exit mouseup
  if it is empty then answer "No county was selected!"
  else put it into findstring
  lock screen
  set cursor to busy
  -- repeat forever
  find whole findstring
  if the foundline is empty
  then answer "No county was found!"
  if the foundline is empty
  then exit mouseup
  --answer "your selected county was" & findstring&
  put word 2 of the foundline into key1
  -- put key1 into msg
  put word 2 of line key1 of card field"data" into d1
  put word 3 of line key1 of card field"data" into d2

```

```
put word 4 of line key1 of card field"data" into d3
put word 5 of line key1 of card field"data" into d4
put word 6 of line key1 of card field"data" into d5
```

```
if d1<2 then put 1 into pt1
else if d1>=2 or d1<=4 then put 2 into pt1
else put 3 into pt1
if d2<1.5 then put 1 into pt2
else if d2>=1.5 or d2<=2.5 then put 2 into pt2
else put 3 into pt2
```

```
if d3=negative then put 1 into pt3
else if d3=variable then put 2 into pt3
else put 3 into pt3
```

```
if d4=low then put 1 into pt4
else if d3=moderate then put 2 into pt4
else put 3 into pt4
```

```
if d5=slab then put 1 into pt5
else if d3=mixed then put 2 into pt5
else put 3 into pt5
```

```
add pt1 to pt2
add pt2 to pt3
add pt3 to pt4
add pt4 to pt5
```

```

put pt5 into line 1 of card field "findex"
If pt5 >3 and pt5<=8 then put "LOW" into pot
else if pt5>8 and pt5<=11 then put "Moderate/Variable"
    into pot
else put "HIGH" into pot
put pot into line 2 of card field "findex"
If pt5 >3 and pt5<=8 then put "<2 pCi/L" into indoor
else if pt5>8 and pt5<=11 then put "2-4 pCi/L" into indoor
else put ">4 pCi/L" into indoor
put indoor into line 4 of card field "findex"

repeat with j=1 to number of lines of card field"findex"
get line j of card field"findex"
put it into line j of card field"findex2" of card "county"
end repeat
go back
unlock screen
hide msg
set lockmessages to false
-- if pt5 is 0
--then answer "No county was found!"
--show msg
end mouseUp

card--individual
-- Indoor Radon Prediction

```

```
on mouseUp-- User-index
  hide card field"findex"
  hide card field"tot"
  hide card button"po"
  put 0 into pt1
  put 0 into pt2
  put 0 into pt3
  put 0 into pt4
  put 0 into pt5
  put 0 into pt6
  put 0 into pt7
  put empty into d1
  put empty into d2
  put empty into card field"findex"
  set lockmessages to true --speed up

  repeat 3
    ask "What is the average INDOOR RADON (pCi/L) level in
your area?"
    if it is empty then answer "No INDOOR RADON level was
selected!"
    else put it into d1
    if d1 is not empty
      then exit repeat
  end repeat
  if d1 is empty
  then exit mouseup
```

```
repeat 3
  ask "What is the AERIAL RADIOACTIVITY (ppm eU) level in
your area?"
  if it is empty then answer "No AERIAL RADIOACTIVITY
level was selected!"
  else put it into d2
  if d2 is not empty
  then exit repeat
end repeat
if d2 is empty
then exit mouseup
show card field"rock"
answer "What is the GEOLOGY FORMATION in your area?" with
"NEGATIVE" or "VARIABLE" or "POSITIVE"
if it is empty then answer "No GEOLOGY FORMATION was
selected!"
else put it into d3
hide card field"rock"
show card field"perm"
answer "What is the SOIL PERMEABILITY in your area?" with
"P<2E-10" or "2E-10<p<8E-8" or "P>8E-8"
if it is empty then answer "No SOIL PERMEABILITY was
selected!"
else put it into d4
hide card field"perm"
```



answer "What is the FOUNDATION TYPE of the house?" with  
"SlabOnGrade" or "Crawl Space"

if it is empty then answer "No FOUNDATION TYPE was  
selected!"

else put it into d5

answer "What is the WALL TYPE of the house?" with  
"Monolithic" or "Stem wall"

if it is empty then answer "No WALL TYPE was selected!"

else put it into d6

if it is "stem wall" then

answer "What is the SLAB TYPE of the house?" with

"Floating" or "Fixed End"

else put 1 into d7

if it is empty then answer "No WALL TYPE was selected!"

else put it into d7

if  $d1 < 2$  then put 1 into pt1

else if  $d1 \geq 2$  or  $d1 \leq 4$  then put 2 into pt1

else put 3 into pt1

if  $d2 < 1.5$  then put 1 into pt2

else if  $d2 \geq 1.5$  or  $d2 \leq 2.5$  then put 2 into pt2

else put 3 into pt2

if  $d3 = \text{negative}$  then put 1 into pt3

else if  $d3 = \text{variable}$  then put 2 into pt3

else put 3 into pt3

if  $d4 = "P < 2E-10"$  then put 1 into pt4

```
    else if d3="2E-10<p<8E-8" then put 2 into pt4
    else put 3 into pt4
if d5=SlabOnGrade then put 2 into pt5
    else put 1 into pt5
if d6=Monolithic then put 1 into pt6
    else put 2 into pt6
if d7=Floating then put 2 into pt7
    else put 1 into pt7

add pt1 to pt2
add pt2 to pt3
add pt3 to pt4
add pt4 to pt5
add pt5 to pt6
add pt6 to pt7
put pt7 into line 1 of card field "findex"
If pt7<=10 then put "LOW" into pot
else if pt7>10 and pt7<=13 then put "Moderate/Variable"
    into pot
else put "HIGH" into pot
put pot into line 2 of card field "findex"
If pt7<=10 then put "Less than 2 pCi/L" into indoor
else if pt7>10 and pt7<=13 then put "Between 2 to 4 pCi/L"
into indoor
else put "Greater than 4 pCi/L" into indoor

put indoor into line 4 of card field "findex"
```

```
--show card field"data"  
show card field"tot"  
show card button"po"  
show card field"findex"  
set lockmessages to false  
end mouseUp
```

The following pages are the sample cards of the RIS.

### What is radon gas?

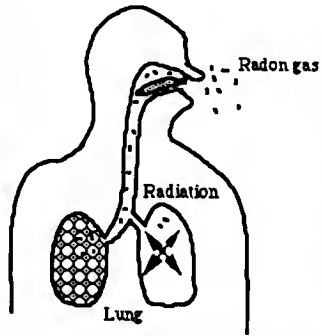

\* Radon (Rn-222) is the decay product of uranium. It is a radioactive, odorless, colorless, naturally occurring gas. It can contribute to significant damage to respiratory tissue under conditions of prolonged exposure to elevated concentrations of the gas. Constantly exposure to high concentration of radon gas will cause lung cancer.



### Common Radon Entry Points

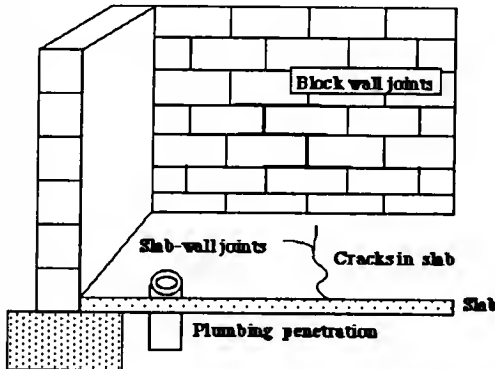

1. Slab-wall Joints
2. Cracks in slab
3. Plumbing penetrations
4. Block wall joints



### Radon Entry Paths

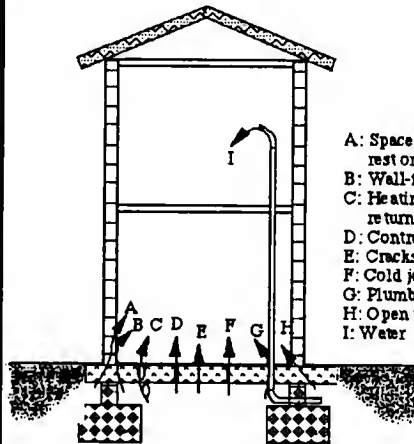

- A: Spaces behind brick veneer walls that rest on uncapped hollow-block foundation
- B: Wall-floor Joint
- C: Heating duct registers or subslab cold-air return pipes
- D: Control Joints or saw cuts
- E: Cracks in concrete slab
- F: Cold joints between two concrete pours
- G: Plumbing penetrations
- H: Open tops of block walls
- I: Water





**EPA STANDARDS**

  
Go Back!

**Indoor Radon Concentration**

1. Above 4 pCi/L:  
*Should install mitigation systems.*
2. Greater than 2 pCi/L but less than 4 pCi/L:  
*Consider fixing.*
3. Less than 2 pCi/L:  
*It is safe under current technology.*

 





  
Go Back!

  
User-index (Click me)

**Radon Potential Index**

* Total point	13
** Radon potential category	Moderate/Variable
*** Probable average screening indoor radon for area 	Between 2 to 4 pCi/L

  
See Criteria Table

 





**Crack Information**

  
 Causes of cracks

  
 Crack treatment



  
 Crack Sealants

  
 Crack Classification

  
 Crack Diagonosis

Find ?

○ Quit HyperCard?

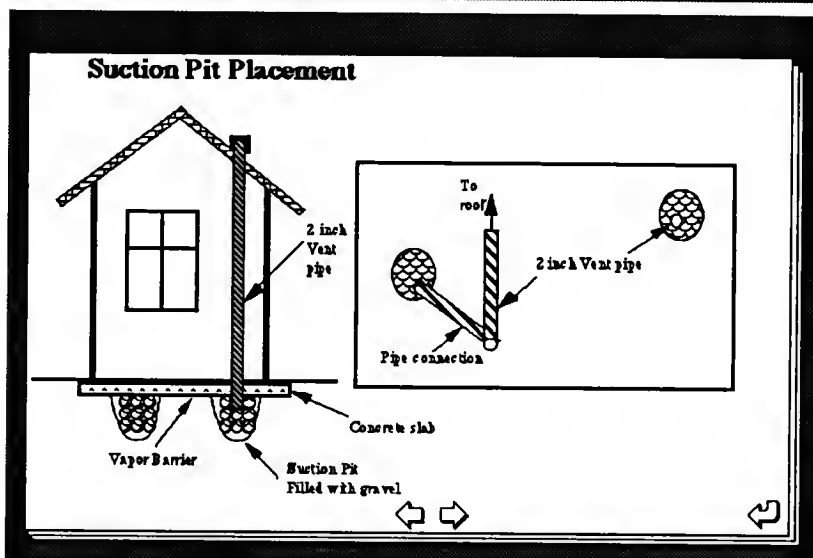
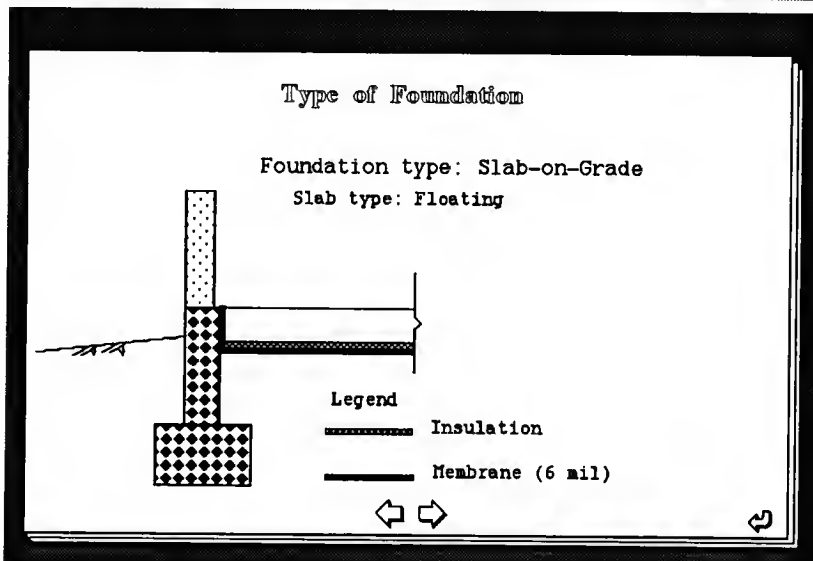
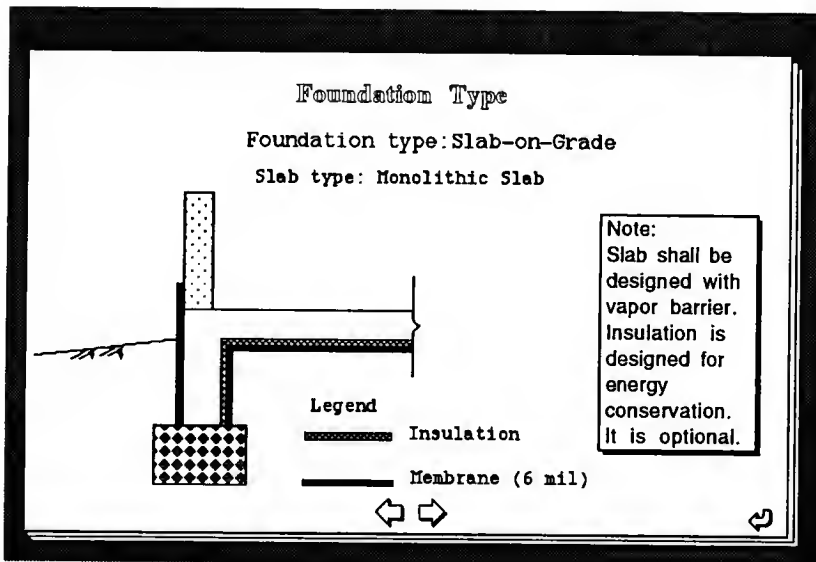

## APPENDIX C

### EXPERT SYSTEM KNOWLEDGE BASES

This file illustrates some knowledge bases of the RIS. The rules and advice of the knowledge bases are presented. Crack sealant, crack treatment, crack diagnosis, and sample-based indoor radon prediction knowledge bases are demonstrated.

#### Crack Sealant Knowledge Base

This file illustrates the selection of a crack sealant by total crack length and crack width.

MacSMARTS Knowledge Base: crackseaff

FACTS:

1 TRUE

RULES:

1 No need to seal cracks.

IF NO: Is the total crack length >15 feet?

2 Elastomeric coating

IF YES: crack\_width<=stand\_crack

3 Sealant with backer rod.

IF YES: Was saw cut applied?

IF YES: crack\_width>stand\_crack

4 Elastomeric Membrane

IF YES: crack\_width>stand\_crack

ADVICE:

1 No need to seal cracks.

2 Elastomeric coating

PRIMARY LINK:crack.fig.1a

3 Sealant with backer rod.

PRIMARY LINK:crack.fig.1b

4 Elastomeric Membrane

PRIMARY LINK:crack.fig.1c

Primary links are the suggestions of the knowledge base.

Crack.fig.1a

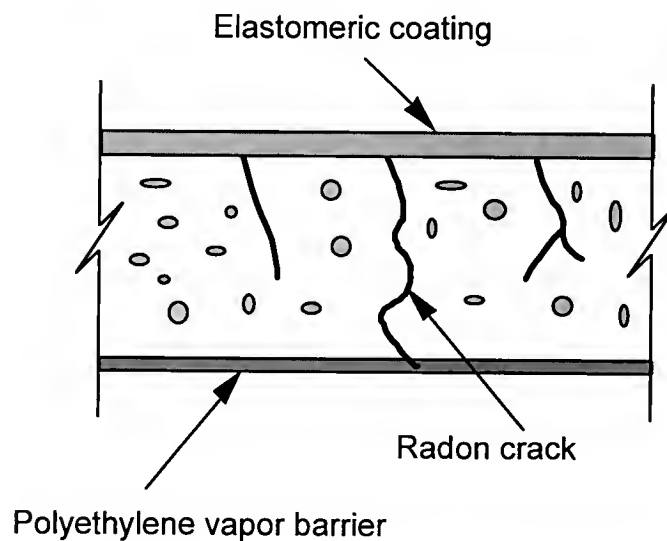



Crack.fig.1b

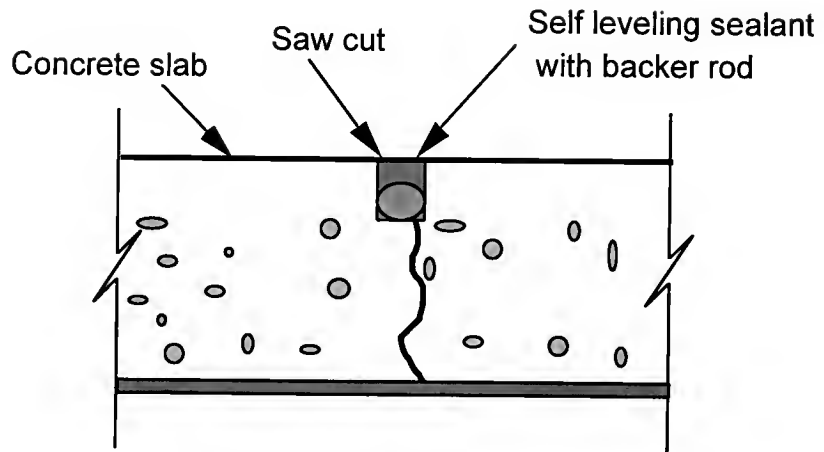

Crack.fig.1c

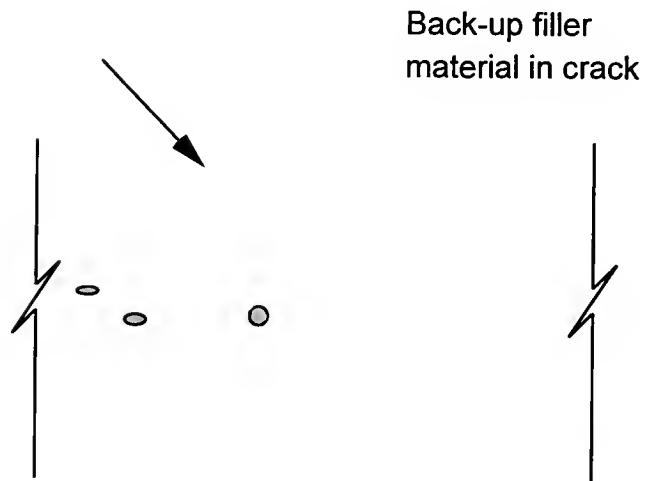

Crack Treatment Knowledge Base

Depending on slab type, foundation structure and wall type, the knowledge base advises the method to crack problems.

MacSMARTS Knowledge Base: perimeter.rule

FACTS:

1 TRUE

RULES:

- 1 Construction detail: (fig.1); Materials used: polyethylene vapor barrier to exterior.  
IF YES: Is the slab type monolithic?  
IF YES: Is the house built slab-on-grade?
- 2 Construction detail: (fig.2); Materials used: polyethylene vapor barrier to exterior.  
IF YES: Is the slab type monolithic?  
IF NO: Is the house built slab-on-grade?  
IF YES: Is house built of stem wall?
- 3 Construction detail: (fig.3); Materials used: polyethylene vapor barrier to exterior.  
IF YES: Is the slab type monolithic?  
YES: Is the house built with increasingslab  
IF NO: Is the house built slab-on-grade?  
IF width at the end of the wall?

4 Construction detail: (fig.4); Materials used:  
polyurethane or polysulfide sealants.

IF NO: Is the slab type monolithic?

IF YES: Is the house built with floating slab?

5 Construction detail: (fig.5); Materials used:  
polyurethane sealants & waterproofing membranes or  
polysulfide sealants.

IF NO: Is the slab type monolithic?

IF NO: Is the house built with floating slab?

IF YES: Is the house built with fixed slab?

ADVICE:

1 Construction detail: (fig.1); Materials used:  
polyethylene vapor barrier to exterior.

PRIMARY LINK:perimeter.fig.1

2 Construction detail: (fig.2); Materials used:  
polyethylene vapor barrier to exterior.

PRIMARY LINK:perimeter.fig.2p

3 Construction detail: (fig.3); Materials used:  
polyethylene vapor barrier to exterior.

PRIMARY LINK:perimeter.fig.3.incrp

4 Construction detail: (fig.4); Materials used:  
polyurethane or polysulfide sealants.

PRIMARY LINK:perimeter.fig.4p

5 Construction detail: (fig.5); Materials used:  
polyurethane sealants & waterproofing membranes or

polysulfide sealants.  
PRIMARY LINK:perimeter.fig.5p

The following drawings are the advice of the crack  
treatment knowledge base.

Perimeter.fig.1p { fig.1p to fig.5p were modify from [ACRES 1990]}

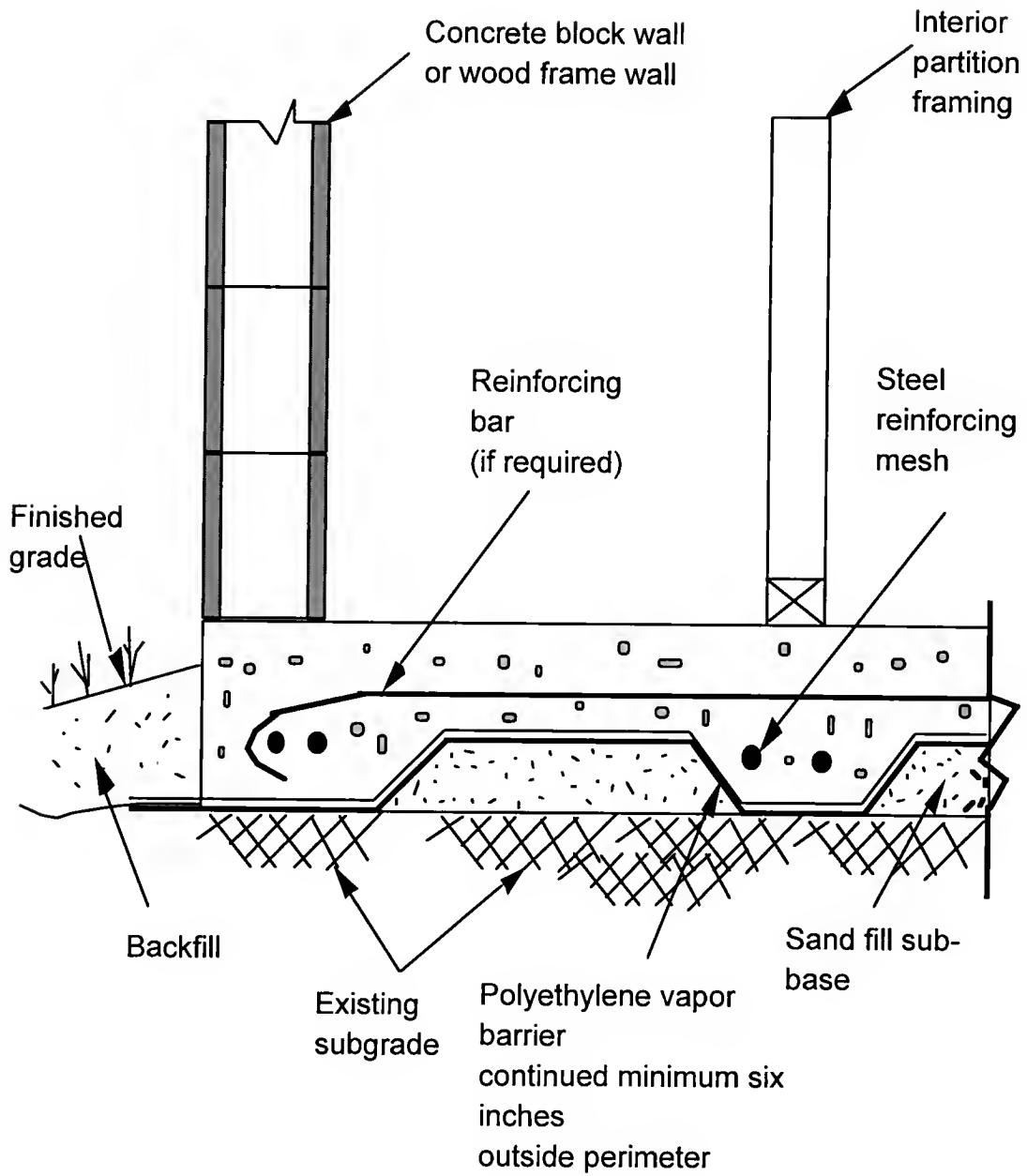

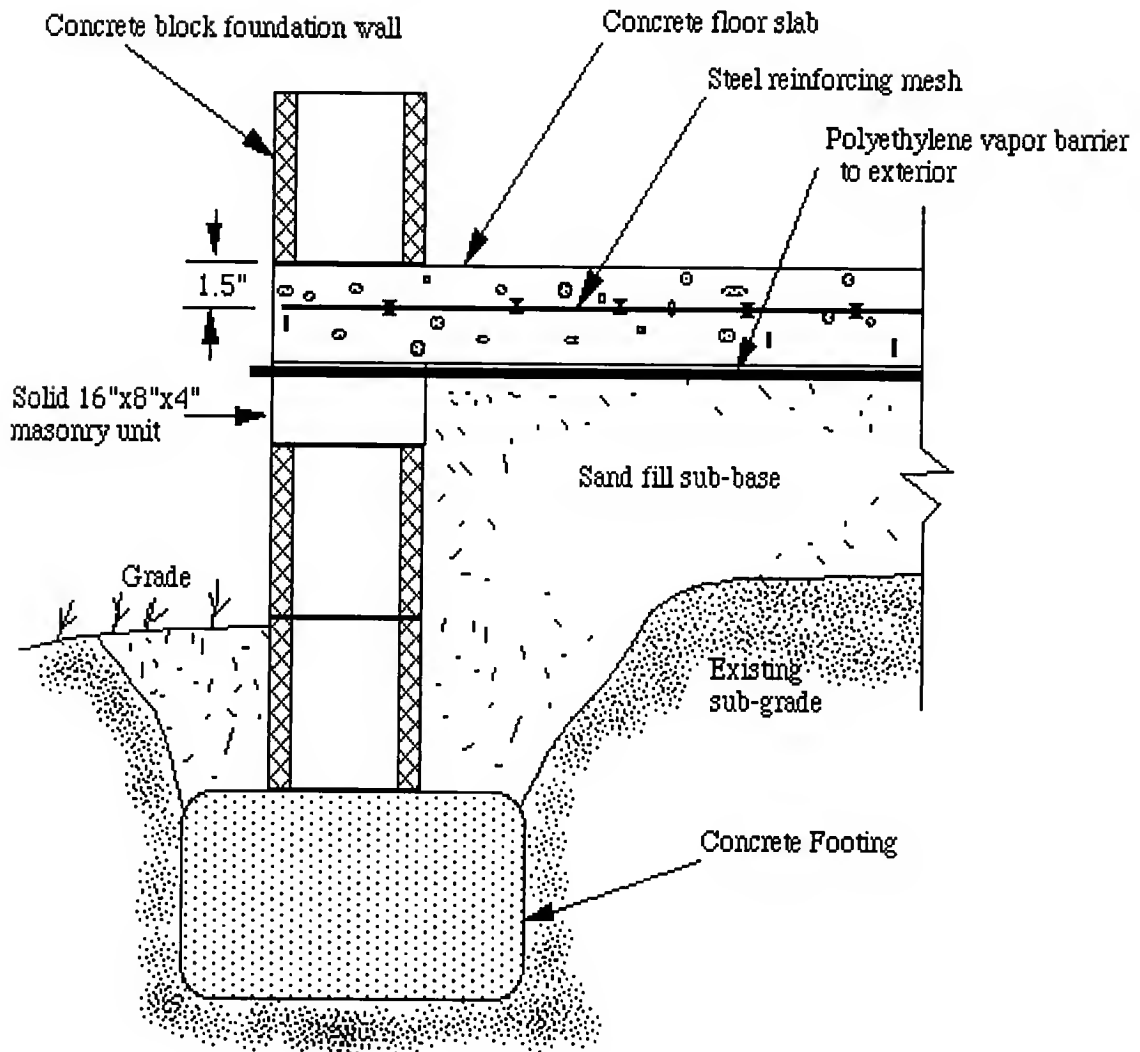
Perimeter.fig.2p

Perimeter.fig.3p

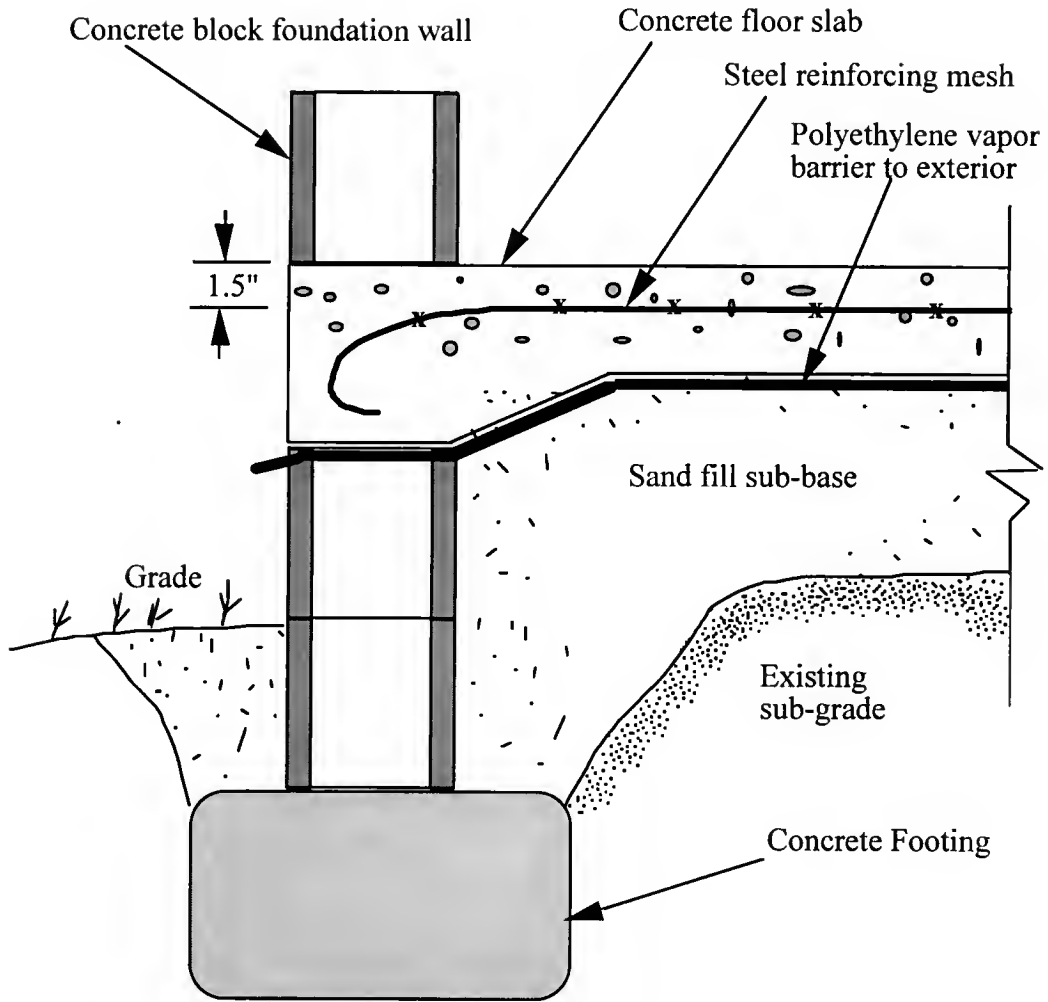

Perimeter.fig.4p

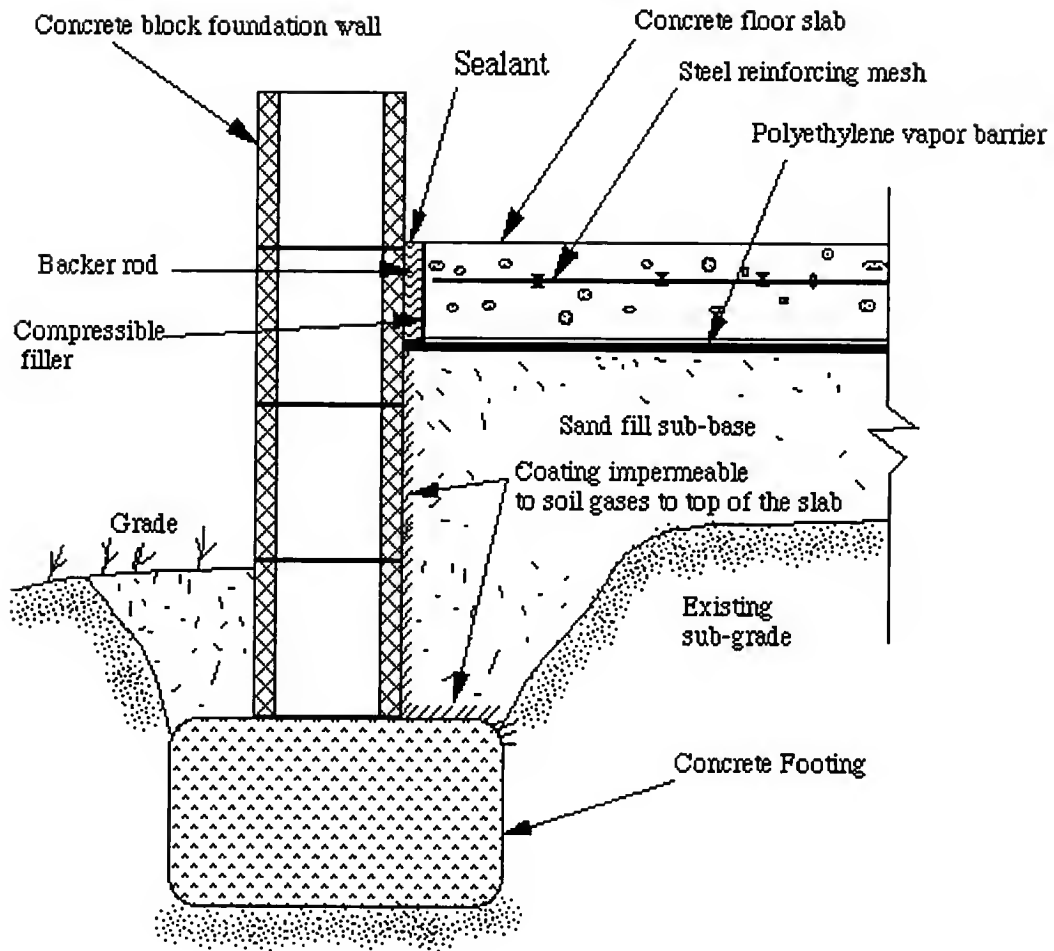



Perimeter.fig.5p

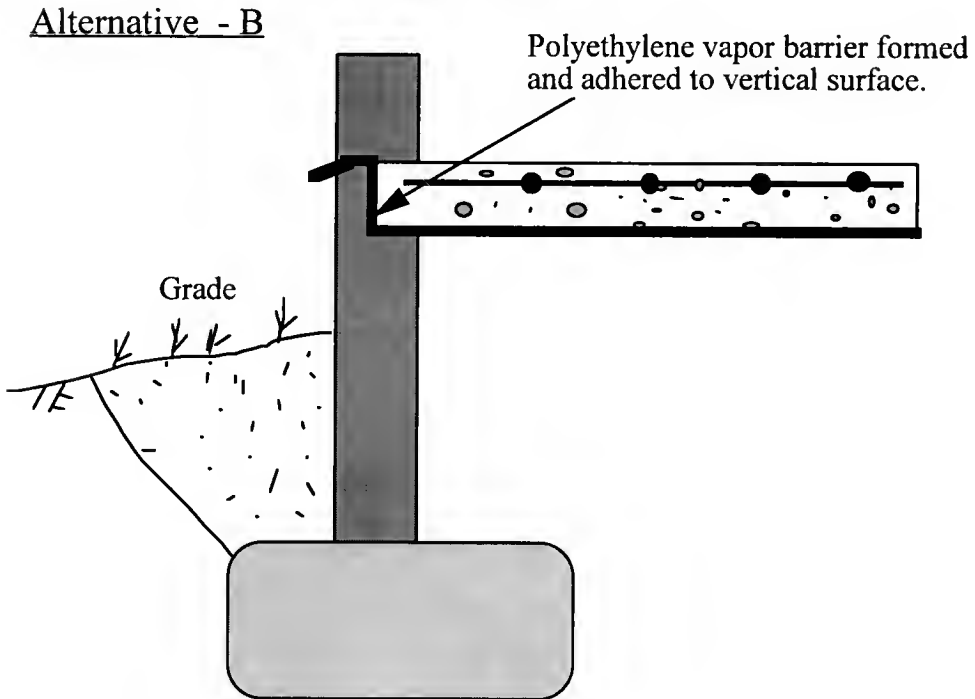
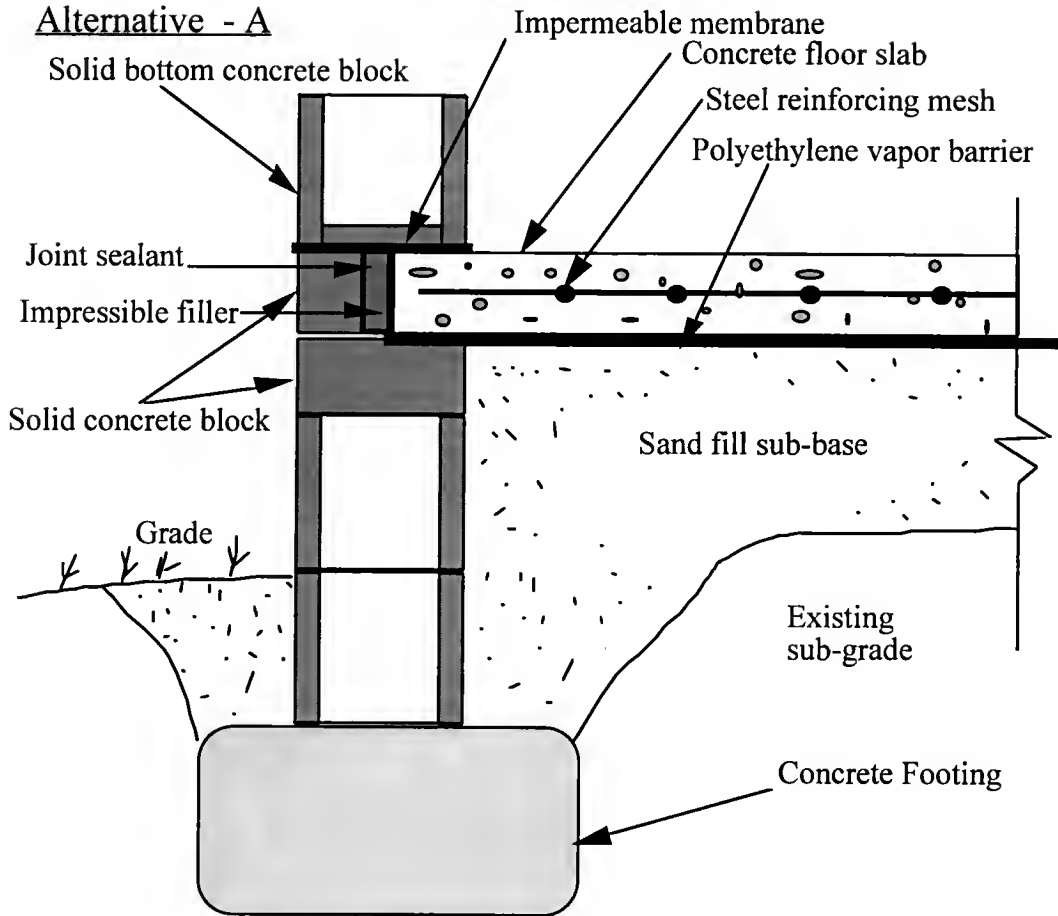

Indoor Radon Prediction Knowledge Base

This file is the sample-based knowledge base. It uses decision table which simplifies the input and output into a table format.

1) MacSMARTS Knowledge Base: Indoor.Radon.predif

DECISION TABLE KNOWLEDGE BASE

FACTS:

1 TRUE

RULES:

1 Indoor radon

ADVICE:

1 Indoor radon

PRIMARY LINK:indoor.prediction.pict

2) MacSMARTS Knowledge Base: crack.diagnosis.user

Based on the curing time, construction joint installation, construction joint spacing, site temperature and construction quality to predict potential cracking.

FACTS:

1 TRUE

RULES:

- 1       The predicted concrete floor has:"Minor Cracking"  
IF YES: period>=st.time  
IF YES: Were construction joints installed?  
          PRIMARY LINK:summit-oaks.pict  
IF YES: joint\_spacing<=joints
  
- 2       The predicted concrete floor has:"Moderate Cracking"  
  
IF NO: period>=st.time  
IF YES: Were construction joints installed?  
          PRIMARY LINK:summit-oaks.pict  
IF YES: joint\_spacing<=joints
  
- 3       The predicted concrete floor has:"Moderate Cracking"  
  
IF NO: period>=st.time  
IF YES: Were construction joints installed?  
          PRIMARY LINK:summit-oaks.pict  
IF NO: joint\_spacing<=joints  
IF YES: Temperature<=St.temp
  
- 4       The predicted concrete floor has:"Moderate Cracking"  
  
IF YES: period>=st.time  
IF NO: Were construction joints installed?  
          PRIMARY LINK:summit-oaks.pict
  
- 5       The predicted concrete floor has:"Serious Cracking"  
  
IF NO: period>=st.time  
IF YES: Were construction joints installed?

PRIMARY LINK:summit-oaks.pict

IF NO: joint\_spacing<=joints

IF NO: Temperature<=St.temp

6 The predicted concrete floor has:"Moderate Cracking"

IF NO: period>=st.time

IF NO: Were construction joints installed?

PRIMARY LINK:summit-oaks.pict

IF YES: Temperature<=St.temp

IF YES: Was the concrete pouring in good quality?

7 The predicted concrete floor has:"Serious Cracking"

IF NO: period>=st.time

IF YES: Were construction joints installed?

PRIMARY LINK:summit-oaks.pict

IF NO: joint\_spacing<=joints

IF YES: Temperature<=St.temp

IF NO: Was the concrete pouring in good standard?

8 The predicted concrete floor has:"Serious Cracking"

IF NO: period>=st.time

IF NO: Were construction joints installed?

IF NO: Temperature<=St.temp

IF NO: Was the concrete pouring in good quality?

9 The predicted concrete floor has:"Moderate Cracking"

IF NO: period >=st.time

IF NO: Were construction joints installed?

PRIMARY LINK:summit-oaks.pict

IF NO: Temperature>=St.temp

IF YES: Was the concrete pouring in good quality?

10 The predicted concrete floor has : "Serious Cracking"

IF NO: period<= st.time

IF YES: Were construction joints installed?

IF NO: joint\_spacing<=joints

IF NO: Temperature>=St.temp

ADVICE:

1 The predicted concrete floor has: "Minor Cracking"

2 The predicted concrete floor has: "Moderate Cracking"

3 The predicted concrete floor has: "Moderate Cracking"

4 The predicted concrete floor has: "Moderate Cracking"

5 The predicted concrete floor has: "Serious Cracking"

6 The predicted concrete floor has: "Moderate Cracking"

7 The predicted concrete floor has: "Serious Cracking"

8 The predicted concrete floor has: "Serious Cracking"

9 The predicted concrete floor has: "Moderate Cracking"

10 The predicted concrete floor has: "Serious Cracking"

## LIST OF REFERENCES

- ACRES, "Radon Diffusion through Concrete," Atomic Energy Control Board, Elliot Lake Technical Note No.2, Dilworth, Second, Meagher and Associates Limited, ACRES Consulting Services Limited, DSMA Report No.1012/975; (1978)
- ACRES, "Radon Entry Through Cracks in Slab-On-Grade," Final Report, Vol.II, Sealants for Cracks and Openings in Concrete, ACRES International Corporation, Prepared for Florida Department of Community Affairs, Tallahassee, Florida; (1990)
- Al-Ahmady, K.K., "Measurements and Theoretical Modeling of A Naturally Occurring  $^{222}\text{Rn}$  Entry Cycle For Structures Built Over Low Permeability Soils," Master of Engineering Thesis, University of Florida, Gainesville, Florida; (1992)
- Al-Ahmady, K.K., "Radon Laboratory," Class Lecture, University of Florida, Gainesville, Florida; (1994)
- Al-Ahmady, K.K. and Hintenlang, D.E., "Assessment of Temperature-Driven Pressure Differences With Regard to Radon Entry and Indoor Radon Concentration," Proceedings of the 1994 International Radon Symposium, Atlantic City, New Jersey, p.III6.1-III6.11; (1994a)
- Al-Ahmady, K.K. and Hintenlang, D.E., "Modeling of Sub-Slab Depressurization Radon Mitigation Systems for Large Structures," Proceedings of the 1994 International Radon Symposium, Atlantic City, New Jersey, p.VP1.1-VP1.9; (1994b)
- Beerel, A.C., "Expert Systems, Strategic Implications and Applications," Ellis Horwood Limited, New York, p.32; (1987)

- Bodansky, D., Robkin, M. and Stadler, D.R., "Indoor Radon and its Hazards," University of Washington Press, Seattle, Washington, p.12; (1987)
- Bryant, N.W., "Managing Expert Systems," John Wiley & Sons Ltd., New York, p.13-14; (1988)
- Clarkin, M. and Brennan, T., "Radon-resistant Construction Techniques for New Residential Construction," U.S. Environmental Protection Agency, Research Triangle Park, North Carolina, EPA/625/2-91/032; (1991)
- Department of Community Affairs (DCA), "Draft Florida Standard for Radon-Resistant Building Construction," Tallahassee, Florida; (1991)
- Department of Community Affairs (DCA), "Guidelines for the Construction of Radon Resistant Houses in Florida: Construction Slab Construction," State of Florida, Tallahassee, Florida; (1993)
- Department of Community Affairs (DCA), "Radon Protection Categories," Prepared by GeoPlan Center, University of Florida, Prepared for State of Florida, Tallahassee, Florida; (1994)
- Department of Health and Rehabilitative Services (HRS), "Radon Reduction Methods: A Homeowners' Guide," Tallahassee, Florida, Second edition; (1988)
- Dym, C.L. and Levitt, R.E., "Knowledge Based Systems in Engineering," McGraw-Hill, Inc., New York; (1992)
- Eatough, J.P. and Henshaw, D.L., "Radon Exposure and Myeloid Leukaemia," International Journal of Epidemiology, Vol.23, No.2, p.430-431, April; (1994)
- Espenshade, G.H., "Geologic Features of Areas of Abnormal Radioactivity South of Ocala, Marion County, Florida," U.S. Geologic Survey Bulletin 118, p.115; (1985)
- Fleischer, R.L. and Turner, L.G., "Indoor Radon Measurement in the New York Capital District," Health Physics, Vol.46, No.5, p.999-1011; (1984)

- Garbesi, K. and Sextro, R.G., " Modeling and Field Evidence of Pressure-Driven Entry of Soil Gas into a House through Permeable Below-Grade Walls," Environmental Science Technology, Vol.23, No.12, p.1481-1486; (1989)
- Goodman, D., "The Complete Hypercard 2.0, Handbook", third edition, Random House Inc., New York; (1994)
- Gundersen, L.C.S., "The Correlation between Bedrock Geology and Indoor Radon Where it Works and Where it Doesn't: Some Examples from the Eastern United States," The 1993 Internal Radon Conference; (1993)
- Gundersen, L.C.S., Schumann, R.R. and White, S.W., "The USGS/EPA Radon Potential Assessments: An Introduction", Environmental Protection Agency, EPA's Map of Radon Zones, Florida, 402-R-93-029, p.II-1 to II-19; (1993)
- Harper, J.P., Joyner, P.A., Nagda, N.L. and Dudney, C.S., "Radon Entry and Control: Influence of Building Factors," Energy and Technology, Vol.15, p.414; (1988)
- Hintenlang, D.E. and Al-Ahmady, K.K., "Pressure Differentials for Radon Entry Coupled to Periodic Atmospheric Pressure Variations," Indoor Air, Vol.2, p.208-215; (1992)
- Hintenlang, D.E., Shanker, A.J., Najafi, F.T. and Roessler, C.E., "Evaluation of Building Design, Construction and Performance for the Control of Radon in Florida Houses: Evaluation of Radon Resistant Construction Techniques in Eight New Houses," Final Report, number 93RD-66-13-00-22-009. Prepared for State of Florida, Department of Community Affairs, Tallahassee, Florida, September; (1994a)
- Hintenlang, D.E., Shanker, A.J., Najafi, F.T. and Roessler, C.E., "Evaluation of Building Design, Construction and Performance for the Control of Radon in Florida Houses: Long Term Monitoring, Crack Study, Soil Analysis, Radon Entry Study," Final Report, contract number 93RD-66-13-00-22-008. Prepared for State of Florida, Department of Community Affairs, Tallahassee, Florida, September; (1994b)



- Hoddinott, K.B. and Lamb, R.O., "Physical-Chemical Aspects of Soil and Related Materials," ASTM, Philadelphia, Pennsylvania, p.55; (1990)
- Johnson, R.H., Bernhardt, D.E., Nelson N.S. and Calley, H.W., Jr., "Assessment of Potential Radiological Health Effects from Radon in Natural Gas," U.S. Environmental Protection Agency, Office of Radiation Programs, Washington, D.C.; (1973)
- Landman, K.A., "Diffusion of Radon through Cracks in a Concrete Slab," Health Physics, Vol.30, p65; (1982)
- Lao, K.Q., "Controlling Indoor Radon: Measurement, Mitigation and Preventing," Van Nostrand Reinhold, New York; (1990)
- Littell, R.C., Freund, R.J. and Spector, P.C., "SAS Series in Statistical Applications," SAS Institute Inc., Cary, North Carolina; (1993)
- Loureiro, C.O., Abriola, L.M., Martin, J.E. and Sextro, R.G., "Three-Dimensional Simulation of Radon Transport into Houses with Basements under Constant Negative Pressure," Environmental Science and Technology, Vol.24, p.1338-1384; (1990)
- Lowry, J.D. and Lowry, S., "Techniques and Economic of Radon Removal from Water Supplies," Radon and Environment, p.97-103; (1988)
- MacSmarts Corporation, "MacSmarts™ Professional", User's Menu Vers.5.0, Cognition Technology, Cambridge, Massachusetts; (1994)
- Means, "Means Building Construction Cost Data," R.S. Means Company, Inc., 51st Annual Edition, Kingston, Massachusetts; (1993)
- Morawska, L., Philips, C.R., "Determination of Radon Surface Emanation Rate from Laboratory Emanation Data," The Science of the Total Environment, Vol.106, p.235-262; (1991)

- Mose, D.G., Mushrush, G.W. and Chrosniak, C.E., "Soil Radon, Permeability, and Indoor Radon Prediction," Environmental Geology and Water Sciences, Vol.10, No.2, p.91-91; (1992)
- Najafi, F.T., Shanker, A., Rossler, C. E., Hintenlang, D.E., and Tyson, J., "New House Evaluation of Potential Building Design and Construction for the Control of Radon in Marion and Alachua Counties, Florida," Final Report, Department of Community Affairs, Tallahassee, Florida; (1993)
- Nazaroff, W.W., "Radon Transport From Soil to Air," Reviews of Geophysics, Vol.30, No.2, p.137-160; (1992)
- Nazaroff, W.W., Lewis, S.R., Doyle, S.M., Moed, B.A. and Nero, A.V., "Experiments on Pollutant Transport from Soil into Residential Basements by Pressure-Driven Airflow," Environmental Science Technology, Vol.21, p.459-466; (1987)
- Nazaroff, W.W., Moed, B.A. and Sextro, R.G., "Soil as a Source of Indoor Radon: Generation, Migration, and Entry," In: Nazaroff, W.W., Nero, A.V., eds, Radon and its Decay Products in Indoor Air, New York, John Wiley and Sons; (1988)
- Nero, A.V. and Nazaroff, W.W., "Characterising the Source of Radon Indoors," Radiation Protection Dosimetry, Vol.7, p.23-29; (1984)
- Ott, L., "An Introduction to Statistical Methods and Data Analysis," Third Edition, PWS-Kent Publication Company, Boston, Massachusetts; (1988)
- Otton, J.K., "Preliminary Geologic Radon Potential Assessment of Florida," U.S. Geological Survey, EPA's Map of Radon Zones, Florida, p.IV-1-IV-25; (1993)
- Qu, G., "A Method to Determine Radon Entry Rate and Ventilation Rate by Measuring Radon and Its Daughter Equilibrium Ratio in A House," Master of Science Thesis, University of Florida, Gainesville, Florida; (1993)

- Revzan, K.L. and Fisk, W.J., "Modeling Radon Entry into Houses with Basements: The Influence of Structural Factors," *Indoor Air*, Vol.2, p.40-48; (1992)
- Roessler, C.E., Roessler, G.S. and Bolch, W.E., "Indoor Radon Progeny Exposure in the Florida Phosphate Mining Region: A Review," *Health Physics*, Vol.45, No.2, p.389-396; (1983)
- Rogers, V.C., Nielson, K.K. and Merrell, G.B., "Radon Generation, Adsorption, Absorption, and Transport in Porous Media," Rep., DOE/ER/60664-1, U.S., Department of Energy, Washington, D.C.; (1989)
- Rogers, V.C. and Nielson, K.K., "Benchmark and Application of the RAETRAD Model," In: *The 1990 International Symposium on Radon and Radon Reduction Technology*, Vol. 3, EPA/600/9-90/005C, U.S. Environmental Protection Agency, Washington, D.C.; (1990)
- Rogers, V.C. and Nielson, K.K., "Correlation of Florida Soil-Gas Permeability with Grain Size, Moisture, and Porosity," *Environmental Protection Agency, Project Summary*, p.2-3; (1991a)
- Rogers, V.C. and Nielson, K.K., "Recommended Foundation Fill Materials Construction Standard of the Florida Radon Research Program," *Environmental Protection Agency*, EPA-600/8-91-206, p.2-3; (1991b)
- Rogers, V.C. and Nielson, K.K. "Data and Models for Radon Transport through Concrete," In: *The international Symposium on Radon and Radon Reduction Technology*, Vol. 2, Minneapolis, Minnesota; (1992)
- Scott, C.R., "Soil Mechanics and Foundations," *Maclaren and Sons*, London, England, p.63-64; (1969)
- Shanker, A.J., "Cost Estimation of Suction Pit and Enkavent Mat Methods," *School of Building Construction*, University of Florida, Gainesville, Florida; (1993)
- Sweeney, J.W. and Windham, S.R., "Florida: the New Uranium Producer," *Florida Geologic Survey Special Publication*, No.22, p.13; (1979)

- Tanner, A.B., "The Role of Diffusion in Radon Entry Into Houses," In: The 1990, International Symposium on Radon Reduction Technology, Vol.3, EPA/600/9-90/005C, U.S. Environmental Protection Agency, Washington, D.C; (1990)
- Todd, D.K., "Groundwater Hydrology," second edition, University of California, Berkeley and David Keith Todd, Consulting Engineers, Inc., Berkeley, California ; (1980)
- U.S. Environmental Protection Agency (EPA), "A Citizen's Guide to Radon: What it is and What to do about it?" Office of Air and Radiation, OPA-86-004, Washington, D.C.; (1986)
- U.S. Environmental Protection Agency (EPA), "Radon-resistant Construction Techniques for New Residential Construction," Office of Research and Development, Technical Guidance, EPA/625/2-91/032, Washington, D.C., p.9-37; (1991)
- U.S. Environmental Protection Agency (EPA), "Radon Mitigation Research Update," Office of Research and Development, Washington, D.C., June; (1992)
- U.S. Environmental Protection Agency (EPA), "Electrical Induced Barriers to Soil-Gas Movement," Radon Mitigation Research Update, Office of Research and Development, EPA/600/N-94/011, Washington, D.C., p.2-6; (1994)
- U.S. General Accounting Office (GAO), "Limited Federal Response to Reduce Radon Contamination in Housing," Testimony, GAO/T-RCED-88-43, Washington, D.C., May; (1988)
- U.S. House of Representatives (HR), "Federal Efforts to Promote Radon Testing," Hearing before the Subcommittee on Natural Resources, Agriculture Research and Environment of the Committee on Science, Space, and Technology, Washington, D.C., May 16; (1990)

- U.S. House of Representatives (HR), "Radon Awareness and Disclosure," Joint Hearing, before the Subcommittee on Health and the Environment and the Subcommittee on Transportation and Hazardous Materials of the Committee on Energy and Commerce, 103 Congress, 1st section H.R. 2448, U.S. Governmental Printing Office, Washington, D.C., July 14; (1993)
- U.S. House of Representatives (HR), "Radon Awareness and Disclosure Act of 1994," 103d Congress, 2d session, Report 103-574, p.12-14, June 30; (1994)
- Ward, D.C., Borak T.B. and Gadd M.S., "Characterization of  $^{222}\text{Rn}$  Entry into a Basement Structure Surrounded by Low Permeability Soil," Health Physics, Vol.65, No.1, p.1-11; (1993)
- Wu, x. and Medora, R.P., "Use of Radium Containing Materials for Construction," Natural Radiation and Technologically Enhanced Natural Radiation in Florida, Radiation Daytona Beach, Florida, May 6-8; (1987)
- Yegingli, Z., "Review of Identifying Rare Circumstances in Radon Problem: High Soil Permeability and Radium Content," Science International (Lahore), Vol.3, No.3, p.179-182; (1991)

## BIOGRAPHICAL SKETCH

Mr. Li finished his undergraduate study in Taiwan at the Taipei Institute of Technology in 1986. He served the mandatory military duty in the marine corps from 1986 to 1988. He worked as a civil engineer in the City of Taipei from mid 1988 to early 1989, where he participated in structural design and cost estimation.

Mr. Li came to the United States to pursue graduate study in January 1989. From 1989 to 1990, he attended the University of Delaware, receiving his Master of Engineering in Structures.

From January 1991 through August 1992, he attended the University of Maryland and received his Master of Science in Construction Engineering and Management. Upon finishing school in Maryland, he headed to the sunshine of Florida. He began his Ph.D. study at the University of Florida and has been enjoying the university and the beautiful Tree City of the South, Gainesville.

He is a student member of the American Society of Civil Engineers and a member of Tau Beta Pi.

I certify that I have read this study and that in my opinion it conforms to acceptable standards of scholarly presentation and is fully adequate, in scope and quality, as a dissertation for the degree of Doctor of Philosophy.

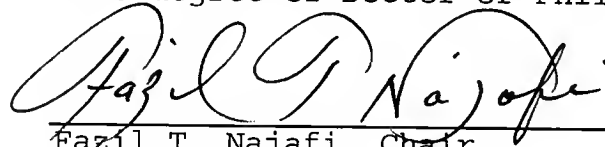

---

Fazil T. Najafi, Chair

Associate Professor of Civil Engineering

I certify that I have read this study and that in my opinion it conforms to acceptable standards of scholarly presentation and is fully adequate, in scope and quality, as a dissertation for the degree of Doctor of Philosophy.

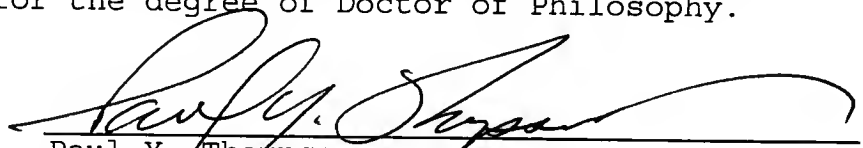

---

Paul Y. Thompson

Professor of Civil Engineering

I certify that I have read this study and that in my opinion it conforms to acceptable standards of scholarly presentation and is fully adequate, in scope and quality, as a dissertation for the degree of Doctor of Philosophy.

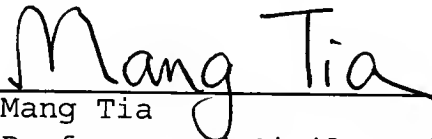

---

Mang Tia

Professor of Civil Engineering

I certify that I have read this study and that in my opinion it conforms to acceptable standards of scholarly presentation and is fully adequate, in scope and quality, as a dissertation for the degree of Doctor of Philosophy.

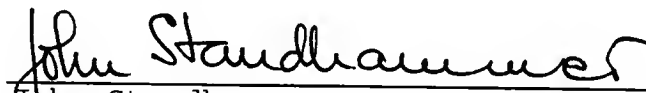

---

John Staudhammer

Professor of Electrical Engineering

I certify that I have read this study and that in my opinion it conforms to acceptable standards of scholarly presentation and is fully adequate, in scope and quality, as a dissertation for the degree of Doctor of Philosophy.

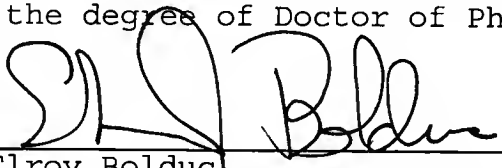
  
\_\_\_\_\_  
Elroy Bolduc  
Professor of Instruction and Curriculum

This dissertation was submitted to the Graduate Faculty of the College of Engineering and to the Graduate School and was accepted as partial fulfillment of the requirements for the degree of Doctor of Philosophy.

May, 1995

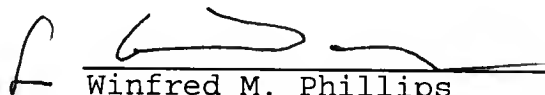
  
\_\_\_\_\_  
Winfred M. Phillips  
Dean, College of Engineering

\_\_\_\_\_  
Karen A. Holbrook  
Dean, Graduate School



LD  
1780  
1995  
.L693

UNIVERSITY OF FLORIDA



3 1262 08556 8185